



SNOW PLOW ASSEMBLIES

JD 6X30

Current as of 1/17/2014



**PARTS LISTING WITH
MOUNTING AND OPERATING
INSTRUCTIONS**

Tiger Corporation
3301 N. Louise Ave.
Sioux Falls, SD 57107
1-800-843-6849
1-605-336-7900
www.tiger-mowers.com

06011008

TO THE OWNER / OPERATOR / DEALER

All implements with moving parts are potentially hazardous. There is no substitute for a cautious, safe-minded operator who recognizes the potential hazards and follows reasonable safety practices. The manufacturer has designed this implement to be used with all its safety equipment properly attached to minimize the chance of accidents.

BEFORE YOU START!! Read the safety messages on the implement and shown in this manual. Observe the rules of safety and use common sense!

READ AND UNDERSTAND THIS MANUAL! Non-English speaking operators will need to GET THE MANUAL TRANSLATED as needed!



DANGER

FAILING TO FOLLOW SAFETY MESSAGES AND OPERATING INSTRUCTIONS CAN CAUSE SERIOUS BODILY INJURY OR EVEN DEATH TO OPERATOR AND OTHERS IN THE AREA.



1. Study and understand Operator's Manuals, Safety Decals, and Instructional Decals for tractor and implement to prevent misuse, abuse, and accidents. Practice before operating in a confined area or near passersby.

● Learn how to stop engine suddenly in an emergency. Be alert for passersby and especially children

2. Allow no children on or near folding mower or tractor. Allow no riders on tractor or implement. Falling off may cause serious injury or death from being run over by tractor or mower or contact with rotating blades.

3. Operate only with tractor having Roll-Over Protective Structure (ROPS) and with seat belt securely fastened to prevent injury and possible death from falling off or tractor overturn.

● Personal Protective Equipment such as Hard Hat, Safety Glasses, Safety Shoes, & Ear Plugs are recommended.

4. Block up or support raised machine and all lifted components securely before putting hands or feet under or working underneath any lifted component to prevent crushing injury or death from sudden dropping or inadvertent operation of controls. Make certain area is clear before lowering or folding

5. Before transporting, put Lift Lever in detent or full-lift position. Install Transport Safety Devices securely on folding mowers. Put Booms securely in Transport Rest.

● Folding and Boom Mowers have raised center of gravity. Slow down when turning and on hillsides.

6. Make certain that SMV sign, warning lights, and reflectors are clearly visible. Follow local traffic codes.

7. Never operate with Cutting Head or Folding Section raised if passersby, bystanders, or traffic are in the area to reduce possibility of injury or death from objects thrown by Blades under Guards or mower structure.

8. Before dismounting, secure implement in transport position or lower to ground.

● Put tractor in park or set brake, disengage PTO, stop engine, remove key, and wait until noise of rotation has ceased to prevent crushing by entanglement in rotating parts which could cause injury or death.

● Never mount or dismount a moving vehicle. Crushing from runover may cause serious injury or death.



02967827

Warranty Information: Read and understand the complete Warranty Statement found in this manual. Fill out the Warranty Registration form in full and return it within 90 days. Make certain the Serial Number of the machine is recorded on the Warranty Card, and form that you retain.

FORWARD

This manual contains information about many features of the Tiger mowing and roadside maintenance equipment. Some of these include: Safety precautions, Assembly instructions, Operations, Maintenance and Parts. This manual will also assist you in the proper break-in, daily care, and troubleshooting of your new mower.

We recommend that you read carefully the entire manual before operating the unit. Also, time spent in becoming fully acquainted with its performance features, adjustments, and maintenance schedules will be repaid in a long and satisfactory life of the equipment.

Troubleshooting - Please, before you call, help us to help you!

Please look at the equipment to observe what is happening, then:

- Classify the problem
 - Hydraulic, electrical or mechanical - Read the trouble shooting section
 - Tractor or Truck chassis - Contact vehicle dealer

- If unable to correct the problem yourself, contact your local Tiger Dealer after gathering:
 - Machine model _____
 - Serial number _____
 - Dealer name _____
 - Detailed information about the problem including results of troubleshooting

Attention Owner / Operator / Dealer: It is your obligation to read, and understand, the warranty information section located at the back of this manual denoting that the purchaser understands the safety issues relating to this machine and has received and will read a copy of this manual.

If at any time, you have a service problem with your Tiger mower, Contact your local dealer for service and parts needed.

MANUFACTURED BY:

Tiger Corporation

3301 N. Louise Ave.

Sioux Falls, SD 57107

1-800-843-6849

1-605-336-7900

www.tiger-mowers.com

DISTRIBUTED BY:

1- _____ - _____ - _____

1- _____ - _____ - _____

TABLE OF CONTENTS

SAFETY SECTION_____	1
ASSEMBLY / MOUNTING SECTION_____	2
OPERATION SECTION_____	3
MAINTENANCE SECTION_____	4
PARTS SECTION_____	5
WARRANTY INFORMATION_____	6



1012

This symbol means:

CAUTION – YOUR SAFETY IS AT RISK!

When you see this symbol, read and follow the associated instructions carefully or personal injury or damage may result.

Tiger is a registered trademark.



SAFETY SECTION

Safety Section 1-1

SAFETY

GENERAL SAFETY INSTRUCTIONS AND PRACTICES

A careful operator is the best operator. Safety is of primary importance to the manufacturer and should be to the owner/operator. Most accidents can be avoided by being aware of your equipment, your surroundings, and observing certain precautions. The first section of this manual includes a list of Safety Messages that, if followed, will help protect the operator and bystanders from injury or death. Read and understand these Safety Messages before assembling, operating or servicing this Implement. This equipment should only be operated by those persons who have read the manual, who are responsible and trained, and who know how to do so responsibly.



The Safety Alert Symbol combined with a Signal Word, as seen below, is used throughout this manual and on decals which are attached to the equipment. The Safety Alert Symbol means: "ATTENTION! BECOME ALERT! YOUR SAFETY IS INVOLVED!" The Symbol and Signal Word are intended to warn the owner/operator of impending hazards and the degree of possible injury faced when operating this equipment.

Practice all usual and customary safe working precautions and above all---remember safety is up to YOU. Only YOU can prevent serious injury or death from unsafe practices.



Indicates an imminently hazardous situation that, if not avoided, WILL result in DEATH OR VERY SERIOUS INJURY.



Indicates an imminently hazardous situation that, if not avoided, COULD result in DEATH OR SERIOUS INJURY.



Indicates an imminently hazardous situation that, if not avoided, MAY result in MINOR INJURY.



Identifies special instructions or procedures that, if not strictly observed, could result in damage to, or destruction of the machine, attachments or the environment.

NOTE: *Identifies points of particular interest for more efficient and convenient operation or repair.* (SG-1)

READ, UNDERSTAND, and FOLLOW the following Safety Messages. Serious injury or death may occur unless care is taken to follow the warnings and instructions stated in the Safety Messages. Always use good common sense to avoid hazards. (SG-2)



SAFETY

WARNING

Repeated or substantial breathing of hazardous dusts, including crystalline silica, could cause fatal or serious respiratory disease including silicosis. Concrete, masonry, many types of rock, and various other materials contain silica sand. California lists respirable crystalline silica as a substance known to cause cancer. Operation of this equipment under certain conditions may generate airborne dust particles that could contain crystalline silica. In those conditions, personal protective equipment including an appropriate respirator must be used. If excessive dust is generated, a dust collection or suppression system should also be used during operation. (SG-41)

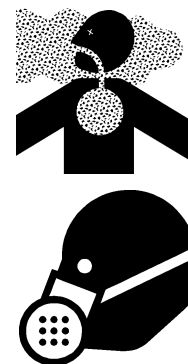

PELIGRO

Si no lee ingles, pida ayuda a alguien que si lo lea para que le traduzca las medidas de seguridad. (SG-3)

¡ LEA EL INSTRUCTIVO!



DANGER

Never operate the Snow Plow until you have read and completely understand this Manual, the Truck or Power units Operator's Manual, and each of the Safety Messages found in these Manuals and those affixed to the Snow Plow, Truck, or Power units and its components. Learn how to stop the power unit engine suddenly in an emergency. Never allow inexperienced or untrained personnel to operate the Truck or Power unit and Snow Plow without supervision. Make sure the operator has fully read and understood the manuals prior to operation. (SPNG-4)

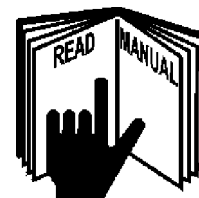

In addition to the design and configuration of this Snow Plow, including Safety Signs and Safety Equipment, hazard control and accident prevention are dependent upon the awareness, concern, prudence, and proper training of personnel involved in the operation, transport, maintenance, and storage of the machine. Refer also to Safety Messages and operation instruction in each of the appropriate sections of the Truck or Power unit Manuals. Pay close attention to the Safety Signs affixed to the Snow Plow. (SNPG-5)

PARTS INFORMATION

HENKE Snow Plows use balanced and matched system components for plows, carriers, and other components. These parts are made and tested to HENKE specifications. Non-genuine or "will fit" parts do not consistently meet these specifications. The use of non-genuine or "will fit" parts may reduce Snow Plow performance, void HENKE warranties, and present a safety hazard. Use genuine HENKE parts for economy and safety. (SNPG-6)

SEE YOUR HENKE DEALER

WARNING

Always maintain the safety signs in good readable condition. If the safety signs are missing, damaged, or unreadable, obtain and install replacement safety signs immediately. (SG-5)

SAFETY

SAFETY



All Safety Shields, Guards and other Protective Safety devices should be used and maintained in good working condition. All safety devices should be inspected carefully at least daily for missing or broken components. **NEVER REMOVE PROTECTIVE SHIELDS AND GUARDS! NEVER MODIFY OR CUT PROTECTIVE SHIELDS OR GUARDS!** When shields or guards are removed to access areas for maintenance, they must be replaced and be in good condition before operating. Missing, broken, or worn shields, guards, and other protective devices must be replaced at once and prior to operation to reduce the possibility of injury. (SNPS-02)



The Snow Plow power unit should be equipped with a fire extinguisher, rated for all fires, in an accessible and visible area. The fire extinguisher should be inspected routinely by a certified inspector for operational use and replaced as needed. Never obstruct access to the fire extinguisher. (SNPS-6)

OPERATOR SAFETY INSTRUCTIONS AND PRACTICES



NEVER use drugs or alcohol immediately before or while driving or operating the Snow Plow. Drugs and alcohol will affect an operator's alertness and coordination and therefore affect the operator's ability to operate the Equipment safely. Before operating the Equipment, an operator on prescription or over-the-counter medication must consult a medical professional regarding any side effects of the medication that would hinder their ability to operate the Equipment safely. **NEVER** knowingly allow anyone to operate this Equipment when their alertness or coordination is impaired. Serious injury or death to the operator or others could result if the operator is under the influence of drugs or alcohol. (SNPD-3)



Always wear OSHA approved Personal Protective Equipment (PPE) while operating, servicing, repairing, and/or cleaning the Equipment. PPE is designed to provide bodily protection during such activities.

Personal Protective Equipment includes:

- Protective Eye Wear
- Steel Toed Safety Footwear
- Gloves
- Hearing Protection
- Close Fitted Clothing
- Hard Hat-When working around a raised hopper.
- Respirator-Depending on conditions and material being swept or cleaned.

Specialized protective equipment may be required if dangerous or hazardous material is being moved by the plow. (SNPD-4)

SAFETY

CAUTION

Prolonged operation of the Snow Plow may cause operator boredom and/or fatigue affecting the safe operation of the Snow Plow and Truck or Power unit. It is recommended that the operator take scheduled work breaks to help prevent these potentially impaired operating conditions. If possible, completely shut down the Equipment, exit the cab and move around stretching your arms and legs. Never operate the Equipment in a fatigued or bored mental state that impairs proper and safe Equipment operation. (SNPD-5)

CAUTION

PROLONGED EXPOSURE TO LOUD NOISE MAY CAUSE PERMANENT HEARING LOSS! Equipment operation can often be noisy enough to cause permanent hearing loss. We recommend that you always wear hearing protection if the noise in the Operator's position exceeds 80db. Noise over 85db over an extended period of time will cause severe hearing loss. Noise over 90db adjacent to the Operator over an extended period of time will cause permanent or total hearing loss. **Note:** *Hearing loss from loud noise [from sweepers, chain saws, radios, and other such sources close to the ear] is cumulative over a lifetime without hope of natural recovery.* (SNPD-6)



CAUTION

Prolonged operation of the Equipment in cold weather may cause operator hypothermia affecting the safe operation of the Snow Plow and Truck or Power unit. It is recommended that the operator wear appropriate clothing take scheduled work breaks to help prevent these potentially impaired operating conditions. If possible, completely shut down the Equipment, exit the cab and warm the body in a properly heated area. Never operate the Equipment in a fatigued or impaired mental state that effects the proper and safe Equipment operation. (SNPD-8)

WARNING

Use both hands for support when getting on and off the truck or power unit. Use handles and steps on the equipment for support when boarding. Never use the Truck or Snow Plow control levers for support when boarding the equipment. (SNPO-01)

WARNING

Use available truck or power unit handles and steps to exit the operator's station. Make sure you have solid footing before stepping down. Be careful of your step and use extra caution when mud, ice, snow, or other matter has accumulated on the steps or handrails. Never rush to exit or jump off the truck or power unit. (SNPO-02)

DANGER

Do not attempt to mount the Truck or Power Unit while the machine is moving. Never attempt to mount a runaway Snow Plow. Serious injury or death may occur from being run over by a moving Truck, Power Unit, or Snow Plow. (SNPO-03)

DANGER

BEFORE leaving the operator's seat, always engage the parking brake and/or set the Truck's or Power Unit's transmission in the park position, stop the engine, remove the key, and wait for all moving parts to stop. Never dismount a Truck or Power Unit that is moving or while the engines are running. Operate the equipment controls from the Operator's seat only. (SNPO-04)

SAFETY

⚠ WARNING

Always wear a seat belt while driving the equipment during operation and transport. Serious injury or even death could result from falling from the operator's station or from being involved in a collision. (SNPO-05)

⚠ DANGER

Start the engines only when seated and belted in the operator's seat. Operate the equipment controls only while properly seated with the seat belt secured around you. Inadvertent movement of the power unit or attachment components may cause serious injury or death to the operator and passersby. Read the truck or Power Unit operator's manuals for proper starting instructions. (SNPO-06)

⚠ DANGER

Do not operate, or perform maintenance to, the Equipment while wearing loose fitting clothing. Entanglement of loose clothing with the rotating elements can result in serious injury or death. Stay clear of all rotating elements at all times. (SNPD-7)

⚠ DANGER

Operate only in conditions where you have clear visibility of the area in daylight or with adequate artificial lighting. Never operate in darkness or foggy conditions where you cannot clearly see at least 50 feet in front and to the sides of the equipment. Make sure that you can clearly see and identify passersby, steep slopes, ditches, drop-offs, overhead obstructions, power lines, oversized debris and foreign objects. If you are unable to see these types of items, discontinue operation until visibility improves. (SNPO-8)

⚠ WARNING

When transporting the Snow Plow between locations, follow all local traffic laws and regulations. (SNPO-10)

⚠ WARNING

Operate at a speed that allows you to safely operate and control the Truck and Snow Plow. Safe plowing speed depends on street condition and the type and amount of debris being moved. Slow down for corners, curbs, parked cars, protruding signs and other obstacles. Use slow traveling speeds when operating on or near steep slopes, ditches, drop-offs, overhead obstructions, power lines, or when debris and foreign objects are to be avoided. (SNPO-13)

⚠ WARNING

Do not operate the Equipment if excessive vibration or noise exists. Shut down the equipment and the Truck or Power Unit engine. Inspect the Equipment to determine the source of the vibration or noise. If parts are loose, damaged, or missing, replace them immediately. Do not operate the Equipment until all necessary repairs have been performed. To reduce the possibility of property damage, serious injury, or even death, never operate the Equipment with missing or damaged components. (SNPO-16)

⚠ WARNING

Never attempt to plow debris that is too large for the Snow Plow (oversized objects such as broken limbs and discarded tires). Such objects may damage the snow plow components and cause serious mechanical damage to the equipment. If possible, carefully place such objects out of the Snow Plow and traffic path until properly removed by another means. (SNPO-17)

SAFETY

WARNING

Unplowed snow, piled ice and debris, and snow drifts left behind the equipment might pose a driving hazard to vehicle traffic colliding with the debris or losing traction on the material. It is recommended to post warning signs alerting driver's of the equipment operation presence and the need to reduce vehicle speed. If such hazards are left behind following the Snow Plows passage, the area should be plowed a second time and any remaining hazards removed by an alternative method. (SNPO-19)

WARNING

Use extreme caution when lowering the Snow Wing. Make sure no bystanders are close by or underneath the wing while lowering. Allow ample clearance around the equipment when lowering or raising the wing. Use extreme caution around obstructions including bystanders, passersby, curbs, buildings, and other property. Use the Truck's or Power Unit's horn to warn of danger when the wing is being lowered. Lower wing slowly and carefully. Sudden or unexpected dropping of wing could result in serious injury. (SNPO-24)

DANGER

Do not allow the Snow Plow to come in contact with potentially dangerous and/or hazardous material. Such hazards may include, but are not exclusively limited to, the following:

- Fire Hazards- Fuel spills, burning material,
- Chemical Hazards- Chemical spills, discarded chemical containers, batteries,
- Biological Hazards- Decaying Carcasses, BioMedical Waste,
- Radioactive Hazards-Radioactive Waste, Radioactive Material,
- Carcinogenic Materials-Asbestos,
- Corrosive Materials-Batteries, Acids and Bases.

In most areas, these types of material require special handling requirements for safe and proper disposal and should not be plowed by the Snow Plow, nor can they be disposed of in a general landfill site like most swept waste. Contact the appropriate authority for the collection and disposal requirements of such dangerous and/or hazardous material. (SNPO-25)

DANGER

Always wear required OSHA approved Personal Protective Equipment (PPE) when coming in contact with and removing potentially dangerous and hazardous material that has collected on the Snow Plow equipment or which is obstructing one or more components. Pay close attention to dangerous and hazardous material including, but not exclusively limited to, chemicals, decaying carcasses and sharp objects. (SNPO-26)

WARNING

Verbal communication near a Truck or Power Unit and Snow Plow is difficult and dangerous. Operating instructions and directions should be made prior to starting the equipment. Unclear and misunderstood communication may lead to operator and bystander injury or death and equipment damage. If communication by the operator is necessary, completely shutdown and exit the equipment. Never allow anyone to approach the equipment while in operation. (SNPO-28)

DANGER

Never allow children to play on, under, or around the Truck or Power Unit nor allow children to operate equipment controls. Children can slip or fall off the equipment and be injured or killed. Children can cause the equipment components to shift or fall crushing themselves or others. (SNPO-29)

SAFETY

⚠ WARNING

Allow passengers only in situations where their presence is involved in the operation (operator training, supervision, maintenance inspection). Never carry passengers whose presence distracts from the safe operation or transport of the equipment. Passengers must be seated securely and belted in the cab's passenger seat. Never allow any person to ride on any other location of the Truck, Power Unit or Snow Plow during operation or transport. (SNPO-30)

⚠ WARNING

Extreme caution should be used by the operator when operating near passersby. Stop snow plowing if a passerby comes within 25 feet of the plow to prevent possible passerby injury or death from being struck by the equipment or from a thrown object. (SNPO-31)

⚠ CAUTION

Under certain conditions, the Snow Plow is capable of propelling objects up to 75 feet. Be extremely careful when plowing at higher speeds and hitting large dense objects, such as rocks, chunks of frozen ice, metal objects, broken glass, or other solid objects that might become propelled and cause bodily injury to passersby or damage to property such as windows and vehicles. (SNPO-32)

⚠ WARNING

Make sure that no bystander, animal or obstruction such as a vehicle, building, or street sign are within the width of the Snow Plow. The design of the Snow Plow may impair the operator vision when operating. Use extreme caution to ensure that the Snow Plow is not driven into the path of pedestrian or vehicle traffic. Serious injury or death and property damage could result from running into, being crushed by, or run over by a Snow Plow. (SNPO-33)

⚠ DANGER

Make sure no bystanders or animals are within 25 feet of the equipment basket when dumping contents from or cleaning the Snow Basket. Bucket contents, which may exceed several thousand pounds, could fall and crush a bystander or an animal resulting in possible injury or death. (SNPO-34)

⚠ WARNING

On fully assembled unit, do not remove the wing retaining chain until hoses are attached to the power unit and the wing folding cylinders have been filled with oil. Lower wings slowly and carefully. Keep bystanders clear of area when lowering wings. Sudden or unexpected dropping of wing could result in serious injury. (SNPO-36)

⚠ DANGER

Use extreme caution when operating the Equipment in traffic. To alert motorists of the Equipment's presence, use all equipped warning signals to alert motorists and pedestrians of the equipment's presence and relatively slow speed. Serious injury or death and property damage may occur if a vehicle collides with this Equipment. (SNPS-3)

⚠ WARNING

Before starting a snow plowing operation, make sure all the warning signal lights are connected, visible and working. Routinely inspect the equipment's headlights, brake lights, backup lights, and turn signal lights for operational condition. Immediately repair non-functioning lighting. Always follow all local traffic regulations while operating the Snow Plow. (SNPS-4)

SAFETY



Always turn on all safety lights and flashers when you operate the Snow Plow. (SNPS-5)



Be particularly careful in transport. The Implement has raised and moved the center of gravity to the front of the Power Unit increasing the possibility of overturn and tipping forward. Turn curves or go up slopes only at low speed and using a gradual turning angle. Go up slopes with the Implement located uphill. Slow down on rough or uneven surfaces. (SPU-2)

CONNECTING OR DISCONNECTING IMPLEMENT SAFETY INSTRUCTIONS AND PRACTICES



Do not stand or allow bystander or coworkers between the attachment and the truck or power unit while installing or disconnecting the attachment. Keep hands and body clear of the attachment and the attachment mounts. Serious injury or death can result from a person being crushed between the attachment and truck or power unit. (SNPC-01)

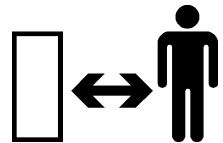

Reset the tripped snow plow edge by raising the snow plow off the ground. DO NOT attempt to reset the trip edge by hand. The trip edge is spring loaded and sudden and unexpected movement can occur resulting in serious injuries. Keep hands and feet away from the trip edge. If the trip edge does not reset, stop plowing and have the snow plow repaired before resuming snow plowing. (SNPO-12)



Make sure the implement is properly attached to the Power Unit and the retaining pins securely lock the Implement into position. Improper mounting of the Implement onto the Power Unit can result in the Implement falling causing serious injury. (SNPC-02)



The operator of the equipment must be trained in the operation and safe use of this machine. The operator must read and completely understand the operator's manuals of the Snow Plow, Truck or Power unit manufacturers. New operators should be trained in an open area clear of obstructions before operating on public roadways. If operation of the entire Snow Plow unit (Truck or Power unit) is not completely understood, consult your authorized sales representative for a detailed explanation. Never allow an untrained or unqualified driver to operate the Snow Plow. (SNPD-1)



The Snow Plow driver must meet the requirements and possess a Motor Vehicle License as determined by the state in which the Snow Plow is operated if used on public roadways. Contact your local State Department of Public Safety office for special licensing requirements to operate the Snow Plow in your area. (SNPD-2)

SAFETY

MAINTENANCE AND SERVICE SAFETY INSTRUCTIONS AND PRACTICES

▲WARNING

Perform service, repairs and lubrication according to the maintenance section. Ensure the unit is properly lubricated as specified in the lubrication schedule and all bolts and nuts are properly torqued. Failure to properly service, repair and maintain this Implement in good operating condition could cause component failure and possible serious injury or even death. (SG-35)

▲WARNING

Periodically inspect all moving parts for wear and replace when necessary with authorized service parts. Look for loose fasteners, worn or broken parts, and leaky or loose fittings. Make sure all pins are properly secured. Serious injury may occur from not maintaining this equipment in good working order. (SNPM-01)



▲WARNING

Inspect the entire Snow Plow before each use. Accidents may occur or damage to the equipment may result if the Snow Plow is not maintained in good mechanical working order.

- Check for loose bolts, worn or broken parts, pinched hydraulic hoses, and leaky or loose fittings.
- Make sure all pins are secure and safety pin equipped.
- Make sure replacement parts are the correct size and properly installed.
- Make sure all fluid levels are full and replenish as necessary.
- Make sure fuel, oil, and coolant caps are replaced and tightened.
- Check tire condition for tread wear and tire pressure at the rated PSI.
- Make sure that all safety shields and guards are attached and in good condition.
- Make sure all scheduled maintenance is up to date. (SNPM-02)

▲WARNING

Do not modify or alter this Snow Plow. Do not permit anyone to modify or alter this equipment, any of its components or any Snow Plow function. Modification can result in equipment failure and cause serious injuries to the operator, coworkers, or bystanders. (SNPM-03)

▲WARNING

Use extreme care when climbing onto the equipment to perform repairs, maintenance, and cleaning. Use proper stands and ladders to access areas that cannot be reached from ground level. Slipping and falling off the equipment can cause serious injury or death. (SNPM-04)

▲WARNING

Never attempt to repair, lubricate, adjust, clean, remove obstructions or perform any other type of service to any component while the Snow Plow is in motion or while the engine is running. Completely shut down the engine and wait for all motion to come to a complete stop before servicing the Snow Plow. (SNPM-05)

SAFETY

DANGER

Never leave the Snow Plow unattended while the plow is in the raised position. Accidental operation of the lifting lever or a hydraulic failure may cause a sudden drop of the unit which could result in injury or death by crushing. If the plow must be raised for inspection or service securely block up and support the Plow to prevent it falling. (SNPM-06)

DANGER

Never crawl under the Snow Plow or any raised component unless it is properly blocked up and support to prevent it from falling. Accidental operation of a lifting lever or hydraulic failure may cause a sudden drop of the unit with injury or death by crushing. (SNPM-07)

WARNING

Use proper protective equipment including gloves, safety eye wear, arm protection when handling plow blades and components during replacement, adjustment, and maintenance. Plow edges and components can become sharp and have burrs that could inflict puncture and cuts to the hands, arms, and/or eyes if proper protective equipment is not worn.

(SNPM-08)

WARNING

Replace bent, cracked, or broken plow blade with a new blade. Never attempt to straighten or weld on plow blades because this will likely crack or otherwise damage the blade with subsequent failure and possible serious injury from broken blade being ejected from plow. (SNPM-10)

DANGER

Escaping pressurized hydraulic oil generated by hydraulic pumps has the potential to inflict serious injury and possible death. Never attempt to repair a pump or hose or tighten a connection while the system is pressurized. Always shut down the engine and relieve hydraulic oil pressure before performing any repairs to the hydraulic system. (SNPM-11)

WARNING

Hydraulic pressure must be relieved from the hydraulic circuit prior to doing any maintenance or repair work and when the Snow Plow is parked at the end of the day. Place the Snow Plow(s) on the ground or securely blocked up. Turn off the Truck engine then engage the hydraulic remote cylinders several times to relieve hydraulic pressure prior to performing any maintenance or repair work. (SNPM-12)

WARNING

Never remove debris from or unclog jams in the plow or lifting components until the engine have been completely shutdown and all components have come to a complete stop and are lowered to ground level and hydraulic pressure relieved. Always wear PPE when removing collected material and debris from the equipment. Serious injury or death may occur if any of these precautions are not followed when removing plugged or entangled debris. (SNPM-15)

WARNING

Engine Exhaust, some of its constituents, and certain vehicle components contain or emit chemicals known to the state of California to cause cancer and birth defects or other reproductive harm. (SNPM-20)

SAFETY

⚠ DANGER

Do not operate this equipment with hydraulic oil or fuel leaking. Oil and fuel are expensive and their presence could present a hazard. Do not check for leaks with your hand! High-pressure oil streams from breaks in the line could penetrate the skin and cause tissue damage including gangrene. To check for a hose leak, SHUT the ENGINE OFF and remove all hydraulic pressure. Wear oil impenetrable gloves, safety glasses and use Cardboard to check for evidence of oil leaks. If you suspect a leak, REMOVE the HOSE and have it tested at a Dealer. If oil does penetrate the skin, have the injury treated immediately by a physician knowledgeable and skilled in this procedure. (SNPM-21)



⚠ WARNING

Always read carefully and fully comply with the manufacturers instructions when handling fuels, oils, solvents, cleansers, and any other chemical agent. (SNPM-22)

⚠ WARNING

Battery posts, terminals and related accessories contain lead and lead compounds, chemicals known to the state of California to cause cancer and birth defects or other reproductive harm. Wash Hands after handling. (SNPM-23)

⚠ WARNING

Avoid contact with hot surfaces on the bottom of the skid shoes or plow cutting edges. Use gloves and eye protection when servicing hot components. Contact with a hot surface can cause serious injury from burns or scalding. (SNPM-24)

⚠ WARNING

Remove the negative battery cable from the battery before performing any maintenance on the electrical system to prevent an accidental circuit shorting and sparks. Sparks can result in wiring damaged, fire or personal injury. (SNPM-25)

⚠ WARNING

DO NOT allow any person under a folded wing unless wing is securely supported or locked up with the safety chain. Never work under a lifted component unless the component is securely supported or blocked up. Keep bystanders clear of area when lowering wings. Sudden or unexpected dropping of wing could result in serious injury. (SNPM-26)

⚠ WARNING

Before conducting maintenance on the Snow Plow stop the truck or Power Unit, place the transmission in the park position and set the parking brake. Turn the engine off and remove the key to prevent inadvertent or accidental starting of the engine. Unexpected engine start up or vehicle movement can result in serious bodily injuries or death. (SNPM-27)

SAFETY

TRANSPORTING SAFETY INSTRUCTIONS AND PRACTICES

▲WARNING

Secure the wing for transport when not plowing. Secure wing in transport position using wing transport safety chain. Sudden or unexpected dropping of wing could result in serious injury. (SNPO-35)

▲WARNING

Transport the Truck, Power Unit, and Snow Plow only at safe speeds. Serious accidents and injuries can result from driving this equipment at unsafe speeds. Become familiar with the driving characteristics of the equipment and how it handles before operating or transporting on streets and highways. Make sure the Truck's or Power Unit's steering, brakes, and wheels are in good condition and operate properly)

Before transporting the Equipment determine the safe transport speeds for you and the machine. Make sure you abide by the following rules:

- Test the Truck or power unit and Snow Plow at a slow speed and increase the speed slowly. Apply the brakes smoothly to determine the stopping characteristics of the Truck equipped with the Snow Plow. As you increase the speed of the Truck, the stopping distance increases. Determine the maximum safe transport speed for you and the equipment. When driving down a hill or on wet or icy roads, the braking distance increases: use extreme care and reduce your speed. Do not operate the equipment with weak or faulty brakes.
- Obey all traffic laws and regulations. Never exceed the posted speed limit.
- The Snow Plow has moved the center of gravity of the equipment forward. Use extreme caution when transporting at highway speeds. Slow down for sharp corners or on slopes to avoid loss of steering control.
- Only transport the equipment at the speeds determined as safe and which allow for proper control of the machine while driving and stopping during an emergency.
- When operating in traffic, use the Truck's or Power Units directional indicator or signal lights to indicate your movement. Always use the flashing warning lights and other equipped warning features to alert motorist of your presence and slow moving speed when operating in traffic. **Be Aware of Traffic Around You and Watch Out for the Other Guy.** (SNPO-09)

SAFETY

SAFETY

Federal Laws and Regulations

This section is intended to explain in broad terms the concept and effect of federal laws and regulations concerning employer and employee equipment operators. This section is not intended as a legal interpretation of the law and should not be considered as such.

Employer-Employee Operator Regulations

U.S. Public Law 91-596 (The Williams-Steiger Occupational and Health Act of 1970) OSHA

This Act Seeks:

“...to assure so far as possible every working man and woman in the nation safe and healthful working conditions and to preserve our human resources...”

DUTIES

Sec. 5 (a) Each employer-

- (1) shall furnish to each of his employees employment and a place of employment which are free from recognized hazards that are causing or are likely to cause death or serious physical harm to his employees;
- (2) shall comply with occupational safety and health standards promulgated under this Act.
- (b) Each employee shall comply with occupational safety and health standards and all rules, regulations and orders issued pursuant to this Act which are applicable to his own actions and conduct.

OSHA Regulations

OSHA regulations state in part: “At the time of initial assignment and at least annually thereafter, the employer shall instruct every employee in the safe operation and servicing of all equipment with which the employee is, or will be involved.”

Employer Responsibilities:

To ensure employee safety during plow and truck or other power unit operation, it is the employer’s responsibility to:

1. Train the employee in the proper and safe operation of the plow and truck or other power unit.
2. Require that the employee read and fully understand the plow and truck or other power unit Operator’s manual.
3. Permit only qualified and properly trained employees to operate the plow and truck or other power unit.
4. Maintain the plow and truck or other power unit in a safe operational condition and maintain all shields and guards on the equipment.
5. Ensure the truck or other power unit is equipped with a functional ROPS and seat belt and require that the employee operator securely fasten the safety belt and operate with the ROPS in the raised position at all times.
6. Forbid the employee operator to carry additional riders on the Tractor or Implement.
7. Provide the required tools to maintain the plow and truck or other power unit in a good safe working condition and provide the necessary support devices to secure the equipment safely while performing repairs and service.
8. Require that the employee operator stop operating equipment if bystanders or passersby come within 25 feet.

Child Labor Under 16 Years of Age

Some regulations specify that no one under the age of 16 may operate power machinery. It is your responsibility to know what these regulations are in your own area or situation. (Refer to U.S. Dept. of Labor, Employment Standard Administration, Wage & Home Division, Child Labor Bulletin #102.)

ASSEMBLY SECTION

ASSEMBLY

Before attempting to mount or service your Tiger equipment, it is important to read and understand all of the information in the Safety Section of this manual.

Check complete shipment list against the packing list to make sure there are no shortages. Make certain the tractor model is the appropriate one for the mower received!

WARNING!



Always use a floor jack, hoist or fork lift to lift and raise heavy parts.

Read and understand the entire Assembly Section instructions before attempting to mount your Tiger mower. Refer to the Parts Section of this manual for detailed illustrations to locate all parts.

ASSEMBLY

MULTIPLIER VALVE CONTROLLER MOUNTING

The Multiplier Valve Controller comes with two worm-screw ties that are used to attach the Controller to the Tractor Joystick as shown below.

The Multiplier Valve Controller can also be attached to the tractor's joystick by removing the joystick handle, drilling two holes, and using the 10-32 machine screws and nylock nuts which are provided.

MULTIPLIER VALVE CONTROLLER WIRING

The red wire coming out of the bottom of the controller should be routed inside the tractor cab and inserted into the Tractor Auxillary Plug-in. The cable wires should be routed through the rear window of the tractor cab to the Multiplier Valve.

- Black wire: Top button on controller.
- White wire: 2nd button on controller.
- Orange wire: 3rd button on controller.
- Green wire: 4th button on controller.

Black wire



ASSEMBLY

HYDRAULIC MULTIPLIER VALVE MOUNTING

Align the mounting bracket to the existing holes on rear of the tractor by the PTO. Secure the bracket to the tractor with the existing hardware. Then align the holes and secure the valve to the mounting bracket as shown in the Parts Section. Install the electrical control wires from the controller that are routed through the rear window of the cab. See previous page for wire designation. Install the hydraulic lines from the Multiplier Valve to the tractor remotes.

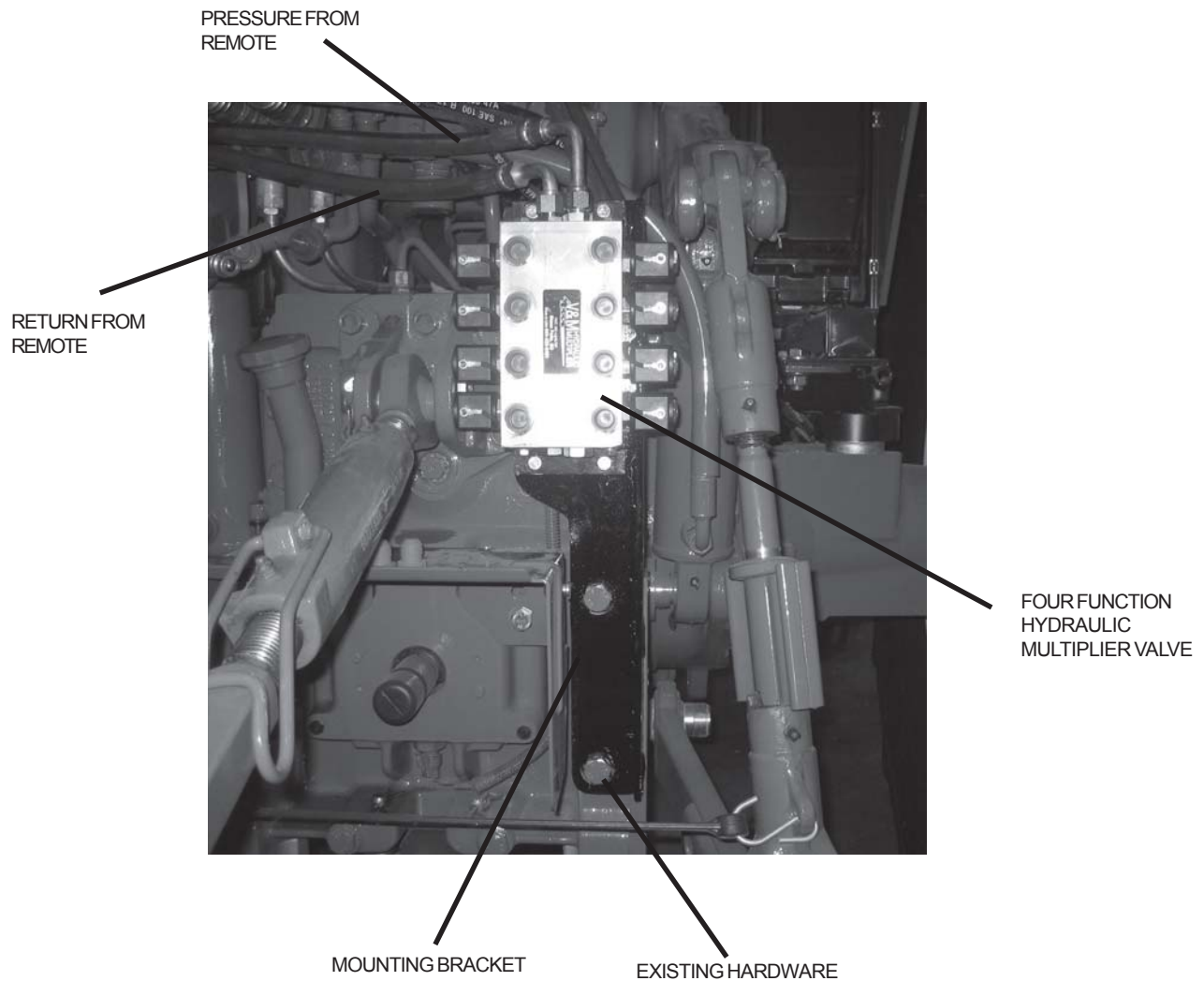

ASSEMBLY

HYDRAULIC SYSTEM DIAGRAM

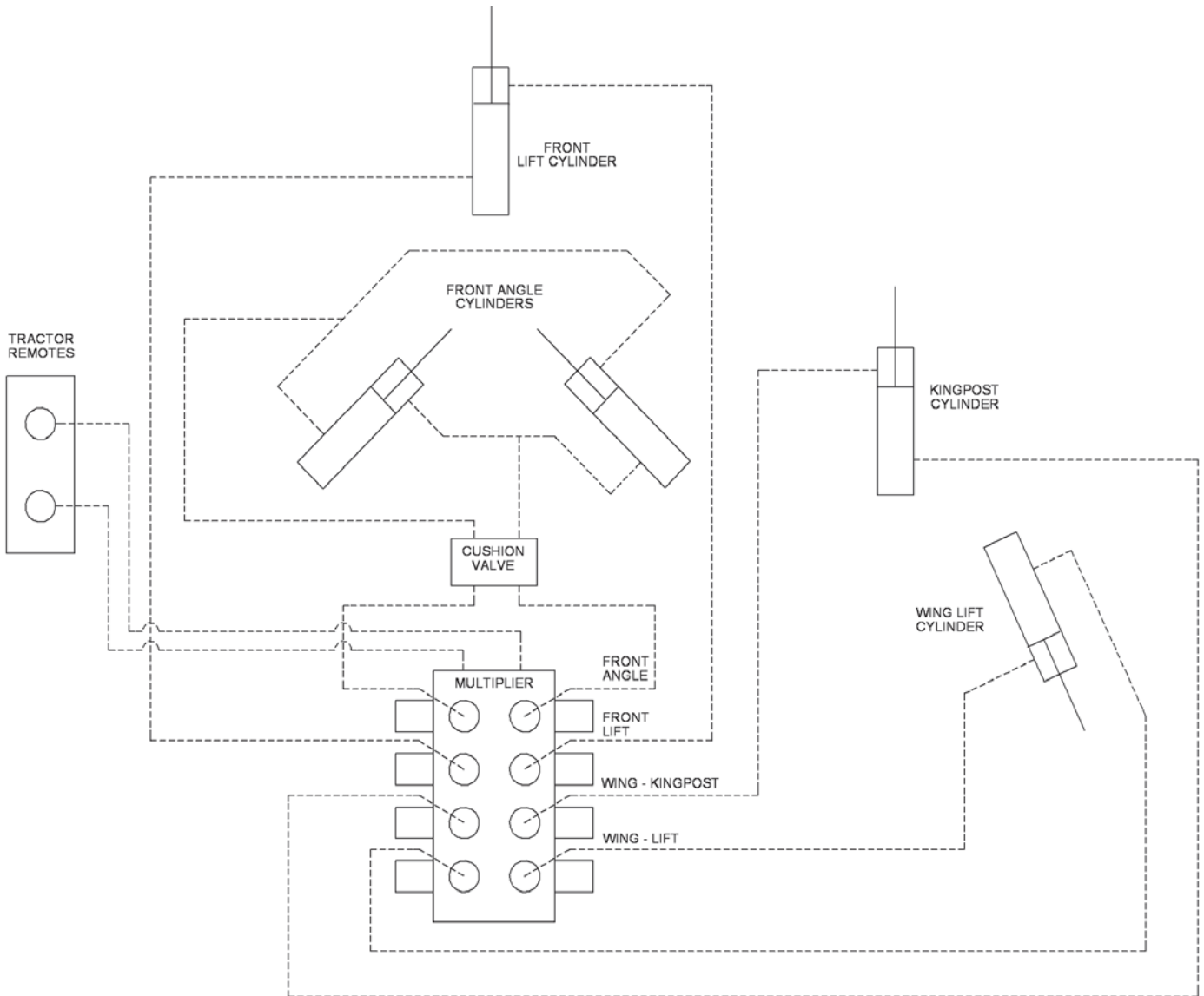

ASSEMBLY

3-POINT PUSH ARM STOP MOUNTING

Install the Push Arm Stop onto the 3-point hitch using the pins as shown in the parts illustration. Adjust the bottom arms so the Push Arm Stop is 17" to the ground at the Pivot Boss. Adjust the top link so that the Push Arm Stop is approximately level with the ground.

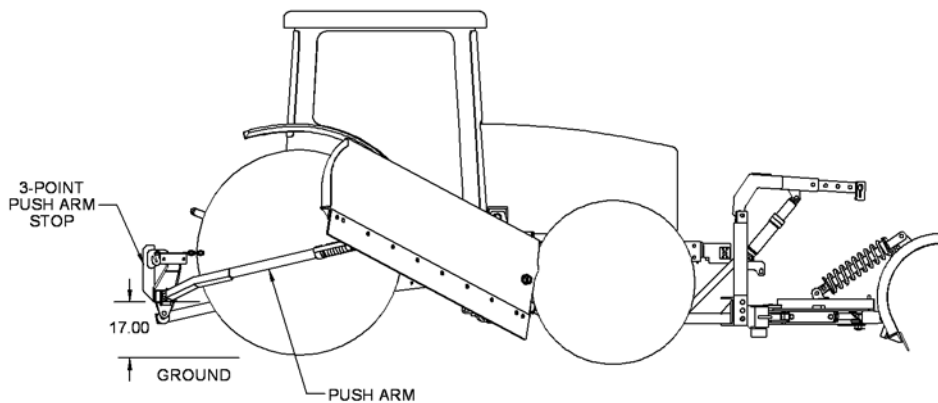

SIDE VIEW

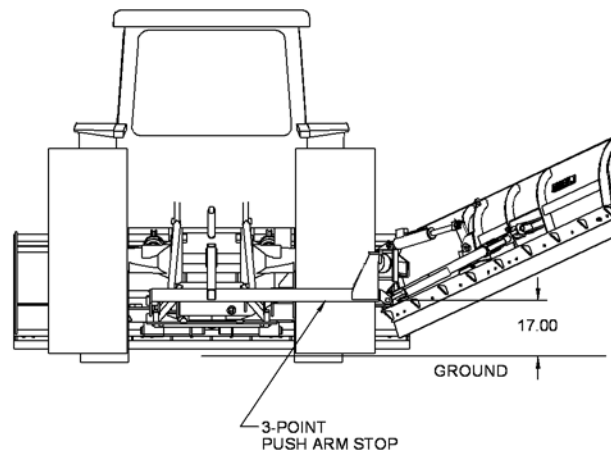

REAR VIEW

ADJUSTING REAR WHEELS

Follow the instructions in the tractor owner's manual for adjusting tires and rims. The rear wheels MUST be adjusted to the widest setting. NOTE: This may require switching the wheels to opposite sides of the tractor. Also take note of any width restrictions when transporting by trailer. (For ease of installation, it is best to leave rear wheels removed during installation of the mower).

ASSEMBLY

WELDING MAIN FRAME

Make sure you use the appropriate safety equipment. Weld the Tangs onto your existing Mainframe as shown below. Next, weld on the Bosses making sure the orientation of the cross holes for the bolts are correct.

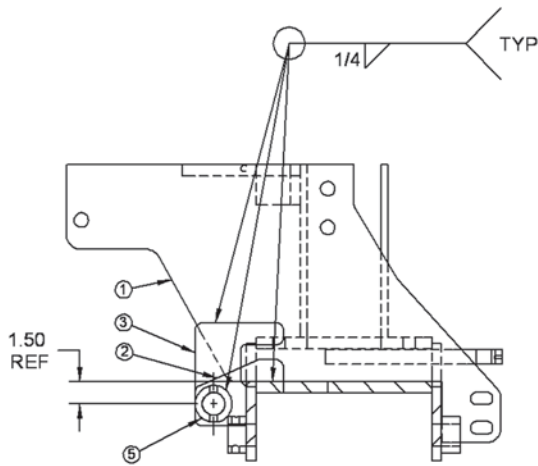
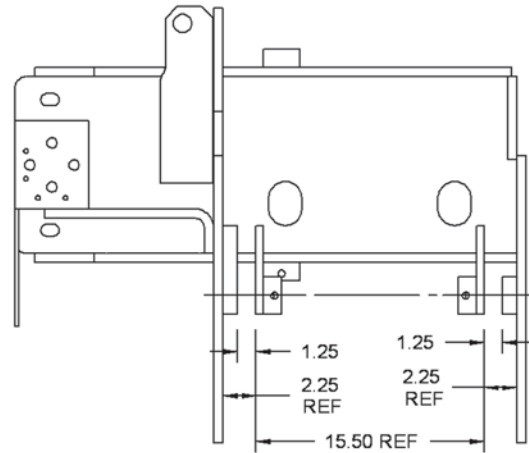

SECTION A-A

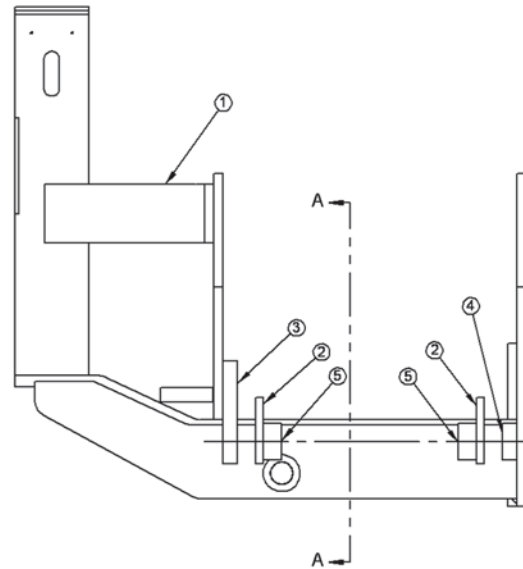

ITEM	PART NO.	QTY	DESCRIPTION
1	06300059	*	MAIN FRAME
2	06401066	2	TANG,LEFT,MNFRM
3	06401067	1	TANG,RIGHT,MNFRM
4	06470013	1	BOSS,2.50OD x 1.56ID x 1.00
5	23387A	2	BOSS,2.50OD x 1.53ID x 1.25

ASSEMBLY

FINAL PREPARATION FOR OPERATION

Place operator's safety and operation decals on the steering column and side counsel where they are clearly visible to the operator. These decals should be understood by each operator of the machine in conjunction with the Safety and Operation Section of this book. The decals are to be maintained in good condition as a reminder to the operator and should be replaced if damaged.

Finally, all bosses, pins and pivot points will need to be greased as instructed in the Maintenance Section of this manual. The hydraulic reservoir can also be filled with the recommended fluid (see maintenance section) and the filter installed in the top of the tank. Double check all fittings and fasteners BEFORE starting tractor. Also secure any loose hoses together with zip ties and wrap with split hoses where friction may occur on the hoses.

WARNING!



BEFORE starting or operating the tractor you must read and understand the Safety and Operation Sections of this manual completely.

BE SURE THE BALL VALVES ARE OPEN! Start tractor and allow instruments to stabilize. Using a piece of paper or cardboard as noted in the safety and maintenance sections, check all fittings and connections for hydraulic leaks.

If a leak is found, you must shut down the tractor , set the cutter on the ground. Before attempting to fix the leak, you must actuate the lift valve handles several times to relieve any pressure in the lines.

Before operating the plows , the front and side plows should be slowly moved throughout the full range of motion. Watch for any condition that would cause pinching or excess stress on the hoses. The steering and front axle travel should also be carefully moved through their full range of motion. If any condition occurs in which the hoses contact the tires, the steering and / or front axle travel may need to be limited as described in the tractor operator's manual. This should also be done if the tires rub, or are extremely close to any other part of the plow. This may include adding shims, or adjusting stop bolts in the tractor front to solve the problem. While checking motion, you should also check that the control circuits are connected according to the operators decal for the valve handles.

OPERATION

**OPERATION
SECTION**

OPERATION

Safety is of primary importance to the owner / operator and to the manufacturer. The first section of this manual includes a list of Safety Messages, that, if followed, will help protect the operator and bystanders from injury or death. Many of the messages will be repeated throughout the manual. The owner / operator / dealer should know these Safety Messages before assembly and be aware of the hazards of operating this mower during assembly, use, and maintenance.

The **Safety Alert Symbol** combined with a signal word, as seen below, is intended to warn the owner / operator of impending hazards and the degree of injury possible during operation.

DANGER!



Indicates an imminently hazardous situation that, if not avoided, **WILL** result in DEATH OR VERY SERIOUS INJURY.

WARNING!



Indicates an imminently hazardous situation that, if not avoided, **COULD** result in DEATH OR SERIOUS INJURY.

CAUTION!



Indicates an imminently hazardous situation that, if not avoided, **MA** result in MINOR INJURY.

IMPORTANT!

Identifies special instructions or procedures that, if not strictly observed, could result in damage to, or destruction of the machine, attachments or the environment.

NOTE: *Identifies points of particular interest for more efficient or convenient operation or repair.* (SG-1)

CAUTION!



Before any operation of tractor and equipment, the user should read and understand the safety and operating instructions for both the tractor and the equipment. The user should also be familiar with the location and functions of the units instruments and controls. Being familiar with the machine and its controls will increase efficiency and reduce possibility of serious injury or damage to the unit. The operator should work slowly and carefully until he feels comfortable with the machine. Speed and skill will be attained much easier if the necessary time is spent to familiarize yourself with the machine and its operations.

Since tractor makes and models vary, we recommend reading and following the operator's manual provided by the manufacturer pertaining to your particular unit.

OPERATION

PUSH ARM STOP POSITION

The Push Arm Stop height is controlled with the 3-point hitch control lever. Follow the instructions for this control in the tractor operator's manual. The 3-point should be set in its lowest position. With the 3-point in its lowest position, adjust the 3-point arms so that the Push Arm Stop is level to the ground.

WARNING!



After the first day of operation, all bolts should be checked and tightened securely. This should be done periodically to ensure the bolts do not become loose and cause damage to the tractor or mower, or injury to the operator.

TRANSPORTING PLOWS

When driving from one site to the next, the following procedure should be followed.

The Front Plow should be raised to its highest position. The chains should be repositioned to be tight with the plow raised.

The Side Plow should be raised to its transport position. First, raise the Kingpost all the way to its top position. Secondly, bring the plow up by contracting the swing cylinder. Verify that the Push Arm is contacting the rubber stop on the Push Arm Stop. If the side plow isn't against the rubber stop, lower the plow a couple of feet and then raise it back up. Recheck the position of the plow. When the plow is raised all the way up and against the rubber stop, shut the tractor off and walk around to the back to strap the chain around the Push Arm.

OPERATION

TRANSPORTING PLOW ON A TRAILER

Transporting unit by flatbed trailer:

Most tractors with a side mounted plow attached will be over legal transporting width (102" wide). For this reason, one of the following procedures must be followed.

1: Transporting with side plow attached: Use a loading dock or ramp to load tractor onto the trailer. Center the tractor with the plows attached between the sides of the trailer. Make sure the side plow is fully raised and secured. Secure the tractor to the trailer with chains. Obtain proper over-width permits and mark the vehicle and plow as over-width as required by law. Check the tractor operator's manual for any tractor requirements to transport by flatbed trailer.

2: Transporting with side plow removed: Park the tractor and turn the engine off. Center the tractor and the plows between the sides of the trailer. Secure the tractor and the plows to the trailer with chains.

OPERATION



TRACTOR PRE-OPERATION Inspection

Tractor ID# _____ Make _____

Date: _____ Shift _____

WARNING!



Before conducting the inspection, make sure the Tractor engine is off, all rotation has stop and the tractor is in the Park with the parking brake engaged. The Mower head is resting on the ground (or is securely blocked up and supported) and all hydraulic pressure has been relieved.

Item	Condition at Start of Shift	Specific Comments if not O.K.
The Flashing lights function properly		
The SMV Sign is clean and visible		
The Tires are in good condition with proper pressure		
The Wheel Lug bolts are tight		
The tractor Brakes are in good condition		
The Steering linkage is in good condition		
There are no visible Oil Leaks		
The Hydraulic controls function properly		
The ROPS or ROPS Cab is in good condition		
The Seatbelt is in place and in good condition		
The 3-Point Hitch is in good condition		
The Drawbar pins are securely in place		
The PTO Master Shield is in place		
The Engine Oil level is full		
The Brake Fluid level is full		
The Power Steering Fluid Level is full		
The Fuel level is adequate		
The Engine Coolant Fluid level is full		
The Radiator is free of debris		
The Air filter is in good condition		

Operators Signature: _____

DO NOT OPERATE an UNSAFE TRACTOR or MOWER

OPERATION

MAINTENANCE SECTION

IN SEASON MAINTENANCE

Snow removal equipment must be cared for and maintained regularly. Daily or pre-route inspection and maintenance are necessary. Failure to do so may affect efficiency and safety.

A visual inspection must be carried out after every 8 hours of operation. Look for damaged components, bends, cracked welds or hydraulic leaks. **REPAIR IMMEDIATELY!** It is recommended to re-torque all bolts after the first 8 hours of use and to regularly check for loosened or missing fasteners. Replace any damaged or missing fasteners immediately.

Because of the environment in which snow equipment is expected to operate, hydraulic lines, fasteners, wearable or replaceable items and warning decals may become damaged by snow, ice and road debris. These items must be inspected daily and replaced if necessary to avoid equipment damage or personal injury.

Lubrication of moving parts is of the utmost importance. Exposure to snow, ice, salt and road debris will wash away lubrication quickly and it may be necessary to inspect and reapply lubrication more than once a day.

END OF SEASON MAINTENANCE

GROUND ENGAGING COMPONENTS

CUTTING EDGES & GUARDS

Replace any broken cutting edges, unevenly or excessively worn cutting edges, and broken or worn wear guards.

RUNNING GEAR

Replace broken, worn, or missing running gear shoes, and any damaged adjuster leg components. Grease internal threads and sliding members (it's best to disassemble and grease directly; zerks aren't as effective at greasing these areas).

HARDWARE

Replace missing or broken bolts. Proper torque is important! Use grade 8 plow bolts for steel cutting edges.

HYDRAULICS

HOSES

Plug or cap any QC fittings or any open hose ends. Inspect hoses for any leaks or potential leaks. Secure hoses with hose clamps.

CYLINDERS

Check for leaks, and any chrome rod dents or scratches. (If v-stack rod end seals are leaking, a ¼ turn of the pack nut will often stop a small leak). Apply a light coat of oil or grease on exposed rod surfaces.

FRAME AND MOLDBOARD

JOINTS

Check pins, bushings, and pivot bolts for wear. Make sure all keepers are in place. Make sure shear bolts and pins are same as original equipment (usually grade 2). Some drivers don't like replacing shear pins and will install grade 8 replacements to avoid replacing during a storm. These items are *designed to shear* to protect the driver and the equipment. **CHECK WELDMENTS FOR CRACKS.**

REPLACE WORN OR BROKEN PARTS FOUND BY ABOVE INSPECTIONS.

NOTES



JD6X30 SNOW PLOW

PARTS SECTION

PARTS ORDERING GUIDE

The following instructions are offered to help eliminate needless delay and error in processing purchase orders for the equipment in this manual.

1. The Parts Section is prepared in logical sequence and grouping of parts that belong to the basic machine featured in this manual. Part numbers and descriptions are given to help locate the parts and quantities required.

2. The Purchase Order must indicate the **Name and Address** of the person or organization ordering the parts, **who should be charged**, and if possible, the **serial number of the machine** for which the parts are being ordered.

3. The purchase order must clearly list the **quantity of each part**, the complete and correct **part number**, and the basic **name of the part**.

4. The manufacturer reserves the right to substitute parts where applicable.

5. Some parts may be unlisted items which are special production items not normally stocked and are subject to special handling. Request a quotation for such parts before sending a purchase order.

6. The manufacturer reserves the right to change prices without prior notice.

NOTE: When ordering replacement decals, refer to the part numbers and descriptions listed in the safety section in the front of this manual.



1000

For maximum safety and to guarantee optimum product reliability, always use genuine **Tiger** replacement parts. The use of inferior replacement parts may cause premature or catastrophic failure which could result in serious injury or death.

Direct any questions regarding parts to:

Tiger Corporation
3301 N. Louise Ave.
Sioux Falls, SD 57107
1-800-843-6849
1-605-336-7900

PARTS SECTION TABLE OF CONTENTS

SECTION	PAGE
TRACTOR SPECIFIC PARTS:	
TRACTOR MOUNT KIT - MAIN FRAME	5-4
TRACTOR MOUNT KIT - FRONT HYDRAULICS	5-5
TRACTOR MOUNT KIT - PUMP HOSES	5-6
TRACTOR MOUNT KIT - SIDE HYDRAULICS	5-8
3-POINT STOP & PUSH ARM	5-10
MULTIPLIER VALVE MOUNTING	5-12
3 & 4 FUNCTION MULTIPLIER VALVE BREAKDOWN	5-13
2 FUNCTION MULTIPLIER VALVE BREAKDOWN	5-14
1 FUNCTION MULTIPLIER VALVE BREAKDOWN	5-15
SAFETY LIGHTS	5-16

TRACTOR MOUNT KIT - MAINFRAME

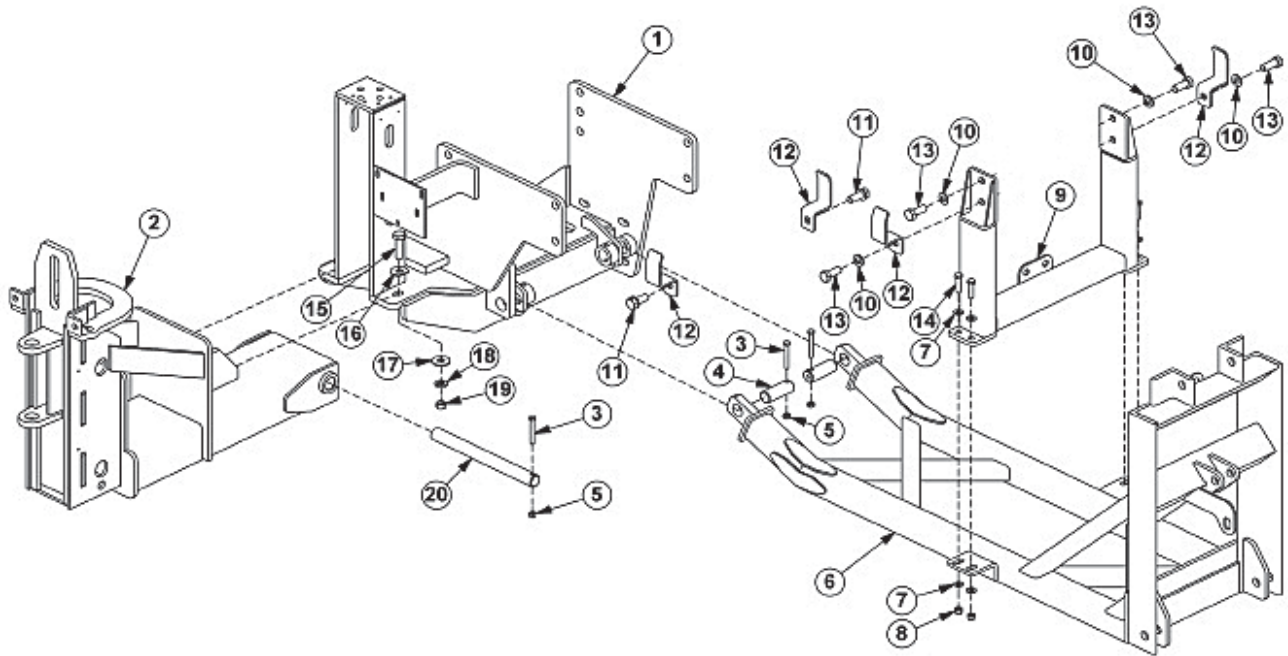

ITEM	PART NO.	QTY	DESCRIPTION
1	REF	*	MAIN FRAME
2	06300118	1	SIDE PLOW WELDMENT
3	21688	3	CAPSCREW,7/16 x 3-1/4,NC
4	06420125	2	PIN,1.50 X 4
5	21677	3	NYLOCK NUT,7/16,NC
6	06300116	1	PUSH FRAME
7	33764	8	FLATWASHER,5/8,SAE,GR8
8	21777	4	NYLOCK NUT,5/8,NC
9	06300113	1	HANGER FRAME
10	33880	4	FLATWASHER,3/4,SAE,GR8
11	—	2	CAPSCREW *EXISTING TRACTOR HARDWARE
12	32382	4	CLAMP,HOSE
13	28399	4	CAPSCREW,20MM x 80MM,2.5P,GR10.9
14	6T2289	4	CAPSCREW,5/8 x 2,NC,GR8
15	21835	2	CAPSCREW,3/4 x 2-3/4,NC
16	6T2607	2	FLATWASHER,3/4,CUT
17	22021	2	FLATWASHER,3/4
18	21993	2	LOCKWASHER,3/4
19	21825	2	HEX NUT,3/4,NC
20	6T3001	1	PIN,1-1/2

TRACTOR MOUNT KIT - FRONT HYDRAULICS

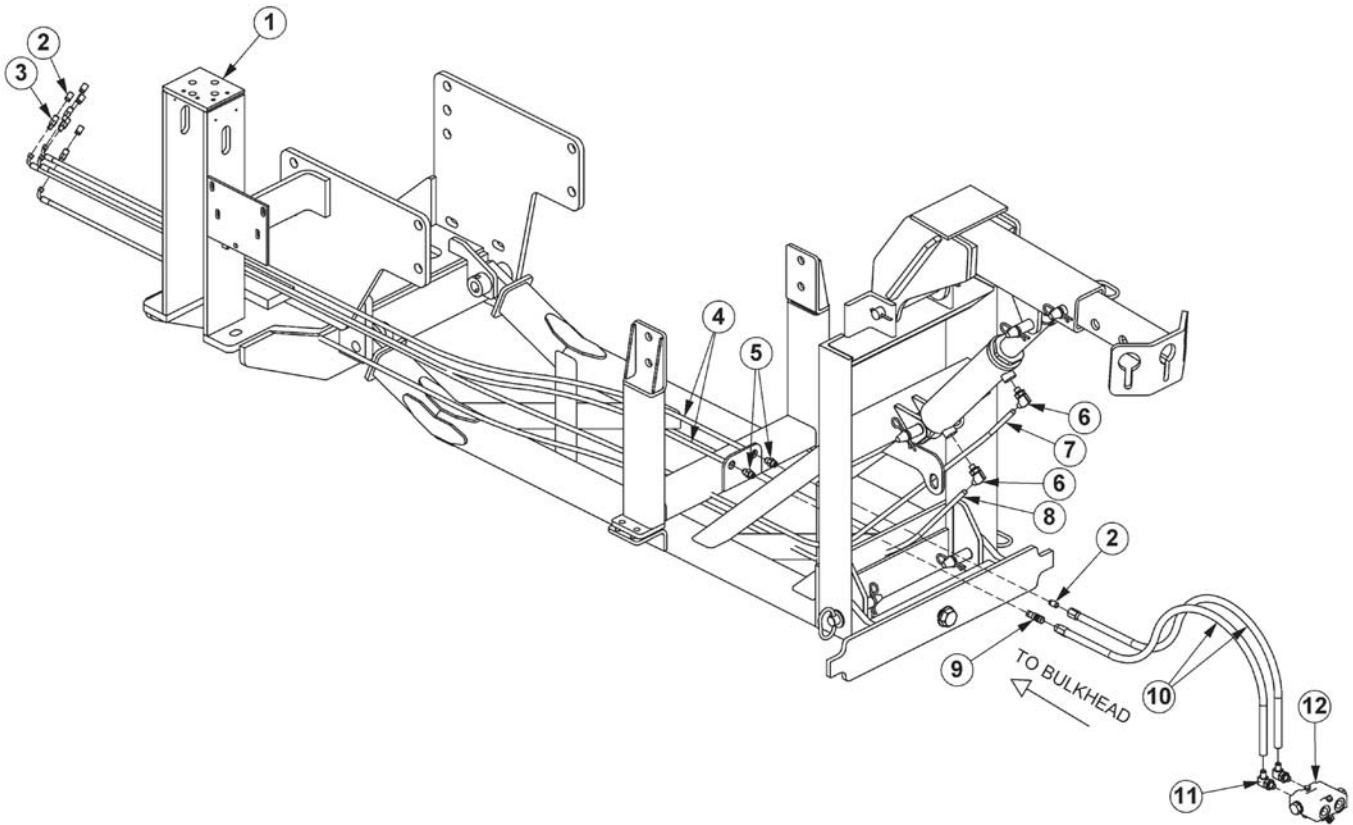

ITEM	PART NO.	QTY	DESCRIPTION
1	REF	*	MAIN FRAME
2	32900	5	QUICK CPLR,MALE,1/2 x 1/2FOR
3	33271	4	ADAPTER,1/2MOR x 3/8MJ
4	06500510	2	HOSE,1/4 x 170
5	06503147	2	FITTING,BLKHD,1/2MJ x 1/2MOR
6	33810	2	ELBOW,3/8" MJ X 1/2" MBADJ
7	06500164	1	HOSE,1/4 x 216
8	06500228	1	HOSE,1/4 x 204
9	06503148	1	QUICK CPLR,FEM,1/2 x 1/2FOR
10	REF	2	HOSE,1/2 *REFER TO FRONT PLOW ASSY
11	REF	2	ELBOW *REFER TO FRONT PLOW ASSY
12	REF	1	CUSHION VALVE *REFER TO FRONT PLOW ASSY

TRACTOR MOUNT KIT - PUMP HOSES

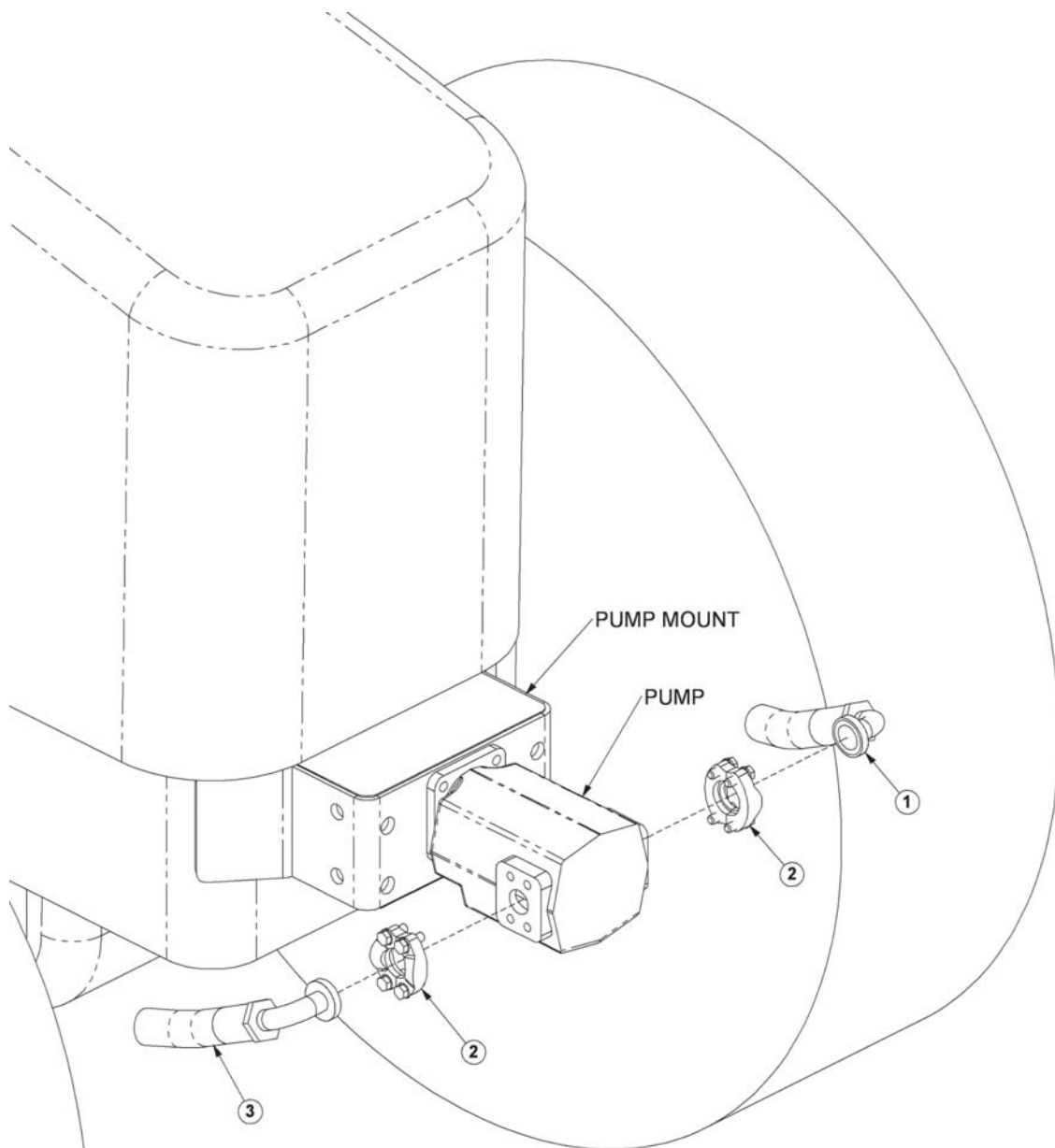

REPLACE EXISTING HOSES
IF NECESSARY

ITEM	PART NO.	QTY	DESCRIPTION
1	06500258	1	HOSE, 1-1/4 x 70 (FROM TANK TO PUMP)
2	TF4852	2	FLANGE KIT, #20
3	06500512	1	HOSE, 1 x 70 (FROM PUMP TO BRAKE VALVE)

NOTES

PAGE INTENTIONALLY
LEFT BLANK

TRACTOR MOUNT KIT - SIDE HYDRAULICS

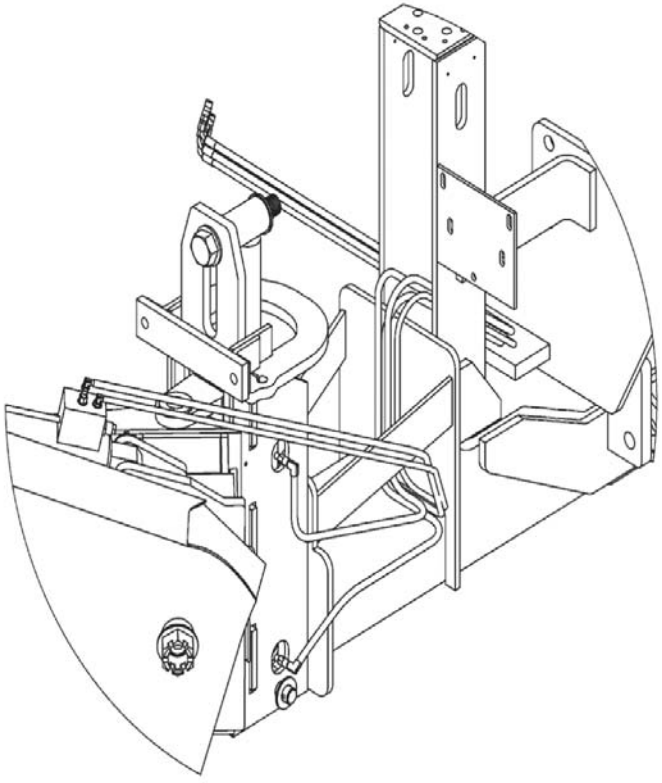
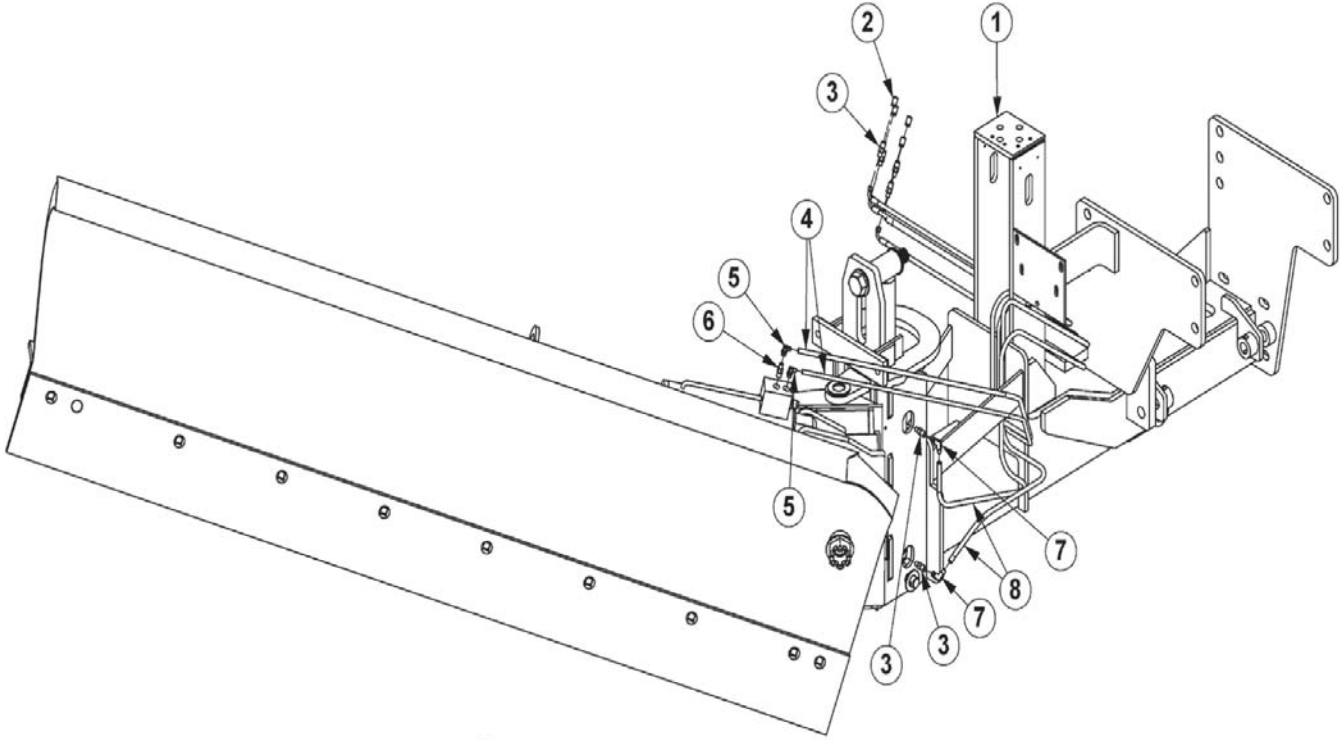

HOSE ROUTING DETAIL

TRACTOR MOUNT KIT - SIDE HYDRAULICS

ITEM	PART NO.	QTY.	DESCRIPTION
1	REF	*	MAIN FRAME
2	32900	4	QUICK CPLR,MALE,1/2 x 1/2MOR
3	33271	6	ADAPTER,1/2MOR x 3/8MJ
4	06500345	2	HOSE,1/4 x 171
5	32810	2	ELBOW,1/2ORB x 3/8MJ 90ADJ
6	34073	1	ADAPTER,1/2MOR x 1/2FOR
7	06503030	2	ELBOW,3/8MJ x 3/8MJ 90ADJ
8	06500511	2	HOSE,1/4 x 161

3-POINT STOP & PUSH ARM

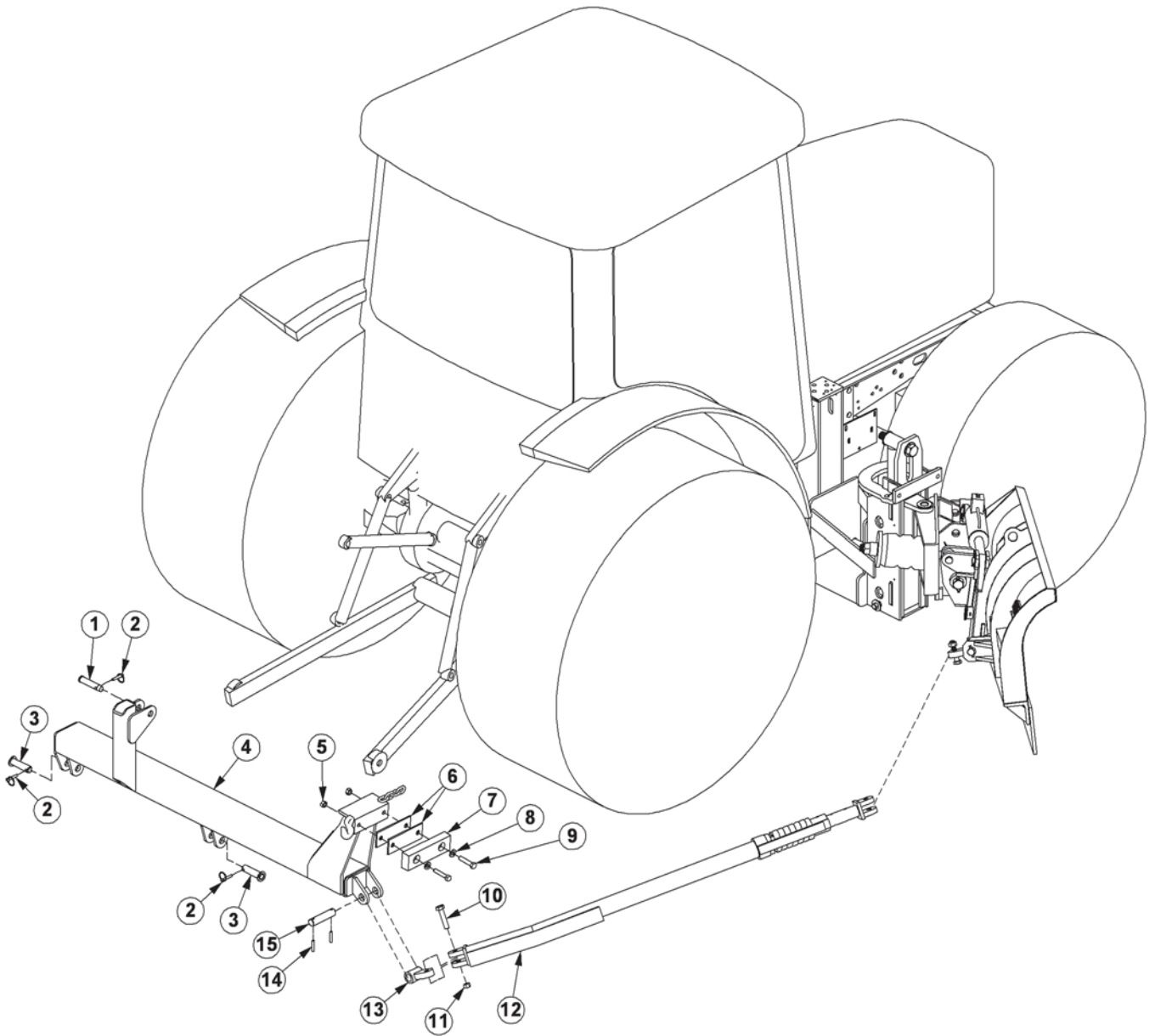

3-POINT STOP & PUSH ARM

ITEM	PART NO.	QTY.	DESCRIPTION
1	TB1036	1	PIN, TOP LINK, 3-POINT
2	TF1143	3	PIN, LYNCH, 7/16 x 2
3	TF1120	2	PIN, (CAPPED), 1-1/8 x 3-7/8
4	06300115	1	3PNT, SNWPLW
5	7030084	2	TOPLOCK NUT, 5/8
6	2100-1360	2	SPACER, 1/4 (USE AS NEEDED)
7	2300-0620	1	RUBBER STOP
8	7040006	2	FLATWASHER, 5/8, SAE
9	7020162	2	CAPSCREW, 5/8 x 3
10	7020082	1	CAPSCREW, 3/4 x 3-1/2
11	7030030	1	TOPLOCK NUT, 3/4
12	219-0632	1	PUSH BEAM ASSY
13	2100-0384	1	HINGE ASSY
14	7050028	2	ROLL PIN, 3/8 x 2
15	2100-1280	1	PIN, 1-1/4

MULTIPLIER VALVE MOUNTING

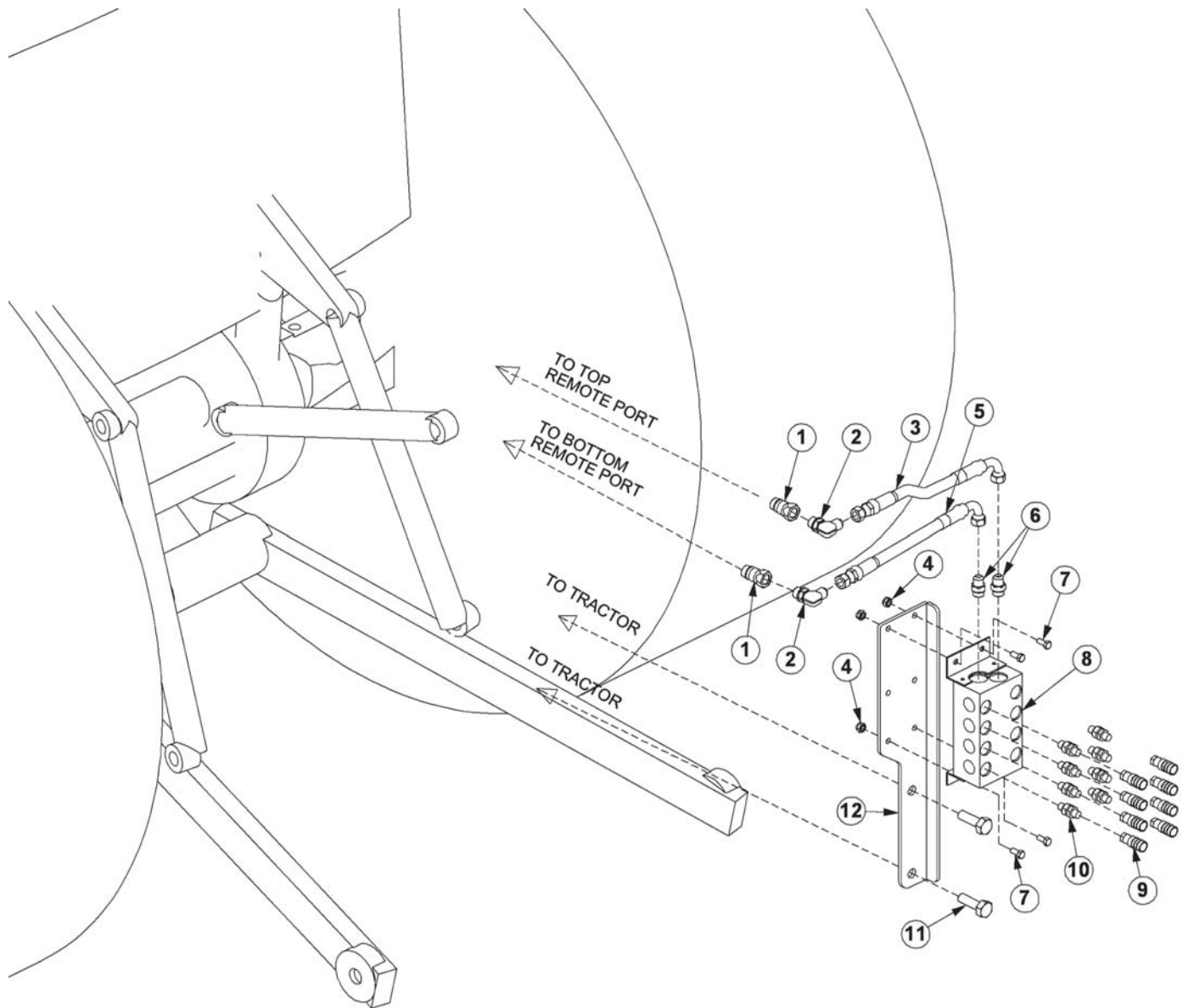

ITEM	PART NO.	QTY.	DESCRIPTION
1	32900	2	QUICK CPLR,MALE,1/2 x 1/2FOR
2	33382	2	ELBOW,1/2MOR x 1/2MJ X 90
3	06500251	1	HOSE,1/2 x 28
4	21577	4	NYLOCK NUT,5/16,NC
5	06500122	1	HOSE,1/2 x 30
6	33528	2	ADAPTER,1/2MOR x 1/2MJIC
7	21579	4	CAPSCREW,5/16 x 3/4,NC
8	06505159	1	KIT,HYD MULTIPLIER,4 FUNCTION
9	06503148	8	QUICK CPLR,FEM,1/2 x 1/2FOR
10	31329	8	ADAPTER,1/2ORB x 1/2ORBADJ
11	*	REF	TRACTOR HARDWARE
12	06411034	1	MOUNT,MULTIPLIER

3 & 4 FUNCTION MULTIPLIER VALVE BREAKDOWN

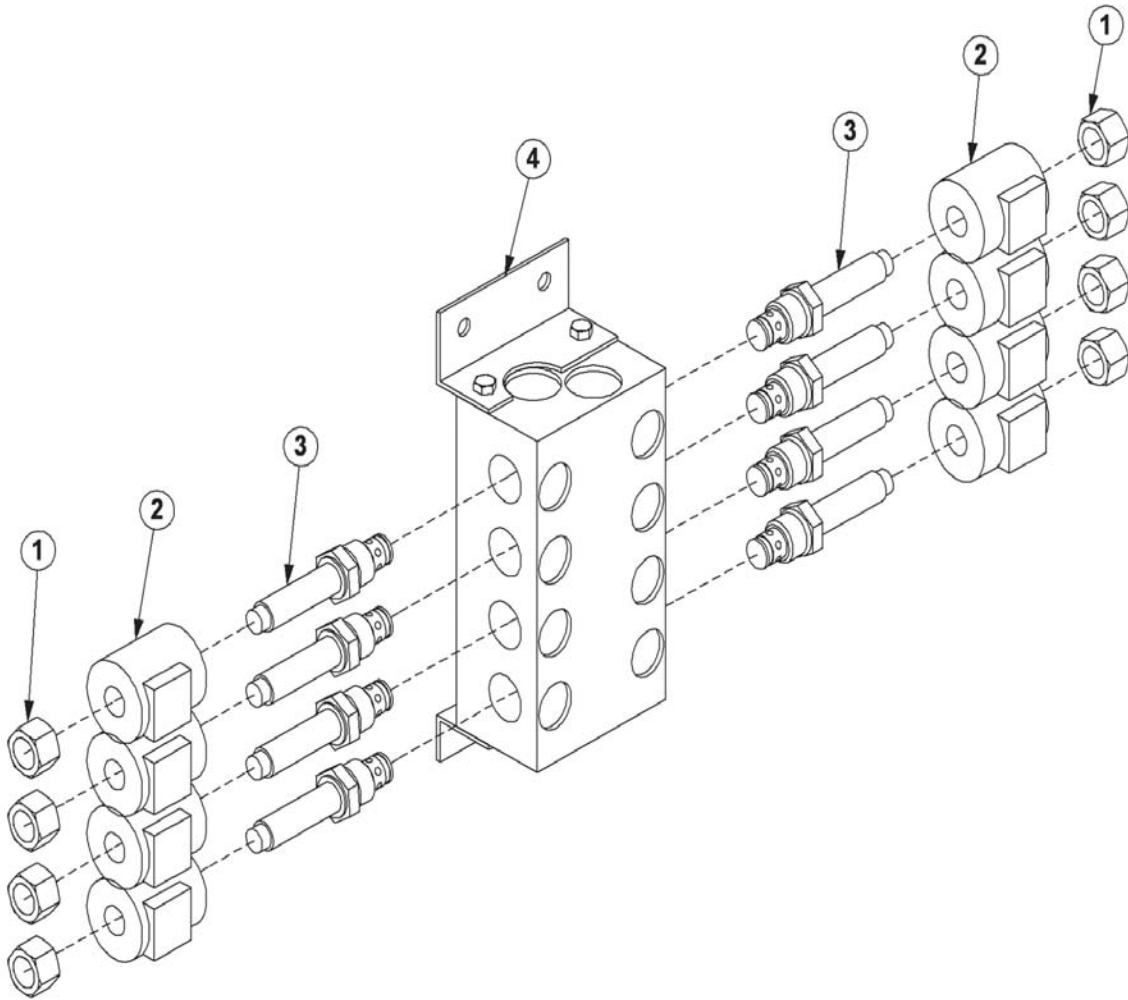

ITEM	PART NO.	QTY	DESCRIPTION
1	*	REF	SMALL NUT (NOT FOR PARTS SALE)
2	06505165	REF	SOLENOID 12V SP
3	06505164	REF	N/C CARTRIDGE (SPOOL W/SHORT NUT)
4	*	REF	MANIFOLD (NOT FOR PARTS SALE)
*	06510231	1	CONTROLLER,4 BUTTON (NOT SHOWN)
*	06505167	REF	O-RING SEAL KIT (NOT SHOWN)

2 FUNCTION MULTIPLIER VALVE BREAKDOWN

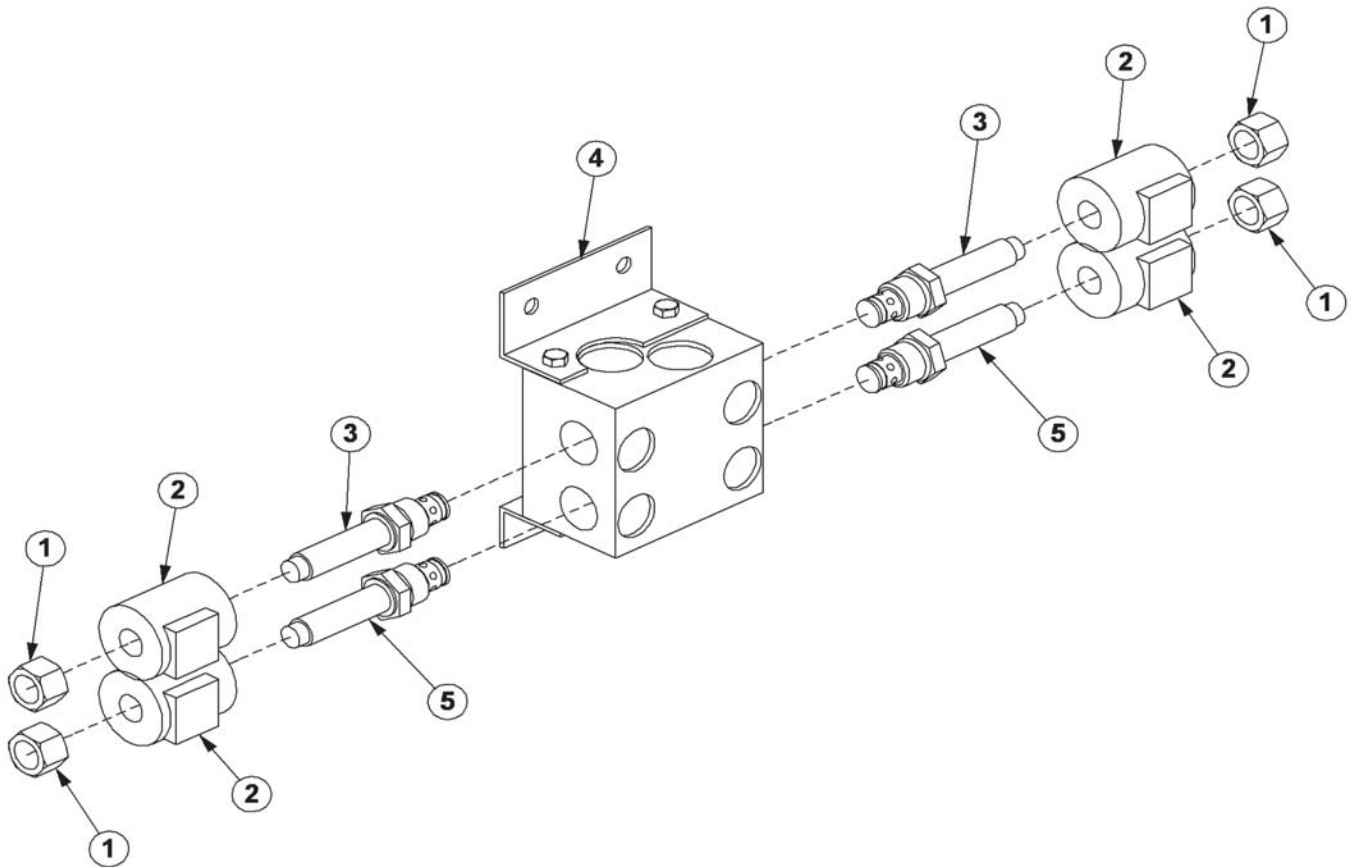

ITEM	PART NO.	QTY	DESCRIPTION
1	*	REF	SMALL NUT (NOT FOR PARTS SALE)
2	06505165	4	SOLENOID 12V SP
3	06505163	2	N/O CARTRIDGE (SPOOL W/SHORT NUT)
4	*	REF	MANIFOLD (NOT FOR PARTS SALE)
5	06505164	2	N/C CARTRIDGE (SPOOL W/SHORT NUT)
*	06510230	1	CONTROLLER, 1 BUTTON (NOT SHOWN)
*	06505167	AVAIL	O-RING SEAL KIT (NOT SHOWN)

1 FUNCTION MULTIPLIER VALVE BREAKDOWN

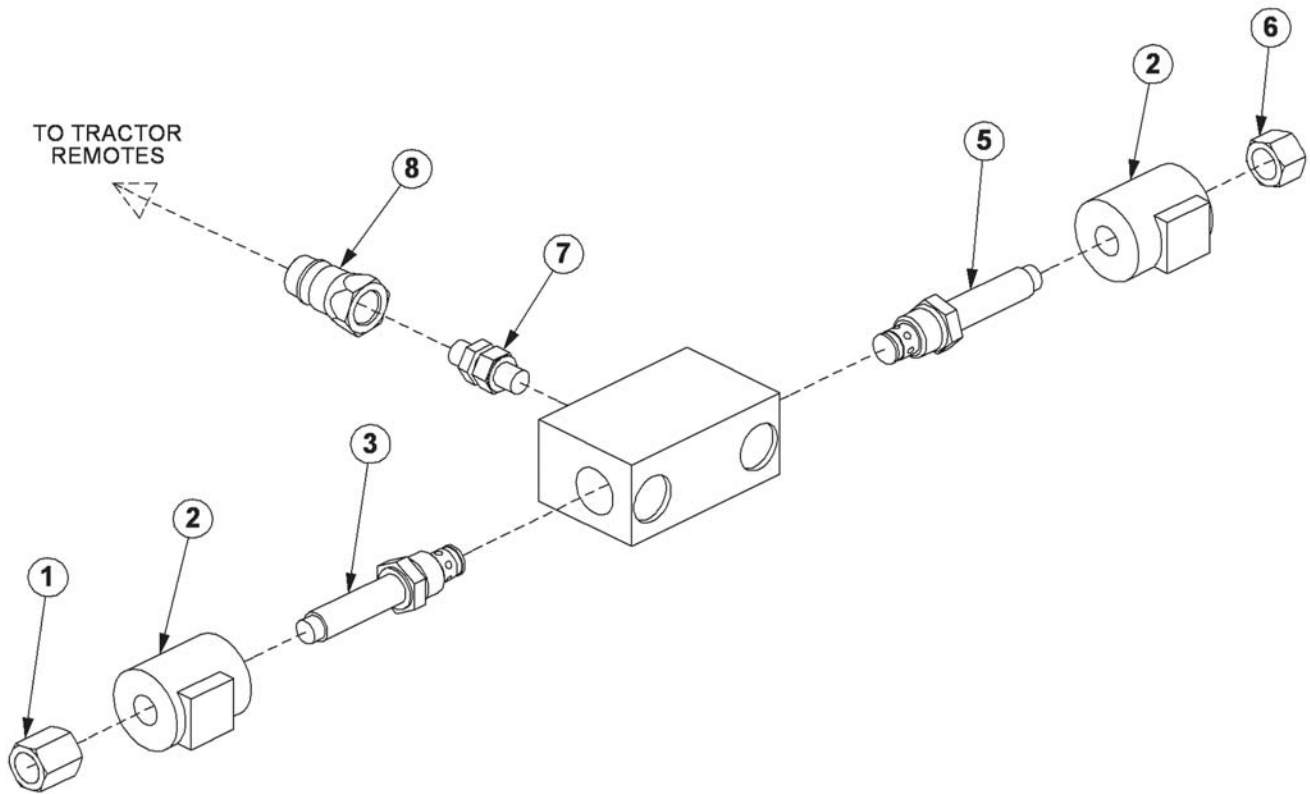

TWO REQUIRED

ITEM	PART NO.	QTY	DESCRIPTION
1	*	REF	TALL NUT (NOT FOR PARTS SALE)
2	06505162	2	SOLENOID 12V SS
3	06505161	1	N/O CARTRIDGE (POPPET W/TALL NUT)
4	*	REF	MANIFOLD (NOT FOR PARTS SALE)
5	06505160	1	N/C CARTRIDGE (SPOOL W/SHORT NUT)
6	*	REF	SHORT NUT (NOT FOR PARTS SALE)
7	31329	1	ADAPTER, 1/2ORB x 1/2ORB ADJ
8	32900	1	QUICK COUPLER, MALE 1/2 x 1/2 FOR
*	06510230	1	CONTROLLER, 1 BUTTON (NOT SHOWN)
*	06505166	AVAIL	O-RING SEAL KIT (NOT SHOWN)

SAFETY LIGHT ASSEMBLY

SAFETY LIGHT INSTALLATION

1. Install marker light assy onto the mounting bracket, running wires inside bracket tube.
2. Remove and retain panel under right rear fender that protects wiring.
3. Remove and discard back 3 screws and clips securing the right rear fender to the cab.
4. Install mtg. bracket to points in previous step with three 1/4" x 3/4"NC bolts and nylock nuts.
5. Using the mounting bracket as a template to drill two holes (13/64 dia.) and tap(1/4"NC) in the wheel well (Note: Use caution not to drill into the filter housing located behind the cab).
6. Secure bottom of mounting bracket to wheel well with two 1/4" x 3/4"NC bolts and lockwashers.
7. Next remove the top cover of the tractor cab.
8. Drill two holes 5/8" dia, one in the fender under the air duct at the right rear corner of the cab and the other at the right rear corner of the cab just inside the air duct.
9. Install grommets in the 5/8 " dia holes.
10. Route wire from mounting bracket into the area that will be covered by the panel removed in step 2, then through grommets and up into area above cab, install wires ends into connector shell and close strain relief (Note: Green wire to green wire when mated with adapter harness).
11. Splice the green wire from the adapter harness into the purple wire coming from right rear hazard light using heat shrink butt connector
12. Splice the black wire from the adapter harness into the black wire coming from right rear hazard light using heat shrink butt connector
13. Connect the adapter harness to the marker light harness.
14. Test for proper operation, the marker light should flash with hazards & right turn signal but should burn steady when left turn signal is in use.
15. Reinstall top cover of tractor cab and panel in fender to protect wiring.

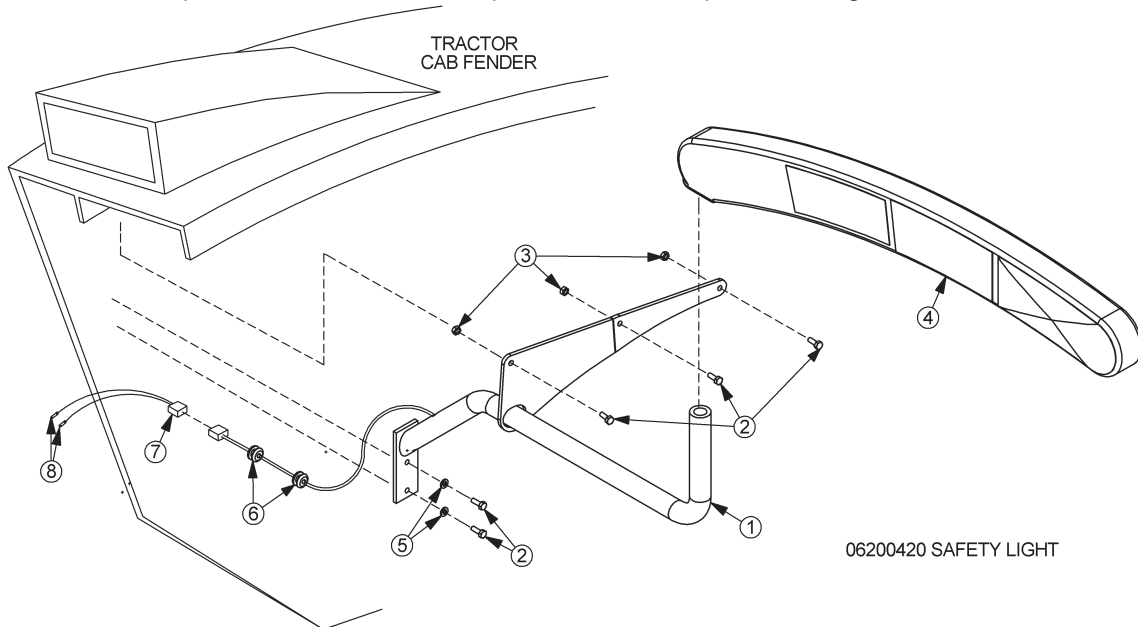

ITEM	P/N	QTY	DESCRIPTION
*	06200420	AVAIL	SAFETY LIGHT KIT (INCLUDES ITEMS 1 THRU 9)
1	34800	1	MOUNT,JD62-6420,ASAE 279.11
2	21529	5	CAPSCREW,1/4" X 3/4" NC
3	21527	3	NUT,NYLOCK,1/4" NC
4	34859	1	MARKER LIGHTASY
5	21986	2	LOCKWASHER 1/4"
6	31592	2	GROMMET, RUBBER, 5/16 X 13/16
7		1	ADAPTER HARNESS
8	35164	2	CONNECTOR, BUTT H-SHRINK
9	6T1824	2	ZIP TIE (NOT SHOWN)

**WARRANTY
SECTION**

WARRANTY INFORMATION

Tiger Corporation, 3301 N. Louise, Sioux Falls, South Dakota, warrants to the original Retail Customer, the new Tiger equipment is free of defects in material and workmanship. Any part of equipment that in Tiger's judgement, show evidence of such defects will be repaired or replaced without charge, provided that the failure of part(s) shall have occurred within twelve (12) months from the date of delivery of said equipment to the Retail Customer. Expendable components such as knives, oil, chain sprockets, skid shoes, knife mounting disks and the like are excluded but not limited to this warranty.

The Retail Customer must pay the transportation cost to and from the Tiger Dealer's service shop for warranty service. Warranty service will be performed by the Tiger Dealer from whom the equipment was purchased, during service shop regularly scheduled days and hours of operation.

All Tiger obligation under this warranty shall be terminated if the equipment is modified or altered in ways not approved in writing by Tiger, if repair parts other than genuine Tiger repair parts have been used, or if the equipment has been subject to misuse, neglect, accident, improper maintenance or improper operation.

Tiger Corporation reserves the right to make improvements in design or changes in specification at any time without incurring any obligation to owners of equipment previously sold.

No agent or person has authority to alter, add to or waive the above warranties which are agreed to be in the only warranties, representations or promises, expressed or implied, as to the quality or performance of the products covered and which do not include any implied warranty of merchantability or fitness. In no event will Tiger be liable for incidental or consequential damages or injuries, including, but not limited to, loss of profits, rental or substitute equipment or other commercial loss.

**THERE ARE NO WARRANTIES WHICH EXTEND
BEYOND THOSE EXPRESSED HEREIN.**

It is the Purchasers obligation to sign the warranty registration form **AFTER** he / she has Read and Understands the Operation and Safety Instructions stated within this manual.

ONE LAST WORD

This manual cannot possibly cover all of the potentially hazardous situations you will encounter. By being familiar with the safety rules, operating and maintenance instructions in this manual you can help prevent accidents. The objective of this manual is to help make you a better operator. Remember, **SAFETY IS YOU!**



1012

Your safety and the safety of those around you depends on **YOU**. Common sense should play a large role in the operation of this machine.

Since we at Tiger Corporation are constantly striving to improve our products, we reserve the right to change specifications or design at any time.