



# BENGAL ASSEMBLIES

RÖÎ FFEËHET DÛÁVI Ø

Ö`HΛ} óæ Á ÁCØØÏ

---

ÚCËVÙŠQÏVQ ÕÁY QP  
T UWP VQ ÕÁE ÖÁJ ÚÒÜC/VQ Õ  
Q ÛVÜWÔVQ ßÙ

---

**Tiger Corporation**  
HHEFÁ ßËŠÏ ÿ ã ^ ÁC^ È  
Ùq ÿ c ÁCæ ð ÈÜÖÁÏ Ì FËÏ  
1-800-843-6849  
1-605-336-7900  
[www.tiger-mowers.com](http://www.tiger-mowers.com)

**06011030**

# TO THE OWNER / OPERATOR / DEALER

01/11 | 1 { ^ } 0 1 2 3 4 5 6 7 8 9 10 11 12 13 14 15 16 17 18 19 20 21 22 23 24 25 26 27 28 29 30 31 32 33 34 35 36 37 38 39 40 41 42 43 44 45 46 47 48 49 50 51 52 53 54 55 56 57 58 59 60 61 62 63 64 65 66 67 68 69 70 71 72 73 74 75 76 77 78 79 80 81 82 83 84 85 86 87 88 89 90 91 92 93 94 95 96 97 98 99 100

**BEFORE YOU START!!** U 0 1 2 3 4 5 6 7 8 9 10 11 12 13 14 15 16 17 18 19 20 21 22 23 24 25 26 27 28 29 30 31 32 33 34 35 36 37 38 39 40 41 42 43 44 45 46 47 48 49 50 51 52 53 54 55 56 57 58 59 60 61 62 63 64 65 66 67 68 69 70 71 72 73 74 75 76 77 78 79 80 81 82 83 84 85 86 87 88 89 90 91 92 93 94 95 96 97 98 99 100

**READ AND UNDERSTAND THIS MANUAL! Non-English speaking operators will need to GET THE MANUAL TRANSLATED as needed!**



# DANGER

**FAILING TO FOLLOW SAFETY MESSAGES AND OPERATING INSTRUCTIONS CAN CAUSE SERIOUS BODILY INJURY OR EVEN DEATH TO OPERATOR AND OTHERS IN THE AREA.**

<p>1.</p>	<p>2. NO RIDERS. NO CHILDREN OPERATORS.</p>	<p>3. USE SAFETY SHOES, HARD HAT, SAFETY GLASSES, SEAT BELTS, ROPS &amp; OPS</p>	<p>4. BLOCK UP SECURELY BEFORE WORKING UNDER.</p>
-----------	---	--	---

- Study and understand Operator's Manuals, Safety Decals, and Instructional Decals for tractor and implement to prevent misuse, abuse, and accidents. Practice before operating in a confined area or near passersby.
  - Learn how to stop engine suddenly in an emergency. Be alert for passersby and especially children
- Allow no children on or near folding mower or tractor. Allow no riders on tractor or implement. Falling off may cause serious injury or death from being run over by tractor or mower or contact with rotating blades.
- Operate only with tractor having Roll-Over Protective Structure (ROPS) and with seat belt securely fastened to prevent injury and possible death from falling off or tractor overturn.
  - Personal Protective Equipment such as Hard Hat, Safety Glasses, Safety Shoes, & Ear Plugs are recommended.
- Block up or support raised machine and all lifted components securely before putting hands or feet under or working underneath any lifted component to prevent crushing injury or death from sudden dropping or inadvertent operation of controls. Make certain area is clear before lowering or folding
- Before transporting, put Lift Lever in detent or full-lift position. Install Transport Safety Devices securely on folding mowers. Put Booms securely in Transport Rest.
  - Folding and Boom Mowers have raised center of gravity. Slow down when turning and on hillsides.
- Make certain that SMV sign, warning lights, and reflectors are clearly visible. Follow local traffic codes.
- Never operate with Cutting Head or Folding Section raised if passersby, bystanders, or traffic are in the area to reduce possibility of injury or death from objects thrown by Blades under Guards or mower structure.
- Before dismounting, secure implement in transport position or lower to ground.
  - Put tractor in park or set brake, disengage PTO, stop engine, remove key, and wait until noise of rotation has ceased to prevent crushing by entanglement in rotating parts which could cause injury or death.
  - Never mount or dismount a moving vehicle. Crushing from rollover may cause serious injury or death.

<p>5. TRANSPORT SAFELY, LOCK UP.</p>	<p>6. USE SMV, LIGHTS, &amp; REFLECTORS.</p>	<p>7. DO NOT OPERATE WITH CUTTER OR WING RAISED.</p>	<p>8. DO NOT MOUNT OR DISMOUNT WHILE MOVING.</p>
--------------------------------------	--	--	--

**Warranty Information:** Read and understand the complete Warranty Statement found in this manual. Fill out the Warranty Registration form in full and return it within 90 days. Make certain the Serial Number of the machine is recorded on the Warranty Card, and form that you retain.



# FORWARD

This manual contains information about many features of the Tiger mowing and roadside maintenance equipment. Some of these include: Safety precautions, Assembly instructions, Operations, Maintenance and Parts. This manual will also assist you in the proper break-in, daily care, and troubleshooting of your new mower.

We recommend that you read carefully the entire manual before operating the unit. Also, time spent in becoming fully acquainted with its performance features, adjustments, and maintenance schedules will be repaid in a long and satisfactory life of the equipment.

## **Troubleshooting - Please, before you call, help us to help you!**

Please look at the equipment to observe what is happening, then:

- Classify the problem
  - Hydraulic, electrical or mechanical - Read the trouble shooting section
  - Tractor or Truck chassis - Contact vehicle dealer
  
- If unable to correct the problem yourself, contact your local Tiger Dealer after gathering:
  - Machine model \_\_\_\_\_
  - Serial number \_\_\_\_\_
  - Dealer name \_\_\_\_\_
  - Detailed information about the problem including results of troubleshooting

**Attention Owner / Operator / Dealer:** It is your obligation to read, and understand, the warranty information section located at the back of this manual denoting that the purchaser understands the safety issues relating to this machine and has received and will read a copy of this manual.

If at any time, you have a service problem with your Tiger mower, Contact your local dealer for service and parts needed.

MANUFACTURED BY:

**Tiger Corporation**

3301 N. Louise Ave.

Sioux Falls, SD 57107

1-800-843-6849

1-605-336-7900

www.tiger-mowers.com

DISTRIBUTED BY:

\_\_\_\_\_

1- \_\_\_\_\_ - \_\_\_\_\_ - \_\_\_\_\_

1- \_\_\_\_\_ - \_\_\_\_\_ - \_\_\_\_\_



# TABLE OF CONTENTS

SAFETY SECTION_____	1
ASSEMBLY / MOUNTING SECTION_____	2
OPERATION SECTION_____	3
MAINTENANCE SECTION_____	4
PARTS SECTION_____	5
COMMON PARTS SECTION_____	6
WARRANTY INFORMATION_____	7



1012

**This symbol means:**

**CAUTION – YOUR SAFETY IS AT RISK!**

When you see this symbol, read and follow the associated instructions carefully or personal injury or damage may result.

Tiger is a registered trademark.





# **SAFETY SECTION**

Safety Section 1-1

# SAFETY

## GENERAL SAFETY INSTRUCTIONS AND PRACTICES

A careful operator is the best operator. Safety is of primary importance to the manufacturer and should be to the owner/operator. Most accidents can be avoided by being aware of your equipment, your surroundings, and observing certain precautions. The first section of this manual includes a list of Safety Messages that, if followed, will help protect the operator and bystanders from injury or death. Read and understand these Safety Messages before assembling, operating or servicing this Implement. This equipment should only be operated by those persons who have read the manual, who are responsible and trained, and who know how to do so responsibly.



The Safety Alert Symbol combined with a Signal Word, as seen below, is used throughout this manual and on decals which are attached to the equipment. The Safety Alert Symbol means: "ATTENTION! BECOME ALERT! YOUR SAFETY IS INVOLVED!" The Symbol and Signal Word are intended to warn the owner/operator of impending hazards and the degree of possible injury faced when operating this equipment.

**Practice all usual and customary safe working precautions and above all--- remember safety is up to YOU. Only YOU can prevent serious injury or death from unsafe practices.**



Indicates an imminently hazardous situation that, if not avoided, WILL result in DEATH OR VERY SERIOUS INJURY.



Indicates an imminently hazardous situation that, if not avoided, COULD result in DEATH OR SERIOUS INJURY.



Indicates an imminently hazardous situation that, if not avoided, MAY result in MINOR INJURY.



Identifies special instructions or procedures that, if not strictly observed, could result in damage to, or destruction of the machine, attachments or the environment.

**NOTE:** *Identifies points of particular interest for more efficient and convenient operation or repair.*

READ, UNDERSTAND, and FOLLOW the following Safety Messages. Serious injury or death may occur unless care is taken to follow the warnings and instructions stated in this Manual and in the Safety Messages on the implement. Always follow the instruction in this manual and use good common sense to avoid hazards.



**NOTE:** *If you want a translation of this safety section in one of the following Languages, please contact: Translations at 1502 E. Walnut Street Seguin, TX 78155; Fax: (830) 372-9529; Safety Section Translations are available in Spanish, Portuguese, French, German, Russian. PN GS01*



# SAFETY

**SAFETY**

## Operator Safety

				
Read and understand Operator's Manual	Always wear Safety Glasses	Wear Hard Hat Safety Shoes	Never use Drugs or Alcohol when operating equipment	Wear Safety Vest when operating on or near roads

**⚠ WARNING**

**TO AVOID SERIOUS INJURY OR DEATH DO THE FOLLOWING:**

- **READ, UNDERSTAND** and **FOLLOW** Operator's Manual instructions, Warnings and Safety Messages.
- **WEAR SAFETY GLASSES**, safety shoes, hard hat, hearing protection and gloves when operating or repairing equipment
- **WEAR** appropriate breathing respirator when operating in dusty conditions to avoid respiratory diseases.
- **DO NOT WEAR** loose clothing or jewelry to avoid rotating parts entanglement injury.
- **DO NOT USE DRUGS** or **ALCOHOL** before or while operating equipment.
- **DO NOT ALLOW** anyone to operate equipment under the influence of drug or alcohol.
- **CONSULT** medical professional for medication impairment side effects.
- **STAY CLEAR** of hot surfaces such as Mufflers, hydraulic pumps, valves and tanks.
- **STAY ALERT**, prolonged operation can cause fatigue, **STOP** and **REST**.

**GENERAL OPERATING SAFETY**

**VISIBILITY CONDITIONS WHEN MOWING:**

- **OPERATE IN DAYLIGHT** or with lights that gives at least 100 yards clear visibility.
- **BE ABLE TO SEE** and identify passersby, steep slopes, ditches, drop-offs, overhead obstructions, power lines, debris and foreign objects.
- Avoid backing up while mowing, vision may be limited, severe damage or injury can occur.
- **DO NOT** run tractor in enclosed building without adequate exhaust ventilation.

**GROUND SPEED WHEN MOWING:**

- **NORMAL SPEED** range is between 1 to 2 mph(1-3 kph).
- **ADJUST MOWING SPEED** for terrain conditions and grass type, density and cut height.
- **REDUCE MOWING SPEED** when near steep slopes, ditches, drop-offs, overhead obstructions, power lines and to avoid debris and foreign objects.

**TRACTOR and MOWER**

- **DO NOT** operate the tractor or mower unless the equipment is maintained and operating properly.
- **DISCONTINUE OPERATION** if tractor or mower electrical and hydraulic controls do no function properly.
- **DISCONTINUE OPERATION** of the tractor if the braking or steering systems do not function properly.
- **DO NOT** operate the tractor or mower if there are any hydraulic leaks.

**INSECT INFESTATION**

- **DO NOT** operate in areas where bees or insects may attack unless you **WEAR PROTECTIVE CLOTHING** or use enclosed tractor cab.

**PTO SPEED:**





- **DO NOT EXCEED IMPLEMENT RATED PTO SPEED**
- **AVOID** exceeding rated PTO speeds that may result in broken drivelines or blade failures.

**SAFETY SIGNS:**

- **REPLACE** missing, damaged or unreadable safety signs immediately. **PN OSBM-01**

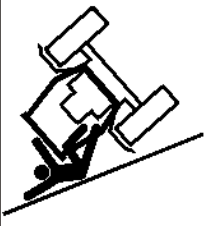
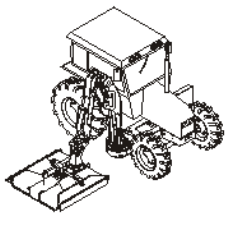
# SAFETY

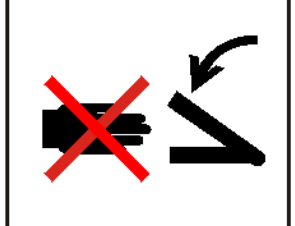
## CRUSHING HAZARDS

				
Crushing injury from roll over	Use Cab Tractor With Boom Mowers	Always wear seatbelt	Pinch Point Hazard Keep Hands and body parts clear of pinch points	Crushing injury from boom or mower head falling



**TO AVOID SERIOUS INJURY OR DEATH FROM FALLING OFF TRACTOR, EQUIPMENT RUN OVER, ROLLOVER AND CRUSHING BY FALLING WING OR IMPLEMENT:**

- **USE ROPS** and **SEAT BELT** equipped tractors for mowing operations.
- **KEEP ROPS** lock in up position.
- **ALWAYS BUCKLE UP** seat belt when operating tractor and equipment.
- **ONLY OPERATE** tractor and equipment while seated in tractor seat.

### **WHEN RAISING BOOM MOWER:**

- Raise or lower **ONLY WHILE SEATED** in tractor seat with seat belt buckled.
- **KEEP BYSTANDERS CLEAR** of area **TO AVOID** crushing.
- **KEEP** sufficient clearance around implement and wings **TO AVOID** contacting buildings or overhead power lines.

**LIFTED Equipment can fall from mechanical or hydraulic failure or inadvertent Control Lever movement.**



**TO AVOID EQUIPMENT FALLING while working near or under lifted boom, components and Mower Head:**

- **SECURELY SUPPORT** or **block up** raised equipment, wings and components.
- **BLOCK UP** and **securely support** equipment before putting hands, feet or body under raised equipment or lifted components.
- **KEEP BYSTANDERS CLEAR** of raised boom or mower head until **securely blocked up**.

### **WHEN PARKING** Implement and Tractor:

- **LOWER** Mower Head to the ground or **BLOCK** lifted parts before leaving equipment.
- **NEVER** leave implement unattended in a raised position.







**TO AVOID CHILDREN FALLING OFF OR BEING CRUSHED BY EQUIPMENT:**

- **NEVER ALLOW** children to play on or around Tractor or Implement.
- **DO NOT** operate without operator CAB or OVERHEAD protection. Falling limbs and debris can cause injuries. *PN CHBM-01*

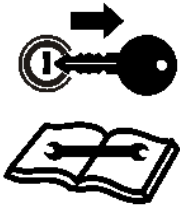
# SAFETY

## CONNECTING OR DISCONNECTING IMPLEMENT SAFETY

			
<p>Stop Tractor Remove Key Read Manual</p>	<p>Crushing Hazard Do Not get under boom when connecting mower head to boom</p>	<p>Stability Hazard Ensure 20% of tractor weight is on front wheels</p>	<p>Stability Hazard Ensure 1500lbs down force on left tire with boom extended</p>



**TO AVOID SERIOUS INJURY OR DEATH FROM BEING CRUSHED BY TRACTOR OR IMPLEMENT:**

### WHEN connecting mower head to the boom:

- **KEEP BYSTANDERS AWAY** from tractor and mower.
- Ensure there is enough room to lift and swing the boom with out hitting objects

### BEFORE connecting and disconnecting the mower head or boom:

- **STOP TRACTOR ENGINE**, place transmission into park, engage parking brake and remove key.

### WHEN connecting and disconnecting the mower head or boom:

- **DO NOT** crawl or walk under raised mower head or boom. (*Refer to Instructions in Operation Section*)

### WHEN CONNECTING IMPLEMENT DRIVELINE:(If equipped)

#### TO AVOID implement driveline coming loose during operation:

- **LUBRICATE** yoke spring locking collar to ensure it freely slides on PTO shaft.
- **SECURELY** seat yoke locking balls in PTO shaft groove.
- **PUSH** and **PULL DRIVELINE** on both the tractor and implement **PTO SHAFTS** to ensure it is **SECURELY ATTACHED**.

#### TO AVOID broken driveline during operations:

- **CHECK** driveline for proper length between PTO shaft and implement gearbox shaft. (*Refer to Instructions in Operation Section*)
- Drivelines too short can pull apart or disengage.
- Drivelines too long can bottom out.
- Bottoming driveline telescoping assembly will stop sliding and become solid.
- Driveline bottoming can push through support bearings and break off PTO shaft.





#### CONTACT DEALER if implement driveline does not match Tractor PTO shaft:

- **DO NOT USE PTO ADAPTER.**  
Using a PTO adapter can cause:
  - Excessive vibration, thrown objects, blade and implement failures by doubling operating speed.
  - Increased working length exposing unshielded driveline areas and entanglement hazards. *PN CDBM-01*

**SAFETY**

# SAFETY

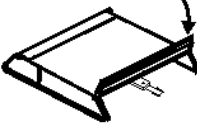
## THROWN OBJECTS HAZARDS

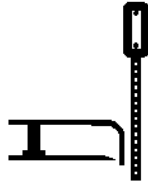
				
Mower Thrown Objects Hazard	Raised Mower Thrown Objects	Keep mower door closed when traffic comes within 300 feet	Inspect Area remove foreign objects	Do not let blades contact solid objects



**ROTARY MOWERS CAN THROW OBJECTS 300 FEET OR MORE UNDER ADVERSE CONDITIONS.**

### TO AVOID SERIOUS INJURY OR DEATH TO OPERATOR OR BYSTANDERS FROM THROWN OBJECTS:

- KEEP bystanders 300 feet away

### STOP MOWING IF PASSERSBY ARE WITHIN 300 FEET UNLESS:

- **ALL THROWN OBJECT SHIELDING** including, Front and Rear Deflectors, Chains Guards, Steel Guards, Bands, Side Skirts and Skid Shoes in place and in good condition when mowing.
- Mower is close and parallel to ground without exposing blades.
- **MOWING AREA** has been inspected and foreign materials and debris have been removed.
- **DO NOT** shred or mow loose or previously cut material if **BYSTANDERS** are within 300 feet.
- **PASSERSBY** are inside enclosed vehicle.

### INSPECT AREA FOR POTENTIAL THROWN OBJECTS BEFORE MOWING:

- **REMOVE** debris, rocks, wire, cable, metal objects and other foreign material from area.  
Wire, cable, rope, chains and metal objects can be thrown or swing outside deck with great velocity:
  1. **MARK** objects that cannot removed.
  2. **AVOID** these objects when mowing.

### HIGH GRASS and WEED AREA INSPECTION:

- **INSPECT** for and **REMOVE** any hidden large debris.
- **MOW** at Intermediate height
- **INSPECT** and remove remaining debris
- **MOW** at final height.

### MOWER THROWN OBJECT SHIELDING:

- **KEEP** all thrown object shielding including, Front and Rear Deflectors, Chains Guards, Steel Guards, Bands, Side Skirts and Skid Shoes in place and in good condition when mowing.
- **DO NOT OPERATE** with any thrown object shielding missing, damaged or removed.





### RIGHT OF WAY (Highway) MOWING

- Stop mowing if any bystander comes within 300 feet of the mower.
- No shielding is 100% effective in preventing thrown objects. To Reduce Possibility of Injury:
  1. **MAINTAIN MOWER SHIELDING**, side skirts, skid shoes, and blades in good operational condition,
  2. **RAISE CUTTING HEIGHT** to **6 INCHES** minimum,
  3. **INSPECT AREA** thoroughly before mowing to **REMOVE** potential **THROWN OBJECT HAZARDS**,
  4. **NEVER ALLOW BLADES** to **CONTACT SOLID OBJECTS** like wire, rocks, post, curbs, guardrails, or ground while mowing. *PN TOBM-01*

# SAFETY

SAFETY

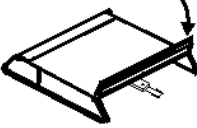
## THROWN OBJECTS HAZARDS (Continued)

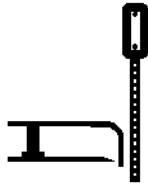
				
Mower Thrown Objects Hazard	Raised Mower Thrown Objects	Keep mower door closed when traffic comes within 300 feet	Inspect Area remove foreign objects	Do not let blades contact solid objects

### MOWER OPERATION:

- **DO NOT** exceed mower's rated Cutting Capacity or cut non-vegetative material.
- **USE ENCLOSED TRACTOR CABS** when two or more mowers are operating in mowing area.
- Do Not mow in areas where bees or insects may attack unless you **WEAR PROTECTIVE CLOTHING** or use enclosed tractor cab.
- **ADJUST** mower head close and parallel to ground without exposing blades.
- **ADJUST** cutting **HEIGHT** to **AVOID BLADE CONTACT** with solid objects like wire, rocks, posts, curbs, guard rails and fixed obstructions.
- **CLOSE** Mower door and stop operating if bystanders come within 300 feet of the mower.
- Keep mower door closed when cutting close to the ground.
- Open door only to cut large brush or tree limbs. Close door immediately after cutting limb.
- **DO NOT** push mower head down onto material to cut it, use the front tips of the mower blades to cut into the material.
- **DO NOT** operate mower when mower is in transport position.
- **STOP MOWING** immediately if blades strike heavy objects, fixed structures, metal guard rails and concrete structures:
  1. **BLADES CAN FAIL** from impact and objects can be thrown with great velocity.
  2. **INSPECT** and **REPLACE** any damaged blades.
  3. **CHECK** blade carrier and **REPLACE** if damaged.
- **DO NOT** mow in standing water **TO AVOID** possible **BLADE FAILURE**.
- **AVOID MOWING** in reverse:
  1. **STOP PTO** and back up mower.
  2. **LOWER** mower, engage **PTO** and mow forward.
- **DISENGAGE** mower head and wait until **BLADES** stop rotating before raising mower to transport position.
- **DO NOT ENGAGE PTO** with mower in transport position.
- **STOP** mowing when **EXCESSIVE VIBRATION** occurs:
  1. **STOP PTO** and tractor **ENGINE**.
  2. **INSPECT** mower for vibration source.
  3. **REPLACE** any damage parts and bent or damaged **BLADES**. *PN TOBM-02*

# SAFETY

## RUN OVER HAZARDS

		
Operator run over hazard	Rider fall off run over hazard	Bystander run over hazard



**TO AVOID SERIOUS INJURY OR DEATH FROM FALLING OFF TRACTOR OR EQUIPMENT RUN OVER:**

- **USE ROPS** and **SEAT BELT** equipped tractors for mowing operations.
- **KEEP ROPS** locked in **UP** position.
- **ONLY** start tractor while seated in tractor seat.
- **ALWAYS BUCKLE UP** seat belt when operating tractor and equipment.
- **ONLY OPERATE** tractor and equipment while seated in tractor seat.
- **NEVER ALLOW RIDERS** on tractor or implement.
- When not mowing stow Boom and Mower head in transport location before moving.

### **WHEN MOUNTING AND DISMOUNTING TRACTOR:**

- **ONLY** mount or dismount when tractor and moving parts are stopped.
- **STOP ENGINE AND PTO**, engage parking brake, lower implement, allow all moving parts to stop and remove key before dismounting from tractor. *PN ROBM-01*



# SAFETY

SAFETY

## PTO ENTANGLEMENT HAZARDS

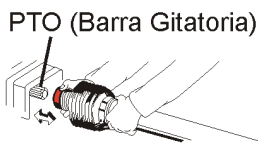
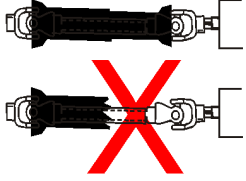
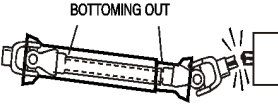
	 <p>PTO (Barra Gitoria)</p>		 <p>BOTTOMING OUT</p>
<p>Entanglement hazard Do Not approach or touch a rotating PTO driveshaft</p>	<p>Make sure PTO shaft is securely attached Do Not Use PTO Adapter</p>	<p>DO NOT Operate if PTO shields are damaged or missing</p>	<p>Make sure PTO shafts are proper length</p>



**KEEP AWAY FROM ROTATING DRIVELINES AND ELEMENTS TO AVOID SERIOUS INJURY OR DEATH:**

**STAY AWAY** and **KEEP** hands, feet and body **AWAY** from rotating blades, drivelines and parts until all moving elements have stopped.

- **STOP, LOOK** and **LISTEN** before approaching the mower to make sure all rotating motion has stopped.
- **ROTATING COMPONENTS CONTINUE** to **ROTATE** after the PTO is shut off.

### PTO SHIELDING:

#### TO AVOID SERIOUS INJURY OR DEATH FROM ENTANGLEMENT WHEN OPERATING IMPLEMENT:

- **KEEP PTO** shields, integral driveline shields and input shields installed
- **DO NOT OPERATE** mower without shields and guards in place or missing
- **REPAIR OR REPLACE** if damage, broken or missing
- **ALWAYS REPLACE GUARDS** that have been removed for service or maintenance.
- Do Not use PTO or PTO guard as a step.

#### TO AVOID broken driveline during operations:

- **CHECK** driveline for proper length between PTO shaft and implement gearbox shaft. *(Refer to Instructions in Operation Section)*
- Drivelines too short can pull apart or disengage.
- Drivelines too long can bottom out.  
Bottoming driveline telescoping assembly will stop sliding and become solid.
- Driveline bottoming can push through support bearings and break off PTO shaft
- **AVOID** sharp turns or lift mower to heights to cause driveline "knocking".
- Lubricate driveshaft-telescoping components weekly.





#### CONTACT DEALER if implement driveline does not match Tractor PTO shaft:

- **DO NOT USE PTO ADAPTER.**

Using a PTO adapter can cause excessive vibration, thrown objects, blade and implement failures by doubling operating speed. Increased working length exposing unshielded driveline areas. **PN PE01**

# SAFETY

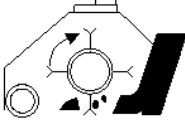
## MOWER BLADE CONTACT HAZARDS

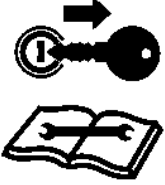
					
Do not put fingers underneath mower	Do not put hands underneath Flail Mower	Do not put foot underneath mower	Do not put foot underneath Flail Mower	Shearing Hazard from Sickle blades	Stop Tractor Remove Key Read Manual



**KEEP AWAY FROM ROTATING BLADES TO AVOID SERIOUS INJURY OR DEATH FROM BLADE CONTACT:**

- **STAY AWAY** and **KEEP HANDS, FEET** and **BODY AWAY** from rotating blades, drivelines and parts until all moving elements have stopped.
- **DO NOT** put hands or feet under mower decks
- **STOP** rotating **BLADES** disengage mower switch and PTO and wait for blade to stop rotating before raising mower head.
- **DO NOT** approach Sickle Bar head until Tractor Engine has been shut off.
- **STOP LOOK** and **LISTEN** before approaching the mower to make sure all rotating motion has stopped. *PN MBBM-01*

SAFETY

# SAFETY

## HIGH PRESSURE OIL LEAK HAZARD

			
<p>High pressure oil penetrating skin</p>	<p>High pressure oil eroding skin</p>	<p>Using cardboard to check for oil leaks</p>	<p>Tank contents under pressure. Allow oil to cool before slowly removing cap</p>



**TO AVOID SERIOUS INJURY OR DEATH FROM HIGH PRESSURE HYDRAULIC OIL LEAKS PENERATING SKIN:**

- **DO NOT OPERATE** equipment with oil or fuel leaks.
- **KEEP** all hydraulic hoses, lines and connections in **GOOD CONDITION** and **TIGHT** before applying system pressure.
- **RELIEVE HYDRAULIC PRESSURE** before disconnecting lines or working on the system.
- **REMOVE** and replace hose if you suspect it leaks. Have dealer test it for leaks.

**HIGH PRESSURE FLUID LEAKS CAN BE INVISIBLE.**

**WHEN CHECKING FOR HYDRAULIC LEAKS AND WORKING AROUND HYDRAULIC SYSTEMS:**

- **ALWAYS WEAR** safety glasses and impenetrable gloves.
- **USE** paper or cardboard to search for leaks.
- **DO NOT USE** hands or body parts to search for leak.
- **KEEP** hands and body **AWAY** from pin holes and nozzles ejecting hydraulic fluid.
- Hydraulic fluid may cause gangrene if not surgically removed immediately by a doctor familiar with this form of injury.

**Use caution when removing Hydraulic Tank cap.**

- Tank contents maybe under pressure
- Allow oil to cool before removing cap.
- Relieve oil pressure before removing cap slowly.
- Stay away from hot oil that may spray from tank.

*PN HPBM-01*

**SAFETY**

# SAFETY

## ELECTRICAL & FIRE HAZARDS

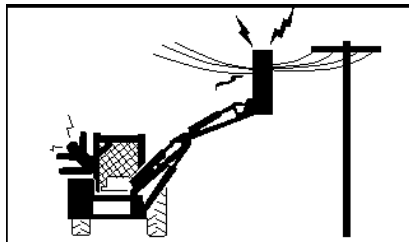

Mower head or Boom contacting overhead electrical lines



Strike and explosion Hazard  
Blades Contacting Utility or Gas Lines

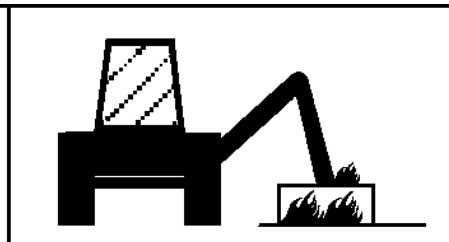

Fire Hazard Do Not operate near fires. Keep debris away from hydraulic pumps and valves



**TO AVOID SERIOUS INJURY OR DEATH FROM ELECTRICAL CONTACT WHEN WORKING AROUND ELECTRICAL POWER LINES, GAS LINES AND UTILITY LINES:**

- **INSPECT** mowing area for overhead or underground electrical power lines, obstructions, gas lines, cables and Utility, Municipal, or other type structure.
- **KEEP** all raised wings at a 10 feet or greater distance from all power lines and overhead obstructions.
- **DO NOT** allow mower to contact with any Utility, Municipal, or type of structures and obstructions.
- **CALL 811** and 1-800-258-0808 for identify buried utility lines.

**FIRE PREVENTION GUIDELINES while Operating, Servicing, and Repairing Mower and Tractor to reduce equipment and grass fire Risk:**

- **EQUIP** Tractor with a **FIRE EXTINGUISHER**
- **DO NOT OPERATE** mower on a tractor equipped with under frame exhaust
- **DO NOT SMOKE** or have open flame near Mower or Tractor
- **DO NOT DRIVE** into burning debris or freshly burnt area
- **AVOID FIRE IGNITION** by not allowing mower blade to contact solid objects like metal or rock.
- **DO NOT** operate if oil is leaking. Repair oil leak and remove all accumulated oil before operating.
- **CLEAR** any grass clippings or debris buildup around mower hydraulic pumps, valves or tanks.
- **SHUT OFF ENGINE** while refueling. *PN EFBM-01*

# SAFETY

## TRANSPORTING HAZARDS

		
<p>Use SMV signs and Flashing Lights</p>	<p>Loss of Control Stopping Hazard</p>	<p>Loss of Control Speeding Hazard</p>

### **WARNING**

TO AVOID SERIOUS INJURY AND DEATH WHEN TOWING OR TRANSPORTING EQUIPMENT:

- **KEEP** transport speed **BELOW** 20 mph to maintain control of equipment.
- **REDUCE SPEED** on inclines, on turns and in poor towing conditions.
- **DO NOT TOW** with trucks or other vehicles.
- **USE** only properly sized and equipped tractor for towing equipment.
- **FOLLOW** all local traffic regulations.

#### **TRACTOR REQUIREMENTS FOR TOWING OR TRANSPORTING IMPLEMENTS:**

- **ONLY TRANSPORT** with tractor with **ROPS** in the raised position.
- **USE** properly sized and equipped tractor that exceeds implement weight by at least 20%.
- **KEEP** 20% of tractor weight on front wheels to maintain safe steering.

#### **BEFORE TRANSPORTING OR TOWING IMPLEMENT:**

##### **TRACTOR INSPECTION:**

- **CHECK** steering and braking for proper operation and in good condition.
- **CHECK SMV** sign, reflectors and warning lights for proper operation and visibility behind unit.
- **CHECK** that your driving vision is not impaired by tractor, cab, or implement while seated in tractor seat.
- **ADJUST** your operating position, mirrors, and implement transport for clear vision for traveling and traffic conditions.

#### **PREPARE IMPLEMENT FOR TRANSPORTING OR TOWING:**

- Store Boom and Mower in transport positions and engage transport locks if equipped.

#### **DETERMINE STOPPING CHARACTERISTICS OF TRACTOR AND IMPLEMENT FOR TRANSPORTING OR TOWING:**

##### **BRAKING TESTS:**

- Stopping distance with implement attached may increase
- Observe **STOPPING** distances increases with increased speeds.
- **DETERMINE** the maximum safe transport speed that does not exceed 20 mph.
- Reduce travel speed in wet or icy roads, stopping distances increase.

#### **DETERMINE MAXIMUM TURNING SPEED BEFORE OPERATING ON ROADS OR UNEVEN GROUND:**

- **TEST** equipment in slowly increasing speed in turns to determine it can be operated at higher speeds.
- **USE REDUCED** turning speeds in sharp turns to avoid equipment turning over.

#### **WHEN TOWING OR TRANSPORTING EQUIPMENT:**





- Always **WEAR SEAT BELT** when operating or transporting mower.
- **USE** low speeds to avoid overturn with raised wings.
- **USE** low speeds and gradual steering on curves, hills, rough or uneven surfaces and on wet roads.
- **TURN ON** tractor **FLASHING WARNING LIGHTS**.
- **ALLOW** clearance for implement swing while turning.

**KEEP** raised boom mower 10 feet or greater distance from all power lines and overhead obstructions. *PN THBM-01*

**SAFETY**

# SAFETY

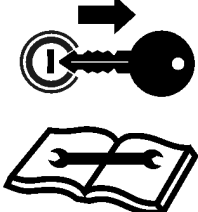
## HAZARDS WITH MAINTENANCE OF IMPLEMENT

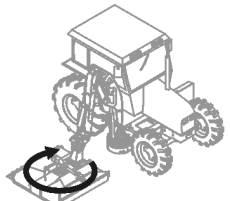
				
Periodically inspect all moving parts, lubricate drivelines, and tighten all fasteners	Lower mower head to ground or block up before servicing	Stop engine remove key before conducting maintenance	Set mower head securely on the ground before servicing blades	Thrown Objects Hazard Ensure blades rotate clockwise viewed from above mower head



**AVOID SERIOUS INJURY OR DEATH FROM COMPONENT FAILURE BY KEEPING IMPLEMENT IN GOOD OPERATING CONDITION IN PERFORMING PROPER SERVICE, REPAIRS AND MAINTENANCE.**

### BEFORE PERFORMING SERVICE, REPAIRS AND MAINTENANCE ON THE IMPLEMENT:

- **STOP ENGINE AND PTO**, engage parking brake, lower implement, allow all moving parts to stop and remove key before dismounting from tractor.
- **PLACE** implement on ground or securely block up raised equipment. Use large blocks on soft or wet soil.
- **PUSH** and **PULL** Remote Hydraulic Cylinder lever to relieve hydraulic pressure.
- **DISCONNECT Pump solenoid valve or PTO driveline connection before servicing mower head.**
- **WEAR SAFETY GLASSES, PROTECTIVE GLOVES** and follow **SAFETY PROCEDURES** when performing service, repairs and maintenance on the implement:
  - Always **WEAR** protective **GLOVES** when handling blades, knives, cutting edges or worn component with sharp edges.
  - Always **WEAR GLOVES** and **SAFETY GLASSES** when servicing hot components
  - **AVOID CONTACT** with hot hydraulic oil tanks, pumps, motors, valves and hose connection surfaces.
  - **SECURELY** support or **BLOCK UP** raised implement, framework and lifted components before working underneath equipment.
  - **FOLLOW INSTRUCTIONS** in maintenance section when replacing hydraulic cylinders to prevent component falling.
  - **STOP** any implement movements and **SHUT-OFF TRACTOR** engine before doing any work procedures.
  - **USE** ladder or raised stands to reach high equipment areas inaccessible from ground.
  - **ENSURE** good footing by standing on solid flat surfaces when getting on implement to perform work.
  - **FOLLOW** manufacturer's instructions in handling oils, solvents, cleansers, and other chemical agents.
  - **DO NOT** change any factory-set hydraulic calibrations to avoid component or equipment failures.
  - **DO NOT** modify or alter implement, functions or components.
  - **DO NOT WELD** or repair rotating mower components. These may cause vibrations and component failures being thrown from mower.

### PERFORM SERVICE, REPAIRS, LUBRICATION AND MAINTENANCE OUTLINED IN IMPLEMENT MAINTENANCE SECTION:

- **INSPECT** for loose fasteners, worn or broken parts, leaky or loose fittings, missing or broken cotter keys and washers on pins, and all moving parts for wear.
- **REPLACE** any worn or broken parts with authorized service parts.
- Inspect mower blade spindle to ensure bearing preload. If loose repair before operating.
- **LUBRICATE** unit as specified by lubrication schedule
- **NEVER** lubricate, adjust or remove material while it is running or in motion.
- **TORQUE** all bolts and nuts as specified.

### BLADE INSPECTION:

- Inspect blade carrier and blades daily.
- Check blade and blade carrier **BOLT TORQUE** daily. Loose bolts can cause blade or blade bolt failures.
- **REPLACE**, bent, damage, cracked and broken blades immediately with new blades.
- **AVOID** blade failures and thrown broken blades. **DO NOT** straighten, weld, or weld hard-facing blades.

### SAFETY SHIELDS, GUARDS AND SAFETY DEVICES INSPECTION:

- **KEEP** all Deflectors, Chain Guards, Steel Guards, Gearbox Shields, and PTO integral shields, Bands, Side Skirts and Skid Shoes in place and in good condition.
- **REPLACE** any missing, broken or worn safety shields, guards and safety devices.
- Engine Exhaust, some of its constituents, and certain vehicle components contain or emit chemicals known to the state of California to cause cancer, birth defects or other reproductive harm.
- Battery posts, terminals and related accessories contain lead and lead compounds, chemicals known to the state of California to cause cancer, birth defects or other reproductive harm. **PN HMBM-01**

**SAFETY**



# SAFETY

## PARTS INFORMATION

### PARTS INFORMATION

Tiger mowers use balanced and matched system components for blade carriers, blades, cuttershafts, knives, knife hangers, rollers, drivetrain components, and bearings. These parts are made and tested to Tiger specifications. Non-genuine "will fit" parts do not consistently meet these specifications. The use of "will fit" parts may reduce mower performance, void mower warranties, and present a safety hazard. Use genuine Tiger mower parts for economy and safety. (SPTM-1)

**SEE YOUR TIGER DEALER**

Operator's & Parts Manuals



[www.algqr.com/tpm](http://www.algqr.com/tpm)

**SAFETY**

# SAFETY

## Decal Location

**NOTE:** Tiger supplies safety decals on this product to promote safe operation. Damage to the decals may occur while in shipping, use, or reconditioning. Tiger cares about the safety of its customers, operators, and bystanders, and will replace the safety decals on this product in the field, free of charge (Some shipping and handling charges may apply). Contact your Tiger dealer to order replacement decals.

## Boom Arm

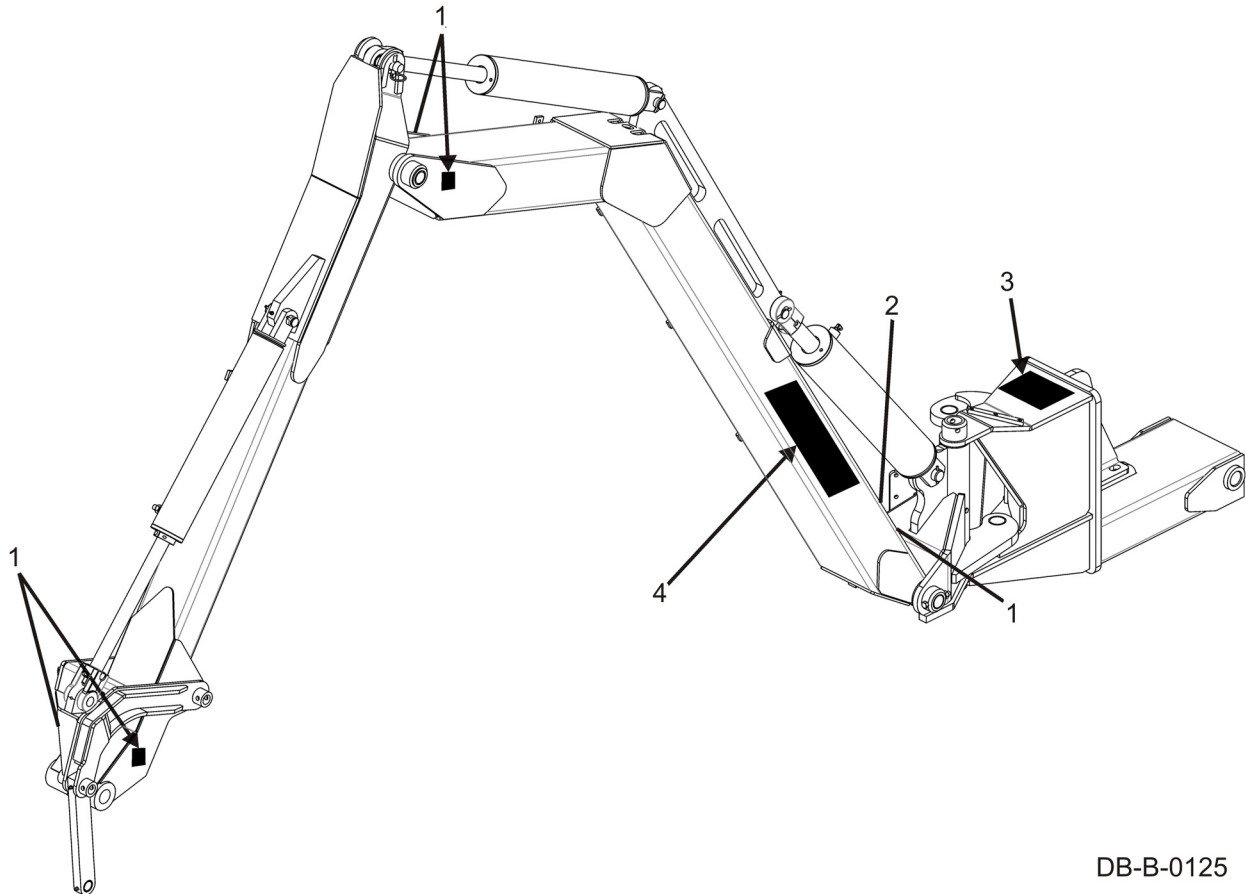

DB-B-0125

ITEM	PART NO.	QTY.	TYPE	DESCRIPTION
1.	02962764	5	WARNING	Pinch Points
2.	02965262	1	WARNING	Hydraulic Oil Hazard
3.	02962765	1	DANGER	Crushing Hazard
4.		1	LOGO	Name

# SAFETY

## 50" & 60" Rotary

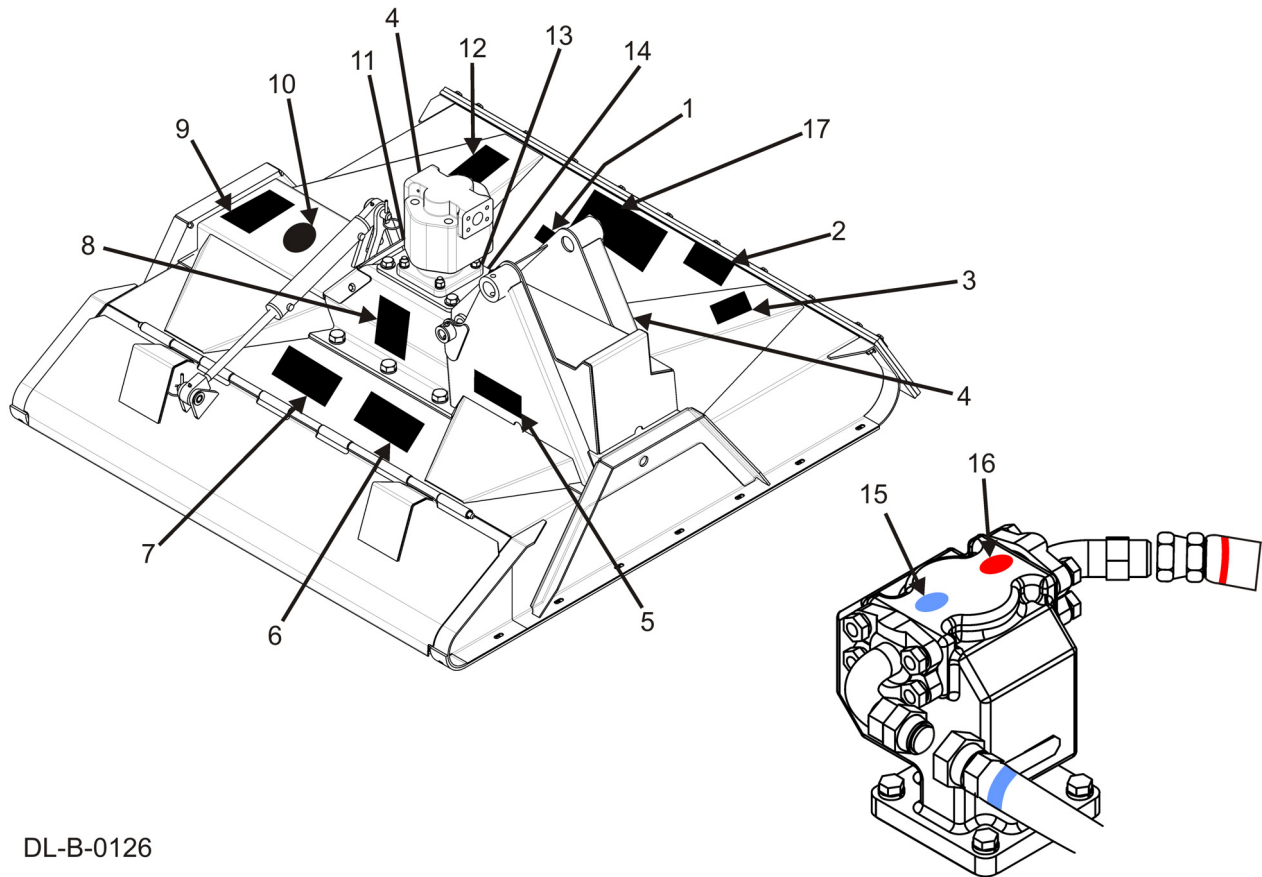

DL-B-0126

ITEM	PART NO.	QTY.	TYPE	DESCRIPTION
1.	6T3237	1	WARNING	Replace Blades
2.	24028	1	WARNING	Thrown Object Hazard
3.	D637	1	WARNING	Disconnect Hydraulic Solenoid
4.	42399	2	REFLECT	Red Reflector
5.	4240006	1	REFLECT	Amber Reflector
6.	D668	1	INSTRUCT	Lubrication Chart
7.	33224	1	DANGER	Blades, Thrown Object
8.	D619	1	WARNING	Blade Rotation
9.		1	LOGO	Made in the USA
10.		1	LOGO	Tiger Genuine Parts
11.	22839	1	INSTRUCT	Use Hand Grease Gun
12.	32709	1	WARNING	Use Genuine Tiger Parts
13.	6T3221	1	INSTRUCT	Lubrication Instructions
14.	nfs	1	SERIAL PLATE	Serial Number Plate
15.	06550058	1	INSTRUCT	Blue Dot
16.	06550057	1	INSTRUCT	Red Dot
17.		1	LOGO	Name

SAFETY

BOOM

Safety Section 1-17

# SAFETY

## 50" & 63" Flail

SAFETY

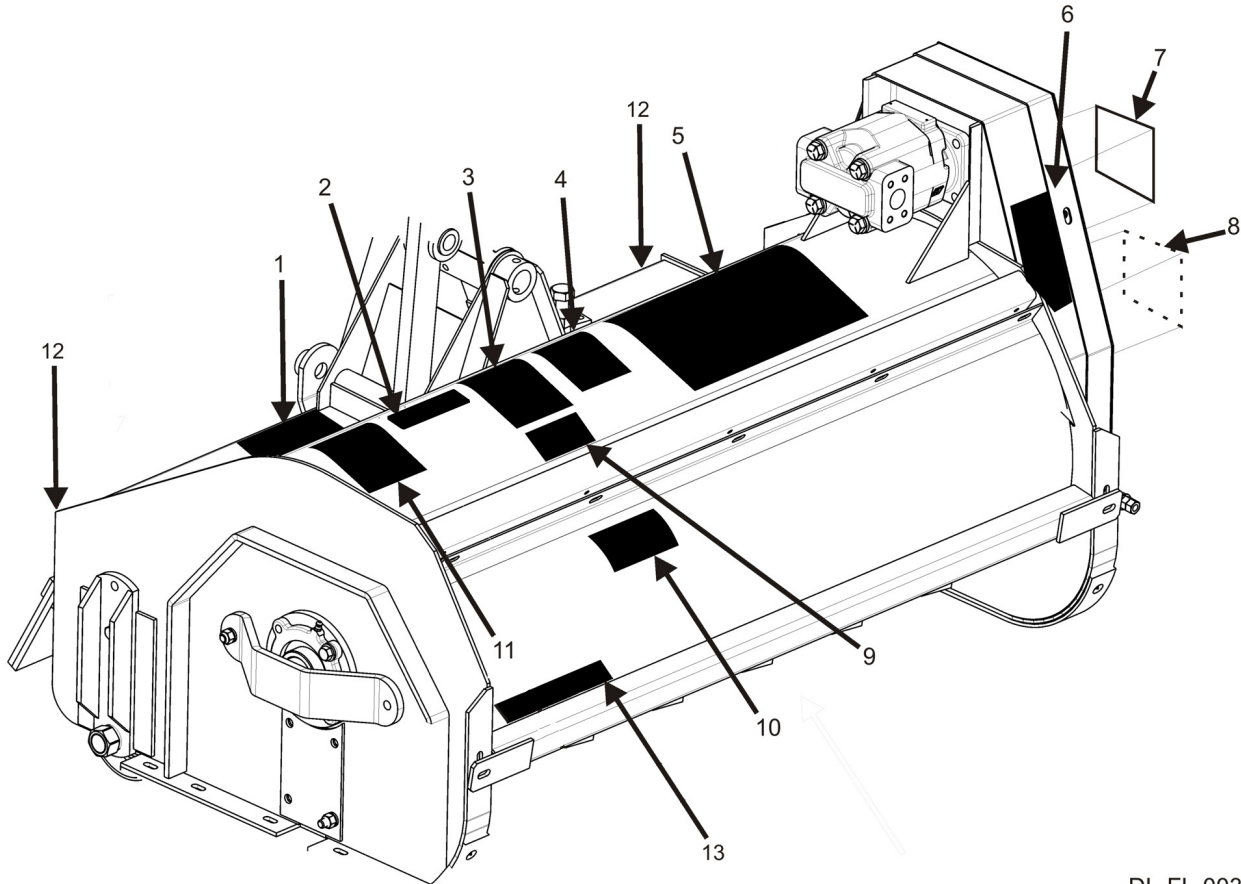

DL-FL-0031

ITEM	PART NO.	QTY.	TYPE	DESCRIPTION
1.	24028	1	DANGER	Thrown Object Hazard, Deflectors
2.	32709	1	WARNING	Use Genuine Tiger Parts
3.	33224	1	DANGER	Blades, Thrown Object
4.	D637	1	WARNING	Disconnect Hydraulic Solenoid
5.		1	LOGO	Tiger Logo
6.	00758194	1	WARNING	Pinch Point Hazard
7.		1	LOGO	50" Logo
		1	LOGO	63" Logo
8.	D646	1	DANGER	Guard Missing, Do Not Operate
9.	D655	1	INSTRUCT	Lube Chart
10.	TB1011	1	DANGER	Thrown Object Hazard, Shield
11.	6T3236	1	LOGO	Made in the USA
12.	42399	2	REFLECT	Red Reflector
13.	4240006	1	REFLECT	Amber Reflector
14.	nfs	1	SERIAL PLATE	Serial Number Plate

BOOM

Safety Section 1-18

# SAFETY



**TO AVOID SERIOUS INJURY OR DEATH FROM HIGH PRESSURE HYDRAULIC OIL LEAKS PENETRATING SKIN:**

- DO NOT OPERATE equipment with oil or fuel leaks.
- KEEP all hydraulic hoses, lines and connections in good condition and tight before applying system pressure.
- Relieve hydraulic pressure before disconnecting lines or working on the system.
- REMOVE and replace hose if you suspect it leaks. Have dealer test it for leaks.

**HIGH PRESSURE FLUID LEAKS CAN BE INVISIBLE. WHEN CHECKING FOR HYDRAULIC LEAKS AND WORKING AROUND HYDRAULIC SYSTEMS:**

- DO NOT use hands to check for leaks.
- ALWAYS WEAR safety glasses and impenetrable gloves.
- USE paper or cardboard to search for leaks.
- KEEP hands and body AWAY from pin holes and nozzles ejecting hydraulic fluid.
- Hydraulic fluid may cause gangrene if not surgically removed immediately by a doctor familiar with this form of injury.

02965262

**MOVING MACHINERY PARTS CAN PINCH OR CRUSH OR FALL-WHICH MAY CAUSE INJURY OR DEATH.**

02962765

SAFETY

# SAFETY

SAFETY

**⚠ DANGER**

**THROWN OBJECT HAZARD**

**TO AVOID SERIOUS INJURY OR DEATH:**  
DO NOT OPERATE if Thrown Object Shielding is damaged or missing.

- Maintain Rubber Deflectors in good condition.
- Inspect Rubber Deflectors frequently.

**MAINTAIN Thrown Object Shielding**

↙    **HERE**    ↘



24028

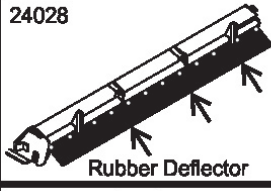

Rubber Deflector

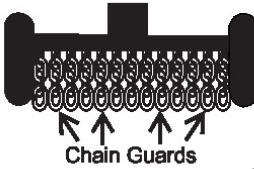

Chain Guards

**⚠ WARNING**

**TO AVOID SERIOUS INJURY OR DEATH FROM INADVERTENT MOWER HEAD START UP:**

• Disconnect the hydraulic solenoid BEFORE servicing the tractor or mower.

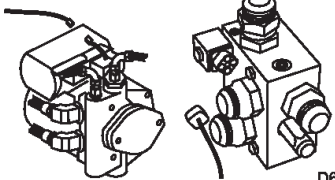

D637

**⚠ WARNING**

**TO AVOID SERIOUS INJURY OR DEATH FROM BLADE ATTACHMENT FAILURE:**

- Torque 1-1/8" blade bolt to 800 ft lbs.
- ALWAYS replace blades in pairs.
- ALWAYS replace blades with new bolts and nuts.

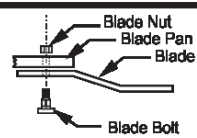

6T3237

**⚠ WARNING**

**TO AVOID SERIOUS INJURY AND DEATH FROM THROWN OBJECTS:**

• MAKE CERTAIN blades rotate the correct direction.

**BLADE ROTATION**

↶

D619

**Gear Motor**



**Piston Motor**

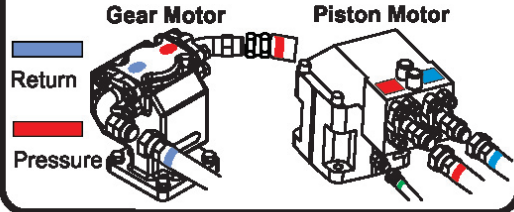

Return █

Pressure █



# SAFETY

SAFETY

**⚠ DANGER**



**THROWN OBJECTS HAZARD**

**Mower can throw objects up to 300 feet. TO AVOID SERIOUS INJURY OR DEATH to operator or bystanders:**

- CLOSE MOWER DOOR and STOP operating if bystanders or traffic come within 300 feet.
- KEEP door fully closed when cutting grass and weeds.
- OPEN door ONLY to cut large brush. Close door immediately after.
- DO NOT operate with door removed.
- KEEP door in place and in good condition during operation.
- Deflectors are SUBJECT TO WEAR. Replace if worn or damaged.
- ALWAYS transport with door closed. 33224

**ENTANGLEMENT HAZARD**



- STAY AWAY and KEEP hands, feet and body AWAY from rotating blades, drivelines and parts that continue to move after power shut-off. WAIT until all moving elements have stopped.
- STOP, LOOK and LISTEN for rotating motion before approaching implement.

# SAFETY

SAFETY

**⚠ WARNING**

**Non-genuine parts can fail catastrophically. TO AVOID SERIOUS INJURY OR DEATH:**

- ONLY use genuine TIGER replacement parts.
- Non-genuine parts can fail creating hazardous conditions for operator and bystanders.

Contact local dealer or TIGER about repair parts at:

3301 N. LOUISE AVE.,  
SIOUX FALLS, SD 57107      [www.algqr.com/tpm](http://www.algqr.com/tpm)  
Customer Service: 800-843-6849.  
Email: [feedback@tiger-mowers.com](mailto:feedback@tiger-mowers.com)      32709 1



**IMPORTANT**

<b>BE AWARE BE ALERT BE ALIVE</b>	<b>BE TRAINED Before Operating this Mower</b>	
---	---	---

To prevent serious injury to yourself and/or bystanders, be trained in Safe Mowing Practices. Alamo Group Companies as well as AEM and FEMA provide training material that is critical for your Safety and the Safety of others when operating this equipment. [www.algqr.com/tbv](http://www.algqr.com/tbv)  
Make these Safety Procedures an important part of every workday. Read and understand the Operator's Manual. Do not let untrained individuals operate this equipment. Contact your Dealer, AEM ([www.aem.org](http://www.aem.org)), FEMA (314-878-2304, [www.FarmEquip.org](http://www.FarmEquip.org)), or Alamo Group ([www.Alamo-Group.com](http://www.Alamo-Group.com)) for information on training material or courses that provide training in Safer Operating Practices for Mowers.      32709 2      32709

# SAFETY

SAFETY

<b>⚠ WARNING</b>	
<b>PINCH POINT HAZARD</b>	
<b>TO AVOID SERIOUS INJURY:</b> <ul style="list-style-type: none"><li>• DO NOT OPERATE with Belt Shield removed.</li></ul>	
00758194	

<b>⚠ DANGER</b>

D646
<b>GUARD MISSING DO NOT OPERATE</b>

<b>⚠ DANGER</b>	
<b>THROWN OBJECTS HAZARD</b>	
<b>Mower can throw objects up to 300 feet. TO AVOID SERIOUS INJURY OR DEATH to operator or bystanders:</b> <ul style="list-style-type: none"><li>• DO NOT operate with Shield removed.</li><li>• KEEP Shield in place and in good condition during operation.</li></ul>	
Tb1011	

# SAFETY

## Federal Laws and Regulations

This section is intended to explain in broad terms the concept and effect of federal laws and regulations concerning employer and employee equipment operators. This section is not intended as a legal interpretation of the law and should not be considered as such.

### Employer-Employee Operator Regulations

U.S. Public Law 91-596 (The Williams-Steiger Occupational and Health Act of 1970) OSHA

#### This Act Seeks:

“...to assure so far as possible every working man and woman in the nation safe and healthful working conditions and to preserve our human resources...”

#### DUTIES

Sec. 5 (a) Each employer-

- (1) shall furnish to each of his employees employment and a place of employment which are free from recognized hazards that are causing or are likely to cause death or serious physical harm to his employees;
- (2) shall comply with occupational safety and health standards promulgated under this Act.
- (b) Each employee shall comply with occupational safety and health standards and all rules, regulations and orders issued pursuant to this Act which are applicable to his own actions and conduct.

### OSHA Training Requirements

**Title 29, Code of Federal Regulations Part 1928.57(a)(6). [www.osha.gov](http://www.osha.gov)**

Operator instructions. At the time of initial assignment and at least annually thereafter, the employer shall instruct every employee who operates an agricultural tractor and implements in the safe operating practices and servicing of equipment with which they are or will be involved, and of any other practices dictated by the work environment.

Keep all guards in place when the machine is in operation;

Permit no riders on equipment

Stop engine, disconnect the power source, and wait for all machine movement to stop before servicing, adjusting, cleaning or unclogging the equipment, except where the machine must be running to be properly serviced or maintained, in which case the employer shall instruct employees as to all steps and procedures which are necessary to safely service or maintain the equipment.

Make sure everyone is clear of machinery before starting the engine, engaging power, or operating the machine.

### Employer Responsibilities:

To ensure employee safety during Tractor and Implement operation, it is the employer's responsibility to:

1. Train the employee in the proper and safe operation of the Tractor and Implement.
2. Require that the employee read and fully understand the Tractor and Implement Operator's manual.
3. Permit only qualified and properly trained employees to operate the Tractor and Implement.
4. Maintain the Tractor and Implement in a safe operational condition and maintain all shields and guards on the equipment.
5. Ensure the Tractor is equipped with a functional ROPS and seat belt and require that the employee operator securely fasten the safety belt and operate with the ROPS in the raised position at all times.
6. Forbid the employee operator to carry additional riders on the Tractor or Implement.
7. Provide the required tools to maintain the Tractor and Implement in a good safe working condition and provide the necessary support devices to secure the equipment safely while performing repairs and service.
8. Require that the employee operator stop operation if bystanders or passersby come within 300 feet.

### Child Labor Under 16 Years of Age

Some regulations specify that no one under the age of 16 may operate power machinery. It is your responsibility to know what these regulations are in your own area or situation. (Refer to U.S. Dept. of Labor, Employment Standard Administration, Wage & Home Division, Child Labor Bulletin #102.)

# ASSEMBLY SECTION

# ASSEMBLY

Before attempting to mount your Tiger mower, it is important to read and understand all of the safety messages in the Safety Section of this manual.

Before attempting to mount your Tiger mower, it is important to read and understand all of the safety messages in the Safety Section of this manual.



Before attempting to mount your Tiger mower, it is important to read and understand all of the safety messages in the Safety Section of this manual.

Before attempting to mount your Tiger mower, it is important to read and understand all of the safety messages in the Safety Section of this manual.

## TRACTOR PREPARATION

Before attempting to mount your Tiger mower, it is important to read and understand all of the safety messages in the Safety Section of this manual.

Before attempting to mount your Tiger mower, it is important to read and understand all of the safety messages in the Safety Section of this manual.

Before attempting to mount your Tiger mower, it is important to read and understand all of the safety messages in the Safety Section of this manual.

Before attempting to mount your Tiger mower, it is important to read and understand all of the safety messages in the Safety Section of this manual.

Before attempting to mount your Tiger mower, it is important to read and understand all of the safety messages in the Safety Section of this manual.

Before attempting to mount your Tiger mower, it is important to read and understand all of the safety messages in the Safety Section of this manual.

(ASM-JD-0001)

## CRANKSHAFT ADAPTER

Before attempting to mount your Tiger mower, it is important to read and understand all of the safety messages in the Safety Section of this manual.

(ASM-JD-0051)

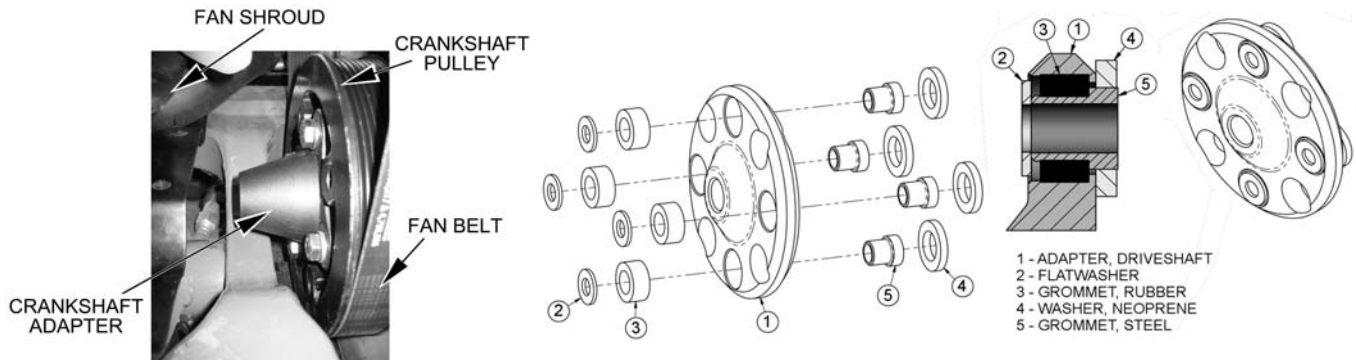

# ASSEMBLY

## FRONT CRANKSHAFT PULLEY

Vä^!Á@e Á[ } áÁ@eÁ@Á[ ] o&æ \ • @eá } ||^ Á • ááÁ Á @ Ö^!^Á q|Á [ o&æ [ , Á[!Á@Á  
 ä • o&ææ } Á ÁÁ [ ] o&æ^ Á • c { EY [ ~ Á q|Á^ ááÁ Á!á!Ááá^!^ } o^ ||^ Eä æ @!Áä áÁ [ |oÁ [ { Á @ Á  
 Ö^!^Á Á q|Á [ , Á[!ÁÁ [ ] o&æ^ Á Á Á^ Á • o&æ^ áá } Á [ ~!Áááq |E  
 Q • ] ^ & o Á @ Á [ ] o^ ||^ Á } Á [ ~!Áááq |Á Á^!á Á [ ~ Á @e Á @ Á [!^ & o Á } ||^ Á^ ááÁ Á [ ~ } o^  
 @ Á ] æ!Á |æ EÁ [ ~!Á } ||^ Á @e Á @ Á [ DÁ ]!Á q |Á^ ááÁ Á Á [ ~ } o^ @ Á ] æ!EÁ [ ~!Á } ||^ Á Á  
 @ Á [!^ & o Á } ^ Á^ ááÁ EÁ [ ~!Á } ||^ Á [ ^ Á [ @e Á @ Á [ DÁ ]!Á q |Á^ Á @ Á } ||^ EÁ [ ~ Á q|Á^ ááÁ  
 q Á!á!Á @ Á [!^ & o Á } ||^ Eä æ @!Áä áÁ [ |oÁ [ { Á @ Ö^!^Á E

**PARTS REQUIRED TO PURCHASE FROM JOHN DEERE:**

- U^ ||^ Á [ { Á Ö Á U Í F Í H G E
- Y æ @!Á [ { Á Ö Á U Í F Í G H
- Ó |oÁ [ { Á Ö Á U Í F Í I I
- V | ~ ^ Á } Á @ Á } ||^ Á [ |oÁ á o Á [ & c Á Á Á J Á a E d E

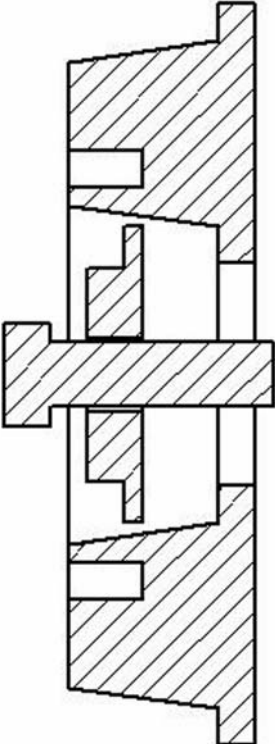

**Solution:**

FÉÖ!^ áá } Á [ ~!Á Áá } \ • @eá • ä \* Á Y F Í G Í Á Á áá } Áä áÁ^!^ Á!á!á^!  
 GÉÖ [ ] | Á Á @ Á [ { Á^ ááÁ Á Y F Í J Í J Á^ áá } ä \* Á [ ] [ ~ } áÁ [ ~ } áÁ @ Á^ áá } Á^ ááÁ Á @ Á  
 & ä \ • @eá [ • Á E  
 HÉÖ á Áá } |Á Á [ ~ } q \* Á & & ^, Á Á Á^ áá Á Ö Ö H E Á } ä^ Á q |Á [ , æ • Á^ ááÁ , Á & & ^, E  
 | E Á [ ~!Á } Áá } |Á Á [ ~ } ||^ Á } Á @ Á [ ä } \ • @eá } áÁ @ Á^ áá } & & ^, Á ] Á @ Á [ Á [ oÁ | Á } Á @ Á  
 & ä } & ^, Á Á } ||^ Á } ||^ Á d áá @ Á } q Á @ Á áá! E  
 Í E Á @ Á } Á & & ^, Á Á } ^ áá áá } Á E E { Á H J á E d Á @ Á } \* ä^ Á q |Á [ • oÁ | Á @e Á Á Á  
 ] ä^ áá E  
 Í E Á ^ áá^!^ Á } E ~ oÁ } Á @ Á } ||^ E Á ^ & Á Á E E H Á! Á • • E

(ASM-JD-0080)



# ASSEMBLY

## DRIVESHAFT AND FRONT PUMP MOUNTING

Q. 0. 1. 2. 3. 4. 5. 6. 7. 8. 9. 10. 11. 12. 13. 14. 15. 16. 17. 18. 19. 20. 21. 22. 23. 24. 25. 26. 27. 28. 29. 30. 31. 32. 33. 34. 35. 36. 37. 38. 39. 40. 41. 42. 43. 44. 45. 46. 47. 48. 49. 50. 51. 52. 53. 54. 55. 56. 57. 58. 59. 60. 61. 62. 63. 64. 65. 66. 67. 68. 69. 70. 71. 72. 73. 74. 75. 76. 77. 78. 79. 80. 81. 82. 83. 84. 85. 86. 87. 88. 89. 90. 91. 92. 93. 94. 95. 96. 97. 98. 99. 100. 101. 102. 103. 104. 105. 106. 107. 108. 109. 110. 111. 112. 113. 114. 115. 116. 117. 118. 119. 120. 121. 122. 123. 124. 125. 126. 127. 128. 129. 130. 131. 132. 133. 134. 135. 136. 137. 138. 139. 140. 141. 142. 143. 144. 145. 146. 147. 148. 149. 150. 151. 152. 153. 154. 155. 156. 157. 158. 159. 160. 161. 162. 163. 164. 165. 166. 167. 168. 169. 170. 171. 172. 173. 174. 175. 176. 177. 178. 179. 180. 181. 182. 183. 184. 185. 186. 187. 188. 189. 190. 191. 192. 193. 194. 195. 196. 197. 198. 199. 200. 201. 202. 203. 204. 205. 206. 207. 208. 209. 210. 211. 212. 213. 214. 215. 216. 217. 218. 219. 220. 221. 222. 223. 224. 225. 226. 227. 228. 229. 230. 231. 232. 233. 234. 235. 236. 237. 238. 239. 240. 241. 242. 243. 244. 245. 246. 247. 248. 249. 250. 251. 252. 253. 254. 255. 256. 257. 258. 259. 260. 261. 262. 263. 264. 265. 266. 267. 268. 269. 270. 271. 272. 273. 274. 275. 276. 277. 278. 279. 280. 281. 282. 283. 284. 285. 286. 287. 288. 289. 290. 291. 292. 293. 294. 295. 296. 297. 298. 299. 300. 301. 302. 303. 304. 305. 306. 307. 308. 309. 310. 311. 312. 313. 314. 315. 316. 317. 318. 319. 320. 321. 322. 323. 324. 325. 326. 327. 328. 329. 330. 331. 332. 333. 334. 335. 336. 337. 338. 339. 340. 341. 342. 343. 344. 345. 346. 347. 348. 349. 350. 351. 352. 353. 354. 355. 356. 357. 358. 359. 360. 361. 362. 363. 364. 365. 366. 367. 368. 369. 370. 371. 372. 373. 374. 375. 376. 377. 378. 379. 380. 381. 382. 383. 384. 385. 386. 387. 388. 389. 390. 391. 392. 393. 394. 395. 396. 397. 398. 399. 400. 401. 402. 403. 404. 405. 406. 407. 408. 409. 410. 411. 412. 413. 414. 415. 416. 417. 418. 419. 420. 421. 422. 423. 424. 425. 426. 427. 428. 429. 430. 431. 432. 433. 434. 435. 436. 437. 438. 439. 440. 441. 442. 443. 444. 445. 446. 447. 448. 449. 450. 451. 452. 453. 454. 455. 456. 457. 458. 459. 460. 461. 462. 463. 464. 465. 466. 467. 468. 469. 470. 471. 472. 473. 474. 475. 476. 477. 478. 479. 480. 481. 482. 483. 484. 485. 486. 487. 488. 489. 490. 491. 492. 493. 494. 495. 496. 497. 498. 499. 500. 501. 502. 503. 504. 505. 506. 507. 508. 509. 510. 511. 512. 513. 514. 515. 516. 517. 518. 519. 520. 521. 522. 523. 524. 525. 526. 527. 528. 529. 530. 531. 532. 533. 534. 535. 536. 537. 538. 539. 540. 541. 542. 543. 544. 545. 546. 547. 548. 549. 550. 551. 552. 553. 554. 555. 556. 557. 558. 559. 560. 561. 562. 563. 564. 565. 566. 567. 568. 569. 570. 571. 572. 573. 574. 575. 576. 577. 578. 579. 580. 581. 582. 583. 584. 585. 586. 587. 588. 589. 590. 591. 592. 593. 594. 595. 596. 597. 598. 599. 600. 601. 602. 603. 604. 605. 606. 607. 608. 609. 610. 611. 612. 613. 614. 615. 616. 617. 618. 619. 620. 621. 622. 623. 624. 625. 626. 627. 628. 629. 630. 631. 632. 633. 634. 635. 636. 637. 638. 639. 640. 641. 642. 643. 644. 645. 646. 647. 648. 649. 650. 651. 652. 653. 654. 655. 656. 657. 658. 659. 660. 661. 662. 663. 664. 665. 666. 667. 668. 669. 670. 671. 672. 673. 674. 675. 676. 677. 678. 679. 680. 681. 682. 683. 684. 685. 686. 687. 688. 689. 690. 691. 692. 693. 694. 695. 696. 697. 698. 699. 700. 701. 702. 703. 704. 705. 706. 707. 708. 709. 710. 711. 712. 713. 714. 715. 716. 717. 718. 719. 720. 721. 722. 723. 724. 725. 726. 727. 728. 729. 730. 731. 732. 733. 734. 735. 736. 737. 738. 739. 740. 741. 742. 743. 744. 745. 746. 747. 748. 749. 750. 751. 752. 753. 754. 755. 756. 757. 758. 759. 760. 761. 762. 763. 764. 765. 766. 767. 768. 769. 770. 771. 772. 773. 774. 775. 776. 777. 778. 779. 780. 781. 782. 783. 784. 785. 786. 787. 788. 789. 790. 791. 792. 793. 794. 795. 796. 797. 798. 799. 800. 801. 802. 803. 804. 805. 806. 807. 808. 809. 810. 811. 812. 813. 814. 815. 816. 817. 818. 819. 820. 821. 822. 823. 824. 825. 826. 827. 828. 829. 830. 831. 832. 833. 834. 835. 836. 837. 838. 839. 840. 841. 842. 843. 844. 845. 846. 847. 848. 849. 850. 851. 852. 853. 854. 855. 856. 857. 858. 859. 860. 861. 862. 863. 864. 865. 866. 867. 868. 869. 870. 871. 872. 873. 874. 875. 876. 877. 878. 879. 880. 881. 882. 883. 884. 885. 886. 887. 888. 889. 890. 891. 892. 893. 894. 895. 896. 897. 898. 899. 900. 901. 902. 903. 904. 905. 906. 907. 908. 909. 910. 911. 912. 913. 914. 915. 916. 917. 918. 919. 920. 921. 922. 923. 924. 925. 926. 927. 928. 929. 930. 931. 932. 933. 934. 935. 936. 937. 938. 939. 940. 941. 942. 943. 944. 945. 946. 947. 948. 949. 950. 951. 952. 953. 954. 955. 956. 957. 958. 959. 960. 961. 962. 963. 964. 965. 966. 967. 968. 969. 970. 971. 972. 973. 974. 975. 976. 977. 978. 979. 980. 981. 982. 983. 984. 985. 986. 987. 988. 989. 990. 991. 992. 993. 994. 995. 996. 997. 998. 999. 1000.

**CAUTION: DO NOT START THE TRACTOR UNTIL ALL HOSES ARE ATTACHED, TANK IS FILLED WITH PROPER OIL AND BALL VALVES ARE OPEN! STARTING AT THIS TIME WILL CAUSE SERIOUS DAMAGE TO THE PUMP.** (ASM-JD-0007)

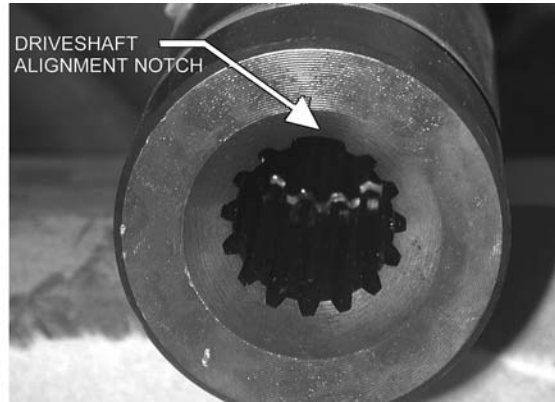
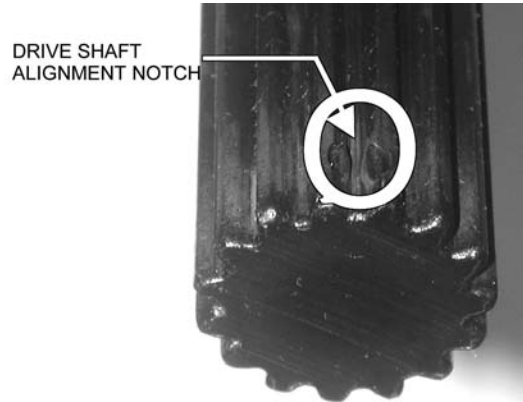

## ADJUSTING REAR WHEELS

Follow the instructions in the tractor owner's manual for adjusting tires and rims.





# ASSEMBLY

## POLYCARBONATE SAFETY WINDOW

*NOTE: Installing a boom mower requires that all of the right side windows be replaced or protected with a polycarbonate window. This should be done before mounting the mainframe.*

FEÜÖä & } ^ & Æ Á @ & Á & Á [ | ÈÜ ^ { [ ç ^ Á @ Á ã @ Á ã ^ Á & Á [ | È Ü ä á [ , Á | æ • Á { | Á & Æ | Á & Á à ^ Á ^ { [ ç ä \* Á ç \* ^ Á ä • ÈÜ Ö • ÈÜ ^ { [ ç ^ Á ^ æ Á ã @ Á ã ^ Á ä á [ , È Ü Ö ^ { [ ç ^ Á @ Á ç ä ç \* Á ç ä , æ ^ Á ä á Á & Æ Á & Æ | ^ Á | æ • Á [ | Á ä á ä á [ , È Ü Ö | æ ^ Á { æ | Á ^ æ Á Á & Æ @ • ä ^ Á ^ æ Á Á @ Á [ ç { Á Á @ Á ä Á | & Á à à ^ Á ^ æ È Ü Ö • ç | Á ä Á | & Á à à ^ Á ^ æ Á } Á [ | & Æ à ] æ ^ Á ç ç \* Á & Á @ Á } ç | Á [ ç { Á ç | ä [ ] ç | } È Ü Ö • ç | Á ç ç \* Á ç ä , æ ^ Á ^ { [ ç ^ Á | { Á | æ • Á [ | Á ä á ä á [ , Á } Á @ Á [ | & Æ à ] æ È Ü Ö • ç | Á @ Á [ | & Æ à ] æ Á • ^ { à | Á Á @ Á & Á ä @ Á ç ç \* Á ä á Á } ] | ä Á ç ä , æ È Ü Ö

(ASM-JD-0052 JD6xxxM T4F)



# ASSEMBLY

## MAINFRAME INSTALLATION

Y ã@Á} Á Ç^! @ ãáÁQ ã á} ã Á! Áã& É ç} ã • Éãã Á^} ^ Áã Á^ Á @ Áã ^ Á] Á Á @ Á Á || ^ ã d^ Á { ã&@ \* Á [ ^ } ç \* ÁQ | ^ • ÉÁQ • ç | Áã } • & ^ , • Á} ã Á @ | Á ç ã, ã ^ Á Á ^ & ^ | ^ Á @ Á ã ^ • Á Á @ Á { ã ã ã ^ Á Á Á @ Á ã ç d | Á ç ç \* Éã Á @ , } Á } Á @ Á ã ç d | Á [ ^ } Ó á Á ã ^ Á Á @ Á ã ç • Á Á ç | ÉÁ ÓÚÁ UVÁã @ } Áã Á @ Áã ^ ÉÁ Á { [ Ç Á @ Á ç } • & ^ , • Á } ^ Áã Áã Á ^ Á} ã Á} | Áã Á @ ã Á | & } \* Á ã ^ } ÉÁ Á } • ^ | Á @ Á ç } • & ^ , • Á} ã Á @ } Á Á | ~ ^ Á Á } ã ^ • Á [ Ç á Á Á @ Á | ~ ^ & ç d | & ç á Á @ Á ç ç } ã & Á Á ç } Á Á @ Á ç ã ç É (ASM-C-0003)

## SWITCHBOX WIRING

Ú | , ^ | Á | Á @ Á , ã&@ | Ç Á Áã& • • ^ á á @ | ~ \* @ @ Á | | Ç | & ç á Á } Á @ Áã @ Á ã Á Á @ Áã ÉÁ Ç Á @ Á ^ Á | \* Á Á ^ á Éã ç d { à ^ Á Ú Ö Í Í Í É Á Ó Ú Á UV Á } ^ & ç @ Á | \* Á Á @ Áã Á | | Ç ~ } ç Á @ Á ã ã \* Á Á } | | ^ Ç á É Á @ Á ã ^ • Á Á @ Á | \* Á ^ Á | | : á Á Ú Ö Í Ó Ó Ó Á ã á Á Ú Ç É Ó Ó É Á V @ Á Ú Ö Á ã Á } Á } ç • Á ^ Á @ Ç Á [ Á Á ^ á • Á Á Á Á } ^ á É Á ç ç } ^ & ç | Á | Í | Á | } á Á [ Á Ú Ö Á ã Á } á Á ^ Á ã Á ã Á } Á ~ | É Á V @ Á Ó Ó Ó Á ã á Á Ú Ç É Ó Ó Á ã Á ^ Á Q Ç } @ } Á d æ d | Á ^ Á Á } ^ á Á Á } É Á } ^ & ç @ Á Ó Ó Ó Á ã Á Á @ Á | \* Á Á @ Á Ó Ó Ó Á ã Á | { Á @ Á , ã&@ | Ç Á V @ } Á } ^ & ç @ Á Ú Ç É Ó Ó Á ã Á Á @ Á | \* Á Á @ Á Ú Ö Á ã Á | { Á @ Á , ã&@ | Ç Á

**IMPORTANT:** In some cases the red and orange wires may be switched. Á Ç Á Ç Á Á • Ó

@ Á ã ^ • Á Á Á Á | ç } Á @ Ç Á ã Á Á @ Ç V @ Á [ Á Ú Ö Ó Á ã ^ Á ~ • Ó Á Á } ^ & ç á Á Á @ Á ^ Ç Á ç Á ã Á Á ç \* Á @ Á ^ Ç Á • ç Á ã Á } ^ & ç \* Á } ^ Á Ú Ö Ó Á ã Á Á } ^ Á } á Á á @ Á Á } á Á Ú Ö Ó Á ã Á Á @ Á | Ç | É Á ^ Á | Á @ Á , ã&@ | Ç Á & @ { ã Á } á Á ã \* Á ã | ç Á | Á ã á } ç } É V @ Á ^ Ç Á Ú ç Á ã Á Á Á | , } Á ã Á | & ç á Á } á | Á Ç Á \* Á | { } É Á Ó Á Á | Ç Á @ Á ã Á Á | { } Á Á Á • • É Á Ç V Ó Á Ú W Á | Á ç ç \* Á ã • É Ç Á | Á } ^ & ç \* Á @ Á | , ^ | Á Á @ Á , ã&@ | Ç Á | ~ Ç Á @ Á Ç Á ã Á } \* Á @ Áã | ^ Á | Á , á • Á Á @ Á | ^ } | ã Á ç Á É (ASM-JD-0245)



# ASSEMBLY

## WEATHER-PACK / METRI-PACK ASSEMBLY

V@•^Á [i•Á^Á] &œ áÁœÁ@Á^œÁ-Á@Á^œÁ iÉ} áÁÁ@ÁœÁœÁ^É } @Á^Á@ÁœÁ^Á

**NOTE: Use the specific tool for the type of connector you are assembling.**

(ASM-C-0009)

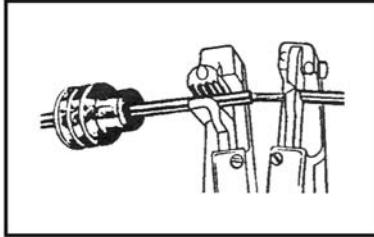

1. Apply seal to cable, before stripping insulation.



2. Align seal with cable insulation.

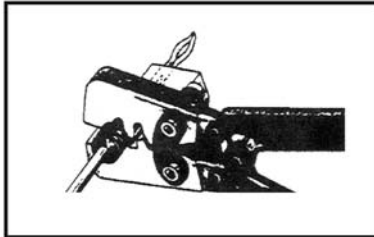

3. Put terminal in crimping tool, then position wire and seal in place.

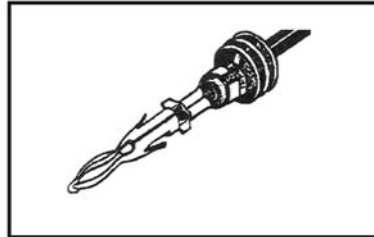

4. Crimp and visually inspect for a good crimp before installing in connector body.

## HYDRAULIC PORTS

V@•^Á [i•Á^Á] &œ áÁœÁ@Á^œÁ-Á@Á^œÁ iÉ} áÁÁ@ÁœÁœÁ^É } @Á^Á@ÁœÁ^Á  
 { [ ~ } ç \* ÁÁœÁ ^œÁœÁ@•Á Á@Á^œÁ iÉV@Á œÁ^Á} •^Á [i•Á^Á] Á [É@} Á@Á^•~ ÁÁœÁ áÁ  
 ç œÁ Á@Á^œÁ} Á [i•Á^Á] , Á@Á^œÁ^Á Á@Á^œÁ^Á &œ } Á ÁÁœÁ} œÁ  
 ç f { œÁ } ÉÁ (ASM-JD60-7030-0004)

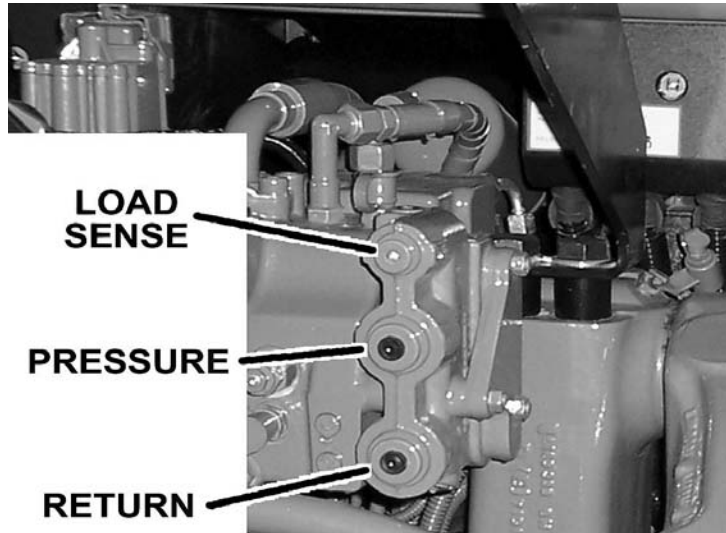

LOAD  
SENSE

PRESSURE

RETURN



# ASSEMBLY

## PRESSURE LINE INSTALLATION

V@Á@á:æ |æÁ |^·· |^Áæ Áæ q|æ^Á | { à^áÆ ç Á@Á^æÁ Á@Áæç |Á^ [ ç^çç^ÈS |æÁ c@Á |^·· |^Á | |ç } Á@Á^æÁ { [ ç^ç ç^Á^ [ ç^Á@Á | \* Ç^Á |Á Á@Á^ áæ |æÁ | |ç Á q | · dææ } Áæ á@Áæ Á^ &ç } Áæ Á^ Á |Á | · ææ } Á Á@Á |^·· |^Á | |ç Á | \* Á Á !^ [ ç^áÆ · ç |Á | { { Áææ ç |Á |Á |à |, ÈÁ Á^ ççæ } } ^ &çççççç ç^Á | { Á@Áæç |Á^ [ ç^çççççç Á@Á Vá^ |Áçç^È (ASM-27mmPRESSURE-0001)

## RETURN LINE INSTALLATION

V@Á^ç | } Áæ Áæ q|æ^Á | { à^áÆ çççççç Á@Á |^·· |^Áæ Áæ } Á@Áæç |Á^ [ ç^çççççç ÈS |æÁ c@Á^ç | } Á | |ç } Á^Á^ [ ç^Á@Á | \* Ç^Á |Á Á@Á^ áæ |æÁ | |ç Á | · dææ } Áæ á@Áæ Á^ &ç } Á |Á@Á | · ææ } Á Á@Á^ç | } Á | |ç Á | \* Á Á^ [ ç^áÆ · ç |Á | { { Áææ ç |Á |Á |à |, ÈÁ Á^ ççæ } } ^ &çççççç ç^Á | { Á@Áæç |Á^ [ ç^çççççç Á@Á Vá^ |Áçç^È (ASM-27mmRETURN-0001)

## LOAD SENSE LINE INSTALLATION

V@Á |æÁ ^ · ^ Áæ Áæ q|æ^Á | { à^áÆ ç Á@Á | ç { Á Á@Áæç |Á^ [ ç^çççççç Á^Á |Á Á@Á P^ áæ |æÁ | |ç Á | · dææ } Áæ á@Áæ Á^ &ç } Áæ Á^ Á |Á@Á | · ææ } Á Á@Á |æÁ ^ · ^ Á | |ç Á S |æÁ Á@Á | \* Á } Á@Áæç |ÁæÁ^ [ ç^Á |Á@Á |æÁ ^ · ^ Áæ ç Á^ [ ç^Á@Á | \* ÈQ · ç |Á Á FI { { Áææ ç |Á |Á |à |, Áæ á } Áçççççç ç^Á | { Á@Á^ [ ç^Á Á@Á Vá^ |Áçççççç Á@Á Úæç Á^ &ç } Áæ Á^ Áæ Á ç | | à^áÆ æ |æ Á Á@Áæç |Á^ [ ç^çççççç Á@Á ] È (ASM-14mmLOAD SENSE-0001)

## VALVE MOUNTING

V@Á | ^ } ç \* Á |æÁ ^ ç |Á RÖÁ çççççç Áæç |Á^ · Áæ |Á^ [ Á | } \* Á · Á çççççç Á^á ç Á^ Áææç ç Á^ Á ç, } Á Á@Á ç ç Á^ |, ÈÁ^ & |Á Á@Á |æÁ ^ ç Á@Áæç |Á æç c@Á ç ç Á ç, } Á Á@Áæç Á^ &ç } Á Á@Á æ ç çççççç Á@Á ç |Á@Á ç Á^ Á@Á P^ · ç |Á | d | |çççççç Áæ Áæ | ç |Á@Á ç ç · çççççç } Á@Áçççç |æÈÁ @ | Áæ } Á@Á ç |Á^ } Á@Áçççççç æçççççç çççççç Á@Á ç |Á^ & ^ Á@Á çççççç } Á | Á Á@Á | ^ } ç \* Á ] æ ÈÁ | ^ ç Á@Á ç |æ Áæ Á^ { { Á@Á çççççç Á@Á ç |æ Áæ |á | · Á @Á | ç^áÆ } Á çç Á çççççç Áæ Á^ Á@Áæç Á^ &ç } ÈQ · ç |Á @Á | d | |çççççç Á@Á çççççç á@Á { [ ] ç \* Á |æ Á } Á@Á · ç |çççççç ÈÁ Á@Á ç ç · çççççç Èæçççççç Á^ &çççççç d | |Á çççççç ÈÁ (ASM-JD7X30-0001 JD6140R)

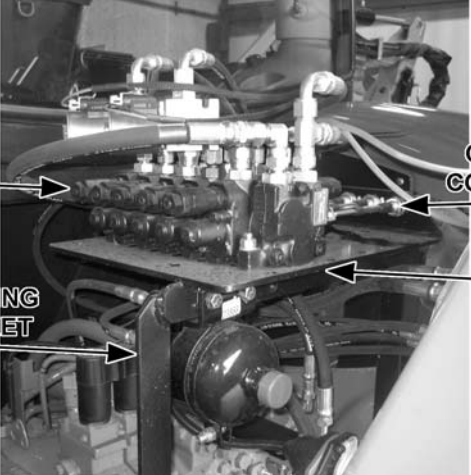

VALVE  
MOUNTING BRACKET

CABLE CONTROL  
VALVE PLATE

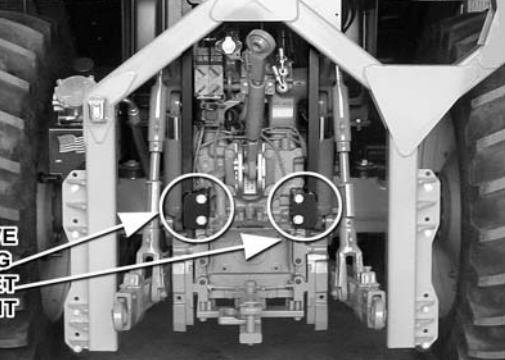

VALVE MOUNTING BRACKET ATTACHMENT



# ASSEMBLY

## \*NOTE ON HUSCO CONTROL VALVES\*

T a) ~ a) d) e) f) g) h) i) j) k) l) m) n) o) p) q) r) s) t) u) v) w) x) y) z) A) B) C) D) E) F) G) H) I) J) K) L) M) N) O) P) Q) R) S) T) U) V) W) X) Y) Z) AA) AB) AC) AD) AE) AF) AG) AH) AI) AJ) AK) AL) AM) AN) AO) AP) AQ) AR) AS) AT) AU) AV) AW) AX) AY) AZ) BA) BB) BC) BD) BE) BF) BG) BH) BI) BJ) BK) BL) BM) BN) BO) BP) BQ) BR) BS) BT) BU) BV) BW) BX) BY) BZ) CA) CB) CC) CD) CE) CF) CG) CH) CI) CJ) CK) CL) CM) CN) CO) CP) CQ) CR) CS) CT) CU) CV) CW) CX) CY) CZ) DA) DB) DC) DD) DE) DF) DG) DH) DI) DJ) DK) DL) DM) DN) DO) DP) DQ) DR) DS) DT) DU) DV) DW) DX) DY) DZ) EA) EB) EC) ED) EE) EF) EG) EH) EI) EJ) EK) EL) EM) EN) EO) EP) EQ) ER) ES) ET) EU) EV) EW) EX) EY) EZ) FA) FB) FC) FD) FE) FF) FG) FH) FI) FJ) FK) FL) FM) FN) FO) FP) FQ) FR) FS) FT) FU) FV) FW) FX) FY) FZ) GA) GB) GC) GD) GE) GF) GG) GH) GI) GJ) GK) GL) GM) GN) GO) GP) GQ) GR) GS) GT) GU) GV) GW) GX) GY) GZ) HA) HB) HC) HD) HE) HF) HG) HH) HI) HJ) HK) HL) HM) HN) HO) HP) HQ) HR) HS) HT) HU) HV) HW) HX) HY) HZ) IA) IB) IC) ID) IE) IF) IG) IH) II) IJ) IK) IL) IM) IN) IO) IP) IQ) IR) IS) IT) IU) IV) IW) IX) IY) IZ) JA) JB) JC) JD) JE) JF) JG) JH) JI) JJ) JK) JL) JM) JN) JO) JP) JQ) JR) JS) JT) JU) JV) JW) JX) JY) JZ) KA) KB) KC) KD) KE) KF) KG) KH) KI) KJ) KK) KL) KM) KN) KO) KP) KQ) KR) KS) KT) KU) KV) KW) KX) KY) KZ) LA) LB) LC) LD) LE) LF) LG) LH) LI) LJ) LK) LL) LM) LN) LO) LP) LQ) LR) LS) LT) LU) LV) LW) LX) LY) LZ) MA) MB) MC) MD) ME) MF) MG) MH) MI) MJ) MK) ML) MM) MN) MO) MP) MQ) MR) MS) MT) MU) MV) MW) MX) MY) MZ) NA) NB) NC) ND) NE) NF) NG) NH) NI) NJ) NK) NL) NM) NN) NO) NP) NQ) NR) NS) NT) NU) NV) NW) NX) NY) NZ) OA) OB) OC) OD) OE) OF) OG) OH) OI) OJ) OK) OL) OM) ON) OO) OP) OQ) OR) OS) OT) OU) OV) OW) OX) OY) OZ) PA) PB) PC) PD) PE) PF) PG) PH) PI) PJ) PK) PL) PM) PN) PO) PP) PQ) PR) PS) PT) PU) PV) PW) PX) PY) PZ) QA) QB) QC) QD) QE) QF) QG) QH) QI) QJ) QK) QL) QM) QN) QO) QP) QQ) QR) QS) QT) QU) QV) QW) QX) QY) QZ) RA) RB) RC) RD) RE) RF) RG) RH) RI) RJ) RK) RL) RM) RN) RO) RP) RQ) RR) RS) RT) RU) RV) RW) RX) RY) RZ) SA) SB) SC) SD) SE) SF) SG) SH) SI) SJ) SK) SL) SM) SN) SO) SP) SQ) SR) SS) ST) SU) SV) SW) SX) SY) SZ) TA) TB) TC) TD) TE) TF) TG) TH) TI) TJ) TK) TL) TM) TN) TO) TP) TQ) TR) TS) TT) TU) TV) TW) TX) TY) TZ) UA) UB) UC) UD) UE) UF) UG) UH) UI) UJ) UK) UL) UM) UN) UO) UP) UQ) UR) US) UT) UU) UV) UW) UX) UY) UZ) VA) VB) VC) VD) VE) VF) VG) VH) VI) VJ) VK) VL) VM) VN) VO) VP) VQ) VR) VS) VT) VU) VV) VW) VX) VY) VZ) WA) WB) WC) WD) WE) WF) WG) WH) WI) WJ) WK) WL) WM) WN) WO) WP) WQ) WR) WS) WT) WU) WV) WW) WX) WY) WZ) XA) XB) XC) XD) XE) XF) XG) XH) XI) XJ) XK) XL) XM) XN) XO) XP) XQ) XR) XS) XT) XU) XV) XW) XX) XY) XZ) YA) YB) YC) YD) YE) YF) YG) YH) YI) YJ) YK) YL) YM) YN) YO) YP) YQ) YR) YS) YT) YU) YV) YW) YX) YY) YZ) ZA) ZB) ZC) ZD) ZE) ZF) ZG) ZH) ZI) ZJ) ZK) ZL) ZM) ZN) ZO) ZP) ZQ) ZR) ZS) ZT) ZU) ZV) ZW) ZX) ZY) ZZ)

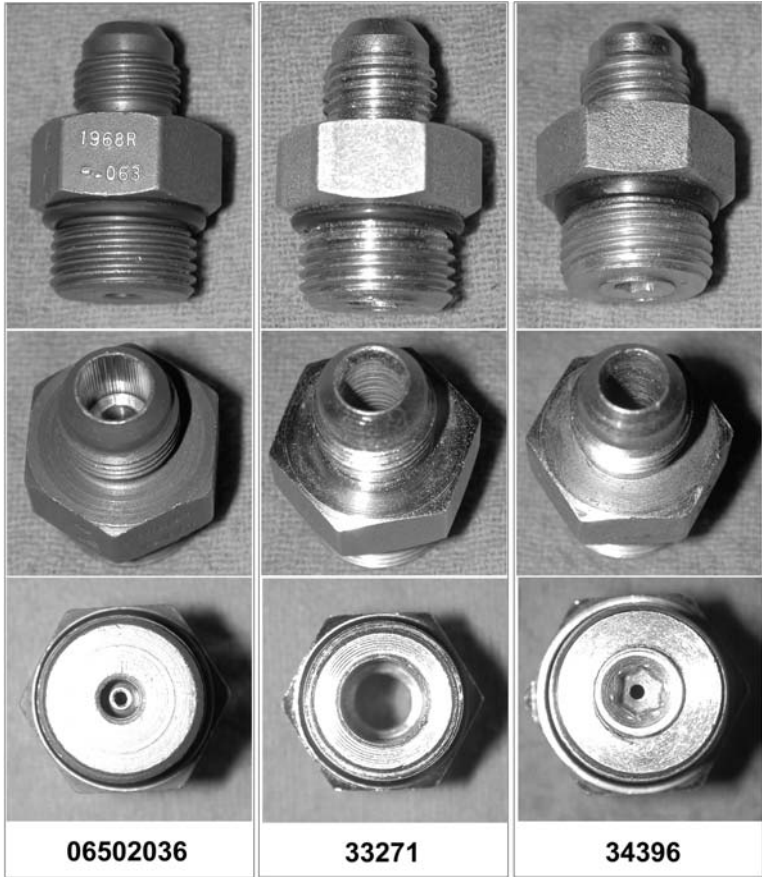

# ASSEMBLY

## ELECTRONIC LIFT VALVE PORTS

(ASM-C-0089)

### DANFOSS VALVE

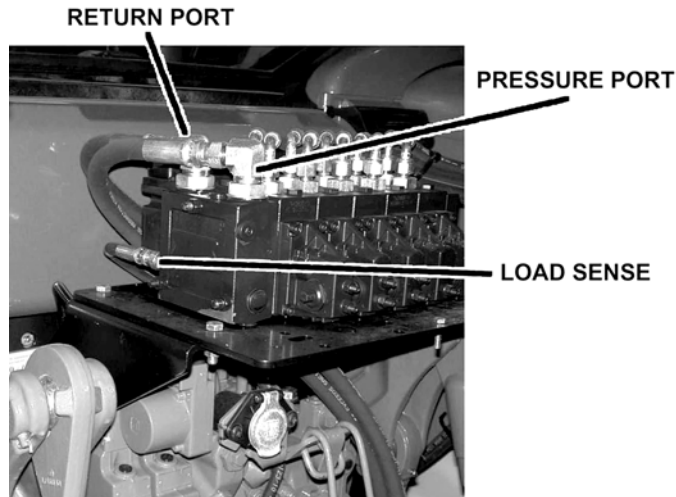

## JOYSTICK SWITCHBOX MOUNTING

Diagram illustrating the joystick switchbox mounting. The switch box is mounted to the tractor frame using bolts. The mower run knob is also visible on the switch box. (ASM-JD-0081)

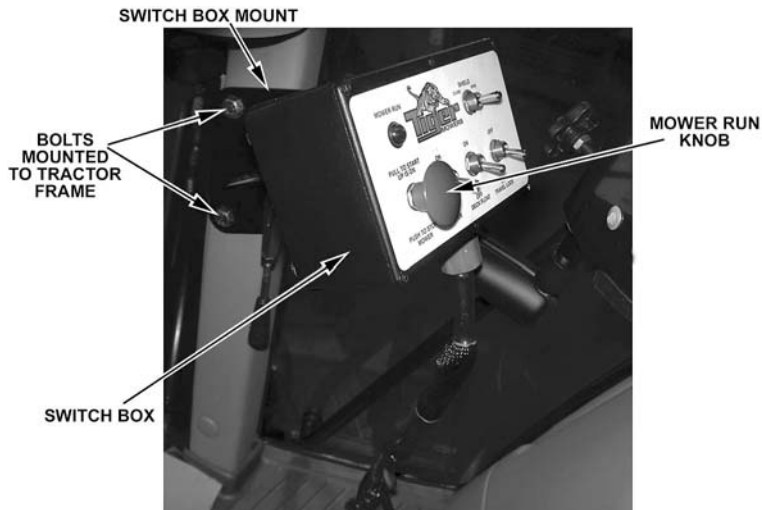

# ASSEMBLY

## JOYSTICK CONTROL MOUNTING

T [ ~ } ç \* Ác@Áþ ~ • çã Á& } d [ |Á! ^ ~ ã ^ Ác@Ác@ Á!ã @Áæ { ! ^ • ó ñ ^ Á { [ áãã áÁã ã Áã }  
 æãããã } æ! Æ! æ! ^ ó Æ æ Æ @ á Á } Á æ } { [ á æ Ác@ Áþ ~ • çã Æ ÁV @ Áæ { ! ^ • ó ñ ^ ~ • ó Æ Á ^ { [ ç á Æ ^  
 • |ãã \* Á ~ Ác@ Á } æ çã Á ç! Áæ ã Á { [ çã \* Ác@ Áæ } & ^ , Á [ { Ác@ Áþ , ^! Áã @ Á Æ Á ^ Ác@ Á ^ æ Æ  
 V @ Á } ç! Á æ Ác@ Áæ { ! ^ • ó ñ [ • Á [ Á Áæ } Á Á ^ { [ ç á Æ Á ] & Ác@ Áæ { ! ^ • ó ñ Á ^ { [ ç á Æ | æ &  
 c @ Áþ ^ • çã Á ç | á ^! Á } á ^! Ác@ Áæ { ! ^ • ó ñ [ Ác@ Áþ á ^ } æã } Á } Ác@ Áþ ~ • çã Á ^ Ác@ Áæ { ! ^ • ó ñ  
 |ã á Á } Á æ çã Á ç | á ^ Ác@ Áæ { ! ^ • ó ñ Æ! æ! ^ ó ñ æ! çã Á ç | á ^ , Á ç! Á ^ á Á } Á æ • Ác@ ~ \* @ Æ  
 U } & Ác@ Áæ Á ç ^ á Á } Æ Á æ! Ác@ Áæ { ! ^ • ó ñ @! Ác@ Á ç | á } æ • Ác@ ~ \* @c@ Áæ { ! ^ • c  
 à! æ! ^ Æ Ác@ Áæ + Á ç | á } ~ • ó ñ Á! ç! á Ác@ ~ \* @c@ Áæ { ! ^ • ó ñ Ác@ Ác@ Áæ! æ! ^ ó ñ Æ! Á  
 • ^ & ! ^ á Æ Ác@ Á ç | á ç! Á ç! Á ç! á } Ác@ Á ç! á ç! á } Ác@ Á ç! á } Ác@ Á ç! á } Ác@ Á ç! á } Ác@ Á ç! á } Ác@ Á ç! á }  
 & Á ç! Á æ! ^! Á æ! ^! Á } Ác@ Á ^ ç! á } æ! Ác@ Áæ { ! ^ • ó ñ [ Ác@ Áæ ] æ! Áç á Ác@ Á ç! c  
 & ç! Ác@ Á ç!  
 [ ] Ác@ Áæ { ! ^ • ó ñ æ! Ác@ Áæ , æ! Á ç , } æ! Ác@ Á ç! Á ç! Á ç! Á ç! Á ç! Á ç! Á ç! Á ç! Á ç! Á ç! Á ç! Á ç!  
 ! ^ Æ æ æ @ Ác@ Áæ { ! ^ • ó ñ Ác@ Á ^ æ! Á ç \* Ác@ Á ç! Á ç! Á ç! Á ç! Á ç! Á ç! Á ç! Á ç! Á ç! Á ç! Á ç! Á ç! Á ç!  
 ç • ç! Ác@ Áþ ~ • çã Á ç! Á ç! Á ç! Á ç! Á ç! Á ç! Á ç! Á ç! Á ç! Á ç! Á ç! Á ç! Á ç! Á ç! Á ç! Á ç! Á ç! Á ç!  
 Û ~ • Ác@ Á ç!  
 Ô [ ç! Á ç!  
 } á ^ á ç! á ç! Á ç! Á ç! Á ç! Á ç! Á ç! Á ç! Á ç! Á ç! Á ç! Á ç! Á ç! Á ç! Á ç! Á ç! Á ç! Á ç! Á ç! Á ç!  
 ] • Ác@ Á ^ & • æ Æ ASM-JD-0082

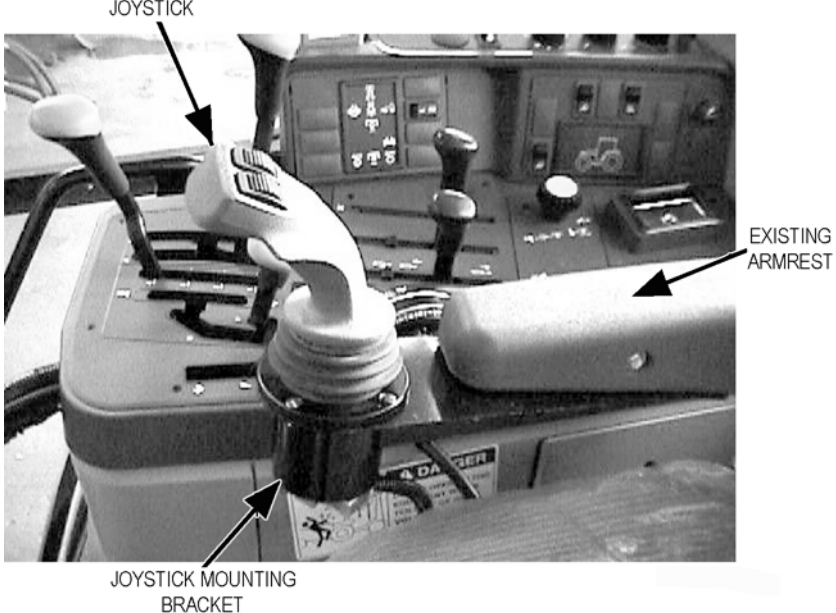







# ASSEMBLY

## BOOM JOYSTICK CONTROL CALIBRATION (CONTINUED)

**MAIN BOOM:** %EÁU|:CÖQ|[{ ÅM|K ì ÈÊÁ^& }â•

(Note: Extend secondary boom completely; roll deck to be level with ground, and lower main boom until deck is on ground. Now index main boom “up” function and determine the time required for main boom to rise completely.)

%OÁU|:CÖQ|[{ ÅÖ|, }K ì È Ê Á^& }â•

(Note: Extend secondary boom completely, roll deck to be level with ground, and raise the main boom to “full up”. Then index the main boom “down” function to determine the amount of time required for the deck to contact the ground. CAUTION: Stop the boom just as the deck contacts the ground.)

### SECONDARY

**BOOM:** %EÁU|:CÖQ|[{ ÅJ~|K ì ÈÊÁ^& }â•

(Position main boom full up, roll deck out until deck cylinder is fully retracted, and bring secondary boom in completely. Then index the secondary boom “out” function and determine the time required for boom to extend out completely.)

Å

%OÁU|:CÖQ|[{ ÅQ|K ì È Ê Á^& }â•

(Position the main boom full up, roll deck out until deck cylinder is fully retracted, and extend secondary boom completely. Then index the secondary boom “in” function and determine the time required for boom to come in.)

**DECK ROLL:** %EÁU|:CÖ^& ÅJ~|K ì È Ê Á^& }â•

(Raise main boom to vertical, extend secondary boom out slightly so that deck can be articulated without contacting the main boom, and roll deck in until deck cylinder is completely extended. Then index the deck roll “out” function and determine the time required for the deck to roll out.)

%OÁU|:CÖ^& ÅQ|K ì È Ê Á^& }â• ÅQ~ ÖUÁUVÁ^ ÅSá aU&^, D

(Raise main boom to vertical, extend secondary boom out slightly so that deck can be articulated without contacting the main boom, and roll deck out until deck cylinder is completely retracted. Then index the deck roll “in” function and determine the time required for the deck to roll in.)

### BOOM

**SWIVEL:** %EÁU|:CÖQ|[{ ÅEö|K ì È Ê Á^& }â• ÅÁ! ÅUÜÊHUÜÊUÜ

(Extend booms completely; rotate head to be level with ground, lower main boom until deck is just above ground, and swivel boom full forward. Then index the boom swivel “aft” function and determine the time required for the boom to swivel full aft. Use caution when doing this, stop boom before main boom contacts tire.)

%OÁU|:CÖQ|[{ ÅQ|, æåK ì È Ê Á^& }â• ÅÁ! ÅUÜÊHUÜÊUÜ

(Extend booms completely, rotate head to be level with ground, lower main boom until deck is just above ground, and swivel boom aft until near tire. Then index the boom swivel “forward” function and determine the time required for the boom to swivel full forward.)

(ASM-C-0082)



# ASSEMBLY

## BOOM JOYSTICK DIAGRAM (ASM-C-0082A)

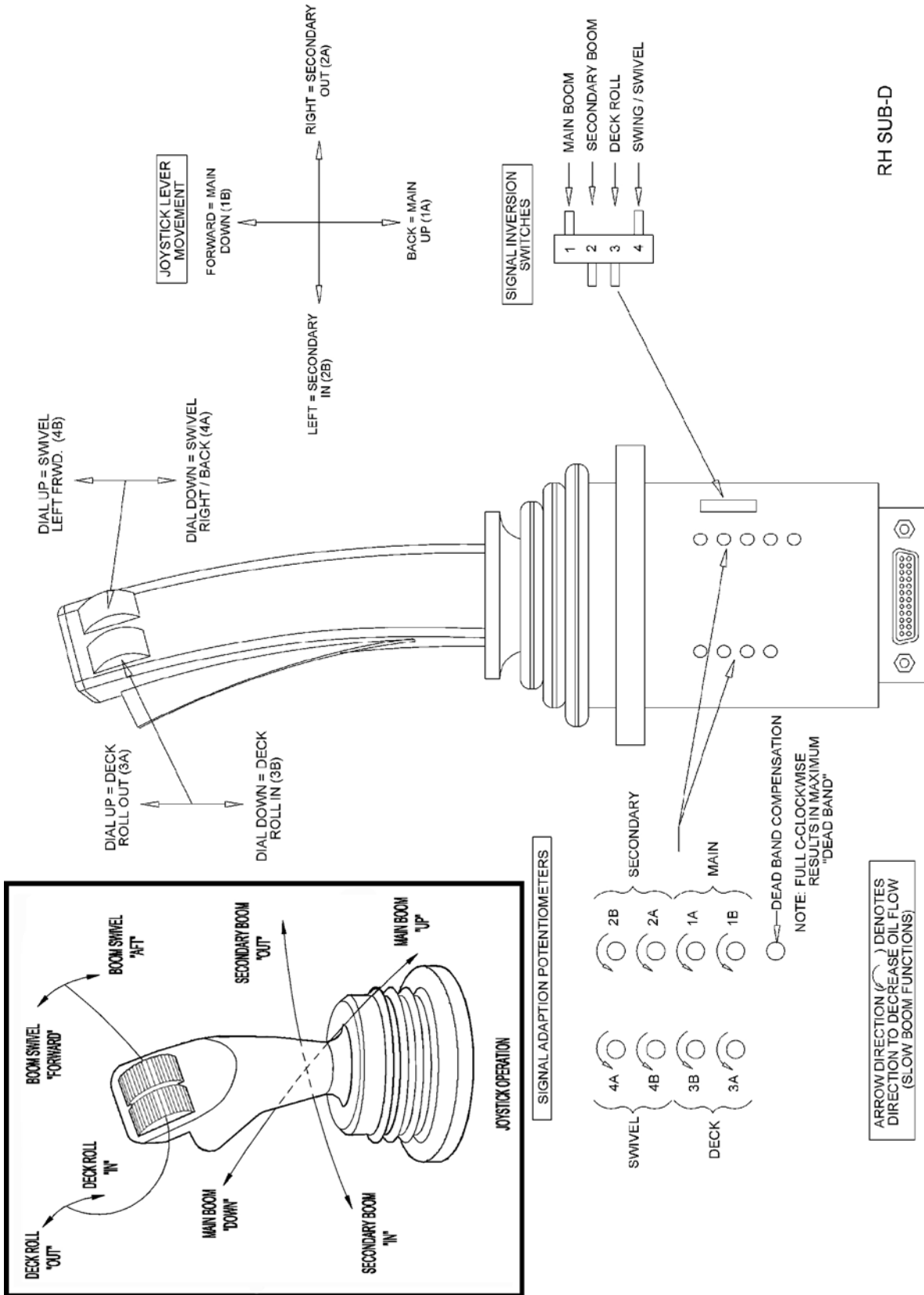

# ASSEMBLY

## REAR STOW BENGAL HOSE ROUTING

**WARNING NOTE:** Do not use the hose routing diagram as a guide for routing the hose. The hose routing diagram is only a reference. The actual routing of the hose must be done in accordance with the instructions in the operator's manual. Failure to follow the instructions may result in damage to the hose or the machine.



The hose routing diagram is only a reference. The actual routing of the hose must be done in accordance with the instructions in the operator's manual. Failure to follow the instructions may result in damage to the hose or the machine. (ASM-T4 HOSE ROUTING-0001)



# ASSEMBLY

(ASM-C-0023)

## BOOM HYDRAULIC DIAGRAM

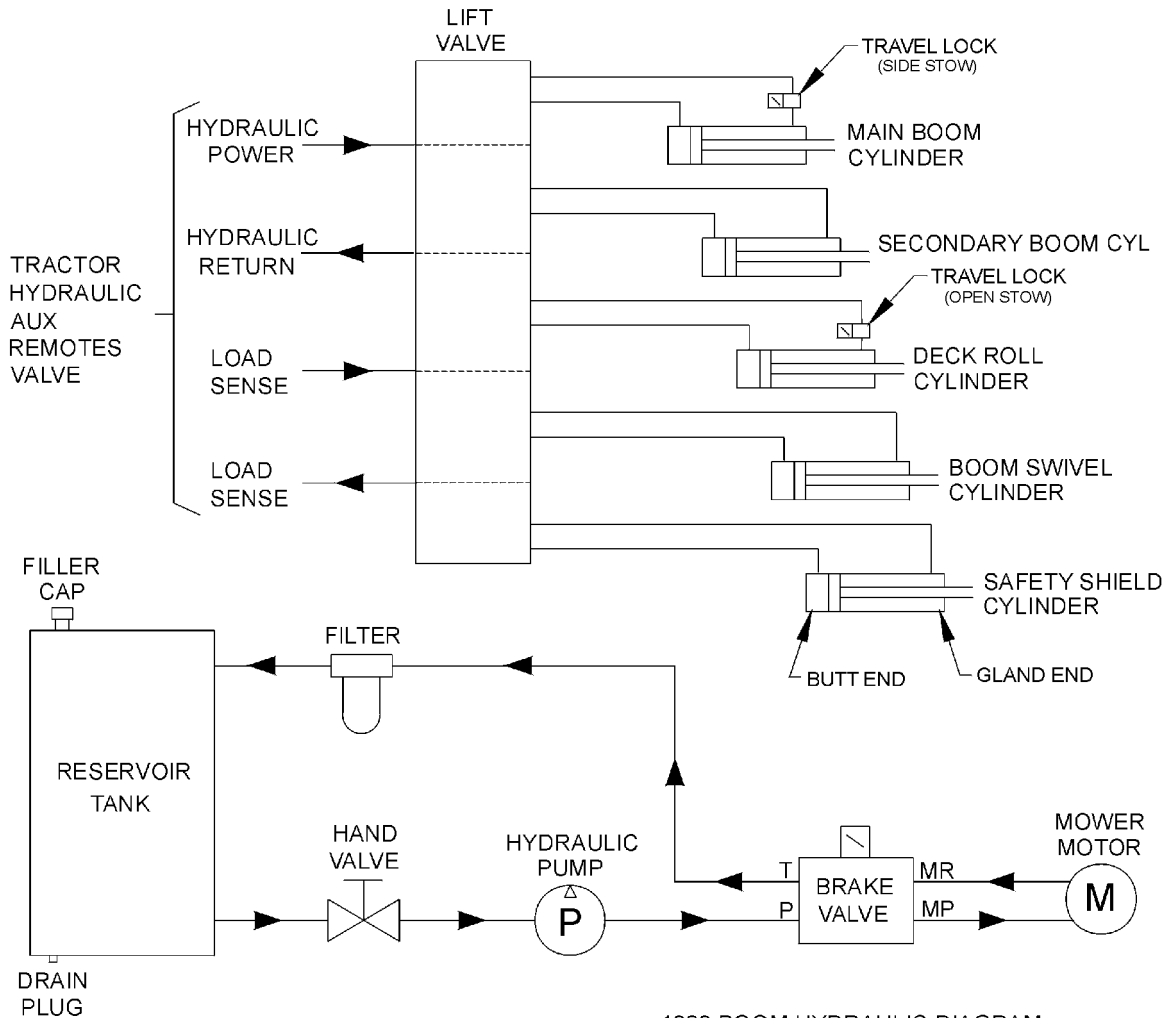

1320 BOOM HYDRAULIC DIAGRAM

## WHEEL WELL HYDRAULIC TANK INSTALLATION

*[Illegible text, likely bleed-through from the reverse side of the page]*

## WHEEL SPACERS

*[Illegible text, likely bleed-through from the reverse side of the page]*







# ASSEMBLY

## OS AXLE BRACE MOUNTING

This diagram illustrates the assembly of the OS Axle Braces. The main assembly shows the boomrest, LH axle brace, and RH axle brace. A separate view shows the boomrest plate being attached to the boomrest.

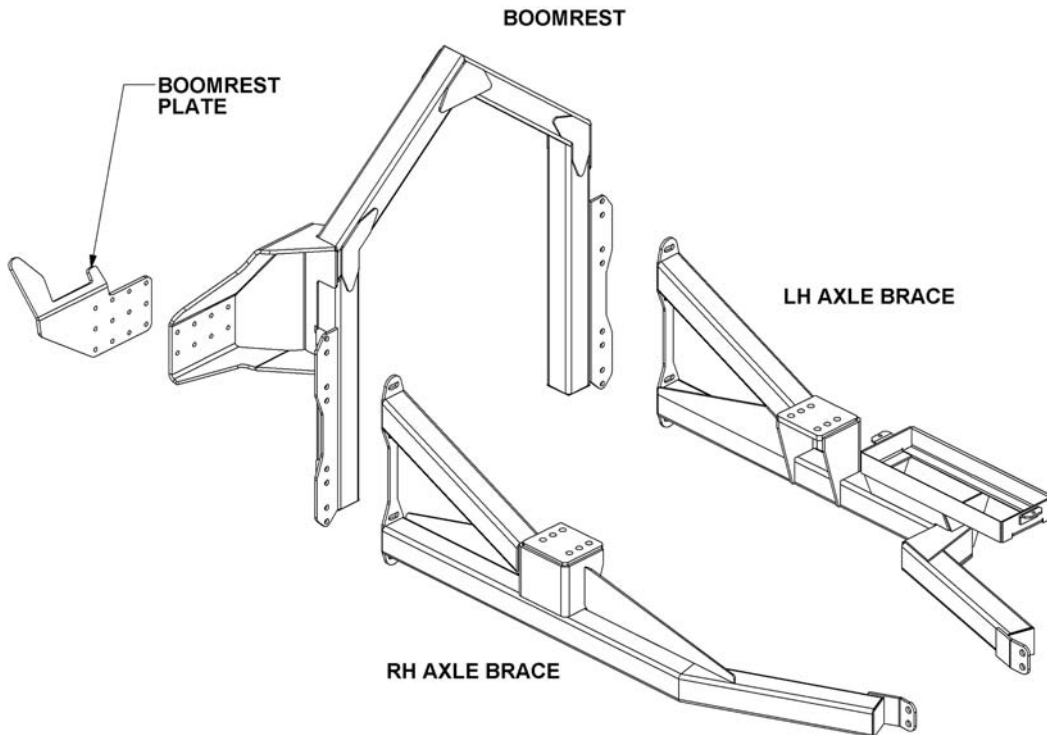

## OS BOOMREST MOUNTING

This diagram illustrates the mounting of the OS Boomrest. It shows the boomrest being attached to the main frame.

## DECK ATTACHMENT

This diagram illustrates the attachment of the Deck. It shows the deck being attached to the main frame.





ASSEMBLY

MAIN BOOM INSTALLATION

- W...
@...
Q...
Q...
Q...

GREASE HINGE PIN ZERKS ON BOOM AFTER ASSEMBLY, ONCE UNDER LOAD WITH BOOM ELEVATED, AND AGAIN AT REST WITH BOOM SUPPORTED. (ASM-C-0013)



# OPERATION SECTION

UJ ^!aa } ÁU^&a } ÁÆ

# OPERATION

## TIGER BOOM MOWER OPERATING INSTRUCTIONS

OPERATION

Va^i^A^O[[{ •Ae^A^ e^ ~ eac^ i^a^A^ a^A^ a^c^ A^ ae^ i^ae^A^ A^ a^i^a^A^ [[ i^i^•EAV@A^O[[{ A^ A^•a^ }^a^A^ A^aeae^O^ A^e  
d^aeq^ i^A^ a^A^ ]^i^ae^A^ca^a^ ~ •A^@ae^•A^ i^A^ae^ a^i^A^ a^\*^A^ A^c^\*^A^ae^A^ a^e^ c^ }^ e^ &^A^ae^ ]^|ae^ae^ }^•EAV@A^[[{ A^e^ a^  
@ae^•Ae^A^~ }^ a^i^a^A^ a^O^ ae^c^ A^ a^ }^ a^\*^A^&ae^ E^ i^ c^&ae^A^a^ i^&ae^ i^•E^ @^|a^•Eae^ a^A^ @^i^A^ae^c^ A^ae^ i^•A^c^  
] i^ c^ae^A^ ]^i^ae^ i^A^ a^A^ ae^•A^ i^A^ i^ c^&ae^ }^ E^Q, ^c^i^E^ [ A^ @^|a^a^ \*^ A^ FEEA^ A^ae^ i^ae^ E^OESSA^ ae^c^ A^~ }^ { ^ }^ o^ae^ a^  
•ae^c^ A^ a^ }^ a^\*^A^&ae^ A^ ~ o^A^A^ a^e^ a^e^ a^a^A^ }^ A^o^A^ }^ a^e^ A^ [[ a^A^ ]^i^ae^ }^ a^e^ ]^ a^a^ }^ A^ae^A^ A^ ~ E

Q^A^ A^c^@^A^ ]^i^ae^ i^q^A^• ]^ ]^•ae^ae^ A^c^ A^a^A^ ]^ ]^ i^a^\*^ae^i^A^ A^c^A^ ]^ c^ }^ a^e^A^ ]^i^ae^ \*^A^e^ ae^a^•A^e^ a^A^ A^c^ae^A^c^i^  
i^ae^ ]^ }^ a^e^A^ i^&ae^ c^ }^ A^c^ A^ }^ i^A^ }^•A^•i^E^ c^o^i^•E^e^ a^ }^ E^e^ a^A^ ]^ ]^ i^c^ A^e^A^ ]^ o^e^ b^ i^a^A^ i^A^ae^ ae^ a^A^ A^ A^c^  
a^ [[ { A^ }^ a^E^ a^e^q^ i^A^ i^A^ae^O^ ]^ ]^ A^ a^b^&ae^O^ A^ ]^ o^e^ ]^i^ae^ A^o^A^ [[ { A^e^ a^A^ae^ae^@^a^A^@^ae^A^A^~ }^ e^e^ a^i^•E^ e^•A^•a^E^  
] ^o^A^ i^A^c^•q^ &^ A^e^A^ a^O^ A^EEA^•o^ A^o^A^ }^ a^E

V@^A^&ae^ }^ A^ A^o^A^ ]^i^ae^ i^q^A^ e^ }^ a^e^ A^ A^•a^ }^ a^A^ A^e^ a^ae^a^ E^e^•d^ &ae^ a^A^ a^ ae^A^ ]^i^ae^ i^•A^ A^o^A^ae^A^e^ a^  
] ]^ ]^i^A^•A^ A^o^A^ [[ { A^e^ a^A^ae^ae^@^a^A^@^ae^E^A^U^c^ i^•A^•A^ }^ a^e^ a^a^A^ A^o^A^ A^&ae^ }^ A^e^A^ c^ }^ a^a^A^ A^a^A^•A^A^e^ A^e  
c^a^~ a^A^ae^A^ A^e^•a^ o^e^ A^c^ ]^ a^e^ a^\*^A^o^A^ ]^i^ae^ }^ A^ A^o^O^ [[ { A^e^ a^A^ae^A^ ]^ o^e^ ]^ a^e^A^ A^e^O^ [[ { E^A^U^ [ ^A^ a^c^ i^•A^ a^e^  
•Q, A^ @^|a^•A^ { [ c^A^A^ A^ }^ @^e^ &^A^a^~ a^e^A^ae^ E^e^ OXOU^ ]^i^ae^ A^o^A^ [[ { A^ }^ a^A^ a^e^ }^ o^e^A^ae^c^ A^~ }^ { ^ }^ o^e^  
] |ae^A^e^ a^A^ A^ ]^ a^A^ ]^i^ae^ }^ a^A^ &^ ]^ a^a^ }^ EAV@A^ ]^i^ae^ i^A^ ~ o^A^A^ae^ a^ae^A^ a^o^c^@^A^ [[ { A^ }^ a^A^ a^e^ a^A^c^ae^q^ i^  
] ]^i^ae^ }^ A^e^ a^A^A^ae^c^ A^ i^ae^ae^•A^ i^A^ A^\*^a^ }^ a^\*^A^ ]^i^ae^ }^ E^A^U^ ]^ ]^i^A^ ]^i^ae^ }^ E^e^ A^e^ae^A^ a^A^ A^o^A^ a^e^ }^ a^e^A^ a^  
@^ ]^ A^ }^•i^A^A^ae^ A^ A^ae^A^e^ a^A^ae^ ae^q^ i^A^•A^ A^o^A^O^ [[ {

**READ AND UNDERSTAND THE ENTIRE OPERATING INSTRUCTIONS AND SAFETY SECTION OF THIS MANUAL AND THE TRACTOR MANUAL BEFORE ATTEMPTING TO USE THE TRACTOR AND IMPLEMENT.** Q^A^ ]^ A^i^ A^ ]^ o^e^ }^ a^i^•ae^ a^A^e^ }^ A^ A^o^A^ }^ d^ &ae^ }^ E^e^ ]^ ae^o^A^ ]^ i^A^ A^ae^•A^e^ o^e^ @^|a^ a^A^A^ a^e^ i^A^ i^A^e  
~ ]^ A^c^ ]^ a^e^ a^e^ }^ E^A^U^ae^ A^e^ ]^•A^A^e^ }^ c^ }^ A^c^ A^e^A^ae^c^ A^ a^ }^•A^e^ a^A^ae^c^ A^ A^••ae^ A^•A^e^ ]^ a^e^ a^a^A^ A^o^A^ a^e^ }^ a^A^e^ a^  
c^@^•A^e^ a^A^ A^o^A^ ]^ ]^ { ^ }^ o^e^ a^A^ae^q^ i^A^ (OPS-U-0001)

ÜÖCÖEAVPÖÖUUVCPÖEÄ a^A^UŠŠUY A^o^A^ ]^ ]^ ]^ ]^ a^\*^A^ae^c^ A^ A^••ae^ A^•A^e^ E^A^U^ i^a^~•A^e^ b^ i^A^ i^  
a^ae^O^ a^e^ A^ &ae^ i^A^ ]^••A^e^A^ A^e^A^ }^ A^c^ A^ ]^ ]^ ]^ ]^ A^o^A^ a^e^ }^ a^\*^A^e^ a^A^e^•d^ &ae^ }^•A^e^ a^A^e^ A^o^  
Üae^c^ A^ A^••ae^ A^•A^e^ E^A^U^ a^e^•A^•A^ [[ a^A^ ]^ { [ ]^ A^ }^•A^ A^e^ ]^ a^A^e^ ae^a^•E^e^O^E^E^A^

**SAFETY INSTRUCTIONS**



**PELIGRO**

Ua^ ]^ A^ A^•A^• ]^•E^ a^ae^ae^ a^ae^ae^ }^ a^ }^ A^ A^a^ ]^ A^ a^e^ a^e^ }^ A^ A^i^ae^ : &ae^ae^  
{ ^ a^ae^ A^ A^•• i^ae^ae^ E^e^O^E^E^A^

**LEA EL INSTRUCTIVO!**



# OPERATION

## 1. OPERATOR REQUIREMENTS

Úæ^Á ] ^íææ } Á -Á@Á } æÁ Á@Á | ^• [ ] • æææ Á -Áæ~ æææ áÁ ] ^íææ | ÉÁÓÁ~ æææ áÁ ] ^íææ | Á@Á ^ææÁæ á  
 ~ } á^• ææ á • Á@Á Á ] | ^ ( ^ ) óææ áÁæææ | Á ] ^íææ | çÁÆ æ } æ Áææ áÁæ Áæ ] ^íææ } &^áÁ Á ] | ^ ( ^ ) óææ áÁæææ |  
 [ ] ^íææ } Áæ áÁæ | Áæ • [ &ææ áÁæææ Á ] æææ • ÉÁÓÁææááá } Áç Á@Á æææ Á ^••æ^•Áæ } ææ^áÁæ Á@Á æ } ææ  
 •æææ Á æ } • Áæ^Áæææ^áÁæ Á@Á Á ] | ^ ( ^ ) óææ áÁæææ | ÉÁÓÁææ^ Áææ Á -Á@Á ] ^íææ } Áæ áÁææÁ •^Á -Á@Á  
 ^~ æ { ^ } óæ Á ] óæ { | ^ç | Á } á^• ç [ áÉæ ] • | óææ Áæ ç | á^áÁæææ^Áæ | Áææ { | ^ç | Á } æææ } É

ÓÁ@Á ] ^íææ | Áææ } [ óÁææÁ@Á æ } æ Áç | Áæ { •^ | ç^• Á | Áæ | ^• Á [ óæ { | ^ç | Á } á^• çæ áÁ@Á ] ^íææ } Á -Á@Á  
 ^~ æ { ^ } óæ Á@Á • [ ] • æææ Á -Á@Á~ ^íçæ [ | Áç Á^ææÁæ áÁæ ] ææ Á@Á æ } æ Éæææ Áæææ • Éææ á  
 [ ] ^íææ } Á • ç & ç } • Áç Á@Á ] ^íææ | É

Úæ^Á ] ^íææ } Á -Á~ æ { ^ } óÁ~ á^• Á@Á@Á@Á ] ^íææ | Á ^æÁæ } | ç^áÁ^• [ ] æÁ ] | ç&ç^Á@~ æ { ^ } óçÚÓÚ  
 ç | Á@Á æ áÁæ } • Á @ } Áæææææ • É ] ^íææ } É^íçæææ • Éææ áÁ^ ] æææ • Á@Á~ æ { ^ } óÁÚÓÚÁæ Áæ • æ } ^áÁæ  
 ] | çæ^Á ] ^íææ | Á ] | ç&ç } Áæ áÁæ &^ á^• Á@Á Á ] | ç^ Áæææ Á ^ææ

### PERSONAL PROTECTIVE EQUIPMENT (PPE)

- ~ Óæ æ^Á ^æÁææææ Á@æ^•
- ~ PæáÁææ
- ~ Úç^ | Á ] ^Áææææ Áç [ ç ^æ
- ~ Ó ] ç^
- ~ P^æææ • Á ] | ç&ç }
- ~ Ó ] •^ Áæææ • Á@ ] çæ^
- ~ Ú^• ] áææ | Á ] Á@ç | Áæ æ \ Áç^ ^ } á^• Á } Á  
 [ ] ^íææ } Áæ } ááá } • É ( OPS-U-0002)

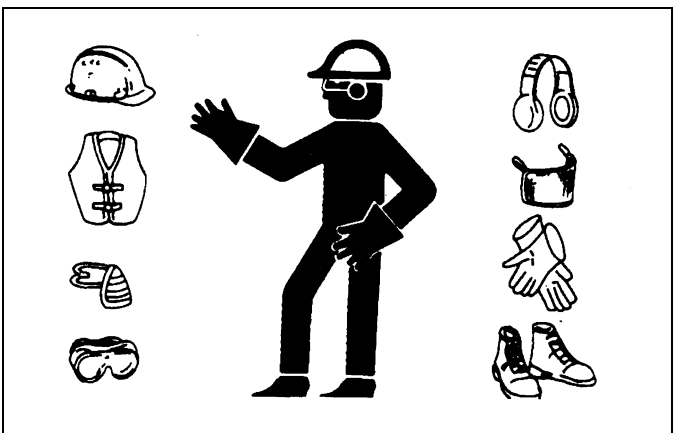

ΠΟΧΟΥΑ^•Áæ~ •^Á | Áæææ ç | Áæ { ^áææ^ Áæç | ^Á | Á @Á ] ^íææ } Á@Á  
 V íæææ | Áææ áÁæ ] | ^ ( ^ ) óææ~ •^ Áæ áÁ æææ ç | Á, ç | Áææ^&óææ Á ] ^íææ | ç  
 æ^íç^••Áææ áÁæ [ | ááæææ } Áææ áÁ@Á^ç | ^Áææ&óç@Á ] ^íææ | ç Áææææ Áæ  
 [ ] ^íææ Á@Á~ æ { ^ } óææ^ ÉÁÓÁç | ^Á ] ^íææ } Á@Á íæææ | Á | Áç ] | ^ ( ^ ) óæ  
 æ Á ] ^íææ | Á } Á | ^• & ç ç } Á | Á ç | ^ç | Áæ } ç | Á ^áæææ } Á ~ óæ } • | ç  
 ææ^ááæææ | | ^••æ } æÁ^ææææ • Áæ^ Áææææ&ç Á -Á@Á ^áææææ } Á@ææ  
 , [ ^ | áÁ@Á á^• Á@Á@Áææææ Áæ Á ] ^íææ Á@Á@Á~ æ { ^ } óææ^ ÉÁΠÓΧÓÚ  
 \ } , ç^ | Áæ ] , Áæ^ [ ] ^Áæ Á ] ^íææ Á@Á~ æ { ^ } óæ @ } Á@Áæææ^íç^••Á |  
 & [ | ááæææ } Áæ Á ] ææ^áÉÁ^íç^• Áæ ç | ^Á | Áææææ Á@Á ] ^íææ | Á | Á ç |  
 &^ | áÁ^• | óæ Á@Á ] ^íææ | Áæ Á } á^• Á@Á ç | ^ } &^ Áæ~ •^ Á | Áæææ ç | Áæ

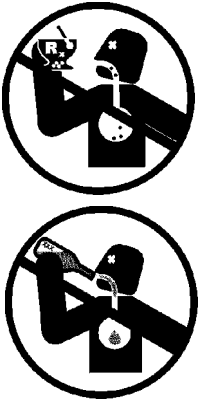

Ó ] { U ] ^íææ } Á ] & ç } Áæ

OPERATION



# OPERATION



P^ç^A] ^iæ^A@^V:æd |Aæ åAT [, ^i^A^] åA åQ ~ ^æ AUUUQU] ^iæ |  
 Ú: [ ç^æ^AÚd ~ &c |^D^ |AÓæAç |A: ^ç^} çå b: ^i^ { |A àb&ç^Aç[ , } A^ [ {  
 \* | [ ^ } åA |A: [ { |A ç^ | @æåAç { å \* EAU] |A [ , å \* ÅA [ | ^ ^ . |A |A æ . ^ . à  
 æ^A åç |A EEA^ ç^ PÓT ÈD



## 2.3 Tractor Lighting and SMV Emblem

Q@^A:æd |A å|A^A] ^iæ åA^æA |A:æ^A^A } Åæ  
 ] ~ à|A^ [ æ, æ ÅåA ~ . ç^A^A ~ å ] ^åA åç | [ ] ^i  
 , æ } å \* Åå çå \* Åæ å ÅåU [ , Å [ çå \* Å^ ç^ |A ÇT XD  
 ^ { à | ^ |A ç^ ç^ ^ Å^ |A æ | ^ çå å |A^ [ { Å@^A^æA ~  
 @^A } åEAT [ . ç^æd | ç^ Å@æ^Aåå^ | ^ } ç^ çå \* Å |  
 [ ] ^iæå \* Åæ å Åçæ . ] [ | çå \* Åå çå \* EAU^A |A ç@  
 dæd |A [ ] ^iæ | ç^ Å ( çå ~ çå |A ^ . å \* Åç@ Åçæd | ç  
 |å @A , å&çå åA ] ^iæå \* Å@ Å | } Åå } ç^ E

OPS-B-0017



OPERATION

Ó [ { U ] ^iæ } Å^ & ç } Å E







# OPERATION

## 4. STARTING THE TRACTOR

OPERATION

V@Á ] ^\æ |Á · ·Á@Æ ^Áæ [ ] | ^Á } á ^\ · æ áä \* Á · Á@Á |æ { ^ } &ç } Éæ áÁ ] ^\ææ } æÁ · ^Á · Áæ |æ ç |Á [ d | · Á ^ | ^Á æ ç \* Á@Á æ ç | ÉÁ ^ç ã, Á@Á æ ç | Á ] ^\æ | q Á æ ~ æÁæ áÁ [ · ^ |ææ Áæ ç | á ^ á á ^ æ ^ Á | Á æ ç | Á ] ^\ææ } / · d ~ &ç } · Á ^ á ^ á È

Ö · ^ } æ Á / æ ç | Á [ d | · K

- " S | æ Á @ Á } æ } Á ^ · æ @Á
- " S | æ Á @ Á } \* ä ^ Á @ Á ^ Á } d |
- " S | æ Á @ Á @ á æ | æ Á } d | | Á ^ç ^ · Á
- " S | æ Á @ Á æ @ Á } d | | Á ^ç ^
- " S | æ Á @ Á | æ ^ Á ^ á æ æ á Á ^ æ @Á
- " S | æ Á @ Á V U Á } d | | Á
- " S | æ Á @ Á | á | ä Á æ ç | d | | Á ^ç ^
- " S | æ Á @ Á [ { Á ] ^\ææ \* Á } d | | Á ^ · æ Á | Á ç ^ Á æ | D

Ö ^ | ^Á æ ç \* Á @ Á æ ç | Á } · ^ Á @ Á | | | , ä \* Á Á

- " Ö [ ] á ~ &ç | Á | Á È æ ç | ^\ææ } / · ^ &ç } Á æ á Á ^ç æ Á æ | á ä \* Á Á @ Á æ ç | Á ] ^\æ | q Á æ ~ æ Á
- " T æ Á ^ Á ^ Á æ ç á á · É á ç | á · É æ á á ç | Á æ ^ ç Á · Á ^ Á ^ Á & ^ | ^ / Á | æ È
- " V @ Á æ ä ä \* Á | æ ^ Á } É
- " V @ Á æ ç | Á æ { ä · ä } Á ^ç ^ · Á / Á æ | Á | Á ^ d æ È
- " V @ Á [ { Á ] ^\ææ \* Á } d | | Á ^ Á Á @ Á ^ d æ æ á Á ^ Á [ · ä } È
- " V @ Á V U Á } d | | Á ^ç ^ Á ^ Á ^ \* æ ^ á È
- " V @ Á @ á æ | æ Á { [ ç Á } d | | Á ^ç ^ · Á ^ Á Á @ Á ^ d æ Á [ · ä } É

Ü ^ Á | Á Á @ Á æ ç | Á , } ^ | q Á æ ~ æ Á | Á æ ç | Á æ ç \* Á | &á ^ Á · É Á | ^ Á æ ç | Á @ Á ^ Á æ á Á æ á á á ^ Á Á Á @ Á æ ç | Á ] ^\æ | q Á ^ æ Á ^ç ^ Á æ · Á @ Á } æ } Á, æ @ Á ^ Á @ | Á & æ \* Á @ Á æ ç | Á | ^ [ æ Ö Á @ Á æ ç | Á } \* ä ^ Á } } ä \* É æ | á Á æ ç ^ } æ ç | æ ç | Á @ Á æ ç | Á æ { ä · ä } Á | Á ^ç ^ Á ^ á á } æ á Á ^ç ^ Á ^ ç | Á [ ç { ^ } É OPS-B- 0003



Á ^ç ^ Á ^ } Á @ Á / æ ç | Á } \* ä ^ Á Á æ ç | Á ^ Á Á ^ Á ^ á ä \* Á | Á æ ç ~ Á æ ^ Á ^ } d æ } É Á @ Á ^ç ^ · Á { Á ^ Á æ Á ^ Á æ æ á [ ^ Á Á | Á @ æ ç | Á ^ç ^ Á ^



Ü ç é ç æ ç | Á } | Á @ } Á | | ^ | Á ^ æ á Á Á @ Á / æ ç | Á ^ æ Á ^ Á æ ç \* Á æ ç | Á Á ^ æ Á æ Á ^ · | ç Á Á | Á | Á ^ æ Á ^ á Á @ Á / æ ç | Á ] ^\æ | { æ ~ æ Á | Á | | ^ Á æ ç \* Á · d ~ &ç } · É Á ^ç ^ Á



Ö [ { U ] ^\ææ } Á ^ &ç } Á È

# OPERATION

OPERATION

## 5. CONNECTING ATTACHING HEADS TO THE BOOM

FÉÁÚ cæóÀ Æææ&@ \* Ác@ Á æç | óÀ:ææ ^ ÇDÁ Ác@ÁÀ [ [ ÇD  
 ~ • ä \* Á ä Ç Dæ áÁcæá, æ^ÉÁ^ Çææ&@c@ & | ä á^Á Ác@  
 ] æç | óÀ:ææ ^ ÇDÁ • ä \* Á ä Ç Dæ áÁ [ | Á ä • É

ÇÁV @ } Áææ&@c@ ÁÀ [ \* | \* Ç DÁ Ác@Á [ , | ÇDÁ • ä \* Á ä Ç D  
 æ áÁcæá, æ^É

HÉV ^ ÁæÁQ ä áÁ Á | ^ Ác@ ÁÀ [ [ ÇDÁ [ } Á Ác@Á [ , | ÇDÉ  
 Q • Á^ Ác@Á ] | Á ä Ç Dæ [ ~ @ Ác@Á ) áÁ Ác@Á [ [ Á æ áÁc@  
 { [ , | Áææ&@, æc@æá, æ^É

| ÉV @ } Áæá } Ác@ÁÀ [ \* | \* Ç Dæ áÁc@Á æç | óÀ:ææ ^ ÇDÁææ&@  
 , æÇ ä Ç Dæ áÁcæá, æ^É

Í Éæ æç Á æ Á ^ | ÁæÁÀ | ç É ~ ç É æ áÁ ä • Áæ Áæ @ } ^ áÁ Á  
 | ^ & [ { ^ } á á Á Á | ^ ^ ÉOPS-B- 0004\_D

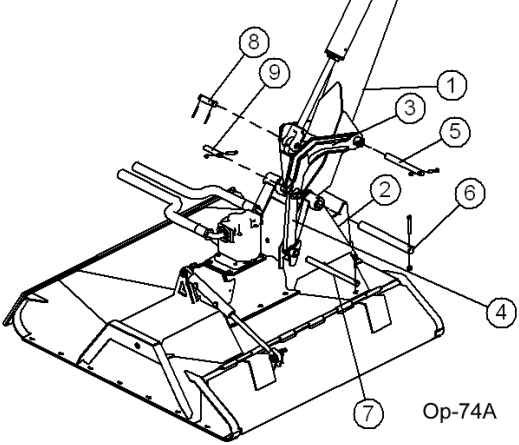

Çç [ æÁ& } ææóÁ æc@Q ç ^ | ææ Áæ & | ä ä \* Ác@ áææ | æç ä çæ \ • É ] { | • É [ ç | É ç æ ç ^ Áæ ä  
 @ • ^ Á& } ^ & ç } • ÉÁÚ | æ ç ^ Ác@ áææ | æç | ^ • ~ | ^ Áæ ^ | ^ Á | ^ | | ä \* Á æ ç } æ & Á | Á ^ } æ • É  
 W • ^ Á [ ç ^ Áæ ä Á ^ Á | | ç & ç } Á @ } Á | ç æ ä \* Á ç Á& [ ] [ ^ ] ç ÉÁÓ [ ] ææóÁ æc@Q ç ^ | ææ  
 [ | Á ^ æ Áææ Áææ • ^ Á | ä ~ • Á ç | Á [ { Á ~ | } • Á | Á & æ ä ä \* ÉÁÜÉH D



Ö | Á [ ç ] | ^ æ Ác@ ÁÓ ~ ä { ^ } ç | æç | ææ | æç ä ç | Á ^ | Á ^ æ ä \* ÉÁÚ ä  
 æ áÁ ^ | Áæ Á ç [ ] | • æ ^ Áæ áÁc@ ä Á | ^ • ^ } & Á& | ä Á | ^ • ^ } çæææ ææ ÉÁÓ  
 } [ Á& @ & Á | Á ^ æ • Á æç [ ~ | Áæ ä Áæ Á æ ç ] ^ • • | ^ Á ä ä d ^ æ • Á | [ {  
 á | æ æ • Áæ Ác@ Á ä ^ Á& | ä Á ^ | ^ d æ Ác@ Á | ä ä áÁæ • ^ Áæ • ^ Áæ æ ^ Áæ æ  
 ä ä \* Á æ \* Á æ \* Á ^ | Áæ Á& @ & Á | Áæ Q • ^ Á æ ÉÁÚWÁc@Á } æç Ö Ç Ö Ç Ö  
 U Ç Ç Áæ Á ^ [ ç ^ Áæ | ææ | æç | ^ • ~ | ^ ÉÁV ^ æ ä ä ç [ ] ^ | ^ d ææ | Á [ ç ^ É  
 • æ ç Á | æ • Áæ æ áÁ • ^ ÁÓ ææ ä | æáÁ Á& @ & Á | Á ç æ ^ } & Á ^ Á æ ä • ÉÁÜ  
 ^ [ ~ Á • ] ^ Áæ æ ÉÁÜ Ö T U X Ö Ác@ Á P U U Ö Áæ áÁc@æ ^ Áæ • ç áÁææ Ö æ | É  
 Ç Á ä Á [ ^ Á ^ | ^ d æ Ác@ Á | ä ÉÁÜ Ác@ Áæ | Áæ | Á ^ æ áÁ { ^ áææ | Áæ Áæ  
 ] @ • ææ Á [ ] , | á ^ ææ Áæ ä Á | ä | á Áæ Ác@ Á | | & á ^ | ^ ÉÁÜÉH D



## 6. PRE-OPERATION INSPECTION AND SERVICE

Ó ç | ^ Áæ æ & Á • ^ ÉÁÚ | Á É | | ææ } Áæ • | ^ & ç } Áæ ä Á | ç æ Á Ác@ Áæ ] | ^ | ^ } óæ ä Á cæ d | Á ^ • óæ Á | ^ | | ^ áÉ  
 V ç Áæ & | á ^ Á | ç ^ Áæ ç } æ & Áæ ä Á & @ á | á Á | á æææ } Éá • | ^ & ç \* Ác@æç | Áæ ç Áæ ç æ Áæ Áæ ~ ä ] á  
 æ áÁ ^ } & ç } æ Éæ æ Á | ^ | | ä \* Á ^ á á Á ^ } ææ ÉÁÜ Á P U V Á | | ææ Ác@ Á } æ Ác@ Á | Á É | | ææ } Áæ • | ^ & ç }  
 | ^ ç æ ç Áæ ^ Á& | ä äæ } Áæ ^ & ç \* Á æ Á | | ææ } ÉÁÚ | ^ | | Á ^ } ææ Áæ ä Á ^ | ææ ^ | ç | Áæ æ á Áæ æ áÁ æ áÁ ä \*  
 ] æ ç Á Á [ ] Áæ Á | ç æ Áæ ÉÁÜ Á | ^ | | ä \* Áæ ç | | ^ \* @ | Á É | | ææ } Áæ • | ^ & ç } Áæ ä Á | ç æ Áæ ææ æ | Áæ [ , } Áæ ^  
 æ áÁ ^ } ææ Á& | • Éæ Áæ Áæ | æ á ÉÁÜOPS-U-0029

Ö [ { U ] | ææ } Á ^ & ç } Á É

# OPERATION

OPERATION

**WARNING**

U^i q a a b e q A a q . ^ & o A e q A [ c a \* A ] a e o A f i A , ^ a e A a q a A i ^ | a e A , @ } ^ & . . a e A a o a e o q i a ^ a A i c a e A a e o E a S [ i A i A [ i . ^ A a e o } ^ i . E a [ i ] [ i A a i \ ^ } A ] a e o E a q a A a e ^ A i A [ i . ^ A a e q \* E a T a e ^ A ^ i A e q A ] a . A o e q a e a e o \* A o a a , a e E a U i q ^ . a b i ^ A e a A & i A i { A [ o i a e a q a \* A o e { a e o ^ a q A [ i a [ i \ a \* A i a ^ i E a U O E F E D

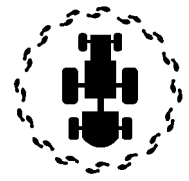

**DANGER**

O q i U a e c A U o i a . E a o ^ a a . A e q a A U a e c A a ^ c a e . a q & i a q \* A q ^ o y [ c ] a a a A q D E a o A O ^ i & q i . E a o e a q A O ^ a a . E a U e ^ i A O ^ a a . E a O ^ a a i c U o i a . E a U U a q o ^ i a q a o i a . E a q a a U i c a e a e ^ A O [ i A U o i a . A q ^ i a a ^ . ^ a a e q a A q a e a a A q A [ i a A [ i \ a \* A q } a a q } E a O q i A e c A a ^ c a e . A . @ ^ i a A a q . ] ^ & o a A e a e ^ | i a e a e o a e a e A i A a . a q \* A i A i \ ^ } & i { [ i ] ^ } o E a T a . a q \* E a i \ ^ } E [ i A a [ i ] a e { . A ^ . o a A A } | a e a a e a } & A i A a ^ & A o A [ . . a a q A a b i ^ A i A e a e o + [ { A o [ , } A a b o E a } a e \* i { ^ } e a i A i a e a A q } a e e a U O T E D

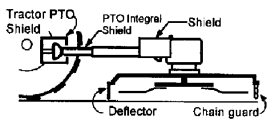

**6.1 Tractor Pre-Operation Inspection/Service**

U ^ a i A q A o A c a e q i A ] ^ i a e q i q A e q a e q A ^ . ^ i A e e q [ ] i c A i ^ E i ^ i a e q } A q . ^ & q } A e q a A e & o a ^ i a . ^ i c a e A a q a i ^ + [ i a A a e q i a q \* A q i a o { a e ^ a e c i ^ i . A i ^ e q { { ^ } a e a q } . E a V o A t i i l , q \* a e A i { ^ A ^ A o a e { . A o e A ^ ^ a ^ a e a A i c a e A a q a q . ] ^ & q } K



- " V a ^ A q } a a q } E a q i . ^ . ^ i a
- " Y @ ^ i A ^ \* A i | o A
- " U e ^ i q \* A q \ a e ^
- " U V U A o i a A
- " U T X A a } A e A i a q a e a A q a e i a
- " V i a e q i q A a o a e ^ A i a e q a e a A ^ } & q } a e
- " V i a e q i A U a e a i o e a e A [ i a A q } a a q } A
- " V i a e q i A U U U U a e a e A [ i a A q } a a q }
- " U U U U a e a e A o A a e a a A [ . a a q }
- " E [ A i a e q i A q a e a e . A
- " U a a e q i A i ^ A ^ A a i a i A
- " O ) \* q ^ A q a c ^ i A e q a A q } a a q }
- " O ) \* q ^ A q [ i a e o i c ^ i A e q a A q } a a q } A
- " U [ , ^ i A i a e a A q a e a c ^ i A
- " U [ , ^ i A e ^ i q \* A q a e a c ^ i A
- " O ^ A q } a a q } a e a A q c ^ i A
- " U ^ a e } o i a i a e a q } a e a i A a ^ A [ q o
- " O a A c ^ i A q } a a q } A O P S - U - 0 0 3 0

Op-13

O i { U ] ^ i a e q } A i ^ & q } A i E e



# OPERATION

# OPERATION



Ú|ãç^Á@á|æ|ãÁ|••|^Á|ã|Á|ã|ã \*ã ~^ã ãã}ã &Á|Á^|ãÁ [ |ã } Á@ÁQ ]|^ { }ã Ú|ãã^Á@Á [ , ^|Á^ããÁ }Á@Á| [ ~ }ãÁ|Á^&^|^Á~]] [ |ãáÁ }Á [ &•Á|Áã}ã •ãã^)^ \*ã^ã @ÁÚVUãã }ãã : }Á -Á@Á } \*ã^ã~ •ãã}ã |Á@Á } d [ |Áç^Á|•Á|Á |ã •ãÁãç^ÁãÁ^ã •ãÁãç^Á|••|^Á|ã|Á|ã|ããã \*ã ~^ã ãã}ã &Á|Á^|ãÁ [ |ã } Á@ÁQ ]|^ { }ã



Ð^ç^ÁÁ^ã^Á@Á [ , ^|Á^ãã }ã^ãÁ @^Á@Á@ãÁÁ Á Á@Áã^ã ] [ •ãã ] ËÁV@Á [ , ^|ÁÁ |ãÁã|ãã }ã \*Á^ã ~ •ãã Á^Áã }ã ]^ Á^ Á @ {ã @ããç^Á }ã }ãÁ }ãÁ@Á [ , ^| Á@ÁQ ]|^ { }ã



OUUT ÆJT ÆJUOT OSY

- " Q. ]^&Á }ãã }Á -Áãã{ Á&ã } Á |ã{ }c
- " Q. ]^ÁÁ }ãã }Á -Áãã{ Á&ã } Á |ã{ }
- " Q. ]^ÁÁ }ãã }Á -Áãã{ Á&ã } Á |ã{ }
- " Q. ]^ÁÁ }ãã }Á -Áãã{ Á&ã } Á |ã{ }
- " Q. ]^ÁÁ }ãã }Á -Áãã{ Á&ã } Á |ã{ }
- " Q. ]^ÁÁ }ãã }Á -Áãã{ Á&ã } Á |ã{ }



Ð^ç^ÁÁ^ã^Á@Á [ , ^|Á^ãã }ã^ãÁ @^Á@Á@ãÁÁ Á Á@Áã^ã ] [ •ãã ] ËÁV@Á [ , ^|ÁÁ |ãÁã|ãã }ã \*Á^ã ~ •ãã Á^Áã }ã ]^ Á^ Á @ {ã @ããç^Á }ã }ãÁ }ãÁ@Á [ , ^| Á@ÁQ ]|^ { }ã

PYOUÇVSOÄSQ OÄD UJUOØVØÞ

- " Q. ]^&Á }ãã }Á -Áãã{ Á&ã } Á |ã{ }
- " Q. ]^ÁÁ }ãã }Á -Áãã{ Á&ã } Á |ã{ }
- " Q. ]^ÁÁ }ãã }Á -Áãã{ Á&ã } Á |ã{ }
- " Q. ]^ÁÁ }ãã }Á -Áãã{ Á&ã } Á |ã{ }

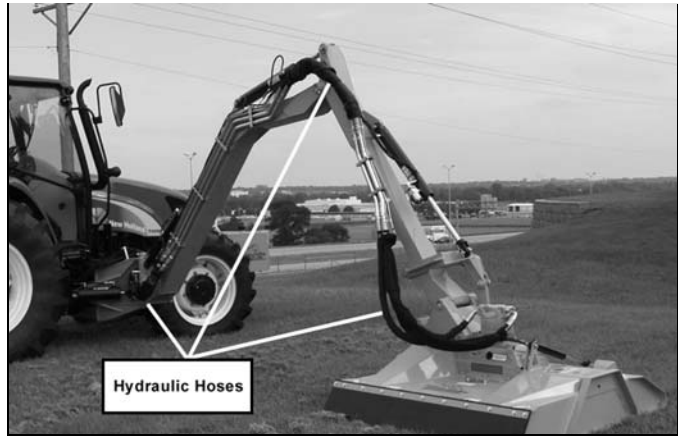



# OPERATION

OPERATION

ÜUVOEY'P ÖÖÖÄP ÜÜÖÖVWÞ

- " Q. ] ^ & ö | æ ð ^ • Æ ð ð Æ | æ ð Æ | [ | ö Ä | Ä | [ • ^ ] • • • Ä æ ð ð Ä ç & • • ð ^ Ä ^ æ Æ Ü [ æ Æ Ä Ä € Æ Ä Ä æ ð Ä † | Æ @ & ä \* Ä æ ð Æ Ü ^ | æ Æ Æ æ æ ð ð Ä [ ] Æ æ ð ð Ä ä • ä \* Æ | æ ð ð • Æ Æ { | | ö Ä ö Ä Ä { æ æ Ä | æ ð Æ æ æ & É
- " Ö. ) ~ | ^ Ä [ † | Æ | | ö Ä ð ð ð • ö Æ ^ Ä @ ) ^ ð Ä Ä @ Ä ] | [ ] | æ Ä | ^ É
- " Ö. ) ~ | ^ Ä ~ à à | Æ ^ † & † • Æ ^ Ä Ä [ • æ ] Ä ä Ä } [ ö æ æ æ ð ð Ä ^ | æ Ä [ ] Æ [ \ ^ ] Æ ä Ä { ä • ä \* Ä ^ & ç } • Ä { ^ ä æ | É
- " Ö. ) ~ | ^ Ä @ ä ä æ | æ Ä ^ • Æ ^ Ä | [ ] ^ | | Ä } } ^ & ç ä Ä † Ä @ Ä @ ä ä æ | æ Ä [ † | Æ @ & Ä | Ä @ ä ä æ | æ Ä | æ • Ä | } \* Ä • • Ä ä Ä ä \* • Æ Ü Ä Ü V Ä • Ä Ä [ ^ | Ä @ ä ä Ä & @ & Ä | Ä ä ä ä • Æ ^ ^ æ ð ð & Ä [ Ä @ æ Ä æ ^ Ä | Æ æ ä à | æ ä Ä & @ & Ä | Ä @ ä ä æ | æ Ä ä ä • É
- " Q. ] ^ & ö | æ | ä ä } Ä Ä & Ä | æ Ä @ ^ • Ä ä ä ä, æ Æ OPS-B- 0025



**WARNING**

O [ Ä [ ö ] ~ ö @ ä ä • Ä | Ä ^ ö } ä | Ä [ , ^ | Ä ^ & • Æ Ö | æ ð Æ | Ä [ æ & ç ä Ä • | ç ä Ä ^ ä ~ • Ä ä | ^ Ä | Ä ç ^ Ä ä æ æ Ä æ æ Ä } ç Ä Ä | [ ç ] Ä @ Ä ç ] ] ^ ä æ ð ð @ Æ ^ & • Æ ^ Ä ^ & | ^ | Æ | [ & ^ ä Ä ] Æ

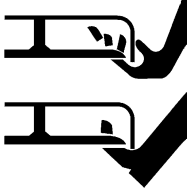

**DANGER**

Ö Ä Ü æ ç Ä Ü @ | ä • Æ Ö ~ æ ä • Ä æ ä Ä | @ | Ä • æ ç Ä ä ç æ • Ä & ä ä \* Ä ç ~ ö } [ ö | ä æ ä Ä ç Ä Ä Ö ^ † & † | • Æ Ü ç ^ | Ä Ö ~ æ ä • Ä æ ä Ä Ö æ ä | ç Ä Ü @ | ä • Ä | ~ • ö ä ^ Ä • ^ ä Ä æ ä Ä | æ æ æ ^ ä Ä ä Ä [ | ä , [ | ä \* Ä | } ä ä } Æ Ö Ä æ ç Ä ç Ä • Ä @ ~ | ä Ä Ä • ] ^ & ç ä ä æ ~ | | Ä ç æ ö æ æ Ä | Ä ä • ä \* [ | Ä | \ ^ ] Ä { ] [ ] ^ ö Æ ä ä • ä \* Æ | \ ^ ] Ä | Ä [ ] | Ä { • Ä ~ ö ä ^ Ä | æ ä ä Ä } & Ä Ä Ä ä ~ & @ Ä | • • æ ä ç Ä Ä ä | Ä | Ä ^ æ ç Ä | { Ä @ [ , } Ä ä ä & ç Ä } æ \* | ^ ^ | Ä | Ä | æ Æ | } æ ç Ä

Ö [ { U ] ^ | æ } Ä ^ & ç } Ä Ä |



# OPERATION

OPERATION

## OPERATION

- 1. Before starting the engine, check the oil level and the fuel level. The oil level should be between the "MIN" and "MAX" marks on the dipstick. The fuel tank should be full.
- 2. Make sure the PTO lever is in the "OFF" position before starting the engine.
- 3. Before starting the engine, make sure the PTO lever is in the "OFF" position.
- 4. Before starting the engine, make sure the PTO lever is in the "OFF" position.
- 5. Before starting the engine, make sure the PTO lever is in the "OFF" position.
- 6. Before starting the engine, make sure the PTO lever is in the "OFF" position.
- 7. Before starting the engine, make sure the PTO lever is in the "OFF" position.
- 8. Before starting the engine, make sure the PTO lever is in the "OFF" position.
- 9. Before starting the engine, make sure the PTO lever is in the "OFF" position.
- 10. Before starting the engine, make sure the PTO lever is in the "OFF" position.



Op-80\_A



Op-82\_A



Before starting the engine, make sure the PTO lever is in the "OFF" position. The PTO lever is located on the side of the generator. It should be in the "OFF" position before starting the engine. If the PTO lever is in the "ON" position, the generator will not start.



Before starting the engine, make sure the PTO lever is in the "OFF" position. The PTO lever is located on the side of the generator. It should be in the "OFF" position before starting the engine. If the PTO lever is in the "ON" position, the generator will not start.

© 2013

Alamo Group Inc.

# OPERATION

OPERATION

## 6.3 Cutting Component Inspection

OPS-U-0031

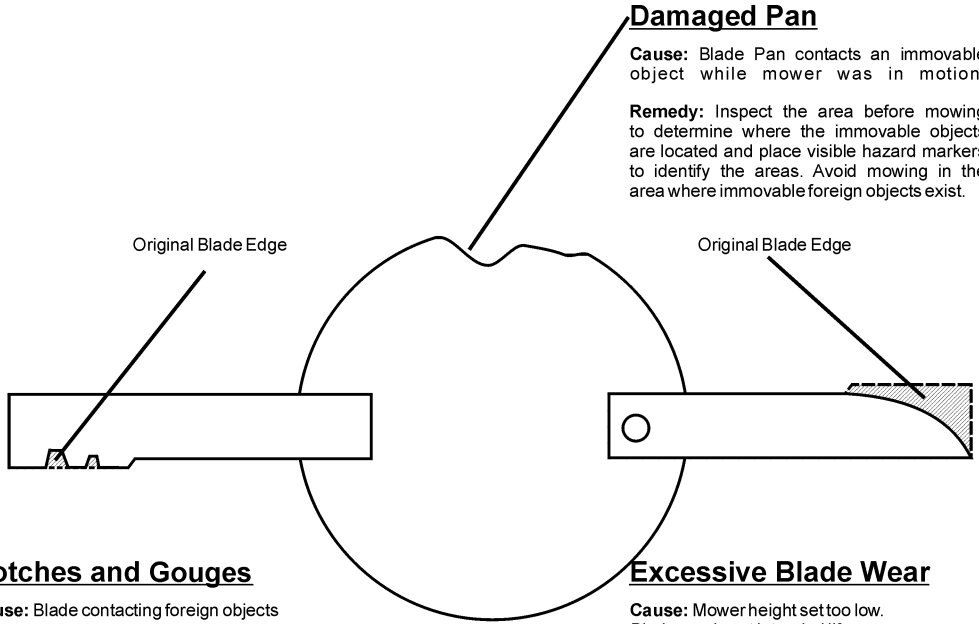

### Damaged Pan

**Cause:** Blade Pan contacts an immovable object while mower was in motion.  
**Remedy:** Inspect the area before mowing to determine where the immovable objects are located and place visible hazard markers to identify the areas. Avoid mowing in the area where immovable foreign objects exist.

### Notches and Gouges

**Cause:** Blade contacting foreign objects  
**Remedy:** Inspect the area to be mowed and remove foreign objects that could cause damage to the blades

### Excessive Blade Wear

**Cause:** Mower height set too low. Blade used past intended life.  
**Remedy:** Replace blades more often. Adjust mower height for mowing Conditions to eliminate blade-to-ground contact

Op-22



**DANGER** ...

- " ...
- " ...
- " ...
- " ...
- " ...

OPS-U-0032

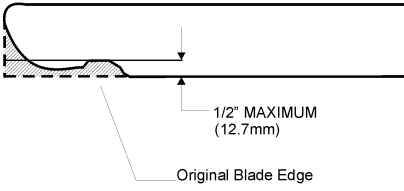

**NOTE:**  
 Replace Blades in pairs after no more than 1/2" (12.7mm) wear  
 Op-23

U] ^! aaj } A^&ca } A-EI

# OPERATION

## Tractor PRE-OPERATION Inspection



Mower ID# \_\_\_\_\_ Make \_\_\_\_\_

Date: \_\_\_\_\_ Shift \_\_\_\_\_



Before conducting the inspection, make sure the tractor engine is off, all rotation has stopped and the tractor is in park with the parking brake engaged. Make sure the mower is resting on the ground or securely blocked up and all hydraulic pressure has been relieved.

**OPERATION**

Item	Condition at Start of Shift	Specific Comments if not O.K.
The flashing lights function properly		
The SMV Sign is clean and visible		
The tires are in good condition with proper pressure		
The wheel lug bolts are tight		
The tractor brakes are in good condition		
The steering linkage is in good condition		
There are no visible oil leaks		
The hydraulic controls function properly		
The ROPS or ROBS Cab is in good condition		
The seatbelt is in place and in good condition		
The 3-point hitch is in good condition		
The drawbar pins are securely in place		
The PTO master shield is in place		
The engine oil level is full		
The brake fluid level is full		
The power steering fluid level is full		
The fuel level is adequate		
The engine coolant fluid level is full		
The radiator is free of debris		
The air filter is in good condition		

Operator's Signature: \_\_\_\_\_

**DO NOT OPERATE an UNSAFE TRACTOR or MOWER**

V@AQ•^&ā } AQ ;{ Á æ Á^Á^Λ^ Á } |ææ^áÁ!Áccā&| ā•È

Ó[ {

U ] ^!æā } Á^&ā } ÁÈï

# OPERATION

## Boom PRE-OPERATION Inspection



Mower ID# \_\_\_\_\_ Make \_\_\_\_\_  
 Date: \_\_\_\_\_ Shift \_\_\_\_\_



Before conducting the inspection, make sure the tractor engine is off, all rotation has stopped and the tractor is in park with the parking brake engaged. Make sure the mower is resting on the ground or securely blocked up and all hydraulic pressure has been relieved.

**Table 1:**

Item	Condition at Start of Shift	Specific Comments if not O.K.
The Operator's Manual is in the tractor		
All safety decals are in place and legible		
The mounting frame bolts are in place and tight		
The boom connection bolts & pins are tight		
There are no cracks in boom		
The hydraulic cylinders pins are tight		
The hydraulic pump hose connections are tight		
The hydraulic valve controls function properly		
There are no leaking or damaged hoses		
The hydraulic oil level is full		
There is no evidence of hydraulic leaks		
The blades are not chipped, cracked or bent		
The blade bolts are tight		
The deflectors are in place and in good condition		
The boom shields are in place and in good condition		
The skid shoes are in good condition and tight		
There are no cracks or holes in boom deck		
The hydraulic motor mounting bolts are tight		
The boom head spindle housing is tight and lubricated		

Operator's Signature: \_\_\_\_\_

**DO NOT OPERATE an UNSAFE TRACTOR or MOWER**

**OPERATION**

# OPERATION

## Cable Controlled Mowers

OPERATION

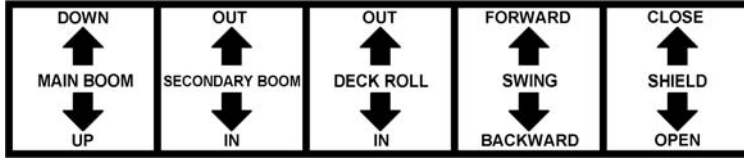

OPERATION

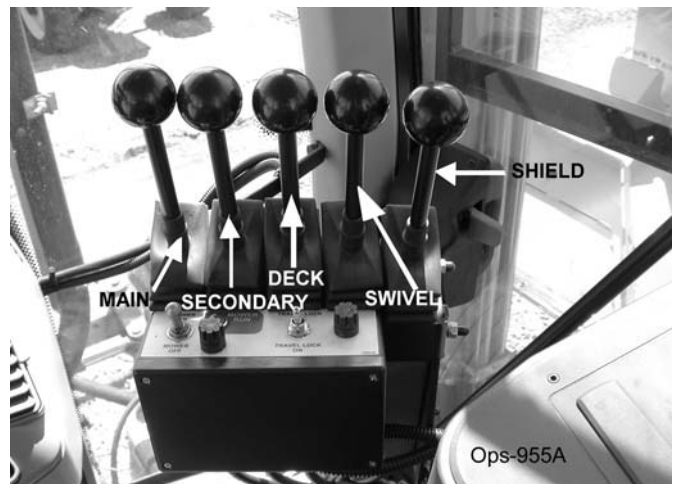
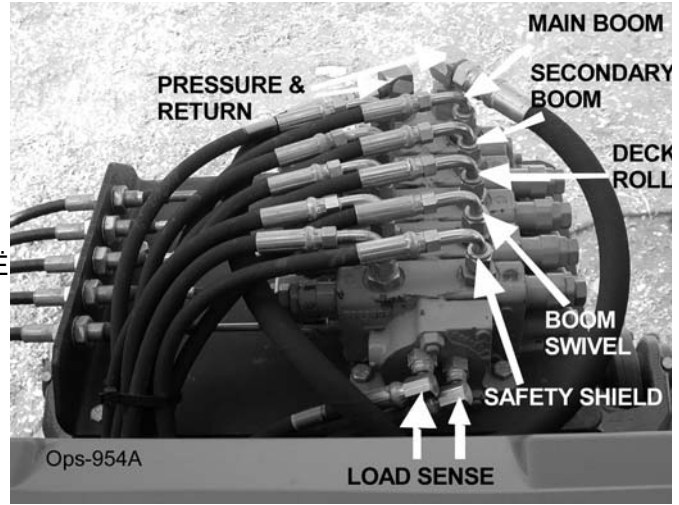

OPERATION

# OPERATION

OPERATION

## 6.4 Switchbox

V@ÁÛæc ÁÛ@|áÁç^iÁ] ^} • Áæ áÁ&| [ • ^ • Á@Á @|á  
 || &æ áÁ} Á@Á[ ] ð Á@Á& æ! Á@æÉY @) Á [ çá \*  
 æÁ! Á ^æ Á@Á! [ ~ } áÉæ, æ • Á@æ ^ Á@Á @|áÁæ Á@  
 &| • ^ áÁ] [ • æá } ÉY @) Á [ , á \* Áæ Á@Á! ~ • @|! Áæ  
 ç^ • Áæ [ ç^ Á! [ ~ } áÁç^ | Á@Á @|áÁ æ Á^ Á] ^} ^ á  
 †! Áæ á! Á& æá \* ÉÛ^æáÁæ áÁ] || , Á@Á æ} á \* Á} }  
 ç Á^ &æ Á @ , } Á^ || , ÉÖ [ Á [ ç^ } Á@Á& æ! Á@æ  
 á ç Á æ! æáÁæ \* ^! Á@æ Á ^ Áæ ^ ç! É

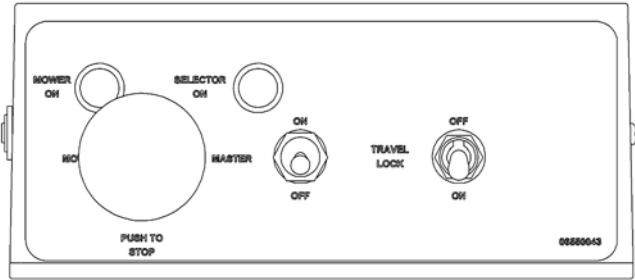



# DANGER

### SAFETY SHIELD & DEFLECTOR OPERATION



**SAFETY SHIELD**

**DEFLECTOR**

- Failure to close Safety Shield and Deflector may allow objects to be thrown outward with great force which can cause property damage, bodily injury, or death.
- 1. Keep Safety Shield and Deflector fully closed when cutting grass and weeds to reduce possibility of objects being thrown outward by the Blades if persons are in the area.
- 2. Before Cutting brush, trimming limbs, or other such operations, raise the Deflector and Safety Shield fully to allow the blades to contact the material if area is clear of passerby. Operator must stop cutting and close shield if passerby enters the thrown objects area or blade contact area.
- 3. Repair or replace Safety Shield and Deflectors as needed.
- 4. Always transport with Safety Shield and Deflector closed.

02967867

# OPERATION

# OPERATION

ŠÒXÒÜÄĀFĀT ĀĒĀÓUUT

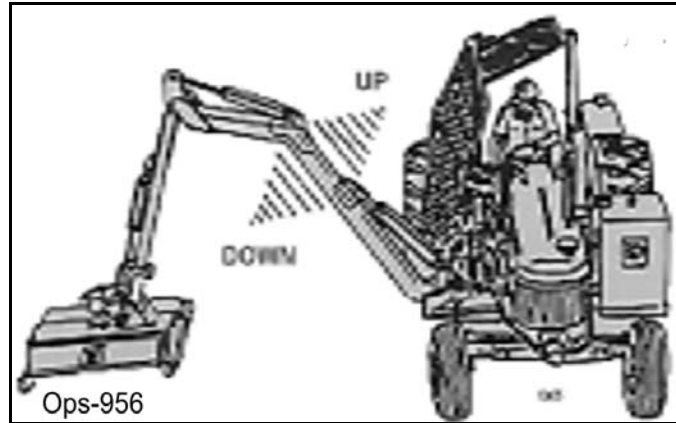

ŠÒXÒÜÄĀĀŪÒÓUĀÖĀŸĀÓUUT

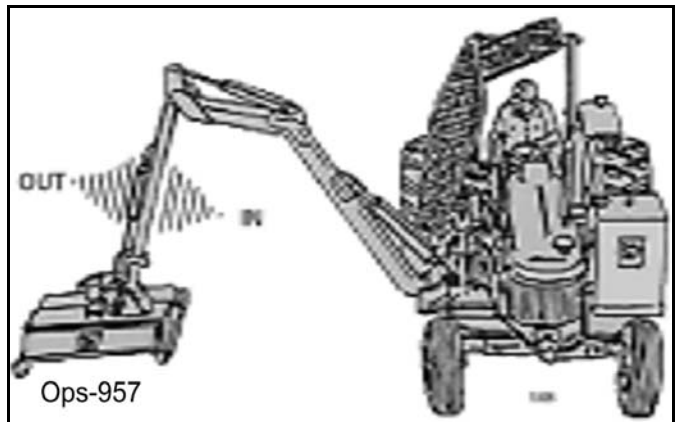

ŠÒXÒÜÄĀĤÖÖÔSĀUŠŠ

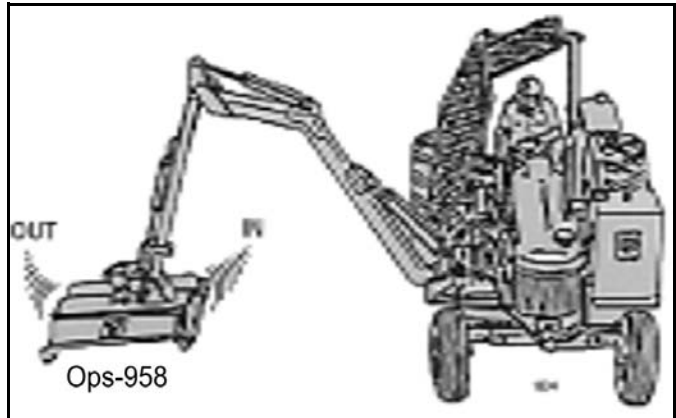

Ó[[{

U] ^! aā } Ā ^ & ā } Ā Ē Ē

# OPERATION

OPERATION

ΣΧΟΛΙΑΙ ΑΟΥΤ ΑΥ ΑΟΣ

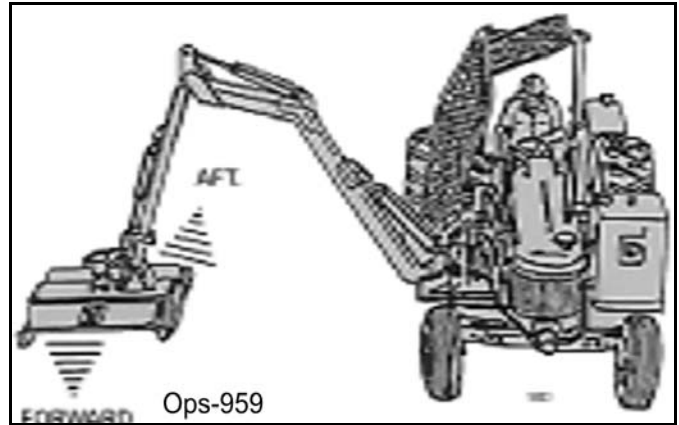

ΣΧΟΛΙΑΙ ΑΟΥΤ ΑΥ ΠΟΣ

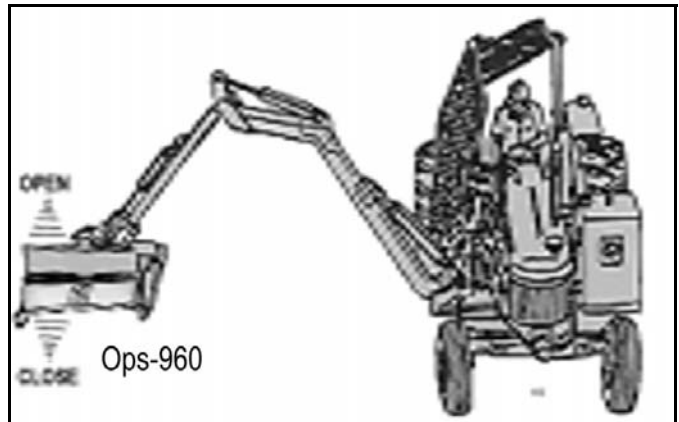

Ó[ {

U] ^! aã } Á^ & ç } Á Ë G



# OPERATION

OPERATION

## 7. Joystick Controlled Mowers

**WARNING**

DO NOT operate the mower until you have read and understood the operator's manual. Failure to do so may result in injury or death.

Always use proper mowing techniques. Do not operate the mower on uneven terrain or slopes. Do not operate the mower with the deck raised or in transport position. Do not operate the mower with the PTO engaged.

**CAUTION**

Do not touch the PTO shaft or any other moving parts of the mower while the engine is running. Do not touch the deck or any other parts of the mower while the engine is running. Do not touch the PTO shaft or any other moving parts of the mower while the engine is running.

**CAUTION**

DO NOT touch the PTO shaft or any other moving parts of the mower while the engine is running.

Do not touch the PTO shaft or any other moving parts of the mower while the engine is running. Do not touch the deck or any other parts of the mower while the engine is running. Do not touch the PTO shaft or any other moving parts of the mower while the engine is running.

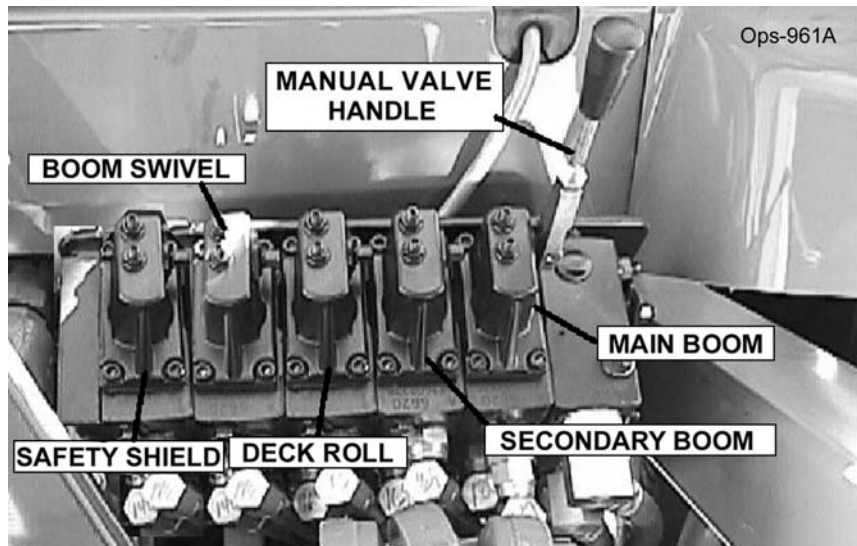

U111

U111

# OPERATION

OPERATION

## 7.1 Switch Box and Joystick Control

V@Áãæ!æ •Áà^[[, Áæ}áÁ[ }Á@Á^æÁ æ^Á @, Á@Á }&ç }•Á@æÁ^Á^!-!{ ^áÁ@[ ~\* @Á@Á •^Á Á@ ð^•æÁ&[ }d[ ||^!É

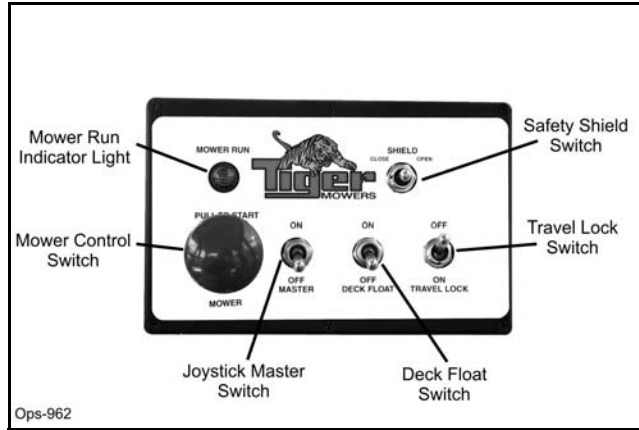

V@ÁæcÁ@|áÁ æ&ç[ ]^}•Áæ}áÁ[ •^Á@Á @|áÁ[ &æ^áÁ }Á@Á[ ] çÁ Á@&æ!Á@æÉV @} Á [ çã \* Áæ [!Á^æÁ@Á^! ] }áÉæ, æ•Á@æ^Á@Á @|áÁ Á@Á&[ •^áÁ [ •æ }ÉV @} Á [ çã \* Áæ Áá! •ç!Á Á^•Áæ[ ç^ \*! ] }á^ç^Á@Á @|áÁ æÁ^Á ]^áÁ!Áæ a!Á&æ \*ÉV^æÁæ}áÁ ||, Á@Á æ}á \*Á }Á@Á^&çÁ @, } á^[[, **Do not run the cutter into material larger than 6" diameter.**

**! DANGER**

**SAFETY SHIELD OPERATION**

- Failure to close Safety Shield may allow objects to be thrown outward with great force which can cause property damage, bodily injury, or death.

1. Keep Safety Shield fully closed when cutting grass and weeds to reduce possibility of objects being thrown outward by the Blades and to prevent contact with the Blades if persons are in the area.
2. Before cutting brush, trimming limbs, or other such operations, raise Safety Shield fully to allow the blades to contact the material if area is clear of passersby. Operator must stop cutting and close shield if passerby enters the thrown objects area or blade contact area.
3. Repair or replace Safety Shield as needed.
4. Always transport with Safety Shield closed. Ops-963

Ó[ {

U ] ^!æ } Á^&ç } ÁÉ

# OPERATION

OPERATION

## Joystick Control

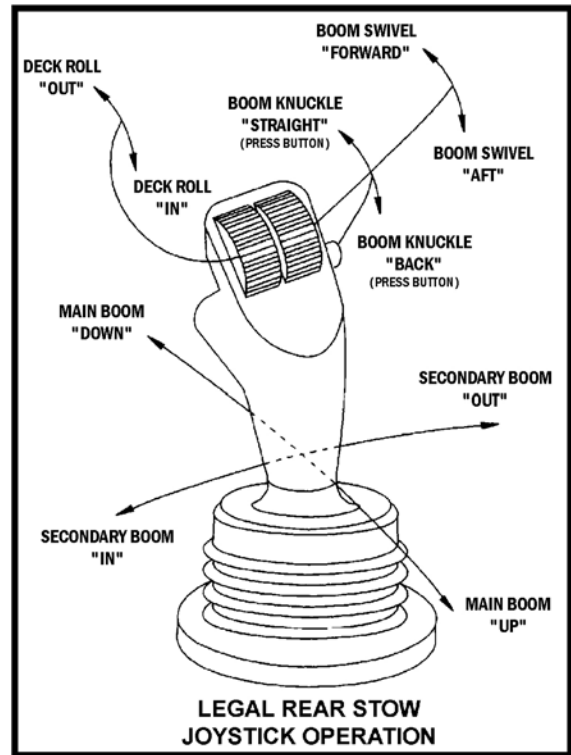
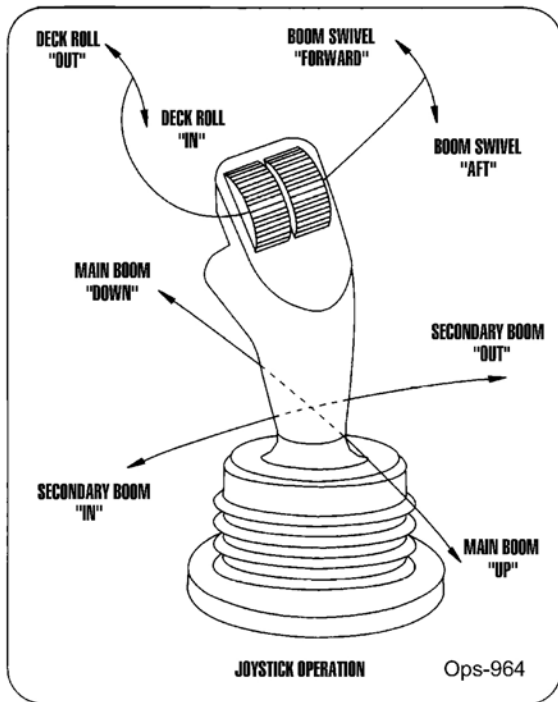

RUÿÙVÔSÁY ÖÖCÔSÁ UXÒÙÁ ÇD ÁÓUT

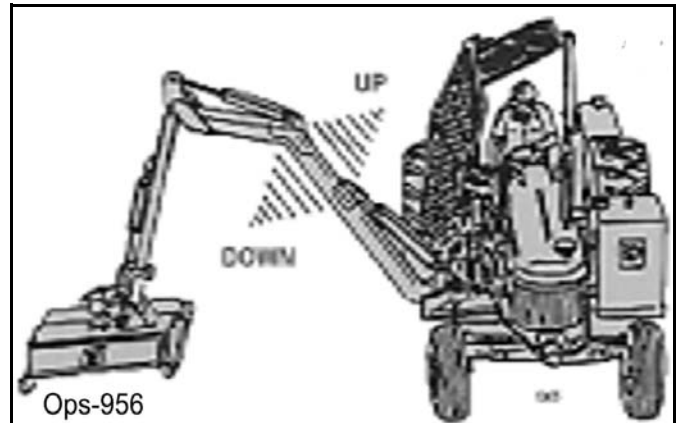

Ó[[{

U] ^! aã } Á ^ & ç } Á Ë Ç

# OPERATION

OPERATION

RU ÝÙVÛSÁŠÛVÛÛP VÁ T UXÒÙÁÙÒÓU PÛÛÛ  
ÓUUT

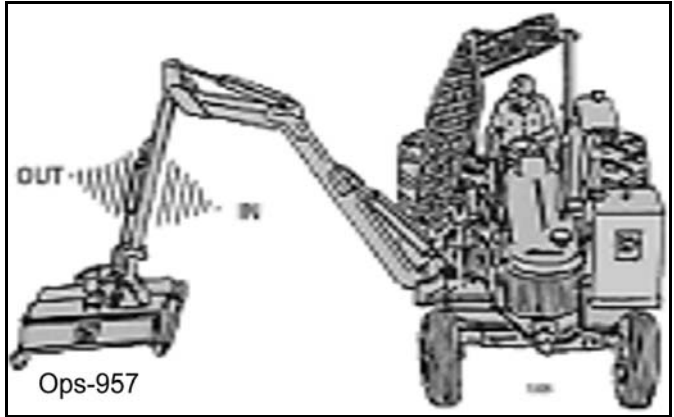

ŠÛVÁ RU ÝÙVÛSÁJU ŠŠÛÁ T UXÒÙÁÙÒÓSÁJU ŠŠ

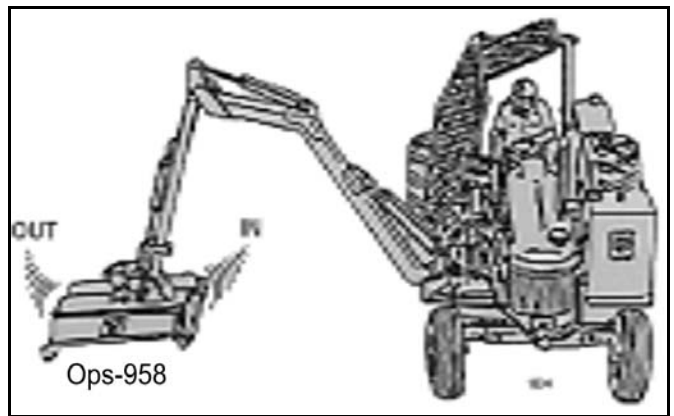

ÛÛP VÁ RU ÝÙVÛSÁJU ŠŠÛÁ T UXÒÙ Á ÓUUT  
ÙY ÑÓŠ

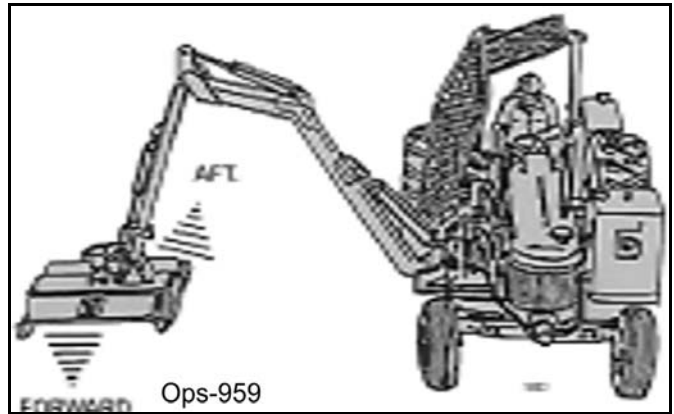

Ó [ {

U ] ^ { } Á Ú & ç } Á È Ğ

# OPERATION

ÜÖPVARUJYÜVÖSÄÜÜSSÖ ÜÄY PÖÖÁÜÜÖ ÜÜÖÖ  
ÓVVUÞÁT UXÖÜÁÓUUT ÁÞWÖSSÖÁÞÞÁÖÖÖÖÖÖ  
ÜÖÖÜÁVUY ÁÓUUT

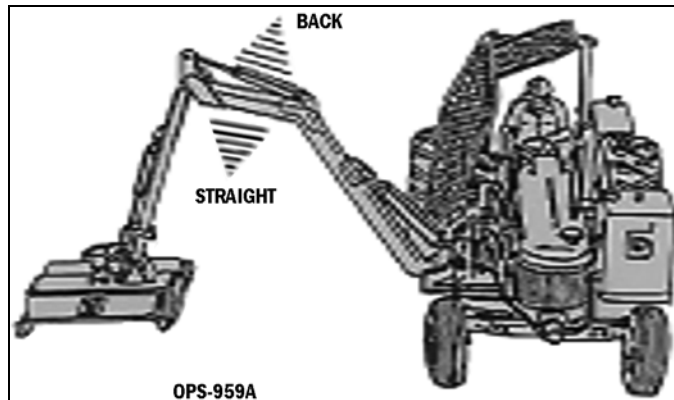

ÜPÖÖÖÁ ÜY ÖÖPÖ} Á•, ä&Ö ä[ ÖDÁ UÜÖÜÖVÖÜ  
ÜÖÖÖVYÁPÖÖÖ

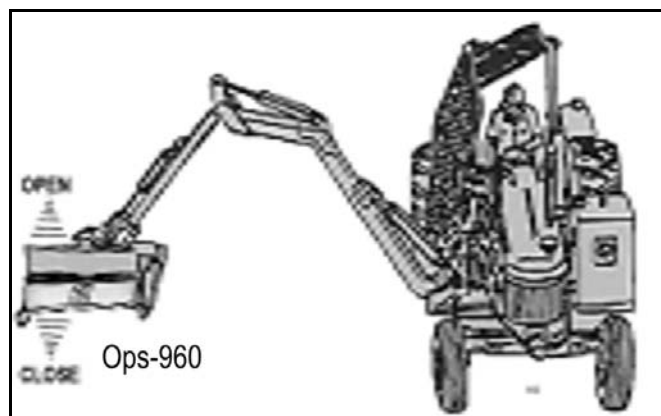

OPERATION

## 8. DRIVING THE TRACTOR AND IMPLEMENT

ÜæÁÁæd [Áæ] [!Á~ ¢Á@Á] Áæ!Á Á [•••ÁÁ@!~ \* @Á] [ |á^Á -Á@Á [á^Áá \* Á] Áæá  
æ áÁ ^æ ç} •Á Áæ Á @Ááá \* Á á@Á Áææ@áÁ ] |{ ^} ÖÖ) • ^Á@Áæd Á@Á@Áææ æÁ Á  
æ á^Á@Á ^á @Á -Á@Á [[ Áæ á@Áæd Á] Áæá \* Á] d | •Á^Á^Á ÁæÁæ} [!ÖÁ Á) • ^Áæ  
, @Áááá \* Á@Áæd Á á@Á [[ ÖÁçá, Á@Á ||, á \* É

ÜæáÁæÁæc Á • d & ç} • ÖÖÁæ Á @Á [ Á æ] Á ~ Á Á ææ |æá áÁ ~ |ç |Áææá • ÖÜ [ ^Ááæ  
æ^Áææ@áÁ [ ^Á Á æÁ -Á@ Á [ Á @ ^Á@ ^Áá Á [ •æ |Áææ ááÁ^æá Áæ áÁ æ^Á ~ ^Á [ ~  
~] á! • ç} á@Áæc Á ( ••æ ^Á^Á ^Á [ Á] ÁæÁ@Á ] |{ ^} ÖÖÁ^Á ÁæÁáæ Á^æ Áæ áÁ^æá^É  
Ü^ |æÁ • Ö! Áæ æ^Ááæ ÖÁ^Á Áæc Á & ç} Á Á [ ^Á ç] É

S^Á ÁæÁ Á! • [ ] ÖÁ ^ |Ááá Á [ , ^Áá & Ááæá Áæ Á@ , Á á & Á á@ ^Áá^ | & ç Á | Áæ} • æ^áá  
áæ ç & ÖÖÖÖÖÖÖÖÖÖ OPS-B- 0005

Ö [ {

Ü] Áæ } Á & ç } Á Ö

# OPERATION

**⚠ DANGER**

Before starting the engine, read the operator's manual. It contains important information about the safe use of the tractor. Failure to read the manual may result in serious injury or death.

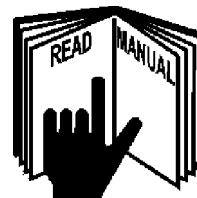

**⚠ WARNING**

Do not drink alcohol or use drugs before operating the tractor. This can impair your judgment and ability to operate the tractor safely. It is illegal to operate a vehicle while impaired.

**⚠ DANGER**

Always use proper tie-down technique when securing loads. Use the correct number of tie-downs and distribute the load evenly. Always check the load and secure it before driving. Never exceed the rated capacity of the tie-downs or the vehicle's weight capacity.

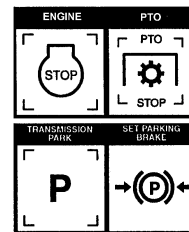

OPERATION



# OPERATION

OPERATION

## 8.2 Brake and Differential Lock Setting

T æ ^ Á ~ | ^ Á @ Á i æ d | Á i æ æ ^ Á æ ^ Á æ Á [ [ á Á ] ^ i æ æ \* & [ } á æ æ } É V i æ æ d | Á à i æ æ ^ Á æ æ Á à ^ Á ^ Á æ d Á ] ^ i æ æ æ á æ ^ ) á ^ ) d ^ Á æ [ , æ \* Á æ \* ^ Á ^ Á æ Á @ ^ Á à i æ æ æ \* æ æ æ } Á | Á [ & ^ á Á æ \* ^ Á @ Á d Á | [ ç æ ^ Á æ ~ | æ æ ^ ~ ^ Á æ Á @ ^ Á à i æ æ æ \* É Á Á U Ü Á T U Ü V Á Ö U Q X Q Ö Á C E Ö U U Ö U C E Ö Ö Á U P Ö Ö Q W P Ü É V P Ö Á U Ö C S Ö Á U Ö Ö C S Ü Ü P U W S Ö Á Ö Ö Á U Ö S Ö Ö Á U Ö Ö V P Ö Ö Á U Á U Ü U X Ö Ö V P Ö Á T U Ü V Á Ö Ö Ö Ö V Q Ö Á U Ö C S Ö Ö Á C E Ö V W P É



Ö. æ • Á æ ^ ) \* æ ^ Á @ Á i æ d | Á à æ ^ Á ^ ) æ æ Á [ & Á @ } c } } æ \* É Y @ } Á } \* æ ^ á Á @ ^ Á à æ ^ Á ^ ) æ æ Á [ & Á æ ] ] ^ ç ^ ) Ö Á | Á æ æ Á @ Á d æ d | Á + [ { Á c } } æ \* É Ö ^ i æ \* } [ { æ Á & ^ ç æ \* Á æ } á æ æ } • É Á [ & æ \* Á @ Á à æ ^ Á ^ ) æ æ ] [ [ ç æ ^ Á [ Á ^ ) ^ á Á æ á Á @ ^ ~ | á Á [ Ö Á Á ^ Á æ É Á

OPS-U- 0013

**WARNING** Ö Á æ æ ^ Á ^ Á @ Á ] ^ i æ æ \* Á [ } á æ æ } • É Ö [ Á [ Ö Á ] ^ i æ æ Á @ Á i æ d | Á à Ö Á ^ á Á | Á æ | c Á i æ æ ^ É Y @ } Á ] ^ i æ æ \* Á [ , } Á Á @ Á | Á } Á ^ Ö Á | Á æ Á | Á Á [ æ æ É Á @ Á i æ æ æ \* Á à ç æ & Á æ & ^ æ ^ Á ~ ^ Á ç d ^ { ^ Á æ æ Á æ á Á á ^ & Á [ ^ Á ] ^ á Á Á Á @ Á ^ Á [ } á æ æ } • É Y @ } Á ] ^ i æ æ \* Á Á æ æ æ æ æ æ ^ Á ^ Á @ Á i æ d | Ö Á æ @ } Á æ } æ \* Á æ @ Á æ á Á á ^ & Á [ ^ Á ] ^ á Á Ö Á æ æ æ ^ Á Á i æ æ Á æ Á [ ^ Á [ ^ Á æ á , æ æ Ö Á ^ Á | Á @ Á c Á ^ É Á (Ops-0004-MISC)

**DANGER** Ö Ö Ö U Ö Á æ æ \* Á @ Á i æ d | Á ^ á Á æ æ æ , æ • Á ^ Á @ Á æ æ æ \* Á i æ æ Á æ æ á æ ! Á ^ c @ Á i æ d | Á d æ { æ • æ } Á æ Á æ æ æ \* Á ^ á Á æ æ á ^ ) \* æ ^ Á @ Á U V U É Á d ] Á @ Á ^ ) \* æ ^ Á É Á [ ç ^ Á @ Á ^ É Á æ á Á æ æ Á Á æ Á [ ç æ \* Á æ Ö Á Á d ] É Á U æ Á @ d æ d | Á @ Ö Á ç ^ Á i æ d Á æ [ , Á æ \* Á Á ] Á æ æ \* Á ^ á Á Á ^ ç ^ ) Ö Á @ Á i æ d | + [ { Á [ ] æ \* É Á ç ^ Á i æ á [ ^ ] Ö Á i æ d | Á @ Á i æ Á [ ç æ \* Á Á @ Á ] \* æ ^ á Á ^ } } æ \* É Á U ^ i æ æ Á @ Á i æ d | Á [ } d [ | Á [ { Á @ Á i æ d | Á ^ á Á } | É Á Ö Á d

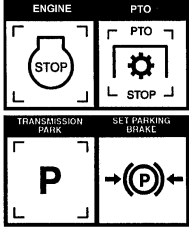

Ö [ { U ] ^ i æ æ } Á ^ á Á } Á É É



# OPERATION

## 8.3 Driving the Tractor and Boom

Use the following procedures to operate the tractor and boom:

1. Start the tractor and set the parking brake.
2. Lower the boom to the ground.
3. Move the tractor forward and backward to position the boom.
4. Lift the boom to the desired height.
5. Operate the boom controls to move the bucket.

Use the following procedures to operate the tractor and boom:

1. Start the tractor and set the parking brake.
2. Lower the boom to the ground.
3. Move the tractor forward and backward to position the boom.
4. Lift the boom to the desired height.
5. Operate the boom controls to move the bucket.



Use the following procedures to operate the tractor and boom:

1. Start the tractor and set the parking brake.
2. Lower the boom to the ground.
3. Move the tractor forward and backward to position the boom.
4. Lift the boom to the desired height.
5. Operate the boom controls to move the bucket.



OPERATION

OPS-B-0006

OPS-B-0006

# OPERATION

## WARNING

புறவிலிருந்து பாதுகாப்புக் கொடுக்கப்பட்ட இடங்களில் மட்டுமே இயங்கக்கூடிய இடங்களில் இயங்காதபடி உறுதிப்படுத்தவும். இல்லாவிட்டால், இயங்கும்போது எந்தவித பாதுகாப்புக் கொள்கையும் இல்லாமல் இயங்குவதால், இயங்கும்போது உயிருக்கு அபாயம் ஏற்படும்.



## DANGER

பொருள் கையாள்வது போது, இயந்திரம் இயங்கும்போது எந்தவித பாதுகாப்புக் கொள்கையும் இல்லாமல் இயங்குவதால், இயங்கும்போது உயிருக்கு அபாயம் ஏற்படும். இயந்திரம் இயங்கும்போது, இயங்கும்போது உயிருக்கு அபாயம் ஏற்படும்.

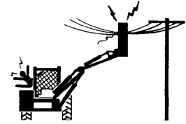

## OPERATION

### 9. OPERATING THE BOOM UNIT AND ATTACHED HEAD

THE OPERATOR MUST COMPLETELY UNDERSTAND HOW TO OPERATE THE TRACTOR AND MOWER AND ALL CONTROLS BEFORE ATTEMPTING TO MOW. இயந்திரம் இயங்கும்போது, இயந்திரம் இயங்கும்போது உயிருக்கு அபாயம் ஏற்படும். இயந்திரம் இயங்கும்போது, இயந்திரம் இயங்கும்போது உயிருக்கு அபாயம் ஏற்படும்.

இயந்திரம் இயங்கும்போது, இயந்திரம் இயங்கும்போது உயிருக்கு அபாயம் ஏற்படும். இயந்திரம் இயங்கும்போது, இயந்திரம் இயங்கும்போது உயிருக்கு அபாயம் ஏற்படும்.

இயந்திரம் இயங்கும்போது, இயந்திரம் இயங்கும்போது உயிருக்கு அபாயம் ஏற்படும். இயந்திரம் இயங்கும்போது, இயந்திரம் இயங்கும்போது உயிருக்கு அபாயம் ஏற்படும்.

இயந்திரம் இயங்கும்போது, இயந்திரம் இயங்கும்போது உயிருக்கு அபாயம் ஏற்படும். இயந்திரம் இயங்கும்போது, இயந்திரம் இயங்கும்போது உயிருக்கு அபாயம் ஏற்படும்.

## WARNING

இயந்திரம் இயங்கும்போது, இயந்திரம் இயங்கும்போது உயிருக்கு அபாயம் ஏற்படும். இயந்திரம் இயங்கும்போது, இயந்திரம் இயங்கும்போது உயிருக்கு அபாயம் ஏற்படும்.

## WARNING

இயந்திரம் இயங்கும்போது, இயந்திரம் இயங்கும்போது உயிருக்கு அபாயம் ஏற்படும். இயந்திரம் இயங்கும்போது, இயந்திரம் இயங்கும்போது உயிருக்கு அபாயம் ஏற்படும்.









OPERATION

OPERATION

Y @ ) / & ~ ʘā \* Á / ^ ^ . Áā ā Á / ~ . ʘāē ] : | ʘāē ʘāē ʘē  
ŧ Á / Á & ʘāē ʘāē ʘāē Á / ^ ^ ) ā ʘē | ʘāē Á / Á ʘāē ʘāē É  
V @ Á & ~ ʘāē \* Á / ā \* ^ Á / Á ʘāē Á / ʘāē ʘāē Á / ^ ʘāē \* | ā Á / ^ Á ʘāē  
[ ] | ^ Á / ^ ^ ) ʘāē Á / & ] ʘāē ʘāē ʘāē É V @ Á / ʘāē ʘāē  
ā ʘāē Á / ʘāē | ā Á / ʘāē ) ʘāē ʘāē ʘāē É V @ Á / Á [ , ^  
ʘāē ʘāē ʘāē ā Á / ā ʘāē Á / ^ ʘāē \* ʘāē | ā Á / ā Á { [ ŧ ^ ā  
] ^ ) ā ʘē | ʘāē Á / ŧ Á / Á ʘāē Á / ʘāē Á / Á / , ^ ā \*  
ʘāē Á [ , ^ Á / ʘāē Á / Á / ] Á / Á ʘāē É V @ Á / ʘāē ʘāē  
ā ʘāē Á / ā \* Á / Á / ^ ^ \* ^ ā Á / Á / ~ ) ā ā Á / [ { Á ^ ʘāē ʘāē  
{ [ , ^ Á / ʘāē Á / ā ā ā \* Á / ^ ā Á ā & ] ^ ā & ŧ Á / Á ʘāē  
ʘāē \* ʘāē Á / ʘāē ) ^ É V @ Á / ʘāē ʘāē Á / Á / ʘāē ) ā ā Á /  
& ~ ʘāē ʘāē Á / Á / Á / ^ ā ʘāē { Á / ^ Á / ʘāē Á / É  
Ō Á / ʘāē [ , ^ Á / ʘāē Á / Á / Á / ʘāē Á / ʘāē Á / & ] ʘāē ʘāē  
ʘāē ʘāē [ ~ ] ā Á / & . Á / Á / | ʘāē Á / ā b & c . É Ō [ ] ʘāē ʘāē  
ʘāē ʘāē [ ~ ] ā Á / ʘāē Á / ^ | ʘāē Á / & . Á / ʘāē ā Á / | ʘāē Á / ā b & c  
ā ā ā \* Á / ʘāē [ , ] Á / ~ ʘāē [ { Á / } ā Á / ʘāē Á / [ , ^ Á / ʘāē  
, ʘāē ʘāē Á / ʘāē \* ^ Á / ^ ā \* ^ ā b i a . Á / Á / ʘāē Á / ^ ʘāē  
ā ā Á / ^ ʘāē ā Á / É V @ Á / ^ Á / Á / ^ ʘāē ) Á / ʘāē Á / ʘāē  
ŧ Á / Á / ʘāē Á / ^ ^ ) Á / ʘāē Á / ʘāē É Á / \ ^ ^ ) Á / ʘāē Á / Á / |  
ā ā Á / \ ^ ^ ) Á / ʘāē Á / ʘāē Á / ʘāē Á / ^ ^ ) ā | ā / | ʘāē Á / ʘāē  
ā ā Á / ʘāē \* ^ | ^ ^ ) Á / ʘāē Á / ^ ʘāē ) Á / ʘāē ā Á / ^ ʘāē ā Á / É

(OPS-R-220)

9.6 50" Boom Flail

V @ Á / É Á / [ [ { Á / ʘāē Á / [ , ^ Á / ʘāē Á / ā ) ^ ā Á / Á / & ~ ʘāē \*  
ā / ~ . ʘāē ā Á / | ʘāē ^ Á / Á / Á / Á / & ʘāē Á / ā ā ā ʘāē ^ ʘāē Á / |  
{ ~ | ʘāē | Á / ā / ʘāē & ʘāē . Á / ʘāē ʘāē Á / ʘāē ʘāē Á / ʘāē Á / & ʘāē  
ā ā ʘāē ^ ~ ʘāē ʘāē ) ʘāē Á / ] ^ Á / Á / ʘāē & ʘāē ā / ʘāē & ʘāē Ō ~ ʘāē \*  
{ ~ | ʘāē | Á / ā ā ā ʘāē ^ Á / ʘāē ^ Á / ʘāē Á / ʘāē | | ʘāē Á / ʘāē  
{ [ , ^ Á / ʘāē \* ʘāē Á / Á / [ , Á / [ , ] Á / Á / ʘāē Á / [ ] | ʘāē É  
^ \* ʘāē ā / ~ ʘāē Á / ʘāē Á / ā ā Á / Á / ʘāē ʘāē Á / ā ā \* Á / & É V @  
& ~ ʘāē Á / ʘāē ) ^ ā Á / ~ . ʘāē Á / ʘāē ʘāē ^ ā É V @ Á / ^ . ^ Á /  
ʘāē Á / ʘāē & ~ ʘāē Á / ʘāē Á / } ā \* ʘāē ʘāē ~ { Á / ^ ā É  
| ~ ) Á / ʘāē Á / ʘāē | Á / ʘāē ~ | | Á / ʘāē | ʘāē ā / ā \* Á / { [ , ā \*  
[ ] ^ ʘāē ) . É V @ Á / & ~ ʘāē Á / ʘāē [ , . Á / Á / Á / ā ʘāē  
ʘāē ʘāē ) ʘāē . Á / Á / | ā ā \* Á / ʘāē É [ ŧ Á / ʘāē Á / [ , ^ Á / ʘāē  
ā ā ʘāē [ { Á / ʘāē | ʘāē ^ Á / ʘāē ā Á / [ , Á / & ~ ʘāē Á / ʘāē  
! \* ʘāē Á / | | Á / ^ ā É

- WARNING** U | ^ ʘāē \* Á / ʘāē [ , ^ Á / ʘāē ʘāē ) ^ Á / ʘāē Á / [ , . Á / ʘāē ) ʘāē Á / & ] ʘāē ʘāē Á / | ā / ʘāē \ Á / | ʘāē [ , ā \*  
\ } ʘāē Á / \* . Á / & ] ʘāē ʘāē | ʘāē ^ Á / ā / ʘāē \* ^ Á / ^ ( ʘāē ) ʘāē ʘāē Á / ʘāē & ~ ʘāē Á / ʘāē ^ Á / ʘāē { É V @ Á / ʘāē ā  
\ } ʘāē ʘāē ʘāē ) ^ ʘāē ʘāē É
- WARNING** V @ Á / É Á / [ [ { Á / ʘāē Á / & ~ ʘāē Á / ʘāē Á / ^ ā ) ^ ā Á / Á / ʘāē ) ā ā ā Á / ʘāē ) Á / ʘāē ^ Á / ʘāē ) Á / ʘāē Á / ʘāē É  
, ʘāē Á / ^ ā \* Á / , ʘāē Á / ʘāē | **Never operate the cutter shaft in reverse rotation.** U | ^ ʘāē \*  
ʘāē Á / [ , ^ Á / Á / ʘāē Á / ʘāē ) Á / ʘāē ʘāē \* ^ Á / ā b & c Á / Á / Á / [ , ] Á / ʘāē Á / [ , ^ Á / ʘāē É
- WARNING** V @ Á / É Á / [ [ { Á / ʘāē Á / ~ ā ) ^ ā ā ā ʘāē , ā \* ā \* Á / ~ . ʘāē ) ʘāē Á / & ~ ʘāē ) ^ ā Á / | Á / ~ . ʘāē ʘāē \* Á / ] ^ É  
Ō ~ ʘāē \* Á / ʘāē Á / ʘāē [ ʘāē & ] { ^ } ā ā É

**CORRECT** **INCORRECT**

The cutter deck should be level with the ground to reduce the work required by the cutter and tractor to minimize equipment wear and damage.

Ops-1480



# OPERATION



WARNING: Read and understand the operator's manual before operating this machine. Failure to do so could result in injury or death. Always use proper operating techniques and wear your seat belt.

## 9.7 63" Boom Flail

The boom flail is a safety device that allows the operator to disengage the flail from the PTO shaft. This is done by pulling a lever on the side of the boom flail. The lever is located on the left side of the boom flail, near the front of the machine. The lever is marked with a PTO symbol. When the lever is pulled, the PTO shaft is disconnected from the flail, and the flail will not rotate. This allows the operator to transport the machine safely without the flail rotating. To re-engage the flail, the lever must be pushed back into its original position.

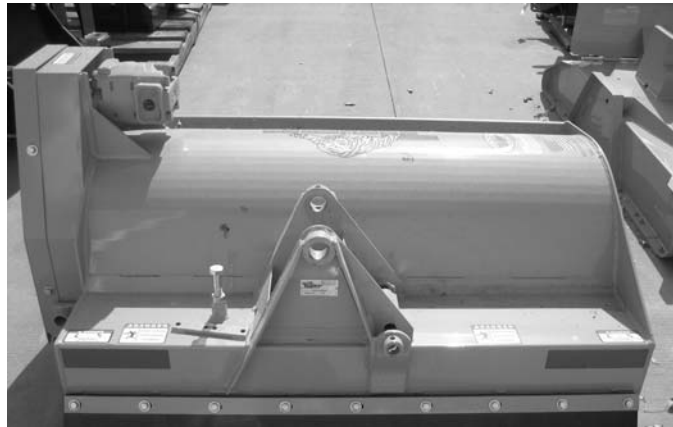

DANGER: The boom flail is a safety device that allows the operator to disengage the flail from the PTO shaft. This is done by pulling a lever on the side of the boom flail. The lever is located on the left side of the boom flail, near the front of the machine. The lever is marked with a PTO symbol. When the lever is pulled, the PTO shaft is disconnected from the flail, and the flail will not rotate. This allows the operator to transport the machine safely without the flail rotating. To re-engage the flail, the lever must be pushed back into its original position. Failure to disengage the flail could result in injury or death.



DANGER: The boom flail is a safety device that allows the operator to disengage the flail from the PTO shaft. This is done by pulling a lever on the side of the boom flail. The lever is located on the left side of the boom flail, near the front of the machine. The lever is marked with a PTO symbol. When the lever is pulled, the PTO shaft is disconnected from the flail, and the flail will not rotate. This allows the operator to transport the machine safely without the flail rotating. To re-engage the flail, the lever must be pushed back into its original position. Failure to disengage the flail could result in injury or death.

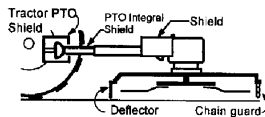

WARNING: The boom flail is a safety device that allows the operator to disengage the flail from the PTO shaft. This is done by pulling a lever on the side of the boom flail. The lever is located on the left side of the boom flail, near the front of the machine. The lever is marked with a PTO symbol. When the lever is pulled, the PTO shaft is disconnected from the flail, and the flail will not rotate. This allows the operator to transport the machine safely without the flail rotating. To re-engage the flail, the lever must be pushed back into its original position. Failure to disengage the flail could result in injury or death.



# OPERATION

OPERATION

## 9.8 Shutting Down the Attached Head- For Standard Equipment

1. Turn the ignition key to the OFF position.  
 2. Lower the PTO lever to the OFF position.  
 3. Lower the lift arms to the ground.  
 4. Turn the lift arms to the DOWN position.  
 5. Turn the lift arms to the UP position.  
 6. Turn the lift arms to the DOWN position.  
 7. Turn the lift arms to the UP position.  
 8. Turn the lift arms to the DOWN position.  
 9. Turn the lift arms to the UP position.  
 10. Turn the lift arms to the DOWN position.

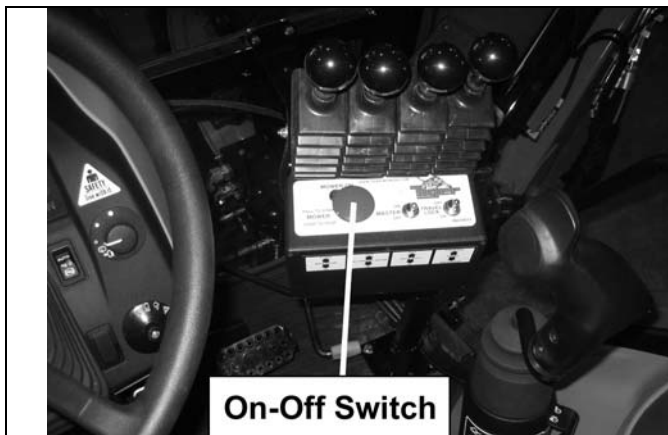

1. Turn the lift arms to the DOWN position.  
 2. Turn the lift arms to the UP position.  
 3. Turn the lift arms to the DOWN position.  
 4. Turn the lift arms to the UP position.  
 5. Turn the lift arms to the DOWN position.  
 6. Turn the lift arms to the UP position.  
 7. Turn the lift arms to the DOWN position.  
 8. Turn the lift arms to the UP position.  
 9. Turn the lift arms to the DOWN position.  
 10. Turn the lift arms to the UP position.



**DANGER**

1. Turn the lift arms to the DOWN position.  
 2. Turn the lift arms to the UP position.  
 3. Turn the lift arms to the DOWN position.  
 4. Turn the lift arms to the UP position.  
 5. Turn the lift arms to the DOWN position.  
 6. Turn the lift arms to the UP position.  
 7. Turn the lift arms to the DOWN position.  
 8. Turn the lift arms to the UP position.  
 9. Turn the lift arms to the DOWN position.  
 10. Turn the lift arms to the UP position.

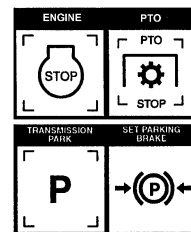

011

U] ! & } Á & } Á Æ U









# OPERATION

## 11.3 Hauling the Tractor and Implement

Before towing, ensure the tractor is in neutral and the parking brake is applied. Use proper hitching technique to avoid damage to the tractor and implement. Refer to the operator's manual for detailed instructions.



Use proper hitching technique to avoid damage to the tractor and implement. Refer to the operator's manual for detailed instructions.

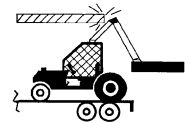

When towing, ensure the tractor is in neutral and the parking brake is applied. Use proper hitching technique to avoid damage to the tractor and implement. Refer to the operator's manual for detailed instructions.



OPERATION

U] ^{

U] ^{

# OPERATION

OPERATION

0E!æ \*^Ác@Á&@æ•Á•[Ác@æÁ, @}Áæ @^}^áÆÁc@  
 &@æ•Á æ^Á~||æ \*Á[ ], æáÁ æ áÁ æ ææ•c  
 c@{•^|ç^•ÆÁæ^~||^Áæ @^}Ác@Á^&|æ \*Á&@æ•Á!  
 [c@!Áææç}^!•Á•æ \*Áæ[[{^!•Á!Áææ á^!•Áç Áæ]]|^  
 {ææ~{Áç}•æ}ÆÁ^Á^Áçd^ {^Á&æ^Á, @}  
 æææ@ \*Áæ áÁ^ {çæ \*Ác@Á^&|æ \*Áæçæ•Áæ Ác@  
 ^çd^ {^Áç}•æ}Áæ ç|ç^áÁ, @}Á!^ææ^áÁæ Ác@  
 ]|ç}æææ ç ç^Á^!æ~•Áç b!^É



Op - 48

Y @^Áæ ç|æ \*Ác@Áçæç!Áæ áÁæ ]|^ (^) ç{ æ^  
 [æææ ç}æ^•ç]•Áç Á&@& Ác@æÁc@Áçæç!Áæ á  
 æ ]|^ (^) ç^æ^Á[ç^áÁ!Á çæ^áÁæ áÁc@æÁc@  
 •^&|æ \*Á&@æ•Áçæ^Á çæ ææ^áÁ}•æ}ÆÁ^Á^!æ \*  
 çæ•][!çææáÁ!ææ ç^Æ çæ]Áç!}æ^Á!Á, ^!çæ \*  
 çæç}Á æ^Á!ç|{^áÆ ç]ææ@Á^ççæ^Á çææ]  
 ç ç•] ^&Ác@Á^&|æ ç^Á^Á çæOPS-U- 0026

**CAUTION**

Çææ^Á!Á[ç^!^&ç^Áç^!ÆÁc@Á[[{Á ç!Á}áÁÁ, æ^•Áç, ^!Áæ^Ææ^Áç@!  
 ]^!•[}]^!Áææ^Á ç]ç|ÁÁ, æ^æ \*Á [ç]Á @}Á&|æ á^!Á ç^Á^ {ç^áÆ æ^Á!^Ác@  
 ]^!•[}]^!Áç^Á [ç ç]•æ}Á ç^Áç^!Á^•@áÁ^Á, æ^æ \*Á [ {Æ

Ü^çæç, ç^!Á ç|æ á^!Áæ áÁ&|Á çæ Áæ^ÆÁ çæ^Á çæ[[{Á!, æáÁ ç^Áç}ç!Á^ÁæáÁÆ, ^!Á&Á ç  
 c@Á çæ^Á^áÆæ áÁ @ç^Ác@Áç ç|Æ@Áçæç!Áæ áÁç [ , ^!Ác@æ^Á ç^!áÁ [ , Á^Á&æ^áÁ [ , }Á^&|Á^  
 ç Ác@Áçæ^Á^áÆ

**CAUTION**

Çæ^Á çç^Á^Á^Á ^!ææ \*Á^&ç}Æ!Áæ^Áç@!Á^&ç}Á ç^Á çæ^Á[ç { ]|^ç!  
 ~}á^!ç [áÆ] çæç^!^!Á^!Áæ^Á!Á!Ác@Áæá!•Á}Ác@Áç ç^!Á^Á çæ^Á!  
 ç•æ çæ &^Á

Ó[ { U|^ææ}Á^&ç}ÁÆ!

# OPERATION

OPERATION

Ó[ {

U] ^! aã } Á^ &ã } ÁÈ î



# MAINTENANCE SECTION

T aq c} a} &^Á^&c} Á E



# MAINTENANCE

**WARNING**

Do not use the engine for any purpose other than that intended. The engine is designed for use only as a power source for the tractor. Do not use the engine for any other purpose.

**WARNING**

Do not use the engine for any purpose other than that intended. The engine is designed for use only as a power source for the tractor. Do not use the engine for any other purpose.

**DANGER**

Do not use the engine for any purpose other than that intended. The engine is designed for use only as a power source for the tractor. Do not use the engine for any other purpose.

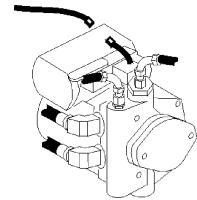

MAINTENANCE

## MAINTENANCE OF CRANKSHAFT ADAPTER ASSEMBLY (RIGID ENGINE MOUNT TRACTORS ONLY)

For information on the maintenance of the crankshaft adapter assembly, refer to the maintenance manual for the tractor. The crankshaft adapter assembly is used to connect the engine to the tractor's drivetrain. It consists of several components, including an adapter, flatwasher, rubber grommet, neoprene washer, and steel grommet. The assembly should be inspected regularly for wear and damage, and replaced as needed. The maintenance procedure is described in the following steps.

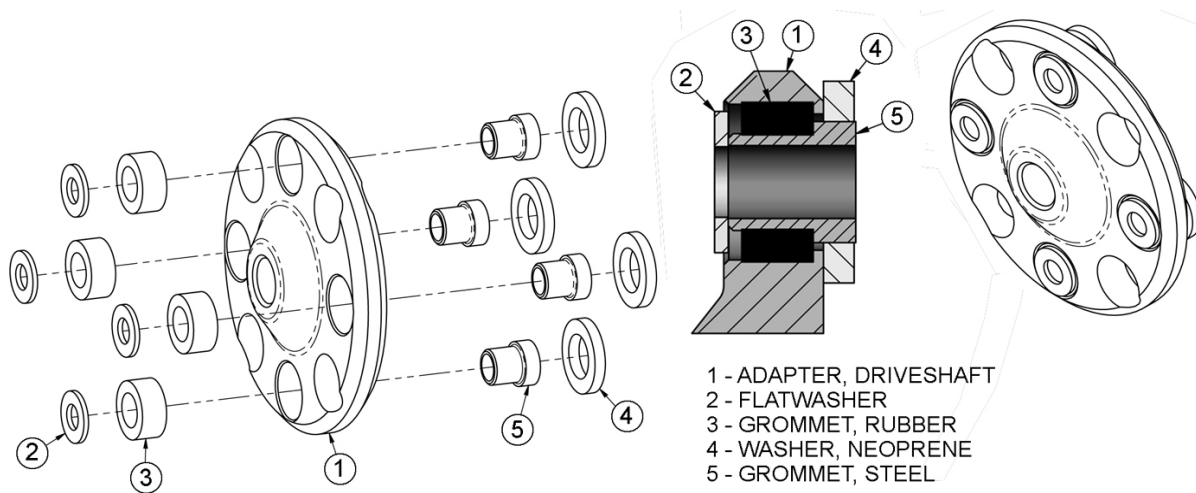

©

T

# MAINTENANCE

MAINTENANCE

## Regular Maintenance

V@Á q:çap Á@Á @Á^\* |æÁ^çapá \*Á @ |áÁ^Á | ^Á^Áæ^áÁ } Á@ | Á-Á | ^Áæ } ÉV^Á@Áæç | Á@ | { ^ÁÁÁ Á^Á | á^Á @ } Á^\* |æÁ^çapá \*Á^~ á^áÉ

Ü^Á | Á@ Á@Á^c æ^áÁT æ ç } æ & Á^Á&ç } Á | Á~ c@ | Á@ .d~ &ç } •Á } Á^!æá \*ÉÁ[ ] ^Áæ áÁ^Á@ ÁÖæ T æ ç } æ & Á @ ^Á | æ áÁ@Á } áÁ Á@Á&ç } É

## Daily or Every 8 Hours

QÒT Á	ÜÖÜXÒ	ÔUTT ÒPVÜ
Ö:á^Á@Á^   ^ÉMÉ ç c BÁÜc àÁ@æ	Ö:Áæ^	Ö:Áæ^Áæ ç .d~ &c^á/ç á^æá^áÁ æ ç } æ & Á^Á&ç }
Ü { ] ÁÖ:á^Á@Á^ [ ~ ]   ^	Ô@ & Á áÁ~ á^	Q~   ^Á   á^ .@Á } áÁ   æ
Ö:æ   .@Á^æ ç   Á	Ô@ & Á^ á^Á   [ { ^	Ü^   æ^Á   [ { ^ ÁÁ áæ æ^áÁ   Á á .á^*
Üá [ áÁ [ á	Š~ á:ææ	Q^ & Á   ^Á } ç/ç æ ] ^æ .Á } á
P^ á:æ   Á^çá * Á	Ô@ & Á   Á^æ .	Vá @ } Á @ } Á^ á^á^ÉÁ [ Á   Á^Á@á á ç & @ & Á   Á^æ .É^Á^ æ ç   ^Áæ ç } .
S) á^Á Á	Ô@ & Á	Q~   ^Á   Á á .á^ *Á   Áæ æ^áÁ } á^ .É & @ ^Á^ Á^ á^áÉ
Ü á á^Á [ ~ ç *Á     ] á á^Á Á^ & D	Ô@ &	V   ~ ^Á   Á   Á^á .É^ á:ææ á V   ~ ^Á   Á   Á^á .É^
S) á^Á [ ~ ç *Á     Q) á^Á Á^ \ Á   Á   æ^Áæ D	Ô@ &	Ü   ^É~ á:ææ Á@^æ .Á á@æ ç^ á^ á ç   ~ ^Á   Á €Á^á .É
Öá \ É   æ^Áæ Á [ ~ ç *Á     Qá \ É   æ^Áæ Á   Á ] á   ^D	Ô@ &	V   ~ ^Á   Á   Á^á .É^ á:ææ á V   ~ ^Á   Á   Á^á .É^
Ó	Ô@ & Éá^ .c	Ô@ & Á   \ ^ } Éá @ } Á^~ á^ á
T æ Á   æ ^Á áÁ Ö^ &	Ô@ & Á	Ü^ ç   ~ ^Á     Á   Á   ~ ^ ] ^Áææ } .Á Á@Á&ç }
P^ á:æ   Á^ çá^	Ô@ &	Éá^Á^~ á^ áÁ   Á   Á^ & [ { ^ } áææ } .
Ü^ á   Á@Á^ Á^ çá }   Á^ Á^D Ó^ á   Á^ á^ Á^ áÁ@Á^ [ ~ ]   ^	Š~ á:ææ	Ö:Áæ^Áæ ç .d~ &c^á/ç á^æá^áÁ æ ç } æ & Á^Á&ç }
Ö~ ç   Á@Á^ áÁ	Š~ á:ææ	Ö:Áæ^Áæ ç .d~ &c^á/ç
Ó [ {	T æ ç } æ & Á^Á&ç } Á É	

# MAINTENANCE

MAINTENANCE

Ö: [ ~ } áÄÜ [ ||^!

á^æá^áÄ æ } æ &^Á^&ç } }

## WEEKLY OR EVERY 40 HOURS

Ö: ÖT /~~~~~ÜÖÜXÖÖ~~~~~ÖUT T ÖP VÜ

Ü [ æ^ Ä ] á á^

Š^ à:ææ^

Öç^!^ Á^É@^!^!^!^!^!^!

## WEEKLY OR EVERY 50 HOURS

Ö: ÖT

ÜÖÜXÖÖ

ÖUT T ÖP VÜ

Ö Áæ \ Á^ áÄÜ^ æ  
Öç^!  
10 micron filterD

Öç^ \*^

Öç^ \*^ Áç^!^ Áá^ ÖÁ^ ÉÁ  
@^!^!^!^!^!^!^!^!^!  
!^ÉÁ@^!^!^!^!^!^!

Ö Šä^ Á^ á ÄÜ^!^!^!^!  
Öç^!  
10 micron filterD

Öç^ \*^

Öç^ \*^ Áç^!^ Áá^ ÖÁ^ É  
@^!^!^!^!^!^!^!^!^!  
!^ÉÁ@^!^!^!^!^!^!

## MONTHLY OR EVERY 150 HOURS

ITEM

SERVICE

COMMENTS

P^ á:æ |æÜ^ æ Š^ç^!^!

Öç^ &

Öáá^ Á^!^!^!^!

P^ áÄÜæ \ Á^!^!^!^!

Ö!^æ |@& |æ^ |æ^

Ö!^æ |!^!^!^!^!^!  
^!^!^!^!^!^!^!^!

Ü^æ Á^!^!^!^!  
| | @ @ Ü H  
F | È È |  
F | È È |

T æ Á È È È  
~~~~~G  
~~~~~G  
~~~~~G

## YEARLY OR EVERY 500 HOURS

ITEM

SERVICE

COMMENTS

Ü ] á á^!^!^!^!  
P^ áÄÜæ \ Á^!^!^!^!  
Ö Áæ \ Á^ áÄÜ^ æ Öç^!  
10 micron filterD

Öç^ \*^  
Öç^ \*^  
Öç^ \*^

Ö Šä^ Á^!^!^!^!  
10 micron filterD

Öç^ \*^ ~~~~!

Öç^ \*^!^ @ } á áææ^ á  
á^ Á^!^!^!^!^!^!^!^!^!

P^ áÄÜæ \ Á^!^!^!^!

Öç^ \*^

Ö [ {





T æ ç } æ &^ Á^!^!^!^!^!^!^!^!





# MAINTENANCE

MAINTENANCE

| Torque for Standard Fasteners |                  |                                                                                           |            |           |                                                                                           |            |            |                                                                                           |            |            |                                                                                             |            |            |  |          |  |  |
|-------------------------------|------------------|-------------------------------------------------------------------------------------------|------------|-----------|-------------------------------------------------------------------------------------------|------------|------------|-------------------------------------------------------------------------------------------|------------|------------|---------------------------------------------------------------------------------------------|------------|------------|--|----------|--|--|
| Nominal Dia.<br>(in.)         | threads per inch |  Grade 2 |            |           |  Grade 5 |            |            |  Grade 8 |            |            |  Grade 9 |            |            |  |          |  |  |
|                               |                  | Tightening Torque                                                                         |            |           | Tightening Torque                                                                         |            |            | Tightening Torque                                                                         |            |            | Tightening Torque                                                                           |            |            |  |          |  |  |
|                               |                  | Lubed                                                                                     | Dry Plated | Dry plain | Lubed                                                                                     | Dry Plated | Dry plain  | Lubed                                                                                     | Dry Plated | Dry plain  | Lubed                                                                                       | Dry Plated | Dry plain  |  |          |  |  |
| K = 0.15                      |                  |                                                                                           | K = 0.17   |           |                                                                                           | K = 0.20   |            |                                                                                           | K = 0.15   |            |                                                                                             | K = 0.17   |            |  | K = 0.20 |  |  |
| Unified Coarse Thread Series  |                  |                                                                                           |            |           |                                                                                           |            |            |                                                                                           |            |            |                                                                                             |            |            |  |          |  |  |
| 1/4                           | 20               | 49 in-lbs                                                                                 | 59 in-lbs  | 66 in-lbs | 76 in-lbs                                                                                 | 86 in-lbs  | 101 in-lbs | 107 in-lbs                                                                                | 122 in-lbs | 143 in-lbs | 126 in-lbs                                                                                  | 143 in-lbs | 168 in-lbs |  |          |  |  |
| 5/16                          | 18               | 101                                                                                       | 122        | 135       | 157                                                                                       | 178        | 209        | 221                                                                                       | 251        | 295        | 259                                                                                         | 294        | 346        |  |          |  |  |
| 3/8                           | 16               | 15 ft-lbs                                                                                 | 18 ft-lbs  | 20 ft-lbs | 23 ft-lbs                                                                                 | 26 ft-lbs  | 31 ft-lbs  | 33 ft-lbs                                                                                 | 37 ft-lbs  | 44 ft-lbs  | 38 ft-lbs                                                                                   | 43 ft-lbs  | 51 ft-lbs  |  |          |  |  |
| 7/16                          | 14               | 24                                                                                        | 29         | 32        | 37                                                                                        | 42         | 49         | 52                                                                                        | 59         | 70         | 61                                                                                          | 70         | 82         |  |          |  |  |
| 1/2                           | 13               | 37                                                                                        | 44         | 49        | 57                                                                                        | 64         | 75         | 80                                                                                        | 90         | 106        | 94                                                                                          | 106        | 125        |  |          |  |  |
| 9/16                          | 12               | 53                                                                                        | 63         | 70        | 82                                                                                        | 92         | 109        | 115                                                                                       | 130        | 154        | 135                                                                                         | 153        | 180        |  |          |  |  |
| 5/8                           | 11               | 73                                                                                        | 87         | 97        | 113                                                                                       | 128        | 150        | 159                                                                                       | 180        | 212        | 186                                                                                         | 211        | 248        |  |          |  |  |
| 3/4                           | 10               | 129                                                                                       | 155        | 172       | 200                                                                                       | 227        | 267        | 282                                                                                       | 320        | 376        | 331                                                                                         | 375        | 441        |  |          |  |  |
| 7/8                           | 9                | 125                                                                                       | 150        | 167       | 322                                                                                       | 365        | 429        | 455                                                                                       | 515        | 606        | 533                                                                                         | 604        | 710        |  |          |  |  |
| 1                             | 8                | 187                                                                                       | 225        | 250       | 483                                                                                       | 547        | 644        | 681                                                                                       | 772        | 909        | 799                                                                                         | 905        | 1065       |  |          |  |  |
| 1 1/8                         | 7                | 266                                                                                       | 319        | 354       | 596                                                                                       | 675        | 794        | 966                                                                                       | 1095       | 1288       | 1132                                                                                        | 1283       | 1510       |  |          |  |  |
| 1 1/4                         | 7                | 375                                                                                       | 450        | 500       | 840                                                                                       | 952        | 1121       | 1363                                                                                      | 1545       | 1817       | 1597                                                                                        | 1810       | 2130       |  |          |  |  |
| 1 1/2                         | 6                | 652                                                                                       | 783        | 869       | 1462                                                                                      | 1657       | 1950       | 2371                                                                                      | 2688       | 3162       | 2779                                                                                        | 3150       | 3706       |  |          |  |  |
| Fine Thread Series            |                  |                                                                                           |            |           |                                                                                           |            |            |                                                                                           |            |            |                                                                                             |            |            |  |          |  |  |
| 1/4                           | 28               | 56 in-lbs                                                                                 | 68 in-lbs  | 75 in-lbs | 87 in-lbs                                                                                 | 99 in-lbs  | 116 in-lbs | 123 in-lbs                                                                                | 139 in-lbs | 164 in-lbs | 144 in-lbs                                                                                  | 163 in-lbs | 192 in-lbs |  |          |  |  |
| 5/16                          | 24               | 112                                                                                       | 135        | 150       | 174                                                                                       | 197        | 231        | 245                                                                                       | 278        | 327        | 287                                                                                         | 325        | 383        |  |          |  |  |
| 3/8                           | 24               | 17 ft-lbs                                                                                 | 20 ft-lbs  | 23 ft-lbs | 26 ft-lbs                                                                                 | 30 ft-lbs  | 35 ft-lbs  | 37 ft-lbs                                                                                 | 42 ft-lbs  | 49 ft-lbs  | 43 ft-lbs                                                                                   | 49 ft-lbs  | 58 ft-lbs  |  |          |  |  |
| 7/16                          | 20               | 27                                                                                        | 32         | 36        | 41                                                                                        | 47         | 55         | 58                                                                                        | 66         | 78         | 68                                                                                          | 78         | 91         |  |          |  |  |
| 1/2                           | 20               | 41                                                                                        | 49         | 55        | 64                                                                                        | 72         | 85         | 90                                                                                        | 102        | 120        | 105                                                                                         | 120        | 141        |  |          |  |  |
| 9/16                          | 18               | 59                                                                                        | 71         | 78        | 91                                                                                        | 103        | 121        | 128                                                                                       | 146        | 171        | 151                                                                                         | 171        | 201        |  |          |  |  |
| 5/8                           | 18               | 82                                                                                        | 99         | 110       | 127                                                                                       | 144        | 170        | 180                                                                                       | 204        | 240        | 211                                                                                         | 239        | 281        |  |          |  |  |
| 3/4                           | 16               | 144                                                                                       | 173        | 192       | 223                                                                                       | 253        | 297        | 315                                                                                       | 357        | 420        | 369                                                                                         | 418        | 492        |  |          |  |  |
| 7/8                           | 14               | 138                                                                                       | 165        | 184       | 355                                                                                       | 403        | 474        | 502                                                                                       | 568        | 669        | 588                                                                                         | 666        | 784        |  |          |  |  |
| 1                             | 14               | 210                                                                                       | 252        | 280       | 542                                                                                       | 614        | 722        | 765                                                                                       | 867        | 1020       | 896                                                                                         | 1016       | 1195       |  |          |  |  |
| 1 1/8                         | 12               | 298                                                                                       | 357        | 397       | 668                                                                                       | 757        | 890        | 1083                                                                                      | 1227       | 1444       | 1269                                                                                        | 1439       | 1693       |  |          |  |  |
| 1 1/4                         | 12               | 415                                                                                       | 498        | 553       | 930                                                                                       | 1055       | 1241       | 1509                                                                                      | 1710       | 2012       | 1768                                                                                        | 2004       | 2358       |  |          |  |  |
| 1 1/2                         | 12               | 734                                                                                       | 880        | 978       | 1645                                                                                      | 1865       | 2194       | 2668                                                                                      | 3024       | 3557       | 3127                                                                                        | 3544       | 4169       |  |          |  |  |

Torque values for 1/4 and 5/16-in series are in inch-pounds. All other torque values are in foot-pounds. K = 0.15 for "lubricated" conditions  
 Torque values calculated from formula T=KDF, where K = 0.17 for zinc plated and dry conditions  
 K = 0.20 for plain and dry conditions D = Nominal Diameter  
 F = Clamp Load

| Torque-Tension Relationship for Metric Fasteners |       |                   |            |           |                   |            |           |                   |            |           |                   |           |  |
|--------------------------------------------------|-------|-------------------|------------|-----------|-------------------|------------|-----------|-------------------|------------|-----------|-------------------|-----------|--|
| Nominal Dia.<br>(mm)                             | Pitch | Class 4.6         |            |           | Class 8.8         |            |           | Class 10.9        |            |           | Class 12.9        |           |  |
|                                                  |       | Tightening Torque |            |           | Tightening Torque |            |           | Tightening Torque |            |           | Tightening Torque |           |  |
|                                                  |       | Lubed             | Dry Plated | Dry plain | Lubed             | Dry Plated | Dry plain | Lubed             | Dry Plated | Dry plain | Lubed             | Dry plain |  |
| K = 0.15                                         |       |                   | K = 0.17   |           |                   | K = 0.20   |           |                   | K = 0.15   |           |                   | K = 0.20  |  |
| 3                                                | 0.5   | 0.28              | 0.32       | 0.38      | 0.73              | 0.82       | 0.97      | 1.0               | 1.2        | 1.4       | 1.2               | 1.6       |  |
| 3.5                                              | 0.6   | 0.44              | 0.50       | 0.59      | 1.1               | 1.3        | 1.5       | 1.6               | 1.9        | 2.2       | 1.9               | 2.5       |  |
| 4                                                | 0.7   | 0.66              | 0.74       | 0.87      | 1.7               | 1.9        | 2.3       | 2.4               | 2.7        | 3.2       | 2.8               | 3.8       |  |
| 5                                                | 0.8   | 1.3               | 1.5        | 1.8       | 3.4               | 3.9        | 4.5       | 4.9               | 5.5        | 6.5       | 5.7               | 7.6       |  |
| 6                                                | 1     | 2.3               | 2.6        | 3.0       | 5.8               | 6.6        | 7.7       | 8.3               | 9.4        | 11        | 9.7               | 13        |  |
| 6                                                | 1.25  | 2.1               | 2.3        | 2.7       | 5.3               | 6.0        | 7.0       | 7.6               | 8.6        | 10        | 8.8               | 12        |  |
| 7                                                | 1     | 3.8               | 4.3        | 5.0       | 9.7               | 11         | 13        | 14                | 16         | 19        | 16                | 22        |  |
| 8                                                | 1     | 5.9               | 6.6        | 7.8       | 15                | 17         | 20        | 22                | 24         | 29        | 25                | 34        |  |
| 8                                                | 1.25  | 5.5               | 6.2        | 7.3       | 14                | 16         | 19        | 20                | 23         | 27        | 24                | 31        |  |
| 10                                               | 1.25  | 11                | 13         | 15        | 29                | 33         | 39        | 42                | 48         | 56        | 49                | 66        |  |
| 10                                               | 1.5   | 11                | 12         | 14        | 28                | 32         | 37        | 40                | 45         | 53        | 47                | 62        |  |
| 12                                               | 1.25  | 21                | 23         | 28        | 53                | 60         | 71        | 76                | 86         | 101       | 89                | 119       |  |
| 12                                               | 1.5   | 20                | 22         | 26        | 51                | 58         | 68        | 73                | 82         | 97        | 85                | 113       |  |
| 12                                               | 1.75  | 19                | 21         | 25        | 49                | 55         | 65        | 70                | 79         | 93        | 81                | 108       |  |
| 14                                               | 1.25  | 26                | 29         | 34        | 66                | 75         | 89        | 95                | 108        | 127       | 111               | 148       |  |
| 14                                               | 1.5   | 28                | 32         | 37        | 72                | 82         | 96        | 103               | 117        | 138       | 121               | 161       |  |
| 14                                               | 2     | 30                | 34         | 40        | 78                | 88         | 104       | 111               | 126        | 148       | 130               | 173       |  |
| 16                                               | 1.5   | 50                | 57         | 67        | 129               | 146        | 171       | 184               | 208        | 245       | 215               | 287       |  |
| 16                                               | 2     | 47                | 53         | 62        | 121               | 137        | 161       | 173               | 196        | 230       | 202               | 269       |  |
| 18                                               | 1.5   | 73                | 82         | 97        | 187               | 212        | 249       | 268               | 303        | 357       | 313               | 417       |  |
| 18                                               | 2.5   | 65                | 73         | 86        | 167               | 189        | 222       | 239               | 270        | 318       | 279               | 372       |  |
| 20                                               | 1.5   | 101               | 115        | 135       | 270               | 306        | 360       | 374               | 424        | 498       | 437               | 583       |  |
| 20                                               | 2.5   | 91                | 104        | 122       | 236               | 267        | 314       | 337               | 382        | 449       | 394               | 525       |  |

Clamp load calculated as 75% of the proof load for specified bolts. K = 0.15 for "lubricated" conditions  
 All torque values are listed in foot-pounds K = 0.17 for zinc plated, dry conditions  
 Torque values calculated from formula T=KDF, where K = 0.20 for plain and dry conditions D = Nominal Diameter  
 F = Clamp Load

©

T



# MAINTENANCE

## LUBRICATION RECOMMENDATIONS

**MAINTENANCE**

| Description                                                        | Application    | General Specification                              | Recommended Mobil Lubricant           |
|--------------------------------------------------------------------|----------------|----------------------------------------------------|---------------------------------------|
| Viædq  P^ â!æ  æ•Á                                                 | Ü^•^!ç[ ä      | RÖËËÖ<br>T ØÄ FFHÍ Ê FFI F<br>ØPT GÖFHÍ ÖÇØPGEFD   | T [ àã~ æÁ G                          |
| T [ , ^!P^ â!æ  æ•<br>Ö [  âÁ^ { } ^!æ  ^•Æ<br>ÜæðM                | Ü^•^!ç[ ä      | ØUÁÍ ÁÇ æY ^æË , Á^ { }                            | T [ àãÖVÒFI T                         |
| P [ { æÁ^ { } ^!æ  ^•<br>F »ÁÜæðM                                  | Ü^•^!ç[ ä      | RÖËËÖ<br>T ØÄ FFHÍ Ê FFI F<br>ØPÁT GÖFHÍ ÖÇØPGEFD  | T [ àã~ æÁ G Á                        |
| P [ { æÁ^ { } ^!æ  ^•Á<br>FÍ »ÁÜæðM                                | Ü^•^!ç[ ä      | ØUÁÍ ÁÇ æY ^æ                                      | T [ àãÖVÒÁG                           |
| P ä @Á ] ^!æ * Á^ { } É<br>Öä [ ç^ÁÉ»Ø                             | Ü^•^!ç[ ä      | ØUÁÍ ÁÇ æY ^æ                                      | T [ àãÖVÒFI T                         |
| ØæÁÜæÖ^æà [ ç<br>Ü^•^!ç[ ä                                         | Ü^•^!ç[ ä      | ÜÖÜÁ^ } @æÖçd^ { ^<br>Ü!^•~  ^ÁÖ^æS^ à^            | T [ àãÜPÖÁÍ Y ÈÉ<br>T [ àãÁÜ^ } @æÖ^æ |
| Ö^ æ!ÁÜ @æBÁÖ [ ~ } á<br>Ü [  ^!ÁÜ @æçD Ö^ }                       | Ö!^æ^<br>Ö^ }  | Šæ { Ö [ { }  ^ç<br>Öçd^ { ^Á!^•~  ^<br>P SÖÖÜÁGE  | T [ àã~  ^æ^ÁÖT ÈÜ                    |
| Ö!æÁÜ @æÖ [ ~ }  ^!<br>Çæ!æ áÁÜ [ æ^ D                             | Ö!^æ^<br>Ö^ }  | Šæ { Ö [ { }  ^ç<br>Öçd^ { ^Á!^•~  ^<br>P SÖÖÜÁGE  | T [ àã~  ^æ^ÁÖT ÈÜ                    |
| Ö!æÁÜ @æÄ [ \^É<br>WÈ ä çBÁÜc àÁÜ@ec                               | Ö!^æ^<br>Ö^ }  | Šæ { Ö [ { }  ^ç<br>Öçd^ { ^Á!^•~  ^<br>P SÖÖÜÁGE  | T [ àã~  ^æ^ÁÖT ÈÜ                    |
| Ö [ { { ÁÜ, æ  <br>Ö [ { { Ö^   ä^!ÁÜæ [ ç<br>Ç [ æ^ BÁÜæÖ [ { D   | Ö!^æ^Á<br>Ö^ } | Šæ { Ö [ { }  ^ç<br>Öçd^ { ^Á!^•~  ^<br>P SÖÖÜÁGEÁ | T [ àã~  ^æ^ÁÖT ÈÜ                    |
| Ö^ & ÁÖ [ { { ÁÜæ [ çB<br>Ö^ & ÁÜç ] ÁÜæ • ç ^ } c<br>Ü [ æ^ BÁÜæD | Ö!^æ^<br>Ö^ }  | Šæ { Ö [ { }  ^ç<br>Öçd^ { ^Á!^•~  ^<br>P SÖÖÜÁGEÁ | T [ àã~  ^æ^ÁÖT ÈÜ                    |
| Ö^ & ÁÜ ] ä^!ç [ ç^ D                                              | Ö!^æ^<br>Ö^ }  | Vä^!ÁÜ ] ä^!S^ à!æç c<br>] æç^ { à^!ÁÜ     ÉÉÉÉ    | T [ àãÜPÖÁÇGE                         |

Ö [ { T æ ç } æ & ÁÜ^æç } Á È

# MAINTENANCE

# MAINTENANCE

## POLYCARBONATE CARE AND MAINTENANCE

V@Á:]|:]i@d^ÁVXÁñ áÁÖá:æ q } ÁÙ^•ã çá OÙ~|-æÁ&[ æã \* Á [ ] ÁÙPÖSÖUÁÙWÚÖÜÓUÖE/ÖÖÁ [ | ^ &æà [ ] æ  
 •ã ) äæ ç d^ Á [ ] | : Ç^•Á^+|+| ç & ËÙ^iã áæÁ&^ çã ã \* Á • ã \* Á | [ ] ^!Á | [ ] &^!^• Á çã áÁ& [ ] æã^Á&^ çã ^! • Á ç^!  
 ^& [ { { ^ } á^áÁ Á | [ [ ] \* Á ^! çã Áã ËV/ã ^! ÁÖ | [ ] Ë [ | ^ &æà [ ] æ^Á ÁÙWÚÖÜÓUÖE/ÖÖÁ ] Á [ Ö Á ã^• É

ÖSÖÇP Ö ÖÁ/PÖÁÙWÚÖÜÓUÖE/Á ÖÜÖËÖUÖE/

- FÈ Y æ Ö á äçã ãáÁ | ^ ç ] Á - Á [ çã Á | Á^ç!^• ^ } çã ãÁ^ \ ^, çã Á æ!É
- GÈ W ç \* Á Á [ - & [ Ö Á | Á [ ] \* ^ È^• } d^ Á ç Ö Ö Á @ ^ Ö Á [ ( • ^ ) Á á çã áÁ iã ^ Á çã áÁ ç • Á ^ | Á äçã çã Á , æ!É
- HÈ V | Á ^ Ç^• } Ö æ!Á [ çã \* È Ç | ^ ~ Ç Á i^ Á äçã çã [ á Á | Á^ | [ ( • Á | ) [ ] \* ^ È
- I È Öç [ á Á Ö Á • Á Á çã ã Á Á çã ^! • È ~ ^^• ^^ • Á çã á D | Á ç Ö | Á ^ çã ã \* Á [ ] | ^ ( ^ ) Ç Á çã ç Á ç Á Á \* [ ~ • Á Ö Á çã \* È

ÖSÖÇP Ö ÖÁ Ö Ö P VUÁ Y P Ö P Á P Ö Ç Ö Á Ö Ö Ö P Á Ö U W P Ö Á V U Á Ö Ö Á Ö U T Ú Ö E / Ö S Ö Á W P Ö Ö Ü Á S Ö Ç Ö U Ö Ö U Ö Ü Ö U P Ö Q W P Ö U K

Ö^ \ ^ • Á | [ ^ ] • Á - Á [ çã • Á çã áÁ Ö^ç!^• ^ } Ç

|                      |                    |                 |                           |
|----------------------|--------------------|-----------------|---------------------------|
| Y á á^ÇFD            | V [ ] Á á ç        | R ^ ÇD          | T   Á Ö   ç ç             |
| Ö ç ç ç ç D          | Ö   { ~   çã E Ç D | Ù ~ { çã Ö Ö FG | Ó ~ & á^ & ã              |
| U! * ç ç Á   Ç^• Ç   |                    |                 |                           |
| Ö^ ç   Á Ö   [   Ç^• | S^   ( • ^ ) ^     | P^ Ç^   Ö Ö Ö Á | P ç ç ç XT B U Á : çã ^ D |
| P^ ^ & È   çã        | V ! & Á E G        |                 |                           |
| Ö & Ç                |                    |                 |                           |
| T ^ Ö ç [            | Ö [ ] [ ] ^        |                 |                           |

Ö Á Á • ã ~ çã i^ çã çã Á [ Ç^• } Ç Á Ö ~ | á Á Á^ \ ( [ Ç^• á Á äçã Á & ] } á ç ^ Á ç • Á È

## GRAFFITI REMOVAL

Ö^ ç | Á Ö | [ | Ç^• Á Ç^• | Á \ ( [ Ç^• Á - Á çã Ç È çã çã \* Á ^ } Á \ • È çã • çã È Á çã Ë V @ Á • Á - Á çã çã \* Á çã ^ È çã Ç • çã Á çã ^ | Á çã Ö Á \ ( [ Ç^• Á [ ] • Á [ ] | Á ^ Á | Á çã çã \* Á - Á | á Á ^ çã @ ^ á Á çã Ç • È

V | Á \ ( [ Ç^• Á çã ^! • È çã ^! • È çã È Ö Á • Á - Á ^ | ( • ^ ) ^ Á | Á XT B U Á çã çã çã Á \ ^ çã Á - Á çã È V @ Á Ö Á | Ç^• Ç , á Á | Ç^• Á ^ çã Á çã Á Á çã ^! • È çã ] | Á çã Ö Á ^ | Á D Á [ - ç ) Á Ö Á çã Ç • çã Á çã á Á | [ ( [ Ç^• Á \ ( [ Ç^• Á È

Ö Ü Ö Ü Ö Ü V Ö Ç Ö Á çã çã Á • Á ^ ~ } á Á Ç Á á Á & [ ] æã^Á çã Á çã Ç | Ö^ | Á Ö • Ö È Á á Á • çã Á Á Á ^ } á Á Á Á çã & [ ] æã^Á Á Ö Á Á | á È V @ Á } Ç^• Á • Á Ö Ç , ^ Ç^• È Á [ Á çã çã • Á ~ ^ È Ç çã | çã | Á ^ + | : çã & Á Á [ Á ~ çã çã Ç çã çã Á ] á È • Á & [ ] á äã } • Á çã Á ^ } Á ] | çã á È V @ | ^ + | Á È Ö • Á Á • | Ç Á Ö ~ | á Á Á • Á á Á çã çã Á | ^ çã á Á Á | á & [ { { ^ } á á Á çã Ö Á • Á Á • Á Ö Á | [ á ~ & Ö Á ] á Á çã çã Á ] á È • Á & [ ] á äã } • È

Ö [ { T çã çã } çã & Á Á ^ çã ] Á È €

# MAINTENANCE

MAINTENANCE

## RECOMMENDED FILLING INSTRUCTIONS FOR HYDRAULIC RESERVOIRS

Y @ } Áqj \* Á! & @ & q \* Á @ Á qÁ ç^ | É @ Á } qÁ @ ~ | á Á q á^ á Á } Á qÁ ç^ | Á ~ | á É @ Á U O O Á q á Á q | ,  
 • ~ á a } qÁ ^ Á q Á q | | Á q Á q á a } qÁ { ] ^ á : ^ É V ^  
 & á q } Á @ } Á ^ { [ ç q \* Á @ Á ] ^ • • ~ | á á Á á | á @ : É  
 Ö | Á ] [ q ] á Á q á q ^ Á [ ] ^ } q \* Á @ } Á ^ { [ ç q \*  
 á | á @ : É

QÁ ~ | Á ^ • Á ç q | Á @ Á } Á q @ Á \* | á • • Á Á V @  
 ! ^ • Á ç q | Á @ ~ | á Á Á q | á Á q Á @ Á q ] Á - Á @ Á [ , ^  
 • á @ Á q • Á } Á @ Á q á Á - Á @ Á q \ É Ö | Á [ q ç | q | É  
 V @ Á ^ • Á ç [ á Á @ Á ^ ] Á ç | q | á Á @ } Á q Á q á q |  
 q Á @ Á ] ^ | Á q @ Á q • É Á q \ Á @ Á [ Á ~ & q q É @ Á q & • •  
 ^ ç & • Á q á Á Á q | | á Á @ ~ \* @ Á ] ! ^ • • ~ | á á Á | á @ : É

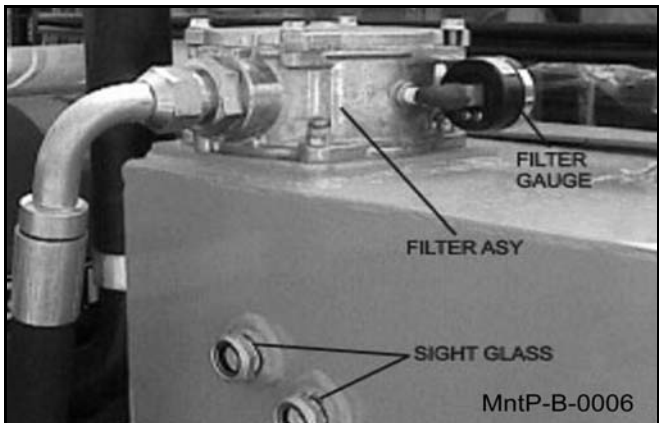

QÁ ~ | Á ^ • Á ç q | Á @ Á } Á q @ Á \* | á • • Á Á V @  
 \* á Á Á V @ Á ^ • Á ç q | Á @ ~ | á Á Á q | á Á q Á @ Á q } q |  
 [ - Á @ Á q @ Á q • Á } Á @ Á q á Á - Á @ Á q \ É Ö | Á [ c  
 [ ç | É q | É q @ Á q \ Á @ Á [ Á ~ & q q É @ Á q & • •  
 { á Á Á q | | á Á @ ~ \* @ Á ] ! ^ • • ~ | á á Á | á @ : É

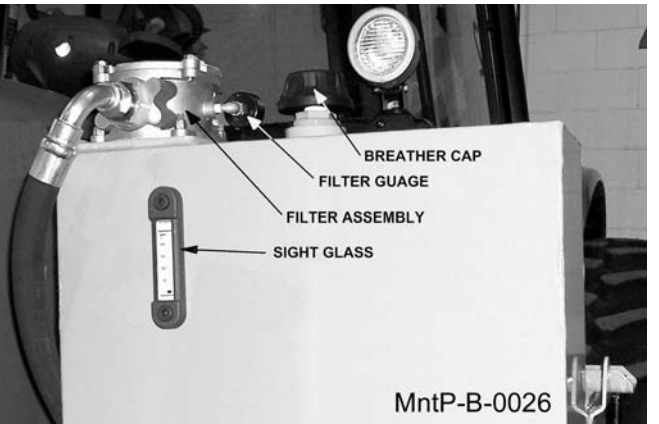

## DETAILED MAINTENANCE

Ü Ö U S Ö Ö Ö Ö Á É Ö Ç S Á P Y Ö Ü Ç V S Ö Á Z S V Ö Ü K  
 Š [ ^ ] Á @ Á } Á q | | Á q } Á @ Á q ] Á q ç | Á - Á @ Á q |  
 @ ~ q \* É V ! } Á q | Á q } q | É [ & , á Á } q | Á q  
 ^ Á É Ü ^ { [ ç Á q á Á ] á Á q | É Ü ^ | á Á q ] Á q ç |  
 q á Á q ç | Á q | | q Á ] [ • á Á | á Á q Á ^ { [ ç á É



Ö [ { T q ç } q & Á ^ & q } Á É F



# MAINTENANCE

MAINTENANCE

## GREASING GROUND ROLLER SHAFT-- FLAIL

Š[ &æ^Á^i^æ^Á^i\•Á } Áæ& Á } áÁ -Á[ ||^i^Á^ à^Áæ  
 ||, ^i^Á } áÁ -Á@æ& [ i{ æ& [ } ááá } •Á^~ á^Á } ^Á^i  
 ç [ Á^~ { } •Á^æ&@Á^æ& \* Á^ •á \* Á^æ& { É[ { } ]^ç  
 Öçd^ { ^Á^i^æ^Á^i } i{ á \* Á^ Á^ SÖ ÇÉU  
 HGEÁ ] ^ááæ& } •ÉV@Á^áÁq Á^Á^ [ ] ^Á, á@æ  
 •æ } ááá^i^æ^Á^i } Ááá^ Á^ Á^ 8 hour intervals.  
**CAUTION:** Over greasing may cause premature  
 seal failure



## ADJUSTING/CHECKING BELT TENSION

V[ Ááá^ •ç^i^ç^ } •á } Á^i^Á^ |æ& Á^i^ç^ } Á^áá^æ^ ç^i  
 @æ& É^ [ ç^Á^ ~i^Á^ |ç^ç^Á^ & i^Á^ç^ç^i^ç^ ç^i  
 æ } áÁ^ [ ç^Á^ ç^i^ÉV@Á^ç^Á^ •Á^ç^ } Á^i^ [ , Áæ&  
 à^Ááá^ •ç^áÁq Á^ & i^æ^É^ & i^æ^Á^ç^ç^i^ç^ } •á }  
 æ } Á^á^á^É^ç^UVÓÁ^Š[ &æ& } Á^ Ááá^ •ç^ } ç^i^ç^  
 { æ } ç^ç^ Á^ } Á^áá^æ^ ç^i^Á^ç^ç^ •É Be sure to replace  
 the belt cover BEFORE operating mower!

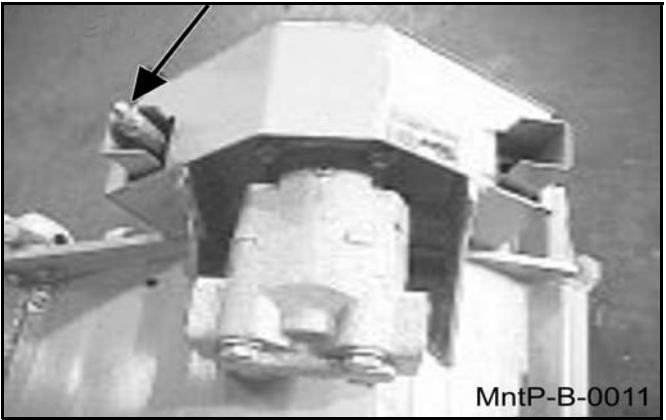

## TIGHTENING KNIFE BOLTS AND DISK BOLTS:

Çç^i^Á^ç^i^ Á^ç^i^ •Á^ -Á^ ]^i^æ& } Á^i^Ááá^ É^ç^Á^ } á^  
 Ó [ ç^ç^ ááá^ \Á^ |ç^Á^ç^ |á^Á^á^ ç^ } ^áá^ Á^ || , •K  
 S) á^Á^ [ ~ ] ç^ \* Á^ |ç^Á^i^~^Á^ Á^É^Á^ á^i^æ& á^Á^ç^á^ •É  
 Öç \Á^ [ ~ ] ç^ \* Á^ |ç^Á^ç^ç^i^~^Á^ Á^ç^i^Á^i^Á^i^Á^i^É  
 |~á^i^æ& á^Á^ç^á^ •É



Ó [ { T æ ç } æ & Á^i^ç^ } Á^É^H

# MAINTENANCE

MAINTENANCE

## GREASING POINTS ON BOOM AND PIVOT

Š[ &æ^Á^!^æ^Á^!^•Á^} Á^&Á^ Á^ [ ó^•^ à^'É] Á^@  
á^&Á^} á^Á^ Á^&Á^} á^æ^ Á^[[{ É^æ^Á^ æ^É^&Á^} á^æ^  
à^[[{ Á^ á^ d^æ^} á^æ^Á^, á^Á^} á^Á^ Á^ æ^ Á^[[{ É^Q^&^  
Š^æ^ { É^[[ ] Á^Á^ Ó^d^ { Á^ Ú^!^•^!^Á^!^æ^  
&Á^} -!^ { á^ Á^ Á^ Š^Ó^É^Ú^Á^H^É^Á^} ^&á^æ^} •Á^} d^  
\*!^æ^ Á^!^ á^ Á^ Á^!^ [ d^ á^Á^[[ { Á^} á^É

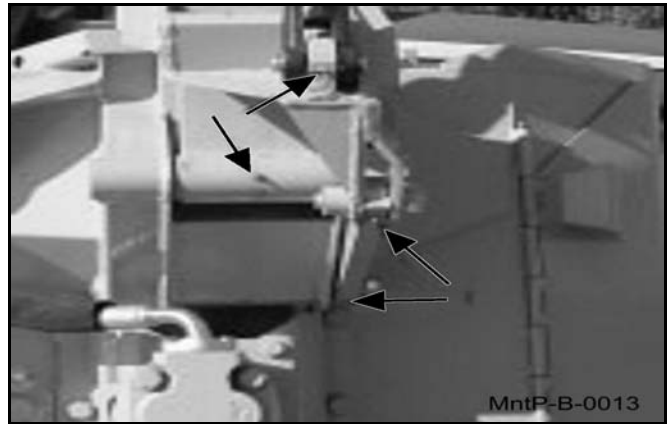

## DECK STOP ADJUSTMENT

U) Á^[[{ Á^æ^Á^[[ (•^•) Á^ & á^ Á^ d^Á^!^} Á^æ^b^•d^ ^} c  
à^ [ ó^Á^ É^æ^} á^Á^} Á^&Á^ Á^&Á^} á^ á^!^ Á^ ó^Á^ Á^ Á^Á^c^} •á^} É  
Ó^æ^b^•ó^Á^ [ ó^ Á^} d^Á^@^æ^Á^•ó^Á^} &@^ Á^@^Á^[[{ É  
æ^} á^Á^@^} Á^ [ & Á^} d^Á^

**NOTE: Bolt should not hit boom before cylinder reaches full travel.**

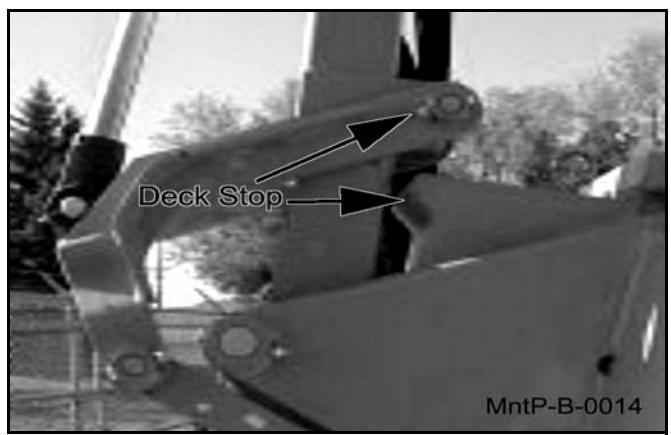

## GREASING SPINDLE

Š[ &æ^Á^!^æ^Á^!^æ^Á^!^•Á^} Á^á^•æ^Á^ Á^&Á^Á^} •á^\*É  
Q^b^&ó^ v^Á^!^Á^ Ú^} á^Á^Á^ Š^ à^!^æ^} d^Á^] æ^ó^} { à^!  
É^!^!^ É^É^É^Á^ d^ Á^] á^Á^Á^} •á^\*É^ó^Á^} á^!^æ^} c  
~} d^Á^] à^!^æ^} ó^, ^^} •Á^] ó^Á^ [ Á^] Á^} á^Á^Á^•æ^  
Š^ à^!^æ^Á^] á^Á^Á^ ^^!^ Á^!^Á^ç^!^ Á^É^Á^} •Á^ Á^•Á^É



Ó^[[{ T æ^} æ^ & Á^!^&Á^} Á^É!

# MAINTENANCE

MAINTENANCE

## TIGHTENING SPINDLE BOLTS

Verify that the spindle bolts are tightened to the correct torque. The spindle bolts are located on the rear of the spindle housing. See Figure 1 for the location of the spindle bolts.

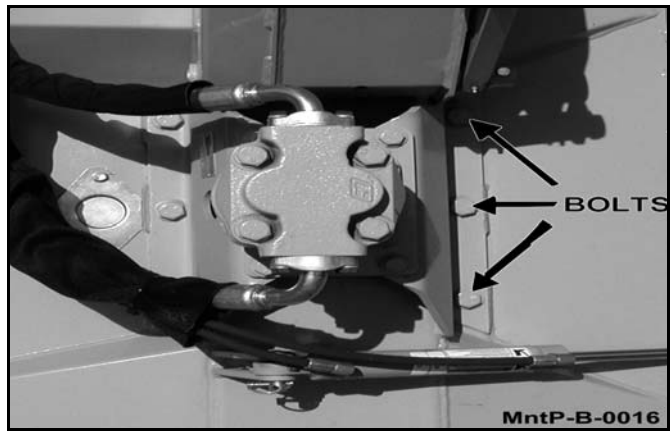

## GREASING PUMP DRIVE SHAFT COUPLER

Apply grease to the pump drive shaft coupler. The coupler is located on the front of the pump housing. See Figure 2 for the location of the coupler. Apply grease to the coupler until the grease is visible at the top of the coupler. See Figure 3 for the correct amount of grease to apply.



# MAINTENANCE

MAINTENANCE

## DRIVESHAFT YOKE, U-JOINT STUB SHAFT

Y @A ^)\* q ^A .d]] ^aEa q b&A Sa@a { Eo[ { ]|^c  
 ^cd^ ^A|^..~|^A|^ae^A&[ }-|{ q \*Aq ApSO@E@U  
 HGEA]^8aa@a} .A q A} q^i .aA q o A} aA|q A[\ ^  
 ~} qA|^ae^A&[ ]^ae .Aa@a^A^aEo|^ae^A@a{ Aa&^  
 [|Aq^i^A^Aq^i .E

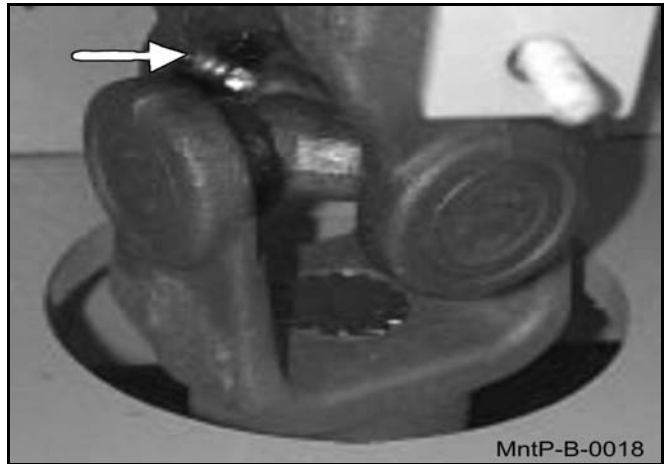

MntP-B-0018

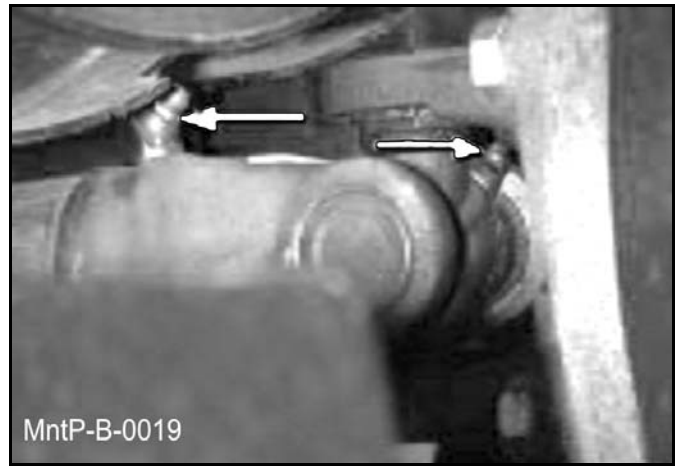

MntP-B-0019

## GREASING THE BOOM SWIVEL

S[ &ae^A@a^A: ^|\ .A[ } A@a{ aA . q^|Aa[ . .Aq  
 aq] |a@a|^D^A aA A[ [ { A] q[ aA[ . .AqAa ] |a@a|^D  
 aq aA[ ] Aa[ @A^} a .A[ -A@^Aa[ [ { A . q^|A&^ | q a^iE  
 Qb&ASa@a { Eo[ { ]|^cA@c^d^ ^A^i|^..~|^A\*|^ae^  
 &[ }-|{ q \*Aq ApSO@E@U^A^HGEA .]^8aa@a} A^} q  
 \*|^ae^A^a^\* q .Aq A[ | d^ a^A[ [ { A} a .E

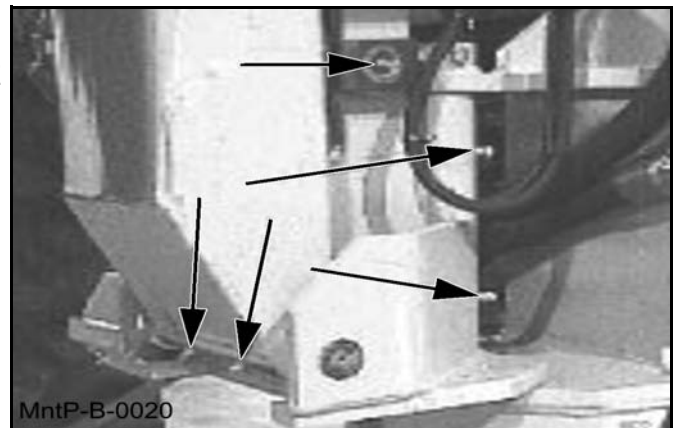

MntP-B-0020

O[ {

T aq c} aq &^A^&q } A E^i



# MAINTENANCE

MAINTENANCE

## GREASING BOOM CYLINDER(S) PIVOT POINTS

Š[ &æ^Á@Á^!\Á} Á@Á^ wÁ) áÁæ \* Á -Á& |á á^!Áæ á  
 [] Á[ áÁ) áÁæ \* ÉQb&ÁŠæ { ÉÖ[ { ]|^ÁOæd^ ^  
 Ú!^••!^Á^!^æ^Á& } f!| á \* Ád ÁpSÖÖÉUÁHGE  
 •]^&ááææ) •Á} dÁ^!^æ^Á^\* á •Áf Á!| d^ á^Á!{  
 ^) á •ÉV@ Á!| &^á^!^Á^Á Á^Á^ •^áÁ} Á@Á! æ  
 à[[ { Á& |á á^!ÉÁ •^& } áæ^ Áà[[ { Á& |á á^!ÉÁ^&  
 ] æ[ dÁæ áÁ •, æ^!Á& |á á^! •Ááæ Á! ÁæÁ Á@^!  
 á c!çæ É

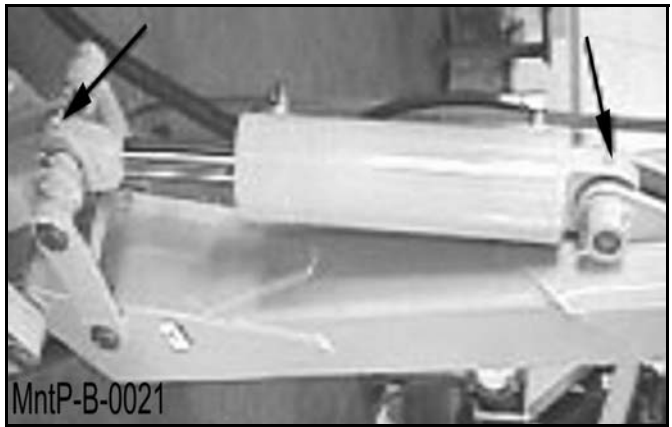

## BALL VALVES

V@ Áæ|Áçæ^ ÁæÁ@ Á@ á!æ |áÁ^•^!ç| áÁ æÁ ^^á  
 d Á^Á&| •^áÁ^ |á \* Á&!æ Á æ c) æ &Á! Á^] æ  
 ]!| &^á^! •  
**THE BALL VALVES MUST BE OPEN**  
**(handle parallel with valve) WHEN TRACTOR IS**  
**RE-STARTED OR PUMP IS COUPLED TO**  
**MOTOR OR PTO!**  
 Á@æ^!^Ád Áá[ Á [ Á] Á!^• |ç  
 &{ }[]^) Áæ^!^Á

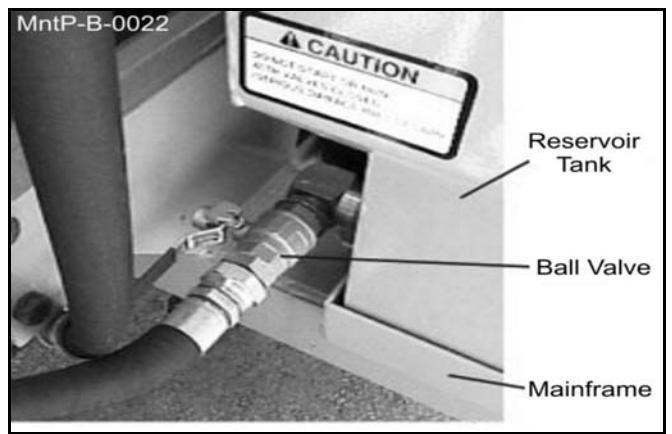

Ö[[ { T æ c) æ &Á^&á } Á Èí



# MAINTENANCE

## ROTARY KNIFE REPLACEMENT

- FÈ 0 1 2 3 4 5 6 7 8 9 10 11 12 13 14 15 16 17 18 19 20 21 22 23 24 25 26 27 28 29 30 31 32 33 34 35 36 37 38 39 40 41 42 43 44 45 46 47 48 49 50 51 52 53 54 55 56 57 58 59 60 61 62 63 64 65 66 67 68 69 70 71 72 73 74 75 76 77 78 79 80 81 82 83 84 85 86 87 88 89 90 91 92 93 94 95 96 97 98 99
- GÈ 100 101 102 103 104 105 106 107 108 109 110 111 112 113 114 115 116 117 118 119 120 121 122 123 124 125 126 127 128 129 130 131 132 133 134 135 136 137 138 139 140 141 142 143 144 145 146 147 148 149 150 151 152 153 154 155 156 157 158 159 160 161 162 163 164 165 166 167 168 169 170 171 172 173 174 175 176 177 178 179 180 181 182 183 184 185 186 187 188 189 190 191 192 193 194 195 196 197 198 199
- HÈ 200 201 202 203 204 205 206 207 208 209 210 211 212 213 214 215 216 217 218 219 220 221 222 223 224 225 226 227 228 229 230 231 232 233 234 235 236 237 238 239 240 241 242 243 244 245 246 247 248 249 250 251 252 253 254 255 256 257 258 259 260 261 262 263 264 265 266 267 268 269 270 271 272 273 274 275 276 277 278 279 280 281 282 283 284 285 286 287 288 289 290 291 292 293 294 295 296 297 298 299
- IÈ 300 301 302 303 304 305 306 307 308 309 310 311 312 313 314 315 316 317 318 319 320 321 322 323 324 325 326 327 328 329 330 331 332 333 334 335 336 337 338 339 340 341 342 343 344 345 346 347 348 349 350 351 352 353 354 355 356 357 358 359 360 361 362 363 364 365 366 367 368 369 370 371 372 373 374 375 376 377 378 379 380 381 382 383 384 385 386 387 388 389 390 391 392 393 394 395 396 397 398 399

**WARNING** WHEN CUTTING HEAVY BRUSH, KNIFE BOLTS SHOULD BE INSPECTED HOURLY AND RETORQUED TO 800 LUBRICATED FT. LBS.

## REPLACEMENT OF ROTARY DISK/BLADE BAR

**CAUTION** Failure to follow the following warnings and instructions may result in serious injury or damage to the equipment or property!

- FÈ 400 401 402 403 404 405 406 407 408 409 410 411 412 413 414 415 416 417 418 419 420 421 422 423 424 425 426 427 428 429 430 431 432 433 434 435 436 437 438 439 440 441 442 443 444 445 446 447 448 449 450 451 452 453 454 455 456 457 458 459 460 461 462 463 464 465 466 467 468 469 470 471 472 473 474 475 476 477 478 479 480 481 482 483 484 485 486 487 488 489 490 491 492 493 494 495 496 497 498 499
- GÈ 500 501 502 503 504 505 506 507 508 509 510 511 512 513 514 515 516 517 518 519 520 521 522 523 524 525 526 527 528 529 530 531 532 533 534 535 536 537 538 539 540 541 542 543 544 545 546 547 548 549 550 551 552 553 554 555 556 557 558 559 560 561 562 563 564 565 566 567 568 569 570 571 572 573 574 575 576 577 578 579 580 581 582 583 584 585 586 587 588 589 590 591 592 593 594 595 596 597 598 599
- HÈ Disks must be inspected daily for hairline cracks between spindle mounting bolts or around the knife mounting bolts. These cracks indicate metal fatigue caused by severe abuse. If cracks are present the disk must be replaced.
- IÈ 600 601 602 603 604 605 606 607 608 609 610 611 612 613 614 615 616 617 618 619 620 621 622 623 624 625 626 627 628 629 630 631 632 633 634 635 636 637 638 639 640 641 642 643 644 645 646 647 648 649 650 651 652 653 654 655 656 657 658 659 660 661 662 663 664 665 666 667 668 669 670 671 672 673 674 675 676 677 678 679 680 681 682 683 684 685 686 687 688 689 690 691 692 693 694 695 696 697 698 699
- ÍÈ 700 701 702 703 704 705 706 707 708 709 710 711 712 713 714 715 716 717 718 719 720 721 722 723 724 725 726 727 728 729 730 731 732 733 734 735 736 737 738 739 740 741 742 743 744 745 746 747 748 749 750 751 752 753 754 755 756 757 758 759 760 761 762 763 764 765 766 767 768 769 770 771 772 773 774 775 776 777 778 779 780 781 782 783 784 785 786 787 788 789 790 791 792 793 794 795 796 797 798 799

**MAINTENANCE**



# MAINTENANCE

MAINTENANCE

## Blade Pins and D-Ring Inspection

Q. ] ^ & o | a a ^ A U a . A a a O E U a \* . A a a A r | A ^ a a | A a a a e ^ A e A r || | . • A

**DANGER**

Q. ] ^ & o | a a ^ A U a . A a a O E U a \* . A a a A r | A a a } [ | { a A ^ a e A a e ^ A ^ | ^ A o | A e a | A a . A e ^ a A | a a ^ A a a A | [ ] ^ | r A | ^ a a E U O U S O O O A S O O O A U a . A a a O E U a \* . A T O O O V O S Y A A o ^ a e ^ K

- ~ X a a | ^ A e a . A |
- ~ Q a a U a A | A O E U a \* A e A a a | ^ A | | } A e ^ a e E |
- ~ Q a a U a A | A O E U a \* A e A [ ^ \* ^ A | A e | ] ^ a A e ^ a e

O a a | ^ A e A | a e ^ A a } [ | { a | ^ A | | } A a . A | A O E U a \* . A a e A a a A A e e e d [ ] @ A a a | ^ A a a A b e a } A A o A a | \ ^ } a e A e e A e e ^ A A a ^ . A [ a a A b i | A | A a e E

O e . a e A ^ | a e ^ A o | A a . A a a O E U a \* . A } ^ c | A e & . • e ^ A ^ a e A | a e a E A

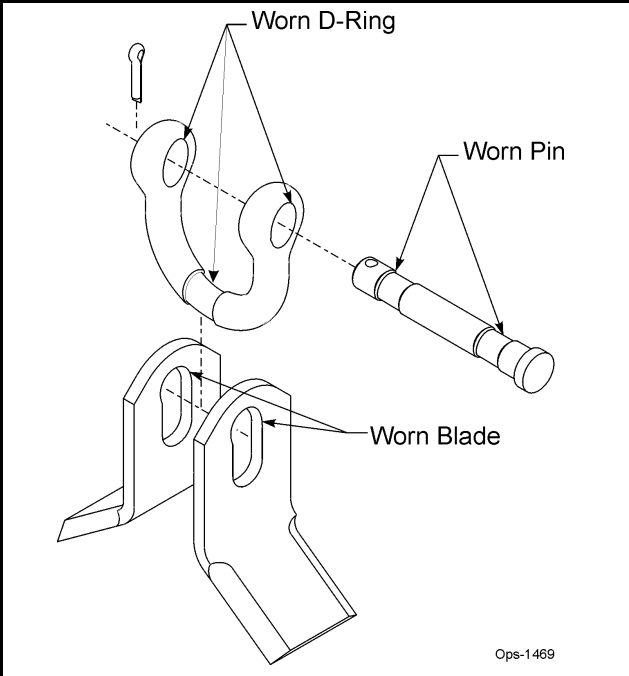

**Important**

Q o | A e a | A a . A e ^ A a | \ ^ } A e A e } a e a a e a e | a a a | a a . E A ^ [ | c ^ A o | A a a a A ^ c ^ | . ^ a e A a e a e a } A o | A a a A a . ^ | e a a e [ ^ \* @ a a O E U a \* A | A e e o | A e a | A a } A o | A | ] [ . a . a e A A o | A O E U a \* E V a A a | A ^ c ^ | a e A ^ c o ^ A o e A | a a ^ A | { A . a \* a \* A e a A a a A o a \* e | A e a | A a E A a P S - U - 0 0 4 5









# MAINTENANCE

MAINTENANCE

## 63" BOOM FLAIL KNIFE REPLACEMENT

- FÈ GÁ } ã^• Áe^Áaæ æ^áÁ! Áæáí^ Á [ ! ] Èö^ Á ã!Á ^^áÁé Áe^Á^ | æ^áÁe Áe^Á^ dÜ^ | æã \* Áeá ã \* |^Á } æ  
&æ Áæ •^Á^ç^!^Áçá!æã } Áæ áÁ [ •• ã|^Áææ æ^Áé Á@Á [ , ^!È
- GÈ OÈ •^ { à|^Á } ã^• Èè|^çã Èã [ |ø Áæ áÁ~ ø Áe Á @ , } Áæ Á æø^Á&ç } Á-Á æ~ æÈ
- HÈ Q• æ!Á! & ã \* Á@çÁ~ çÁ [ Á@æÁ@ÁæÁæ^Á-Á~ çÁ Áé , æá• Á@Á } æÈ
- I È OÈ | |^ Áç! & çÁç! FÁ! Á~ ãæ^ } çÁ Á@^æ• È
- Í È V | : ~^Á~ çÁ Á! ÁVÈSÓUÈS } æ^Á~ •ç , ã \* Á^Á^È



**DO NOT re-use the locking hex nuts for mounting the knives. If hex nut become loose, or require removal for knife replacement or any other reason, they must be discarded and replaced with new nuts.**



**Knives should not be welded on for any reason.**

## HEAVY DUTY SPINDLE ASSEMBLY INSTALLATION AND BEARING ADJUSTMENT

- WARNING!** Áç! |^•• Á WÜVÁ^Á•^áÁé Áe •æ!Áæã \* & ] • Èè^æã \* Áç! } ^• Èè áÁ^æ ÈÖUÁ^UVÁ•^Áçç { ^!  
ç Áe •æ!Áæ^ Èè^æã \* Èè! Á^æ ÈV@ÁæøÁ Áe •^ { à|^ Á æÁe^Áææ æ^áÈ
- NOTE!** Á@Á!^æ^Á^! Áæ áÁ~ ••^ø Áe^Á! &æ^áÁ } Á@Áé ] Áæ^Á-Á@Á } ã á|^Áç~ •ã \* ÈÖÁ~!^Á@Á } ã á|^Áæ  
æ•^ { à|^Áç! |^Áçç Èè
- ÓÁ~!^Áé Á^æÁ^Á! [ ç&ç! } Áæ áÁ ç@Á! [ ç&ç^Á~ ã { ^ } çÁ Á^áÁ@ } Á [ |! ã \* Á } Á } ã á|^Áæ •^ { à|^È

# MAINTENANCE

## THE SPINDLE ASSEMBLY

Ú^Á@Áæ!æÁ^[[, Á!Á^ cææ}Á-Á]áá^ÁæóÉ, @Á^!çæá\*É

MAINTENANCE

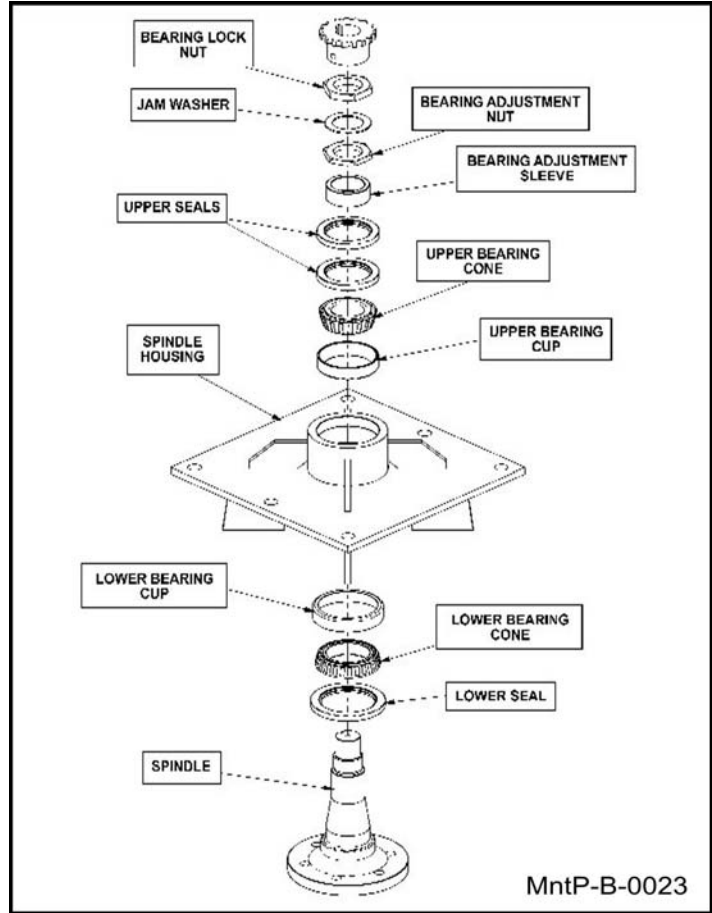

Ó[[{

Tæç}æ&Á^&ç}ÁÉ

# MAINTENANCE

MAINTENANCE

## BEARING INSTALLATION

- FÈ Úí···Á· ] ] ^í·Áà·æä \* Á& ] Á d Á@·Á·] ä á| Á @··ä \* È
  - ÇÈ V· ] Á@·Á·] ä á| Á@···ä \* Á ç·í·Áä ä Á í···Áä @·Á·, ^í·Áà·æä \* Á& ] È
  - HÈ Úí···Á·] ] ^í·Áà·æä \* Á& ] ^ Á d Á@·Á·æä \* & ] ÉÁ··ç·Á· í···Á· @·Á·æä d Á@·Á·] ä á| Á @··ä \* ÈV·@·Á·] ^í·Áä Á· Á·@·Á·æä· ·Á· ÖUY· ÉÁ·, ää· Á·@·Á·æä \* È [ Á· à·í·Áä· ç·Á·æ·á·Á· ä·Á·@·Á· @··ä \* È
  - IÈ Ç·æ·Á·@·Á·] ä á| Á·Á· Á·@·Á· @··ä \* ÈÁ·@·Á·] ] ^í···Á·@·Á·] ä á| Á·í· Á·æ·Á·@·Á·] ^ Á·] d Á·@·Á·] ä á| È
  - ÍÈ Ú· ] ] ] ] ^í·Áà·æä [ ç· { Á· Á·@·Á·] ä á| Á·ä ä Á·í···@·Á·] ] ^í·Áà·æä \* Á& ] ^ Á·ä ä Á·æä \* Áæ·á··ç· ^·} ç·Á·í·ç·Á·] d Á·@·Á·] ä á| È
- 6. NOTE: The spindle housing must turn freely when seating the bearing cone and sleeve.**
- ÏÈ Úí···Á·@·Á·] ] ^í·Áà·æä· Á· d Á·@·Á·] ä á| Á·@··ä \* ÈV·@·Á·] ^í·Áä Á· Á·@·Á·æä· Á····Á·Á·V·É·æ·Á· [ ç·@·Á·æä \* È [ Á·ç·Á··Á· à·í·Áä· ç·Á·æ·Á· È
  - ÌÈ Ç·æ·Á·@·Á·æä \* Áæ·á··ç· ^·} ç·Á·· Á·@·Á·] ·Á· [ Á·@·í·Á·Á· É·É·Á· Á·í·Á·æä & Á·Á·ç· ^·} Á·@·Á·] ç·æ·á·Á·@·Á··í·ç·Á·É·Ç·æ·Á·@·Á·æä Á·æ·@·í·Á·] ää· Á·@·Á·æä d Á·@·Á··È æ·É·Ç·æ·Á·@·Á·æä \* Á· [ & Á·· Á·@·Á·] ·Á·æ·á·Á·@·Á·æä @·Á· Á·æ·á··ç· ^·} ç·Á·· ç·Á·æ·á·Á·æ·á··ç· ^·} ç·Á·· ç·Á·V·Á·@·Á·] ] ] , ä \* Á·Á·ç·] Á·í·Á·æä \* Áæ·á··ç· ^·} È
  - ÊÈ Úí···Á·] Á·@·Á·] ä á| Á·@··ä \* Á·ç·í·Á·ä [ ] ç·Á· Á· á·@·Á·æä Á·@·í·Á·] ç·á·Á·ç· É·Á·V·í·Á·æ·Á·@·Á·] \* @·Á·Á·í·, á·V·Á·í·Á·] ä á| Á·Á· à·í·Áä· ç·Á·æ·Á· { á·í·Á·í·í·É·É·É·Á·} ç·Á·@·Á·í·Á·æ·Á·] ^í·Á·Á· [ Á·@·Á·æä Á·@·í·Á·È
  - FÈÈ Ç·æ·Á·@·Á·] ·Á· d Á·@·Á·æä Á·@·í·Á·È

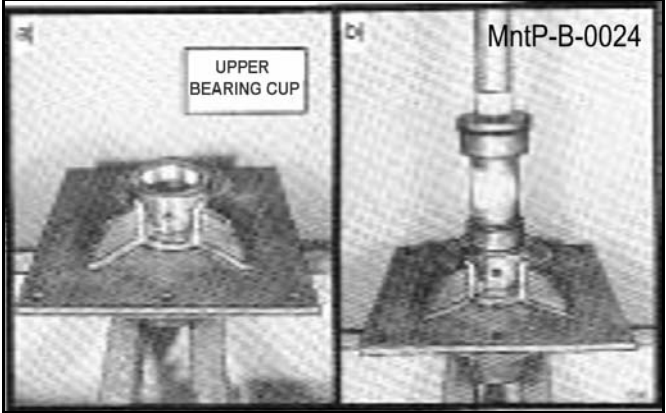

## BEARING ADJUSTMENT

- FÈ Öí·æ·] Á·@·Á·à· [ ç· { Á· ^·} ä Á· [ Á·@·Á·] ä á| Á··Á· & í·Á· Á·æä ä·Á· [ Á·@·Á·] ä á| Á·@··ä \* È ç·í·}·Á·í·Á·È
  - ÇÈ Úí···Á·] Á·æ·Á· æ· ^·ç·Á·æ·Á·æä· ä·Á·æ·Á·] ] ç·@·Á·] ç·í·Á·æä· ^·ç·Á· Á·@·Á·] ä á| Á·@··ä \* È È S· [ æ·Á·@·Á·] ä Á· Á·@·Á·æä· ä·Á·æ·Á·] Á·æ·á··ç· @·Á·æ·Á·] ä Á· Á·@·Á·] ä á| Á·@·Á·æä· ÈV·@·Á·æä ä·Á·æ·Á·] Á· ä·Á·] ] , Á· ^æ·í·Á·æ· & í·Á·í·Á·æä \* Á·] ä Á·] È
  - HÈ V·ä·@·} Á·@·Á·æä \* Áæ·á··ç· ^·} ç·Á·· ç·Á·} ç·Á· ç·@·í·Á·Á·Á·É·F·G·Á· & ç·Á· [ ç· ^·} ç·Á·, @·} Á·@·Á·] ä á| Á·@··ä \* È Á·í·Á·ä·, ää·Á·æ· æ·Á· [ ç·@·Á·æ·Á·æ· È
  - IÈ Y·@·} Á·@·í·Á·Á·É·F·G·Á· & ç·Á·í·Á·] æ·Á·Á·ç· ^·} ç·@·Á·] ä á| Á·æä ä·Á·@··ä \* È Á·æ·Á·@·Á·æä \* Á· [ & Á·· Á·@·Á·] ·Á·æ·á·Á·@·Á·æä· ç·Á· ^·} ç·Á·í·Á·æä ä·Á·@·Á·] & Á·· ç·Á· Á·É·É·É·Á·æ·Á·] ^í·Á·È
  - ÍÈ Ç·æ·Á·@·Á·] & Á·· ç·Á·Á·æ·@·} ^·Á·É·@·í·Á·] ·Á·Á·É·F·G·Á· & ç·Á·í·Á·æ·Á·] Á·æ·Á·] @·} Á·æ·@·í·Á·æ·Á·] ] Á·@·Á·] ä á| Á·@··ä \* È
- Ç·@·Á·] ä Á·] æ·Á·Á·] í·Á·æ·Á·æ·Á· & ç·Á·í·Á·æ·Á·] ä·Á·æ·Á·] Á·] Á·æ·Á· æ·@·í·Á·] í·ç·Á·} ç·@·Á·] & Á·· ç·Á· [ [ [ ··] ä \* È
- Ç·@·Á·] ä Á·] æ·Á·Á·UV·Á·] í·Á·æ·Á· [ ··] Á·@·Á·] & Á·· ç·Á·æ·á·ç·} Á·@·Á·æä· ç·Á·} ç·Á·· Á·æ·á·Á·æ·á·Á·æä· ä·Á·É·@·} Á·@· [ & Á·· ç·Á·] ^æ·Á·æ·Á·æ·Á·æ·Á·] Á·È

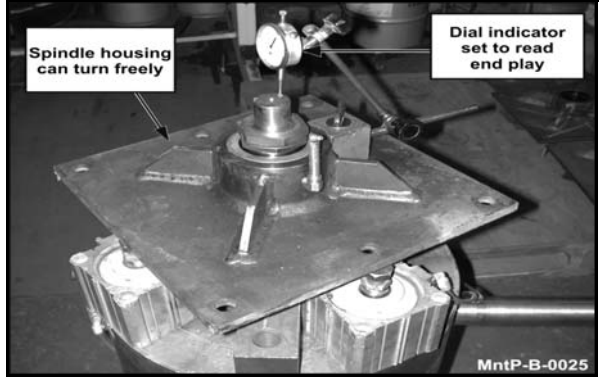

Ó [ [ T æ·ç·} æ·Á·Á·æ·ç·} Á·È





# MAINTENANCE

MAINTENANCE

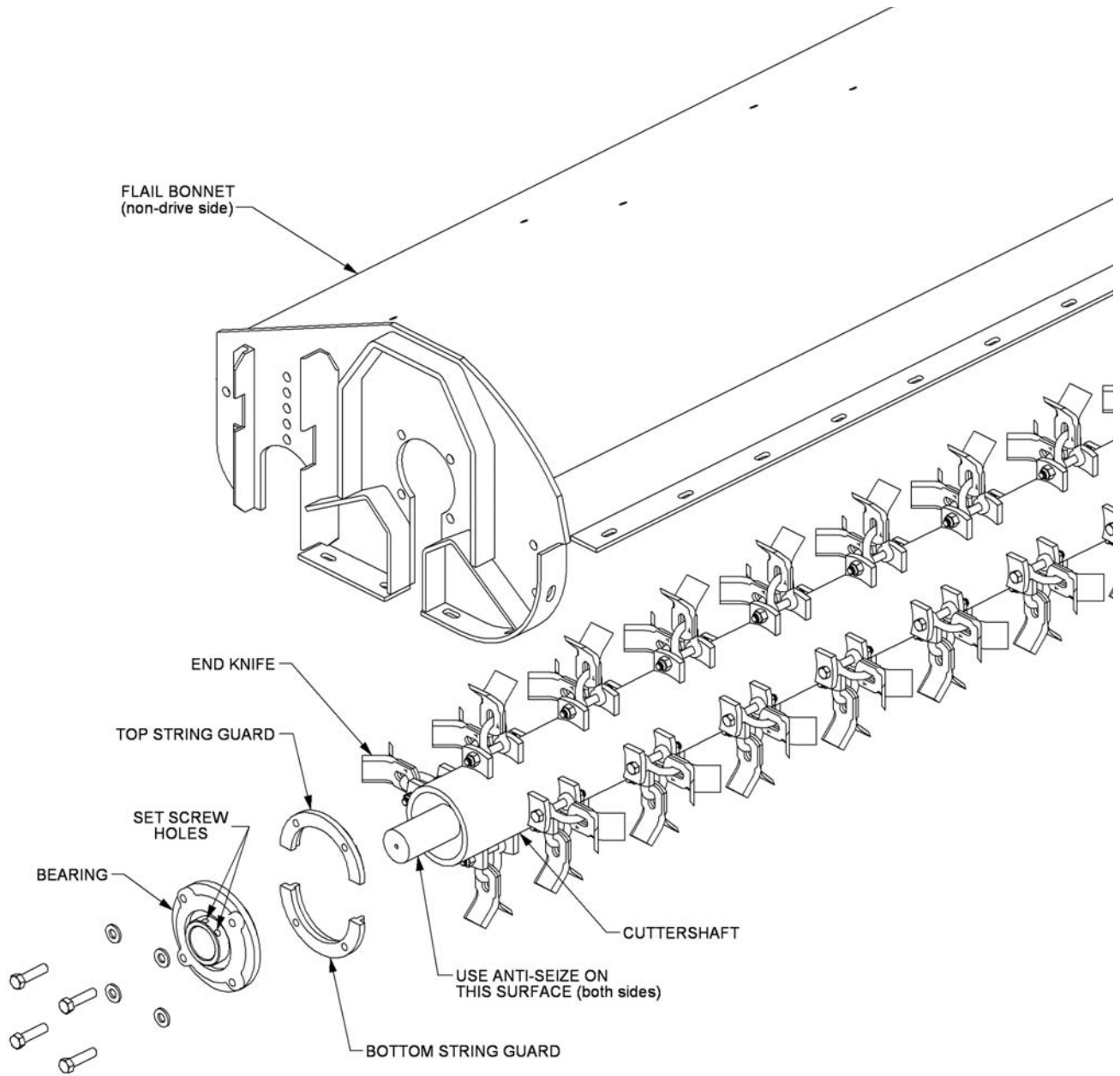



# MAINTENANCE

## MAINTENANCE

011

T a j c } a j & ^ Á ^ & a j } Á Ë G



# PARTS SECTION

# PART NAME INDEX

|                                               |    |
|-----------------------------------------------|----|
| PARTS ORDERING GUIDE.....                     | 3  |
| TRACTOR MOUNT KIT.....                        | 4  |
| TRACTOR MOUNT KIT - HYDRAULICS.....           | 6  |
| ELECTRONIC PROPORTIONAL LIFT VALVE MOUNT..... | 8  |
| JOYSTICK AND SWITCHBOX MOUNT.....             | 10 |
| BOOM MOUNT KIT.....                           | 12 |
| BOOMREST - OPEN STOW.....                     | 14 |
| FRONT AXLE STABILIZER OPTION.....             | 16 |
| POLYCARBONATE SAFETY WINDOW.....              | 18 |
| WHEEL SPACER.....                             | 19 |
| WHEEL WEIGHT.....                             | 20 |

## PARTS ORDERING GUIDE

The following instructions are offered to help eliminate needless delay and error in processing purchase orders for the equipment in this manual.

1. The Parts Section is prepared in logical sequence and grouping of parts that belong to the basic machine featured in this manual. Part Numbers and Descriptions are given to help locate the parts and quantities required.
2. The Purchase Order must indicate the **Name and Address** of the person or organization ordering the parts, **who should be charged**, and if possible, the **serial number of the machine** for which the parts are being ordered.
3. The purchase order must clearly list the **quantity of each part**, the complete and correct **part number**, and the basic **name of the part**.
4. The manufacturer reserves the right to substitute parts where applicable.
5. Some parts may be unlisted items which are special production items not normally stocked and are subject to special handling. Request a quotation for such parts before sending a purchase order.
6. The manufacturer reserves the right to change prices without prior notice.

NOTE: When ordering replacement decals, refer to the part numbers and descriptions listed in the safety section in the front of this manual.

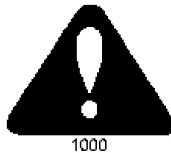

For maximum safety and to guarantee optimum product reliability, always use genuine **Tiger** replacement parts. The use of inferior replacement parts may cause premature or catastrophic failure which could result in serious injury or death.

Direct any questions regarding parts to:

**Tiger Corporation**  
3301 N. Louise Ave.  
Sioux Falls, SD 57107  
1-800-843-6849  
1-605-336-7900



## TRACTOR MOUNT KIT

**Continued...**

| <b>ITEM</b> | <b>PART NO.</b> | <b>QTY.</b> | <b>DESCRIPTION</b>         |
|-------------|-----------------|-------------|----------------------------|
| 1           | 06300381        | 1           | MAIN FRAME                 |
| 2           | 21833           | 8           | CAPSCREW,3/4" X 2-1/4",NC  |
| 3           | 21627           | 8           | NYLOCK NUT,3/8",NC         |
| 4           | 22016           | 8           | FLATWASHER,3/8"            |
| 5           | 21632           | 8           | CAPSCREW,3/8" X 1-1/2",NC  |
| 6           | 06700220        | 1           | TANK,WHEEL WELL,JD6M T4F   |
| 7           | 06505077        | 1           | CAP,BREATHER,O-RING        |
| 8           | 06505044        | 1           | FILTER,IN-TANK             |
| 9           | 6T0649          | 1           | FILTER GAUGE               |
| 10          | TF4888          | 1           | STREET ELBOW,1/8"NPT       |
| 11          | 06505127        | 1           | PLUG,#20 SAE               |
| 12          | 06505067        | 1           | SIGHT GAUGE                |
| 13          | 06300386        | 1           | AXLE BRACE,LH              |
| 14          | 06300384        | 1           | AXLE BRACE,RH              |
| 15          | 33880           | 55          | FLATWASHER,3/4",SAE        |
| 16          | 21825           | 19          | HEX NUT,3/4",NC            |
| 17          | 06510083        | 1           | BRAKE VALVE                |
| 18          | 21644           | 2           | CAPSCREW,3/8" X 5",NC      |
| 19          | 31731           | 10          | CAPSCREW,20MM X 50MM,2.5P  |
| 20          | 31722           | 4           | HEX NUT,20MM,FLNG,2.5P     |
| 21          | 21834           | 6           | CAPSCREW, 3/4" X 2-1/2" NC |
| 22          | 06402946        | 1           | UPRIGHT,LH                 |
| 23          | 34998           | 1           | SPACER,DRIVESHAFT          |
| 24          | 21989           | 4           | LOCKWASHER,7/16"           |
| 25          | 21680           | 4           | CAPSCREW,7/16" X 1-1/4",NC |
| 26          | 32691           | 4           | LOCKWASHER,10MM            |
| 27          | 23113           | 4           | CAPSCREW,10MM X 30MM,1.5P  |
| 28          | 34999           | 1           | DRIVESHAFT,U-JOINT         |
| 29          | 21733           | 4           | CAPSCREW,1/2" X 2",NC      |
| 30          | 34993           | 1           | PUMP MOUNT                 |
| 31          | 06533004        | 8           | FLATWASHER,1/2",SAE        |
| 32          | 21727           | 4           | NYLOCK NUT,1/2",NC         |
| 33          | 22014           | 1           | FLATWASHER,1/4"            |
| 34          | 32519           | 1           | WING NUT,1/4"              |
| 35          | 24860           | 4           | CAPSCREW,20MM X 40MM,2.5P  |
| 36          | 23152           | 1           | PUMP                       |
| 37          | 06412418        | 1           | TANK SUPPORT               |
| 38          | 06300383        | 1           | MNFRM MNT, JD6110M T4F     |

JD6110-30M-R BENGAL T4F

# TRACTOR MOUNT KIT - HYDRAULICS

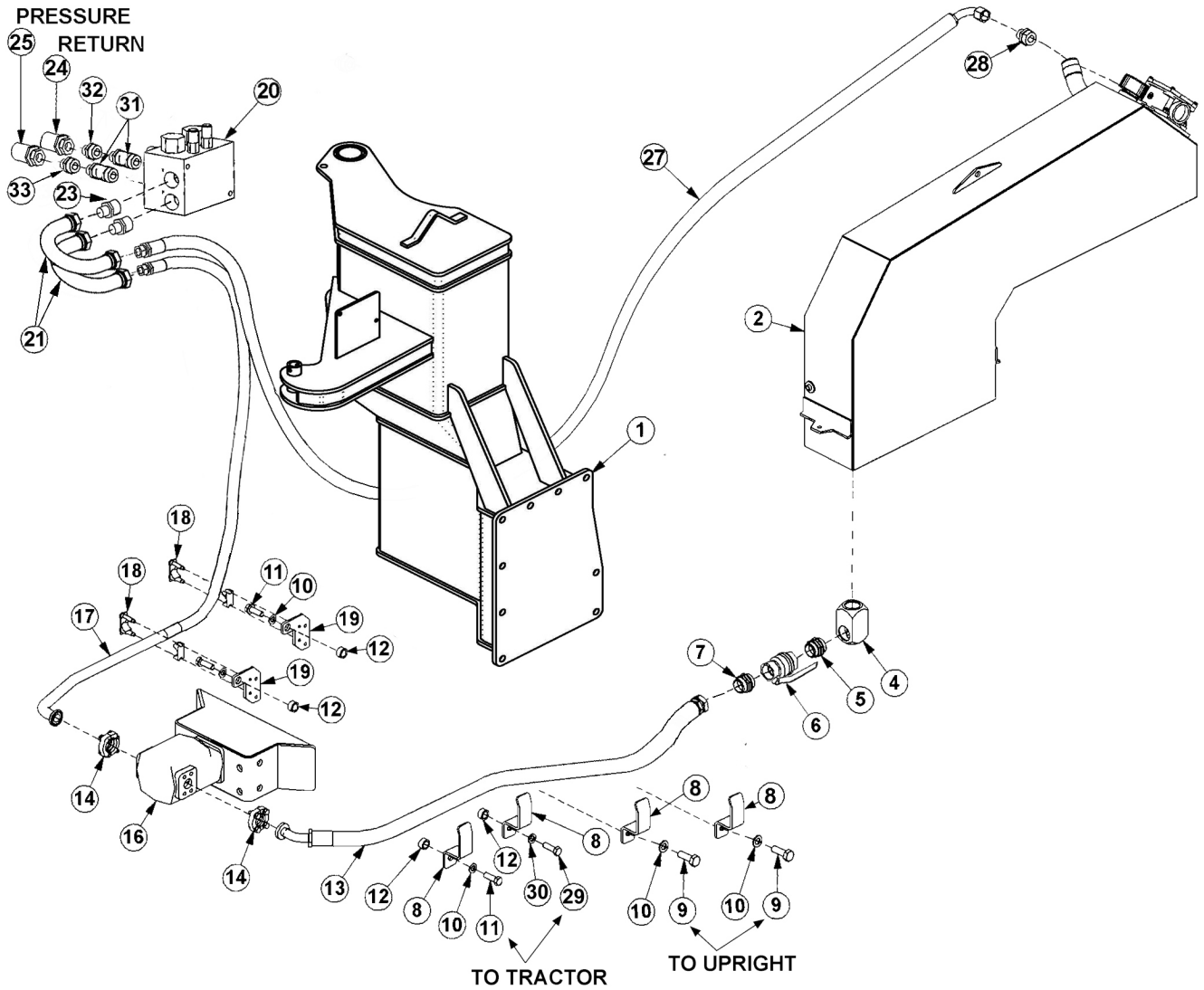

## TRACTOR MOUNT KIT - HYDRAULICS

Continued...

| ITEM | PART NO. | QTY. | DESCRIPTION                                     |
|------|----------|------|-------------------------------------------------|
| 1    | -----    | -    | MAIN FRAME *REFER TO TRACTOR MOUNT KIT PAGE     |
| 2    | -----    | -    | HYDRAULIC TANK *REFER TO TRACTOR MOUNT KIT PAGE |
| 4    | 06503084 | 1    | ELBOW,1-1/2"FOR X 1-1/2"FOR,MACH                |
| 5    | 06503083 | 1    | ADAPTER,1-1/2"MOR X 1-1/2"MOR                   |
| 6    | 34309    | 1    | BALL VALVE,1-1/2"FOR                            |
| 7    | 34710    | 1    | ADAPTER,1-1/2"MOR X 1-1/2"MJ                    |
| 8    | 32382    | 3    | BRACKET,HOSE                                    |
| 9    | 21834    | 2    | CAPSCREW, 3/4" X 2-1/2" NC                      |
| 10   | 33880    | 4    | FLATWASHER, 3/4", SAE                           |
| 11   | 30708    | 3    | CAPSCREW, 20MM X 90MM,2.5P                      |
| 12   | 24849    | 2    | SPACER                                          |
| 13   | 06500692 | 1    | HOSE,1-1/2" X 110"                              |
| 14   | TF4852   | 2    | FLANGE KIT,#20                                  |
| 16   | -----    | 1    | PUMP *REFER TO TRACTOR MOUNT KIT PAGE           |
| 17   | 06500549 | 1    | HOSE,1" X 87"                                   |
| 18   | 34076    | 1    | CLAMP KIT,1"                                    |
| 19   | 34626    | 1    | TUBE/CLAMP BRACKET                              |
| 20   | ----     | 1    | BRAKE VALVE *REFER TO TRACTOR MOUNT KIT         |
| 21   | 06506012 | 2    | U-TUBE, PREFORMED                               |
| 23   | 33555    | 2    | ADAPTER, 1MB X1MJ                               |
| 24   | ----     | 1    | HOSE,HOSE (RETURN) *REFER TO BOOM ASSEMBLY      |
| 25   | -----    | 1    | HOSE (PRESSURE) *REFER TO BOOM ASSEMBLY         |
| 27   | 06500826 | 1    | HOSE, 1" X 188"                                 |
| 28   | 34064    | 1    | ADAPTER, 1-1/4" MOR X 1" MJ                     |
| 29   | 06530819 | 1    | CAPSCREW, 12MM X 70MM                           |
| 30   | 22017    | 1    | FLATWASHER, 7/16"                               |
| 31   | 06503074 | 2    | UNION, 1" ORB X 1" ORB                          |
| 32   | 06503027 | 1    | QCK CPLR 1" FEMALE, FLAT                        |
| 33   | 06503028 | 1    | QCK CPLR, 1" MALE, FLAT                         |

# ELECTRONIC PROPORTIONAL LIFT VALVE MOUNT

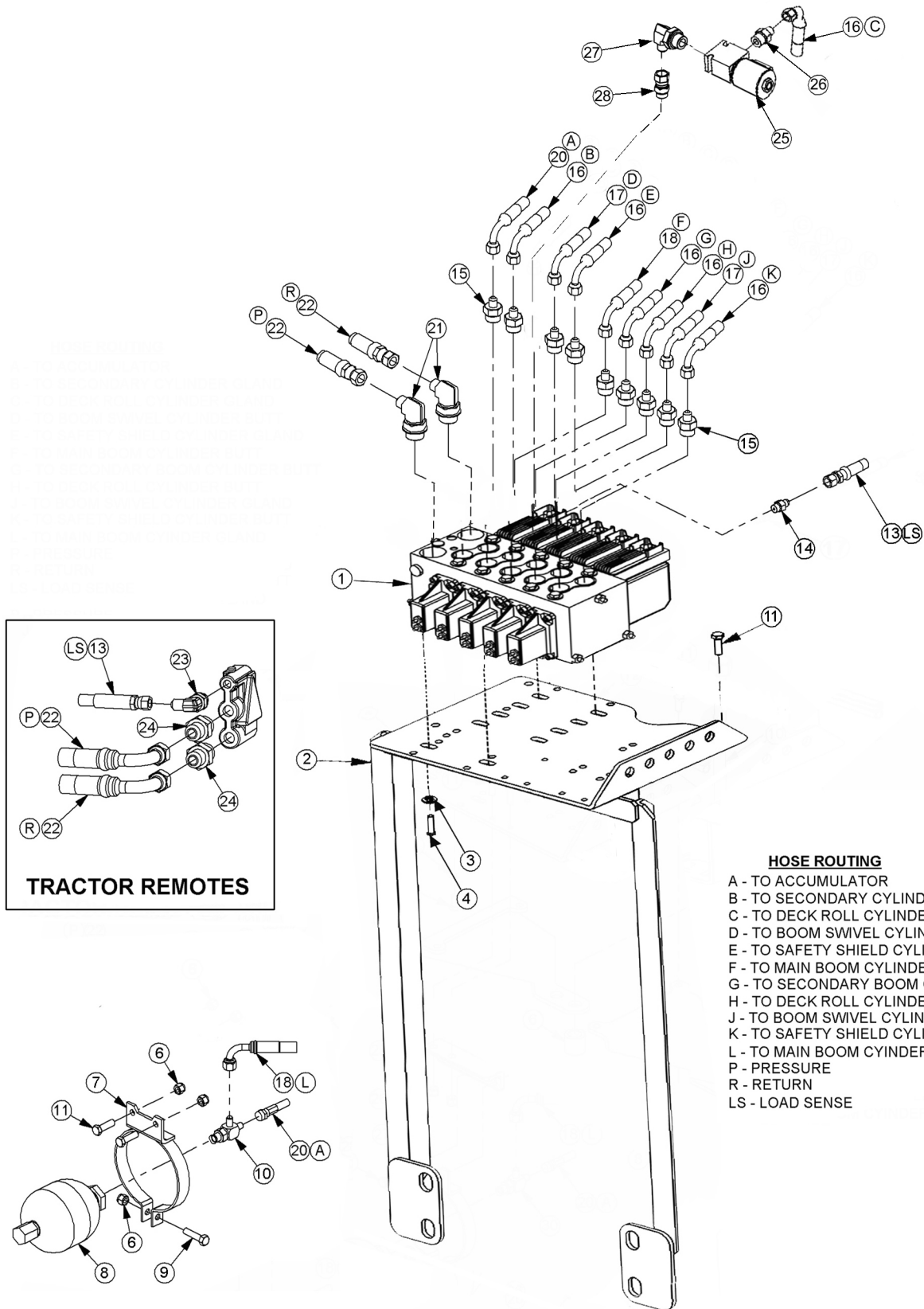



## ELECTRONIC PROPORTIONAL LIFT VALVE MOUNT

Continued...

| ITEM | PART NO. | QTY. | DESCRIPTION                    |
|------|----------|------|--------------------------------|
| 1    | 06502097 | 1    | ELECTRONIC LIFT VALVE          |
| 2    | 06340063 | 1    | PLATE, VALVE, JD6110-30M/R T4F |
| 3    | 21987    | 4    | LOCKWASHER, 5/16"              |
| 4    | 21579    | 4    | CAPSCREW, 5/16" X 3/4", NC     |
| 6    | 21627    | 5    | NYLOCK NUT, 3/8", NC           |
| 7    | 23888    | 1    | BRKT, ACCUMULATOR              |
| 8    | 24300    | 1    | ACCUMULATOR                    |
| 9    | 21632    | 1    | CAPSCREW, 3/8" X 1-1/2", NC    |
| 10   | 06503029 | 1    | TEE, RUN                       |
| 11   | 21631    | 4    | CAPSCREW, 3/8" X 1-1/4", NC    |
| 13   | 06500400 | 1    | HOSE, 1/4" X 34"               |
| 14   | 33392    | 1    | ADAPTER                        |
| 15   | 32807    | 9    | ADAPTER                        |
| 16   | 06500854 | 6    | HOSE, 1/4" X 274"              |
| 17   | 06500697 | 2    | HOSE, 1/4" X 210"              |
| 18   | 06500855 | 2    | HOSE, 1/4" X 294"              |
| 20   | 33744    | 1    | HOSE, 1/4" X 34"               |
| 21   | 33294    | 2    | ELBOW                          |
| 22   | 34612    | 2    | HOSE, 1/2" X 34"               |
| 23   | 06503013 | 1    | ELBOW, 14MM MOR X 5/16" MJ     |
| 24   | 33463    | 2    | ADAPTER, 22MM MOR X 1/2" MJ    |
| 25   | 06510050 | 1    | TRAVEL LOCK, METRIPACK COIL    |
| 26   | 33271    | 1    | ADAPTER, 1/2" MOR X 3/8" MJ    |
| 27   | 33382    | 1    | ELBOW, 1/2" MB X 1/2" MJ       |
| 28   | 06503041 | 1    | ADAPTER, 5/8" ORB X 1/2" FJX   |

# JOYSTICK AND SWITCHBOX MOUNT

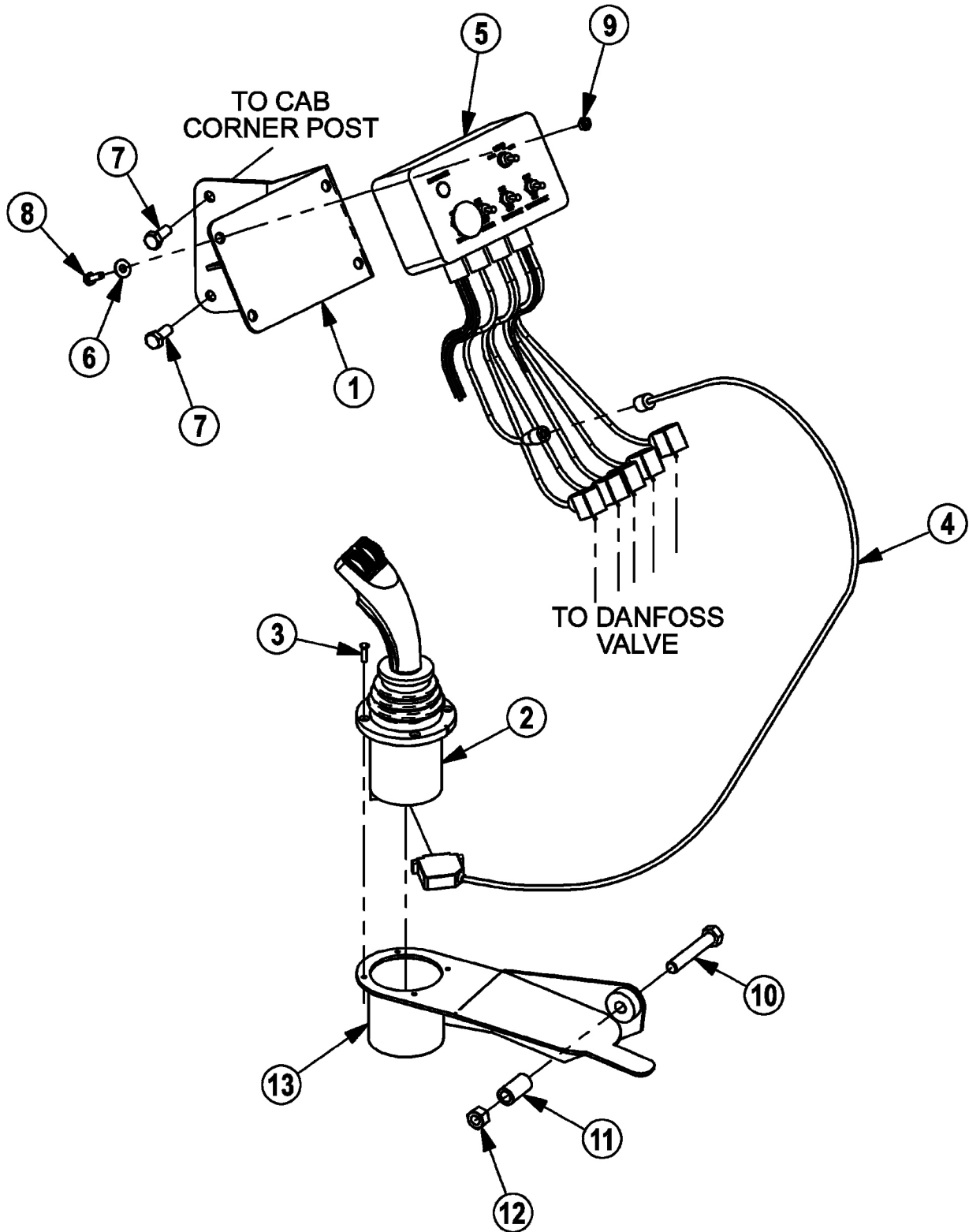

## JOYSTICK AND SWITCHBOX MOUNT

Continued...

| ITEM | PART NO. | QTY. | DESCRIPTION                      |
|------|----------|------|----------------------------------|
| 1    | 33355    | 1    | MNT,BRKT,SWITCH BOX              |
| 2    | 33691    | 1    | JOYST,4AXIS,RH,DF                |
| 3    | 32829    | 4    | SCREW,MACHINE,10-32 X 3/4",FLTHD |
| 4    | 33693    | 1    | CBL,EXT,4FT,JOYST                |
| 5    | 06510196 | 1    | SWITCH BOX                       |
| 6    | 22014    | 4    | FLATWASHER,1/4"                  |
| 7    | 27513    | 2    | CAPSCREW,10MMX25MM(1.5 PITCH)    |
| 8    | 21529    | 4    | CAPSCREW,1/4" X 3/4",NC          |
| 9    | 21527    | 4    | NYLOCK NUT,1/4",NC               |
| 10   | 21737    | 1    | CAPSCREW,1/2" X 3",NC            |
| 11   | 33359    | 1    | TUBE,SPACER                      |
| 12   | 21727    | 1    | NYLOCK NUT,1/2",NC               |
| 13   | 33356    | 1    | ARMREST,JOYSTICK                 |

**BOOM MOUNT KIT**

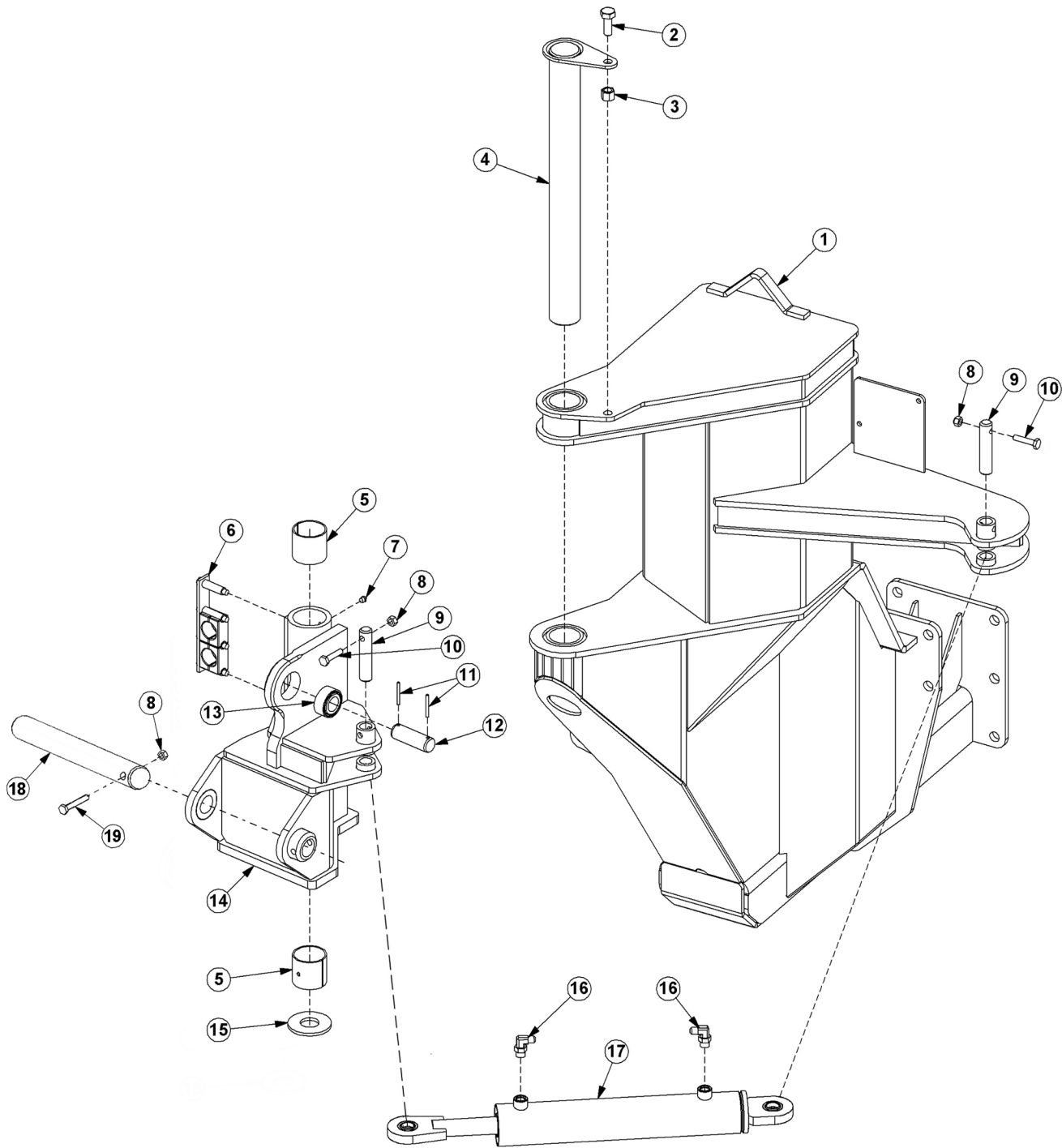

## BOOM MOUNT KIT

Continued...

| ITEM | PART NO. | QTY. | DESCRIPTION                           |
|------|----------|------|---------------------------------------|
| 1    | -----    | -    | MAINFRAME *REFER TO TRACTOR MOUNT KIT |
| 2    | 21782    | 1    | CAPSCREW,5/8" X 1-3/4",NC             |
| 3    | 21777    | 1    | NYLOCK NUT,5/8",NC                    |
| 4    | 32381    | 1    | PIN,CAPPED                            |
| 5    | 32322    | 2    | BUSHING                               |
| 6    | 06505186 | 1    | CLAMP KIT                             |
| 7    | 6T3211   | 2    | GREASE ZERK,1/8"NPT                   |
| 8    | 21677    | 3    | NYLOCK NUT,7/16",NC                   |
| 9    | 32380    | 2    | PIN,1"                                |
| 10   | 21683    | 2    | CAPSCREW,7/16" X 2",NC                |
| 11   | TB1023   | 2    | ROLL PIN                              |
| 12   | 06420100 | 1    | PIN,1-1/4"                            |
| 13   | -----    | -    | SPHERICAL BEARING *NOT FOR SALE       |
| 14   | 06700221 | 1    | SWIVEL ASSEMBLY                       |
| ---  | 06310190 | 1    | SWIVEL WELDMENT                       |
| 15   | 06520250 | 1    | BEARING,WASHER                        |
| 16   | 32810    | 2    | ADAPTER,ELBOW                         |
| 17   | 06501029 | 1    | CYLINDER,3" X 13.88"                  |
| 18   | 06420022 | 1    | PIN, 1/5" X 12"                       |
| 19   | 21688    | 1    | CAPSCREW, 7/16" X 3-1/4"              |

# BOOMREST - OPEN STOW

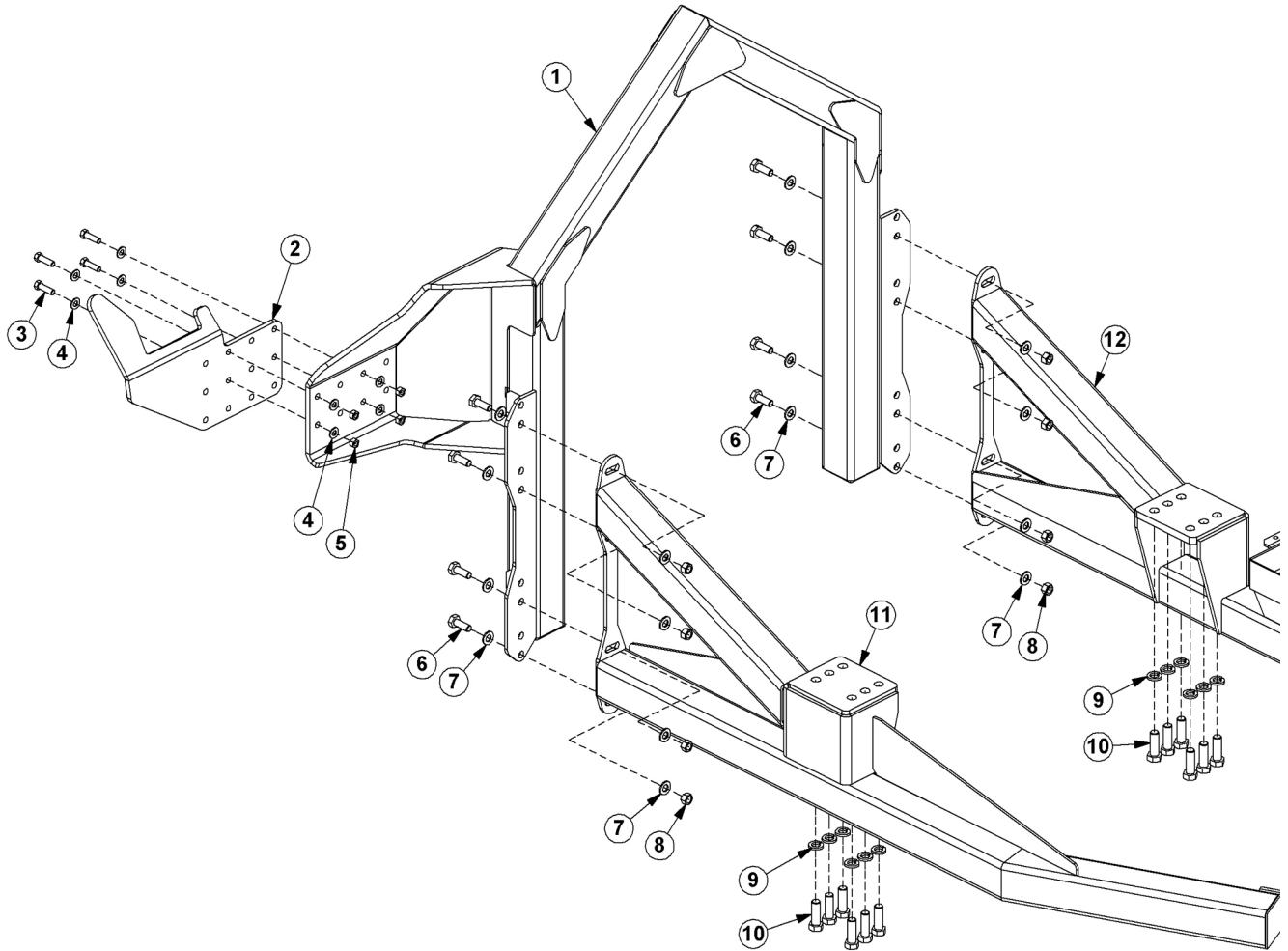

## BOOMREST - OPEN STOW

Continued...

| ITEM | PART NO. | QTY. | DESCRIPTION               |
|------|----------|------|---------------------------|
| 1    | 06310157 | 1    | BOOMREST,OS, T4           |
| 2    | 06310186 | 1    | SADDLE                    |
| 3    | 21733    | 4    | CAPSCREW,1/2" X 2",NC     |
| 4    | 06533004 | 8    | FLATWASHER,1/2",SAE       |
| 5    | 21725    | 4    | HEX NUT,1/2",NC           |
| 6    | 21782    | 8    | CAPSCREW,5/8" X 1-3/4",NC |
| 7    | 33764    | 16   | FLATWASHER,5/8",SAE       |
| 8    | 21775    | 8    | HEX NUT,5/8",NC           |
| 9    | 24881    | 12   | LOCKWASHER,20MM           |
| 10   | 27281    | 12   | CAPSCREW,20MM X 60MM,2.5P |
| 11   | 06300384 | 1    | AXLE BRACE,RH             |
| 12   | 06300386 | 1    | AXLE BRACE,LH             |

# FRONT AXLE STABILIZER OPTION

## HOSE ROUTING KEY

- A- FROM 1B PORT ON LIFT VALVE TO STABILIZER CYLINDER GLAND
- B- FROM 1B PORT ON LIFT VALVE TO MAIN BOOM CYLINDER BUTT
- C- FROM 1A PORT ON LIFT VALVE TO ACCUMULATOR
- D- FROM ACCUMULATOR TO MAIN BOOM CYLINDER GLAND
- E- FROM STABILIZER CYLINDER BUTT TO ACCUMULATOR

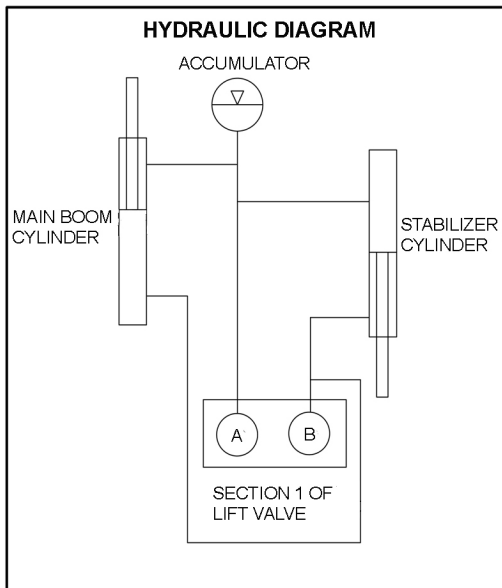
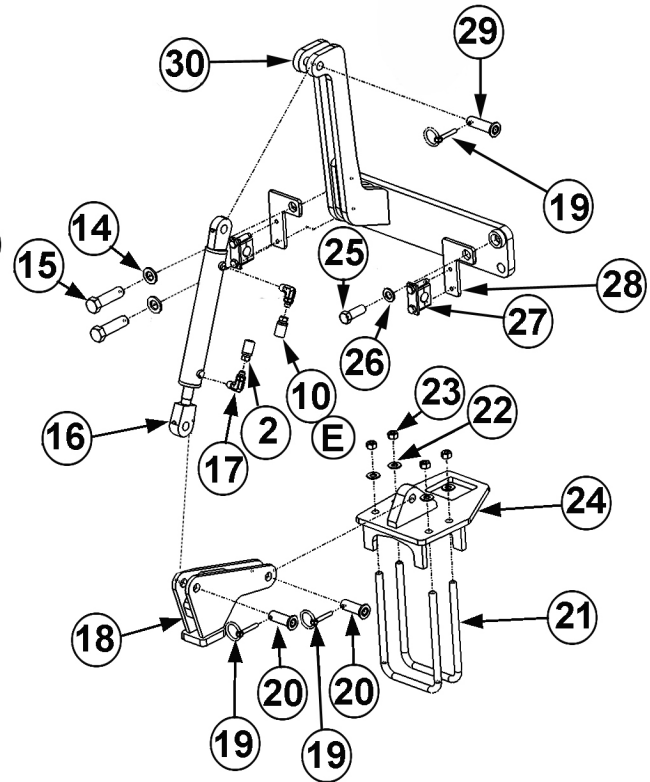
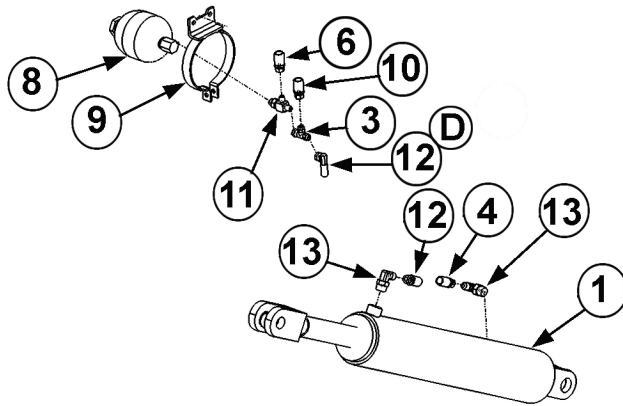
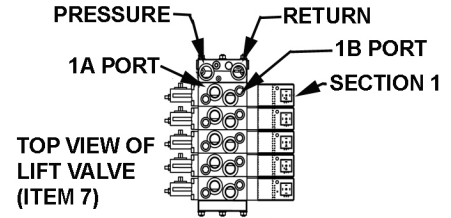
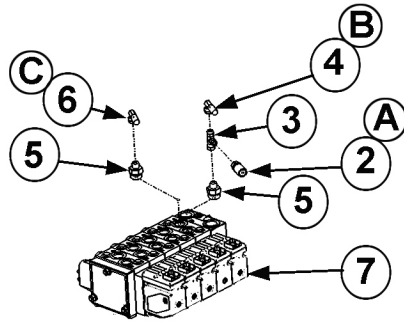

LOCATE HOLE IN ITEM 24 AROUND AXLE STOP ON RIGHT FRONT AXLE.  
 USE ITEMS 21, 22, & 23 TO CLAMP ITEM 24 TO AXLE.  
 AFTER INSTALLATION, ARTICULATE FRONT AXLE FROM STOP TO STOP AND EXTEND AND RETRACT CYLINDER FULLY TO ENSURE A PROPER FIT.



## FRONT AXLE STABILIZER OPTION

Continued...

| ITEM | PART NO. | QTY. | DESCRIPTION                                |
|------|----------|------|--------------------------------------------|
| 1    | -----    | -    | BOOM CYLINDER *REFER TO COMMON SECTION     |
| 2    | 06500149 | 1    | HOSE,1/4" X 220"                           |
| 3    | 06503048 | 2    | RUN TEE,3/8" MJ X 3/8" FJX X 3/8" MJ       |
| 4    | -----    | -    | HOSE *REFER TO LIFT VALVE PAGE             |
| 5    | -----    | -    | ADAPTER *REFER TO LIFT VALVE PAGE          |
| 6    | -----    | -    | HOSE *REFER TO LIFT VALVE PAGE             |
| 7    | -----    | -    | LIFT VALVE *REFER TO LIFT VALVE PAGE       |
| 8    | -----    | -    | ACCUMULATOR *REFER TO LIFT VALVE PAGE      |
| 9    | -----    | -    | ACCUMULATOR BRKT *REFER TO LIFT VALVE PAGE |
| 10   | 06500149 | 1    | HOSE,1/4" X 220"                           |
| 11   | -----    | -    | RUN TEE *REFER TO LIFT VALVE PAGE          |
| 12   | -----    | -    | HOSE *REFER TO LIFT VALVE PAGE             |
| 13   | -----    | -    | ELBOW *REFER TO LIFT VALVE PAGE            |
| 14   | 33880    | 2    | FLATWASHER,3/4",SAE                        |
| 15   | 32703    | 2    | CAPSCREW,20MM X 100MM,2.5P                 |
| 16   | 33785    | 1    | CYLINDER,1-1/2" X 8"                       |
| 17   | 06503055 | 2    | ELBOW,1/4" MOR X 3/8" MJ                   |
| 18   | 06310132 | 1    | LINK,PIVOT,STABILIZER                      |
| 19   | RD1032   | 3    | LYNCH PIN                                  |
| 20   | 33984    | 2    | PIN,3/4" X 2-7/16"                         |
| 21   | 06420140 | 2    | U-BOLT                                     |
| 22   | 06533004 | 4    | FLATWASHER,1/2",SAE                        |
| 23   | 21700    | 4    | HEX NUT,1/2",UNC                           |
| 24   | 06310176 | 1    | MOUNT,AXLE                                 |
| 25   | -----    | -    | CAPSCREW *REFER TO LIFT VALVE PAGE         |
| 26   | -----    | -    | FLATWASHER *REFER TO LIFT VALVE PAGE       |
| 27   | -----    | -    | CLAMP KIT *REFER TO LIFT VALVE PAGE        |
| 28   | -----    | -    | BRACKET *REFER TO LIFT VALVE PAGE          |
| 29   | 34799    | 1    | PIN,3/4" X 2-15/16"                        |
| 30   | 06310177 | 1    | STABILIZER,AXLE,CYL MNT                    |

## POLYCARBONATE SAFETY WINDOW

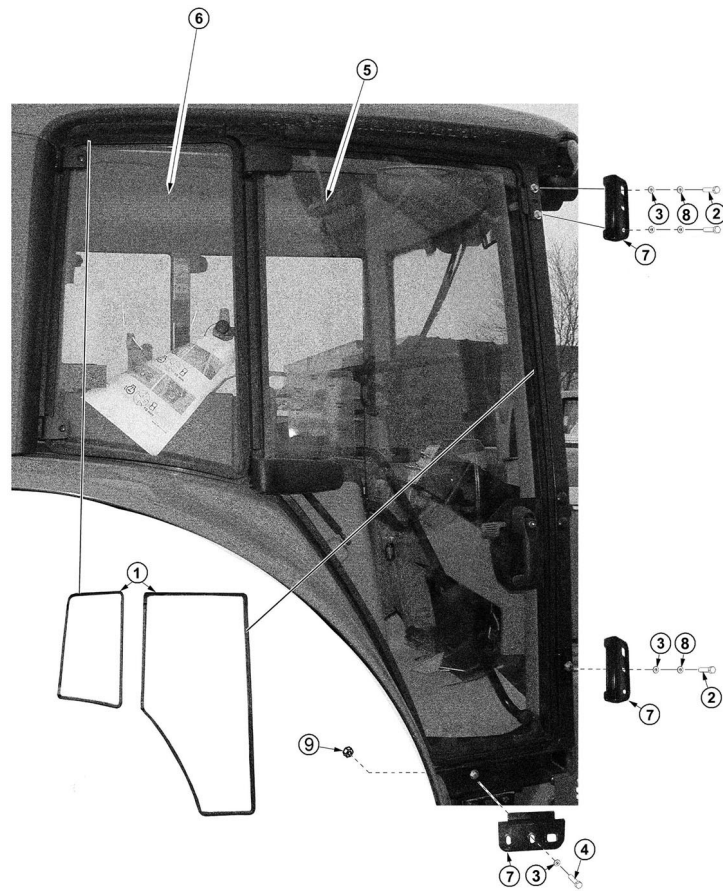

| ITEM | PART NO. | QTY. | DESCRIPTION                         |
|------|----------|------|-------------------------------------|
| 1    | 31965    | 22   | TRIM SEAL,3/8" CLIP X 3/4"OD (FEET) |
| 2    | 27508    | 3    | CAPSCREW,8MM X 20MM,1.25P           |
| 3    | 22015    | 4    | FLATWASHER,5/16"                    |
| 4    | 21581    | 1    | CAPSCREW,5/16" X 1-1/4",NC          |
| 5    | 06490005 | 1    | POLYCARB,FRMD,DOOR,RH               |
| 6    | 06490027 | 1    | POLYCARB,FRMD,REAR,RH               |
| 7    | 06520040 | 3    | BRKT,JD,POLY,RETAIN                 |
| 8    | 6T2619   | 3    | LOCKWASHER,8MM                      |
| 9    | 21577    | 1    | NYLOCK NUT,5/16",NC                 |

# WHEEL SPACER

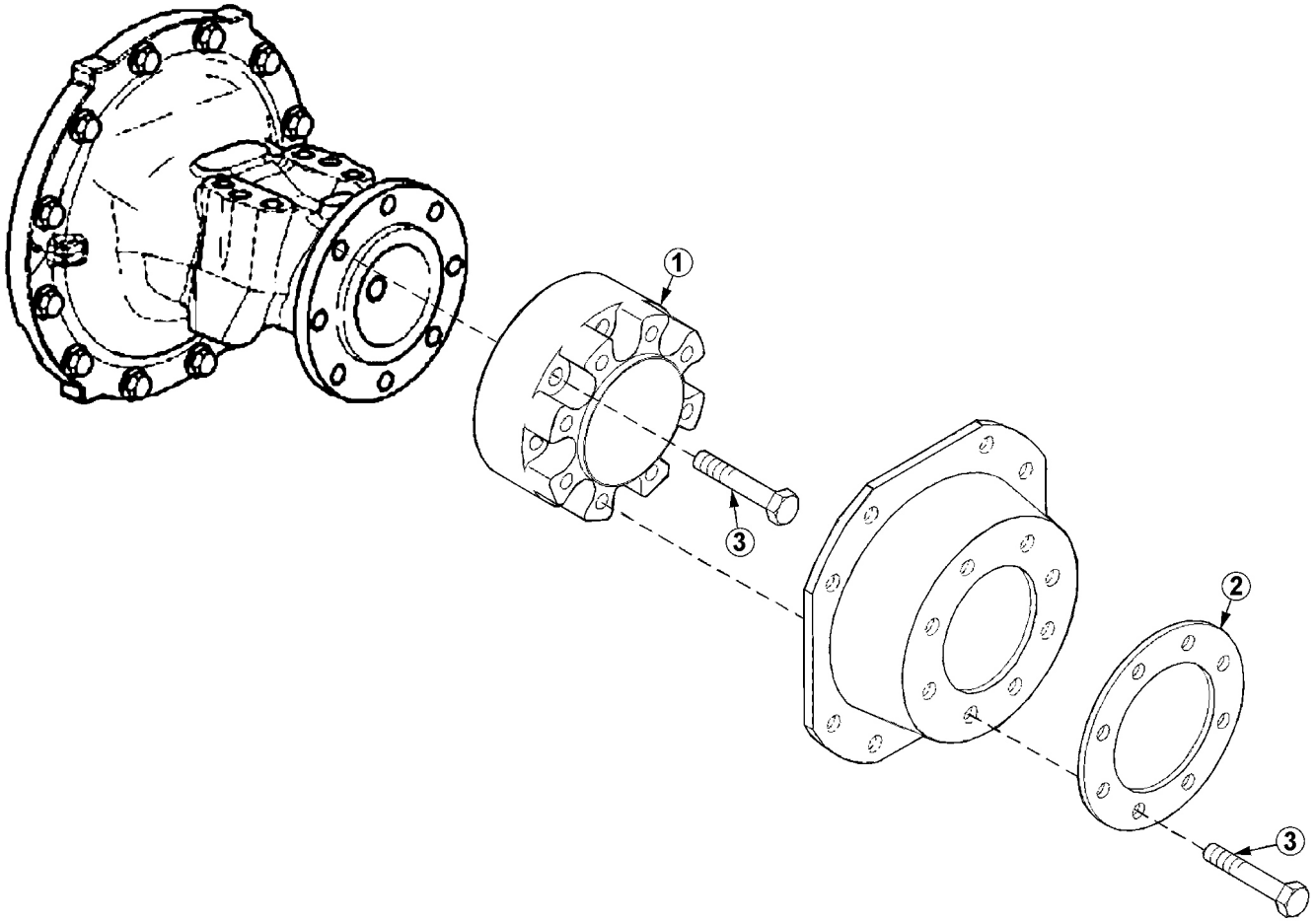

| ITEM | PART NO. | QTY. | DESCRIPTION             |
|------|----------|------|-------------------------|
| 1    | AL156779 | 1    | SPCR, WHL, JD, 1.732    |
| 2    | 06400919 | 1    | RING, SPACER, WHEEL, JD |
| 3    | 6T2548   | 16   | CAPSCREW, 20MM X 60MM   |

## WHEEL WEIGHT

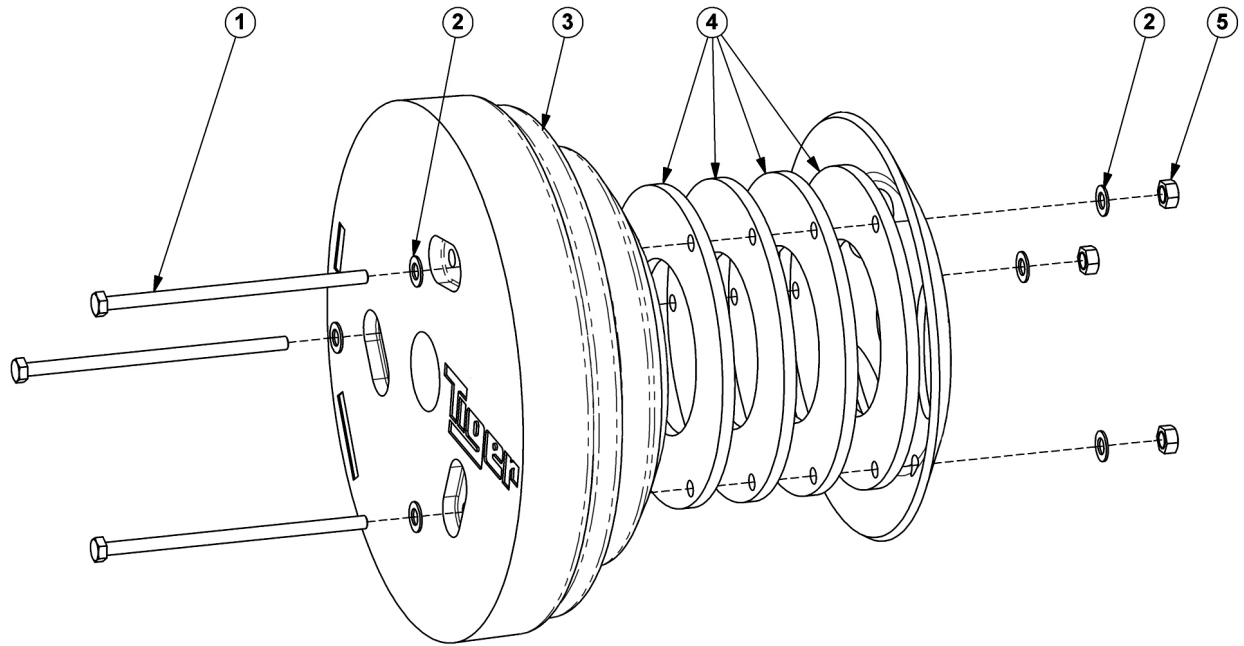

| ITEM | PART NO. | QTY. | DESCRIPTION                   |
|------|----------|------|-------------------------------|
| 1    | 06530213 | 3    | CAPSCREW, 7/8" X 16", NC, GR8 |
| 2    | 06533000 | 6    | FLATWASHER, 7/8", GR8         |
| 3    | 32517    | 1    | WHEEL WEIGHT, 1700#           |
| 4    | 06400410 | 4    | SPACER                        |
| 5    | 06531000 | 3    | HEX NUT, 7/8", NC, GR8        |

**PARTS SECTION**

# NOTES

## PART NAME INDEX

|                                                 |    |
|-------------------------------------------------|----|
| PARTS ORDERING GUIDE.....                       | 5  |
| BOOM ASSY - BENGAL 18 T4.....                   | 6  |
| BOOM ASSY BENGAL STANDARD 22 T4.....            | 8  |
| BOOM ASSY HYD BENGAL 22 T4.....                 | 10 |
| BOOM ASSY BENGAL EXT 24 T4.....                 | 12 |
| BOOM ASSY HYD BENGAL 24 T4.....                 | 14 |
| BOOMREST - OPEN STOW.....                       | 16 |
| 50IN ROTARY MOWER ASSEMBLY.....                 | 18 |
| 50IN ROTARY KNIVES AND DISH.....                | 20 |
| 50IN ROTARY BLADE BAR AND KNIVES.....           | 21 |
| 60IN ROTARY MOWER ASSEMBLY.....                 | 22 |
| 60IN ROTARY KNIVES AND DISH.....                | 24 |
| 60IN ROTARY BLADE BAR AND KNIVES.....           | 25 |
| ROTARY MOWER SPINDLE ASSEMBLY.....              | 26 |
| BOOM ROTARY PIVOT ASSEMBLY.....                 | 28 |
| 50IN FLAIL DRIVE ASSEMBLY.....                  | 30 |
| 50IN FLAIL MOWER ASSEMBLY.....                  | 32 |
| 50IN FLAIL MOWER ASSY, PASS-THROUGH KNIVES..... | 34 |
| 63IN FLAIL DRIVE ASSEMBLY.....                  | 36 |
| 63IN FLAIL MOWER ASSEMBLY.....                  | 38 |
| BOOM FLAIL PIVOT ASSEMBLY.....                  | 40 |
| 3IN X 13-7/8 IN WELDED CYLINDER BREAKDOWN.....  | 42 |
| 3IN X 18IN WELDED CYLINDER BREAKDOWN.....       | 43 |
| 3-1/2IN X 20IN WELDED CYLINDER BREAKDOWN.....   | 44 |
| 4IN X 20IN WELDED CYLINDER BREAKDOWN.....       | 45 |
| 5IN X 20IN WELDED CYLINDER BREAKDOWN.....       | 46 |
| NOTES.....                                      | 47 |
| 5 SPOOL ELECTRONIC VALVE - OPEN STOW,3PS.....   | 48 |
| 5 SPOOL ELECTRONIC VALVE - SIDE STOW.....       | 50 |
| FRONT HYDRAULIC PUMP.....                       | 52 |
| 50IN AND 60IN ROTARY MOTOR BREAKDOWN.....       | 54 |
| FLAIL MOTOR BREAKDOWN.....                      | 56 |
| RESERVOIR TANK FILTER ASSEMBLY.....             | 58 |
| PUMP AND GRILL GUARD OPTIONS.....               | 59 |
| BOOM TRAVEL LOCK.....                           | 60 |
| MANUAL LIFT VALVE SWITCH BOX.....               | 61 |
| MANUAL LIFT VALVE SCHEMATIC.....                | 62 |
| ELECTRONIC LIFT VALVE SWITCH BOX.....           | 63 |
| ELECTRONIC LIFT VALVE SCHEMATIC.....            | 64 |
| SOLENOID SWITCH BOX AND WIRING.....             | 65 |

COMMON BENGAL T4

## PART NAME INDEX

|                                       |    |
|---------------------------------------|----|
| BRAKE VALVE ASSEMBLY.....             | 66 |
| BRAKE VALVE HYDRAULIC SCHEMATIC.....  | 67 |
| ELECTRICAL TROUBLESHOOTING GUIDE..... | 68 |
| HYDRAULIC TROUBLESHOOTING GUIDE.....  | 69 |
| TROUBLESHOOTING.....                  | 70 |
| TROUBLESHOOTING - CONTINUED.....      | 71 |
| WHEEL WEIGHT - BENGAL 18.....         | 72 |



## PARTS ORDERING GUIDE

The following instructions are offered to help eliminate needless delay and error in processing purchase orders for the equipment in this manual.

1. The Parts Section is prepared in logical sequence and grouping of parts that belong to the basic machine featured in this manual. Part Numbers and Descriptions are given to help locate the parts and quantities required.
2. The Purchase Order must indicate the **Name and Address** of the person or organization ordering the parts, **who should be charged**, and if possible, the **serial number of the machine** for which the parts are being ordered.
3. The purchase order must clearly list the **quantity of each part**, the complete and correct **part number**, and the basic **name of the part**.
4. The manufacturer reserves the right to substitute parts where applicable.
5. Some parts may be unlisted items which are special production items not normally stocked and are subject to special handling. Request a quotation for such parts before sending a purchase order.
6. The manufacturer reserves the right to change prices without prior notice.

NOTE: When ordering replacement decals, refer to the part numbers and descriptions listed in the safety section in the front of this manual.



For maximum safety and to guarantee optimum product reliability, always use genuine **Tiger** replacement parts. The use of inferior replacement parts may cause premature or catastrophic failure which could result in serious injury or death.

Direct any questions regarding parts to:

**Tiger Corporation**  
3301 N. Louise Ave.  
Sioux Falls, SD 57107  
1-800-843-6849  
1-605-336-7900

# BOOM ASSY - BENGAL 18 T4

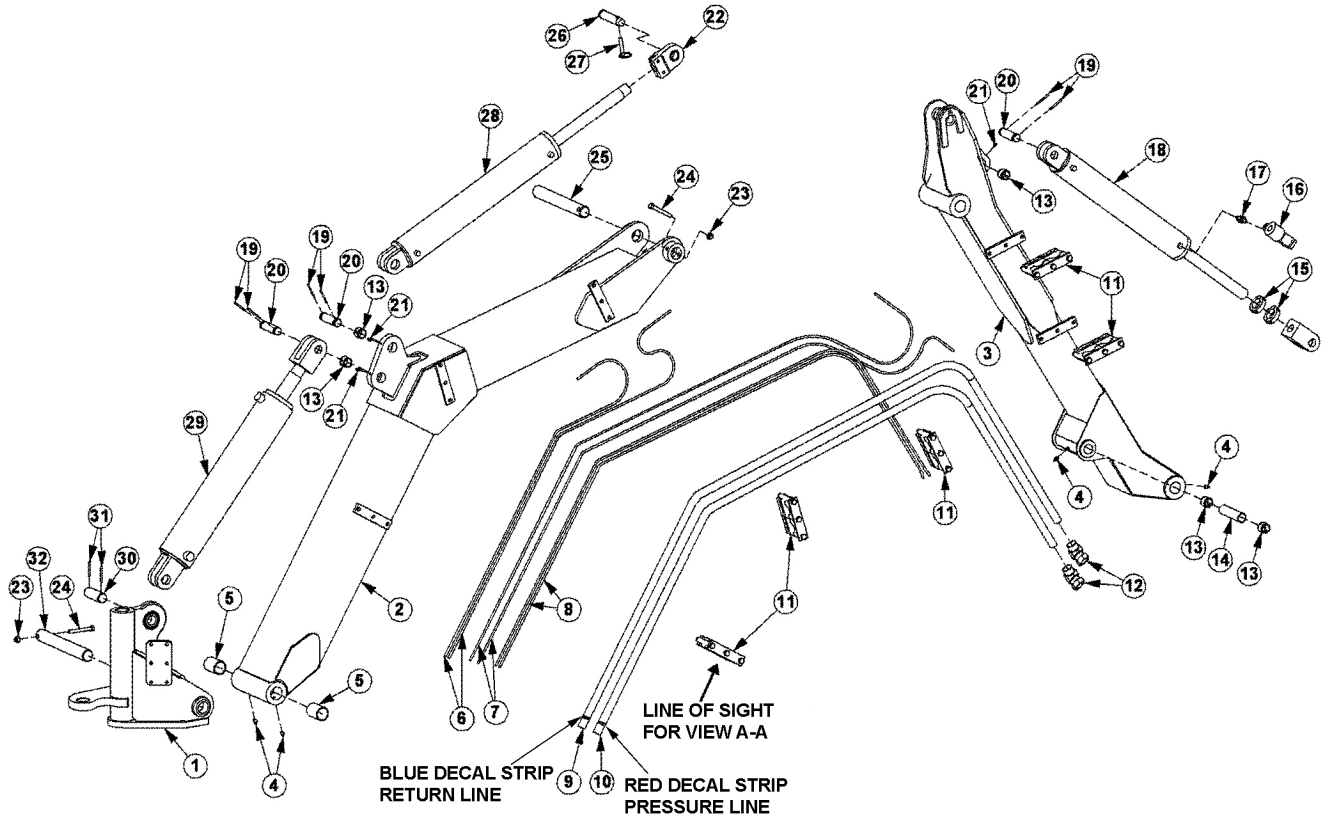

**NOTES:**

1. IMPORTANT: ALIGN GREASE HOLE OR GAP IN BEARING (ITEMS 5 & 13) WITH GREASE ZERK IN BOOM. MAINTAIN ALIGNMENT DURING BEARING INSTALLATION.
2. GREASE HINGE PIN ZERKS (ITEM 4) ON BOOM AFTER ASSEMBLY, ONCE UNDER LOAD WITH BOOM ELEVATED AND AGAIN AT REST WITH BOOM SUPPORTED.
3. ONLY ONE SET COLLAR (ITEM 15) NEEDED FOR ROTARY MOWERS.

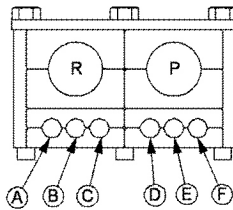

**KEY**

- A - SECONDARY BUTT
- B - SECONDARY GLAND
- C - DECK ROLL BUTT
- D - DECK ROLL GLAND
- E - SHIELD BUTT
- F - SHIELD GLAND
- R - RETURN
- P - PRESSURE

## BOOM ASSY - BENGAL 18 T4

Continued...

| ITEM | PART NO. | QTY. | DESCRIPTION                     |
|------|----------|------|---------------------------------|
| 1    | ----     | -    | REAR STOW SWIVEL ASSY           |
| 2    | 06700167 | -    | MAIN BOOM ASSY                  |
| ---  | 06310111 | 1    | MAIN BOOM WELDMENT              |
| 3    | 06700168 | -    | SECONDARY BOOM ASSY             |
| ---- | 06310112 | 1    | SECONDARY BOOM WELDMENT         |
| 4    | 6T3211   | 4    | GREASE ZERK,1/8"                |
| 5    | 32321    | 2    | BEARING, DX, 1-1/2" X 2"        |
| 6    | 06500499 | 2    | HOSE,1/4" X 50"                 |
| 7    | 06500500 | 2    | HOSE,1/4" X 108"                |
| 8    | 06500502 | 2    | HOSE,1/4" X 100"                |
| 9    | 06500713 | 1    | HOSE,1" X 163"                  |
| 10   | 06500714 | 1    | HOSE,1" X 162"                  |
| 11   | 06505116 | 2    | CLAMP KIT                       |
| 12   | 24724    | 2    | SWIVEL,1MJ X 1FJX45             |
| 13   | TB3010   | 3    | BUSHING                         |
| 14   | TB1035   | 1    | BUSHING,SPACER                  |
| 15   | 35312    | 1    | SET COLLAR                      |
| 16   | 06510050 | 1    | TRAVEL LOCK,METRIPACK COIL      |
| 17   | 31329    | 1    | ADAPTER,1/2ORB X 1/2ORB ADJ     |
| 18   | 06501023 | 1    | DECK ROLL CYLINDER,3" X 18"     |
| 19   | 06537021 | 6    | ROLL PIN,5MM                    |
| 20   | TB1033   | 4    | PIN,1"                          |
| 21   | 6T3207   | 4    | GREASE ZERK,1/4"                |
| 22   | TB3033   | 1    | CLEVIS WITH SPHERICAL BEARING   |
| 23   | 21677    | 2    | NYLOCK NUT,7/16",NC             |
| 24   | 21688    | 2    | CAPSCREW,7/16" X 3-1/4",NC      |
| 25   | TB1025   | 1    | PIN,1-1/2"                      |
| 26   | TB1036   | 1    | PIN,1"                          |
| 27   | TF1143   | 1    | PIN,LYNCH                       |
| 28   | 06501024 | 1    | SECONDARY CYLINDER,3-1/2" X 20" |
| 29   | 06501022 | 1    | MAIN CYLINDER,4" X 20"          |
| 30   | 06420100 | 1    | PIN,1-1/4"                      |
| 31   | TB1023   | 2    | ROLL PIN,7/32"                  |
| 32   | TB3013C  | 1    | PIN,1-1/2"                      |

COMMON BENGAL T4

# BOOM ASSY BENGAL STANDARD 22 T4

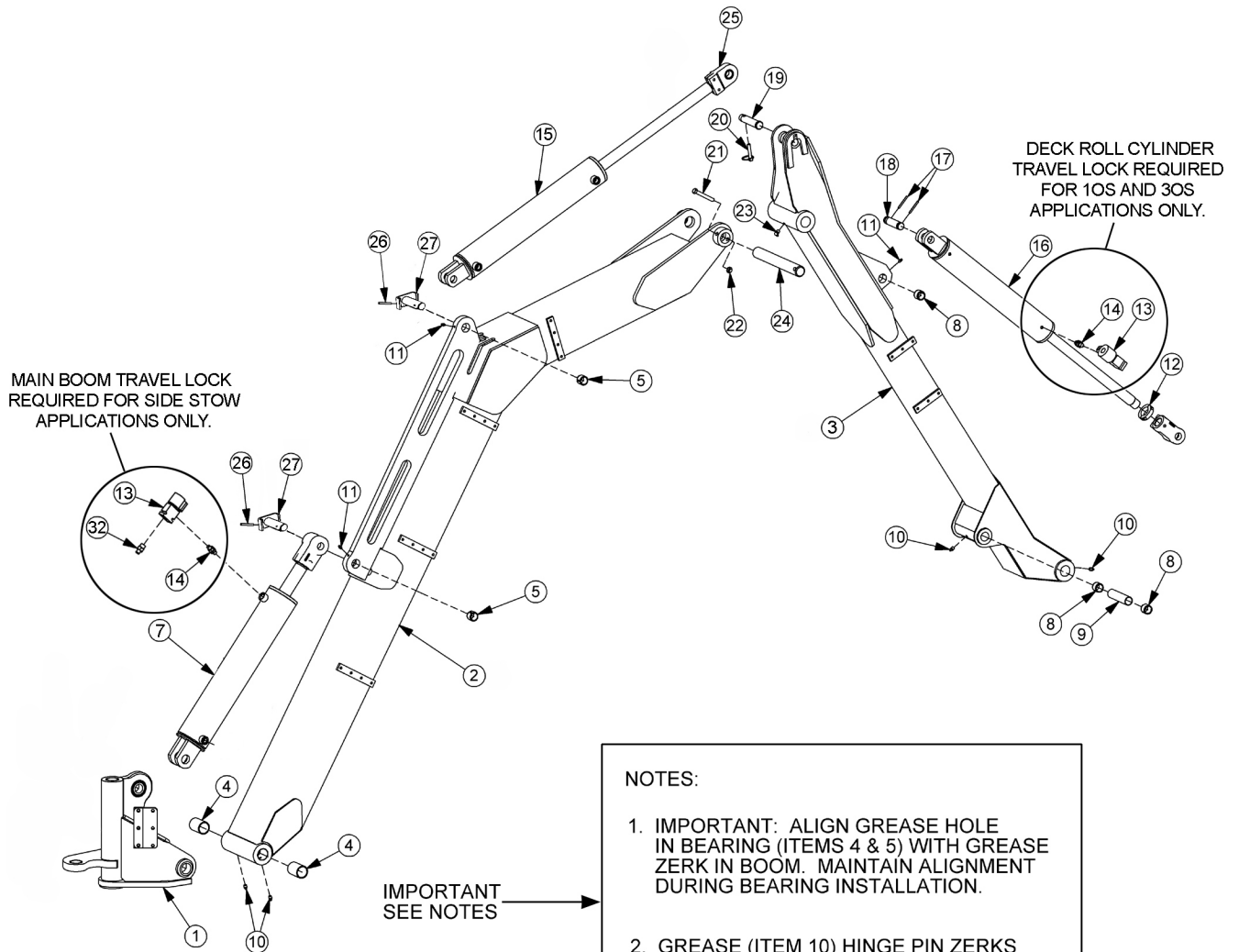

**NOTES:**

1. IMPORTANT: ALIGN GREASE HOLE IN BEARING (ITEMS 4 & 5) WITH GREASE ZERK IN BOOM. MAINTAIN ALIGNMENT DURING BEARING INSTALLATION.
2. GREASE (ITEM 10) HINGE PIN ZERKS ON BOOM AFTER ASSEMBLY, ONCE UNDER LOAD WITH BOOM ELEVATED AND AGAIN AT REST WITH BOOM SUPPORTED.

## BOOM ASSY BENGAL STANDARD 22 T4

Continued...

| ITEM | PART NO. | QTY. | DESCRIPTION                             |
|------|----------|------|-----------------------------------------|
| 1    | -----    | -    | SWIVEL ASSY *REFER TO TRACTOR MOUNT KIT |
| 2    | 06700189 | 1    | MAIN BOOM, T4                           |
| 3    | 24517    | 1    | SECONDARY BOOM ARM ASSY                 |
| 4    | 32321    | 2    | BEARING, DX, 1-1/2" X 2"                |
| 5    | TB1044   | 2    | BUSHING, 1-1/4"ID                       |
| 7    | 06501020 | 1    | CYLINDER, 5" X 20"                      |
| 8    | TB3010   | 3    | BUSHING, 1"ID                           |
| 9    | TB1035   | 1    | BUSHING,SPACER                          |
| 10   | 6T3211   | 4    | GREASE ZERK,1/8"                        |
| 11   | 6T3207   | 3    | GREASE ZERK,1/4                         |
| 12   | 35312    | 1    | SET COLLAR                              |
| 13   | 06510050 | 1    | TRAVEL LOCK,METRIPACK COIL              |
| 14   | 31329    | 1    | ADAPTER,1/2ORB X 1/2ORB ADJ             |
| 15   | 06501022 | 1    | CYLINDER, 4" X 20"                      |
| 16   | 06501023 | 1    | CYLINDER,3" X 18"                       |
| 17   | 06537021 | 6    | ROLL PIN,5MM                            |
| 18   | TB1033   | 1    | PIN,1" X 4"                             |
| 19   | TB1036   | 1    | PIN,1" X 4-11/16"                       |
| 20   | TF1143   | 1    | PIN,LYNCH                               |
| 21   | 21688    | 2    | CAPSCREW,7/16" X 3-1/4",NC              |
| 22   | 21677    | 2    | NYLOCK NUT,7/16",NC                     |
| 23   | 6T3210   | 1    | GREASE ZERK,1/8" X 90                   |
| 24   | TB1025   | 1    | PIN,1-1/2" X 12"                        |
| 25   | 30172    | 1    | CLEVIS,SPHERICAL                        |
| 26   | 6T3014   | 2    | ROLL PIN, 1/4" X 2"                     |
| 27   | TB1045B  | 2    | PIN, PRIMARY CYLINDER                   |

# BOOM ASSY HYD BENGAL 22 T4

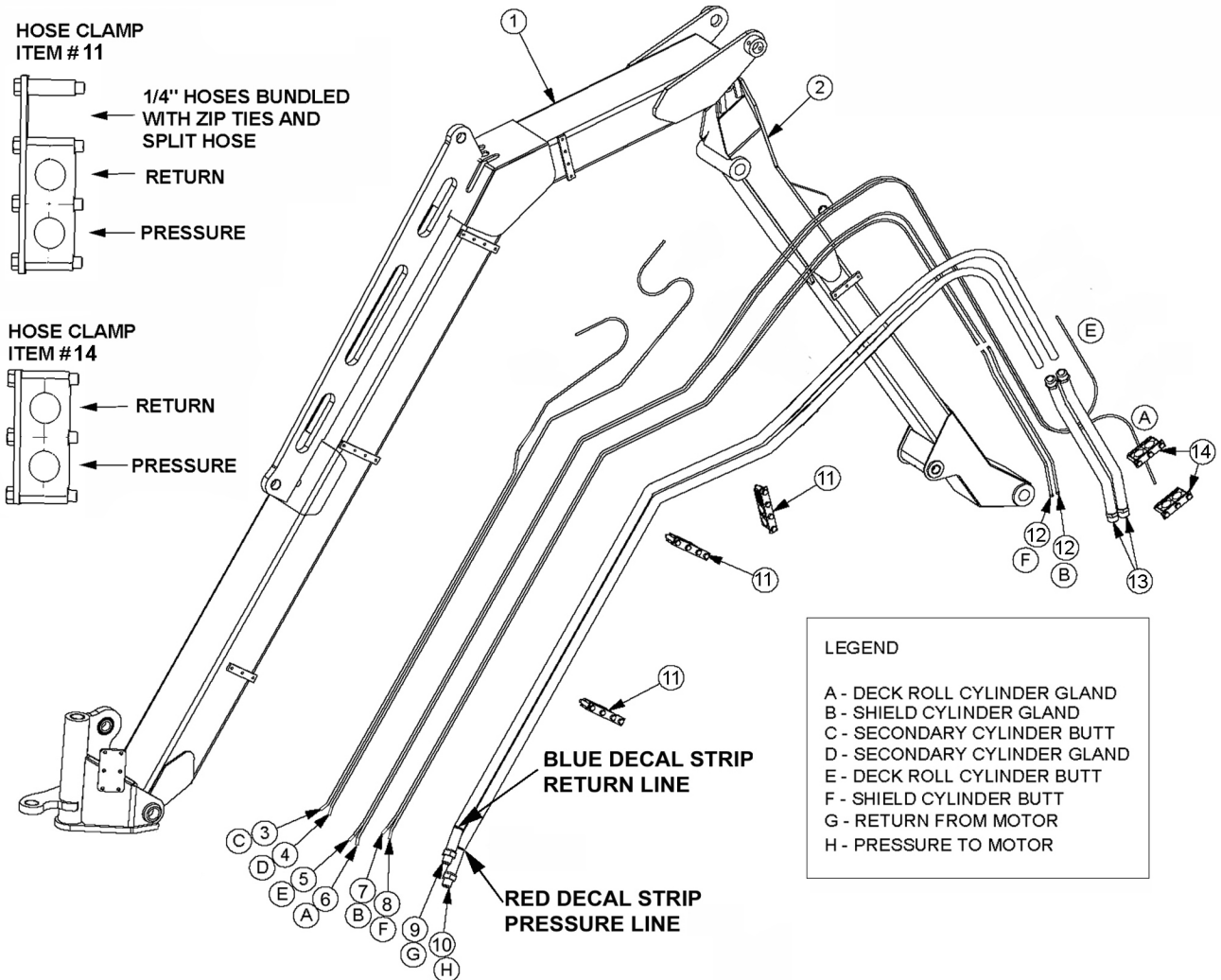

## BOOM ASSY HYD BENGAL 22 T4

Continued...

| ITEM | PART NO. | QTY. | DESCRIPTION                            |
|------|----------|------|----------------------------------------|
| 1    | -----    | -    | MAIN BOOM *REFER TO BOOM ARM ASSY      |
| 2    | -----    | -    | SECONDARY BOOM *REFER TO BOOM ARM ASSY |
| 3    | 06500694 | 1    | HOSE, 1/4" X 83"                       |
| 4    | ---      | 1    | HOSE, 1/4" X 83"                       |
| 5    | 06500695 | 1    | HOSE, 1/4" X 138"                      |
| 6    | ----     | 1    | HOSE, 1/4" X 138"                      |
| 7    | 06500696 | 1    | HOSE, 1/4" X 112"                      |
| 8    | ---      | 1    | HOSE, 1/4" X 112"                      |
| 9    | 34645    | 1    | HOSE, 1" X 182"                        |
| 10   | ---      | 1    | HOSE, 1" X 182"                        |
| 11   | 06505019 | 3    | CLAMP KIT,3 SECTION                    |
| 12   | 34102    | 2    | TUBE,PRFRMD,SEC BOOM                   |
| 13   | 2403306  | 2    | TUBE,PRFRMD,SEC BOOM,HP                |
| 14   | 30111    | 2    | CLAMP KIT,2 SECTION                    |

COMMON BENGAL T4

# BOOM ASSY BENGAL EXT 24 T4

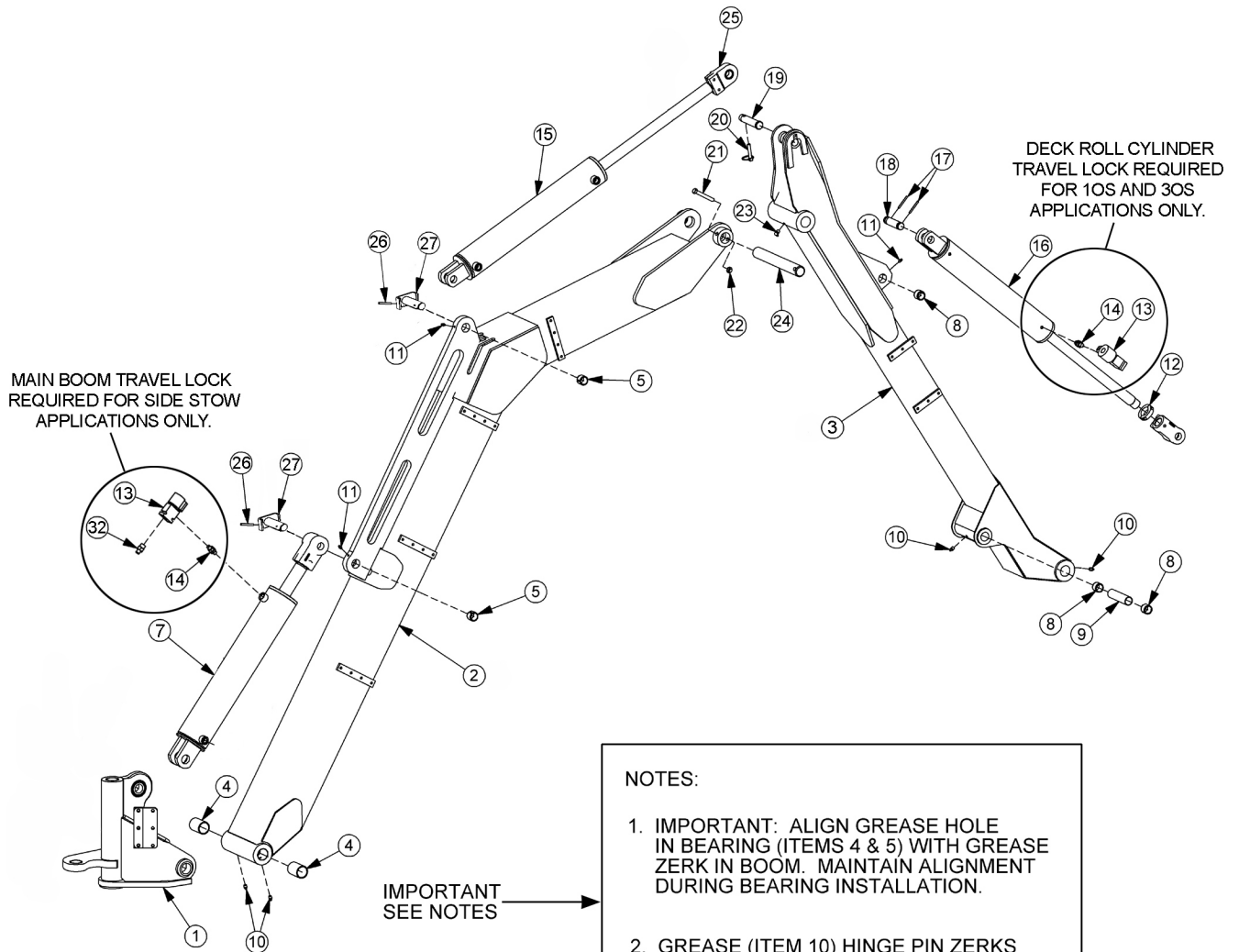



## BOOM ASSY BENGAL EXT 24 T4

Continued...

| ITEM | PART NO. | QTY. | DESCRIPTION                             |
|------|----------|------|-----------------------------------------|
| 1    | -----    | -    | SWIVEL ASSY *REFER TO TRACTOR MOUNT KIT |
| 2    | 06700191 | 1    | MAIN BOOM, EXT, T4                      |
| 3    | 06700094 | 1    | SECONDARY BOOM ARM ASSY, EXT, T4        |
| 4    | 32321    | 2    | BEARING, DX, 1-1/2" X 2"                |
| 5    | TB1044   | 2    | BUSHING, 1-1/4"ID                       |
| 7    | 06501020 | 1    | CYLINDER, 5" X 20"                      |
| 8    | TB3010   | 3    | BUSHING, 1"ID                           |
| 9    | TB1035   | 1    | BUSHING,SPACER                          |
| 10   | 6T3211   | 4    | GREASE ZERK,1/8"                        |
| 11   | 6T3207   | 3    | GREASE ZERK,1/4                         |
| 12   | 35312    | 1    | SET COLLAR                              |
| 13   | 06510050 | 1    | TRAVEL LOCK,METRIPACK COIL              |
| 14   | 31329    | 1    | ADAPTER,1/2ORB X 1/2ORB ADJ             |
| 15   | 06501022 | 1    | CYLINDER, 4" X 20"                      |
| 16   | 06501023 | 1    | CYLINDER,3" X 18"                       |
| 17   | 06537021 | 6    | ROLL PIN,5MM                            |
| 18   | TB1033   | 1    | PIN,1" X 4"                             |
| 19   | TB1036   | 1    | PIN,1" X 4-11/16"                       |
| 20   | TF1143   | 1    | PIN,LYNCH                               |
| 21   | 21688    | 2    | CAPSCREW,7/16" X 3-1/4",NC              |
| 22   | 21677    | 2    | NYLOCK NUT,7/16",NC                     |
| 23   | 6T3210   | 1    | GREASE ZERK,1/8" X 90                   |
| 24   | TB1025   | 1    | PIN,1-1/2" X 12"                        |
| 25   | 30172    | 1    | CLEVIS,SPHERICAL                        |
| 26   | 6T3014   | 2    | ROLL PIN, 1/4" X 2"                     |
| 27   | TB1045B  | 2    | PIN, PRIMARY CYLINDER                   |

COMMON BENGAL T4

# BOOM ASSY HYD BENGAL 24 T4

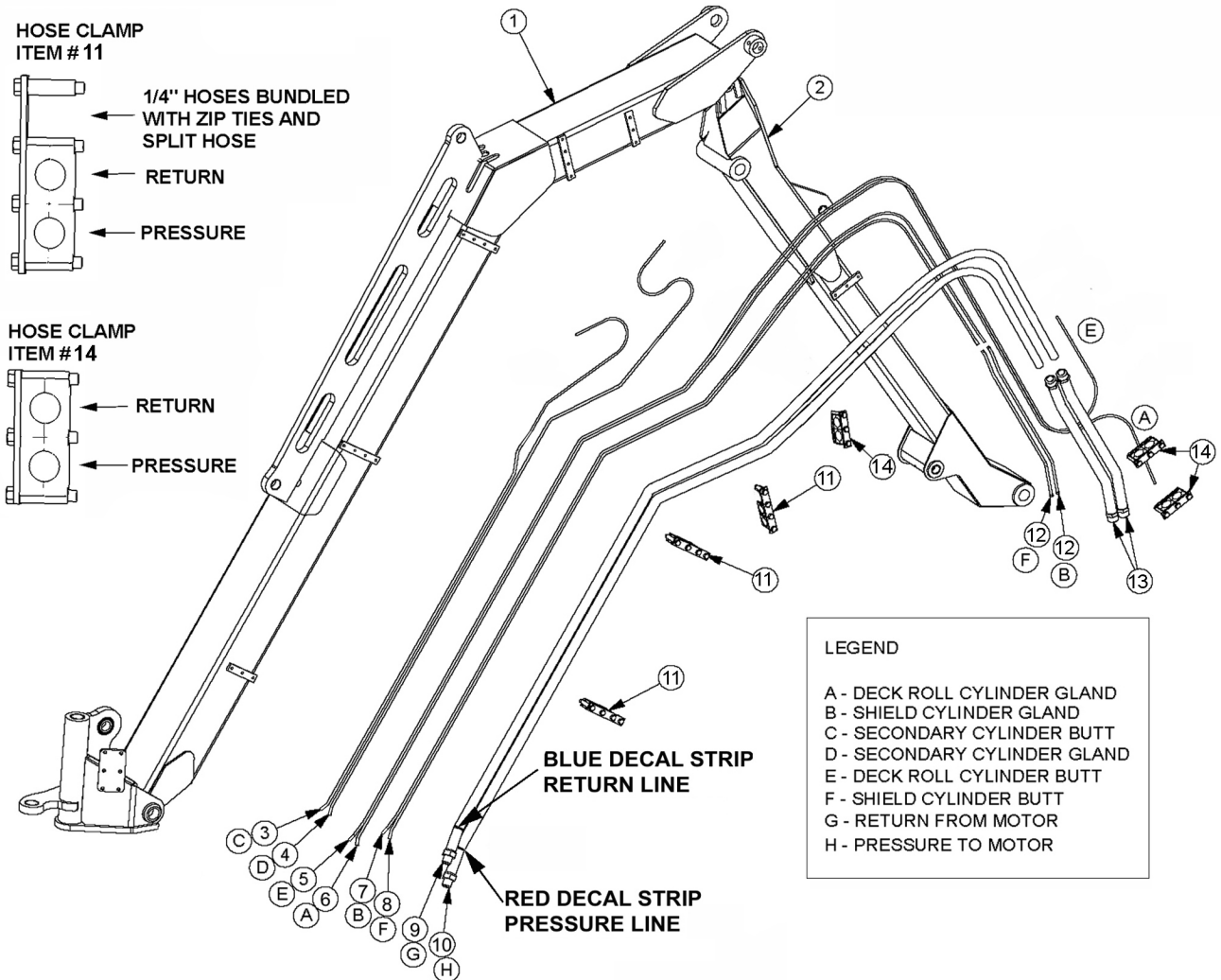

## BOOM ASSY HYD BENGAL 24 T4

Continued...

| ITEM | PART NO. | QTY. | DESCRIPTION                            |
|------|----------|------|----------------------------------------|
| 1    | -----    | -    | MAIN BOOM *REFER TO BOOM ARM ASSY      |
| 2    | -----    | -    | SECONDARY BOOM *REFER TO BOOM ARM ASSY |
| 3    | 06500716 | 1    | HOSE, 1/4" X 100"                      |
| 4    | ---      | 1    | HOSE, 1/4" X 100 "                     |
| 5    | 06500717 | 1    | HOSE, 1/4" X 170"                      |
| 6    | ----     | 1    | HOSE, 1/4" X 170"                      |
| 7    | 06500718 | 1    | HOSE, 1/4" X 130"                      |
| 8    | ---      | 1    | HOSE, 1/4" X 130"                      |
| 9    | 06500715 | 1    | HOSE, 1" X 198"                        |
| 10   | ---      | 1    | HOSE, 1" X 198"                        |
| 11   | 06505019 | 3    | CLAMP KIT,3 SECTION                    |
| 12   | 34103    | 2    | TUBE,PRFRMD,SEC BOOM                   |
| 13   | 30169    | 2    | TUBE,PRFRMD,SEC BOOM,HP                |
| 14   | 30111    | 2    | CLAMP KIT,2 SECTION                    |

COMMON BENGAL T4

# BOOMREST - OPEN STOW

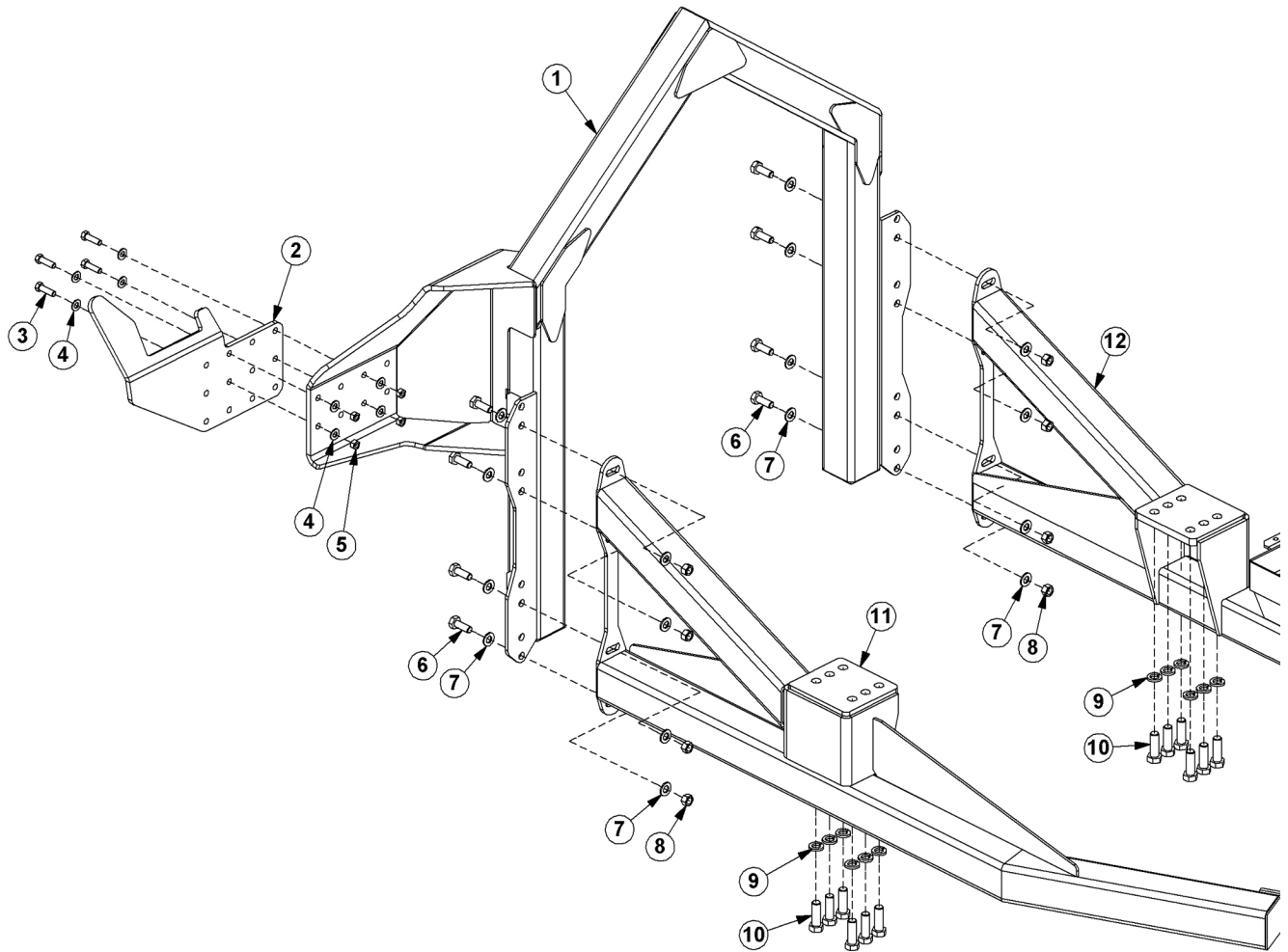

## BOOMREST - OPEN STOW

Continued...

| ITEM | PART NO. | QTY. | DESCRIPTION               |
|------|----------|------|---------------------------|
| 1    | 06310157 | 1    | BOOMREST,OS               |
| 2    | 06410968 | 1    | SADDLE                    |
| 3    | 21732    | 4    | CAPSCREW,1/2" X 1-3/4",NC |
| 4    | 06533004 | 8    | FLATWASHER,1/2",SAE       |
| 5    | 21725    | 4    | HEX NUT,1/2",NC           |
| 6    | 21782    | 8    | CAPSCREW,5/8" X 1-3/4",NC |
| 7    | 33764    | 16   | FLATWASHER,5/8",SAE       |
| 8    | 21775    | 8    | HEX NUT,5/8",NC           |
| 9    | 24881    | 12   | LOCKWASHER,20MM           |
| 10   | 27281    | 12   | CAPSCREW,20MM X 60MM,2.5P |
| 11   | ---      | 1    | AXLE BRACE,RH             |
| 12   | ----     | 1    | AXLE BRACE,LH             |

COMMON BENGAL T4

# 50IN ROTARY MOWER ASSEMBLY

LINK TO THE SHIELD (OPTIONAL)

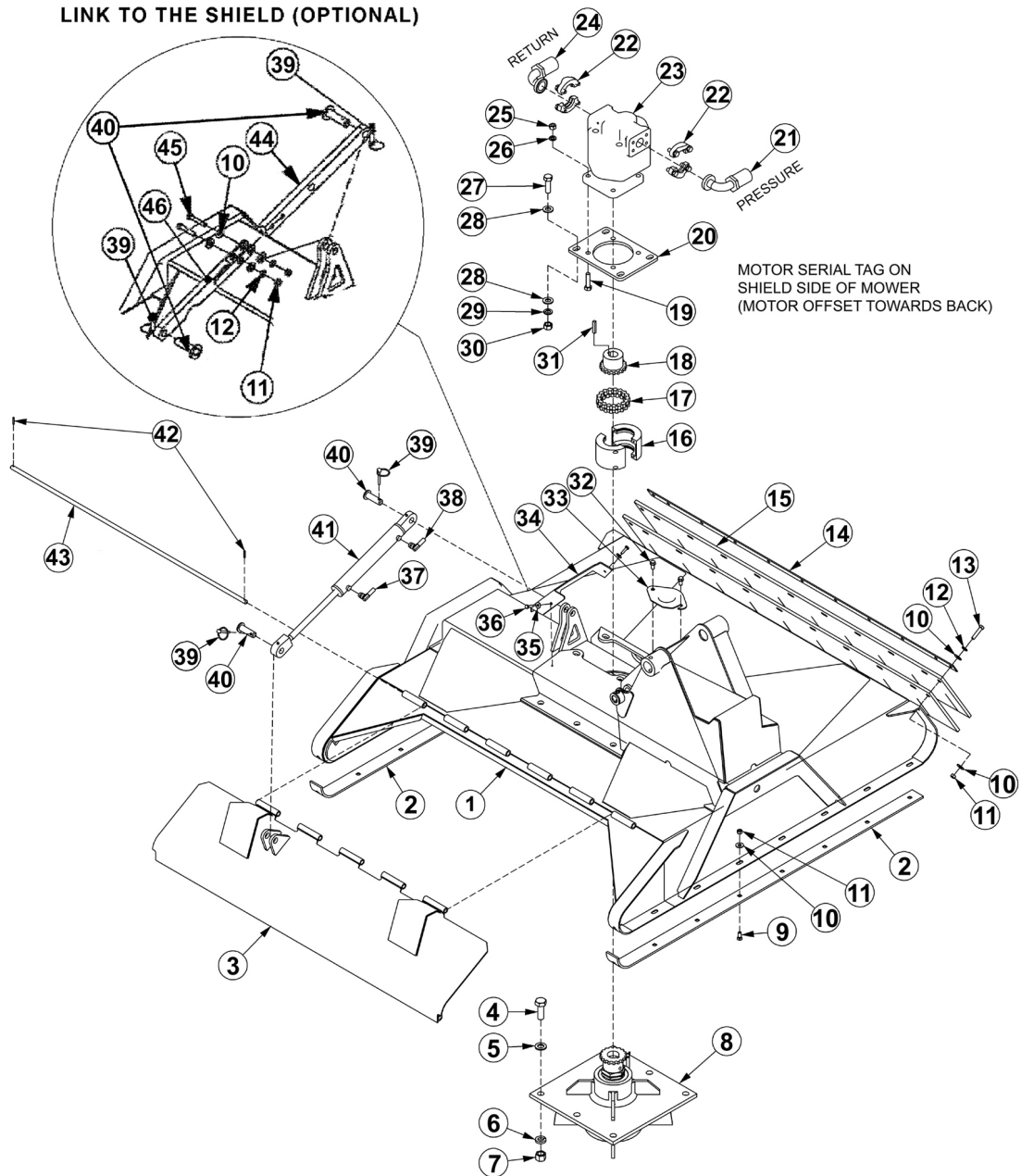

| ITEM | PART NO. | QTY. | DESCRIPTION                    |
|------|----------|------|--------------------------------|
| 1    | 33780    | 1    | DECK,WLDMNT,50" RTRY           |
| 2    | 33777    | 2    | SKID SHOE,50" RTRY             |
| 3    | 33754    | 1    | SHIELD,50"RTRY                 |
| 4    | 33879    | 6    | CAPSCREW, 3/4 X 2 1/4,NF GR 8  |
| 5    | 33880    | 6    | FLATWASHER,3/4",GR 8,SAE       |
| 6    | 21993    | 6    | LOCKWASHER,3/4",GR 8           |
| 7    | 6T2413   | 6    | HEX NUT,3/4,NF,GR 8            |
| 8    | 6T1024H5 | 1    | SPINDLE ASSY,CPLT,HD,5/8 HOLES |

## 50IN ROTARY MOWER ASSEMBLY

**Continued...**

| <b>ITEM</b> | <b>PART NO.</b> | <b>QTY.</b> | <b>DESCRIPTION</b>            |
|-------------|-----------------|-------------|-------------------------------|
| 9           | 6T2270          | 16          | PLOW BOLT,3/8" X 1" NC        |
| 10          | 22016           | 33          | FLATWASHER,3/8"               |
| 11          | 21625           | 20          | HEX NUT,3/8",NC               |
| 12          | 21988           | 11          | LOCKWASHER, 3/8"              |
| 13          | 21633           | 11          | CAPSCREW, 3/8 X 1 3/4,NC      |
| 14          | 33774           | 1           | FLAP RETAINER,50" RTRY        |
| 15          | 33775           | 2           | FLAP,50" RTRY                 |
| 16          | 6T1033          | 1           | COUPLER COVER                 |
| 17          | 6T1029          | 1           | COUPLER CHAIN                 |
| 18          | 21223           | 1           | SPROCKET                      |
| 19          | 21733           | 4           | CAPSCREW, 1/2 X 2,NC          |
| 20          | 33776           | 1           | MOTOR MOUNT,PLATE,50" RTRY    |
| 21          | 24490           | 1           | HOSE - PRESSURE               |
| ---         | 06500155        | 1           | HOSE- PRESSURE (LRS ONLY)     |
| 22          | TF4852          | 2           | FLANGE KIT - #20              |
| 23          | 06504012        | 1           | MOTOR                         |
| 24          | 24489           | 1           | HOSE - RETURN                 |
| ---         | 06500154        | 1           | HOSE-RETURN (LRS ONLY)        |
| 25          | 21725           | 4           | HEX NUT, 1/2" NC              |
| 26          | 06533004        | 4           | FLATWASHER, 1/2"              |
| 27          | 6T2290          | 4           | CAPSCREW,5/8X2,NF GR 8        |
| 28          | 33764           | 8           | FLATWASHER,5/8",GR 8,SAE      |
| 29          | 21992           | 4           | LOCKWASHER, 5/8               |
| 30          | 6T2408          | 4           | HEX NUT, 5/8, NF              |
| 31          | TF1124          | 1           | SQUARE KEY                    |
| 32          | 33881           | 2           | CAPSCREW,FLG, 3/8 X 3/4,NC    |
| 33          | 33779           | 1           | PLATE,COVER,KNF HOLE          |
| 34          | 06410439        | 1           | COVER                         |
| 35          | 22014           | 2           | FLATWASHER,1/4                |
| 36          | 21530           | 2           | CAPSCREW,1/4 X 1,NC           |
| 37          | 34187           | 1           | HOSE 1/4" X 75"               |
| 38          | 34186           | 1           | HOSE 1/4" X 66"               |
| 39          | RD1032          | 2           | LYNCH PIN                     |
| 40          | 33984           | 2           | PIN,SHIELD,50"                |
| 41          | 33785           | 1           | 1-1/2" X 8", CYLINDER, WELDED |
| 42          | 6T3017          | 2           | ROLLPIN                       |
| 43          | 33778           | 1           | HINGE PIN,50" RTRY            |
| 44          | 33772           | 1           | LINK, SHIELD 50" RTRY         |
| 45          | 21634           | 2           | CAPSCREW, 3/8" X 2, NC        |
| 46          | 33773           | 1           | LINK 2, SHIELD 50" RTRY       |

COMMON BENGAL T4

## 50IN ROTARY KNIVES AND DISH

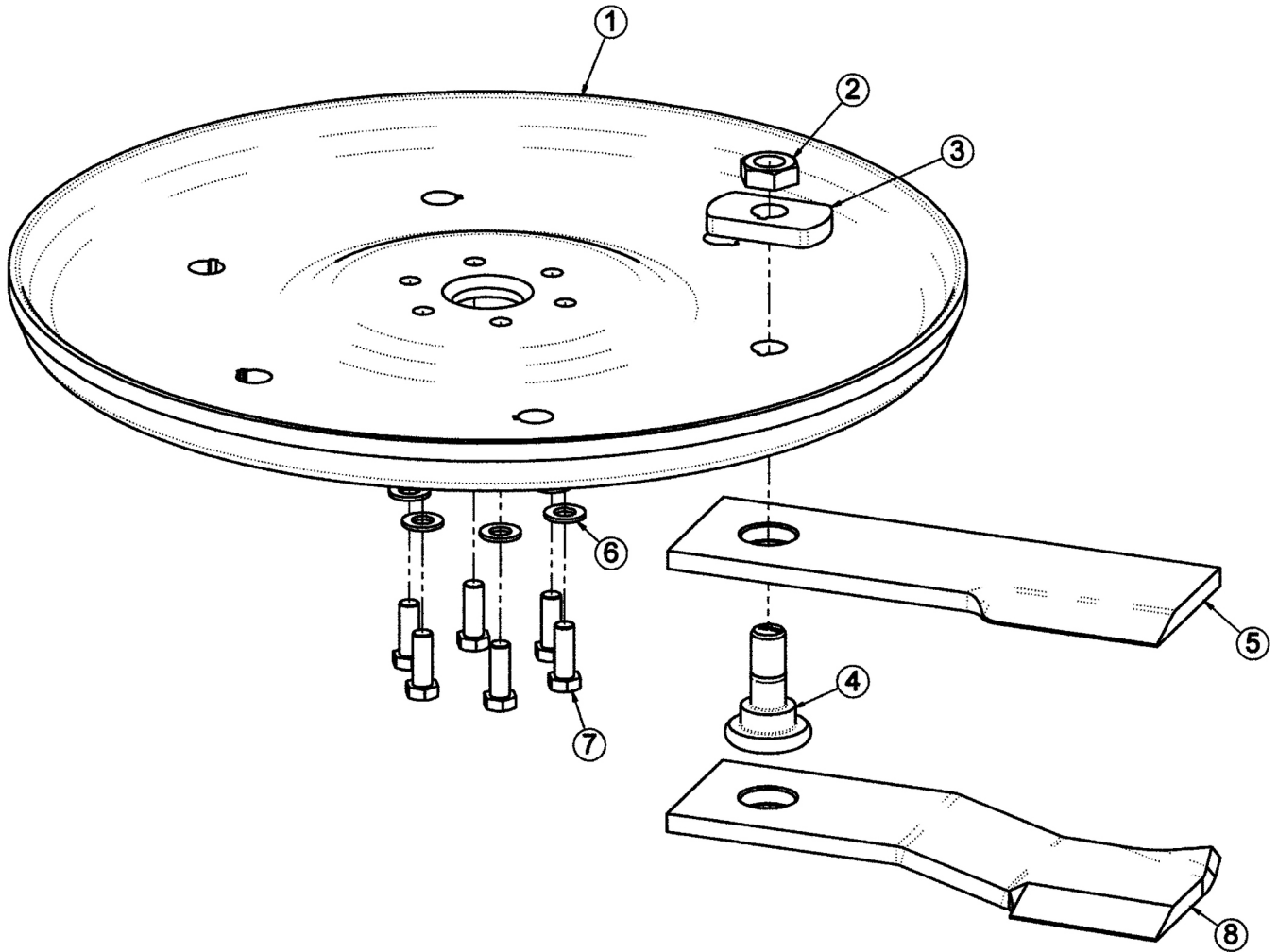

| ITEM  | PART NO. | QTY. | DESCRIPTION                                        |
|-------|----------|------|----------------------------------------------------|
| ----- | 06700089 | -    | KIT,TRB50,DISK,W/BOLT KIT (INCLUDES ITEMS 1,3 & 7) |
| 1     | 06770003 | 1    | BLADE MOUNTING DISK                                |
| 2     | 6T1023R  | 2    | NYLOCK HEX NUT 1 1/8"                              |
| 3     | 34878    | 2    | SPACER                                             |
| 4     | 06538000 | 2    | KNIFE MOUNTING BOLT                                |
| 5     | 06521001 | 2    | STANDARD KNIFE                                     |
| 6     | 33764    | 6    | FLATWASHER                                         |
| 7     | 6T2259   | 6    | CAPSCREW                                           |
| ----- | 06770012 | -    | BOLT KIT (INCLUDES ITEMS 6, 7 & LOCTITE)           |
| 8     | 06521002 | 2    | GRASS KNIFE (OPTIONAL)                             |
| ----- | 6T1825   | -    | LOCTITE - USED ON ALL DISK MOUNTING BOLTS          |



## 50IN ROTARY BLADE BAR AND KNIVES

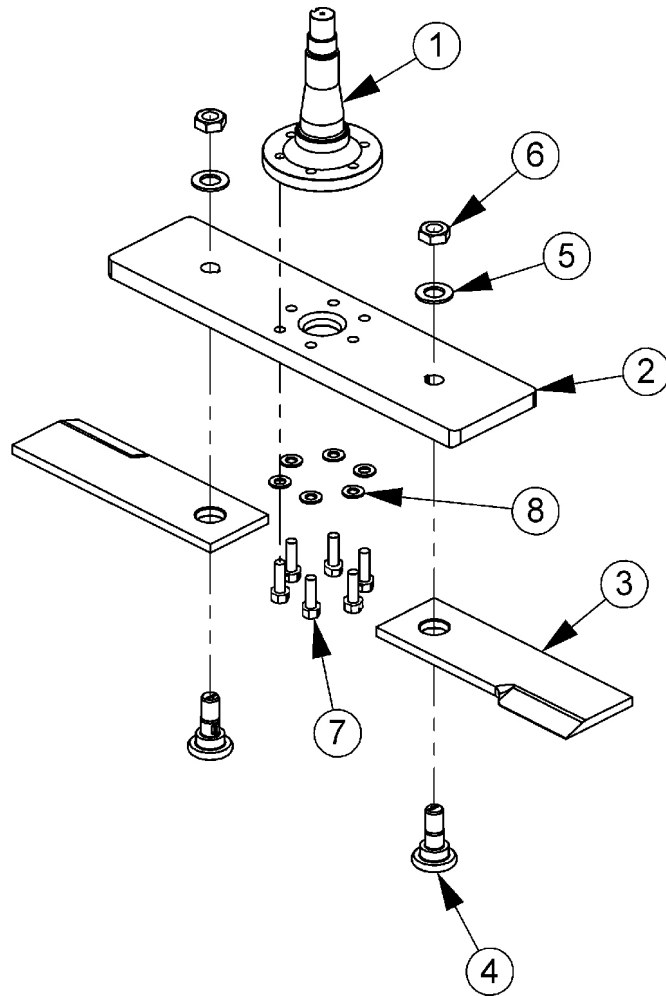

| ITEM | PART NO. | QTY. | DESCRIPTION                 |
|------|----------|------|-----------------------------|
| 1    | PT1018H5 | 1    | SPINDLE,5/8HOLES,HD,WO/TABS |
| 2    | 06400388 | 1    | BAR,BLADE,TRB               |
| 3    | 06521001 | 2    | KNIFE,TRB50,5/8             |
| 4    | 06538000 | 2    | KNIFE MTG BOLT,5/8 SHOULDER |
| 5    | 06533002 | 2    | FLATWASHER,1 1/8,GR 8       |
| 6    | 6T1023R  | 2    | KNIFE MTG NUT,1 1/8,NF,GR8  |
| 7    | 6T2259   | 6    | CAPSCREW,5/8X1-3/4,NF,GR8   |
| 8    | 33764    | 6    | FLATWASHER,5/8,GR 8,SAE     |

# 60IN ROTARY MOWER ASSEMBLY

LINK TO THE SHIELD (OPTIONAL)

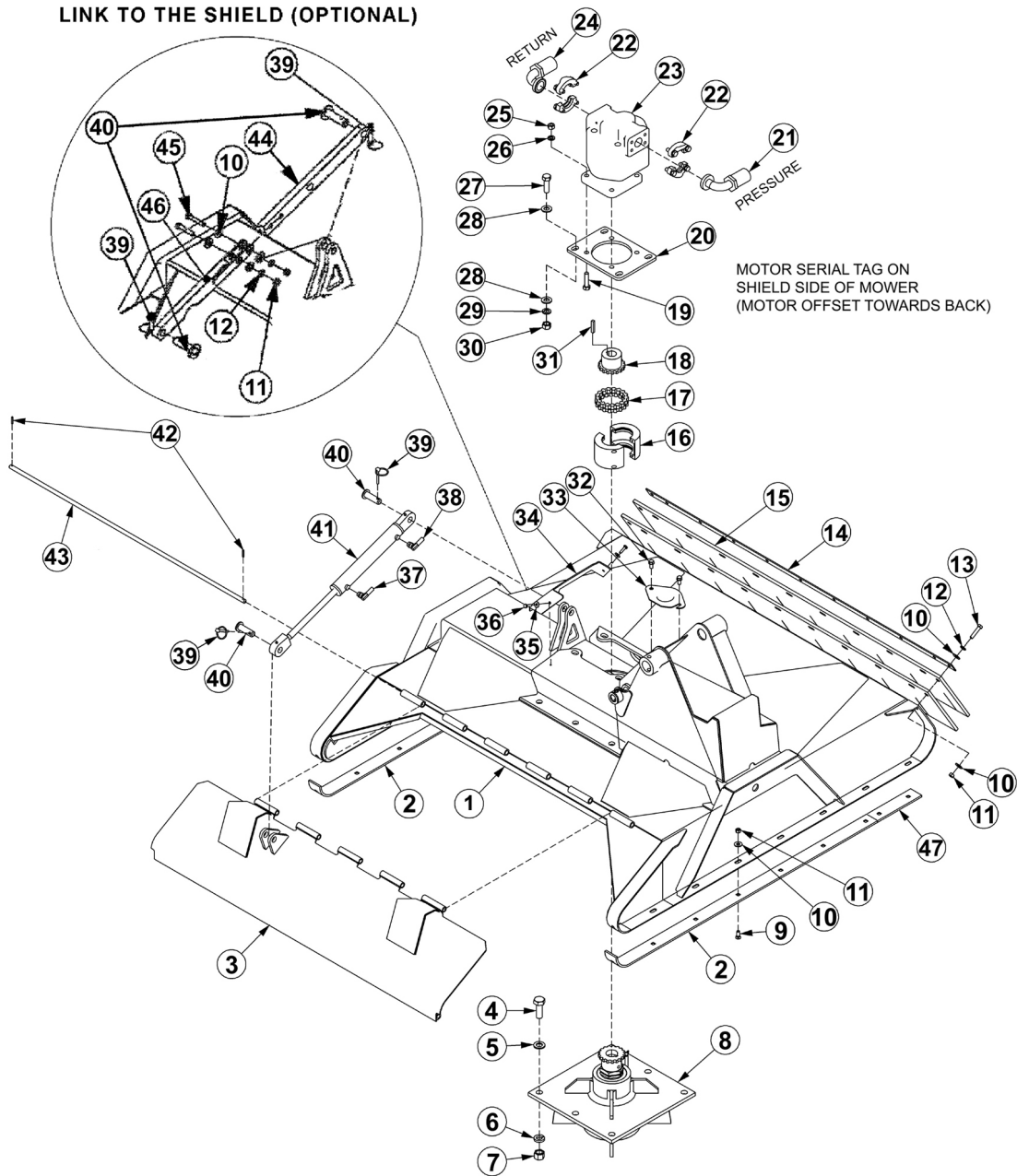

| ITEM | PART NO. | QTY. | DESCRIPTION                    |
|------|----------|------|--------------------------------|
| 1    | 06320159 | 1    | DECK,WLDMNT,60" RTRY           |
| 2    | 33777    | 2    | SKID SHOE,RTRY                 |
| 3    | 06320162 | 1    | SHIELD,60"RTRY                 |
| 4    | 33879    | 6    | CAPSCREW, 3/4 X 2 1/4,NF GR 8  |
| 5    | 33880    | 6    | FLATWASHER,3/4",GR 8,SAE       |
| 6    | 21993    | 6    | LOCKWASHER,3/4",GR 8           |
| 7    | 6T2413   | 6    | HEX NUT,3/4,NF,GR 8            |
| 8    | 6T1024H5 | 1    | SPINDLE ASSY,CPLT,HD,5/8 HOLES |

## 60IN ROTARY MOWER ASSEMBLY

Continued...

| ITEM | PART NO. | QTY. | DESCRIPTION                   |
|------|----------|------|-------------------------------|
| 9    | 6T2270   | 16   | PLOW BOLT,3/8" X 1" NC        |
| 10   | 22016    | 33   | FLATWASHER,3/8"               |
| 11   | 21625    | 20   | HEX NUT,3/8",NC               |
| 12   | 21988    | 11   | LOCKWASHER, 3/8"              |
| 13   | 21633    | 11   | CAPSCREW, 3/8 X 1 3/4,NC      |
| 14   | 6T0823   | 1    | FLAP RETAINER,60" RTRY        |
| 15   | 06520238 | 2    | FLAP,60" RTRY                 |
| 16   | 6T1033   | 1    | COUPLER COVER                 |
| 17   | 6T1029   | 1    | COUPLER CHAIN                 |
| 18   | 21223    | 1    | SPROCKET                      |
| 19   | 21733    | 4    | CAPSCREW, 1/2 X 2,NC          |
| 20   | 33776    | 1    | MOTOR MOUNT,PLATE,RTRY        |
| 21   | 24490    | 1    | HOSE - PRESSURE               |
| ---  | 06500155 | 1    | HOSE-PRESSURE (LRS ONLY)      |
| 22   | TF4852   | 2    | FLANGE KIT - #20              |
| 23   | 6504011  | 1    | MOTOR                         |
| 24   | 24489    | 1    | HOSE - RETURN                 |
| ---  | 06500154 | 1    | HOSE-RETURN (LRS ONLY)        |
| 25   | 21725    | 4    | HEX NUT, 1/2" NC              |
| 26   | 06533004 | 4    | FLATWASHER, 1/2"              |
| 27   | 6T2290   | 4    | CAPSCREW,5/8X2,NF GR 8        |
| 28   | 33764    | 8    | FLATWASHER,5/8",GR 8,SAE      |
| 29   | 21992    | 4    | LOCKWASHER, 5/8               |
| 30   | 6T2408   | 4    | HEX NUT, 5/8, NF              |
| 31   | TF1124   | 1    | SQUARE KEY                    |
| 32   | 33881    | 2    | CAPSCREW,FLG, 3/8 X 3/4,NC    |
| 33   | 33779    | 1    | PLATE,COVER,KNF HOLE          |
| 34   | 06410439 | 1    | COVER                         |
| 35   | 22014    | 2    | FLATWASHER,1/4                |
| 36   | 21530    | 2    | CAPSCREW,1/4 X 1,NC           |
| 37   | 34187    | 1    | HOSE 1/4" X 75"               |
| 38   | 34186    | 1    | HOSE 1/4" X 66"               |
| 39   | RD1032   | 2    | LYNCH PIN                     |
| 40   | 33984    | 2    | PIN,SHIELD                    |
| 41   | 33785    | 1    | 1-1/2" X 8", CYLINDER, WELDED |
| 42   | 6T3017   | 2    | ROLLPIN                       |
| 43   | 06420139 | 1    | HINGE PIN,60" RTRY            |
| 44   | 33772    | 1    | LINK, SHIELD,RTRY             |
| 45   | 21634    | 2    | CAPSCREW, 3/8" X 2, NC        |
| 46   | 33773    | 1    | LINK 2, SHIELD,RTRY           |
| 47   | 06401245 | 2    | SKID SHOE,TRB60               |

COMMON BENGAL T4

## 60IN ROTARY KNIVES AND DISH

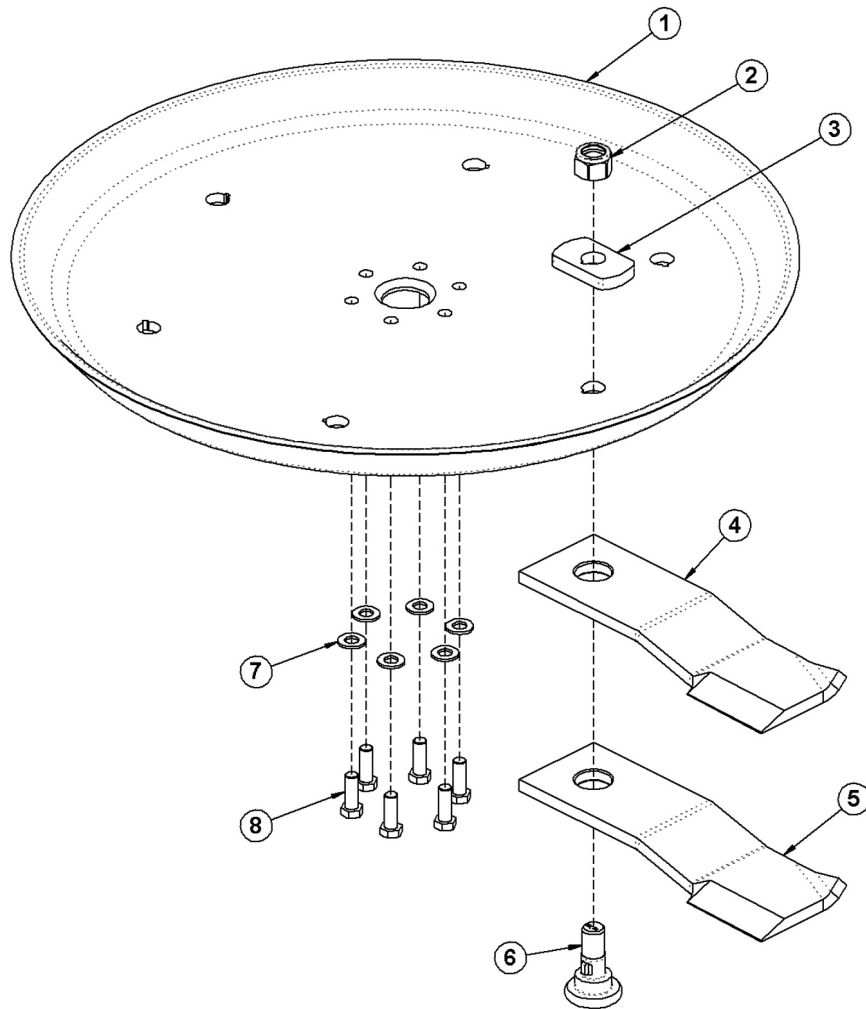

| ITEM | PART NO. | QTY. | DESCRIPTION                         |
|------|----------|------|-------------------------------------|
| 1    | 34876    | 1    | BLADE MOUNTING DISH,60"             |
| 2    | 6T1023R  | 2    | NYLOCK NUT,1-1/8",NF                |
| 3    | 34878    | 2    | SPACER                              |
| 4    | 34684    | 2    | STANDARD GRASS KNIFE                |
| 5    | 34685    | 2    | HIGH SUCTION GRASS KNIFE (OPTIONAL) |
| 6    | 34497    | 2    | KNIFE MOUNTING BOLT                 |
| 7    | 25270    | 6    | FLATWASHER,5/8",GR8,USS             |
| 8    | 6T2259   | 6    | CAPSCREW,5/8" X 1-3/4",NF,GR8       |
| ---  | 6T1825   | 1    | LOCKTITE (USED ON ITEM 8)           |
| ---  | 27167    | 1    | BOLT KIT (ITEMS 7 & 8)              |
| ---  | 33893    | 1    | KNIFE KIT (ITEMS 2,4 & 6)           |

## 60IN ROTARY BLADE BAR AND KNIVES

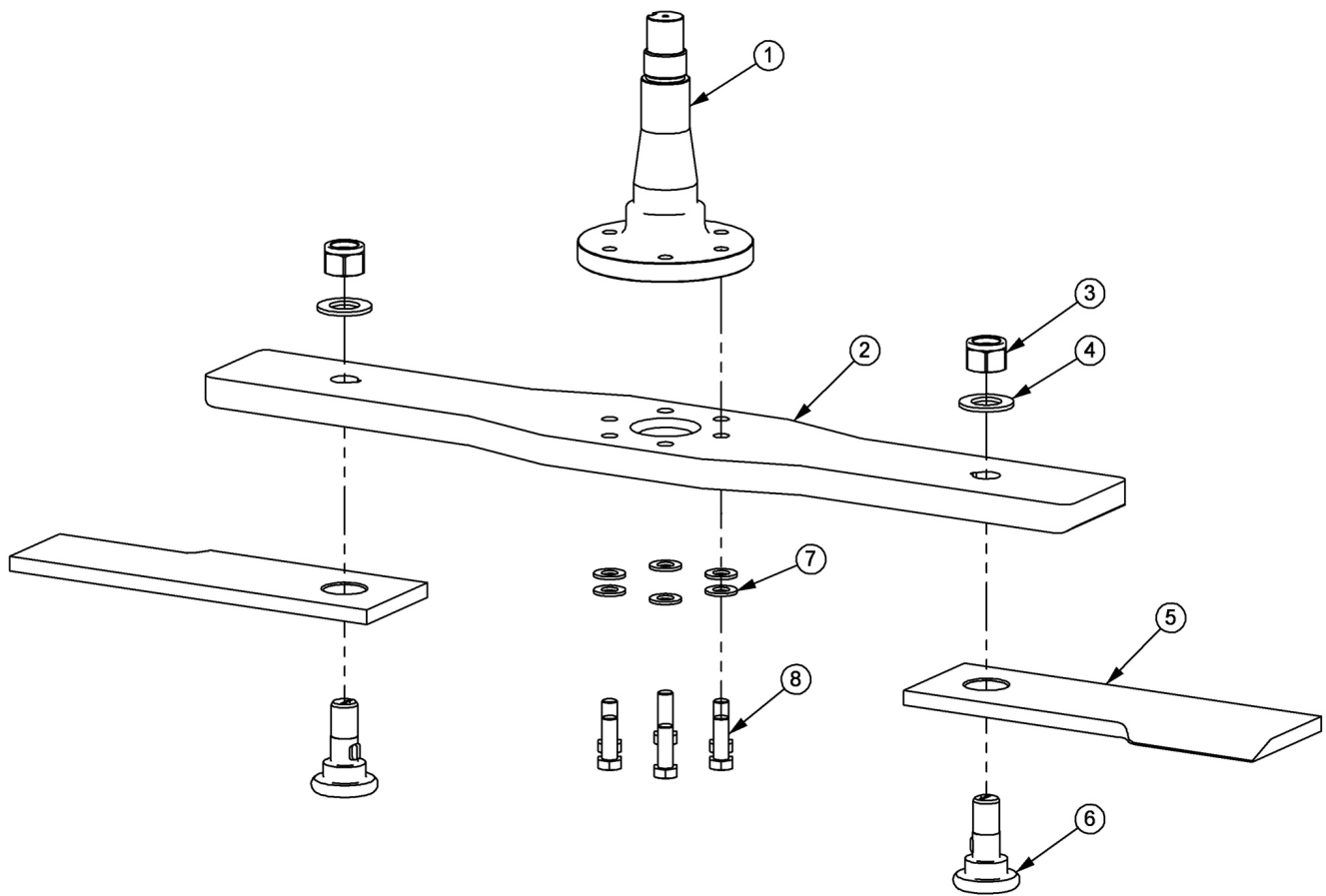

| ITEM | PART NO. | QTY. | DESCRIPTION                      |
|------|----------|------|----------------------------------|
| 1    | PT1018H5 | 1    | SPINDLE                          |
| 2    | 06400690 | 1    | BAR, BLADE, RTRY60               |
| 3    | 6T1023R  | 2    | KNIFE MTG NUT, 1-1/8, NYLOCK, NF |
| 4    | 06533002 | 2    | FLATWASHER, 1-1/8, GR8           |
| 5    | 06521001 | 2    | KNIFE, TRB50, 5/8                |
| 6    | 06538000 | 2    | KNIFE MTG BOLT, 5/8 SHOULDER     |
| 7    | 33764    | 6    | FLATWASHER, 5/8, GR 8, SAE       |
| 8    | 6T2259   | 6    | CAPSCREW, 5/8 X 1-3/4, NF, GR8   |

# ROTARY MOWER SPINDLE ASSEMBLY

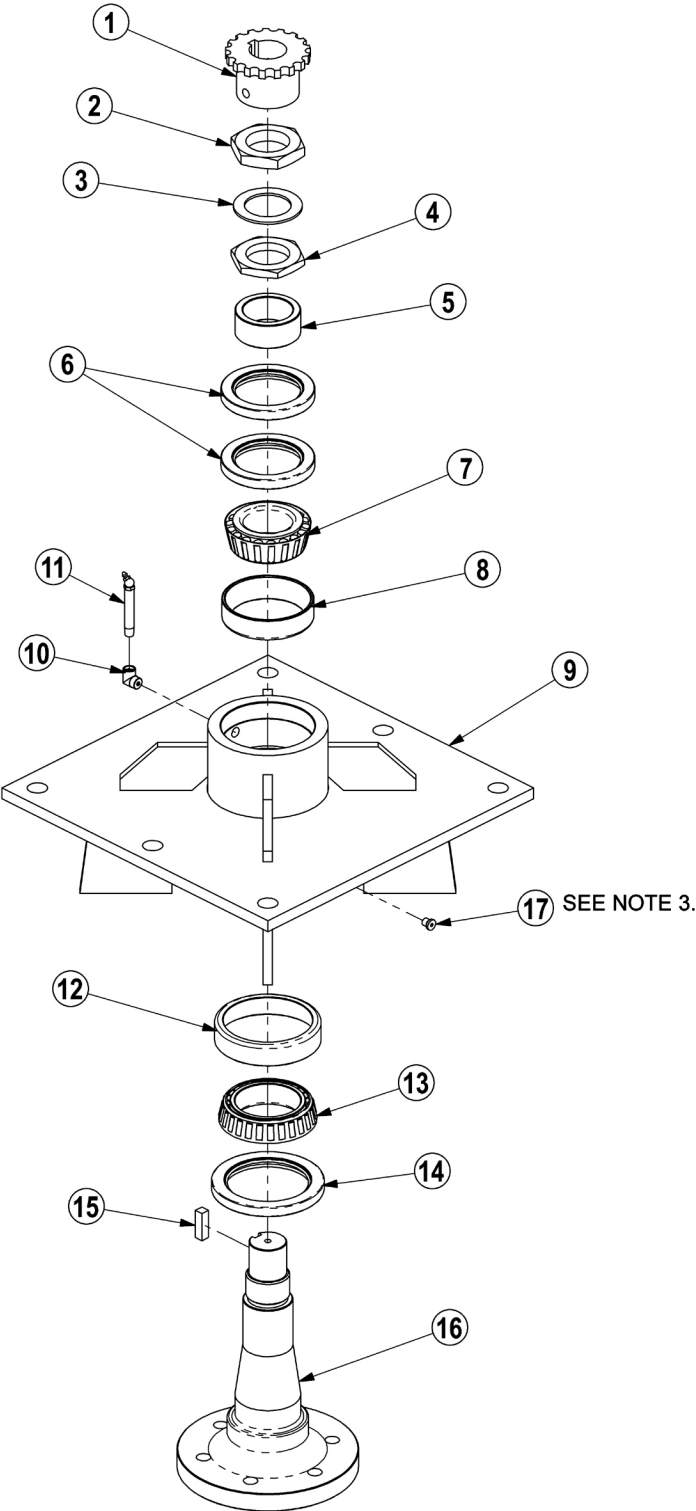

- NOTES:
1. FREEPLAY: .001" - .003"
  2. GREASE: FILL WITH MOBILITH SHC 220.
  3. APPLY LOCTITE "271" TO O-RING PLUG THRDS.

## ROTARY MOWER SPINDLE ASSEMBLY

Continued...

| ITEM  | PART NO. | QTY. | DESCRIPTION                                            |
|-------|----------|------|--------------------------------------------------------|
| ----- | 6T1024H5 | -    | SPINDLE ASSEMBLY COMPLETE                              |
| 1     | 6T1031   | 1    | SPROCKET                                               |
| 2     | 6T1016   | 1    | BEARING LOCK NUT - THICK                               |
| 3     | 22596    | 1    | JAM WASHER                                             |
| 4     | 6T1015   | 1    | BEARING ADJUSTMENT NUT - THIN                          |
| 5     | 6T1014   | 1    | BEARING ADJUSTMENT SLEEVE                              |
| 6     | 6T1011   | 1    | UPPER SEAL - SET OF 2                                  |
| 7     | 6T1012   | 1    | BEARING CONE                                           |
| 8     | 6T1013   | 1    | BEARING CUP                                            |
| 9     | 6T1010H  | 1    | SPINDLE HOUSING                                        |
| 10    | 30570    | 1    | FITTING STREET ELBOW                                   |
| 11    | 33990    | 1    | GREASE ZERK                                            |
| 12    | 6T1013H  | 1    | BEARING CUP                                            |
| 13    | 6T1012H  | 1    | BEARING CONE                                           |
| 14    | 6T1011H  | 1    | LOWER SEAL                                             |
| 15    | 6T1019   | 1    | SPINDLE KEY                                            |
| 16    | PT1018H5 | 1    | SPINDLE                                                |
| 17    | 06503064 | 1    | O-RING PLUG, 1/8"                                      |
| ----- | 31771    | -    | SPINDLE REBUILD KIT (INCLUDES ITEMS 2 - 8 AND 12 - 15) |

# BOOM ROTARY PIVOT ASSEMBLY

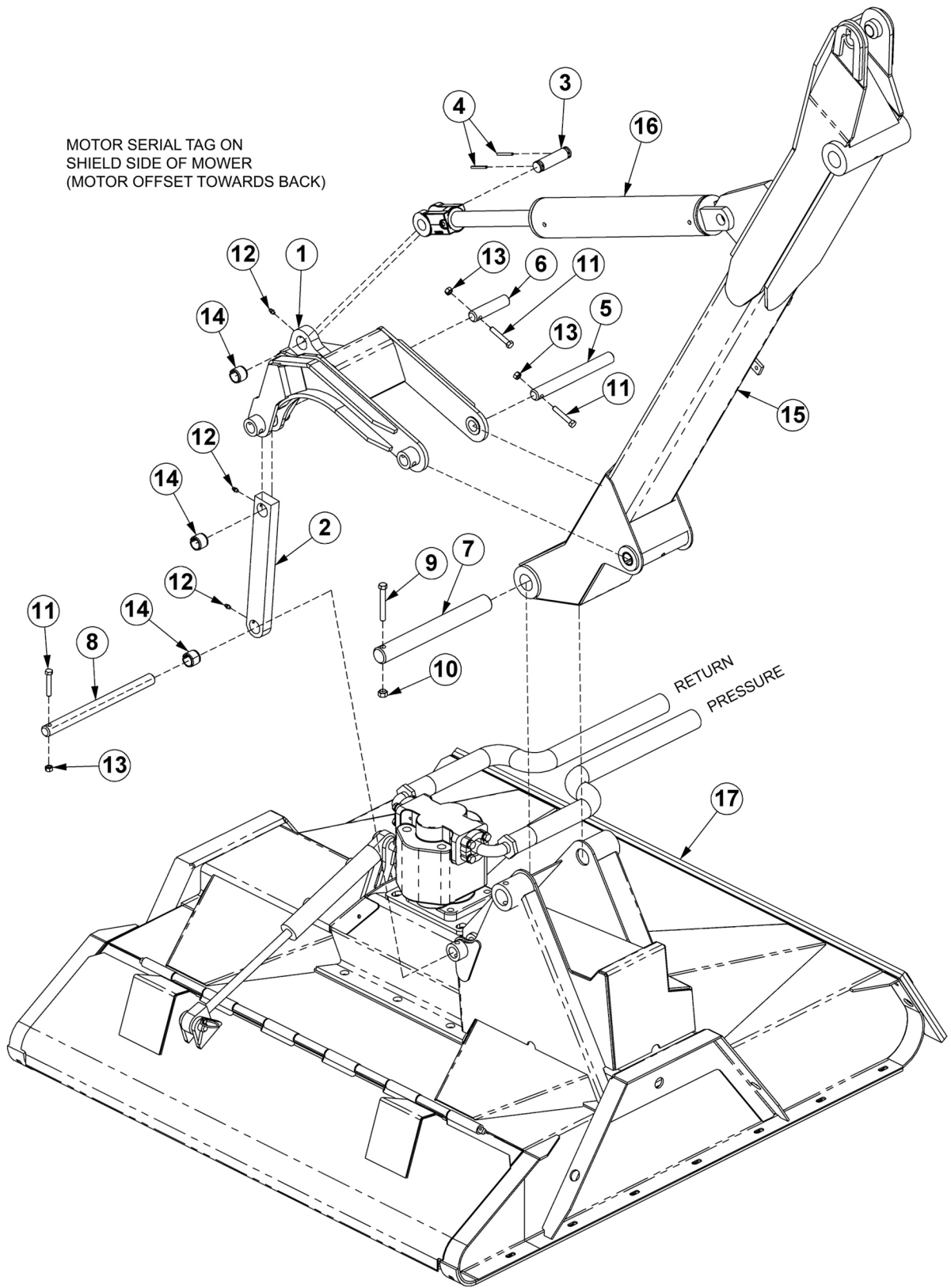



## BOOM ROTARY PIVOT ASSEMBLY

Continued...

| ITEM | PART NO. | QTY. | DESCRIPTION                             |
|------|----------|------|-----------------------------------------|
| 1    | TB1032   | 1    | ROTARY PIVOT ASSY                       |
| 2    | TB1028   | 1    | PIVOT ARM ASSY                          |
| 3    | TB1033   | 1    | PIN,CLEVIS                              |
| 4    | 06537021 | 2    | ROLL PIN                                |
| 5    | TF3097   | 1    | PIN                                     |
| 6    | TB1030   | 1    | PIN                                     |
| 7    | 33985    | 1    | PIN                                     |
| 8    | 33986    | 1    | PIN                                     |
| 9    | 21688    | 1    | CAPSCREW,7/16 X 3-1/4,NC                |
| 10   | 21677    | 1    | NYLOCK NUT,7/16 NC                      |
| 11   | 21635    | 3    | CAPSCREW,3/8 X 2-1/4                    |
| 12   | 6T3207   | 3    | GREASE ZERK                             |
| 13   | 21627    | 3    | NYLOCK NUT,3/8,NC                       |
| 14   | TB3010   | 3    | BUSHING                                 |
| 15   | -----    | -    | SECONDARY BOOM *REFER TO BOOM ARM ASSY  |
| 16   | -----    | -    | CYLINDER *REFER TO BOOM ARM ASSY        |
| 17   | -----    | -    | ROTARY MOWER HEAD *REFER TO ROTARY DECK |

# 50IN FLAIL DRIVE ASSEMBLY

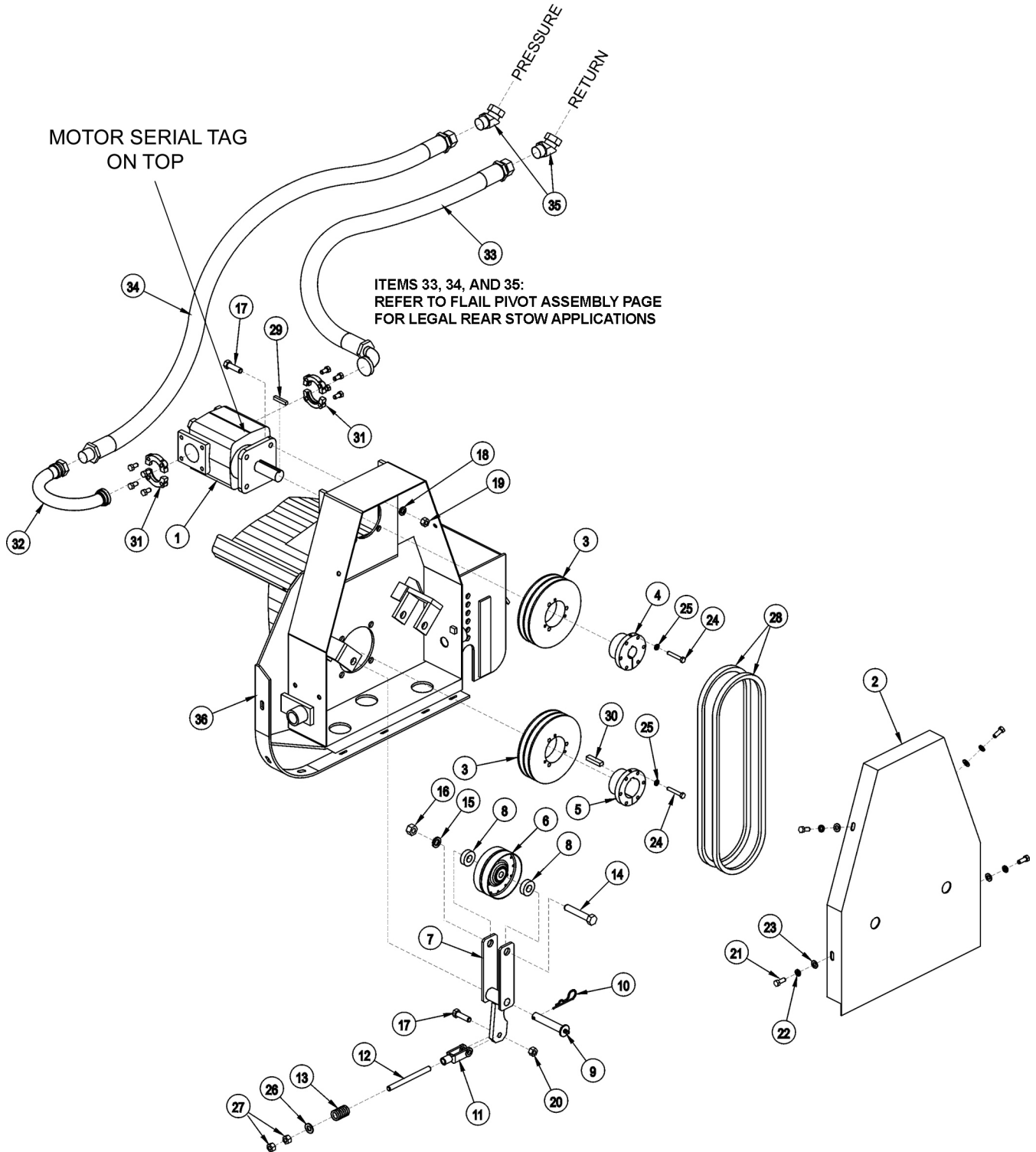

## 50IN FLAIL DRIVE ASSEMBLY

Continued...

| ITEM | PART NO. | QTY. | DESCRIPTION                            |
|------|----------|------|----------------------------------------|
| 1    | 06504132 | 1    | MOTOR (M350-1 3/4" GEAR)               |
| 2    | TF3006   | 1    | BELT GUARD                             |
| 3    | TF3043   | 2    | SHEAVE                                 |
| 4    | TF3013   | 1    | BUSHING                                |
| 5    | TF3011   | 1    | BUSHING                                |
| 6    | TF3034   | 1    | IDLER PULLEY                           |
| 7    | TF3205   | 1    | IDLER ARM                              |
| 8    | TF3206   | 2    | IDLER PULLEY SPACER                    |
| 9    | TF3605   | 1    | IDLER ARM PIN WITH ZERK                |
| 10   | 6T3004   | 1    | R - CLIP                               |
| 11   | PT3611A  | 1    | CLEVIS                                 |
| 12   | 32481    | 1    | THREADED ROD                           |
| 13   | TF3620   | 1    | COMPRESSION SPRING                     |
| 14   | 21789    | 1    | CAPSCREW 5/8" X 3 1/2"                 |
| 15   | 21992    | 1    | LOCKWASHER 5/8"                        |
| 16   | 21775    | 1    | HEX NUT 5/8"                           |
| 17   | 21732    | 5    | CAPSCREW 1/2" X 1 3/4"                 |
| 18   | 21990    | 4    | LOCKWASHER 1/2"                        |
| 19   | 21725    | 4    | HEX NUT 1/2"                           |
| 20   | 6T2418   | 1    | LOCK NUT 1/2"                          |
| 21   | 21630    | 4    | CAPSCREW 3/8" X 1"                     |
| 22   | 21988    | 4    | LOCKWASHER 3/8"                        |
| 23   | 22016    | 4    | FLATWASHER 3/8"                        |
| 24   | 21584    | 6    | CAPSCREW 5/16" X 2"                    |
| 25   | 21987    | 6    | LOCKWASHER 5/16"                       |
| 26   | 27938    | 1    | FLATWASHER 1/2"                        |
| 27   | 21700    | 2    | HEX NUT 1/2" NF                        |
| 28   | TF3021   | 2    | BELT                                   |
| 29   | TF1125   | 1    | SQUARE KEY                             |
| 30   | TF1025   | 1    | SQUARE KEY MOTOR                       |
| 31   | TF4852   | 2    | FLANGE KIT                             |
| 32   | 34227    | 1    | PREFORMED TUBE                         |
| 33   | 31218    | 1    | HOSE - RETURN                          |
| 34   | 34331    | 1    | HOSE - PRESSURE                        |
| 35   | 24724    | 2    | SWIVEL FITTING                         |
| 36   | -----    | -    | CUTTER HEAD *REFER TO CUTTER HEAD ASSY |

# 50IN FLAIL MOWER ASSEMBLY

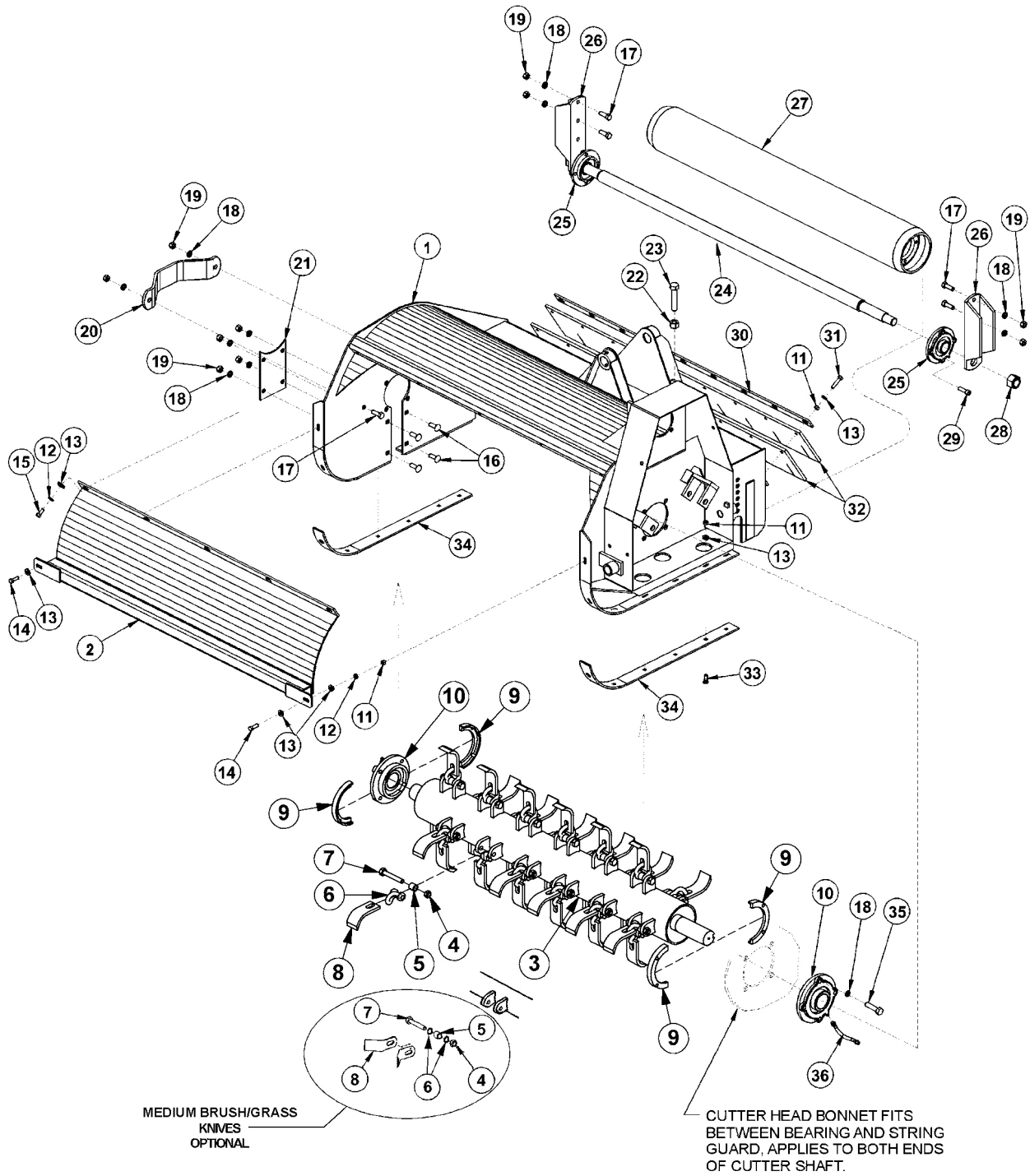

| ITEM | PART NO. | QTY. | DESCRIPTION                                           |
|------|----------|------|-------------------------------------------------------|
| ---  | 34787    | 1    | FLAIL,BOOM,50,BRUSH,CPLT ASSY (LIGHT BRUSH/GRASS)     |
|      | 06742133 | 1    | FLAIL,BOOM,50,MD GRASS,CPLT ASSY (MEDIUM BRUSH/GRASS) |
| 1    | TF3003F  | 1    | CUTTER HEAD BONNET                                    |
| 2    | TF3004   | 1    | FRONT SHIELD                                          |

## 50IN FLAIL MOWER ASSEMBLY

Continued...

| ITEM | PART NO.   | QTY. | DESCRIPTION                           |
|------|------------|------|---------------------------------------|
| 3    | 34783      | 1    | TBF50 (LIGHT BRUSH/GRASS KNIFE ASSY)  |
| ---- | 06700115   | 1    | TBF50 (MEDIUM BRUSH/GRASS KNIFE ASSY) |
| 4    | 6T2419     | 24   | HEX NUT,9/16",NC,STOVER               |
| 5    | 41725.01HT | 24   | BUSHING,1"OD X 5/8"ID                 |
| 6    | 34782      | 24   | CLEVIS (LIGHT BRUSH/GRASS KNIVES)     |
| ---- | 06430122   | 48   | SPACER (MEDIUM BRUSH/GRASS KNIVES)    |
| 7    | 34786      | 24   | CAPSCREW,9/16" X 3-1/2",NC            |
| 8    | 34780      | 24   | KNIFE (LIGHT BRUSH/GRASS CUTTING)     |
| ---- | 06521007   | 48   | KNIFE (MEDIUM BRUSH/GRASS CUTTING)    |
| 9    | 31204      | 2    | STRING GUARD SET (2 PIECES PER SET)   |
| 10   | TF1018     | 2    | FLANGE BEARING,2-3/16"                |
| 11   | 21625      | 23   | HEX NUT,3/8",NC                       |
| 12   | 21988      | 7    | LOCKWASHER,3/8"                       |
| 13   | 22016      | 30   | FLATWASHER,3/8"                       |
| 14   | 21631      | 2    | CAPSCREW,3/8" X 1-1/4",NC             |
| 15   | 21630      | 5    | CAPSCREW,3/8" X 1",NC                 |
| 16   | 6T7031D    | 4    | PLOW BOLT,1/2" X 1-1/2",NC            |
| 17   | 21731      | 6    | CAPSCREW,1/2" X 1-1/2",NC             |
| 18   | 21990      | 18   | LOCKWASHER,1/2"                       |
| 19   | 21725      | 10   | HEX NUT,1/2",NC                       |
| 20   | TF1040     | 1    | CUTTER SHAFT GUARD                    |
| 21   | TF3007A    | 1    | COVER PLATE                           |
| 22   | 21825      | 1    | HEX NUT,5/8",NC                       |
| 23   | 21838      | 1    | CAPSCREW,3/4" X 3-1/2",NC             |
| 24   | TF3406     | 1    | GROUND ROLLER TIE ROD                 |
| 25   | TF1022     | 2    | FLANGE BEARING,1-3/8"                 |
| 26   | TF3407     | 2    | GROUND ROLLER ADJUSTMENT BRACKET      |
| 27   | TF3405     | 1    | GROUND ROLLER                         |
| 28   | 6T1023R    | 2    | NYLOCK NUT,1-1/8",NF                  |
| 29   | 6T2330     | 8    | CAPSCREW,7/16" X 1-1/2",SOCKET HEAD   |
| 30   | TB1008     | 1    | FLAP RETAINING BAR                    |
| 31   | 21633      | 9    | CAPSCREW,3/8" X 1-3/4",NC             |
| 32   | TB1006A    | 2    | DEFLECTOR FLAP                        |
| 33   | 6T2270     | 12   | PLOWBOLT,3/8" X 1",NC                 |
| 34   | TF3001     | 2    | SKID SHOE                             |
| 35   | 06530218   | 8    | CAPSCREW,1/2" X 1-3/4",NC             |
| 36   | TF1032     | 1    | FLANGE BEARING GREASE HOSE            |

COMMON BENGAL T4

# 50IN FLAIL MOWER ASSY, PASS-THROUGH KNIVES

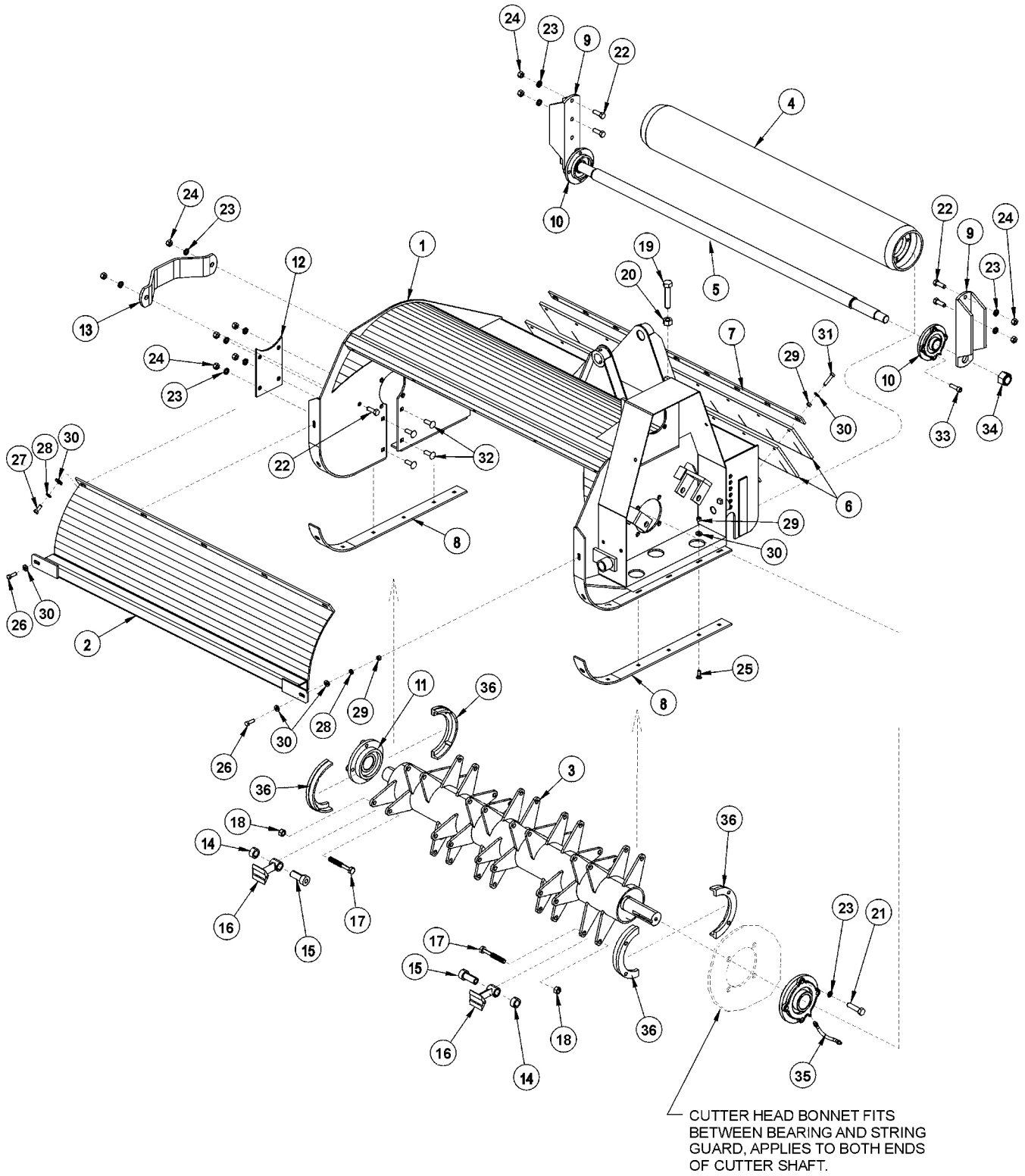

## 50IN FLAIL MOWER ASSY, PASS-THROUGH KNIVES

Continued...

| ITEM | PART NO. | QTY. | DESCRIPTION                         |
|------|----------|------|-------------------------------------|
| ---  | 34172    | 1    | FLAIL,BOOM,50,CPLT ASSY             |
| 1    | TF3003F  | 1    | CUTTER HEAD BONNET                  |
| 2    | TF3004   | 1    | FRONT SHIELD                        |
| 3    | 33717    | 1    | TBF50,CUTTERSHAFT,PASS THRU KNIVES  |
| 4    | TF3405   | 1    | GROUND ROLLER                       |
| 5    | TF3406   | 1    | GROUND ROLLER TIE ROD               |
| 6    | TB1006A  | 2    | DEFLECTOR FLAP                      |
| 7    | TB1008   | 1    | FLAP RETAINING BAR                  |
| 8    | TF3001   | 2    | SKID SHOE                           |
| 9    | TF3407   | 2    | GROUND ROLLER ADJUSTMENT BRACKET    |
| 10   | TF1022   | 2    | FLANGE BEARING,1-3/8"               |
| 11   | TF1018   | 2    | FLANGE BEARING,2-3/16"              |
| 12   | TF3007A  | 1    | COVER PLATE                         |
| 13   | TF1040   | 1    | CUTTER SHAFT GUARD                  |
| 14   | 33858    | 24   | SPACER,COLLAR                       |
| 15   | 33857    | 24   | SHOULDER,BUSHING                    |
| 16   | 46399.01 | 24   | KNIFE,FLAIL,FORGED                  |
| 17   | 33854    | 24   | CAPSCREW,5/8" X 4-1/2",NC           |
| 18   | 32674    | 24   | HEX NUT,5/8",NC                     |
| 19   | 21838    | 1    | CAPSCREW,3/4" X 3-1/2",NC           |
| 20   | 21825    | 1    | HEX NUT,5/8",NC                     |
| 21   | 21732    | 8    | CAPSCREW,1/2" X 1-3/4",NC           |
| 22   | 21731    | 6    | CAPSCREW,1/2" X 1-1/2",NC           |
| 23   | 21990    | 18   | LOCKWASHER,1/2"                     |
| 24   | 21725    | 10   | HEX NUT,1/2",NC                     |
| 25   | 6T2270   | 12   | PLOWBOLT,3/8" X 1",NC               |
| 26   | 21631    | 2    | CAPSCREW,3/8" X 1-1/4",NC           |
| 27   | 21630    | 5    | CAPSCREW,3/8" X 1",NC               |
| 28   | 21988    | 7    | LOCKWASHER,3/8"                     |
| 29   | 21625    | 23   | HEX NUT,3/8",NC                     |
| 30   | 22016    | 30   | FLATWASHER,3/8"                     |
| 31   | 21633    | 9    | CAPSCREW,3/8" X 1-3/4",NC           |
| 32   | 6T7031D  | 4    | PLOW BOLT,1/2" X 1-1/2",NC          |
| 33   | 6T2330   | 8    | CAPSCREW,7/16" X 1-1/2",NC,SCKT HD  |
| 34   | 6T1023R  | 2    | NYLOCK NUT,1-1/8",NF                |
| 35   | TF1032   | 1    | FLANGE BEARING GREASE HOSE          |
| 36   | 31204    | 2    | STRING GUARD SET (2 PIECES PER SET) |

# 63IN FLAIL DRIVE ASSEMBLY

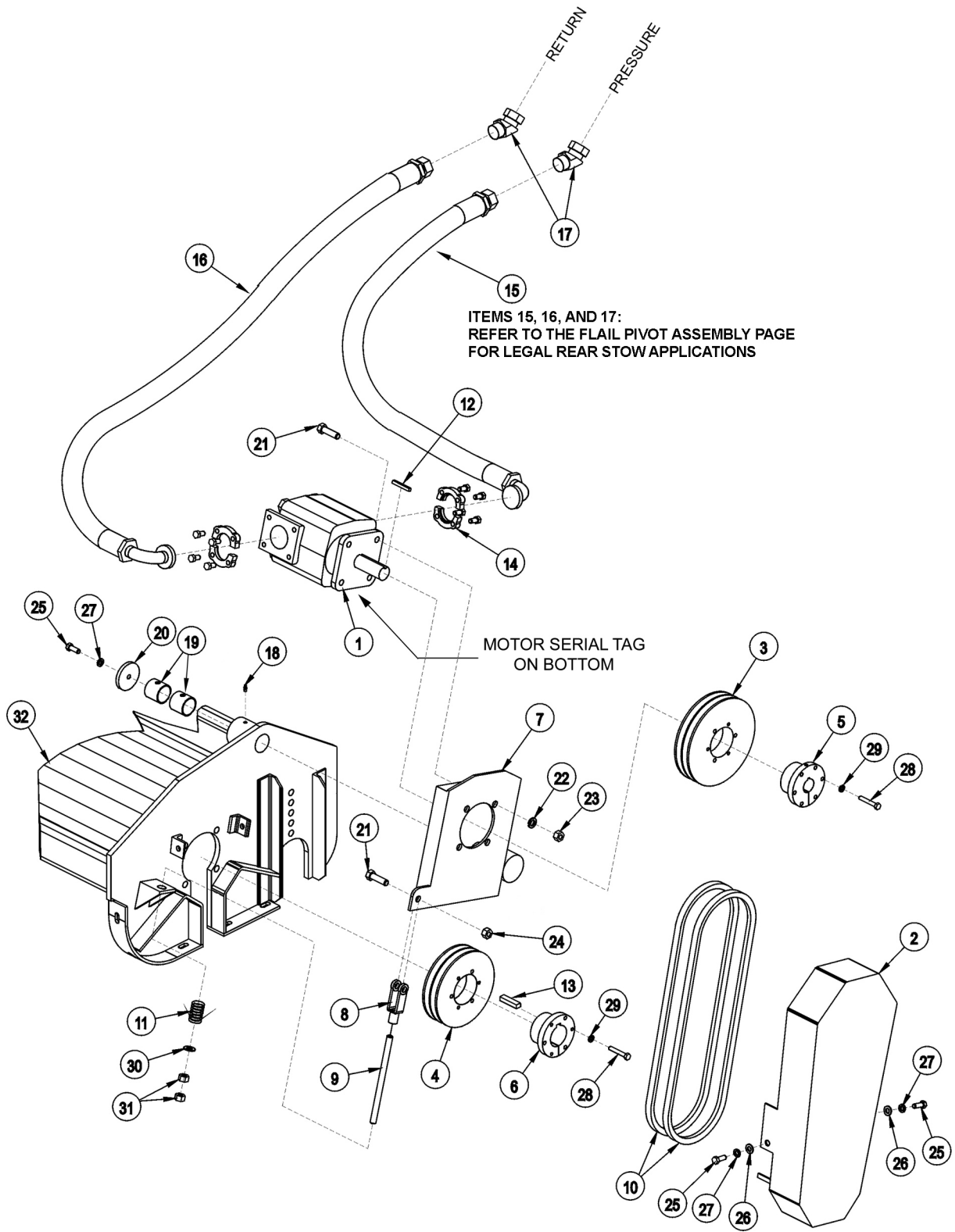



## 63IN FLAIL DRIVE ASSEMBLY

Continued...

| ITEM | PART NO. | QTY. | DESCRIPTION                      |
|------|----------|------|----------------------------------|
| 1    | 06504132 | 1    | MOTOR (M350-1 3/4 GEAR)          |
| 2    | 32569    | 1    | BELT GUARD                       |
| 3    | TF3044   | 1    | UPPER SHEAVE                     |
| 4    | TF3040   | 1    | LOWER SHEAVE                     |
| 5    | TF3013   | 1    | BUSHING                          |
| 6    | 28723    | 1    | BUSHING                          |
| 7    | 28679B   | 1    | MOTOR CHANNEL                    |
| 8    | PT3611A  | 1    | CLEVIS                           |
| 9    | 40496    | 1    | THREADED ROD                     |
| 10   | 28702    | 2    | BELT                             |
| 11   | TF3620A  | 1    | TENSIONER SPRING                 |
| 12   | 28572    | 1    | SQUARE KEY                       |
| 13   | 26142A   | 1    | SQUARE KEY                       |
| 14   | TF4852   | 2    | FLANGE KIT                       |
| 15   | 30308    | 1    | HOSE,1 X 69 - PRESSURE           |
| 16   | 30309    | 1    | HOSE,1 X 78 - RETURN             |
| 17   | 24724    | 2    | SWIVEL FITTING                   |
| 18   | TF1033   | 1    | GREASE ZERK                      |
| 19   | 27580    | 2    | BUSHING                          |
| 20   | 28682    | 1    | MOTOR CHANNEL WASHER             |
| 21   | 21732    | 5    | CAPSCREW 1/2" X 1 3/4"           |
| 22   | 21990    | 4    | LOCKWASHER 1/2"                  |
| 23   | 21725    | 4    | HEX NUT 1/2"                     |
| 24   | 6T2418   | 1    | STOVER NUT 1/2"                  |
| 25   | 21630    | 3    | CAPSCREW 3/8" X 1"               |
| 26   | 22016    | 2    | FLATWASHER 3/8"                  |
| 27   | 21988    | 3    | LOCKWASHER 3/8"                  |
| 28   | 21584    | 6    | CAPSCREW 5/16" X 2"              |
| 29   | 21987    | 6    | LOCKWASHER 5/16"                 |
| 30   | 27938    | 1    | FLATWASHER 1/2"                  |
| 31   | 21700    | 2    | HEX NUT 1/2" NF                  |
| 32   | -----    | -    | CUTTER HEAD *REFER TO MOWER ASSY |

# 63IN FLAIL MOWER ASSEMBLY

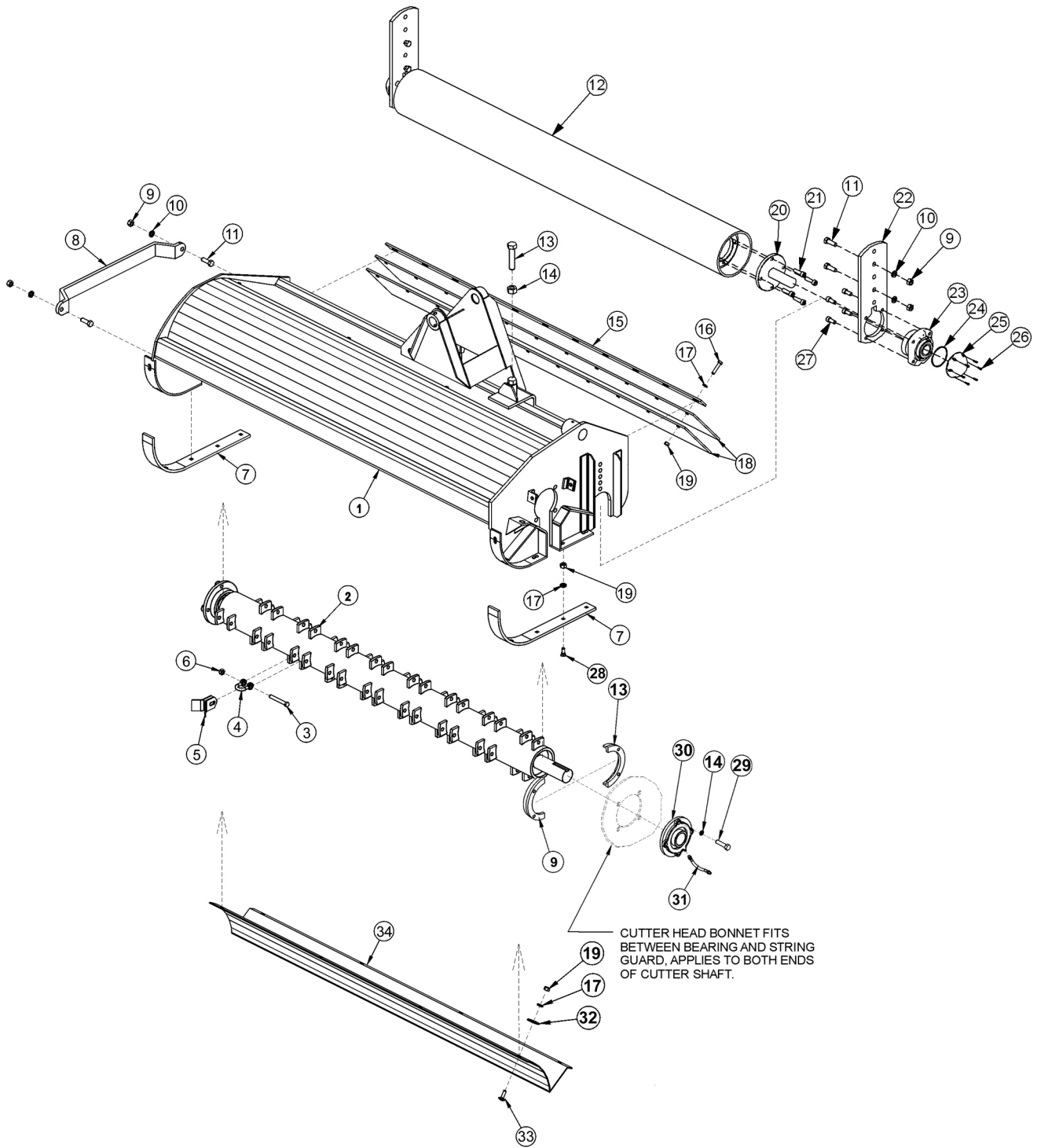

CUTTER HEAD BONNET FITS BETWEEN BEARING AND STRING GUARD, APPLIES TO BOTH ENDS OF CUTTER SHAFT.

## 63IN FLAIL MOWER ASSEMBLY

Continued...

| ITEM  | PART NO. | QTY. | DESCRIPTION                               |
|-------|----------|------|-------------------------------------------|
| ----- | 06200271 | -    | FLAIL,BOOM,63,GRASS,CPLT ASSY             |
| 1     | 28659H   | 1    | CUTTER HEAD BONNET                        |
| 2     | 28743    | -    | CUTTER SHAFT / KNIFE ASSY STANDARD GRASS  |
| ----- | 28642C   | 1    | CUTTER SHAFT,63,STD                       |
| 3     | 34011    | 36   | FLAIL KNIFE MOUNTING BOLT                 |
| 4     | TF1020   | 36   | FLAIL KNIFE MOUNTING CLEVIS               |
| 5     | 33713    | 72   | FLAIL KNIFE - STANDARD                    |
| 6     | 21677    | 36   | NYLOCK NUT                                |
| 7     | 28086A   | 2    | SKID SHOE                                 |
| 8     | 27975A   | 1    | CUTTER SHAFT GUARD                        |
| 9     | 21725    | 14   | HEX NUT 1/2"                              |
| 10    | 21990    | 14   | LOCKWASHER 1/2"                           |
| 11    | 21731    | 6    | CAPSCREW 1/2" X 1 1/2"                    |
| 12    | 28650A   | 1    | GROUND ROLLER                             |
| 13    | 33863    | 2    | STRING GUARD,STD                          |
| 14    | 06533006 | 8    | FLATWASHER,1/2",SAE,L9                    |
| 15    | 28700    | 1    | FLAP RETAINING BAR                        |
| 16    | 21633    | 11   | CAPSCREW 3/8" X 1 3/4"                    |
| 17    | 21988    | 28   | LOCKWASHER 3/8"                           |
| 18    | 28701    | 2    | DEFLECTOR FLAP                            |
| 19    | 21625    | 28   | HEX NUT 3/8"                              |
| 20    | TF1045B  | 2    | GROUND ROLLER STUB SHAFT                  |
| 21    | 6T2330   | 8    | CAPSCREW 7/16" X 1 1/2" SOCKET HEAD       |
| 22    | 28735    | 2    | ADJUSTABLE ROLLER BRACKET                 |
| 23    | 06520028 | 2    | BEARING,FLANGE,1-3/8,GRNDRLLR             |
| 24    | 06520029 | 2    | O-RING                                    |
| 25    | 06520027 | 2    | CAP,BEARING,GROUNDROLLER                  |
| 26    | 06530001 | 12   | CAPSCREW,SKT HD,8-32 X 1/2,SS             |
| 27    | 6T2331   | 8    | CAPSCREW 7/16" X 1" SOCKET HEAD           |
| 28    | 6T2270   | 10   | PLOW BOLT 3/8" X 1 1/4"                   |
| 29    | 06530217 | 8    | CAPSCREW 1/2" X 2",L9                     |
| 30    | 28683    | 2    | FLANGE BEARING                            |
| 31    | TF1032   | 1    | FLANGE BEARING GREASE HOSE                |
| 32    | 6T2615   | 7    | FENDER WASHER 3/8"                        |
| 33    | 6T2283   | 7    | CARRIAGE BOLT 3/8" X 1"                   |
| 34    | 28665A   | 1    | BAFFLE (INSIDE UPPER REAR OF CUTTER HEAD) |

# BOOM FLAIL PIVOT ASSEMBLY

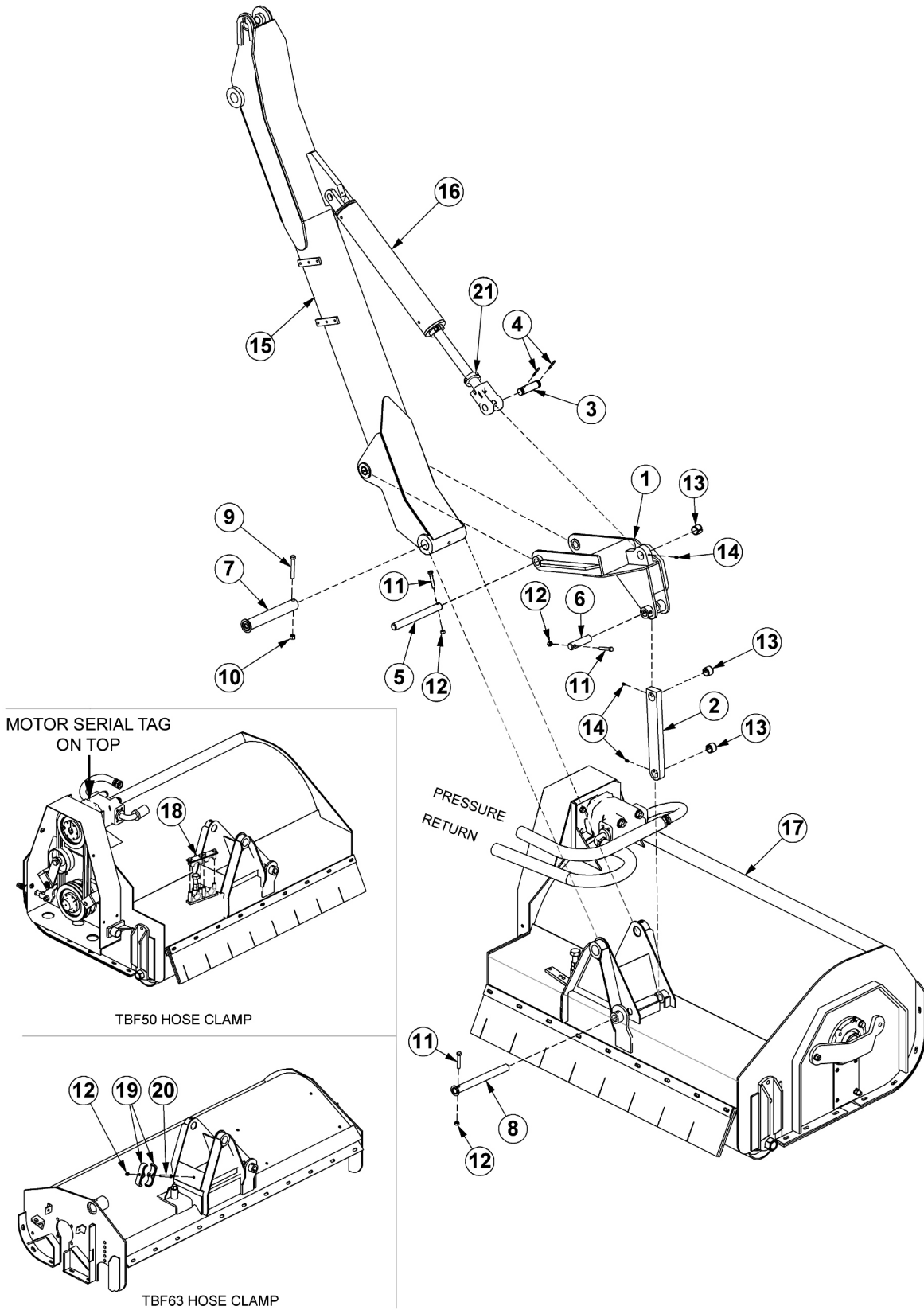

## BOOM FLAIL PIVOT ASSEMBLY

Continued...

| ITEM | PART NO. | QTY. | DESCRIPTION                               |
|------|----------|------|-------------------------------------------|
| 1    | TF3015   | 1    | FLAIL PIVOT ASSY                          |
| 2    | TB1028   | 1    | PIVOT ARM ASSY                            |
| 3    | TB1033   | 1    | PIN CLEVIS                                |
| 4    | 06537021 | 2    | ROLL PIN                                  |
| 5    | TF3097   | 1    | PIN                                       |
| 6    | TF3090   | 1    | PIN                                       |
| 7    | TB1024   | 1    | PIN                                       |
| 8    | TB1027   | 1    | PIN                                       |
| 9    | 21688    | 1    | CAPSCREW 7/16" X 3 1/4"                   |
| 10   | 21677    | 1    | NYLOCK NUT 7/16"                          |
| 11   | 21635    | 3    | CAPSCREW 3/8" X 2 1/4"                    |
| 12   | 21627    | 4    | NYLOCK NUT 3/8"                           |
| 13   | TB1030   | 3    | BUSHING                                   |
| 14   | 6T3207   | 3    | GREASE ZERK                               |
| 15   | -----    | -    | SECONDARY BOOM *REFER TO BOOM ARM ASSY    |
| 16   | -----    | -    | CYLINDER - REFER TO BOOM ARM ASSY         |
| 17   | -----    | -    | FLAIL MOWER HEAD *REFER TO FLAIL ASSY     |
| 18   | 31723    | 1    | CLAMP KIT,TBF50 (USED ON 50" FLAIL)       |
| 19   | TB3031   | 2    | DOUBLE HOSE CLAMP (USED ON THE 63" FLAIL) |
| 20   | 21638    | 1    | CAPSCREW 3/8" X 3"                        |
| 21   | 35312    | 2    | SPLIT COLLAR                              |

## 3IN X 13-7/8 IN WELDED CYLINDER BREAKDOWN

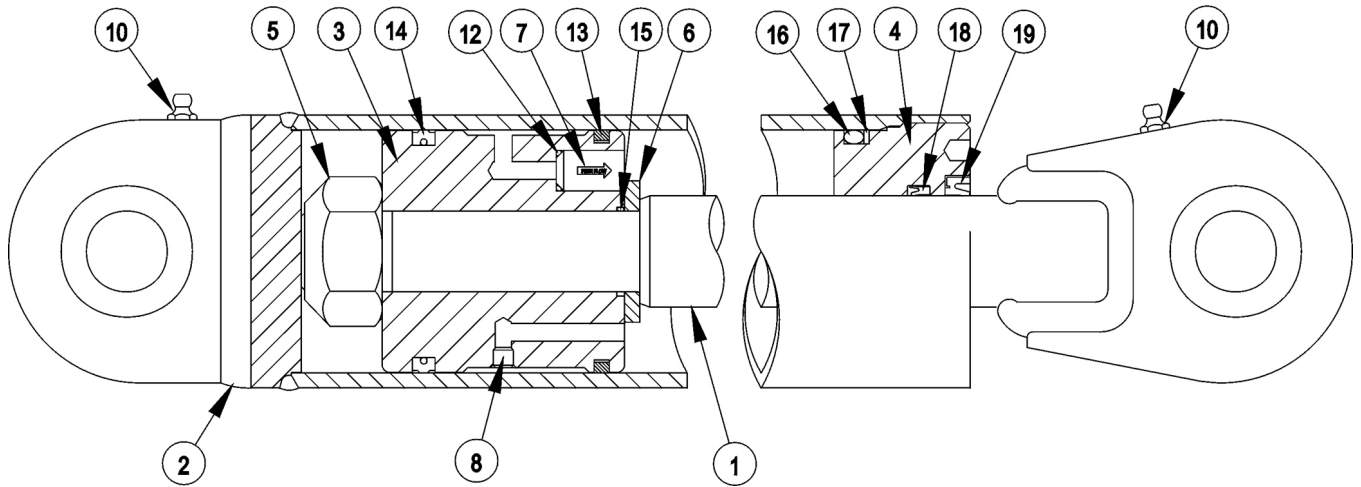

**WARNING** - MECHANICAL FASTENERS MUST BE TORQUED TO RECOMMENDED SPECIFICATIONS DURING REPAIR TO PREVENT PERSONAL INJURY OR EQUIPMENT DAMAGE.

| ITEM | PART NO. | QTY. | DESCRIPTION                               |
|------|----------|------|-------------------------------------------|
| ---  | 06501029 | -    | CYLINDER,WELDED,3" X 13.87"               |
| 1    | 06501630 | 1    | PISTON ROD ASSY                           |
| 2    | 06501631 | 1    | BUTT & TUBE ASSY                          |
| 3    | 06501632 | 1    | PISTON                                    |
| 4    | 34574    | 1    | GLAND                                     |
| 5    | 34575    | 1    | LOCK NUT,1"-14 UNS (TORQUE TO 315 FT.LB.) |
| 6    | 34576    | 1    | SPACER                                    |
| 7    | 34577    | 1    | CHECK VALVE,KEPNER                        |
| 8    | 06501633 | 1    | ORIFICE                                   |
| 9    | 33761    | 1    | SEAL KIT,PACKING (ITEMS 12 THRU 19)       |
| 10   | -----    | 2    | GREASE ZERK                               |
| 12   | -----    | 1    | O - RING                                  |
| 13   | -----    | 1    | CAST IRON PISTON RING                     |
| 14   | -----    | 1    | CROWN SEAL                                |
| 15   | -----    | 1    | O - RING                                  |
| 16   | -----    | 1    | O - RING                                  |
| 17   | -----    | 1    | BACK - UP WASHER                          |
| 18   | -----    | 1    | U - CUP                                   |
| 19   | -----    | 1    | WIPER                                     |
| 20   | 34334    | -    | SPHERICAL BEARING (NOT SHOWN)             |

## 3IN X 18IN WELDED CYLINDER BREAKDOWN

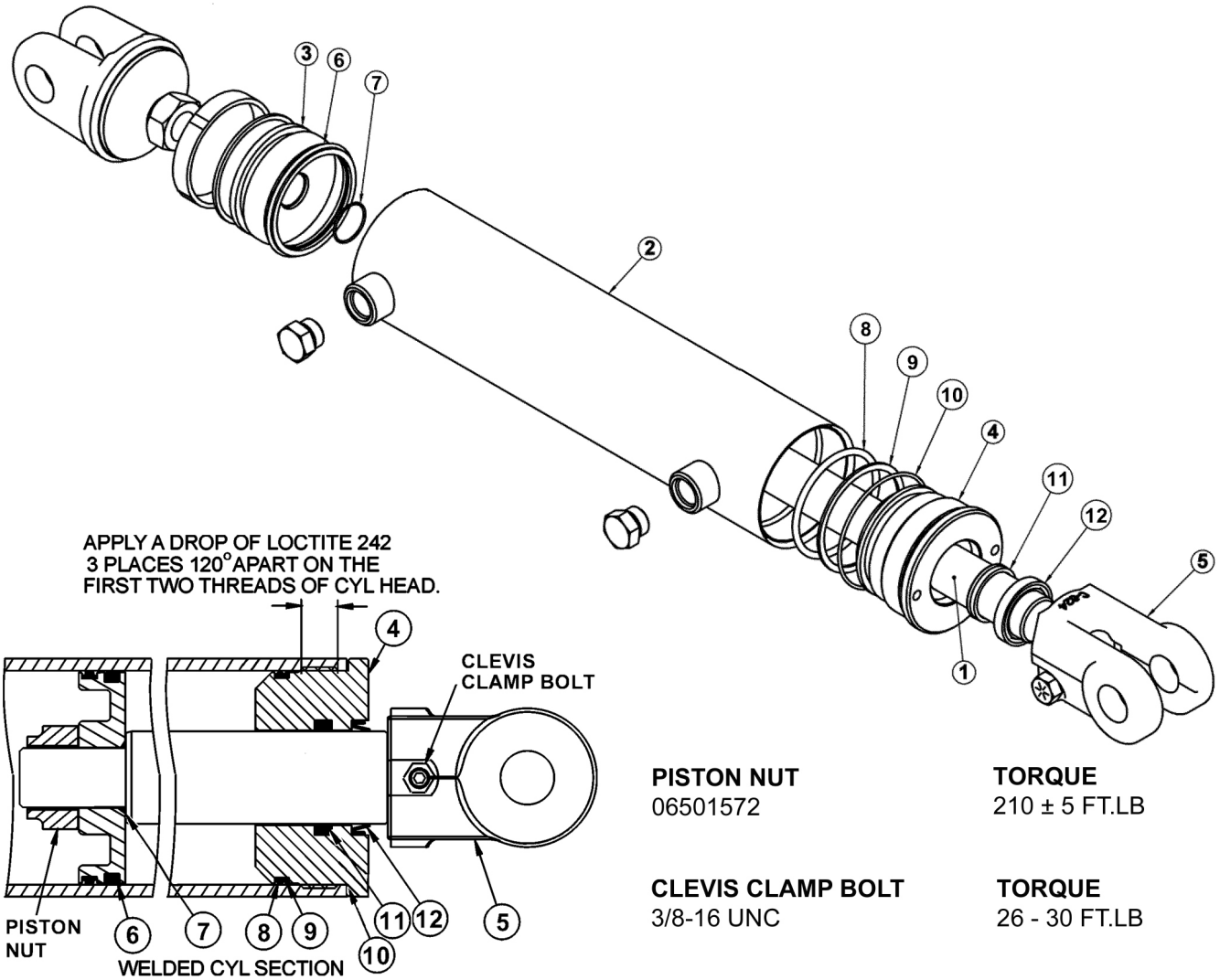

**WARNING - MECHANICAL FASTENERS MUST BE TORQUED TO RECOMMENDED SPECIFICATIONS DURING REPAIR TO PREVENT PERSONAL INJURY OR EQUIPMENT DAMAGE.**

| ITEM  | PART NO. | QTY. | DESCRIPTION                          |
|-------|----------|------|--------------------------------------|
| ----- | 06501023 | -    | HYDRAULIC CYLINDER COMPLETE          |
| 1     | 06501561 | 1    | ROD                                  |
| 2     | 06501562 | 1    | TUBE WELDMENT                        |
| 3     | 06501552 | 1    | PISTON                               |
| 4     | 06501563 | 1    | CYLINDER HEAD                        |
| 5     | 06501554 | 1    | CLEVIS                               |
| ----- | 06501564 | -    | SEAL REPAIR KIT (ITEMS 6 THROUGH 12) |

## 3-1/2IN X 20IN WELDED CYLINDER BREAKDOWN

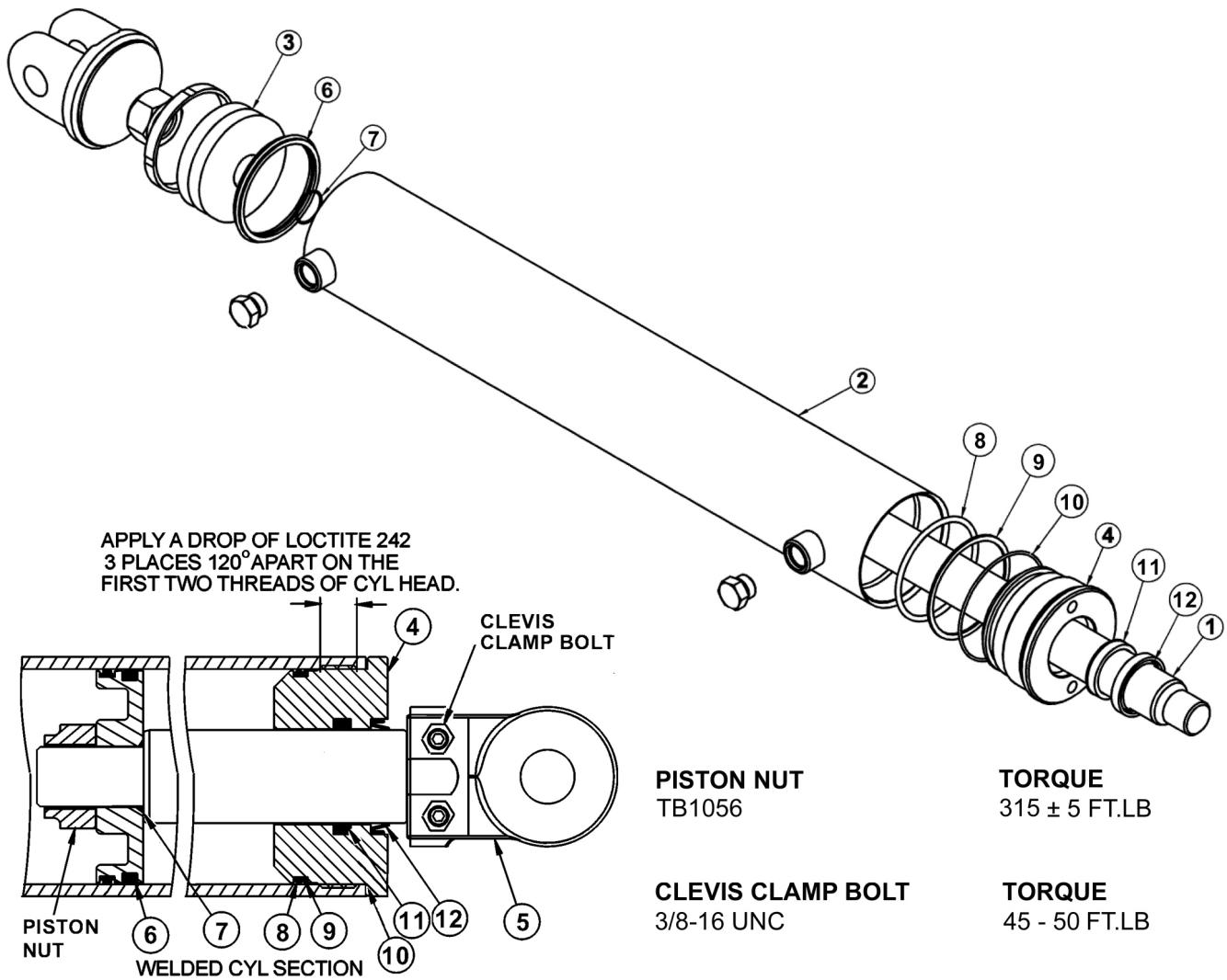

**WARNING - MECHANICAL FASTENERS MUST BE TORQUED TO RECOMMENDED SPECIFICATIONS DURING REPAIR TO PREVENT PERSONAL INJURY OR EQUIPMENT DAMAGE.**

| ITEM  | PART NO. | QTY. | DESCRIPTION                          |
|-------|----------|------|--------------------------------------|
| ----- | 06501024 | -    | HYDRAULIC CYLINDER COMPLETE          |
| 1     | 06501565 | 1    | ROD                                  |
| 2     | 06501566 | 1    | TUBE WELDMENT                        |
| 3     | 06501567 | 1    | PISTON                               |
| 4     | 06501568 | 1    | CYLINDER HEAD                        |
| 5     | TB3033   | -    | CLEVIS                               |
| ----- | 06501569 | -    | SEAL REPAIR KIT (ITEMS 6 THROUGH 12) |



## 4IN X 20IN WELDED CYLINDER BREAKDOWN

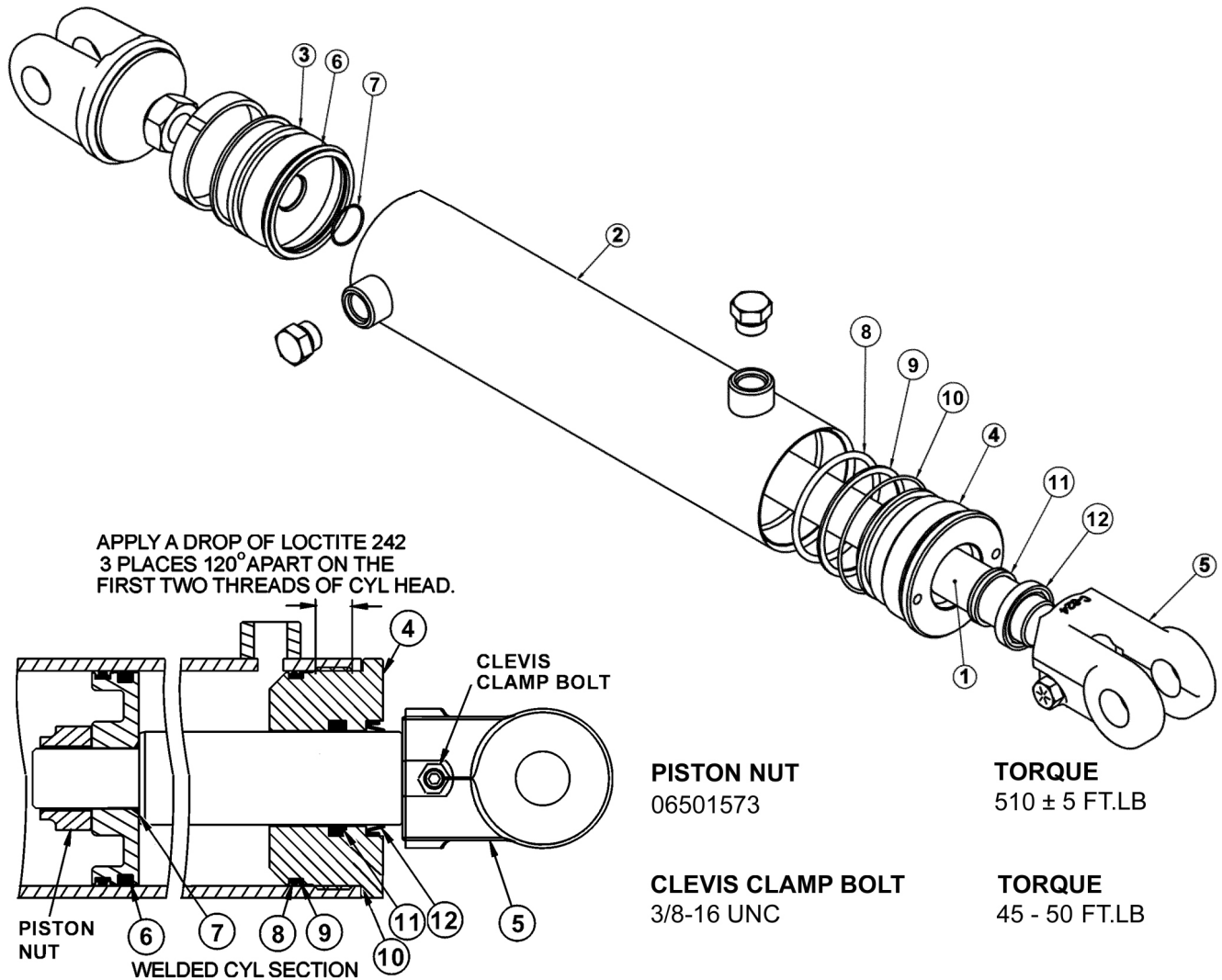

**WARNING - MECHANICAL FASTENERS MUST BE TORQUED TO RECOMMENDED SPECIFICATIONS DURING REPAIR TO PREVENT PERSONAL INJURY OR EQUIPMENT DAMAGE.**

| ITEM  | PART NO. | QTY. | DESCRIPTION                          |
|-------|----------|------|--------------------------------------|
| ----- | 06501022 | -    | HYDRAULIC CYLINDER COMPLETE          |
| 1     | 06501556 | 1    | ROD                                  |
| 2     | 06501557 | 1    | TUBE WELDMENT                        |
| 3     | 06501558 | 1    | PISTON                               |
| 4     | 06501559 | 1    | CYLINDER HEAD                        |
| 5     | 6T0172   | 1    | CLEVIS                               |
| 5A    | 30172    | -    | CLEVIS (FOR EXTENDED BOOM)           |
| ----- | 06501560 | -    | SEAL REPAIR KIT (ITEMS 6 THROUGH 12) |

## 5IN X 20IN WELDED CYLINDER BREAKDOWN

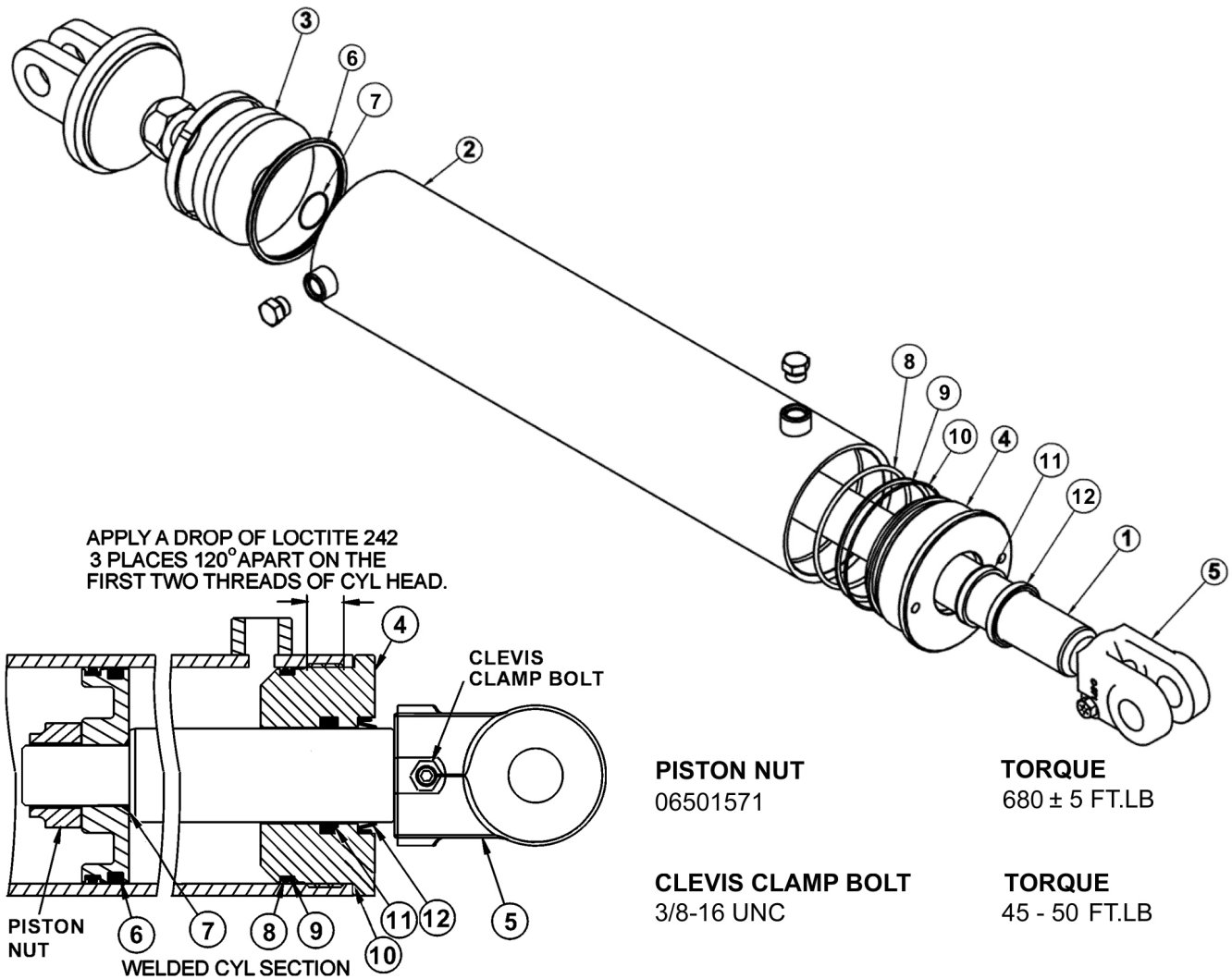

**WARNING - MECHANICAL FASTENERS MUST BE TORQUED TO RECOMMENDED SPECIFICATIONS DURING REPAIR TO PREVENT PERSONAL INJURY OR EQUIPMENT DAMAGE.**

| ITEM  | PART NO. | QTY. | DESCRIPTION                          |
|-------|----------|------|--------------------------------------|
| ----- | 06501020 | -    | HYDRAULIC CYLINDER COMPLETE          |
| 1     | 06501544 | 1    | ROD                                  |
| 2     | 06501545 | 1    | TUBE WELDMENT                        |
| 3     | 06501546 | 1    | PISTON                               |
| 4     | 06501547 | 1    | CYLINDER HEAD                        |
| 5     | 06501548 | 1    | CLEVIS                               |
| ----- | 06501549 | -    | SEAL REPAIR KIT (ITEMS 6 THROUGH 12) |

**NOTES**

**NOTES**

## 5 SPOOL ELECTRONIC VALVE - OPEN STOW,3PS

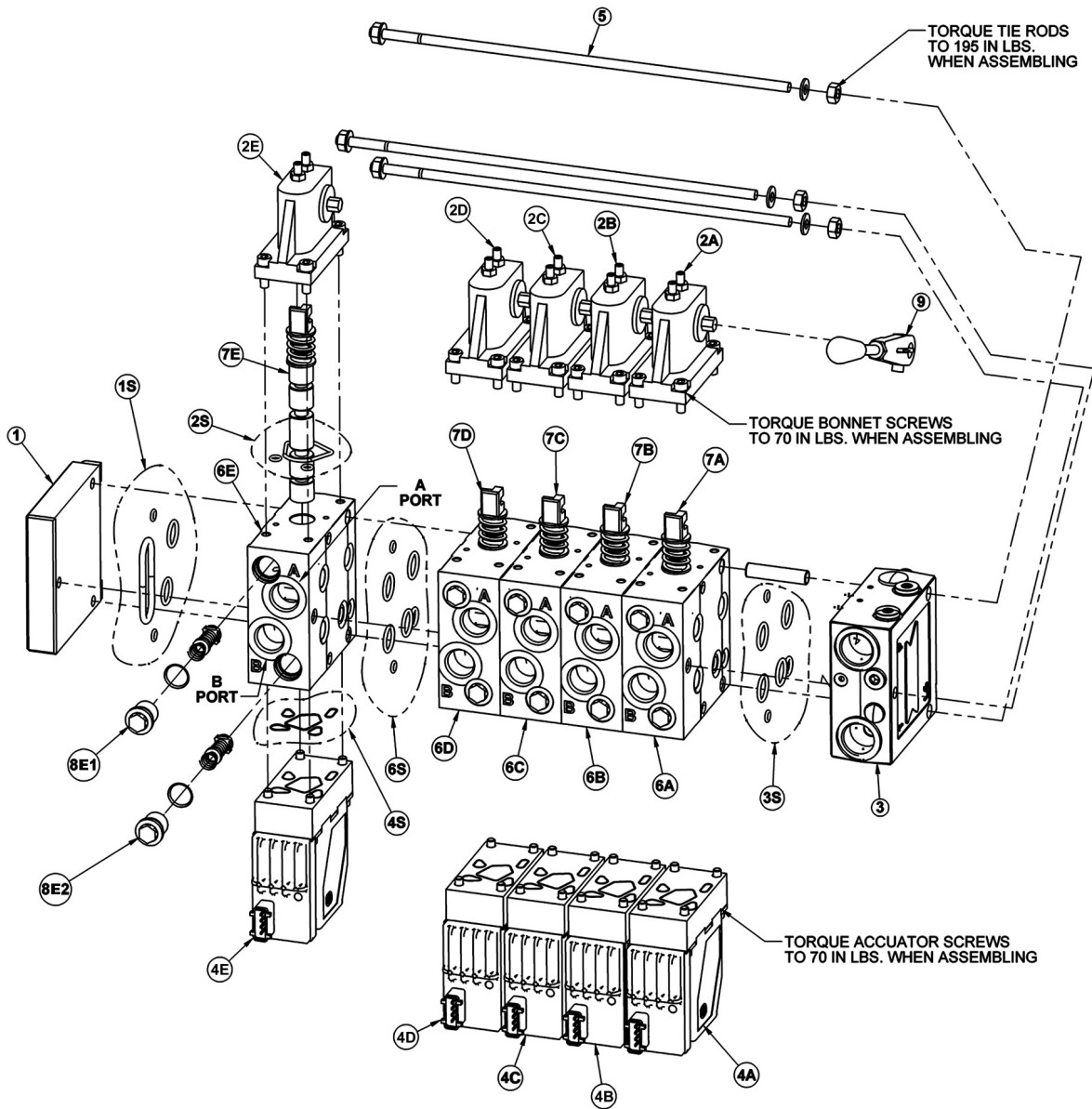

| ITEM  | PART NO. | QTY. | DESCRIPTION                  |
|-------|----------|------|------------------------------|
| ----- | 06502097 | -    | VLV,5SP,32PVG,OPEN STOW, 3OS |
| 1     | 06502074 | 1    | END PLATE                    |
| 1S    | 06505013 | 1    | END PLATE SEAL KIT           |
| 2     | -----    | 5    | BONNET                       |
| 2S    | 06505042 | 1    | BONNET SEAL KIT              |
| 2A    | 42197    | 1    | MAIN BOOM BONNET             |
| 2B    | 42197    | 1    | SECONDARY BOOM BONNET        |
| 2C    | 42197    | 1    | DECK ROLL BONNET             |
| 2D    | 42197    | 1    | BOOM SWIVEL BONNET           |
| 2E    | 42197    | 1    | DECK SHIELD BONNET           |

## 5 SPOOL ELECTRONIC VALVE - OPEN STOW,3PS

Continued...

| ITEM | PART NO. | QTY. | DESCRIPTION                        |
|------|----------|------|------------------------------------|
| 3    | 34308    | 1    | INLET SECTION                      |
| 3S   | 06505013 | 1    | INLET SECTION SEAL KIT             |
| 4    | -----    | 5    | ELECTRONIC ACCUATOR                |
| 4A   | 06502101 | 1    | MAIN BOOM ELECTRONIC ACCUATOR      |
| 4B   | 06502101 | 1    | SECONDARY BOOM ELECTRONIC ACCUATOR |
| 4C   | 06502100 | 1    | DECK ROLL ELECTRONIC ACCUATOR      |
| 4D   | 06502101 | 1    | BOOM SWIVEL ELECTRONIC ACCUATOR    |
| 4E   | 06502099 | 1    | DECK SHIELD ELECTRONIC ACCUATOR    |
| 5    | 42202    | 1    | TIE-BOLT KIT                       |
| 6    | -----    | 5    | SECTION                            |
| 6S   | 06505013 | 1    | SECTION SEAL KIT                   |
| 6A   | 42698    | 1    | MAIN BOOM SECTION                  |
| 6B   | 42698    | 1    | SEC BOOM SECTION                   |
| 6C   | 06502076 | 1    | DECK ROLL SECTION                  |
| 6D   | 42698    | 1    | BOOM SWIVEL SECTION                |
| 6E   | 06502077 | 1    | SHIELD SECTION                     |
| 7    | -----    | 5    | SPOOL                              |
| 7A   | 42697    | 1    | MAIN BOOM SPOOL                    |
| 7B   | 42697    | 1    | SEC BOOM SPOOL                     |
| 7C   | 4242106  | 1    | DECK ROLL SPOOL                    |
| 7D   | 06502073 | 1    | BOOM SWIVEL SPOOL                  |
| 7E   | 42201    | 1    | DECK SHIELD SPOOL                  |
| 8    | -----    | 10   | ANTI CAV/SHOCK RELIEF              |
| 8A1  | 06502084 | 1    | MAIN BOOM A PORT RELIEF            |
| 8A2  | 06502081 | 1    | MAIN BOOM B PORT RELIEF            |
| 8B1  | 42296    | 1    | SEC BOOM A PORT RELIEF             |
| 8B2  | 06502082 | 1    | SEC BOOM B PORT RELIEF             |
| 8C1  | 42295    | 1    | DECK ROLL A PORT RELIEF            |
| 8C2  | 06502082 | 1    | DECK ROLL B PORT RELIEF            |
| 8D1  | 06502070 | 1    | BOOM SWIVEL A PORT RELIEF          |
| 8D2  | 06502083 | 1    | BOOM SWIVEL B PORT RELIEF          |
| 8E1  | 06502081 | 1    | DECK SHIELD A PORT RELIEF          |
| 8E2  | 06502081 | 1    | DECK SHIELD B PORT RELIEF          |
| 9    | 33459    | 1    | HANDLE                             |

COMMON BENGAL T4

## 5 SPOOL ELECTRONIC VALVE - SIDE STOW

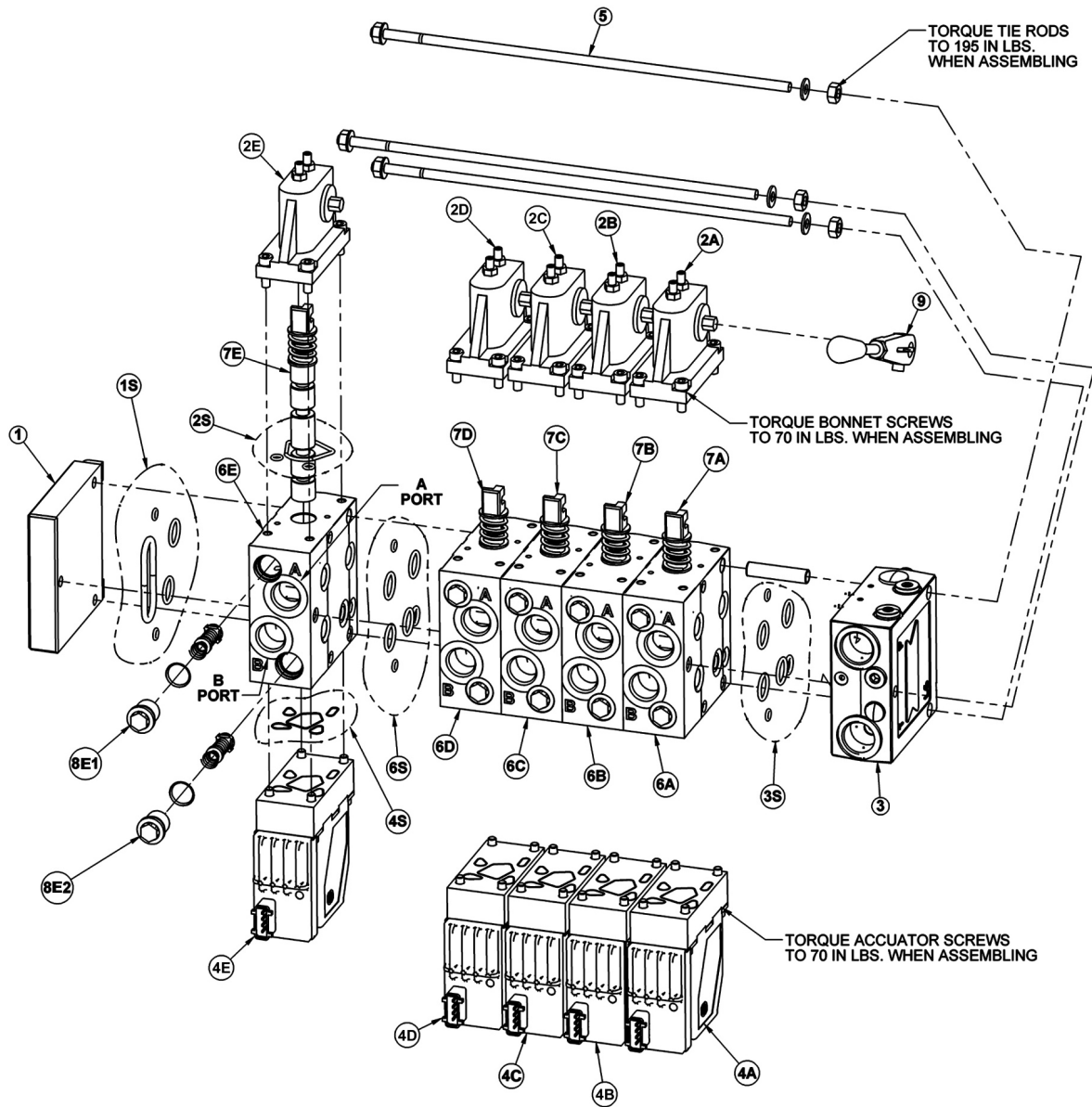

| ITEM  | PART NO. | QTY. | DESCRIPTION             |
|-------|----------|------|-------------------------|
| ----- | 06502096 | -    | VLV,5SP,32PVG,SIDE STOW |
| 1     | 06502074 | 1    | END PLATE               |
| 1S    | 06505013 | 1    | END PLATE SEAL KIT      |
| 2     | -----    | 5    | BONNET                  |
| 2S    | 06505042 | 1    | BONNET SEAL KIT         |
| 2A    | 42197    | 1    | MAIN BOOM BONNET        |
| 2B    | 42197    | 1    | SECONDARY BOOM BONNET   |
| 2C    | 42197    | 1    | DECK ROLL BONNET        |
| 2D    | 42197    | 1    | BOOM SWIVEL BONNET      |
| 2E    | 42197    | 1    | DECK SHIELD BONNET      |

## 5 SPOOL ELECTRONIC VALVE - SIDE STOW

Continued...

| ITEM | PART NO. | QTY. | DESCRIPTION                        |
|------|----------|------|------------------------------------|
| 3    | 34308    | 1    | INLET SECTION                      |
| 3S   | 06505013 | 1    | INLET SECTION SEAL KIT             |
| 4    | -----    | 5    | ELECTRONIC ACCUATOR                |
| 4A   | 06502101 | 1    | MAIN BOOM ELECTRONIC ACCUATOR      |
| 4B   | 06502101 | 1    | SECONDARY BOOM ELECTRONIC ACCUATOR |
| 4C   | 06502100 | 1    | DECK ROLL ELECTRONIC ACCUATOR      |
| 4D   | 06502101 | 1    | BOOM SWIVEL ELECTRONIC ACCUATOR    |
| 4E   | 06502099 | 1    | DECK SHIELD ELECTRONIC ACCUATOR    |
| 5    | 42202    | 1    | TIE-BOLT KIT                       |
| 6    | -----    | 5    | SECTION                            |
| 6S   | 06505013 | 1    | SECTION SEAL KIT                   |
| 6A   | 42698    | 1    | MAIN BOOM SECTION                  |
| 6B   | 42698    | 1    | SEC BOOM SECTION                   |
| 6C   | 06502076 | 1    | DECK ROLL SECTION                  |
| 6D   | 42698    | 1    | BOOM SWIVEL SECTION                |
| 6E   | 06502077 | 1    | SHIELD SECTION                     |
| 7    | -----    | 5    | SPOOL                              |
| 7A   | 42697    | 1    | MAIN BOOM SPOOL                    |
| 7B   | 42697    | 1    | SEC BOOM SPOOL                     |
| 7C   | 4242106  | 1    | DECK ROLL SPOOL                    |
| 7D   | 06502073 | 1    | BOOM SWIVEL SPOOL                  |
| 7E   | 42201    | 1    | DECK SHIELD SPOOL                  |
| 8    | -----    | 10   | ANTI CAV/SHOCK RELIEF              |
| 8A1  | 42650    | 1    | MAIN BOOM A PORT RELIEF            |
| 8A2  | 06502069 | 1    | MAIN BOOM B PORT RELIEF            |
| 8B1  | 42650    | 1    | SEC BOOM A PORT RELIEF             |
| 8B2  | 42295    | 1    | SEC BOOM B PORT RELIEF             |
| 8C1  | 42296    | 1    | DECK ROLL A PORT RELIEF            |
| 8C2  | 42295    | 1    | DECK ROLL B PORT RELIEF            |
| 8D1  | 42295    | 1    | BOOM SWIVEL A PORT RELIEF          |
| 8D2  | 42295    | 1    | BOOM SWIVEL B PORT RELIEF          |
| 8E1  | 06502069 | 1    | DECK SHIELD A PORT RELIEF          |
| 8E2  | 06502069 | 1    | DECK SHIELD B PORT RELIEF          |
| 9    | 33459    | 1    | HANDLE                             |

# FRONT HYDRAULIC PUMP

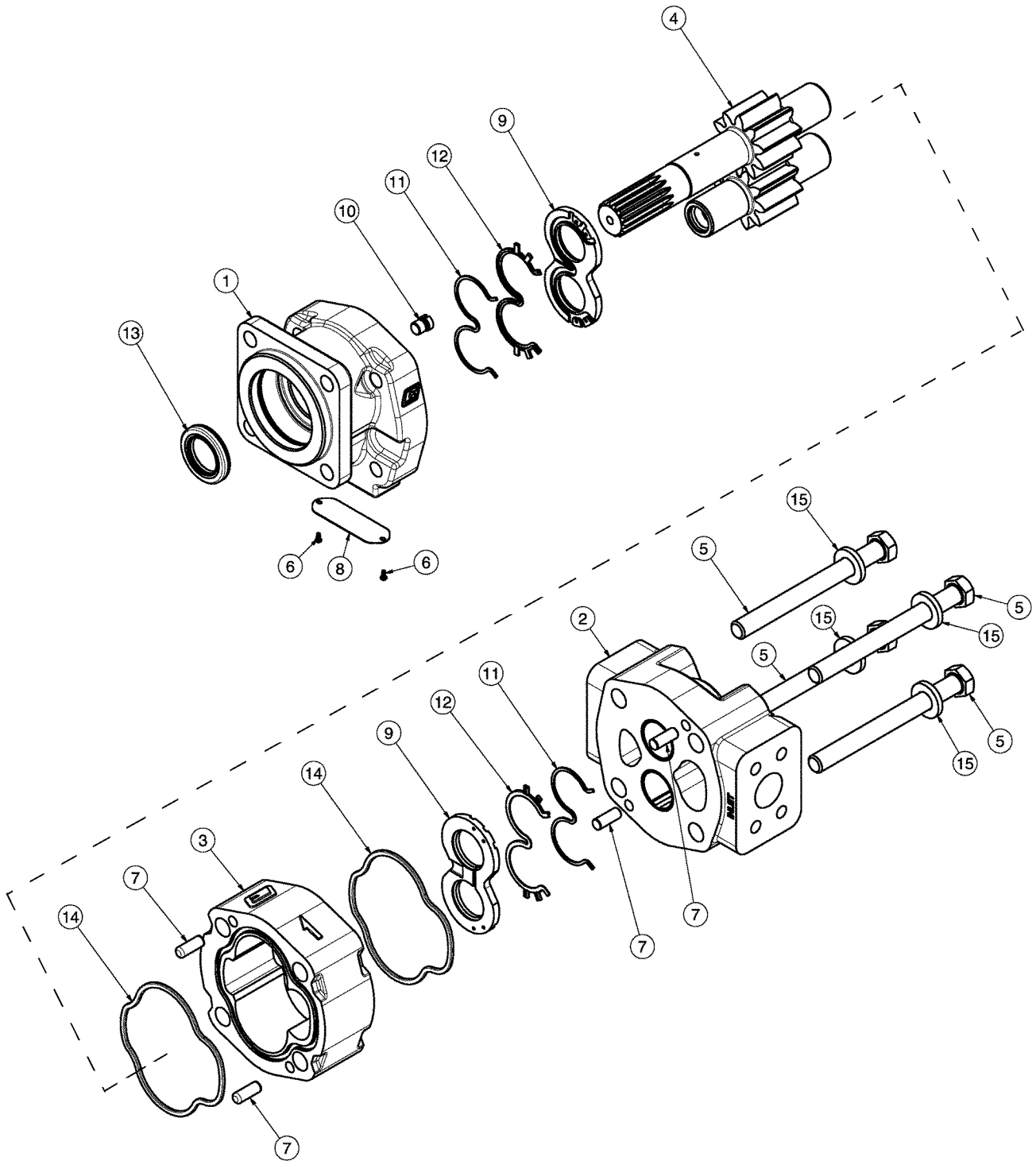



## FRONT HYDRAULIC PUMP

Continued...

| ITEM | PART NO. | QTY. | DESCRIPTION                           |
|------|----------|------|---------------------------------------|
| ---  | 23152    | 1    | PUMP ASSEMBLY,1-3/4",COMPLETE         |
| 1    | 22766    | 1    | SHAFT END COVER                       |
| 2    | 22779    | 1    | PORT END COVER                        |
| 3    | 22774    | 1    | GEAR HOUSING,1-3/4"                   |
| 4    | 22771    | 1    | GEAR SET                              |
| 5    | 23824    | 4    | CAPSCREW                              |
| 6    | 06504078 | 2    | SCREW,DRIVE                           |
| 7    | 22773    | 4    | DOWEL PINS                            |
| 8    | 06504077 | 1    | NAMEPLATE                             |
| 9    | 22770    | 2    | THRUST PLATE                          |
| 10   | 22767    | 1    | PLUG                                  |
| 11   | 06504075 | 2    | SEAL,BK-UP                            |
| 12   | 06504074 | 2    | SEAL,CHAN                             |
| 13   | 22765    | 1    | SEAL,LIP                              |
| 14   | 06504076 | 2    | SEAL,SQ-R                             |
| 15   | 02961917 | 4    | WASHER                                |
| ---  | 24150    | 1    | SEAL KIT (INCLUDES 11, 12, 13 AND 14) |

# 50IN AND 60IN ROTARY MOTOR BREAKDOWN

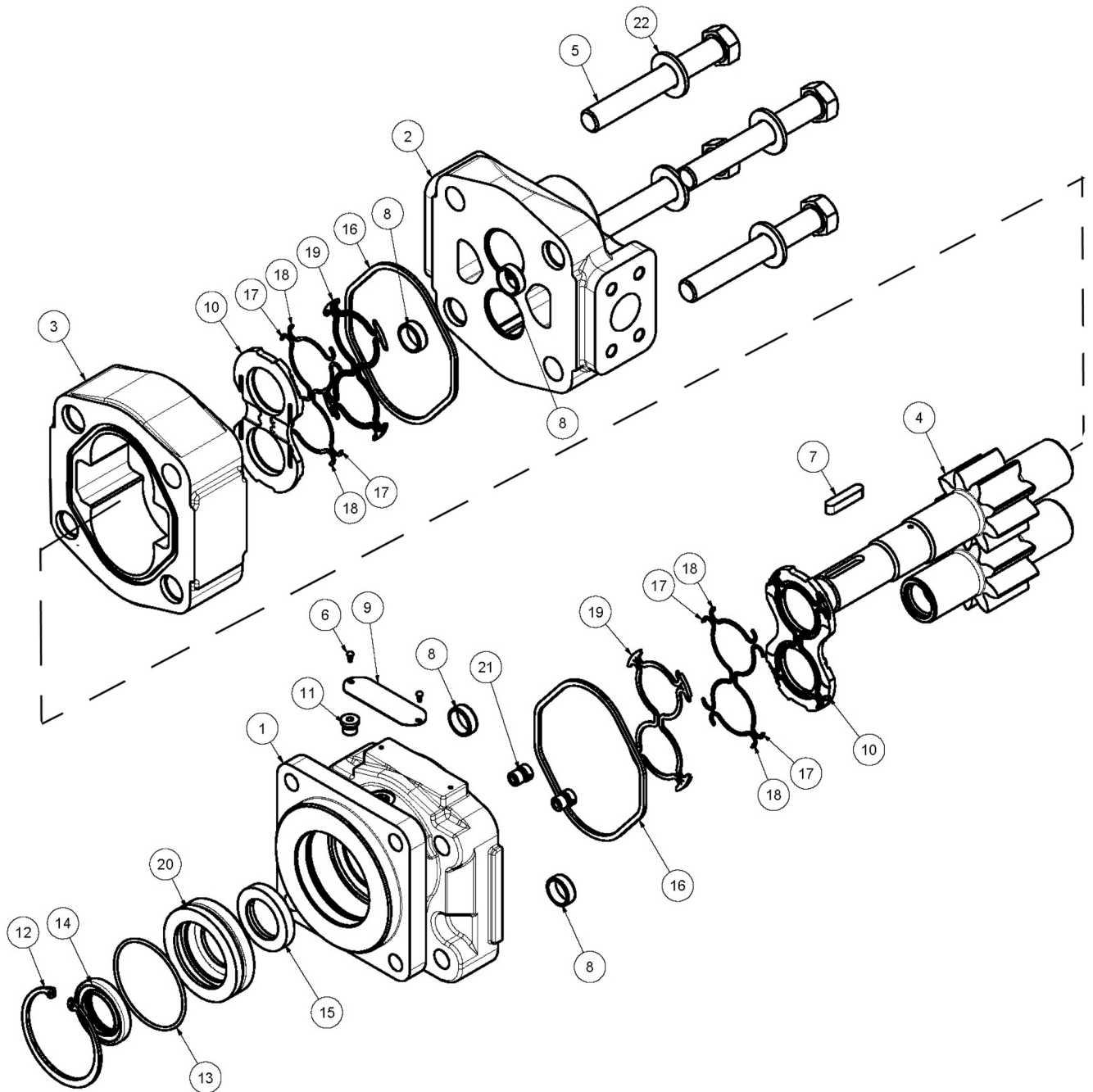

COMMON BENGAL T4

## 50IN AND 60IN ROTARY MOTOR BREAKDOWN

Continued...

| ITEM  | PART NO. | QTY. | DESCRIPTION          |
|-------|----------|------|----------------------|
|       | 06504011 | -    | MOTOR ASSEMBLY,TRB60 |
|       | 06504012 | -    | MOTOR ASSEMBLY,TRB50 |
| 1     | 22790    | 1    | HOUSING, SEC         |
| 2     | 06504088 | 1    | HOUSING, PEC         |
| 3     | 06504062 | 1    | HOUSING, GEAR,TRB60  |
| ----- | 06504089 | -    | HOUSING, GEAR,TRB50  |
| 4     | 06504090 | 1    | SET, GEAR SHAFT      |
| 5     | 06504104 | 4    | CAP SCREW,TRB60      |
| ----- | 06504091 | -    | CAP SCREW,TRB50      |
| 6     | 06504078 | 2    | SCREW, DRIVE         |
| 7     | 06504092 | 1    | KEY                  |
| 8     | 06504093 | 4    | PIN, DOWEL           |
| 9     | 06504094 | 1    | NAME PLATE           |
| 10    | 06504095 | 2    | THRPL                |
| 11    | 2961940  | 1    | PLUG, ODT            |
| 12    | 2962200  | 1    | RING, SNAP           |
| 13    | 06504096 | 1    | O RING               |
| 14    | 6T5101   | 1    | SEAL, LIP            |
| 15    | 06504097 | 1    | SEAL, LIP            |
| 16    | 22797    | 2    | SEAL, SQ-R           |
| 17    | 06504098 | 4    | SEAL, SIDE CHAN      |
| 18    | 06504099 | 4    | SEAL, END CHAN       |
| 19    | 06504100 | 2    | SEAL, BK-UP          |
| 20    | 06504101 | 1    | RTNR, SEAL           |
| 21    | 6T5809   | 2    | CHECK ASS'Y          |
| 22    | 06504102 | 4    | WASHER               |
| ----- | 06504103 | -    | SEAL KIT             |

# FLAIL MOTOR BREAKDOWN

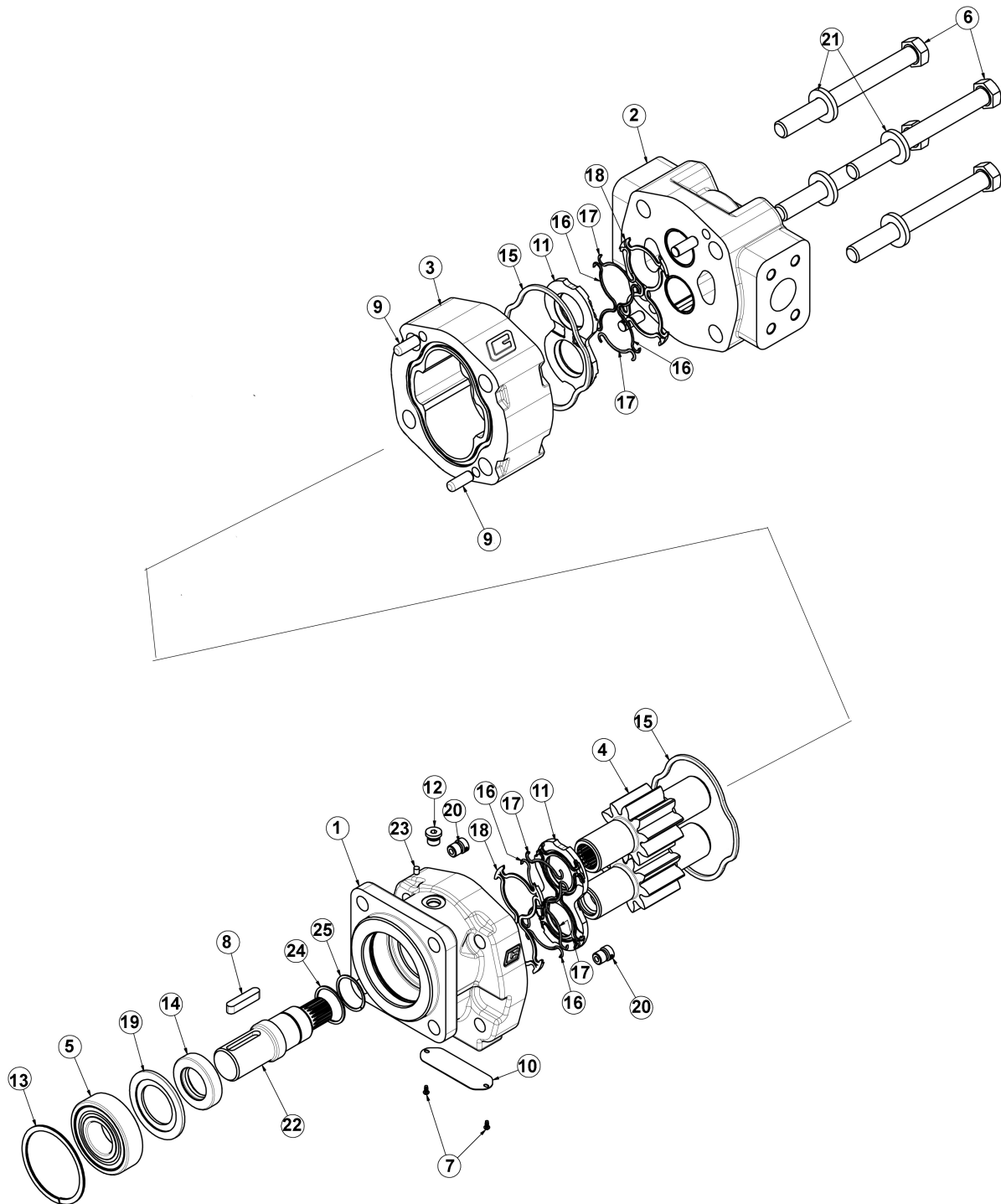

## FLAIL MOTOR BREAKDOWN

Continued...

| ITEM | PART NO. | QTY. | DESCRIPTION                       |
|------|----------|------|-----------------------------------|
| *    | 06504132 | -    | MOTOR ASSEMBLY 350 - TBF50, TBF63 |
| 1    | 06504141 | 1    | SHAFT END COVER                   |
| 2    | 06504040 | 1    | PORT END COVER                    |
| 3    | 06504041 | 1    | GEAR HOUSING                      |
| 4    | 06504117 | 1    | MATCHED GEAR SET                  |
| 5    | TF4402   | 1    | BALL BEARING                      |
| 6    | 06504043 | 4    | CAP SCREW                         |
| 7    | 06504044 | 2    | SET SCREW                         |
| 8    | 06504028 | 1    | KEY                               |
| 9    | 06504045 | 4    | DOWEL PIN                         |
| 10   | *        | 1    | NAMEPLATE                         |
| 11   | 763759   | 1    | THRUSTPLATE                       |
| 12   | 2961940  | 1    | PLUG, ODT (0.25)                  |
| 13   | TF4401   | 1    | SNAP RING                         |
| 14   | 06504142 | 1    | LIP SEAL                          |
| 15   | TF4410   | 2    | GASKET SEAL                       |
| 16   | 06504046 | 4    | SIDE SEAL                         |
| 17   | 06504047 | 4    | END SEAL                          |
| 18   | TF4407   | 2    | BACK-UP SEAL                      |
| 19   | 06504122 | 1    | SEAL RETAINER                     |
| 20   | 6T5809   | 2    | CHECK ASSEMBLY                    |
| 21   | 2961917  | 4    | WASHER                            |
| 22   | 06504140 | 1    | SHAFT                             |
| 23   | 06504139 | 1    | BREATHER                          |
| 24   | 06504121 | 1    | SPACER, BRG                       |
| 25   | 06504119 | 1    | SNAP RING                         |
| *    | 06504022 | -    | SEAL KIT                          |

## RESERVOIR TANK FILTER ASSEMBLY

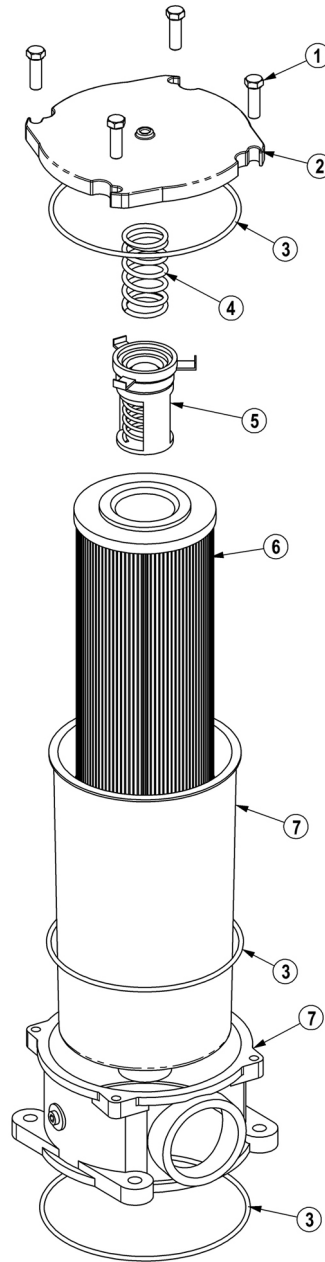

| ITEM  | PART NO. | QTY. | DESCRIPTION                     |
|-------|----------|------|---------------------------------|
| ----- | 06505044 | -    | FILTER ASSY SAE 10 MICRON       |
| 1     | 28583    | 4    | CAPSCREW,8MM X 25MM(1.25 PITCH) |
| 2     | 06505045 | 1    | COVER                           |
| 3     | 06505046 | 1    | SEAL KIT                        |
| 4     | 06505047 | 1    | SPRING                          |
| 5     | 06505048 | 1    | BYPASS                          |
| 6     | 35259    | 1    | FILTER,10 MIC,RETURN LINE       |
| 7     | 06505049 | 1    | CAN/BODY                        |

COMMON BENGAL T4

## PUMP AND GRILL GUARD OPTIONS

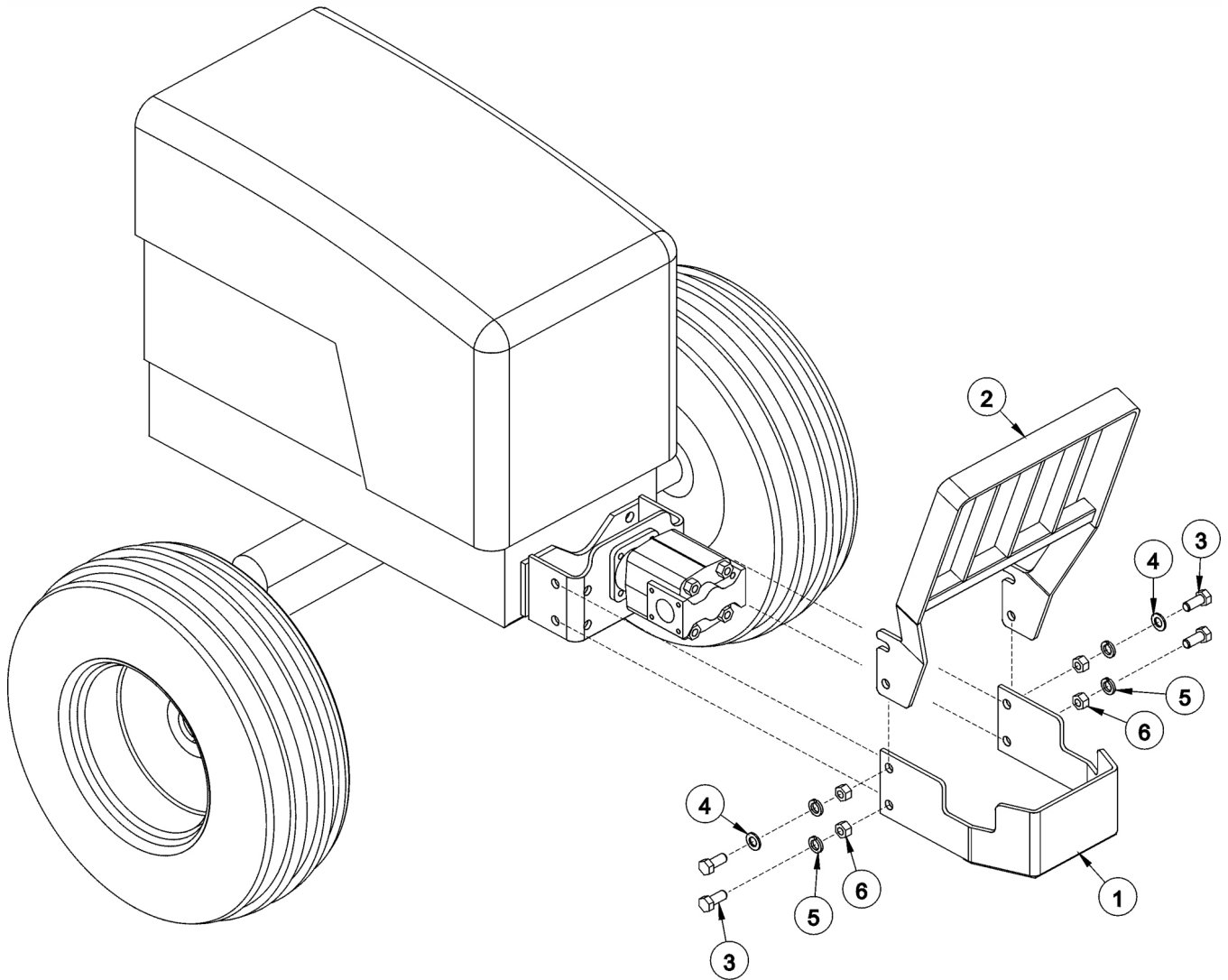

| ITEM | PART NO. | QTY. | DESCRIPTION               |
|------|----------|------|---------------------------|
| 1    | 32430    | 1    | UNIVERSAL PUMP GUARD      |
| 2    | 32737    | 1    | UNIVERSAL GRILL GUARD     |
| 3    | 21833    | 4    | CAPSCREW,3/4" X 2-1/4",NC |
| 4    | 22021    | 2    | FLATWASHER,3/4"           |
| 5    | 21993    | 4    | LOCKWASHER,3/4"           |
| 6    | 21825    | 4    | HEX NUT,3/4",NC           |

# BOOM TRAVEL LOCK

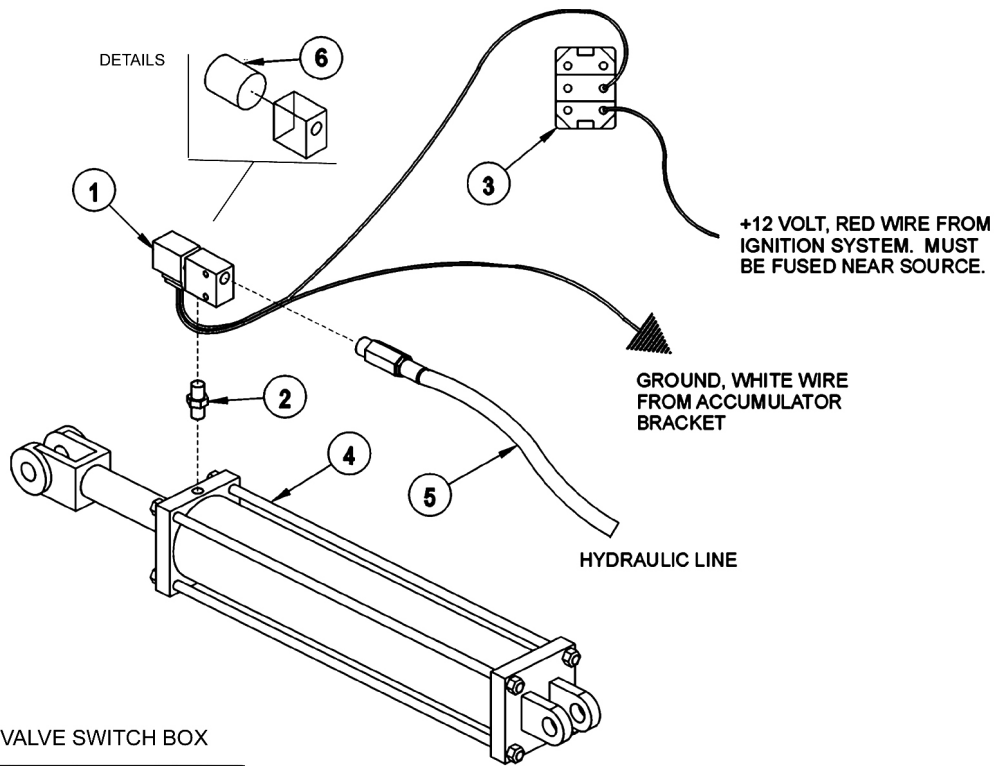

ELECTRONIC LIFT VALVE SWITCH BOX



MANUAL LIFT VALVE SWITCH BOX



| ITEM  | PART NO. | QTY. | DESCRIPTION                             |
|-------|----------|------|-----------------------------------------|
| 1     | 06510050 | 1    | HYDRAULIC TRAVEL LOCK VALVE             |
| 2     | 31329    | 1    | ADAPTER - STANDARD BOOM                 |
| ----- | 31611    | 1    | ADAPTER - EXTENDED BOOM                 |
| 3     | 34532    | 1    | SWITCH,TRAVEL LOCK                      |
| 4     | -----    | -    | MAIN BOOM CYLINDER *REFER TO BOOM ASSY  |
| 5     | -----    | -    | HOSE / FITTINGS *REFER TO BOOM HYD ASSY |
| 6     | 06510092 | 1    | COIL ,TRAVEL LOCK                       |



## MANUAL LIFT VALVE SWITCH BOX

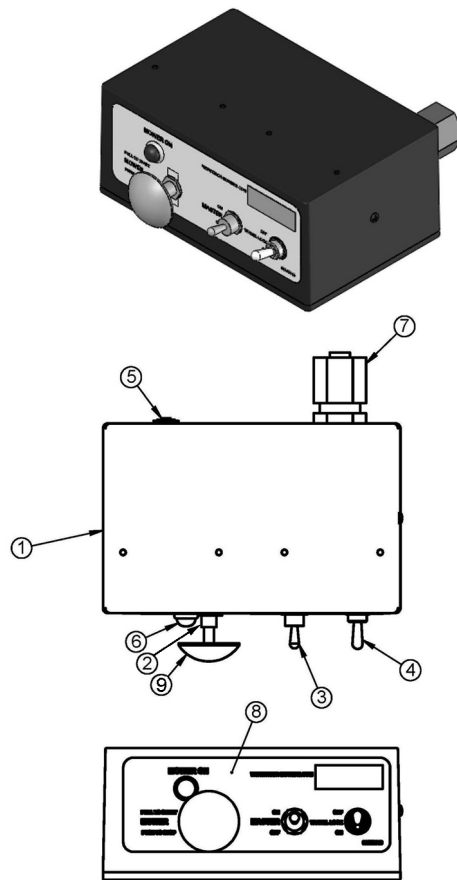

| ITEM | PART NO. | QTY. | DESCRIPTION                   |
|------|----------|------|-------------------------------|
| 1    | 06514012 | 1    | SWBX,ALUM,BLK,06510100        |
| 2    | 35226    | 1    | SWITCH,MOWER,COLEHERSEE       |
| 3    | 33811    | 1    | SWITCH,MASTER/DECK FLOAT      |
| 4    | 34532    | 1    | SWITCH,TRVL LCK               |
| 5    | 06514014 | 1    | BREAKER,10A,SWBX              |
| 6    | 6T3923   | 1    | INDICTATOR LIGHT,ON,RED       |
| 7    | 34540    | 1    | STRAIN RELIEF,3/4,BLACK,NYLON |
| 8    | 06550019 | 1    | DECAL,SWTCHBX,BOOM,CG         |
| 9    | 02964063 | 1    | KNOB,RED                      |
| 10   | 35227    | 1    | RELAY,DP,DT,12V,LY2F,35226    |

# MANUAL LIFT VALVE SCHEMATIC

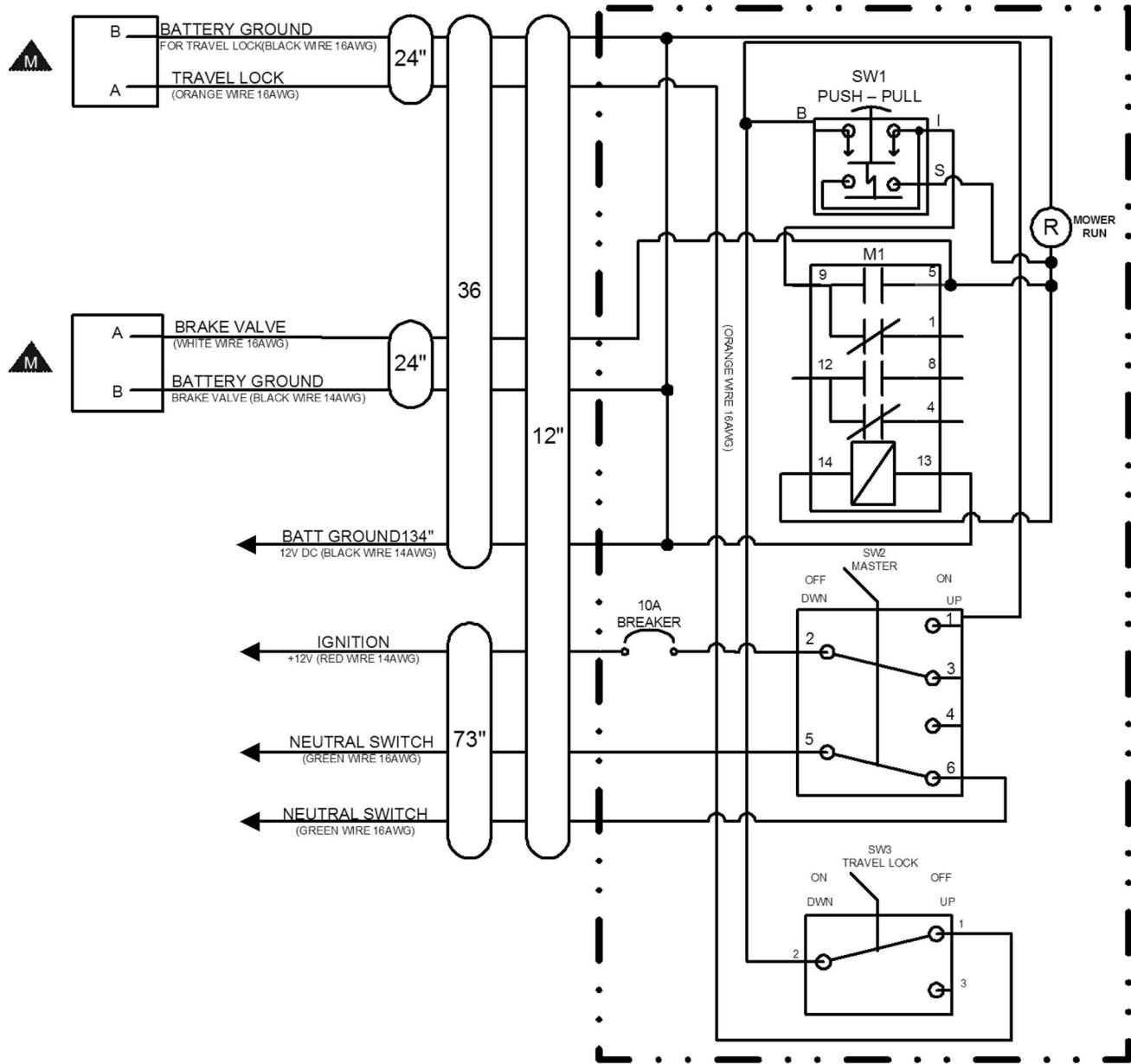

## ELECTRONIC LIFT VALVE SWITCH BOX

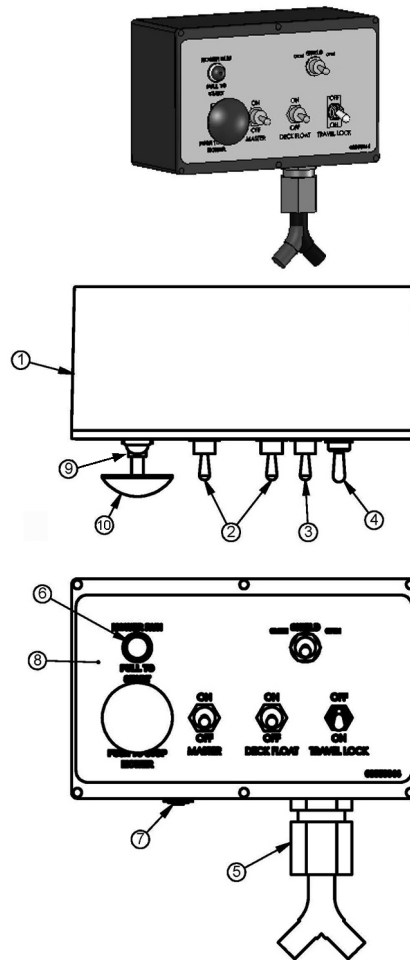

| ITEM | PART NO. | QTY. | DESCRIPTION                    |
|------|----------|------|--------------------------------|
| 1    | 06510196 | 1    | SWBX,ASSY                      |
| 2    | 33811    | 2    | SWITCH,MASTER/DECK FLOAT       |
| 3    | 33813    | 1    | SWITCH,SFTY SHIELD             |
| 4    | 34532    | 1    | SWITCH,TRVL LCK                |
| 5    | 34540    | 1    | STRAIN RELIEF,3/4",BLACK,NYLON |
| 6    | 6T3923   | 1    | INDICTATOR LIGHT,ON,RED        |
| 7    | 06514006 | 1    | BREAKER,15A,SWBX               |
| 8    | 06550044 | 1    | DECAL,SWBX,06510047            |
| 9    | 35226    | 1    | SWITCH,MOWER,COLEHERSEE        |
| 10   | 02964063 | 1    | KNOB,RED                       |
| 11   | 35227    | 1    | RELAY,DP,DT,12V,LY2F,35226     |

# ELECTRONIC LIFT VALVE SCHEMATIC

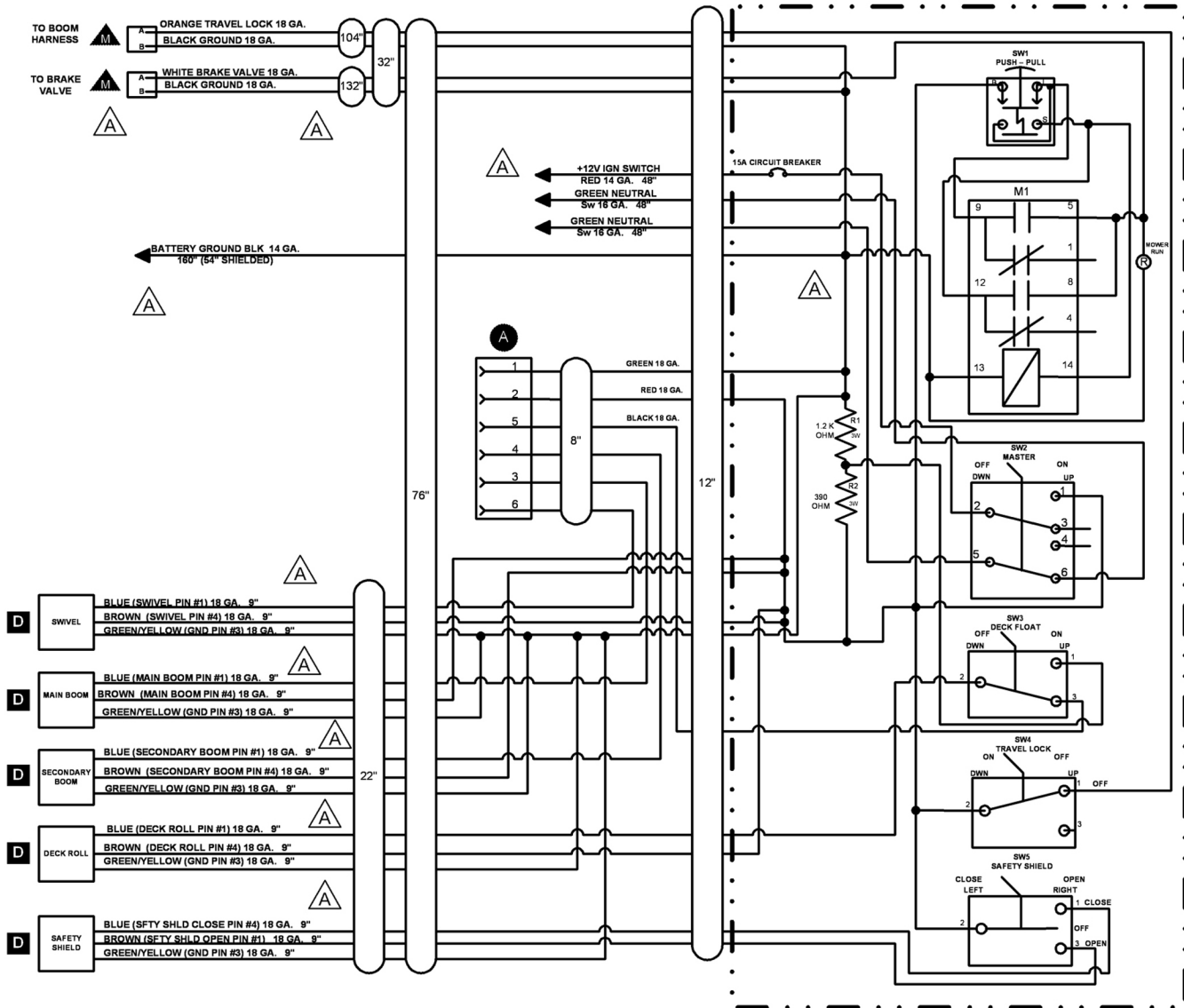

## SOLENOID SWITCH BOX AND WIRING

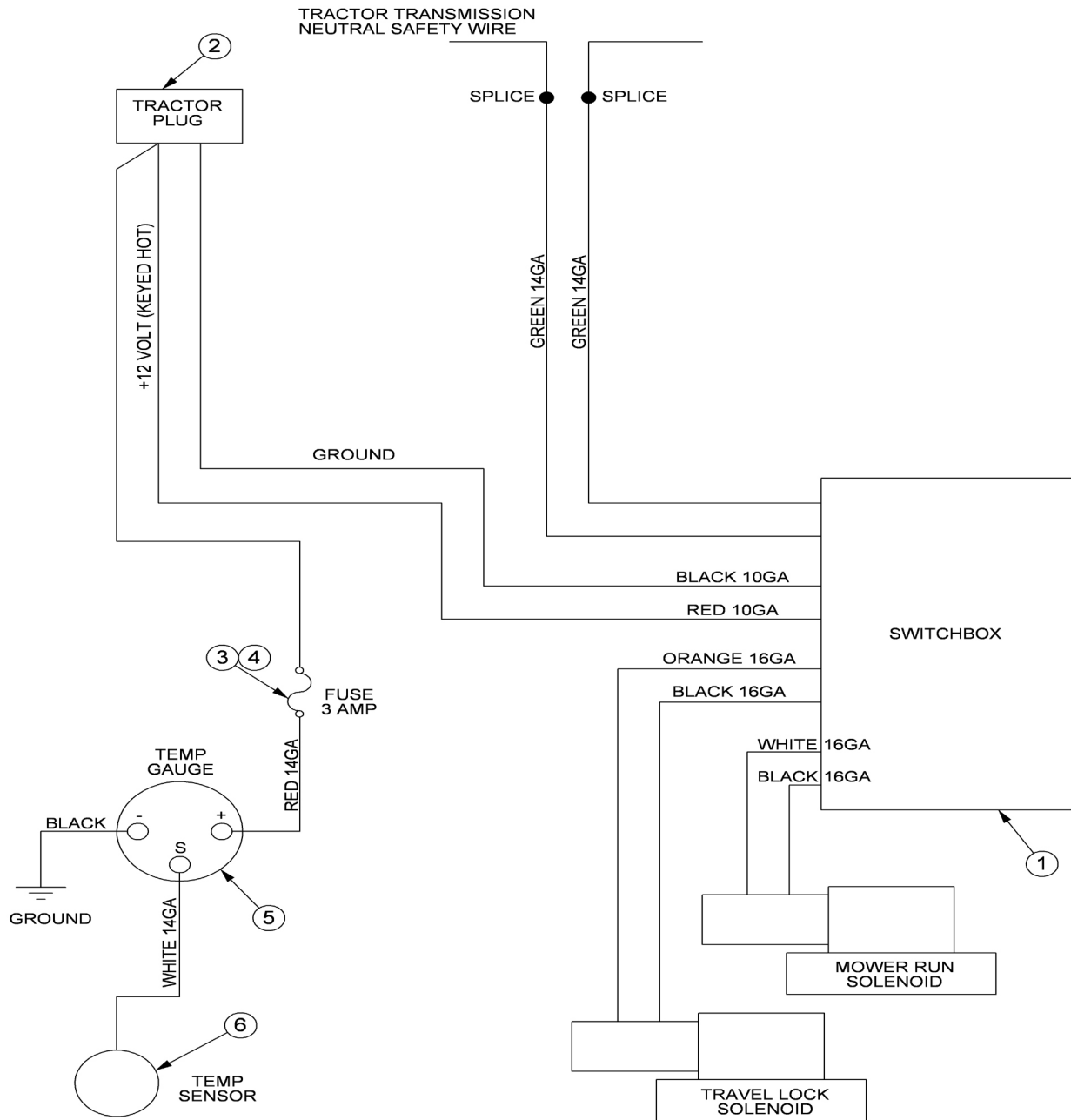

| ITEM | PART NO. | QTY. | DESCRIPTION                  |
|------|----------|------|------------------------------|
| 1    | -----    | -    | SWITCH BOX                   |
| 2    | RE37651  | 1    | PLUG,AUX PWR                 |
| 3    | 24204    | -    | FUSE HOLDER,IN-LINE (OPTION) |
| 4    | 6T3965   | -    | FUSE,3AMP (OPTION)           |
| 5    | 6T3934   | -    | TEMPERATURE GAUGE (OPTION)   |
| 6    | 6T3931   | -    | TEMPERATURE SENSOR (OPTION)  |

## BRAKE VALVE ASSEMBLY

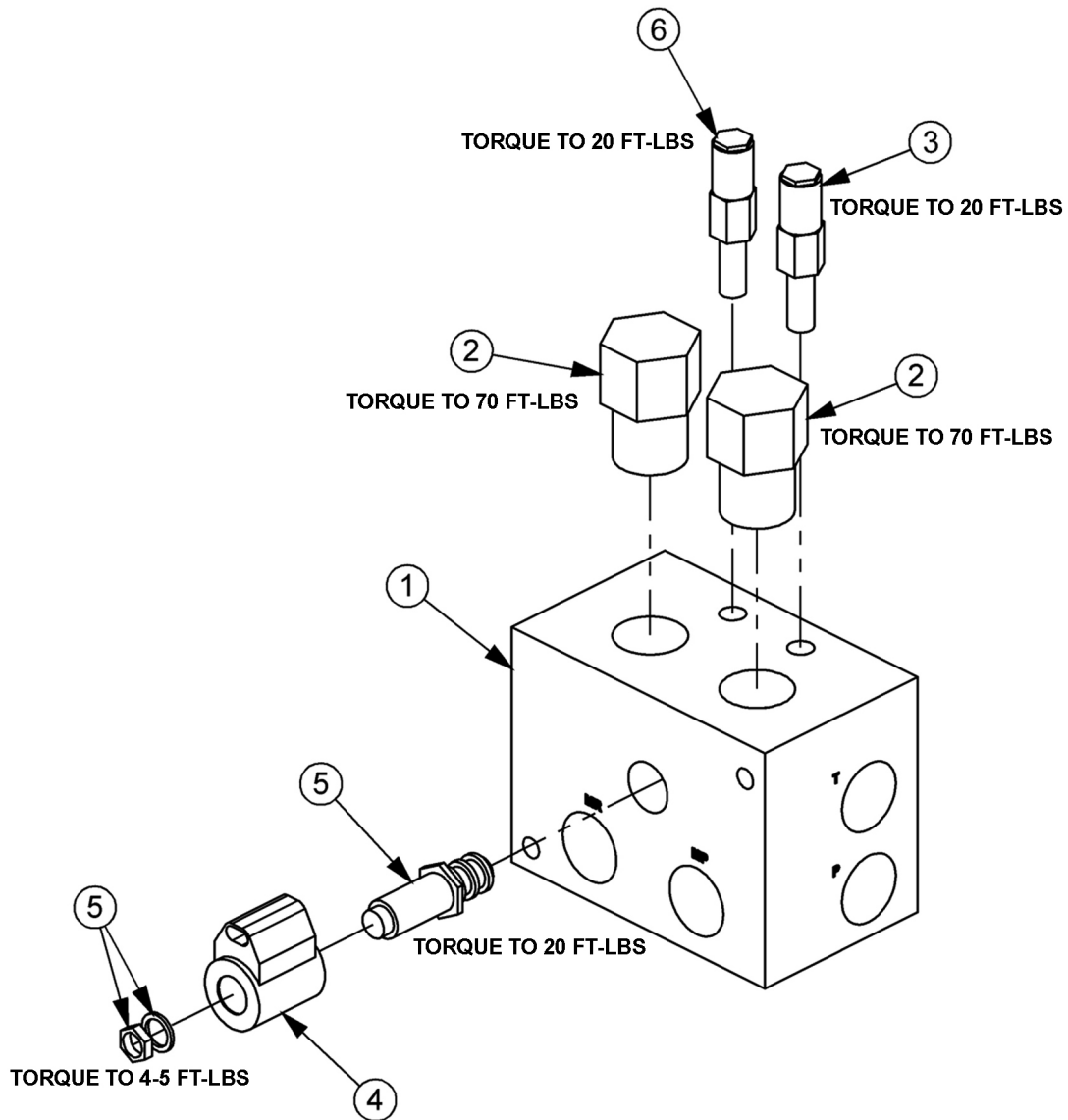

| ITEM | PART NO. | QTY. | DESCRIPTION                                      |
|------|----------|------|--------------------------------------------------|
| ---  | 06510083 | 1    | BRAKE VALVE, ASSY                                |
| 1    | 34092    | 1    | BRAKE VALVE, BLANK                               |
| 2    | 34094    | 2    | LOGIC ELEMENT                                    |
| 3    | 34095    | 1    | RELIEF VALVE, 3000 PSI                           |
| 4    | 06510095 | 1    | METRI PAK COIL                                   |
| 5    | 34093    | 1    | CARTRIDGE, 2 POSITION, 3 WAY (WITH NUT & WASHER) |
| 6    | 34091    | 1    | RELIEF VALVE, 2600 PSI                           |
| ---  | 34096    | 2    | RELIEF SEAL KIT                                  |
| ---- | 34097    | 1    | SOLENOID SEAL KIT                                |
| ---  | 34098    | 2    | ELEMENT SEAL KIT                                 |

## BRAKE VALVE HYDRAULIC SCHEMATIC

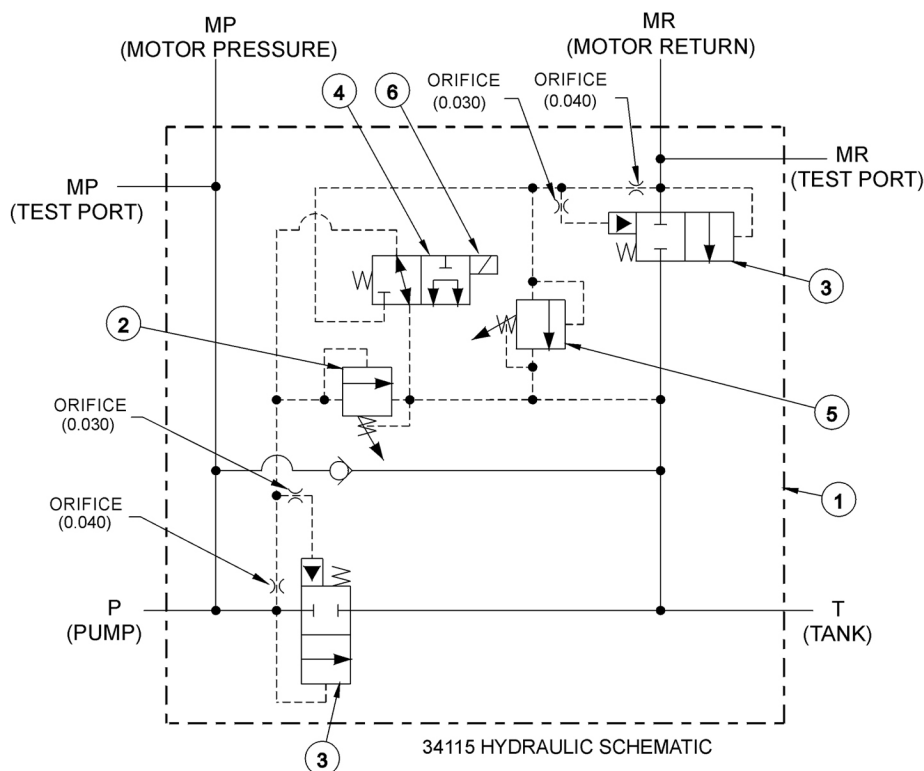

### BRAKE VALVE TROUBLESHOOTING

#### FAILURE MODE:

- MOWER WILL NOT START - system pressure is low (engine not lugging).
- MOWER WILL NOT START - system pressure is high (engine lugging). "MR" port will be high pressure.
- MOWER WILL NOT ROTATE AT FULL SPEED - limited power.
- MOWER BLADE WILL NOT STOP - blade will not stop in proper time.

#### CHECK STEPS

- 1 thru 6
- 7
- 3 thru 5
- 7 thru 9

#### CORRECTIVE STEPS:

1. Check for voltage at solenoid (item 6), voltage must be between 10.2 volts and 13.8 volts.
2. Remove, inspect solenoid and cartridge (items 4, 6) for wear or contamination.
3. Remove, inspect logic elements near "P" port (item 3) for wear or contamination.
4. Remove, inspect 3000 psi relief valve (item 2) for wear or contamination.
5. Remove and inspect orifices near "P" port for contamination.
6. Remove "P" port hose and fitting, visually inspect for contamination, check ball for movement.
7. Remove and inspect orifices near "MR" port for contamination.
8. Remove, inspect 2600 psi relief valve (item 5) for wear of contamination.
9. Remove, inspect logic element near "MR" port (item 3) for wear or contamination.

# ELECTRICAL TROUBLESHOOTING GUIDE

## Joystick Electrical Troubleshooting guide

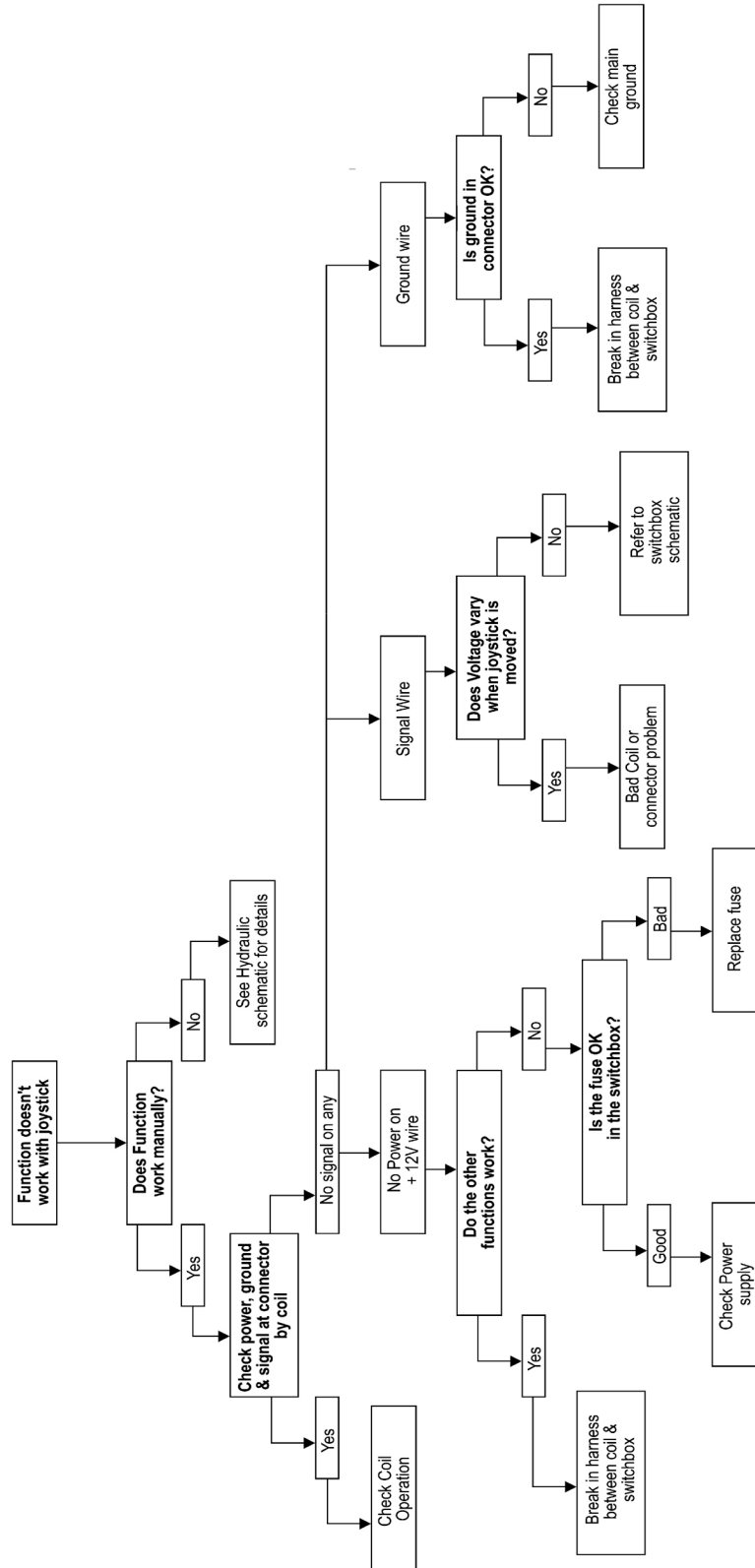



# HYDRAULIC TROUBLESHOOTING GUIDE

## Hydraulic Troubleshooting guide

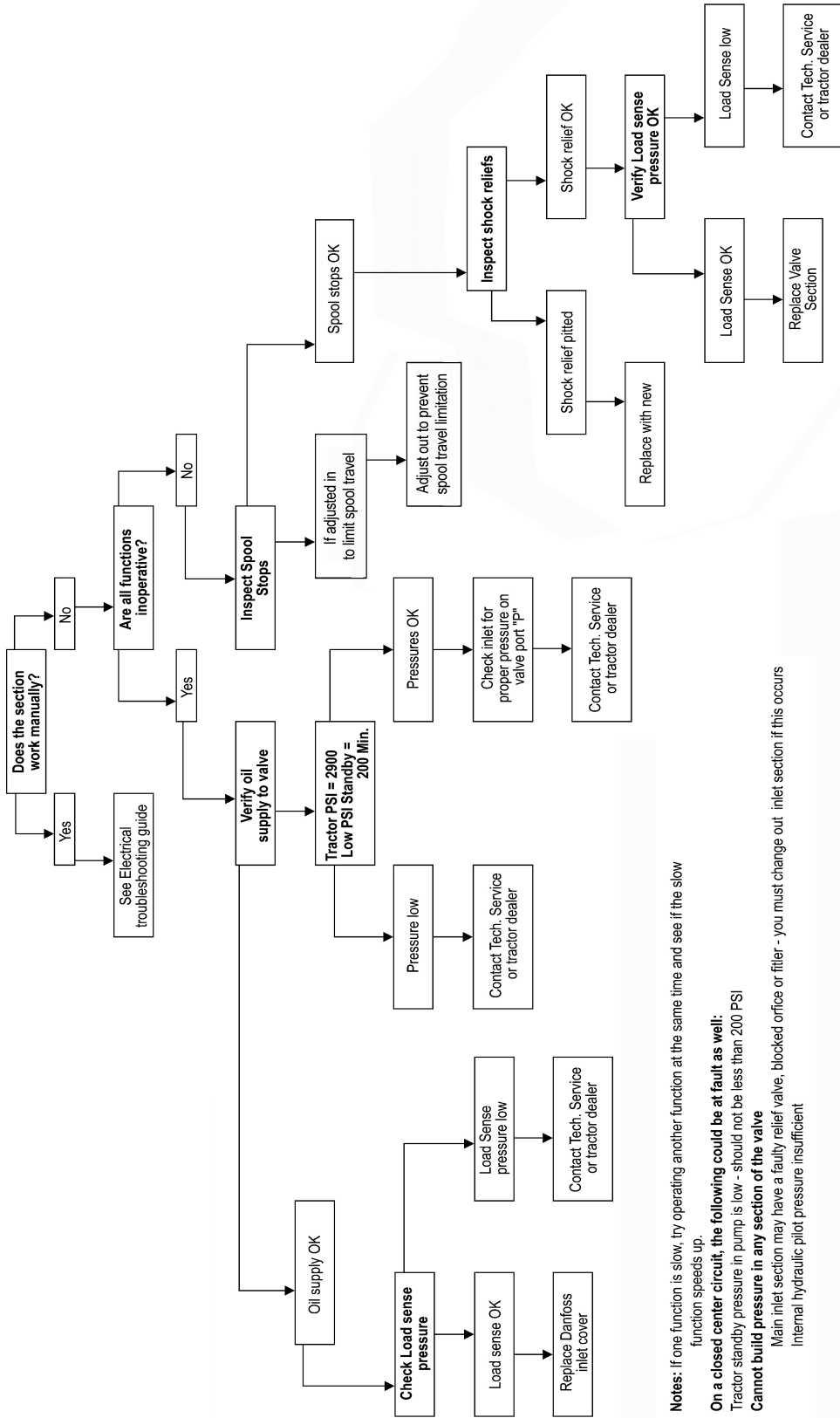

**Notes:** If one function is slow, try operating another function at the same time and see if the slow function speeds up.

**On a closed center circuit, the following could be at fault as well:**

Tractor standby pressure in pump is low - should not be less than 200 PSI

**Cannot build pressure in any section of the valve**

Main inlet section may have a faulty relief valve, blocked orifice or filter - you must change out inlet section if this occurs

Internal hydraulic pilot pressure insufficient

### JOYSTICK TROUBLESHOOTING

#### **Boom operation not responding to joystick movement.**

Isolate hydraulic vs. electronic symptom.

Turn off electronic master switch (preventing electronic actuator on valve from attempting to hold spool in neutral position). With tractor engine running, operate the valve section with the manual handle. If function operates normally, continue with electronic inspection. If function does not operate normally, continue with hydraulic inspection.

#### **Electronic inspection.**

Connect a voltmeter to the cable connector of the valve section that is not operating. This will allow you to measure supply and signal voltage when the joystick is operated.

Main, Secondary, and Swivel Valves – signal voltage should be 50% of supply voltage with joystick in Neutral position, up to 75% of supply voltage in B direction, down to 25% of supply voltage in A direction. Signal voltage should change smoothly with lever movement.

Pin #1 – Signal Voltage, Pin #4 – Power Voltage, Pin #3 – Ground

Deck Roll Valve or Float Valve – signal voltage should be 50% of supply voltage with joystick in Neutral position, up to 65% of supply voltage in B direction, down to 35% of supply voltage in A direction. Signal voltage should change smoothly with lever movement. Signal voltage should be approximately 75% of supply voltage when float switch is operated.

Pin #1 – Signal Voltage, Pin #4 – Power Voltage, Pin #3 – Ground

Shield Valve or On/Off Valve – Voltage on pin #1 should be equal to supply voltage when switch is operated in A direction. Voltage on pin #4 should be equal to supply voltage when switch is operated in B direction.

Pin #1 – Signal Voltage (Shield Open), Pin #4 – Signal Voltage (Shield Close), Pin #3 – Ground

If none of the valve will operate with electrical signal, verify that there is oil pressure at the valve inlet. Electrical Valves must have pilot supply oil to move the spools.

#### **Possible electronic problems.**

Open circuit (broken wire, bad connection or loose connection in switchbox).

Shorted to positive, ground, or other.

Incorrect voltage signal from joystick.

**Continued on next sheet**

## TROUBLESHOOTING - CONTINUED

### Hydraulic inspection.

Install 3 pressure gauges, on the valve inlet (use M port, or tee into hose supplying oil from the pump to the inlet), on the workport that is not operating, and on the LS port.

With the spools in Neutral

Gear pump – P should be approximately 200 psi, LS = 0, workport – pressure on cylinder or function.

LS pump – P should equal pump standby pressure, LS = 0, workport – pressure on cylinder or function.

Pressure Comp pump – P should equal pump standby pressure, LS = 0, workport – pressure on cylinder or function.

Gear pump – P should be approximately 200 psi higher than LS, LS should equal workport, workport – pressure on cylinder or function.

LS pump – P should be LS + standby, LS should equal workport, workport – pressure on cylinder or function.

Pressure Comp pump – P should equal pump standby pressure, LS should equal workport, workport – pressure on cylinder or function.

Operate one spool, measure pressures with function at end of travel or stop

Gear pump – P should equal valve relief setting or workport shock valve setting. LS should equal workport. Workport should equal relief setting or workport shock valve setting.

LS pump – P should equal valve relief setting, pump max pressure setting, or workport shock valve setting. LS should equal workport. Workport should equal relief setting, pump max pressure setting, or workport shock valve setting.

Pressure Comp pump – P should equal pump standby pressure, LS should equal workport. Workport should equal pump standby pressure or workport shock valve setting.

Operate more than one spool.

Gear pump – P should approximately 200 psi higher than LS. LS should equal highest workport pressure. Workport – pressure on cylinder or function.

LS pump – P should be LS + standby pressure. LS should equal highest workport pressure. Workport – pressure on cylinder or function.

Pressure Comp pump. P should equal pump standby pressure. LS should equal highest workport pressure. Workport – pressure on cylinder or function.

### Possible hydraulic problems.

Cylinder leak.

LS signal leaking to tank before reaching pump LS port.

Hydraulic system or pump not supplying flow to valve.

## WHEEL WEIGHT - BENGAL 18

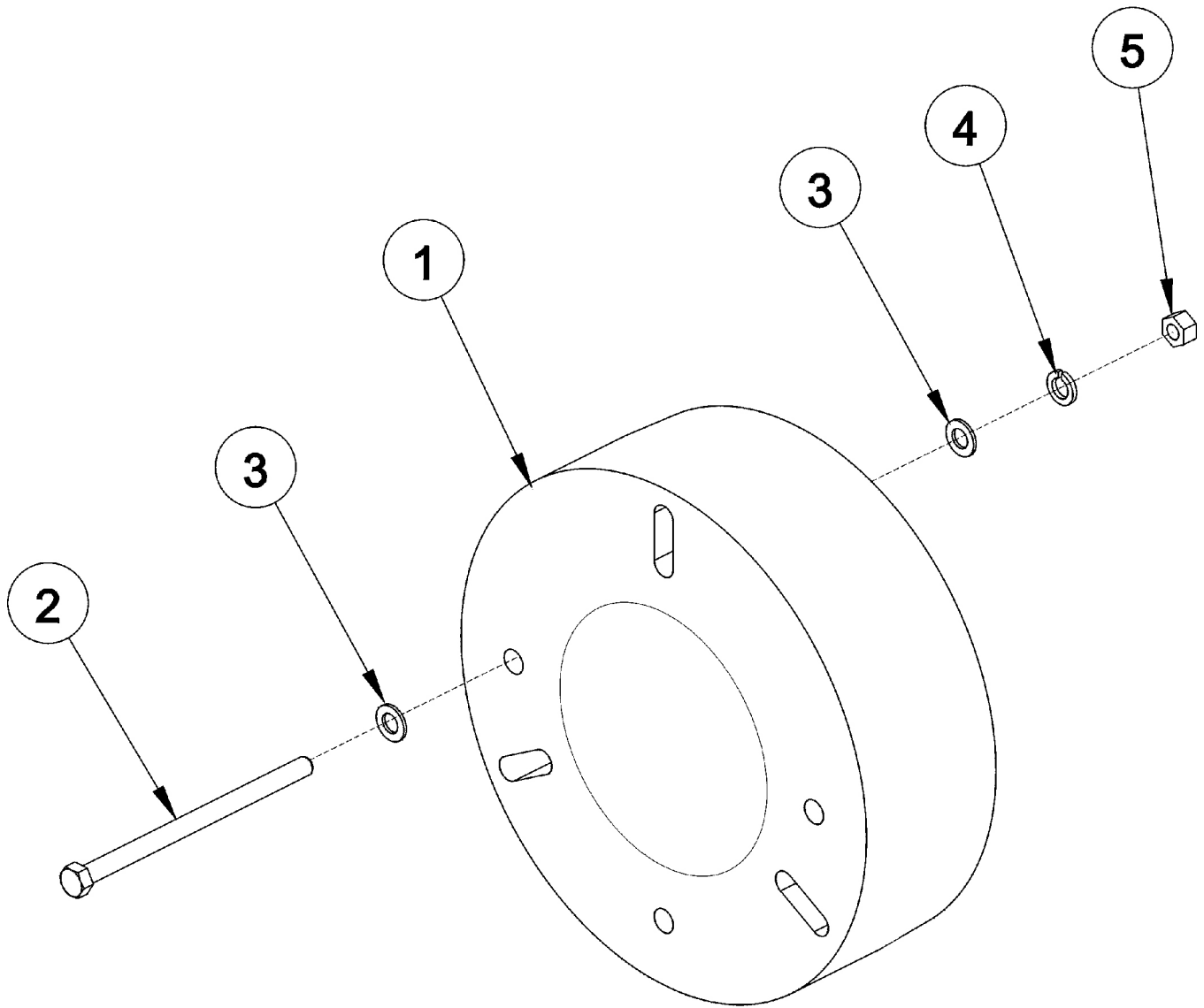

| ITEM | PART NO. | QTY. | DESCRIPTION            |
|------|----------|------|------------------------|
| 1    | 30687    | 1    | 500# WHEEL WEIGHT      |
| 2    | 21956    | 4    | CAPSCREW,3/4" X 13",NC |
| 3    | 22021    | 8    | FLATWASHER,3/4"        |
| 4    | 21993    | 4    | LOCKWASHER,3/4"        |
| 5    | 21825    | 4    | HEX NUT,3/4",NC        |

COMMON BENGAL T4

# **WARRANTY SECTION**



## WARRANTY INFORMATION

Tiger Corporation, 3301 N. Louise, Sioux Falls, South Dakota, warrants to the original Retail Customer, the new Tiger equipment is free of defects in material and workmanship. Any part of equipment that in Tiger's judgement, show evidence of such defects will be repaired or replaced without charge, provided that the failure of part(s) shall have occurred within twelve (12) months from the date of delivery of said equipment to the Retail Customer. Expendable components such as knives, oil, chain sprockets, skid shoes, knife mounting disks and the like are excluded but not limited to this warranty.

The Retail Customer must pay the transportation cost to and from the Tiger Dealer's service shop for warranty service. Warranty service will be performed by the Tiger Dealer from whom the equipment was purchased, during service shop regularly scheduled days and hours of operation.

All Tiger obligation under this warranty shall be terminated if the equipment is modified or altered in ways not approved in writing by Tiger, if repair parts other than genuine Tiger repair parts have been used, or if the equipment has been subject to misuse, neglect, accident, improper maintenance or improper operation.

Tiger Corporation reserves the right to make improvements in design or changes in specification at any time without incurring any obligation to owners of equipment previously sold.

No agent or person has authority to alter, add to or waive the above warranties which are agreed to be in the only warranties, representations or promises, expressed or implied, as to the quality or performance of the products covered and which do not include any implied warranty of merchantability or fitness. In no event will Tiger be liable for incidental or consequential damages or injuries, including, but not limited to, loss of profits, rental or substitute equipment or other commercial loss.

**THERE ARE NO WARRANTIES WHICH EXTEND  
BEYOND THOSE EXPRESSED HEREIN.**

It is the Purchasers obligation to sign the warranty registration form **AFTER** he / she has Read and Understands the Operation and Safety Instructions stated within this manual.

## **ONE LAST WORD**

This manual cannot possibly cover all of the potentially hazardous situations you will encounter. By being familiar with the safety rules, operating and maintenance instructions in this manual you can help prevent accidents. The objective of this manual is to help make you a better operator. Remember, **SAFETY IS YOU!**



1012

Your safety and the safety of those around you depends on **YOU**. Common sense should play a large role in the operation of this machine.

Since we at Tiger Corporation are constantly striving to improve our products, we reserve the right to change specifications or design at any time.



## TO THE OWNER / OPERATOR / DEALER



To keep your implement running efficiently and safely, read your manual thoroughly and follow these directions and the Safety Messages in this manual and on the machine. The table of contents clearly identifies each section where you can easily find the information you need.

The Occupational Safety and Health Act (OSHA 1928.51 subpart C) makes the following minimum requirements for tractor operators.

### **OWNER REQUIREMENTS:**

1. Provide a Roll-Over-Protective Structure that meets the requirements of this Standard; and
2. Provide Seatbelts that meet the requirements of this Standard and SAE J3C; and
3. Ensure that each employee uses such Seatbelt while the tractor is moving; and
4. Ensure that each employee tightens the Seatbelt sufficiently to confine the employee to the protected area provided by the ROPS.

### **OPERATOR REQUIREMENTS:**

1. Securely fasten seatbelt if the tractor has a ROPS.
2. Where possible, avoid operating the tractor near steep ditches, embankments, and holes.
3. Reduce speed when turning, crossing slopes, and on rough, slick, or muddy surfaces.
4. Stay off slopes too steep for safe operation.
5. Watch where you are going – especially at row ends, on roads, and around trees.
6. Do Not permit others to ride.
7. Operate the tractor smoothly – no jerky turns, starts, or stops.
8. Hitch only to the draw-bar and hitch points recommended by the tractor manufacturer.
9. When the tractor is stopped, set brakes securely and use park lock, if available



Printed in USA  
© Tiger Corporation