



BENGAL ASSEMBLIES

NH TS6.1XX T4B 2 WHEEL DRIVE

Current as of 4/8/2016



PARTS LISTING WITH MOUNTING AND OPERATING INSTRUCTIONS

Tiger Corporation
3301 N. Louise Ave.
Sioux Falls, SD 57107
1-800-843-6849
1-605-336-7900
www.tiger-mowers.com

06020024

HC H<9 CK B9F #CD9F5HCF #895 @F





01/11 | { ^ } • Á ã [çā * Á æ • Á æ ^ Á [() ã ã Á æ ã ã | • Ë V @ ! ^ Á Á [Á ~ à • æ (Á | Á æ æ ç ~ É
 • æ Ë á á ^ Á] ^ ã | Á @ Á & *) á ^ Á @ Á [() ã ã Á æ ã á • ã á Á || , • Á æ [] ã | Á æ ç Á | æ ç Á • É
 V @ Á æ ~ æ ç ! ^ Á æ Á • á ^ Á @ Á] | { ^ } () Á Á Á • á Á ã ã | Á æ ç Á ~ á { ^ } () | [] | ^ |
 æ æ ç á Á Á á á á ^ Á @ Á & Á Á æ æ ^ } • É

69: CF9 MCI GH5FH° Ü^ æ á @ Á æ ç Á ^ • æ ^ Á } Á @ Á] | { ^ } () á á @ , } Á @ Á æ ~ æ É
 U à • ^ | ç ^ Á @ Á ^ | • Á Á æ ç Á æ á Á • ^ Á { [] Á ^ } • Á

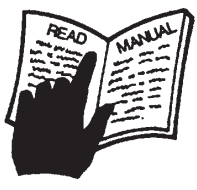

F958 5B8 1 B89FGH5B8 H<G A5BI 5 @ BcbE9b [] g l 'gdYU] b ['cdYfUrcfg'k] 'bYYX'rc ; 9H
 H<9 A5BI 5 @HF5BG @H98 Ug'bYYXYX°

DANGER

FAILING TO FOLLOW SAFETY MESSAGES AND OPERATING INSTRUCTIONS CAN CAUSE SERIOUS BODILY INJURY OR EVEN DEATH TO OPERATOR AND OTHERS IN THE AREA.

<p>1.</p> 	<p>2. NO RIDERS. NO CHILDREN OPERATORS.</p> 	<p>3. USE SAFETY SHOES, HARD HAT, SAFETY GLASSES, SEAT BELTS, ROPS & OPS</p> 	<p>4. BLOCK UP SECURELY BEFORE WORKING UNDER.</p> 
---	---	---	---

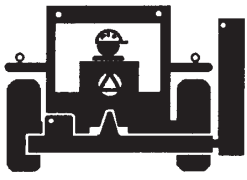
- Study and understand Operator's Manuals, Safety Decals, and Instructional Decals for tractor and implement to prevent misuse, abuse, and accidents. Practice before operating in a confined area or near passersby.
 - Learn how to stop engine suddenly in an emergency. Be alert for passersby and especially children
- Allow no children on or near folding mower or tractor. Allow no riders on tractor or implement. Falling off may cause serious injury or death from being run over by tractor or mower or contact with rotating blades.
- Operate only with tractor having Roll-Over Protective Structure (ROPS) and with seat belt securely fastened to prevent injury and possible death from falling off or tractor overturn.
 - Personal Protective Equipment such as Hard Hat, Safety Glasses, Safety Shoes, & Ear Plugs are recommended.
- Block up or support raised machine and all lifted components securely before putting hands or feet under or working underneath any lifted component to prevent crushing injury or death from sudden dropping or inadvertent operation of controls. Make certain area is clear before lowering or folding
- Before transporting, put Lift Lever in detent or full-lift position. Install Transport Safety Devices securely on folding mowers. Put Booms securely in Transport Rest.
 - Folding and Boom Mowers have raised center of gravity. Slow down when turning and on hillsides.
- Make certain that SMV sign, warning lights, and reflectors are clearly visible. Follow local traffic codes.
- Never operate with Cutting Head or Folding Section raised if passersby, bystanders, or traffic are in the area to reduce possibility of injury or death from objects thrown by Blades under Guards or mower structure.
- Before dismounting, secure implement in transport position or lower to ground.
 - Put tractor in park or set brake, disengage PTO, stop engine, remove key, and wait until noise of rotation has ceased to prevent crushing by entanglement in rotating parts which could cause injury or death.
 - Never mount or dismount a moving vehicle. Crushing from rollover may cause serious injury or death.

<p>5. TRANSPORT SAFELY, LOCK UP.</p> 	<p>6. USE SMV, LIGHTS, & REFLECTORS.</p> 	<p>7. DO NOT OPERATE WITH CUTTER OR WING RAISED.</p> 	<p>8. DO NOT MOUNT OR DISMOUNT WHILE MOVING.</p> 
--	--	---	--

Warranty Information: Read and understand the complete Warranty Statement found in this manual. Fill out the
 Warranty Registration form in full and return it within 90 days. Make certain the Serial Number of the machine is
 recorded on the Warranty Card, and form that you retain.

FORWARD

This manual contains information about many features of the Tiger mowing and roadside maintenance equipment. Some of these include: Safety precautions, Assembly instructions, Operations, Maintenance and Parts. This manual will also assist you in the proper break-in, daily care, and troubleshooting of your new mower.

We recommend that you read carefully the entire manual before operating the unit. Also, time spent in becoming fully acquainted with its performance features, adjustments, and maintenance schedules will be repaid in a long and satisfactory life of the equipment.

Troubleshooting - Please, before you call, help us to help you!

Please look at the equipment to observe what is happening, then:

- Classify the problem
 - Hydraulic, electrical or mechanical - Read the trouble shooting section
 - Tractor or Truck chassis - Contact vehicle dealer

- If unable to correct the problem yourself, contact your local Tiger Dealer after gathering:
 - Machine model _____
 - Serial number _____
 - Dealer name _____
 - Detailed information about the problem including results of troubleshooting

Attention Owner / Operator / Dealer: It is your obligation to read, and understand, the warranty information section located at the back of this manual denoting that the purchaser understands the safety issues relating to this machine and has received and will read a copy of this manual.

If at any time, you have a service problem with your Tiger mower, Contact your local dealer for service and parts needed.

MANUFACTURED BY:

Tiger Corporation

3301 N. Louise Ave.

Sioux Falls, SD 57107

1-800-843-6849

1-605-336-7900

www.tiger-mowers.com

DISTRIBUTED BY:

1- _____ - _____ - _____

1- _____ - _____ - _____

TABLE OF CONTENTS

SAFETY SECTION_____	1
ASSEMBLY / MOUNTING SECTION_____	2
OPERATION SECTION_____	3
MAINTENANCE SECTION_____	4
PARTS SECTION_____	5
COMMON PARTS SECTION_____	6
WARRANTY INFORMATION_____	7



1012

This symbol means:

CAUTION – YOUR SAFETY IS AT RISK!

When you see this symbol, read and follow the associated instructions carefully or personal injury or damage may result.

Tiger is a registered trademark.



SAFETY SECTION

Safety Section 1-1

SAFETY

GENERAL SAFETY INSTRUCTIONS AND PRACTICES

A careful operator is the best operator. Safety is of primary importance to the manufacturer and should be to the owner/operator. Most accidents can be avoided by being aware of your equipment, your surroundings, and observing certain precautions. The first section of this manual includes a list of Safety Messages that, if followed, will help protect the operator and bystanders from injury or death. Read and understand these Safety Messages before assembling, operating or servicing this Implement. This equipment should only be operated by those persons who have read the manual, who are responsible and trained, and who know how to do so responsibly.



The Safety Alert Symbol combined with a Signal Word, as seen below, is used throughout this manual and on decals which are attached to the equipment. The Safety Alert Symbol means: "ATTENTION! BECOME ALERT! YOUR SAFETY IS INVOLVED!" The Symbol and Signal Word are intended to warn the owner/operator of impending hazards and the degree of possible injury faced when operating this equipment.

Practice all usual and customary safe working precautions and above all--- remember safety is up to YOU. Only YOU can prevent serious injury or death from unsafe practices.



Indicates an imminently hazardous situation that, if not avoided, WILL result in DEATH OR VERY SERIOUS INJURY.



Indicates an imminently hazardous situation that, if not avoided, COULD result in DEATH OR SERIOUS INJURY.



Indicates an imminently hazardous situation that, if not avoided, MAY result in MINOR INJURY.



Identifies special instructions or procedures that, if not strictly observed, could result in damage to, or destruction of the machine, attachments or the environment.

NOTE: *Identifies points of particular interest for more efficient and convenient operation or repair.*

READ, UNDERSTAND, and FOLLOW the following Safety Messages. Serious injury or death may occur unless care is taken to follow the warnings and instructions stated in this Manual and in the Safety Messages on the implement. Always follow the instruction in this manual and use good common sense to avoid hazards.



NOTE: *If you want a translation of this safety section in one of the following Languages, please contact: Translations at 1502 E. Walnut Street Seguin, TX 78155; Fax: (830) 372-9529; Safety Section Translations are available in Spanish, Portuguese, French, German, Russian. PN GS01*

SAFETY

SAFETY

Operator Safety

				
Read and understand Operator's Manual	Always wear Safety Glasses	Wear Hard Hat Safety Shoes	Never use Drugs or Alcohol when operating equipment	Wear Safety Vest when operating on or near roads

⚠ WARNING

TO AVOID SERIOUS INJURY OR DEATH DO THE FOLLOWING:

- **READ, UNDERSTAND** and **FOLLOW** Operator's Manual instructions, Warnings and Safety Messages.
- **WEAR SAFETY GLASSES**, safety shoes, hard hat, hearing protection and gloves when operating or repairing equipment
- **WEAR** appropriate breathing respirator when operating in dusty conditions to avoid respiratory diseases.
- **DO NOT WEAR** loose clothing or jewelry to avoid rotating parts entanglement injury.
- **DO NOT USE DRUGS** or **ALCOHOL** before or while operating equipment.
- **DO NOT ALLOW** anyone to operate equipment under the influence of drug or alcohol.
- **CONSULT** medical professional for medication impairment side effects.
- **STAY CLEAR** of hot surfaces such as Mufflers, hydraulic pumps, valves and tanks.
- **STAY ALERT**, prolonged operation can cause fatigue, **STOP** and **REST**.

GENERAL OPERATING SAFETY

VISIBILITY CONDITIONS WHEN MOWING:

- **OPERATE IN DAYLIGHT** or with lights that gives at least 100 yards clear visibility.
- **BE ABLE TO SEE** and identify passersby, steep slopes, ditches, drop-offs, overhead obstructions, power lines, debris and foreign objects.
- Avoid backing up while mowing, vision may be limited, severe damage or injury can occur.
- **DO NOT** run tractor in enclosed building without adequate exhaust ventilation.

GROUND SPEED WHEN MOWING:

- **NORMAL SPEED** range is between 1 to 2 mph(1-3 kph).
- **ADJUST MOWING SPEED** for terrain conditions and grass type, density and cut height.
- **REDUCE MOWING SPEED** when near steep slopes, ditches, drop-offs, overhead obstructions, power lines and to avoid debris and foreign objects.

TRACTOR and MOWER

- **DO NOT** operate the tractor or mower unless the equipment is maintained and operating properly.
- **DISCONTINUE OPERATION** if tractor or mower electrical and hydraulic controls do no function properly.
- **DISCONTINUE OPERATION** of the tractor if the braking or steering systems do not function properly.
- **DO NOT** operate the tractor or mower if there are any hydraulic leaks.

INSECT INFESTATION

- **DO NOT** operate in areas where bees or insects may attack unless you **WEAR PROTECTIVE CLOTHING** or use enclosed tractor cab.

PTO SPEED:





- **DO NOT EXCEED IMPLEMENT RATED PTO SPEED**
- **AVOID** exceeding rated PTO speeds that may result in broken drivelines or blade failures.

SAFETY SIGNS:

- **REPLACE** missing, damaged or unreadable safety signs immediately. **PN OSBM-01**

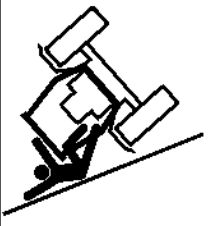
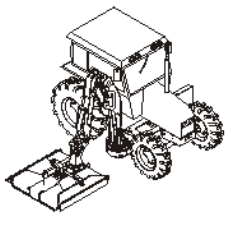
SAFETY

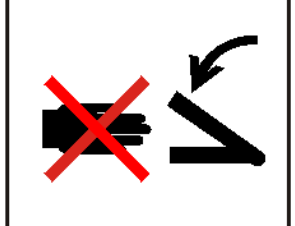
CRUSHING HAZARDS

				
Crushing injury from roll over	Use Cab Tractor With Boom Mowers	Always wear seatbelt	Pinch Point Hazard Keep Hands and body parts clear of pinch points	Crushing injury from boom or mower head falling



TO AVOID SERIOUS INJURY OR DEATH FROM FALLING OFF TRACTOR, EQUIPMENT RUN OVER, ROLLOVER AND CRUSHING BY FALLING WING OR IMPLEMENT:

- USE ROPS and SEAT BELT equipped tractors for mowing operations.
- KEEP ROPS lock in up position.
- ALWAYS BUCKLE UP seat belt when operating tractor and equipment.
- ONLY OPERATE tractor and equipment while seated in tractor seat.

WHEN RAISING BOOM MOWER:

- Raise or lower ONLY WHILE SEATED in tractor seat with seat belt buckled.
- KEEP BYSTANDERS CLEAR of area TO AVOID crushing.
- KEEP sufficient clearance around implement and wings TO AVOID contacting buildings or overhead power lines.

LIFTED Equipment can fall from mechanical or hydraulic failure or inadvertent Control Lever movement.



TO AVOID EQUIPMENT FALLING while working near or under lifted boom, components and Mower Head:

- SECURELY SUPPORT or block up raised equipment, wings and components.
- BLOCK UP and securely support equipment before putting hands, feet or body under raised equipment or lifted components.
- KEEP BYSTANDERS CLEAR of raised boom or mower head until securely blocked up.

WHEN PARKING Implement and Tractor:

- LOWER Mower Head to the ground or BLOCK lifted parts before leaving equipment.
- NEVER leave implement unattended in a raised position.







TO AVOID CHILDREN FALLING OFF OR BEING CRUSHED BY EQUIPMENT:

- NEVER ALLOW children to play on or around Tractor or Implement.
- DO NOT operate without operator CAB or OVERHEAD protection. Falling limbs and debris can cause injuries. *PN CHBM-01*

SAFETY

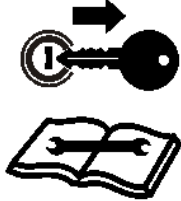
SAFETY

CONNECTING OR DISCONNECTING IMPLEMENT SAFETY

			
<p>Stop Tractor Remove Key Read Manual</p>	<p>Crushing Hazard Do Not get under boom when connecting mower head to boom</p>	<p>Stability Hazard Ensure 20% of tractor weight is on front wheels</p>	<p>Stability Hazard Ensure 1500lbs down force on left tire with boom extended</p>



TO AVOID SERIOUS INJURY OR DEATH FROM BEING CRUSHED BY TRACTOR OR IMPLEMENT:

WHEN connecting mower head to the boom:

- **KEEP BYSTANDERS AWAY** from tractor and mower.
- Ensure there is enough room to lift and swing the boom with out hitting objects

BEFORE connecting and disconnecting the mower head or boom:

- **STOP TRACTOR ENGINE**, place transmission into park, engage parking brake and remove key.

WHEN connecting and disconnecting the mower head or boom:

- **DO NOT** crawl or walk under raised mower head or boom. *(Refer to Instructions in Operation Section)*

WHEN CONNECTING IMPLEMENT DRIVELINE:(If equipped)

TO AVOID implement driveline coming loose during operation:

- **LUBRICATE** yoke spring locking collar to ensure it freely slides on PTO shaft.
- **SECURELY** seat yoke locking balls in PTO shaft groove.
- **PUSH** and **PULL DRIVELINE** on both the tractor and implement **PTO SHAFTS** to ensure it is **SECURELY ATTACHED**.

TO AVOID broken driveline during operations:





- **CHECK** driveline for proper length between PTO shaft and implement gearbox shaft.*(Refer to Instructions in Operation Section)*
- Drivelines too short can pull apart or disengage.
- Drivelines too long can bottom out.
- Bottoming driveline telescoping assembly will stop sliding and become solid.
- Driveline bottoming can push through support bearings and break off PTO shaft.

CONTACT DEALER if implement driveline does not match Tractor PTO shaft:

- **DO NOT USE PTO ADAPTER.**
Using a PTO adapter can cause:
 - Excessive vibration, thrown objects, blade and implement failures by doubling operating speed.
 - Increased working length exposing unshielded driveline areas and entanglement hazards. *PN CDBM-01*

SAFETY

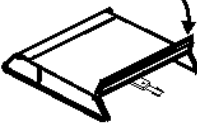
THROWN OBJECTS HAZARDS

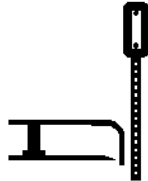
				
Mower Thrown Objects Hazard	Raised Mower Thrown Objects	Keep mower door closed when traffic comes within 300 feet	Inspect Area remove foreign objects	Do not let blades contact solid objects



ROTARY MOWERS CAN THROW OBJECTS 300 FEET OR MORE UNDER ADVERSE CONDITIONS.

TO AVOID SERIOUS INJURY OR DEATH TO OPERATOR OR BYSTANDERS FROM THROWN OBJECTS:

- KEEP bystanders 300 feet away

STOP MOWING IF PASSERSBY ARE WITHIN 300 FEET UNLESS:

- **ALL THROWN OBJECT SHIELDING** including, Front and Rear Deflectors, Chains Guards, Steel Guards, Bands, Side Skirts and Skid Shoes in place and in good condition when mowing.
- Mower is close and parallel to ground without exposing blades.
- **MOWING AREA** has been inspected and foreign materials and debris have been removed.
- **DO NOT** shred or mow loose or previously cut material if **BYSTANDERS** are within 300 feet.
- **PASSERSBY** are inside enclosed vehicle.

INSPECT AREA FOR POTENTIAL THROWN OBJECTS BEFORE MOWING:

- **REMOVE** debris, rocks, wire, cable, metal objects and other foreign material from area.
Wire, cable, rope, chains and metal objects can be thrown or swing outside deck with great velocity:
 1. **MARK** objects that cannot removed.
 2. **AVOID** these objects when mowing.

HIGH GRASS and WEED AREA INSPECTION:

- **INSPECT** for and **REMOVE** any hidden large debris.
- **MOW** at Intermediate height
- **INSPECT** and remove remaining debris
- **MOW** at final height.

MOWER THROWN OBJECT SHIELDING:





- **KEEP** all thrown object shielding including, Front and Rear Deflectors, Chains Guards, Steel Guards, Bands, Side Skirts and Skid Shoes in place and in good condition when mowing.
- **DO NOT OPERATE** with any thrown object shielding missing, damaged or removed.

RIGHT OF WAY (Highway) MOWING

- Stop mowing if any bystander comes within 300 feet of the mower.
- No shielding is 100% effective in preventing thrown objects. To Reduce Possibility of Injury:
 1. **MAINTAIN MOWER SHIELDING**, side skirts, skid shoes, and blades in good operational condition,
 2. **RAISE CUTTING HEIGHT** to **6 INCHES** minimum,
 3. **INSPECT AREA** thoroughly before mowing to **REMOVE** potential **THROWN OBJECT HAZARDS**,
 4. **NEVER ALLOW BLADES** to **CONTACT SOLID OBJECTS** like wire, rocks, post, curbs, guardrails, or ground while mowing. *PN TOBM-01*

SAFETY

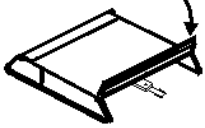
THROWN OBJECTS HAZARDS (Continued)

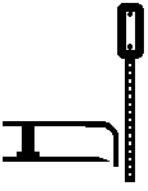
				
Mower Thrown Objects Hazard	Raised Mower Thrown Objects	Keep mower door closed when traffic comes within 300 feet	Inspect Area remove foreign objects	Do not let blades contact solid objects

MOWER OPERATION:

- **DO NOT** exceed mower's rated Cutting Capacity or cut non-vegetative material.
- **USE ENCLOSED TRACTOR CABS** when two or more mowers are operating in mowing area.
- Do Not mow in areas where bees or insects may attack unless you **WEAR PROTECTIVE CLOTHING** or use enclosed tractor cab.
- **ADJUST** mower head close and parallel to ground without exposing blades.
- **ADJUST** cutting **HEIGHT** to **AVOID BLADE CONTACT** with solid objects like wire, rocks, posts, curbs, guard rails and fixed obstructions.
- **CLOSE** Mower door and stop operating if bystanders come within 300 feet of the mower.
- Keep mower door closed when cutting close to the ground.
- Open door only to cut large brush or tree limbs. Close door immediately after cutting limb.
- **DO NOT** push mower head down onto material to cut it, use the front tips of the mower blades to cut into the material.
- **DO NOT** operate mower when mower is in transport position.
- **STOP MOWING** immediately if blades strike heavy objects, fixed structures, metal guard rails and concrete structures:
 1. **BLADES CAN FAIL** from impact and objects can be thrown with great velocity.
 2. **INSPECT** and **REPLACE** any damaged blades.
 3. **CHECK** blade carrier and **REPLACE** if damaged.
- **DO NOT** mow in standing water **TO AVOID** possible **BLADE FAILURE**.
- **AVOID MOWING** in reverse:
 1. **STOP PTO** and back up mower.
 2. **LOWER** mower, engage **PTO** and mow forward.
- **DISENGAGE** mower head and wait until **BLADES** stop rotating before raising mower to transport position.
- **DO NOT ENGAGE PTO** with mower in transport position.
- **STOP** mowing when **EXCESSIVE VIBRATION** occurs:
 1. **STOP PTO** and tractor **ENGINE**.
 2. **INSPECT** mower for vibration source.
 3. **REPLACE** any damage parts and bent or damaged **BLADES**. *PN TOBM-02*

SAFETY

SAFETY

RUN OVER HAZARDS

		
Operator run over hazard	Rider fall off run over hazard	Bystander run over hazard



TO AVOID SERIOUS INJURY OR DEATH FROM FALLING OFF TRACTOR OR EQUIPMENT RUN OVER:

- **USE ROPS** and **SEAT BELT** equipped tractors for mowing operations.
- **KEEP ROPS** locked in **UP** position.
- **ONLY** start tractor while seated in tractor seat.
- **ALWAYS BUCKLE UP** seat belt when operating tractor and equipment.
- **ONLY OPERATE** tractor and equipment while seated in tractor seat.
- **NEVER ALLOW RIDERS** on tractor or implement.
- When not mowing stow Boom and Mower head in transport location before moving.

WHEN MOUNTING AND DISMOUNTING TRACTOR:

- **ONLY** mount or dismount when tractor and moving parts are stopped.
- **STOP ENGINE AND PTO**, engage parking brake, lower implement, allow all moving parts to stop and remove key before dismounting from tractor. *PN ROBM-01*

SAFETY

SAFETY

PTO ENTANGLEMENT HAZARDS

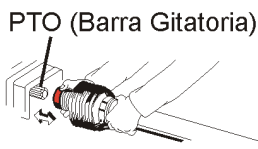
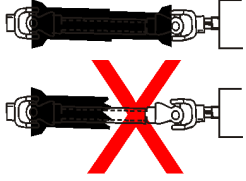
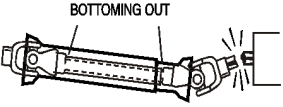
	 <p>PTO (Barra Gitoria)</p>		 <p>BOTTOMING OUT</p>
<p>Entanglement hazard Do Not approach or touch a rotating PTO driveshaft</p>	<p>Make sure PTO shaft is securely attached Do Not Use PTO Adapter</p>	<p>DO NOT Operate if PTO shields are damaged or missing</p>	<p>Make sure PTO shafts are proper length</p>



KEEP AWAY FROM ROTATING DRIVELINES AND ELEMENTS TO AVOID SERIOUS INJURY OR DEATH:

STAY AWAY and **KEEP** hands, feet and body **AWAY** from rotating blades, drivelines and parts until all moving elements have stopped.

- **STOP, LOOK** and **LISTEN** before approaching the mower to make sure all rotating motion has stopped.
- **ROTATING COMPONENTS CONTINUE** to **ROTATE** after the PTO is shut off.

PTO SHIELDING:

TO AVOID SERIOUS INJURY OR DEATH FROM ENTANGLEMENT WHEN OPERATING IMPLEMENT:

- **KEEP PTO** shields, integral driveline shields and input shields installed
- **DO NOT OPERATE** mower without shields and guards in place or missing
- **REPAIR OR REPLACE** if damage, broken or missing
- **ALWAYS REPLACE GUARDS** that have been removed for service or maintenance.
- Do Not use PTO or PTO guard as a step.

TO AVOID broken driveline during operations:

- **CHECK** driveline for proper length between PTO shaft and implement gearbox shaft. *(Refer to Instructions in Operation Section)*
- Drivelines too short can pull apart or disengage.
- Drivelines too long can bottom out.
Bottoming driveline telescoping assembly will stop sliding and become solid.
- Driveline bottoming can push through support bearings and break off PTO shaft
- **AVOID** sharp turns or lift mower to heights to cause driveline "knocking".
- Lubricate driveshaft-telescoping components weekly.





CONTACT DEALER if implement driveline does not match Tractor PTO shaft:

- **DO NOT USE PTO ADAPTER.**

Using a PTO adapter can cause excessive vibration, thrown objects, blade and implement failures by doubling operating speed. Increased working length exposing unshielded driveline areas. **PN PE01**

SAFETY

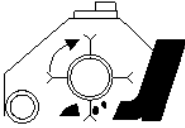
MOWER BLADE CONTACT HAZARDS

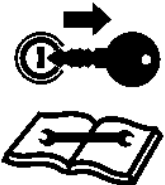
					
Do not put fingers underneath mower	Do not put hands underneath Flail Mower	Do not put foot underneath mower	Do not put foot underneath Flail Mower	Shearing Hazard from Sickle blades	Stop Tractor Remove Key Read Manual



KEEP AWAY FROM ROTATING BLADES TO AVOID SERIOUS INJURY OR DEATH FROM BLADE CONTACT:

- **STAY AWAY** and **KEEP HANDS, FEET** and **BODY AWAY** from rotating blades, drivelines and parts until all moving elements have stopped.
- **DO NOT** put hands or feet under mower decks
- **STOP** rotating **BLADES** disengage mower switch and PTO and wait for blade to stop rotating before raising mower head.
- **DO NOT** approach Sickle Bar head until Tractor Engine has been shut off.
- **STOP LOOK** and **LISTEN** before approaching the mower to make sure all rotating motion has stopped. *PN MBBM-01*

SAFETY

SAFETY

HIGH PRESSURE OIL LEAK HAZARD

			
<p>High pressure oil penetrating skin</p>	<p>High pressure oil eroding skin</p>	<p>Using cardboard to check for oil leaks</p>	<p>Tank contents under pressure. Allow oil to cool before slowly removing cap</p>



TO AVOID SERIOUS INJURY OR DEATH FROM HIGH PRESSURE HYDRAULIC OIL LEAKS PENERATING SKIN:

- **DO NOT OPERATE** equipment with oil or fuel leaks.
- **KEEP** all hydraulic hoses, lines and connections in **GOOD CONDITION** and **TIGHT** before applying system pressure.
- **RELIEVE HYDRAULIC PRESSURE** before disconnecting lines or working on the system.
- **REMOVE** and replace hose if you suspect it leaks. Have dealer test it for leaks.

HIGH PRESSURE FLUID LEAKS CAN BE INVISIBLE.

WHEN CHECKING FOR HYDRAULIC LEAKS AND WORKING AROUND HYDRAULIC SYSTEMS:

- **ALWAYS WEAR** safety glasses and impenetrable gloves.
- **USE** paper or cardboard to search for leaks.
- **DO NOT USE** hands or body parts to search for leak.
- **KEEP** hands and body **AWAY** from pin holes and nozzles ejecting hydraulic fluid.
- Hydraulic fluid may cause gangrene if not surgically removed immediately by a doctor familiar with this form of injury.

Use caution when removing Hydraulic Tank cap.

- Tank contents maybe under pressure
- Allow oil to cool before removing cap.
- Relieve oil pressure before removing cap slowly.
- Stay away from hot oil that may spray from tank.

PN HPBM-01

SAFETY

ELECTRICAL & FIRE HAZARDS

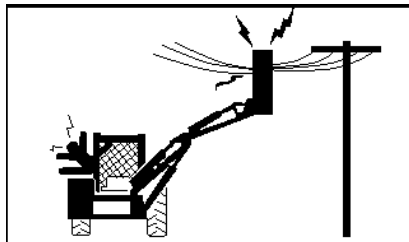

Mower head or Boom contacting overhead electrical lines



Strike and explosion Hazard
Blades Contacting Utility or Gas Lines

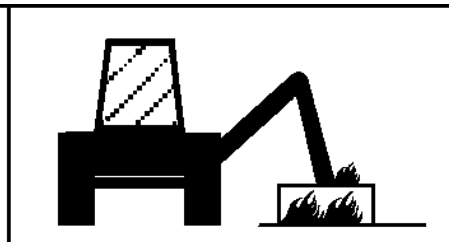

Fire Hazard Do Not operate near fires. Keep debris away from hydraulic pumps and valves



TO AVOID SERIOUS INJURY OR DEATH FROM ELECTRICAL CONTACT WHEN WORKING AROUND ELECTRICAL POWER LINES, GAS LINES AND UTILITY LINES:

- **INSPECT** mowing area for overhead or underground electrical power lines, obstructions, gas lines, cables and Utility, Municipal, or other type structure.
- **KEEP** all raised wings at a 10 feet or greater distance from all power lines and overhead obstructions.
- **DO NOT** allow mower to contact with any Utility, Municipal, or type of structures and obstructions.
- **CALL 811** and 1-800-258-0808 for identify buried utility lines.

FIRE PREVENTION GUIDELINES while Operating, Servicing, and Repairing Mower and Tractor to reduce equipment and grass fire Risk:

- **EQUIP** Tractor with a **FIRE EXTINGUISHER**
- **DO NOT OPERATE** mower on a tractor equipped with under frame exhaust
- **DO NOT SMOKE** or have open flame near Mower or Tractor
- **DO NOT DRIVE** into burning debris or freshly burnt area
- **AVOID FIRE IGNITION** by not allowing mower blade to contact solid objects like metal or rock.
- **DO NOT** operate if oil is leaking. Repair oil leak and remove all accumulated oil before operating.
- **CLEAR** any grass clippings or debris buildup around mower hydraulic pumps, valves or tanks.
- **SHUT OFF ENGINE** while refueling. *PN EFBM-01*

SAFETY

TRANSPORTING HAZARDS

		
<p>Use SMV signs and Flashing Lights</p>	<p>Loss of Control Stopping Hazard</p>	<p>Loss of Control Speeding Hazard</p>

WARNING

TO AVOID SERIOUS INJURY AND DEATH WHEN TOWING OR TRANSPORTING EQUIPMENT:

- **KEEP** transport speed **BELOW** 20 mph to maintain control of equipment.
- **REDUCE SPEED** on inclines, on turns and in poor towing conditions.
- **DO NOT TOW** with trucks or other vehicles.
- **USE** only properly sized and equipped tractor for towing equipment.
- **FOLLOW** all local traffic regulations.

TRACTOR REQUIREMENTS FOR TOWING OR TRANSPORTING IMPLEMENTS:

- **ONLY TRANSPORT** with tractor with **ROPS** in the raised position.
- **USE** properly sized and equipped tractor that exceeds implement weight by at least 20%.
- **KEEP** 20% of tractor weight on front wheels to maintain safe steering.

BEFORE TRANSPORTING OR TOWING IMPLEMENT:

TRACTOR INSPECTION:

- **CHECK** steering and braking for proper operation and in good condition.
- **CHECK SMV** sign, reflectors and warning lights for proper operation and visibility behind unit.
- **CHECK** that your driving vision is not impaired by tractor, cab, or implement while seated in tractor seat.
- **ADJUST** your operating position, mirrors, and implement transport for clear vision for traveling and traffic conditions.

PREPARE IMPLEMENT FOR TRANSPORTING OR TOWING:

- Store Boom and Mower in transport positions and engage transport locks if equipped.

DETERMINE STOPPING CHARACTERISTICS OF TRACTOR AND IMPLEMENT FOR TRANSPORTING OR TOWING:

BRAKING TESTS:

- Stopping distance with implement attached may increase
- Observe **STOPPING** distances increases with increased speeds.
- **DETERMINE** the maximum safe transport speed that does not exceed 20 mph.
- Reduce travel speed in wet or icy roads, stopping distances increase.

DETERMINE MAXIMUM TURNING SPEED BEFORE OPERATING ON ROADS OR UNEVEN GROUND:

- **TEST** equipment in slowly increasing speed in turns to determine it can be operated at higher speeds.
- **USE REDUCED** turning speeds in sharp turns to avoid equipment turning over.

WHEN TOWING OR TRANSPORTING EQUIPMENT:





- Always **WEAR SEAT BELT** when operating or transporting mower.
- **USE** low speeds to avoid overturn with raised wings.
- **USE** low speeds and gradual steering on curves, hills, rough or uneven surfaces and on wet roads.
- **TURN ON** tractor **FLASHING WARNING LIGHTS**.
- **ALLOW** clearance for implement swing while turning.

KEEP raised boom mower 10 feet or greater distance from all power lines and overhead obstructions. *PN THBM-01*

SAFETY

SAFETY

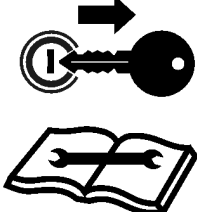
HAZARDS WITH MAINTENANCE OF IMPLEMENT

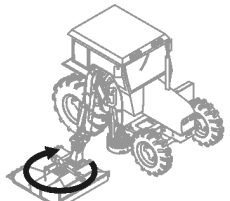
				
Periodically inspect all moving parts, lubricate drivelines, and tighten all fasteners	Lower mower head to ground or block up before servicing	Stop engine remove key before conducting maintenance	Set mower head securely on the ground before servicing blades	Thrown Objects Hazard Ensure blades rotate clockwise viewed from above mower head



AVOID SERIOUS INJURY OR DEATH FROM COMPONENT FAILURE BY KEEPING IMPLEMENT IN GOOD OPERATING CONDITION IN PERFORMING PROPER SERVICE, REPAIRS AND MAINTENANCE.

BEFORE PERFORMING SERVICE, REPAIRS AND MAINTENANCE ON THE IMPLEMENT:

- **STOP ENGINE AND PTO**, engage parking brake, lower implement, allow all moving parts to stop and remove key before dismounting from tractor.
- **PLACE** implement on ground or securely block up raised equipment. Use large blocks on soft or wet soil.
- **PUSH** and **PULL** Remote Hydraulic Cylinder lever to relieve hydraulic pressure.
- **DISCONNECT Pump solenoid valve or PTO driveline connection before servicing mower head.**
- **WEAR SAFETY GLASSES, PROTECTIVE GLOVES** and follow **SAFETY PROCEDURES** when performing service, repairs and maintenance on the implement:
 - Always **WEAR** protective **GLOVES** when handling blades, knives, cutting edges or worn component with sharp edges.
 - Always **WEAR GLOVES** and **SAFETY GLASSES** when servicing hot components
 - **AVOID CONTACT** with hot hydraulic oil tanks, pumps, motors, valves and hose connection surfaces.
 - **SECURELY** support or **BLOCK UP** raised implement, framework and lifted components before working underneath equipment.
 - **FOLLOW INSTRUCTIONS** in maintenance section when replacing hydraulic cylinders to prevent component falling.
 - **STOP** any implement movements and **SHUT-OFF TRACTOR** engine before doing any work procedures.
 - **USE** ladder or raised stands to reach high equipment areas inaccessible from ground.
 - **ENSURE** good footing by standing on solid flat surfaces when getting on implement to perform work.
 - **FOLLOW** manufacturer's instructions in handling oils, solvents, cleansers, and other chemical agents.
 - **DO NOT** change any factory-set hydraulic calibrations to avoid component or equipment failures.
 - **DO NOT** modify or alter implement, functions or components.
 - **DO NOT WELD** or repair rotating mower components. These may cause vibrations and component failures being thrown from mower.

PERFORM SERVICE, REPAIRS, LUBRICATION AND MAINTENANCE OUTLINED IN IMPLEMENT MAINTENANCE SECTION:

- **INSPECT** for loose fasteners, worn or broken parts, leaky or loose fittings, missing or broken cotter keys and washers on pins, and all moving parts for wear.
- **REPLACE** any worn or broken parts with authorized service parts.
- Inspect mower blade spindle to ensure bearing preload. If loose repair before operating.
- **LUBRICATE** unit as specified by lubrication schedule
- **NEVER** lubricate, adjust or remove material while it is running or in motion.
- **TORQUE** all bolts and nuts as specified.

BLADE INSPECTION:

- Inspect blade carrier and blades daily.
- Check blade and blade carrier **BOLT TORQUE** daily. Loose bolts can cause blade or blade bolt failures.
- **REPLACE**, bent, damage, cracked and broken blades immediately with new blades.
- **AVOID** blade failures and thrown broken blades. **DO NOT** straighten, weld, or weld hard-facing blades.

SAFETY SHIELDS, GUARDS AND SAFETY DEVICES INSPECTION:

- **KEEP** all Deflectors, Chain Guards, Steel Guards, Gearbox Shields, and PTO integral shields, Bands, Side Skirts and Skid Shoes in place and in good condition.
- **REPLACE** any missing, broken or worn safety shields, guards and safety devices.
- Engine Exhaust, some of its constituents, and certain vehicle components contain or emit chemicals known to the state of California to cause cancer, birth defects or other reproductive harm.
- Battery posts, terminals and related accessories contain lead and lead compounds, chemicals known to the state of California to cause cancer, birth defects or other reproductive harm. **PN HMBM-01**

SAFETY

SAFETY

PARTS INFORMATION

PARTS INFORMATION

Tiger mowers use balanced and matched system components for blade carriers, blades, cuttershafts, knives, knife hangers, rollers, drivetrain components, and bearings. These parts are made and tested to Tiger specifications. Non-genuine "will fit" parts do not consistently meet these specifications. The use of "will fit" parts may reduce mower performance, void mower warranties, and present a safety hazard. Use genuine Tiger mower parts for economy and safety. (SPTM-1)

SEE YOUR TIGER DEALER

Operator's & Parts Manuals



www.algqr.com/tpm

SAFETY

SAFETY

SAFETY

Decal Location

NOTE: Tiger supplies safety decals on this product to promote safe operation. Damage to the decals may occur while in shipping, use, or reconditioning. Tiger cares about the safety of its customers, operators, and bystanders, and will replace the safety decals on this product in the field, free of charge (Some shipping and handling charges may apply). Contact your Tiger dealer to order replacement decals.

Boom Arm

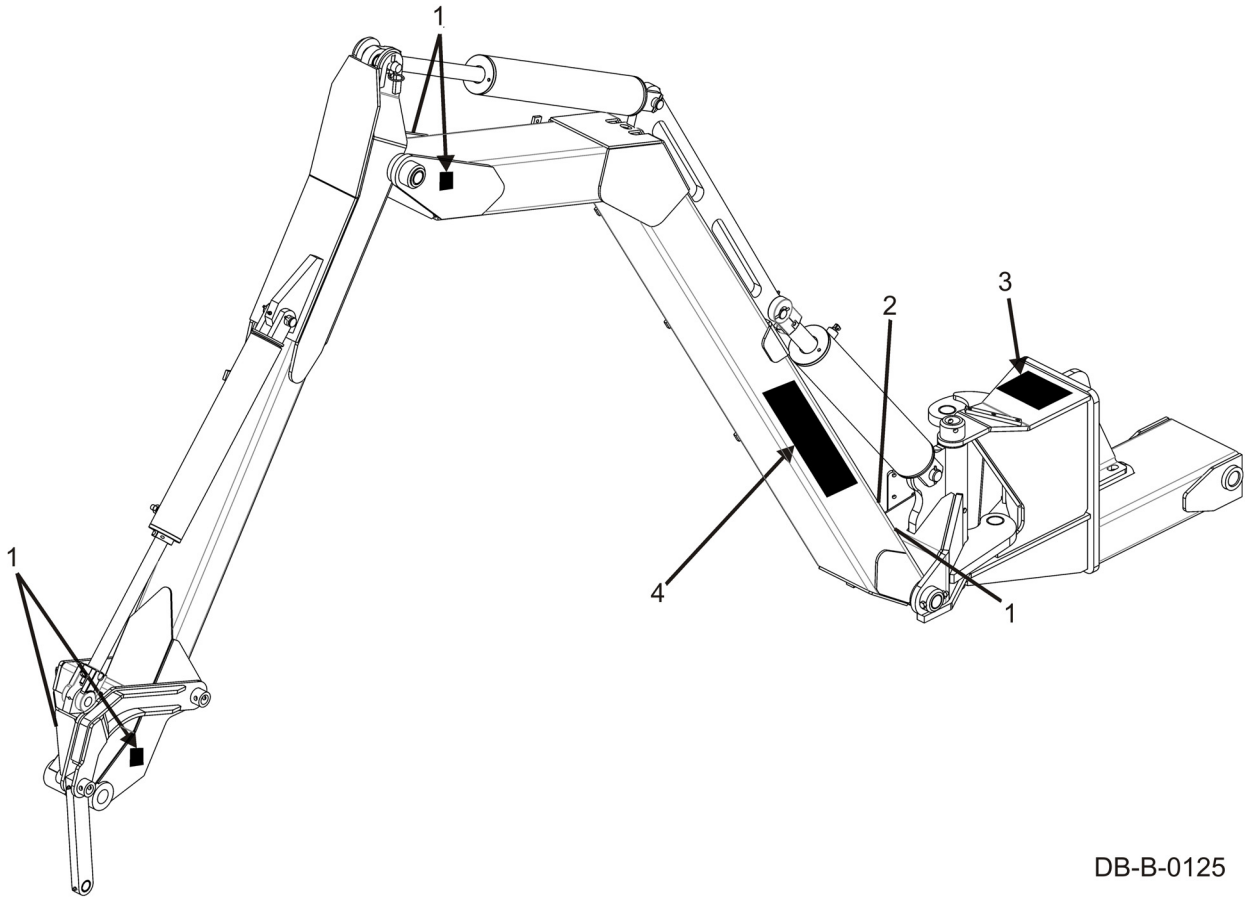

DB-B-0125

ITEM	PART NO.	QTY.	TYPE	DESCRIPTION
1.	02962764	5	WARNING	Pinch Points
2.	02965262	1	WARNING	Hydraulic Oil Hazard
3.	02962765	1	DANGER	Crushing Hazard
4.		1	LOGO	Name

SAFETY

50" & 60" Rotary

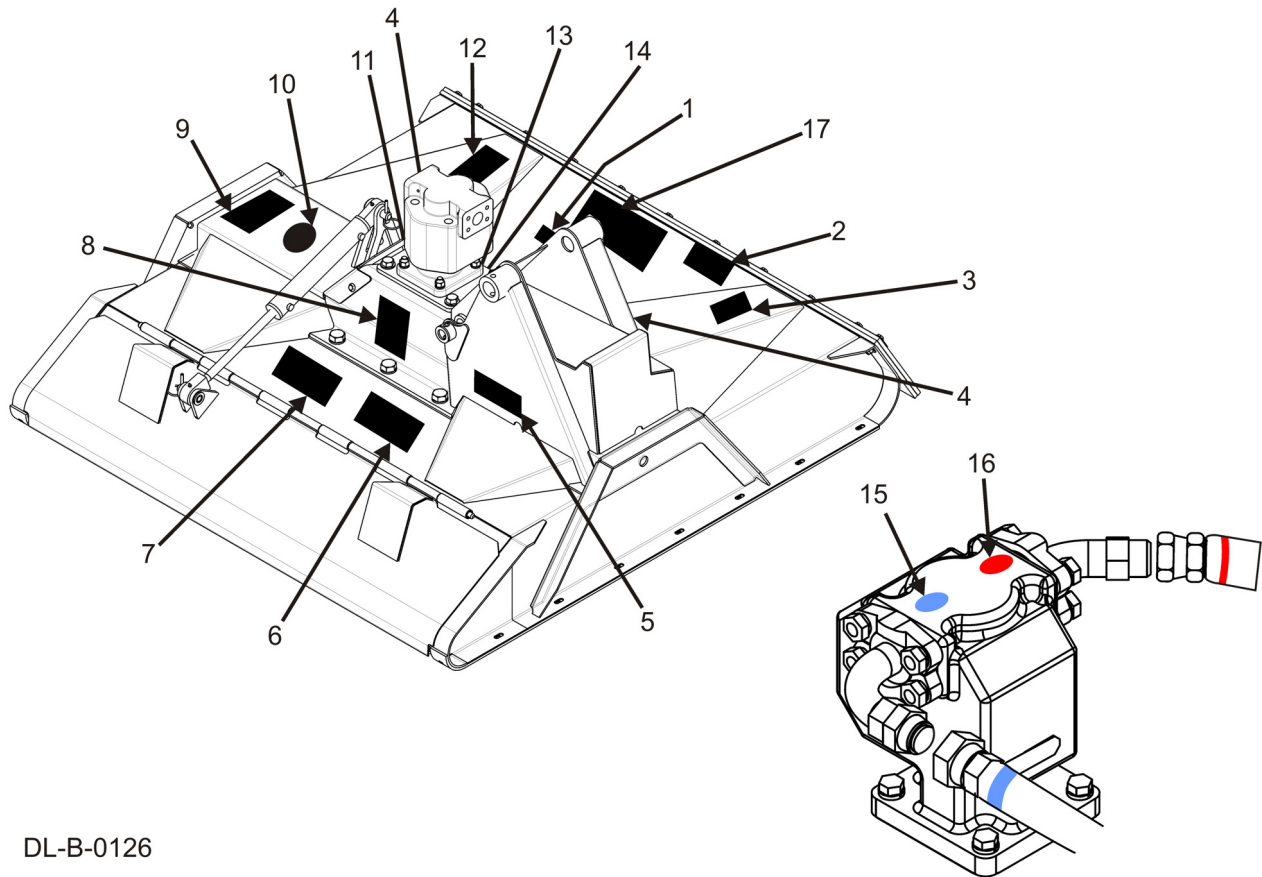

DL-B-0126

ITEM	PART NO.	QTY.	TYPE	DESCRIPTION
1.	6T3237	1	WARNING	Replace Blades
2.	24028	1	WARNING	Thrown Object Hazard
3.	D637	1	WARNING	Disconnect Hydraulic Solenoid
4.	42399	2	REFLECT	Red Reflector
5.	4240006	1	REFLECT	Amber Reflector
6.	D668	1	INSTRUCT	Lubrication Chart
7.	33224	1	DANGER	Blades, Thrown Object
8.	D619	1	WARNING	Blade Rotation
9.		1	LOGO	Made in the USA
10.		1	LOGO	Tiger Genuine Parts
11.	22839	1	INSTRUCT	Use Hand Grease Gun
12.	32709	1	WARNING	Use Genuine Tiger Parts
13.	6T3221	1	INSTRUCT	Lubrication Instructions
14.	nfs	1	SERIAL PLATE	Serial Number Plate
15.	06550058	1	INSTRUCT	Blue Dot
16.	06550057	1	INSTRUCT	Red Dot
17.		1	LOGO	Name

BOOM

Safety Section 1-17

SAFETY

SAFETY

50" & 63" Flail

SAFETY

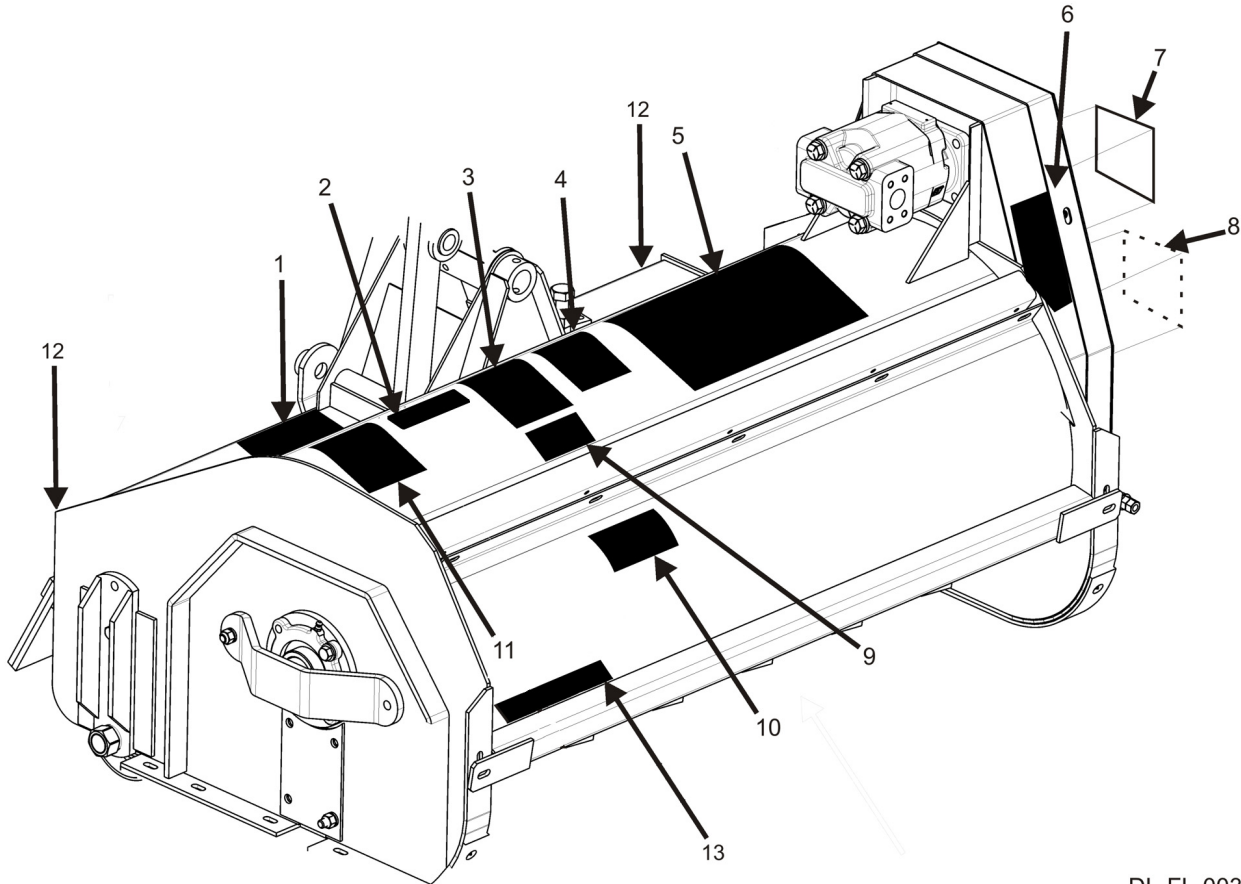

DL-FL-0031

ITEM	PART NO.	QTY.	TYPE	DESCRIPTION
1.	24028	1	DANGER	Thrown Object Hazard, Deflectors
2.	32709	1	WARNING	Use Genuine Tiger Parts
3.	33224	1	DANGER	Blades, Thrown Object
4.	D637	1	WARNING	Disconnect Hydraulic Solenoid
5.		1	LOGO	Tiger Logo
6.	00758194	1	WARNING	Pinch Point Hazard
7.		1	LOGO	50" Logo
		1	LOGO	63" Logo
8.	D646	1	DANGER	Guard Missing, Do Not Operate
9.	D655	1	INSTRUCT	Lube Chart
10.	TB1011	1	DANGER	Thrown Object Hazard, Shield
11.	6T3236	1	LOGO	Made in the USA
12.	42399	2	REFLECT	Red Reflector
13.	4240006	1	REFLECT	Amber Reflector
14.	nfs	1	SERIAL PLATE	Serial Number Plate

SAFETY



WARNING

TO AVOID SERIOUS INJURY OR DEATH FROM HIGH PRESSURE HYDRAULIC OIL LEAKS PENETRATING SKIN:

- DO NOT OPERATE equipment with oil or fuel leaks.
- KEEP all hydraulic hoses, lines and connections in good condition and tight before applying system pressure.
- Relieve hydraulic pressure before disconnecting lines or working on the system.
- REMOVE and replace hose if you suspect it leaks. Have dealer test it for leaks.

HIGH PRESSURE FLUID LEAKS CAN BE INVISIBLE. WHEN CHECKING FOR HYDRAULIC LEAKS AND WORKING AROUND HYDRAULIC SYSTEMS:

- DO NOT use hands to check for leaks.
- ALWAYS WEAR safety glasses and impenetrable gloves.
- USE paper or cardboard to search for leaks.
- KEEP hands and body AWAY from pin holes and nozzles ejecting hydraulic fluid.
- Hydraulic fluid may cause gangrene if not surgically removed immediately by a doctor familiar with this form of injury.

02965262

DANGER

CRUSHING AND PINCH POINTS

MOVING MACHINERY PARTS CAN PINCH OR CRUSH OR FALL-WHICH MAY CAUSE INJURY OR DEATH.

02962765

SAFETY

SAFETY

SAFETY

⚠ DANGER

THROWN OBJECT HAZARD

TO AVOID SERIOUS INJURY OR DEATH:
DO NOT OPERATE if Thrown Object Shielding is damaged or missing.

- Maintain Rubber Deflectors in good condition.
- Inspect Rubber Deflectors frequently.

MAINTAIN Thrown Object Shielding

HERE



24028



Rubber Deflector

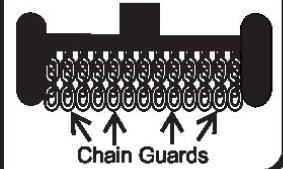

Chain Guards

⚠ WARNING

TO AVOID SERIOUS INJURY OR DEATH FROM INADVERTENT MOWER HEAD START UP:

- Disconnect the hydraulic solenoid BEFORE servicing the tractor or mower.

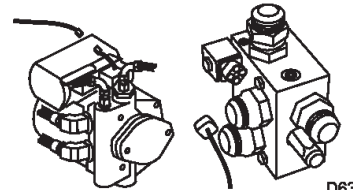

D637

⚠ WARNING

TO AVOID SERIOUS INJURY OR DEATH FROM BLADE ATTACHMENT FAILURE:

- Torque 1-1/8" blade bolt to 800 ft lbs.
- ALWAYS replace blades in pairs.
- ALWAYS replace blades with new bolts and nuts.

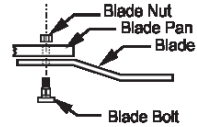

Blade Nut
Blade Pan
Blade
Blade Bolt

6T3237

⚠ WARNING

TO AVOID SERIOUS INJURY AND DEATH FROM THROWN OBJECTS:

- MAKE CERTAIN blades rotate the correct direction.

BLADE ROTATION



D619

Gear Motor **Piston Motor**

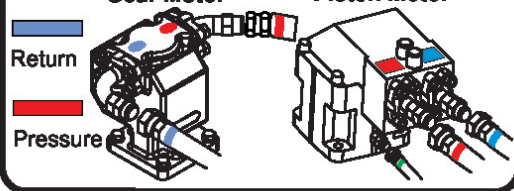

Return
Pressure

SAFETY

SAFETY

⚠ DANGER		
		
THROWN OBJECTS HAZARD		
<p>Mower can throw objects up to 300 feet. TO AVOID SERIOUS INJURY OR DEATH to operator or bystanders:</p> <ul style="list-style-type: none">● CLOSE MOWER DOOR and STOP operating if bystanders or traffic come within 300 feet.● KEEP door fully closed when cutting grass and weeds.● OPEN door ONLY to cut large brush. Close door immediately after.● DO NOT operate with door removed.● KEEP door in place and in good condition during operation.● Deflectors are SUBJECT TO WEAR. Replace if worn or damaged.● ALWAYS transport with door closed. 33224		
ENTANGLEMENT HAZARD		
	<ul style="list-style-type: none">● STAY AWAY and KEEP hands, feet and body AWAY from rotating blades, drivelines and parts that continue to move after power shut-off. WAIT until all moving elements have stopped.● STOP, LOOK and LISTEN for rotating motion before approaching implement.	

SAFETY

SAFETY

⚠ WARNING

Non-genuine parts can fail catastrophically. TO AVOID SERIOUS INJURY OR DEATH:

- ONLY use genuine TIGER replacement parts.
- Non-genuine parts can fail creating hazardous conditions for operator and bystanders.

Contact local dealer or TIGER about repair parts at:

3301 N. LOUISE AVE.,
SIOUX FALLS, SD 57107 www.algqr.com/tpm
Customer Service: 800-843-6849.
Email: feedback@tiger-mowers.com 32709 1



IMPORTANT

BE AWARE BE TRAINED
BE ALERT Before Operating this Mower
BE ALIVE

To prevent serious injury to yourself and/or bystanders, be trained in Safe Mowing Practices. Alamo Group Companies as well as AEM and FEMA provide training material that is critical for your Safety and the Safety of others when operating this equipment. www.algqr.com/tbv

Make these Safety Procedures an important part of every workday. Read and understand the Operator's Manual. Do not let untrained individuals operate this equipment. Contact your Dealer, AEM (www.aem.org), FEMA (314-878-2304, www.FarmEquip.org), or Alamo Group (www.Alamo-Group.com) for information on training material or courses that provide training in Safer Operating Practices for Mowers. 32709 2 32709



SAFETY

SAFETY

⚠ WARNING	
PINCH POINT HAZARD	
TO AVOID SERIOUS INJURY: <ul style="list-style-type: none">• DO NOT OPERATE with Belt Shield removed.	
00758194	

⚠ DANGER

D646
GUARD MISSING DO NOT OPERATE

⚠ DANGER	
THROWN OBJECTS HAZARD	
Mower can throw objects up to 300 feet. TO AVOID SERIOUS INJURY OR DEATH to operator or bystanders: <ul style="list-style-type: none">• DO NOT operate with Shield removed.• KEEP Shield in place and in good condition during operation.	
Tb1011	

SAFETY

Federal Laws and Regulations

This section is intended to explain in broad terms the concept and effect of federal laws and regulations concerning employer and employee equipment operators. This section is not intended as a legal interpretation of the law and should not be considered as such.

Employer-Employee Operator Regulations

U.S. Public Law 91-596 (The Williams-Steiger Occupational and Health Act of 1970) OSHA

This Act Seeks:

“...to assure so far as possible every working man and woman in the nation safe and healthful working conditions and to preserve our human resources...”

DUTIES

Sec. 5 (a) Each employer-

- (1) shall furnish to each of his employees employment and a place of employment which are free from recognized hazards that are causing or are likely to cause death or serious physical harm to his employees;
- (2) shall comply with occupational safety and health standards promulgated under this Act.
- (b) Each employee shall comply with occupational safety and health standards and all rules, regulations and orders issued pursuant to this Act which are applicable to his own actions and conduct.

OSHA Training Requirements

Title 29, Code of Federal Regulations Part 1928.57(a)(6). www.osha.gov

Operator instructions. At the time of initial assignment and at least annually thereafter, the employer shall instruct every employee who operates an agricultural tractor and implements in the safe operating practices and servicing of equipment with which they are or will be involved, and of any other practices dictated by the work environment.

Keep all guards in place when the machine is in operation;

Permit no riders on equipment

Stop engine, disconnect the power source, and wait for all machine movement to stop before servicing, adjusting, cleaning or unclogging the equipment, except where the machine must be running to be properly serviced or maintained, in which case the employer shall instruct employees as to all steps and procedures which are necessary to safely service or maintain the equipment.

Make sure everyone is clear of machinery before starting the engine, engaging power, or operating the machine.

Employer Responsibilities:

To ensure employee safety during Tractor and Implement operation, it is the employer's responsibility to:

1. Train the employee in the proper and safe operation of the Tractor and Implement.
2. Require that the employee read and fully understand the Tractor and Implement Operator's manual.
3. Permit only qualified and properly trained employees to operate the Tractor and Implement.
4. Maintain the Tractor and Implement in a safe operational condition and maintain all shields and guards on the equipment.
5. Ensure the Tractor is equipped with a functional ROPS and seat belt and require that the employee operator securely fasten the safety belt and operate with the ROPS in the raised position at all times.
6. Forbid the employee operator to carry additional riders on the Tractor or Implement.
7. Provide the required tools to maintain the Tractor and Implement in a good safe working condition and provide the necessary support devices to secure the equipment safely while performing repairs and service.
8. Require that the employee operator stop operation if bystanders or passersby come within 300 feet.

Child Labor Under 16 Years of Age

Some regulations specify that no one under the age of 16 may operate power machinery. It is your responsibility to know what these regulations are in your own area or situation. (Refer to U.S. Dept. of Labor, Employment Standard Administration, Wage & Home Division, Child Labor Bulletin #102.)

5 GG9 A 6 @ MG9 7 HCB

5 GG9 A 6 @M

6 YZcfY UHya dh]b['lc'a ci bhnci f' H][Yf'a ck Yfž]h]g]a dcfhUbh
lc'fYUX'UbX'i bXYfghUbX' U``cZ R Y' gUZymia YggU[Yg']b'R Y'GUZym
GYW]cb'cZK]g'a Ubi U"

Check complete shipment list against the packing list to make sure there are no shortages. Make certain the tractor model is the appropriate one for the mower received!



Always use a floor jack, hoist or fork lift to lift and raise heavy parts.

Read and understand the entire Assembly Section instructions before attempting to mount your Tiger mower. Refer to the Parts Section of this manual for detailed illustrations to locate all parts. (ASM-C-0001)

HF 5 7 HCF 'DF 9 D5 F 5 HCB

- A. Remove right and left hand steps.
- B. Disconnect battery cables from both batteries.
- C. Remove engine side panels, or raise hood to access front pulley.
- D. Remove plugs from tractor casting where mainframe and pump mount will be attached.
- E. Remove any front weights and weight supports.
- F. Raise the tractor onto jack-stands and remove the right and left rear wheels.

(ASM-C-0024)

7 F 5 B? G<5 : H'5 8 5 DH9 F

If necessary, remove the four capscrews from the crankshaft pulley. Then install the crankshaft adapter to the pulley with capscrews and lockwashers as shown in the Parts Section.

(ASM-NH-0050)



5 GG9 A 6 @M

HG* '0/L'L'H(: '6 5 HH9 F MF 9 @C7 5 H-CB

Installation of the pump driveshaft requires that the battery be raised to allow the driveshaft to pass beneath it from the crankshaft adapter to the pump. Disconnect and remove the battery from the well in the front of the tractor. Place the battery relocation assembly #06370267 in the battery well and secure through the bottom of the tractor casting as shown in the Parts Section. Run capscrew #21332 through the hole in the rear of the bottom level of relocation assembly #06370267 using insulated washers #06510260 above and below. Run new battery cable #06510299 from positive post on battery to capscrew. Connect new positive battery post to capscrew. Connect the existing positive battery cable to the new post. Use the battery strap, cap-screws, flatwashers and u-nuts provided to secure the battery to the relocation assembly. See the Battery Relocation page in the Parts Section for more information.

(ASM-NH-152 BATTERY TS6 1xx T4B)

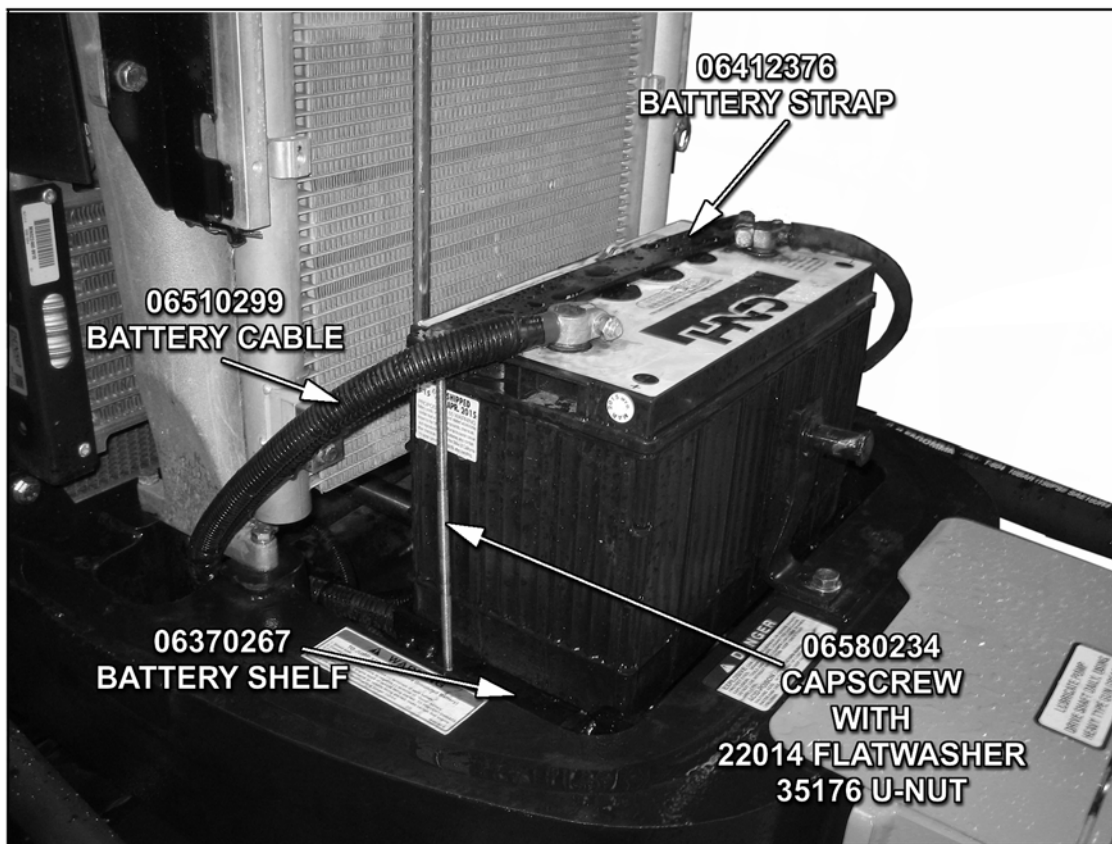

5 GG9 A 6 @M

HG* '0%LL'H(: '7CC@F'<=B; 9'F9D@579A9BH

Installation of the pump driveshaft requires that the hinge on the tractor cooler be replaced to allow the driveshaft to pass beneath it from the crankshaft adapter to the pump. Remove the hinge mount and pin and replace with the Tiger hinge mount (#06412375) and pin (#06420188) provided. (ASM-NH-152 COOLER HINGE TS6 1xx T4B)

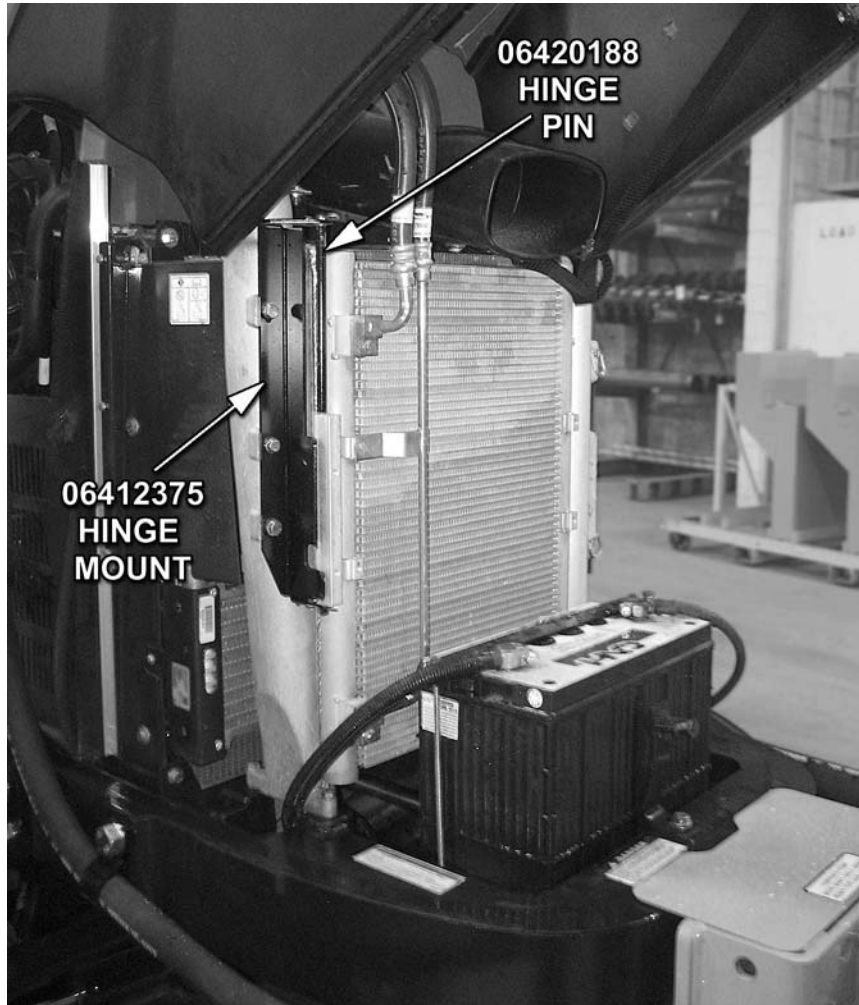

5 GG9 A 6 @M

: FCBH'DI AD'ACI BH-B;

Install the pump mounting bracket on the front of the tractor with capscrews and washers as shown in the Parts Section illustration. DO NOT tighten fasteners at this time.

Thread the pump driveshaft into the crankshaft adapter. The end with the splines should match up with the coupler.

Slide the splined drive shaft coupler onto the pump driveshaft. Install the pump onto the mounting bracket. NOTE: The shaft is offset to one direction, the pump should be installed with the offset side on top. Install hardware for securing pump to the pump mount, DO NOT tighten.

Align pump so that splined coupling can be moved back and forth by hand. Tighten pump mounting bolts in succession, rechecking for spline coupling movement. Remove the pump mounting bracket bolts one at a time and apply a thread locking agent. Tighten these bolts in succession, again checking for free movement in the driveshaft. After all bolts are torqued, the end play on the driveshaft should be 1/16" to 1/8", and the coupler should move freely with hand pressure. If end play is less than 1/16", grind the end of the shaft to achieve the proper end play. If there is more than 1/4" of end play, return the shaft with specifications for a longer shaft.

7 5 I H-CB. 8 C' B C H' G H 5 F H' H < 9' H F 5 7 H C F' I B H @ 5 @ @ < C G 9 G' 5 F 9' 5 H H 5 7 < 9 8 Z H 5 B ?
-G': = @ @ 8 ' K H < ' D F C D 9 F ' C = @ 5 B 8 ' 6 5 @ @ J 5 @ 9 G' 5 F 9' C D 9 B ' ' ' G H 5 F H B ; ' 5 H' H < - G' H A 9
K = @ @ 7 5 I G 9 ' G 9 F - C I G' 8 5 A 5 ; 9' H C' H < 9' D I A D" (ASM-NH-0024)

5 8 > I G H-B; ' F 9 5 F ' K < 9 9 @ G

Raise rear of tractor onto jack-stands. : c `` c k ' h Y] b g l f i W] c b g '] b ' h Y h U W t f ' c k b Y f @
a U b i U ' Z f ' U X 1 g h] b [' h f Y g ' U b X f] a g ' to 72" center for side mounted mowers and 79.8" for boom mowers. NOTE: This may require switching the wheels to opposite sides of tractor. Also take note of any width restrictions when transporting by trailer. (For ease of installation, it is best to leave the rear wheels removed during installation of the mower.) (ASM-NH-0051)



5 GG9 A 6 @M

DC @M7 5 F 6 CB5H9 'G5 : 9HMK -B8 CK

NOTE: Installing a boom mower requires that all of the right side windows be replaced, or protected with a polycarbonate window. This should be done before mounting the mainframe.

1. Disconnect gas shock at door. Remove the right side cab door/window glass from tractor cab by removing hinge pins. Also, remove rear right side window.
2. Remove the existing hardware, door handle and bar handle and discard factory glass door and window.
3. Place small bead of adhesive seal in the bottom of the trim lock bubble seal.
4. Install trim lock bubble seal on polycarbonate starting at the center bottom horizontal portion.
5. Install existing hardware removed from glass door and window on the polycarbonate.
6. Install the polycarbonate assembly in the cab with existing and supplied hardware as shown in the Parts Section.
7. Assemble corner bracket to the control stand inside the cab.
8. Locate and drill a $\text{Ø}1/4$ " hole through polycarbonate, with a bit that is **cb`m**used for polycarbonate, to match the corner bracket.
9. Assemble the bracket and tighten the hardware to secure the polycarbonate.
10. Assemble the clamp in the upper front corner by the mirror.
11. Adjust the clamp to achieve a secure hold.
12. Replace the rear corner window with the hardware removed from the window.

(ASM-NH-0101)

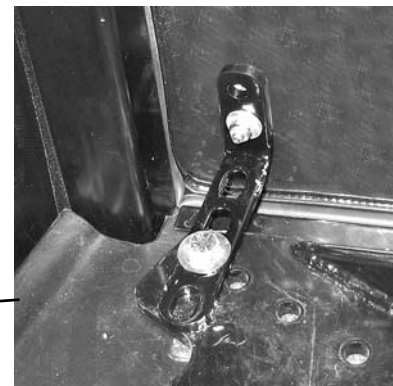

INSIDE
VIEW



5 GG9 A 6 @M

B< 'HG* '%I 'H(6 `: 9B89F'7I H

Installation of the wheel well tank requires modification of the left fender, as shown below. Before cutting the fender, mask the uncut area to prevent scratches. Cut to the approximate size shown below. After cutting TrimLock may be applied to the edges. (ASM-NH TS6 130 FENDER CUT



A5-B: F5 A9-BGH5 @HCB

NOTE: Before installing the axle braces, upright and mainframe, remove the left hand steps. Loosen the fuel tank and slide out two or three inches to provide space to install the left upright plate.

With an overhead hoist and / or jack-stands, raise one side of the frame up to the correctly matching mounting holes. Install capscrews and other hardware to secure the sides of the mainframe to the tractor casting, as shown on the tractor mount kit page in the Parts Section. DO NOT tighten at this time. Remove the capscrews one at a time and apply a thread locking agent. Reinsert the capscrews and tighten / torque to values noted in the torque chart located in the Maintenance Section of this manual. (ASM-NH Mainframe Installation TS6 1xx T4F)



5 GG9 A 6 @M

>CMGH7 ? GK #H7 <6 CL 'A CI BHB;

The switchbox is to be secured to the joystick/switchbox stand. Refer to the Parts Section for assembly and components needed. (ASM-NH-0137 TS6 1XX T4B)



5 GG9 A 6 @M

GK #7 <6 CL 'K #B;

Power and ground are pulled from the tractor's accessory socket using the keyed hot wire on the supplied plug for power and the black wire for ground. Use a test light to verify whether the red or orange wire is the hot wire (hot when key is in the "on" position).

The switchbox is to be secured to the cable control bracket as shown in the Parts Section.

(ASM-NH-0121 TS6 1XX T4B)



5 GG9 A 6 @M

B< 'HG* '0% I 'H(6 'GK 5 M6 5 F '5 F A G

The sway bar arms on the TS6.1xx T4B need to be repositioned. The sway bar anchor should be rotated 180° on its longitudinal axis to place the pin stowage tang outboard. (ASM-NH TS6 130 SWAY BAR ARMS)



5 GG9 A 6 @M

@ H'J5 @J9 'ACI BH-B;

The lift valve mounting bracket and plate will be mounted on legs secured to the rear of the axle braces. See the Parts Section for details on mounting information and hardware used.

(ASM-NH-0066 NH T6 1XX T4F)



5 GG9 A 6 @M

<CG9 FCI HB;

The lift valve uses the tractor's pressure, return and load sense ports. The pressure and return ports are located at the rear of the tractor, below the installed lift valve mount. The load sense port is located beneath the tractor cab. (ASM-NH TS6 1XX T4F HOSE ROUTING)

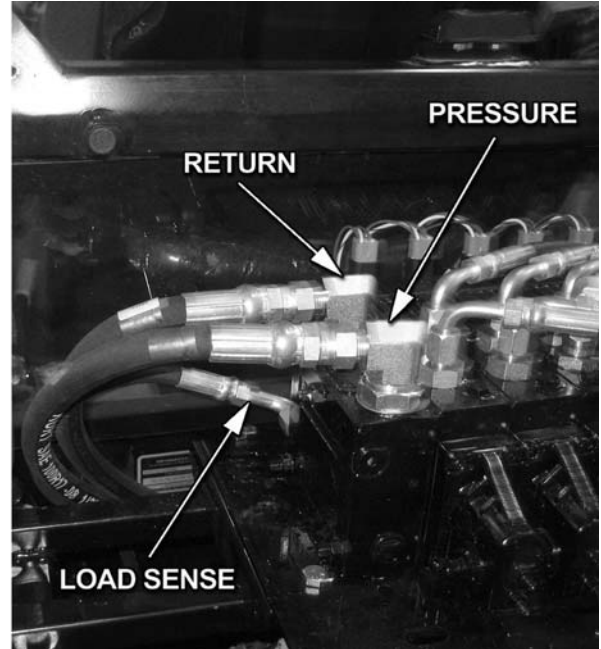
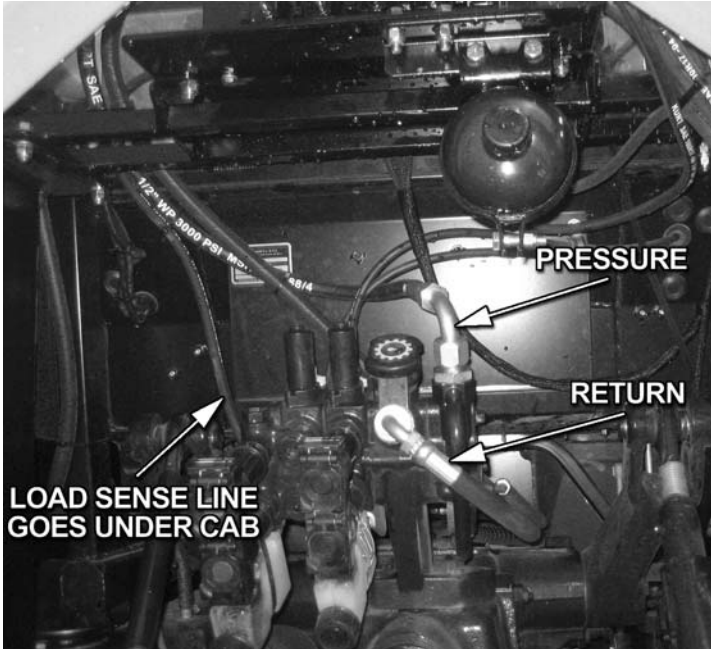

: =@B; <M8 F5I @7 F9 G9 FJC=F

Refer to the Maintenance Section for filling specifications and hydraulic oil requirements.

BCH9. GHUhb['cf'fi bb]b['mci f'H][Yf' a ck Yf' VYZfY'Z'']b['fYgYfj c]f'k]''WU gY gYf]ci g'XUa U Y'lc'h Y\ mXfU ']Wdi a d"

(ASM-C-0004hydro resrv)

=BGH5 @B; 'C!F=B; ': =HHB; G

Installing straight, 45° and 90° O-rings requires that the O-ring and washer be up against the swivel body. Insert the swivel and turn in until the swivel is pointed in the desired direction and O-ring contact is made. Hold swivel in set direction with a wrench and turn the O-ring nut away from the swivel body and carefully tighten. (ASM-C-0056)

=BGH5 @B; 'B5HCB5 @D=D9': =HHB; G

Whenever installing a pipe fitting, wrap the threads clockwise (looking at the end) with teflon tape. In this way, the tape will be tightened when installed. NOTE: It is not necessary to tape O-ring fittings, or those installed in swivels. (ASM-C-0088)



5 GG9 A 6 @M

; 9B9F5 @< CG9 'BGH5 @@5HCB

Refer to the Parts Section for detailed information about hoses and fittings for this application. (ASM-C-0011)

DF9: CFA98 'HI 69 'BGH5 @@5HCB

Lay booms on floor so that the side with the clamp plates is up. Locate all tube clamps and install them loosely onto the clamp plates.

Arrange the tubes and hoses as outlined in the Common Parts Section. Install the tubes closest to the boom arm first, being careful not to pinch the tubes. Place the other tubes outside of the first tubes. Snug all clamp bolts, but do not tighten. Check all tubes for correct alignment and that none are pinched or bent. The clamp bolts can now be tightened. (ASM-C-0085)

577I AI @5HCF 'BGH5 @@5HCB

Install the accumulator bracket on the right mainframe mast or lift valve mount, if applicable, with the capscrews, lockwashers and spacers, if applicable, as shown in the Parts Section. Install the accumulator in the bracket and secure with the hardware shown. Install fittings and hoses to the cylinder and control valve as shown in the Parts Section. I gY'HZcb'UdY'cb'U'' d]dY'Z[h]b[g'fM WdhC!f]b[gL" (ASM-C-0012)

GC @ BC-8 '6 F5 ?9 'J5 @9

Install a solenoid valve on the mounting bracket with the supplied hardware as shown in the Parts Section in this manual. While installing the fittings to the brake valve, the electrical coil on the spool may have to be removed to make room. When reinstalling the coil, it is important to use no more than 5 ft. lbs. (or 60in. lbs.) torque. K 5 FB-B; . 'CJ9F 'HCFEI 9 'HC 'H< 9 '7 C=@ K =@@F9GI @H'B'<M8F5I @7 : 5=@ F9'C: 'GDCC@ (ASM-C-0025)



5 GG9 A 6 @M

@: H'J5 @9' <CG9' 5 B8' 7 5 6 @' FCI HB;

Attach two clamps to the right rear wheel well for proper hose/cable routing. Drill one hole for each clamp. Use the lower rear corner of the wheel well as an origin for measuring. The holes should be $\varnothing 10\text{mm}$ or $\varnothing 3/8''$ reamed to accept $3/8''$ hardware.

Measure from the back edge of the wheel well $13\text{-}1/2''$ from the origin. Use a square to measure $3\text{-}1/2''$ up. Refer to the images below to see the first hole placement.

The second hole should run parallel to the bottom edge of the wheel well. Mark the hole $12''$ from the first hole and $3\text{-}1/2''$ from the bottom edge. Use the images below for reference.

BCH9. 8C' BCH'7I H-BHC' HI 69G'#<CG9G'#K F9G'K <9B'8F=@@B; H<FCI ; <'A9H5 @
.....CF'D@GH7°

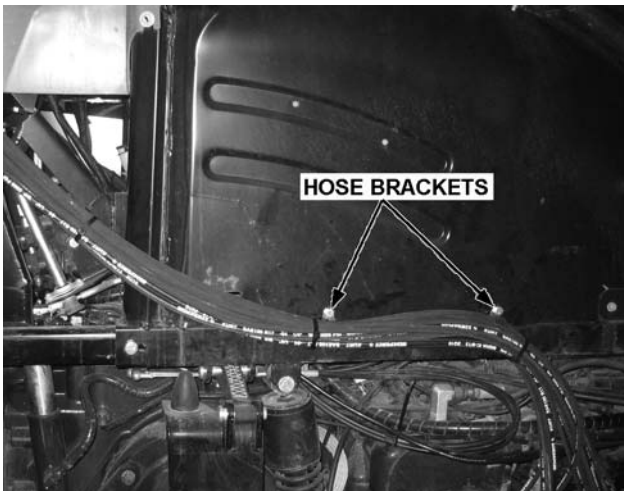

RIGHT REAR FENDER

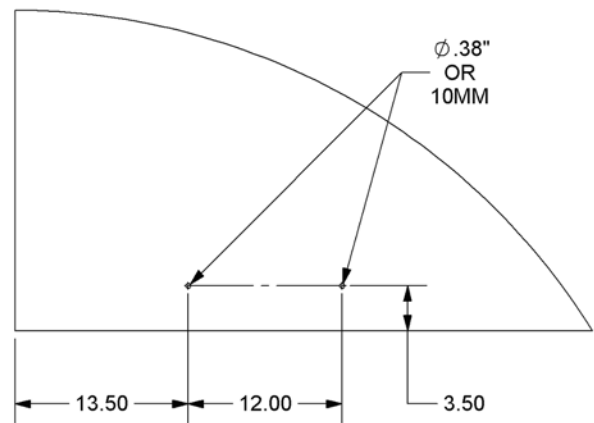

Place as many hoses in the clamp as will fit without compromising pressure. Then secure the (2) HOSE CLAMP (06520013) to the holes drilled with (1 EACH) CAPSCREW, $3/8''$ X $1''$, NC (21630) and (1 EACH) NYLOCK NUT, $3/8''$, NC (21627). The hoses that don't fit into the clamp are to be secured to the others with zip ties. For protection of hoses in contact with metal edges, wrap hoses with split hose sections and fasten with hose clamps or zip ties as needed.

(ASM-NH-0067)



5 GG9 A 6 @M

(ASM-C-0023)

BOOM HYDRAULIC DIAGRAM

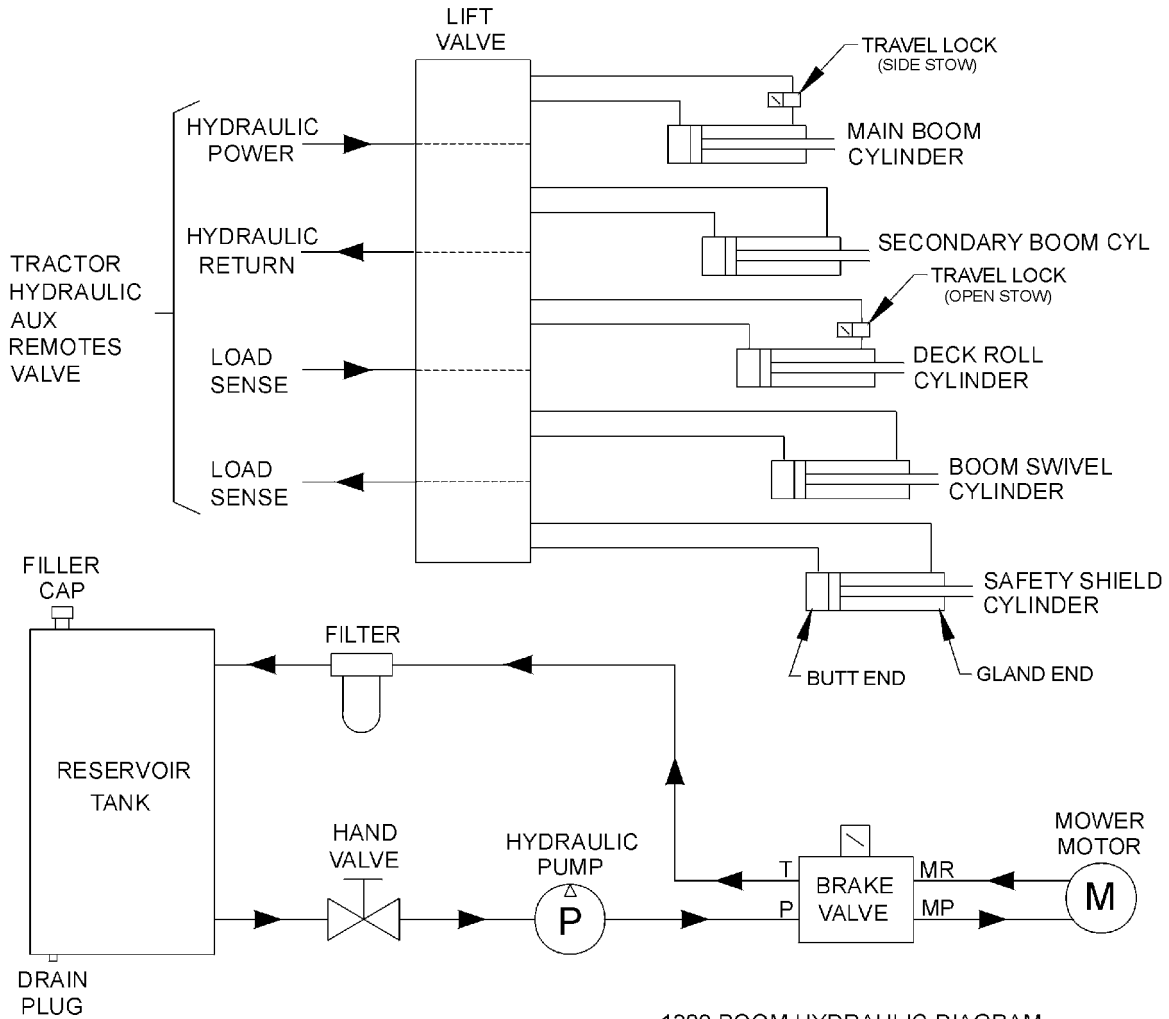

1320 BOOM HYDRAULIC DIAGRAM

K <99 @K 9 @@<M8 F 5 I @7 'H5 B? -BGH5 @5 HCB

Install all fittings and tubes into tank and tank filter as shown in the Parts Section illustration. Insert tank sight glass onto the tractor side of the tank.

Place the tank in the mounting bracket on the axle brace as shown in the Parts Section. Secure the tank with the hardware provided.

Install the filter gauge into the filter housing so that it points to the rear of the tractor and is clearly visible to the operator. The tank breather cap is ready for use as the tank is filled. Some of these items may already be installed. (ASM-C-0103)



5 GG9 A 6 @M

H9 A D9 F 5 H I F 9 ; 5 I ; 9 A C I B H B ; (OPTIONAL)

Mount the temperature gauge where it is clearly visible to the operator. Attach the green (-) wire from the negative post on the gauge to a grounded bolt on the tractor frame. Remove paint if needed to make a good ground. Remove the pipe plug from the side of the hydraulic reservoir and install the temperature sensor using thread sealing tape. Run the white wire from the (s) sensor post of the gauge to the temperature sensor on the hydraulic reservoir tank. (ASM-C-0051)

K < 99 @ K 9 = < H A C I B H B ;

For all tractors using a boom mower, a wheel weight will be required for the rear left side wheel. It will be necessary to mount the weight in the wheel using the long capscrews, lockwashers, flatwashers, spacers (if applicable), and hex nuts per the diagram in the Parts Section.

Installation is most easily done with a fork lift, inserting a fork in the center slot of the wheel weight. The head of the capscrews is to be toward the OUTSIDE of the weight, with flatwashers on both the inside and outside of the assembly.

The left rear tire may also be filled with a mixture of water and calcium chloride at about five pounds per gallon. Tire air pressure should be maintained according to the Maintenance Section. (ASM-C-0055)

G K = J 9 @ 6 F 5 7 ? 9 H A C I B H B ;

Install the boom swivel bracket onto the mainframe with the swivel pin. Secure the pin in place using the capscrews, etc. through the hole in the boss and pin. NOTE: The head of the capscrew must be toward the front of the tractor.

Install all new swivels and fittings on the swing cylinder with swivel openings facing each other. Fittings will vary in type and direction depending on your application; refer to the Parts Section for more details.

Install bearings in the mainframe anchor for the swing cylinder. This may have already been done for you.

Install the swing cylinder between the boom mounting bracket cylinder anchor and the boom swivel with the pins. Insert roll pins through the top and the bottom hole in the pins.

Attach hoses from the control valve to the swing cylinder. (ASM-C-0015)

A 5 - B 6 C C A - B G H 5 @ @ 5 H - C B

Using a hoist, install the boom swivel into the mainframe as shown in the Parts Section. Line up holes in swivel and mainframe for large swivel pin and insert pin. Secure with hardware as shown.

Attach the inner end of the main boom to the swivel bracket with the cylinder anchors positioned upward, and at a right angle to the tractor. Secure it with the horizontal hinge pin. Secure the hinge pin in the boss with capscrews, etc. (see Parts Section).

Attach the butt end of the main boom cylinder to the swivel with the cylinder pin and roll pins shown in the Parts Section.

Install the travel lock on the rod end of the main boom cylinder. This should be facing the butt end of the cylinder after installation.

Install the fittings and hoses to the main boom cylinder per Parts Section.

; F 9 5 G 9 < - B ; 9 D - B N 9 F ? G C B 6 C C A 5 : H 9 F 5 G G 9 A 6 @ M C B 7 9 I B 8 9 F @ C 5 8 K H < 6 C C A 9 @ J 5 H 9 8 Z 5 B 8 5 ; 5 - B 5 H F 9 G H K H < 6 C C A G I D D C F H 9 8 " (ASM-C-0013)



5 GG9 A 6 @M

8 9 7 ? ' 5 H 5 7 < A 9 B H

Attach the head to the secondary boom using the pins and hardware shown in the Parts Section. Install the deck pivot cylinder using the pins and hardware also shown in the Parts Section.

Connect the fittings and hoses from the pivot cylinder to the small hoses or preformed tubes on the boom arm. Connect the fittings and hoses from the motor to the large hoses or preformed tubes on the boom arm. If attaching a rotary mower make sure that the hose with the red stripe sticker is attached to the motor pressure port which is marked with a red dot sticker.

Connect all remaining hoses from the control valve to the cylinders and/or hoses or preformed tubes on the boom arm. (ASM-C-0086)

< C G 9 ' 7 C J 9 F - B ;

Secure hoses together with zip ties wherever loose. Wrap the hoses between the main boom and secondary boom with the hose cover provided. Wrap the hoses between the brake valve and the main boom with the hose cover provided. Wrap the hoses between the deck attachment and the secondary boom with the hose cover provided. Where hoses may contact the frame or other edges, wrap with split hose and secure with hose clamps or zip ties. On non-cab units, the pressure and return hoses from the control valve will also need to be routed inside the protective hose wrap. Cover the valve, valve fittings with the hose cover and secure with black string provided.. (ASM-C-0087)



5 GG9 A 6 @M

CG'5 L @ '6 F579 'ACI BH-B;

The open stow axle braces are to be mounted under the rear axle of the tractor. The other end of the axle brace mounts on the outside of the lower rear corners of the mainframe. After attaching the boomrest, it should fit tightly and level under the tractor. Attach the axle brace(s) to the mainframe with hardware shown in the Parts Section and tighten. Attach the axle braces to the rear axle using the mounting hardware shown in the Parts Section, but DO NOT tighten.

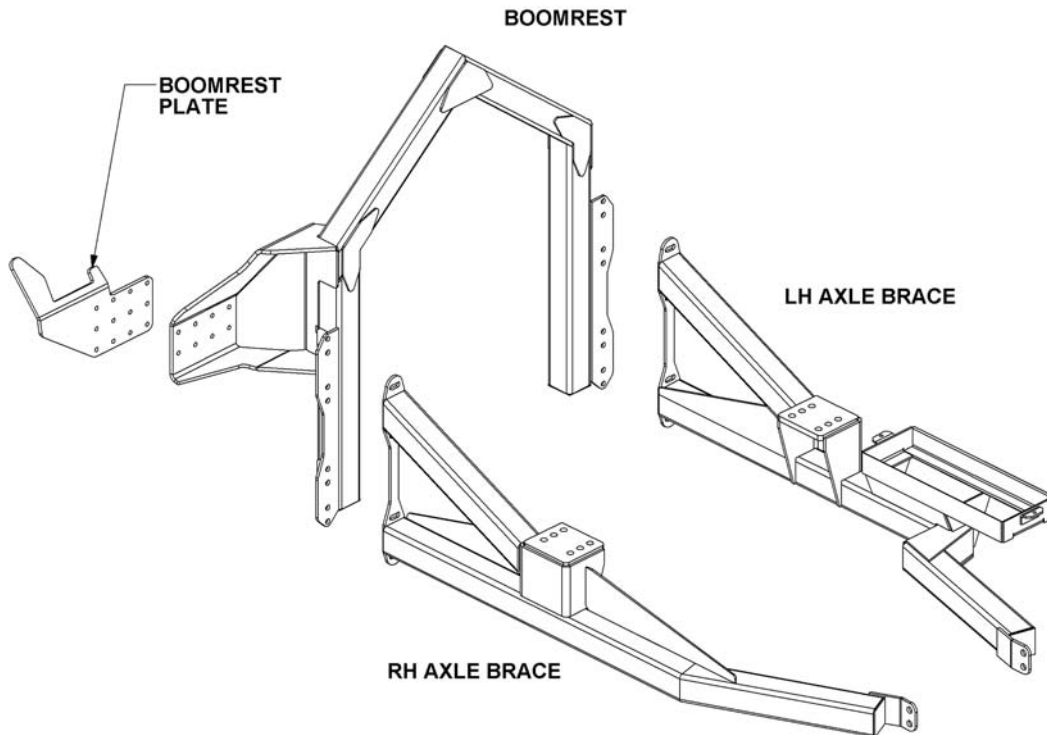

CG'6 CCAF9GH'ACI BH-B;

Carefully raise the open stow boomrest and align the holes with those of the axle brace. Now install all attaching hardware, as shown in the Parts Section, loosely, to allow for the alignment with the left and right axle brace. Tighten / torque all hardware on the brace and the boomrest. Finally, add the boomrest plate to the boomrest as shown in the Parts Section. (ASM-JD-0246)



5 GG9 A 6 @M

K 95H<9F!D57?`#A9HF≠D57?`5 GG9 A 6 @M

These instructions apply to both Weather-Pack and Metri-Pack connectors.

BCH9.1 gYh YgdYWZWtc`zf`h YmdYcZWbbYWcf`nci `UfYUggYa V]b["

(ASM-C-0009)

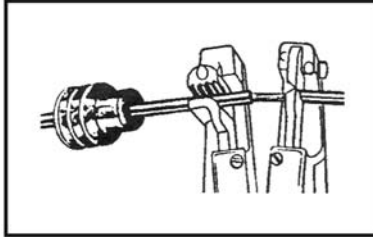

1. Apply seal to cable, before stripping insulation.

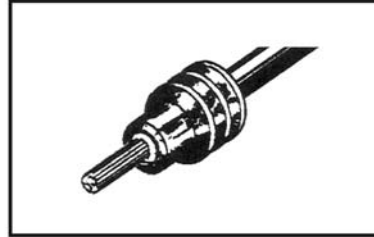

2. Align seal with cable insulation.

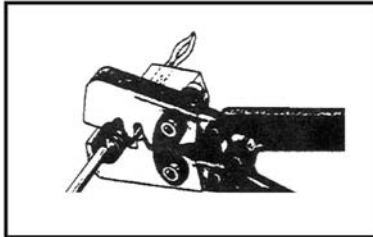

3. Put terminal in crimping tool, then position wire and seal in place.

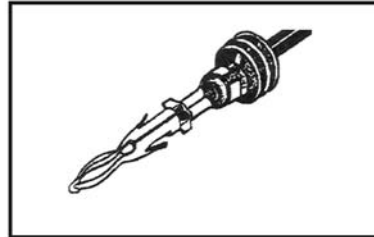

4. Crimp and visually inspect for a good crimp before installing in connector body.



6 CCA >CMGH7 ? '7 CBHF C @7 5 @6 F 5H CB

GI 6!8

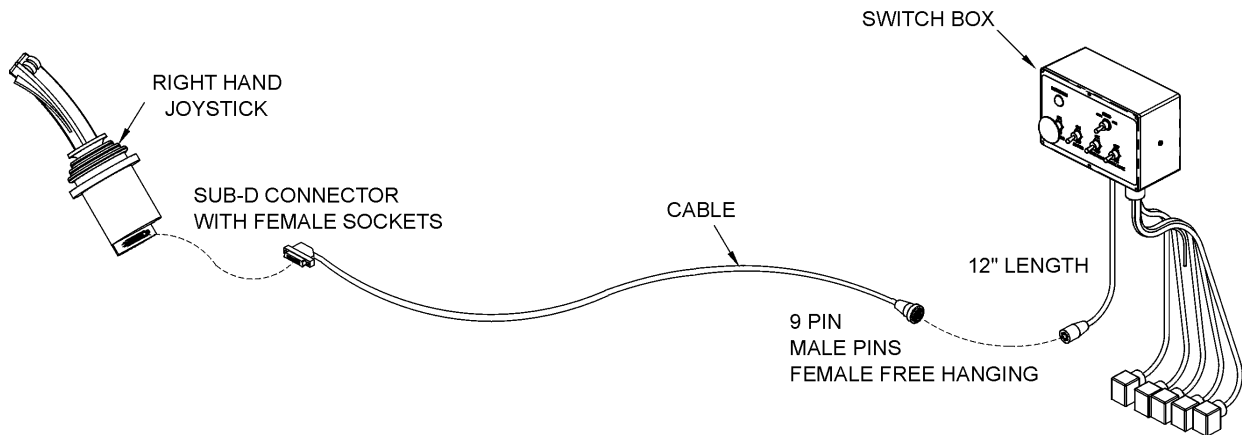

This Electronic control valve is now equipped with higher-resolution actuators on Main Boom, Secondary Boom, Deck Roll, and Swivel functions. These actuators have active fault monitoring. The Deck Shield section does not have active fault monitoring. The joystick is unchanged and provides a ratio-metric voltage signal. The neutral signal voltage is half or 50% of tractor supply voltage. A 25% signal voltage will shift the valve spool to full A-Port, and 75% signal voltage will shift the spool to full B-Port in the Main, Secondary, and Swivel valve sections. On the Deck Roll function a 34% signal voltage will shift the valve spool to full A-Port and a 68% signal voltage will shift the spool to full B-port. If an actuator with active fault monitoring receives a signal from the joystick that is less than 15% or greater than 85% of supply voltage the actuator will “fault out” and shut down. Also, if there is an internal failure in the actuator or if the spool position is greater than that specified by the signal voltage from the joystick, the actuator will “fault out” and shut down. An “active fault” condition causes the actuator to drive the spool to neutral, shut down, and activate a red LED on the top of the actuator. The active fault can be canceled by simply cycling the Master Switch OFF and then ON, which resets the fault monitoring, and causes the LED on top of the actuator to be green again.



The joystick control is equipped with signal adaption potentiometers.

These provide the capability to individually adjust the oil flow to each boom function. It is important that the boom functions do not travel too fast. Excessive boom speed can reduce the stability of the unit and decrease operator control.

Note: Use a Phillips screwdriver and be sure to adjust the screws carefully! DO NOT turn the potentiometers beyond their stopping point, potentiometers are very delicate! Turning the “A” or “B” port potentiometers clockwise increases the oil flow to increase the boom function speed, and turning them counterclockwise decreases the oil flow to decrease the boom function speed. See the graphic on the next few pages for help in adjusting.



5 GG9 A 6 @M

6 CCA >CMGH7 ? 7 CBHFC @75 @6 F5HCB ft CBHBI 98L

Run tractor at normal operating RPM to adjust the settings as follows.

GYHh Y'XYUX'VUbX'Wta dYbgUjcb'dchYbhjca YHf'Zfgh'

Set the dead band compensation potentiometer at 50%, or halfway between full clockwise and full counterclockwise.

GYHjbl 'Gj[bU'5 XUdHUjcb'DchYbhjca YHfg.

Disconnect the Deutsch connectors from the actuators of the valve. Use a Volt/Ohm meter to measure signal voltage and adjust the signal adaptation potentiometers as needed. Pin #4 is tractor supply voltage. Pin #1 is signal voltage from the joystick, and pin #3 is ground. First, measure supply voltage between pins 4 and 3. Then measure signal voltage between pins 1 and 3 while indexing the joystick function fully in both the "A" and "B" port direction. Divide the signal voltage by the supply voltage to get signal voltage as a % of supply voltage. This percentage should not be less than 25% or greater than 75% for the Main Boom, Secondary Boom, or Swivel function. This percentage should not be less than 30% or greater than 62% for the Deck Roll function. Note these initial settings for the Deck Roll function should prevent the spool from shifting into float. *After making this first adjustment to deck roll if the spool still goes into float, adjust the "B" port screw additionally counterclockwise.*

Reconnect Deutsch connectors on control cables to actuators on Electronic valve. Run tractor until hydraulic system is at operating temperature. Now refine the adjustments of the signal adaptation potentiometers for both "A" and "B" ports for all proportional functions to achieve the following function times. Note: turning potentiometer clockwise increases the flow or the function speed, and turning them counterclockwise decreases the flow or the function speed. Note, if during this procedure the trim potentiometer is set to full counterclockwise but the function is still too fast, use the mechanical stops at the manual actuator end of the valve section to further limit flow. Turn limit screw in or clockwise to limit flow. The upper limit screw limits flow to B-port, and the lower limit screw limits flow to A-port. However DO NOT adjust the limit screw on B-port of deck roll function. Limiting B-port will prevent float function.



5 GG9 A 6 @M

6 CCA >CMGH7 ? 7 CBHFC @7 5 @6 F 5 HCB'ft CBHBI 98L

A5-B'6 CCA. "A" Port, Boom Up: 8-10 Seconds
(Note: Extend secondary boom completely; roll deck to be level with ground, and lower main boom until deck is on ground. Now index main boom "up" function and determine the time required for main boom to rise completely.)

"B" Port, Boom Down: 6-8 Seconds
(Note: Extend secondary boom completely, roll deck to be level with ground, and raise the main boom to "full up". Then index the main boom "down" function to determine the amount of time required for the deck to contact the ground. CAUTION: Stop the boom just as the deck contacts the ground.)

G97 CB8 5 FM

6 CCA: "A" Port, Boom Out: 8-10 Seconds
(Position main boom full up, roll deck out until deck cylinder is fully retracted, and bring secondary boom in completely. Then index the secondary boom "out" function and determine the time required for boom to extend out completely.)

"B" Port, Boom In: 8-10 Seconds
(Position the main boom full up, roll deck out until deck cylinder is fully retracted, and extend secondary boom completely. Then index the secondary boom "in" function and determine the time required for boom to come in.)

8 9 7 ? 'FC @@ "A" Port, Deck Out: 7-9 Seconds
(Raise main boom to vertical, extend secondary boom out slightly so that deck can be articulated without contacting the main boom, and roll deck in until deck cylinder is completely extended. Then index the deck roll "out" function and determine the time required for the deck to roll out.)

"B" Port, Deck In: Target 7-9 Seconds (but DO NOT use Limit Screw)
(Raise main boom to vertical, extend secondary boom out slightly so that deck can be articulated without contacting the main boom, and roll deck out until deck cylinder is completely retracted. Then index the deck roll "in" function and determine the time required for the deck to roll in.)

6 CCA

GK →9 @ "A" Port, Boom Aft: 14-16 Seconds for 3PS, 3OS, SS
(Extend booms completely; rotate head to be level with ground, lower main boom until deck is just above ground, and swivel boom full forward. Then index the boom swivel "aft" function and determine the time required for the boom to swivel full aft. Use caution when doing this, stop boom before main boom contacts tire.)

"B" Port, Boom Forward: 14-16 Seconds for 3PS, 3OS, SS
(Extend booms completely, rotate head to be level with ground, lower main boom until deck is just above ground, and swivel boom aft until near tire. Then index the boom swivel "forward" function and determine the time required for the boom to swivel full forward.)
(ASM-C-0082)



ASSEMBLY

BOOM JOYSTICK DIAGRAM (ASM-C-0082A)

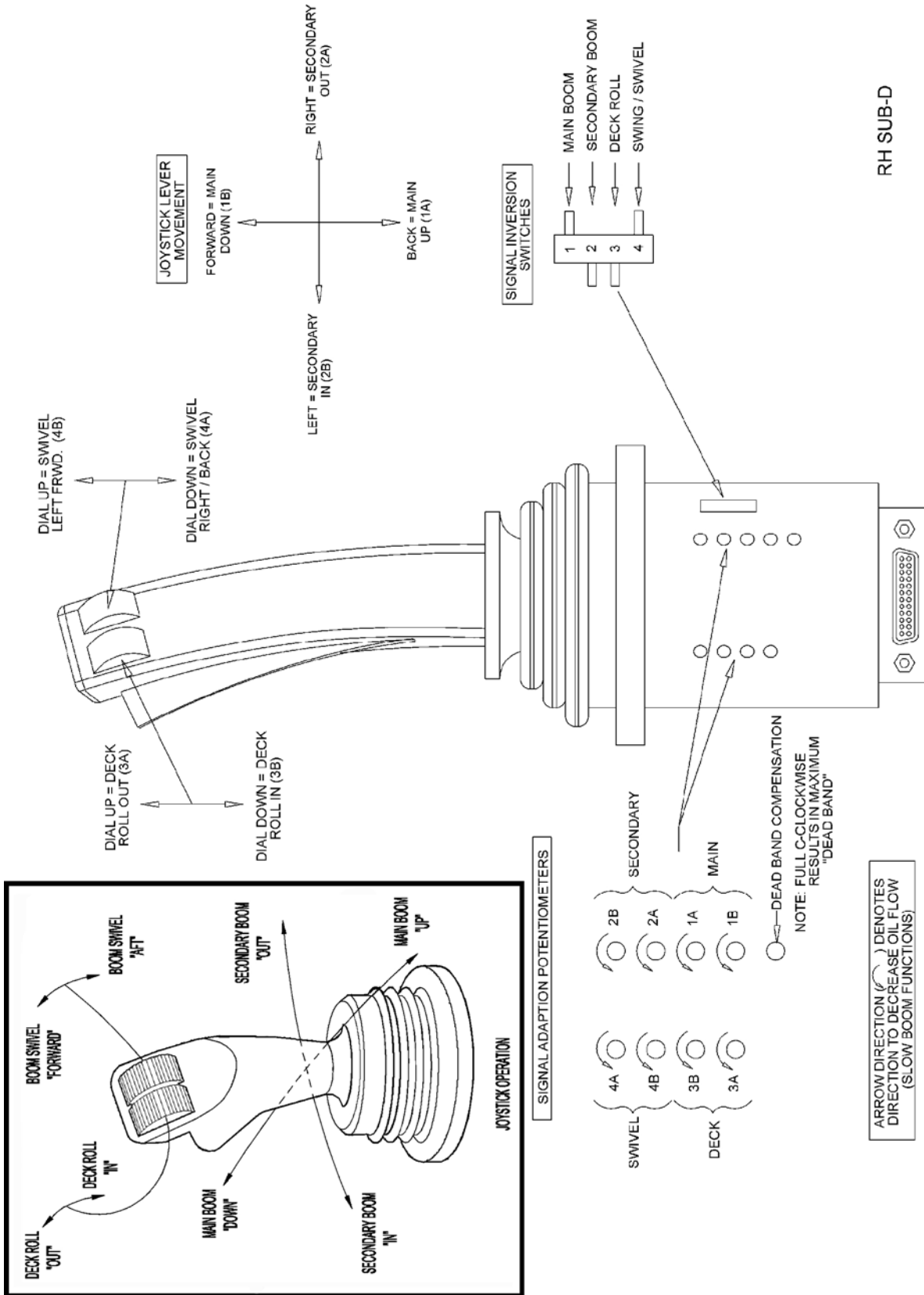

5 GG9 A 6 @M

: B5 @DF9 D5 F 5HCB: CF CD9 F 5HCB

Place operator's safety and operation decals on the steering column and side console where they are clearly visible to the operator. These decals should be understood by each operator of the machine in conjunction with the Safety and Operation Sections of this book. The decals are to be maintained in good condition as a reminder to the operator, and should be replaced if damaged.

All bosses, pins and pivot points will need to be greased as instructed in the Maintenance Section of this manual. The hydraulic reservoir can also be filled with the recommended fluid (see Maintenance Section) and the filter installed in the top of the tank. Double check all fittings and fasteners BEFORE starting tractor. Also secure any loose hoses together with zip ties and wrap with split hoses where friction may occur on the hoses.



BEFORE starting or operating the tractor you must read and understand the Safety and Operation Sections of this manual completely.

69 GI F9 H<9 65 @@J5 @9G5F9 CD9B Start tractor and allow instruments to stabilize. Using a piece of paper or cardboard as noted in the Safety and Maintenance Sections, check all fittings and connections for hydraulic leaks.

If a leak is found, you must shut down the tractor and set the cutter on the ground. Before attempting to fix the leak, you must actuate the lift valve handles several times to relieve any pressure in the lines.

6YZfYcdYfUhb[h Ya ck Yf, the cutter head and boom should be slowly moved throughout the full range of motion. Watch for any condition that would cause pinching or excess stress on the hoses. The steering and front axle travel should also be carefully moved through their full range of motion. If any condition occurs in which the hoses contact the tires, the steering and / or front axle travel may need to be limited as described in the tractor operator's manual. This should also be done if the tires rub, or are extremely close to any other part of the mower, such as the hydraulic tank or draft beam. This may include adding shims or adjusting stop bolts in the tractor front to solve the problem. While checking motion, you should also check that the control circuits are connected according to the operator's decal for the valve handles.

ACK 9F H9GH-B;

Take the tractor to a place free of loose objects on the ground. Operate the cylinders through their full range of motion again, to clear the lines of air. Follow the instructions in the Operation Section to operate the mower. Vibration of the mower should be minimal at all times. After a 5 minute test run, the knife bolts should be retorqued, and retorqued once again after the first few hours of operation.

ZUbridUfhg'cZH Jg'5 ggYa V'miGYWjc bZcf'UbricH Yf'gYWjcb'cZH Jg'a Ubi U'UFY bchWYUf'mi bXYfglccX'nci 'a i ghWcblUWinc i f'XYUYf'cf'h Y'UXXfYgg'cb'h Y'ZcbhcZ h Jg'a Ubi U'Zf'UggJghUbw (ASM-C-0010)



CD9 F5 HCB'G97 HCB

UJ ^!aa } A^&a } A#E

CD9F5HCB

H 9F'6CCA'ACK 9F

CD9F5HB; 'BGHFI 7HCBG

Va^!ÁÓ[[{ •Áe^Á e} ~æc^!^áÁ ã@Á ~æc^Á æ^!æ^Á Á]á^áÁ [[!^•ÉÁV@ÁÓ[[{ ÁÁ ÁÁ•á }^áÁ Áææ&@Á Áe
 dæd^!Áe} áÁ] ^!æ^Áæá ~Á@æá•Á^!Áe} ã^Áæ} *^Á Áç^*^ææ^Á æ} e} æ^Áæ} |ææ} •ÉÁV@Á[[{ Áe} á
 @æá•Áe^Á ~} á] á^áÁ ã@Á æ^c^Á æ} } *Áá&æ ÉÁ [[e&ç^!Áá^!^&ç^!•ÉÁ @|á•Ée} áÁ @|Áæ^c^Áæ^!^Áç
]|çæ^Á] ^!æ^!Áe} áÁæ^!^Áç^!| e&ç^! ÉQ, ^ç^!ÉÁ [Á @|áá *Á ÁÉÉÁ Áæ&^!æ ÉÁÇÉÁæ^c^Á ~} á { ^} e} á
 •æ^c^Á æ} } *Áá&æ Á ~•e^Á æ} æ} á^Á} Á@Á} ãÁ Á[[áÁ] ^!æ} æ} } áá} Áæ^!Á Á•É

QÁ Á@Á] ^!æ^!Áç^!| Á^•} •ææ^Áç^! Á^Á} [[|á^*ææ^!Á Áç^!Á] e} çæ^!] ^!æ} *Áe æá•Áe} áÁ Áæ^Áç^!
 ^æ} } æ^!Á^!^æ ç} Áç^! Á} ~!^Á} ^•^!ÉÁ @|•Ée} á æ^Ée} áÁ] | | ^!c^Áæ^Á] e} b^!áÁ^!Áæ æ^!áÁ^Á@
 à[[{ Á} æ^!æ ç^!Á^!Á@,] Á áb&ç^!Á [e}] ^!æ^Á@Á[[{ Áe} áÁæ&@áÁ@æ^!Á ~} æ^!•ÉÁ æ^!•á^É
] ^ç^!Áç^!^ç^! & Áæ^Á ã@Á ÁÉÉÁ^ç^! Á@Á} æ

V@Á^Á&ç^! Á Á@Á] ^!æ^!Áç^!| Áç^! e} æ^!Á Á•á } ^áÁ Áæ ææá^ÉÁ •ç^! &ç^! áÁá ~ææ^!] ^!æ^! Áç^! Á@Áæ^! á
] | | ^!Á•^Á Á@Á[[{ Áe} áÁæ&@áÁ@æ^!Áç^! ^!Áç^! } æ} á^Á Á@Á^Á&ç^! Áæ^!Áç^! } á^áÁ Á^Á•^Á Áe
 çá ~æ^!Á Áe} á e} Áç^! | æ} } *Á@Á] ^!æ^! Á Áç^![[{ Áe} áÁæ^!Á [e}] ^!æ^! Áç^![[{ ÉÁV[[^Áæ^!Á ç
 •ç^! Á @|á•Á^! { ç^!Á Á} @e} &Áç^! ~æ^!ææ^! ÉÁ ÖXÓUÁ] ^!æ^!Á@Á[[{ Á} ãÁ ã@ ~æ^!Áæ^c^Á ~} á { ^} e} á
] |æ^!Áe} áÁ Á[[áÁ] ^!æ^! } æ^! Á] áá} ÉÁV@Á] ^!æ^! Áç^! ~•e^Áææ^! ã@Á@Á[[{ Á} ãÁ æ} áÁæç^!
] | ^!æ^! } Áe} áÁç^!æ^c^Á Á|æç^!Á^!^!Á^*} } *Á] ^!æ^! ÉÁV[[^!Á] ^!æ^! ÉÁ Á^æ^!áÁ Á@Á e} æ^!Á ç
 @|] Á} ~!^Á^æ^! Áæ^!Áe} áÁææ çç^! Á•^Á Á@Á[[{

F958'5B8'I B89FGH5B8'Hk9'9BHf9'CD9F5HB; 'BGHFI 7HCBG'5B8'G5: 9HMG97HCB'C: 'Hk-G
 A5BI 5 @ 5B8' Hk9' HF57HCF' A5BI 5 @ 69: CF9' 5HH9ADHB; 'HC' I G9' Hk9' HF57HCF' 5B8
 -AD@A9BH' GÁ] ~Á[Á [e}] á^!•æ} áÁe} ^Á Á@Á} •ç^! &ç^! •ÉÁ} æç^! [^!Áæ^•Áe} ç^! |á^!Ááæ^!Áç^! Áe
 ~|Áç^! | æ} æ} ÉÁVæ Áç^! [^!Áæ^!] ç^! Áç^! Áæ^c^Á Áæ} •Áe} áÁæ^c^Á Á••æ^!Áç^! } æ} áÁ Á@Á e} æ^!Á e
 ç^!Áæ ç^!áÁ Á@Á] | { ^} e} áÁæç^! ÉÁ OPS-U-0001)

ÜÖÇÉÁV@ÁÓÜÜVÇÉÖÉÁ áÁÜŠŠUY Á@Áç^! | | , } *Áæ^c^Á Á^••æ^!ÉÁV!á ~•e} b^!Á
 á^æç^! æ^! &ç^! Á] | ••Áæ^!Á Áe} } Áç^! | | , Á@Á æ} } *Áe} áÁe} •ç^! &ç^! } Áæ^!áÁ Á@
 Üæç^! Á^••æ^!ÉÁV, æ^!Á•^Á[[áÁç^! { [] Á^} •^Áç^! Áç^! ãÁe} æá•ÉÁ

SAFETY INSTRUCTIONS



PELIGRO

Uá] Á^!Áç^! | •ÉÁ æææ^! áæææ^! ~} Á^!Áç^! Áç^! ææ^! ^!Áç^! : çææ
 { ^!áææ Á^!Á^*^!æææ ÉÁ

LEA EL INSTRUCTIVO!



Ö[[{ U] ^!æ} } Á^!Áç^! } Áç^!

CD9F5HCB

CD9F5HCB

%CD9F5HCF`F9EI`F9A9BHG

Ùæ^Á] ^íææ } Á -Á@Á } æÁ Á@Á | ^•[]] •æææ Á -Áæ~ ææá áÁ] ^íææ | ÈÁÓÁ~ ææá áÁ] ^íææ | Á@Á ^ææÁæ á
 ~ } á^•ææ á Á@Á Á] | ^ (^) óææ áÁæææ | ÁU] ^íææ | çÁT æ } æ Áææ áÁæ Áæ] | ^æ } & áÁæ Áæ] | ^ (^) óææ áÁæææ |
 [] ^íææ } Áæ áÁæ | Áæ • [&ææ áÁæææ Á] æææ • ÈÁÓÁæááææ } Áç Á@Á æææ Á ^••ææ Áæ] æææ áÁæ Á@Á æ } ææ
 •æææ Á æ } • Áæ Áæææ áÁæ Á@Á Á] | ^ (^) óææ áÁæææ | ÈÁÓÁææ ^ Á æóÁ -Á@Á] ^íææ } Áæ áÁææ Á • ÁÁ -Á@Á
 ^~ æ { ^ } óæ Á] óæ { } | ^æ | Á } á^•ç [áææ] • | óææ Áæ ç [á áÁææææ | Áææ { } | ^æ Áæ] æææ } È

ÇÁ@Á] ^íææ | Áææ } [óÁææÁ@Á æ } æ Á] Á@Á { • | çÁ^ Á] Áæ [Áæ { } | ^æ | Á } á^•ææ áÁ@Á] ^íææ } Á -Á@Á
 ^~ æ { ^ } óæ Á Á@Á Á^•[]] •æææ Á -Áæ~ ^íçæ [| Á Á^ææææ áÁææ] ææ Á@Á æ } æ Èæææ Á] æææ • Èææ á
 [] ^íææ } Áæ • ç & ç } • Á Á@Á] ^íææ | È

Ùæ^Á] ^íææ } Á -Á~ æ { ^ } óÁ~ á^• Á@Á@Á] ^íææ | Á ^æææ } | çÁÁÁ^• [] æÁU | çÁæ Á@Á~ æ { ^ } óÁUÓU
 ç | Á@Á áÁæ] áææ } • Á @ } Áæææææ * È] ^íææ } È | çÁæææ * Èææ áÁ^] æææ * Á@Á~ æ { ^ } óÁUÓU Áæ Áæ • æ } áÁæ
] | çÁæ Á] ^íææ | Á] | çÁæ } Áæ áÁæ & ^ á^• Á@Á Á] | çÁæ * Áæææ Á ^ææ

D9FGCB5 @DFCH97HJ9`9EI`DA9BH`fDD9L

- ~ Çææ Á ^æÁæææ Á@Áæææ
- ~ PæáÁææ
- ~ Ùæ^Á] ^Áæææ Á] [ç Áæ
- ~ Ó | ç^
- ~ P^æææ * ÁU | ç & ç }
- ~ Ó | • Áæææ * Á@Á çææ *
- ~ Ù^•] áææ | Á] Á@Á ç Áæ \ Áæ^ ^ } á^• Á } Á
 [] ^íææ } Áæ } áææ } • È (OPS-U-0002)

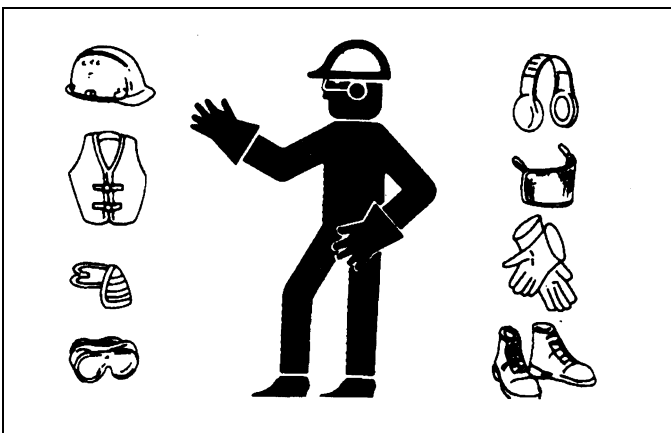

ΠΟΧΟΥΑ^•Áæ~ * Á] Áæææ ç | Áæ { ^ áæææ Áæ ç | ^ Á] Á @Á] ^íææ } Á@Á
 Væææ | Áææ áÁæ] | ^ (^) óÁU~ * Áææ áÁ æææ ç | Á, æ | Áæææ&Áææ Á] ^íææ | ç
 æ^ç Á^• Áææ áÁæ [| áææææ } Áææ áÁ@Á^ ç | ^ Áæææ&Á@Á] ^íææ | ç Áææææ Áæ
 [] ^íææ Á@Á~ æ { ^ } óÁæææ ÈÁU ç | ^ Á] ^íææ } * Á@Áæææ | Á] Á@Á] | ^ (^) óææ
 æ Á] ^íææ | Á } Á] ^• & æ çæ } Á] Á ç | ^ È@Èæ } ç | Á ^ áææææ } Á ~ óææ } • | ç
 ææ ^ áææææ | | Á^• æ } æ Á^• ææææ * Áæ ^ Áæ Áæææ & Á -Á@Á ^ áææææ } Á@Áæ
 , [^ | áÁ@Á áÁÁ@Á æææææ Áæ Á] ^íææ Á@Á~ æ { ^ } óÁæææ ÈÁΠÓΧÓU
 \ } , æ * | Áææ, Áæ ^ [] ^ Áæ Á] ^íææ Á@Á~ æ { ^ } óÁ @ } Á@Áæææ ç Á^• Á]
 & [| áææææ } Áæ Á] ææææ ÁU ^ áæ } Áæ ç | ^ Á] Áææææ Á@Á] ^íææ | Á] Á@Á
 & ^ | áÁ^• | óæ Á@Á] ^íææ | Áæ Á } áÁÁ@Á ç | ^ } & Á Áæ~ * Á] Áæææ ç | Áæ

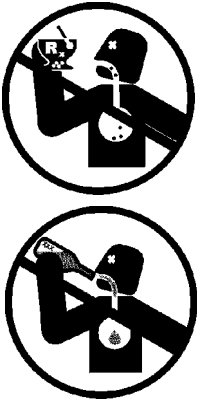

Ó | { U] ^íææ } ÁU & ç } Áæ

CD9F5HCB

CD9F5HCB

⚠ DANGER

P^ç^A[A] ^iæ^A@^A^ædq |Aæj aAT [, ^i^A^M] æj æQ ~ ^æj AUUUUQ] ^iæj |
 Ú: [ç^æ^A^Ud ~ &c | ^D^A | A^OææAç | A: ^ç^ ^ çj b: ^A: [{ A: à^b^æ^A^ç [, } A: [{
 * | [^ } a^A: A: [{ A: ç^ | @ææA: a { a * EAUd] A [, a * A: A [| \ ^ | A: A æ • ^ | a ^
 æ^A æ^ A H E A ^ A ç j O T E D



&" 'HfUWcf' @ [\ Hb ['UbX'GAJ '9a V'Ya

Q@^A:ædq | A: a|A^A^ | ^iæ^ a^A ^æA: | A:æ^ | A^A } Aæ
] ~ à|æA: [ææ, æ^AæA ~ • ç^A^A ~ a] ^a^A æQ: [|] ^i
 , æj a * Aæ @æ * Aæ a^æA^ | , A: [çj a * A^ @æ^A^ QUT XD
 ^ | à | \ { A: @æ^æ^A^æ | A:æ æ | A: A: [{ A: A^æA ~
 @^A } æA^A [• A:ædq | ç^A^æ^Aæ^A^) ç^Aæ * A: |
 [] ^iææ * Aæ a^Açæ •] [| çj * Aæ @æ * EAU^A: A: A^ç
 dædq | A: [] ^iæj | ç^A: çj æ^A: | A: • a * A^ç^Açdq | ç
 | æ @^A , æ&Aæ a^A | ^iææ * A^ç^A: | A: a } æ^A

OPS-B-0017A



Op-86

CD9F5HCB

Ó [{

U] ^iææ } A^æ&ç } A: E

CD9F5HCB

CD9F5HCB

Uphill Operation

When operating the boom on a slope, the operator must be aware of the weight distribution and the stability of the machine. The boom is fully extended, and the counterweight is positioned at the rear of the machine. The ground is level, and the boom is positioned at a height of 2 feet. The weight of the boom is 1500 lbs. The operator should always use proper technique to avoid tipping or instability.

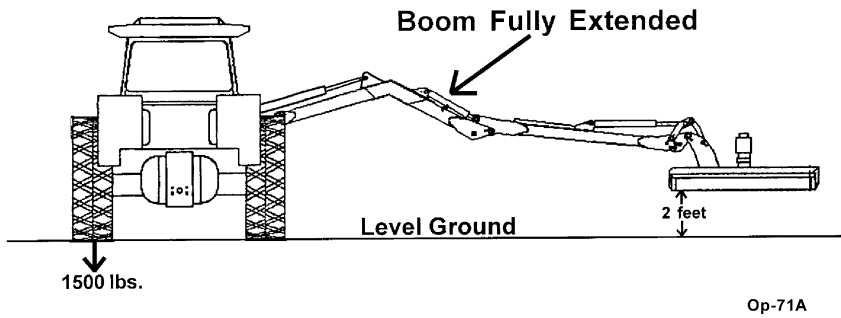

When operating the boom on a slope, the operator must be aware of the weight distribution and the stability of the machine. The boom is fully extended, and the counterweight is positioned at the rear of the machine. The ground is level, and the boom is positioned at a height of 2 feet. The weight of the boom is 1500 lbs. The operator should always use proper technique to avoid tipping or instability.

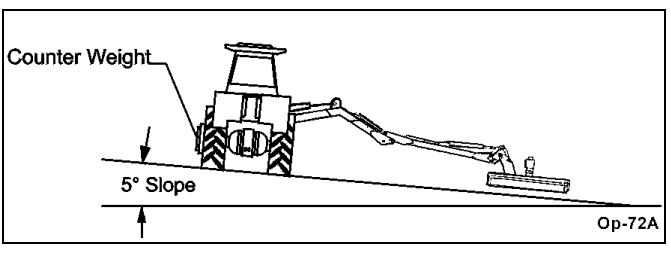

9HCB; CB5B8C: : H<9HF57HCF

When operating the boom on a slope, the operator must be aware of the weight distribution and the stability of the machine. The boom is fully extended, and the counterweight is positioned at the rear of the machine. The ground is level, and the boom is positioned at a height of 2 feet. The weight of the boom is 1500 lbs. The operator should always use proper technique to avoid tipping or instability.

WARNING

When operating the boom on a slope, the operator must be aware of the weight distribution and the stability of the machine. The boom is fully extended, and the counterweight is positioned at the rear of the machine. The ground is level, and the boom is positioned at a height of 2 feet. The weight of the boom is 1500 lbs. The operator should always use proper technique to avoid tipping or instability.



Uphill

Uphill Operation

CD9F5HCB

CD9F5HCB

('GH5 FHCB; 'H<9 'HF57 HCF

V@Á] ^iæ |Á ~ • Á@æ^Áæ [] | ^Á } á^! • æ ää * Á -Á@Á |æ { ^ } &æ } Éæ äÁ] ^iææ } æÁ • ^Á -Áæ | dæd | Áæ | d | • Á^ - | ^Á ææ * Á@Áææ | ÉÁ^ç ä, Á@Áææ | Á] ^iæ | ç Á æ ~ æÁæ äÁæ | • | çæ Áæ ç | ä^á ä^æ | Á | Áææ | Á] ^iææ } / • d ~ &æ } • Á^ ^á^áÉ

Ö • ^ } æÁææ | Á | d | • K

- " S | ææ Á@Áæ } äæ } Á^ É, æ&@
- " S | ææ Á@Áæ } * ä^Á @ ç -Áæ | d |
- " S | ææ Á@Áæ äiææ | æÁæ } d | | Á^ç^! • Á
- " S | ææ Á@Áæ @Áæ } d | | Á^ç^!
- " S | ææ Á@Áæ | æ^Á^áæ çæ äÁæ &@
- " S | ææ Á@Áæ VUÁæ } d | | Á
- " S | ææ Á@Áæ | ä^Á@ææ } d | | Á^ç^!
- " S | ææ Á@Áæ [| Á] ^iææ * Áæ | d | • Á^ • æ Á | Áæç^Áææ | D

Ö - | ^Áææ * Á@Áææ | Á } • | ^Á@Áæ | | , ä * Áæ

- " Ö | } ä ~ &æ | Á | ^É ææ | ^iææ } / • | ^ææ } Áæ äÁ^çæ Áææ | ää * Á Á@Áææ | Á] ^iææ | ç Á æ ~ æÁæ
- " T æ^Á ~ | ^Áæ | Á ~ æä • Éæ ç | ä • Éæ äÁ ç | Á æ^ç Áæ^Á^æ | ^ | / Áæ É
- " V@Áæ ä ä * Áæ^Áæ | É
- " V@Áææ | Áææ { ä • ä } Á^ç^! • Áæ / Áæ | Á^ | Á^ dæÉ
- " V@Áæ [| Á] ^iææ * Áæ | d | • Áæ / Áæ | Á^ dææ äÁ -Á | • äæ } É
- " V@Áæ VUÁæ | d | | Á^ç^! / Áæ^ } * æ^áÉ
- " V@Áæ äiææ | Áæ { | Áææ } d | | Á^ç^! • Áæ / Áæ | Á^ dæÁ | • äæ } É

Ü^ - | Áæ Á@Áææ | Á , } ^ | ç Á æ ~ æÁæ | Áæææ * Á | &^á^! • ÉÁU } | ^Áææ Á@Áææ | Á @Á^Áæ^áæ ä ä | ç^áæ Á@Áææ | Á] ^iææ | ç Áææ Á^ç^! Áæ } æ • Á@Áæ } äæ } Á, æ&@ Á @ | çæ& ææ * Á@Áææ | Á | ^ | [äÉ Öæ | Á@Áææ | Á } * ä^Áæ } } ä * Éææ [äÁæææ^ } æÁæ } ææ, æ@Áææ | Áææ { ä • ä } Áæ | Á^ç^! ç^áæ } æ äÁ } ^ç | ^ç^áææ | Á [ç^ { ^ } É



Á^ç^! Á } Á@Áææ | Á } * ä^Áæ Áææ [• Áæ^ äää * Á | Á æç ~ çææ^ ~ æ^Á^ } çææ } ÉÁV @ Áçæ • Á { ^ • Áææ Á^Áææ æä [~ • Áæ | Á ~ | Á@æç



Üææ Áææ | Á } | Á @ } Á | [| Á^æ^áæ Á@Áææ | Á^æÉÁUææ * Áæ dæd | Áæ Á^æÁææ Á^ • | çæ Áæ | Á | ÁææÉÁU^æÁ@Áææ | Á] ^iææ | { æ ~ æÁæ | Á | [| ^Áæææ * / • d ~ &æ } • É



Ö | { U] ^iææ } Á^ &æ } ÁÉ

CD9F5HCB

CD9F5HCB

WARNING

U^i q a a b e f A a j . ^ & o a e f A [c a * A] a e o A f i A , ^ a e A a a i ^ | a e A , @ } ^ & . . a e A a o a e o | a ^ a A ^ i c a e A a e o E A S [[A f i A [[. ^ A a e o } ^ i . E a [i] [i A a i \ ^ } A] a e o E a j a A ^ a e A f i A [[. ^ A a e a * E A T a e A ^ i ^ A e f A j a A o e A a e a e o * A o a a , a e E A U ^ i q ~ A b i ^ A e a A & & i A f { A [o f a e a e a j * A o e { a e o ^ A a A [[a A [i \ a * A i a ^ i E A U O E F E D

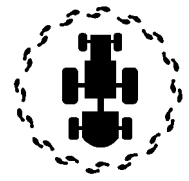

DANGER

O f i U a e c A U @ | a . E O ^ a a . A e a a U a e c A a ^ c a . A a & j a a * A G a ^ o y [c j a a a A f D E a o A O ^ i & d i . E O a e A O ^ a a . E U e ^ i A O ^ a a . E O ^ a a e a [c U @ | a . E U V U A e o i a e A @ | a . E a j a A U ^ c a e a e A O [[i A U @ | a . A @ ~ | a a A ^ . ^ a a e a a A e a e a A a A [[a A [i \ a * A e j } a a e j } E A O f i A e c A a ^ c a . A @ ~ | a A a a j . ^ & o a a e a e ~ | | a e a e o a e a e A f i A a . a * A i A i \ ^ } A e f { [] ^ } o E A T a . a * E a i \ ^ } E [i A a [i] A e { . A ^ . o a e A a } | a e a a e a } & A f A a ^ & A o A j [. . a e a e A a b i ^ A i A e a e o + [{ A o [, } A a b o e E a } a e * i ^ ^ } e A i A i a e a A e j } a e d E A U O T E D

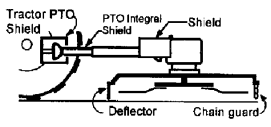

*** % H U W c f ' D f Y ! C d Y f U i c b ' b g d Y W i c b # G Y f j I W**

U ^ i A i A f A o @ A c a e d i A] ^ i a e j i q A e j a e A f A . ~ i ^ A e e f { } | ^ e A i ^ E j ^ i a e a j } A a j . ^ & d j } A e a a A e @ a ^ | a . ^ i c a e A a e A i ^ + [{ a A a e e j i a a * A d A o { a e ~ a e c i ^ i . A i ^ e f { { ^ } a e a e j } . E A V @ A f | | , a * a e A [{ ^ A A o A e { . A o e A ^ ~ a ^ A e a e A i c a e A a e a a j . ^ & d j } K



- " V a ^ A e j } a a e j } E a a j i . ^ . ~ i ^
- " Y @ ^ i A ^ * A i | o A
- " U e ^ i a * A j \ a e ^
- " U V U A @ | a A
- " U T X A a } A e A ^ a e A e a A e a e a i ^
- " V i a e d i q A a @ A e A ^ i e j A e a A ^ } & d j } a e
- " V i a e d i A U a e a e A i o e A A [[a A e j } a a e j } A
- " V i a e d i A U U U U A e A A [[a A e j } a a e j }
- " U U U U A e A A o A a e a a A [. a e j }
- " E [A i a e d i A a j A e a . A
- " U a a e a e j i A ^ A A A e a i a A
- " O) * a ^ A a j A c ^ i A e a A e j } a a e j }
- " O) * a ^ A e j [i e o f c ^ i A e a A e j } a a e j } A
- " U [, ^ i A i a e A f a e A c ^ i A
- " U [, ^ i A e ^ i a * A j a e A c ^ i A
- " O ^ A e j } a a e j } A e a A c ^ i A
- " U ~ a e } o f a i a e a e j } A e a e j A a A [a o
- " O e A a c ^ i A e j } a a e j } A O P S - U - 0 0 3 0

O [{ U] ^ i a e j } A ^ & d j } A e e

CD9F5HCB

WARNING

Ü|aç^A@áiæ|æÁ|!••|^Á|q|Á|Á| q * Áæ ^ Á æ c) æ & Á|Á^ æ Á [\ Á } Á@AQ] \ { ^ } dÉ
 Ú|æ^Á@Á [, ^|Á^æÁ } Á@Á| [~ } áÁ|Á^&^|Á^~] [|cáÁ } Á [& • Á|Áæ á • Éá^) * æ^
 c@ÁUVUÉæ áÁ: } Á -Á@Á } * q ^ ÉÁ ~ • @æ áÁ ~ |Á@Á } d [|Áç^Á • Á|Á^ • æÁ^ç^ÁæÁ^
 ç Á|aç^Á|!••|^Á|q|Á|Á| Áæçá * Áæ ^ Á æ c) æ & Á|Á^ æ Á [\ ÉÁ^UOT È D

WARNING

Þ^ç^ÁÁ^æ^Á@Á [, ^|Á^ } æ^ } á^áÁ @^Á@Á@æÁ^ Á Ác@Áæ^á
 [[• æ] ÉÁ^@Á [, ^|Á^ |áÁæ|Áæ • q * Á^Áq ~ Á b| Á^ Áæ ^ [] Á^ @
 { á @Á æç^Ác) ç^ Á^Á } á^Á@Á [, ^|Á^UOT È D



CD9F5HCB

OUUT ÁEJT ÁEJUOT OSY

- " Q • | ^ & Á } áæ } Á - Áæ @æ { Á & ç } Á | á { ^ } c
- " O) • | ^ Á | Á q • Áæ^ Á | æ^ É
- " O) • | ^ Á | Á [| • É ~ • Áæ áÁ [] | q • Áæ^ Á | [] | Á^ Á q • æ^ áÉ
- " O @ & Á } áæ } Á - Á • @ • Áæ^ [[{ Á q [c] [q • Áæ áÁ@áiæ | Á & | q á^ | Áæ * • É
- " O) • | ^ Á æ @ @ áíæ | Á & | q á^ | Áæ q • æ^ áÁæ áÁ | ^ æ^ áÁ | | ^ & ç ÉÁ^) • | ^ Á @ Á | [] | Á^ á^ Á q • Á æ^ Á • áÁ | Á æ^ Á @ & | q á^ | Áæ | q á^ Áæ áÁæ^ Á & | ^ áÁ | [] | Á^ ÉÁ^OPS-B- 0022_D



WARNING

Þ^ç^ÁÁæ^ { } c^ Á | ^ áíæ | Áæ^ Éá b • É | Á^ [ç^ Á | æ^ | Áæ^ [{ Ác@AQ] \ { ^ } c } @^ Áæ^ Á { [ç] Á | Á @^ Áæ ç | Á } * q ^ Á^ Á } } q * ÉÁ^UOT È D

PYOUÇVSOASÇ OAD UJOOVQJP

- " O @ & Á | Á @ áíæ | Áæ^ áÁ } * Áq • Á • É & | q á^ | Áæ áÁæ * • É - A D C F H B H Á Ç Ö U V Á ~ • Á [~ | Áæ á • Áæ & Á | Á q^ á • É Á^ Á Á] æ & Á - Á @ æ^ Á q | Á | Áæ áá | æ áÁæ & Á | Á @ áíæ | Áæ q^ á • É
- " Q • | ^ & Á @ Á } áæ } Á - Á @ Á ç^ Á [] ç * É
- " O) • | ^ Áæ * • Áæ^ Á | [] | Á^ Á } } ^ & ç áÉ OPS-B- 0023_D

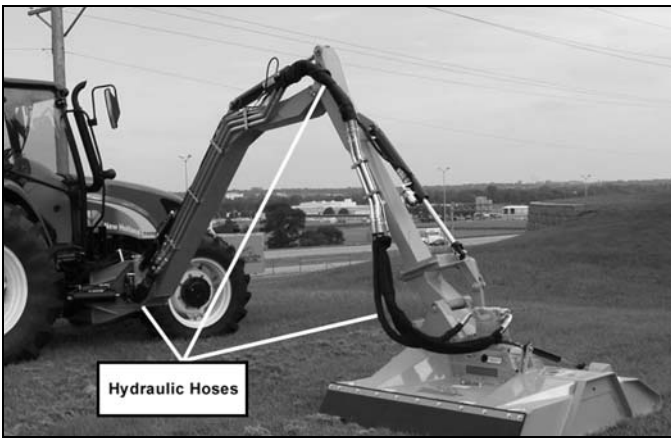

Ó [{ U | ^ æ } Á ^ & ç } Á É G

CD9F5HCB

CD9F5HCB

ÜUVÖÛÿ Á Þ Ò Ó Ô Ù Ú Ó Ö Õ Ò Þ

- " Q.] ^ & ß | æ ¸ • Æ ¸ ð Æ | æ ¸ Æ | [ò Á | Á [• ^] • • Á æ ð á Á ç & • • Æ ¸ Á ^ æ Æ Ú [æ ¸ Á Á € ¸ Á Á æ ¸ Á ð | Æ @ & ð * Á æ ð Æ Ú ^ | æ ¸ Æ æ æ ¸ ^ á Æ [] Æ æ ð á Á ð • ð * Æ | æ ¸ • Æ Æ [{] | ç Á ¸ Á Á { æ æ Á | æ ¸ Æ æ æ & É
- " Ò) • ~ | Á [ð | Æ | [ò Á æ á Á ~ ò Æ ¸ Á æ @] ^ á Á Á @ Æ] | [] | æ ¸ Á | ~ ^ É
- " Ò) • ~ | Á ^ á à Æ ¸ Á ~ ð & ð | • Æ ¸ Á Á [• æ] Á æ á Á } [ò Æ æ æ ¸ á Æ Ú ^ | æ ¸ Á [] Æ [\ ^ } Æ á Á { ð • ð * Á ^ & ç } • Æ { ^ á æ | É
- " Ò) • ~ | Á @ á æ | æ ¸ Á • Æ ¸ Á | [] ^ | Æ] } ^ & ç á Á ð Á @ Á @ á æ | æ [ð | Æ @ & Á | Á @ á æ | æ | æ • Æ] * Á @ • • Æ á Á æ * • Æ Ú Á UV Á • Á ^ [| Á @ á • Á Æ @ & Á | Á á Á æ • Æ ^ Á æ á & Á [Á @ æ ^ Á æ ^ Á | Æ æ á à | æ á Á Æ @ & Á | Á @ á æ | æ á Á æ • É
- " Q.] ^ & ß @ Á [] á æ } Á Á & Á | æ Á @ Á • Æ á Á @ æ , æ ^ Æ OPS-B-0025



Ò | Á [ò] ~ ò @ á á • Á | Á ^ ç } á | Á [, ^ | Á & • Æ @ | æ ¸ Á @ [] æ & ç Á ^ ~ | ç á Á | á ~ • Æ ð | ^ Á | Á ç ^ Á æ æ Æ Ú æ Á æ æ Á } ç Á | Á [ç] Á @ Á ç [] ^ á æ ð á Á @ Æ @ & • Æ ^ Á ^ & ^ | Æ [& ^ á Á] Æ



Ç Á Ú æ ¸ ç Á Ú @ | á • Æ Ó ~ æ á • Á æ á Á [@ | Á • æ ¸ ç Á á ç æ • Æ & ð á æ * Á ç ~ ó) [ó] á æ á Á ç Æ É Ò ^ ~ ð & ð | • Æ Ú ç ^ Á Ó ~ æ á • Á æ á Á Ó ~ æ á | ç Á Ú @ | á • Á ~ • ó á ^ Á • ^ á Á æ á Á æ æ æ ^ á Á ç Á [á , [\ á * Á] á æ } Æ Ç Á æ ¸ Æ ^ ç æ • Á @ ~ | á Æ Á •] ^ & ç á á æ ~ | | Á ç á æ ò Æ æ Á | Á ð • ð * [| Æ | \ ^ } Æ { [] ^ } ò Æ ð ð • ð * Æ [\ ^ } Æ | Á [] Æ { • Á ~ ò Æ Á ^ | æ ¸ á Á ç } & Á Á Á á ~ & @ Á [• • æ ç Á Á Æ ð | ^ Á | Á æ æ [{ Á @ [, } Á á ð & ò Æ] ç * | ^ ^ } ç | Á | æ ¸ Á [] æ & ç

Ó [{

U] ^ æ } Á ^ & ç } Á È |

CD9F5HCB

CD9F5HCB

OPERATION

- The operator must wear seat belt and use proper tie-down technique when operating the machine.
- The operator must wear proper PPE (hard hat, safety glasses, earplugs, ear muffs, work clothes, steel toe shoes, and gloves).
- The operator must not drink alcohol or use drugs before operating the machine.
- The operator must not operate the machine if they are tired or impaired.
- The operator must not operate the machine if they are under the influence of alcohol or drugs.
- The operator must not operate the machine if they are wearing headphones.
- The operator must not operate the machine if they are wearing a cell phone while driving.
- The operator must not operate the machine if they are wearing a watch or jewelry.
- The operator must not operate the machine if they are wearing loose clothing.
- The operator must not operate the machine if they are wearing sandals or flip-flops.
- The operator must not operate the machine if they are wearing high heels.
- The operator must not operate the machine if they are wearing shorts or skirts.
- The operator must not operate the machine if they are wearing a hat that is not secured.
- The operator must not operate the machine if they are wearing a hat that is not properly secured.
- The operator must not operate the machine if they are wearing a hat that is not properly secured.
- The operator must not operate the machine if they are wearing a hat that is not properly secured.



WARNING: Do not operate the machine if you are under the influence of alcohol or drugs, or if you are wearing headphones or a cell phone while driving. Do not operate the machine if you are wearing a watch or jewelry, loose clothing, sandals or flip-flops, high heels, shorts or skirts, or a hat that is not properly secured.



WARNING: Do not operate the machine if you are under the influence of alcohol or drugs, or if you are wearing headphones or a cell phone while driving. Do not operate the machine if you are wearing a watch or jewelry, loose clothing, sandals or flip-flops, high heels, shorts or skirts, or a hat that is not properly secured. Do not operate the machine if you are wearing a hat that is not properly secured.

UJ

UJ

CD9F5HCB

CD9F5HCB

CD9F5HCB

OPS-U-0031

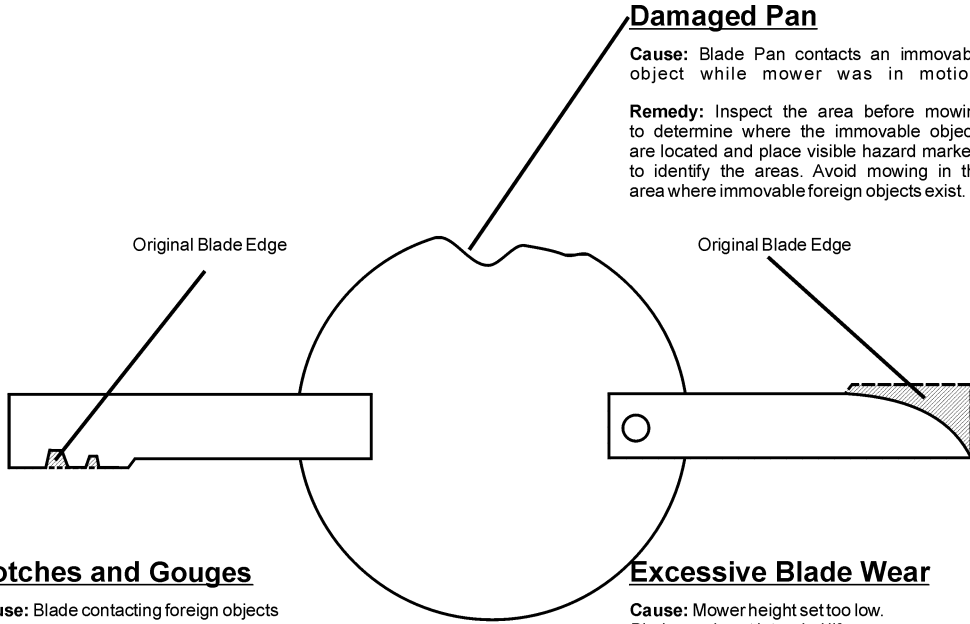

Damaged Pan

Cause: Blade Pan contacts an immovable object while mower was in motion.

Remedy: Inspect the area before mowing to determine where the immovable objects are located and place visible hazard markers to identify the areas. Avoid mowing in the area where immovable foreign objects exist.

Notches and Gouges

Cause: Blade contacting foreign objects

Remedy: Inspect the area to be mowed and remove foreign objects that could cause damage to the blades

Excessive Blade Wear

Cause: Mower height set too low. Blade used past intended life.

Remedy: Replace blades more often. Adjust mower height for mowing conditions to eliminate blade-to-ground contact

Op-22



CD9F5HCB

- " CD9F5HCB
- " CD9F5HCB
- " CD9F5HCB
- " CD9F5HCB
- " CD9F5HCB

CD9F5HCB

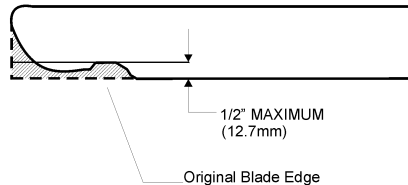

NOTE: Replace Blades in pairs after no more than 1/2" (12.7mm) wear
Op-23

CD9F5HCB

CD9F5HCB

CD9F5HCB

Tractor PRE-OPERATION Inspection



Mower ID# _____ Make _____

Date: _____ Shift _____



WARNING Read the operator's manual before operating the tractor. The tractor is designed to be used only for the purposes intended by the manufacturer. Do not modify the tractor in any way. Do not use the tractor for any purpose other than that intended by the manufacturer. Do not use the tractor on any surface that is not designed to be used by the tractor. Do not use the tractor in any way that is not intended by the manufacturer. Do not use the tractor in any way that is dangerous to yourself or others. Do not use the tractor in any way that is illegal. Do not use the tractor in any way that is prohibited by law. Do not use the tractor in any way that is prohibited by local, state, or federal regulations. Do not use the tractor in any way that is prohibited by any other applicable laws or regulations. Do not use the tractor in any way that is prohibited by any other applicable laws or regulations.

CD9F5HCB

Item	Condition at Start of Shift	Specific Comments if not O.K.
The flashing lights function properly		
The SMV Sign is clean and visible		
The tires are in good condition with proper pressure		
The wheel lug bolts are tight		
The tractor brakes are in good condition		
The steering linkage is in good condition		
There are no visible oil leaks		
The hydraulic controls function properly		
The ROPS or ROBS Cab is in good condition		
The seatbelt is in place and in good condition		
The 3-point hitch is in good condition		
The drawbar pins are securely in place		
The PTO master shield is in place		
The engine oil level is full		
The brake fluid level is full		
The power steering fluid level is full		
The fuel level is adequate		
The engine coolant fluid level is full		
The radiator is free of debris		
The air filter is in good condition		

Operator's Signature: _____

DO NOT OPERATE an UNSAFE TRACTOR or MOWER

Read the operator's manual before operating the tractor.

© 2013 Alamo Group Inc.

CD9F5HCB

Boom PRE-OPERATION Inspection



Mower ID# _____ Make _____

Date: _____ Shift _____



WARNING 6 YZ:fY'W:bXi W]b['h Y']bgdYW]cbžā U_Y gi fY'h Y'fUW'cf 'Yb[]bY']g'cZZU''fcHU]cb'\ Ug
 glcddYX' UbX' h Y' fUW'cf']g']b' dUf_' k]h ' h Y' dUf_']b[' VfU_Y Yb[U] YX'' AU_Y gi fY' h Y'
 a ck Yf']g'fYg]b['cb'h Y[fci bX'cf'gYW fY'miV'cW_YX'i d'UbX'U''\ mXfU']WdfYggi fY'\ Ug
 VYYb'fY]Yj YX''

Table 1:

Item	Condition at Start of Shift	Specific Comments if not O.K.
The Operator's Manual is in the tractor		
All safety decals are in place and legible		
The mounting frame bolts are in place and tight		
The boom connection bolts & pins are tight		
There are no cracks in boom		
The hydraulic cylinders pins are tight		
The hydraulic pump hose connections are tight		
The hydraulic valve controls function properly		
There are no leaking or damaged hoses		
The hydraulic oil level is full		
There is no evidence of hydraulic leaks		
The blades are not chipped, cracked or bent		
The blade bolts are tight		
The deflectors are in place and in good condition		
The boom shields are in place and in good condition		
The skid shoes are in good condition and tight		
There are no cracks or holes in boom deck		
The hydraulic motor mounting bolts are tight		
The boom head spindle housing is tight and lubricated		

Operator's Signature: _____

DO NOT OPERATE an UNSAFE TRACTOR or MOWER

Ó [{

U] ^ ! a a } Á ^ & c a } Á E Ì

CD9F5HCB

Cable Controlled Mowers

© 2013 Alamo Group Inc. All rights reserved. This document is the property of Alamo Group Inc. and is to be used only for the purpose specified. No part of this document may be reproduced without the prior written permission of Alamo Group Inc.

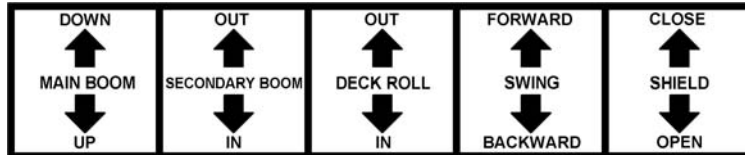
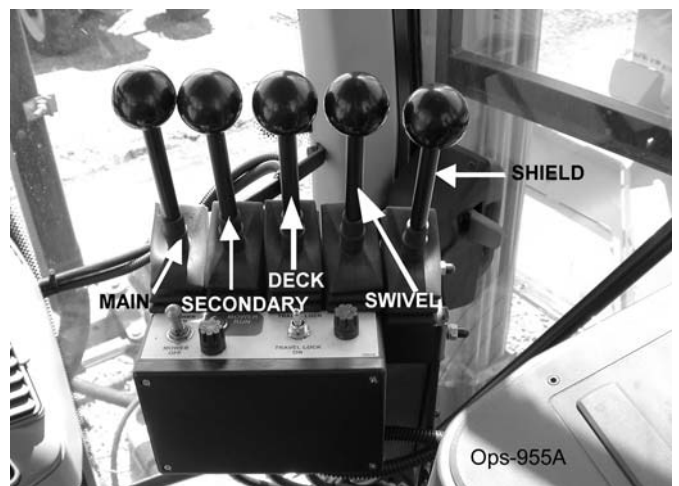
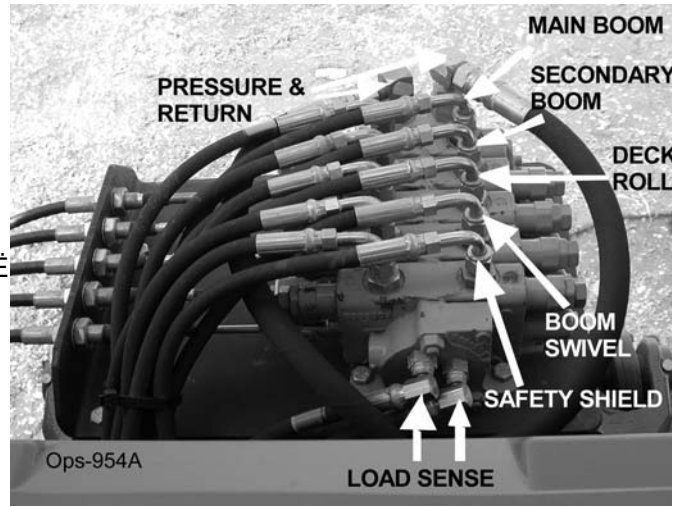

Diagram illustrating the control functions for the cable-controlled mower components. The controls are arranged in a row of five boxes, each with two arrows indicating the direction of movement or action. The labels are: MAIN BOOM (DOWN/UP), SECONDARY BOOM (OUT/IN), DECK ROLL (OUT/IN), SWING (FORWARD/BACKWARD), and SHIELD (CLOSE/OPEN).



CD9F5HCB

CD9F5HCB

CD9F5HCB

* 'Y 'Gk JHW Vcl

V@ÁÚæc ÁÚ@|áÁç^iÁ] ^} • Áæ áÁ&| [• ^ • Á@Á @|á
 || &æ áÁ } Á@Á [] çÁ Á@Á& ç^iÁ@æÉY @) Á [çá *
 æÁ iÁ ^æÁ@Á i [~ } áÉæ, æ • Á@ç^Á@Á @|áÁÁ Á@
 &| • ^áÁ [• áá } ÉY @) Á [, á * Áá Á@Á! ~ • @| iÁá
 ç^Á ç^Á i [~ } áÁç^iÁ@Á @|áÁ æ Á^Á] ^} ^á
 † iÁæ áÁ& çá * ÉÚ^æáÁá áÁ || , Á@Á æ } á * Á }
 ç^Á^ &ç^ Á @ , } Á^ || , ÉÚ [Á [ç^ } Á@Á& ç^iÁ@æ
 á ç Á æ i ááá * ^ i Á@á Á ^ááæ ^ ç i É

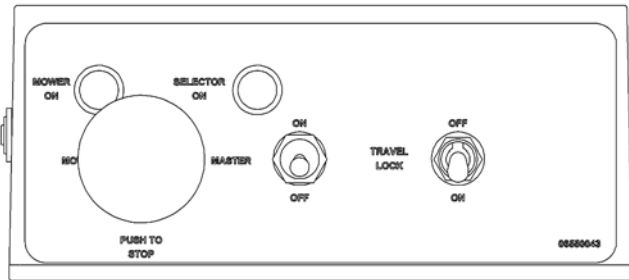

DANGER

SAFETY SHIELD & DEFLECTOR OPERATION

<p style="text-align: center; font-weight: bold;">SAFETY SHIELD</p> <p style="text-align: center; font-weight: bold;">DEFLECTOR</p>	<ul style="list-style-type: none"> • Failure to close Safety Shield and Deflector may allow objects to be thrown outward with great force which can cause property damage, bodily injury, or death. <ol style="list-style-type: none"> 1. Keep Safety Shield and Deflector fully closed when cutting grass and weeds to reduce possibility of objects being thrown outward by the Blades if persons are in the area. 2. Before Cutting brush, trimming limbs, or other such operations, raise the Deflector and Safety Shield fully to allow the blades to contact the material if area is clear of passerby. Operator must stop cutting and close shield if passerby enters the thrown objects area or blade contact area. 3. Repair or replace Safety Shield and Deflectors as needed. 4. Always transport with Safety Shield and Deflector closed.
---	--

02967867

© 2013 Alamo Group Inc.

CD9F5HCB

CD9F5HCB

ŠÒXÒÜÄÄFÄT ÖÄÄÓUUT

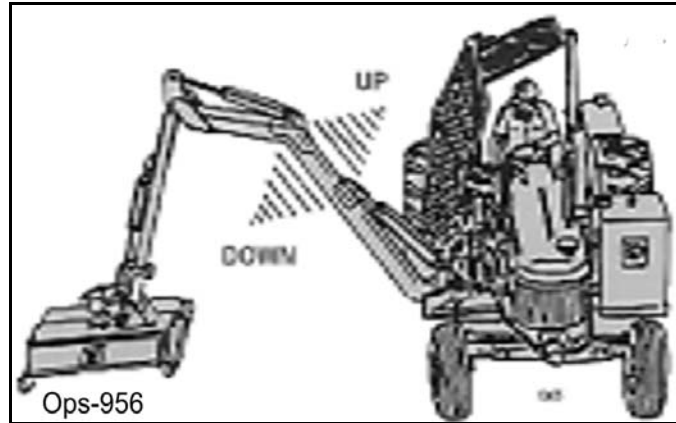

ŠÒXÒÜÄÄGÄÜÒÖUÄÖÄÜÄÓUUT

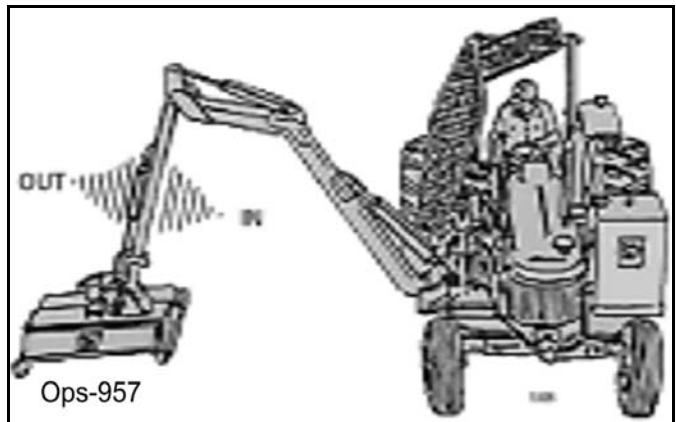

ŠÒXÒÜÄÄHÖÖÖSÄÜUŠŠ

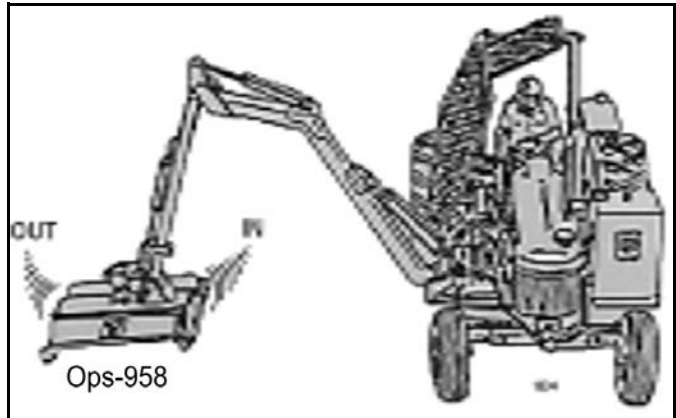

Ó[[{

U] ^! aä } Ä^ & ä } ÄÄÄ

CD9F5 HCB

CD9F5 HCB

ΣΧΟΔΙΑΙ ΑΟΥΤ ΑΥ ΑΟΣ

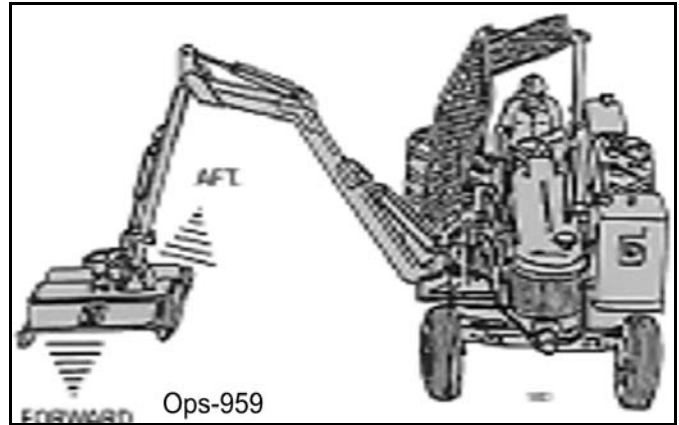

ΣΧΟΔΙΑΙ ΑΟΥΤ ΑΥ ΠΟΣ

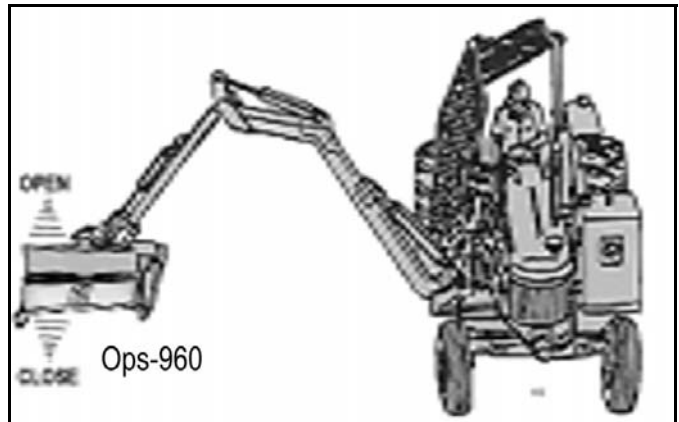

Ó[{

U] ^! aã } Á^ & ç } Á Ë G

CD9F5HCB

CD9F5HCB

WARNING

WARNING

CAUTION: Do not touch the boom or secondary boom while the machine is in operation. The boom and secondary boom can move unexpectedly and cause injury or death.

Always use proper lifting techniques. Do not lift or move loads that are too heavy or unbalanced. Always use the correct tie-down technique to secure loads. Always use proper tie-down technique to secure loads. Always use proper tie-down technique to secure loads.

CAUTION

CAUTION: Do not touch the boom or secondary boom while the machine is in operation. The boom and secondary boom can move unexpectedly and cause injury or death.

CAUTION

CAUTION: Do not touch the boom or secondary boom while the machine is in operation. The boom and secondary boom can move unexpectedly and cause injury or death.

Always use proper lifting techniques. Do not lift or move loads that are too heavy or unbalanced. Always use the correct tie-down technique to secure loads. Always use proper tie-down technique to secure loads. Always use proper tie-down technique to secure loads.

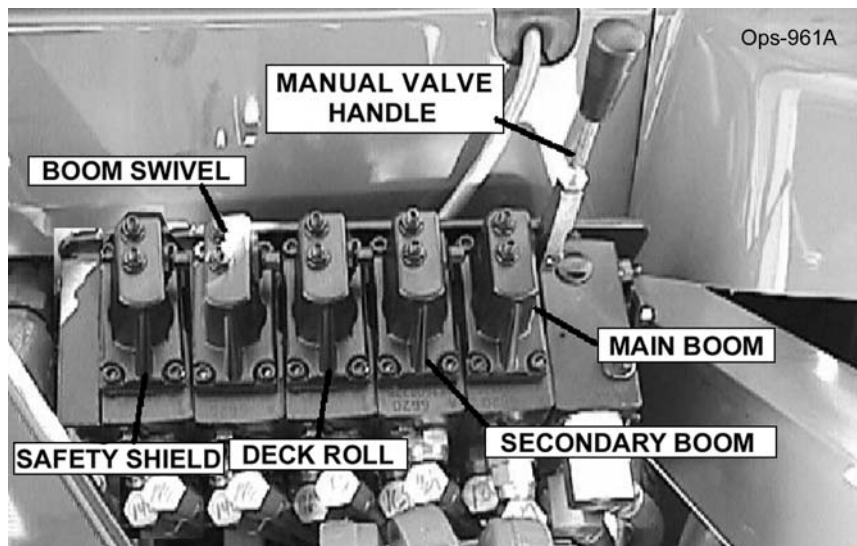

©

U

CD9F5HCB

CD9F5HCB

Control Panel

Refer to the operator's manual for detailed instructions on the control panel. The control panel includes a Mower Run Indicator Light, Mower Control Switch, Joystick Master Switch, Safety Shield Switch, Travel Lock Switch, and Deck Float Switch.

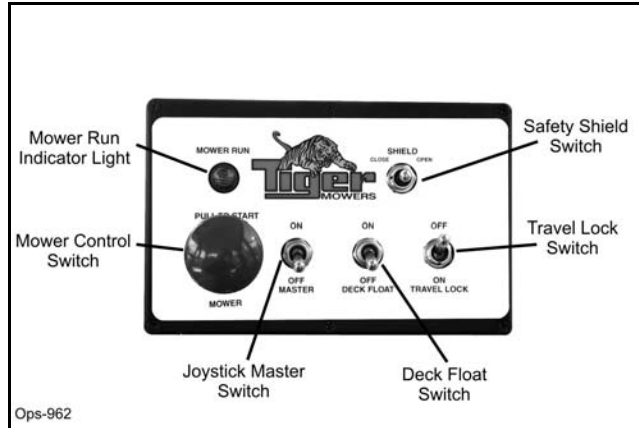

The control panel is located on the left side of the operator's seat. It includes a Mower Run Indicator Light, a Mower Control Switch, a Joystick Master Switch, a Safety Shield Switch, a Travel Lock Switch, and a Deck Float Switch. The Joystick Master Switch is used to control the mower's movement. The Safety Shield Switch is used to engage the safety shield. The Travel Lock Switch is used to lock the travel controls. The Deck Float Switch is used to control the deck height.

! **DANGER**

SAFETY SHIELD OPERATION

- Failure to close Safety Shield may allow objects to be thrown outward with great force which can cause property damage, bodily injury, or death.

1. Keep Safety Shield fully closed when cutting grass and weeds to reduce possibility of objects being thrown outward by the Blades and to prevent contact with the Blades if persons are in the area.
2. Before cutting brush, trimming limbs, or other such operations, raise Safety Shield fully to allow the blades to contact the material if area is clear of passersby. Operator must stop cutting and close shield if passerby enters the thrown objects area or blade contact area.
3. Repair or replace Safety Shield as needed.
4. Always transport with Safety Shield closed. Ops-963

1

2

CD9F5HCB

CD9F5HCB

>cmghW`7cbf c`

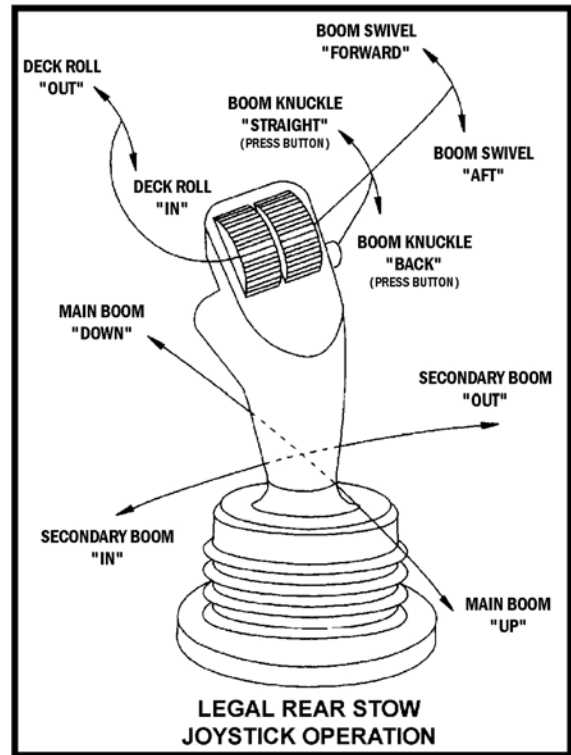
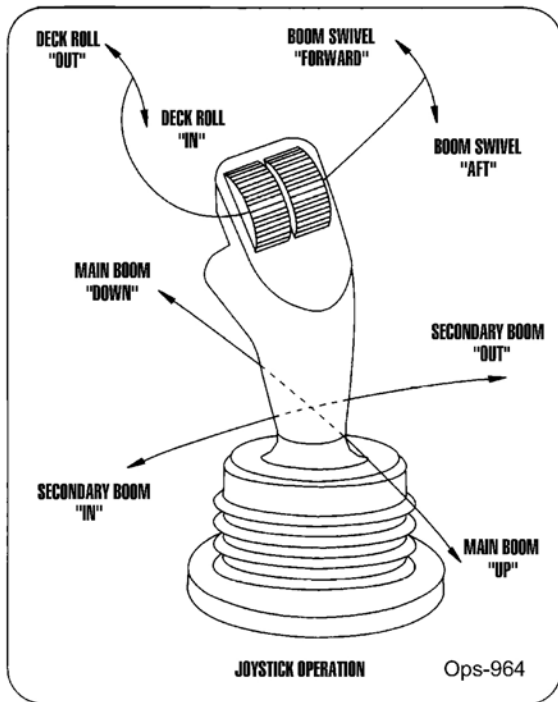

RUÿÙVÔSÁY ÖÖCÔSÁ UXÒÙÁ CD ÁÓUT

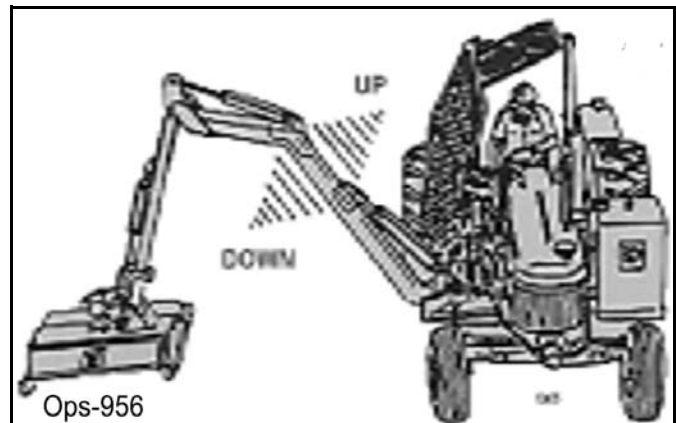

Ó[[{

U] ^! aã } Á ^ & ç } Á Ë Ì

CD9F5HCB

RU'YUVWXSASZVWXPVAT UXOU'AU'OU'OP'OEY' OOUT

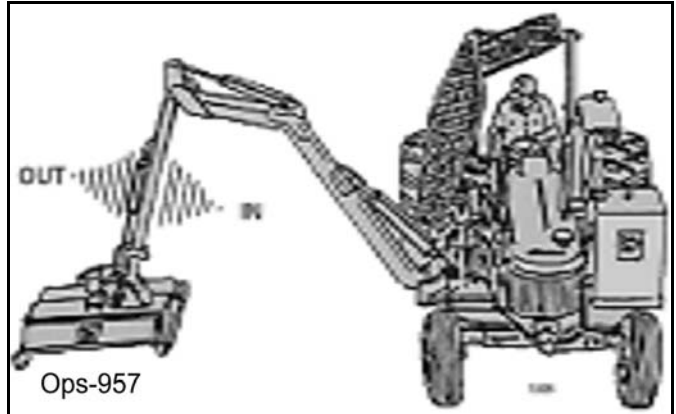

SZV'RU'YUVWXS'AU'SS'OU'AT UXOU'AU'OU'OS'AU'SS'

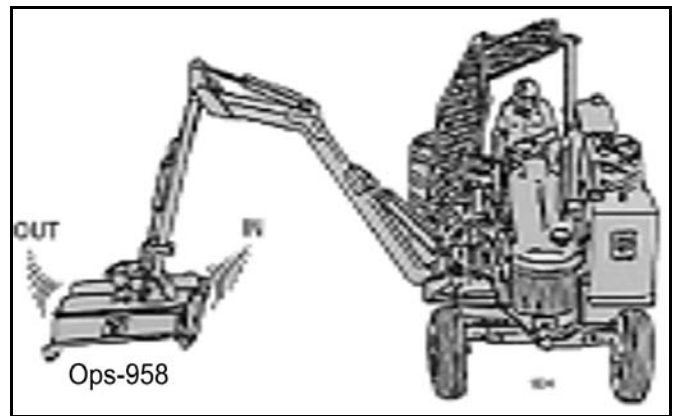

U'OPVA'RU'YUVWXS'AU'SS'OU'AT UXOU' AU' OOUT UY' QOS'

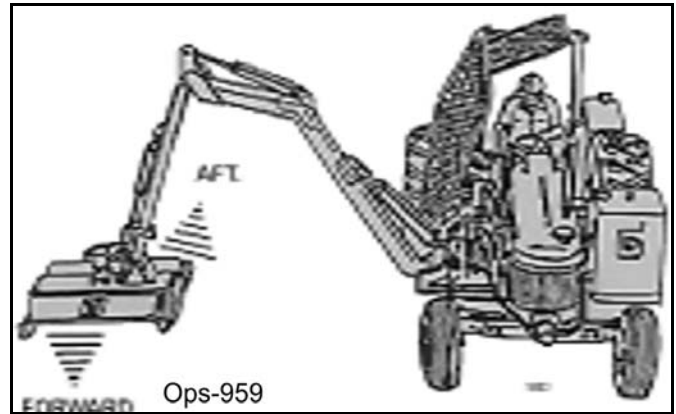

CD9F5HCB

CD9F5HCB

ÜÖPVARJYÜVÖSÄÜSŠÖ ÜÁY PÖÖÁÜÖ ÜÜÖÖ
 ÓVVUÞÁ UXÖÜÁÖUT ÁÞWÖSÖÁÞÞÖSÖÖÖ
 ÜÖÖÁVUY ÁÖUT

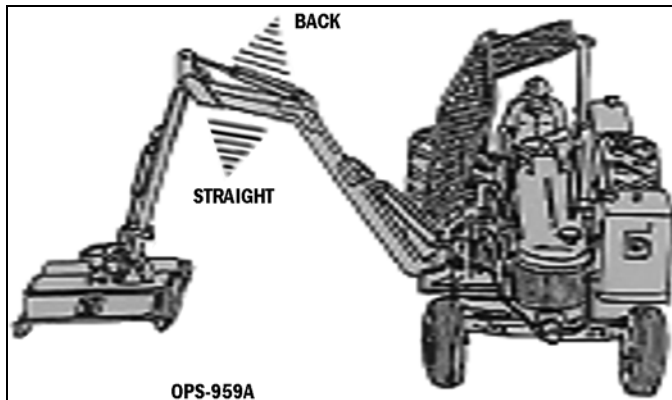

ÜPÖSÖÁ ÜY ÖÖPÖ} Á•, ÖÖÁ à[ÖÁ UÜÖÖÖÜ
 ÜÖÖVYÁPÖSÖ

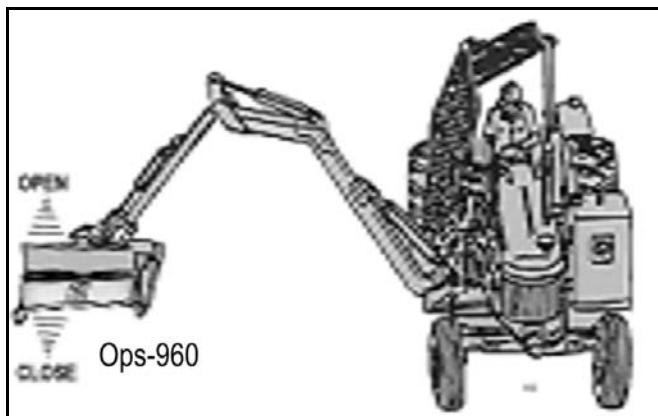

'8F=B; 'H<9 'HF57HCF'5B8'AD@A9BH

ÜæÁÁæd |Áæ•] |!Á^~ ¢•Á@Á]!æ |Á Á [••••ÁÁ@ |! ~ * @Á] [|ã*^Á -Á@Á [ã^Áã * Á]!æ ¢ã
 æ áÁ ^æ ç } •Á Áæ ^Á @^Áã * Á @æ Áææ@áÁ] |{ ^ } ÖÖ) • ^Á@Áæd |Á@ Á@Áææ ææ Á
 @æ á^Á@Á ^æ @Á -Á@Á [[{ Áæ ¢Á@Áæd |Á]!æ * Á } d | • Áæ^Á^Á |Áæ Áæ •] |ÖÁ Á } ^Áæ¢
 , @^Áã * Á@Áæd |Á @æ [[{ Éã, Á@Á ||, ¢ * É

ÜææÁæÁæ¢ Á •d &ç } •ÖÖ&ç Á } Á@Á [{ Á æ } Á [^ Á ææ |ææ áÁ ~ |ç |Áææá • ÖÜ [{ ^Áæ&ç
 æ^Áææ@áÁ & | ^Á Á æÁ -Á@ ÁÖ [{ Á @ ^Á@ ^Áæ Á [•æ |ÁæææáÁææ Áæ áÁ æ ^Á ^Á [~
 ~ } á! • çæ á@Áæ¢ Á (^•æ ^Áæ | ^Á [^ Á]!æ Á@Á] |{ ^ } ÖÖ^Á^Á Áæ |Áæ&ç Á^æ Áæ áÁæææ |É
 Ü] |æ^Á • ç | Áææ æ ^Áæ&ç ÉÁ ^Á Áæ¢ Á &ç } Á [| ^ Á [| æ } É

S^] Áæ^Á! •] { } ÖÁ ^ |Áæ^Á Á [, ^Áã & Áææ Áæ Á@ , Á æ & Á @æ |Áæ^Á | &ç Á | Áæ } •æ^Áæ |
 áæ çæ & ÖÖÖÖÖÖÖÖÖ ÖÖPS-B- 0005

Ö [{ U]!æ } Á &ç } ÁÉ

CD9F5HCB

⚠ DANGER

Read the manual before operating the machine. Failure to read the manual may result in injury or death. Please refer to the manual for more information.



⚠ WARNING

Use proper operation procedures to avoid accidents. Do not use the machine on uneven or slippery surfaces. Always use proper safety techniques.

⚠ DANGER

Always use proper operation procedures. Do not use the machine on uneven or slippery surfaces. Always use proper safety techniques.

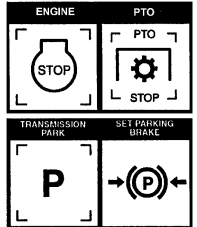

CD9F5HCB

CD9F5HCB

⚠ WARNING

Viaj •] [oA] | AaaA •] ^ a • A , @ | ^ A [^ ~ A & a { a } d [| A [- Ac @ ~ ~ q { ^ } dU | q ~ • A & & a) o } a b i a • A & a A • ^ | o A [{ }] | ^ a a * A @ ~ ~ q { ^ } o A A @ | A] ^ a • E V] a | • a @ A V / a e d | A a A Q] | ^ { ^ } o A } a @ , A a a | ^ • A a f | ^ A a a }] [i a * A] A d ^ o } a a a @ a e • E T a a A ^ | ^ A @ A / a e d | A o A i a * a a A i a a • A e ^ A A [[a A] a a } A a A] ^ a a A] | ^ | E



O A f | ^ A a a }] [i a * A @ A / a e d | A a A Q] | ^ { ^ } d U | q { a A o A |] | ^ | A a a }] [o A] ^ a • A f | ^ | ^ } a a @ A ~ ~ q { ^ } E T a a A ^ | ^ A [^ a a ^ A ^ A o A f]] , a * A ^ | • K

V • o A @ A i a e d | A a A] , A] ^ a a } a } & ^ a e ^ A @ A] ^ a a A] , | E V] | ^ A o A i a e ^ A { [[o @ d | A a a | { a ^ A o A f]] } a * A & a a e c | a e A ^ A c @ A / a e d | A a A Q] | ^ { ^ } d U | q A [^ A } & ^ a e ^ a @ A •] ^ a A f - A c @ A / a e d | A c @ A • d]] } a * A a a a } & A a } & ^ a e ^ • E V | o A | { a ^ A c @ A f a a ~ { d a a }] [o A] ^ a a [o A A e ^ a a e A] o A e A] o A i a a }] [i a * A @ A ~ ~ q { ^ } d E

V • o A @ A ~ ~ q { ^ } o A A] , A] ^ a a } a } • E V | o A ^ a e ^ A @ A] ^ a a A [* @ a @ A] } A] | ^ a e | ^ | ^ A a | { a ^ A o A a @ A ~ ~ q { ^ } o A a A A] ^ a e a a A a o | A] ^ a E V | ^ A o A f | ^ A e a a A a a ^ & A ^ | ^ A] ^ a A } @ } A } a * A @ a | ^ A f | ^ a } o A o A a e d | A a a a } | ^ { ^ } o A | { c }] } a * A f | o A | o A | { a ^ A o A f a a ~ { A } } a * A] ^ a A f | A [^ a a a @ A ~ ~ q { ^ } o A a f | ^] | ^ a a * A] A [a a } A i A } ^ a } A] | ^ | a E

U] | ^ A a a }] [o A @ A / a e d | A a A Q] | ^ { ^ } o A o A] ^ a • A } o A a] , A [^ A f | A] | ^ | ^ A } d |] o A ~ ~ q { ^ } d E

O A a e a a A - A o A] ^ a a * A] a a } • E V | A [o A] ^ a e ^ A c @ A / a e d | A a o A ^ a e A i a e | c A i a e • [| A []] A a • E V | o A } A] ^ a a * A] , } A o A i A } A o A i a e a | a A [a a • E V | o A i a e a * A a e } & a } & ^ a e ^ • K • ^ A c d | ^ A e a a a a a ^ & A [^ A] ^ a E V | o A } A] ^ a a * A i a e a a } , a • A • a c @ A / a e d | q A e @ * A a } a * A @ a } a a a a ^ & A [^ A] ^ a E V | o A a e a A i a e a a }] a A [^ a a a e a e ~ o A i A c o | A ^ ~ E V | o A } J D



CD9F5HCB

• % G H f b [^ h Y F U W t f

V @ A] | ^ a ^ | ^ A f | A e o A @ A i a e d | A a A [a a A] ^ a a e U a A | A f A c @ A i a e d | A] | ^ a e | q A } a } a f | A e a e *] | | ^ a ^ | ^ A f | A [^ | A e a e | a A e d | E V | o A } • | o A e a e c | a ^ a A a a e | A a a o A • a e d * A] | | ^ a ^ | ^ A a ~ } & ^ a e E V | o A } • ^ A c @ A e [a A e } d | A ^ o A i a e A c @]] , ^ | a a A [• a a } a a a @ A U V U / A a a ^ } a e a a A f | A • a e d * A c @ A i a e d | E V | o A } U - 0033



O { } U] ^ a a } A ^ & a } A e U

CD9F5 HCB

"&6 fU YUbX'8 JZyfYbhU' @cW`GYHjbI

T æ ^ Á ~ | ^ Á @ Á i æ d | Á i æ æ ^ Á æ ^ Á Á [[á Á] ^ i æ æ * & } á æ æ } È V i æ æ d | Á à i æ æ ^ Á æ æ Á à ^ Á ^ Á d Á] ^ i æ æ æ á æ ^ Á) á ^) d ^ Á æ [] , æ * Á æ * | ^ Á ^ Á æ Á , @ ^ | Á à i æ æ æ * æ æ æ } Á | Á | & ^ á Á * ^ c @ | Á d Á | [ç æ ^ Á æ ~ | æ ^ | ^ Á æ Á , @ ^ | Á à i æ æ æ * È Á Á U Ü Á T U Ü V Á Ö U Q X Q Ö Á C F Ö U U Ö U C Ö F Ö Á Ö U P Ö Ö Q W P Ù È V P Ö Á Ö U C S Ö Á Ö U Ö C S Ù Ù P U W S Ö Á Ö Ö Á U Ö S Ö Ö Á U Ö Ö V P Ö Ö Á U Á Ö U U X Ö Ö V P Ö Á T U Ü V Á Ö Ö Ö Ö V Q Ö Á Ö U C S Q Ö Á C F Ö V P Æ



Ö. æ • Á æ ^) * æ ^ Á @ Á i æ d | Á à æ ^ Á) æ æ Á | & Á @ } c | } æ * È Y @ } Á } * æ ^ á Á @ ^ Á à æ ^ Á) æ æ Á | & Á æ] | ^ ç ^) ö | Á | æ æ Á c @ Á d æ d | Á + | { Á c | } æ * È Ö ' i æ * } | { æ Á & ' ç æ * Á æ } á æ æ } • È | & æ * Á c @ Á à æ ^ Á) æ æ } | [ç æ ^ Á | Á ^ Á) ^ á Á æ á Á @ ^ | á Á | ç á Á ^ Á à È Á

OPS-U-0013

WARNING

Ó Á æ æ ^ Á ^ Á @ Á] ^ i æ æ * Á æ } á æ æ } • È Ö [Á [ö |] ^ i æ æ ^ Á @ Á i æ d | Á à c Á ^ á Á æ | c Á i æ æ ^ É Y @ } Á] ^ i æ æ * Á æ] , Á á Á | Á | Á] ^ ö | Á æ Á | æ Á | æ È @ Á i æ æ æ * Á á ç æ & Á æ & ^ æ ^ Á ^ Á ^ Á c d ^ { ^ Á æ æ Á æ á Á á ^ & Á [^ | Á] ^ á Á æ Á c @ ^ Á æ } á æ æ } • È Y @ } Á] ^ i æ æ * Á æ Á æ æ æ æ æ • Á ^ Á @ Á i æ d | ç Á æ @ } Á æ } æ * Á á @ Á æ á Á á ^ & Á [^ | Á] ^ á Á È Ó Á æ æ ^ Á Á i æ æ Á æ [^] á Á [^ Á æ á , æ æ ö | Á | Á @ Á i æ d | Á ^ Á ^ Á Ö Á Ops-0004-MISC)

DANGER

Ó Ö Ö U Ö Á æ æ * Á @ Á i æ d | Á ^ Á æ æ æ , æ • Á ^ Á @ Á æ æ æ * Á i æ æ Á æ æ á È | Á ^ c @ Á i æ d | Á d æ { æ • æ } Á æ Á æ æ æ * Á ^ Á æ È á á ^) * æ ^ Á c @ Á U V U È Á d | Á c @ ^) * æ ^ Á È ^ | [ç ^ Á c @ Á ^ È æ á Á æ æ Á | Á æ Á [ç æ * Á æ ö Á æ Á d] È Á U æ Á c @ d æ d | Á c @ ^ Á ç ^ Á i æ d | Á d æ | Á æ æ ^ Á | Á æ æ á * Á ^ Á æ Á | Á ^ ç ^) ö c @ Á i æ d | + | { Á | | æ * È Á ^ ç ^ Á | Á à [^] ö Á i æ d | Á c @ Á i æ d | [ç æ * Á | Á @ ^ Á c @ Á } æ á æ Á } } æ * È Á U ^ i æ æ ^ Á @ Á i æ d | Á æ } d | • Á | { Á @ Á i æ d | Á ^ Á æ } | È Ö Ö Á d

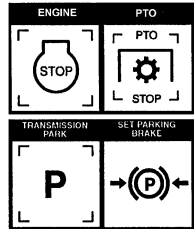

CD9F5HCB

." '8fjj]bl 'H YHfUWcf'UbX'6cca

Úcœdŉ -Ááíq̄ā * ÁœÁœÁ[[, Á] ^ááÁœ) áÁíœœ' œŉ' Áŉ & ^œ ^Á[ŷíÁ] ^ááÁ @ŉÁ œŉ œŉ ā * Áŉ {] | ^œÁŉ } d[|Á -Ác @ dœdŉ |ÉÁ ^ç^íÁ] ^íœ Ác@ Ácœdŉ |ÁœÁ ^á • ÁcœÁœœ } [œÁ Áœœ' Ácœ) áíáÁíÁ @œÁ q̄íÁ ^ç^) œ@Á] ^íœ : +[{ Áç]] ā * Á' œŉ' Áŉ íā * Áŉ Á { ^í^) & ÉœÁc@Á [, ^íÁ œ'íā * ÁíÁ) * ā ^Áœ ^œ ^Á] ^íœœ * ÉÁç] Ác@ Ácœdŉ : ā { ^áœœ' Áœ Ác@ Ácœdŉ |Á q̄íÁ Áŉāœ |œŉ' Áŉ } d[|É

Úŉíŉ{ { Áç } } • Á ŉœœ@ Ácœdŉ |Áœ) áÁ [, ^íÁœÁ[[, •] ^á • Áç Áŉœŉ { ā ^Ác@ , Ác@ Ácœdŉ |Á, ŉœÁœ) á œœœ@ áÁŉ] | ^) œ'œœ) áí • Áœœ' } Éœœœ' { ā ^Ác@ • œœÁ] ^áÁŉ' Á' œŉ œŉ Á [] ^íÁŉ } d[|Á -Ác@ Ácœdŉ | , @ } Á { œā * Áç } } • ÉÁ Y @ } Áç } } ā * Á ŉœœ @ œ] | ^) œ'œ@Á ç'íœŉÁ [íā * Áŉ) * œœœ) áÁ ŉœœŉ - œ@Á' ŉœœ' Áŉ & ^œ ^áÉœŉ[, Áœááœŉ } œŉ' ^œœœ & Áŉ : œ@Á' ŉœÁ, @ } Áç } } ā * ÁíÁ, @ } Á) œ • ā * Áíœ * ^ [à • d' & ç] • É



V[Áœç[ŉáŉ ç'íç } } • ÉÁíq̄ā ^Ác@ Ácœdŉ |Á ŉœœœ ^Áœ) á œœÁ œœÁ] ^á • ÉÁœ] ^áœŉ' Á, @ } Á [] ^íœœ * Áŉ ç'í : [ŷ * @ * í [ŷ) áÉ&[• • ā * Ááœœ@ • ÁíÁ • [] ^œ Éœ) á ç } } ā * Á & ç } } ^í • ÉÁ W ^Á ^çd^ { ^Á œœ ç } } Á, @ } [] ^íœœ * Á' Áç^) Á [] ^œ Éœœ^) Ác@ Ácœdŉ |Á Áŉŉ , * ^œÁ @ } Á' [ā * Áŉ [, } @ÉÁœŉÁ UVÁŉ œŉ' íÁí^É , @ŉ' Áŉ [, } @ŉÉ

OPS-B- 0006

CD9F5HCB

ŉ [{ U] ^íœœ } Áŉ&ç } ÁÉF

CD9F5HCB

▲ WARNING

Ինչպես օգտագործել սեղանի համակարգը, օգտագործելու ժամանակ միշտ պահպանել համակարգը կայուն վիճակում:
 [օգտագործելու ցուցանիշները տեսնել համակարգի օգտագործման ցուցանիշներում]:



▲ DANGER

Սեղանի վրա աշխատելու ժամանակ միշտ պահպանել համակարգը կայուն վիճակում:
 օգտագործելու ցուցանիշները տեսնել համակարգի օգտագործման ցուցանիշներում:
 Սեղանի վրա աշխատելու ժամանակ միշտ պահպանել համակարգը կայուն վիճակում:
 [օգտագործելու ցուցանիշները տեսնել համակարգի օգտագործման ցուցանիշներում]:

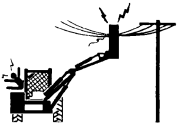

- "CD9F5HB; H<9'6 CCA' I B#5 B8 '5H5 7 <98 ' <958

H<9' CD9F5HCF' AI GH' 7CAD@H9 @M I B89FGH5B8' <CK' HC' CD9F5H9' H<9'HF5 7HCF' 5B8
 ACK 9F' 5B8 '5 @7 CBHFC @G'9: CF9'5HH9ADHB; 'HC'ACK "AV@A'] Վառարկայի կիրառումը: Սեղանի վրա աշխատելու ժամանակ միշտ պահպանել համակարգը կայուն վիճակում:
 օգտագործելու ցուցանիշները տեսնել համակարգի օգտագործման ցուցանիշներում:
 Սեղանի վրա աշխատելու ժամանակ միշտ պահպանել համակարգը կայուն վիճակում:

Սեղանի վրա աշխատելու ժամանակ միշտ պահպանել համակարգը կայուն վիճակում:
 օգտագործելու ցուցանիշները տեսնել համակարգի օգտագործման ցուցանիշներում:
 Սեղանի վրա աշխատելու ժամանակ միշտ պահպանել համակարգը կայուն վիճակում:
 [օգտագործելու ցուցանիշները տեսնել համակարգի օգտագործման ցուցանիշներում]:

Սեղանի վրա աշխատելու ժամանակ միշտ պահպանել համակարգը կայուն վիճակում:
 օգտագործելու ցուցանիշները տեսնել համակարգի օգտագործման ցուցանիշներում:
 Սեղանի վրա աշխատելու ժամանակ միշտ պահպանել համակարգը կայուն վիճակում:

Սեղանի վրա աշխատելու ժամանակ միշտ պահպանել համակարգը կայուն վիճակում:
 օգտագործելու ցուցանիշները տեսնել համակարգի օգտագործման ցուցանիշներում:
 Սեղանի վրա աշխատելու ժամանակ միշտ պահպանել համակարգը կայուն վիճակում:
 [օգտագործելու ցուցանիշները տեսնել համակարգի օգտագործման ցուցանիշներում]:

▲ WARNING

Օգտագործելու ցուցանիշները տեսնել համակարգի օգտագործման ցուցանիշներում:
 Սեղանի վրա աշխատելու ժամանակ միշտ պահպանել համակարգը կայուն վիճակում:

▲ WARNING

Սեղանի վրա աշխատելու ժամանակ միշտ պահպանել համակարգը կայուն վիճակում:
 օգտագործելու ցուցանիշները տեսնել համակարգի օգտագործման ցուցանիշներում:
 Սեղանի վրա աշխատելու ժամանակ միշտ պահպանել համակարգը կայուն վիճակում:
 [օգտագործելու ցուցանիշները տեսնել համակարգի օգտագործման ցուցանիշներում]:

©2013 Alamo Group Inc.

CD9F5HCB

CD9F5HCB

CD9F5HCB

- "G i Hbf '8ck b' h Y5 HUW YX< YUX!': cf' GfubXUF'9ei]da Ybh

V[Á @ oÁ[,) Áææ@áÁ [, ^!Á@ææÉá•oÁiá * Á@ dæd[ÁÁ ÁæÁ {] |ÁÁÁ d] ÉÖ^ & ^æ^Á * á ^ÁÚÚT d ÁiÁÁ@) Áá^ * æ^Áæ^ Á @æÉV@Á [, ^!Á@ææ , áÁÁ { ^ÁÁ ÁÁ & {] |ÁÁÁ d] Á , æ@ Ááá ~ ææ|Á æ [~] oÁ ÁÁ ^ÉÖ[Á [oÁ * æ^Á!Áá^ * æ^Á@ & ^! @æ•ÁæÁæÁ@ @ÁÚÚT Á } |Á•Á@!ÁÁá Áæ) ^{ ^! * ^} & Á áæ } É



On-Off Switch

Úæ\ Á@Áæ æd[Á [] ÁáÁ^ÁÁ^! æÁÉ] |æÁ@ dæ•{ á•á } ÁáÁ] æÁ[Á] ^ dæÁæ áÁæ] |Á@] æá * Ááæ^É@ oÁ[,) Á@Á * á ^ÉV{ [Á@ ^ÁÉæ áÁ æÁÁ | ÁÁ [Á] ÁÁ & { ^Á ÁæÁ {] |Á • d] ÁÁ^! ^ÁÁá * Á@ Áæd[É OPS-B-0011_D



OOZUOÁæá * Á@ Áæd[ÁÁæÉæ, æ•Á^Á@Áæ] á * Ááæ^Áá áÉ: Á^c @Áæd[ÁÁæ•{ á•á } Áá Á] æá * Á^æÉáá^ * æ^Á@ÁÚVÉÁ d] Á@ ^} á ^ÉV{ [Á@Á^Éæ áÁ æÁÁ | ÁÁ [Á * ÁæÁÁ ÁÁ] ÉÁ]æÁ@ dæd[Á @ÁÁÁÁ d ÁÁ, Áæ * ÁÁ Á] æá * Á^æÁÁ Á ^Á^ oÁÁæd[: { Á [] á * ÉÁ^ÁÁ { [~] oÁÁæd[Á@ÁÁ [Á * ÁÁ @ÁÁ * á ^ áÁ } } á * ÉÁ] ^!æÁ@Áæd[ÁÁ] d [|Á [{ Á@Áæd[ÁÁæ }] ÉÚÖÉD

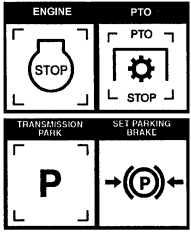

Ó [{

U] ^!æá } Á^&á } ÁÉU

CD9F5HCB

CD9F5HCB

%%%D`UWb['6cca '5fa 'cb'6cca '5fa 'FYgh!': cf'GHbXUX'9ei]da Ybh

Ó^f|^Átæ•][|ç * Átædq |Á^c ^^^ Á[&æq } • Éñ |
 c@Átædq |Á} * ã ^Éñã^ * æ^Ác@Áææ&@áÁ@æáÉ
 æ} áÁ æñÁ |Áñ|@æáÁ [ç] Á[Á[{ ^Á[Áæ[{]|^c
 • d] ÉÁU|æ^Ác@ Áá[{ Á[Á• Á d |æ^Á&æñ|^Á^c
 • }]] | | ç] áÁc@ } Á ; } Ác@Á^ • æÁ Á æc^Á, æ&@Á
 c@ÁUØÁ [• æ] } ÉÁ



" Ü^dæcÜ^& ÁU[| | & | ç] áÁ^Á[{]|^c|^É
 " Ü • @Ü^& } áæ^ & | ç] áÁ^Á[] | | ç] æ|^ ÁÉDÁ
 , æÁ ~ É
 " Üæ^ÁT æñ Á[[{ Á[] | | ç] æ|^ Á Á ÉÉ
 " Ü, ã * Á[[{ ÁæÁ Á [, |^Á } ç] ÁÁ Á dææ @Á
 áæÁ É
 " Q | ÁÁÉ | ç] ç[[{ |^•ç | ÁÁ ã * |^Á[| { } Á
 à [[{ |^•ç [• æ] } Ác@Á^& } áæ^ Ác@Á
 & æñ|^ÉÜæ^~ | | Áæ[æÁ ã & @ * Á[^ÁQ • ^ • É
 " Q | ÁÁ | ^) Á d , Ác|^Á[[{ |^•ç | , ^Ác@Á
 T æñ Á[[{ Á } ç] Á^•ç} áÁ ã * Ác@Á^& } áæ^ Á
 à [[{ Á Á } ç] ÁÁ Á æ] * Á } Ác@Á[[{ |^•ç
 " Q | ÁÁ^* æÁUd , Ác|^Á[[{ |^•ç|^dæc@Á
 • ^& } áæ^ Á[] } & |^& | ç] áÁ^Á[{]|^c|^ÉÁ
 Š , ^Ác@ÁT æñ Á[[{ Á } ç] Á^•çU[, |^Á
 ^c) áÁc@Á^& } áæ^ & | ç] áÁ^Á } ç] Ác@Á
 • ^& } áæ^ Á[[{ Á[] dæc@Ác@Áæ^Á Ác@Á[[{ |^•çæá|^ÉÜ^cÉ [, |^Ác) áÁc@Á } & |^& | ç] áÁ^Á } ç] Á
 c@Á^& } áæ^ Á^c@Á } Ác@Á[ç] { Á æç^Ác@Á[[{ |^•çæá|^É



V@Á[[{ Á Á [, Á Ác@Áæ}] | | ç] [• æ] ÉV | } Á } Á^Á^&c[] æÁæ|^Á[& • ÁÁc@Á, æ&@ [çÉ
 V | Á^ [ç^Ác@Á[[{ Á[{ Ác@Á[[{ Á^•çÁ^•ç } Á - Á^Á^&c[] æÁæ|^Á[& • ÁÁc@Á, æ&@ [ç] Á^dæc
 c@Á } & |^& | ç] áÁ^Á[] | æñ|^D@ } Á, ã * Ác@Á^& } áæ^ Á[[{ Á ~ ÉÜæ^Ác@ÁT æñ Á[[{ Á[] | | ç] æ|^ Á
 ã & @ • ÉÜ, æ^Ác@Á[[{ Á | , æáÁ Ác@Á^•áá[• æ] } ÉÜOPS-B-0013_D

Ó[{ U|^æ] } Á^&ç } ÁÉ F

CD9F5HCB

CD9F5HCB

OPS-U-0024

OPS-U-0024



Op - 46

⚠ DANGER

OPS-U-0024

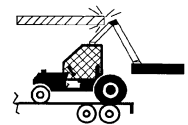

OPS-U-0025



Op-47

OPS-U-0025

OPS-U-0025

CD9F5HCB

CD9F5HCB

OE:æ *^Ác@Á&@æ•Á•[Ác@æÁ, @}Áæ @^}^áÆÁc@
 &@æ•Á æ^Á~||æ *Á[], æáÁ æ áÁ æ ææ•c
 c@{•^|ç^•ÆÁæ^~||^Áæ @^}Ác@Á^&|æ *Á&@æ•Á!
 [c@!Áææ^}^Á•Á•æ *Áæ[[{^Á•Á!Áææ á^Á•Áç] |
 {ææ~{Á^}•æ}ÆÁÁ^Áææ^ {^Á&æ^Á, @}
 æææ@ *Áæ áÁ^ { çæ *Ác@Á^&|æ *Áæçæ^Áæ Ác@
 ^ææ{^Áæ}•æ}Áæ ç|ç^áÁ, @}Á^|ææ^áÁæ Ác@
] |ç}æææ æ ææ^Áæ~•ææ^i^É



Y @^Áæ |æ *Ác@Áææç!Áæ áÁæ] |ç{^}æ^
 [ææææ]æ^ç]•Áç Á&@&Ác@æÁc@Áææç!Áæ á
 æ] |ç{^}æ^æ^Á[ç^áÁ!Áæ ææáæ áÁc@æÁc@
 •^&|æ *Á&@æ•Áæææ^áÁ^}•æ}ÆÁÁ^!æ *
 çæ•][ç^ææáÁæææ *Æææ]Áç!}æ *Æ!Á, ^|çæ *
 æææ] Áææ^|ç{^áÁæç]æææ^Á^æææ^Áæææ
 ç æ•] ^&æ^Á^&|æ^Á^æ^ÁææOPS-U- 0026

CAUTION

Qææ^ÁæÁ[ç^Á^&ç^Áç^|æ@Á[[{Áæ]áÁæ, æá•Ác@Á, ^Áææ^Æææ^Ác@!
]^•[}]^Áææ^Áæ]ç|ÁæÁ, æ *æ *Á [ç] Á @}Áæ|æ á^Áæ ÁæÁ^ { ç^áÁæ æ^Á^!Ác@
]^•[}]^Áæ^Á [ææ]•ææ}Áæ^Áæ^Áæ^•@áÁæÁ, æ *æ *Á[[{Æ

Ü^ææÁ, æ^|æ|æ á^Áæ áÁ&|æ^Áæ ææ Áææ ^ÆÁæ[ç^] Á!, æáÁæ Ác@Á^}ç!Áæ ÁææáÁæ, ^Áæ&Áæ] ç
 c@Áææ^Áæ^áÁæ áÁ @ç^Ác@Áæç |Æ^@Áææç!æ áÁc@Á [, ^Ác@ææÁ @^|áÁ [, Á^Á&æ^áÁæ [, }Á^&|æ^
 ç Ác@Áææ^Áæ^áÁæ

CAUTION

Qææ^Áææ^Ác@Á^}ææ *Á^&ç]Æ!Áæ^Ác@!Á^&ç]Á^Ác@Áææ^Áæ[ç^] |ç^
 ~}á^•ç [áÁæ]ææ[~!Áæ^Áææ^Á!Ác@Áææá^•Á]Ác@Áæç^Á!Ác@Áææ^Áæ^
 æ•ææ&^Á

Ó[[{ U] ^|ææ } Á^&ç } Áæ í

CD9F5HCB

CD9F5HCB

Ó[{

U] ^! aã } Á^ &ã } ÁË î

MAINTENANCE SECTION

T aq c} a} &^Á^&ç } Á È

MAINTENANCE

WARNING

Do not use the engine for any purpose other than the one intended. The engine is designed to operate only as a power source for the equipment it is used on. Do not use the engine for any other purpose.

WARNING

Do not use the engine for any purpose other than the one intended. The engine is designed to operate only as a power source for the equipment it is used on. Do not use the engine for any other purpose.

DANGER

Do not use the engine for any purpose other than the one intended. The engine is designed to operate only as a power source for the equipment it is used on. Do not use the engine for any other purpose.

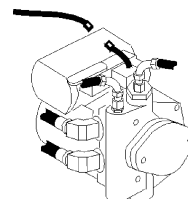

MAINTENANCE

MAINTENANCE OF CRANKSHAFT ADAPTER ASSEMBLY (RIGID ENGINE MOUNT TRACTORS ONLY)

Check the crankshaft adapter assembly for wear and damage. If any wear or damage is found, replace the adapter assembly. Do not use the adapter assembly if it is worn or damaged. Refer to the maintenance manual for more information.

(ASM-JD-0051 CRANKSHAFT ADAPTER MAINTENANCE)

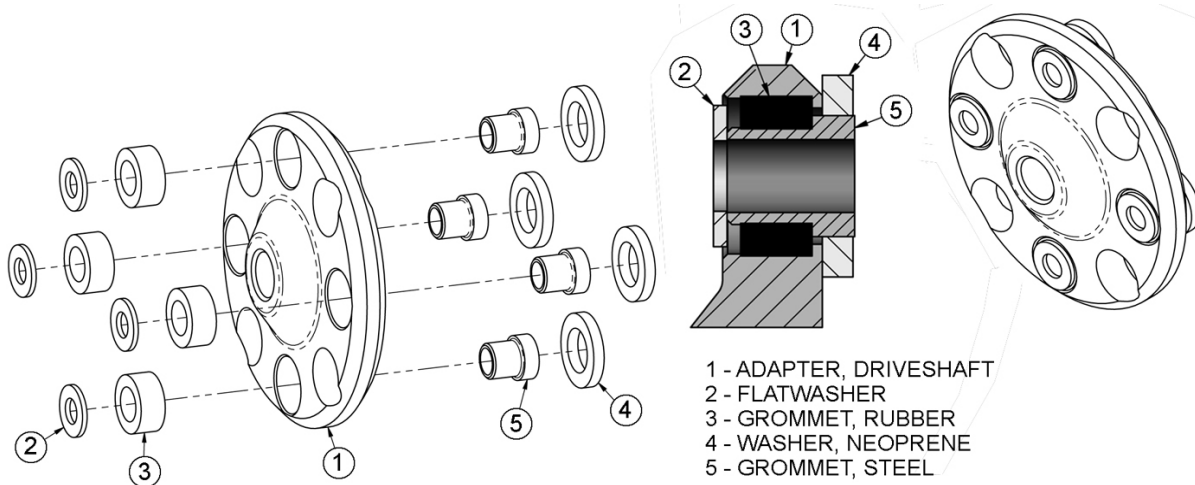

MAINTENANCE

MAINTENANCE

Regular Maintenance

V@/Á c|çap Á@Á @Á^* |æÁ^|çæá *Á @ |áÁ^Á | ^ÁÁ^Áæ^ÁÁ } Á@ | Á-Á | ^|æá } ÉÁ^Á@ Áæá | Á@ | { ^ÁÁ Á^Á | á^Á @ } Á^* |æÁ^|çæá *Á Á^~ á^áÉ

Ü^Á | Á@ Á@ Á^c æ^áÁT æá c } æ & Á^Á &ç } Á | Á^ c@ | Áá • d~ &ç } •Á } Á^ | æá * ÉÁ@ | ^Áæ áÁ • Á@ ÁÖæá T æá c } æ & Á @ ^Á | æá áÁ@ Á } áÁ Á@ Á^ &ç } É

Daily or Every 8 Hours

QÒT Á	ÜÖÜXÒ	ÔUTT ÒPVÜ
Ö:æ^Á@æÁ ^ÉÁÉ á c BÁÜc àÁ@æ	Ö:æ^	Ö:æ^Á@æ Á • d~ &c á/á á^æá áÁ æá c } æ & Á^ &ç }
Ü {] ÁÖ:æ^Á@æÁ [~] ^	Ô@ & Á áÁ^ á^	Q • ^Á æ^ • @æÁ } áÁ æ
Ö:æ • @æÁ æá c Á	Ô@ & Á^ áá^Á [{ ^	Ü^ æÁ [{ ^ ÁÁ áæ æ^ áÁ Á á • á^ *
Üæ [cÁ á c	S~ à ææ	Qb &c ^æ^Á } ç/ç æ ^æ • ÁÁ } á
P^ á æ æÁ çá * Á	Ô@ & Á Á^ á •	Vá @ } Á @ } Á^ áááÉÁ Á cÁ • Á@ á • ç &c & Á Á^ á • É^ Á æá ç ^ææ ç } •
S æ^ Á Á	Ô@ & Á	Q • ^ & Á Á á • á^ Á Áæ æ^ áÁ } æ^ • É &c ^ Á Á^ ááÉ
Ü á á^ Á [~ ç * Á •] á á^ Á Á & D	Ô@ &	V ~ ^ Á Á Á^ á • É^ à ææ á V ~ ^ Á Á Á^ á • É^ í
S æ Á [~] ç * Á Q æ Á Á á Á Á æ^ Á æ D	Ô@ &	Ü ^ É^ à ææ Á @ ^ æá • Á á@ ç á^ á ç ~ ^ Á Á @ Á^ á • É
Öá \ É æá Á æ Á [~] ç * Á Qá \ É æá Á æ Á Á] á ^ D	Ô@ &	V ~ ^ Á Á Á^ á • É^ à ææ á V ~ ^ Á Á Á^ á • É^ í
Ó c	Ô@ & Éá b • c	Ô@ & Á Á Á^ ^ } Éá @ } Á Á^~ á^ á
T æ Á æ^ Á á Ö^ &	Ô@ & Á	Ü^ ç ~ ^ Á c Á Á ~ ^ • ^ áææ } • Á Á@ Á^ &ç }
P^ á æ æÁ çá æÁ^ ç	Ô@ &	Éá áÁÁ^~ á^ áÁ Á æÁ & [{ ^ } áæá } •
Ü^ á Á æÁ Ö:æ^ Á æá ^ D Ö^ á Á æ^ Á áÁ @æÁ [~] ^	S~ à ææ	Ö:æ^ Á@æ Á • d~ &c á/á á^æá áÁ æá c } æ & Á^ &ç }
Ö^ c Á Á @æÁ á Á	S~ à ææ	Ö:æ^ Á@æ Á • d~ &c á/á
Ó [{	T æá c } æ & Á^ &ç } Á É	

MAINTENANCE

MAINTENANCE

Ö: [] } aÄU [] | }

â^æ^âÄ æ } æ & ^Ä^&ç }

WEEKLY OR EVERY 40 HOURS

ÖÖT / UÜXÖÖ / ÖUT T ÖP VÜ

Ü [æ^ Ä] a | ^

Š^ à | ææ

Öç^ ^ Ä Ä @ ^ | • Ä | Ä ^ | ^

WEEKLY OR EVERY 50 HOURS

ÖÖT

ÜÜXÖÖ

ÖUT T ÖP VÜ

Ö Ä æ \ Ä ^ a Ä Ç ^ æ
Ö ç :
10 micron filterD

Ö @ ^ * ^

Ö @ ^ * ^ Ä ç : Ä a • Ö Ä Ä
@ ^ | • Ä | ^ | • Ä | Ä ^ | ^
í Ä Ä @ ^ | • Ä | Ä ^ | ^

Ö Ä æ \ Ä ^ a Ö Ü | ^ • • ^ | ^
Ö ç :
10 micron filterD

Ö @ ^ * ^

Ö @ ^ * ^ Ä ç : Ä a • Ö Ä Ä
@ ^ | • Ä | ^ | • Ä | Ä ^ | ^
í Ä Ä @ ^ | • Ä | Ä ^ | ^

MONTHLY OR EVERY 150 HOURS

ITEM

SERVICE

COMMENTS

P^ à | æ | Ä Ç ^ æ | S^ Ç ^ | Ä

Ö @ &

Ö a a Ä Ä ^ a ^ a

P^ a Ä V æ \ Ä Ö | ^ æ @ :

Ö | ^ æ | • | Ä ^ | ^ | æ &

Ö | ^ æ | Ä | Ä ^ | ^ | æ &
^ | ^ { ^ } Ö Ä ^ ~ a ^ a

Ü^ æ Ä a ^ Ä ^ | ^
| | • • • Ü H |
F | Ë È |
F | Ë È |

T æ Ä Ü È È È
Ä Ä Ä
Ä Ä Ä
Ä Ä Ä

YEARLY OR EVERY 500 HOURS

ITEM

SERVICE

COMMENTS

Ü j a | a ^ Ä | ^ æ ^
P^ a Ä V æ \ Ä Ç ^ æ
Ö Ä æ \ Ä ^ a Ä Ç ^ æ Ä ç :
10 micron filterD

Ö @ ^ * ^

Ö @ ^ * ^

Ö @ ^ * ^

Ö Ä æ \ Ä ^ Ü Ä ç :
10 micron filterD

Ö @ ^ * ^

Ä Ä :

Ö @ ^ * ^ Ä @ } a a æ a
a ^ Ä ^ d æ ç } a a æ | È

P^ a Ä V æ \ Ä Ö | ^ æ @ :

Ö @ ^ * ^

Ö [] {

T æ ç } æ & ^ Ü ^ & ç } Ä È

MAINTENANCE

TROUBLESHOOTING





ÙŸT ÚVUT Ò	ÔÇWÙÒ	ÙÒT ÒÖŸ
Vibration	FÉŠ[[• ^ ÁŠ [Ç ÇËÖ ¸ ÁŠ • ^ { à ÁÁ } à a a } & ^ á	FÉWÖ @ & ÁŠ ÁŠ [Ç ÁŠ à ÁŠ Ç } ÁŠ ÁÁÁÁ ^ ÁŠ { { ^ } à ^ á ÁŠ ~ ^ Á } ^ & • È ÇÉÖ @ & ÁŠ ÁŠ ÁŠ ¸ ^ á ÁŠ ÁŠ ^ ÁŠ ÁŠ & ÁÁÁÁ ÁŠ ¸ • Ç ÉÁÖ ÁŠ ÁŠ ^ ÁŠ á Á È ÇÉÖ @ & ÁŠ ÁŠ à ÁŠ ÁŠ ÁŠ & È ÁÁÁÁ } Ç } ^ á ÁŠ ÁŠ Ç ÁŠ ¸ ÁŠ • ^ { à
Mower will not lift	FÉP ^ á ÉÖ ¸ Á ÁŠ ÇÉÁ ¸ a ^ ÁŠ ÁŠ ^ ÜUW HÉÇ ¸ Ç ÁŠ a ^ ÁŠ ç ^ Í ÉÇ ¸ Ç ÁŠ a ^ ÁŠ	FÉWÖ @ & ÁŠ ÁŠ á ÁŠ Ç ÁŠ á ÁŠ ¸ ÁŠ ÇÉÁÖ @ } ÁŠ ÁŠ ÁŠ ÁŠ ÁŠ ¸ • ÁŠ á ÁŠ Ç • ÁŠ HÉWÖ @ & ÁŠ ÁŠ • ^ ÁŠ ÁŠ ^ ÁŠ ÁŠ ÁŠ ÁÁÁÁ ÁŠ • ^ ÁŠ ÁŠ d ÁŠ ÁŠ ÁŠ Ç ^ ÁŠ ÁŠ ÁÁÁÁ ÁŠ ¸ Ç Ç ÁŠ ÉÁ ÉÉ ÉÉ Í ÉÁÖ Ç ÁŠ & Ç ÁŠ ÁŠ ÁŠ ÁŠ a ^ ÁŠ
Mower will not start or run	FÉÖ [, } ÁŠ • ^ ÇËÖ ÁŠ ÁŠ ÁŠ • ÁŠ [• ^ á HÉŠ [, ÁŠ ÁŠ Ç ^ Í ÉŠ ÁŠ ^ ÁŠ a	FÉWÖ @ & ÁŠ • ^ ÁŠ Ç ^ ÁŠ ÁŠ [, ^ ÁŠ , ÁŠ Ç ÁŠ ÁÁÁÁ ÁŠ á ÁŠ } ÁŠ } ÉÁ ÁŠ ÁŠ ÇÉÁÖ ¸ a ^ ÁŠ ^ ÁŠ ÁŠ ÁŠ • ÁŠ ^ ÁŠ ÁŠ HÉWÖ @ & ÁŠ ÁŠ á ÁŠ ÁŠ ÁŠ ÁŠ ÁŠ Í ÉÁÖ @ & ÁŠ ÁŠ ÁŠ ¸ • ÁŠ á ÁŠ ÁŠ • È ÁÁÁÁ ÁŠ ÁŠ Ç } ÁŠ ÁŠ ÁŠ ÁŠ Í ÁŠ ÁŠ ÁŠ Ç ^ ÁŠ ÁŠ ÁŠ ÁŠ } ÁŠ • ÁŠ ÁŠ ÁÁÁÁ Ç ÁŠ [, ^ ÁŠ , ÁŠ Ç ÁŠ ÁŠ ÉÁÁ ÁÁÁÁ ÁŠ á ÁŠ ÁŠ ÁŠ ÁŠ Ç ^ ÁŠ ÁŠ Ç ÁŠ Ç ÁŠ ÁŠ Ç ÁŠ ÁÁÁÁ ÁŠ ÁŠ ÁŠ ÁŠ } ÁŠ ÁŠ ÁŠ ÁŠ ÁÁÁÁ [] ÁŠ ÁŠ ÁŠ ÁŠ ÁŠ Ç ÁŠ ÁŠ ÁŠ ÁÁÁÁ , ÁŠ Ç ÁŠ } ÁŠ ÁŠ } ÁŠ á ÁŠ á Ç ÁŠ ÁÁÁÁ & ^ , á ÁŠ ÁŠ Ç ÁŠ Ç ^ ÁŠ á Ç ÁŠ & È ÁÁÁÁ ÁŠ ^ Ç ÁŠ Ç { ÁŠ ÁŠ ^ ÁŠ } á ÁŠ ÁŠ Ç ÁŠ ÁÁÁÁ ÁŠ ÁŠ ÁŠ Ç ÁŠ ^ Ç ÁŠ ÁŠ á Ç ÁŠ ÁŠ Ç ÁÁÁÁ ÁŠ ÁŠ Ç ÁŠ ÁŠ ÁŠ Ç ÁŠ Ç ÁŠ Ç ÁŠ Ç ÁŠ ÁÁÁÁ ÁŠ á ÁŠ á ÁŠ ÁŠ ÁŠ ÁŠ ÁŠ Ç ÁŠ ÁŠ Ç ÁŠ ÁÁÁÁ á Ç ÁŠ ÁŠ ÁŠ ÁŠ Ç ÁŠ Ç ÁŠ Ç ÁŠ Ç ÁŠ ÁÁÁÁ Ç ÁŠ ÁŠ ÁŠ ÁŠ Ç ÁŠ ÁŠ ÁŠ È Í ÁŠ ÁŠ ^ [Ç ÁŠ Ç ÁŠ ^ ÁŠ Ç ÁŠ ÁŠ ÁŠ Ç ÁŠ ÁÁÁÁ { ÁŠ ÁŠ & ÁŠ ÁŠ ÁŠ ÁŠ ÁŠ ÁŠ ÁŠ Ç ÁŠ ÁÁÁÁ ÁŠ ÁŠ [Ç ÁŠ { ÁŠ ÁŠ & ÁŠ ÁŠ Ç ÁŠ ÁÁÁÁ ÁŠ ~ ÁŠ ÁŠ ÁŠ ÁŠ Ç ÁŠ ÁŠ ÁŠ Ç ÁŠ ÁÁÁÁ Ç ÁŠ ÁŠ Ç ÁŠ ÁŠ ÁŠ ÁŠ Ç ÁŠ Í ÁŠ ÁŠ ^ [Ç ÁŠ ÁŠ Ç ÁŠ ^ ÁŠ } ÁŠ ÁŠ ÁŠ ÁŠ Ç ÁŠ ÁÁÁÁ ÁŠ ÁŠ ÁŠ & ÁŠ ÁŠ ÁŠ ÁŠ ÁŠ á ÁŠ • ÁŠ ÁÁÁÁ ÁŠ ÁŠ ÁŠ • ÁŠ Ç ÁŠ ÁŠ ÁŠ ÁŠ ÁŠ ÁŠ ÁÁÁÁ á ÁŠ ÁŠ ÁŠ ÁŠ ÁŠ ÁŠ ÁŠ ÁŠ ÁÁÁÁ ÁŠ } ÁŠ } ÁŠ Ç ÁŠ ÁŠ ÁŠ Ç ÁŠ Ç ÁŠ • È

MAINTENANCE

Ó [{ T ÁŠ Ç } ÁŠ & ÁŠ Ç } ÁŠ È

MAINTENANCE

MAINTENANCE

Torque for Standard Fasteners													
Nominal Dia. (in.)	threads per inch	 Grade 2			 Grade 5			 Grade 8			 Grade 9		
		Tightening Torque			Tightening Torque			Tightening Torque			Tightening Torque		
		Lubed	Dry Plated	Dry plain	Lubed	Dry Plated	Dry plain	Lubed	Dry Plated	Dry plain	Lubed	Dry Plated	Dry plain
		K = 0.15	K = 0.17	K = 0.20	K = 0.15	K = 0.17	K = 0.20	K = 0.15	K = 0.17	K = 0.20	K = 0.15	K = 0.17	K = 0.20
Unified Coarse Thread Series													
1/4	20	49 in-lbs	59 in-lbs	66 in-lbs	76 in-lbs	86 in-lbs	101 in-lbs	107 in-lbs	122 in-lbs	143 in-lbs	126 in-lbs	143 in-lbs	168 in-lbs
5/16	18	101	122	135	157	178	209	221	251	295	259	294	346
3/8	16	15 ft-lbs	18 ft-lbs	20 ft-lbs	23 ft-lbs	26 ft-lbs	31 ft-lbs	33 ft-lbs	37 ft-lbs	44 ft-lbs	38 ft-lbs	43 ft-lbs	51 ft-lbs
7/16	14	24	29	32	37	42	49	52	59	70	61	70	82
1/2	13	37	44	49	57	64	75	80	90	106	94	106	125
9/16	12	53	63	70	82	92	109	115	130	154	135	153	180
5/8	11	73	87	97	113	128	150	159	180	212	186	211	248
3/4	10	129	155	172	200	227	267	282	320	376	331	375	441
7/8	9	125	150	167	322	365	429	455	515	606	533	604	710
1	8	187	225	250	483	547	644	681	772	909	799	905	1065
1 1/8	7	266	319	354	596	675	794	836	966	1288	1132	1283	1510
1 1/4	7	375	450	500	840	952	1121	1173	1363	1817	1597	1810	2130
1 1/2	6	652	783	869	1462	1657	1950	2041	2371	2688	2317	2779	3306
Fine Thread Series													
1/4	28	56 in-lbs	68 in-lbs	75 in-lbs	87 in-lbs	99 in-lbs	116 in-lbs	123 in-lbs	139 in-lbs	164 in-lbs	144 in-lbs	163 in-lbs	192 in-lbs
5/16	24	112	135	150	174	197	231	245	278	327	287	325	383
3/8	24	17 ft-lbs	20 ft-lbs	23 ft-lbs	26 ft-lbs	30 ft-lbs	35 ft-lbs	37 ft-lbs	42 ft-lbs	49 ft-lbs	43 ft-lbs	49 ft-lbs	58 ft-lbs
7/16	20	27	32	36	41	47	55	58	66	78	68	78	91
1/2	20	41	49	55	64	72	85	90	102	120	105	120	141
9/16	18	59	71	78	91	103	121	128	146	171	151	171	201
5/8	18	82	99	110	127	144	170	180	204	240	211	239	281
3/4	16	144	173	192	223	253	297	315	357	420	369	418	492
7/8	14	138	165	184	355	403	474	502	568	669	588	666	784
1	14	210	252	280	542	614	722	765	867	1020	896	1016	1195
1 1/8	12	298	357	397	668	757	890	1083	1227	1444	1269	1439	1693
1 1/4	12	415	498	553	930	1055	1241	1509	1710	2012	1768	2004	2358
1 1/2	12	734	880	978	1645	1865	2194	2668	3024	3557	3127	3544	4169

Torque values for 1/4 and 5/16-in series are in inch-pounds. All other torque values are in foot-pounds. K = 0.15 for "lubricated" conditions
 Torque values calculated from formula T=KDF, where K = 0.17 for zinc plated and dry conditions
 K = 0.20 for plain and dry conditions D = Nominal Diameter
 F = Clamp Load

Torque-Tension Relationship for Metric Fasteners													
Nominal Dia. (mm)	Pitch	Class 4.6			Class 8.8			Class 10.9			Class 12.9		
		Tightening Torque			Tightening Torque			Tightening Torque			Tightening Torque		
		Lubed	Dry Plated	Dry plain	Lubed	Dry Plated	Dry plain	Lubed	Dry Plated	Dry plain	Lubed	Dry plain	
		K = 0.15	K = 0.17	K = 0.20	K = 0.15	K = 0.17	K = 0.20	K = 0.15	K = 0.17	K = 0.20	K = 0.15	K = 0.20	
3	0.5	0.28	0.32	0.38	0.73	0.82	0.97	1.0	1.2	1.4	1.2	1.6	
3.5	0.6	0.44	0.50	0.59	1.1	1.3	1.5	1.6	1.9	2.2	1.9	2.5	
4	0.7	0.66	0.74	0.87	1.7	1.9	2.3	2.4	2.7	3.2	2.8	3.8	
5	0.8	1.3	1.5	1.8	3.4	3.9	4.5	4.9	5.5	6.5	5.7	7.6	
6	1	2.3	2.6	3.0	5.8	6.6	7.7	8.3	9.4	11	9.7	13	
6	1.25	2.1	2.3	2.7	5.3	6.0	7.0	7.6	8.6	10	8.8	12	
7	1	3.8	4.3	5.0	9.7	11	13	14	16	19	16	22	
8	1	5.9	6.6	7.8	15	17	20	22	24	29	25	34	
8	1.25	5.5	6.2	7.3	14	16	19	20	23	27	24	31	
10	1.25	11	13	15	29	33	39	42	48	56	49	66	
10	1.5	11	12	14	28	32	37	40	45	53	47	62	
12	1.25	21	23	28	53	60	71	76	86	101	89	119	
12	1.5	20	22	26	51	58	68	73	82	97	85	113	
12	1.75	19	21	25	49	55	65	70	79	93	81	108	
14	1.25	26	29	34	66	75	89	95	108	127	111	148	
14	1.5	28	32	37	72	82	96	103	117	138	121	161	
14	2	30	34	40	78	88	104	111	126	148	130	173	
16	1.5	50	57	67	129	146	171	184	208	245	215	287	
16	2	47	53	62	121	137	161	173	196	230	202	269	
18	1.5	73	82	97	187	212	249	268	303	357	313	417	
18	2.5	65	73	86	167	189	222	239	270	318	279	372	
20	1.5	101	115	135	270	306	360	374	424	498	437	583	
20	2.5	91	104	122	236	267	314	337	382	449	394	525	

Clamp load calculated as 75% of the proof load for specified bolts. K = 0.15 for "lubricated" conditions
 All torque values are listed in foot-pounds K = 0.17 for zinc plated, dry conditions
 Torque values calculated from formula T=KDF, where K = 0.20 for plain and dry conditions D = Nominal Diameter
 F = Clamp Load

©

T

MAINTENANCE

LUBRICATION RECOMMENDATIONS

MAINTENANCE

Description	Application	General Specification	Recommended Mobil Lubricant
Viædq P^ â!æ æ•Á	Ü^•^!ç[ä	RÖËEO T ØÄ FFHÍ Ê FFI F ØPT GÓFHI ÖÇØPGEFD	T[àãq̄ ãÁ G
T[, ^!P^ â!æ æ• Ö[ãÁ^ { } ^!æ ^•Æ ÜæðM	Ü^•^!ç[ä	ØUÁÍ ÁÇ æY ^æË , Á^ { }	T[àãÖVÒFI T
P[{ æÁ^ { } ^!æ ^• F»ÁÜæðM	Ü^•^!ç[ä	RÖËEO T ØÄ FFHÍ Ê FFI F ØPÁT GÓFHI ÖÇØPGEFD	T[àãq̄ ãÁ G Á
P[{ æÁ^ { } ^!æ ^•Á FÍ »ÁÜæðM	Ü^•^!ç[ä	ØUÁÍ ÁÇ æY ^æ	T[àãÖVÒÁG
Pã ÖU] ^!æã * Á^ { } É Öä[ç^ÁÉ»Ø	Ü^•^!ç[ä	ØUÁÍ ÁÇ æY ^æ	T[àãÖVÒFI T
ØæÁÜæÖ^æà[ç Ü^•^!ç[ä	Ü^•^!ç[ä	ÜÖUÁÜ^ } @æÁÖçd^ { ^ Ü!^•• ^!ÁÖ^æS^ à^	T[àãÁUPÓÁÍ Y ÈÉ T[àãÁÜ^ } @æÁÖ^æ
Ö^ æ^!ÁÜæBÁÖ[~ } á Ü[^!ÁÜæçQæD Ö^ }	Ö!^æ^ Ö^ }	ŠæÇ { ÈÖ[{ } ^ç Öçd^ { ^ÁÜ!^•• ^! PŠÖÖUÁGÉ	T[àã*!^æ^ÁÖT ÈÜ
Ö!æÁÜæÖ[~ } ^! QæÁæ áÁÜ[æ^ D	Ö!^æ^ Ö^ }	ŠæÇ { ÈÖ[{ } ^ç Öçd^ { ^ÁÜ!^•• ^! PŠÖÖUÁGÉ	T[àã*!^æ^ÁÖT ÈÜ
Ö!æÁÜæÄ[\^É WÈ q çBÁÜc àÁÜæc	Ö!^æ^ Ö^ }	ŠæÇ { ÈÖ[{ } ^ç Öçd^ { ^ÁÜ!^•• ^! PŠÖÖUÁGÉ	T[àã*!^æ^ÁÖT ÈÜ
Ö[{ { ÁÜ, æ^ Ö[{ { ÁÖ^ q á^!ÁÜæç Q[] æ^ ÁBÁQæÁÖ[{ D	Ö!^æ^Á Ö^ }	ŠæÇ { ÁÖ[{ } ^ç Öçd^ { ^ÁÜ!^•• ^! PŠÖÖUÁGÉÁ	T[àã*!^æ^ÁÖT ÈÜ
Ö^ & ÁÖ[{ { ÁÜæ[çB Ö^ & ÁÜç] ÁÖæb • ç ^ } c Ü[] æ^ ÁBÁQæD	Ö!^æ^ Ö^ }	ŠæÇ { ÁÖ[{ } ^ç Öçd^ { ^ÁÜ!^•• ^! PŠÖÖUÁGÉÁ	T[àã*!^æ^ÁÖT ÈÜ
Ö^ & ÁÜ] q á^Q[] æ^ D	Ö!^æ^ Ö^ }	Vá ^!ÁÜ] q á^ÁS^ à!æç c] æç { à^!ÁÉ ÉÉÉÉ	T[àãÖUÁPÓÁGÉ

Ö[{ T æç } æ & ÁÜ^æç } Á È

MAINTENANCE

POLYCARBONATE CARE AND MAINTENANCE

V @ Á] [] | a d ^ Á V X Á q á Á C á i a e q } Á Ú ¨ ¨ á c q á Ú ¨ | a e Á & q a q * Á [} Á Ú P C S Ö Ü Á Ú W Ú Ö Ü Ö U C E / Ö Ö Á [| r & e á [} a e ¨ ¨ • a } a e q d ^ Á q] | [ç ^ Á ¨ ^ | { } q & E Ú Á q á a e Á ¨ q q * Á • q * Á [] ^ Á [| & ¨ ¨ ^ Á q á Á q { } a e ¨ ¨ Á q ¨ ¨ ^ Á • Á ¨ ¨ Á ¨ & { { ^ } á ¨ ¨ Á q] | [] * Á ¨ ¨ ç Á Á Á Á / á ¨ ¨ Á Ö [] É [| r & e á [} a e ¨ ¨ Á Ú W Ú Ö Ü Ö U C E / Ö Ö Á } Á [c q á ¨ ¨ ^ E

Ö S Ö C E P Ö Á P Ö Á Ú W Ú Ö Ü Ö U C E / P Ö Ü Ö E Ö U C E /

F È Y a e q á a e Á q á Á [| r q } Á Á [q Á | Á ¨ ¨ ^ Á * ^ } q q á ¨ ¨ ^ Á , q { Á a e Á È

G È W q * Á q [- & [c q | Á] [] * Á E ^ Á) d ^ Á a e q á Á c q Á @ ^ Á q Á [. ^ } Á á a e Á q á Á q ^ Á q á Á q • Á ^ | | Á q á ¨ ¨ ^ Á q á Á , a e Á È

H È V | Á | ^ ç ^ } c q a e Á [c q * Á q | ^ * q Á | ^ Á q á a e Á q [q Á | Á ¨ ¨ ^ Á | | . ^ Á [] } * Á È

I È C q [q á Á c q Á • Á q a e Á q á Á ¨ ¨ ^ Á q á Á • Á ¨ ¨ ^ Á * Á ¨ ¨ ^ Á • Á q á q d | Á c q | Á ¨ ¨ ^ Á q q * Á q] | { ^ } c Á c q a e Á q á q á Á Á [^ * Á ¨ ¨ Á c q a e Á * È

Ö S Ö C E P Ö Á C E Ö P V U Á P C P Á P C X Ö Á Ö Ö Ö P Á Ö U W P Ö Á V U Á Ö Ö Á Ö U T Ú C E / Ö S Ö Á W P Ö Ö Ü Á S C Ö U Ü C E U Ü Y Ö U P Ö Q W P Ü K

C E ^ Á [^ • Á Ú [| r q } • Á Á Ú [q } • Á q á Á ¨ ¨ ^ Á * ^ } c

Y q á ¨ ¨ ^ ç F D	V [] Á q á c E D	R ^ c E D	T Á Ö a e q c E D
Q q a e q ç F D	Q { ^ a e Á e J ç D	Ü { q q á @ Á Ö F G	Ó ^ & q á ¨ ¨ & a e
U * q á Á Ú [ç ^ } c			
Ö ¨ ¨ c Á Ö [ç ^	S ^ [. ^ } ^	P ^ ç É Ö Ü É	P q á @ c q X T B U Á a e Á D
P ^ ^ & É Ü a e Á	V ^ & Á e G		
C q q			
T ^ c q q [Q [] [] ^		

C q Á ¨ ¨ ¨ q á | * q á Á [ç ^ } c Á q | á ¨ ¨ ^ Á ¨ ¨ ^ { [ç ^ á Á q á a e Á ¨ ¨ ^ & q } } á a e Á q • Á È

GRAFFITI REMOVAL

Ö ¨ ¨ c | Á ¨ ¨ | | [| ç ^ Á ç | Á ¨ ¨ { [ç q á Á q a e Á q • É q a e Á q * Á ^ } Á | • É q • a e Á É Á Á É V @ Á • Á Á q a e Á q * Á q a e Á ¨ ¨ ¨ ^ Á q á ¨ ¨ ^ Á q a e Á ¨ ¨ | | Á q á ¨ ¨ { [ç q á Á [| • Á [| | Á ¨ ¨ | | Á q á q * Á Á | á Á ^ a e Á | á Á q a e Á q • È

V | Á ¨ ¨ { [ç ^ Á a e Á ¨ ¨ • É q a e Á ¨ ¨ | • É q a e Á q @ Á • Á Á ¨ ¨ | [. ^ } ^ Á | Á X T B U Á q á @ c q á Á ^ } a e Á q a e Á ¨ ¨ ^ Á q a e Á q a e Á | ç ^ } c , q | Á [c q ^ } ^ d a e Á a e Á ¨ ¨ | Á a e Á q a e Á] | Á c q a e Á ¨ ¨ | ^ Á D Á [- e } Á c q a e Á q a e Á q á Á [{ [ç ^ Á ¨ ¨ { [ç q á È

Q U U Ü V C E P V Á C q á a e Á q á Á • Á q ^ } á Á q Á ¨ ¨ & q [] a e ¨ ¨ Á q Á q á Á c q | c q | Á c • c q á q | Á • q a e Á ¨ ¨ ^ Á q ^ } á Á q Á ¨ ¨ q & [] a e ¨ ¨ Á q Á c q | á É V @ Á q] ç ^ | • Á É q ^ ç ^ | É q Á [c q q a e Á ^ Á ¨ ¨ ^ Á q a e Á ¨ ¨ | | Á q a e Á ¨ ¨ | Á q a e Á ¨ ¨ | c c q a e Á c q á } á È ^ Á q } á a e Á } • Á c q a e Á ¨ ¨ | Á q | a e ¨ ¨ á É V @ | ^ | | Á ¨ ¨ c q a e Á ¨ ¨ | • Á q a e Á | á ¨ ¨ ^ Á • Á a e Á q a e Á q a e Á ¨ ¨ | ^ q a e Á ¨ ¨ ^ & q { { ^ } á ¨ ¨ Á c q a e Á c q a e Á • Á c q a e Á | | á & ö Á } á ¨ ¨ Á c q a e Á } á È • Á & [] á a e Á } • É

Ö [{ T q q c } q & Á ¨ ¨ ^ c q } Á È €

MAINTENANCE

MAINTENANCE

MAINTENANCE

GREASING GROUND ROLLER SHAFT-- FLAIL

Š[&æ^Á^i^æ^Á^i\•Á} Áæ& Á} áÁ Á[||^i^Á^ à^Áæ
 ||, ^i^Á} áÁ Á@æ& [i{ æ& } ááá} •Á^~ á^Á} ^Á^i
 ç [Á^~ { } •Á^æ&@Á^æ& * Á^ •á * Á^æ& { É[{ }]^ç
 Öçd^ { ^Á^i^æ^Á^i\•Á} i{ } á * Á^ Á^ SÖÖÉU
 HGEÁ^] ^ááæ& } •ÉV@Á^áÁç Á^Á^ [] ^Á, á@æ
 •æ} áááÁ^i^æ^Á^~ } Ááá Á^i^æ^Á^i\•Á^ 8 hour intervals.
CAUTION: Over greasing may cause premature seal failure



ADJUSTING/CHECKING BELT TENSION

V[Ááá •óÁ^i^ç^} •á } Á^i^Á^ |æ& Á^i^ç^} Á^áá& æ^i
 @æ& É^ [ç^Á^~ i^Á^ |ç^ç^Á^& i^Á^ç^ç^i^ç^ ç^i
 æ} áÁ^ [ç^Á^ ç^i^ÉV@Á^ç^Á^ ç^Á^ç^ } Á^i^ [, Áæ&
 à^Ááá •ç^áÁç Á^ & i^æ^É^& i^æ^Á^ç^ç^Á^i^ç^} •á }
 æÁ^ Á^á^áÉçUVÓÁ^Š[&æ& } Á^ Ááá •ç^ } ç^i^ç^
 { æ^Á^ç^ } Á^áá& æ^i^Á^ç^ç^ •É Be sure to replace
 the belt cover BEFORE operating mower!

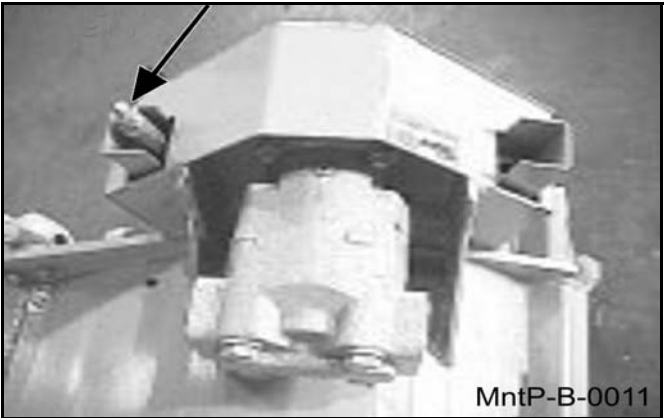

TIGHTENING KNIFE BOLTS AND DISK BOLTS:

Öç^i^Á^ç^i^ Á^ç^i^ •Á^ Á^]^i^æ& } Á^i^Ááá Éç^Á^} á^
 Ó[|ç^ç^ ááá^ Á^ |ç^Á^ç^ i^á^Á^á^ ç^} ^á^æ^ Á^ || , •K
 S) áÁ^ [] ç^ * Á^ |ç^ç^i^~ ^Á^ Á^ Éç^i^ á^áá^á^á^ •É
 Öç^ Á^ [] ç^ * Á^ |ç^ç^ç^i^~ ^Á^ Á^ç^i^ Á^i^ Á^i^ É
 |^ á^áá^á^á^ •É



Ó[{ T æ ç } æ & Á^i^ç^ } Á^ ÉH

MAINTENANCE

MAINTENANCE

GREASING POINTS ON BOOM AND PIVOT

Identify the greasing points on the boom and pivot. The image shows a close-up of the boom and pivot area with arrows pointing to the greasing points.

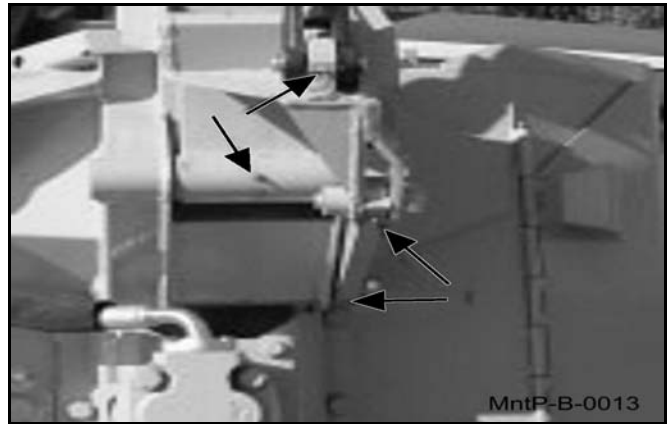

DECK STOP ADJUSTMENT

Adjust the deck stop. The image shows the deck stop adjustment mechanism with arrows pointing to the adjustment points. **NOTE: Bolt should not hit boom before cylinder reaches full travel.**

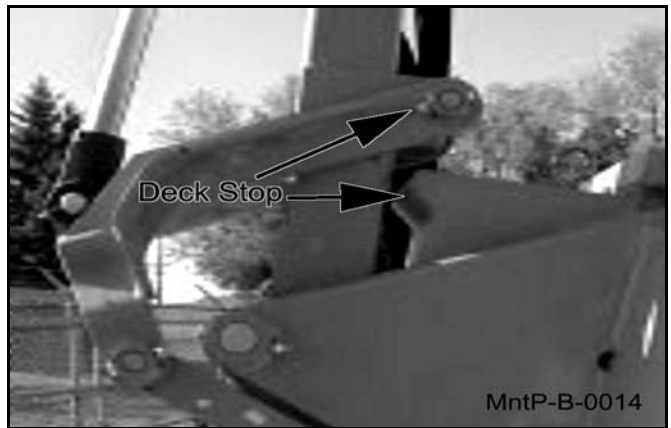

GREASING SPINDLE

Identify the greasing point on the spindle. The image shows a close-up of the spindle with an arrow pointing to the greasing point.



©

T

MAINTENANCE

MAINTENANCE

TIGHTENING SPINDLE BOLTS

Verify that the spindle bolts are tightened to the correct torque. The spindle bolts are located on the rear of the spindle housing. The correct torque is 100 ft-lb (136 Nm).

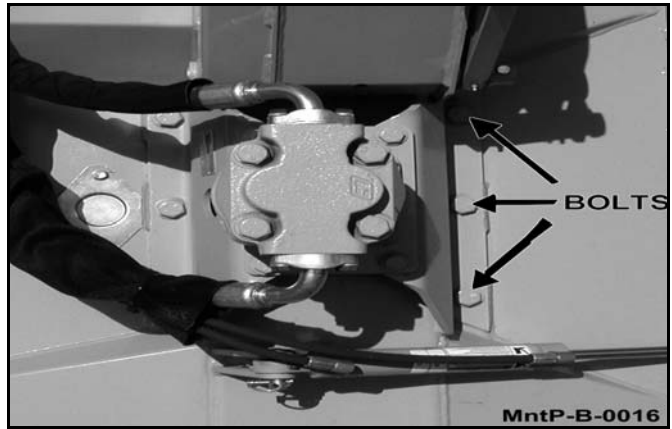

GREASING PUMP DRIVE SHAFT COUPLER

Apply grease to the pump drive shaft coupler. The coupler is located on the front of the pump housing. The correct amount of grease is 1/2 cup (118 ml).



MAINTENANCE

MAINTENANCE

DRIVESHAFT YOKE, U-JOINT STUB SHAFT

Y @A ^)* q ^A .d]] ^aEa q b&A Sãca { EÖ[{]|^c
 ^cd^ { ^A|^••|^A|^æ^A&[]-|{ q *Aq ApSÖÖÖU
 HGEA]^8ãããã}•Aq d^A} q^i•æA q oAq aA|q A[\ ^
 ~} qA|^æ^Aq]^æ•AaA@A^æEÖ|^æ^A@{ Aããã
 [|Aç|^i^A@~|^E

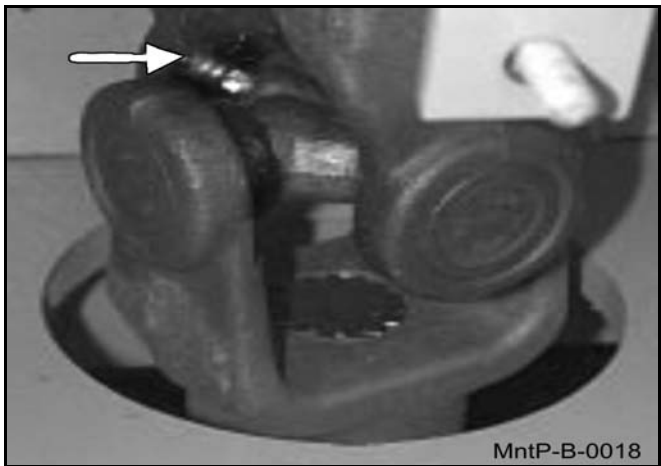

MntP-B-0018

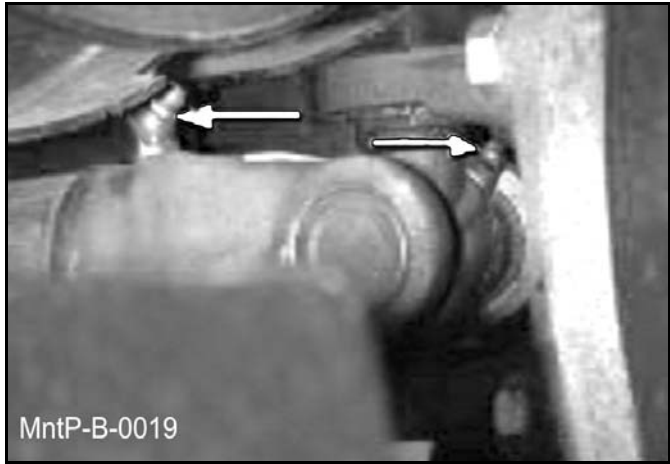

MntP-B-0019

GREASING THE BOOM SWIVEL

Š| &æ^A@A: ^|\•A[} Ac@A{ æA• q^|Aa[••AÇ
 æ]}|ããã^D^A| æA|[{ } A] q[aA[••AÇãã]}|ããã^D
 æ}ãA[] Aa[c@^}ã•A[-A@^Aa[{ } A• q^|Aç| q a^iE
 Qb&AŠãca { EÖ[{]|^cAÖcd^ { ^AÚ|^••|^A*|^æ^
 &[]-|{ q *Aq ApSÖÖÖUÁHGEA]^8ãããã} A^} q
 |^æ^A^ q •Aq A| | d^ã^A[{ } A]ã•E

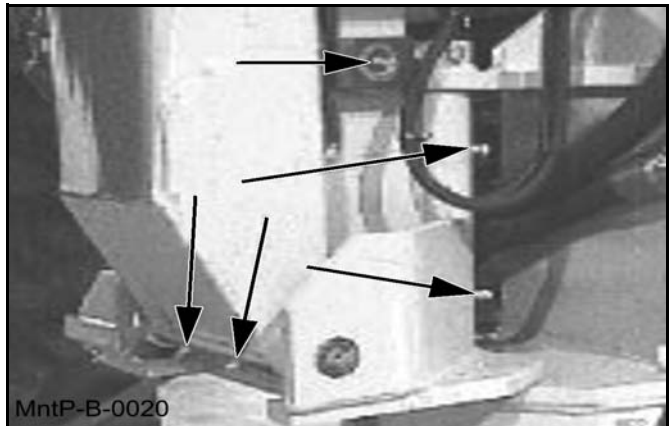

MntP-B-0020

Ö[{

T æ ç} æ &^A^&ç} A Eİ

MAINTENANCE

MAINTENANCE

GREASING BOOM CYLINDER(S) PIVOT POINTS

Š[&æ^Á@Á^!\Á} Á@Á^ wÁ) áÁæ * Á -Á& |á á^!Áæ á
[] Á[áÁ} áÁæ * ÉQp&ÁŠæ { ÉÖ[{]|^ÁOæd^ ^
Ú!^••!^Á^!^æ^Á& } f!| á * Ád ÁpSÖÖÉUÁHGE
•]^&ááææ } •Á} dÁ^!^æ^Á^* á •Áf Á!| d^ á^Á!{
^} á •ÉV@Á!| &^á^!^Á^Á Á^Á^ •^áÁ} Á@Á! æ
à[[{ Á& |á á^!ÉÁ^•& } áæ^ Áà[[{ Á& |á á^!ÉÁ^•&
] æ[dÁæ áÁ •, æ^!Á& |á á^! •Ááæ Á! ÁæÁ Á@^!
á c!çæ É

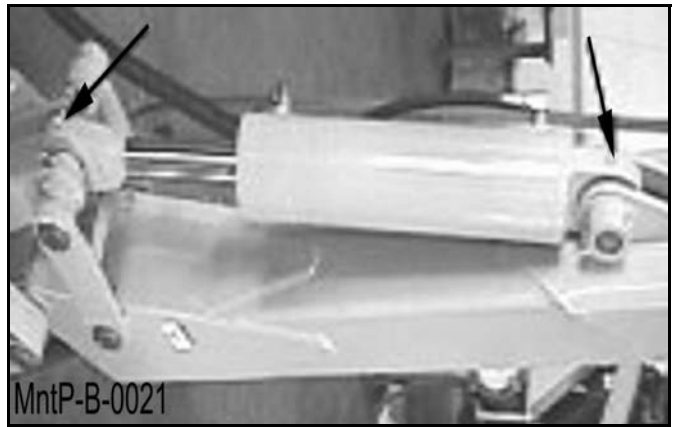

BALL VALVES

V@Áæ|Áçç^ÁæÁ@Á@á!æ |áÁ^•^!ç| áÁ æÁ^á
d Á^Á&| •^áÁ^ |á * Á&|æ Á æ c} æ &Á!Á^] æ
]!| &^á^! •É **THE BALL VALVES MUST BE OPEN**
(handle parallel with valve) WHEN TRACTOR IS
RE-STARTED OR PUMP IS COUPLED TO
MOTOR OR PTO!ÁOæ^!^Ád Áá[Á [Á] Á!^• |ç
&{ } [] ^} Áæ^!^Á

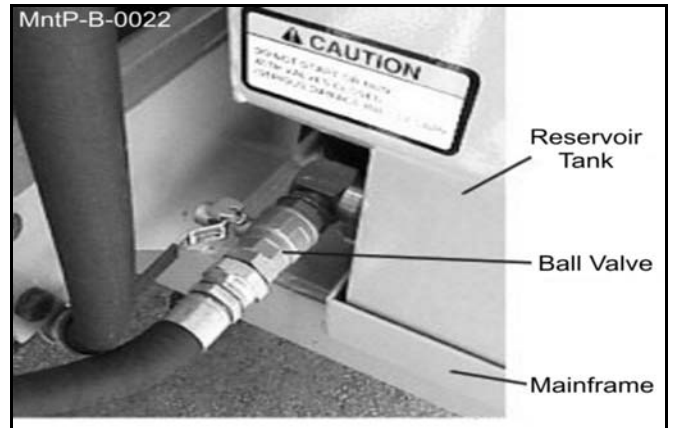

Ö[[{

T æ c} æ &Á^&ç } Á Èí

MAINTENANCE

MAINTENANCE

ROTARY KNIFE REPLACEMENT

- FÈ ÓÁ~!^Á[~Á@e^Áe {]|^cÁ æ&@ *Á^cÁ-Á^, Á} ã^•Á|Á^|æ^ { ^} È
- GÈ Ü^ { [ç^Á} ã^•Áe áÁ•] ^&ÁQ|^•Á|Áæ æ^ÉQ[Á æ&@|Á&æ •Á@Áá \Áá] |æe|Áe [~ } áÁ @ÁQ|^•É
- HÈ Š^ á^Á@^æ•Á æÁe cē^á^ÉQ•æ|Á[|oÁ@|^* @] ã^Áe áÁá \Á| { Á[c { Áæ^Á-Áá \É|æ^ÁæÉ Q•æ|Á^, Á^|É| & ã^*Á^•Áe áÁ|!~^Á@{ Á|Á€Áá•É
- IÈ V@Á} ã^•Á@|^!á, ã^*Á^!|Á|Áæ•[!á@&•Á|{ Á]æ&@ } Ácãã*Ááb&•É

WARNING WHEN CUTTING HEAVY BRUSH, KNIFE BOLTS SHOULD BE INSPECTED HOURLY AND RETORQUED TO 800 LUBRICATED FT. LBS.

REPLACEMENT OF ROTARY DISK/BLADE BAR

CAUTION Failure to follow the following warnings and instructions may result in serious injury or damage to the equipment or property!

- FÈ V@Á| |oÁ@eæ&@Áá \Á|Á@Á|ã^á^Á~•cÁ^!æ^ÁÉV@•^ÁÉ&@ [|oÁe^Á|Á^!~^áÁ GÉ Á|Á|Á|Á|Áá•Á|á|æe^áÁ æ&@ & Á FÈ
- GÈ Qe@^æ|Á| & ã^*Áe^} cÁ æ^Á^Á| |ã^Á|Á@^æ•Á-Á|Á [~ } cÁ^Á| |oÁ^!|Á@^Áe^Á•æ|áE
- HÈ **Disks must be inspected daily for hairline cracks between spindle mounting bolts or around the knife mounting bolts. These cracks indicate metal fatigue caused by severe abuse. If cracks are present the disk must be replaced.**
- IÈ Q•|^&Ác@Ááá \Á| [~ } cÁ^Á| |oÁæ^Á @} Á&@& ã^*Ác@^•Á|Á} ã^Á| [~ } cÁ^Á| |oÉQeÁáá \ { [~ } cÁ^Á| |oÁ| |•^ÉÁ~•cÁ^Á^ { [ç^áÉc@æ•Á|e^áÉ^•Á@^æ|Á| & ã^*Áe^} Áe| |ã^áá á c@^}^áÁ|!|Á|!~^Áe^ÁE
- ÍÈ QÁ} ã^Á [~ } cÁ^Á| |oÁ| |•^É@Á^|Á| & ã^*Á^cÁ~cÁ^Á| |æ^áÁeÁæ^cÁ|^&e cÁ} ÉŠ^ á|æe c@^æ•Á æÁe cē^á^ÉQ•æ|Á[|oÁ@|^* @] ã^Áe áÁá \É|æ^ÁæÁ| { Á[c { Áæ^ÁQ•æ|Á^| | & ã^*Á^•Áe áÁ|!~^Á@{ Á|Á€Áá•É

MAINTENANCE

Blade Pins and D-Ring Inspection

Q.] ^ & o | a a ^ A U a . A e a A O E U a * . A a a A r | A ^ a e A | A a e a e ^ A e A r | | , . A A

⚠ DANGER

Q.] ^ & o | a a ^ A U a . A e a A O E U a * . A a a A r | A a a } [| { a A ^ a e A a e ^ A ~ | ^ A @ A e a | A a . A e a a A | a e A a A | [] ^ | r A | ^ a a E U O U S O O O A S O O O A U a . A e a A O E U a * . A T O O O E V O S Y A A @ ^ a K

- ~ X a a | ^ A e a . A !
- ~ Q a A U a A | A O E U a * A e a A a a | A [] | A e a e E !
- ~ Q a A U a A | A O E U a * A e a A [~ ^ . A | A & a] ^ a A e a e

O a a | ^ A e A | a e A a a } [| { a | A [] | A a . A | A O E U a * . A a e A a a A A e a e d [] @ A a a | ^ A e a a A b & a } A A @ A | [\ ^] a e A e a e A e e . ^ A A a ~ . A [a a A b i r A | A a e E

O e a e A ^ | a e A a @ A a . A e a A O E U a * . A @ } ^ a | A e & . . a ^ A ^ a e A [a e a e A

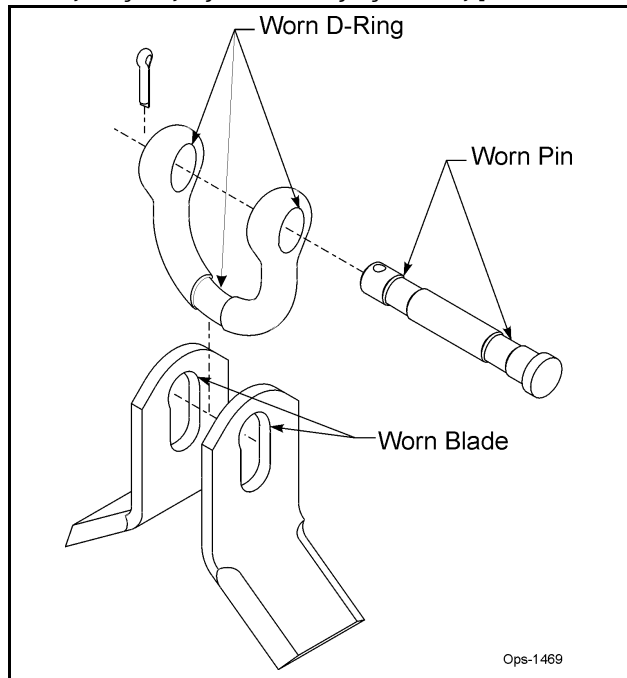

Important

Q a o A e a | A a . A e a A | [\ ^] A a A e } a e a a e a e a | a a a a a . E a [[a ^ A @ A a A e a a A a ^ . A @ A a a & a } A @ A a A e a . A | a a @ [~ ^ . A a A O E U a * A [A e a o A e a | A a . A e a A | [] | . a . a A A a @ A O E U a * E V a A a | A ^ a ^ . A @ A a e o A o A | a a . A | [A , a * a * A a e A a a A @ a * @ A e a | A a e E PS-U-0045

MAINTENANCE

Q [[T a e e } a e A A & a } A e E

MAINTENANCE

Flail Axe Blade Bolt Inspection

Q•] ^&ó|æ^ÁÓ| |óææ Áí !Á ^æÁ!Áææ æ ^Áæ Áí ||, •K



Q•] ^&ó|æ^ÁÓ| |óææ Áí !Áææ} [!{ æÁ ^æÉÚÓÚŚÓÓÒÁĖŚŚÁÓŚ ÓÒÒÁÓÚ ŚVÚÁ } Áó@ &æ!á!Á T ÓÓÓĖ/ÓŚYÁÁæ } Áí |ó Áóæ^K

- ~ Xā ā| ^Áææ. Á!
- ~ Qó@ Áíææ^Áí |ó Á [!] Á! Áæ ^ Á&••^áÁæ^ææ Áæ ā| Áí } Áó@ Áí |Ė!
- ~ QÓ|ææ^ÁÓ| |óææ Áí ^*^ Á! Áí } ^áÁæ^æ Ė!
- ~ QÓ• @* Áā Áí [•^ Áí ÁóÁÚ] Ė! ÁÚæĖ

Qææ !^ÁĖ Á^ |æ^Áó|æ^ÁÓ| [!{ æÁ Á [!] Áá |ó Áí !Áæ^ • @* • Áí æ Á^ææÁĖ Á&ææ d [] @Áææ !^Áí Áó@ Áíææ^ Áæ ā ^Ė&Ė } Áí Áó@ Áí [\^] Áí æĖĖ @Ė@Ė æ Áæ^ Áí āí • Áí [āā Ė b! ^ Áí !ÁææĖĖ

QĖ, æ Á^ |æ^Áó|æ^ÁÓ| |ó Áí æĖĖ, Áí |ó Áí āÁ^, Áí • @* • Áí @ } ^Ė^! Á^ |ææ * Áó@ Áíææ^ ĖM Áæ @ } Áí |ó æ āÁ ~ ĖĖá • óĖ } | Áó@ææÁí & Áí Áí ĖĖ æ Á^ !^Áí Áí @ } Áí |ó Áí āÁ ~ ĖĖ • óĖ } [~ @Áí Áí [, Áó@ Áíææ^ Áí •, ā * Áí^! Áí āÁ [óĖ^] āÁóÁ& Ė! • @óĖ * ĖĖÁ& Ė! • @óĖ * Áæ^ Áí^ } óĖ ^* @ | Áí^ &æ^ Áí ĖĖ^! Áí @ } ā * @ Áíææ^ Áí āÁ [óĖ, ā * Áí^! ĖĖĖOPS-U-0043

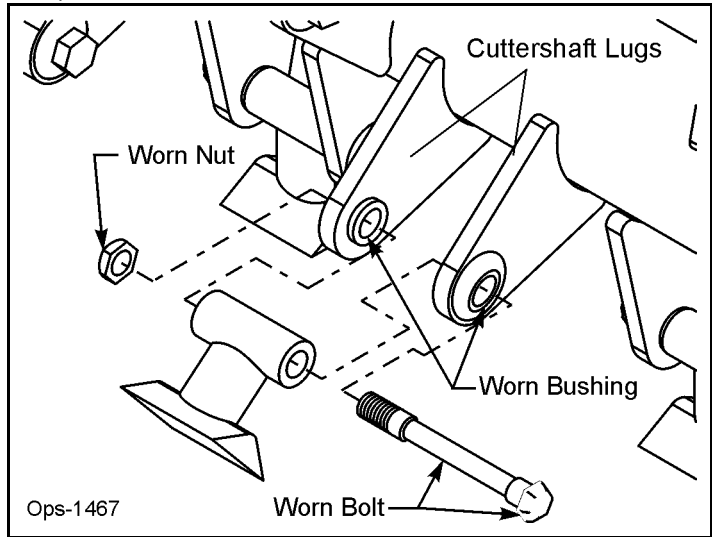

MAINTENANCE

Ó [{

T æĖ } æ & ÁÚ^ &Ė } Á ĖĖ

MAINTENANCE

THE SPINDLE ASSEMBLY

Ú^Á@Áæ!æÁ^[[, Á!Á^ cææ}Á-Á]áá^ÁæóÉ @Á^!çæá*É

MAINTENANCE

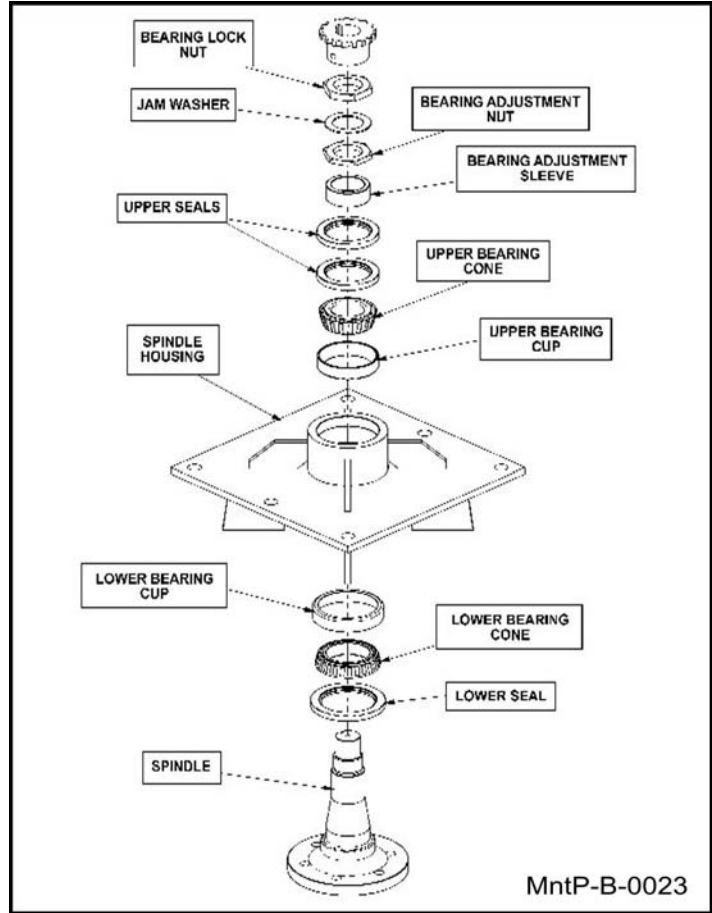

Ó[[{

Tæç}æ&Á^&ç}ÁÉ

MAINTENANCE

MAINTENANCE

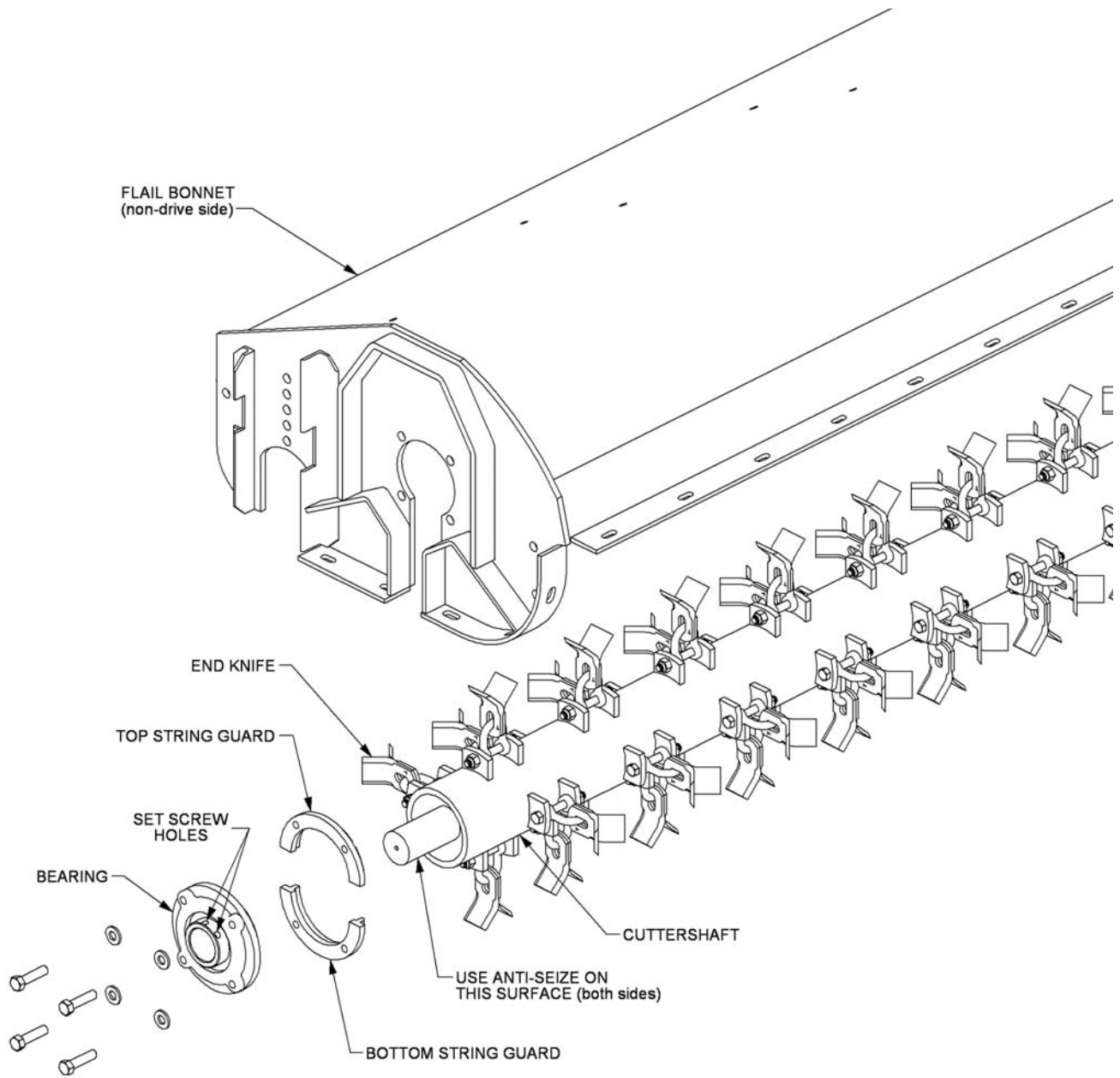

MAINTENANCE

MAINTENANCE

DAILY MAINTENANCE SCHEDULE

V@Á-| | | , q * Á·^içæ·Á·@~|áÁ^Á] ^iç|{ ^áÁáæ~ Á! Á^ç!^ Ái Á@~!·Á[-Á·^içæÁ-É-| | | , q * Áç@Á^æ^á { æç } æ & Á·d~ &ç } ·Á·Á@Á] ^iç|!qÁ æ~ æÉ

~~~~~ ÁÚ~ { ] Á!á·@æçÁ~ á^áÁ æç!á·@æç~ ] |^iç@& Á! Á} áÁ|æ Áæ áÁ à!ææÁ·Á·É

~~~~~ ÁÖ!æ\·@æçáæç ç!KÁ~ q ] ^áÁ æç~ áà!Á! [ { { ^ç@& Á! } áæ } É^ ] |æ^Áá á·q \* Á! ÁÁÁ áæ æ^áÉ

~~~~~ ÁÚç [ ç ] q ·KQ·&ç!^æ^Á} çÁá ] ^æ·Á·Á} á·É

~~~~~ ÁP^á!æ |æÁ·æç \* ÁÖ@& Á! Á!^æ·Á, æç] æç!Á! Á&æáà| æáÉVá @^ Á·æç \* Á! Á!^ ] |æ^Á@·^· q { ^áæ } É

~~~~~ ÁS} ç·KQ· ] ^çç! Á á·q \* Á! Áæ æ^áÁ} ç·É&ç \* ^ç } |^ç! Á^ç Á^á^áÉ

~~~~~ ÁÖ!ç KÖ@& ç @^ É^ ] |æ^Á!ç Á·Á^á^áÉ

~~~~~ ÁT æç çæ ^É& ÁV |··Á ç@! , á^Á] ^æááÁ^ç!~ ^Á [ ç Á&ç! áá \* Á! Á! ^~^Á] ^æææ } ·Á·@ ·^ç } É

~~~~~ ÁP^á!æ |æÁ· æÁç!KÖáÉÁ~ á^áÉ ^iç| æÁ& { { ^ } áæ } ·É

~~~~~ ÁÚ^æÁçÁ! ç·É^æç \* Á!æ \* ^Áæ áÁ @æç~ ] |^iç!^æ^Á·Á·d~ &çáÁ Á@Á^æ^áÁ æç } æ & ·^ç } É

~~~~~ ÁÖ ç!·@æç áÁ! [ ~ } áÁ [ |^iç!^æ^Á·Á·d~ &çáÁ Á@Á^æ^áÁ æç } æ & Á^ç } É

Ú^içæÁ ^iç|! { ^áÁ·K ~~~~~ ÁÖæ·K ~~~ É ~~~ É ~~~ ÁP [~!

T^ç!K ~~~~~

T æç } æ & Á·&ç }

ÉV@Á æ^Á æÁ^Á] áááæ áÁ·^áÁ çç! Á·@Áæç Á æç } æ & Á! ~ ç^É

Ö [{ T æç } æ & Á·&ç } Á É F

MAINTENANCE

MAINTENANCE

Ó[[{

T a} a & ^ Á & a } Á Ë G

'B< 'HG* 'L'L'H(6 '&K 8 'BENGAL

D5 F HG' G9 7 H=C B

PART NAME INDEX

| | |
|---|----|
| PARTS ORDERING GUIDE..... | 3 |
| TRACTOR MOUNT KIT..... | 4 |
| TRACTOR MOUNT KIT - HYDRAULICS..... | 6 |
| ELECTRONIC PROPORTIONAL LIFT VALVE MOUNT..... | 8 |
| JOYSTICK AND SWITCHBOX MOUNT..... | 10 |
| BATTERY RELOCATION..... | 12 |
| POLYCARBONATE..... | 14 |
| WHEEL WEIGHT..... | 16 |

PARTS ORDERING GUIDE

The following instructions are offered to help eliminate needless delay and error in processing purchase orders for the equipment in this manual.

1. The Parts Section is prepared in logical sequence and grouping of parts that belong to the basic machine featured in this manual. Part Numbers and Descriptions are given to help locate the parts and quantities required.
2. The Purchase Order must indicate the **Name and Address** of the person or organization ordering the parts, **who should be charged**, and if possible, the **serial number of the machine** for which the parts are being ordered.
3. The purchase order must clearly list the **quantity of each part**, the complete and correct **part number**, and the basic **name of the part**.
4. The manufacturer reserves the right to substitute parts where applicable.
5. Some parts may be unlisted items which are special production items not normally stocked and are subject to special handling. Request a quotation for such parts before sending a purchase order.
6. The manufacturer reserves the right to change prices without prior notice.

NOTE: When ordering replacement decals, refer to the part numbers and descriptions listed in the safety section in the front of this manual.

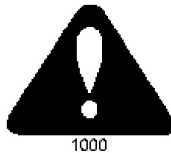

For maximum safety and to guarantee optimum product reliability, always use genuine **Tiger** replacement parts. The use of inferior replacement parts may cause premature or catastrophic failure which could result in serious injury or death.

Direct any questions regarding parts to:

Tiger Corporation
3301 N. Louise Ave.
Sioux Falls, SD 57107
1-800-843-6849
1-605-336-7900

TRACTOR MOUNT KIT

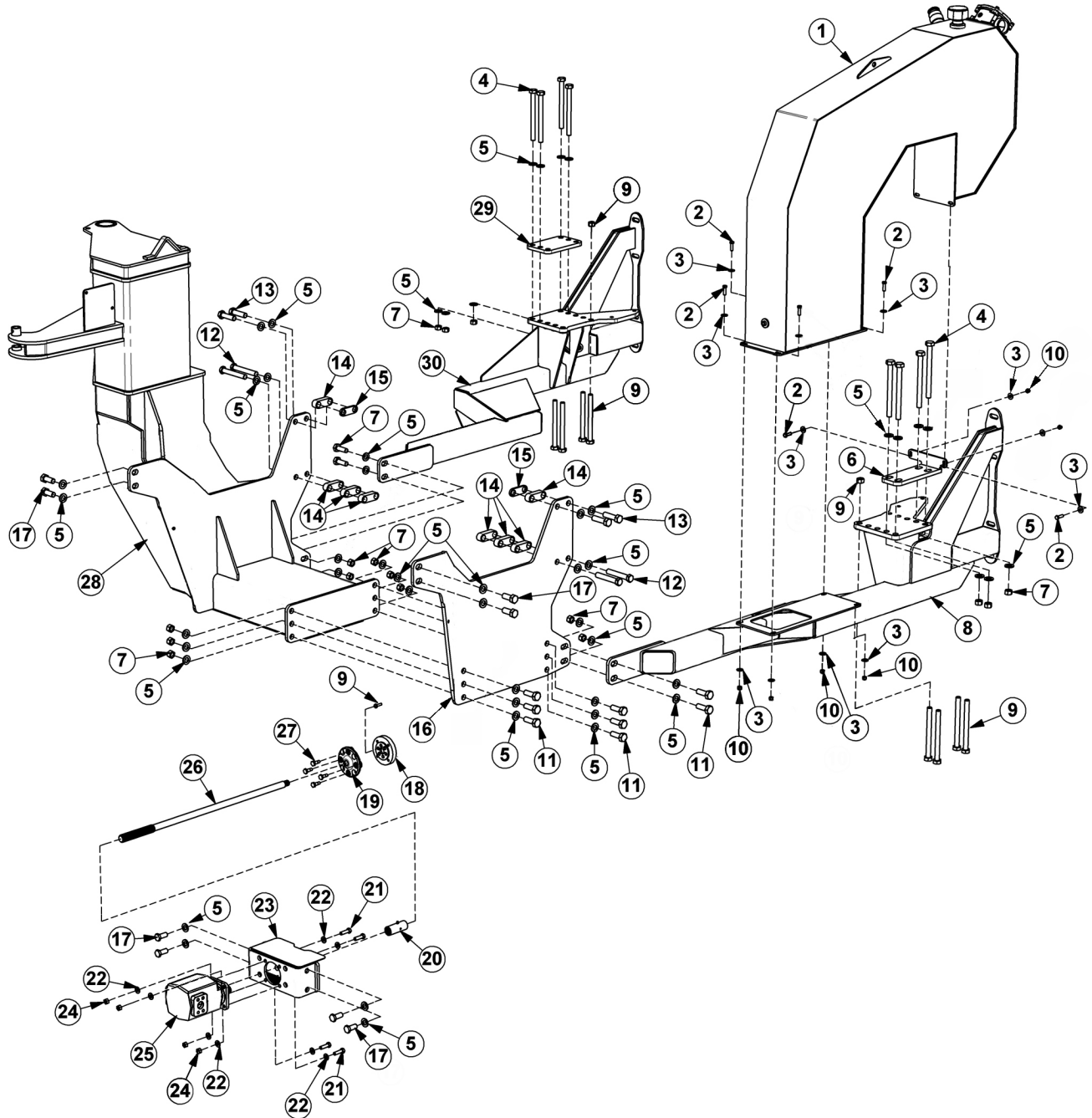

TRACTOR MOUNT KIT

Continued...

| ITEM | PART NO. | QTY. | DESCRIPTION |
|------|----------|------|--------------------------------|
| 1 | 06700215 | 1 | TANK,RES,ASSY |
| 2 | 21631 | 8 | CAPSCREW,3/8" X 1-1/4", NC |
| 3 | 22016 | 16 | FLATWASHER,3/8 |
| 4 | 21846 | 8 | CAPSCREW,3/4" X 9", NC |
| 5 | 33880 | 46 | FLATWASHER,3/4" |
| 6 | 06380082 | 1 | TANK MNT ASSY |
| 7 | 21825 | 18 | HEX NUT,3/4", NC |
| 8 | 06300280 | 1 | AXL BRC,LH,TS6.1XX,T4B,RS |
| 9 | ----- | - | *EXISTING JD HARDWARE* |
| 10 | 21627 | 8 | NYLOCK NUT,3/8", NC |
| 11 | 21833 | 10 | CAPSCREW,3/4" X 2-1/4" NC |
| 12 | 06530537 | 4 | CAPSCREW,20MMX120MM2.5P,GR10.9 |
| 13 | 32285 | 4 | CAPSCREW,20MMX75MM(2.5)GR10.9 |
| 14 | 06401627 | 8 | SPACER,1" |
| 15 | 06401630 | 2 | SPACER,5/16" |
| 16 | 06412357 | 1 | UPRIGHT,LH,TS6.110,T4B |
| 17 | 31731 | 8 | CAPSCREW,20MMX50MM,(2.5),10.9 |
| 18 | 06420144 | 1 | SPACER,CRNKSHFT,T6020 |
| 19 | 6T0389 | 1 | ADPTR,DRV SHFT,NH,ASSY |
| 20 | 6T0375B | 1 | COUPLING,14 SPLINE,W/ZERK |
| 21 | 21732 | 4 | CAPSCREW,1/2" X 1-3/4", NC |
| 22 | 06533004 | 8 | FLATWASHER,1/2" |
| 23 | 06380042 | 1 | MOUNT,PUMP |
| 24 | 21725 | 4 | HEX NUT,1/2", NC |
| 25 | 23152 | 1 | PUMP |
| 26 | 06420187 | 1 | DRIVESHAFT |
| 27 | 06535000 | 4 | CAPSCREW,7/16" X 1-1/4" CUTOFF |
| 28 | 06300223 | 1 | MAINFRAME |
| 29 | 06401912 | 1 | PLATE,CLAMP,AXLE |
| 30 | 06300279 | 1 | AXL BRC,RH,TS6.1XX,T4B,RS |

TRACTOR MOUNT KIT - HYDRAULICS

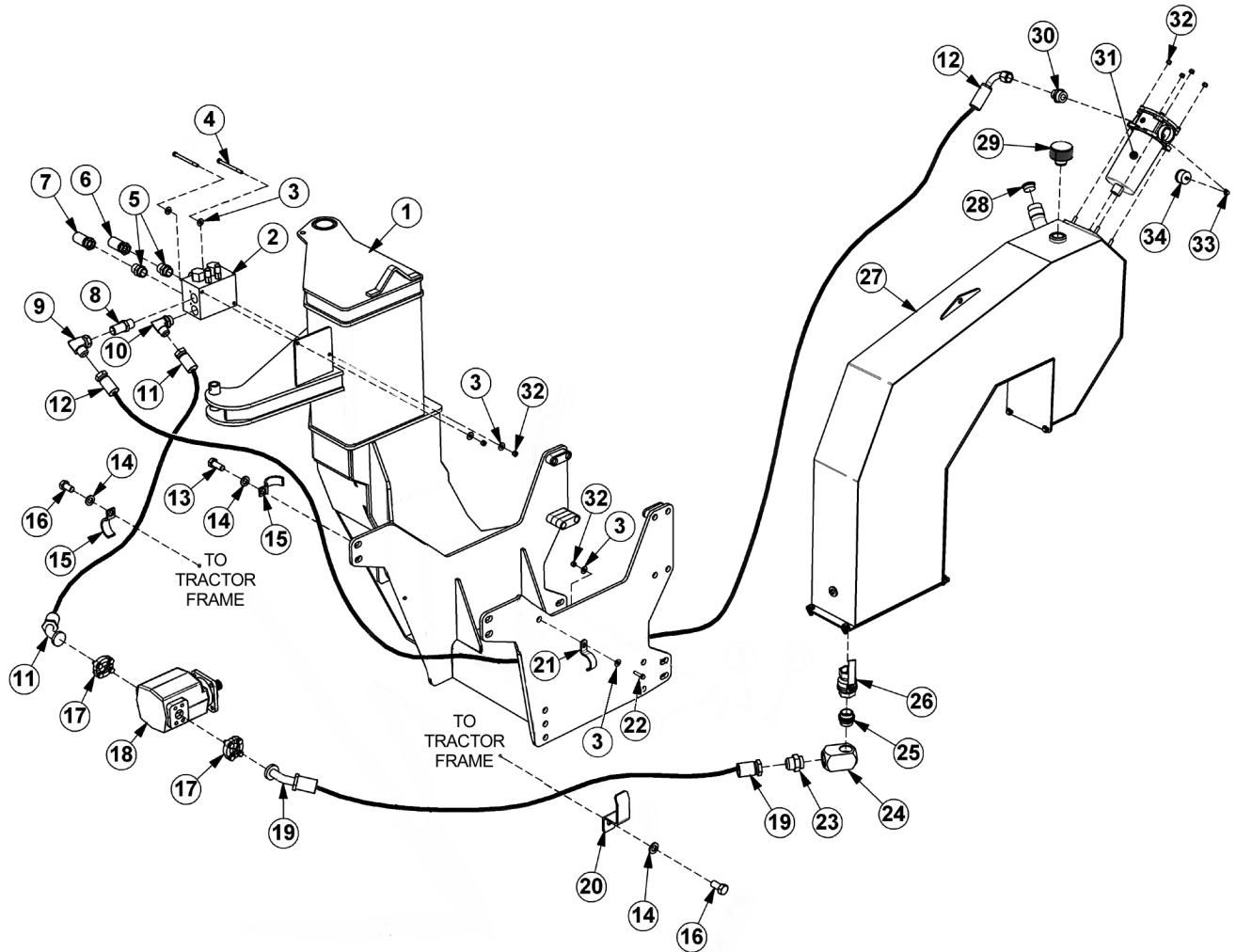

TRACTOR MOUNT KIT - HYDRAULICS

Continued...

| ITEM | PART NO. | QTY. | DESCRIPTION |
|------|----------|------|---|
| 1 | ----- | - | MAINFRAME* REFER TO TRACTOR MOUNT PAGE* |
| 2 | 06510083 | 1 | VALVE,BRAKE,SOL,3000PSI |
| 3 | 22016 | 5 | FLATWASHER,3/8",GR8 |
| 4 | 21644 | 2 | CAPSCREW,3/8" X 5" NC |
| 5 | 33555 | 2 | ADAPTER,1"MB X 1"MJ |
| 6 | 06500754 | 1 | HOSE, 1" X 105" |
| 7 | 06500753 | 1 | HOSE, 1" X 103" |
| 8 | 32869 | 1 | NIPPLE,MALE LONG,1"MOR X 1"MJ |
| 9 | 33259 | 1 | ELBOW,1"MJ X 1"FJX 90° |
| 10 | 34117 | 1 | ELBOW,1"MB X 1"MJ,FORGED |
| 11 | 06500274 | 1 | HOSE, 1" X 74" |
| 12 | 06500820 | 1 | HOSE, 1" X 188" |
| 13 | 31731 | 1 | CAPSCREW,20MMX50MM,(2.5P),10.9 |
| 14 | 33880 | 3 | FLATWASHER,3/4",GR 8 |
| 15 | TB3012 | 2 | CLAMP,CROSSOVER TUBE |
| 16 | 24860 | 2 | CAPSCREW,20MMX40MM(2.5P)10.9 |
| 17 | TF4852 | 2 | KIT,FLANGE,#20 |
| 18 | 23152 | 1 | PUMP |
| 19 | 06500780 | 1 | HOSE,1-1/2" X 114" |
| 20 | 06411136 | 1 | CLAMP,HOSE,2.0 |
| 21 | 32382 | 1 | BRACKET,HOSE |
| 22 | 21632 | 1 | CAPSCREW,3/8" X 1-1/2" NC |
| 23 | 34710 | 1 | ADAPTER,1-1/2"ORB X 1-1/2"MJ |
| 24 | 06503084 | 1 | ELBOW,1-1/2" FB X 1-1/2"FB |
| 25 | 06503083 | 1 | ADAPTER,1-1/2"ORB X 1-1/2"ORB |
| 26 | 34309 | 1 | BALL VALVE,1-1/2" FOR |
| 27 | ----- | - | TANK ASSY*REFER TO TRACTOR MOUNT PAGE* |
| 28 | 06505127 | 1 | PLUG,SAE 3/4" |
| 29 | 06505077 | 1 | CAP,BREATHER,O-RING |
| 30 | 34064 | 1 | ADAPTER,1-1/4" MOR X 1"MJ |
| 31 | 06505044 | 1 | FLTR ASSY,IN-TANK CPLT,SAE10MP |
| 32 | 21627 | 7 | NYLOCK NUT,3/8" NC |
| 33 | 6T0649 | 1 | FILTER GAUGE |
| 34 | TF4888 | 1 | STREET ELBOW,1/8" X 90° |

ELECTRONIC PROPORTIONAL LIFT VALVE MOUNT

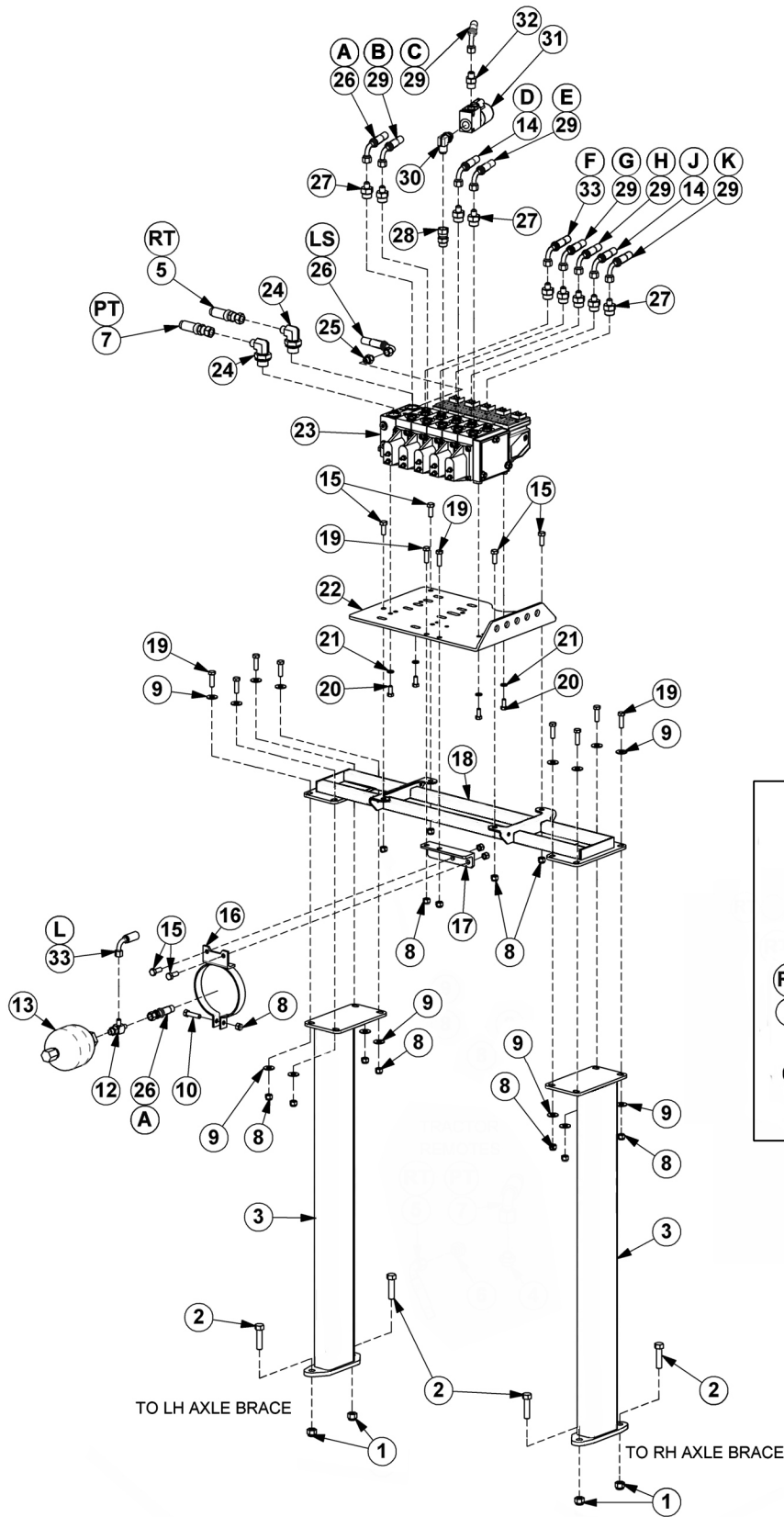

HOSE ROUTING

- A- LIFT VALVE TO ACCUMULATOR
- B- TO SECONDARY BOOM CYL GLAND
- C- TO DECK ROLL CYL GLAND
- D- TO BOOM SWIVEL CYL BUTT
- E- TO SAFETY SHIELD CYL GLAND
- F- TO MAIN BOOM CYL BUTT
- G- TO SECONDARY BOOM CYL BUTT
- H- TO DECK ROLL CYL BUTT
- J- TO BOOM SWIVEL CYL GLAND
- K- TO SAFETY SHIELD CYL BUTT
- L- TO MAIN BOOM CYL GLAND
- PT- PRESSURE FROM TRACTOR
- RT- RETURN TO TRACTOR
- LS- LOAD SENSE
- TL- TRACTOR LOAD SENSE

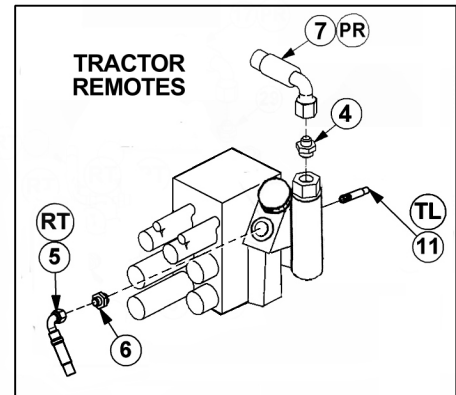
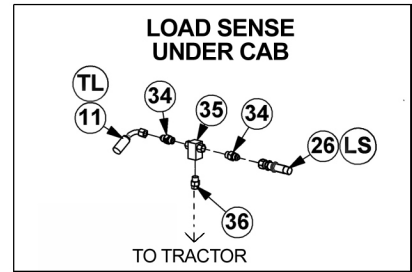

ELECTRONIC PROPORTIONAL LIFT VALVE MOUNT

Continued...

| ITEM | PART NO. | QTY. | DESCRIPTION |
|------|----------|------|----------------------------|
| 1 | 21727 | 4 | NYLOCK NUT,1/2 NC |
| 2 | 21733 | 4 | CAPSCREW,1/2 X 2 NC |
| 3 | 06340056 | 2 | VLV MNT,LEG,TS6.1XX,T4B |
| 4 | 06503167 | 1 | ADAPTER,BANJO,3/4 |
| 5 | 33410 | 1 | HOSE, 1/2" X 48" |
| 6 | 06503059 | 1 | ADAPTER,5/8MJX3/4BSPP |
| 7 | 06500339 | 1 | HOSE, 1/2" X 35" |
| 8 | 21627 | 17 | NYLOCK NUT,3/8 NC |
| 9 | 22016 | 16 | FLATWASHER,3/8,GR8 |
| 10 | 21632 | 1 | CAPSCREW,3/8 X 1-1/2 NC |
| 11 | 06500594 | 1 | HOSE, 1/4" X 28" |
| 12 | 06503029 | 1 | TEE,RUN,1/2ORB3/8MJX3/8MJ |
| 13 | 24300 | 1 | ACCUMULATOR |
| 14 | 06500149 | 2 | HOSE, 1/4" X 220" |
| 15 | 21630 | 6 | CAPSCREW,3/8 X 1 NC |
| 16 | 23888 | 1 | BRKT,ACCUMULATOR |
| 17 | 06460072 | 1 | BRKT,MNT,ACCUM,JD6R |
| 18 | 06340057 | 1 | VLV MNT,TS6.1XX,T4B |
| 19 | 21631 | 10 | CAPSCREW,3/8X1 1/4, NC,GR8 |
| 20 | 21579 | 4 | CAPSCREW,5/16 X 3/4 NC |
| 21 | 21987 | 4 | LOCKWASHER,5/16 |
| 22 | 34622 | 1 | PLATE,VALVE,REAR MNT |
| 23 | 06502097 | 1 | VLV,5SP,DF,PVEA,RS |
| 24 | 33294 | 2 | ELBOW,3/4MBX1/2MJ |
| 25 | 33392 | 1 | ADAPTER,5/16MBX3/8MJ |
| 26 | 06500450 | 2 | HOSE, 1/4" X 42" |
| 27 | 32807 | 9 | ADAPTER,5/8MBX3/8MJ |
| 28 | 06503041 | 1 | ADAPTER,5/8ORBX1/2FJX |
| 29 | 06500687 | 6 | HOSE, 1/4" X 268" |
| 30 | 33382 | 1 | ELBOW,1/2MBX1/2MJ |
| 31 | 06510050 | 1 | TRV LCK,METRIPACK COIL |
| 32 | 33271 | 1 | ADAPTER,1/2 MOR X 3/8 MJ |
| 33 | 06500688 | 2 | HOSE,1/4" X 288" |
| 34 | 32901 | 2 | ADAPTER,3/8 MOR X 3/8 MJ |
| 35 | 3338806 | 1 | TEE,SHUTTLE,3/8 FOR |
| 36 | 06503166 | 1 | ADAPTER,3/8MBX1/4FJX |

NH TS6.1XX BENGAL T4B

JOYSTICK AND SWITCHBOX MOUNT

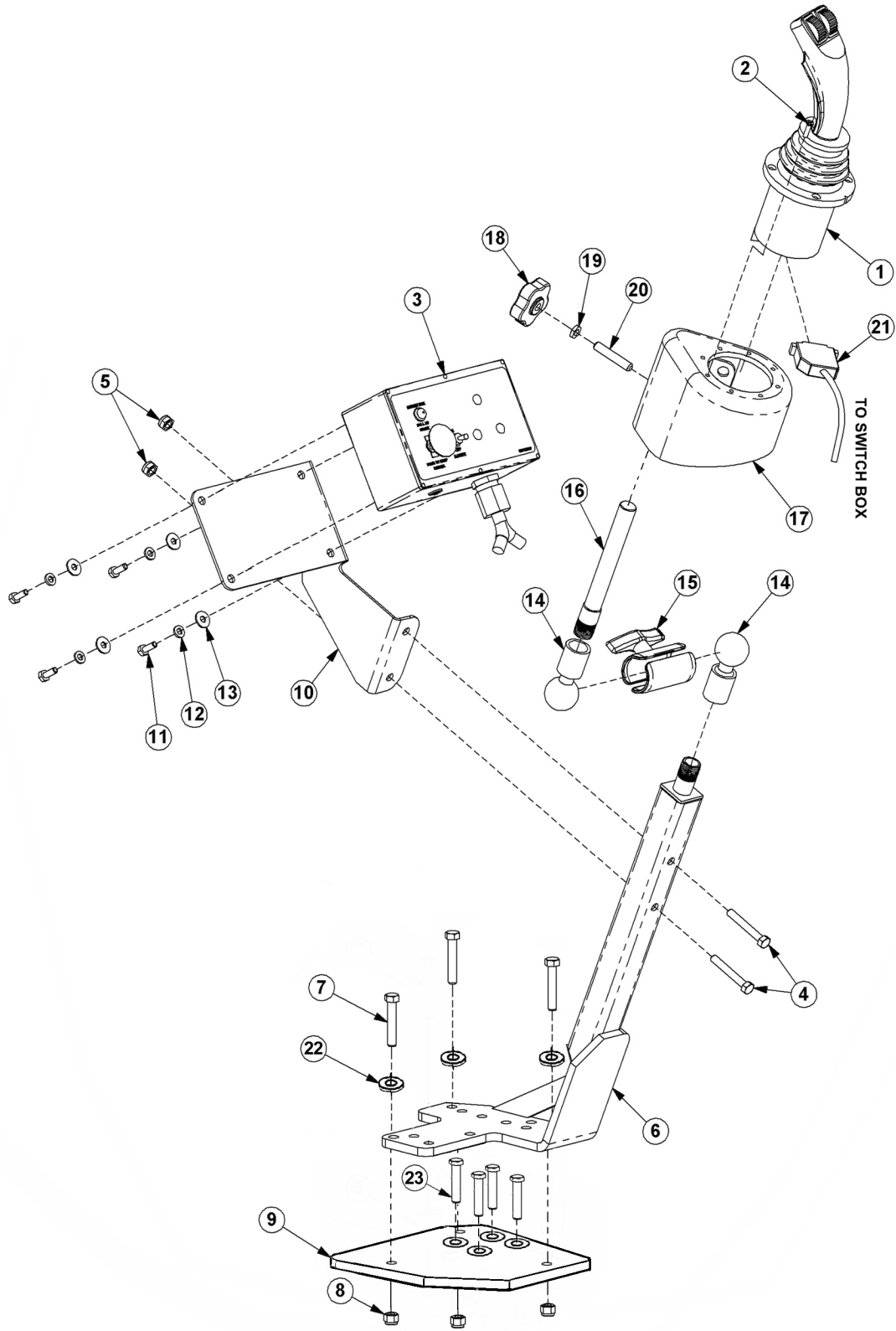

JOYSTICK AND SWITCHBOX MOUNT

Continued...

| ITEM | PART NO. | QTY. | DESCRIPTION |
|------|----------|------|-----------------------------------|
| 1 | 33691 | 1 | JOYSTICK |
| 2 | 32829 | 4 | SCREW,MACHINE,10-32 X 3/4",FLATHD |
| 3 | 06510196 | 1 | SWITCH BOX,DF,SS,OS |
| 4 | 21585 | 2 | CAPSCREW,5/16" X 2-1/4",NC |
| 5 | 21577 | 2 | NYLOCK NUT,5/16",NC |
| 6 | 06340011 | 1 | MNT,STND,JOYSTICK |
| 7 | 21631 | 3 | CAPSCREW,3/8" X 1-1/4",NC, GR8 |
| 8 | 21627 | 3 | NYLOCK NUT,3/8",NC |
| 9 | 06380081 | 1 | MNT, STND, CNTRL, TS6 1XX T4B |
| 10 | 06340015 | 1 | SWITCH BOX MNT |
| 11 | 21529 | 4 | CAPSCREW,1/4" X 3/4",NC |
| 12 | 21986 | 4 | LOCKWASHER,1/4" |
| 13 | 22014 | 4 | FLATWASHER,1/4" |
| 14 | 06520041 | 2 | MOUNT,RAM,BALL,1-1/2" |
| 15 | 06520020 | 1 | MOUNT,RAM,ARM |
| 16 | 06340010 | 1 | ROD,1/2"NPT X 7" |
| 17 | 35033 | 1 | CAN,JOYSTICK,ASSY |
| 18 | 35204 | 1 | KNOB,3/8",NC,INSERT |
| 19 | 35206 | 1 | HEX NUT,JAMB,3/8",NC |
| 20 | 35205 | 1 | SETSCREW,3/8" X 2",NC,KNURLED |
| 21 | 33693 | 1 | CBL,EXT,4FT,JOYSTICK |
| 22 | 22015 | 6 | FLATWASHER, 5/16" |
| 23 | 06530108 | 4 | CAPSCREW, 8MM X 70MM 1.25 |

BATTERY RELOCATION

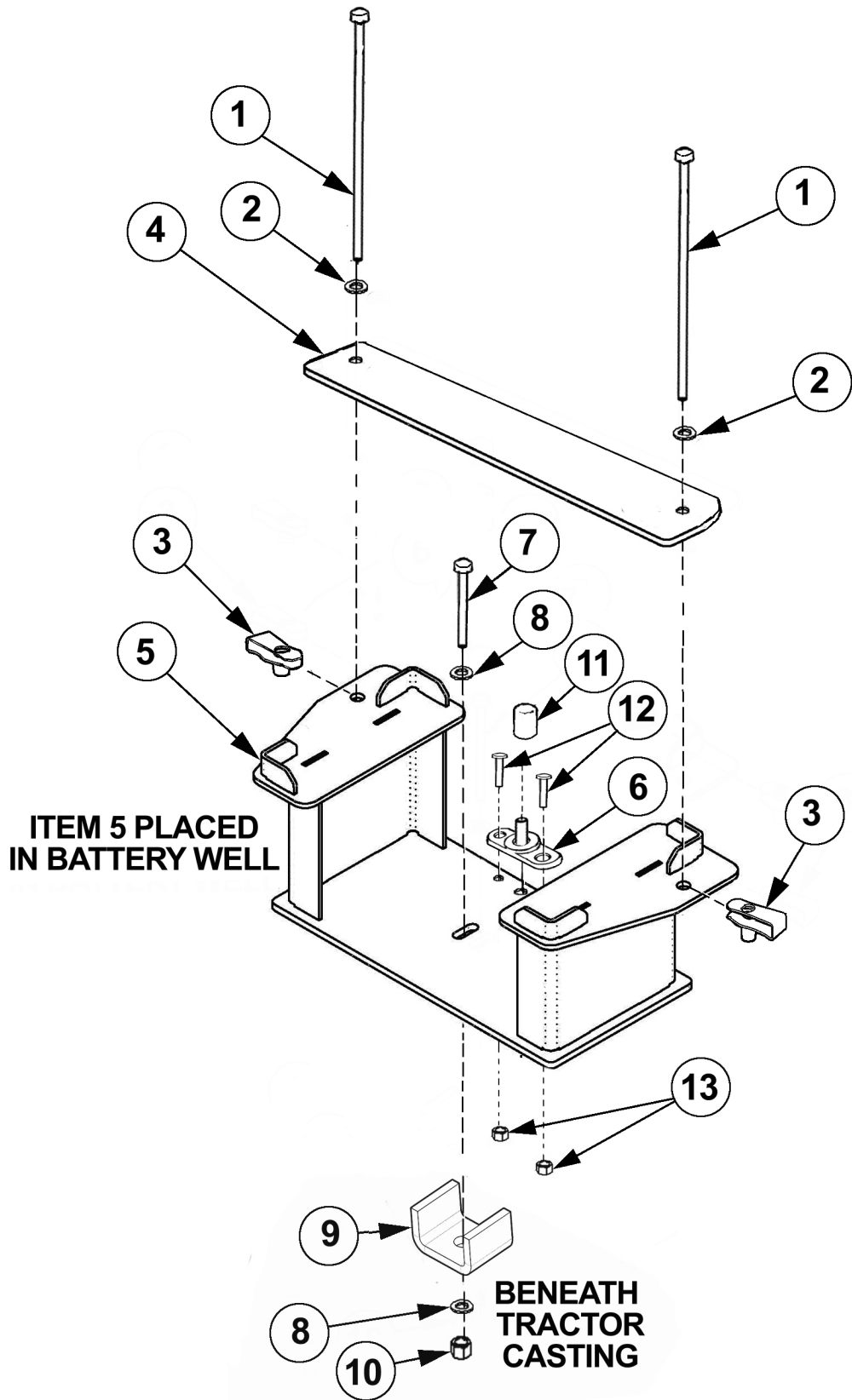

BATTERY RELOCATION

Continued...

| ITEM | PART NO. | QTY. | DESCRIPTION |
|------|----------|------|-------------------------------|
| 1 | 06530234 | 2 | CAPSCREW, 1/4" X 10" NC |
| 2 | 22014 | 2 | FLATWASHER, 1/4" |
| 3 | 35176 | 2 | U-NUT, 1/4" 3/4" TO CENTER |
| 4 | 06412376 | 1 | BATTERY STRAP |
| 5 | 06370267 | 1 | RELOC, BATT, NH TS6 T4B |
| 6 | 06512019 | 1 | JUNCTION BLOCK, 3/8 STUD, RED |
| 7 | 21587 | 1 | CAPSCREW, 5/16" X 2-3/4" NC |
| 8 | 22015 | 2 | FLATWASHER, 5/16" |
| 9 | 06412377 | 1 | CLAMP, BATTERY, BTM, TS6 T4B |
| 10 | 21577 | 1 | NYLOCK NUT, 5/16" NC |
| 11 | 06510261 | 1 | POST, BATT, POS |
| 12 | 06530304 | 2 | SCREW, MACHINE, 10-24 X 3/4" |
| 13 | 24890 | 2 | HEX NUT, 10-24, NYLOCK |

POLYCARBONATE

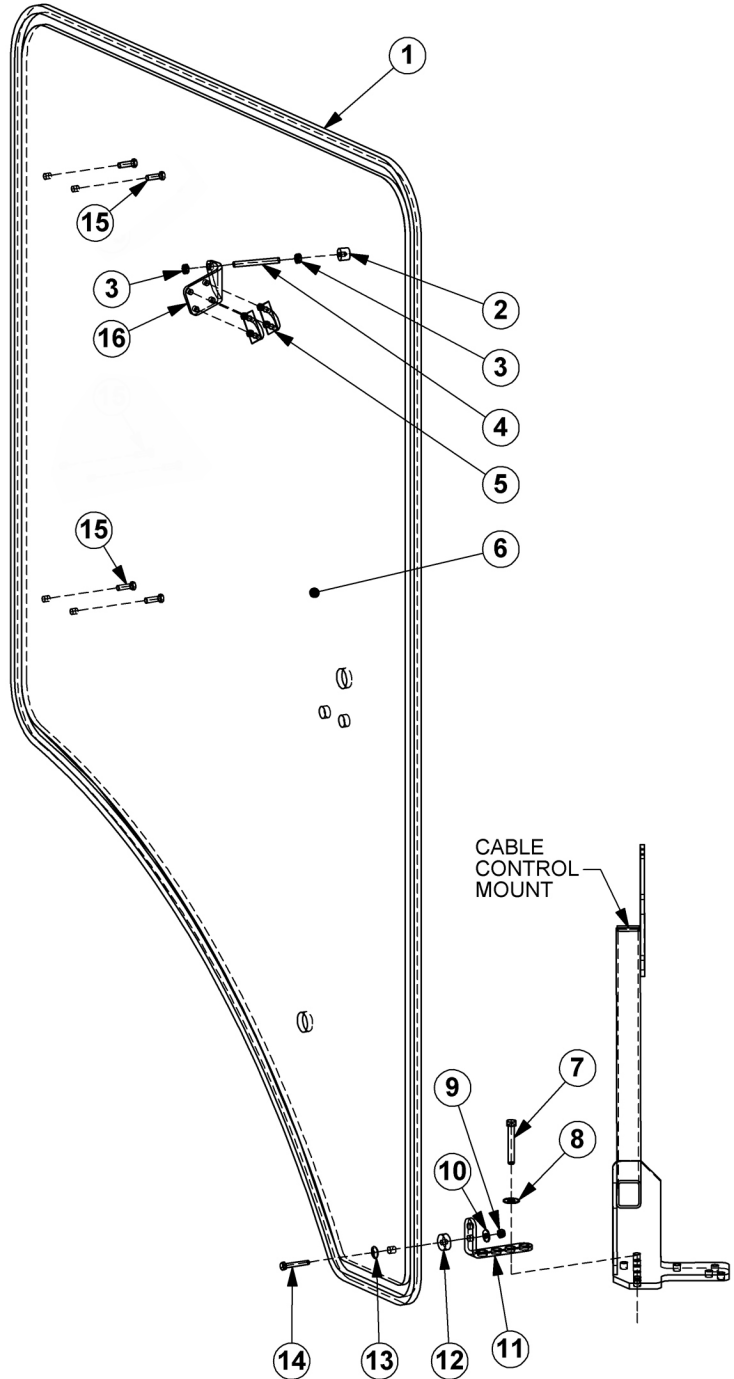
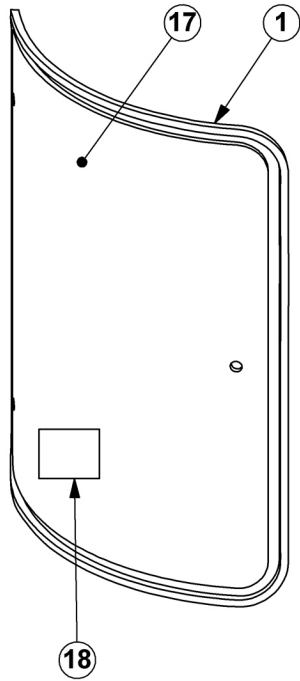

ITEM 5 CLAMPS AROUND
MIRROR BRACKET

ITEM 7 REPLACES
HARDWARE FOR CABLE
CONTROL MOUNT

ITEM 15 REPLACES
EXISTING HARDWARE

POLYCARBONATE

Continued...

| ITEM | PART NO. | QTY. | DESCRIPTION |
|------|----------|------|---------------------------|
| 1 | 31965 | 25 | TRIMLOCK (IN FEET) |
| 2 | 33477 | 1 | ISOLATOR |
| 3 | 21575 | 2 | HEX NUT,5/16",NC |
| 4 | 33478 | 1 | ROD,THREADED,5/16" X 3" |
| 5 | 32550 | 2 | U-BOLT,ASSY |
| 6 | 06490049 | 1 | POLYCARBONATE,DOOR |
| 7 | 21632 | 1 | CAPSCREW,3/8" X 1-1/2",NC |
| 8 | 22016 | 1 | FLATWASHER,3/8" |
| 9 | 21527 | 1 | NYLOCK NUT,1/4",NC |
| 10 | 22014 | 1 | FLATWASHER,1/4" |
| 11 | 06410672 | 1 | BRACKET,BOTTOM |
| 12 | 06537000 | 1 | WASHER,NEOPRENE |
| 13 | 06537001 | 1 | WASHER,RUBBER |
| 14 | 21533 | 1 | CAPSCREW,1/4" X 1-3/4",NC |
| 15 | 28583 | 4 | CAPSCREW,8MM X 25MM,1.25P |
| 16 | 06411620 | 1 | BRACKET, TOP |
| 17 | 06490050 | 1 | POLYCARBONATE,REAR |
| 18 | 22645 | 1 | DECAL |

WHEEL WEIGHT

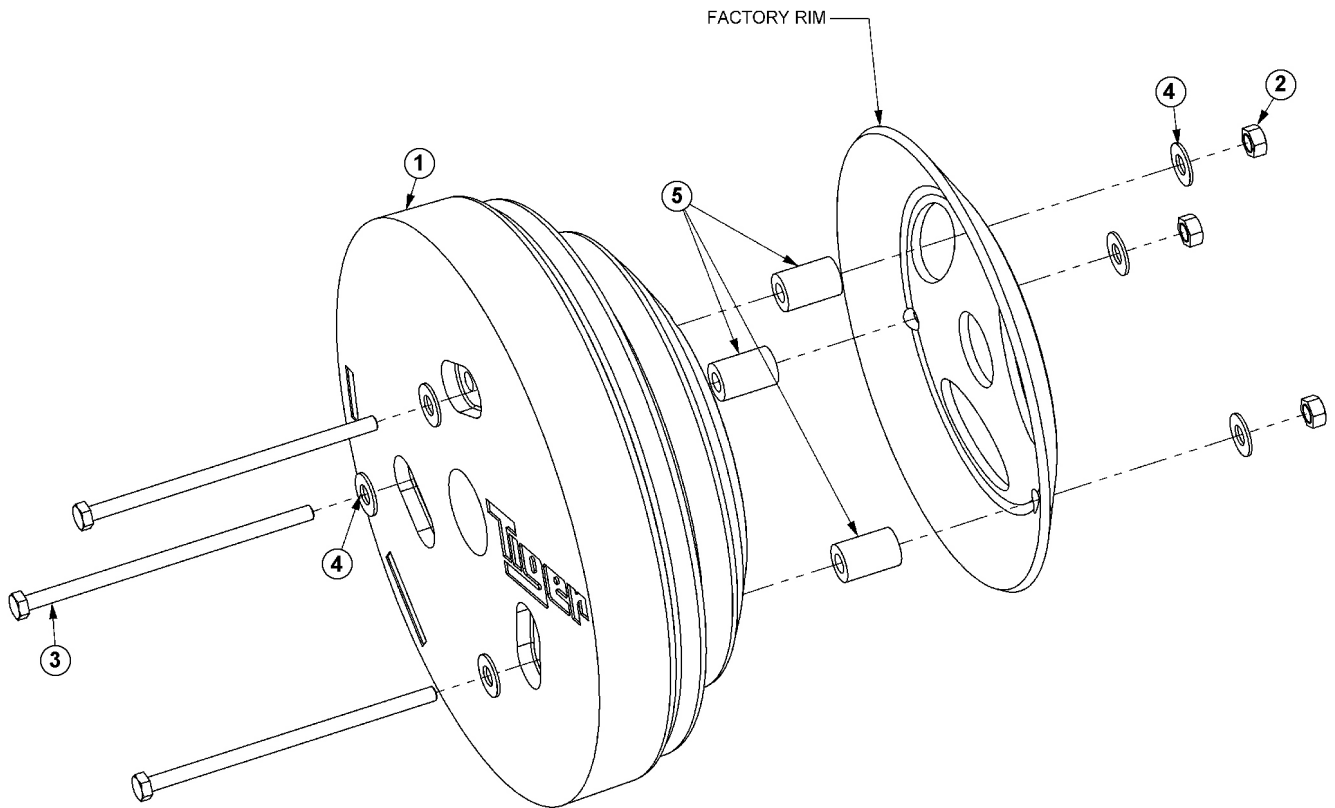

| ITEM | PART NO. | QTY. | DESCRIPTION |
|------|----------|------|-------------------------------|
| 1 | 32517 | 1 | WHEEL WEIGHT, 1700# |
| 2 | 06531000 | 3 | HEX NUT, 7/8", NC |
| 3 | 06530213 | 3 | CAPSCREW, 7/8" X 16", NC, GR8 |
| 4 | 06533000 | 6 | FLATWASHER, 7/8" |
| 5 | TB3278 | 3 | SPACER |

BENGAL

COMMON PARTS

NOTES

NOTES

PART NAME INDEX

| | |
|---|----|
| RCTVUQTFGT&I 'I W&G(| 7 |
| DQO 'CUU] 'DGP I CN'3: "V6(| 8 |
| DQO 'CUU] 'DGP I CN'UVPFCTF "44"V6(| : |
| DQO 'CUU] 'J [F'DGP I CN'44"V6(| 32 |
| DQO 'CUU] 'DGP I CN'GZV'46"V6(| 34 |
| DQO 'CUU] 'J [F'DGP I CN'46"V6(| 36 |
| DQO TGVV/'QRGP "UVQY (| 38 |
| 72R "TQVCT['O QY GT'CUUGO DN[(| 3: |
| 72R "TQVCT['MP &GU'CPF 'F KU (| 42 |
| 72R "TQVCT['DNCF G'DCT'CPF 'MP &GU(| 43 |
| 82R "TQVCT['O QY GT'CUUGO DN[(| 44 |
| 82R "TQVCT['MP &GU'CPF 'F KU (| 46 |
| 82R "TQVCT['DNCF G'DCT'CPF 'MP &GU(| 47 |
| TQVCT['O QY GT'UR&FNG'CUUGO DN[(| 48 |
| DQO 'TQVCT['R&QV'CUUGO DN[(| 4: |
| 72R 'HCK'FT&G'CUUGO DN[(| 52 |
| 72R 'HCK'O QY GT'CUUGO DN[(| 54 |
| 72R 'HCK'O QY GT'CUU] .RCUU/VJ TQW J 'MP &GU(| 56 |
| 85R 'HCK'FT&G'CUUGO DN[(| 58 |
| 85R 'HCK'O QY GT'CUUGO DN[(| 5: |
| DQO 'HCK'R&QV'CUUGO DN[(| 62 |
| 5R 'Z'35/9: 'R 'Y GNF GF 'E[NR F GT'DTGCMF QY P(| 64 |
| 5R 'Z'3: 'R 'Y GNF GF 'E[NR F GT'DTGCMF QY P0 | 65 |
| 5/3 4R 'Z'42R 'Y GNF GF 'E[NR F GT'DTGCMF QY P(| 66 |
| 6R 'Z'42R 'Y GNF GF 'E[NR F GT'DTGCMF QY P0 | 67 |
| 7R 'Z'42R 'Y GNF GF 'E[NR F GT'DTGCMF QY P0 | 68 |
| P QVGL(| 69 |
| 7"URQQN'GNGEVTQP &"XCNXG"/"QRGP "UVQY .5RU(| 6: |
| 7"URQQN'GNGEVTQP &"XCNXG"/"UF G'UVQY (| 72 |
| HTQP V'J [F T C W N & 'R W O R(| 74 |
| 72R 'CPF'82R "TQVCT['O QVQT'DTGCMF QY P(| 76 |
| HCK'O QVQT'DTGCMF QY P(| 78 |
| TGUGT X Q K T "VCP M H K V G T "CUUGO DN[(| 7: |
| RWO R'CPF 'I T & N 'I W C T F "QRVQ P (| 7; |
| DQO "VTCXGN'NQEM(| 82 |
| O C P W C N 'N & H "X C N X G "U Y K V E J "D Q Z(| 83 |
| O C P W C N 'N & H "X C N X G "U E J G O C V & (| 84 |
| G N G E V T Q P & "N & H "X C N X G "U Y K V E J "D Q Z (| 85 |
| G N G E V T Q P & "N & H "X C N X G "U E J G O C V & (| 86 |
| U Q N G P Q & "U Y K V E J "D Q Z "C P F "Y K T & I (| 87 |

COMMON BENGAL T4

PARTS ORDERING GUIDE

The following instructions are offered to help eliminate needless delay and error in processing purchase orders for the equipment in this manual.

1. The Parts Section is prepared in logical sequence and grouping of parts that belong to the basic machine featured in this manual. Part Numbers and Descriptions are given to help locate the parts and quantities required.
2. The Purchase Order must indicate the **Name and Address** of the person or organization ordering the parts, **who should be charged**, and if possible, the **serial number of the machine** for which the parts are being ordered.
3. The purchase order must clearly list the **quantity of each part**, the complete and correct **part number**, and the basic **name of the part**.
4. The manufacturer reserves the right to substitute parts where applicable.
5. Some parts may be unlisted items which are special production items not normally stocked and are subject to special handling. Request a quotation for such parts before sending a purchase order.
6. The manufacturer reserves the right to change prices without prior notice.

NOTE: When ordering replacement decals, refer to the part numbers and descriptions listed in the safety section in the front of this manual.

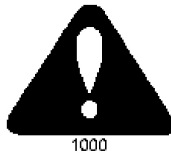

For maximum safety and to guarantee optimum product reliability, always use genuine **Tiger** replacement parts. The use of inferior replacement parts may cause premature or catastrophic failure which could result in serious injury or death.

Direct any questions regarding parts to:

Tiger Corporation
3301 N. Louise Ave.
Sioux Falls, SD 57107
1-800-843-6849
1-605-336-7900

BOOM ASSY - BENGAL 18 T4

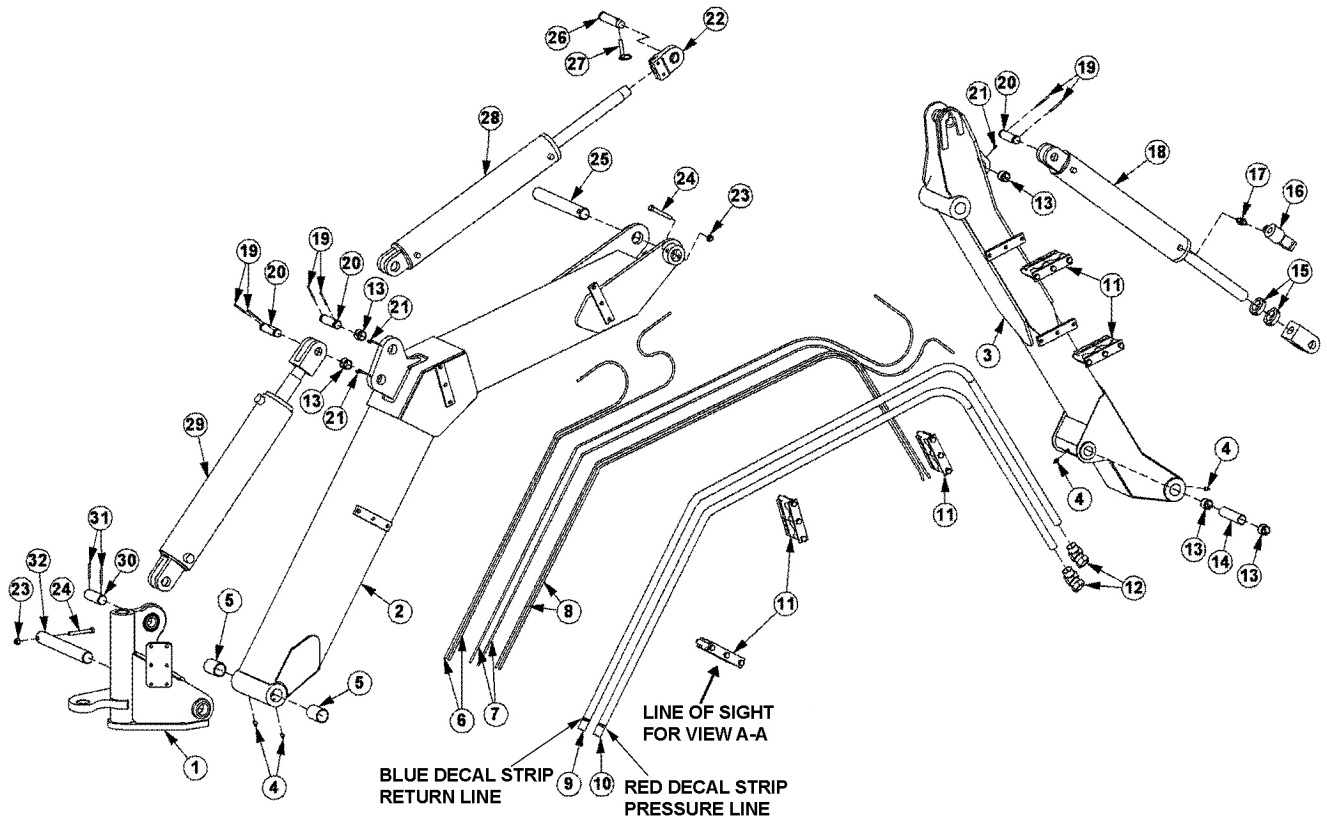

NOTES:

1. IMPORTANT: ALIGN GREASE HOLE OR GAP IN BEARING (ITEMS 5 & 13) WITH GREASE ZERK IN BOOM. MAINTAIN ALIGNMENT DURING BEARING INSTALLATION.
2. GREASE HINGE PIN ZERKS (ITEM 4) ON BOOM AFTER ASSEMBLY, ONCE UNDER LOAD WITH BOOM ELEVATED AND AGAIN AT REST WITH BOOM SUPPORTED.
3. ONLY ONE SET COLLAR (ITEM 15) NEEDED FOR ROTARY MOWERS.

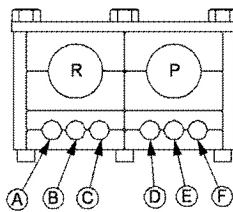

VIEW A-A

KEY

- A - SECONDARY BUTT
- B - SECONDARY GLAND
- C - DECK ROLL BUTT
- D - DECK ROLL GLAND
- E - SHIELD BUTT
- F - SHIELD GLAND
- R - RETURN
- P - PRESSURE

BOOM ASSY - BENGAL 18 T4

Continued...

| ITEM | PART NO. | QTY. | DESCRIPTION |
|------|----------|------|---------------------------------|
| 1 | ---- | - | REAR STOW SWIVEL ASSY |
| 2 | 06700167 | - | MAIN BOOM ASSY |
| --- | 06310111 | 1 | MAIN BOOM WELDMENT |
| 3 | 06700168 | - | SECONDARY BOOM ASSY |
| ---- | 06310112 | 1 | SECONDARY BOOM WELDMENT |
| 4 | 6T3211 | 4 | GREASE ZERK,1/8" |
| 5 | 32321 | 2 | BEARING, DX, 1-1/2" X 2" |
| 6 | 06500499 | 2 | HOSE,1/4" X 50" |
| 7 | 06500500 | 2 | HOSE,1/4" X 108" |
| 8 | 06500502 | 2 | HOSE,1/4" X 100" |
| 9 | 06500713 | 1 | HOSE,1" X 163" |
| 10 | 06500714 | 1 | HOSE,1" X 162" |
| 11 | 06505116 | 2 | CLAMP KIT |
| 12 | 24724 | 2 | SWIVEL,1MJ X 1FJX45 |
| 13 | TB3010 | 3 | BUSHING |
| 14 | TB1035 | 1 | BUSHING,SPACER |
| 15 | 35312 | 1 | SET COLLAR |
| 16 | 06510050 | 1 | TRAVEL LOCK,METRIPACK COIL |
| 17 | 31329 | 1 | ADAPTER,1/2ORB X 1/2ORB ADJ |
| 18 | 06501023 | 1 | DECK ROLL CYLINDER,3" X 18" |
| 19 | 06537021 | 6 | ROLL PIN,5MM |
| 20 | TB1033 | 4 | PIN,1" |
| 21 | 6T3207 | 4 | GREASE ZERK,1/4" |
| 22 | TB3033 | 1 | CLEVIS WITH SPHERICAL BEARING |
| 23 | 21677 | 2 | NYLOCK NUT,7/16",NC |
| 24 | 21688 | 2 | CAPSCREW,7/16" X 3-1/4",NC |
| 25 | TB1025 | 1 | PIN,1-1/2" |
| 26 | TB1036 | 1 | PIN,1" |
| 27 | TF1143 | 1 | PIN,LYNCH |
| 28 | 06501024 | 1 | SECONDARY CYLINDER,3-1/2" X 20" |
| 29 | 06501022 | 1 | MAIN CYLINDER,4" X 20" |
| 30 | 06420100 | 1 | PIN,1-1/4" |
| 31 | TB1023 | 2 | ROLL PIN,7/32" |
| 32 | TB3013C | 1 | PIN,1-1/2" |

COMMON BENGAL T4

BOOM ASSY BENGAL STANDARD 22 T4

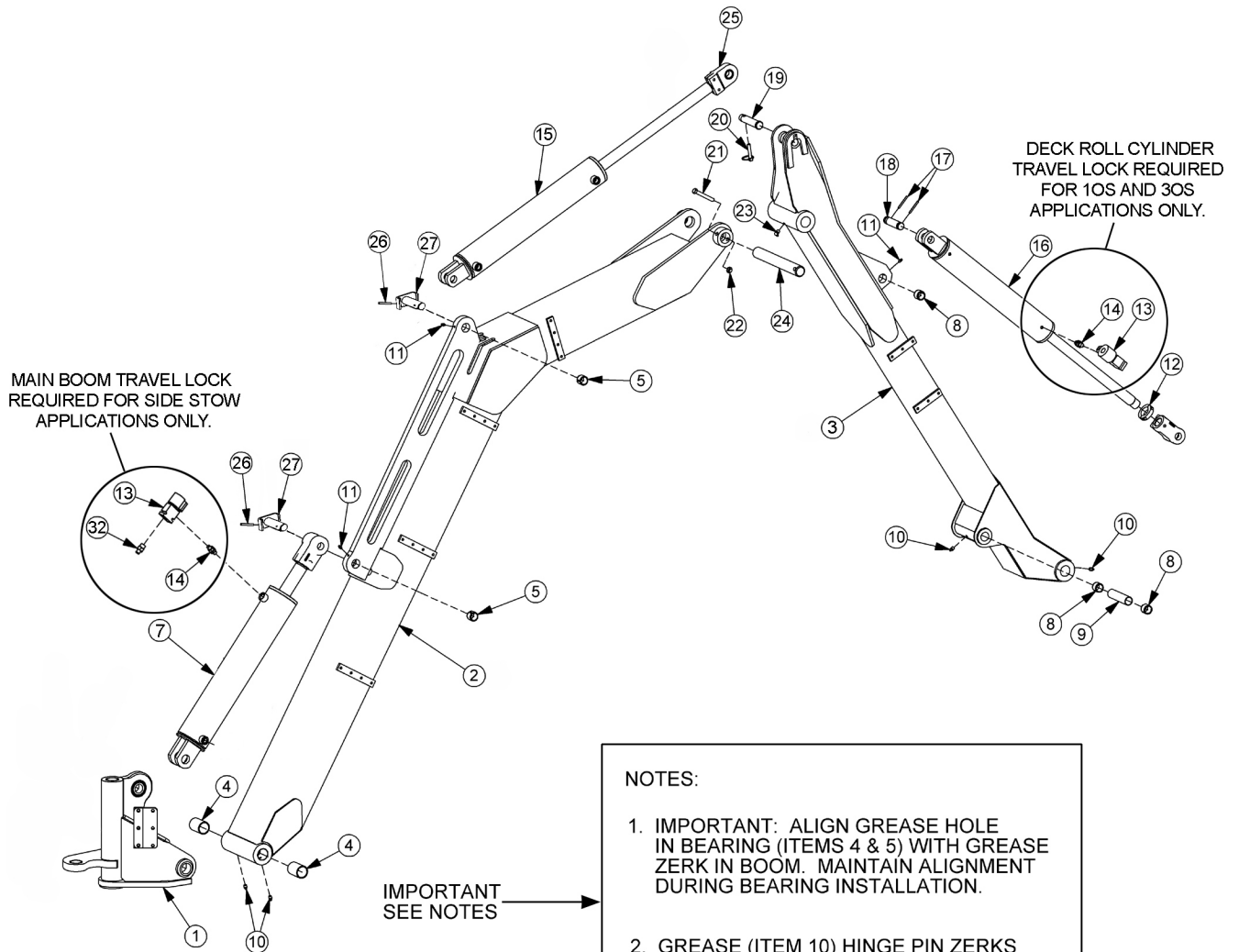

NOTES:

1. IMPORTANT: ALIGN GREASE HOLE IN BEARING (ITEMS 4 & 5) WITH GREASE ZERK IN BOOM. MAINTAIN ALIGNMENT DURING BEARING INSTALLATION.
2. GREASE (ITEM 10) HINGE PIN ZERKS ON BOOM AFTER ASSEMBLY, ONCE UNDER LOAD WITH BOOM ELEVATED AND AGAIN AT REST WITH BOOM SUPPORTED.

BOOM ASSY BENGAL STANDARD 22 T4

Continued...

| ITEM | PART NO. | QTY. | DESCRIPTION |
|-------------|-----------------|-------------|---|
| 1 | ----- | - | SWIVEL ASSY *REFER TO TRACTOR MOUNT KIT |
| 2 | 06700189 | 1 | MAIN BOOM, T4 |
| 3 | 24517 | 1 | SECONDARY BOOM ARM ASSY |
| 4 | 32321 | 2 | BEARING, DX, 1-1/2" X 2" |
| 5 | TB1044 | 2 | BUSHING, 1-1/4"ID |
| 7 | 06501020 | 1 | CYLINDER, 5" X 20" |
| 8 | TB3010 | 3 | BUSHING, 1"ID |
| 9 | TB1035 | 1 | BUSHING,SPACER |
| 10 | 6T3211 | 4 | GREASE ZERK,1/8" |
| 11 | 6T3207 | 3 | GREASE ZERK,1/4 |
| 12 | 35312 | 1 | SET COLLAR |
| 13 | 06510050 | 1 | TRAVEL LOCK,METRIPACK COIL |
| 14 | 31329 | 1 | ADAPTER,1/2ORB X 1/2ORB ADJ |
| 15 | 06501022 | 1 | CYLINDER, 4" X 20" |
| 16 | 06501023 | 1 | CYLINDER,3" X 18" |
| 17 | 06537021 | 6 | ROLL PIN,5MM |
| 18 | TB1033 | 1 | PIN,1" X 4" |
| 19 | TB1036 | 1 | PIN,1" X 4-11/16" |
| 20 | TF1143 | 1 | PIN,LYNCH |
| 21 | 21688 | 2 | CAPSCREW,7/16" X 3-1/4",NC |
| 22 | 21677 | 2 | NYLOCK NUT,7/16",NC |
| 23 | 6T3210 | 1 | GREASE ZERK,1/8" X 90° |
| 24 | TB1025 | 1 | PIN,1-1/2" X 12" |
| 25 | 30172 | 1 | CLEVIS,SPHERICAL |
| 26 | 6T3014 | 2 | ROLL PIN, 1/4" X 2" |
| 27 | TB1045B | 2 | PIN, PRIMARY CYLINDER |

COMMON BENGAL T4

BOOM ASSY HYD BENGAL 22 T4

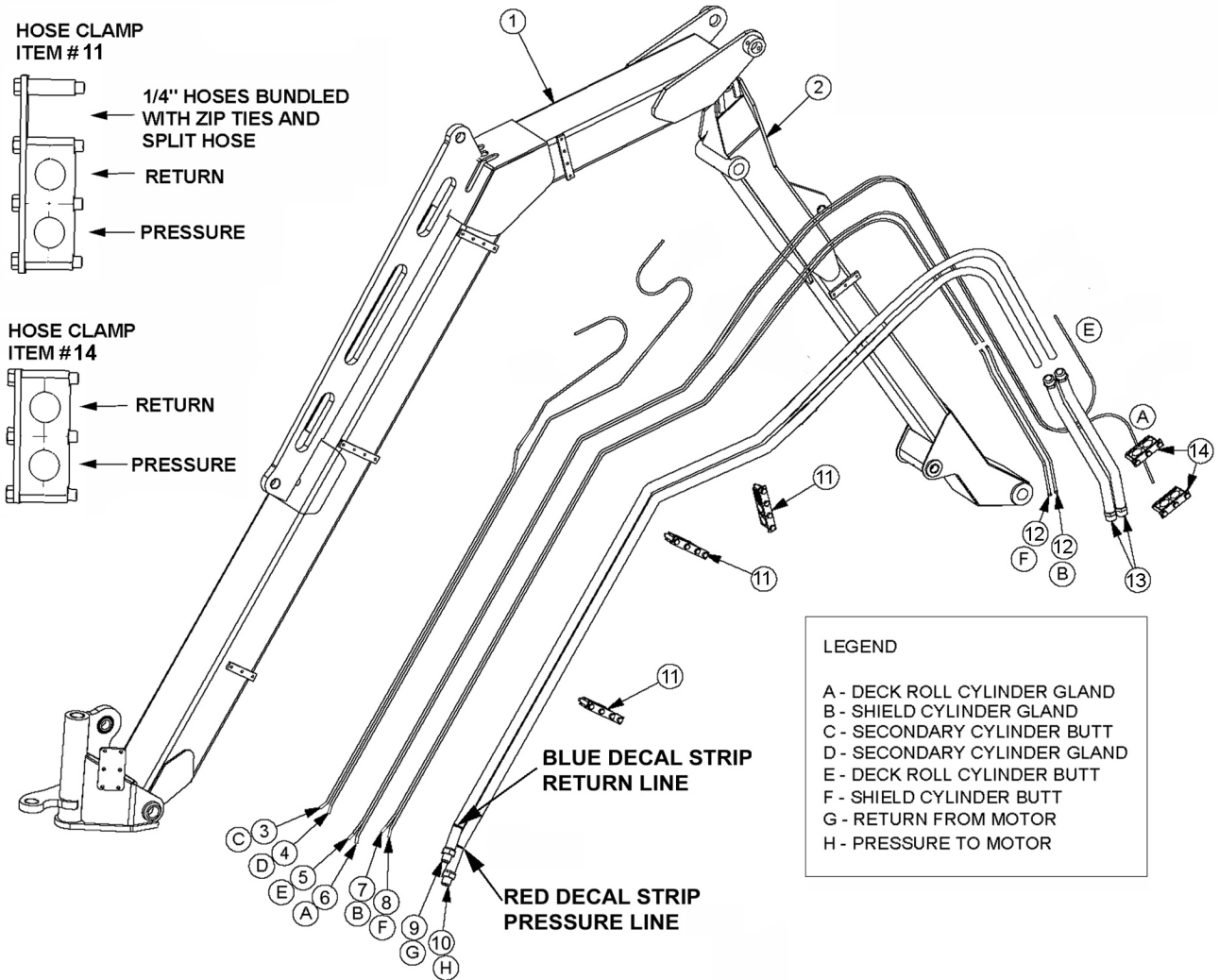

BOOM ASSY HYD BENGAL 22 T4

Continued...

| ITEM | PART NO. | QTY. | DESCRIPTION |
|------|----------|------|--|
| 1 | ----- | - | MAIN BOOM *REFER TO BOOM ARM ASSY |
| 2 | ----- | - | SECONDARY BOOM *REFER TO BOOM ARM ASSY |
| 3 | 06500694 | 1 | HOSE, 1/4" X 83" |
| 4 | --- | 1 | HOSE, 1/4" X 83" |
| 5 | 06500695 | 1 | HOSE, 1/4" X 138" |
| 6 | ---- | 1 | HOSE, 1/4" X 138" |
| 7 | 06500696 | 1 | HOSE, 1/4" X 112" |
| 8 | --- | 1 | HOSE, 1/4" X 112" |
| 9 | 34645 | 1 | HOSE, 1" X 182" |
| 10 | --- | 1 | HOSE, 1" X 182" |
| 11 | 06505019 | 3 | CLAMP KIT,3 SECTION |
| 12 | 34102 | 2 | TUBE,PRFRMD,SEC BOOM |
| 13 | 2403306 | 2 | TUBE,PRFRMD,SEC BOOM,HP |
| 14 | 30111 | 2 | CLAMP KIT,2 SECTION |

COMMON BENGAL T4

BOOM ASSY BENGAL EXT 24 T4

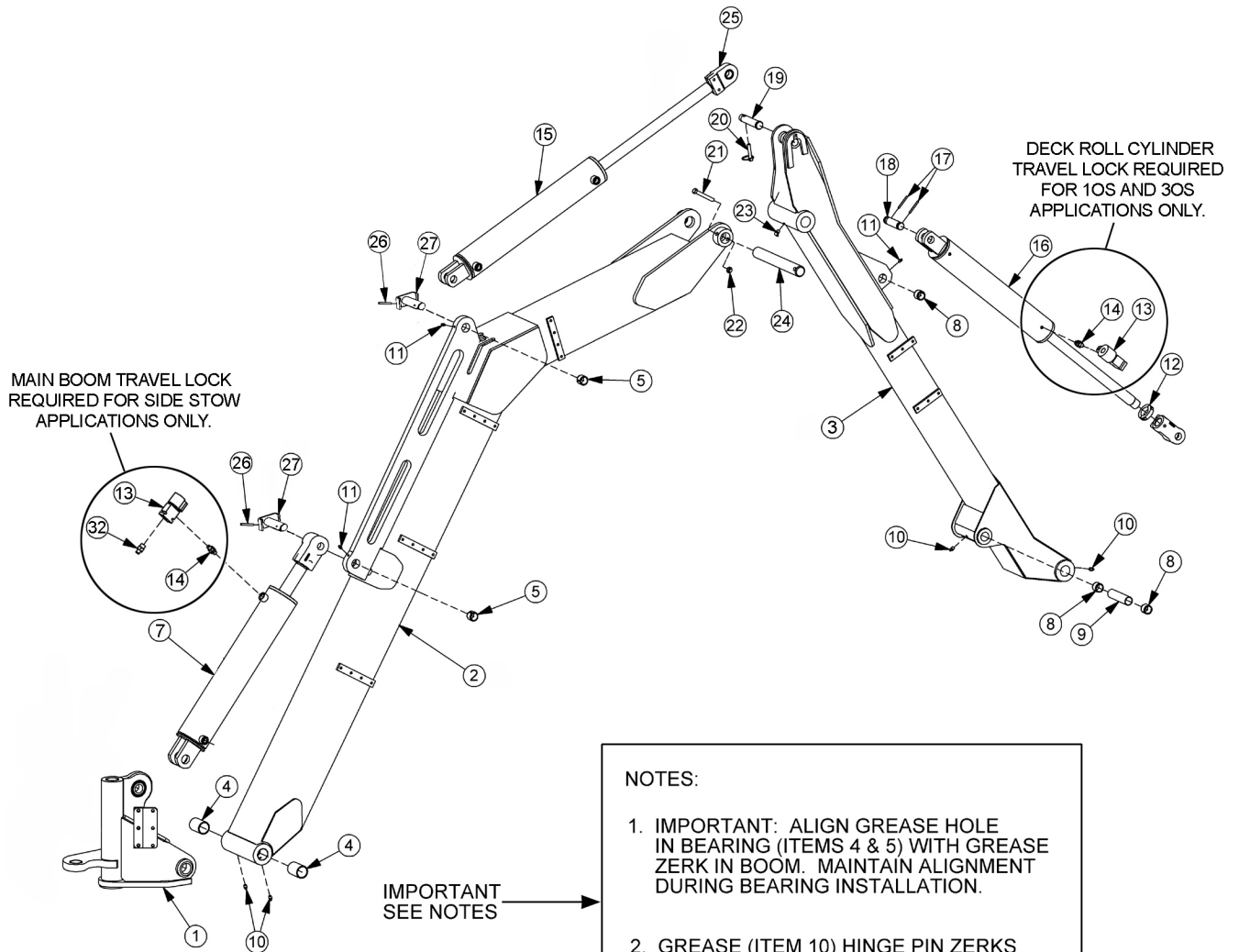

NOTES:

1. IMPORTANT: ALIGN GREASE HOLE IN BEARING (ITEMS 4 & 5) WITH GREASE ZERK IN BOOM. MAINTAIN ALIGNMENT DURING BEARING INSTALLATION.
2. GREASE (ITEM 10) HINGE PIN ZERKS ON BOOM AFTER ASSEMBLY, ONCE UNDER LOAD WITH BOOM ELEVATED AND AGAIN AT REST WITH BOOM SUPPORTED.

BOOM ASSY BENGAL EXT 24 T4

Continued...

| ITEM | PART NO. | QTY. | DESCRIPTION |
|------|----------|------|---|
| 1 | ----- | - | SWIVEL ASSY *REFER TO TRACTOR MOUNT KIT |
| 2 | 06700191 | 1 | MAIN BOOM, EXT, T4 |
| 3 | 06700094 | 1 | SECONDARY BOOM ARM ASSY, EXT, T4 |
| 4 | 32321 | 2 | BEARING, DX, 1-1/2" X 2" |
| 5 | TB1044 | 2 | BUSHING, 1-1/4"ID |
| 7 | 06501020 | 1 | CYLINDER, 5" X 20" |
| 8 | TB3010 | 3 | BUSHING, 1"ID |
| 9 | TB1035 | 1 | BUSHING,SPACER |
| 10 | 6T3211 | 4 | GREASE ZERK,1/8" |
| 11 | 6T3207 | 3 | GREASE ZERK,1/4 |
| 12 | 35312 | 1 | SET COLLAR |
| 13 | 06510050 | 1 | TRAVEL LOCK,METRIPACK COIL |
| 14 | 31329 | 1 | ADAPTER,1/2ORB X 1/2ORB ADJ |
| 15 | 06501022 | 1 | CYLINDER, 4" X 20" |
| 16 | 06501023 | 1 | CYLINDER,3" X 18" |
| 17 | 06537021 | 6 | ROLL PIN,5MM |
| 18 | TB1033 | 1 | PIN,1" X 4" |
| 19 | TB1036 | 1 | PIN,1" X 4-11/16" |
| 20 | TF1143 | 1 | PIN,LYNCH |
| 21 | 21688 | 2 | CAPSCREW,7/16" X 3-1/4",NC |
| 22 | 21677 | 2 | NYLOCK NUT,7/16",NC |
| 23 | 6T3210 | 1 | GREASE ZERK,1/8" X 90° |
| 24 | TB1025 | 1 | PIN,1-1/2" X 12" |
| 25 | 30172 | 1 | CLEVIS,SPHERICAL |
| 26 | 6T3014 | 2 | ROLL PIN, 1/4" X 2" |
| 27 | TB1045B | 2 | PIN, PRIMARY CYLINDER |

COMMON BENGAL T4

BOOM ASSY HYD BENGAL 24 T4

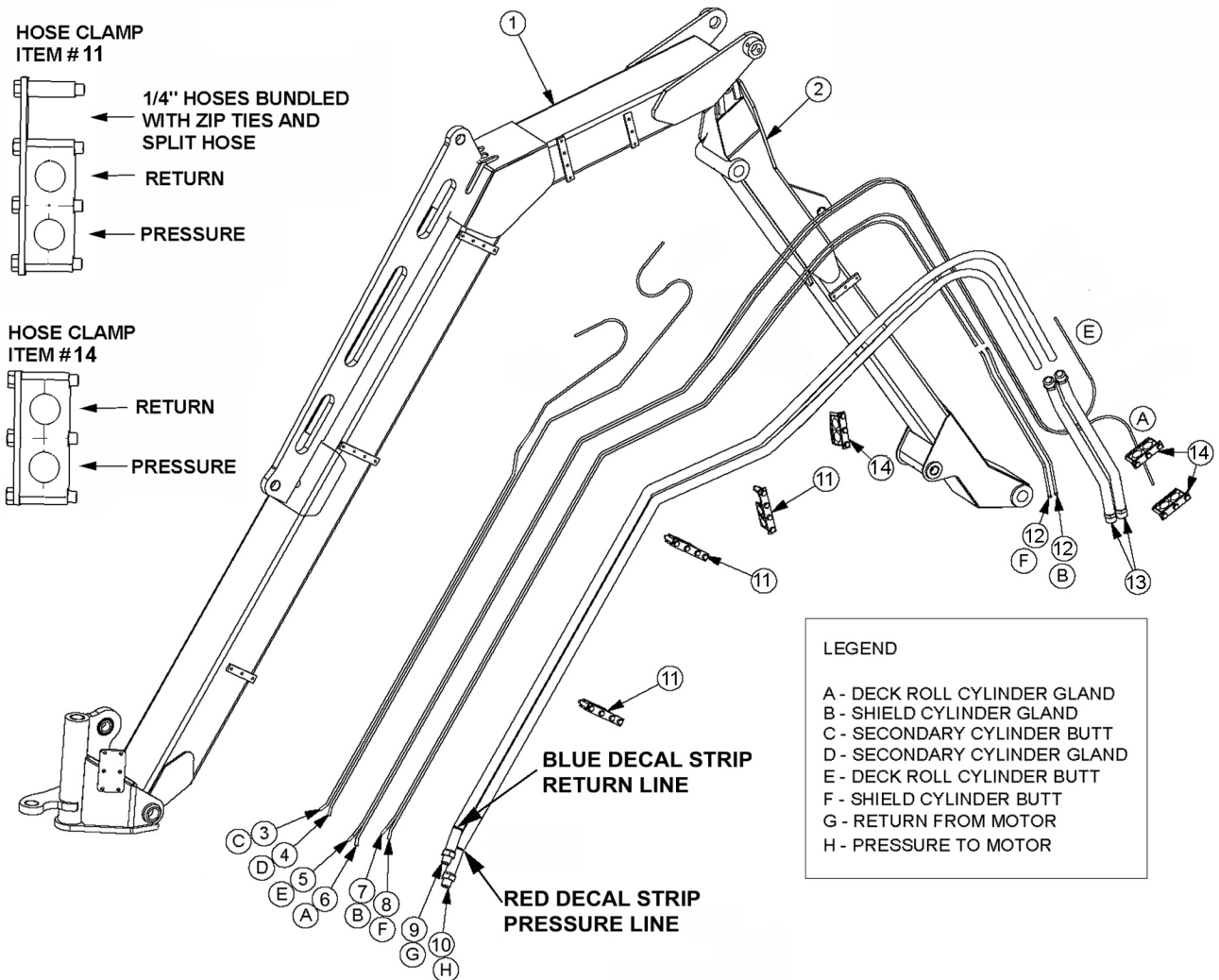

BOOM ASSY HYD BENGAL 24 T4

Continued...

| ITEM | PART NO. | QTY. | DESCRIPTION |
|------|----------|------|--|
| 1 | ----- | - | MAIN BOOM *REFER TO BOOM ARM ASSY |
| 2 | ----- | - | SECONDARY BOOM *REFER TO BOOM ARM ASSY |
| 3 | 06500716 | 1 | HOSE, 1/4" X 100" |
| 4 | --- | 1 | HOSE, 1/4" X 100 " |
| 5 | 06500717 | 1 | HOSE, 1/4" X 170" |
| 6 | ---- | 1 | HOSE, 1/4" X 170" |
| 7 | 06500718 | 1 | HOSE, 1/4" X 130" |
| 8 | --- | 1 | HOSE, 1/4" X 130" |
| 9 | 06500715 | 1 | HOSE, 1" X 198" |
| 10 | --- | 1 | HOSE, 1" X 198" |
| 11 | 06505019 | 3 | CLAMP KIT,3 SECTION |
| 12 | 34103 | 2 | TUBE,PRFRMD,SEC BOOM |
| 13 | 30169 | 2 | TUBE,PRFRMD,SEC BOOM,HP |
| 14 | 30111 | 2 | CLAMP KIT,2 SECTION |

COMMON BENGAL T4

BOOMREST - OPEN STOW

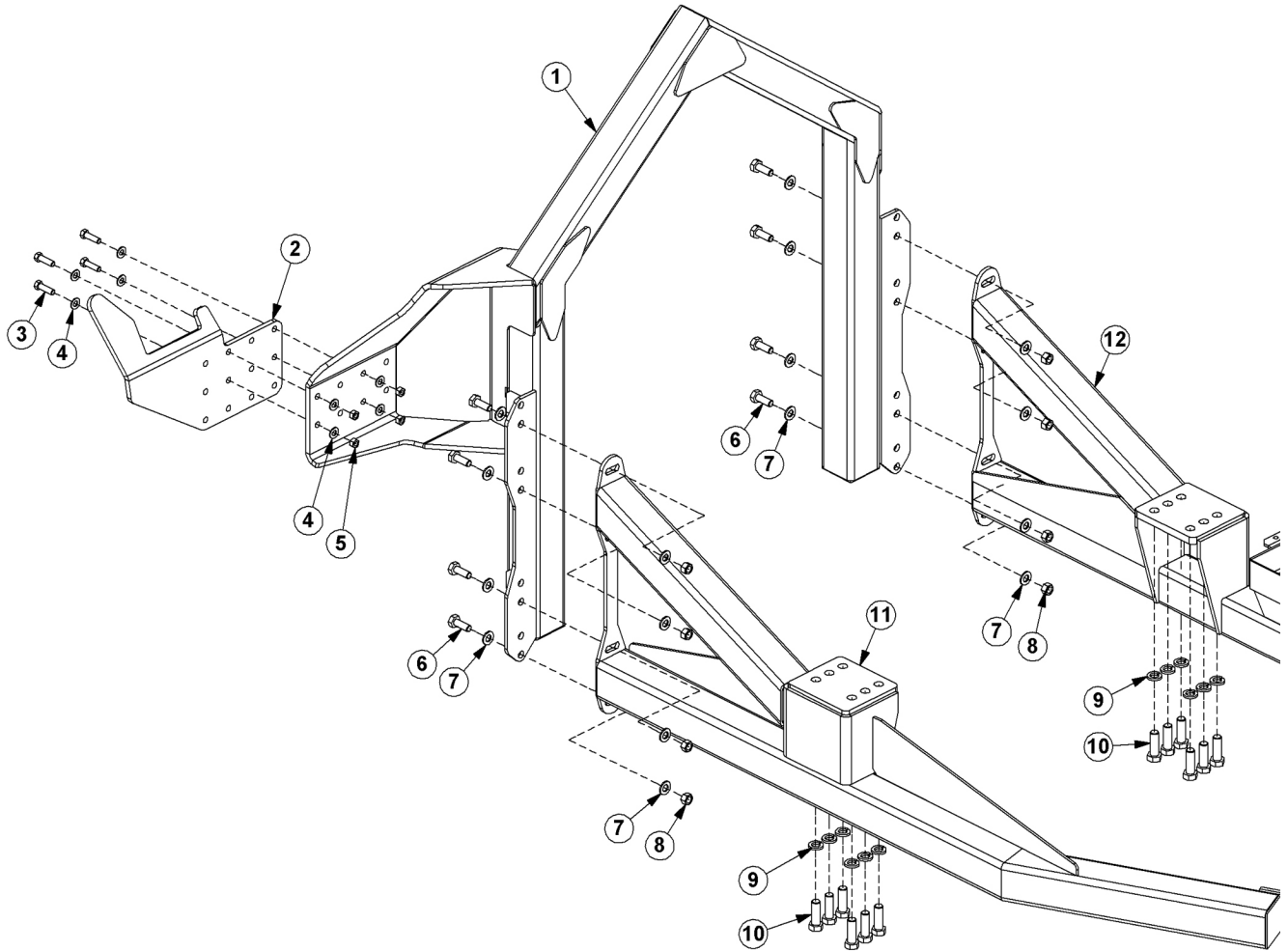

BOOMREST - OPEN STOW

Continued...

| ITEM | PART NO. | QTY. | DESCRIPTION |
|------|----------|------|---------------------------|
| 1 | 06310157 | 1 | BOOMREST,OS |
| 2 | 06410968 | 1 | SADDLE |
| 3 | 21732 | 4 | CAPSCREW,1/2" X 1-3/4",NC |
| 4 | 06533004 | 8 | FLATWASHER,1/2",SAE |
| 5 | 21725 | 4 | HEX NUT,1/2",NC |
| 6 | 21782 | 8 | CAPSCREW,5/8" X 1-3/4",NC |
| 7 | 33764 | 16 | FLATWASHER,5/8",SAE |
| 8 | 21775 | 8 | HEX NUT,5/8",NC |
| 9 | 24881 | 12 | LOCKWASHER,20MM |
| 10 | 27281 | 12 | CAPSCREW,20MM X 60MM,2.5P |
| 11 | --- | 1 | AXLE BRACE,RH |
| 12 | ---- | 1 | AXLE BRACE,LH |

COMMON BENGAL T4

50IN ROTARY MOWER ASSEMBLY

LINK TO THE SHIELD (OPTIONAL)

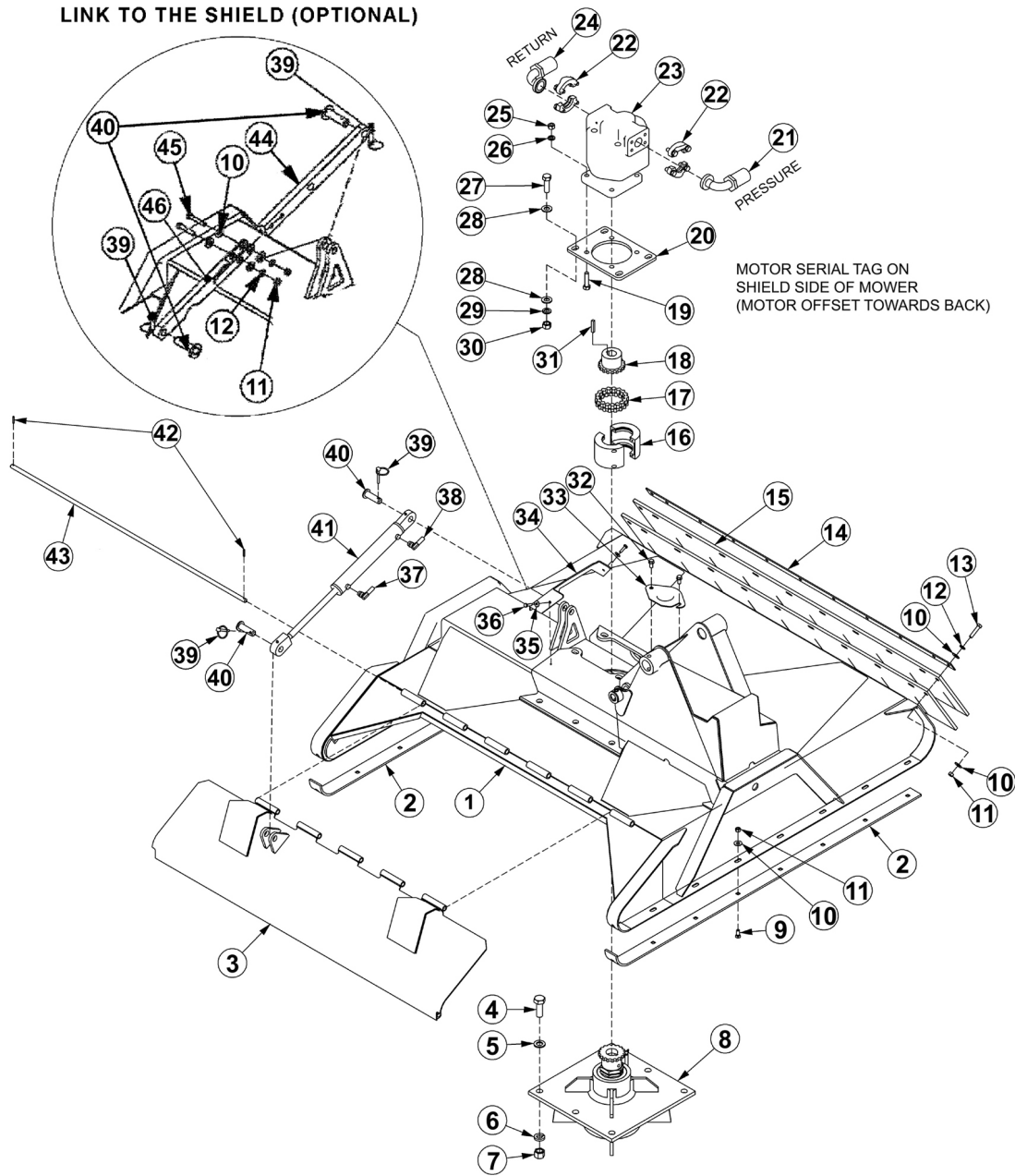

| ITEM | PART NO. | QTY. | DESCRIPTION |
|------|----------|------|--------------------------------|
| 1 | 33780 | 1 | DECK,WLDMNT,50" RTRY |
| 2 | 33777 | 2 | SKID SHOE,50" RTRY |
| 3 | 33754 | 1 | SHIELD,50"RTRY |
| 4 | 33879 | 6 | CAPSCREW, 3/4 X 2 1/4,NF GR 8 |
| 5 | 33880 | 6 | FLATWASHER,3/4",GR 8,SAE |
| 6 | 21993 | 6 | LOCKWASHER,3/4",GR 8 |
| 7 | 6T2413 | 6 | HEX NUT,3/4,NF,GR 8 |
| 8 | 6T1024H5 | 1 | SPINDLE ASSY,CPLT,HD,5/8 HOLES |

50IN ROTARY MOWER ASSEMBLY

Continued...

| ITEM | PART NO. | QTY. | DESCRIPTION |
|-------------|-----------------|-------------|-------------------------------|
| 9 | 6T2270 | 16 | PLOW BOLT,3/8" X 1" NC |
| 10 | 22016 | 33 | FLATWASHER,3/8" |
| 11 | 21625 | 20 | HEX NUT,3/8",NC |
| 12 | 21988 | 11 | LOCKWASHER, 3/8" |
| 13 | 21633 | 11 | CAPSCREW, 3/8 X 1 3/4,NC |
| 14 | 33774 | 1 | FLAP RETAINER,50" RTRY |
| 15 | 33775 | 2 | FLAP,50" RTRY |
| 16 | 6T1033 | 1 | COUPLER COVER |
| 17 | 6T1029 | 1 | COUPLER CHAIN |
| 18 | 21223 | 1 | SPROCKET |
| 19 | 21733 | 4 | CAPSCREW, 1/2 X 2,NC |
| 20 | 33776 | 1 | MOTOR MOUNT,PLATE,50" RTRY |
| 21 | 24490 | 1 | HOSE - PRESSURE |
| --- | 06500155 | 1 | HOSE- PRESSURE (LRS ONLY) |
| 22 | TF4852 | 2 | FLANGE KIT - #20 |
| 23 | 06504012 | 1 | MOTOR |
| 24 | 24489 | 1 | HOSE - RETURN |
| --- | 06500154 | 1 | HOSE-RETURN (LRS ONLY) |
| 25 | 21725 | 4 | HEX NUT, 1/2" NC |
| 26 | 06533004 | 4 | FLATWASHER, 1/2" |
| 27 | 6T2290 | 4 | CAPSCREW,5/8X2,NF GR 8 |
| 28 | 33764 | 8 | FLATWASHER,5/8",GR 8,SAE |
| 29 | 21992 | 4 | LOCKWASHER, 5/8 |
| 30 | 6T2408 | 4 | HEX NUT, 5/8, NF |
| 31 | TF1124 | 1 | SQUARE KEY |
| 32 | 33881 | 2 | CAPSCREW,FLG, 3/8 X 3/4,NC |
| 33 | 33779 | 1 | PLATE,COVER,KNF HOLE |
| 34 | 06410439 | 1 | COVER |
| 35 | 22014 | 2 | FLATWASHER,1/4 |
| 36 | 21530 | 2 | CAPSCREW,1/4 X 1,NC |
| 37 | 34187 | 1 | HOSE 1/4" X 75" |
| 38 | 34186 | 1 | HOSE 1/4" X 66" |
| 39 | RD1032 | 2 | LYNCH PIN |
| 40 | 33984 | 2 | PIN,SHIELD,50" |
| 41 | 33785 | 1 | 1-1/2" X 8", CYLINDER, WELDED |
| 42 | 6T3017 | 2 | ROLLPIN |
| 43 | 33778 | 1 | HINGE PIN,50" RTRY |
| 44 | 33772 | 1 | LINK, SHIELD 50" RTRY |
| 45 | 21634 | 2 | CAPSCREW, 3/8" X 2, NC |
| 46 | 33773 | 1 | LINK 2, SHIELD 50" RTRY |

COMMON BENGAL T4

50IN ROTARY KNIVES AND DISH

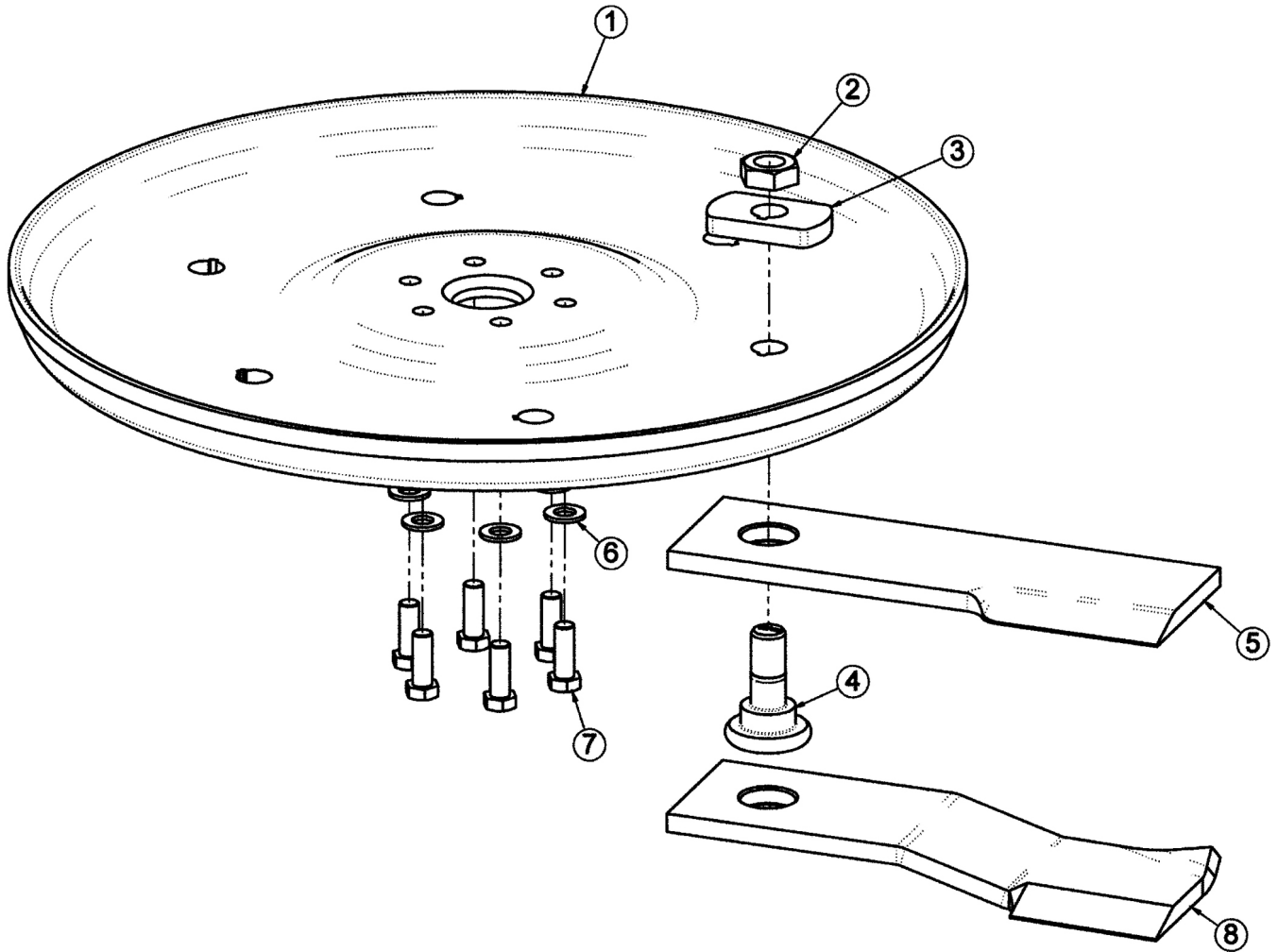

| ITEM | PART NO. | QTY. | DESCRIPTION |
|-------|----------|------|--|
| ----- | 06700089 | - | KIT,TRB50,DISK,W/BOLT KIT (INCLUDES ITEMS 1,3 & 7) |
| 1 | 06770003 | 1 | BLADE MOUNTING DISK |
| 2 | 6T1023R | 2 | NYLOCK HEX NUT 1 1/8" |
| 3 | 34878 | 2 | SPACER |
| 4 | 06538000 | 2 | KNIFE MOUNTING BOLT |
| 5 | 06521001 | 2 | STANDARD KNIFE |
| 6 | 33764 | 6 | FLATWASHER |
| 7 | 6T2259 | 6 | CAPSCREW |
| ----- | 06770012 | - | BOLT KIT (INCLUDES ITEMS 6, 7 & LOCTITE) |
| 8 | 06521002 | 2 | GRASS KNIFE (OPTIONAL) |
| ----- | 6T1825 | - | LOCTITE - USED ON ALL DISK MOUNTING BOLTS |

50IN ROTARY BLADE BAR AND KNIVES

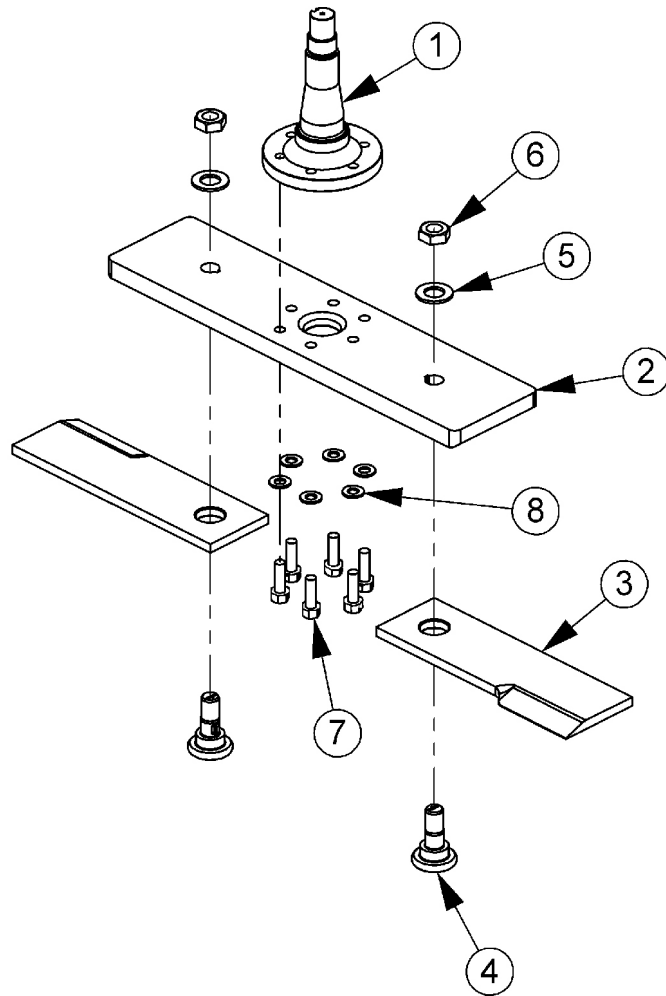

| ITEM | PART NO. | QTY. | DESCRIPTION |
|------|----------|------|-----------------------------|
| 1 | PT1018H5 | 1 | SPINDLE,5/8HOLES,HD,WO/TABS |
| 2 | 06400388 | 1 | BAR,BLADE,TRB |
| 3 | 06521001 | 2 | KNIFE,TRB50,5/8 |
| 4 | 06538000 | 2 | KNIFE MTG BOLT,5/8 SHOULDER |
| 5 | 06533002 | 2 | FLATWASHER,1 1/8,GR 8 |
| 6 | 6T1023R | 2 | KNIFE MTG NUT,1 1/8,NF,GR8 |
| 7 | 6T2259 | 6 | CAPSCREW,5/8X1-3/4,NF,GR8 |
| 8 | 33764 | 6 | FLATWASHER,5/8,GR 8,SAE |

60IN ROTARY MOWER ASSEMBLY

LINK TO THE SHIELD (OPTIONAL)

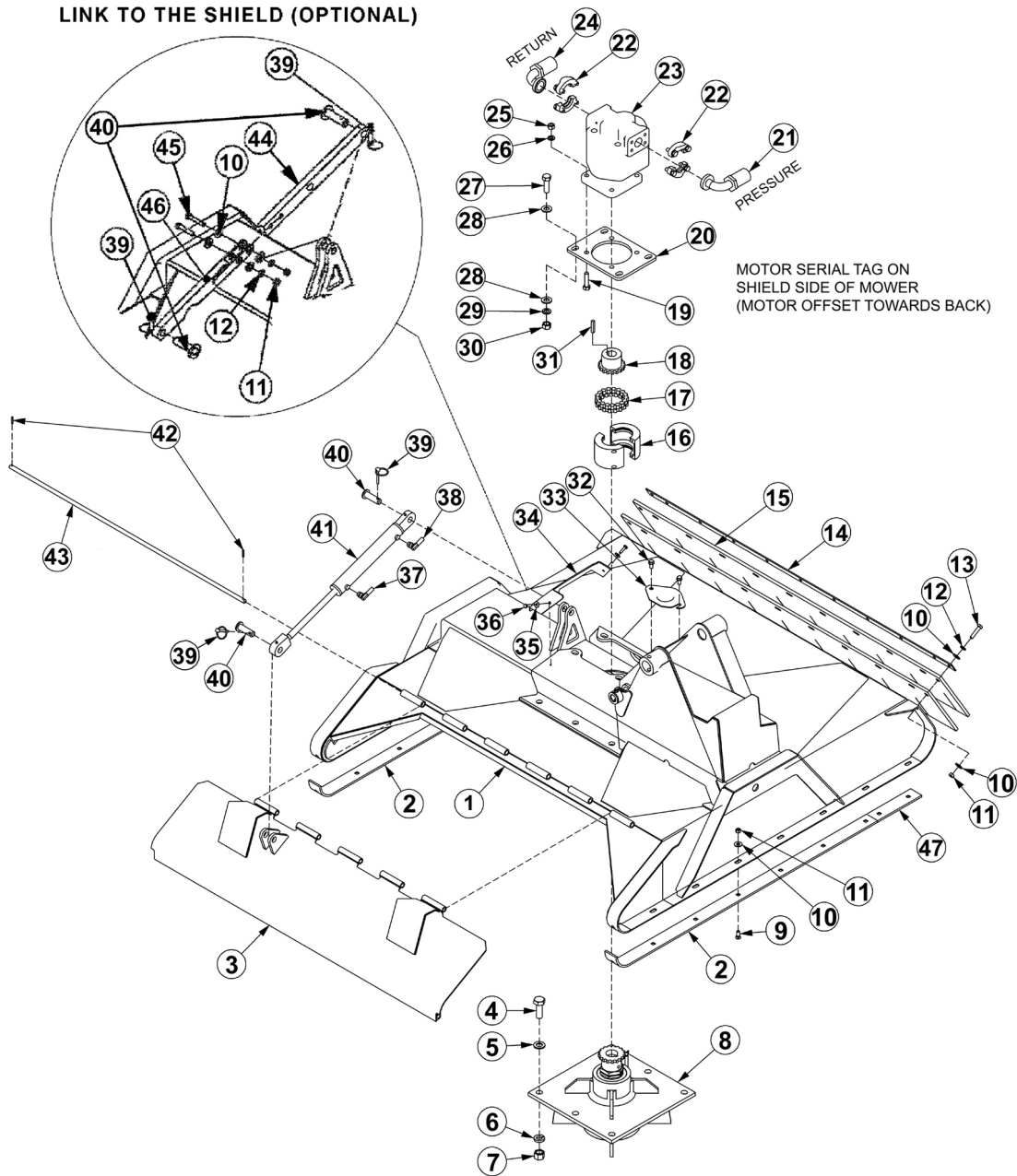

| ITEM | PART NO. | QTY. | DESCRIPTION |
|------|----------|------|--------------------------------|
| 1 | 06320159 | 1 | DECK,WLDMNT,60" RTRY |
| 2 | 33777 | 2 | SKID SHOE,RTRY |
| 3 | 06320162 | 1 | SHIELD,60"RTRY |
| 4 | 33879 | 6 | CAPSCREW, 3/4 X 2 1/4,NF GR 8 |
| 5 | 33880 | 6 | FLATWASHER,3/4",GR 8,SAE |
| 6 | 21993 | 6 | LOCKWASHER,3/4",GR 8 |
| 7 | 6T2413 | 6 | HEX NUT,3/4,NF,GR 8 |
| 8 | 6T1024H5 | 1 | SPINDLE ASSY,CPLT,HD,5/8 HOLES |

60IN ROTARY MOWER ASSEMBLY

Continued...

| ITEM | PART NO. | QTY. | DESCRIPTION |
|-------------|-----------------|-------------|-------------------------------|
| 9 | 6T2270 | 16 | PLOW BOLT,3/8" X 1" NC |
| 10 | 22016 | 33 | FLATWASHER,3/8" |
| 11 | 21625 | 20 | HEX NUT,3/8",NC |
| 12 | 21988 | 11 | LOCKWASHER, 3/8" |
| 13 | 21633 | 11 | CAPSCREW, 3/8 X 1 3/4,NC |
| 14 | 6T0823 | 1 | FLAP RETAINER,60" RTRY |
| 15 | 06520238 | 2 | FLAP,60" RTRY |
| 16 | 6T1033 | 1 | COUPLER COVER |
| 17 | 6T1029 | 1 | COUPLER CHAIN |
| 18 | 21223 | 1 | SPROCKET |
| 19 | 21733 | 4 | CAPSCREW, 1/2 X 2,NC |
| 20 | 33776 | 1 | MOTOR MOUNT,PLATE,RTRY |
| 21 | 24490 | 1 | HOSE - PRESSURE |
| --- | 06500155 | 1 | HOSE-PRESSURE (LRS ONLY) |
| 22 | TF4852 | 2 | FLANGE KIT - #20 |
| 23 | 6504011 | 1 | MOTOR |
| 24 | 24489 | 1 | HOSE - RETURN |
| --- | 06500154 | 1 | HOSE-RETURN (LRS ONLY) |
| 25 | 21725 | 4 | HEX NUT, 1/2" NC |
| 26 | 06533004 | 4 | FLATWASHER, 1/2" |
| 27 | 6T2290 | 4 | CAPSCREW,5/8X2,NF GR 8 |
| 28 | 33764 | 8 | FLATWASHER,5/8",GR 8,SAE |
| 29 | 21992 | 4 | LOCKWASHER, 5/8 |
| 30 | 6T2408 | 4 | HEX NUT, 5/8, NF |
| 31 | TF1124 | 1 | SQUARE KEY |
| 32 | 33881 | 2 | CAPSCREW,FLG, 3/8 X 3/4,NC |
| 33 | 33779 | 1 | PLATE,COVER,KNF HOLE |
| 34 | 06410439 | 1 | COVER |
| 35 | 22014 | 2 | FLATWASHER,1/4 |
| 36 | 21530 | 2 | CAPSCREW,1/4 X 1,NC |
| 37 | 34187 | 1 | HOSE 1/4" X 75" |
| 38 | 34186 | 1 | HOSE 1/4" X 66" |
| 39 | RD1032 | 2 | LYNCH PIN |
| 40 | 33984 | 2 | PIN,SHIELD |
| 41 | 33785 | 1 | 1-1/2" X 8", CYLINDER, WELDED |
| 42 | 6T3017 | 2 | ROLLPIN |
| 43 | 06420139 | 1 | HINGE PIN,60" RTRY |
| 44 | 33772 | 1 | LINK, SHIELD,RTRY |
| 45 | 21634 | 2 | CAPSCREW, 3/8" X 2, NC |
| 46 | 33773 | 1 | LINK 2, SHIELD,RTRY |
| 47 | 06401245 | 2 | SKID SHOE,TRB60 |

COMMON BENGAL T4

60IN ROTARY KNIVES AND DISH

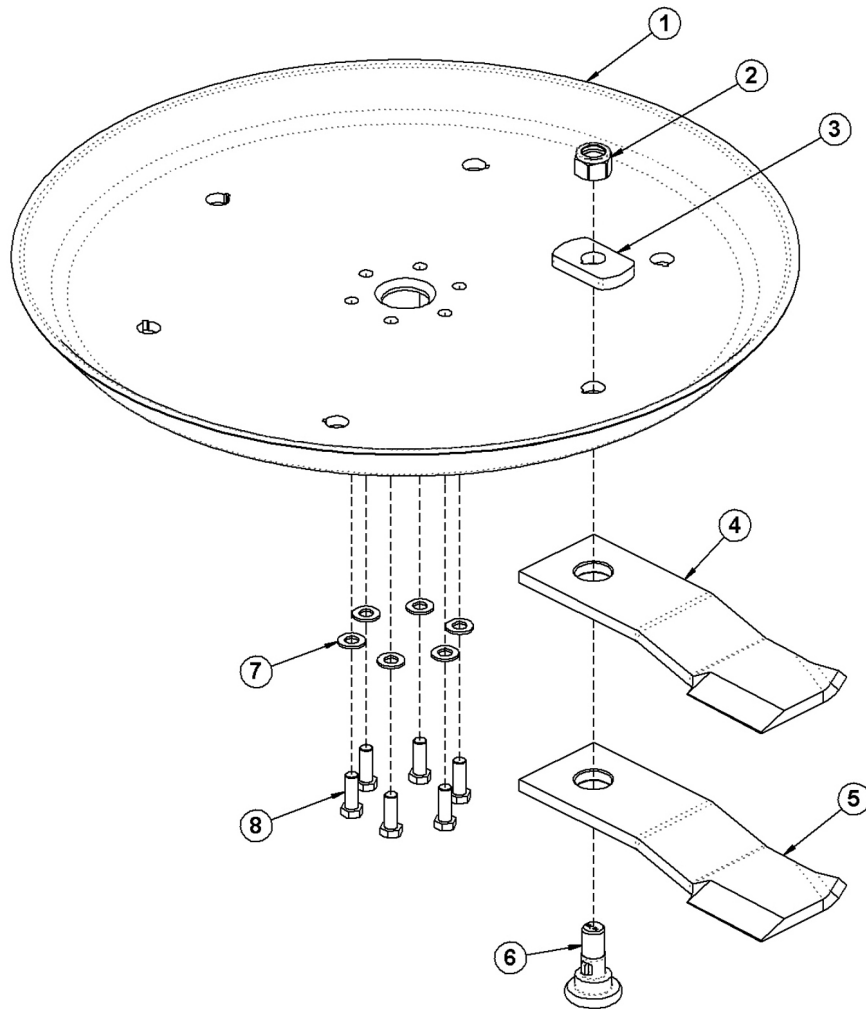

| ITEM | PART NO. | QTY. | DESCRIPTION |
|------|----------|------|-------------------------------------|
| 1 | 34876 | 1 | BLADE MOUNTING DISH,60" |
| 2 | 6T1023R | 2 | NYLOCK NUT,1-1/8",NF |
| 3 | 34878 | 2 | SPACER |
| 4 | 34684 | 2 | STANDARD GRASS KNIFE |
| 5 | 34685 | 2 | HIGH SUCTION GRASS KNIFE (OPTIONAL) |
| 6 | 34497 | 2 | KNIFE MOUNTING BOLT |
| 7 | 25270 | 6 | FLATWASHER,5/8",GR8,USS |
| 8 | 6T2259 | 6 | CAPSCREW,5/8" X 1-3/4",NF,GR8 |
| --- | 6T1825 | 1 | LOCTITE (USED ON ITEM 8) |
| --- | 27167 | 1 | BOLT KIT (ITEMS 7 & 8) |
| --- | 33893 | 1 | KNIFE KIT (ITEMS 2,4 & 6) |

60IN ROTARY BLADE BAR AND KNIVES

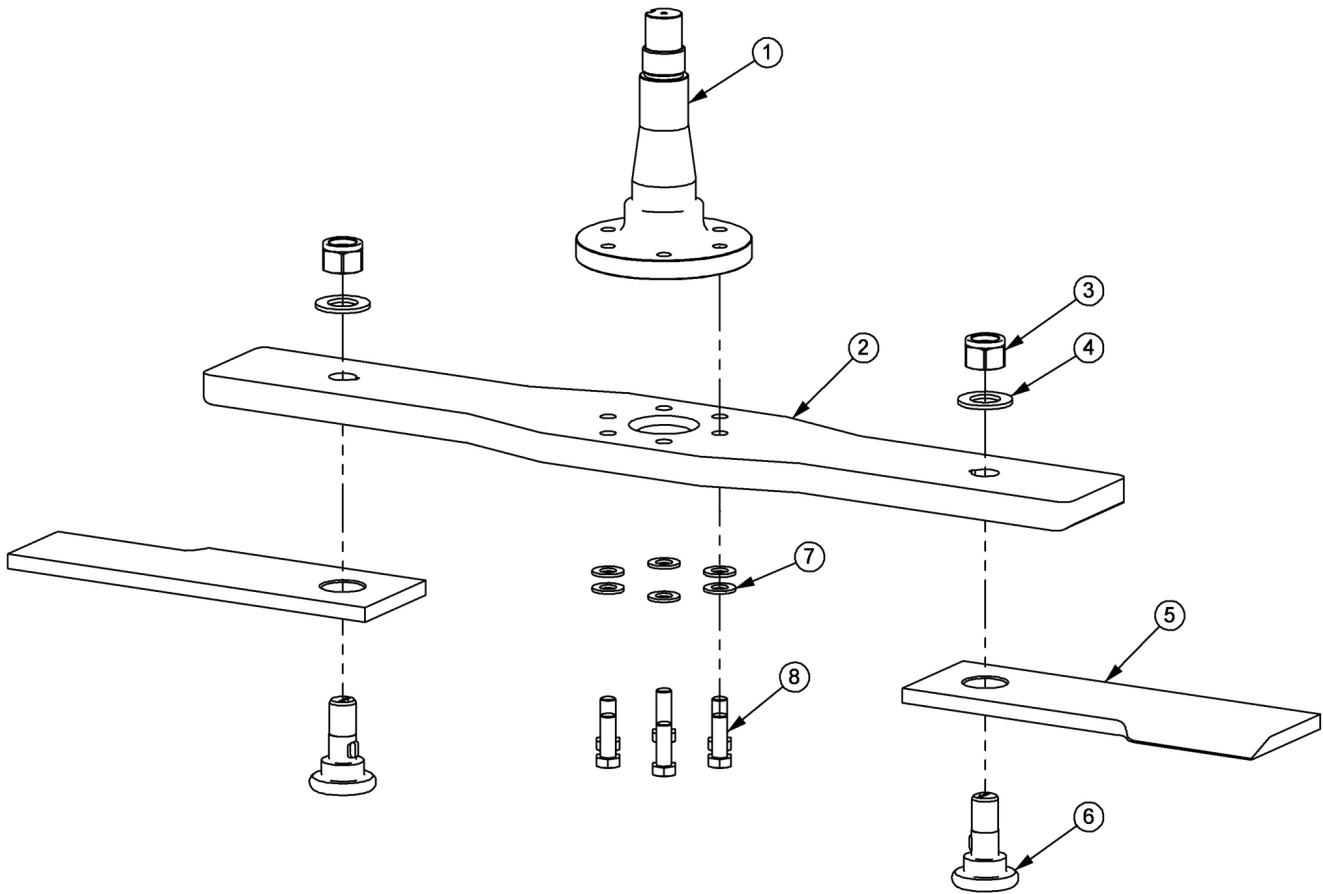

| ITEM | PART NO. | QTY. | DESCRIPTION |
|------|----------|------|-------------------------------|
| 1 | PT1018H5 | 1 | SPINDLE |
| 2 | 06400690 | 1 | BAR,BLADE,RTRY60 |
| 3 | 6T1023R | 2 | KNIFE MTG NUT,1-1/8,NYLOCK,NF |
| 4 | 06533002 | 2 | FLATWASHER,1-1/8,GR8 |
| 5 | 06521001 | 2 | KNIFE,TRB50,5/8 |
| 6 | 06538000 | 2 | KNIFE MTG BOLT,5/8 SHOULDER |
| 7 | 33764 | 6 | FLATWASHER,5/8,GR 8,SAE |
| 8 | 6T2259 | 6 | CAPSCREW,5/8 X 1-3/4,NF,GR8 |

ROTARY MOWER SPINDLE ASSEMBLY

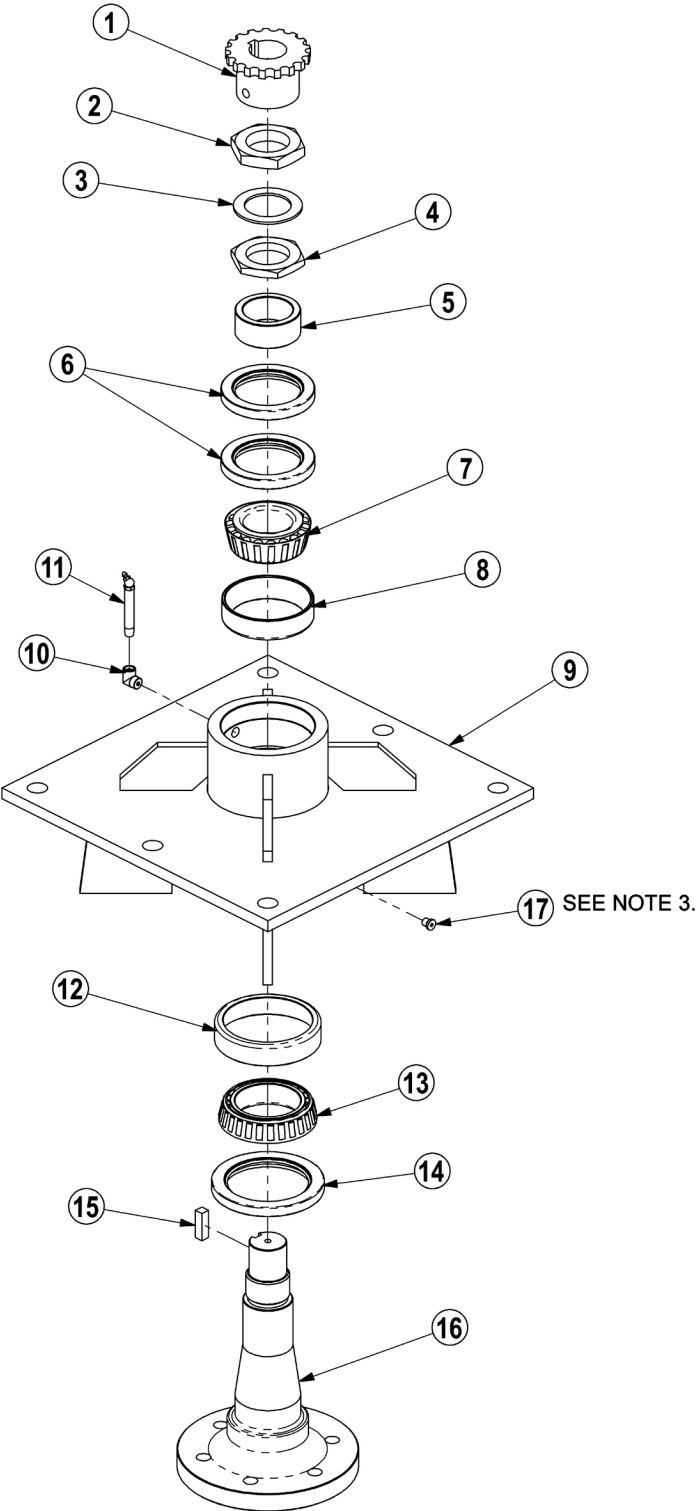

NOTES:

- 1. FREEPLAY: .001" - .003"
- 2. GREASE: FILL WITH MOBILITH SHC 220.
- 3. APPLY LOCTITE "271" TO O-RING PLUG THRDS.

ROTARY MOWER SPINDLE ASSEMBLY

Continued...

| ITEM | PART NO. | QTY. | DESCRIPTION |
|-------|----------|------|--|
| ----- | 6T1024H5 | - | SPINDLE ASSEMBLY COMPLETE |
| 1 | 6T1031 | 1 | SPROCKET |
| 2 | 6T1016 | 1 | BEARING LOCK NUT - THICK |
| 3 | 22596 | 1 | JAM WASHER |
| 4 | 6T1015 | 1 | BEARING ADJUSTMENT NUT - THIN |
| 5 | 6T1014 | 1 | BEARING ADJUSTMENT SLEEVE |
| 6 | 6T1011 | 1 | UPPER SEAL - SET OF 2 |
| 7 | 6T1012 | 1 | BEARING CONE |
| 8 | 6T1013 | 1 | BEARING CUP |
| 9 | 6T1010H | 1 | SPINDLE HOUSING |
| 10 | 30570 | 1 | FITTING STREET ELBOW |
| 11 | 33990 | 1 | GREASE ZERK |
| 12 | 6T1013H | 1 | BEARING CUP |
| 13 | 6T1012H | 1 | BEARING CONE |
| 14 | 6T1011H | 1 | LOWER SEAL |
| 15 | 6T1019 | 1 | SPINDLE KEY |
| 16 | PT1018H5 | 1 | SPINDLE |
| 17 | 06503064 | 1 | O-RING PLUG, 1/8" |
| ----- | 31771 | - | SPINDLE REBUILD KIT (INCLUDES ITEMS 2 - 8 AND 12 - 15) |

BOOM ROTARY PIVOT ASSEMBLY

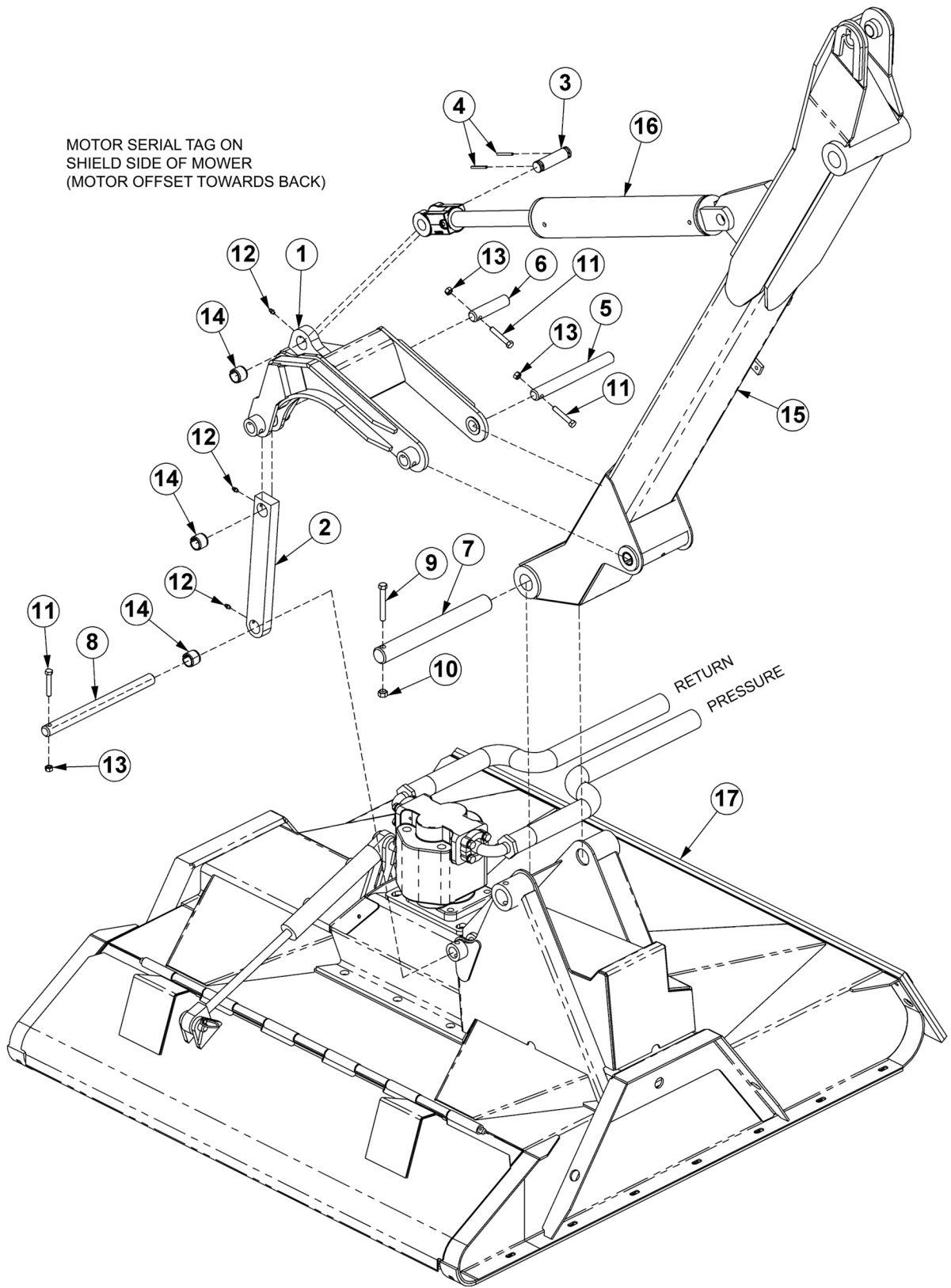

BOOM ROTARY PIVOT ASSEMBLY

Continued...

| ITEM | PART NO. | QTY. | DESCRIPTION |
|------|----------|------|---|
| 1 | TB1032 | 1 | ROTARY PIVOT ASSY |
| 2 | TB1028 | 1 | PIVOT ARM ASSY |
| 3 | TB1033 | 1 | PIN,CLEVIS |
| 4 | 06537021 | 2 | ROLL PIN |
| 5 | TF3097 | 1 | PIN |
| 6 | TB1030 | 1 | PIN |
| 7 | 33985 | 1 | PIN |
| 8 | 33986 | 1 | PIN |
| 9 | 21688 | 1 | CAPSCREW,7/16 X 3-1/4,NC |
| 10 | 21677 | 1 | NYLOCK NUT,7/16 NC |
| 11 | 21635 | 3 | CAPSCREW,3/8 X 2-1/4 |
| 12 | 6T3207 | 3 | GREASE ZERK |
| 13 | 21627 | 3 | NYLOCK NUT,3/8,NC |
| 14 | TB3010 | 3 | BUSHING |
| 15 | ----- | - | SECONDARY BOOM *REFER TO BOOM ARM ASSY |
| 16 | ----- | - | CYLINDER *REFER TO BOOM ARM ASSY |
| 17 | ----- | - | ROTARY MOWER HEAD *REFER TO ROTARY DECK |

50IN FLAIL DRIVE ASSEMBLY

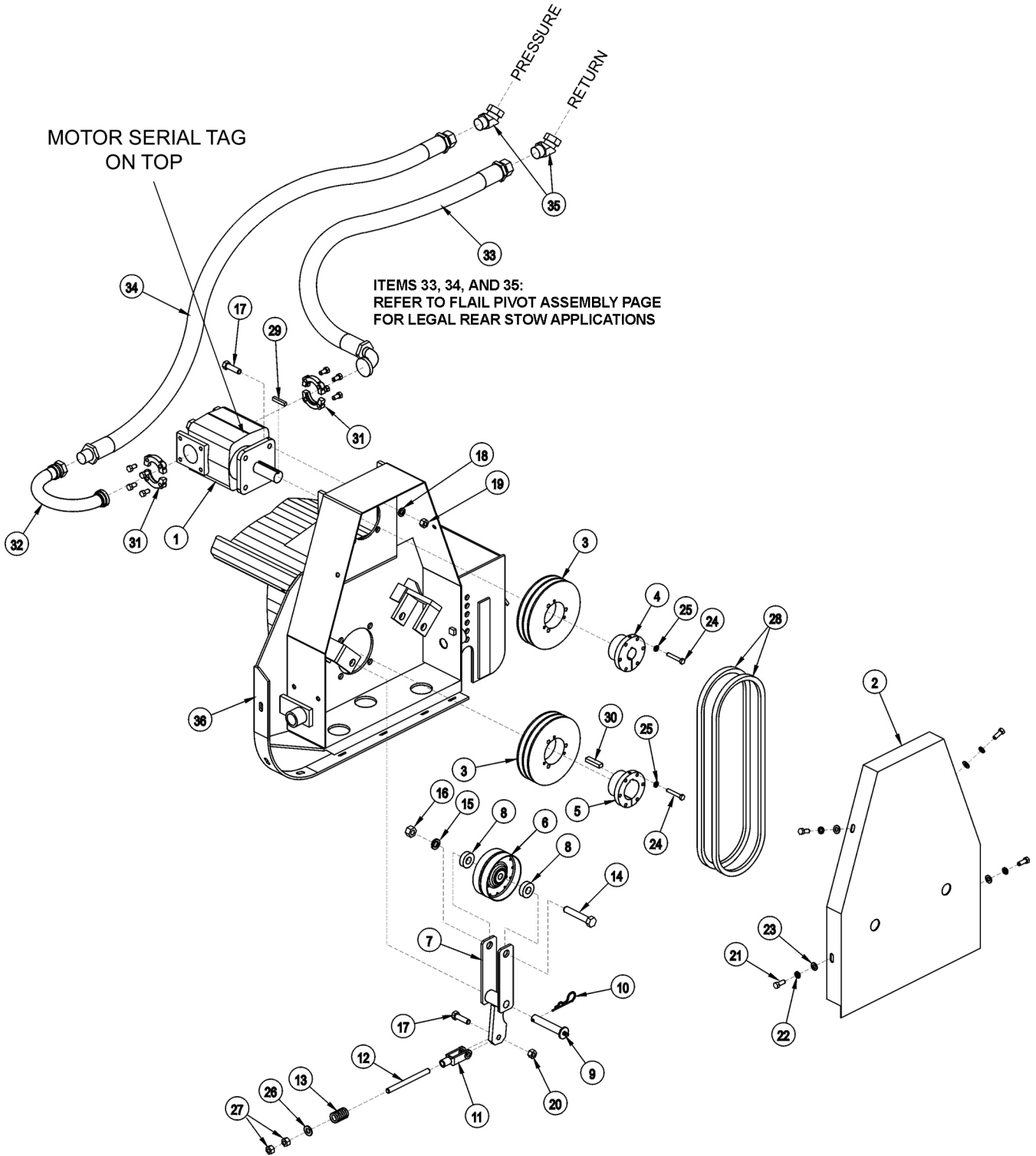

50IN FLAIL DRIVE ASSEMBLY

Continued...

| ITEM | PART NO. | QTY. | DESCRIPTION |
|------|----------|------|--|
| 1 | 06504132 | 1 | MOTOR (M350-1 3/4" GEAR) |
| 2 | TF3006 | 1 | BELT GUARD |
| 3 | TF3043 | 2 | SHEAVE |
| 4 | TF3013 | 1 | BUSHING |
| 5 | TF3011 | 1 | BUSHING |
| 6 | TF3034 | 1 | IDLER PULLEY |
| 7 | TF3205 | 1 | IDLER ARM |
| 8 | TF3206 | 2 | IDLER PULLEY SPACER |
| 9 | TF3605 | 1 | IDLER ARM PIN WITH ZERK |
| 10 | 6T3004 | 1 | R - CLIP |
| 11 | PT3611A | 1 | CLEVIS |
| 12 | 32481 | 1 | THREADED ROD |
| 13 | TF3620 | 1 | COMPRESSION SPRING |
| 14 | 21789 | 1 | CAPSCREW 5/8" X 3 1/2" |
| 15 | 21992 | 1 | LOCKWASHER 5/8" |
| 16 | 21775 | 1 | HEX NUT 5/8" |
| 17 | 21732 | 5 | CAPSCREW 1/2" X 1 3/4" |
| 18 | 21990 | 4 | LOCKWASHER 1/2" |
| 19 | 21725 | 4 | HEX NUT 1/2" |
| 20 | 6T2418 | 1 | LOCK NUT 1/2" |
| 21 | 21630 | 4 | CAPSCREW 3/8" X 1" |
| 22 | 21988 | 4 | LOCKWASHER 3/8" |
| 23 | 22016 | 4 | FLATWASHER 3/8" |
| 24 | 21584 | 6 | CAPSCREW 5/16" X 2" |
| 25 | 21987 | 6 | LOCKWASHER 5/16" |
| 26 | 27938 | 1 | FLATWASHER 1/2" |
| 27 | 21700 | 2 | HEX NUT 1/2" NF |
| 28 | TF3021 | 2 | BELT |
| 29 | TF1125 | 1 | SQUARE KEY |
| 30 | TF1025 | 1 | SQUARE KEY MOTOR |
| 31 | TF4852 | 2 | FLANGE KIT |
| 32 | 34227 | 1 | PREFORMED TUBE |
| 33 | 31218 | 1 | HOSE - RETURN |
| 34 | 34331 | 1 | HOSE - PRESSURE |
| 35 | 24724 | 2 | SWIVEL FITTING |
| 36 | ----- | - | CUTTER HEAD *REFER TO CUTTER HEAD ASSY |

50IN FLAIL MOWER ASSEMBLY

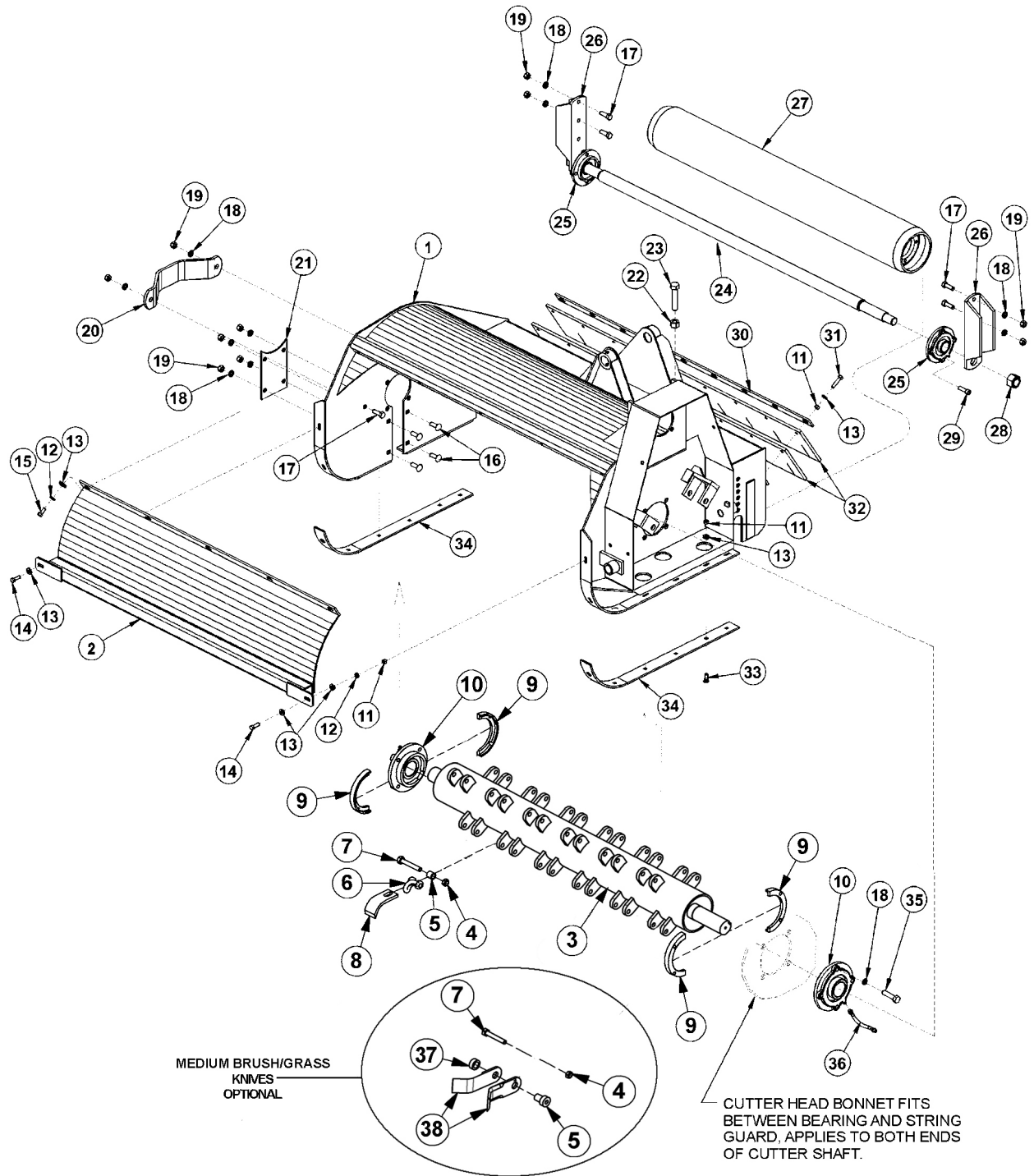

| ITEM | PART NO. | QTY. | DESCRIPTION |
|------|----------|------|---|
| --- | 34787 | 1 | FLAIL,BOOM,50,BRUSH,CPLT ASSY (LIGHT BRUSH/GRASS) |
| | 06742133 | 1 | FLAIL,BOOM,50,MD GRASS,CPLT ASSY (MEDIUM BRUSH/GRASS) |
| 1 | TF3003F | 1 | CUTTER HEAD BONNET |
| 2 | TF3004 | 1 | FRONT SHIELD |

50IN FLAIL MOWER ASSEMBLY

Continued...

| ITEM | PART NO. | QTY. | DESCRIPTION |
|------|----------|------|---------------------------------------|
| 3 | 34783 | 1 | TBF50 (LIGHT BRUSH/GRASS KNIFE ASSY) |
| ---- | 06700115 | 1 | TBF50 (MEDIUM BRUSH/GRASS KNIFE ASSY) |
| 4 | 6T2419 | 24 | HEX NUT,9/16",NC,STOVER |
| 5 | 06420182 | 24 | BUSHING |
| 6 | 34782 | 24 | CLEVIS (LIGHT BRUSH/GRASS KNIVES) |
| 7 | 34786 | 24 | CAPSCREW,9/16" X 3-1/2",NC |
| 8 | 34780 | 24 | KNIFE (LIGHT BRUSH/GRASS CUTTING) |
| 9 | 31204 | 2 | STRING GUARD SET (2 PIECES PER SET) |
| 10 | TF1018 | 2 | FLANGE BEARING,2-3/16" |
| 11 | 21625 | 23 | HEX NUT,3/8",NC |
| 12 | 21988 | 7 | LOCKWASHER,3/8" |
| 13 | 22016 | 30 | FLATWASHER,3/8" |
| 14 | 21631 | 2 | CAPSCREW,3/8" X 1-1/4",NC |
| 15 | 21630 | 5 | CAPSCREW,3/8" X 1",NC |
| 16 | 6T7031D | 4 | PLOW BOLT,1/2" X 1-1/2",NC |
| 17 | 21731 | 6 | CAPSCREW,1/2" X 1-1/2",NC |
| 18 | 21990 | 18 | LOCKWASHER,1/2" |
| 19 | 21725 | 10 | HEX NUT,1/2",NC |
| 20 | TF1040 | 1 | CUTTER SHAFT GUARD |
| 21 | TF3007A | 1 | COVER PLATE |
| 22 | 21825 | 1 | HEX NUT,5/8",NC |
| 23 | 21838 | 1 | CAPSCREW,3/4" X 3-1/2",NC |
| 24 | TF3406 | 1 | GROUND ROLLER TIE ROD |
| 25 | TF1022 | 2 | FLANGE BEARING,1-3/8" |
| 26 | TF3407 | 2 | GROUND ROLLER ADJUSTMENT BRACKET |
| 27 | TF3405 | 1 | GROUND ROLLER |
| 28 | 6T1023R | 2 | NYLOCK NUT,1-1/8",NF |
| 29 | 6T2330 | 8 | CAPSCREW,7/16" X 1-1/2",SOCKET HEAD |
| 30 | TB1008 | 1 | FLAP RETAINING BAR |
| 31 | 21633 | 9 | CAPSCREW,3/8" X 1-3/4",NC |
| 32 | TB1006A | 2 | DEFLECTOR FLAP |
| 33 | 6T2270 | 12 | PLOWBOLT,3/8" X 1",NC |
| 34 | TF3001 | 2 | SKID SHOE |
| 35 | 06530218 | 8 | CAPSCREW,1/2" X 1-3/4",NC |
| 36 | TF1032 | 1 | FLANGE BEARING GREASE HOSE |
| 37 | 06420183 | 24 | SPACER (MEDIUM BRUSHGRASS KNIVES) |
| 38 | 06521007 | 48 | KNIFE (MEDIUM BRUSH/GRASS CUTTING) |

COMMON BENGAL T4

50IN FLAIL MOWER ASSY, PASS-THROUGH KNIVES

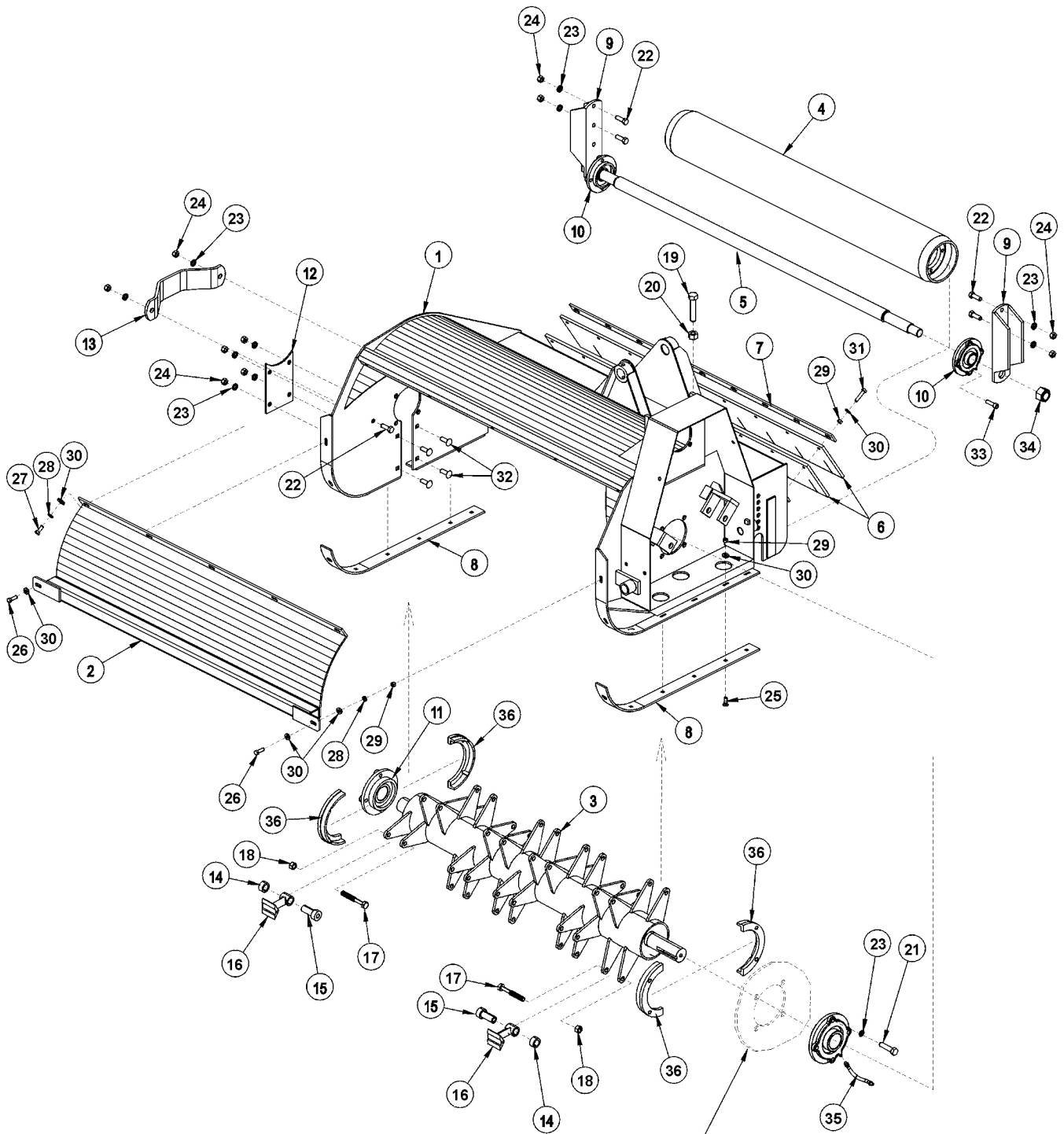

CUTTER HEAD BONNET FITS BETWEEN BEARING AND STRING GUARD, APPLIES TO BOTH ENDS OF CUTTER SHAFT.

50IN FLAIL MOWER ASSY, PASS-THROUGH KNIVES

Continued...

| ITEM | PART NO. | QTY. | DESCRIPTION |
|------|----------|------|-------------------------------------|
| --- | 34172 | 1 | FLAIL,BOOM,50,CPLT ASSY |
| 1 | TF3003F | 1 | CUTTER HEAD BONNET |
| 2 | TF3004 | 1 | FRONT SHIELD |
| 3 | 33717 | 1 | TBF50,CUTTERSHAFT,PASS THRU KNIVES |
| 4 | TF3405 | 1 | GROUND ROLLER |
| 5 | TF3406 | 1 | GROUND ROLLER TIE ROD |
| 6 | TB1006A | 2 | DEFLECTOR FLAP |
| 7 | TB1008 | 1 | FLAP RETAINING BAR |
| 8 | TF3001 | 2 | SKID SHOE |
| 9 | TF3407 | 2 | GROUND ROLLER ADJUSTMENT BRACKET |
| 10 | TF1022 | 2 | FLANGE BEARING,1-3/8" |
| 11 | TF1018 | 2 | FLANGE BEARING,2-3/16" |
| 12 | TF3007A | 1 | COVER PLATE |
| 13 | TF1040 | 1 | CUTTER SHAFT GUARD |
| 14 | 33858 | 24 | SPACER,COLLAR |
| 15 | 33857 | 24 | SHOULDER,BUSHING |
| 16 | 46399.01 | 24 | KNIFE,FLAIL,FORGED |
| 17 | 33854 | 24 | CAPSCREW,5/8" X 4-1/2",NC |
| 18 | 32674 | 24 | HEX NUT,5/8",NC |
| 19 | 21838 | 1 | CAPSCREW,3/4" X 3-1/2",NC |
| 20 | 21825 | 1 | HEX NUT,5/8",NC |
| 21 | 21732 | 8 | CAPSCREW,1/2" X 1-3/4",NC |
| 22 | 21731 | 6 | CAPSCREW,1/2" X 1-1/2",NC |
| 23 | 21990 | 18 | LOCKWASHER,1/2" |
| 24 | 21725 | 10 | HEX NUT,1/2",NC |
| 25 | 6T2270 | 12 | PLOWBOLT,3/8" X 1",NC |
| 26 | 21631 | 2 | CAPSCREW,3/8" X 1-1/4",NC |
| 27 | 21630 | 5 | CAPSCREW,3/8" X 1",NC |
| 28 | 21988 | 7 | LOCKWASHER,3/8" |
| 29 | 21625 | 23 | HEX NUT,3/8",NC |
| 30 | 22016 | 30 | FLATWASHER,3/8" |
| 31 | 21633 | 9 | CAPSCREW,3/8" X 1-3/4",NC |
| 32 | 6T7031D | 4 | PLOW BOLT,1/2" X 1-1/2",NC |
| 33 | 6T2330 | 8 | CAPSCREW,7/16" X 1-1/2",NC,SCKT HD |
| 34 | 6T1023R | 2 | NYLOCK NUT,1-1/8",NF |
| 35 | TF1032 | 1 | FLANGE BEARING GREASE HOSE |
| 36 | 31204 | 2 | STRING GUARD SET (2 PIECES PER SET) |

COMMON BENGAL T4

63IN FLAIL DRIVE ASSEMBLY

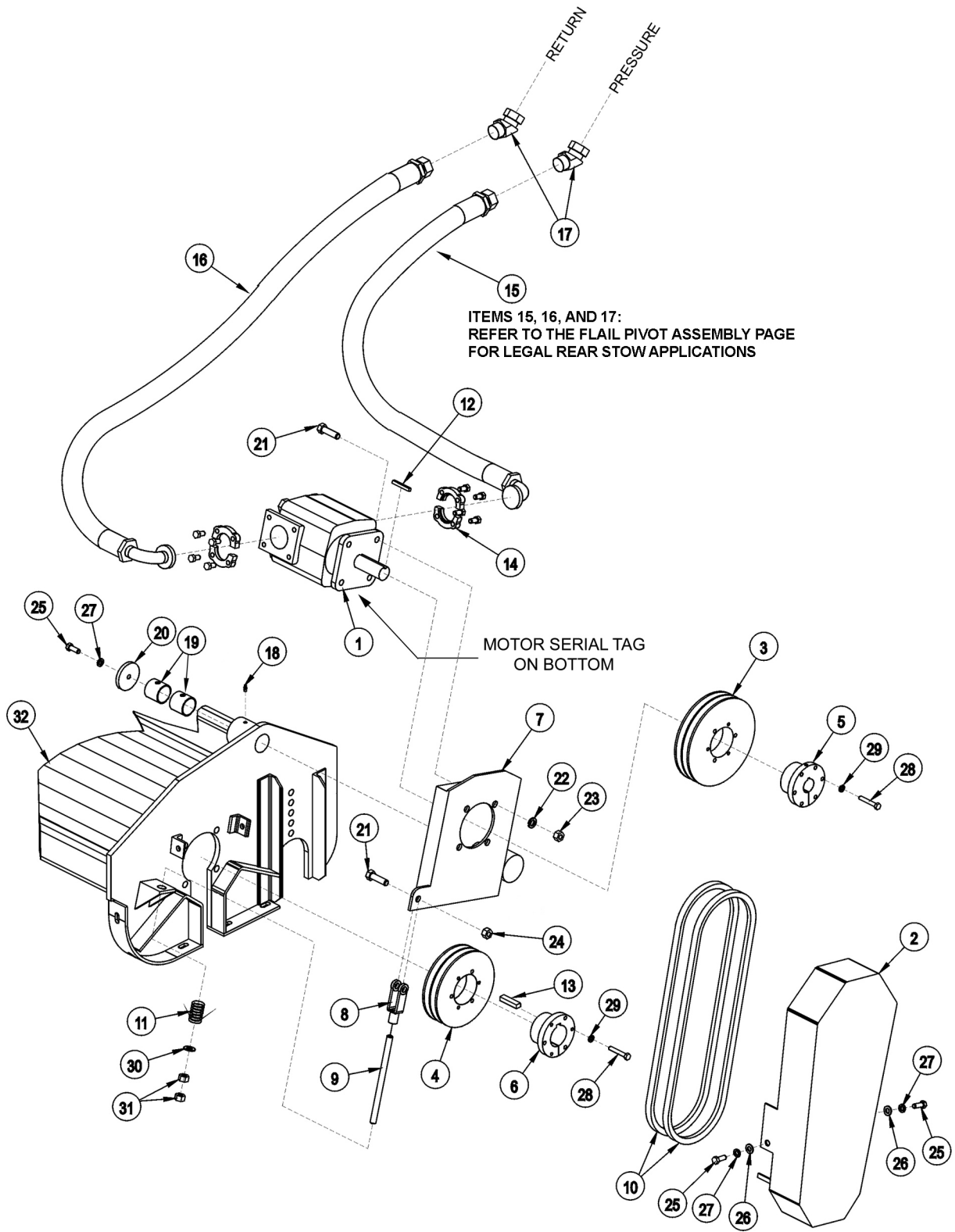

63IN FLAIL DRIVE ASSEMBLY

Continued...

| ITEM | PART NO. | QTY. | DESCRIPTION |
|------|----------|------|----------------------------------|
| 1 | 06504132 | 1 | MOTOR (M350-1 3/4 GEAR) |
| 2 | 32569 | 1 | BELT GUARD |
| 3 | TF3044 | 1 | UPPER SHEAVE |
| 4 | TF3040 | 1 | LOWER SHEAVE |
| 5 | TF3013 | 1 | BUSHING |
| 6 | 28723 | 1 | BUSHING |
| 7 | 28679B | 1 | MOTOR CHANNEL |
| 8 | PT3611A | 1 | CLEVIS |
| 9 | 40496 | 1 | THREADED ROD |
| 10 | 28702 | 2 | BELT |
| 11 | TF3620A | 1 | TENSIONER SPRING |
| 12 | 28572 | 1 | SQUARE KEY |
| 13 | 26142A | 1 | SQUARE KEY |
| 14 | TF4852 | 2 | FLANGE KIT |
| 15 | 30308 | 1 | HOSE,1 X 69 - PRESSURE |
| 16 | 30309 | 1 | HOSE,1 X 78 - RETURN |
| 17 | 24724 | 2 | SWIVEL FITTING |
| 18 | TF1033 | 1 | GREASE ZERK |
| 19 | 27580 | 2 | BUSHING |
| 20 | 28682 | 1 | MOTOR CHANNEL WASHER |
| 21 | 21732 | 5 | CAPSCREW 1/2" X 1 3/4" |
| 22 | 21990 | 4 | LOCKWASHER 1/2" |
| 23 | 21725 | 4 | HEX NUT 1/2" |
| 24 | 6T2418 | 1 | STOVER NUT 1/2" |
| 25 | 21630 | 3 | CAPSCREW 3/8" X 1" |
| 26 | 22016 | 2 | FLATWASHER 3/8" |
| 27 | 21988 | 3 | LOCKWASHER 3/8" |
| 28 | 21584 | 6 | CAPSCREW 5/16" X 2" |
| 29 | 21987 | 6 | LOCKWASHER 5/16" |
| 30 | 27938 | 1 | FLATWASHER 1/2" |
| 31 | 21700 | 2 | HEX NUT 1/2" NF |
| 32 | ----- | - | CUTTER HEAD *REFER TO MOWER ASSY |

63IN FLAIL MOWER ASSEMBLY

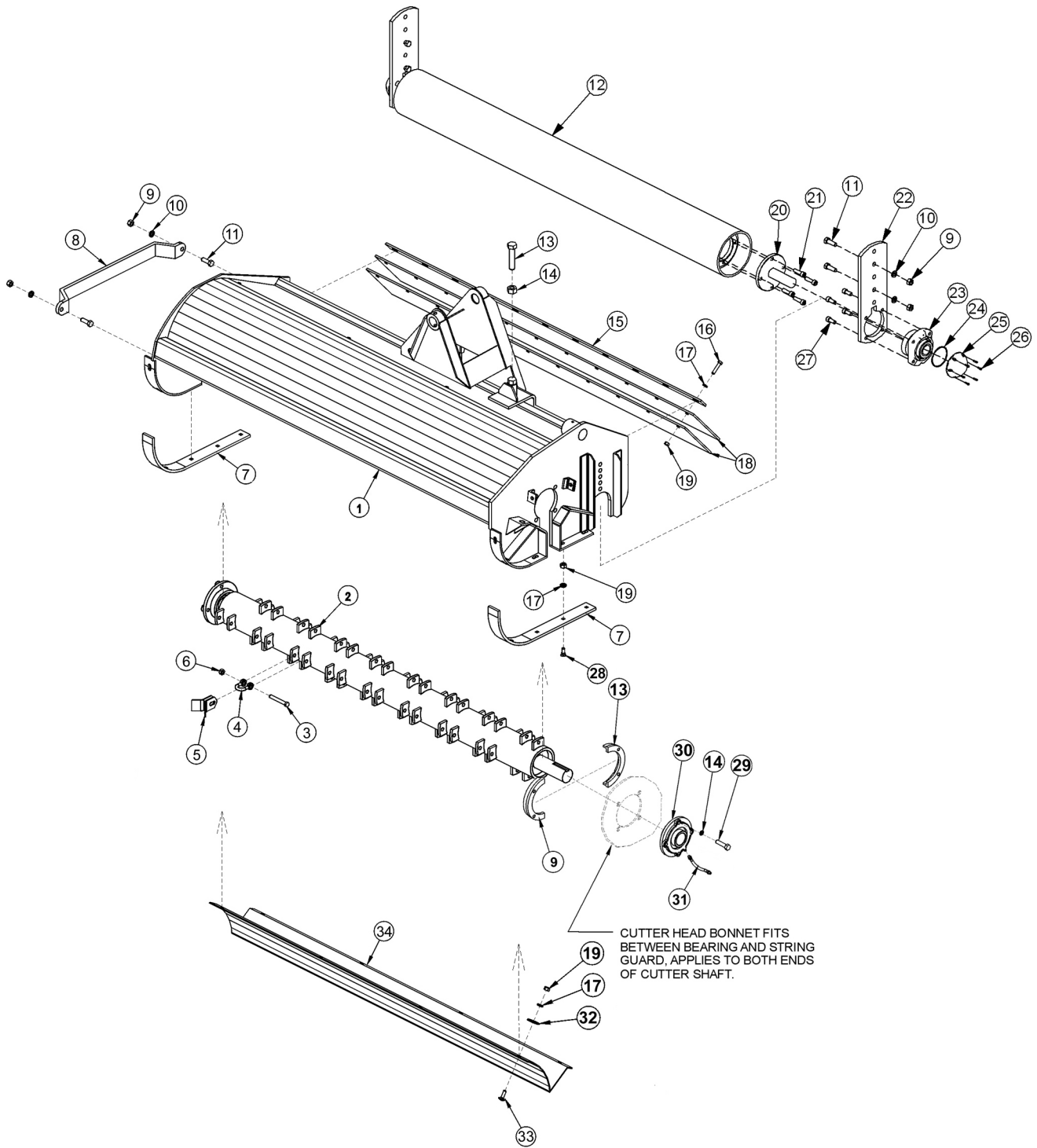

63IN FLAIL MOWER ASSEMBLY

Continued...

| ITEM | PART NO. | QTY. | DESCRIPTION |
|-------|----------|------|---|
| ----- | 06200271 | - | FLAIL,BOOM,63,GRASS,CPLT ASSY |
| 1 | 28659H | 1 | CUTTER HEAD BONNET |
| 2 | 28743 | - | CUTTER SHAFT / KNIFE ASSY STANDARD GRASS |
| ----- | 28642C | 1 | CUTTER SHAFT,63,STD |
| 3 | 34011 | 36 | FLAIL KNIFE MOUNTING BOLT |
| 4 | TF1020 | 36 | FLAIL KNIFE MOUNTING CLEVIS |
| 5 | 33713 | 72 | FLAIL KNIFE - STANDARD |
| 6 | 21677 | 36 | NYLOCK NUT |
| 7 | 28086A | 2 | SKID SHOE |
| 8 | 27975A | 1 | CUTTER SHAFT GUARD |
| 9 | 21725 | 14 | HEX NUT 1/2" |
| 10 | 21990 | 14 | LOCKWASHER 1/2" |
| 11 | 21731 | 6 | CAPSCREW 1/2" X 1 1/2" |
| 12 | 28650A | 1 | GROUND ROLLER |
| 13 | 33863 | 2 | STRING GUARD,STD |
| 14 | 06533006 | 8 | FLATWASHER,1/2",SAE,L9 |
| 15 | 28700 | 1 | FLAP RETAINING BAR |
| 16 | 21633 | 11 | CAPSCREW 3/8" X 1 3/4" |
| 17 | 21988 | 28 | LOCKWASHER 3/8" |
| 18 | 28701 | 2 | DEFLECTOR FLAP |
| 19 | 21625 | 28 | HEX NUT 3/8" |
| 20 | TF1045B | 2 | GROUND ROLLER STUB SHAFT |
| 21 | 6T2330 | 8 | CAPSCREW 7/16" X 1 1/2" SOCKET HEAD |
| 22 | 28735 | 2 | ADJUSTABLE ROLLER BRACKET |
| 23 | 06520028 | 2 | BEARING,FLANGE,1-3/8,GRNDRLLR |
| 24 | 06520029 | 2 | O-RING |
| 25 | 06520027 | 2 | CAP,BEARING,GROUNDROLLER |
| 26 | 06530001 | 12 | CAPSCREW,SKT HD,8-32 X 1/2,SS |
| 27 | 6T2331 | 8 | CAPSCREW 7/16" X 1" SOCKET HEAD |
| 28 | 6T2270 | 10 | PLOW BOLT 3/8" X 1 1/4" |
| 29 | 06530217 | 8 | CAPSCREW 1/2" X 2",L9 |
| 30 | 28683 | 2 | FLANGE BEARING |
| 31 | TF1032 | 1 | FLANGE BEARING GREASE HOSE |
| 32 | 6T2615 | 7 | FENDER WASHER 3/8" |
| 33 | 6T2283 | 7 | CARRIAGE BOLT 3/8" X 1" |
| 34 | 28665A | 1 | BAFFLE (INSIDE UPPER REAR OF CUTTER HEAD) |

COMMON BENGAL T4

BOOM FLAIL PIVOT ASSEMBLY

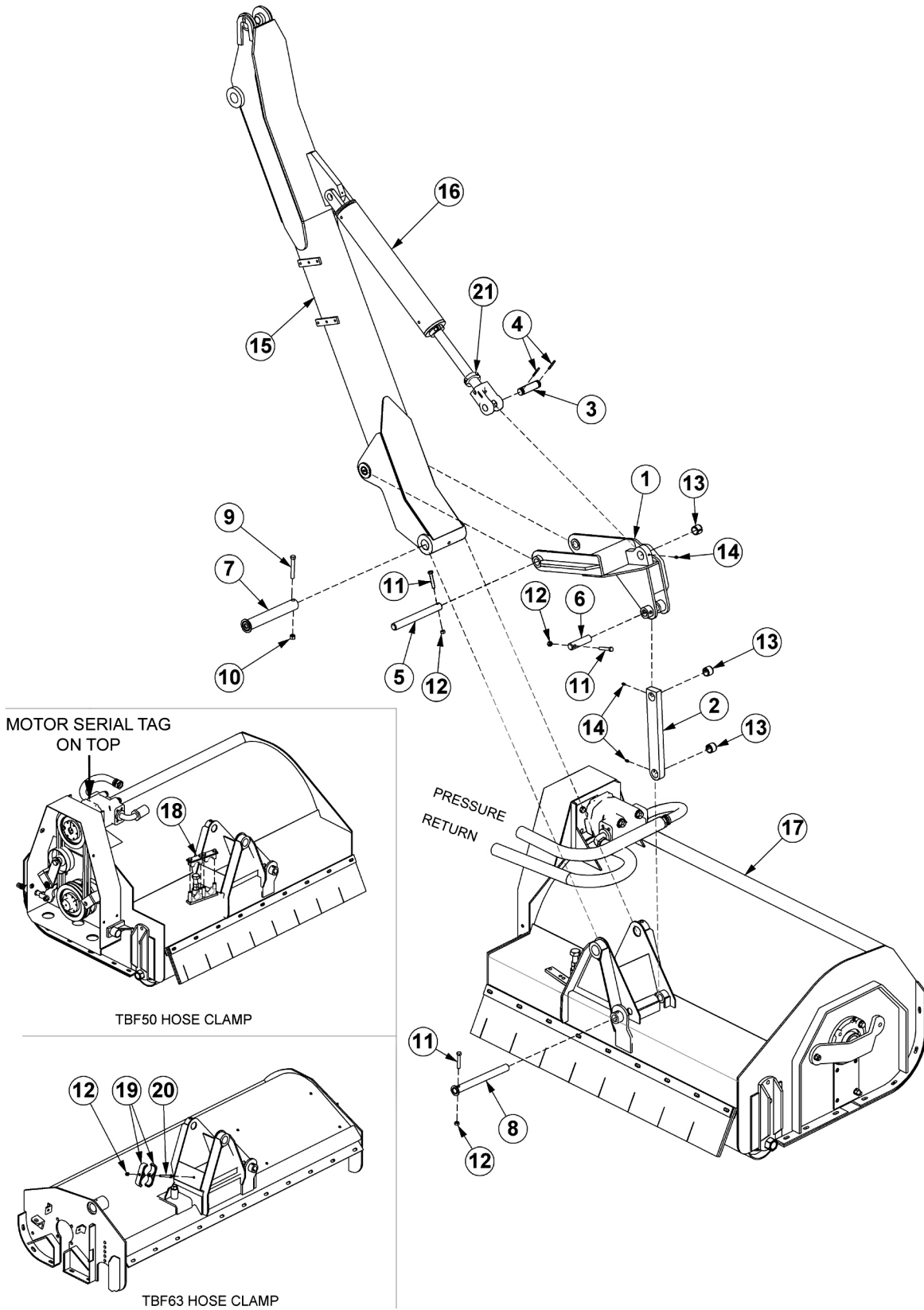

BOOM FLAIL PIVOT ASSEMBLY

Continued...

| ITEM | PART NO. | QTY. | DESCRIPTION |
|------|----------|------|---|
| 1 | TF3015 | 1 | FLAIL PIVOT ASSY |
| 2 | TB1028 | 1 | PIVOT ARM ASSY |
| 3 | TB1033 | 1 | PIN CLEVIS |
| 4 | 06537021 | 2 | ROLL PIN |
| 5 | TF3097 | 1 | PIN |
| 6 | TF3090 | 1 | PIN |
| 7 | TB1024 | 1 | PIN |
| 8 | TB1027 | 1 | PIN |
| 9 | 21688 | 1 | CAPSCREW 7/16" X 3 1/4" |
| 10 | 21677 | 1 | NYLOCK NUT 7/16" |
| 11 | 21635 | 3 | CAPSCREW 3/8" X 2 1/4" |
| 12 | 21627 | 4 | NYLOCK NUT 3/8" |
| 13 | TB5030 | 3 | BUSHING |
| 14 | 6T3207 | 3 | GREASE ZERK |
| 15 | ----- | - | SECONDARY BOOM *REFER TO BOOM ARM ASSY |
| 16 | ----- | - | CYLINDER - REFER TO BOOM ARM ASSY |
| 17 | ----- | - | FLAIL MOWER HEAD *REFER TO FLAIL ASSY |
| 18 | 31723 | 1 | CLAMP KIT,TBF50 (USED ON 50" FLAIL) |
| 19 | TB3031 | 2 | DOUBLE HOSE CLAMP (USED ON THE 63" FLAIL) |
| 20 | 21638 | 1 | CAPSCREW 3/8" X 3" |
| 21 | 35312 | 2 | SPLIT COLLAR |

3IN X 13-7/8 IN WELDED CYLINDER BREAKDOWN

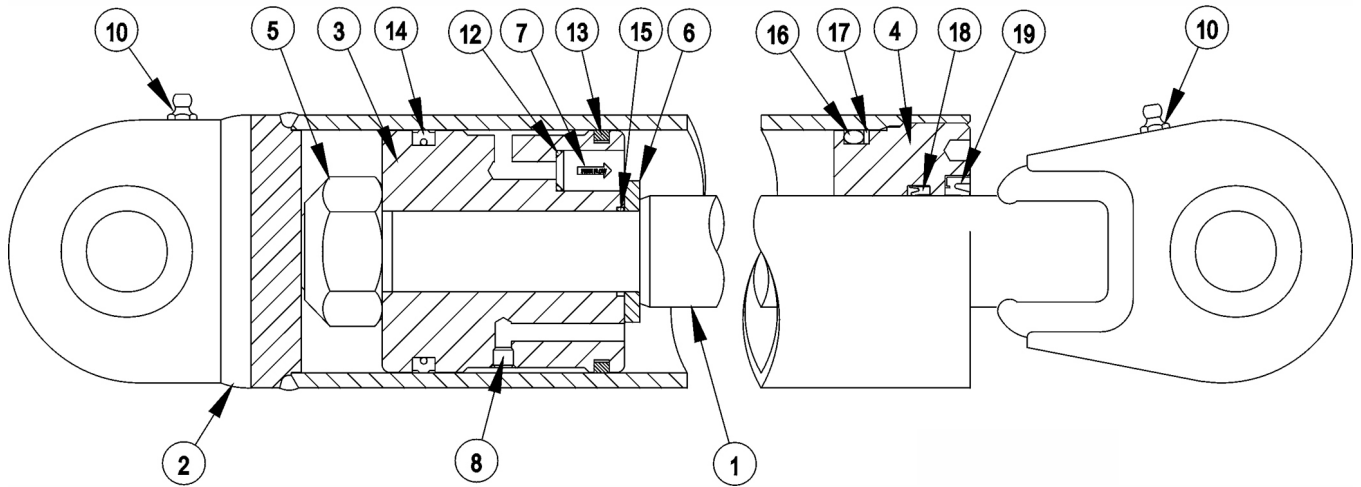

WARNING - MECHANICAL FASTENERS MUST BE TORQUED TO RECOMMENDED SPECIFICATIONS DURING REPAIR TO PREVENT PERSONAL INJURY OR EQUIPMENT DAMAGE.

| ITEM | PART NO. | QTY. | DESCRIPTION |
|------|----------|------|---|
| --- | 06501029 | - | CYLINDER,WELDED,3" X 13.87" |
| 1 | 06501630 | 1 | PISTON ROD ASSY |
| 2 | 06501648 | 1 | BUTT & TUBE ASSY |
| 3 | 06501649 | 1 | PISTON |
| 4 | 34574 | 1 | GLAND |
| 5 | 34575 | 1 | LOCK NUT,1"-14 UNS (TORQUE TO 315 FT.LB.) |
| 6 | 34576 | 1 | SPACER |
| 7 | 34577 | 1 | CHECK VALVE,KEPNER |
| 8 | 06501650 | 1 | ORIFICE, ZERO LEAK, 0225 |
| 9 | 33761 | 1 | SEAL KIT,PACKING (ITEMS 12 THRU 19) |
| 10 | ----- | 2 | GREASE ZERK |
| 12 | ----- | 1 | O - RING |
| 13 | ----- | 1 | CAST IRON PISTON RING |
| 14 | ----- | 1 | CROWN SEAL |
| 15 | ----- | 1 | O - RING |
| 16 | ----- | 1 | O - RING |
| 17 | ----- | 1 | BACK - UP WASHER |
| 18 | ----- | 1 | U - CUP |
| 19 | ----- | 1 | WIPER |
| 20 | 34334 | - | SPHERICAL BEARING (NOT SHOWN) |

3IN X 18IN WELDED CYLINDER BREAKDOWN

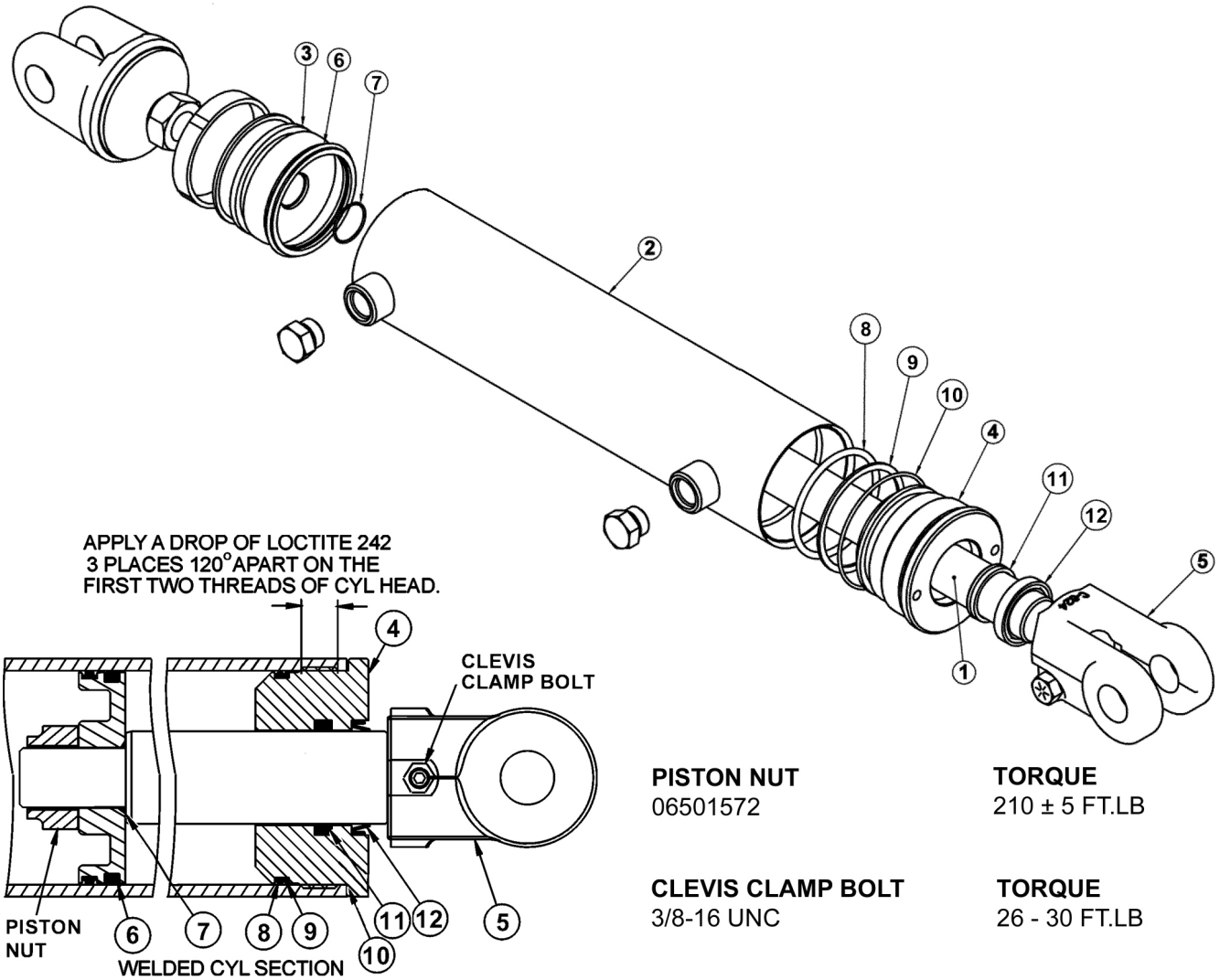

WARNING - MECHANICAL FASTENERS MUST BE TORQUED TO RECOMMENDED SPECIFICATIONS DURING REPAIR TO PREVENT PERSONAL INJURY OR EQUIPMENT DAMAGE.

| ITEM | PART NO. | QTY. | DESCRIPTION |
|-------|----------|------|--------------------------------------|
| ----- | 06501023 | - | HYDRAULIC CYLINDER COMPLETE |
| 1 | 06501561 | 1 | ROD |
| 2 | 06501562 | 1 | TUBE WELDMENT |
| 3 | 06501552 | 1 | PISTON |
| 4 | 06501563 | 1 | CYLINDER HEAD |
| 5 | 06501554 | 1 | CLEVIS |
| ----- | 06501564 | - | SEAL REPAIR KIT (ITEMS 6 THROUGH 12) |

3-1/2IN X 20IN WELDED CYLINDER BREAKDOWN

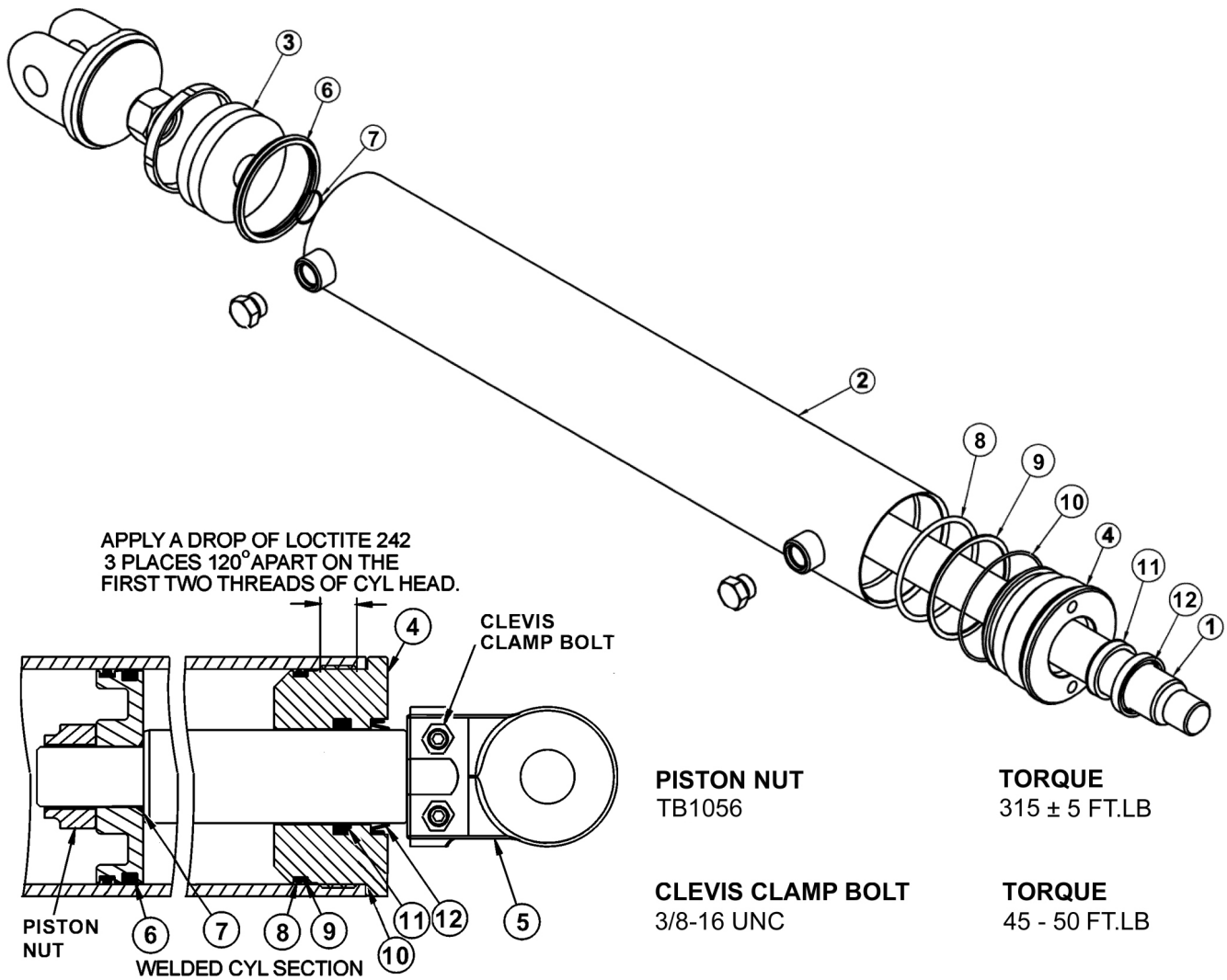

WARNING - MECHANICAL FASTENERS MUST BE TORQUED TO RECOMMENDED SPECIFICATIONS DURING REPAIR TO PREVENT PERSONAL INJURY OR EQUIPMENT DAMAGE.

| ITEM | PART NO. | QTY. | DESCRIPTION |
|-------|----------|------|--------------------------------------|
| ----- | 06501024 | - | HYDRAULIC CYLINDER COMPLETE |
| 1 | 06501565 | 1 | ROD |
| 2 | 06501566 | 1 | TUBE WELDMENT |
| 3 | 06501567 | 1 | PISTON |
| 4 | 06501568 | 1 | CYLINDER HEAD |
| 5 | TB3033 | - | CLEVIS |
| ----- | 06501569 | - | SEAL REPAIR KIT (ITEMS 6 THROUGH 12) |

4IN X 20IN WELDED CYLINDER BREAKDOWN

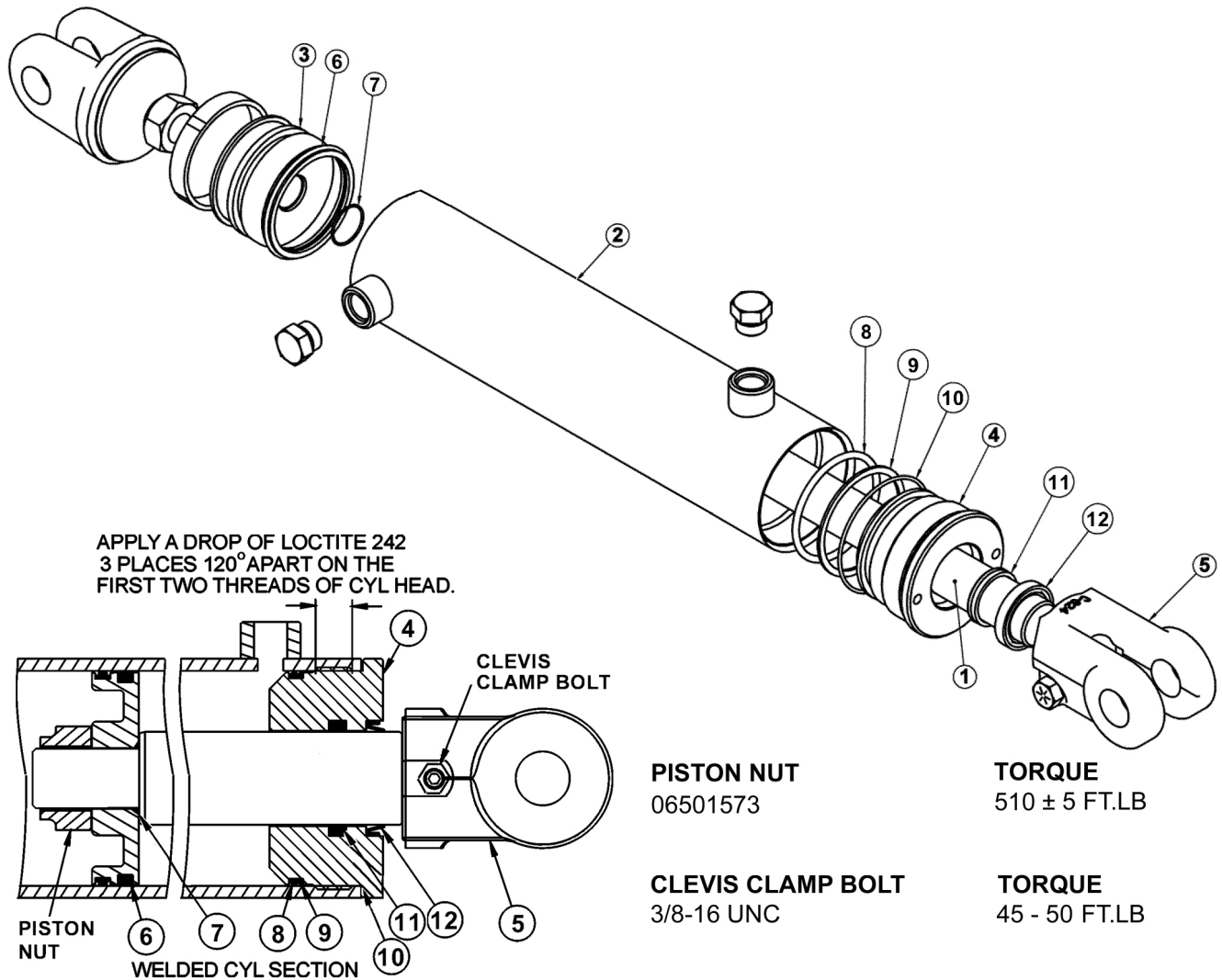

WARNING - MECHANICAL FASTENERS MUST BE TORQUED TO RECOMMENDED SPECIFICATIONS DURING REPAIR TO PREVENT PERSONAL INJURY OR EQUIPMENT DAMAGE.

| ITEM | PART NO. | QTY. | DESCRIPTION |
|-------|----------|------|--------------------------------------|
| ----- | 06501022 | - | HYDRAULIC CYLINDER COMPLETE |
| 1 | 06501556 | 1 | ROD |
| 2 | 06501557 | 1 | TUBE WELDMENT |
| 3 | 06501558 | 1 | PISTON |
| 4 | 06501559 | 1 | CYLINDER HEAD |
| 5 | 6T0172 | 1 | CLEVIS |
| 5A | 30172 | - | CLEVIS (FOR EXTENDED BOOM) |
| ----- | 06501560 | - | SEAL REPAIR KIT (ITEMS 6 THROUGH 12) |

5IN X 20IN WELDED CYLINDER BREAKDOWN

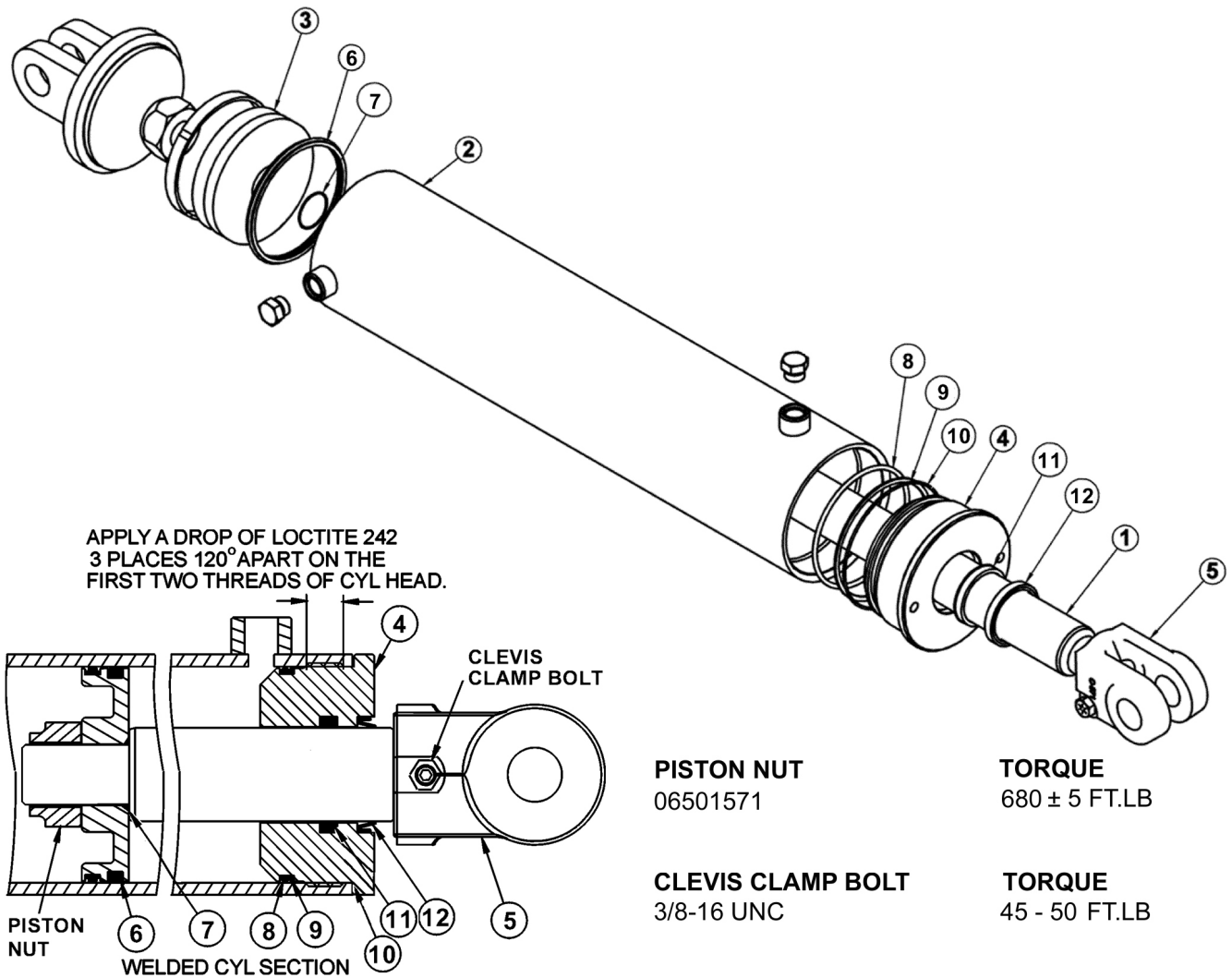

WARNING - MECHANICAL FASTENERS MUST BE TORQUED TO RECOMMENDED SPECIFICATIONS DURING REPAIR TO PREVENT PERSONAL INJURY OR EQUIPMENT DAMAGE.

| ITEM | PART NO. | QTY. | DESCRIPTION |
|-------|----------|------|--------------------------------------|
| ----- | 06501020 | - | HYDRAULIC CYLINDER COMPLETE |
| 1 | 06501544 | 1 | ROD |
| 2 | 06501545 | 1 | TUBE WELDMENT |
| 3 | 06501546 | 1 | PISTON |
| 4 | 06501547 | 1 | CYLINDER HEAD |
| 5 | 06501548 | 1 | CLEVIS |
| ----- | 06501549 | - | SEAL REPAIR KIT (ITEMS 6 THROUGH 12) |

NOTES

NOTES

5 SPOOL ELECTRONIC VALVE - OPEN STOW,3PS

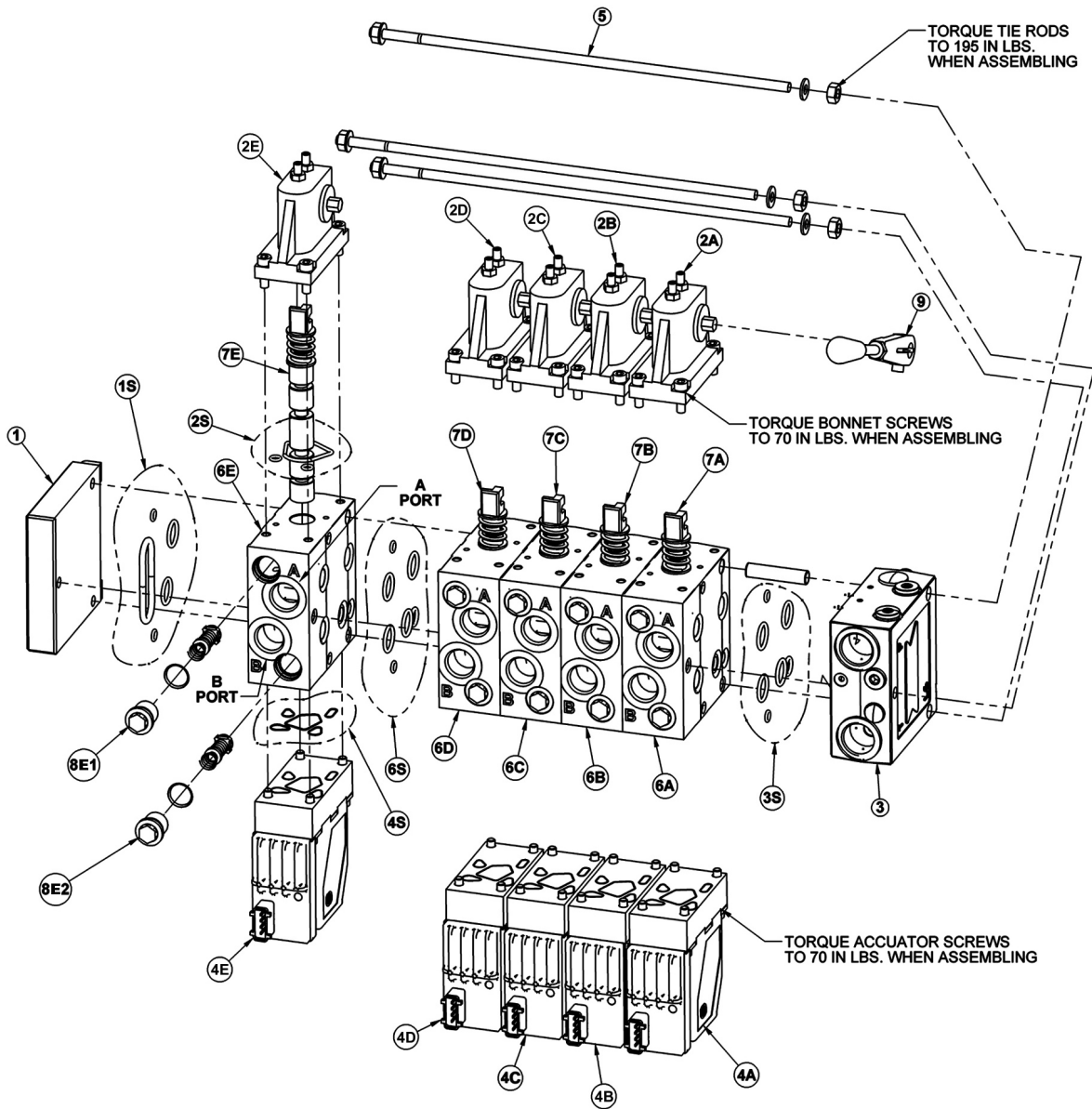

| ITEM | PART NO. | QTY. | DESCRIPTION |
|-------|----------|------|------------------------------|
| ----- | 06502097 | - | VLV,5SP,32PVG,OPEN STOW, 3OS |
| 1 | 06502074 | 1 | END PLATE |
| 1S | 06505013 | 1 | END PLATE SEAL KIT |
| 2 | ----- | 5 | BONNET |
| 2S | 06505042 | 1 | BONNET SEAL KIT |
| 2A | 42197 | 1 | MAIN BOOM BONNET |
| 2B | 42197 | 1 | SECONDARY BOOM BONNET |
| 2C | 42197 | 1 | DECK ROLL BONNET |
| 2D | 42197 | 1 | BOOM SWIVEL BONNET |
| 2E | 42197 | 1 | DECK SHIELD BONNET |

5 SPOOL ELECTRONIC VALVE - OPEN STOW,3PS

Continued...

| ITEM | PART NO. | QTY. | DESCRIPTION |
|------|----------|------|------------------------------------|
| 3 | 34308 | 1 | INLET SECTION |
| 3S | 06505013 | 1 | INLET SECTION SEAL KIT |
| 4 | ----- | 5 | ELECTRONIC ACCUATOR |
| 4A | 06502101 | 1 | MAIN BOOM ELECTRONIC ACCUATOR |
| 4B | 06502101 | 1 | SECONDARY BOOM ELECTRONIC ACCUATOR |
| 4C | 06502100 | 1 | DECK ROLL ELECTRONIC ACCUATOR |
| 4D | 06502101 | 1 | BOOM SWIVEL ELECTRONIC ACCUATOR |
| 4E | 06502099 | 1 | DECK SHIELD ELECTRONIC ACCUATOR |
| 5 | 42202 | 1 | TIE-BOLT KIT |
| 6 | ----- | 5 | SECTION |
| 6S | 06505013 | 1 | SECTION SEAL KIT |
| 6A | 42698 | 1 | MAIN BOOM SECTION |
| 6B | 42698 | 1 | SEC BOOM SECTION |
| 6C | 06502076 | 1 | DECK ROLL SECTION |
| 6D | 42698 | 1 | BOOM SWIVEL SECTION |
| 6E | 06502077 | 1 | SHIELD SECTION |
| 7 | ----- | 5 | SPOOL |
| 7A | 42697 | 1 | MAIN BOOM SPOOL |
| 7B | 42697 | 1 | SEC BOOM SPOOL |
| 7C | 4242106 | 1 | DECK ROLL SPOOL |
| 7D | 06502073 | 1 | BOOM SWIVEL SPOOL |
| 7E | 42201 | 1 | DECK SHIELD SPOOL |
| 8 | ----- | 10 | ANTI CAV/SHOCK RELIEF |
| 8A1 | 06502084 | 1 | MAIN BOOM A PORT RELIEF |
| 8A2 | 06502081 | 1 | MAIN BOOM B PORT RELIEF |
| 8B1 | 42296 | 1 | SEC BOOM A PORT RELIEF |
| 8B2 | 06502082 | 1 | SEC BOOM B PORT RELIEF |
| 8C1 | 42295 | 1 | DECK ROLL A PORT RELIEF |
| 8C2 | 06502082 | 1 | DECK ROLL B PORT RELIEF |
| 8D1 | 06502070 | 1 | BOOM SWIVEL A PORT RELIEF |
| 8D2 | 06502083 | 1 | BOOM SWIVEL B PORT RELIEF |
| 8E1 | 06502081 | 1 | DECK SHIELD A PORT RELIEF |
| 8E2 | 06502081 | 1 | DECK SHIELD B PORT RELIEF |
| 9 | 33459 | 1 | HANDLE |

COMMON BENGAL T4

5 SPOOL ELECTRONIC VALVE - SIDE STOW

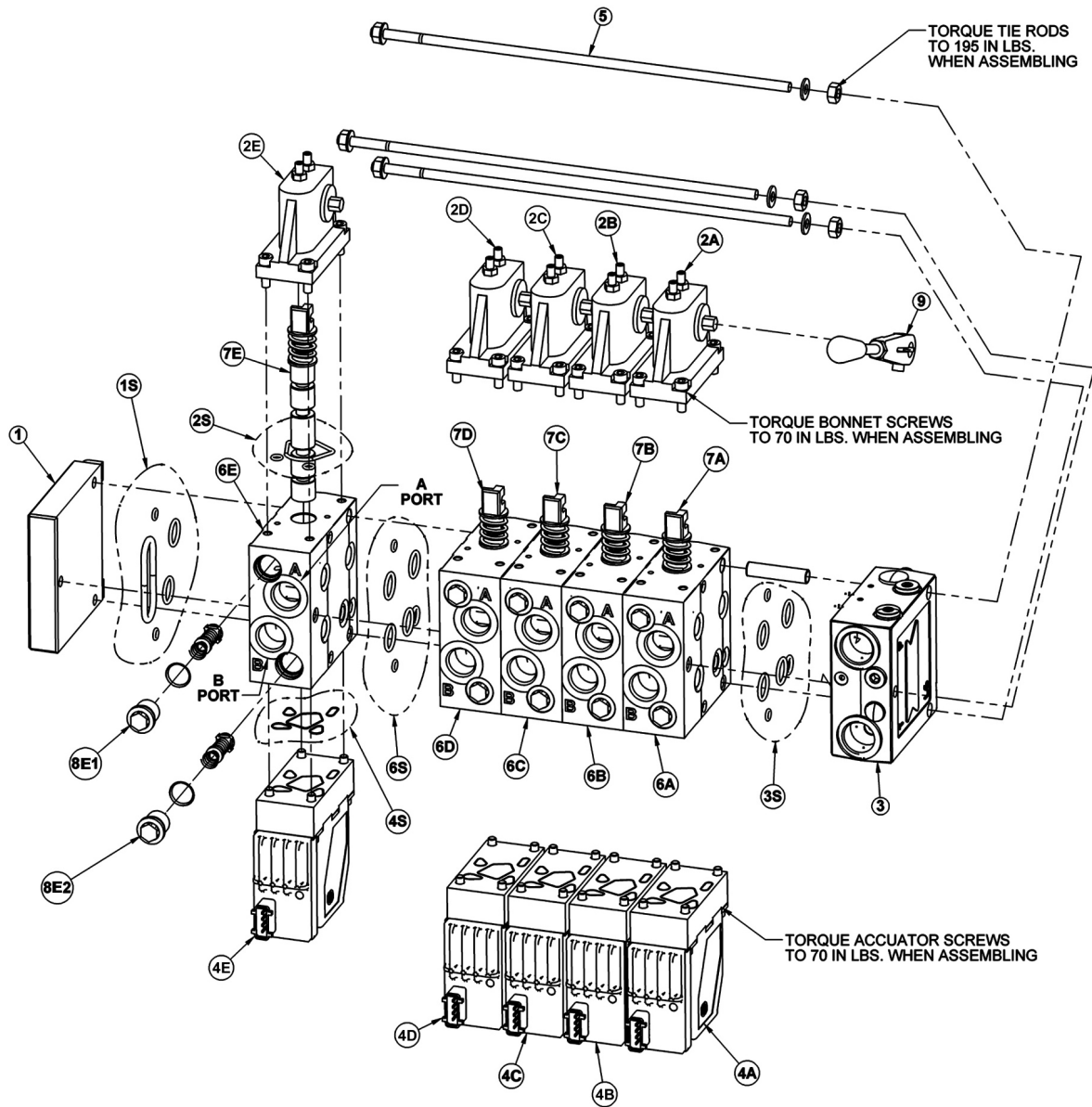

| ITEM | PART NO. | QTY. | DESCRIPTION |
|-------|----------|------|-------------------------|
| ----- | 06502096 | - | VLV,5SP,32PVG,SIDE STOW |
| 1 | 06502074 | 1 | END PLATE |
| 1S | 06505013 | 1 | END PLATE SEAL KIT |
| 2 | ----- | 5 | BONNET |
| 2S | 06505042 | 1 | BONNET SEAL KIT |
| 2A | 42197 | 1 | MAIN BOOM BONNET |
| 2B | 42197 | 1 | SECONDARY BOOM BONNET |
| 2C | 42197 | 1 | DECK ROLL BONNET |
| 2D | 42197 | 1 | BOOM SWIVEL BONNET |
| 2E | 42197 | 1 | DECK SHIELD BONNET |

5 SPOOL ELECTRONIC VALVE - SIDE STOW

Continued...

| ITEM | PART NO. | QTY. | DESCRIPTION |
|------|----------|------|------------------------------------|
| 3 | 34308 | 1 | INLET SECTION |
| 3S | 06505013 | 1 | INLET SECTION SEAL KIT |
| 4 | ----- | 5 | ELECTRONIC ACCUATOR |
| 4A | 06502101 | 1 | MAIN BOOM ELECTRONIC ACCUATOR |
| 4B | 06502101 | 1 | SECONDARY BOOM ELECTRONIC ACCUATOR |
| 4C | 06502100 | 1 | DECK ROLL ELECTRONIC ACCUATOR |
| 4D | 06502101 | 1 | BOOM SWIVEL ELECTRONIC ACCUATOR |
| 4E | 06502099 | 1 | DECK SHIELD ELECTRONIC ACCUATOR |
| 5 | 42202 | 1 | TIE-BOLT KIT |
| 6 | ----- | 5 | SECTION |
| 6S | 06505013 | 1 | SECTION SEAL KIT |
| 6A | 42698 | 1 | MAIN BOOM SECTION |
| 6B | 42698 | 1 | SEC BOOM SECTION |
| 6C | 06502076 | 1 | DECK ROLL SECTION |
| 6D | 42698 | 1 | BOOM SWIVEL SECTION |
| 6E | 06502077 | 1 | SHIELD SECTION |
| 7 | ----- | 5 | SPOOL |
| 7A | 42697 | 1 | MAIN BOOM SPOOL |
| 7B | 42697 | 1 | SEC BOOM SPOOL |
| 7C | 4242106 | 1 | DECK ROLL SPOOL |
| 7D | 06502073 | 1 | BOOM SWIVEL SPOOL |
| 7E | 42201 | 1 | DECK SHIELD SPOOL |
| 8 | ----- | 10 | ANTI CAV/SHOCK RELIEF |
| 8A1 | 42650 | 1 | MAIN BOOM A PORT RELIEF |
| 8A2 | 06502069 | 1 | MAIN BOOM B PORT RELIEF |
| 8B1 | 42650 | 1 | SEC BOOM A PORT RELIEF |
| 8B2 | 42295 | 1 | SEC BOOM B PORT RELIEF |
| 8C1 | 42296 | 1 | DECK ROLL A PORT RELIEF |
| 8C2 | 42295 | 1 | DECK ROLL B PORT RELIEF |
| 8D1 | 42295 | 1 | BOOM SWIVEL A PORT RELIEF |
| 8D2 | 42295 | 1 | BOOM SWIVEL B PORT RELIEF |
| 8E1 | 06502069 | 1 | DECK SHIELD A PORT RELIEF |
| 8E2 | 06502069 | 1 | DECK SHIELD B PORT RELIEF |
| 9 | 33459 | 1 | HANDLE |

COMMON BENGAL T4

FRONT HYDRAULIC PUMP

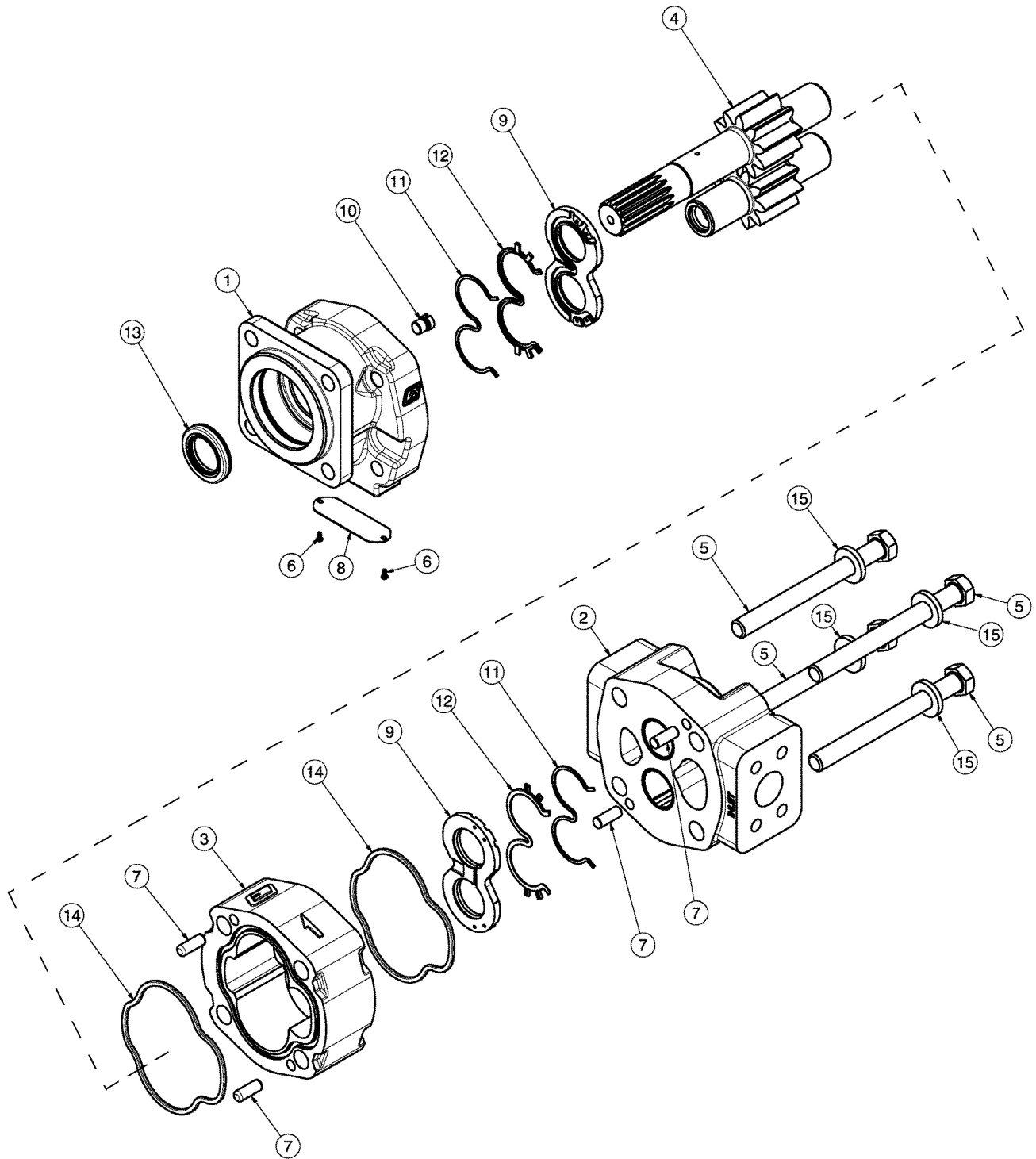

FRONT HYDRAULIC PUMP

Continued...

| ITEM | PART NO. | QTY. | DESCRIPTION |
|------|----------|------|---------------------------------------|
| --- | 23152 | 1 | PUMP ASSEMBLY,1-3/4",COMPLETE |
| 1 | 22766 | 1 | SHAFT END COVER |
| 2 | 22779 | 1 | PORT END COVER |
| 3 | 22774 | 1 | GEAR HOUSING,1-3/4" |
| 4 | 22771 | 1 | GEAR SET |
| 5 | 23824 | 4 | CAPSCREW |
| 6 | 06504078 | 2 | SCREW,DRIVE |
| 7 | 22773 | 4 | DOWEL PINS |
| 8 | 06504077 | 1 | NAMEPLATE |
| 9 | 22770 | 2 | THRUST PLATE |
| 10 | 22767 | 1 | PLUG |
| 11 | 06504075 | 2 | SEAL,BK-UP |
| 12 | 06504074 | 2 | SEAL,CHAN |
| 13 | 22765 | 1 | SEAL,LIP |
| 14 | 06504076 | 2 | SEAL,SQ-R |
| 15 | 02961917 | 4 | WASHER |
| --- | 24150 | 1 | SEAL KIT (INCLUDES 11, 12, 13 AND 14) |

50IN AND 60IN ROTARY MOTOR BREAKDOWN

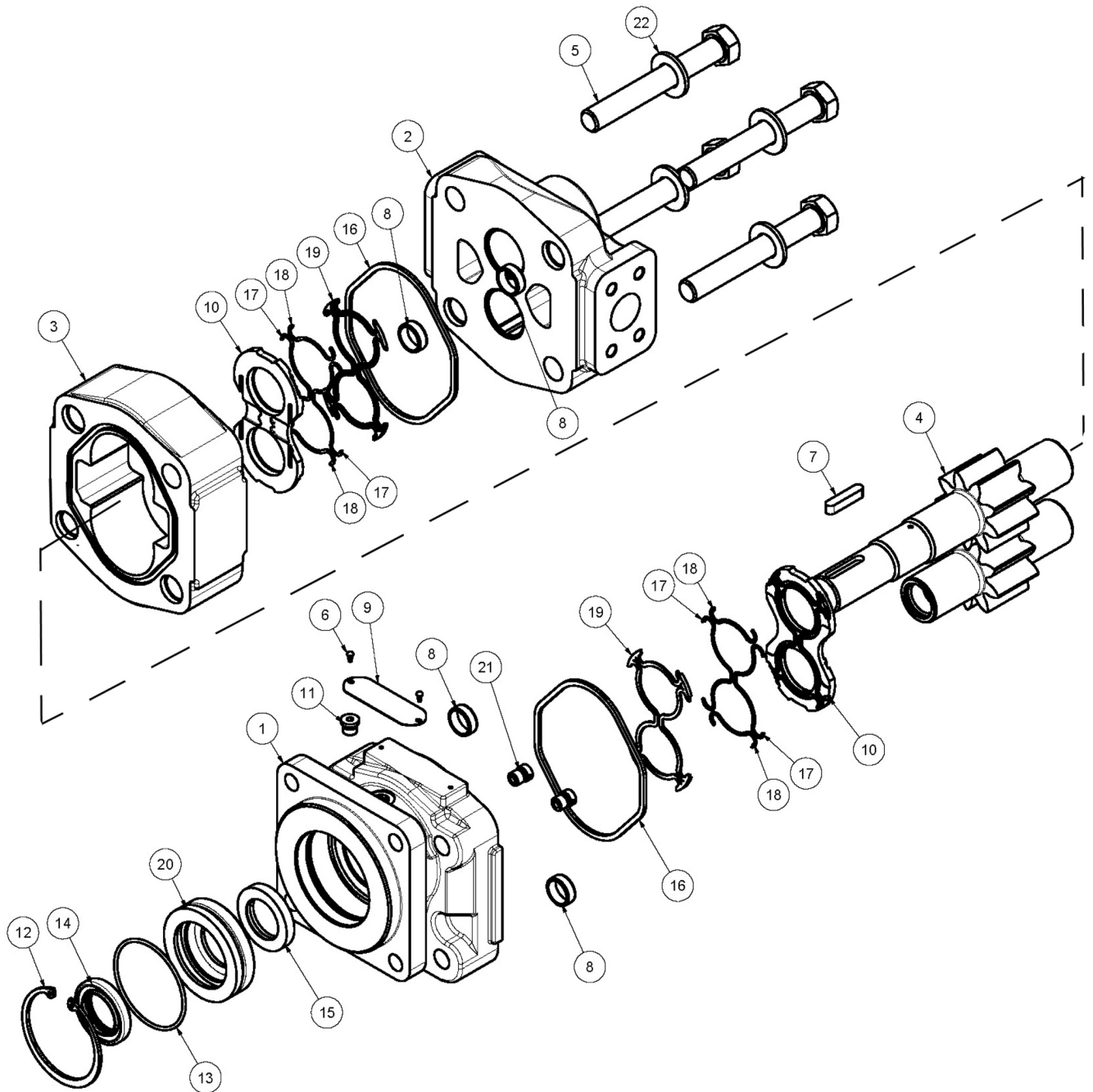

50IN AND 60IN ROTARY MOTOR BREAKDOWN

Continued...

| ITEM | PART NO. | QTY. | DESCRIPTION |
|-------|----------|------|----------------------|
| | 06504011 | - | MOTOR ASSEMBLY,TRB60 |
| | 06504012 | - | MOTOR ASSEMBLY,TRB50 |
| 1 | 22790 | 1 | HOUSING, SEC |
| 2 | 06504088 | 1 | HOUSING, PEC |
| 3 | 06504062 | 1 | HOUSING, GEAR,TRB60 |
| ----- | 06504089 | - | HOUSING, GEAR,TRB50 |
| 4 | 06504090 | 1 | SET, GEAR SHAFT |
| 5 | 06504104 | 4 | CAP SCREW,TRB60 |
| ----- | 06504091 | - | CAP SCREW,TRB50 |
| 6 | 06504078 | 2 | SCREW, DRIVE |
| 7 | 06504092 | 1 | KEY |
| 8 | 06504093 | 4 | PIN, DOWEL |
| 9 | 06504094 | 1 | NAME PLATE |
| 10 | 06504095 | 2 | THRPL |
| 11 | 2961940 | 1 | PLUG, ODT |
| 12 | 2962200 | 1 | RING, SNAP |
| 13 | 06504096 | 1 | O RING |
| 14 | 6T5101 | 1 | SEAL, LIP |
| 15 | 06504097 | 1 | SEAL, LIP |
| 16 | 22797 | 2 | SEAL, SQ-R |
| 17 | 06504098 | 4 | SEAL, SIDE CHAN |
| 18 | 06504099 | 4 | SEAL, END CHAN |
| 19 | 06504100 | 2 | SEAL, BK-UP |
| 20 | 06504101 | 1 | RTNR, SEAL |
| 21 | 6T5809 | 2 | CHECK ASS'Y |
| 22 | 06504102 | 4 | WASHER |
| ----- | 06504103 | - | SEAL KIT |

FLAIL MOTOR BREAKDOWN

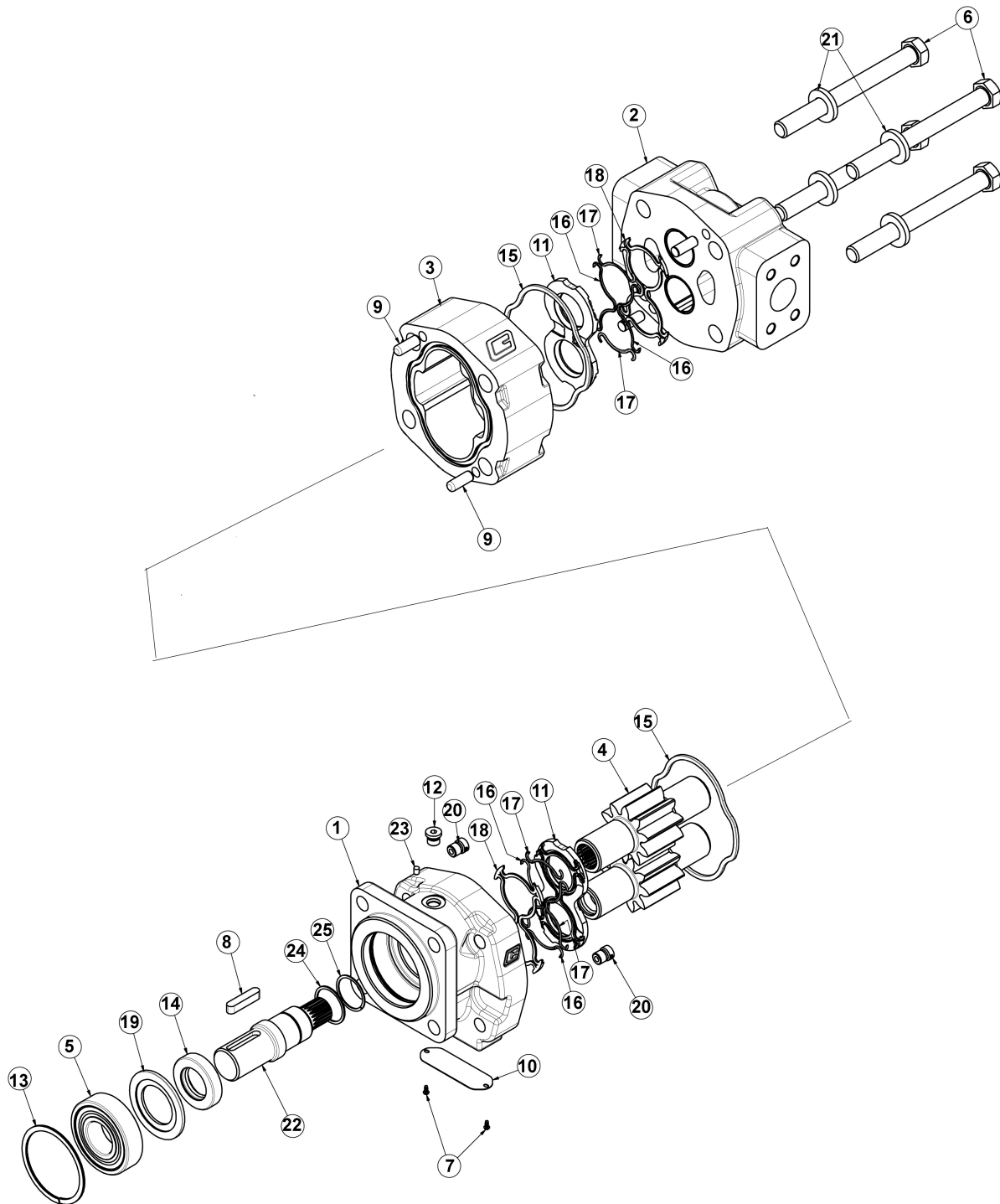

FLAIL MOTOR BREAKDOWN

Continued...

| ITEM | PART NO. | QTY. | DESCRIPTION |
|------|----------|------|-----------------------------------|
| * | 06504132 | - | MOTOR ASSEMBLY 350 - TBF50, TBF63 |
| 1 | 06504141 | 1 | SHAFT END COVER |
| 2 | 06504040 | 1 | PORT END COVER |
| 3 | 06504041 | 1 | GEAR HOUSING |
| 4 | 06504117 | 1 | MATCHED GEAR SET |
| 5 | TF4402 | 1 | BALL BEARING |
| 6 | 06504043 | 4 | CAP SCREW |
| 7 | 06504044 | 2 | SET SCREW |
| 8 | 06504028 | 1 | KEY |
| 9 | 06504045 | 4 | DOWEL PIN |
| 10 | * | 1 | NAMEPLATE |
| 11 | 763759 | 1 | THRUSTPLATE |
| 12 | 2961940 | 1 | PLUG, ODT (0.25) |
| 13 | TF4401 | 1 | SNAP RING |
| 14 | 06504142 | 1 | LIP SEAL |
| 15 | TF4410 | 2 | GASKET SEAL |
| 16 | 06504046 | 4 | SIDE SEAL |
| 17 | 06504047 | 4 | END SEAL |
| 18 | TF4407 | 2 | BACK-UP SEAL |
| 19 | 06504122 | 1 | SEAL RETAINER |
| 20 | 6T5809 | 2 | CHECK ASSEMBLY |
| 21 | 2961917 | 4 | WASHER |
| 22 | 06504140 | 1 | SHAFT |
| 23 | 06504139 | 1 | BREATHER |
| 24 | 06504121 | 1 | SPACER, BRG |
| 25 | 06504119 | 1 | SNAP RING |
| * | 06504022 | - | SEAL KIT |

RESERVOIR TANK FILTER ASSEMBLY

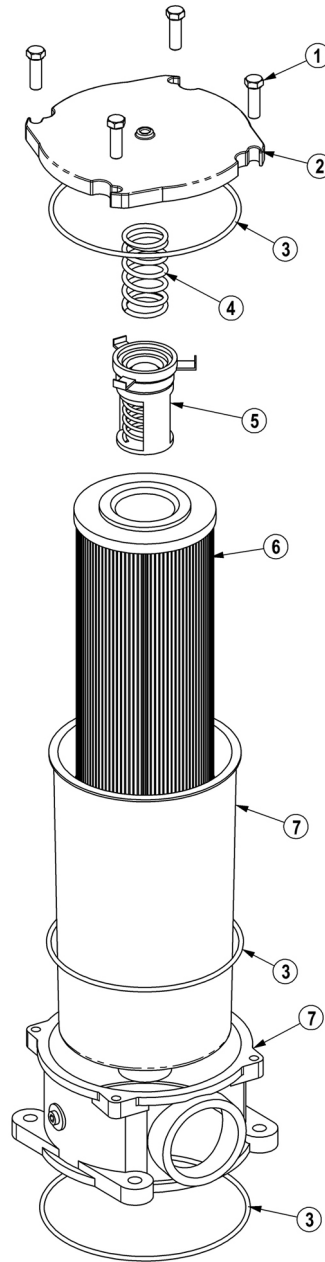

| ITEM | PART NO. | QTY. | DESCRIPTION |
|-------|----------|------|---------------------------------|
| ----- | 06505044 | - | FILTER ASSY SAE 10 MICRON |
| 1 | 28583 | 4 | CAPSCREW,8MM X 25MM(1.25 PITCH) |
| 2 | 06505045 | 1 | COVER |
| 3 | 06505046 | 1 | SEAL KIT |
| 4 | 06505047 | 1 | SPRING |
| 5 | 06505048 | 1 | BYPASS |
| 6 | 35259 | 1 | FILTER,10 MIC,RETURN LINE |
| 7 | 06505049 | 1 | CAN/BODY |

COMMON BENGAL T4

PUMP AND GRILL GUARD OPTIONS

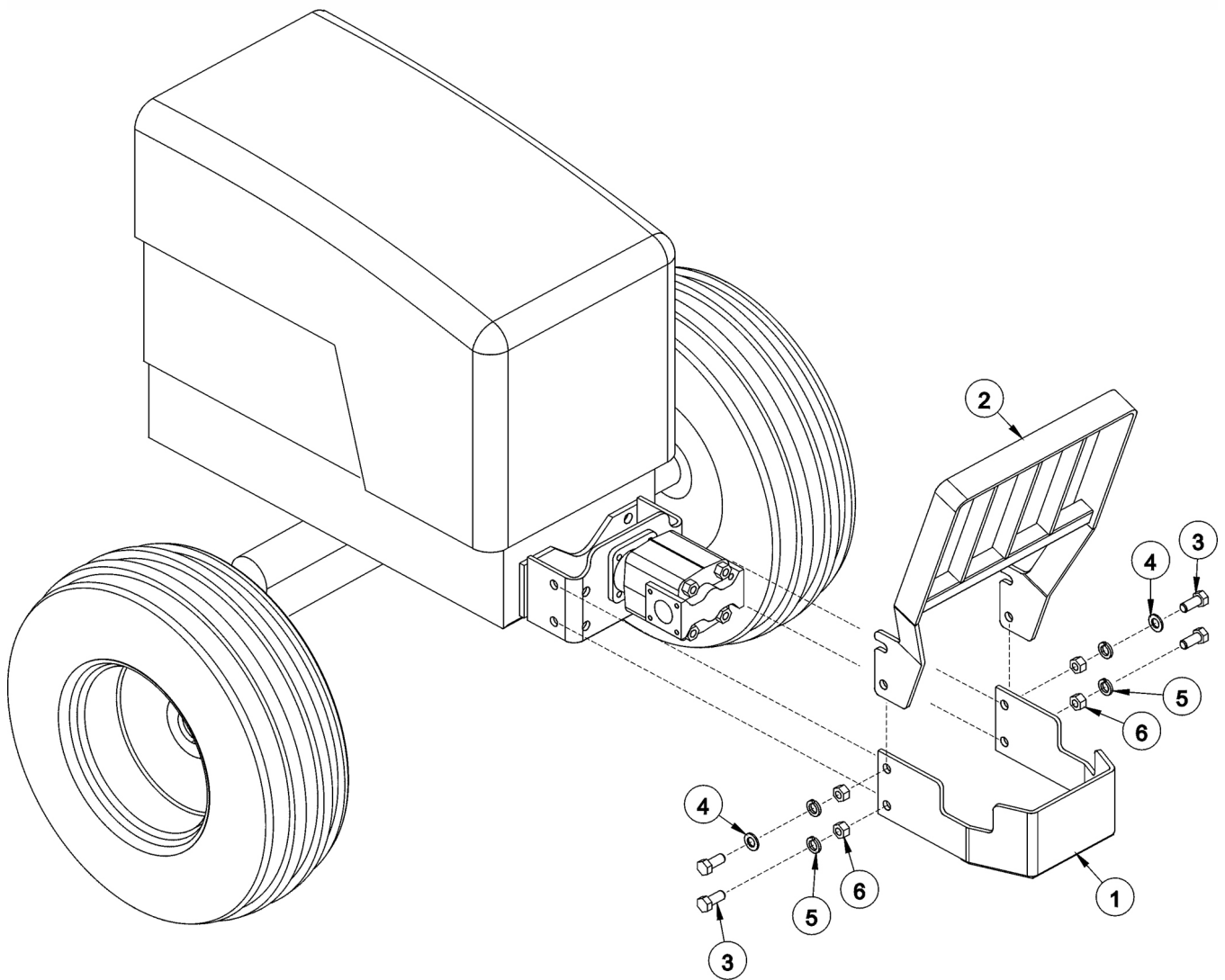

| ITEM | PART NO. | QTY. | DESCRIPTION |
|------|----------|------|---------------------------|
| 1 | 32430 | 1 | UNIVERSAL PUMP GUARD |
| 2 | 32737 | 1 | UNIVERSAL GRILL GUARD |
| 3 | 21833 | 4 | CAPSCREW,3/4" X 2-1/4",NC |
| 4 | 22021 | 2 | FLATWASHER,3/4" |
| 5 | 21993 | 4 | LOCKWASHER,3/4" |
| 6 | 21825 | 4 | HEX NUT,3/4",NC |

BOOM TRAVEL LOCK

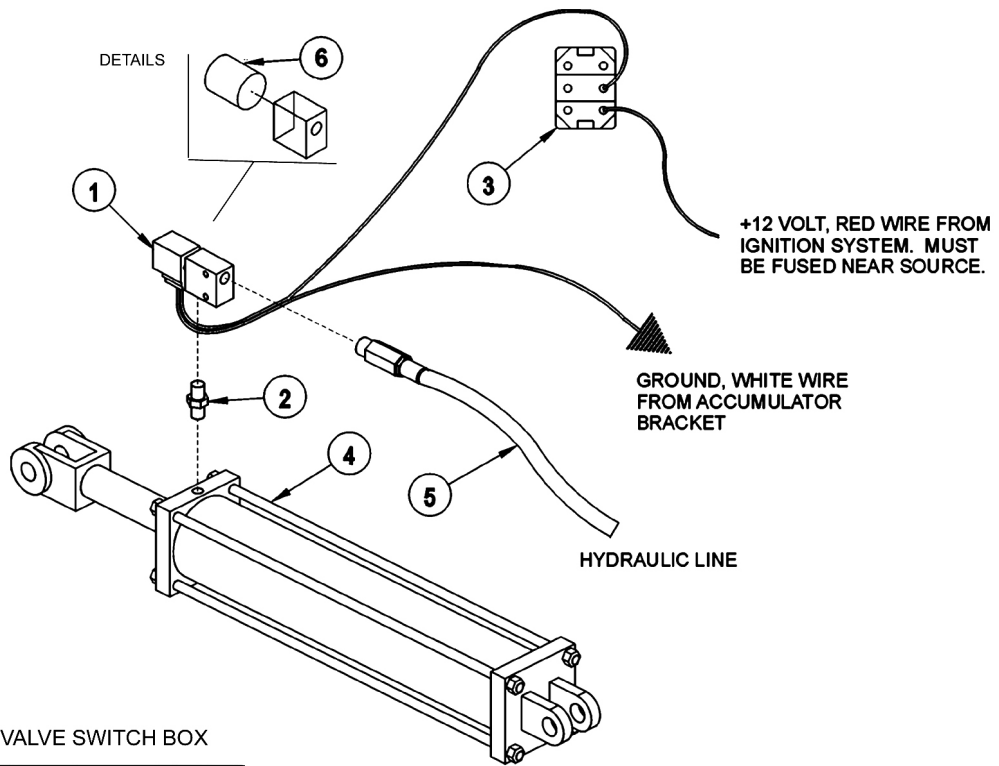

ELECTRONIC LIFT VALVE SWITCH BOX



TRAVEL LOCK SWITCH

MANUAL LIFT VALVE SWITCH BOX



TRAVEL LOCK SWITCH

| ITEM | PART NO. | QTY. | DESCRIPTION |
|-------|----------|------|---|
| 1 | 06510050 | 1 | HYDRAULIC TRAVEL LOCK VALVE |
| 2 | 31329 | 1 | ADAPTER - STANDARD BOOM |
| ----- | 31611 | 1 | ADAPTER - EXTENDED BOOM |
| 3 | 34532 | 1 | SWITCH,TRAVEL LOCK |
| 4 | ----- | - | MAIN BOOM CYLINDER *REFER TO BOOM ASSY |
| 5 | ----- | - | HOSE / FITTINGS *REFER TO BOOM HYD ASSY |
| 6 | 06510092 | 1 | COIL ,TRAVEL LOCK |

MANUAL LIFT VALVE SWITCH BOX

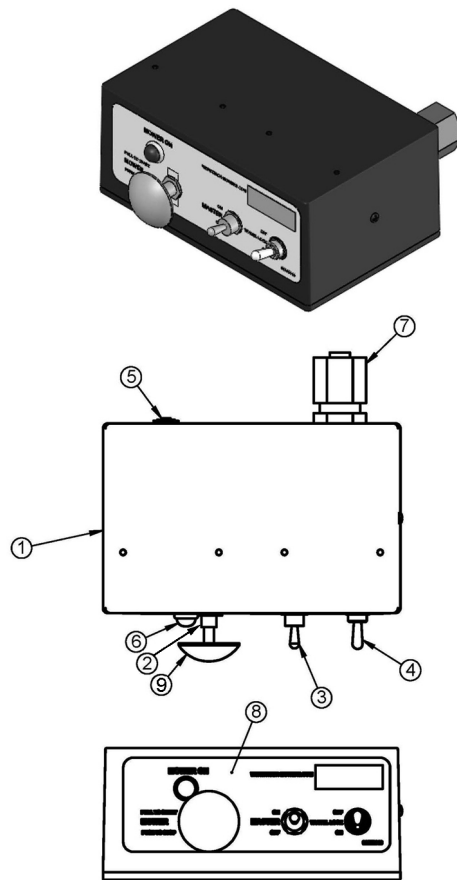

| ITEM | PART NO. | QTY. | DESCRIPTION |
|------|----------|------|-------------------------------|
| 1 | 06514012 | 1 | SWBX,ALUM,BLK,06510100 |
| 2 | 35226 | 1 | SWITCH,MOWER,COLEHERSEE |
| 3 | 33811 | 1 | SWITCH,MASTER/DECK FLOAT |
| 4 | 34532 | 1 | SWITCH,TRVL LCK |
| 5 | 06514014 | 1 | BREAKER,10A,SWBX |
| 6 | 6T3923 | 1 | INDICTATOR LIGHT,ON,RED |
| 7 | 34540 | 1 | STRAIN RELIEF,3/4,BLACK,NYLON |
| 8 | 06550019 | 1 | DECAL,SWTCHBX,BOOM,CG |
| 9 | 02964063 | 1 | KNOB,RED |
| 10 | 35227 | 1 | RELAY,DP,DT,12V,LY2F,35226 |

MANUAL LIFT VALVE SCHEMATIC

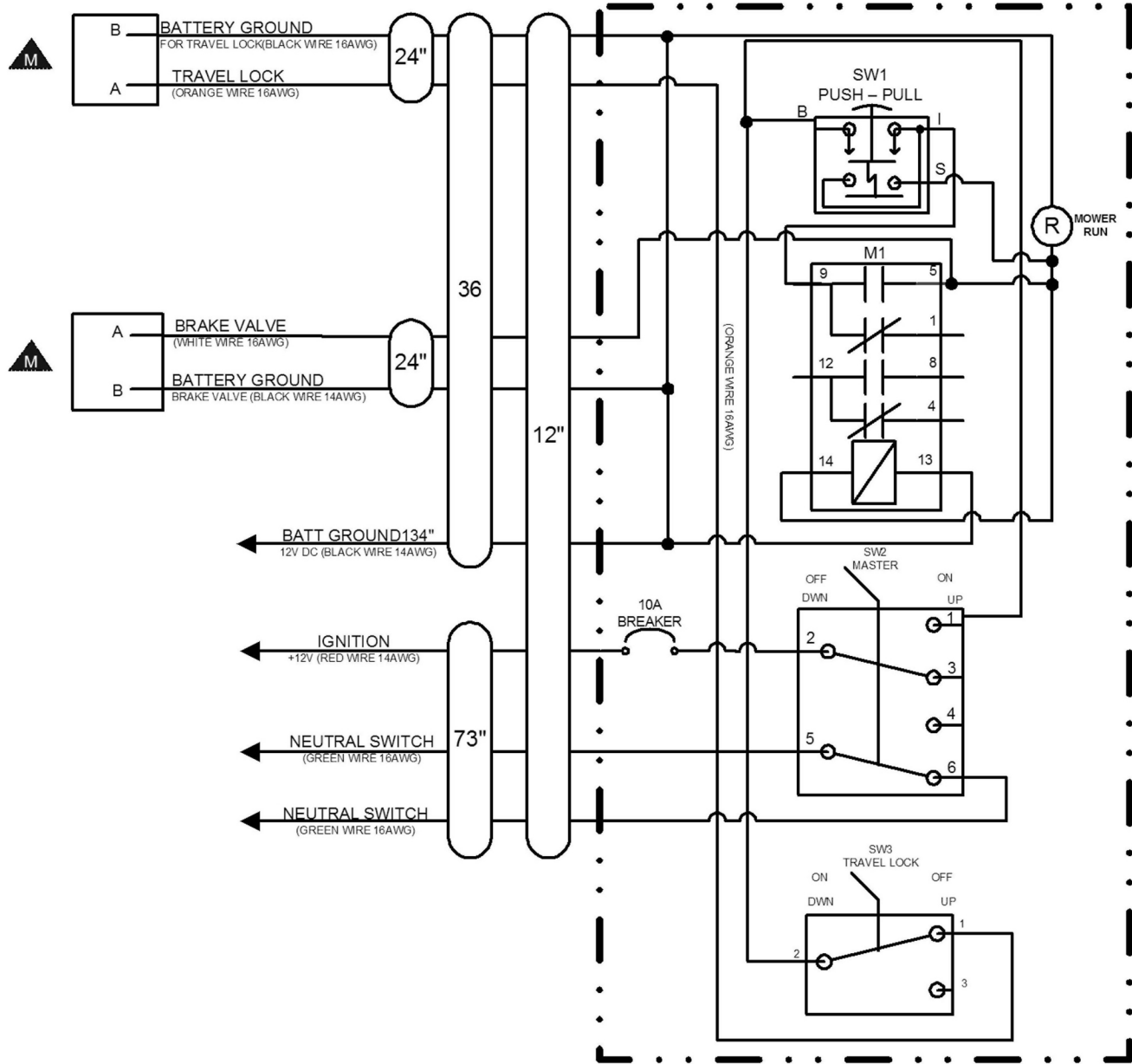

ELECTRONIC LIFT VALVE SWITCH BOX

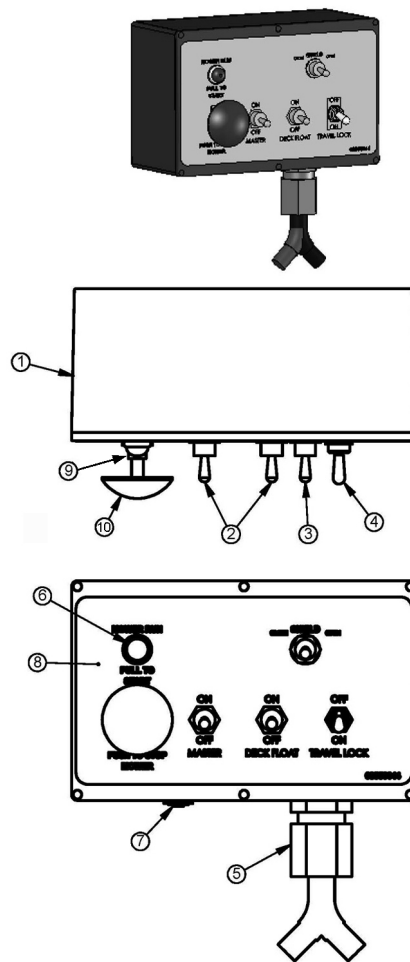

| ITEM | PART NO. | QTY. | DESCRIPTION |
|------|----------|------|--------------------------------|
| 1 | 06510196 | 1 | SWBX,ASSY |
| 2 | 33811 | 2 | SWITCH,MASTER/DECK FLOAT |
| 3 | 33813 | 1 | SWITCH,SFTY SHIELD |
| 4 | 34532 | 1 | SWITCH,TRVL LCK |
| 5 | 34540 | 1 | STRAIN RELIEF,3/4",BLACK,NYLON |
| 6 | 6T3923 | 1 | INDICTATOR LIGHT,ON,RED |
| 7 | 06514006 | 1 | BREAKER,15A,SWBX |
| 8 | 06550044 | 1 | DECAL,SWBX,06510047 |
| 9 | 35226 | 1 | SWITCH,MOWER,COLEHERSEE |
| 10 | 02964063 | 1 | KNOB,RED |
| 11 | 35227 | 1 | RELAY,DP,DT,12V,LY2F,35226 |

ELECTRONIC LIFT VALVE SCHEMATIC

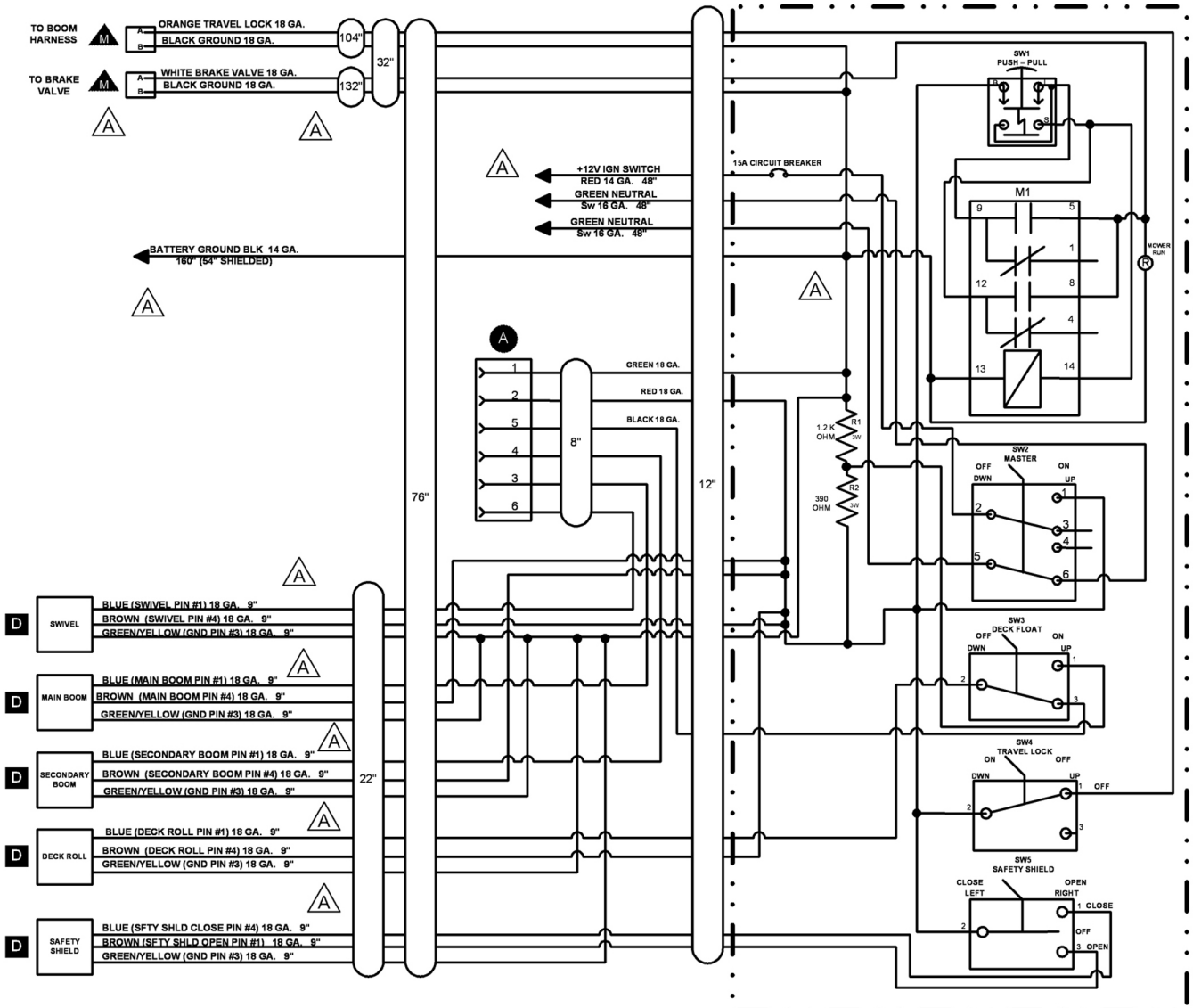

SOLENOID SWITCH BOX AND WIRING

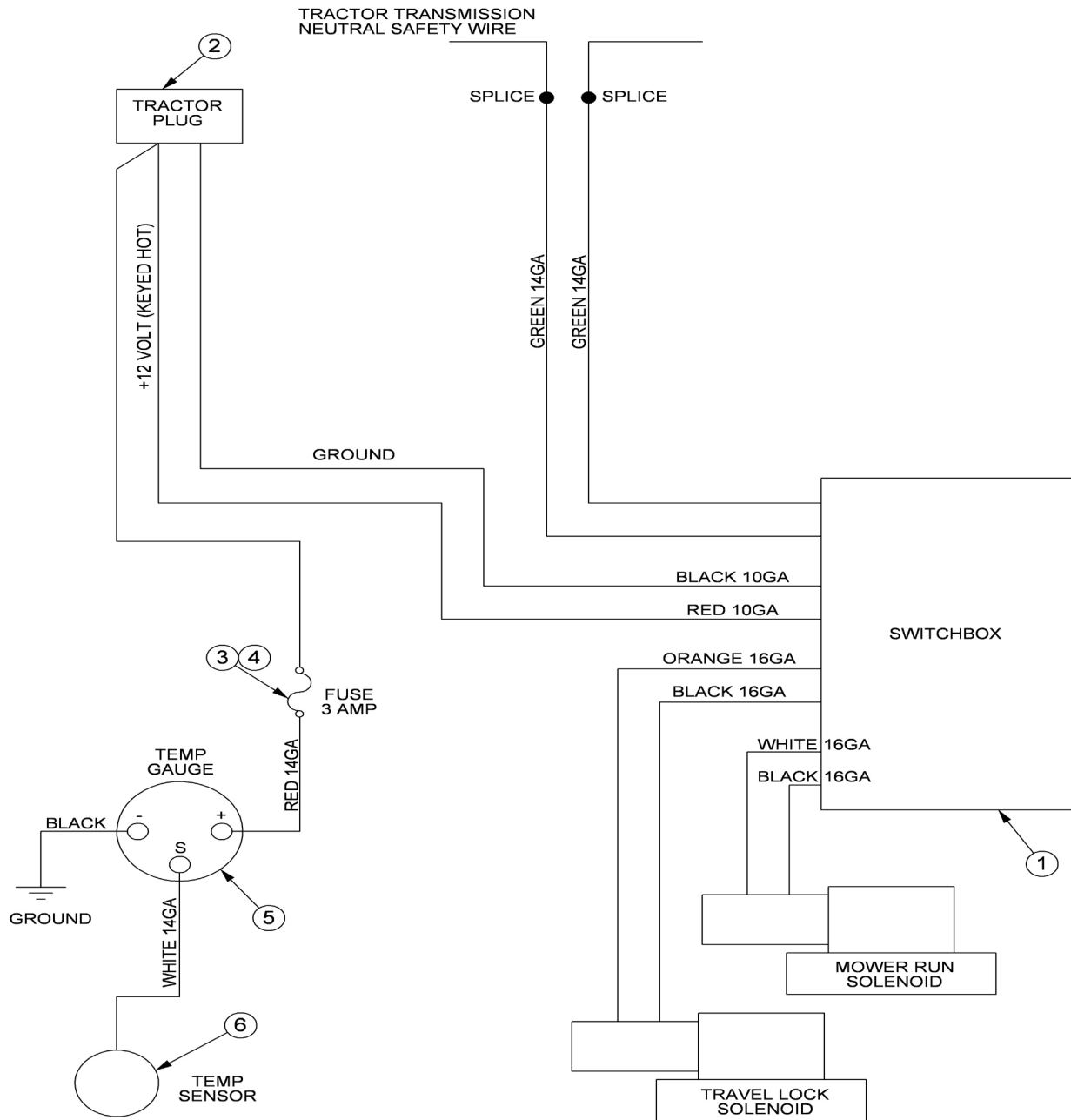

| ITEM | PART NO. | QTY. | DESCRIPTION |
|------|----------|------|------------------------------|
| 1 | ----- | - | SWITCH BOX |
| 2 | RE37651 | 1 | PLUG,AUX PWR |
| 3 | 24204 | - | FUSE HOLDER,IN-LINE (OPTION) |
| 4 | 6T3965 | - | FUSE,3AMP (OPTION) |
| 5 | 6T3934 | - | TEMPERATURE GAUGE (OPTION) |
| 6 | 6T3931 | - | TEMPERATURE SENSOR (OPTION) |

BRAKE VALVE ASSEMBLY

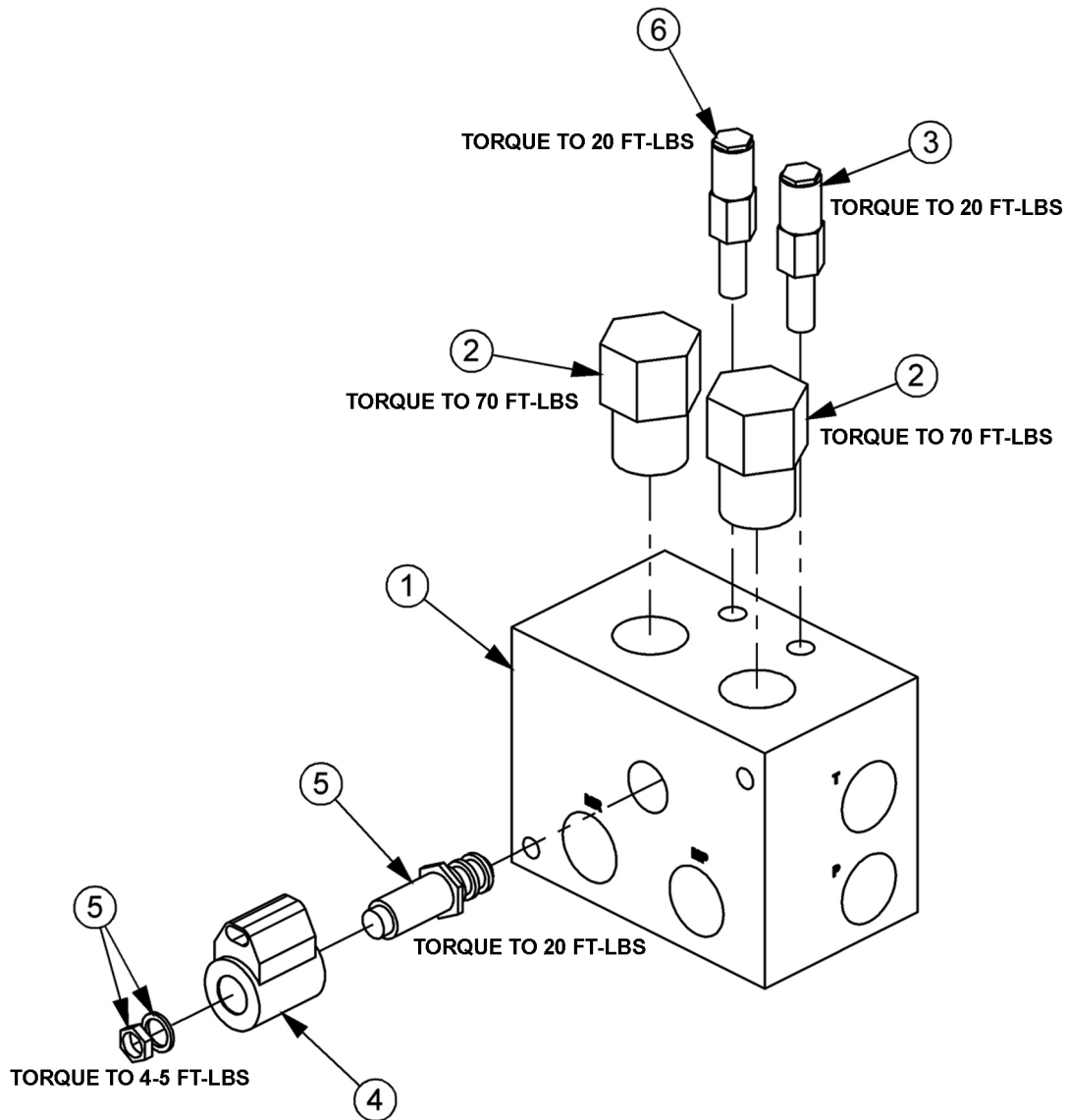

| ITEM | PART NO. | QTY. | DESCRIPTION |
|------|----------|------|--|
| --- | 06510083 | 1 | BRAKE VALVE, ASSY |
| 1 | 34092 | 1 | BRAKE VALVE, BLANK |
| 2 | 34094 | 2 | LOGIC ELEMENT |
| 3 | 34095 | 1 | RELIEF VALVE, 3000 PSI |
| 4 | 06510095 | 1 | METRI PAK COIL |
| 5 | 34093 | 1 | CARTRIDGE, 2 POSITION, 3 WAY (WITH NUT & WASHER) |
| 6 | 34091 | 1 | RELIEF VALVE, 2600 PSI |
| --- | 34096 | 2 | RELIEF SEAL KIT |
| ---- | 34097 | 1 | SOLENOID SEAL KIT |
| --- | 34098 | 2 | ELEMENT SEAL KIT |

BRAKE VALVE HYDRAULIC SCHEMATIC

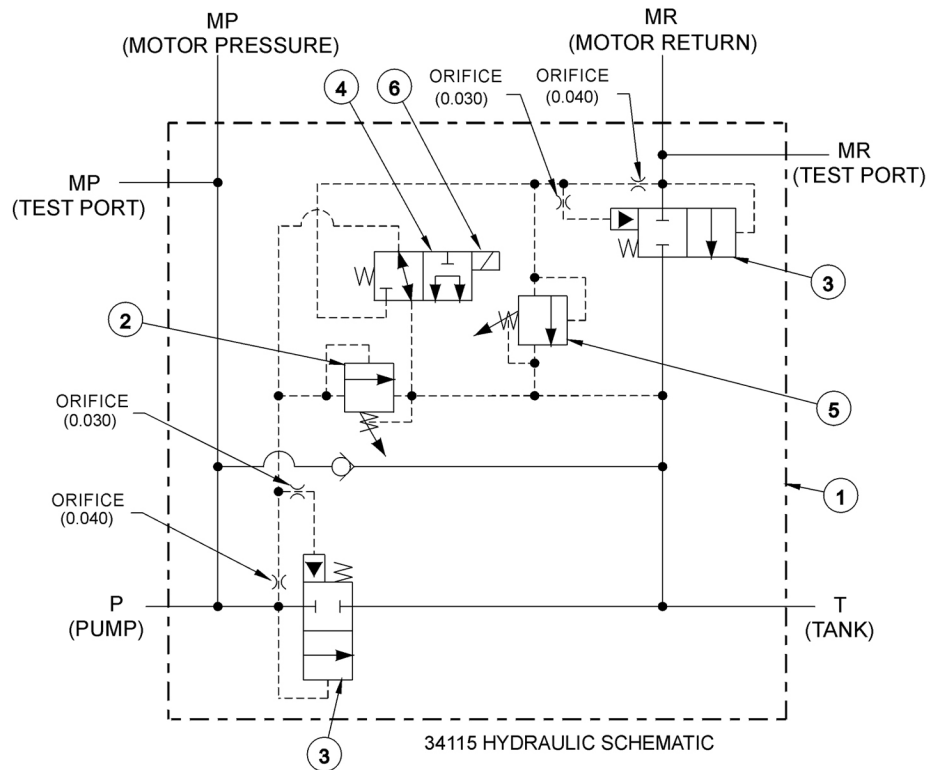

BRAKE VALVE TROUBLESHOOTING

FAILURE MODE:

- MOWER WILL NOT START - system pressure is low (engine not lugging).
- MOWER WILL NOT START - system pressure is high (engine lugging). "MR" port will be high pressure.
- MOWER WILL NOT ROTATE AT FULL SPEED - limited power.
- MOWER BLADE WILL NOT STOP - blade will not stop in proper time.

CHECK STEPS

- 1 thru 6
- 7
- 3 thru 5
- 7 thru 9

CORRECTIVE STEPS:

1. Check for voltage at solenoid (item 6), voltage must be between 10.2 volts and 13.8 volts.
2. Remove, inspect solenoid and cartridge (items 4, 6) for wear or contamination.
3. Remove, inspect logic elements near "P" port (item 3) for wear or contamination.
4. Remove, inspect 3000 psi relief valve (item 2) for wear or contamination.
5. Remove and inspect orifices near "P" port for contamination.
6. Remove "P" port hose and fitting, visually inspect for contamination, check ball for movement.
7. Remove and inspect orifices near "MR" port for contamination.
8. Remove, inspect 2600 psi relief valve (item 5) for wear or contamination.
9. Remove, inspect logic element near "MR" port (item 3) for wear or contamination.

ELECTRICAL TROUBLESHOOTING GUIDE

Joystick Electrical Troubleshooting guide

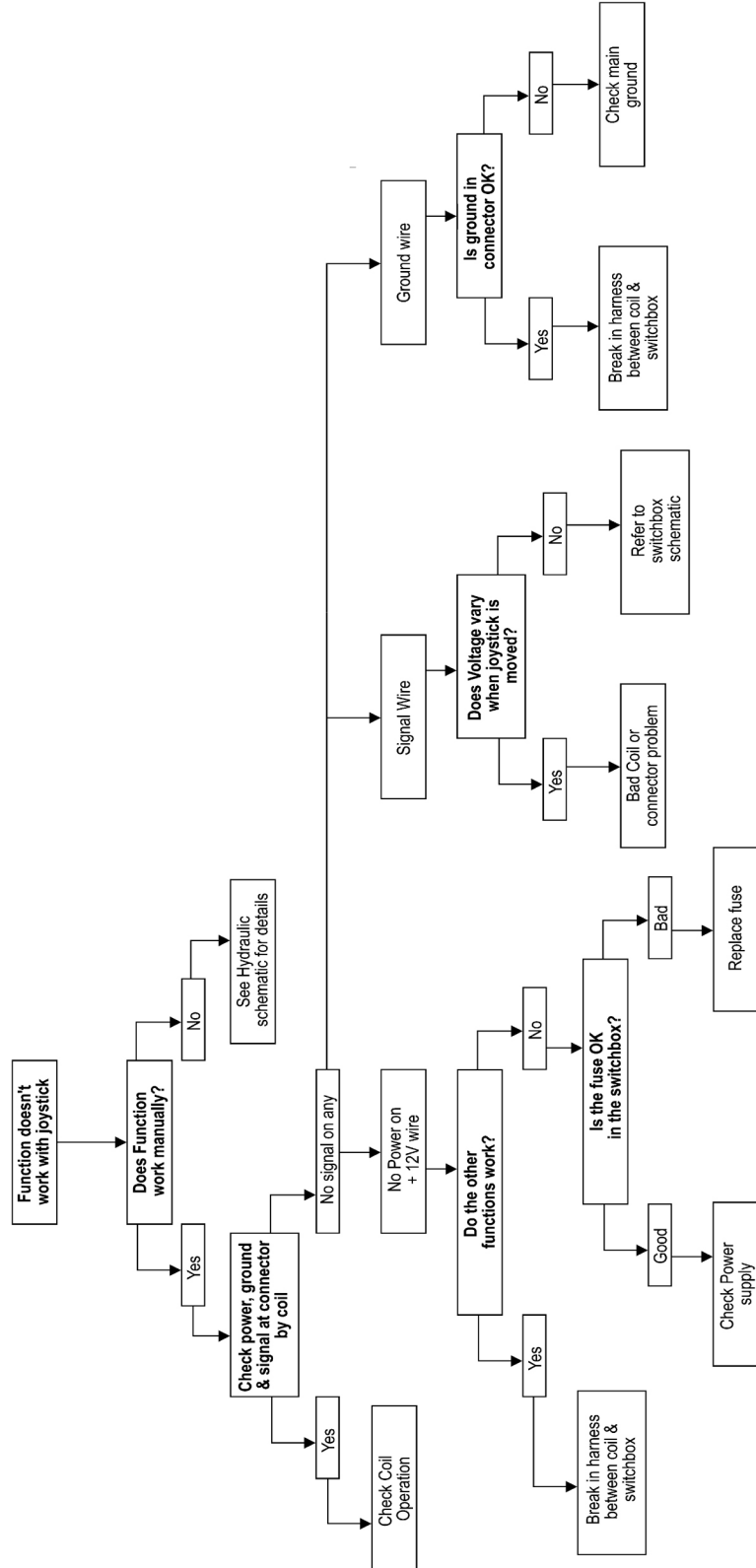

HYDRAULIC TROUBLESHOOTING GUIDE

Hydraulic Troubleshooting guide

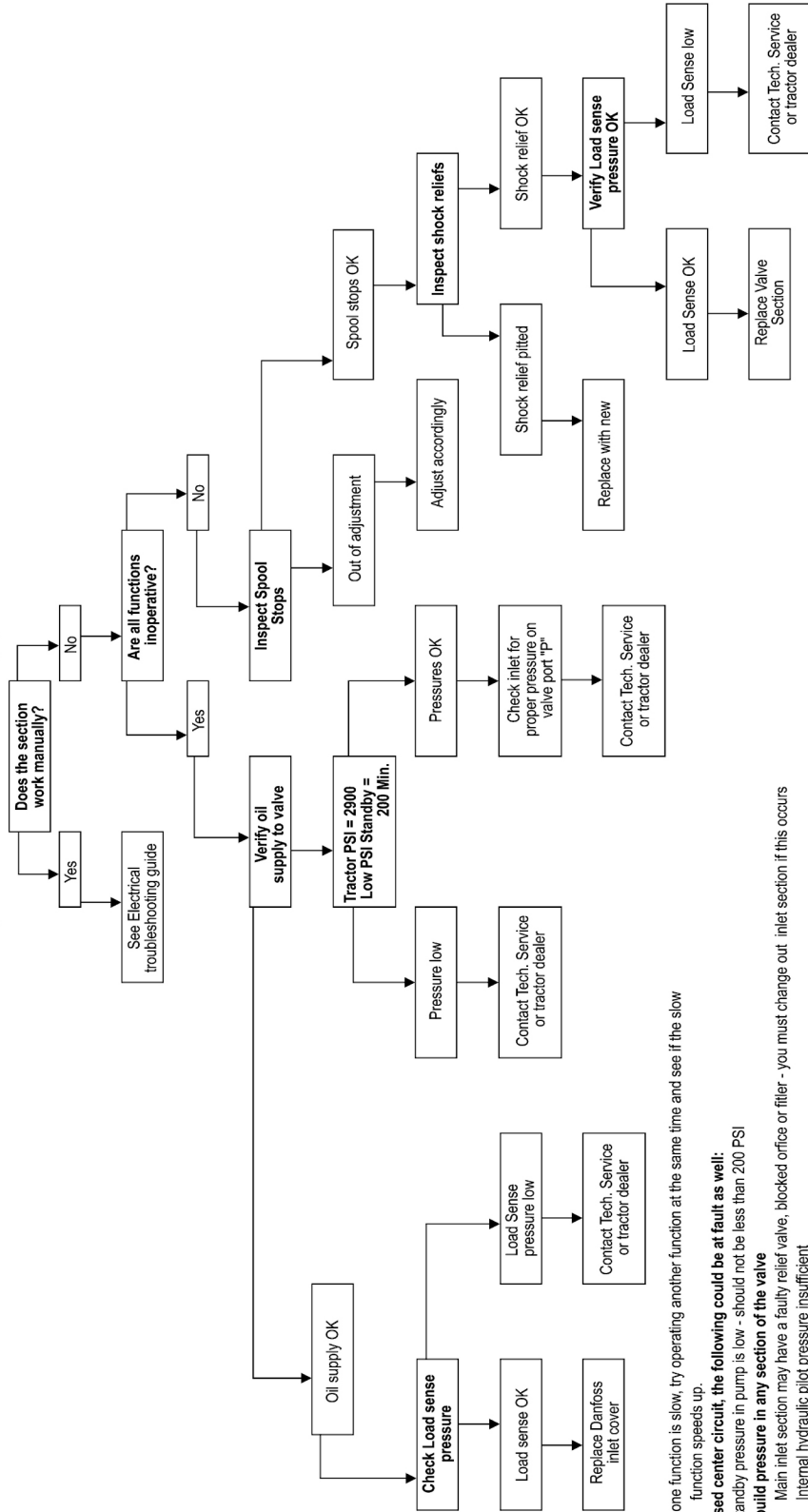

Notes: If one function is slow, try operating another function at the same time and see if the slow function speeds up.

On a closed center circuit, the following could be at fault as well:

Tractor standby pressure in pump is low - should not be less than 200 PSI

Cannot build pressure in any section of the valve

Main inlet section may have a faulty relief valve, blocked orifice or filter - you must change out inlet section if this occurs
Internal hydraulic pilot pressure insufficient

JOYSTICK TROUBLESHOOTING

Boom operation not responding to joystick movement.

Isolate hydraulic vs. electronic symptom.

Turn off electronic master switch (preventing electronic actuator on valve from attempting to hold spool in neutral position). With tractor engine running, operate the valve section with the manual handle. If function operates normally, continue with electronic inspection. If function does not operate normally, continue with hydraulic inspection.

Electronic inspection.

Connect a voltmeter to the cable connector of the valve section that is not operating. This will allow you to measure supply and signal voltage when the joystick is operated.

Main, Secondary, and Swivel Valves – signal voltage should be 50% of supply voltage with joystick in Neutral position, up to 75% of supply voltage in B direction, down to 25% of supply voltage in A direction. Signal voltage should change smoothly with lever movement.

Pin #1 – Signal Voltage, Pin #4 – Power Voltage, Pin #3 – Ground

Deck Roll Valve or Float Valve – signal voltage should be 50% of supply voltage with joystick in Neutral position, up to 65% of supply voltage in B direction, down to 35% of supply voltage in A direction. Signal voltage should change smoothly with lever movement. Signal voltage should be approximately 75% of supply voltage when float switch is operated.

Pin #1 – Signal Voltage, Pin #4 – Power Voltage, Pin #3 – Ground

Shield Valve or On/Off Valve – Voltage on pin #1 should be equal to supply voltage when switch is operated in A direction. Voltage on pin #4 should be equal to supply voltage when switch is operated in B direction.

Pin #1 – Signal Voltage (Shield Open), Pin #4 – Signal Voltage (Shield Close), Pin #3 – Ground

If none of the valve will operate with electrical signal, verify that there is oil pressure at the valve inlet. Electrical Valves must have pilot supply oil to move the spools.

Possible electronic problems.

Open circuit (broken wire, bad connection or loose connection in switchbox).

Shorted to positive, ground, or other.

Incorrect voltage signal from joystick.

Continued on next sheet

TROUBLESHOOTING - CONTINUED

Hydraulic inspection.

Install 3 pressure gauges, on the valve inlet (use M port, or tee into hose supplying oil from the pump to the inlet), on the workport that is not operating, and on the LS port.

With the spools in Neutral

Gear pump – P should be approximately 200 psi, LS = 0, workport – pressure on cylinder or function.

LS pump – P should equal pump standby pressure, LS = 0, workport – pressure on cylinder or function.

Pressure Comp pump – P should equal pump standby pressure, LS = 0, workport – pressure on cylinder or function.

Gear pump – P should be approximately 200 psi higher than LS, LS should equal workport, workport – pressure on cylinder or function.

LS pump – P should be LS + standby, LS should equal workport, workport – pressure on cylinder or function.

Pressure Comp pump – P should equal pump standby pressure, LS should equal workport, workport – pressure on cylinder or function.

Operate one spool, measure pressures with function at end of travel or stop

Gear pump – P should equal valve relief setting or workport shock valve setting. LS should equal workport. Workport should equal relief setting or workport shock valve setting.

LS pump – P should equal valve relief setting, pump max pressure setting, or workport shock valve setting. LS should equal workport. Workport should equal relief setting, pump max pressure setting, or workport shock valve setting.

Pressure Comp pump – P should equal pump standby pressure, LS should equal workport. Workport should equal pump standby pressure or workport shock valve setting.

Operate more than one spool.

Gear pump – P should approximately 200 psi higher than LS. LS should equal highest workport pressure. Workport – pressure on cylinder or function.

LS pump – P should be LS + standby pressure. LS should equal highest workport pressure. Workport – pressure on cylinder or function.

Pressure Comp pump. P should equal pump standby pressure. LS should equal highest workport pressure. Workport – pressure on cylinder or function.

Possible hydraulic problems.

Cylinder leak.

LS signal leaking to tank before reaching pump LS port.

Hydraulic system or pump not supplying flow to valve.

WHEEL WEIGHT - BENGAL 18

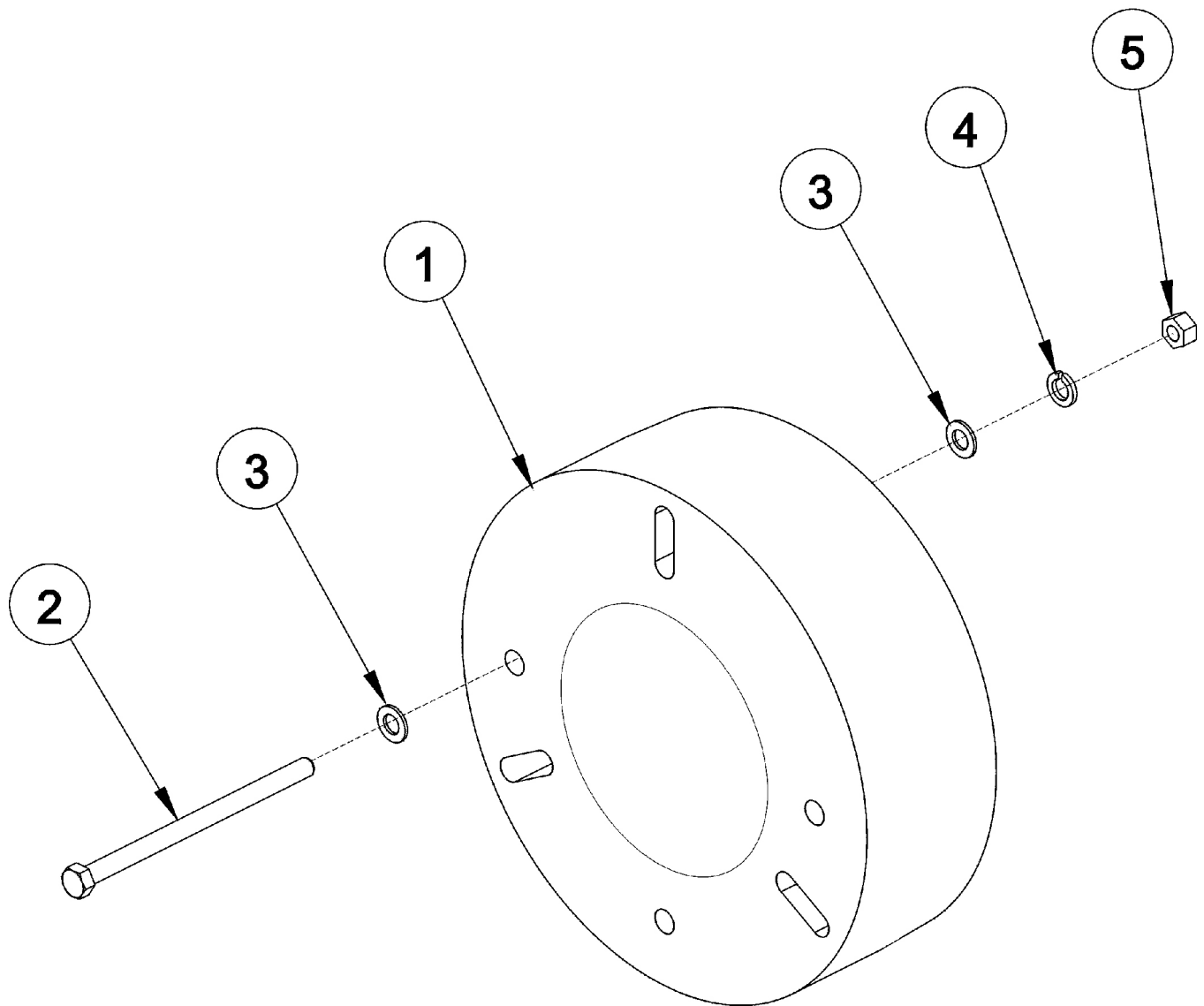

| ITEM | PART NO. | QTY. | DESCRIPTION |
|------|----------|------|------------------------|
| 1 | 30687 | 1 | 500# WHEEL WEIGHT |
| 2 | 21956 | 4 | CAPSCREW,3/4" X 13",NC |
| 3 | 22021 | 8 | FLATWASHER,3/4" |
| 4 | 21993 | 4 | LOCKWASHER,3/4" |
| 5 | 21825 | 4 | HEX NUT,3/4",NC |

COMMON BENGAL T4



TIGER CORPORATION
WARRANTY INFORMATION

Tiger Corporation, 3301 N. Louise, Sioux Falls, South Dakota, warrants to the original Retail Customer, the new Tiger equipment is free of defects in material and workmanship. Any part of said equipment that in Tiger's adjustment, show evidence of such defects will be repaired or replaced without charge, provided that the failure of part(s) shall have occurred within twelve (12) months from the date of delivery of said equipment to the Retail Customer. Expendable components such as knives, oil, chain sprockets, skid shoes, knife mounting disks and the like are excluded but not limited to this warranty.

The Retail Customer must pay the transportation cost to and from the Tiger Dealer's service shop for warranty service. Warranty service will be performed by the Tiger Dealer from whom the equipment was purchased, in his service shop and during his regularly scheduled days and hours of operation.

All Tiger obligation under this warranty shall be terminated if the equipment is modified or altered in ways not approved in writing by Tiger, if repair parts other than genuine Tiger repair parts have been used, or if the equipment has been subject to misuse, neglect, accident, improper maintenance or improper operation.

Tiger Corporation reserves the right to make improvements in design or changes in specification at any time without incurring any obligation to owners of equipment previously sold.

No agent or person has authority to alter, add to or waive the above warranties which are agreed to be in the only warranties, representations or promises, expressed or implied, as to the quality or performance of the products covered and which do not include any implied warranty of merchantability or fitness. In no event will Tiger be liable for incidental or consequential damages or injuries, including, but not limited to, loss of profits, rental or substitute equipment or other commercial loss.

**THERE ARE NO WARRANTIES WHICH EXTEND
BEYOND THOSE EXPRESSED HEREIN.**

It is the Purchasers obligation to sign the warranty registration form **AFTER** he / she has Read and Understands the Operation and Safety Instructions stated within this manual.

ONE LAST WORD

This manual cannot possibly cover all of the potentially hazardous situations you will encounter. By being familiar, though, with the safety rules, operating and maintenance instructions in this manual you can help prevent accidents. The objective of this manual is to help make you a better operator. Remember, **SAFETY IS YOU!**



Your safety and the safety of those around you depends on **YOU**. Common sense should play a large role in the operation of this machine.

Since we at Tiger Corporation are constantly striving to improve our products, we reserve the right to change specifications or design at any time.

