

IM974

B284 / B324
BX324 / BX364

VERGE MOWER

INSTRUCTION MANUAL
(Edition for use in the USA & Canada)

ISSUE 2

IMPORTANT

NOTE HERE THE SERIAL NUMBER OF YOUR MACHINE AND ALWAYS QUOTE IT IN ANY COMMUNICATION WITH US OR YOUR DEALER. THIS IS PARTICULARLY IMPORTANT WHEN ORDERING SPARES. REMEMBER TO INCLUDE ALL NUMBERS AND LETTERS.

MACHINE SERIAL NUMBERS _____

THE INFORMATION GIVEN THROUGHOUT THIS MANUAL IS CORRECT AT THE TIME OF PUBLICATION. HOWEVER, IN THE COURSE OF CONSTANT DEVELOPMENT OF BOMFORD TURNER MACHINES, CHANGES IN SPECIFICATION ARE INEVITABLE. SHOULD YOU FIND THE INFORMATION GIVEN IN THIS BOOK TO BE AT VARIANCE WITH THE MACHINE IN YOUR POSSESSION, YOU ARE ADVISED TO CONTACT THE BOMFORD TURNER SERVICE DEPARTMENT WHERE UP-TO-DATE INFORMATION WILL BE PROVIDED.

THE MANUAL CAN CONTAIN STANDARD AND OPTIONAL FEATURES AND IS NOT TO BE USED AS A MACHINE SPECIFICATION.

THE MACHINE HAS BEEN TESTED AND IS CONSIDERED SAFE IF CAREFULLY USED. ENSURE YOUR OPERATOR IS PROPERLY TRAINED IN ITS USE AND MAINTENANCE.

IMPORTANT

NOTEZ ICI LES NUMEROS DE SERIE DE VOTRE MACHINE ET MENTIONNEZ LES DANS TOUTE COMMUNICATION AVEC NOS SERVICES OU VOTRE REVENDEUR. CECI EST IMPORTANT POUR LA COMMANDE DE PIECES DETACHEES. PENSEZ A NOTER TOUS LES NUMEROS ET TOUTES LES LETTERS.

NUMEROS DE SERIE DE LA MACHINE _____

LES INFORMATIONS DONNEES DANS CE MANUEL SONT CORRECTES CEPENDANT, DU FAIT DE DEVELOPPEMENT CONSTANT DES MACHINES BOMFORD TURNER.

CHANGEMENTS DANS LES CARACTERISTIQUES SONT INEVITABLES.

SI VOUS TROUVEZ QUE LES INFORMATIONS DONNEES NE CORRESPONDENT PAS A VOTRE MACHINE VEUILLEZ CONTACTER LE SERVICE DES REPARATIONS OU DES INFORMATIONS PLUS RECENTES VOUS SERONT DONNEES.

CE MANUEL PEUT MONTRER DES CARACTERISTIQUES OPTIONNELLES ET NE PEUT PAS ETRE CONSIDERE COMME SPECIFICATION DE LA MACHINE.

CETTE MACHINE A ETE TESTEE, ET ELLE EST CONSIDEREE COMME FIABLE A CONDITION D'UNE BONNE UTILISATION. ASSUREZ-VOUS QUE VOTRE OPERATEUR EST QUALIFIE EN CE QUI CONCERNE L'UTILISATION DE LA MACHINE AINSI QUE SON ENTRETIEN.

WICHTIG

TRAGEN SIE HIER DIE SERIENNUMMERN IHRER MASCHINE EIN UND GEBEN SIE DIESE IMMER AN, WENN SIE SICH AN UNS ODER IHREN HÄNDLER WENDEN. DAS IST BESONDERS BEI ERSATZTEILBESTELLUNGEN WICHTIG. VERGESSEN SIE NICHT, ALLE ZAHLEN UND BUCHSTABEN ZU NOTIEREN.

SERIENNUMMERN DER MASCHINE _____

DIE ANGABEN IN DIESEM HANDBUCH SIND BEI VERÖFFENTLICHUNG KORREKT. AUFGRUND DER KONSTANTEN WEITERENTWICKLUNG VON BOMFORD TURNER MASCHINEN SIND JEDOCHÄNDERUGDEN IN DER SPEZIFIKATION UNVERMEIDLICH. WENN DIE INFORMATION IN DIESEM HANDBUCH NICHT MIT IHRER MASCHINE ÜBEREINSTIMMEN, NEHMEN SIE BITTE KONTAKT MIT DER BOMFORD TURNER KUNDENDIENSTABTEILUNG AUF, DIE IHNEN GERNE DIE AKTUELLEN INFORMATION ZUKOMMEN LÄSST.

DAS HANDBUCH KANN SOWOHL BESCHREIBUNGEN FÜR DIE STANDARD AUSFÜHRUNG ALS AUCH FÜR ZUBEHÖR ENTHALTEN UND IST NICHT ALS MASCHINENSPEZIFIKATION ZU VERWENDET.

DIE MASCHINE IST GETESTET UND BEI SACHGEMÄSSEM BETRIEB ALS SICHER BEFUNDEN WORDEN. SORGEN SIE DAFÜR, DASS IHR BEDIENPERSONAL IN ANWENDUNG UND WARTUNG RICHTIG GESCHULT WIRD.

***THIS HANDBOOK COVERS THE OPERATION AND SERVICING
OF THE B284/B324/BX324/BX364 VERGE MOWERS***

Section	Page No.
1. INDEX	1
2. TECHNICAL DATA	2 - 1 TO 2 - 2
3. GENERAL ARRANGEMENT	3 - 1
4. SAFETY PRECAUTIONS	4 - 1 TO 4 - 2
5. TRACTOR REQUIREMENTS	5 - 1
6. INSTALLATION PROCEDURE	6 - 1
7. INITIAL MACHINE PROCEDURE	7 - 1
8. GUARDS AND ROTATION	8 - 1
9. GENERAL OPERATION	9 - 1 TO 9 - 2
10. MAINTENANCE	10-1 TO 10-4
11. REMOVAL AND STORAGE	11-1

IMPORTANT

**THIS MACHINE IS FOR VEGETATION CONTROL AND
MUST NOT BE USED FOR ANY OTHER PURPOSE**

**IT IS POTENTIALLY HAZARDOUS TO FIT OR USE
ANY PARTS OTHER THAN GENUINE BOMFORD TURNER PARTS**

**THE COMPANY DISCLAIMS ALL LIABILITY FOR THE
CONSEQUENCES OF SUCH USE, WHICH IN ADDITION
VOIDS THE MACHINE WARRANTY**

The B284/B324/BX324/BX364 are linkage-mounted offset verge mowers. Drive is provided by the tractor PTO shaft through vee belts and gearbox. The flail head is offset from the mainframe and hydraulic controls provide on-the-move adjustment of the offset and cowl angle.

The machines are designed for on the ground vegetation control and may be used for cutting verges and banks within the scope of their reach and performance.

It is essential the machines are fitted and operated in accordance with this manual.

TECHNICAL DATA

Machine details	B284	B324	BX324	BX364
Maximum reach - ground level fully offset	2835mm	3235mm	3235mm	3635mm
Maximum offset - hydraulically operated	750mm	750mm	750mm	750mm
Transport width	←	Within tractor	width	→
Machine weight (complete)	500kg	570kg	800kg	830kg
Rotor Unit				
Cutting width	1200mm	1600mm	1600mm	2000mm
Cowl size	Medium	Medium	Large	Large
Shaft type	Tubular 4 ½ o.d.	Tubular 4½ o.d.	Tubular 5½ o.d.	Tubular 5½ o.d.
Shaft speed @ 1000 rev/min PTO	2160 rev/min	2160 rev/min	2160 rev/min	2160 rev/min
Optional @ 540 rev/min PTO	2250 rev/min	2250 rev/min	2250 rev/min	2250 rev/min
Tip speed m/s @ 1000	43	43	54	54
Tip speed m/s @ 540	45	45	55	55
Number of Flails	32	44	44	54

NOISE

The equivalent daily personal noise exposure from this machine, measured at the operator's ear, is within the range 80-85dB when used in conditions where the load fluctuates between zero and maximum.

This applies when the machine is attached to a tractor fitted with a quiet cab and used in accordance with the operating instructions in a generally open environment.

At equivalent daily noise exposure levels of between 85 and 90dB suitable ear protectors are recommended.

EC DECLARATION OF CONFORMITY
Conforming to EU Directive 2006/42/EC

We,

Of BOMFORD TURNER LIMITED, Station Road, Salford Priors, Evesham, Worcestershire, WR11 8SW, UK.

Declare that under our sole responsibility the product (type);

Linkage mounted unit	Product code
B284	B323
B324, BX324	B323
BX364	B363

A tractor linkage mounted, vegetation control flail mowing attachment.

Serial No(s). & Date:.....

Designed by: BOMFORD TURNER LTD, Salford Priors, Evesham, Worcestershire, WR11 8SW, UK.

Manufactured by: ALAMO MANUFACTURING SERVICES (UK) Limited, Station Road, Salford Priors, Evesham, Worcestershire, WR11 8SW, UK.

Complies with the required provisions of;

- Directive 2006/42/EC
- Directive 2004/108/EC
- BS EN ISO 12100:2010

And other national standards associated with its design and construction as listed in the technical file.

BOMFORD TURNER LIMITED operates an ISO 9001:2008 quality management system.
This system is accredited by;

BSI, Beech House, Linford Wood, Milton Keynes, UK, MK14 6ES
BSI identification number: UKAS 003
Bomford Turner certificate number: FM 34659

Signed.....
On behalf of BOMFORD TURNER LIMITED Responsible person

Status: Managing Director

Date: 02/01/10

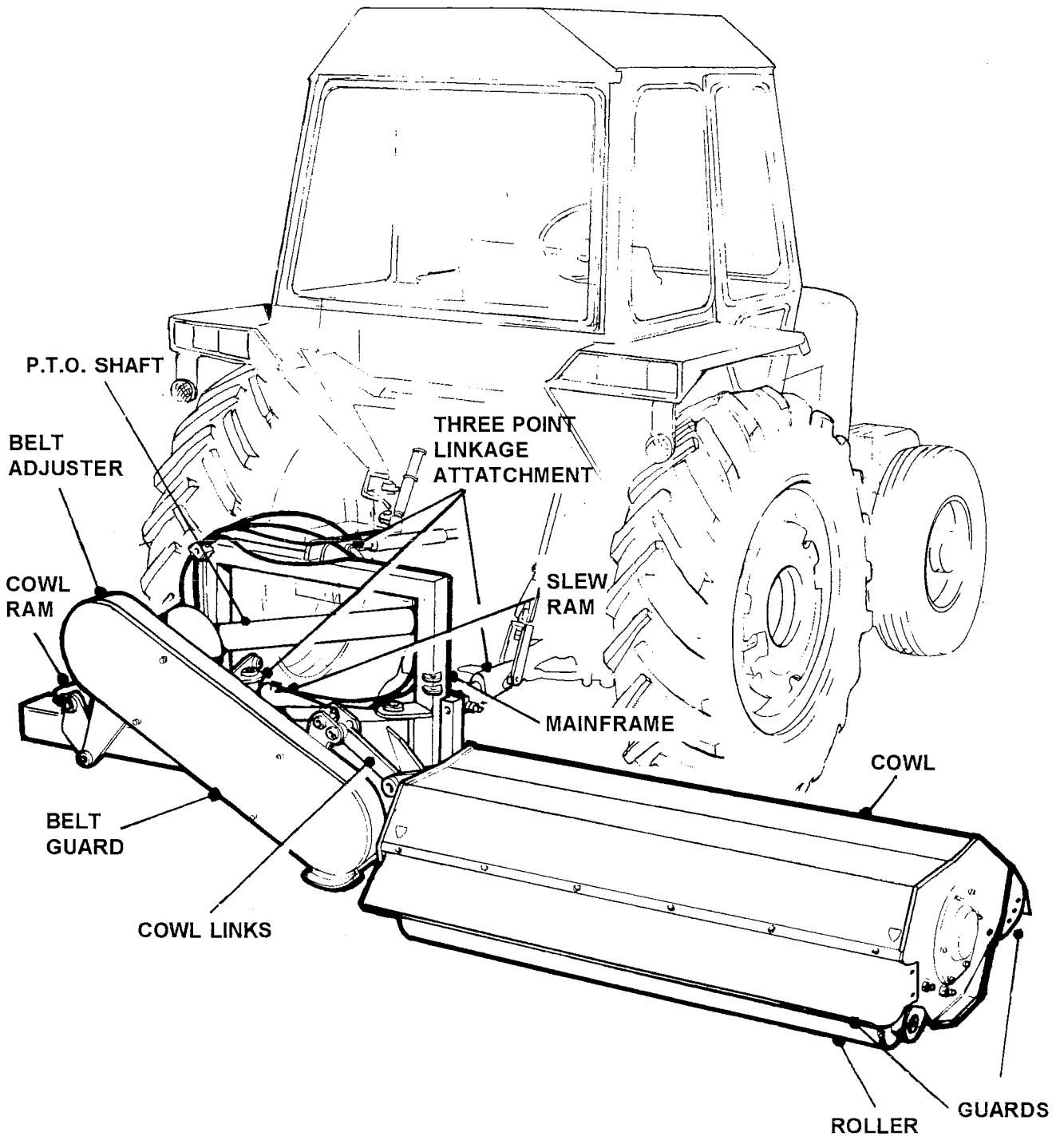

Safety

A safe and careful operator is the best operator. Safety is of primary importance to the manufacturer and should be to the owner/operator. Most accidents can be avoided by being aware of your equipment, your surroundings, and observing certain precautions. The first section of this manual includes a list of Safety Messages that, if followed, will help protect the operator and bystanders from injury or death. Read and understand these Safety Messages before assembling, operating or servicing this implement. This equipment should only be operated by those persons who have read the Manual, who are responsible and trained, and who know how to do so safely and responsibly.

The Safety Alert Symbol combined with a Signal Word, as seen below, is used throughout this manual. The Safety Alert Symbol means: "ATTENTION! BECOME ALERT! YOUR SAFETY IS INVOLVED!" The Symbol and Signal Word are intended to warn the owner/operator of impending hazards and the degree of possible injury faced when operating this equipment.

Practice all usual and customary safe working precautions and above all remember safety is up to YOU. Only YOU can prevent serious injury or death from unsafe practices

CAUTION! **The lowest level of Safety Message; warns of possible injury.**



WARNING! **Serious injury or possible death.**



DANGER! **Imminent death/critical injury.**



(SG-1)

READ, UNDERSTAND, and FOLLOW the following Safety Messages. Serious injury or death may occur unless care is taken to follow the warnings and instructions stated in the Safety Messages. Always use good common sense to avoid hazards.

(SG-2)



Safety (Continued)

PELIGRO!

Si no lee Ingles, pida ayuda a alguien que si lo lea para que le traduzca las medidas de seguridad.



(SG-3)



!LEA EL INSTRUCTIVO!

DANGER!

Never operate the Tractor or Implement until you have read and completely understand this Manual, the Tractor Operator's Manual, and each of the Safety Messages found in the Manual or on the Tractor and Implement. Learn how to stop the tractor engine suddenly in an emergency. Never allow inexperienced or untrained personnel to operate the Tractor and Implement without supervision. Make sure the operator has fully read and understood the manuals prior to operation.



(SG-4)

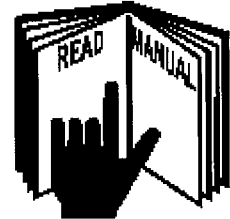

WARNING!

Always maintain the safety decals in good readable condition. If the decals are missing, damaged, or unreadable, obtain and install replacement decals immediately.



(SG-5)

WARNING!

Make certain that the "Slow Moving Vehicle" (SMV) sign is installed in such a way as to be clearly visible and legible. When transporting the Equipment use the Tractor flashing warning lights and follow all local traffic regulations.



(SG-6)

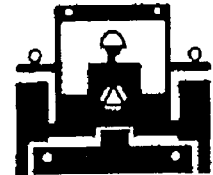

WARNING!

Operate this Equipment only with a Tractor equipped with an approved roll-over-protective system (ROPS). Always wear seat belts. Serious injury or even death could result from falling off the tractor--particularly during a turnover when the operator could be pinned under the ROPS.



(SG-7)



WARNING!

Do not modify or alter this Implement. Do not permit anyone to modify or alter this Implement, any of its components or any Implement function.



(SG-8)

DANGER!

BEFORE leaving the tractor seat, always engage the brake and/or set the tractor transmission in parking gear, disengage the PTO, stop the engine, remove the key, and wait for all moving parts to stop. Place the tractor shift lever into a low range or parking gear to prevent the tractor from rolling. Never dismount a Tractor that is moving or while the engine is running. Operate the Tractor controls from the tractor seat only.



(SG-9)

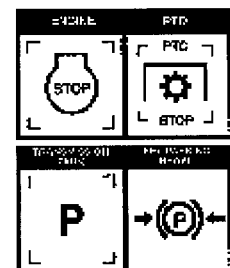

Safety (Continued)

DANGER!

Never allow children or other persons to ride on the Tractor or Implement. Falling off can result in serious injury or death.

(SG-10)



DANGER!

Never allow children to operate or ride on the Tractor or Implement.

(SG-11)



WARNING!

Do not mount the Tractor while the tractor is moving. Mount the Tractor only when the Tractor and all moving parts are completely stopped.

(SG-12)



DANGER!

Start tractor only when properly seated in the Tractor seat. Starting a tractor in gear can result in injury or death. Read the Tractor operators manual for proper starting instructions.

(SG-13)



DANGER!

Never work under the Implement, the framework, or any lifted component unless the Implement is securely supported or blocked up to prevent sudden or inadvertent falling which could cause serious injury or even death.

(SG-14)



DANGER!

Do not operate this Equipment with hydraulic oil leaking. Oil is expensive and its presence could present a hazard. Do not check for leaks with your hand! Use a piece of heavy paper or cardboard. High-pressure oil streams from breaks in the line could penetrate the skin and cause tissue damage including gangrene. If oil does penetrate the skin, have the injury treated immediately by a physician knowledgeable and skilled in this procedure.

(SG-15)

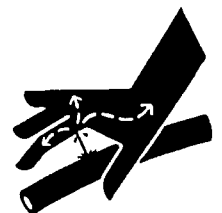

Safety (Continued)

WARNING!



The operator and all support personnel should wear hard hats, safety shoes, safety glasses, and proper hearing protection at all times for protection from injury including injury from items thrown by the equipment

(SG-16)

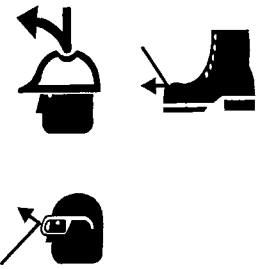

CAUTION!



PROLONGED EXPOSURE TO LOUD NOISE MAY CAUSE PERMANENT HEARING LOSS! Tractors with or without an Implement attached can often be noisy enough to cause permanent hearing loss. We recommend that you always wear hearing protection if the noise in the Operator's position exceeds 80db. Noise over 85db over an extended period of time will cause severe hearing loss. Noise over 90db adjacent to the Operator over an extended period of time will cause permanent or total hearing loss. *Note:* Hearing loss from loud noise [from tractors, chain saws, radios, and other such sources close to the ear] is cumulative over a lifetime without hope of natural recovery.

(SG-17)

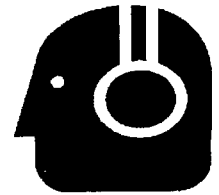

WARNING!



Transport only at safe speeds. Serious accidents and injuries can result from operating this equipment at unsafe speeds. Understand the Tractor and Implement and how it handles before transporting on streets and highways. Make sure the Tractor steering and brakes are in good condition and operate properly.



Before transporting the Tractor and Implement, determine the safe transport speeds for you and the equipment. Make sure you abide by the following rules:

1 - Test the tractor at a slow speed and increase the speed slowly. Apply the Brakes smoothly to determine the stopping characteristics of the Tractor and Implement. As you increase the speed of the Tractor the stopping distance increases. Determine the maximum safe transport speed for you and this Equipment.

2 -Test the equipment at a slow speed in turns. Increase the speed through the turn only after you determine that it is safe to operate at a higher speed. Use extreme care and reduce your speed when turning sharply to prevent the tractor and implement from turning over. Determine the maximum safe turning speed for you and this equipment before operating on roads or uneven ground.

3 – Only transport the Tractor and Implement at the speeds that you have determined are safe and which allow you to properly control the equipment.

Be aware of the operating conditions. Do not operate the Tractor with weak or faulty brakes. When operating down a hill or on wet or rain slick roads, the braking distance increases: use extreme care and reduce your speed. When operating in traffic always use the Tractor's flashing warning lights and reduce your speed. Be aware of traffic around you and watch out for other people.



SG-19

Safety (Continued)

WARNING! Never attempt to lubricate, adjust, or remove material from the Implement while it is in motion or while tractor engine is running. Make sure the tractor engine is off before working on the Implement.



SG-20

WARNING! Always read carefully and comply fully with the manufacturers instructions when handling oil, solvents, cleansers, and any other chemical agent.



SG-22



WARNING! Periodically inspect all moving parts for wear and replace when necessary with authorised service parts. Look for loose fasteners, worn or broken parts, and leaky or loose fittings. Make sure all pins have cotter pins and washers. Serious injury may occur from not maintaining this machine in good working order.



SG21

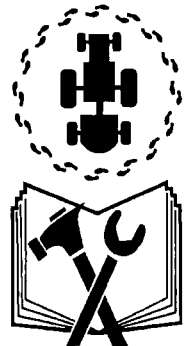

DANGER! Never run the tractor engine in a closed building or without adequate ventilation. The exhaust fumes can be hazardous to your health.



SG-23

DANGER! KEEP AWAY FROM ROTATING ELEMENTS to prevent entanglement and possible serious injury or death.



SG-24



DANGER! Never allow children to play on or around Tractor or Implement. Children can slip or fall off the Equipment and be injured or killed. Children can cause the Implement to shift or fall crushing themselves or others.



SG-25

Safety (Continued)

WARNING! Do not exceed the rated PTO speed for the Implement. Excessive PTO speeds can cause Implement driveline or blade failures resulting in serious injury or death.



SG-26

DANGER! **NEVER use drugs or alcohol** immediately before or while operating the Tractor and Implement. Drugs and alcohol will affect an operator's alertness and co-ordination and therefore affect the operator's ability to operate the equipment safely. Before operating the Tractor or Implement, an operator on prescription or over-the-counter medication must consult a medical professional regarding any side effects of the medication that would hinder their ability to operate the Equipment safely. **NEVER** knowingly allow anyone to operate this equipment when their alertness or co-ordination is impaired. Serious injury or death to the operator or others could result if the operator is under the influence of drugs or alcohol.

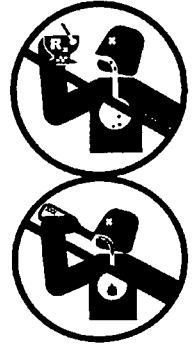

SG-27

DANGER! Operate the Tractor and/or Implement controls only while properly seated in the Tractor seat with the seat belt securely fastened around you. Inadvertent movement of the Tractor or Implement may cause serious injury or death.



SG-29

WARNING! Engine Exhaust, some of its constituents, and certain vehicle components contain or emit chemicals known to the state of California to cause cancer and birth defects or other reproductive harm.



SG-30

WARNING! Battery posts, terminals and related accessories contain lead and lead compounds, chemicals known to the state of California to cause cancer and birth defects or other reproductive harm. Wash Hands after handling.



SG-32

WARNING! Prolonged operation may cause operator boredom and fatigue affecting safe operation. Take scheduled work breaks to help prevent these potentially impaired operating conditions. Never operate the Implement and Tractor in a fatigued or bored mental state that impairs proper and safe operation.



WARNING! Use extreme caution when getting onto the Implement to perform repairs, maintenance and when removing accumulated material. Only stand on solid flat surfaces to ensure good footing. Use a ladder or raised stand to access high areas that cannot be reached from ground level. Slipping and falling can cause serious injury or death.



Safety (Continued)

WARNING! Avoid contact with hot surfaces including hydraulic oil tanks, pumps, motors, valves and hose connections. Relieve hydraulic pressure before performing maintenance or repairs. Use gloves and eye protection when servicing hot components. Contact with a hot surface or fluid can cause serious injury from burns or scalding.



WARNING! Perform service, repairs and lubrication according to the maintenance section. Ensure the unit is properly lubricated as specified in the lubrication schedule and all bolts and nuts are properly tightened to the correct torque. Failure to properly service, repair and maintain this Implement in good operating condition could cause component failure and possible serious injury or even death.



DANGER! DO NOT operate this Implement on a Tractor that is not properly maintained. Should a mechanical or Tractor control failure occur while operating, immediately shut down the Tractor and perform repairs before resuming operation. Serious injury and possible death could occur from not maintaining this Implement and Tractor in good operating condition.



WARNING! Mow only in conditions where you have clear visibility in daylight or with adequate artificial lighting. Never mow in darkness or foggy conditions where you cannot clearly see at least 100 yards in front and to the sides of the tractor and mower. Make sure that you can clearly see and identify passers-by, steep slopes, ditches, drop-offs, overhead obstructions, power lines, debris and foreign objects. If you are unable to clearly see this type of items discontinue mowing.



DANGER! There are obvious and hidden potential hazards in the operation of this Mower. REMEMBER! This machine is often operated in heavy brush and in heavy weeds. The Blades of this Mower can throw objects if shields are not properly installed and maintained. Serious injury or even death may occur unless care is taken to insure the safety of the operator, bystanders, or passers-by in the area. Do not operate this machine with anyone in the immediate area. Stop mowing if anyone is within 100 yards of mower.



DANGER! All Safety Shields, Guards and Safety devices including (but not limited to) - the Deflectors, Chain Guards, Steel Guards, Gearbox Shields, PTO integral shields, and Retractable Door Shields should be used and maintained in good working condition. All safety devices should be inspected carefully at least daily for missing or broken components. Missing, broken, or worn items must be replaced at once to reduce the possibility of injury or death from thrown objects, entanglement, or blade contact.

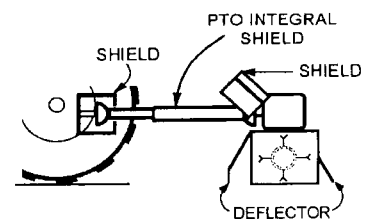

Safety (Continued)

DANGER! The rotating parts of this machine have been designed and tested for rugged use. However, the blades could fail upon impact with heavy, solid objects such as metal guard rails and concrete structures. Such impact could cause the broken objects to be thrown outward at very high velocities. To reduce the possibility of property damage, serious injury or even death, never allow the cutting blades to contact such obstacles.



SGM-4

WARNING! Extreme care should be taken when operating near loose objects such as gravel, rocks, wire, and other debris. Inspect the area before mowing. Foreign objects should be removed from the site to prevent machine damage and/or bodily injury or even death. Any objects that cannot be removed must be clearly marked and carefully avoided by the operator. Stop mowing immediately if blades strike a foreign object. Repair all damage and make certain rotor or blade carrier is balanced before resuming mowing.



SGM-5

WARNING! Many varied objects, such as wire, cable, rope, or chains, can become entangled in the operating parts of the mower head. These items could then swing outside the housing at greater velocities than the blades. Such a situation is extremely hazardous and could result in serious injury or even death. Inspect the cutting area for such objects before mowing. Remove any like object from the site. Never allow the cutting blades to contact such items.



SGM-6

WARNING! Mow at the speed that you can safely operate and control the tractor and mower. Safe mowing speed depends on terrain condition and grass type, density, and height of cut. Normal ground speed range is from 0 to 5 mph. Use slow mowing speeds when operating on or near steep slopes, ditches, drop-offs, overhead obstructions, power lines, or when debris and foreign objects are to be avoided.



SGM-7

WARNING! Avoid mowing in reverse direction when possible. Check to make sure there are no persons behind the mower and use extreme care when mowing in reverse. Mow only at a slow ground speed where you can safely operate and control the tractor and mower. Never mow an area that you have not inspected and removed debris or foreign material.



SGM-8

Safety (Continued)**DANGER!**

Replace bent or broken blade with new blades. NEVER ATTEMPT TO STRAIGHTEN OR WELD ON BLADES SINCE THIS WILL LIKELY CRACK OR OTHERWISE DAMAGE THE BLADE WITH SUBSEQUENT FAILURE AND POSSIBLE SERIOUS INJURY FROM THROWN BLADES.

SGM-10

WARNING!

Do not mow with two machines in the same area except with Cab tractors with the windows closed.

SGM-11

WARNING!

DO NOT weld or repair rotating mower components. Welds and other repairs may cause severe vibration and/or component failure resulting in parts being thrown from the mower causing serious bodily injury. See your Authorized Dealer for proper repairs.

WARNING!

The Mower is designed for certain mowing applications and is rated to cut up to a specific size vegetation (see Mower Standard Equipment and Specifications). DO NOT use this Mower to cut vegetation above the Mower's rated capacity or to cut any type of non-vegetative material. Only operate this Mower on a properly sized and equipped Tractor. Operating this Mower in an application for which it is not designed and/or operating the Mower with the wrong size Tractor can cause Mower component damage and equipment failure resulting in possible serious injury or death.

DANGER!

Always disconnect the main PTO Driveline from the Tractor before performing service on the Mower. Never work on the Mower with the tractor PTO driveline connected and running. Blades or Drivelines could turn without warning and cause immediate entanglement, injury or death.

DANGER!

Do not turn so sharp or lift mower so high to produce a severe "knocking" of the Driveline which will cause accelerated wear and breakage of drive train components and could result Impossible injury from the separated Driveline sections.

DANGER!

Flail Mowers are capable under adverse conditions of throwing objects for great distances (100 yards or more) and causing serious injury or death. Follow safety messages carefully

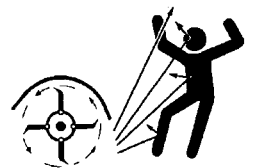
**WARNING!**

Only tow the Implement behind a properly sized and equipped Tractor which exceeds the weight of the Implement by at least 20%. DO NOT tow the Implement behind a truck or other type of vehicle. Never tow the Implement and another Implement connected in tandem. Never tow the Implement at speeds over 20 MPH.

WARNING!

Secure the Implement for transport before travelling on public roads. For pull-type Implements secure the centre axle using cylinder stops or transport pin and properly attach a safety chain between the Implement and Tractor. Secure wings in upright position on folding Implements using wing transport locks.

Safety (Continued)**DANGER!**

Do not operate the implement while wearing loose fitting clothing. Entanglement of the clothing with the rotating elements can result in serious injury or even death. Stay clear of all rotating elements at all times.

DANGER!

All Safety Shields, Guards and other safety devices including (but not limited to) - Deflectors, Steel Guards and Gearbox Shields must be used and maintained in good working condition. All safety devices should be inspected carefully at least daily for missing or broken components. Missing, broken, or worn items must be replaced at once to reduce the possibility of injury or death from thrown objects, entanglement, or blade contact.

WARNING!

Wear gloves and exercise care when handling blades. Blades are SHARP and can cause lacerations to hands and other parts of the body if not safely handled.

WARNING!

Be particularly careful when transporting the Implement with the Tractor. Turn curves or go up hills only at a low speed and using a gradual steering angle. Rear mounted implements move the centre of gravity to the rear and remove weight from the front wheels. Make certain, by adding front ballast, that at least 20% of the tractor's weight is on the front wheels to prevent rearing up, loss of steering control or Tractor tip-over. Slow down on rough or uneven surfaces to prevent loss of steering control that could result in property damage or possible injury. Do not transport unless 3-Point lift lever is fully raised and in the latched transport position. Dropping implement in transport can cause serious damage to the tractor and/or Implement and possibly cause the operator or others to be injured or killed.

DANGER!

A rear Implement can fall if not properly supported. Always use the stand on the front hitch (if equipped) or block up securely to prevent falling and possible crushing injury and/or other injury from holding or lifting heavy components. Use the stand to stabilize the implement during storage.

WARNING!

Use extreme care when lowering or unfolding the implement's wings. Make sure no bystanders are close by or underneath the wings. Allow ample clearance around the implement when folding or unfolding the wings. Use extreme caution around buildings or overhead power lines.

CAUTION!

To prevent tipping of implement when stored in folded position, use carrying wheels or adequate stands on centre frame.

Safety (Continued)**DANGER!**

There are obvious and hidden potential hazards in the operation of this Implement as in all power-driven or pulled equipment. **REMEMBER!** This machine is often operated in rough terrain conditions that include tall grass, weeds, gullies, holes, slopes, hidden obstructions and the like. Serious injury or even death may occur unless care is taken to assure the safety of the operator and bystanders in the area. Do not operate this machine with anyone in the immediate area.

DANGER!

Always disconnect the main PTO Driveline from the Tractor before performing service on the Implement. Never work on the Implement with the tractor PTO driveline connected and running. Rotating Parts, Blades or Drivelines could turn without warning and cause immediate entanglement, injury or death.

DANGER!

This Implement is wider than the Tractor. Be careful when operating or transporting this equipment to prevent the Implement from running into or striking sign posts, guard rails, concrete abutments or other solid objects. Such an impact could cause the Implement and Tractor to pivot violently resulting in loss of steering control, serious injury, or even death. Never allow the Implement to contact obstacles.

WARNING!

DO NOT use a PTO adapter to attach a non-matching Implement driveline to a Tractor PTO. Use of an adapter can double the operating speed of the Mower resulting in excessive vibration, thrown objects, and blade and mower failure. Adapter use will also change the working length of the driveline exposing unshielded driveline areas. Serious bodily injury and/or equipment failure can result from using a PTO adapter. Consult an authorized dealer for assistance if the Implement driveline does not match the Tractor PTO.

DANGER!

Always shut the Tractor completely down, place the transmission in park, and set the parking brake before you or anyone else attempts to connect or disconnect the Implement and Tractor hitches.

WARNING!

When attaching the Implement input driveline to the Tractor PTO, it is important that the connecting yoke spring activated locking collar slides freely and the locking balls are seated securely in the groove on the Tractor PTO shaft. A driveline not attached correctly to the Tractor PTO shaft could come loose and result in personal injury and damage to the Implement.

WARNING!

Before operating the Mower, check to make sure the Implement input driveline will not bottom out or become disengaged. Bottoming out occurs when the inner shaft penetrates the outer housing until the assembly becomes solid - it can shorten no more. Bottoming out can cause serious damage to the Tractor PTO by pushing the PTO into the Tractor and through the support bearings or downward onto the PTO shaft, breaking it off. A broken drive line can cause personal injury.

Safety (Continued)**DANGER!**

Never crawl under a raised Implement supported solely by the Tractor 3-Point hitch. Release of the control lever or mechanical failure will result in the Implement falling and possible injury or death. Always securely block up the Implement before crawling underneath to perform repairs and service.

WARNING!

Allow sufficient clearance for the Implement to swing outward while turning. Implements carried behind the Tractor will swing outside the tire path when making turns. Contacting a solid object while turning will cause equipment damage and possible injury.

DANGER!

Flail Mowers are capable under adverse conditions of throwing objects for great distances (100 yards or more) and causing serious injury or death. Follow safety messages carefully.

STOP MOWING IF PASSERS BY ARE WITHIN 100 YARDS UNLESS:

- Front and Rear Deflectors are installed and in good, working condition;
- Mower Head is running close to and parallel to the ground without exposed Blades;
- Passers by are outside the existing thrown-object zone;
- All areas have been thoroughly inspected and all foreign material such as rocks, cans, glass, and general debris has been removed.

NOTE

Where there are grass and weeds high enough to hide debris that could be struck by the blades, the area should be: inspected and large debris removed, mowed at an intermediate height, inspected closely with any remaining debris removed, and mowed again at desired final height.

SBM-1

DANGER!

Use extreme caution when raising the Mower head. Stop the Blades from turning when the Mower Head is raised and passers by are within 100 yards. Raising the Mower head exposes the Cutting Blades which creates a potentially serious hazard and can cause serious injury by objects thrown from the Blades or by contact with the Blades.

SBM-2

DANGER!

Be particularly careful in transport. The Mower has raised the centre of gravity for the tractor and has increased the possibility of overturn. Turn curves or go up slopes only at low speed and using a gradual turning angle. Slow down on rough or uneven surfaces.

SBM-3



Safety (Continued)

WARNING! Never leave the Tractor and Implement unattended while the Implement is in the lifted position. Accidental operation of lifting lever or a hydraulic failure may cause sudden drop of unit with injury or death by crushing. To properly park the implement when disconnecting it from the tractor, lower the stand and put the retaining pin securely in place, or put a secure support under the A-Frame. Lower the implement carefully to the ground. Do not put hands or feet under lifted components.



Never leave the mower unattended while the head is in the raised position. The mower could fall causing serious injury to anyone who might inadvertently be under the mower

SBM-4

WARNING! The rotating parts of this machine continue to rotate even after the Tractor has been turned off. The operator should remain in his seat for 60 seconds after the brake has been set, the PTO disengaged, the tractor turned off, and all evidence of rotation has ceased.



“Wait a minute...Save a life!”

SBM-5

WARNING! Relieve hydraulic pressure prior to doing any maintenance or repair work on the Implement. Place the Mower Head on the ground or securely supported on blocks or stands, disengage the PTO, and turn off the engine. Push and pull the control Levers or Joystick several times to relieve pressure prior to starting any maintenance or repair work.



SBM-6

DANGER! Always keep a careful lookout and use extreme care when working around overhead obstructions. Never allow the Mower head or boom within 10 feet of any power line. When working close to overhead power lines consult your electric company for a safe code of operation.



SBM-7

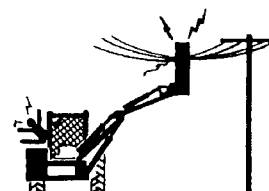

DANGER! When transporting Boom Mower on a truck or trailer, the height or width may exceed legal limits when the boom is in the transport position. Contact with side or overhead structures or power lines can cause property damage or serious injury or death. If necessary lower boom to reduce height and/or remove mowing head to reduce width to the legal limits.



SBM-8

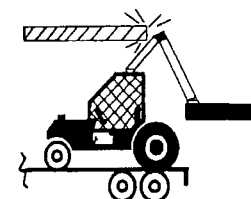

DANGER! Never operate the Tractor and Mower Unit without an OPS (Operators Protective Structure) or Cab to prevent injury from objects thrown from ground or from overhead trimming. Stop mowing if workers or passers by are within 100 yards.



SBM-9

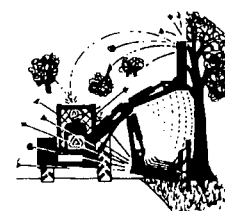

Safety (Continued)

DANGER!



The centre of Gravity of Tractors equipped with a Rear-Mounted Boom Mower is shifted to the rear and removes weight from the front wheels. Add front ballast until at least 20% of the tractors weight is on the front wheels to prevent rearing up, loss of steering control, and possibly injury.

SBM-10

DANGER!



Each Rear Wheel must have a minimum of 1500 pound contact with the surface to prevent lateral instability and possible tip-over which could result in serious bodily injury or even death. Widen the wheel tread and add weights if needed. Refer to the mounting instructions or call Customer Service if you need assistance with Counterweight Procedure.

SBM-11

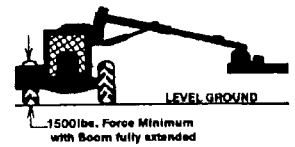

DANGER!



Always disconnect the wire leads from the mower valve solenoid before performing service on the Tractor or Mower. Use caution when working on the Tractor or Mower. Tractor engine must be stopped before working on Mower or Tractor. The Mower Blades could inadvertently be turned on without warning and cause immediate dismemberment, injury or death.

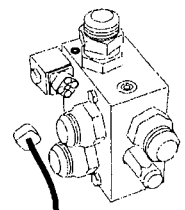

WARNING!



The Joystick Master Control Switch must be OFF to prevent accidental movement of the boom and cutting head whenever the mower is not being operated.

DANGER!



There are obvious and hidden potential hazards in the operation of this Mower. REMEMBER! This machine is often operated in grass and in heavy weeds. The Blades of this Mower can throw objects if shields are not properly installed and maintained. Serious injury or even death may occur unless care is taken to insure the safety of the operator, bystanders, or passers by in the area. Do not operate this machine with anyone in the immediate area. Stop mowing if anyone is within 100 yards of mower.

DANGER!



Do not put hands or feet under mower decks. Blade Contact can result in serious injury or even death. Stay away until all motion has stopped and the decks are securely blocked up.

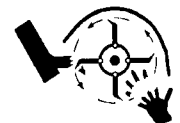

WARNING!

Do not operate Mower if excessive vibration exists. Shut down PTO and the Tractor engine. Inspect the Mower to determine the source of the vibration. If Mower blades are missing or damaged replace them immediately. Do not operate the mower until the blades have been replaced and the Mower operates smoothly. Operating the Mower with excessive vibration can result in component failure and broken objects to be thrown outward at very high velocities. To reduce the possibility of property damage, serious injury or even death never allow the Mower to be operated with blades missing.

Safety (Continued)**DANGER!**

All Safety Shields, Guards and Safety devices including (but not limited to) - the Deflectors, Steel Guards, Gearbox Shields, PTO integral shields and Retractable Door Shields should be used and maintained in good working condition. All safety devices should be inspected carefully at least daily for missing or broken components. Missing, broken, or worn items must be replaced at once to reduce the possibility of injury or death from thrown objects, entanglement, or blade contact.

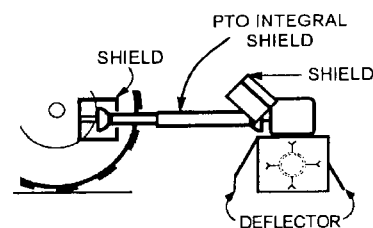
**DANGER!**

Flail Mowers are capable under adverse conditions of throwing objects for great distances (100 yards or more) and causing serious injury or death. Follow safety messages carefully.



STOP MOWING IF PASSERS BY ARE WITHIN 100 YARDS UNLESS:

- Front and Rear Deflectors are installed and in good, working condition;
- Mower Head is running close to and parallel to the ground without exposed

Blades;

- Passers by are outside the existing thrown-object zone;
- All areas have been thoroughly inspected and all foreign material such as rocks, cans, glass, and general debris has been removed.

NOTE

Where there are grass and weeds high enough to hide debris that could be struck by the blades, the area should be: inspected and large debris removed, mowed at an intermediate height, inspected closely with any remaining debris removed, and mowed again at desired final height.

WARNING!

Use caution and wear protective gloves when handling sharp objects such as blades, knives, and other cutting edges. Be alert to worn component surfaces which have sharp edges. Sharp surfaces can inflict severe laceration injuries if proper hand protection is not worn.

SG-37

Safety (Continued)

In addition to the design and configuration of this Implement, including Safety Signs and Safety Equipment, hazard control and accident prevention are dependent upon the awareness, concern, prudence, and proper training of personnel involved in the operation, transport, maintenance, and storage of the machine. Refer also to Safety Messages and operation instruction in each of the appropriate sections of the Tractor and Equipment Manuals. Pay close attention to the Safety Signs affixed to the Tractor and Equipment.

Safety Decals

Safety decals are located at various points of the machine.. They can be identified by the yellow upper panel depicting the hazard and the lower white panel indicating means of avoidance or precautions to be taken. These decals have no text. It is essential that all operators and personnel associated with the machine understand their meanings which are described on the following pages.

PARTS INFORMATION

Bomford Turner mowers use balanced and matched system components for blade carriers, blades, cutter shafts, knives, knife hangers, rollers, drive train components, and bearings. These parts are made and tested to Bomford Turner specifications. Non-genuine "will fit" parts do not consistently meet these specifications. The use of "will fit" parts may reduce mower performance, void mower warranties, and present a safety hazard. Use genuine Bomford Turner mower parts for economy and safety.

SEE YOUR BOMFORD TURNER DEALER

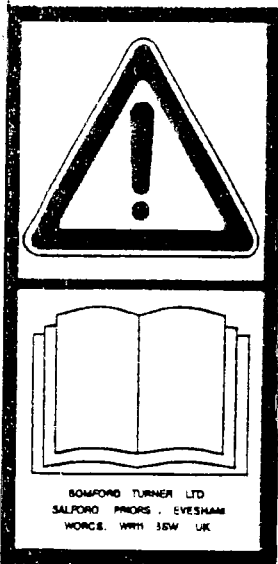

READ THE INSTRUCTION MANUAL BEFORE STARTING WORK

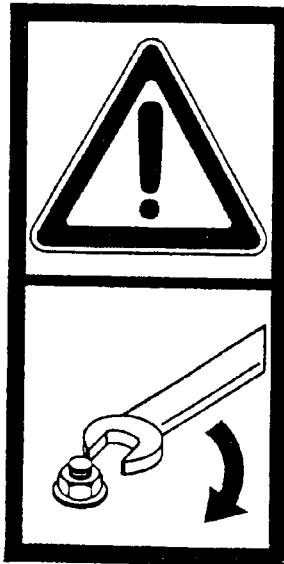

KEEP ALL NUTS TIGHT

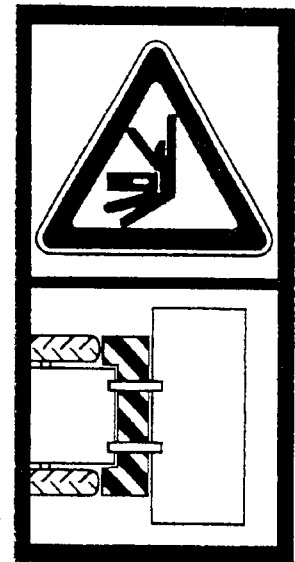

DANGER OF CRUSHING STAY CLEAR OF ZONES



DO NOT WORK UNDER OR STAND UNDER UNSUPPORTED MACHINE



DANGER FROM THROWN DEBRIS KEEP ALL PERSONNEL AT SAFE DISTANCE FROM THE MACHINE WHEN WORKING

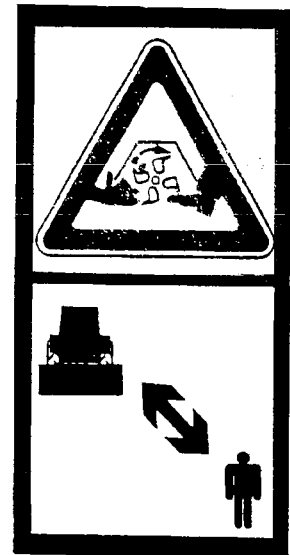

DANGER OF ROTATING BLADES STAY CLEAR OF OPERATING MACHINE



DANGER OF ENTANGLEMENT IN SHAFT KEEP ALL PERSONNEL CLEAR WHILE TRACTOR IS RUNNING

STOP TRACTOR AND REMOVE KEY BEFORE ATTEMPTING MAINTENANCE ON OR UNBLOCKING HEAD

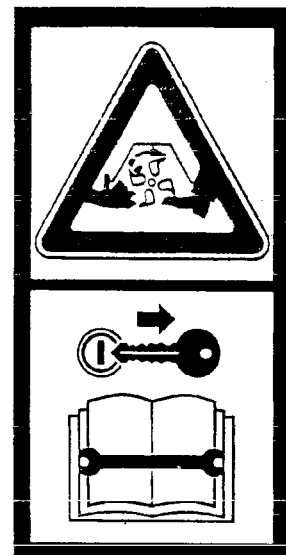

1 TRACTOR REQUIREMENTS

Ensure the specifications of the tractor meet the requirements listed below:

- a A PTO output of 1000 rev/min. (Optional 540 rev/min).
- b A Cat II three point linkage.
- c Adjustable top link.
- d Ballasted weight of tractor should exceed 2000kg (4400 lb) for B284 and B324 models and 2500kg for BX models
- e Adequate ballast should be added to the rear wheel opposite to the arm and front of the tractor to ensure stability .

MACHINES USING TRACTOR SPOOL VALVE

Ensure that the spool valve can provide:

- a Flow 22-45 lit/min (5-10 gal/min).
- b Minimum pressure 125 bar (2200 lbf/in).
- c Two spools, both double acting.

2 MACHINE PREPARATION

- a The machine will normally be delivered fully assembled either standing on the mainframe with the cowl vertical (A), or with the cowl on the ground and mainframe vertical (B).
- b The lifting points are for machines fitted with transit stay. When lifting in anything other than this condition extreme care should be exercised as the centre of gravity may change
- c Only personnel experienced in lift and hoist operation should attempt repositioning the machine.
- d If supplied in position (B) the machine must be craned into position (A). The machine to remain supported on the crane until attached to the tractor.

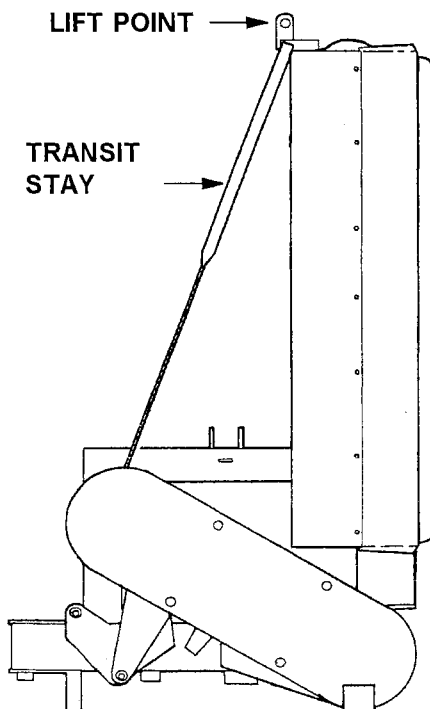

'B' TYPE MACHINES

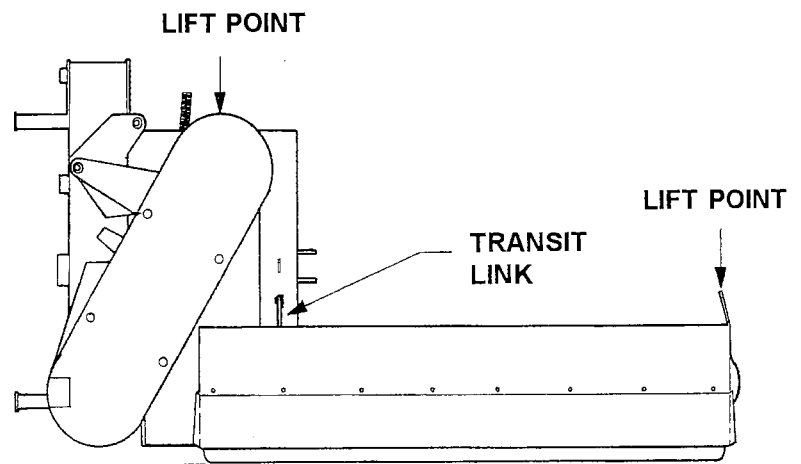

'BX' TYPE MACHINES

1 FITTING TO TRACTOR

IMPORTANT

COWL RAM MUST BE BLED BEFORE THE STAY SUPPORTING THE COWL IS REMOVED. FAILURE TO BLEED RAM WILL RESULT IN THE COWL CRASHING TO THE GROUND.

(See Section 6 on page 6-3)

- a Position the machine on a flat, hard surface
- b Reverse tractor squarely to the machine
- c Carefully reverse the tractor so that the ball joints on the linkage line up with the clevis on the mainframe 3 (A).
- d Position left lift arm 3(B) in mounting clevis 3(C), fit pin and lock with linch pin and ring.
- e Adjust right lift arm 3(D) if necessary.
- f Position right lift arm 3(D) in mounting clevis 3(E), fit pin and lock with linch pin and ring.
- g Fit adjustable top link 3(F) between tractor and top of mainframe.
- h Secure with pin provided with tractor.
- i Lift the machine hydraulically until the stands are clear of the ground. Adjust the right arm and the top link until the machine is square with the tractor.
- j Raise stands 3(G) and store by putting the locking pin in the bottom hole of the stand.
- k Fit the tractor external check chains to the lift arms and adjust until there is no sideways movement.

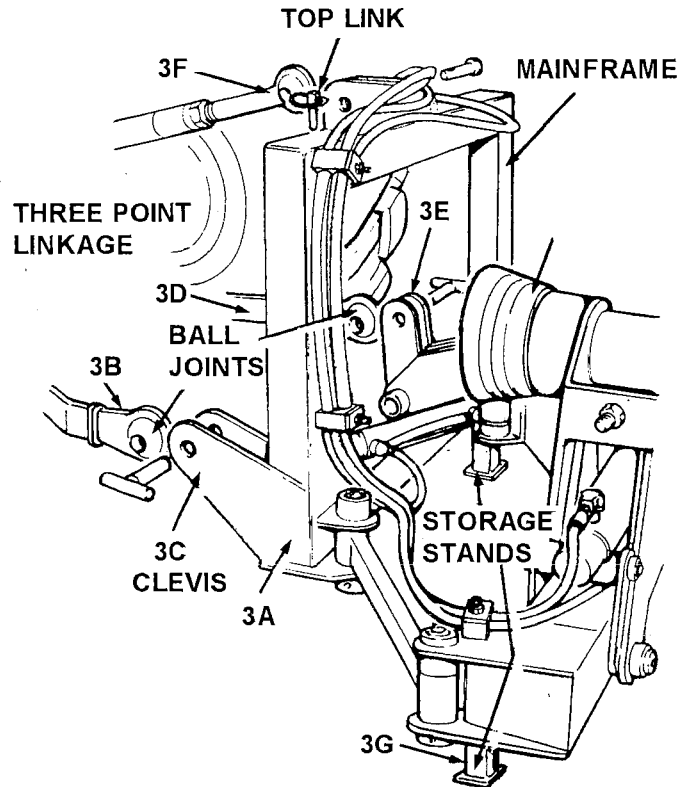

2 FITTING PTO

Due to the many different makes and sizes of tractor to which BOMFORD TURNER mowers can be fitted, a nominal length PTO shaft is supplied with the machine. In some cases it may be found that this PTO shaft is too long and will have to be shortened.

IMPORTANT

MINIMUM ENGAGEMENT OF THE PTO SQUARE DRIVE IS 100MM (4") AND 150MM (6") FOR THE LEMON TUBE TYPE IN THE WORKING POSITION. THIS MEASUREMENT MUST BE TAKEN INTO ACCOUNT WHEN SHORTENING THE PTO SHAFT. MINIMUM ENGAGEMENT OF THE PTO MUST BE CHECKED THROUGHOUT THE RANGE OF OFFSET.

Before fitting the PTO shaft to the tractor, grease the sliding drive shafts and bearing units.

- a Fit PTO to tractor ensuring locking peg on the splined coupling is fully engaged.
- b Attach PTO guard check chains to the tractor and machine

3 CONNECTING THE HYDRAULICS

(A) MACHINES USING TRACTOR SPOOL VALVE

Connect the four hydraulic hoses to the spool valve fittings. To establish the position and type of fitting refer to the tractor instruction manual IF IN DOUBT CONSULT YOUR LOCAL DEALER.

(B) MACHINES USING MAINFRAME SPOOL VALVE

Alternative kits are available for:

- a Open centre hydraulics. This kit includes parts so that it can be converted to closed centre or 'carry over' system.
- b Load sensing hydraulics. This kit must be used when the tractor requires a load sensing system.

Ensure that the correct kit is used.

Correct the relevant hoses to the tractor, referring to the tractor instruction manual for the correct tappings into the tractor hydraulic system.

4 REMOTE CONTROL LEVERS (if fitted)

The hydraulic control valves have the cable control already connected to the control valve and the lever console attached to the mainframe.

The cables can be routed through the rear cab window, and should be as free of bends as possible. DO NOT PINCH CABLES IN CLOSED CAB WINDOW. If the tractor cab has special apertures for cables, then the lever unit should be fed through them before they are attached to the tractor cab.

IMPORTANT

THE CABLES MUST HAVE A BEND OF NOT LESS THAN 150MM (6") RADIUS

- a Attach console mounting bracket to side of cab.

IMPORTANT

SEE SEPARATE CAB FITTING INSTRUCTION SHEET SUPPLIED WITH THE MACHINE. IT IS ESSENTIAL NOT TO DRILL MOUNTING HOLES THROUGH ANY STRUCTURAL MEMBER OF THE SAFETY CAB.

- b Mount console on to the mounting bracket securely with the bolts provided.
- c Finally, check lever for smooth operation in both directions. If any stiffness is felt or if lever does not return to centre, check cable run for sharp bends.

IMPORTANT

WHENEVER THE MACHINE IS REMOVED AND THE TRACTOR IS OPERATED WITH THE CONTROL VALVE CONSOLE IN PLACE, FIT RUBBER BEADING (CONTAINED IN THE CAB FITTING KIT) TO THE EDGE OF THE CONSOLE MOUNTING BRACKET TO PREVENT RISK OF INJURY.

5 CONTROL VALVE OPERATION - LEVERS

A control valve operation instruction plate is provided just behind the levers, clipped to the cables, to indicate the lever movement. If this plate is damaged in any way it must be replaced. A typical plate is reproduced below. Familiarize yourself with the operation of these levers before commencing work.

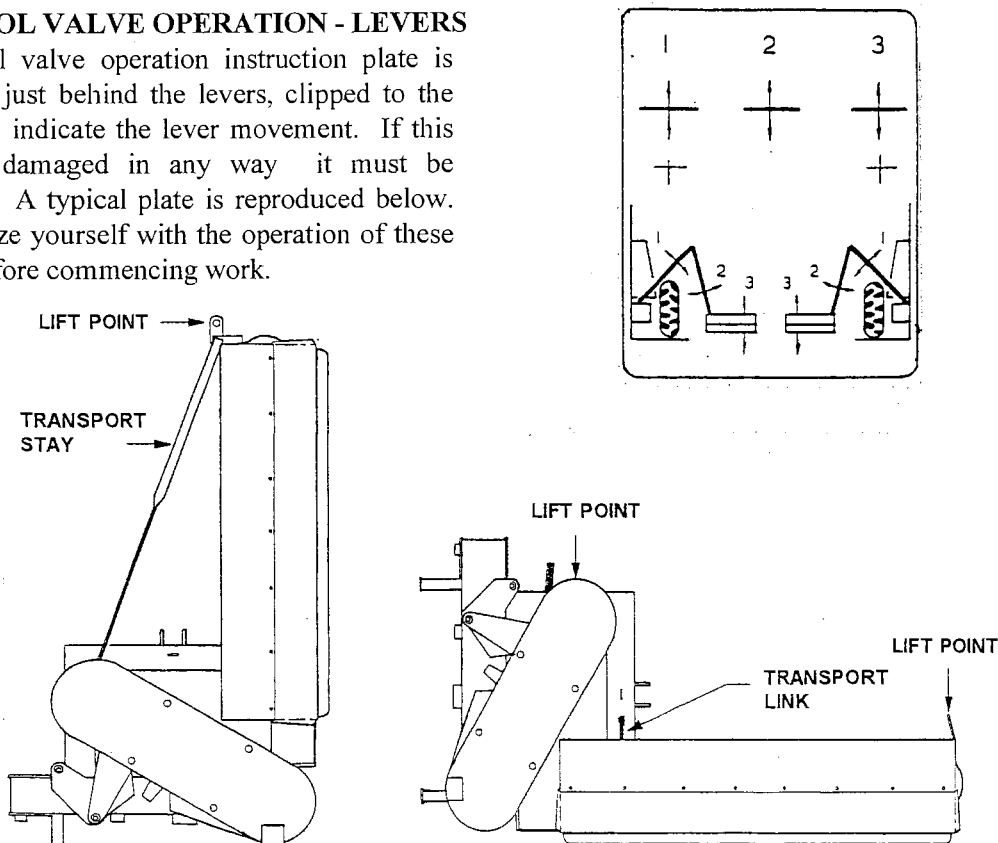
**6 TRANSIT STAY REMOVAL****IMPORTANT**

COWL RAM MUST BE BLED BEFORE THE STAY SUPPORTING THE COWL IS REMOVED. FAILURE TO BLEED RAM WILL RESULT IN THE COWL CRASHING TO THE GROUND.

- a Slacken the 1/4" BSP hose nut at the rod end of the cowl ram.
- b Start tractor engine and ensure that controls are switched to the auxiliary hydraulics.
- c Operate the cowl ram control valve lever until oil appears at the slackened joint.
- d Stop tractor engine.
- e Tighten hose joint on ram.
- f Stand clear of unsupported cutting unit and remove transport stay and any other transit straps.
- g Restart tractor engine.
- h Operate the cowl ram control and lower the cowl to the ground. Raise and lower cowl several times to ensure all the air is expelled

BLEEDING THE SLEW RAM

- i Operate slew ram controls and open and close several times to exclude any air.
- j Stop tractor engine.
- k Check all hose joints for leaks.
- l Top up tractor hydraulic oil reservoir (see Tractor Manual for recommended oils).

NOTE

DO NOT PRESSURIZE THE ARM RAM WITH THE TRANSIT STAY IN POSITION.

7 CONNECTING HOSES

It is important that hoses are fitted and aligned correctly. Hoses should never be twisted or kinked. On most hoses there is a line which runs the full length of the hose which acts as a useful guide. If there is no guide line along the hose follow the fitting instructions below.

- a Attach angled end of hose to its coupling but do not tighten. Either end can be attached if both ends of hose are straight, although most hoses on BOMFORD TURNER machines have one end with an angle bend.
- b Position the hose to its required route.
- c Connect other end loosely to its union.
- d Tighten angled end of hose in required position.
- e Tighten straight end. It may be found that as the nut is tightened the hose may twist slightly. If this happens follow instruction (f), if it does not twist follow from instruction (h).
- f Slacken off nut and turn hose in opposite direction to that of twist.
- g Retighten nut and bring hose back centrally.
- h Tighten hose clamps and clips where applicable.
- i Finally, operate the arms to all positions to ensure that the hoses are clear of any obstructions and also that the pipes are not pulling tight due to being clamped up incorrectly.
- j Always give plenty of clearance around sharp edges.

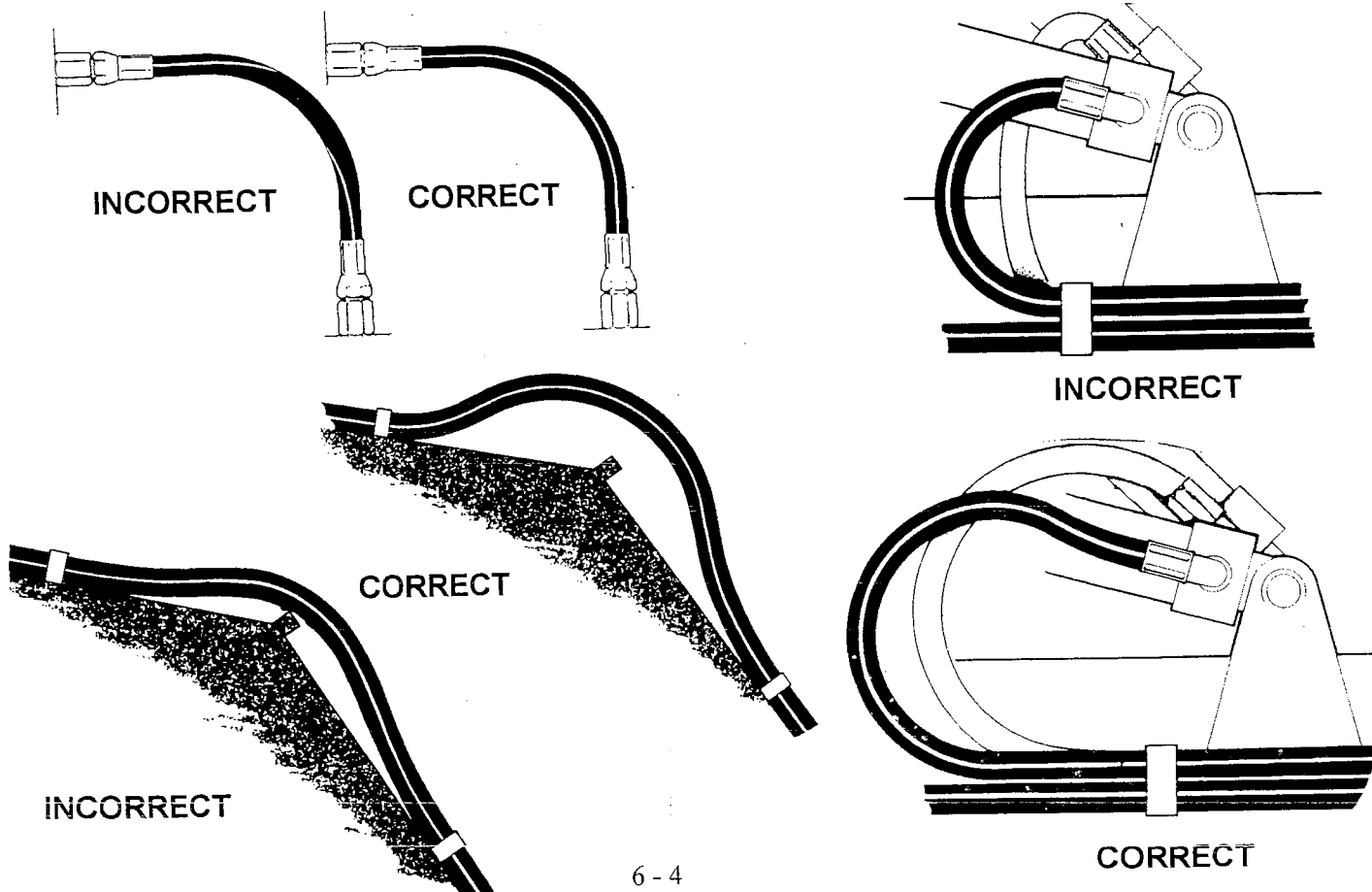

1 INITIAL RUN

- a Raise the rotor unit off the ground using the hydraulics.
- b Ensure nobody is standing near to the machine.
- c Run tractor engine at idle speed and engage PTO drive.
- d If rotor starts increase PTO speed gradually to 1000 rev/min.
- e If rotor fails to start stop tractor engine; check PTO drive and belt tension.
- f Allow the machine to run for approximately ten minutes.
- g Stop the machine immediately if excessive noise is heard or vibration is felt and refer to Maintenance section.

2 NORMAL RUN-UP

- a With a new machine never start cutting in arduous conditions. Allow at least one day's light work for running in.
- b Never attempt to start the machine while it is under load at any time. Always free rotor shaft from any obstructions.
- c Never increase or decrease PTO speed rapidly as this can lead to gearbox damage.

WARNING

STOP RUN UP IMMEDIATELY IF NOISE IS DETECTED FROM THE ROTORS
OR GEARBOX, AND REFER TO SAFETY PRECAUTIONS' SECTION

3 DRIVE BELT TENSIONING (See section on Maintenance)

Before operating the machine it is essential that the belts are checked for tension.

1. It is essential that in the interests of safety all guards and the roller must be kept in position on the machine whenever the machine is running. Bomford Turner Ltd disclaim all responsibility for any damage or injury arising as a result of guards or roller being removed, or of guards other than of Bomford Turner manufacture having been fitted, or of operation of the machine other than in accordance with these instructions.

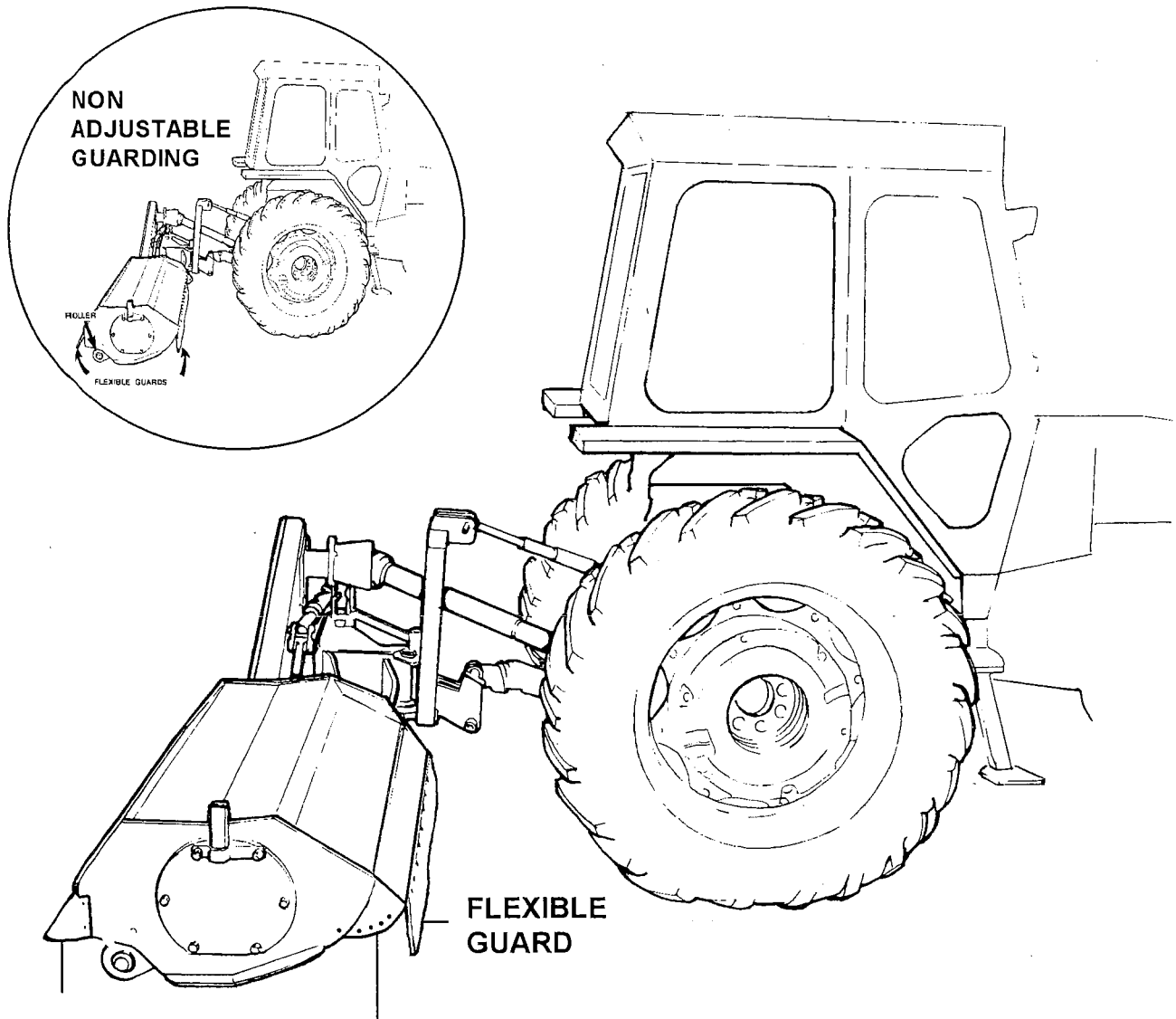

**FLEXIBLE
GUARD**

**ADJUSTABLE
GUARD**

IMPORTANT

INSPECTION OF GUARDS

Inspect guards twice daily or immediately damage is suspected.

Replace guards that have damage or wear which could impair their performance, as follows:

- a **STEEL GUARD:** distorted or with sharp outer edges.
- b **WIRE TRAP GUARD:** with bent, missing or blunt cutting edge.
- c **FLEXIBLE GUARD:** with missing portions, damaged, or worn sufficiently to permit stones to be ejected beneath it in normal conditions.

IF IN DOUBT CONSULT BOMFORD TURNER SERVICE.

1 OPERATOR

These notes are produced for guidance and are intended to help you obtain the best results with the minimum of trouble and downtime.

Read the following pages carefully and familiarize yourself with the contents.

Make a note of the serial numbers stamped on the top of the mainframe and the rotor itself. Always quote these numbers in any correspondence with your dealer.

2 INITIAL CHECKS

Check that the tractor is equipped to deliver 1000 rev/min at the power take-off shaft. IN NO CIRCUMSTANCES MUST THE PTO EXCEED 1050 REV/MIN.

3 NORMAL PRE-START CHECKS

- a Check that the rotor shaft is free from obstructions, especially pieces of wire.
- b Check that all flails are in good condition and securely attached to the shaft.
- c Check that all guards are in their correct places and in good condition. See Section 8.
- d Check that the roller is in place and correctly adjusted.
- e Examine the job to be cut. It is very important that the work site is inspected before cutting and all hidden obstructions removed or their position marked so that these may be avoided.
- f Check ditches for tree stumps, drain pipes, large stones, etc.

4 OPERATING HINTS

- a AVOID wire. STOP the tractor engine instantly if an unusual noise is heard from the machine. On no account raise or move the cutting unit until the rotor has stopped. NEVER IN ANY CIRCUMSTANCES run the rotor to clear itself.
- b AVOID stumps and pipes, etc. Stalling in heavy growth may cause damage to the rotor shaft.
- c DO NOT allow personnel near the machine while it is operating.
- d AVOID rushing into material when operating. Remember the unit has to chop material as well as cut it to the required height.
- e AVOID taking too much material by selecting the appropriate forward gear.
- f Run rotor at normal speed.
- g Advantage may be gained in exceptional conditions to take narrow cuts with part of the rotor shaft running idle.
- h When cutting it is always advisable to take a cut along the edges of ditches, etc. so that the ditch limits can be seen.

5 STALLING THE ROTOR

If the rotor becomes choked the tractor will stall or the belts will slip.

If this occurs follow the instructions below:

- a Stop forward motion, disengage PTO drive immediately and place PTO drive lever in neutral.
- b Ensure that the rotor has stopped and lift the rotor unit using the hydraulics.
- c Stop the tractor engine.
- d Remove any obstructions that may be present on the rotor. If working under the raised machine, ensure that it is safely supported.
- e NEVER IN ANY CIRCUMSTANCES run the rotor to clear itself.

6 BREAKOUT

A vertical link gravity breakout is fitted at the lift arm attachment point in the mainframe. This will reduce the risk of damage if an obstruction is encountered during work.

7 ROLLER HEIGHT

The roller is pre-set in its raised position before leaving the factory. The method of adjustment is detailed in the section on Maintenance.

8 TRANSPORT

Normally the machine will need to be at the driver's work site before commencing work. To keep the machine/tractor width to a minimum it will be necessary to place the machine in the transport position. This is described and illustrated below.

- a The tractor must be stationary.
- b Retract the cowl ram.
- c Retract the offset ram.
- d Do not transport with PTO drive engaged.
- e Fit link between mainframe and cowl.
- f To remove machine from the transport position the above sequence is reversed.

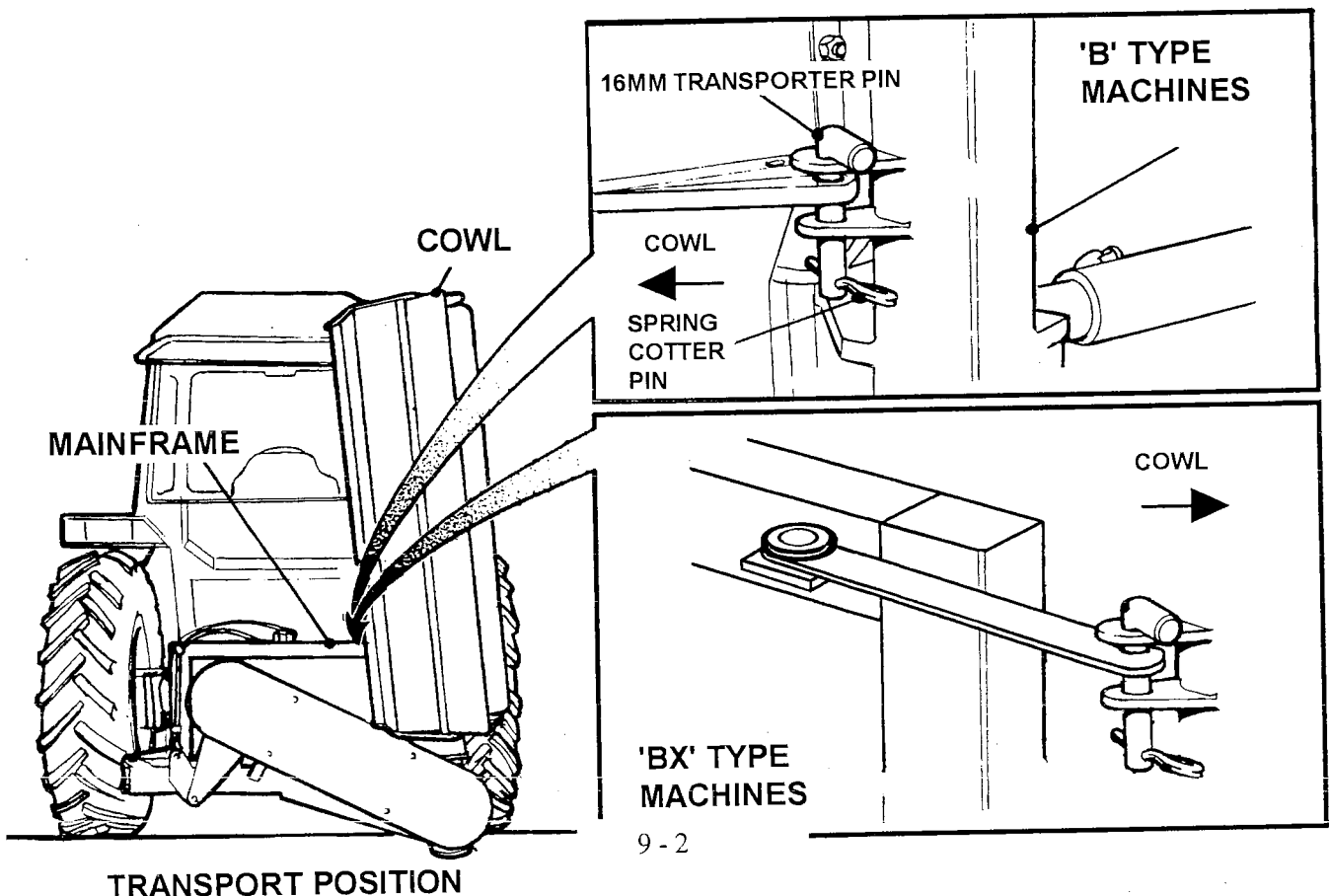

1 CONVERTING TO 540 REV/MIN PTO OUTPUT

- a Ensure that the tractor rev counter is checked and marked so that under no circumstances can 540 rev/min PTO be exceeded.
- b If necessary obtain a yoke to convert your PTO shaft to match tractor.
- c The drive pulleys are set up for 1000 rev/min PTO input and need to be reversed for 540 rev/min PTO output.

The method of reversing the pulleys is detailed below:

- a Remove drive cover.
- b Slacken drive belts by unscrewing the adjusting bolt and remove belts.
- c Remove 180 p.c.d. pulley from the PTO drive shaft.
- d Remove 250 p.c.d. pulley from the gearbox shaft.
- e Fit 250 p.c.d. pulley on to the PTO drive shaft.
- f Fit 180 p.c.d. pulley on to the gearbox shaft.
- g Fully tighten all grub screws and setscrews.
- h Refit the drive belts and tension to correct setting.

2 ROLLER ADJUSTMENT

- a Raise the rotor unit off the ground.
- b Stop tractor engine and disengage PTO drive.
- c Place a strong support under the side skids.
- d Slacken off the pivot bolts of the roller bracket.
- e Remove remaining bolts and nut from roller bracket.
- f Lower or raise the roller to the height required.
- g Replace bolts in required hole.
- h Fully tighten all nuts on both sides.
- i Remove support and lower the rotor unit to the ground.

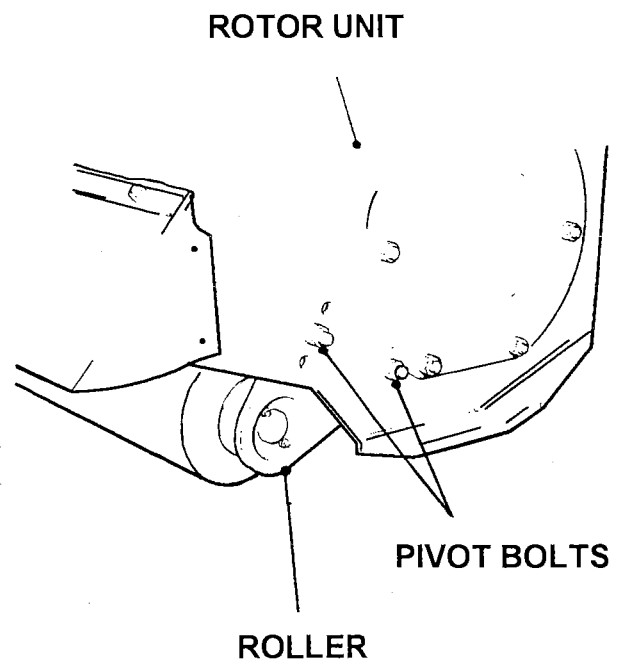

IMPORTANT

THE ROLLER MUST BE KEPT IN POSITION AT ALL TIMES AS IT IS AN ESSENTIAL PART OF THE ROTOR UNIT GUARDING

3 TENSIONING DRIVE BELTS

The rotor shaft/gearbox is driven from the PTO via the 'V' belts which are adjustable for tension. The following instruction describes the procedure for tightening the belts.

- a Lower the rotor unit to the ground using the hydraulics.
- b Stop tractor engine and disengage PTO drive.
- c Remove drive guard cover.
- d Slacken locknut sideplate screw and adjustment locknut.
- e Turn nut adjusting bolt in an anticlockwise direction until each belt can be deflected 16mm by applying a force of 6.1 to 9.2kg at right angles to the belt in the centre of the two pulleys.

IMPORTANT

DO NOT OVERTIGHTEN BELTS as this may cause premature failure of belts and gearbox/PTO bracket bearings.

- f Tighten locknut and recheck belt tension.
- g Refit drive guard cover.

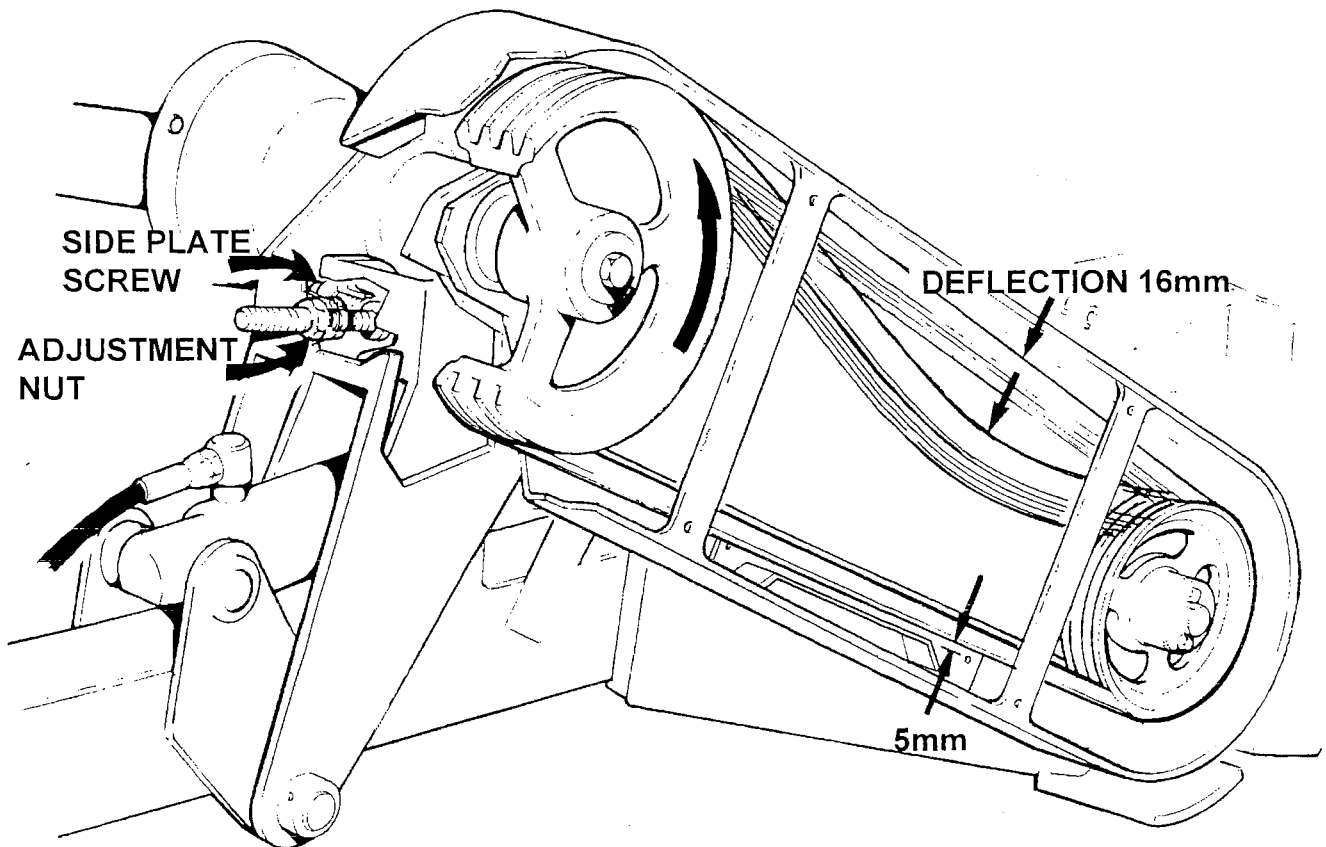

4 GEARBOX LUBRICATION

The gearbox is filled with 1.7 litres of EP90 oil before it leaves the factory and should not need topping up unless the gearbox is taken apart for any reason. However, it is advisable to check the level now and again through the level plug provided.

5 GREASING

Note: Greasing points are at the positions shown below. The frequency of greasing is shown on the adjacent lubrication table.

Make greasing easier by relieving the weight from the pivot pins. Rest the rotor on the ground, stop tractor engine and operate control levers in both directions.

LUBRICATION CHART

	DAILY	WEEKLY	MONTHLY
ROTOR SHAFT BEARINGS	●		
P.T.O. SHAFT BEARINGS	●		
P.T.O. SHAFT TUBES		●	
PIVOT PINS	●		
ROLLER BEARINGS	●		
OIL TANK			●
GEARBOX			●
GREASE ●	OIL ○	CHECK ○	

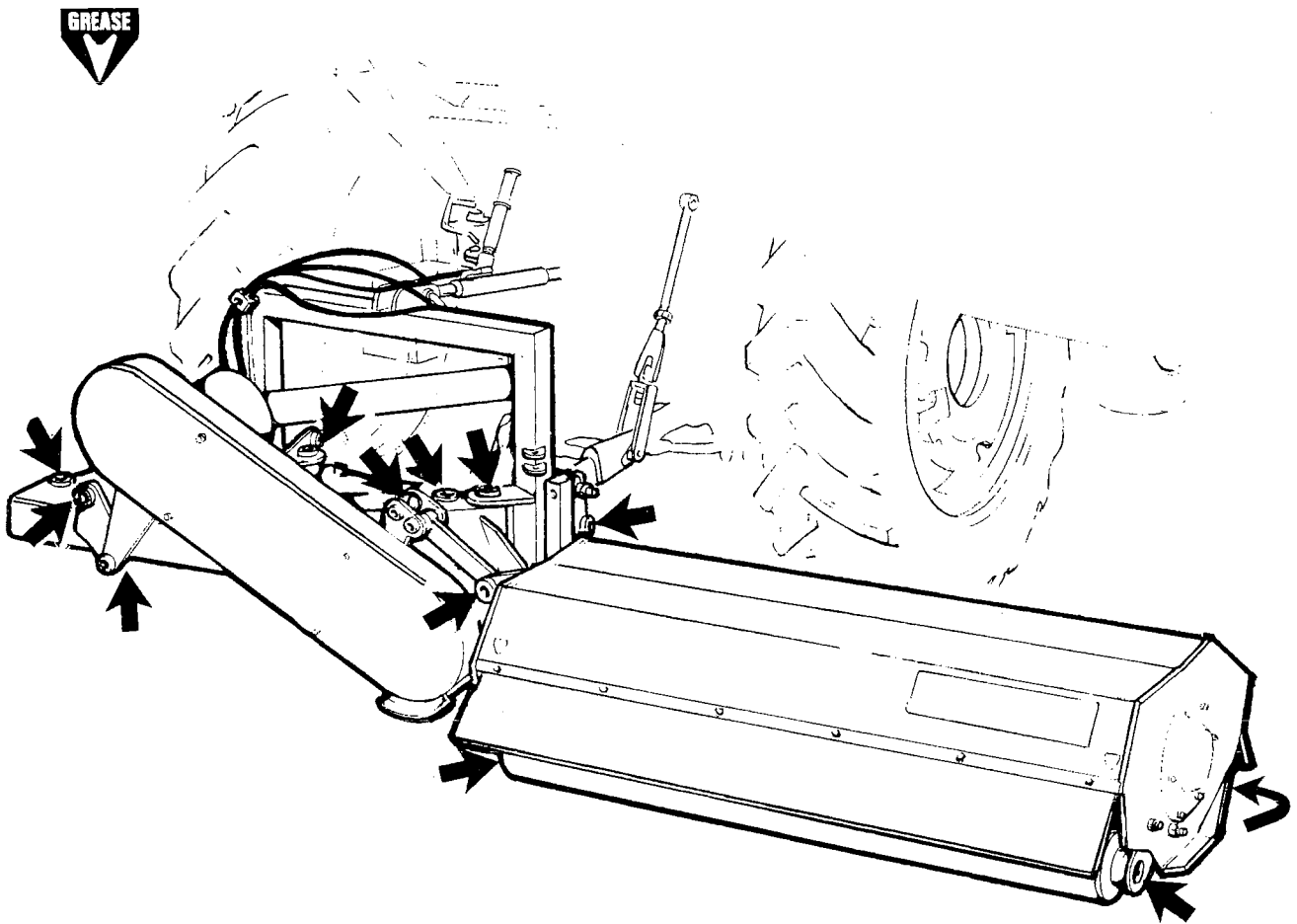

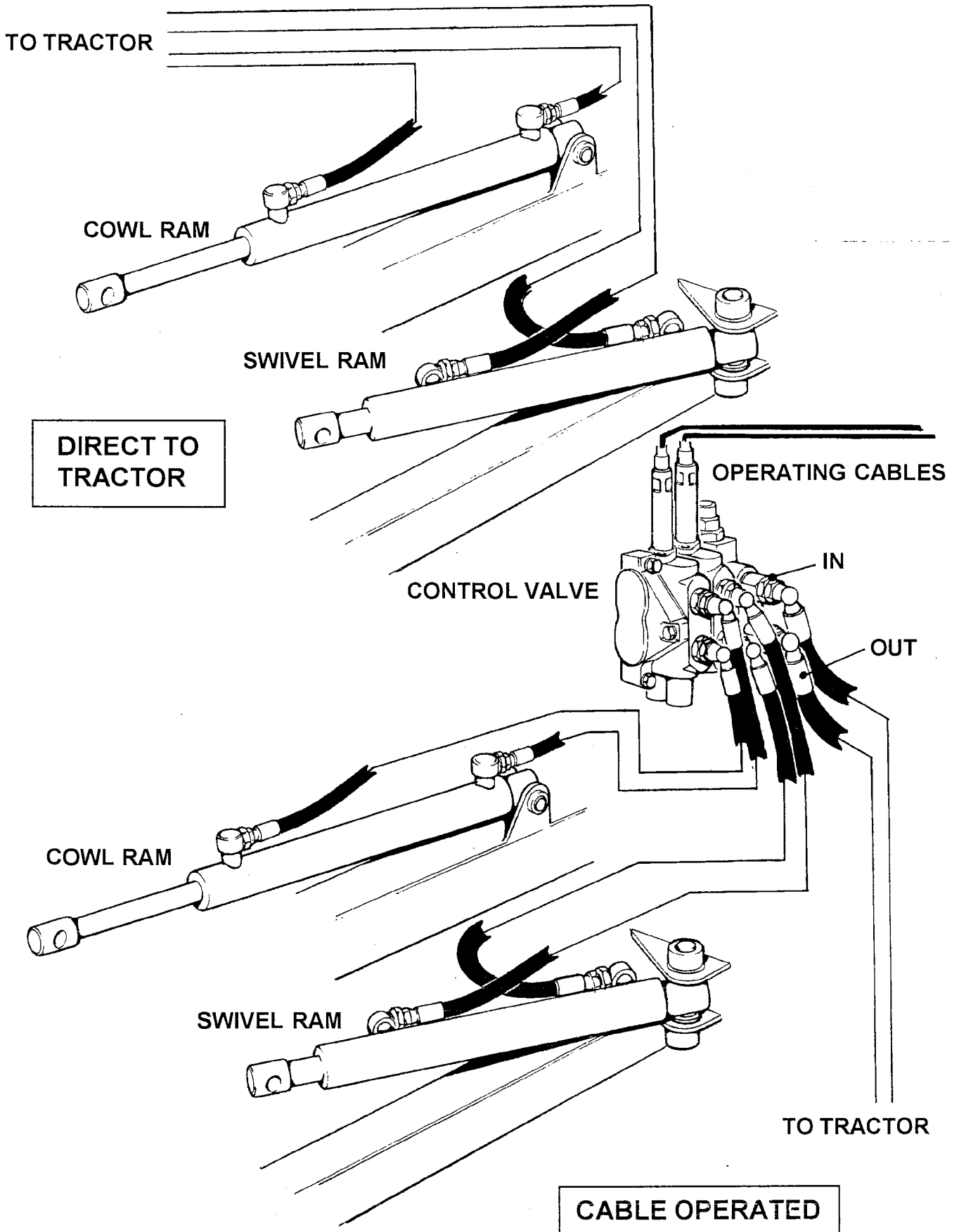

1 STORAGE

Before removing the machine from the tractor a thorough check should be made, as follows:

- a Thoroughly clean all moving parts, particularly the rotor unit.
- b Check all flails are in place and that they are in good condition.
- c Check all hoses for damage such as cracks, evidence of chafing and leaks.
- d Slacken off tension from drive belts.
- e Smear all unpainted metal parts with grease and lubricate all grease nipples.
- f Make a note of any item that needs replacing so that parts can be ordered.

2 PARKING AND REMOVAL

In the parked position the machine is supported by two stands on the mainframe and also by the rotor unit.

- a Place the rotor unit on the ground.
- b Disengage PTO drive
- c Lift the mainframe on the tractor lift arms, lower stands and pin in position.
- d Lower mainframe on to its stands.
- e Stop tractor engine and operate control valve levers in both directions to release pressure.
- f If fitted, remove control lever console from inside tractor and feed through rear of cab. Without bending cables too tightly, tie console on to mainframe and protect from weather.
- g Fit rubber beading supplied with cab fitting kit to the edge of console mounting.
- h Release tractor end of PTO shaft, pull back along splines and release from shaft.
- i Slacken lift arms and check chains.
- j Slacken adjustable top link and remove.
- k Remove lynch pin and rings securing lift arms to mounting pins.
- l Remove lift arms from mounting pins.
- m Start tractor and drive carefully forward, releasing machine and PTO shaft from tractor.
- n Replace lower link pins, ensuring breakout link is pinned to the mainframe.
- o Place cap over tractor PTO.
- p Remove the machine PTO and store in a safe place

PM1756

B324, BX364

**JIC
VERGE MOWERS**

PARTS MANUAL

ISSUE 9

IMPORTANT

NOTE HERE THE SERIAL NUMBER OF YOUR MACHINE AND ALWAYS QUOTE IT IN ANY COMMUNICATION WITH US OR YOUR DEALER. THIS IS PARTICULARLY IMPORTANT WHEN ORDERING SPARES. REMEMBER TO INCLUDE ALL NUMBERS AND LETTERS.

MACHINE SERIAL NUMBERS _____

THE INFORMATION GIVEN THROUGHOUT THIS MANUAL IS CORRECT AT THE TIME OF PUBLICATION. HOWEVER, IN THE COURSE OF CONSTANT DEVELOPMENT OF BOMFORD TURNER MACHINES, CHANGES IN SPECIFICATION ARE INEVITABLE. SHOULD YOU FIND THE INFORMATION GIVEN IN THIS BOOK TO BE AT VARIANCE WITH THE MACHINE IN YOUR POSSESSION, YOU ARE ADVISED TO CONTACT THE BOMFORD TURNER SERVICE DEPARTMENT WHERE UP-TO-DATE INFORMATION WILL BE PROVIDED.

THE MANUAL CAN CONTAIN STANDARD AND OPTIONAL FEATURES AND IS NOT TO BE USED AS A MACHINE SPECIFICATION.

THE MACHINE HAS BEEN TESTED AND IS CONSIDERED SAFE IF CAREFULLY USED. ENSURE YOUR OPERATOR IS PROPERLY TRAINED IN ITS USE AND MAINTENANCE.

IMPORTANT

NOTEZ ICI LES NUMEROS DE SERIE DE VOTRE MACHINE ET MENTIONNEZ LES DANS TOUTE COMMUNICATION AVEC NOS SERVICES OU VOTRE REVENDEUR. CE CI EST IMPORTANT POUR LA COMMANDE DE PIECES DETACHEES. PENSEZ A NOTER TOUS LES NUMEROS ET TOUTES LES LETTERS.

NUMEROS DE SERIE DE LA MACHINE _____

LES INFORMATIONS DONNEES DANS CE MANUEL SONT CORRECTES CEPENDANT, DU FAIT DE DEVELOPPEMENT CONSTANT DES MACHINES BOMFORD TURNER.

CHANGEMENTS DANS LES CARACTERISTIQUES SONT INEVITABLES.

SI VOUS TROUVEZ QUE LES INFORMATIONS DONNEES NE CORRESPONDENT PAS A VOTRE MACHINE VEUILLEZ CONTACTER LE SERVICE DES REPARATIONS OU DES INFORMATIONS PLUS RECENTES VOUS SERONT DONNEES. CE MANUEL PEUT MONTRER DES CARACTERISTIQUES OPTIONNELLES ET NE PEUT PAS ETRE CONSIDERE COMME SPECIFICATION DE LA MACHINE.

CETTE MACHINE A ETE TESTEE, ET ELLE EST CONSIDEREE COMME FIABLE A CONDITION D'UNE BONNE UTILISATION. ASSUREZ-VOUS QUE VOTRE OPERATEUR EST QUALIFIE EN CE QUI CONCERNE L'UTILISATION DE LA MACHINE AINSI QUE SON ENTRETIEN.

WICHTIG

TRAGEN SIE HIER DIE SERIENNUMMERN IHRER MASCHINE EIN UND GEBEN SIE DIESE IMMER AN, WENN SIE SICH AN UNS ODER IHREN HÄNDLER WENDEN. DAS IST BESONDERS BEI ERSATZTEILBESTELLUNGEN WICHTIG. VERGESSEN SIE NICHT, ALLE ZAHLEN UND BUCHSTABEN ZU NOTIEREN.

SERIENNUMMERN DER MASCHINE _____

DIE ANGABEN IN DIESEM HANDBUCH SIND BEI VERÖFFENTLICHUNG KORREKT. AUFGRUND DER KONSTANTEN WEITERENTWICKLUNG VON BOMFORD TURNER MASCHINEN SIND JEDOCH ÄNDERUNGEN IN DER SPEZIFIKATION UNVERMEIDLICH. WENN DIE INFORMATION IN DIESEM HANDBUCH NICHT MIT IHRER MASCHINE ÜBEREINSTIMMEN, NEHMEN SIE BITTE KONTAKT MIT DER BOMFORD TURNER KUNDENDIENSTABTEILUNG AUF, DIE IHNEN GERNE DIE AKTUELLEN INFORMATION ZUKOMMEN LÄSST.

DAS HANDBUCH KANN SOWOHL BESCHREIBUNGEN FÜR DIE STANDARD AUSFÜHRUNG ALS AUCH FÜR ZUBEHÖR ENTHALTEN UND IST NICHT ALS MASCHINENSPEZIFIKATION ZU VERWENDET.

DIE MASCHINE IST GETESTET UND BEI SACHGEMÄSSEM BETRIEB ALS SICHER BEFUNDEN WORDEN. SORGEN SIE DAFÜR, DASS IHR BEDIENPERSONAL IN ANWENDUNG UND WARTUNG RICHTIG GESCHULT WIRD.

B324 AND BX364 SIDESHIFT MACHINES

PAGE AND ILLUSTRATION NUMBERS ARE USED ONLY FOR REFERENCE PURPOSES AND SHOULD NOT BE USED FOR ORDERING SPARE PARTS. PLEASE ENSURE THE CORRECT PART NUMBER AND DESCRIPTION IS GIVEN WHEN ORDERING SPARE PARTS.

For B324 JIC machines with serial numbers commencing from ..1276H....

For BX364 JIC machines with serial numbers commencing from ..2162H....

B324 JIC		BX364 JIC	
Page No.	Title	Page No.	Title
2 - 1 TO 2 - 2	MAINFRAME LINKS	9 - 1 TO 9 - 2	MAINFRAME LINKS
3 - 1 TO 3 - 2	ARM ASSEMBLY	10-1 TO 10- 2	ARM ASSEMBLY
4 - 1 TO 4 - 3	GEARBOX PTO SHAFT PULLEYS & BELTS	11-1 TO 11- 2	GEARBOX PTO SHAFT PULLEYS & BELTS
5 - 1 TO 5 - 2	RAMS & HOSES	12-1 TO 12- 2	RAMS & HOSES
6 - 1 TO 6 - 2	COWL ASSEMBLY	13-1 TO 13- 2	COWL ASSEMBLY
7 - 1 TO 7 - 2	ROTOR SHAFTS BEARINGS	14-1 TO 14- 2	ROTOR SHAFTS BEARINGS
8 - 1	DECALS	15-1 TO 15 -6	DECALS

OPTIONAL EXTRA

Page No.	Title
16-1 TO 16-2	ACCUMULATOR ASSY
17-1 TO 17-2	JOYSTICK VALVE KIT

IMPORTANT

THIS MACHINE IS FOR VEGETATION CONTROL AND
MUST NOT BE USED FOR ANY OTHER PURPOSE

IT IS POTENTIALLY HAZARDOUS TO FIT OR USE
ANY PARTS OTHER THAN GENUINE BOMFORD TURNER PARTS

THE COMPANY DISCLAIMS ALL LIABILITY FOR THE
CONSEQUENCES OF SUCH USE, WHICH IN ADDITION
VOIDS THE MACHINE WARRANTY

B324

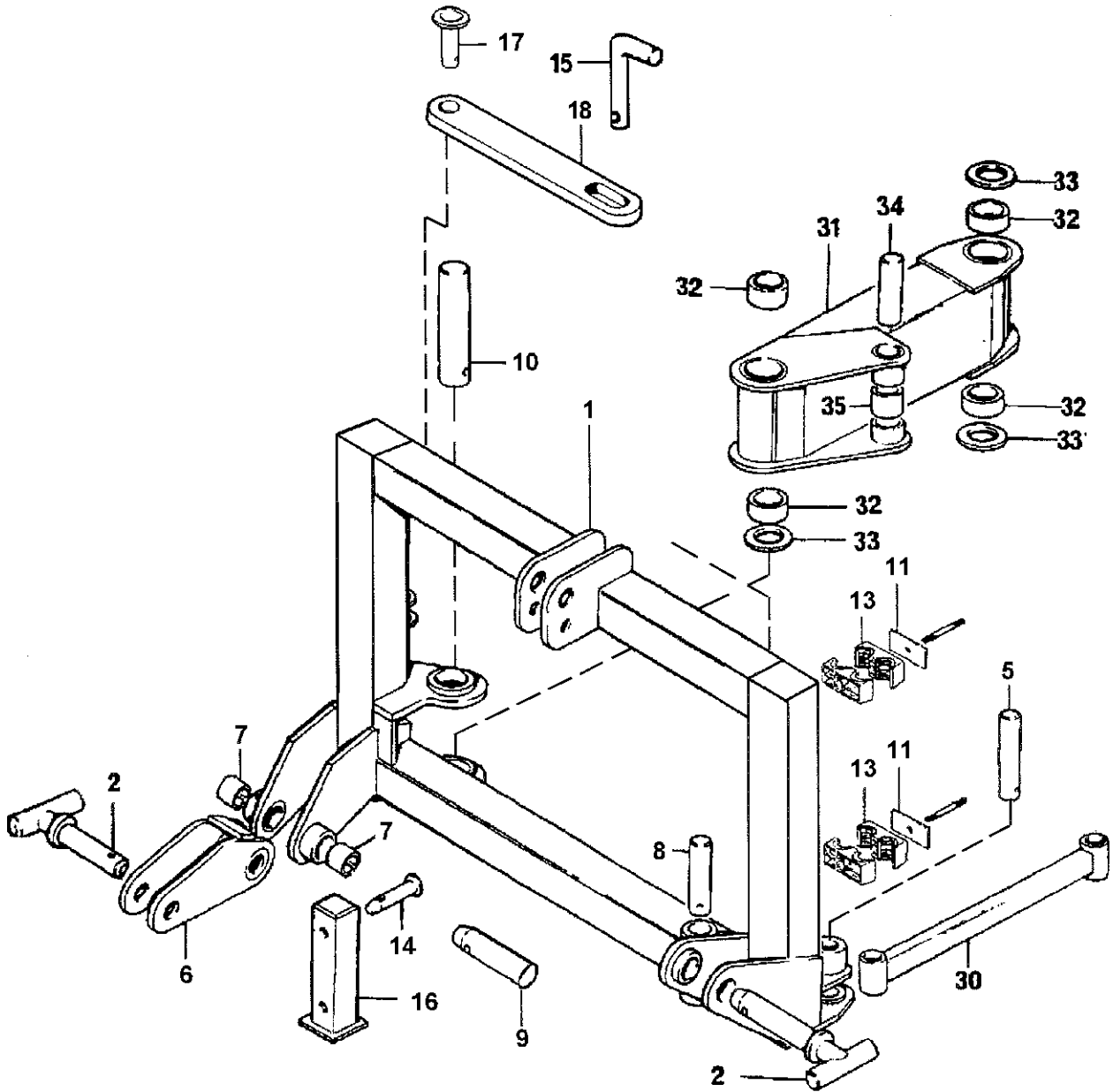

REF	PART NO	DESCRIPTION	QTY
74.781.02/03 MAINFRAME ASSY REAR LH/RH			
*01	09.248.07	MAINFRAME REAR LH	1
01	09.248.06	MAINFRAME REAR RH	1
01	05.227.01	HAMMER DRIVE SCREW NO.6 X 3/8"	2
01	05.774.06	SERIAL NO.PLATE BOMFORD TURNER	1
02	00.372.01	LINCH PIN	2
02	05.964.01	SPRING COTTER 3.6MM DIA	2
02	06.318.01	PIN-1.1/8" DIA X 103	2
*05	03.654.19	PIN 30 DIA X 153	1
05	05.201.07	TENSION PIN 8MM X 45MM PLATED	1
06	09.241.01	LINK - BREAKOUT	1
07	02.771.06	TENSION BUSH 35 X 30 X 30	2
08	03.653.54	PIN 25 DIA X 129	1
08	05.291.05	BOLT, M8 X 50	1
08	05.287.01	NUT, SELF LOCKING, M8	1
*09	03.654.19	PIN 30 DIA X 153	1
09	05.201.07	TENSION PIN 8MM X 45MM PLATED	1
*10	03.656.62	PIN 40 DIA X 256MM	1
10	05.282.02	SPRING WASHER 10MM PLATED	1
10	05.286.02	NUT M10 PLATED	1
10	05.292.11	BOLT M10 X 80MM PLATED	1
*11	06.418.02	CLAMP PLATE 30 X 6 PLATED	8
11	04.282.30	STUD M8 X 85 PLATED	2
11	05.281.01	FLAT WASHER 8MM PLATED	2
11	05.282.01	SPRING WASHER 8MM PLATED	2
11	05.286.01	NUT M8 PLATED	2
13	06.430.02	CLAMP HOSE 14 X 14	1
*14	03.652.01	PIN 20 DIA X 90	1
14	00.372.01	LINCH PIN	1
*15	03.651.18	PIN 16 DIA X 68MM	1
15	05.953.01	GREASE NIPPLE M6	4
16	09.240.01	STAND	1
*17	03.652.23	PIN 20 DIA X 27	1
17	05.284.14	SPLIT COTTER 5MM X 40MM	1
18	42130.01	STRAP - TRANSPORT	1
72.482.01 SWING LINKS			
30	09.237.01	LINK - SWING	1
31	09.234.01	LINK - SWING RAM	1
32	08.297.02	BUSH - PLASTIC 47 X 40 X 40	4
33	09.232.01	THRUST WASHER	3
*34	03.653.56	PIN 25 DIA X 178MM	1
34	05.201.07	TENSION PIN 8MM X 45MM PLATED	1
34	05.953.01	GREASE NIPPLE M6	1
35	09.235.01	SPACER - 40 X 25.5 - 36	1

*MAIN PART IN GROUP, RELATED PARTS HAVE SAME REFERENCE NUMBER

B324

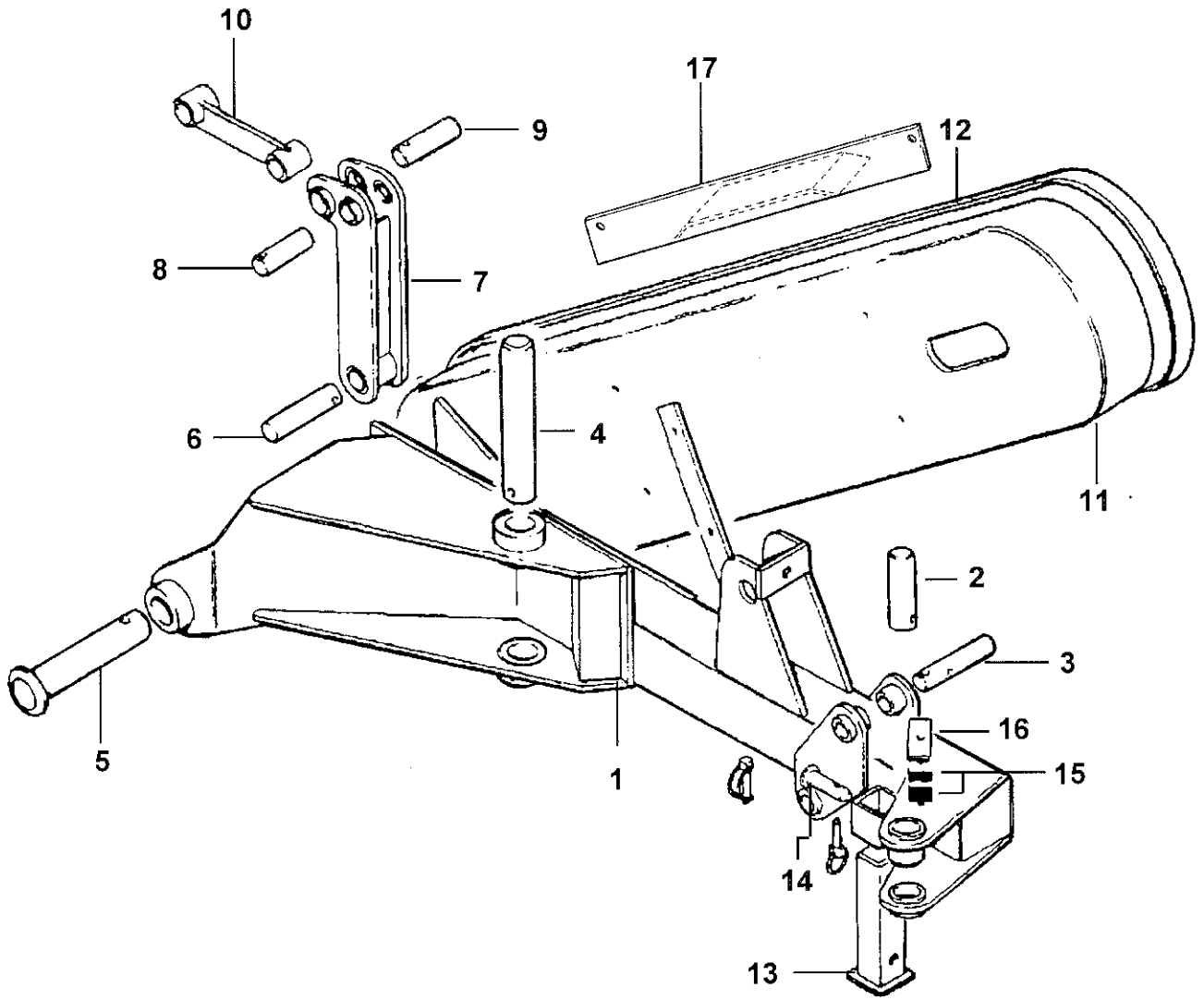

REF	PART NO	DESCRIPTION	QTY
		72.485.01 ARM ASSEMBLY LH/RH	
*01	09.300.02	ARM LH (RH-FM)	1
01	09.300.01	ARM RH	1
01	05.201.11	TENSION PIN 5MM X 45MM PLATED	2
*02	03.654.73	PIN 30 DIA X 140MM	1
02	05.953.01	GREASE NIPPLE M6	1
*03	03.653.25	PIN 25 DIA X 135	1
03	05.201.07	TENSION PIN 8MM X 45MM PLATED	1
03	05.282.01	SPRING WASHER 8MM PLATED	1
03	05.286.01	NUT M8 PLATED	1
03	05.291.06	BOLT M8 X 55MM PLATED	1
03	05.953.01	GREASE NIPPLE M6	1
*04	03.656.63	PIN 40 DIA X 283MM	1
04	05.282.02	SPRING WASHER 10MM PLATED	1
04	05.286.02	NUT M10 PLATED	1
04	05.292.11	BOLT M10 X 80MM PLATED	1
04	05.953.03	GREASE NIPPLE M10	1
*05	03.656.61	PIN 40 DIA X 250MM	1
05	05.282.02	SPRING WASHER 10MM PLATED	1
05	05.286.02	NUT M10 PLATED	1
05	05.292.11	BOLT M10 X 80MM PLATED	1
05	05.953.01	GREASE NIPPLE M6	1
*06	03.654.08	PIN 30 DIA X 140MM	1
06	05.201.07	TENSION PIN 8MM X 45MM PLATED	1
*07	09.233.01	LINK - COWL RAM	1
07	05.953.01	GREASE NIPPLE M6	1
*08	03.653.55	PIN 25 DIA X 98MM	1
08	05.201.07	TENSION PIN 8MM X 45MM PLATED	1
*09	03.654.53	PIN 30 DIA X 92MM	1
09	05.201.07	TENSION PIN 8MM X 45MM PLATED	1
*10	09.231.01	LINK - COWL	1
10	05.953.01	GREASE NIPPLE M6	2
*11	41764.01	GUARD - REAR LH	1
11	41764.02	GUARD - REAR RH	1
11	05.264.12	SETSCREW M10 X 25MM PLATED	2
11	05.264.13	SETSCREW M10 X 30MM PLATED	2
11	05.282.02	SPRING WASHER 10MM PLATED	4
*12	41775.01	GUARD - COVER	1
12	05.264.11	SETSCREW M10 X 20MM PLATED	4
12	05.282.02	SPRING WASHER 10MM PLATED	4
13	09.240.01	STAND	1
*14	03.652.01	PIN 20 DIA X 90	1
14	00.372.01	LINCH PIN	1
*15	06.430.02	CLAMP HOSE 14 X 14	2
15	04.282.32	STUD M8 X 52	1
15	05.281.01	FLAT WASHER 8MM PLATED	1
15	05.282.01	SPRING WASHER 8MM PLATED	1
15	05.286.01	NUT M8 PLATED	1
16	06.418.02	CLAMP PLATE 30 X 6 PLATED	1
17	43008.01	BRACKET-BELT SUPPORT	1

*MAIN PART IN GROUP, RELATED PARTS HAVE SAME REFERENCE NUMBER

B324

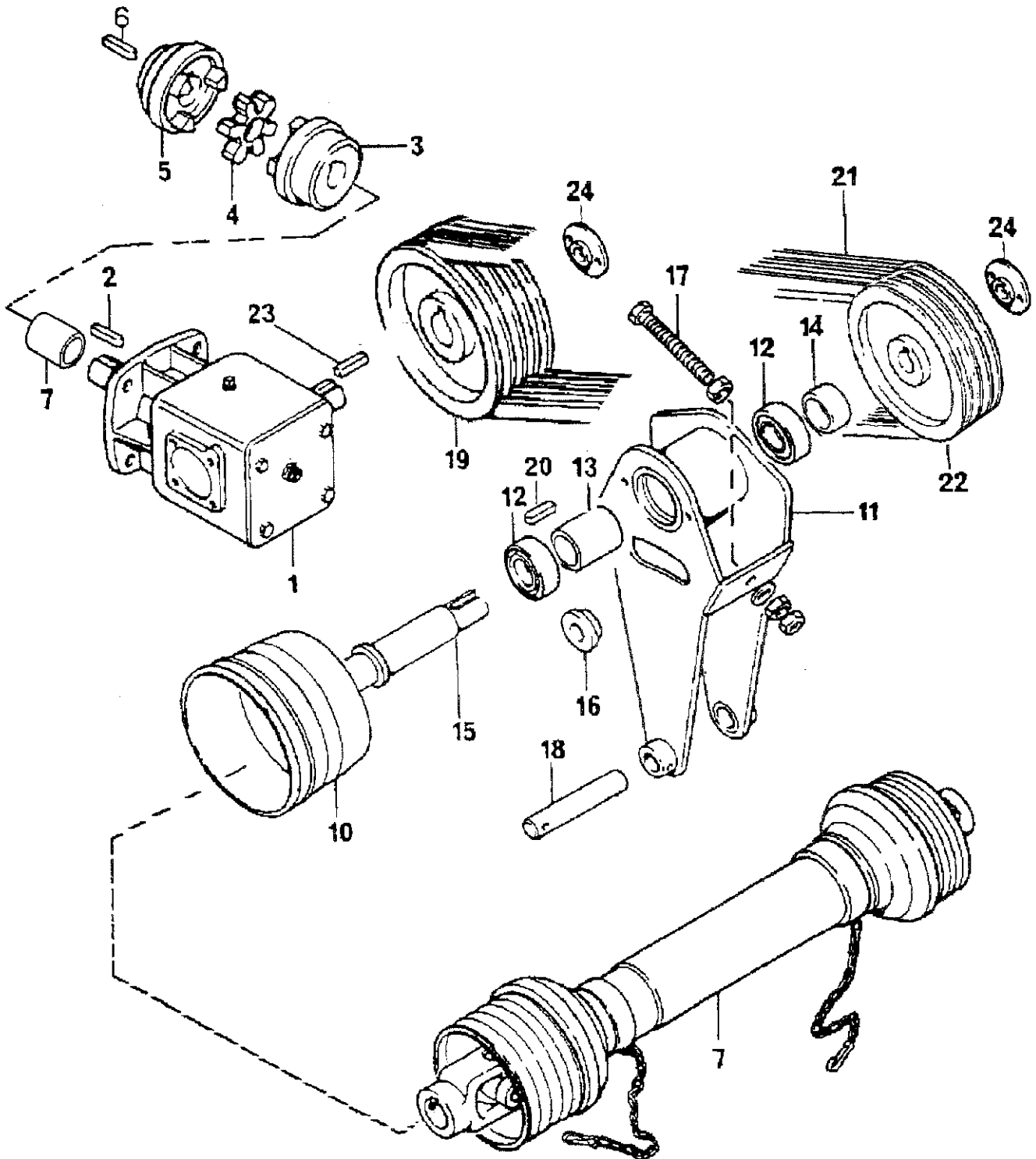

REF	PART NO	DESCRIPTION	QTY
72.552.01, 72.483.01 DRIVE BRACKET,PULLEYS & BELTS LH/RH			
*10	09.236.01	GUARD - PLASTIC PTO	1
10	05.264.11	SETSCREW M10 X 20MM PLATED	2
10	05.281.02	FLT WASHER 10MM PLATED FORM C	2
10	05.282.02	SPRING WASHER 10MM PLATED	2
11	41768.03	BRACKET - DRIVE RH FRONT	1
11	41768.01	BRACKET - DRIVE LH FRONT	1
12	03.007.06	BEARING - BALL 40MM BORE	2
13	09.259.01	SPACER 50 O/D X 40.2 I/D	1
14	09.264.01	SPACER 50 O/D X 40.2 I/D - 26	1
*15	41730.01	SHAFT - PULLEY/PTO	1
15	05.264.02	SETSCREW M8 X 25MM PLATED	2
15	05.264.24	SETSCREW M12 X 35MM PLATED	1
15	05.282.01	SPRING WASHER 8MM PLATED	2
15	05.282.03	SPRING WASHER 12MM PLATED	1
15	09.297.01	WASHER 75 O/D X 13 I/D X 6	1
15	41731.01	SPACER 50 X 40.2 - 10	1
*16	09.263.01	COLLAR - CLAMP	1
16	05.264.34	SETSCREW M16 X 35MM PLATED	1
16	05.282.04	SPRING WASHER 16MM PLATED	1
*17	41769.01	BOLT - ADJUSTMENT	1
17	05.281.04	FLAT WASHER 16MM PLATED	4
17	05.286.04	NUT M16 PLATED	3
*18	03.653.57	PIN 25 DIA X 170MM	1
18	05.201.07	TENSION PIN 8MM X 45MM PLATED	1
*19	41.245.01	PULLEY - 250 PCD X 4 SPB	1
19	05.388.01	SOCKET GRUBSCREW M8 X 25MM CONE PT	1
20	05.960.03	KEY-SEP 10MM X 8MM X 50MM	1
21	05.299.51	BELT XPB 2500 QUAD POWER GATES	4
*22	41.244.01	PULLEY - 180 X 4 SPB	1
22	05.388.01	SCKT GRUBSCREW M8 X 25MM CONE PT	1
23	05.960.22	KEY-REP 10 X 8 X 58	1
*24	09.297.01	WASHER 75 O/D X 13 I/D X 6	1
24	05.264.02	SETSCREW M8 X 25MM PLATED	2
24	05.264.23	SETSCREW M12 X 30MM PLATED	1
24	05.282.01	SPRING WASHER 8MM PLATED	2
24	05.282.03	SPRING WASHER 12MM PLATED	1

*MAIN PART IN GROUP, RELATED PARTS HAVE SAME REFERENCE NUMBER

B324

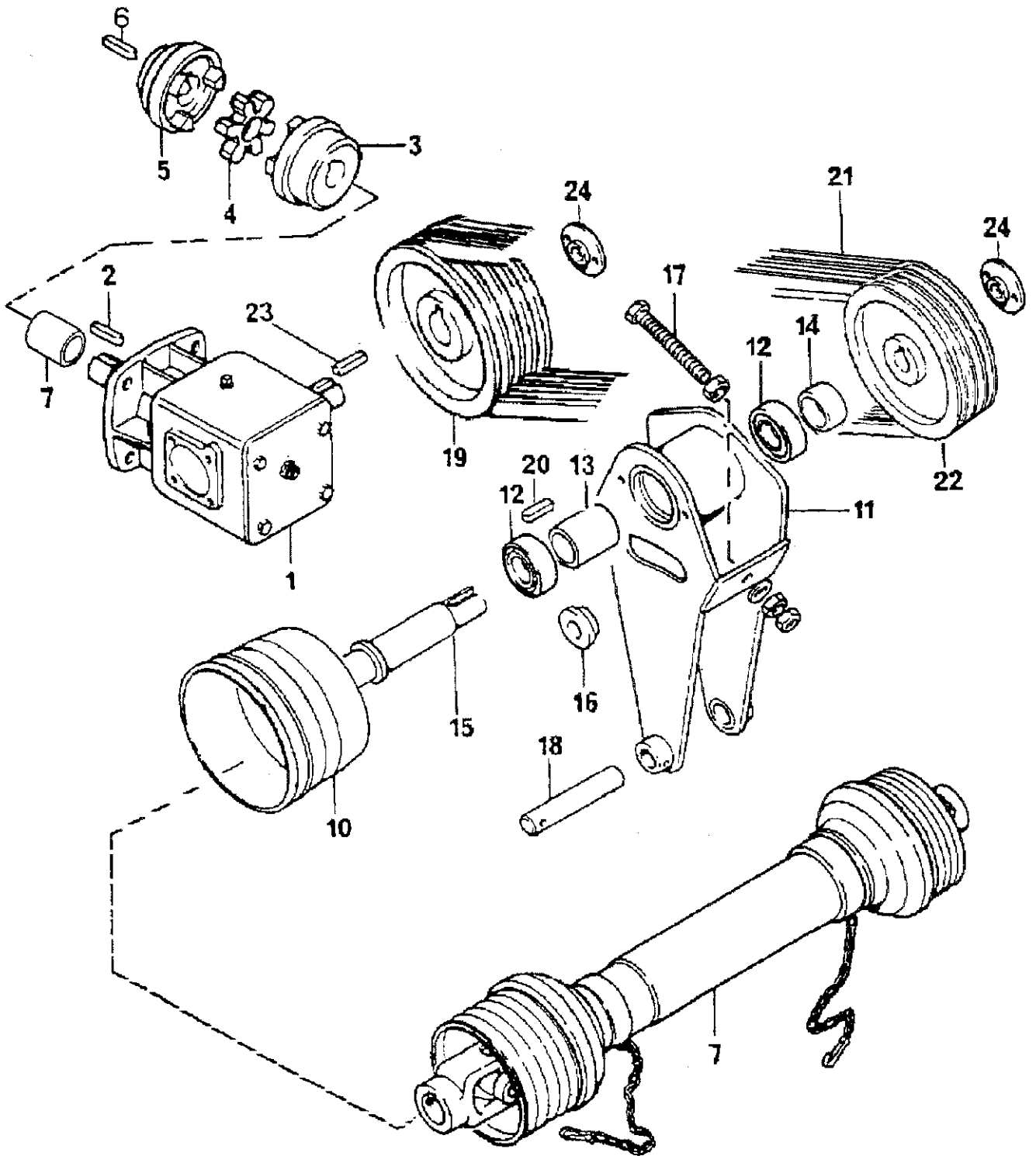

REF	PART NO	DESCRIPTION	QTY
72.484.01, 72.555.01 GEARBOX ASSEMBLY LH/RH			
01	09.250.04	GEARBOX ASSEMBLY COMER RH	1
01	02.824.01	WASHER 50 O/DX13 I/DX6MM	1
01	05.264.24	SETSCREW M12 X 35MM PLATED	1
01	05.282.03	SPRING WASHER 12MM PLATED	1
02	05.960.22	KEY-REP 10 X 8 X 58	1
03	05.388.01	SOCKET GRUBSCREW M8 X 25MM CONE PT	4
03	07.078.05	HUB - COUPLING (KEYED)	1
04	07.078.04	DRIVE - COUPLING	1
05	07.078.03	HUB - COUPLING (KEYED)	1
06	05.960.29	KEY-S/REP 12MM X 8MM X 37MM	1
07	42613.01	SPACER 50 X 35.5 - 33MM	1
72.478.01 PTO SHAFT ASSEMBLY			
*08	41624.06	PTO SHAFT ASSY 810MM C/C	1
08	41624.31	CROSS JOURNAL SET	-
08	41624.34	COMPLETE SHIELD	-

*MAIN PART IN GROUP, RELATED PARTS HAVE SAME REFERENCE NUMBER

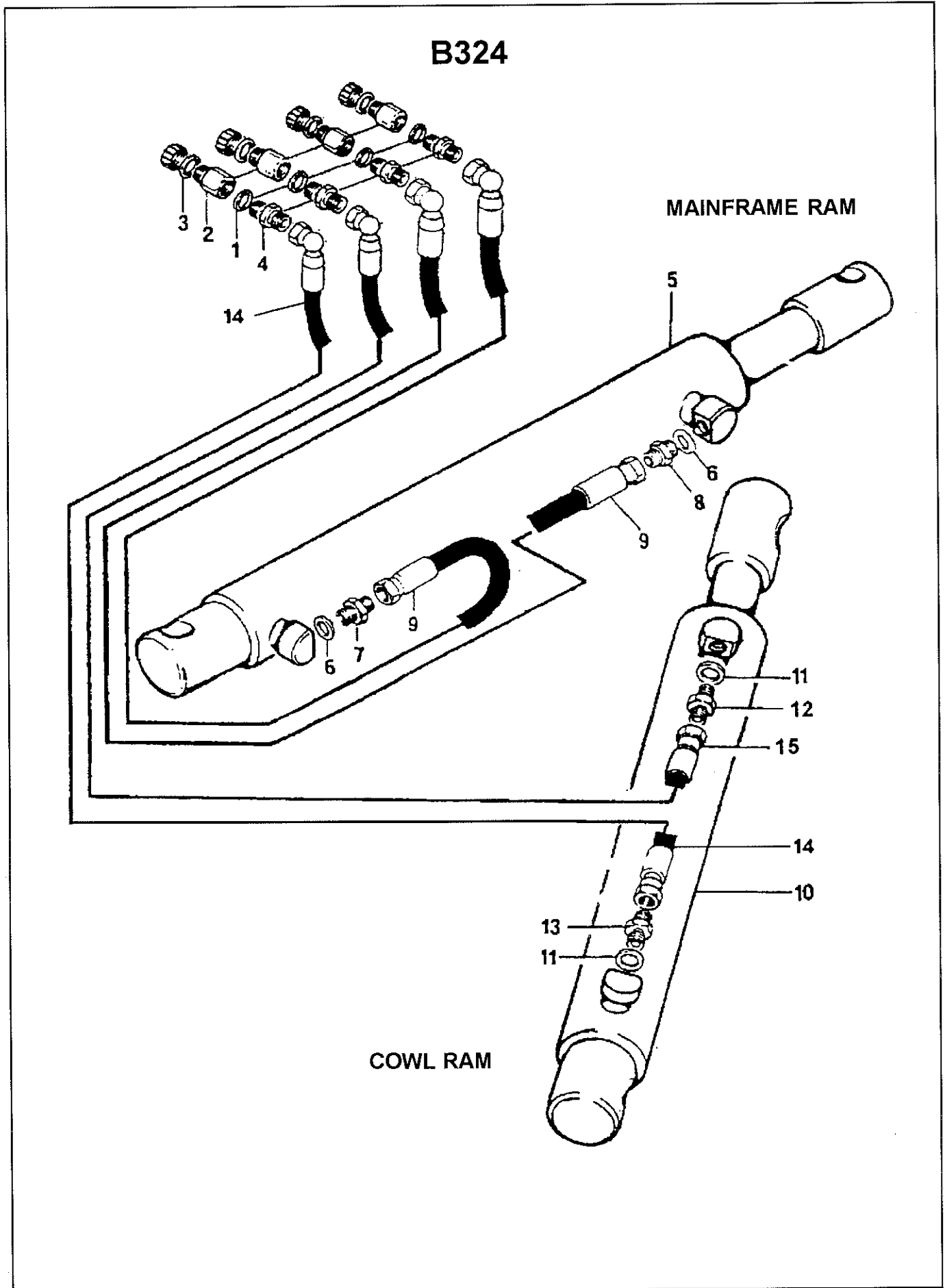

REF	PART NO	DESCRIPTION	QTY
72.477.02 RAMS/HOSES JIC			
01	05.290.05	BONDED SEAL 1/2"BSP	4
*02	05.225.01	ADAPTOR-RDCG.1/2"BSP X 3/8"BSP	4
02	05.300.03	PLUG-PLASTIC 1/2"BSP FEMALE	4
03	05.290.04	BONDED SEAL 3/8"BSP	4
04	08.955.06	ADAPTOR 3/8"BSP X 9/16"-18 JIC	4
*05	41.042.03	RAM ASSY - 50 BORE/35 ROD X	1
05	41.042.01	SEAL KIT - 41.042.XX RAMS.	-
06	05.290.04	BONDED SEAL 3/8"BSP	2
07	08.955.06	ADAPTOR 3/8"BSP X 9/16"-18 JIC	1
08	46518.27	RESTRICTOR 3/8"X9/16"JIC(1.70)	1
09	08.957.32	HOSE 1/4"BORE X 2400 JIC 90 X ST	1
*10	09.982.21	RAM ASSY-D/A 60 BORE X 430 STK	1
10	09.982.01	SEAL KIT FOR 09.982.XX RAMS	-
11	05.290.04	BONDED SEAL 3/8"BSP	2
12	08.955.06	ADAPTOR 3/8"BSP X 9/16"-18 JIC	1
13	46518.32	RESTRICTOR 3/8"X 9/16"JIC(1.00)	1
14	08.957.37	HOSE 1/4"BORE X 2900MM JIC90 X ST	1
15	08.957.42	HOSE 1/4"BORE X 3400MM JIC 90 X ST	1

*MAIN PART IN GROUP, RELATED PARTS HAVE SAME REFERENCE NUMBER

B324

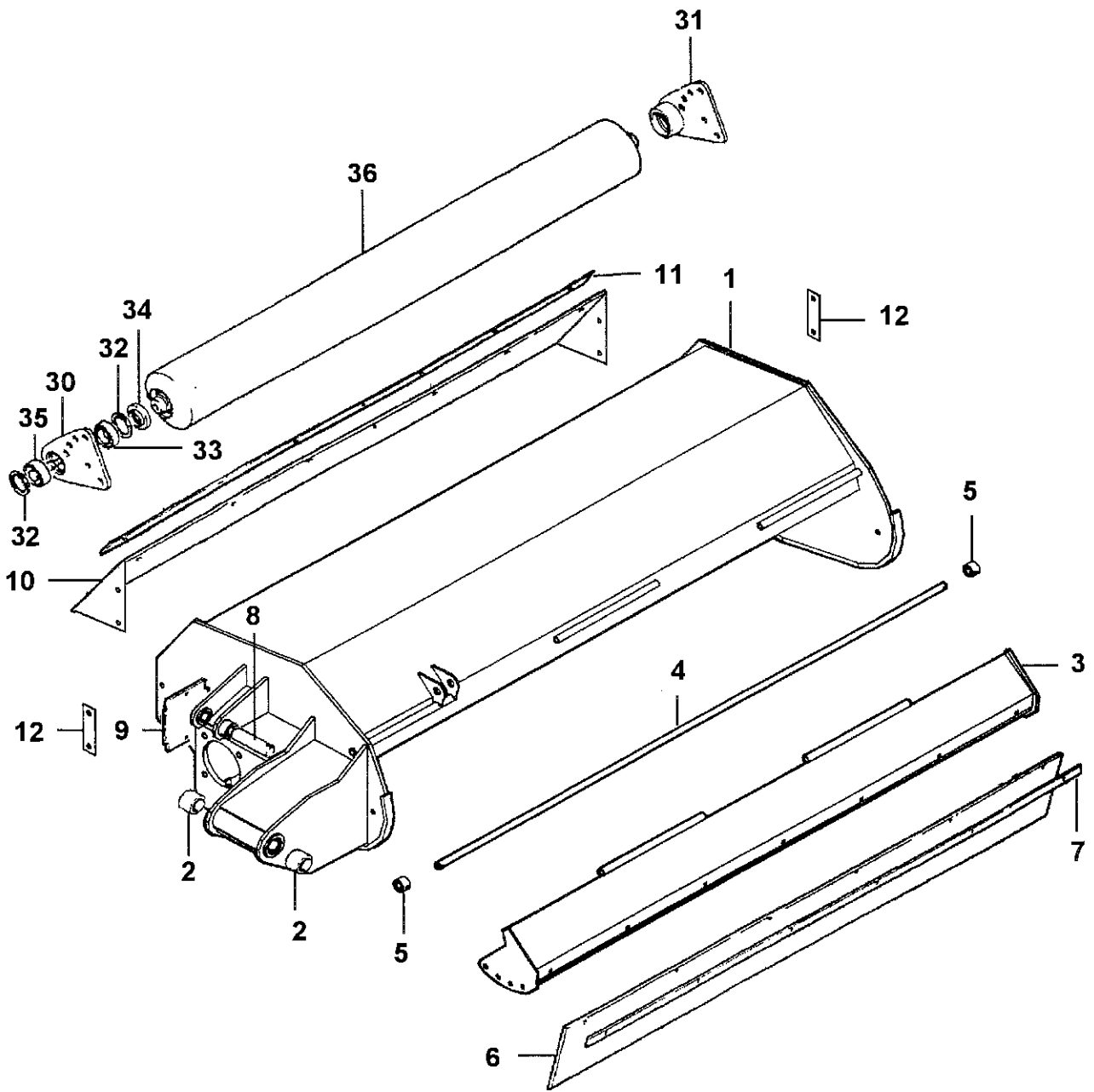

REF	PART NO	DESCRIPTION	QTY
74.753.05/03 COWL ASSY 1600 REAR LH/RH			
*01	42323.03	COWL - REAR LH 1600	1
01	42323.01	COWL - REAR RH 1600	1
01	03.886.01	STUD M16 X 60MM PLATED	4
01	05.281.04	FLAT WASHER 16MM PLATED	4
01	05.282.03	SPRING WASHER 12MM PLATED	6
01	05.282.04	SPRING WASHER 16MM PLATED	4
01	05.286.03	NUT M12 PLATED	6
01	05.286.04	NUT M16 PLATED	4
01	05.839.34	BOLT CUP SQ M12 X 35 (PLATED)	5
01	05.839.36	BOLT CUP SQ M12 X 50 (PLATED)	1
02	08.297.02	BUSH - PLASTIC 47 X 40 X 40	2
*03	42125.02	GUARD - FRONT ADJUSTABLE 1600	1
03	05.282.03	SPRING WASHER 12MM PLATED	2
03	05.286.03	NUT M12 PLATED	2
03	05.839.26	BOLT CUP SQ M12 X 30 (PLATED)	2
*04	42129.04	PIN - PIVOT FRONT GUARD 1600	1
04	05.201.17	TENSION PIN 3MM X 25MM PLATED	2
05	41436.02	SPACER-PIVOT FRONT GUARD	2
*06	42126.03	GUARD - FLEXIBLE FRONT 1600	1
*07	10.120.01	BACKING STRIP	1
07	9293054	BOLT CUP SQUARE M8X25 (PLATE)	7
07	05.282.01	SPRING WASHER 8MM PLATED	7
07	05.286.01	NUT M8 PLATED	7
*08	03.654.54	PIN 30 DIA X 121MM	1
08	05.282.01	SPRING WASHER 8MM PLATED	1
08	05.286.01	NUT M8 PLATED	1
08	05.291.06	BOLT M8 X 55MM PLATED	1
*09	09.249.01	COVER - COWL DRIVE	1
09	05.282.01	SPRING WASHER 8MM PLATED	2
09	30.068.95	SCREW M8 X 12 8.8 GRADE Z/P	2
10	42127.02	GUARD - FLEXIBLE REAR 1600	1
*11	10.120.01	BACKING STRIP	1
11	05.282.01	SPRING WASHER 8MM PLATED	7
11	05.286.01	NUT M8 PLATED	7
11	9293054	BOLT CUP SQUARE M8 X 25 (PLATE)	7
*12	41883.01	CLAMP - GUARD	2
12	05.282.03	SPRING WASHER 12MM PLATED	4
12	05.286.03	NUT M12 PLATED	4
12	05.839.26	BOLT CUP SQ M12 X 30 (PLATED)	4
74.750.02 ROLLER ASSY 150 DIA			
30	41897.01	BRACKET - ROLLER 150 LH	1
31	41897.02	BRACKET - ROLLER 150 RH	1
32	05.959.05	CIRCLIP - INT 62MM DIA	4
33	42954.01	BEARING - D/ROW BALL 30MM BORE	2
34	04.164.04	SEAL-LIP 40DIA X 10MM	2
*35	41851.01	CAP - BEARING RETAINER	2
35	05.953.01	GREASE NIPPLE M6	4
*36	42955.08	ROLLER	1
36	05.234.01	WASHER 44.5 X 13 X 5MM PLATED	2
36	05.282.03	SPRING WASHER 12MM PLATED	2
36	05.625.10	SKT CAPSCREW M12 X 30DOME HD PLT	2

*MAIN PART IN GROUP, RELATED PARTS HAVE SAME REFERENCE NUMBER

B324

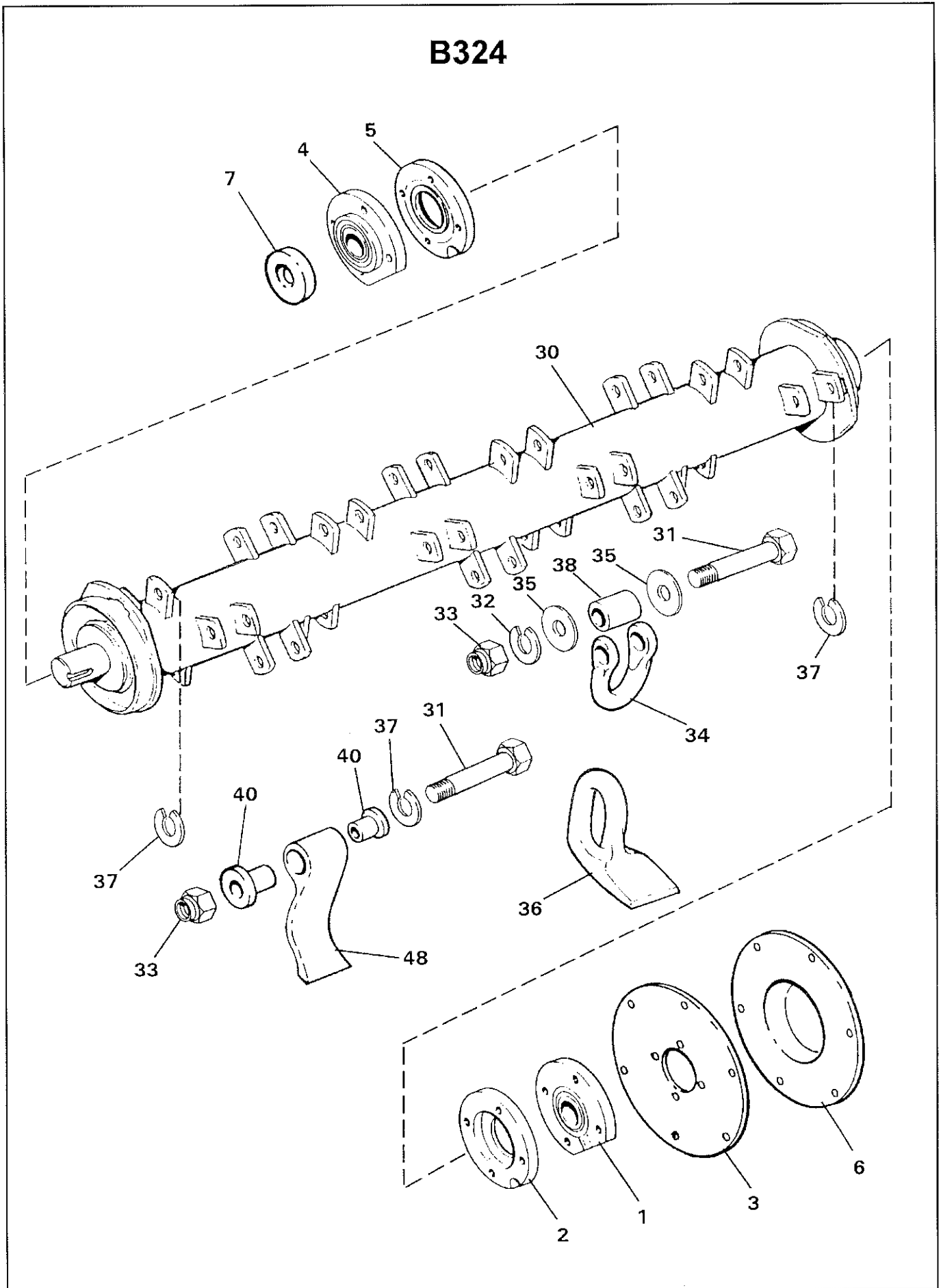

REF	PART NO	DESCRIPTION	QTY
72.474.02 BEARING ASSEMBLY			
*01	06.221.01	BEARING ASSEMBLY 40 - BORE	1
01	05.264.25	SETSCREW M12 X 40MM PLATED	4
01	05.282.03	SPRING WASHER 12MM PLATED	4
*02	06.219.01	DISC-SHIELD	1
02	05.345.05	SOCKET CSK SCREW M12 X 1.75 X 40	1
*03	41.238.02	PLATE - BEARING	1
03	05.264.22	SETSCREW M12 X 25MM PLATED	1
03	05.264.24	SETSCREW M12 X 35MM PLATED	4
03	05.282.03	SPRING WASHER 12MM PLATED	6
03	05.286.03	NUT M12 PLATED	6
*04	06.221.01	BEARING ASSEMBLY 40 - BORE	1
04	05.264.25	SETSCREW M12 X 40MM PLATED	4
04	05.282.03	SPRING WASHER 12MM PLATED	4
*05	06.219.01	DISC-SHIELD	1
05	02.824.01	WASHER 50 O/DX13 I/D X 6MM	1
05	05.264.23	SETSCREW M12 X 30MM PLATED	1
05	05.283.03	SHAKEPROOF WASHER 12MM PLATED	1
06	42324.01	GUARD - NON DRIVE	1
07	07.165.01	PLATE - RETAINING	1
74.751.09 ROTOR SHAFT ASSY 1600			
30	41778.05	ROTOR SHAFT ASSY 4224901/0295901AC	1
31	05.775.10	BOLT - SPECIAL M14 X 94MM	44
32	05.282.08	SPRING WASHER 14MM PLATED	44
33	05.968.06	S.LOCKING NUT M14 (FINE) PLATE	44
34	05.895.01	SHACKLE-FORGED	44
35	05.281.04	FLAT WASHER 16MM PLATED	88
36	02.959.01	FLAIL - FORGED	44
37	05.282.04	SPRING WASHER 16MM PLATED	2
38	02.807.01	SPACER 1"O/D X 16MM I/D X 27MM	44
74.751.10 ROTOR SHAFT ASSY 1600			
30	41778.06	ROTOR SHAFT ASSY 4224901/4215501AC	1
31	05.775.10	BOLT - SPECIAL M14 X 94MM	44
32	05.282.08	SPRING WASHER 14MM PLATED	44
33	05.968.06	S.LOCKING NUT M14 (FINE) PLATE	44
37	05.282.04	SPRING WASHER 16MM PLATED	2
40	09.894.01	COLLAR - PIVOT	88
48	42155.01	FLAIL-SINGLE EDGE (PRO-FLAIL)	44

*MAIN PART IN GROUP, RELATED PARTS HAVE SAME REFERENCE NUMBER

REF	PART NO	DESCRIPTION	QTY
76.023.01 DECALS			
01	09.837.01	DECAL - BOMFORD	2
04	09.843.04	DECAL - LIFT POINT 750 KG	1
05	09.821.21	DECAL - FALLING WING	1
06	09.821.20	DECAL - SHAFT ENTANGLEMENT	1
07	09.821.18	DECAL - THROWN DEBRIS	1
08	09.821.17	DECAL - UNSUPPORTED MACHINE	1
09	09.821.16	DECAL - KEEP OUT ZONE	1
10	09.821.01	DECAL - READ INSTRUCTION BOOK	1
11	09.821.10	DECAL - KEEP NUTS TIGHT	1
12	09.821.08	DECAL - SAFEWORKING ON HEAD	1
13	09.821.07	DECAL - RESIDUAL PRESSURE	1
14	09.821.06	DECAL - SLEW DANGER	1
15	09.821.05	DECAL - CUTTING HEAD DANGER	1
16	09.811.05	DECAL - MAX PTO SPEED 1000	1
17	09.810.02	DECAL - GREASE (40 HOURS)	4
18	09.810.01	DECAL - GREASE (8 HOURS)	9
19	09.852.01	DECAL - ARM FLOAT	-
20	09.980.30	DECAL - B324	2

**SEE PAGES 15 -1 TO 15- 6
FOR ILLUSTRATIONS**

BX364

**REAR MOUNTED
SIDESHIFT**

BX364

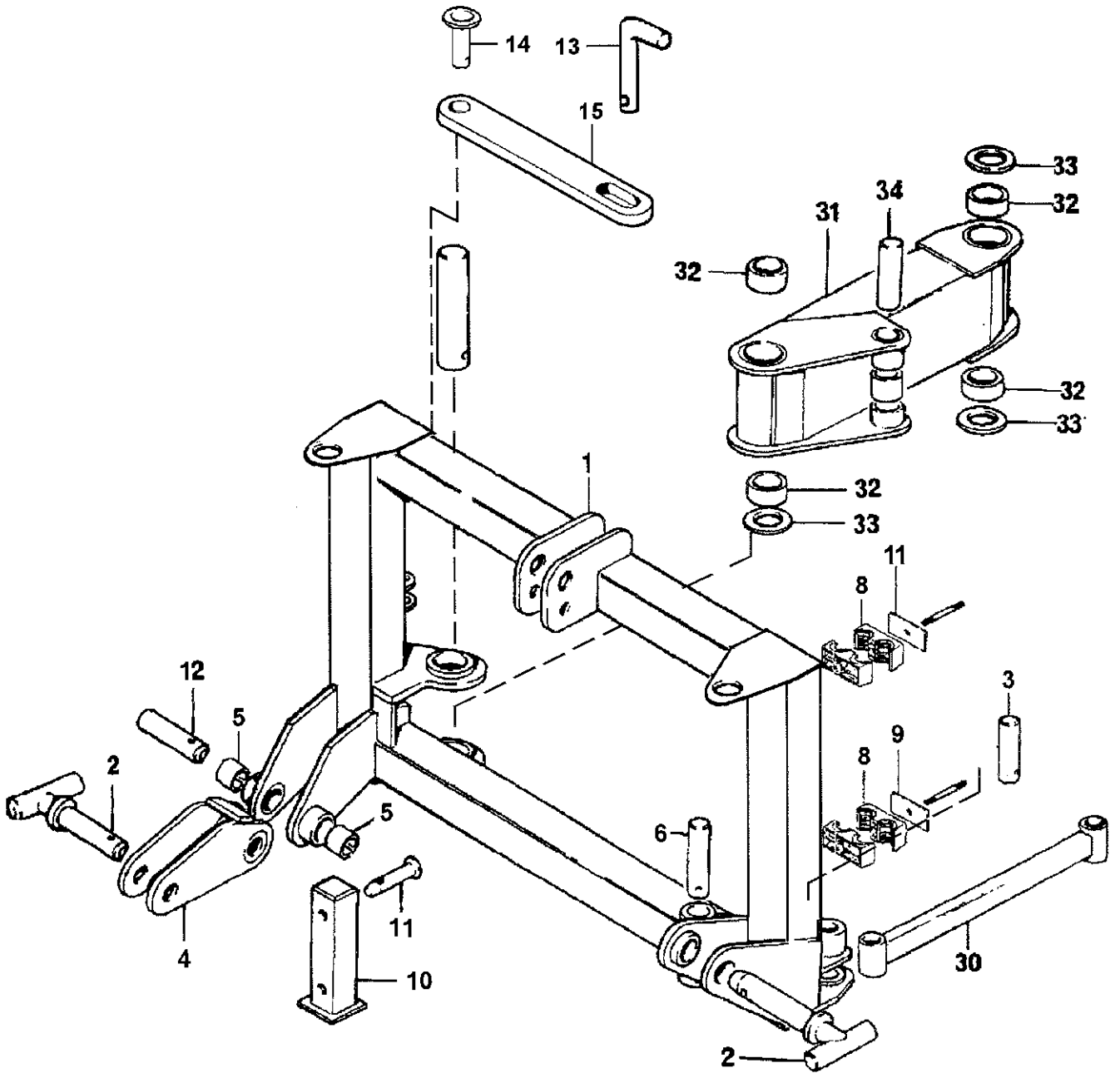

REF	PART NO	DESCRIPTION	QTY
76.019.02 MAINFRAME ASSEMBLY			
*01	42146.02	MAINFRAME RH	1
01	05.227.01	HAMMER DRIVE SCREW NO.6 X 3/8"	2
01	05.774.06	SERIAL NO. PLATE BOMFORD TURNER	1
*02	41.281.01	PIN 1.1/18" DIA - 140	2
02	00.372.01	LINCH PIN	2
*03	03.654.19	PIN 30 DIA X 153	1
03	05.201.07	TENSION PIN 8MM X 45MM PLATED	1
03	05.953.03	GREASE NIPPLE M10	1
04	09.241.01	LINK - BREAKOUT	1
05	02.771.06	TENSION BUSH 35 X 30 X 30	2
*06	03.653.54	PIN 25 DIA X 129	1
06	05.291.05	BOLT, M8 X 50	1
06	05.287.01	NUT, SELF LOCKING, M8	1
06	05.953.03	GREASE NIPPLE M10	1
*07	03.656.74	PIN 40 DIA - 306	1
07	05.282.02	SPRING WASHER 10MM PLATED	1
07	05.286.02	NUT M10 PLATED	1
07	05.292.11	BOLT M10 X 80MM PLATED	1
07	05.953.03	GREASE NIPPLE M10	1
*08	06.430.02	CLAMP HOSE 14 X 14	8
08	04.282.30	STUD M8 X 85 PLATED	2
08	05.281.01	FLAT WASHER 8MM PLATED	2
08	05.282.01	SPRING WASHER 8MM PLATED	2
08	05.286.01	NUT M8 PLATED	2
09	06.418.02	CLAMP PLATE 30 X 6 PLATED	2
10	41332.01	STAND	1
*11	03.652.01	PIN 20 DIA X 90	1
11	00.372.01	LINCH PIN	1
*12	03.654.71	PIN 30 DIA - 173 END	1
12	05.201.07	TENSION PIN 8MM X 45MM PLATED	1
12	05.953.03	GREASE NIPPLE M10	1
*13	03.651.18	PIN 16 DIA X 68MM	1
13	05.964.01	SPRING COTTER 3.6MM DIA	1
*14	03.652.23	PIN 20 DIA X 27	1
14	05.284.14	SPLIT COTTER 5MM X 40MM	1
15	42130.01	STRAP - TRANSPORT	1
74.992.02 SWING LINKS			
30	09.237.01	LINK - SWING	1
31	41.246.02	LINK - SWING RAM	1
32	08.297.02	BUSH - PLASTIC 47 X 40 X 40	4
33	09.232.01	THRUST WASHER	3
*34	03.653.71	PIN 25 DIA X 232MM	1
34	05.201.07	TENSION PIN 8MM X 45MM PLATED	1
34	05.953.01	GREASE NIPPLE M6	1
35	09.235.02	SPACER 40 O/D X 25.5 I/D - 26	1

*MAIN PART IN GROUP, RELATED PARTS HAVE SAME REFERENCE NUMBER

BX364

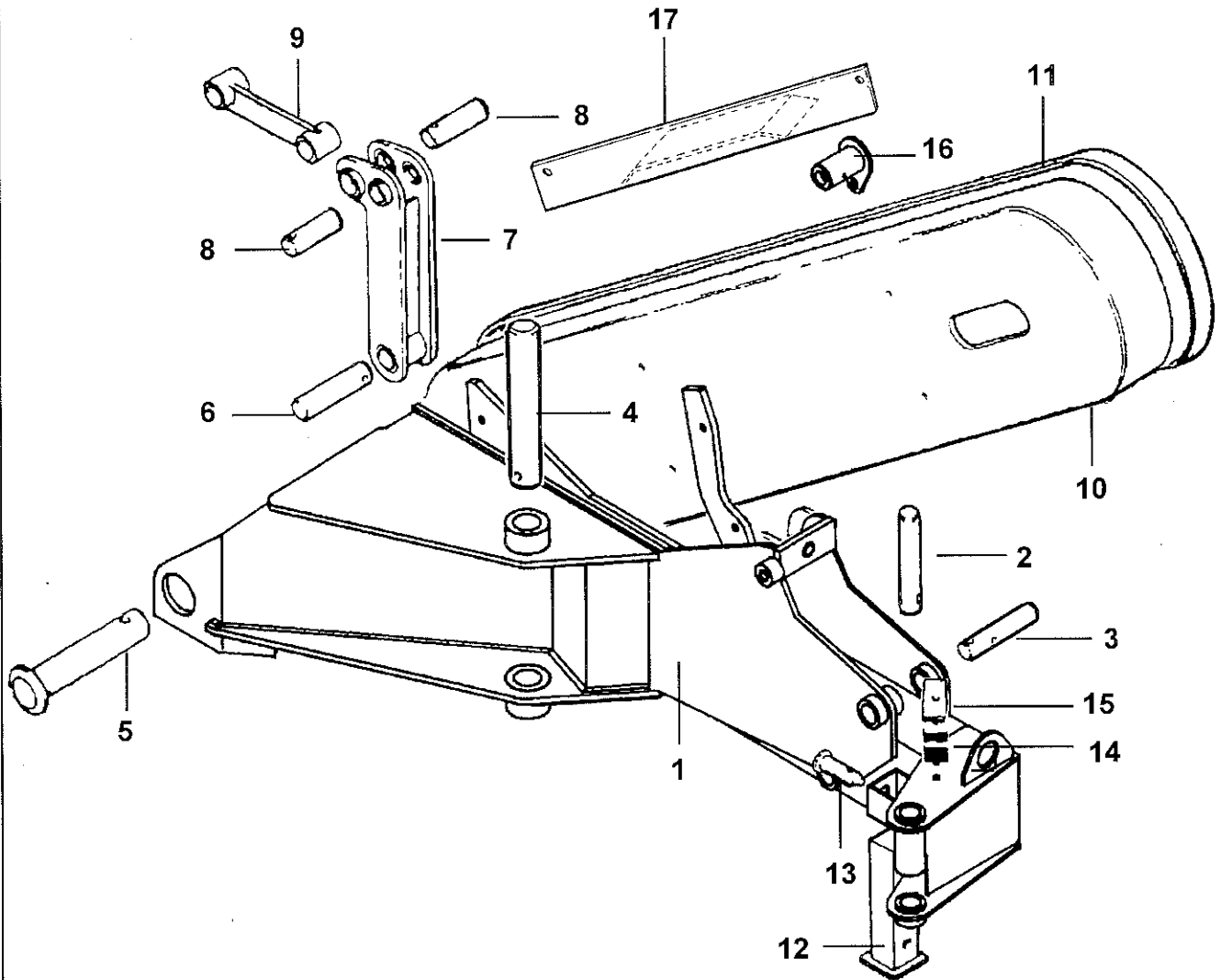

REF	PART NO	DESCRIPTION	QTY
76.020.01 ARM ASSEMBLY			
01	41.256.01	ARM RH <i>(up to Serial No. 1167J/98)</i>	1
01	41.256.04	ARM RH <i>(from Serial No. 1168J/98)</i>	1
*02	03.654.70	PIN 30 DIA - 194	1
02	05.201.07	TENSION PIN 8MM X 45MM PLATED	1
02	05.953.01	GREASE NIPPLE M6	1
*03	03.654.69	PIN 30 DIA - 150	1
03	05.282.01	SPRING WASHER 8MM PLATED	1
03	05.286.01	NUT M8 PLATED	1
03	05.291.06	BOLT M8 X 55MM PLATED	1
*04	03.656.75	PIN 40 DIA - 333	1
04	05.282.02	SPRING WASHER 10MM PLATED	1
04	05.286.02	NUT M10 PLATED	1
04	05.292.11	BOLT M10 X 80MM PLATED	1
04	05.953.03	GREASE NIPPLE M10	1
*05	03.656.73	PIN 40 DIA - 310	1
05	05.282.02	SPRING WASHER 10MM PLATED	1
05	05.286.02	NUT M10 PLATED	1
05	05.292.11	BOLT M10 X 80MM PLATED	1
05	05.953.03	GREASE NIPPLE M10	1
*06	02.837.01	PIN 30 DIA X 135MM	1
06	04.175.01	STUD M10 X 29MM	1
06	05.281.02	FLT WASHER 10MM PLATED FORM C	1
06	05.968.02	SELF LOCKING NUT M10 (FINE)	1
*07	41.241.01	LINK - RAM	1
07	05.953.01	GREASE NIPPLE M6	1
*08	03.654.53	PIN 30 DIA X 92MM	2
08	05.201.11	TENSION PIN 5MM X 45MM PLATED	2
*09	41.060.01	LINK - COWL	1
09	05.953.01	GREASE NIPPLE M6	2
*10	41764.02	GUARD - REAR RH	1
10	05.264.12	SETSCREW M10 X 25MM PLATED	4
10	05.282.02	SPRING WASHER 10MM PLATED	4
*11	41775.01	GUARD - COVER	1
11	05.264.11	SETSCREW M10 X 20MM PLATED	4
11	05.282.02	SPRING WASHER 10MM PLATED	4
12	41332.01	STAND	1
*13	03.652.01	PIN 20 DIA X 90	1
13	00.372.01	LINCH PIN	1
*14	06.430.02	CLAMP HOSE 14 X 14	2
14	04.282.32	STUD M8 X 52	1
14	05.281.01	FLAT WASHER 8MM PLATED	1
14	05.282.01	SPRING WASHER 8MM PLATED	1
14	05.286.01	NUT M8 PLATED	1
15	06.418.02	CLAMP PLATE 30 X 6 PLATED	1
*16	42652.04	PIN 40 DIA X 70	1
16	05.264.21	SETSCREW M12 X 20MM PLATED	1
16	05.281.03	FLAT WASHER 12MM PLATED	1
16	05.282.03	SPRING WASHER 12MM PLATED	1
16	05.953.01	GREASE NIPPLE	1
17	43008.01	BRACKET-BELT SUPPORT	1

*MAIN PART IN GROUP, RELATED PARTS HAVE SAME REFERENCE NUMBER

BX364

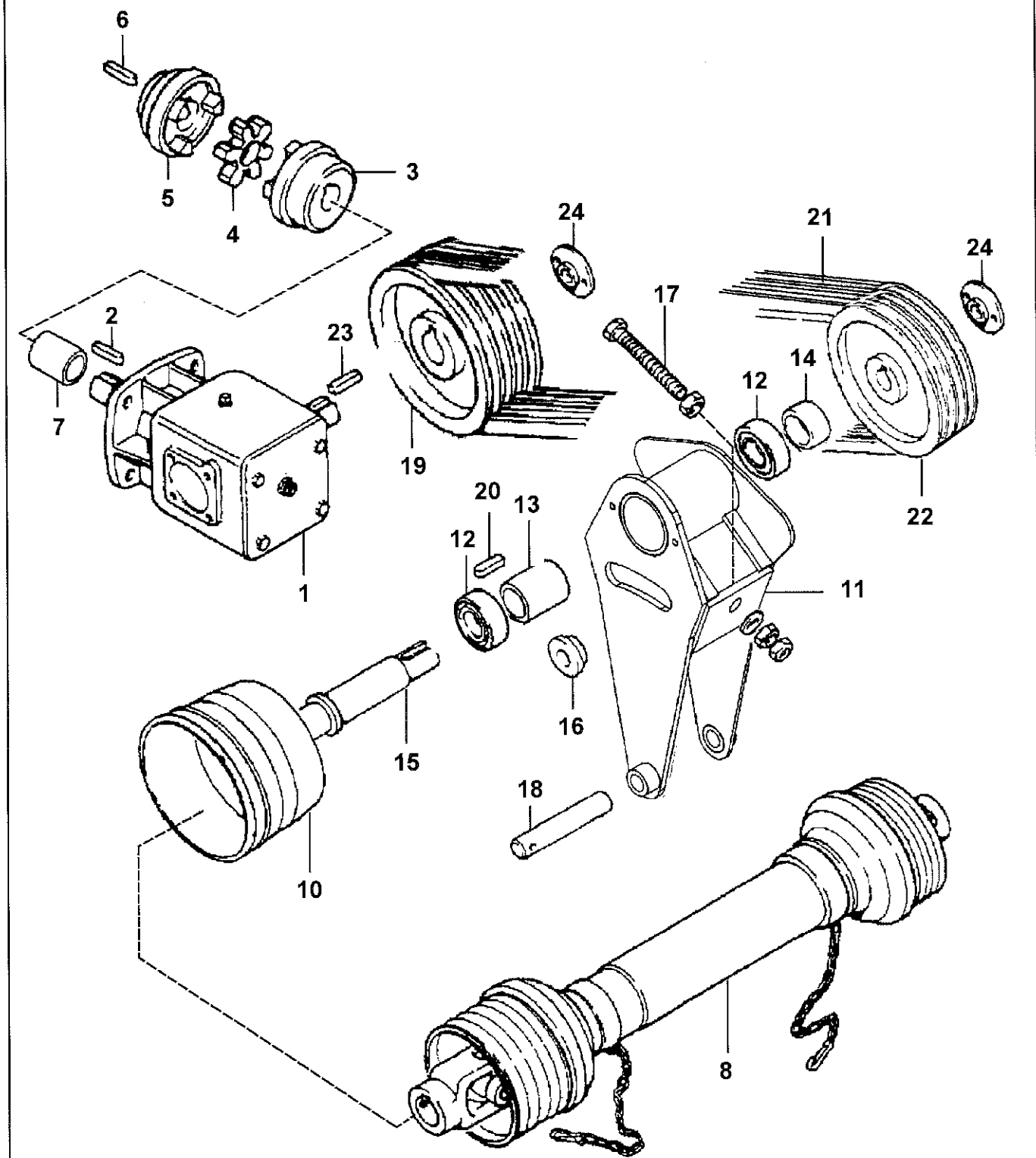

REF	PART NO	DESCRIPTION	QTY
76.027.01 DRIVE BRACKET, PULLEYS & BELTS			
*10	09.236.01	GUARD - PLASTIC PTO	1
10	05.264.11	SETSCREW M10 X 20MM PLATED	2
10	05.281.02	FLT WASHER 10MM PLATED FORM C	2
10	05.282.02	SPRING WASHER 10MM PLATED	2
11	41768.04	BRACKET - DRIVE RH (<i>up to Serial No. 1167J/98</i>)	1
11	41768.06	BRACKET - DRIVE RH (<i>from Serial No. 1168J/98</i>)	1
12	03.007.06	BEARING - BALL 40MM BORE	2
13	41.258.01	SPACER 50 OD X 40.2 ID - 94	1
14	09.264.01	SPACER 50 O/D X 40.2 I/D - 26	1
*15	41730.01	SHAFT - PULLEY/PTO	1
15	05.264.24	SETSCREW M12 X 35MM PLATED	1
15	05.282.03	SPRING WASHER 12MM PLATED	1
*16	09.263.01	COLLAR - CLAMP	1
16	05.264.34	SETSCREW M16 X 35MM PLATED	1
16	05.282.04	SPRING WASHER 16MM PLATED	1
*17	41769.01	BOLT - ADJUSTMENT	1
17	05.264.02	SETSCREW M8 X 25MM PLATED	4
17	05.281.04	FLAT WASHER 16MM PLATED	4
17	05.282.01	SPRING WASHER 8MM PLATED	4
17	05.286.04	NUT M16 PLATED	3
*18	03.653.63	PIN 25 X 186	1
18	05.201.07	TENSION PIN 8MM X 45MM PLATED	1
19	05.388.01	SCKT GRUBSCREW M8 X 25MM CONE PT	1
19	41.245.01	PULLEY - 250 PCD X 4 SPB	1
20	05.960.03	KEY-SEP 10MM X 8MM X 50MM	1
21	05.299.51	BELT XPB 2500 QUAD POWER GATES	4
*22	41.244.01	PULLEY - 180 X 4 SPB	1
22	05.388.01	SCKT GRUBSCREW M8 X 25MM CONE PT	1
23	05.960.22	KEY-REP 10 X 8 X 58	1
24	09.297.01	WASHER 75 O/D X 13 I/D X 6	2
74.993.01 GEARBOX ASSEMBLY			
*01	09.250.04	GEARBOX ASSEMBLY COMER RH	1
01	02.824.01	WASHER 50 O/DX13 I/D X 6MM	1
01	05.264.24	SETSCREW M12 X 35MM PLATED	1
01	05.282.03	SPRING WASHER 12MM PLATED	1
02	05.960.22	KEY-REP 10 X 8 X 58	1
*03	41.250.02	HUB-COUPLING 35MM BORE	1
03	05.388.01	SCKT GRUBSCREW M8 X 25MM CONE PT	2
04	41.250.04	DRIVE - COUPLING	1
05	41.250.03	HUB-COUPLING 45MM BORE	1
06	05.960.13	KEY-S/REP 14MM X 9MM X 45MM	1
07	42613.02	SPACER 50 X 35.5 - 25MM	1
72.478.01 PTO SHAFT ASSEMBLY			
*08	41624.06	PTO SHAFT ASSY 810MM C/C	1
08	41624.31	CROSS JOURNAL SET	-
08	41624.34	COMPLETE SHIELD	-

*MAIN PART IN GROUP, RELATED PARTS HAVE SAME REFERENCE NUMBER

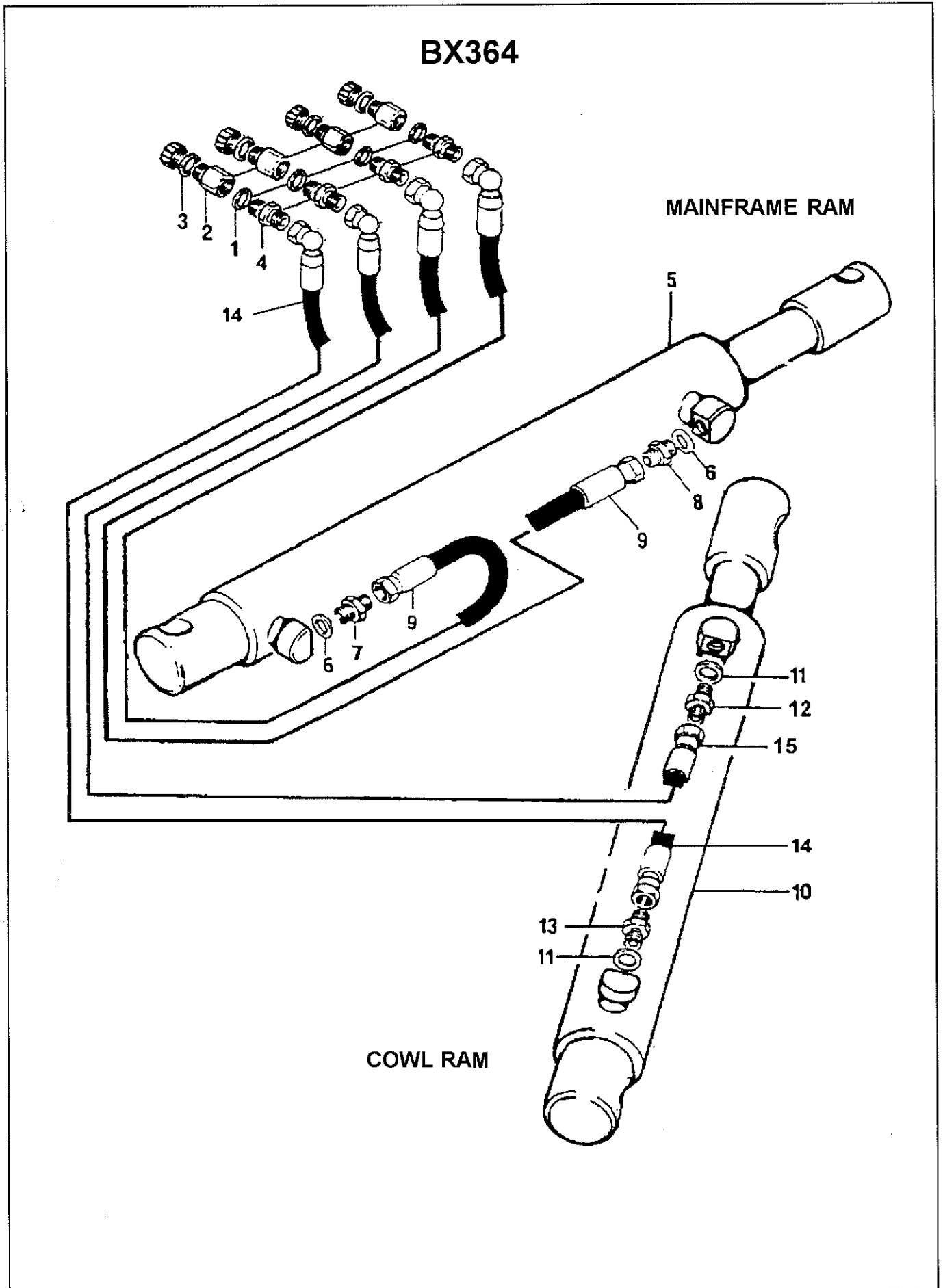

REF	PART NO	DESCRIPTION	QTY
74.984.02 RAMS/HOSES			
01	05.290.05	BONDED SEAL 1/2"BSP	4
*02	05.225.01	ADAPTOR-RDCG.1/2"BSP X 3/8"BSP	4
02	05.300.03	PLUG-PLASTIC 1/2"BSP FEMALE	4
03	05.290.04	BONDED SEAL 3/8"BSP	4
04	08.955.06	ADAPTOR 3/8"BSP X 9/16"-18 JIC	4
*05	41.042.03	RAM ASSY - 50 BORE/35 ROD X	1
05	41.042.01	SEAL KIT - 41.042.XX RAMS.	-
06	05.290.04	BONDED SEAL 3/8"BSP	2
07	46518.27	RESTRICTOR 3/8"BSP X 9/16" JIC (1.70)	1
08	46518.23	RESTRICTOR 3/8" X 9/16"JIC (1.27)	1
09	08.957.32	HOSE 1/4"BORE X 2400 JIC 90 X ST	1
*10	09.993.04	RAM ASSY DIA 80 BORE	1
10	05.953.01	GREASE NIPPLE M6	2
10	09.993.01	SEAL KIT FOR 09.993.XX RAMS	-
11	05.290.04	BONDED SEAL 3/8" BSP	2
12	46518.32	RESTRICTOR 3/8" X 9/16" JIC(1.00)	1
13	08.955.06	ADAPTOR 3/8"BSP X 9/16"-18 JIC	1
14	08.957.37	HOSE 1/4"BORE X2900MM JIC90 X ST	1
15	08.957.42	HOSE 1/4"BOREX3400MM JIC 90 X ST	1

*MAIN PART IN GROUP, RELATED PARTS HAVE SAME REFERENCE NUMBER

BX364

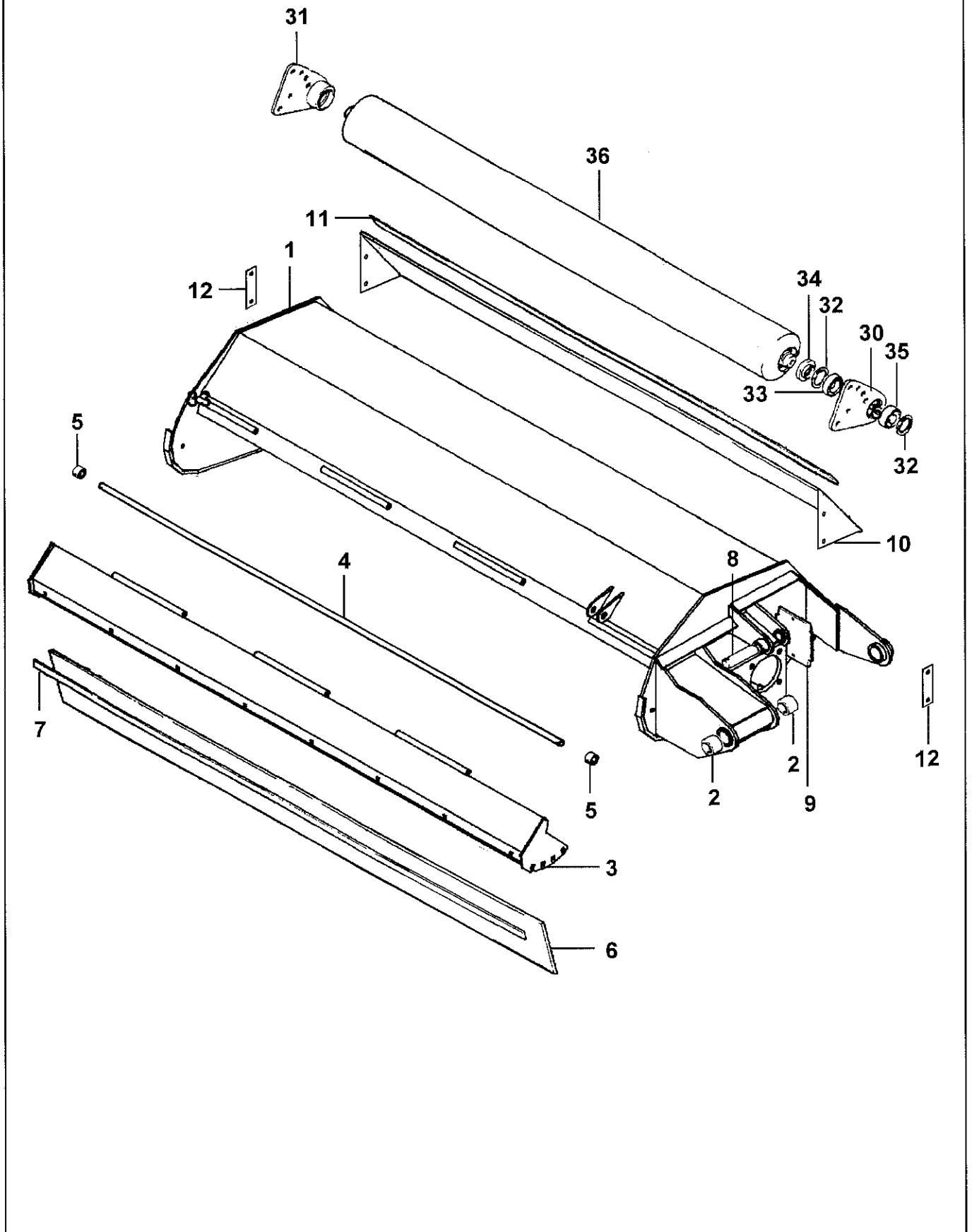

REF	PART NO	DESCRIPTION	QTY
74.986.03 COWL ASSEMBLY REAR 2000			
*01	42141.01	COWL - 2000	1
*01	42141.02	COWL - 2000	1
01	03.886.01	STUD M16 X 60MM PLATED	4
01	05.281.04	FLAT WASHER 16MM PLATED	4
01	05.282.04	SPRING WASHER 16MM PLATED	4
01	05.286.04	NUT M16 PLATED	4
02	08.297.02	BUSH - PLASTIC 47 X 40 X 40	3
*03	42143.01	GUARD - FRONT ADJUSTABLE 2000	1
03	05.282.03	SPRING WASHER 12MM PLATED	2
03	05.286.03	NUT M12 PLATED	2
03	05.839.26	BOLT CUP SQ M12 X 30 (PLATED)	2
*04	42129.05	PIN - PIVOT FRONT GUARD 2000	1
04	05.201.17	TENSION PIN 3MM X 25MM PLATED	2
05	41436.02	SPACER-PIVOT FRONT GUARD	2
06	42126.02	GUARD - FLEXIBLE 2000	1
*07	41.237.01	BACKING STRIP	1
07	05.287.01	SELF-LOCKING NUT M8 PLATED	8
07	9293054	BOLT CUP SQUARE M8X25 (PLATE)	8
*08	03.654.54	PIN 30 DIA X 121MM	1
08	05.282.01	SPRING WASHER 8MM PLATED	1
08	05.286.01	NUT M8 PLATED	1
08	05.291.06	BOLT M8 X 55MM PLATED	1
*09	41.070.01	COVER - COWL DRIVE	1
09	05.282.01	SPRING WASHER 8MM PLATED	2
09	30.068.95	SCREW M8 X 12 8.8 GRADE Z/P	2
10	41452.01	GUARD - FLEXIBLE 2000	1
*11	41.237.01	BACKING STRIP	1
11	05.287.01	SELF-LOCKING NUT M8 PLATED	8
11	9293054	BOLT CUP SQUARE M8 X 25 (PLATE)	8
*12	41418.01	CLAMP - GUARD	2
12	05.282.03	SPRING WASHER 12MM PLATED	4
12	05.286.03	NUT M12 PLATED	4
12	05.839.26	BOLT CUP SQ M12 X 30 (PLATED)	4
74.985.03 ROLLER ASSEMBLY 2000			
*30	42144.01	BRACKET - ROLLER 150 LH	1
30	05.282.03	SPRING WASHER 12MM PLATED	3
30	05.286.03	NUT M12 PLATED	3
30	05.839.34	BOLT CUP SQ M12 X 35 (PLATED)	2
30	05.839.35	BOLT CUP SQ M12 X 40 (PLATED)	1
*31	42144.02	BRACKET - ROLLER 150 RH	1
31	05.282.03	SPRING WASHER 12MM PLATED	3
31	05.286.03	NUT M12 PLATED	3
31	05.839.34	BOLT CUP SQ M12 X 35 (PLATED)	2
31	05.839.35	BOLT CUP SQ M12 X 40 (PLATED)	1
32	05.959.05	CIRCLIP - INT 62MM DIA	4
33	42954.01	BEARING - D/ROW BALL 30MM BORE	2
34	04.164.04	SEAL-LIP 40DIA X 10MM	2
*35	41851.01	CAP - BEARING RETAINER	2
35	05.953.01	GREASE NIPPLE M6	4
*36	42955.07	ROLLER 6" DIA - 2000	1
36	05.234.01	WASHER 44.5 X 13 X 5MM PLATED	2
36	05.282.03	SPRING WASHER 12MM PLATED	2
36	05.625.10	SOCKET CAPSCRW M12 X 30DOME HD PLT	2

*MAIN PART IN GROUP, RELATED PARTS HAVE SAME REFERENCE NUMBER

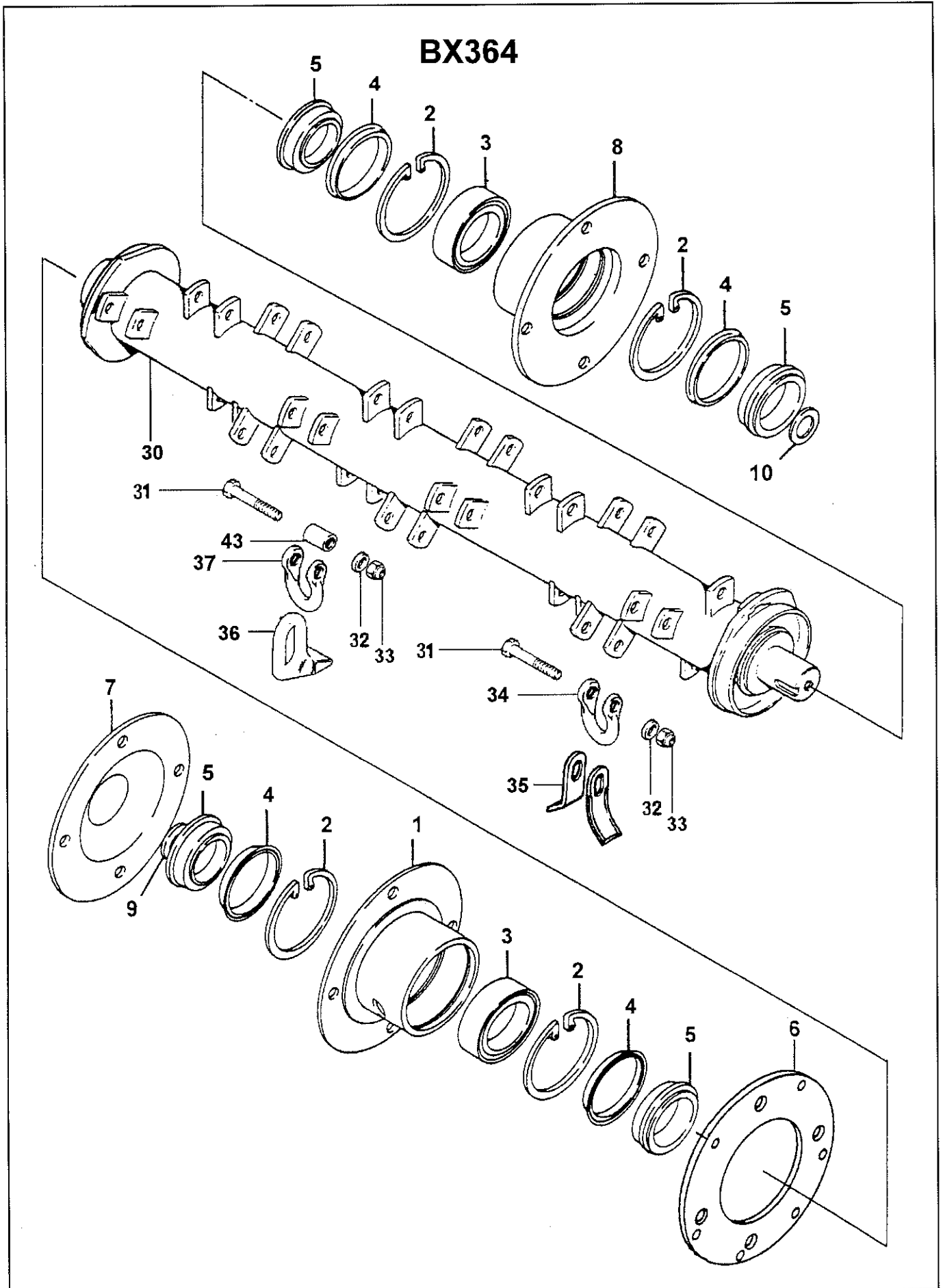

REF	PART NO	DESCRIPTION	QTY
74.994.01 BEARING ASSEMBLY			
*01	04.268.01	HOUSING-BEARING	1
01	05.264.24	SETSCREW M12 X 35MM PLATED	4
01	05.282.03	SPRING WASHER 12MM PLATED	4
01	05.286.03	NUT M12 PLATED	4
01	05.953.03	GREASE NIPPLE M10	1
02	05.959.07	CIRCLIP - INT 85MM DIA	4
03	04.163.04	BEARING-SPH.ROLLER 45MM BORE	2
04	06.909.01	SPACER-SEAL	4
05	06.910.01	COLLAR-SEAL	4
*06	41.238.01	PLATE - BEARING	1
06	05.264.23	SETSCREW M12 X 30MM PLATED	5
06	05.282.03	SPRING WASHER 12MM PLATED	5
06	05.286.03	NUT M12 PLATED	5
07	00.876.02	BEARING COVER	1
*08	41.240.01	BEARING HOUSING DRIVE	1
08	05.264.24	SETSCREW M12 X 35MM PLATED	4
08	05.282.03	SPRING WASHER 12MM PLATED	4
08	05.286.03	NUT M12 PLATED	4
*09	04.252.01	WASHER 65 O/DX17 I/DX8MM	1
09	05.264.33	SETSCREW M16 X 30MM PLATED	1
09	05.283.04	SHAKEPROOF WASHER 16MM PLATED	1
*10	41.257.01	WASHER 50 X 6	1
10	05.345.08	SOCKET CSK SCREW M16 X 2.0 X 30	1
76.119.01 ROTOR SHAFT ASSEMBLY			
30	41329.01	ROTOR SHAFT ASSY 4129901/0295901	1
31	05.775.10	BOLT - SPECIAL M14 X 94MM	54
32	05.282.08	SPRING WASHER 14MM PLATED	54
33	05.968.06	S.LOCKING NUT M14 (FINE) PLATE	54
34	09.517.01	SHACKLE - STANDARD	54
35	09.528.01	FLAIL 39 X 8	108
76.021.01 ROTOR SHAFT ASSEMBLY			
30	41458.01	ROTOR SHAFT ASSY 4129901/0295901	1
31	05.775.10	BOLT - SPECIAL M14 X 94MM	54
32	05.282.08	SPRING WASHER 14MM PLATED	54
33	05.968.06	S.LOCKING NUT M14 (FINE) PLATE	54
36	02.959.01	FLAIL - FORGED	54
37	09.518.01	SHACKLE - LONG	54
43	41725.01	SPACER 1"O/D X 16 - 22	54

*MAIN PART IN GROUP, RELATED PARTS HAVE SAME REFERENCE NUMBER

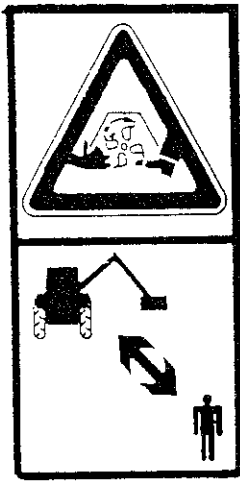

09.821.05

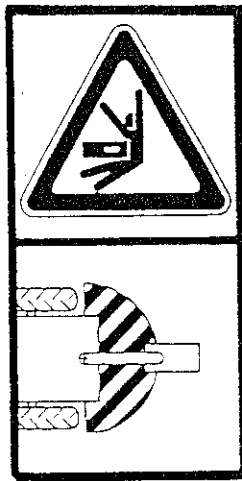

09.821.06

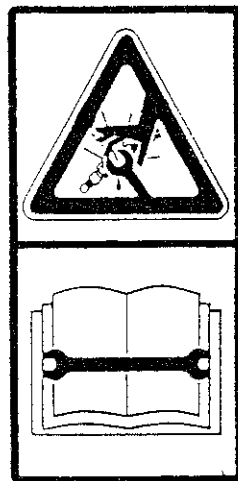

09.821.07

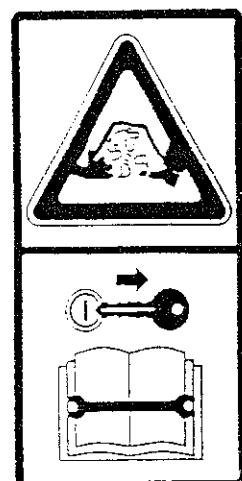

09.821.08



09.821.10

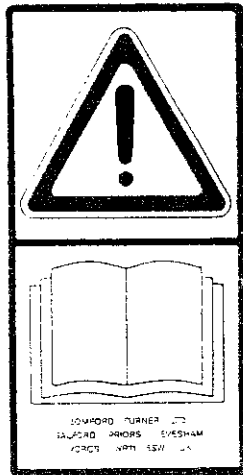

09.821.01

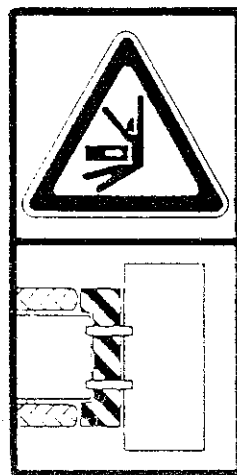

09.821.16



09.821.17



09.821.18



09.821.20



09.821.21

REF	PART NO	DESCRIPTION	QTY
76.023.01 DECALS			
01	09.837.01	DECAL - BOMFORD	2
04	09.843.04	DECAL - LIFT POINT 750 KG	1
05	09.821.21	DECAL - FALLING WING	1
06	09.821.20	DECAL - SHAFT ENTANGLEMENT	1
07	09.821.18	DECAL - THROWN DEBRIS	1
08	09.821.17	DECAL - UNSUPPORTED MACHINE	1
09	09.821.16	DECAL - KEEP OUT ZONE	1
10	09.821.01	DECAL - READ INSTRUCTION BOOK	1
11	09.821.10	DECAL - KEEP NUTS TIGHT	1
12	09.821.08	DECAL - SAFEWORKING ON HEAD	1
13	09.821.07	DECAL - RESIDUAL PRESSURE	1
14	09.821.06	DECAL - SLEW DANGER	1
15	09.821.05	DECAL - CUTTING HEAD DANGER	1
16	09.811.05	DECAL - MAX PTO SPEED 1000	1
17	09.810.02	DECAL - GREASE (40 HOURS)	4
18	09.810.01	DECAL - GREASE (8 HOURS)	9
19	09.852.01	DECAL - ARM FLOAT	-
20	09.980.32	DECAL - BX 364	2

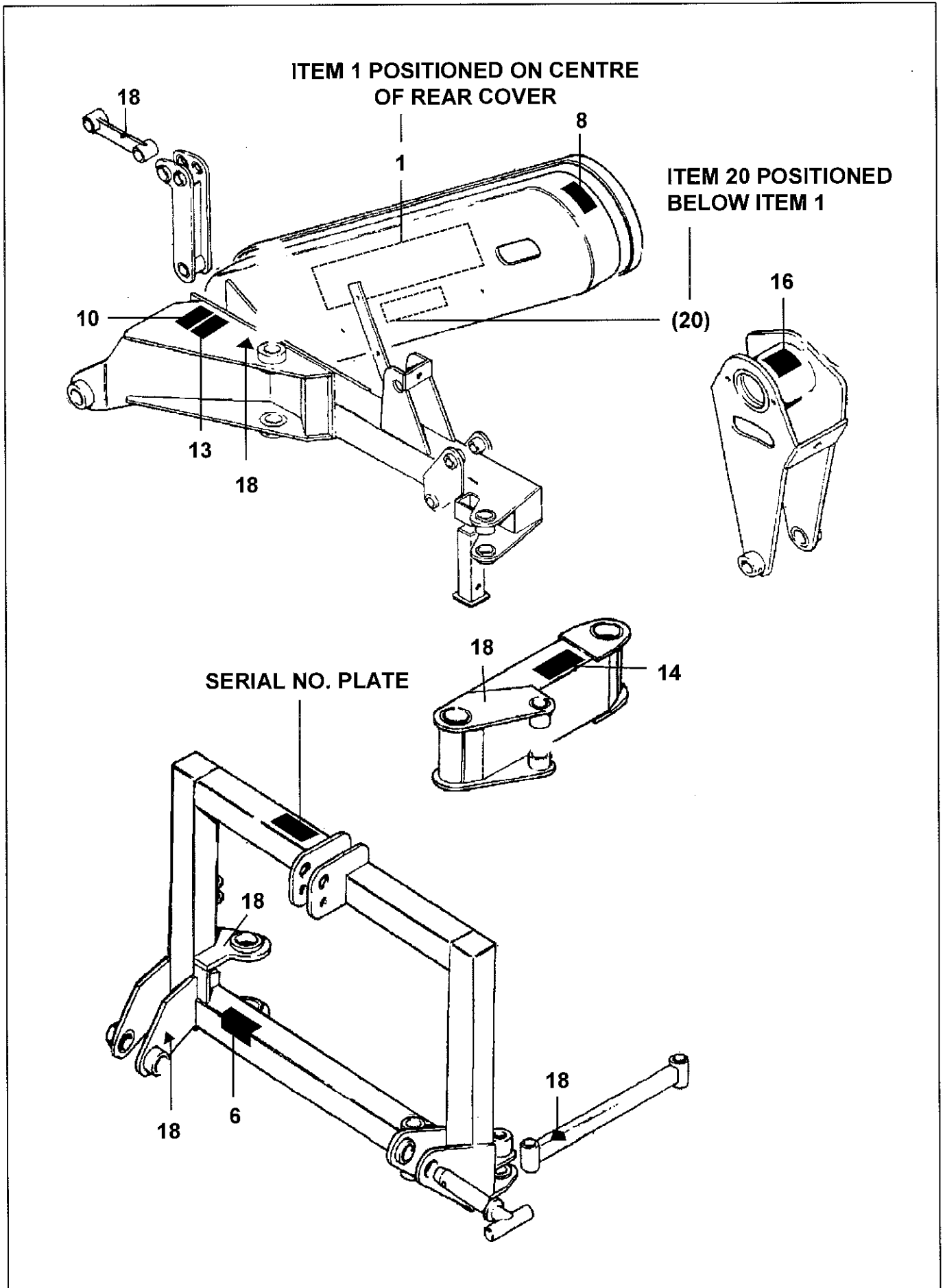

REF	PART NO	DESCRIPTION	QTY
76.023.01 DECALS			
01	09.837.01	DECAL - BOMFORD	2
04	09.843.04	DECAL - LIFT POINT 750 KG	1
05	09.821.21	DECAL - FALLING WING	1
06	09.821.20	DECAL - SHAFT ENTANGLEMENT	1
07	09.821.18	DECAL - THROWN DEBRIS	1
08	09.821.17	DECAL - UNSUPPORTED MACHINE	1
09	09.821.16	DECAL - KEEP OUT ZONE	1
10	09.821.01	DECAL - READ INSTRUCTION BOOK	1
11	09.821.10	DECAL - KEEP NUTS TIGHT	1
12	09.821.08	DECAL - SAFEWORKING ON HEAD	1
13	09.821.07	DECAL - RESIDUAL PRESSURE	1
14	09.821.06	DECAL - SLEW DANGER	1
15	09.821.05	DECAL - CUTTING HEAD DANGER	1
16	09.811.05	DECAL - MAX PTO SPEED 1000	1
17	09.810.02	DECAL - GREASE (40 HOURS)	4
18	09.810.01	DECAL - GREASE (8 HOURS)	9
19	09.852.01	DECAL - ARM FLOAT	-
20	09.980.32	DECAL - BX364	2

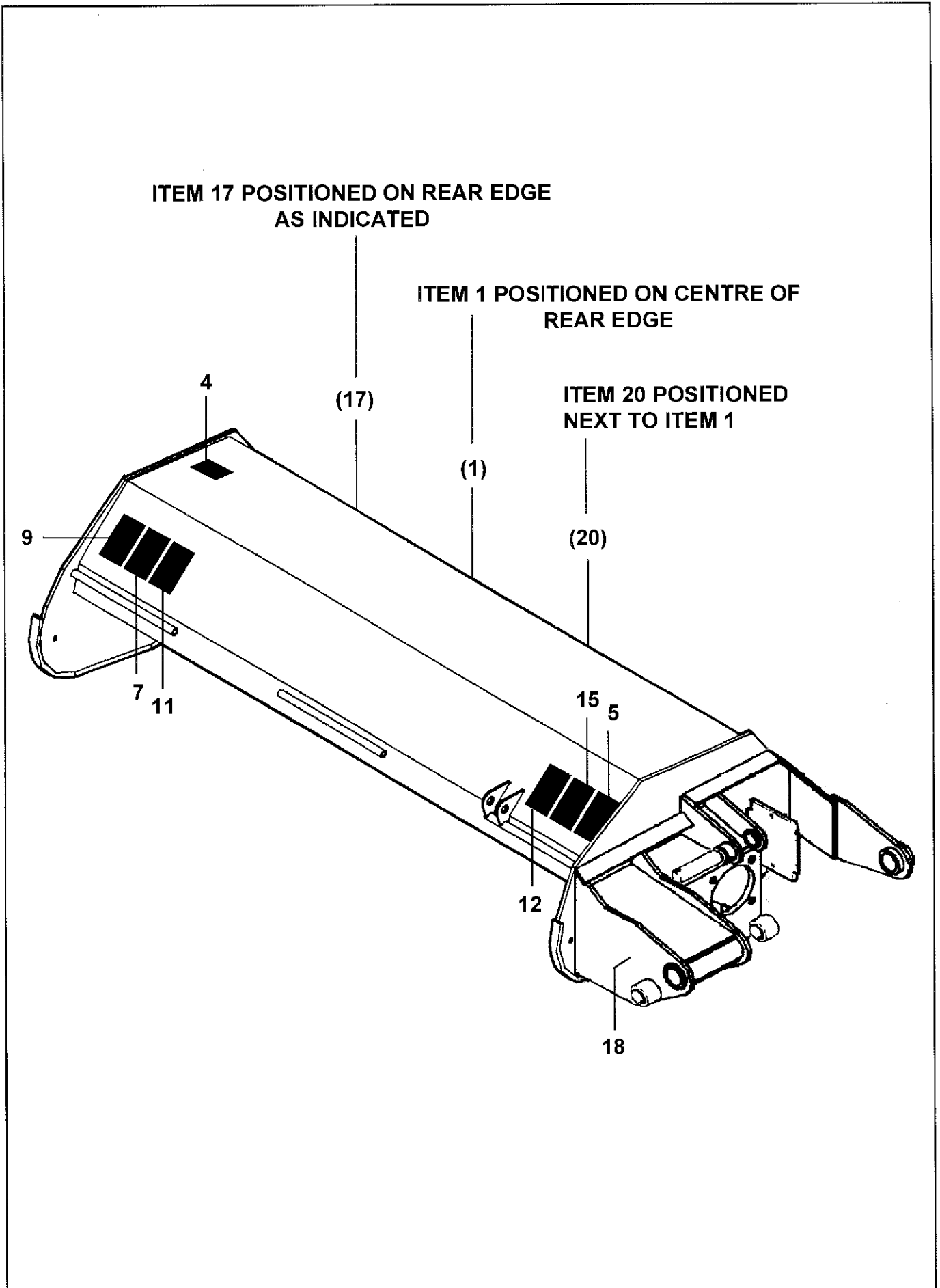

REF	PART NO	DESCRIPTION	QTY
76.023.01 DECALS			
01	09.837.01	DECAL - BOMFORD	2
04	09.843.04	DECAL - LIFT POINT 750 KG	1
05	09.821.21	DECAL - FALLING WING	1
06	09.821.20	DECAL - SHAFT ENTANGLEMENT	1
07	09.821.18	DECAL - THROWN DEBRIS	1
08	09.821.17	DECAL - UNSUPPORTED MACHINE	1
09	09.821.16	DECAL - KEEP OUT ZONE	1
10	09.821.01	DECAL - READ INSTRUCTION BOOK	1
11	09.821.10	DECAL - KEEP NUTS TIGHT	1
12	09.821.08	DECAL - SAFEWORKING ON HEAD	1
13	09.821.07	DECAL - RESIDUAL PRESSURE	1
14	09.821.06	DECAL - SLEW DANGER	1
15	09.821.05	DECAL - CUTTING HEAD DANGER	1
16	09.811.05	DECAL - MAX PTO SPEED 1000	1
17	09.810.02	DECAL - GREASE (40 HOURS)	4
18	09.810.01	DECAL - GREASE (8 HOURS)	9
19	09.852.01	DECAL - ARM FLOAT	-
20	09.980.32	DECAL - BX364	2

**OPTIONAL
EXTRAS**

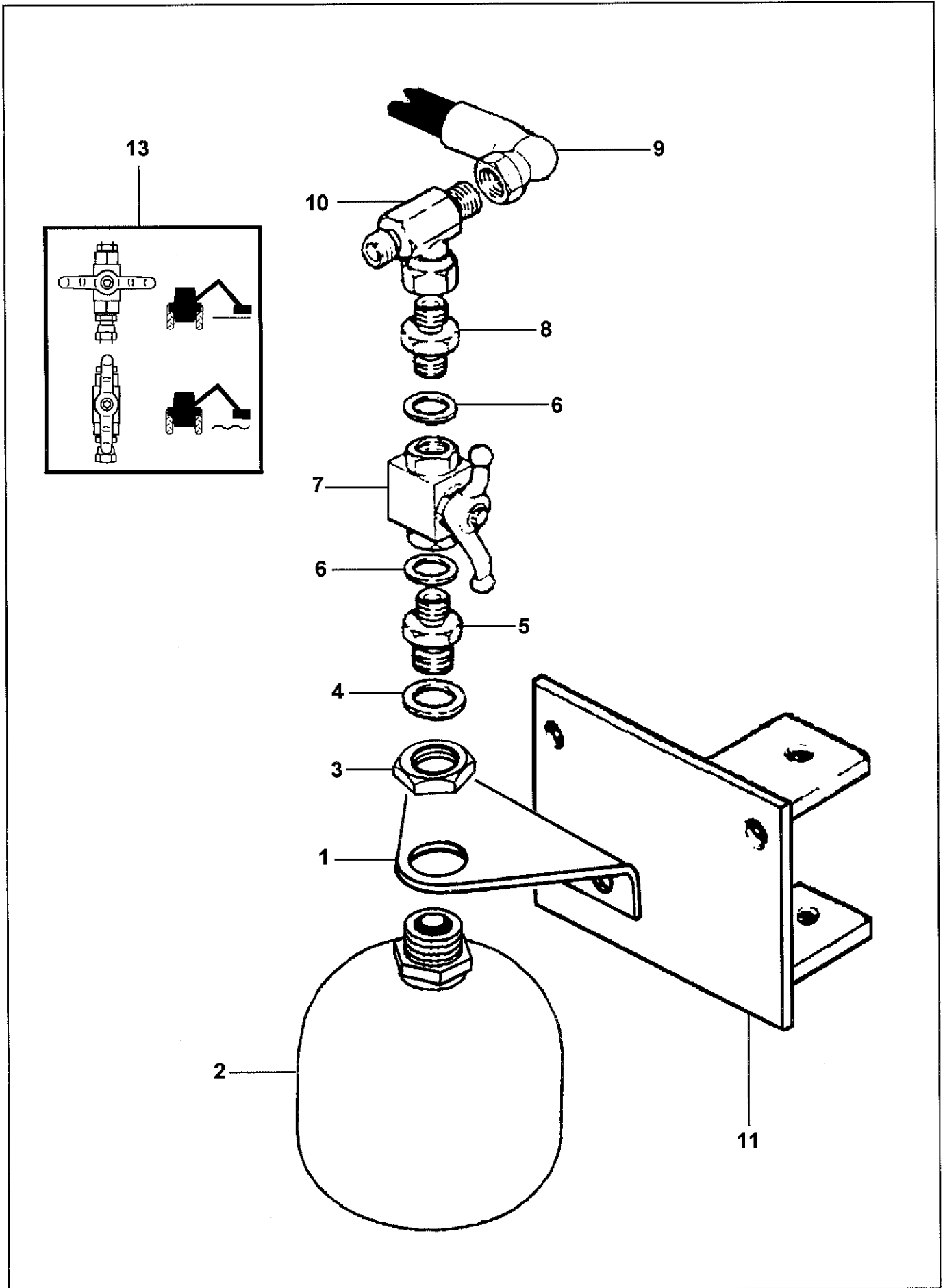

REF	PART NO	DESCRIPTION	QTY
72.657.02 ARM FLOAT B324 ETC. JIC7504			
01*	43239.01	BRACKET	1
01	05.264.13	SETSCREW M10 X 30MM PLATED*	2
01	05.282.02	SPRING WASHER 10MM PLATED*	2
01	05.286.02	NUT M10 PLATED*	2
02	41451.02	ACCUMULATOR	1
03	8126035	M33 NUT, BULKHEAD	1
04	05.290.05	BONDED SEAL 1/2"BSP	1
05	05.123.01	ADAPTOR 1/2" BSP X 3/8" BSP	1
06	05.290.04	BONDED SEAL 3/8"BSP	2
07	08.200.01	VALVE - ISOLATING 3/8" BSP	1
08	08.955.06	ADAPTOR 3/8"BSP X 9/16"-18 JIC	1
09	08.957.20	HOSE 1/4"BOREX1200MM JIC 90XST	1
10	04.056.31	ADAPTOR TEE 9/16" JIC FMM	1
11	05.282.02	SPRING WASHER 10MM PLATED*	1
11	05.286.02	NUT M10 PLATED*	1
11	05.292.15	BOLT M10 X 120MM PLATED	1
11*	42815.01	BRACKET - ACCUMULATOR	1
12	42815.02	SPACER	1
13	09.852.01	DECAL - ARM FLOAT	1

*MAIN PART IN GROUP, RELATED PARTS HAVE SAME REFERENCE NUMBER

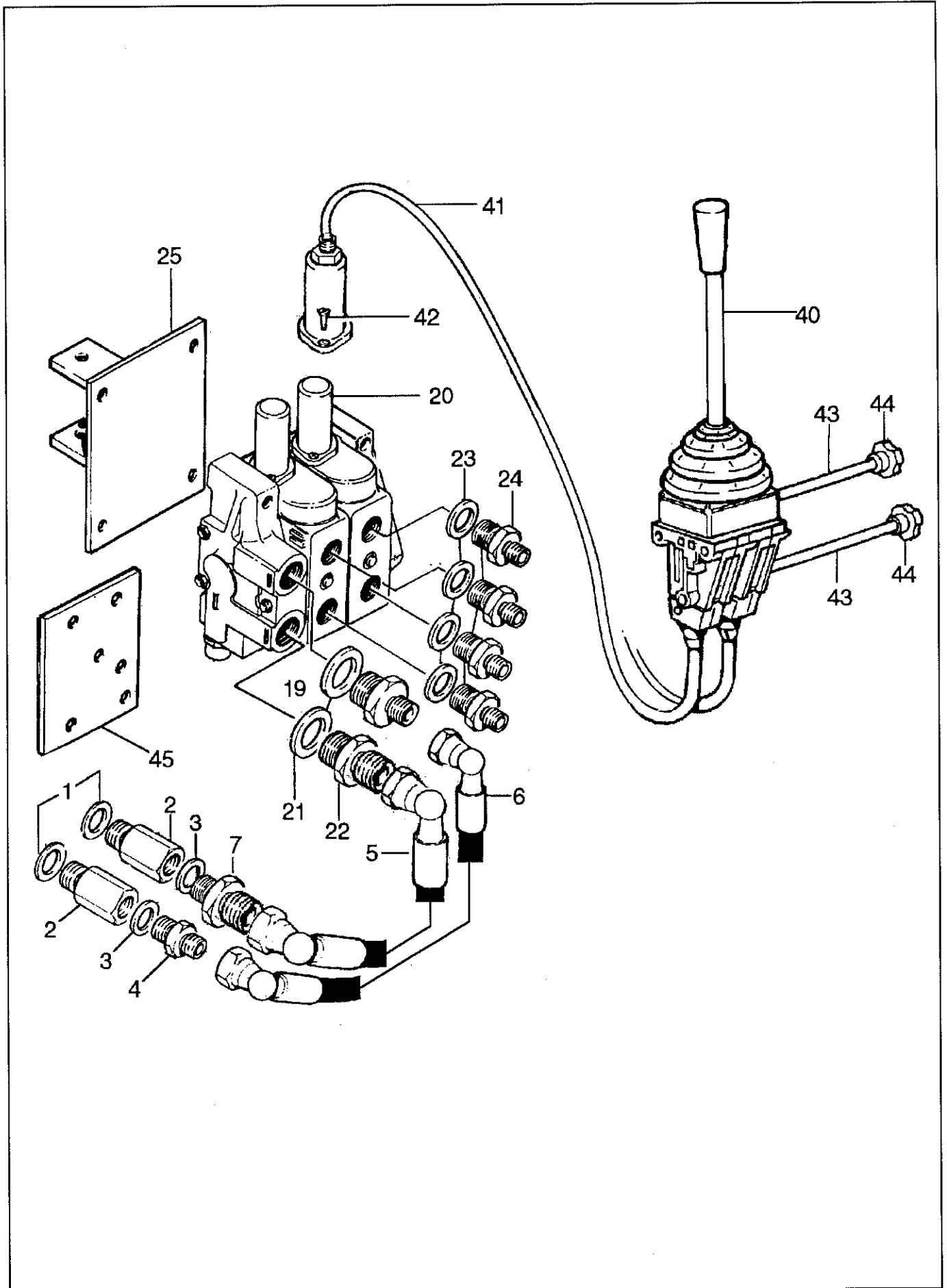

REF	PART NO	DESCRIPTION	QTY
72.470.02 CONTROL VALVE TRAC HYD KIT			
01	05.290.05	BONDED SEAL 1/2"BSP	2
*02	05.225.01	ADAPTOR-RDCG.1/2"BSP X 3/8"BSP	2
02	05.300.03	PLUG-PLASTIC 1/2"BSP FEMALE	2
03	05.290.04	BONDED SEAL 3/8"BSP	2
04	08.955.12	ADAPTOR 1/2"BSP X 3/4"-16 JIC	1
05	08.958.28	HOSE 3/8"BORE X 2000 JIC 90 X ST	1
06	08.955.14	ADAPTOR 1/2"BSPX1.1/16"-12 JIC	1
07	08.959.31	HOSE 3/4"BORE X 2000 JIC 90 X ST	1
72.471.03 CONTROL VALVE ASSY			
*20	41335.04	VALVE ASSY - 2 SPOOL	1
20	05.625.11	SKT CAPSCRW 1/4UNC X 5/8 PLATED	4
21	05.290.06	BONDED SEAL 3/4"BSP	2
22	08.955.17	ADAPTOR 3/4"BSP X 3/4"-16 JIC	1
23	05.290.05	BONDED SEAL 1/2"BSP	4
24	08.955.11	ADAPTOR 1/2"BSP X 9/16"-18 JIC	4
*25	09.244.01	BRACKET - VALVE	1
25	05.282.02	SPRING WASHER 10MM PLATED	4
25	05.286.02	NUT M10 PLATED	4
25	05.291.17	BOLT M10 X 60MM PLATED	3
25	05.292.13	BOLT M10 X 100MM PLATED	1
26	08.955.19	ADAPTOR 3/4"BSPX1.1/16"-12 JIC	1
72.472.01 REMOTE CONTROL ASSEMBLY			
40	08.206.01	REMOTE CONTROL DUAL-AXIS	1
41	30.207.29	3M CONTROL CABLE(KONTAK VALVE)	2
42	05.836.26	PAN HD SCREW 1/4"UNC X 3/4"PLTD	4
43	3012263-01	BRIGHT ROUND 8MM X 110	2
44	30.204.40	KNOB QUICK RELEASE (98M8ALLOY)	2
*45	09.302.01	PLATE - MOUNTING	1
45	05.264.01	SETSCREW M8 X 20MM PLATED	2
45	05.281.01	FLAT WASHER 8MM PLATED	2
45	05.948.07	WING NUT M8 - PLATED	2

*MAIN PART IN GROUP, RELATED PARTS HAVE SAME REFERENCE NUMBER

Parts Manual for
WGC No: 91.243.02
BX324 RH DRV XT RM

Print date: 20/06/2013

Applicable to Works Order No:

For Serial No:

IMPORTANT

NOTE HERE THE SERIAL NUMBER OF YOUR MACHINE AND ALWAYS QUOTE IT IN ANY COMMUNICATION WITH US OR YOUR DEALER. THIS IS PARTICULARLY IMPORTANT WHEN ORDERING SPARES. REMEMBER TO INCLUDE ALL NUMBERS AND LETTERS

MACHINE SERIAL NUMBERS _____

THE INFORMATION GIVEN THROUGHOUT THIS MANUAL IS CORRECT AT THE TIME OF PUBLICATION. HOWEVER, IN THE COURSE OF CONSTANT DEVELOPMENT OF BOMFORD TURNER MACHINES, CHANGES IN SPECIFICATION ARE INEVITABLE. SHOULD YOU FIND THE INFORMATION GIVEN IN THIS BOOK TO BE AT VARIANCE WITH THE MACHINE IN YOUR POSSESSION, YOU ARE ADVISED TO CONTACT THE BOMFORD TURNER SERVICE DEPARTMENT WHERE UP-TO-DATE INFORMATION WILL BE PROVIDED.

THE MANUAL CAN CONTAIN STANDARD AND OPTIONAL FEATURES AND IS NOT TO BE USED AS A MACHINE SPECIFICATION.

THE MACHINE HAS BEEN TESTED AND IS CONSIDERED SAFE IF CAREFULLY USED. ENSURE YOUR OPERATOR IS PROPERLY TRAINED IN ITS USE AND MAINTENANCE.

IMPORTANT

NOTEZ ICI LES NUMEROS DE SERIE DE VOTRE MACHINE ET MENTIONNEZ LES DANS TOUTE COMMUNICATION AVEC NOS SERVICES OU VOTRE REVENDEUR. CECI EST IMPORTANT POUR LA COMMANDE DE PIECES DETACHEES. PENSEZ A NOTER TOUS LES NUMEROS ET TOUTES LES LETTERS.

NUMEROS DE SERIE DE LA MACHINE _____

LES INFORMATIONS DONNEES DANS CE MANUEL SONT CORRECTES CEPENDANT, DU FAIT DE DEVELOPPEMENT CONSTANT DES MACHINES BOMFORD TURNER.

CHANGEMENTS DANS LES CARACTERISTIQUES SONT INEVITABLES.

SI VOUS TROUVEZ QUE LES INFORMATIONS DONNEES NE CORRESPONDENT PAS A VOTRE MACHINE VEUILLEZ CONTACTER LE SERVICE DES REPARATIONS OU DES INFORMATIONS PLUS RECENTES VOUS SERONT DONNEES.

CE MANUEL PEUT MONTRER DES CARACTERISTIQUES OPTIONNELLES ET NE PEUT PAS ETRE CONSIDERE COMME SPECIFICATION DE LA MACHINE.

CETTE MACHINE A ETE TESTEE, ET ELLE EST CONSIDEREE COMME FIABLE A CONDITION D'UNE BONNE UTILISATION. ASSUREZ-VOUS QUE VOTRE OPERATEUR EST QUALIFIE EN CE QUI CONCERNE L'UTILISATION DE LA MACHINE AINSI QUE SON ENTRETIEN.

WICHTIG

TRAGEN SIE HIER DIE SERIENNUMMERN IHRER MASCHINE EIN UND GEBEN SIE DIESE IMMER AN, WENN SIE SICH AN UNS ODER IHREN HÄNDLER WENDEN. DAS IST BESONDERS BEI ERSATZTEILBESTELLUNGEN WICHTIG. VERGESSEN SIE NICHT, ALLE ZAHLEN UND BUCHSTABEN ZU NOTIEREN.

SERIENNUMMERN DER MASCHINE _____

DIE ANGABEN INDIESEM HANDBUCH SIND BEI VERÖFFENTLICHUNG KORREKT. AUFGRUND DER KONSTANTEN WEITERENTWICKLUNG VON BOMFORD TURNER MASCHINEN SIND JEDOCHÄNDERUGDEN IN DER SPEZIFIKATION UNVERMEIDLICH. WENN DIE INFORMATION IN DIESEM HANDBUCH NICHT MIT IHRER MASCHINE ÜBEREINSTIMMEN, NEHMEN SIE BITTE KONTAKT MIT DER BOMFORD TURNER KUNDENDIENSTABTEILUNG AUF, DIE IHNEN GERNE DIE AKTUELLEN INFORMATION ZUKOMMEN LÄSST.

DAS HANDBUCH KANN SOWOHL BESCHREIBUNGEN FÜR DIE STANDARD AUSFÜHRUNG ALS AUCH FÜR ZUBEHÖR ENTHALTEN UND IST NICHT ALS MASCHINENSPEZIFIKATION ZU VERWENDET.

DIE MASCHINE IST GETESTET UND BEI SACHGEMÄSSEM BETRIEB ALS SICHER BEFUNDEN WORDEN. SORGEN SIE DAFÜR, DASS IHR BEDIENPERSONAL IN ANWENDUNG UND WARTUNG RICHTIG GESCHULT WIRD.

CONTENTS

Page No	Schedule No	Schedule Description
1	72.478.01	PTO SHAFT ASSEMBLY 4
3	72.487.01	B313S HOSE KIT 4212
5	74.984.01	RAMS/HOSES
7	74.985.02	ROLLER ASSY.
9	74.986.02	COWL ASSY
11	74.992.02	LINKS
13	74.993.01	GEARBOX ASSEMBLY
15	74.994.01	BEARING ASSEMBLY
17	76.019.02	MAINFRAME ASSY
19	76.020.01	ARM
21	76.022.04	SHAFT ASSY
23	76.023.02	DECALS
25	76.027.01	DRIVE BRKT PULLEYS
27	76.039.02	PACK

* optional component

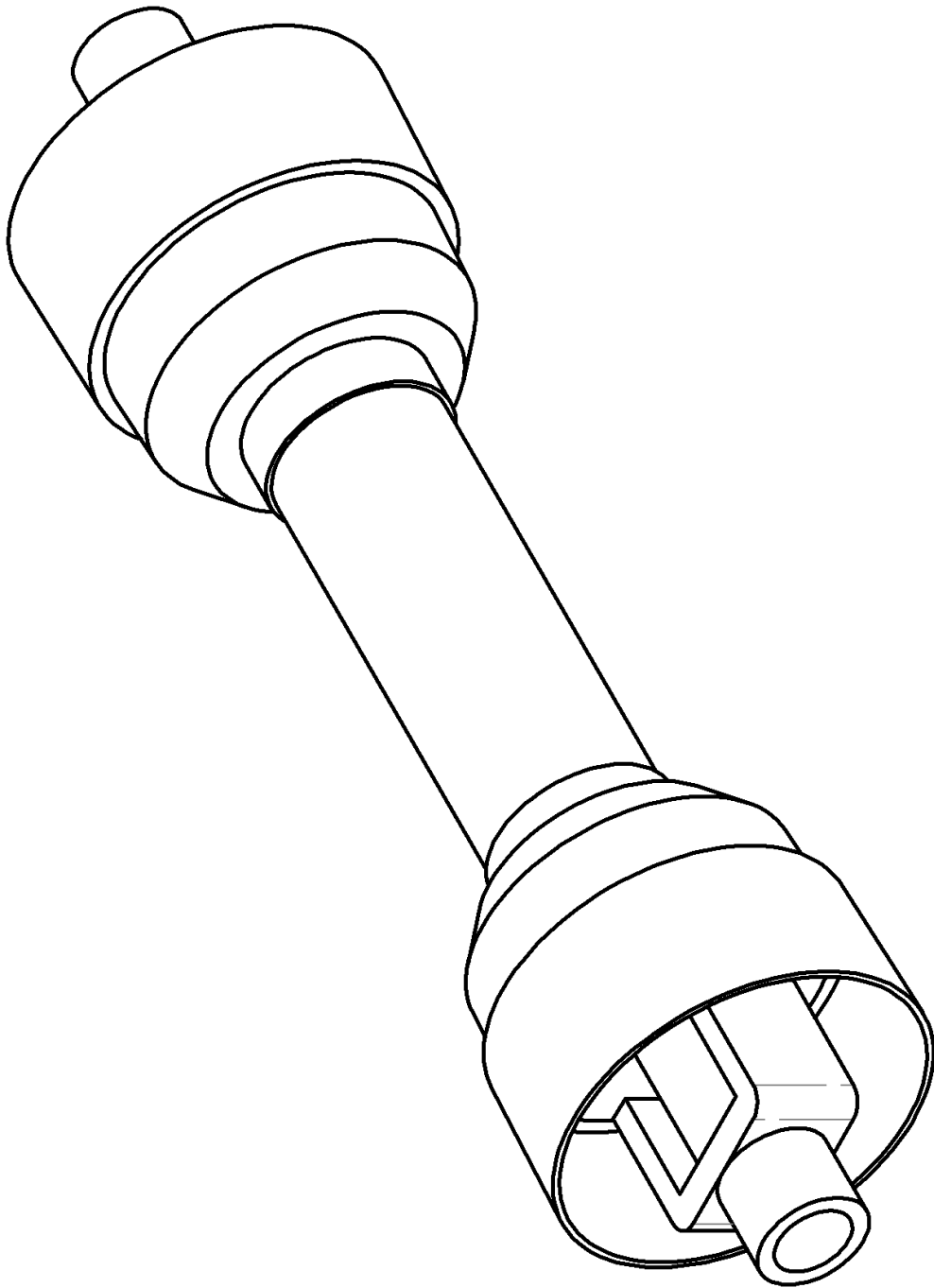

Ref	Part No	Description	Qty
0	41624.31	CROSS JOURNAL SET	0
0	41624.34	GUARD	0
7	41624.06	PTO SHAFT	1

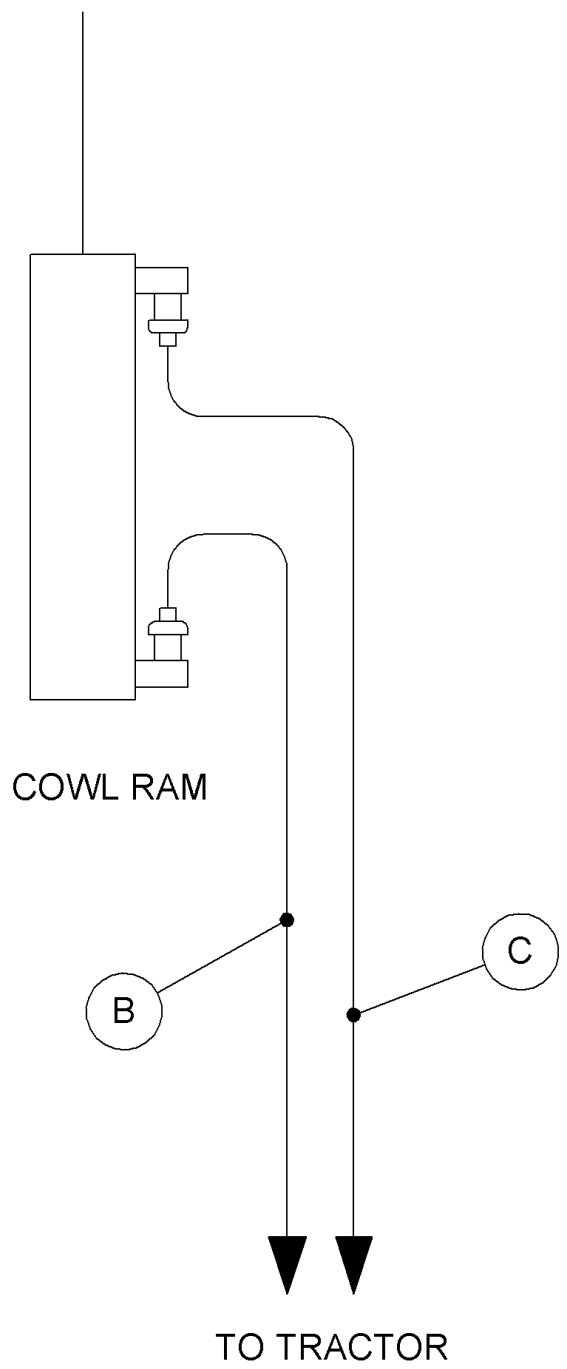
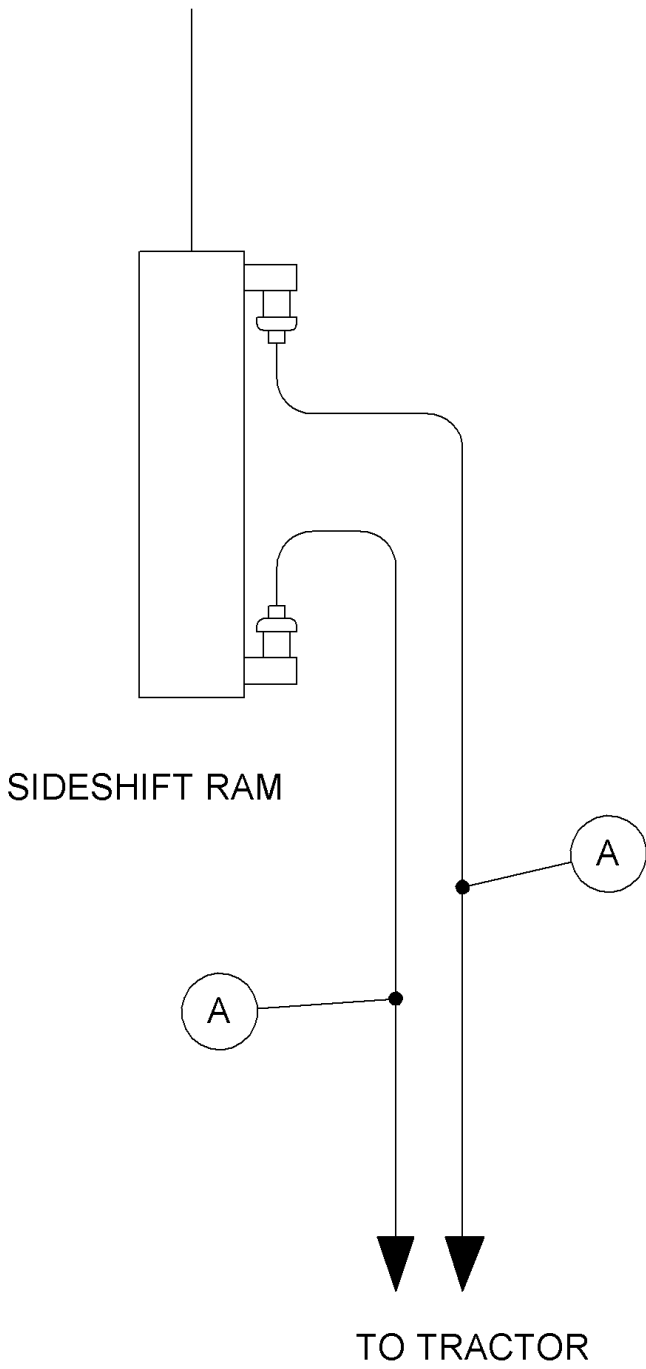

Ref	Part No	Description	Qty
0	09.295.01	B313S HYD CIRCUIT	0
0	09.296.01	B313S HOSE SERV KIT	1

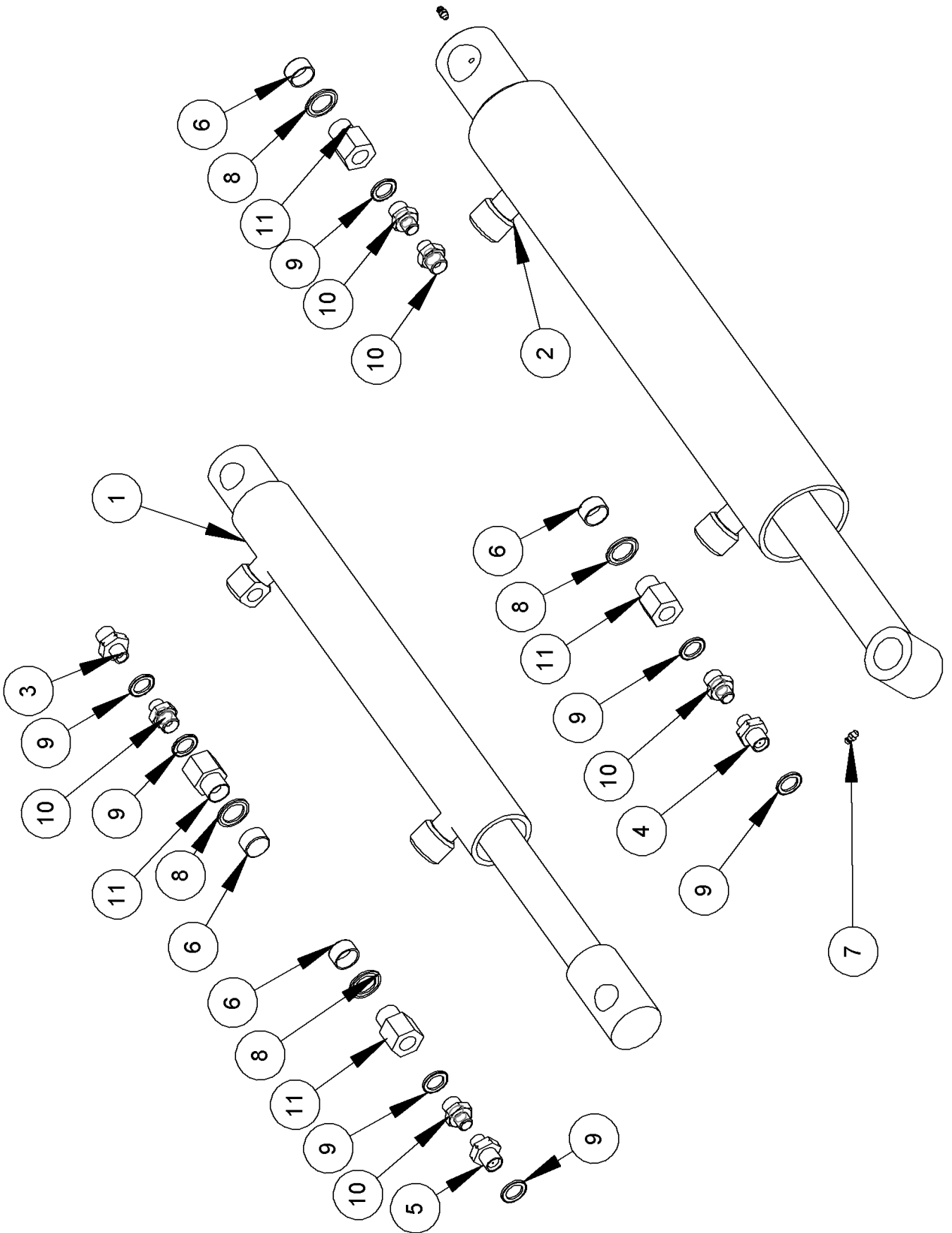

Ref	Part No	Description	Qty
0	01.099.01	ADAPTOR	5
0	05.225.01	ADAPTER	4
0	05.290.04	BONDED SEAL 3/8" BSP	8
0	05.290.05	SEAL	4
0	05.300.03	PLUG	4
0	05.953.01	GREASER	2
0	10.002.34	HOSE	0
0	10.002.44	HOSE	0
0	41.042.01	SEAL KIT	0
0	46518.16	RESTRICTOR	1
0	48200.01	RAM ASSY	1
0	48203.04	RAM ASSY	1
0	48203.25	SEAL KIT	0
7	46518.12	RESTRICTOR	1
8	46518.08	RESTRICTOR	1
14	10.002.32	HOSE	0
14	10.002.39	HOSE	0

**No Picture
Available**

Ref	Part No	Description	Qty
30	05.282.03	WASHER	8
30	05.286.03	NUT	6
30	05.839.34	BOLT	4
30	05.839.35	BOLT	2
30	42144.01	BRACKET	1
31	42144.02	BRACKET	1
32	05.959.05	CIRCLIP	4
33	42954.01	BEARING	2
34	04.164.04	SEAL	2
35	05.953.01	GREASER	4
35	41851.01	CAP	2
36	05.234.01	WASHER	2
36	05.625.10	CAPSCREW	2
36	42955.08	ROLLER	1

74.986.02 A - COWL ASSY

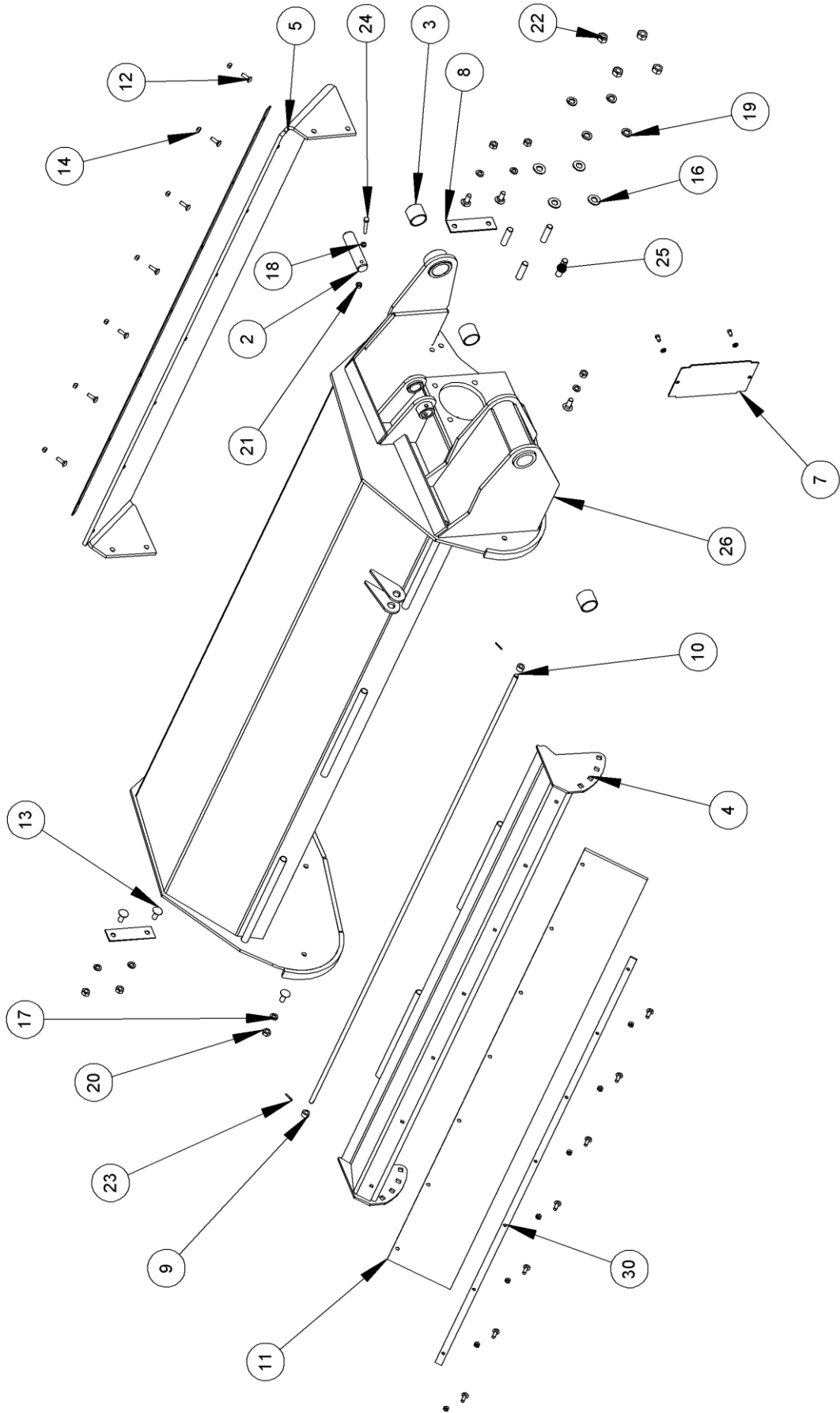

Ref	Part No	Description	Qty
2	03.654.54	PIN	1
3	08.297.02	BUSH	3
4	05.286.04	NUT	4
4	42125.01	HOOD	1
5	42127.01	FLAP	1
7	41.070.01	PLATE	1
8	41418.01	PLATE	2
9	41436.02	SPACER	2
10	42129.04	PIN	1
11	42126.01	FLAP	1
12	9293054	BOLT	14
13	05.839.26	BOLT	6
14	05.287.01	SELF LOCKING NUT M8	14
15	30.068.95	SETSCREW	2
16	05.281.04	WASHER	4
17	05.282.03	WASHER	6
18	05.282.01	SP.WASHER	3
19	05.282.04	WASHER	4
20	05.286.03	NUT	6
21	05.286.01	NUT	1
23	05.201.17	PIN	2
24	05.291.06	BOLT	1
25	03.886.01	STUD	4
26	42128.03	COWL	1
30	42128.43	PLATE	2

74.992.02 A - LINKS

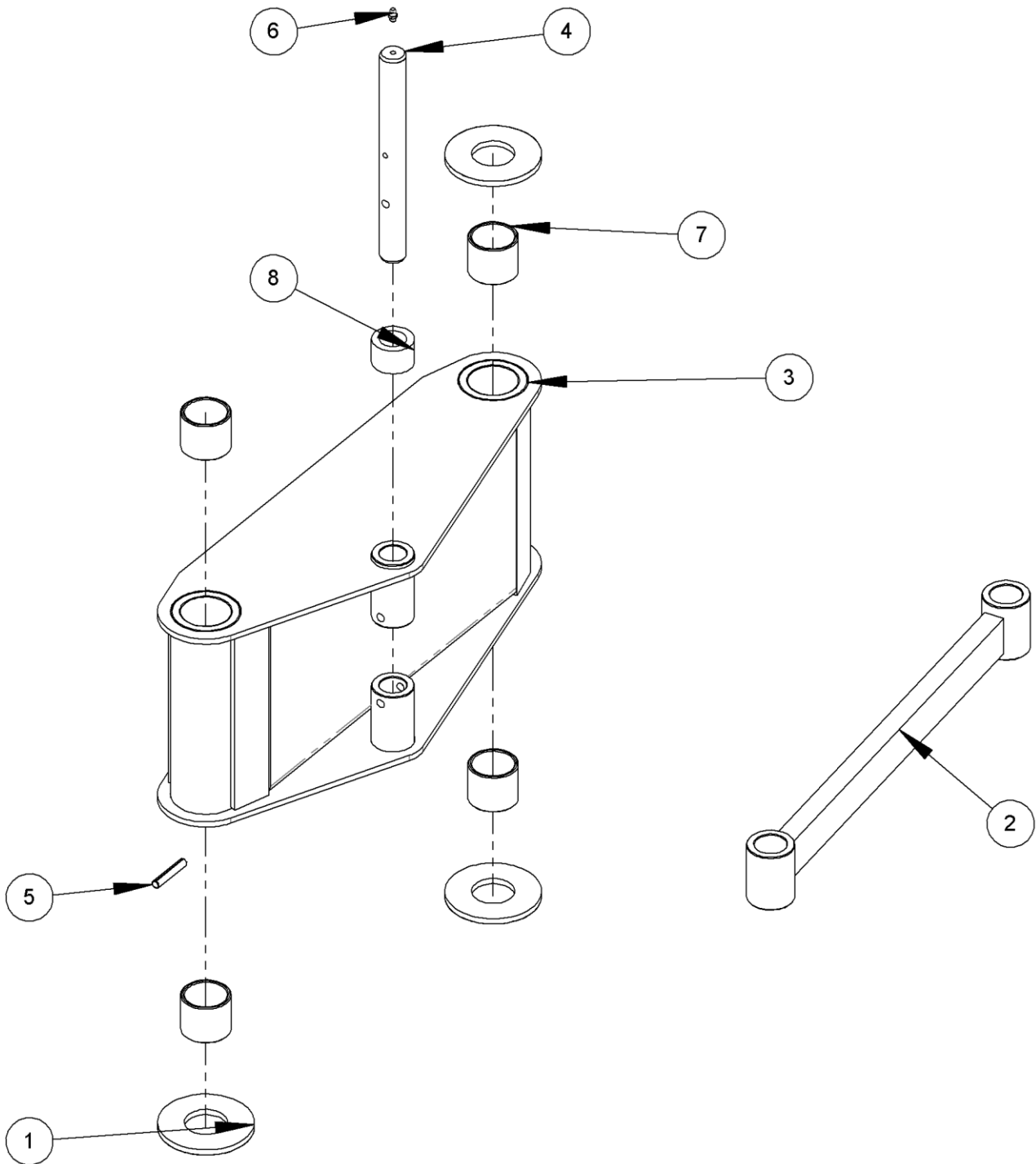

Ref	Part No	Description	Qty
1	09.232.01	WASHER	3
2	09.237.01	GUARD	1
3	41.246.02	LINK	1
4	03.653.71	PIN	1
5	05.201.07	SPIROL PIN	1
6	05.953.01	GREASER	1
7	08.297.02	BUSH	4
8	09.235.02	SPACER	1

74.993.01 A - GEARBOX ASSEMBLY

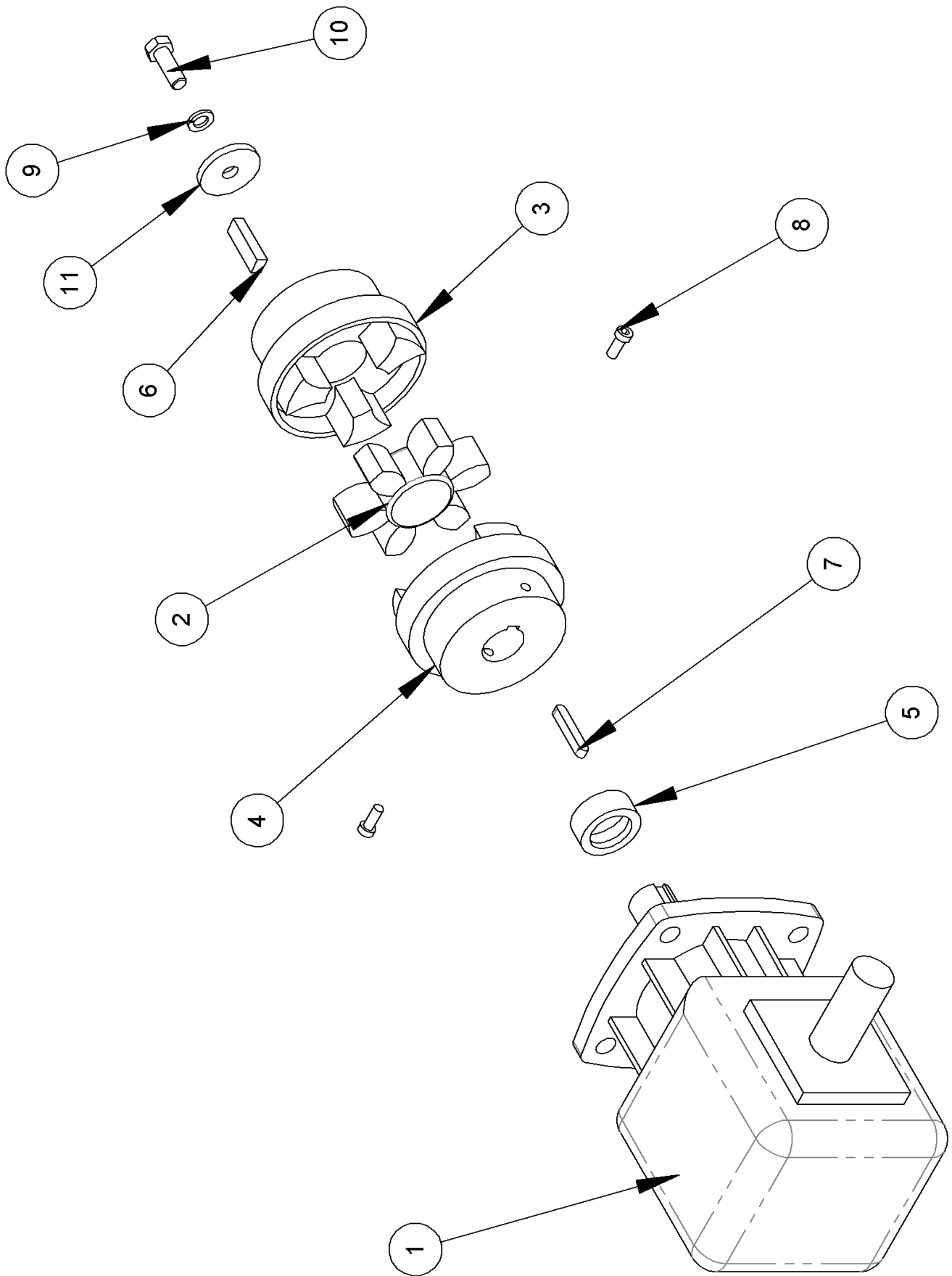

Ref	Part No	Description	Qty
1	09.250.04	GEARBOX	1
2	41.250.04	COUPLING	1
3	41.250.03	COUPLING	1
4	41.250.02	COUPLING	1
5	42613.02	SPACER	1
6	05.960.13	KEY	1
7	05.960.22	KEY	1
8	05.388.01	SCREW	2
9	05.282.03	WASHER	1
10	05.264.24	SETSCREW	1
11	02.824.01	WASHER	1

74.994.01 A - BEARING ASSEMBLY

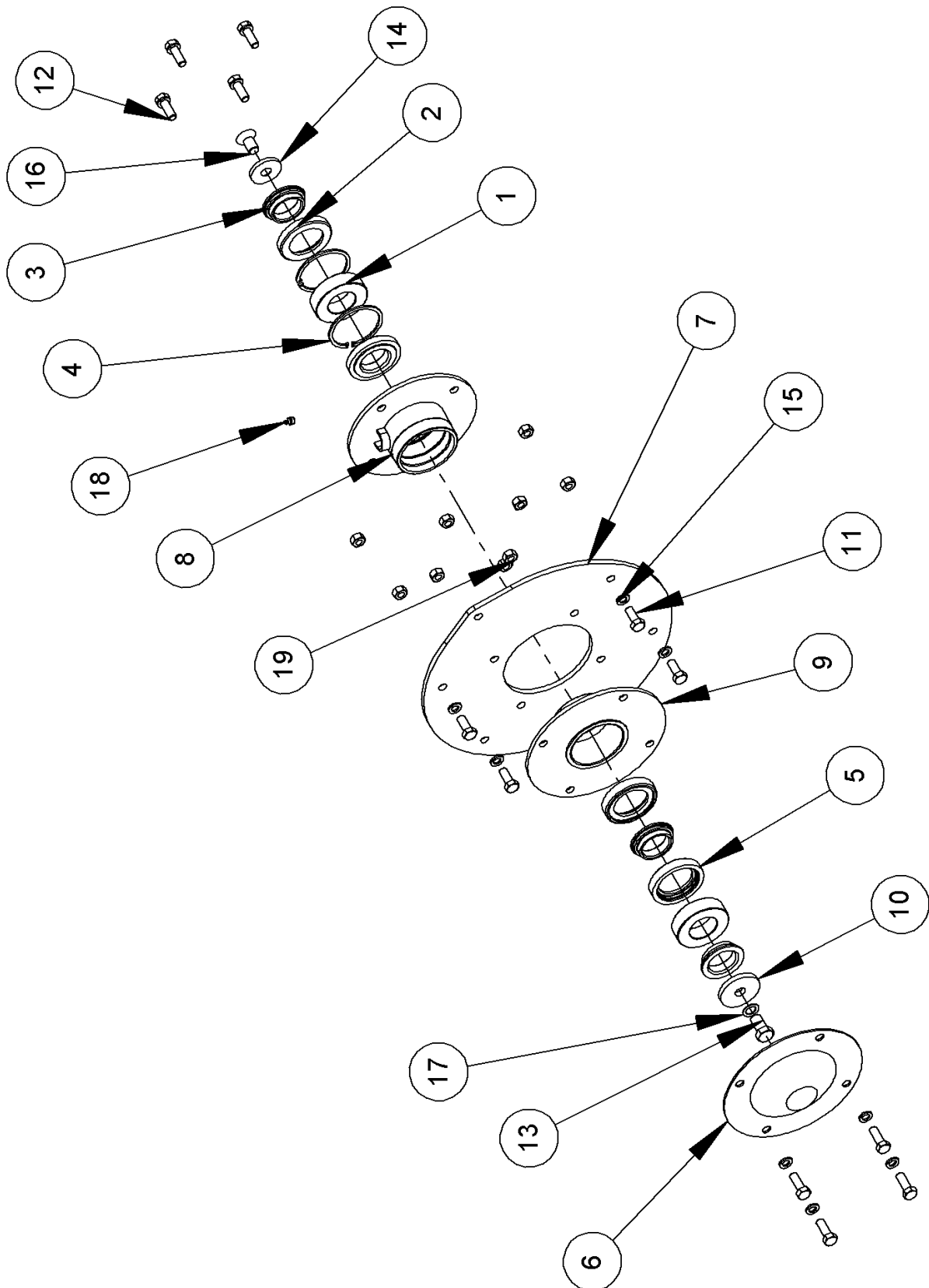

Ref	Part No	Description	Qty
0	43242.02	ASSY INST	0
1	04.163.04	BEARING	2
2	06.909.01	SPACER	2
3	06.910.01	SEAL	4
4	05.959.07	CIRCLIP	2
5	43272.01	SPACER	2
6	00.876.02	COVER	1
7	41.238.01	PLATE	1
8	41.240.01	HOUSING	1
9	04.268.02	HOUSING	1
10	04.252.01	WASHER	1
11	05.264.23	SETSCREW	5
12	05.264.24	SETSCREW	8
13	05.264.33	SETSCREW	1
14	41.257.01	WASHER	1
15	05.282.03	WASHER	13
16	05.345.08	SCREW	1
17	05.283.04	WASHER	1
18	05.953.03	GREASER	1
19	05.286.03	NUT	13

76.019.02 A - MAINFRAME ASSY

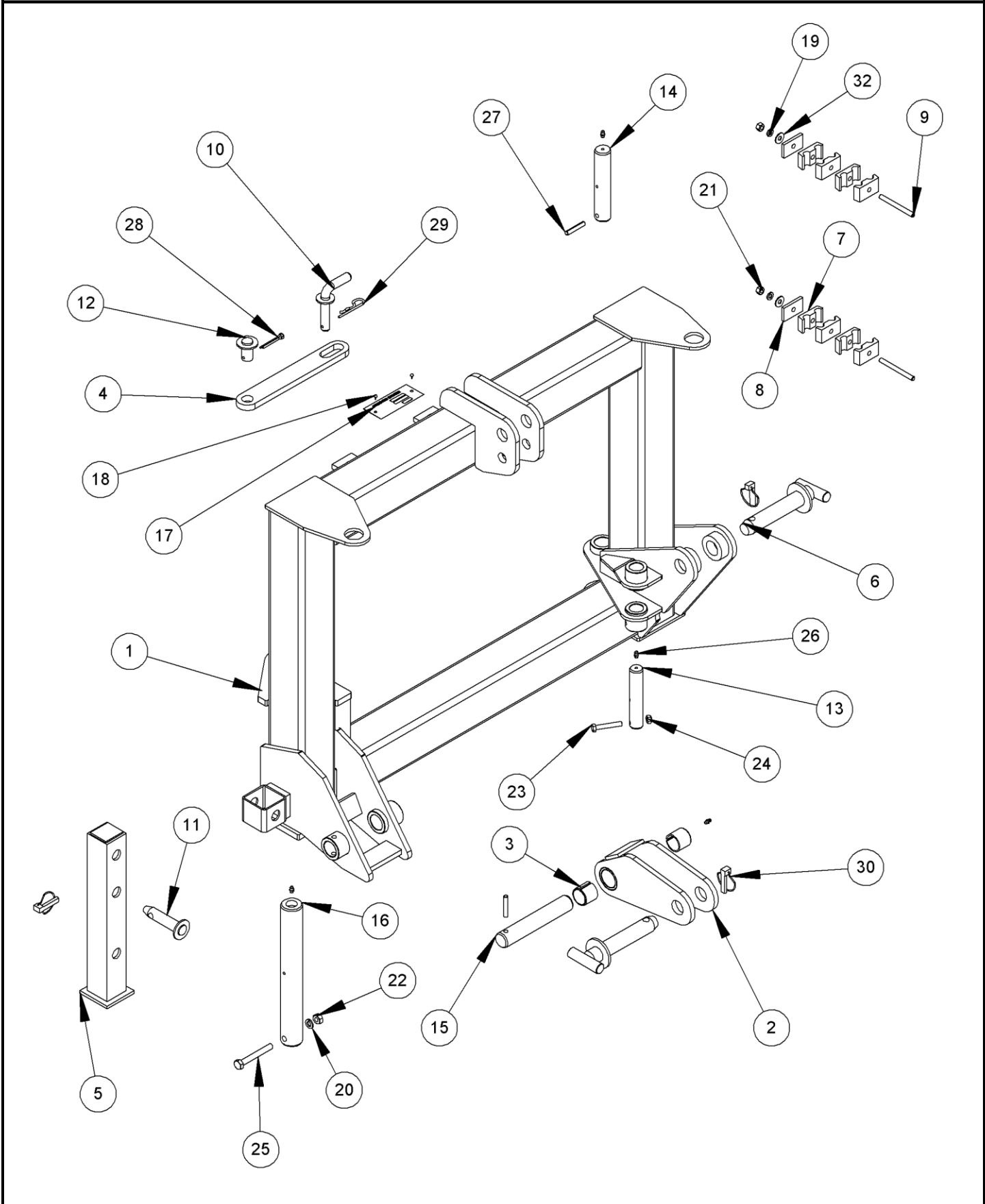

Ref	Part No	Description	Qty
1	42146.02	MAINFRAME RH	1
2	09.241.01	BREAKOUT	1
3	02.771.06	BUSH	2
4	42130.01	STRAP	1
5	41332.01	STAND	1
6	41.281.01	PIN	2
7	06.430.02	CLAMP, HOSE	8
8	05.281.01	WASHER	2
8	06.418.02	CLAMPING DEVICE	2
9	04.282.30	STUD	2
10	03.651.18	PIN	1
11	03.652.01	PIN	1
12	03.652.23	PIN	1
13	03.653.54	PIN	1
14	03.654.19	PIN	1
15	03.654.71	PIN	1
16	03.656.74	PIN	1
17	05.774.07	PLATE	1
18	05.227.01	SCREW	2
19	05.282.01	SP.WASHER	2
20	05.282.02	WASHER	1
21	05.286.01	NUT	2
22	05.286.02	NUT	1
23	05.291.05	BOLT	1
24	05.287.01	SELF LOCKING NUT M8	1
25	05.292.11	BOLT	1
27	05.201.07	SPIROL PIN	2
28	05.284.14	PIN	1
29	05.964.01	SPRING CLIP	1
30	00.372.01	LINCH PIN	3
31	05.953.03	GREASER	4

76.020.01 A - ARM

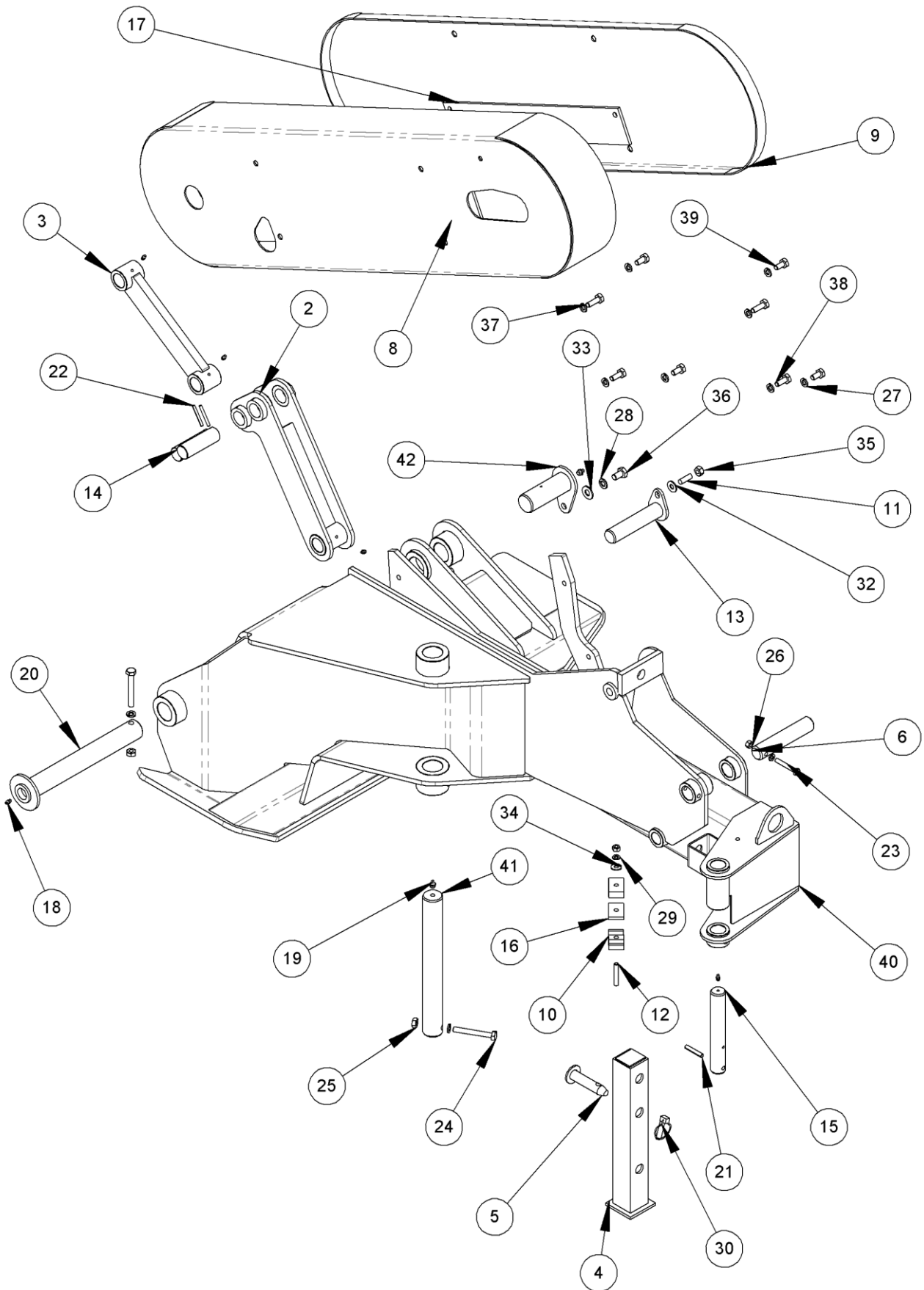

Ref	Part No	Description	Qty
2	41.241.01	LINK	1
3	41.060.01	LINK	1
4	41332.01	STAND	1
5	03.652.01	PIN	1
6	03.654.69	PIN	1
8	41764.02	GUARD	1
9	41775.01	GUARD	1
10	06.430.02	CLAMP, HOSE	2
11	04.175.01	STUD	1
12	04.282.32	STUD	1
13	02.837.01	PIN	1
14	03.654.53	PIN	2
15	03.654.70	PIN	1
16	06.418.02	CLAMPING DEVICE	1
17	43008.01	BRACKET	1
18	05.953.01	GREASER	5
19	05.953.03	GREASER	2
20	03.656.73	PIN	1
21	05.201.07	SPIROL PIN	1
22	05.201.11	SPIROL PIN	2
23	05.291.06	BOLT	1
24	05.292.11	BOLT	2
25	05.286.02	NUT	2
26	05.286.01	NUT	2
27	05.282.02	WASHER	10
28	05.282.03	WASHER	1
29	05.282.01	SP.WASHER	2
30	00.372.01	LINCH PIN	1
32	05.281.02	WASHER	1
33	05.281.03	WASHER	1
34	05.281.01	WASHER	1
35	05.968.02	NUT	1
36	05.264.21	SETSCREW	1
37	05.264.13	SETSCREW	2
38	05.264.12	M10 SETSCREW	2
39	05.264.11	SETSCREW	4
40	41.256.04	ARM RH	1
41	03.656.75	PIN	1
42	48667.01	PIN	1

**No Picture
Available**

Ref	Part No	Description	Qty
0	42151.03	SHAFT ASSY	1
30	42150.01	ROTOR SHAFT	0
31	05.775.10	BOLT	0
32	05.282.08	WASHER	0
33	05.968.06	NUT	0
37	09.517.01	SHACKLE	0
38	09.528.01	FLAIL	0

BOMFORD

BX324

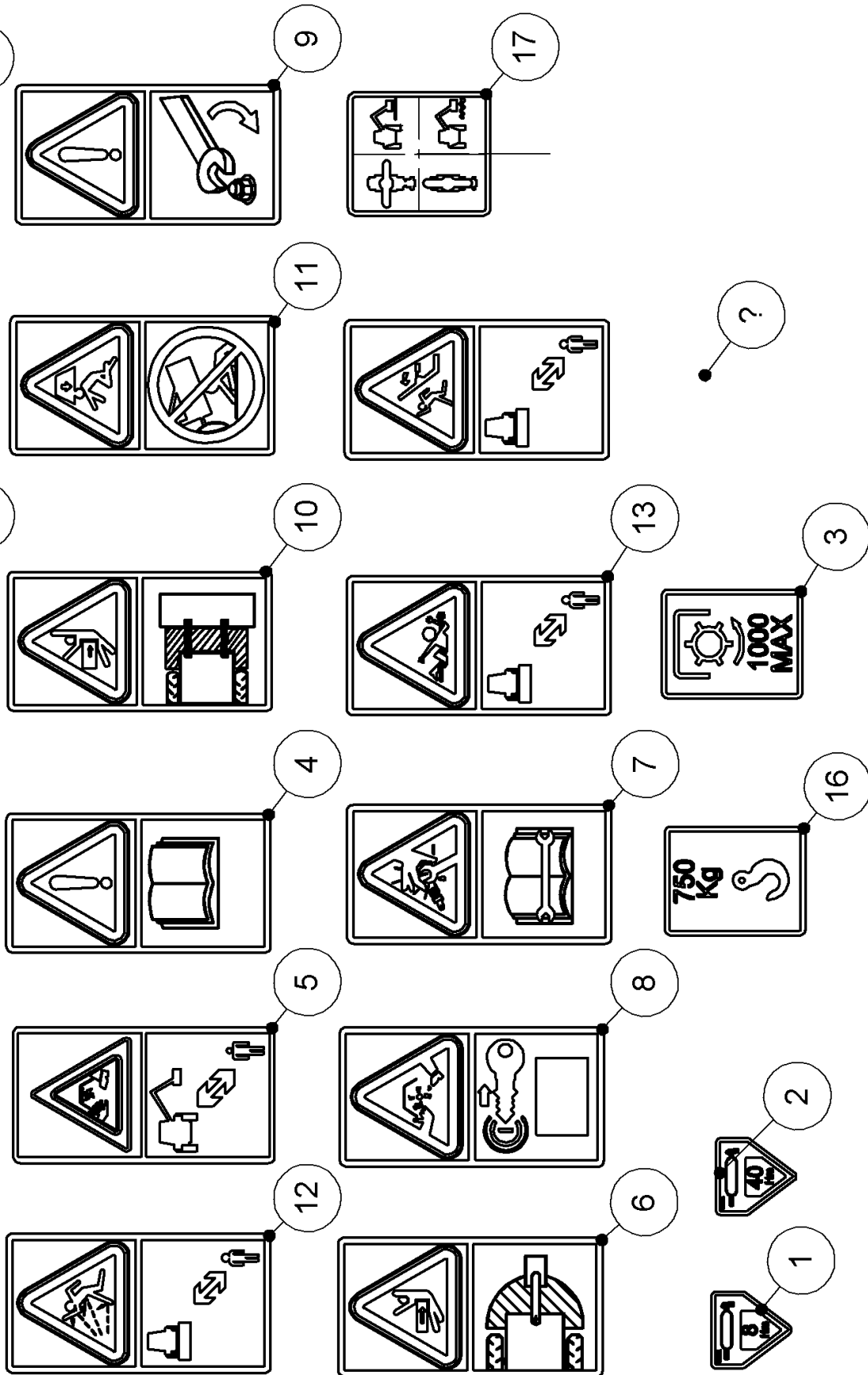

Ref	Part No	Description	Qty
0	09.821.21	DECAL	1
0	09.837.01	DECAL	2
1	09.980.31	DECAL	2
3	09.852.01	DECAL	0
4	09.843.04	DECAL	1
6	09.821.20	DECAL	1
7	09.821.18	DECAL	1
8	09.821.17	DECAL	1
9	09.821.16	DECAL	1
10	09.821.01	DECAL	1
11	09.821.10	DECAL	1
12	09.821.08	DECAL	1
13	09.821.07	DECAL	1
14	09.821.06	DECAL	1
15	09.821.05	DECAL	1
16	09.811.05	DECAL	1
17	09.810.02	DECAL	4
18	09.810.01	DECAL	9

76.027.01 A - DRIVE BRKT PULLEYS

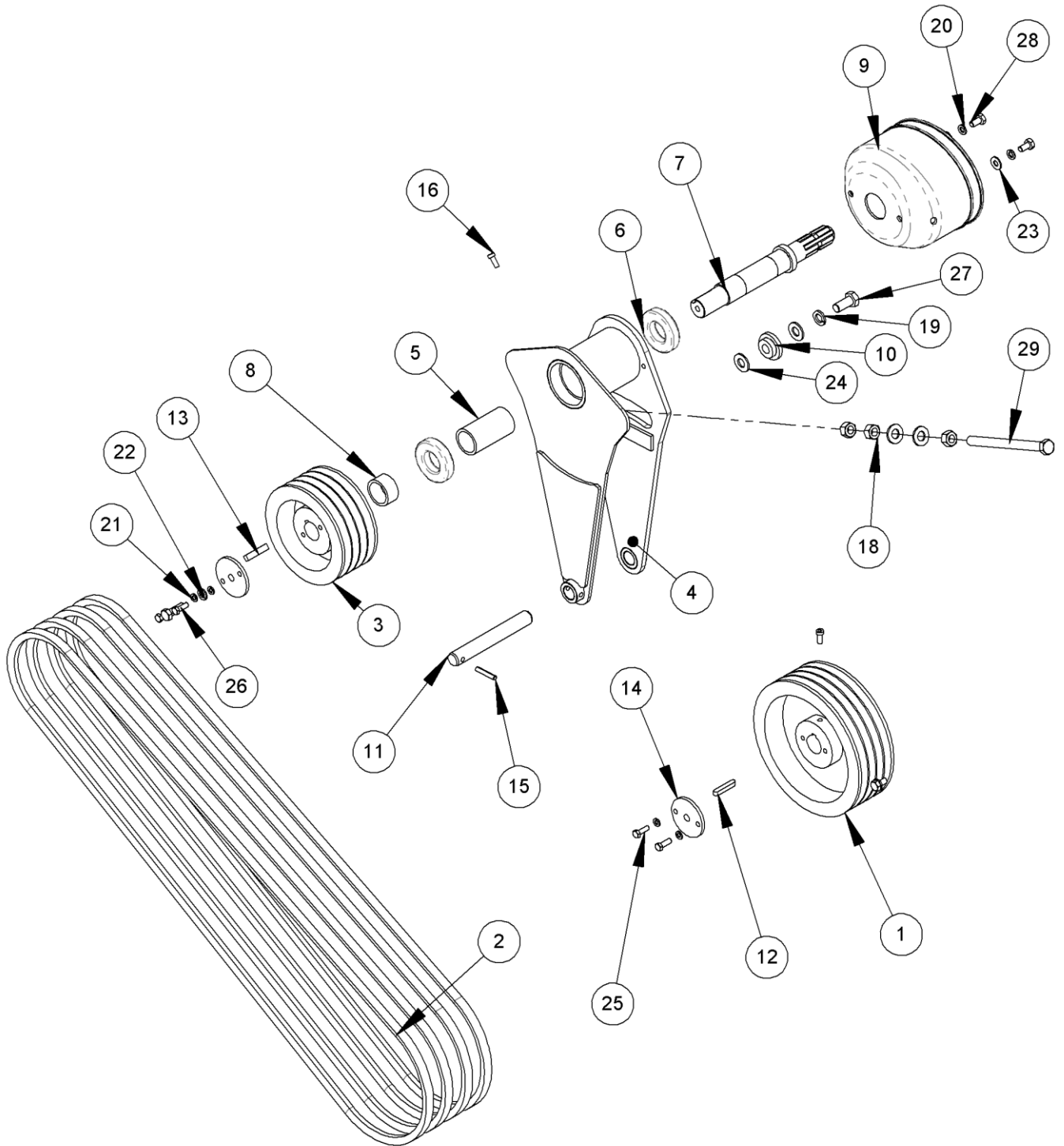

Ref	Part No	Description	Qty
1	41.245.01	PULLEY	1
2	05.299.51	BELT	4
3	41.244.01	PULLEY	1
4	41768.06	BRACKET	1
5	41.258.01	SPACER	1
6	03.007.06	BEARING	2
7	41730.01	SHAFT	1
8	09.264.01	SPACER	1
9	09.236.01	GUARD	1
10	09.263.01	COLLAR	1
11	03.653.63	25MM X 186 LONG	1
12	05.960.22	KEY	1
13	05.960.03	KEY	1
14	09.297.01	WASHER	2
15	05.201.07	SPIROL PIN	1
16	05.388.01	SCREW	2
18	05.286.04	NUT	3
19	05.282.04	WASHER	1
20	05.282.02	WASHER	2
21	05.282.01	SP.WASHER	4
22	05.282.03	WASHER	2
23	05.281.02	WASHER	2
24	05.281.04	WASHER	4
25	05.264.02	SETSCREW	4
26	05.264.24	SETSCREW	1
27	05.264.34	SETSCREW	1
28	05.264.11	SETSCREW	2
29	41769.01	SETSCREW	1

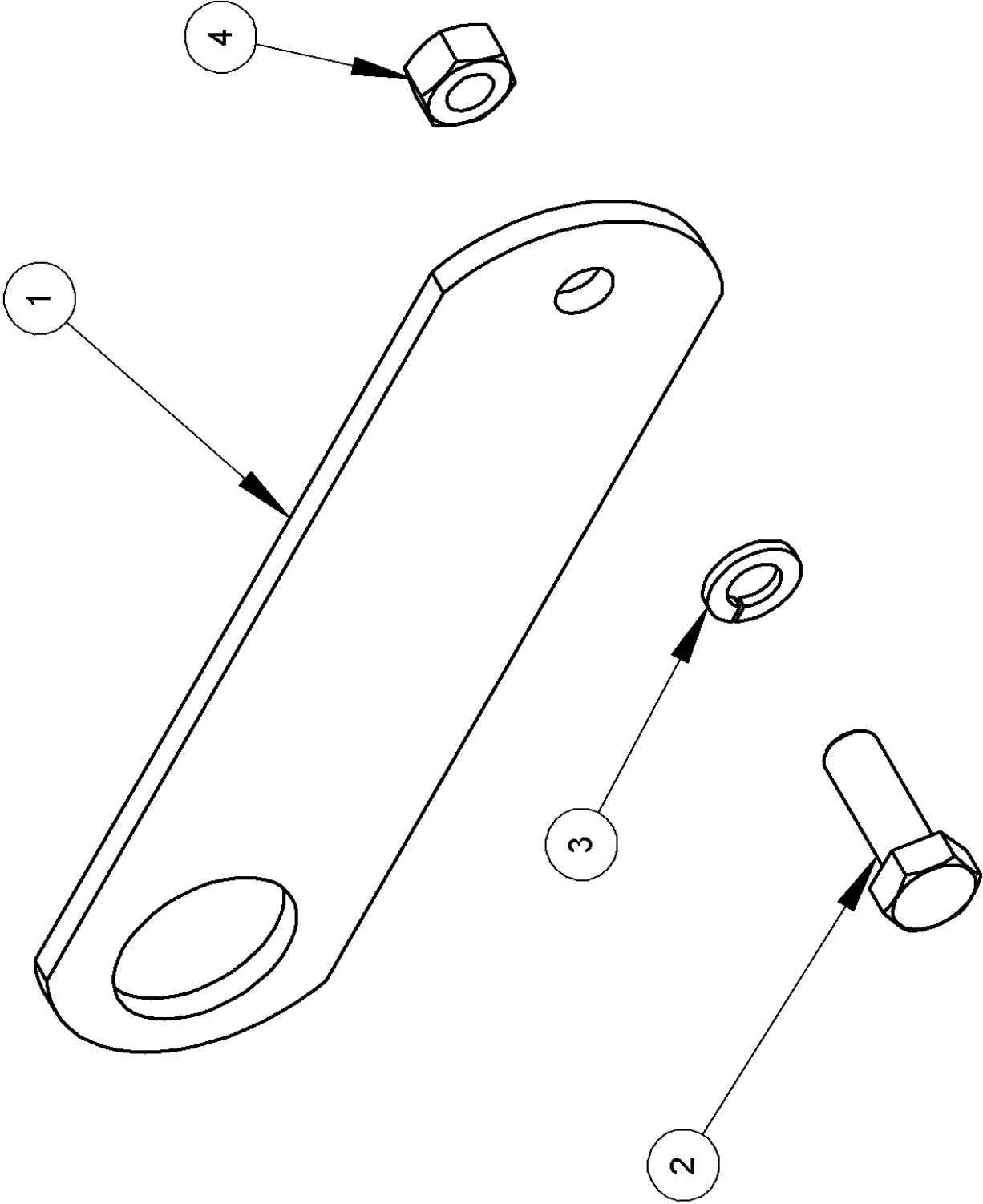

Ref	Part No	Description	Qty
1	41334.01	PLATE	1
2	05.264.24	SETSCREW	1
3	05.282.03	WASHER	1
4	05.286.03	NUT	1

WGC No: 91.243.02

BX324 RH DRV XT RM

For Serial No: