



BOOM ASSEMBLIES

Ford TS 100A CAB / WOC

Current as of 07/01/2010



PARTS LISTING WITH
MOUNTING AND OPERATING
INSTRUCTIONS

Tiger Corporation
3301 N. Louise Ave.
Sioux Falls, SD 57107
1-800-843-6849
1-605-336-7900
www.tiger-mowers.com

06020001

TO THE OWNER / OPERATOR / DEALER

All implements with moving parts are potentially hazardous. There is no substitute for a cautious, safe-minded operator who recognizes the potential hazards and follows reasonable safety practices. The manufacturer has designed this implement to be used with all its safety equipment properly attached to minimize the chance of accidents.

BEFORE YOU START!! Read the safety messages on the implement and shown in this manual. Observe the rules of safety and use common sense!

READ AND UNDERSTAND THIS MANUAL! Non-English speaking operators will need to GET THE MANUAL TRANSLATED as needed!



DANGER

FAILING TO FOLLOW SAFETY MESSAGES AND OPERATING INSTRUCTIONS CAN CAUSE SERIOUS BODILY INJURY OR EVEN DEATH TO OPERATOR AND OTHERS IN THE AREA.



1. Study and understand Operator's Manuals, Safety Decals, and Instructional Decals for tractor and implement to prevent misuse, abuse, and accidents. Practice before operating in a confined area or near passersby.

● Learn how to stop engine suddenly in an emergency. Be alert for passersby and especially children

2. Allow no children on or near folding mower or tractor. Allow no riders on tractor or implement. Falling off may cause serious injury or death from being run over by tractor or mower or contact with rotating blades.

3. Operate only with tractor having Roll-Over Protective Structure (ROPS) and with seat belt securely fastened to prevent injury and possible death from falling off or tractor overturn.

● Personal Protective Equipment such as Hard Hat, Safety Glasses, Safety Shoes, & Ear Plugs are recommended.

4. Block up or support raised machine and all lifted components securely before putting hands or feet under or working underneath any lifted component to prevent crushing injury or death from sudden dropping or inadvertent operation of controls. Make certain area is clear before lowering or folding

5. Before transporting, put Lift Lever in detent or full-lift position. Install Transport Safety Devices securely on folding mowers. Put Booms securely in Transport Rest.

● Folding and Boom Mowers have raised center of gravity. Slow down when turning and on hillsides.

6. Make certain that SMV sign, warning lights, and reflectors are clearly visible. Follow local traffic codes.

7. Never operate with Cutting Head or Folding Section raised if passersby, bystanders, or traffic are in the area to reduce possibility of injury or death from objects thrown by Blades under Guards or mower structure.

8. Before dismounting, secure implement in transport position or lower to ground.

● Put tractor in park or set brake, disengage PTO, stop engine, remove key, and wait until noise of rotation has ceased to prevent crushing by entanglement in rotating parts which could cause injury or death.

● Never mount or dismount a moving vehicle. Crushing from runover may cause serious injury or death.



02967827

Warranty Information: Read and understand the complete Warranty Statement found in this manual. Fill out the Warranty Registration form in full and return it within 90 days. Make certain the Serial Number of the machine is recorded on the Warranty Card, and form that you retain.

FORWARD

This manual contains information about many features of the Tiger mowing and roadside maintenance equipment. Some of these include: Safety precautions, Assembly instructions, Operations, Maintenance and Parts. This manual will also assist you in the proper break-in, daily care, and troubleshooting of your new mower.

We recommend that you read carefully the entire manual before operating the unit. Also, time spent in becoming fully acquainted with its performance features, adjustments, and maintenance schedules will be repaid in a long and satisfactory life of the equipment.

Troubleshooting - Please, before you call, help us to help you!

Please look at the equipment to observe what is happening, then:

- Classify the problem
 - Hydraulic, electrical or mechanical - Read the trouble shooting section
 - Tractor or Truck chassis - Contact vehicle dealer

- If unable to correct the problem yourself, contact your local Tiger Dealer after gathering:
 - Machine model _____
 - Serial number _____
 - Dealer name _____
 - Detailed information about the problem including results of troubleshooting

Attention Owner / Operator / Dealer It is your obligation to read, and understand, the warranty information section located at the back of this manual denoting that the purchaser understands the safety issues relating to this machine and has received and will read a copy of this manual.

If at any time, you have a service problem with your Tiger mower, Contact your local dealer for service and parts needed.

MANUFACTURED BY:

Tiger Corporation

3301 N. Louise Ave.

Sioux Falls, SD 57107

1-800-843-6849

1-605-336-7900

www.tiger-mowers.com

DISTRIBUTED BY:

1- _____ - _____ - _____

1- _____ - _____ - _____

TABLE OF CONTENTS

SAFETY _____	1-1
Safety Information_____	1-2
ASSEMBLY / MOUNTING SECTION _____	2-1
OPERATION SECTION _____	3-1
MAINTENANCE SECTION _____	4-1
PARTS SECTION _____	5-1
Parts Ordering Guide_____	5-2
Parts Table of Contents_____	5-3
Common Parts Section _____	6-1
WARRANTY INFORMATION _____	7-1



1012

This symbol means:

CAUTION – YOUR SAFETY IS AT RISK!

When you see this symbol, read and follow the associated instructions carefully or personal injury or damage may result.

Tiger is a registered trademark.



SAFETY

SAFETY SECTION

SAFETY

General Safety Instructions and Practices

A safe and careful operator is the best operator. Safety is of primary importance to the manufacturer and should be to the owner / operator. Most accidents can be avoided by being aware of your equipment, your surroundings, and observing certain precautions. The first section of this manual includes a list of Safety Messages that, if followed, will help protect the operator and bystanders from injury or death. Read and understand these Safety Messages before assembling, operating or servicing this mower. This equipment should only be operated by those persons who have read the Manual, who are responsible and trained, and who know how to do so safely and responsibly.



1000

The Safety Alert Symbol combined with a Signal Word, as seen below, is used throughout this manual and on decals which are attached to the equipment. The Safety Alert Symbol means: **“ATTENTION! BECOME ALERT! YOUR SAFETY IS INVOLVED!”** The symbol and signal word are intended to warn the owner / operator of impending hazards and the degree of possible injury when operating this equipment.

Practice all usual and customary safe working precautions and above all -- remember safety is up to YOU! Only YOU can prevent serious injury or death from unsafe practices.

DANGER!



Indicates an imminently hazardous situation that, if not avoided, WILL result in DEATH OR VERY SERIOUS INJURY.

WARNING!



Indicates an imminently hazardous situation that, if not avoided, COULD result in DEATH OR SERIOUS INJURY.

CAUTION!



Indicates an imminently hazardous situation that, if not avoided, MAY result in MINOR INJURY.

IMPORTANT!

Identifies special instructions or procedures that, if not strictly observed, could result in damage to, or destruction of the machine, attachments or the environment.

NOTE: *Identifies points of particular interest for more efficient or convenient operation or repair.* (SG-1)

READ, UNDERSTAND, and FOLLOW the following Safety Messages. Serious injury or death may occur unless care is taken to follow the warnings and instructions stated in the Safety Messages. Always use good common sense to avoid hazards. (SG-2)

SAFETY INSTRUCTIONS



SAFETY

PELIGRO!



Si no lee Ingles, pida ayuda a alguien que si lo lea para que le traduzca las medidas de seguridad. (SG-3)



¡ LEA EL INSTRUCTIVO!

DANGER!



Never operate the Tractor or Implement until you have read and completely understand this Manual, the Tractor Operator's Manual, and each of the Safety Messages found in the Manual or on the Tractor and Implement. Learn how to stop the tractor engine suddenly in an emergency. Never allow inexperienced or untrained personnel to operate the Tractor and Implement without supervision. Make sure the operator has fully read and understood the manuals prior to operation. (SG-4)



WARNING!



Always maintain the safety decals in good readable condition. If the decals are missing, damaged, or unreadable, obtain and install replacement decals immediately. (SG-5)

WARNING!



Make certain that the "Slow Moving Vehicle" (SMV) sign is installed in such a way as to be clearly visible and legible. When transporting the Equipment use the Tractor flashing warning lights and follow all local traffic regulations. (SG-6)



WARNING!



Operate this Equipment only with a Tractor equipped with an approved roll-over-protective system (ROPS). Always wear seat belts. Serious injury or even death could result from falling off the tractor--particularly during a turnover when the operator could be pinned under the ROPS. (SG-7)



WARNING!



Do not modify or alter this Implement. Do not permit anyone to modify or alter this Implement, any of its components or any Implement function. (SG-8)

DANGER!



BEFORE leaving the tractor seat, always engage the brake and/or set the tractor transmission in parking gear, disengage the PTO, stop the engine, remove the key, and wait for all moving parts to stop. Place the tractor shift lever into a low range or parking gear to prevent the tractor from rolling. Never dismount a Tractor that is moving or while the engine is running. Operate the Tractor controls from the tractor seat only. (SG-9)



SAFETY

DANGER!



Never allow children or other persons to ride on the Tractor or Implement. Falling off can result in serious injury or death.

(SG-10)



DANGER!



Never allow children to operate or ride on the Tractor or Implement.

(SG-11)



WARNING!



Do not mount the Tractor while the tractor is moving. Mount the Tractor only when the Tractor and all moving parts are completely stopped.

(SG-12)



DANGER!



Start tractor only when properly seated in the Tractor seat. Starting a tractor in gear can result in injury or death. Read the Tractor operators manual for proper starting instructions. (SG-13)



DANGER!



Never work under the Implement, the framework, or any lifted component unless the Implement is securely supported or blocked up to prevent sudden or inadvertent falling which could cause serious injury or even death. (SG-14)



DANGER!



Do not operate this Equipment with hydraulic oil leaking. Oil is expensive and its presence could present a hazard. Do not check for leaks with your hand! Use a piece of heavy paper or cardboard. High-pressure oil streams from breaks in the line could penetrate the skin and cause tissue damage including gangrene. If oil does penetrate the skin, have the injury treated immediately by a physician knowledgeable and skilled in this procedure. (SG-15)



SAFETY

WARNING!



The operator and all support personnel should wear hard hats, safety shoes, safety glasses, and proper hearing protection at all times for protection from injury including injury from items thrown by the equipment. (SG-16)

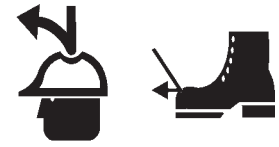

CAUTION!



PROLONGED EXPOSURE TO LOUD NOISE MAY CAUSE PERMANENT HEARING LOSS! Tractors with or without an Implement attached can often be noisy enough to cause permanent hearing loss. We recommend that you always wear hearing protection if the noise in the Operator's position exceeds 80db. Noise over 85db over an extended period of time will cause severe hearing loss. Noise over 90db adjacent to the Operator over an extended period of time will cause permanent or total hearing loss. *Note:* Hearing loss from loud noise [from tractors, chain saws, radios, and other such sources close to the ear] is cumulative over a lifetime without hope of natural recovery. (SG-17)



WARNING!



Transport only at safe speeds. Serious accidents and injuries can result from operating this equipment at unsafe speeds. Understand the Tractor and Implement and how it handles before transporting on streets and highways. Make sure the Tractor steering and brakes are in good condition and operate properly

Before transporting the Tractor and Implement, determine the safe transport speeds for you and the equipment. Make sure you abide by the following rules:

1. Test the tractor at a slow speed and increase the speed slowly. Apply the Brakes smoothly to determine the stopping characteristics of the Tractor and Implement. As you increase the speed of the Tractor the stopping distance increases. Determine the maximum safe transport speed for you and this Equipment.
2. Test the equipment at a slow speed in turns. Increase the speed through the turn only after you determine that it is safe to operate at a higher speed. Use extreme care and reduce your speed when turning sharply to prevent the tractor and implement from turning over. Determine the maximum safe turning speed for you and this equipment before operating on roads or uneven ground.
3. Only transport the Tractor and Implement at the speeds that you have determined are safe and which allow you to properly control the equipment.



Be aware of the operating conditions. Do not operate the Tractor with weak or faulty brakes. When operating down a hill or on wet or rain slick roads, the braking distance increases: use extreme care and reduce your speed. When operating in traffic always use the Tractor's flashing warning lights and reduce your speed. Be aware of traffic around you and watch out for the other guy. (SG-19)

SAFETY

WARNING!



Never attempt to lubricate, adjust, or remove material from the Implement while it is in motion or while tractor engine is running. Make sure the tractor engine is off before working on the Implement.

(SG-20)

WARNING!



Periodically inspect all moving parts for wear and replace when necessary with authorized service parts. Look for loose fasteners, worn or broken parts, and leaky or loose fittings. Make sure all pins are properly secured. Serious injury may occur from not maintaining this machine in good working order.

(SG-21)



WARNING!



Always read carefully and comply fully with the manufacturers instructions when handling oil, solvents, cleansers, and any other chemical agent.

(SG-22)



DANGER!



Never run the tractor engine in a closed building or without adequate ventilation. The exhaust fumes can be hazardous to your health.

(SG-23)

DANGER!



KEEP AWAY FROM ROTATING ELEMENTS to prevent entanglement and possible serious injury or death.

(SG-24)



DANGER!



Never allow children to play on or around Tractor or Implement. Children can slip or fall off the Equipment and be injured or killed. Children can cause the Implement to shift or fall crushing themselves or others.

(SG-25)

SAFETY

DANGER!



NEVER use drugs or alcohol immediately before or while operating the Tractor and Implement. Drugs and alcohol will affect an operator's alertness and coordination and therefore affect the operator's ability to operate the equipment safely. Before operating the Tractor or Implement, an operator on prescription or over-the-counter medication must consult a medical professional regarding any side effects of the medication that would hinder their ability to operate the Equipment safely. **NEVER** knowingly allow anyone to operate this equipment when their alertness or coordination is impaired. Serious injury or death to the operator or others could result if the operator is under the influence of drugs or alcohol. (SG-27)



DANGER!



Operate the Tractor and/or Implement controls only while properly seated in the Tractor seat with the seat belt securely fastened around you. Inadvertent movement of the Tractor or Implement may cause serious injury or death. (SG-29)

WARNING!



Mow only in conditions where you have clear visibility in daylight or with adequate artificial lighting. Never mow in darkness or foggy conditions where you cannot clearly see at least 100 yards in front and to the sides of the tractor and mower. Make sure that you can clearly see and identify passersby, steep slopes, ditches, drop-offs, overhead obstructions, power lines, debris and foreign objects. If you are unable to clearly see this type of items discontinue mowing. (SGM-1)

DANGER!



There are obvious and hidden potential hazards in the operation of this Mower. **REMEMBER!** This machine is often operated in heavy brush and in heavy weeds. The Blades of this Mower can throw objects if shields are not properly installed and maintained. Serious injury or even death may occur unless care is taken to insure the safety of the operator, bystanders, or passersby in the area. Do not operate this machine with anyone in the immediate area. Stop mowing if anyone is within 100 yards of mower. (SGM-2)



DANGER!



All Safety Shields, Guards and Safety devices including (but not limited to) - the Deflectors, Chain Guards, Steel Guards, Gearbox Shields, PTO integral shields, and Retractable Door Shields should be used and maintained in good working condition. All safety devices should be inspected carefully at least daily for missing or broken components. Missing, broken, or worn items must be replaced at once to reduce the possibility of injury or death from thrown objects, entanglement, or blade contact. (SGM-3)

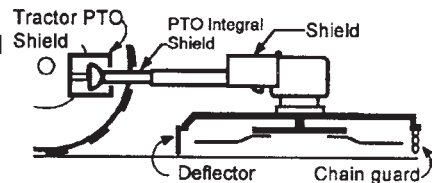

SAFETY

DANGER!



The rotating parts of this machine have been designed and tested for rugged use. However, the blades could fail upon impact with heavy, solid objects such as metal guard rails and concrete structures. Such impact could cause the broken objects to be thrown outward at very high velocities. To reduce the possibility of property damage, serious injury, or even death, never allow the cutting blades to contact such obstacles. (SGM-4)

WARNING!



Extreme care should be taken when operating near loose objects such as gravel, rocks, wire, and other debris. Inspect the area before mowing. Foreign objects should be removed from the site to prevent machine damage and/or bodily injury or even death. Any objects that cannot be removed must be clearly marked and carefully avoided by the operator. Stop mowing immediately if blades strike a foreign object. Repair all damage and make certain rotor or blade carrier is balanced before resuming mowing. (SGM-5)



WARNING!



Many varied objects, such as wire, cable, rope, or chains, can become entangled in the operating parts of the mower head. These items could then swing outside the housing at greater velocities than the blades. Such a situation is extremely hazardous and could result in serious injury or even death. Inspect the cutting area for such objects before mowing. Remove any like object from the site. Never allow the cutting blades to contact such items. (SGM-6)

WARNING!



Mow at the speed that you can safely operate and control the tractor and mower. Safe mowing speed depends on terrain condition and grass type, density, and height of cut. Normal ground speed range is from 0 to 5 mph. Use slow mowing speeds when operating on or near steep slopes, ditches, drop-offs, overhead obstructions, power lines, or when debris and foreign objects are to be avoided. (SGM-7)

WARNING!



Avoid mowing in reverse direction when possible. Check to make sure there are no persons behind the mower and use extreme care when mowing in reverse. Mow only at a slow ground speed where you can safely operate and control the tractor and mower. Never mow an area that you have not inspected and removed debris or foreign material. (SGM-8)

WARNING!



Do not put hands or feet under mower decks. Blade Contact can result serious injury or even death. Stay away until all motion has stopped and the decks are securely blocked up. (SGM-9)



DANGER!



Replace bent or broken blade with new blades. NEVER ATTEMPT TO STRAIGHTEN OR WELD ON BLADES SINCE THIS WILL LIKELY CRACK OR OTHERWISE DAMAGE THE BLADE WITH SUBSEQUENT FAILURE AND POSSIBLE SERIOUS INJURY FROM THROWN BLADES. (SGM-10)

SAFETY

WARNING!



Do not mow with two machines in the same area except with Cab tractors with the windows closed. (SGM-11)

DANGER!



Rotary and Flail Mowers are capable under adverse conditions of throwing objects for great distances (100 yards or more) and causing serious injury or death. Follow safety messages carefully. **STOP MOWING IF PASSERSBY ARE WITHIN 100 YARDS UNLESS:**

- Front and Rear Deflectors are installed and in good, working condition;
- Mower Head is running close to and parallel to the ground without exposed Blades;
- Passersby are outside the existing thrown-object zone;
- All areas have been thoroughly inspected and all foreign material such as rocks, cans, glass, and general debris has been removed.



NOTE: Where there are grass and weeds high enough to hide debris that could be struck by the blades, the area should be: inspected and large debris removed, mowed at an intermediate height, inspected closely with any remaining debris being removed, and mowed again at desired final height. (SBM-1)



DANGER!



Use extreme caution when raising the Mower head. Stop the Blades from turning when the Mower Head is raised and passersby are within 100 yards. Raising the Mower head exposes the Cutting Blades which creates a potentially serious hazard and can cause serious injury by objects thrown from the Blades or by contact with the Blades. (SBM-2)

DANGER!



Be particularly careful in transport. The Mower has raised the center of gravity for the tractor and has increased the possibility of overturn. Turn curves or go up slopes only at low speed and using a gradual turning angle. Slow down on rough or uneven surfaces. (SBM-3)



WARNING!



Never Leave the mower unattended while the head is in the raised position. The mower could fall causing serious injury to anyone who might inadvertently be under the mower (SBM-4)



WARNING!



The rotating parts of this machine continue to rotate even after the Tractor has been turned off. The operator should remain in his seat for 60 seconds after the brake has been set, the PTO disengaged, the tractor turned off, and all evidence of rotation has ceased. (SBM-5)

“Wait a minute...Save a life!”

SAFETY



Relieve hydraulic pressure prior to doing any maintenance or repair work on the Implement. Place the Mower Head on the ground or securely supported on blocks or stands, disengage the PTO, and turn off the engine. Push and pull the control Levers or Joystick several times to relieve pressure prior to starting any maintenance or repair work. (SBM-6)

DANGER!



Always keep a careful lookout and use extreme care when working around overhead obstructions. Never allow the Mower head or boom within 10 feet of any power line. When working close to overhead power lines consult your electric company for a safe code of operation.

(SBM-7)

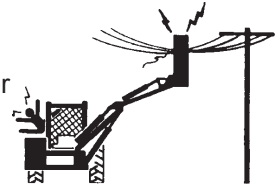

DANGER!



When transporting Boom Mower on a truck or trailer, the height or width may exceed legal limits when the boom is in the transport position. Contact with side or overhead structures or power lines can cause property damage or serious injury or death. If necessary lower boom to reduce height and/or remove mowing head to reduce width to the legal limits. (SBM-8)

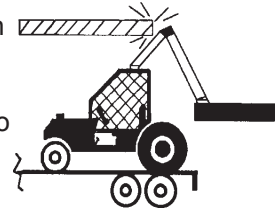

DANGER!



Never operate the Tractor and Mower Unit without an OPS (Operators Protective Structure) or Cab to prevent injury from objects thrown from ground or from overhead trimming. Stop mowing if workers or passersby are within 100 yards. (SBM-9)

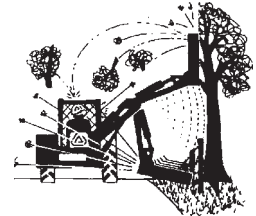

DANGER!



Each Rear Wheel must have a minimum of 1500 pound contact with the surface to prevent lateral instability and possible tip-over which could result in serious bodily injury or even death. Widen the wheel tread and add weights if needed. Refer to the mounting instructions or call Customer Service if you need assistance with Counterweight Procedure. (SBM-11)



DANGER!



Always disconnect the wire leads from the mower pump solenoid before performing service on the Tractor or Mower. Use caution when working on the Tractor or Mower. Tractor engine must be stopped before working on Mower or Tractor. The Mower Blades could inadvertently be turned on without warning and cause immediate dismemberment, injury or death. (SBM-12a)

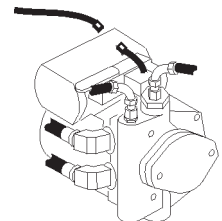

DANGER!



The flail cutter shaft is designed for standard rotation (same rotation as the tractor wheels during forward travel) **Never operate the cutter shaft in the reverse rotation.** Operating this mower in reverse rotation may cause objects to be thrown out the front of the mower head.

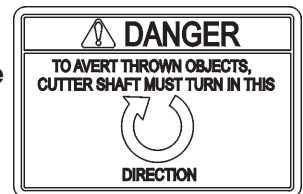

SAFETY

WARNING!



Engine Exhaust, some of its constituents, and certain components contain or emit chemicals known to the state of California to cause cancer and birth or other reproductive harm.

WARNING!



Battery posts, terminals and related accessories contain lead and lead compounds, chemicals known to the state of California to cause cancer and birth or other reproductive harm. **Wash hands after handling!**

Tiger mowers use balanced and matched system components for blade carriers, blades, cutter-shafts, knives, knife hangers, rollers, drive-train components and bearings. These parts are made and tested to Tiger specifications. Non-genuine “will fit” parts do not consistently meet these specifications. The use of “will fit” parts may reduce mower performance, void mower warranties and present a safety hazard. Use genuine Tiger mower parts for economy and safety.

SEE YOUR  DEALER

In addition to the design and configuration of this Implement, including Safety Signs and Safety Equipment, hazard control and accident prevention are dependent upon the awareness, concern, prudence, and proper training of personnel involved in the operation, transport, maintenance, and storage of the machine. Refer also to Safety Messages and operation instruction in each of the appropriate sections of the T ractor and Equipment Manuals. Pay close attention to the Safety Signs affixed to the T ractor and Equipment. (SG-18)

SAFETY

DANGER

FAILING TO FOLLOW SAFETY MESSAGES AND OPERATING INSTRUCTIONS CAN CAUSE SERIOUS BODILY INJURY OR EVEN DEATH TO OPERATOR AND OTHERS IN THE AREA.

<p>1. </p>	<p>2. NO RIDERS, NO CHILDREN OPERATORS</p>	<p>3. USE SAFETY SHOES, HARD HAT, SAFETY GLASSES, SEAT BELTS, & ROPS</p>	<p>4. BLOCK UP SECURELY BEFORE WORKING UNDER</p>
------------	---	---	---

1 Study and understand Operator's Manuals, Safety Signs, and Instructional Decals for tractor & flail mower to prevent misuse, abuse, & accidents. Practice before operating mower in a confined area or near passersby.

- Learn how to stop engine suddenly in an emergency. Be alert for passersby and especially children.

2 Allow no children on or near implement or tractor. Allow no riders on tractor or implement. Falling off can cause serious injury or death from being runover by tractor or mower or contact with Flail Mower Blades.

3 Operate only with tractor having Roll-Over Protective Structure (ROPS) and with seatbelt fastened securely and snugly to prevent injury and possible death from falling off or tractor overturn. Personal Protective Equipment such as Hard Hat, Safety Glasses, Safety Shoes, and Ear Plugs are recommended.

4 Block up or support raised machine and all lifted components securely before putting hands or feet under or working underneath any lifted component to prevent crushing injury or death from sudden dropping or inadvertent operation of controls. Make certain that area is clear before lowering or folding.

5 Before transporting, put Lift Lever in detent or full-lift position. Install Transport Safety Devices securely on folding implements. Slow down when turning and on hillsides.

- Install **Restrictor in folding circuit to slow down lowering and unfolding if action is faster than is desirable.

6 Make certain that SMV sign, Warning Lights, and Reflectors are clearly visible. Follow local traffic codes.

7 Never operate with Flail Mower or Folding Section raised if passersby, bystanders or traffic are in the area to reduce possibility of injury or death from objects thrown by Blades under Shields or implement structure.

8 Before dismounting, secure flail mower in transport position or lower to ground.

- Put tractor in park or set brake, disengage PTO, stop engine, remove key, and wait until noise of rotation has ceased to prevent entanglement in rotating parts which may cause injury or death.
- Never mount or dismount a moving vehicle. Crushing from runover may cause injury or death.

<p>5. TRANSPORT SAFELY, LOCK UP.</p>	<p>6. USE SMV, LIGHTS, & REFLECTORS.</p>	<p>7. DONOT OPERATE WITH MOWER OR WING RAISED.</p>	<p>8. DO NOT MOUNT OR DISMOUNT WHILE MOVING.</p>
---	---	---	---

PART NO.
LOCATION

002369
HYDRAULICTANK

PELIGRO

Si No Lee Ingles, Pida Ayuda a Alguien Que Si Lo Lea. Para Que le Traduzca las Medidas de Seguridad.

LEA EL INSTRUCTIVO

00725746

00725746
INSIDE OF CAB

DANGER

THROWN OBJECTS

CUTTING BLADES

KEEP AWAY - ROTATING BLADES

BEING HIT BY THROWN OBJECTS OR CONTACTING ROTATING BLADES CAN CAUSE INJURY OR DEATH.

- Stop mowing if passersby enter the area of thrown objects (See Operator's Manual).
- Use special care if Mower Head or Wing is raised off the ground. (See Manual).
- Operate only if all Guards-Deflectors are in place and in good condition.

00769737

00769737
MOWER DECK

SAFETY



PART NO.
LOCATION

00758194
MOWER DECK



02962764
MAIN BOOM, SECONDARY BOOM, MAIN FRAME



02962765
MAIN FRAME

02965262
HYDRAULICTANK

SAFETY

DANGER

CUTTING BLADES



THROWN OBJECTS



KEEP AWAY - ROTATING BLADES

BEING HIT BY THROWN OBJECTS OR CONTACTING ROTATING BLADES CAN CAUSE INJURY OR DEATH

- Stop mowing if passersby enter the area of thrown objects. (See Operator's Manual)
- Use special care when Flail or Wing is raised off the ground. (See Oper. Manual)
- Operate only if all Guards-Deflectors are in place and in good condition.

PART NO.
LOCATION

02967668
MOWER DECK

02971123
HYDRAULICTANK

03200285
OUTSIDE OF CAB

22645
INSIDE OF CAB

22839
MOWER DECK

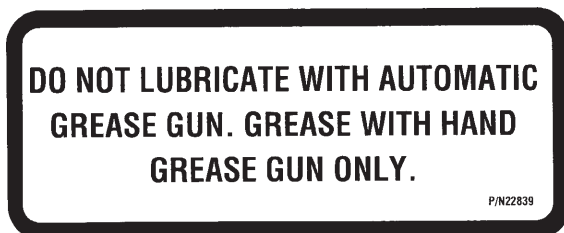

SAFETY



PART NO.
LOCATION

22840
INSIDE OF CAB



24028
MOWER DECK

25387
INSIDE OF CAB



10" x 5.5" 31522
MOWER DECK, MAIN BOOM
18.25" x 10" 31523
HYDRAULIC TANK

SAFETY



PART NO.
LOCATION

27001
INSIDE OF CAB



31935
INSIDE OF CAB

DANGER

1. EACH REAR WHEEL MUST HAVE A MINIMUM OF 1500 POUNDS CONTACT WITH THE SURFACE TO PREVENT LATERAL INSTABILITY AND POSSIBLE TIP-OVER WITH BODILY INJURY. WIDEN WHEEL TREAD AND ADD WEIGHTS IF NEEDED. SEE MANUAL OR CALL TIGER CUSTOMER SERVICE FOR COUNTERWEIGHT PROCEDURE.



1.
2. TRANSPORT CAREFULLY! SLOW DOWN EVEN MORE ON SLOPES AND WHEN TURNING; NEVER TURN UP A SLOPE SHARPLY OR AT HIGH SPEED; AND USE EXTRA CARE IN ROUGH OR BUMPY AREAS TO PREVENT OVERTURN AND POSSIBLE CRUSHING INJURY OR DEATH. IF YOUR VIEW TO THE REAR IS BLOCKED, IT IS YOUR RESPONSIBILITY TO INSTALL MIRRORS THAT PROVIDE A REAR VIEW TO PREVENT ACCIDENTS FROM BLIND SPOTS.



2.
3. REAR-MOUNTED BOOM MOWERS MOVE CENTER OF GRAVITY TO THE REAR AND REMOVE WEIGHT FROM FRONT WHEELS. ADD FRONT BALLAST UNTIL AT LEAST 20% OF TRACTOR'S WEIGHT IS ON FRONT WHEELS TO PREVENT REARING UP, LOSS OF STEERING CONTROL, AND POSSIBLE INJURY.



3.
4. NEVER OPERATE UNIT WITHOUT AN OPS (OPERATOR PROTECTIVE STRUCTURE) OR CAB TO PREVENT INJURY FROM OBJECTS THROWN FROM GROUND AND OVERHEAD TRIMMING. STOP CUTTING IF ANYONE IS WITHIN 100 YARDS.

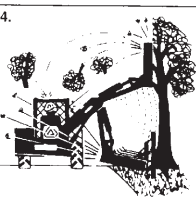

4.
5. KEEP THE BOOM AND CUTTERHEAD AT LEAST 10 FEET FROM ELECTRIC LINES AND PIPE LINES TO PREVENT ACCIDENTAL CONTACT AND POSSIBLE SERIOUS INJURY OR EVEN DEATH.



5.
6. WHEN TRANSPORTING BOOM MOWERS ON A TRUCK OR TRAILER, THE HEIGHT OR WIDTH MAY EXCEED LEGAL LIMITS. CONTACT WITH SIDE OR OVERHEAD STRUCTURES OR POWER LINES CAN CAUSE SERIOUS INJURY OR DEATH. LOWER BOOM TO REDUCE HEIGHT AND/OR REMOVE MOWING HEAD TO REDUCE WIDTH TO THE LEGAL LIMITS, IF NEEDED.

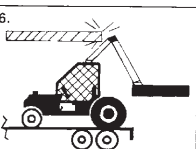

6.

32707

32707
HYDRAULIC TANK



42350
MOWER DECK

SAFETY

ATTENTION

**SERVICE HYDRAULIC SYSTEM
WITH UNIVERSAL TRACTOR
HYDRAULIC OIL.**

32708

PART NO.
LOCATION

32708
HYDRAULICTANK

CAUTION

For your safety and to guarantee optimum product reliability, always use genuine TIGER replacement parts. The use of inferior "will-fit" parts will void warranty of your TIGER implement and may cause premature or catastrophic failure which can result in serious injury or death. If you have any questions concerning the repair parts you are using, contact TIGER, 3301 N. LOUISE AVE., SIOUX FALLS, SD 57107

32709

32709
INSIDE OF CAB

33224
MOWER DECK

Tiger™

33438
MAIN BOOM

SAFETY

PART NO.
LOCATION

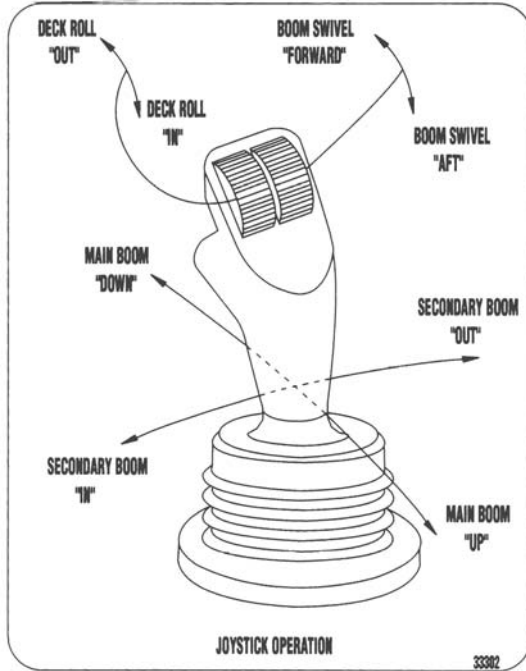

33302
INSIDE OF CAB

MOWING SAFETY TIPS

- Read & understand the Operators Manual.
- Wear Your Seat Belt.
- Keep all shields and guards in place.
- Make sure equipment is in proper working condition.
- Never attempt to get off or on a moving tractor.
- Never allow riders on tractor or equipment.
- Only start the tractor from the seat with the key.
- Always inspect the area before mowing. Remove all foreign debris.
- Always keep bystanders and coworkers a minimum of 300 feet away.
- Never allow the mower blades to contact solid objects or foreign material.
- Never approach rotating elements.
- Disengage the PTO, place transmission in "Park", set parking brake, shut off engine, and remove key and wait until all rotating motion has stopped before leaving seat.

Tiger

33743

33743
INSIDE OF CAB

SAFETY



PART NO.
LOCATION
RED 42399
REFLECTIVE TAPE
MOWER DECK

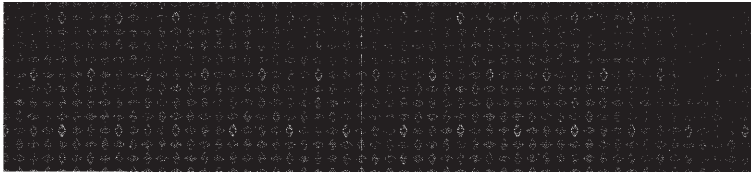

AMBER 42400
REFLECTIVE TAPE
MOWER DECK



6T3217
MOWER DECK



6T3219
INSIDE OF CAB

6T3220
FRONT PUMP MOUNT

SAFETY



PART NO.
LOCATION

6T3221
INSIDE OF CAB

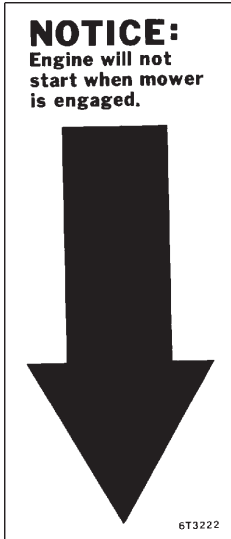

6T3222
INSIDE OF CAB



6T3224
MOWER DECK

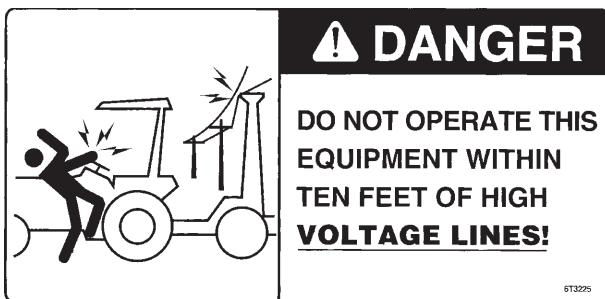

6T3225
INSIDE OF CAB

SAFETY

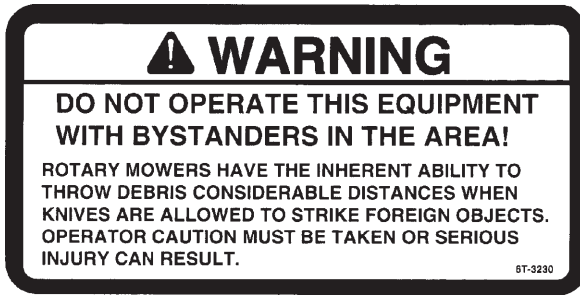

PART NO.
LOCATION

6T3230
INSIDE OF CAB



6T3231
INSIDE OF CAB



6T3233
HYDRAULICTANK



6T3234
INSIDE OF CAB



6T3236
MOWER DECK

SAFETY

⚠ WARNING

WHEN CUTTING HEAVY BRUSH, BLADE BOLTS SHOULD BE INSPECTED HOURLY AND RETORQUED TO 600 FT. LBS.

6T-3237

6T3237

PART NO.
LOCATION
6T3237
INSIDE OF CAB

DOWN ↑ MAIN BOOM ↓ UP	OUT ↑ SECONDARY BOOM ↓ IN	OUT ↑ DECK ROLL ↓ IN	FORWARD ↑ SWING ↓ BACKWARD
-----------------------------------	---------------------------------------	----------------------------------	--

6T-3241

6T3241

6T3241
INSIDE OF CAB

DOWN ↑ MAIN BOOM ↓ UP	OUT ↑ SECONDARY BOOM ↓ IN	OUT ↑ DECK ROLL ↓ IN	FORWARD ↑ SWING ↓ BACKWARD	CLOSE ↑ SHIELD ↓ OPEN
-----------------------------------	---------------------------------------	----------------------------------	--	-----------------------------------

34206

34206
INSIDE OF CAB

<p style="text-align: center;">⚠ WARNING</p> <p style="font-size: x-small;">IT IS RECOMMENDED THAT THE BOLT AND LOCK NUT BE REPLACED WHENEVER BLADES ARE REPLACED. REPLACE THESE ANY TIME THEY ARE DAMAGED OR WORN AS FAILURE TO DO SO CAN LEAD TO BLADES COMING OFF CAUSING SERIOUS INJURY OR DEATH.</p>	<p style="text-align: center;">IMPORTANT</p> <ul style="list-style-type: none"> • WHEN REPLACING BLADES, IT IS RECOMMENDED THAT ALL BLADES BE REPLACED FOR PROPER BALANCE TO AVOID EXCESSIVE VIBRATIONS WHICH CAN DAMAGE SPINDLE ASSEMBLY. • SEE YOUR OPERATOR'S MANUAL FOR PROPER INSTALLATION INSTRUCTIONS. <p style="text-align: right; font-size: x-small;">6T-3243</p>
--	--

6T3243
INSIDE OF CAB

GREASING INSTRUCTIONS

CUTTER SHAFT BEARING

GREASE EVERY 8 HRS. OR DAILY

NOTE: If unusual environmental conditions exist-extreme temperatures, moisture, or contaminants-more frequent lubrication is required.

6T3249A

6T3249A
MOWER DECK

GREASING INSTRUCTIONS

GROUND ROLLER BEARING

GREASE EVERY 8 HRS. OR DAILY

NOTE: If unusual environmental conditions exist-extreme temperatures, moisture, or contaminants-more frequent lubrication is required.

6T3261

6T3261
MOWER DECK

SAFETY

⚠ **WARNING**

**DO NOT OPERATE MOWER
WITH SAFETY SHIELD REMOVED.**

TB1011

TB1011
MOWER DECK



Tiger Corporation

800-843-6849
www.tiger-mowers.com

Description	Application	General Specification	Recommended Lubricant
Tractor Hydraulics	Reservoir	JD-20C	Mobilfluid® 424
Mower Hydraulics Cold Temperatures 0°F Start-up Normal Temperatures 10°F Start-up Normal Temperatures 15°F Start-up High Operating Temperatures Above 90°F Ambient	Reservoir	ISO 46 Anti-Wear/ Low Temp JD-20C ISO 46 Anti-Wear ISO 100 Anti-Wear	Mobil DTE® 15M Mobilfluid® 424 Mobil DTE® 25 Mobil DTE® 18M
Flail Rear Gearbox	Reservoir	PAO Synthetic Extreme Pressure Gear Lube	Mobilube SHC® 75W-90, Mobil 1 Synthetic Gear Lubricant
Cutter Shaft and Ground Roller Shaft (Flail)	Grease Gun	Lithium Complex, NLGI 2 ISO 320	Mobilgrease® CM-S
Drive Shaft Coupler (Rotary and Flail)	Grease Gun	Lithium Complex, NLGI 2 ISO 320	Mobilgrease® CM-S
Boom Swivel, Boom Cylinder Pivots (Rotary and Flail Boom Type)	Grease Gun	Lithium Complex, NLGI 2 ISO 320	Mobilgrease® CM-S
Deck Boom Pivot & Deck Stop Adjustment (Rotary and Flail)	Grease Gun	Lithium Complex, NLGI 2 ISO 320	Mobilgrease® CM-S
Deck Spindle (Rotary)	Grease Gun	Tiger Spindle Lubricant	Mobilith SHC 220

For Mobil product information, availability, or technical information, call 1-800-662-4525.

Tiger PN 34852

34852
HYDRAULIC TANK

SAFETY



ITEM	PART NO.	QTY.	DESCRIPTION
	50023	AVAIL	MANUAL CANISTER COMPLETE
1	00776031 33997	1 1	ROUND MANUAL CANISTER DECAL, SHEET, MANUAL CANISTER
2		*	DECAL
3		*	DECAL
4		*	DECAL
5	*	AVAIL	SPECIFIC PRODUCT MANUAL
6	33753	1	E M I SAFETY MANUAL
7	34296	1	FRONT ADHESIVE PAD
8	34297	1	REAR ADHESIVE PAD
9	6T1823	4	ZIPTIE 14" LONG

NOTE:

The manual canister can be bolted, zip tied or adhered to a variety of surfaces. Locate a protected area within the view of the operator Then select an installation method and attach the canister. **CAUTION - AVOID DRILLING HOLES INTO UNKNOWN AREAS**,wires and other parts may be located behind these areas. When adhering the canister to a surface, thoroughly clean that surface before installing the canister.

SAFETY

FEDERAL LAWS AND REGULATIONS

This section is intended to explain in broad terms the concept and effect of federal laws and regulations concerning employer and employee equipment operators. This section is not intended as a legal interpretation of the law and should not be considered as such.

Employer-Employee Operator Regulations

U.S. Public Law 91-596 (The Williams-Steiger Occupational and Health Act of 1970) OSHA

This Act Seeks:

“...to assure so far as possible every working man and woman in the nation safe and healthful working conditions and to preserve our human resources...”

DUTIES

Sec. 5 (a) Each employer-

(1) shall furnish to each of his employees employment and a place of employment which are free from recognized hazards that are causing or are likely to cause death or serious physical harm to his employees;

(2) shall comply with occupational safety and health standards promulgated under this Act.

(b) Each employee shall comply with occupational safety and health standards and all rules, regulations and orders issued pursuant to this Act which are applicable to his own actions and conduct.

OSHA Regulations

OSHA regulations state in part: “At the time of initial assignment and at least annually thereafter, the employer shall instruct every employee in the safe operation and servicing of all equipment with which the employee is, or will be involved.”

Employer Responsibilities:

To ensure employee safety during Tractor and Implement operation, it is the employer's responsibility to:

1. Train the employee in the proper and safe operation of the Tractor and Implement.
2. Require that the employee read and fully understand the Tractor and Implement Operator's manual.
3. Permit only qualified and properly trained employees to operate the Tractor and Implement.
4. Maintain the Tractor and Implement in a safe operational condition and maintain all shields and guards on the equipment.
5. Ensure the Tractor is equipped with a functional ROPS and seat belt and require that the employee operator securely fasten the safety belt and operate with the ROPS in the raised position at all times.
6. Forbid the employee operator to carry additional riders on the Tractor or Implement.
7. Provide the required tools to maintain the Tractor and Implement in a good safe working condition and provide the necessary support devices to secure the equipment safely while performing repairs and service.

Child Labor Under 16 Years of Age

Some regulations specify that no one under the age of 16 may operate power machinery. It is your responsibility to know what these regulations are in your own area or situation. (Refer to U.S. Dept. of Labor, Employment Standard Administration, Wage & Home Division, Child Labor Bulletin #102.)

SAFETY

ASSEMBLY SECTION

ASSEMBLY

Before attempting to mount or service your Tiger mower, it is important to read and understand all of the information in the Safety section of this manual.

Check complete shipment list against the packing list to make sure there are no shortages. Make certain the tractor model is the appropriate one for the mower received!

CAUTION!



Use a floor jack, hoist or fork lift to lift or raise heavy parts whenever possible whether mentioned or not.

Read and understand the entire assembly section instructions before attempting to mount your Tiger mower. Refer to the parts section of this manual for detailed illustrations to locate all parts.

TRACTOR PREPARATION

- A: Remove right hand steps.
- B: Disconnect battery cables.
- C: Remove battery, battery box and existing bracket.
- D: Remove engine side panels, or raise hood to access front pulley.
- E: Remove plugs from tractor casting where main frame and pump mount will be attached.
- F: Install battery bracket supplied in the kit using existing hardware.

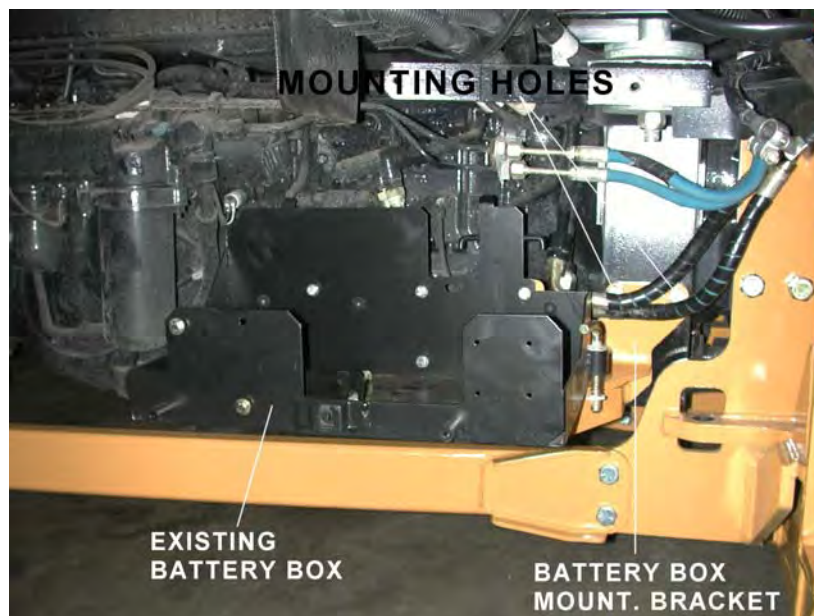

ASSEMBLY

ADJUSTING REAR WHEELS

Raise rear of tractor onto jack-stands. Follow the instructions in the tractor owners manual for adjusting tires and rims to 72" center for side mounted mowers and 79.8" for boom mowers. NOTE: This may require switching the wheels to opposite sides of tractor.

CRANKSHAFT ADAPTER

If necessary remove the four cap-screws from the crankshaft pulley. Then install the crankshaft adapter and spacer to the pulley with cap-screws and lock-washers as shown in the parts section.

CABLE CONTROL LEVER STAND

Place the front edge of the support bracket 2 3/4" back from the lower right front window. Rotate stand to be 2" from the right door frame as shown below. Be sure that the location of the stand will allow clearance between the cable control handles and all existing interior levers, etc.

Drill 3 holes to match control bracket and secure with cap-screws and nylock nuts noted in parts section.

Cut a 2 1/4" hole in the fender from inside the cab. This hole is to be located 2-1/2" up from floor, and 4" from the metal edge by the right door. Install trim lock around the metal edges of the hole, then route the cables through the hole. Next, wrap the cables with the 6" split hose at the point they pass through the hole, and secure with zip-ties.

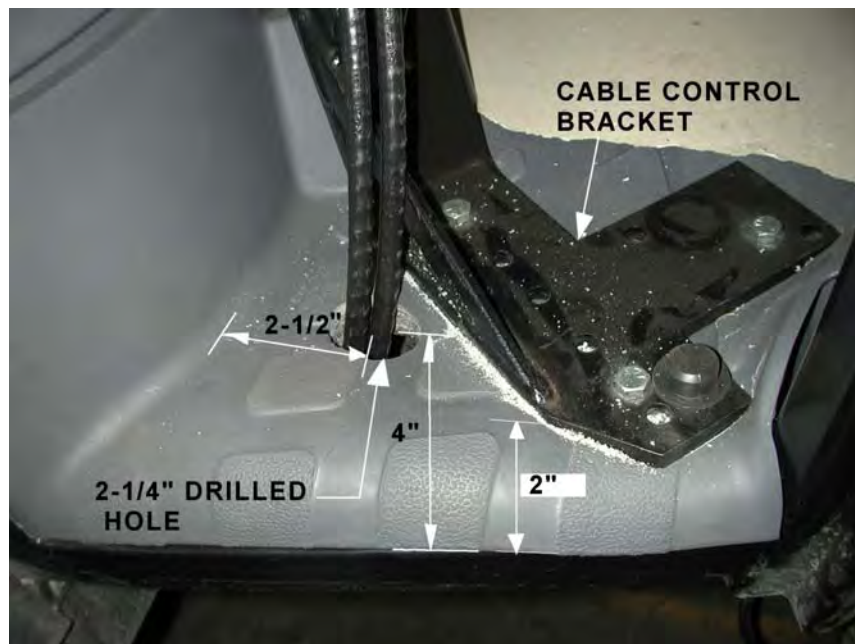

ASSEMBLY

LIFT VALVE MOUNT

Install the valve mounting bracket to the inside of the right and left rear fender frame tube as shown below. Align the valve mounting plate with the drilled holes. Mark the center of one of the holes above and in line with the slotted holes in the valve plate. Do not use any holes that will be used to mount the valve on the plate.

Mount the lift valve with the supplied hardware. Refer the parts section for the details.

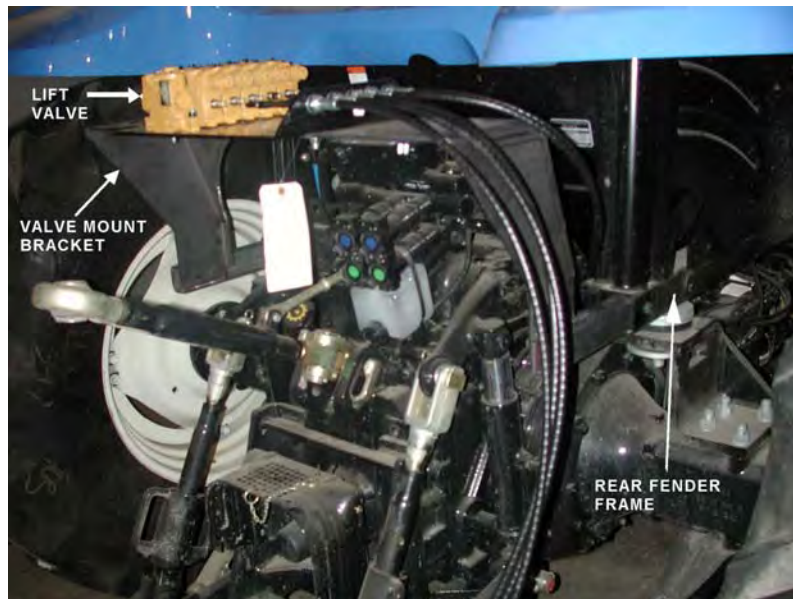

MAIN FRAME MOUNTING

Raise front of tractor as needed and slide the main frame under tractor from right hand side. With an overhead hoist and / or jack-stands, raise the frame up to the correctly matching mounting holes. Install spacer blocks and shims as needed. Install cap-screws and all other hardware as shown in main frame parts section. Remove the cap-screws one at a time and apply a thread locking agent, then reinsert the cap-screws and tighten / torque to values noted in the torque chart located in the maintenance section of this manual.

SOLENOID BRAKE VALVE

Install a solenoid valve the mounting bracket with the supplied hardware. While installing fittings to the brake valve, the electrical coil on the spool must be removed to make room. When reinstalling the coil, it is important to use no more than 5 ft. lbs. (or 60 in. lbs.) torque. Over torque to the coil will result in hydraulic failure of spool.

ASSEMBLY

DANFOSS PRIORITY VALVE USED ON STANDARD TSA 110, 115 & 135

The DanFoss lift valve needs a priority valve and a NH priority valve plug in the tractor rear remotes for the proper hydraulic flow. Torque the body to the plug first to 94Nm and then the small end to 15Nm. The ports used are directly under the valve mounting plate. The illustration below shows these ports are in a row. From left to right the ports are used for “return from Danfoss valve”, “plug to allow activation of the next two ports”, “return from EF port on priority valve” and “pressure to valve”.

The pressure hose is routed from the tractor remotes to the “P” port of the Danfoss priority valve. The pressure hose to the Danfoss valve runs from the “CF” port to the pressure port of the lift valve.

The load sense line is routed from the load sense port of the Danfoss valve to the “LS” port of the priority valve. The power beyond hose is routed from the “EF” port of the priority valve to the tractor remotes.

The return hose runs from the return port of the Danfoss valve to the tractor remotes. For more information refer to the Parts Section pages for a complete diagram of the

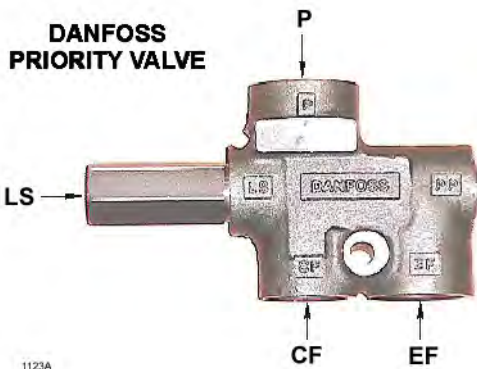

NEW HOLLAND TRACTOR REMOTE PRIORITY VALVE PLUG



NEW HOLLAND TRACTOR REMOTES

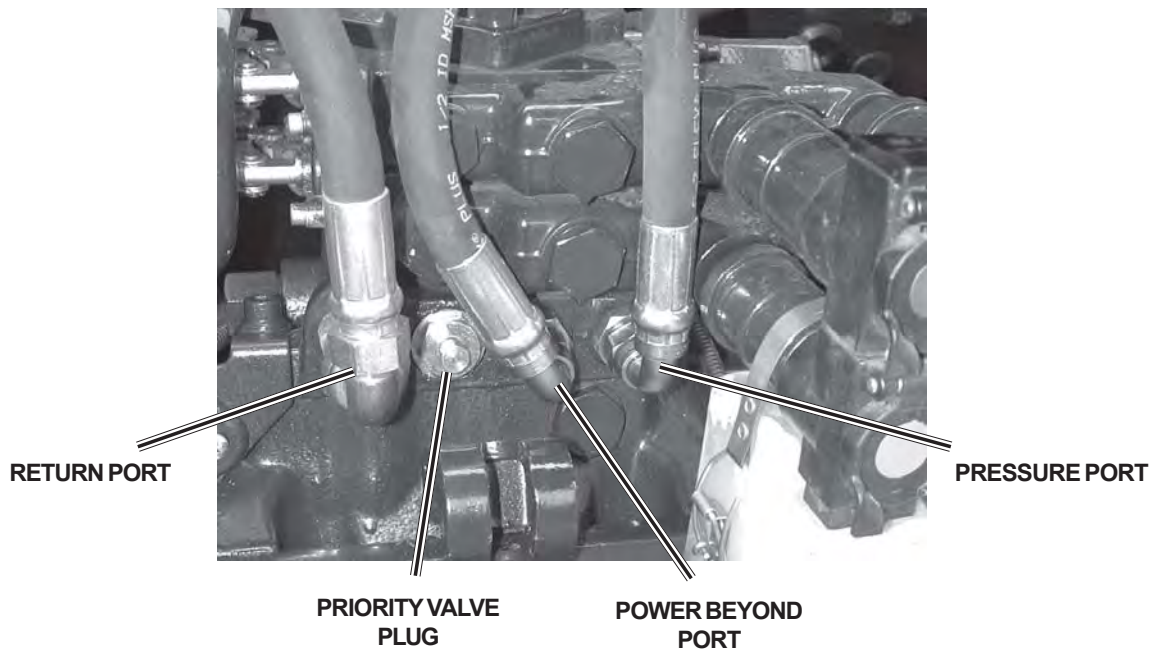

ASSEMBLY

POLY-CARBONATE SAFETY WINDOW

NOTE: This should be done before mounting the main frame.

1. Disconnect gas shock at door. Remove the right side cab door from tractor cab by removing hinge pins.
2. Remove the existing hardware and discard factory glass door .
3. Place small bead of adhesive seal in the botom of the trim lock bubble bead.
4. Install trim lock bubble seal on polycarbonate starting at the center bottom horizontal portion.
5. Install existing hardware removed from glass door on the polycarbonate.
6. Install the polycarbonate assembly in the cab with existing and supplied hardware.
7. Press polycarbonate into place at upper front corner .
8. Then drill 3/16" pilot hole through polycarbonate and corner gusset of door jam.
9. Locate hole 1-1/4" from the edge of the lower rounded feature of the corner gusset and center it from each end. Then drill out hole in polycarbonate with 15/32" diameter bit that is **ONLY** used for polycarbonate.
10. Drill out hole in gusset with 3/8" diameter bit for steel.
11. Install the poly door into place where factory door was removed (upper right rear first). Refer the parts section for the details.
12. Install grommet into hole in polycarbonate. Then install supplied 1/4" nut into corner gusset.
13. Secure upper right corner with supplied washer and capscrew. Refer to Parts section for the details.

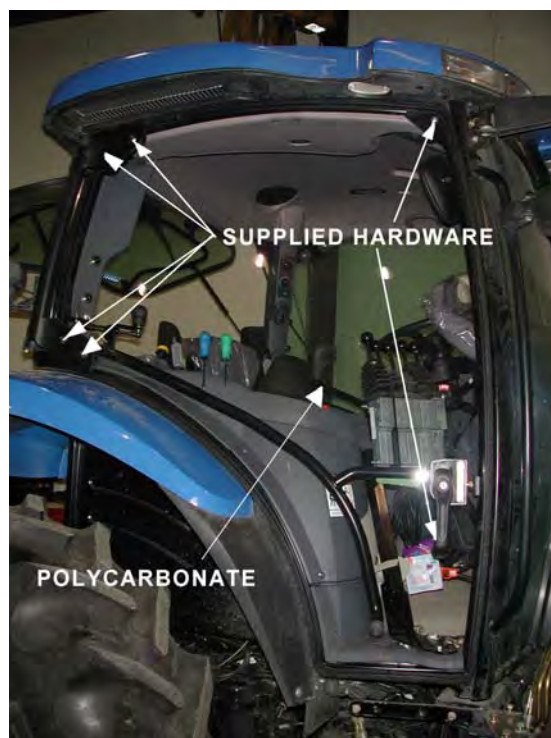

ASSEMBLY

MIRROR MOUNT

1. Remove the existing mirror bracket and mirror from the cab.
2. Remove the mirror and knob from existing bracket.
3. Install the supplied bracket using supplied hardware on the cab as shown below.
4. Install the mirror with the knob on the supplied bracket as shown below. Refer to the Parts section for details.



FRONT WORKLAMP RELOCATION

1. Cut the right side front hand rail from the bottom of worklamp to the bottom of the hand rail.
2. Bend the hand rail inside to avoid the boom collision with the worklamp.

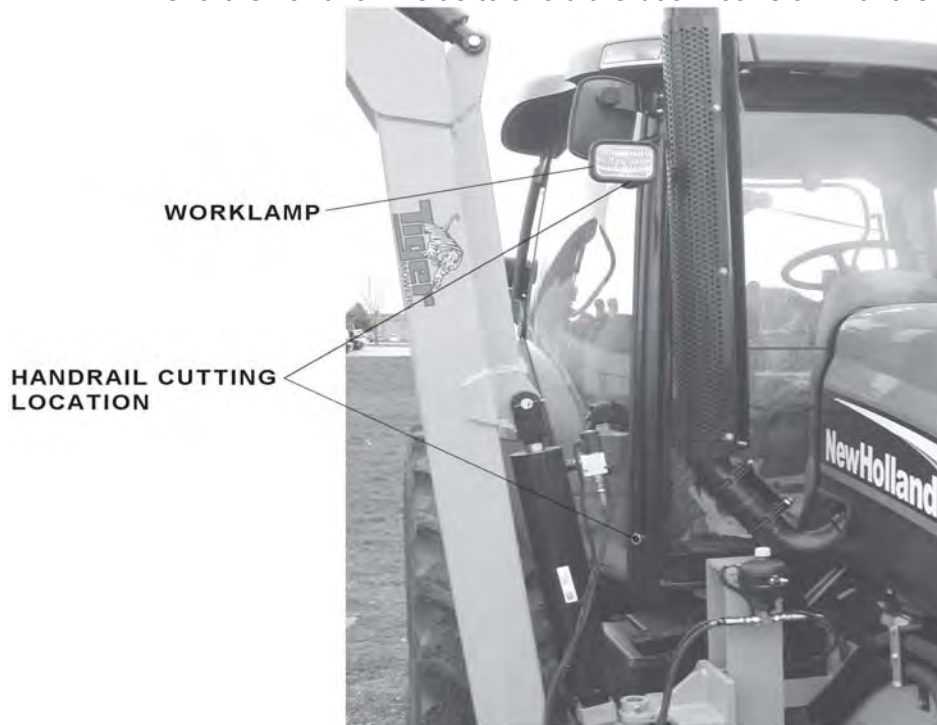

ASSEMBLY

EXHAUST MOUNT

NOTE: This should be done after mounting the main frame.

1. Cut the tractor hood as shown in pic. # 1 to accommodate modified exhaust turbo tube.
2. Remove the muffler from existing turbo tube.
3. Remove existing turbo tube from tractor turbo.
4. Install the exhaust mounting bracket and supporting brace.
5. Cut the existing tube at turbo end 4-3/8" from hole center as shown in pic. # 2 and 3. Discard remaining portion of existing tube.
6. Install the turbo end of existing tube to the tractor turbo.
7. Connect the supplied tube to the turbo end of existing tube using the sealing clamp as shown in pic. # 4. Do not tighten the hardware.
8. Install the exhaust clamp to the exhaust mounting bracket with the supplied hardware. Refer parts section for the details.
9. Tighten the turbo existing hardware first and then the rest of the hardware.
10. Cut the muffler sweep off at the top and replace with a raincap, if necessary for shipping, as shown in pic. # 5. Then install muffler to the turbo tube with the existing hardware.

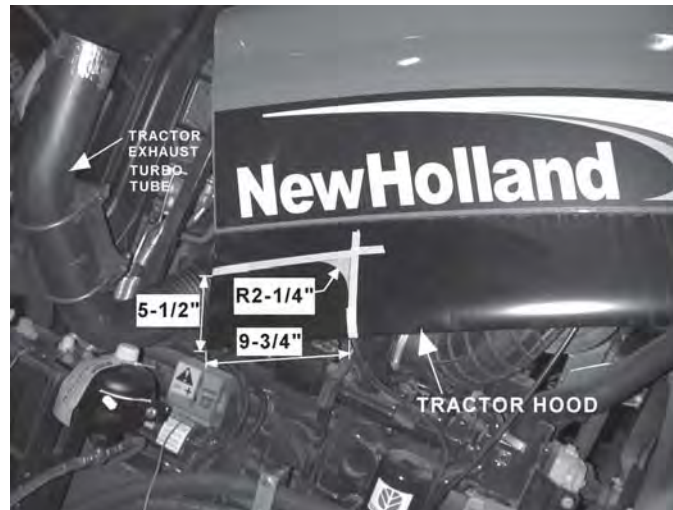

Picture # 1

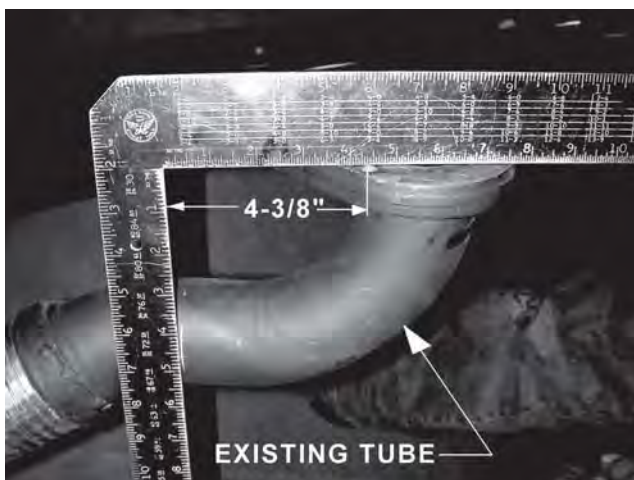

Picture # 2

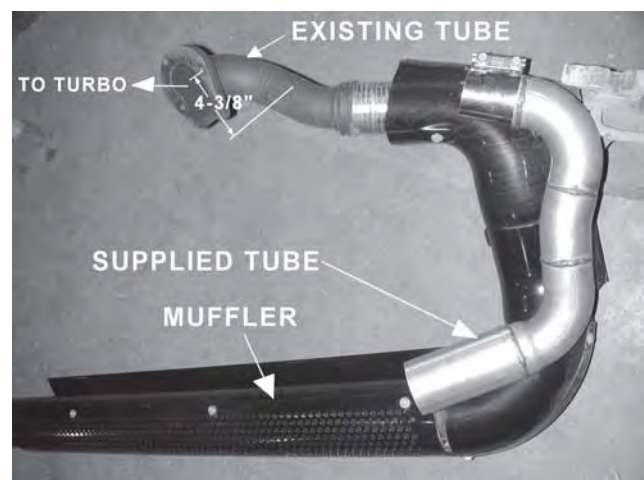

Picture # 3

ASSEMBLY

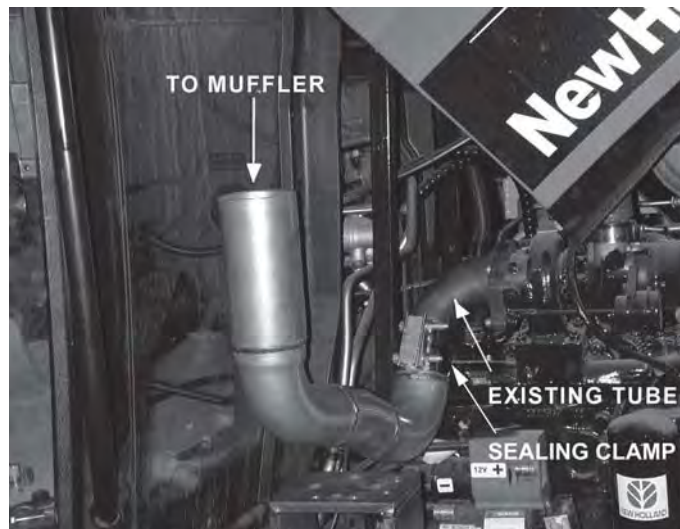

Picture # 4

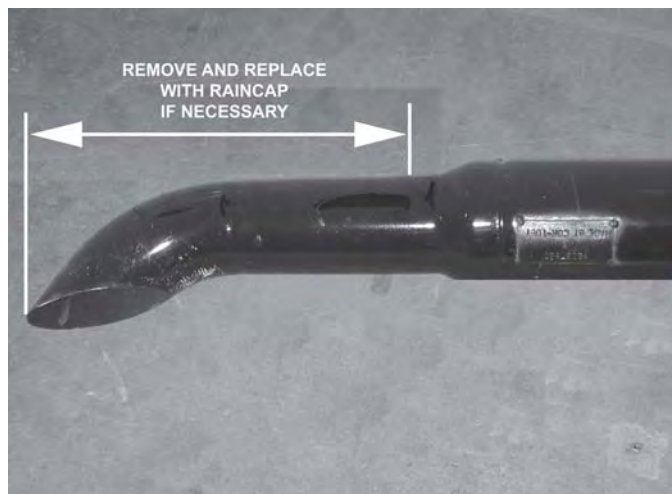

Picture # 5

ASSEMBLY

SWITCH MOUNTING

Refer to the Parts section for wiring diagrams. Remove top instrument panel (tach, and hour meter) for access to the wires.

Route the red and green wire from the switch box wires from the switch box to the bottom right corner of the instrument panel near window. Connect the red wire to the white wire. (hot when key in on position)

NOTE ONLY FOR ELECTRONIC V VALVE: +12 VOLTS ELECTRICAL POWER MUST BE TAKEN FROM A SOURCE LOCATION WHERE IT IS LIVE ONLY WHEN THE IGNITION SWITCH IS IN THE "ON" POSITION. THIS WIRE MUST BE FUSED AT THE SOURCE LOCATION.

Route the white wire to connected the hydraulic solenoid valve.

The switch box is to be secured to the operators side of the control handles, or valve stand.

The green wires will connect to the neutral safety switch wires (white with yellow strip), under the cowl panel.



BEFORE WIRING

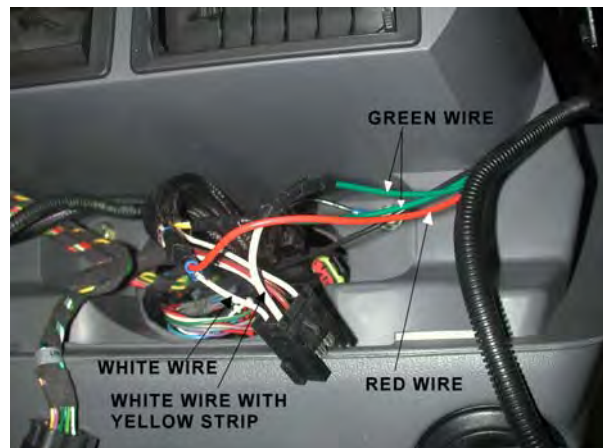

AFTER WIRING

HYDRAULIC TANK INSTALLATION

Install all fittings and tubes into tank and tank filter as shown in parts section illustration. Install the 2 sight glass into back side of the tank. Install the temperature sensor or pipe plug into the side of the tank.

Place the tank in the mounting bracket on the main frame with fittings toward tractor and filter toward the cab.

Secure the tank in the mounting bracket with the tank strap and nylock nuts.

Install the filter gauge into the filter housing so that it points to the rear of the tractor and is clearly visible to the operator .

Locate the tank breather and reducer bushing (bushing may be already installed in the tank along with many of the for-mentioned parts). These will be installed after tank is filled with oil. The oil level must be visible in lower sight glass but not visible in upper sight glass.

ASSEMBLY

WEATHER-PACK/METRI-PACK ASSEMBLY

These instructions apply to both Weather-Pack and Metri-pack connectors.

NOTE: Use the specific tool for the type of connector you are assembling.

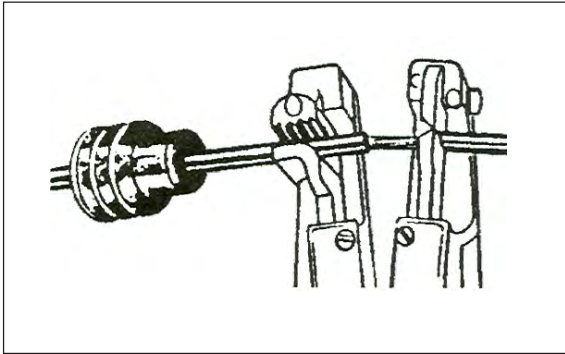

1. Apply seal to cable, before stripping insulation.



2. Align seal with cable insulation.

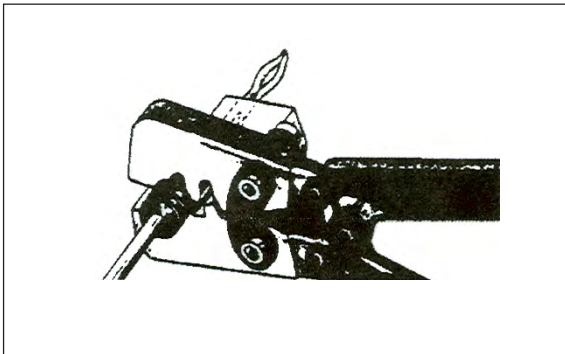

3. Put terminal in crimping tool, then position wire and seal in place.

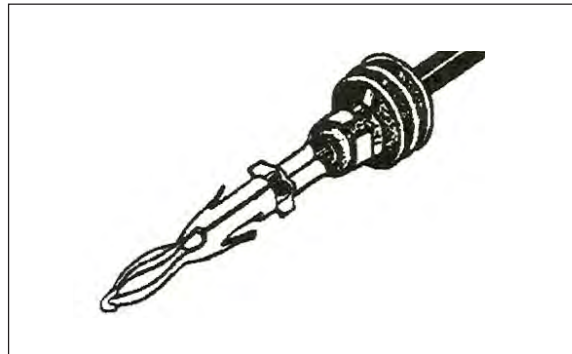

4. Crimp and visually inspect for a good crimp before installing in connector body.

ASSEMBLY

REAR STOW BENGAL HOSE ROUTING

WARNING NOTE: The sudden release of hydraulic pressure could cause the sudden movement of very heavy parts. Anyone in the way of these parts could be severely hurt or killed. DO NOT ALLOW these hydraulic hoses to BREAK or BURST in order to prevent hydraulic failure. Make sure the hoses do not pinch or stretch as boom moves. Measure TWICE, check TWICE then proceed with caution.

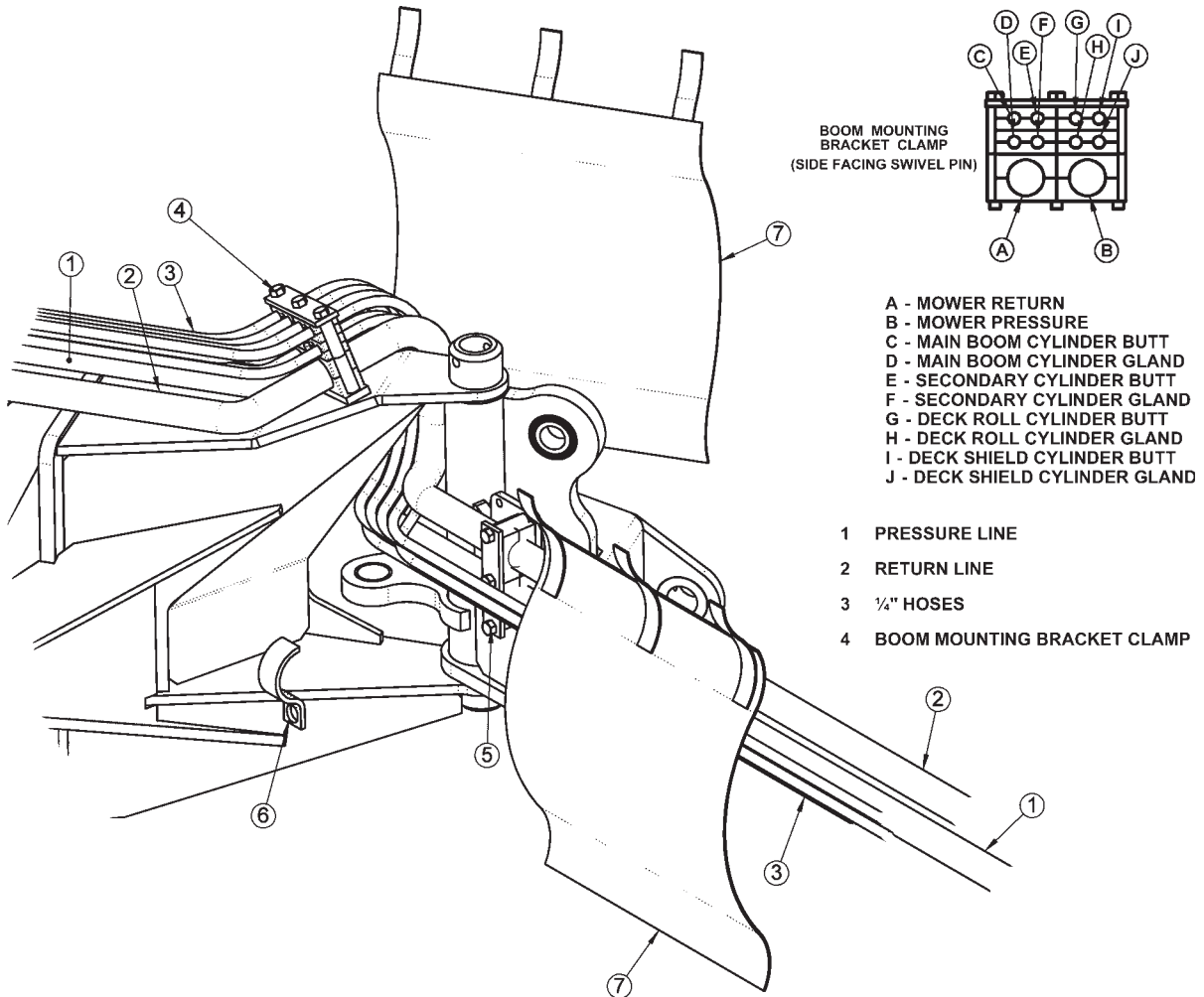

Route the hoses through the space between the swivel and the boom mounting bracket. Connect the hoses to the preformed tubes and move the boom arm to a few feet from full forward. Assemble the swivel clamp and place the return hose for the motor on top and the pressure line on the bottom. Place the 1/4" hoses in the "C" clamp and add it to the bottom screw of the swivel clamp. Next, make sure there is enough slack for all hoses to pivot at the joint where the main boom arm bends in the swivel, as shown in the next image, and tighten the hoses in the clamp.

ASSEMBLY

BEFORE TIGHTENING HOSES IN CLAMP, MAKE SURE HOSES CAN PASS THROUGH CENTER POINT OF BOOM PIN. THIS WILL ENSURE PROPER HOSE LENGTH FOR ALL BOOM POSITIONS.

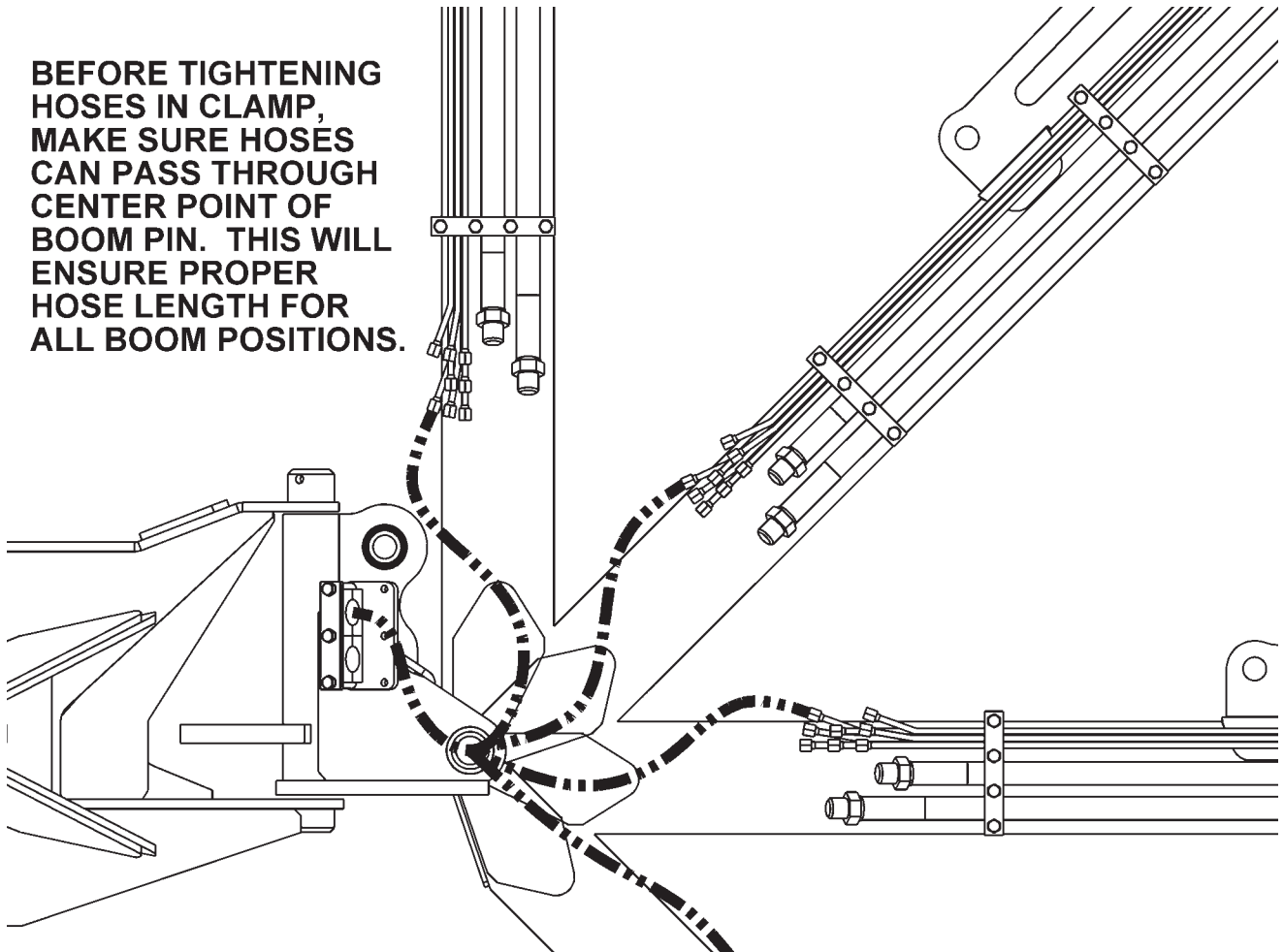

Arrange the hoses in the clamp that attaches to the boom mounting bracket as shown above, with the 1" motor hoses closest to the bracket and the return hose closest to the boom arm. Pull the hoses snug from the swivel to the mounting bracket clamps, when main boom is still forward, and tighten the hoses in the clamp.

Make sure the 1" motor hoses do not kink as the boom arm is moved into the stowing position. If this happens the motor hoses will have to be shortened, because there is too much hose between clamps.

ASSEMBLY

BOOM HYDRAULIC DIAGRAM

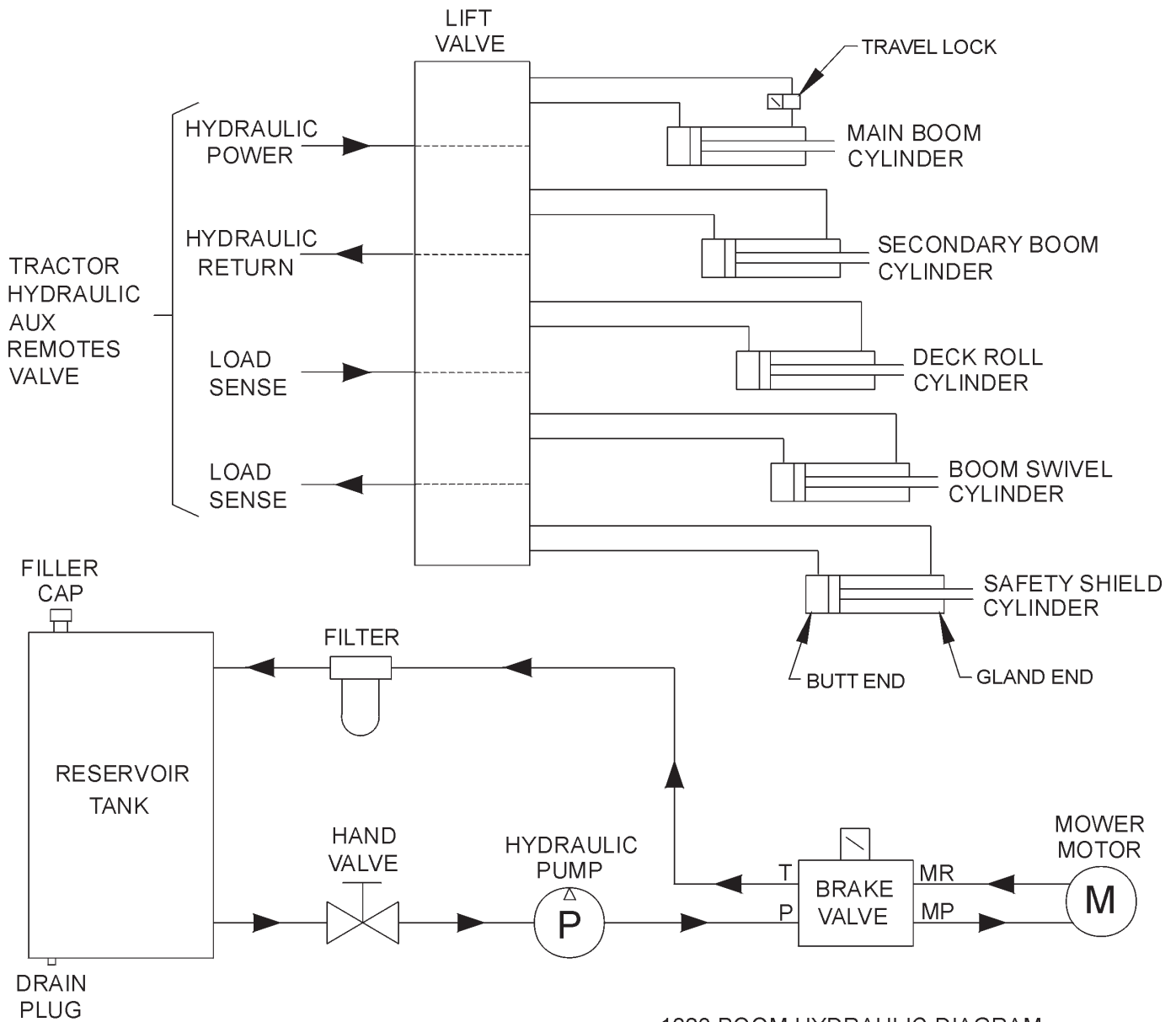

TEMPERATURE GAUGE MOUNTING

(OPTIONAL)

Mount the temperature gauge where it is clearly visible to the operator . Attach the green (-) wire from the negative post on the gauge to a grounded bolt on the tractor frame. Remove paint if needed to make a good ground.

Remove the pipe plug from the side of the hydraulic reservoir , and install the temperature sensor using thread sealing tape. Run the white wire from the (S) sensor post of the gauge to the temperature sensor on the hydraulic reservoir tank.

ASSEMBLY

FRONT PUMP MOUNTING

Install the pump mounting bracket on the front of the tractor with cap-screws and lock-washers as shown in the parts section illustration. DO NOT tighten fasteners at this time.

Slide the pump drive shaft into the crankshaft adapter. The end with the shorter splines should be inserted into the adapter (if applicable).

Slide the splined drive shaft coupler onto the pump drive shaft. Install the pump onto the mounting bracket. NOTE: the shaft is offset to one direction, the pump should be installed with the offset side on top. Install hardware for securing pump to the pump mount, DO NOT tighten.

Align pump so that splined coupling can be moved back and forth by hand. Tighten pump mounting bolts in succession rechecking for spline coupling movement. Remove the pump mounting bracket bolts one at a time and apply a tread locking agent. Tighten these bolts in succession, again checking for free movement in the drive shaft. After all bolts are torqued, the end play on the drive shaft should be 1/16" to 1/8", and coupler should move freely with hand pressure. If end play is less than 1/16", grind the end of the shaft to achieve the proper end play. If there is more than 1/4" of end play, return the shaft with specifications for a longer shaft.

CAUTION: DO NOT START THE TRACTOR UNTIL ALL HOSES ARE ATTACHED, TANK IS FILLED WITH PROPER OIL AND BALL VALVES ARE OPEN! STARTING AT THIS TIME WILL CAUSE SERIOUS DAMAGE TO THE PUMP.

GENERAL HOSE INSTALLATION

Refer to the parts section for detailed information about hoses and fittings for this application.

When mounting the suction hose between the pump and the tank, the stainless steel bands that are provided must be used. CAUTION: DO NOT use regular hose clamps for this purpose.

For protection of hoses in contact with metal edges, wrap hoses with spit hose sections and fasten with hose clamps or zip ties as needed.

WHEEL WEIGHT MOUNTING

For all machines using a boom mower, a wheel weight will be required for the left side wheel. It will be necessary to mount the 1300 pound wheel weight in the wheel using the long cap-screws, lock-washers, flat-washers, and hex nuts per diagram in the parts section.

Installation is most easily done with a small fork lift, inserting a fork in the center slot of the wheel weight. The head of the cap-screws is to be toward the OUTSIDE of the weight, with flat-washers on both inside and out side of the assembly.

The left rear tire must also be filled with a mixture of water and calcium chloride at about five pound per gallon. Tire air pressure should be maintained at approximately 22 P.S.I.

ASSEMBLY

INSTALLING O-RING FITTINGS

Installing straight, 45 degree and 90 degree O-ring fittings requires that the O-ring, washer and nut (A) be up against the swivel body (B). Insert the swivel and turn in until the swivel is pointed in the right direction and the O-ring contact is made. Hold swivel in set direction with a wrench and turn the O-ring nut away from the swivel body and carefully tighten.

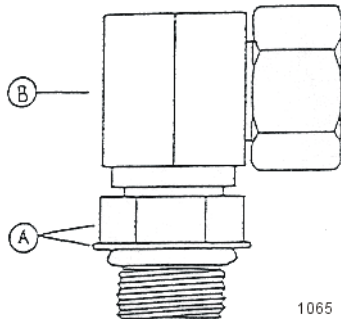

INSTALLING NATIONAL PIPE FITTINGS

Whenever installing a pipe fitting, wrap the threads clockwise (looking at the end) with teflon tape. In this way, the tape will be tightened when installed. NOTE: It is not necessary to tape O-ring fittings, or those installed in swivels.

BOOM ARM ATTACHMENT

If you are changing over from a side mounted mower you must first close the ball valves and remove the motor hoses from the motor to the solenoid valve. Also remove and replace any fittings that do not match the ones shown in the parts section diagram.

Next, disconnect all hoses from the control valve. Remove the pin that connects the lift cylinder to the mast on the main frame. Remove the inner draft beam pin.

At this point the mower should be loose from the tractor.

Remove the two spool valve and mount the four spool valve for the boom according the diagram in the parts section. Also refer to the parts section for the new hoses that will need to be used.

BOOM MOUNTING BRACKET

Using a floor jack and / or a hoist, raise the boom mounting bracket up to level and slide the bracket into position onto main frame as shown in parts section.

Install pin through main frame and bracket. Secure with cap-screw, lock-washer and hex nut through boss on main frame as shown.

Secure mounting bracket to main frame with the cap-screws, lock-washers, flat-washers, cut flat-washers and hex nuts provided. Secure using the two slotted holes on the bracket and main frame.

ASSEMBLY

SUB-FRAME AXLE BRACE MTG.

These units require the lower rear axle brace to be mounted under the right rear axle of the tractor. The other end of the axle brace mounts to the main frame lower right rear corner. Some shims may be required for proper fit of the main frame to the tractor, see main frame mounting in the part section on this manual. With all sub-frame connections hardware in place, it should fit tightly and level under the tractor. Be sure to use a thread locking agent on all capscrews and nuts that attach the frame to the tractor.

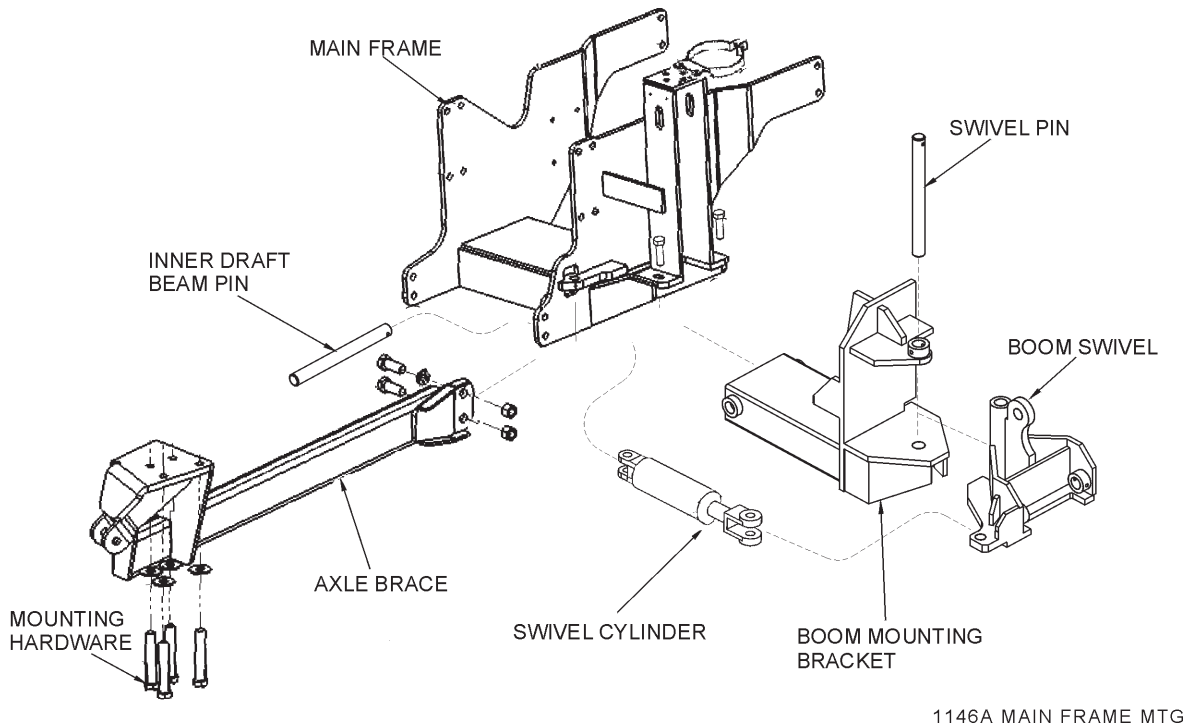

SWIVEL BRACKET MOUNTING

Install the boom swivel bracket onto the boom mounting bracket with the swivel pin. Secure the pin in place using the capscrews, etc. through the hole in the boss and pin. **NOTE:** The head of the capscrew must be toward the front of the tractor.

Install all new swivels and fittings on the swing cylinder with swivel openings facing each other. Fittings will vary in type and direction depending on your application, refer to your parts section for more detail.

Install bushings (with split facing the direction of the grease zerk hole) in the main frame anchor for the swing cylinder. This may already be done for you.

Install the swing cylinder between the main frame cylinder anchor and the boom swivel bracket with the clevis pins. Insert roll pins through the top hole in the clevis pins, and secure the bottom of the pins with the hairpin clips.

Now the hoses can be attached from the control valve to the swing cylinder.

ASSEMBLY

PREFORMED TUBE INSTALLATION

Lay booms on floor so the side with the nuts welded on is up. If mounting a ditcher head, only the main boom tube installation is required. Locate all tube clamps and install them loosely in the welded nuts on the left side of the booms.

Arrange the tubes and hoses as outlined in the parts section diagram. Install the smaller tube closest to the boom arm, being careful not to pinch the tubes. Place the large tubes outside of the small tubes. Snug all clamp bolts, but do not tighten. Check all tubes for correct alignment and that none are pinched or bent. The clamp bolts can now be tightened.

MAIN BOOM INSTALLATION

Attach the inner end of the main boom to the swivel bracket with the cylinder anchors mounting upward, and at a right angle to the tractor. Secure it with the horizontal hinge pin. Secure the hinge pin in the boss with capscrews, etc. (see parts section).

Attach the butt end of the main boom cylinder to the swivel bracket anchor with the special "bracket head" cylinder pin and roll pin shown in parts section.

Install the travelock on the rod end of the main boom cylinder. This should be facing the butt end of the cylinder after installation.

Install the fittings and hoses to the main boom cylinder.

GREASE HINGE PIN ZERKS ON BOOM AFTER ASSEMBLY, ONCE UNDER LOAD WITH BOOM ELEVATED AND AGAIN AT REST WITH BOOM SUPPORTED.

ASSEMBLY

NOTE ON HUSCO CONTROL VALVES

Manual, cable controlled (Husco control valve) boom mowers require check valves with integral restricting orifice (#06502036) installed in the control valve work ports that are connected to the gland ends of the main and secondary boom cylinders. This check valve allows oil to free flow into the gland end of the main and secondary boom cylinders, but restricts flow out of the cylinder, thereby providing proper boom control. This check valve, #06502036 is similar in appearance to hose adapter #33271. These components can be identified as follows, and are to be installed per parts section for the lift valve.

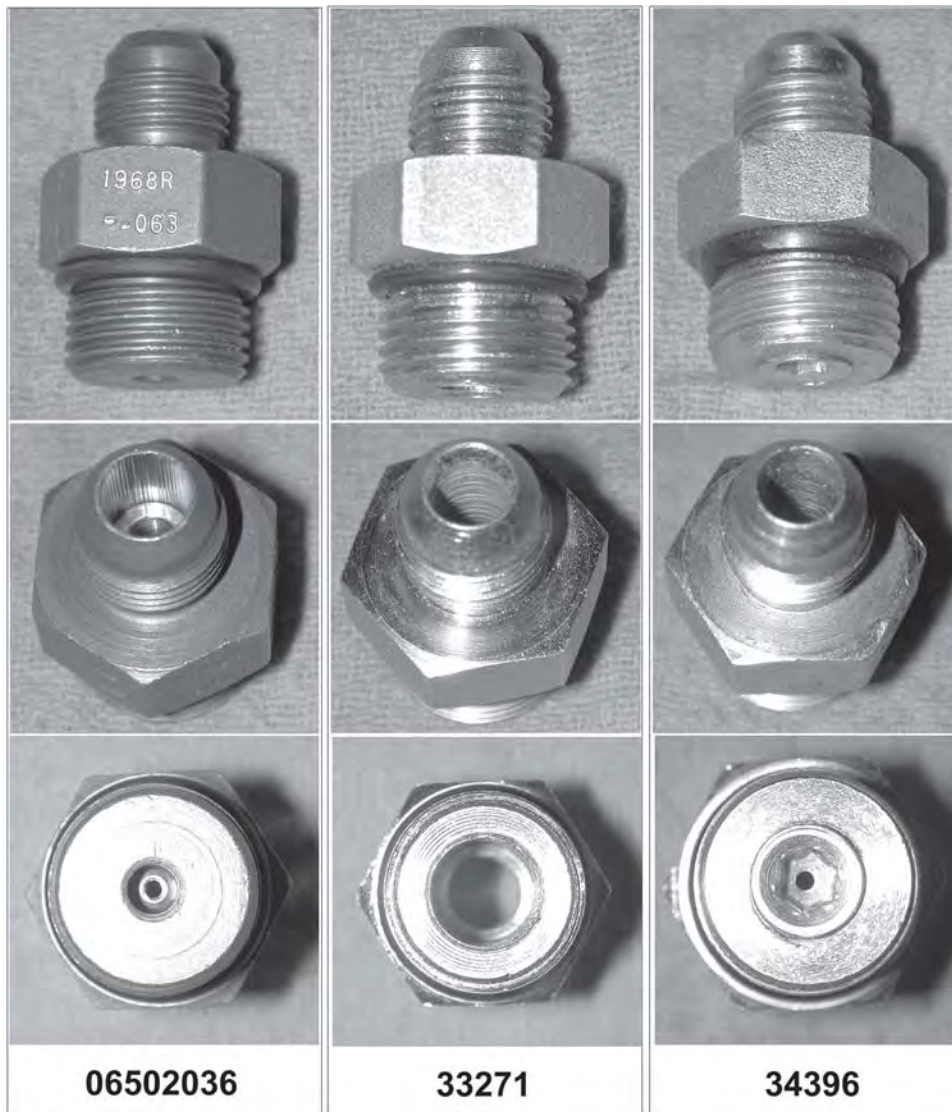

ASSEMBLY

ACCUMULATOR INSTALLATION / PLUMBING

Install the accumulator bracket on top of the main frame mast with the capscrews and lockwashers shown. Install the accumulator in the bracket and secure with the hardware shown. Install the tee on the accumulator and the hose from the accumulator to the travel lock valve on the main boom cylinder. Install hose from accumulator to the control valve.

DITCHER HEAD MOUNTING

If not mounting a ditcher head, go to the deck attachment step.

Align the main boom at a right angle to the tractor, then raise up higher than the ditcher head. Slide the ditcher head into place under the main boom. Lower the main boom and align the bosses on the main boom and ditcher head, then insert the pin from the left (facing tractor). Secure with capscrews, etc.

When ditcher head is secure, find the cylinder with the tang and clevis and install the O-ring adapter in the butt end as shown below. The swivel should be toward the rod end of the cylinder.

Install the non-swivel O-ring adapter with female pipe thread end in the rod end of the outer boom cylinder. Install the restrictor, also provided, into the adapter, again, using teflon tape.

ASSEMBLY

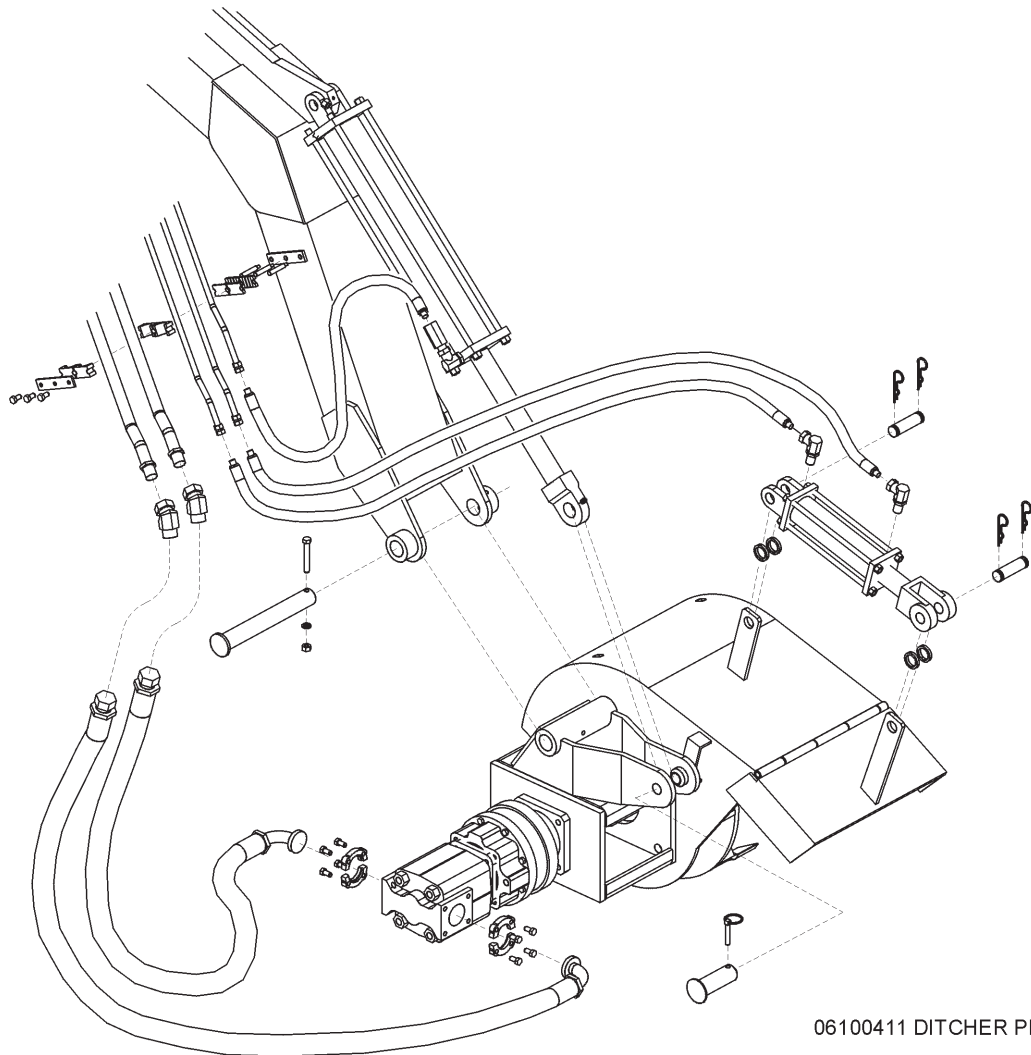

06100411 DITCHER PIVOT

Place the cylinder on top of the main boom and secure the butt end clevis to the cylinder anchor with the cylinder pin and two roll pins. Secure the tank clevis between the ditcher head ears with the tapered cap pin (anodized finish) and lynch pin. Be sure zerk hole in tang clevis is pointing upward and fittings are on the left side of the boom assembly (facing tractor). Tighten tang clevis to the cylinder rod. Tighten the set screw. See parts section for illustration.

Find the small cylinder and install the fittings on both ends. The fittings should face the butt end of the cylinder. Place the cylinder with the butt end on the bonnet of the ditcher head and rod clevis on deflector chute. The fittings should be up. On standard rotation, the rod should point away from the tractor, reversed rotation should point toward the tractor. Secure the cylinder into place with spacers, pins and hairpin clips. Connect all hoses from the cylinders to the small preformed tubes, paying close attention to the connection from the controls to the valve to the cylinder

Connect fittings and hoses as shown from the motor to the large preformed tubes on the boom.

ASSEMBLY

DECK ATTACHMENT

Attach the head to the secondary boom using the pins and hardware shown in the parts section. Install the deck pivot cylinder using the pins and hardware also shown in the parts section.

Connect the fittings and hoses from the pivot cylinder to the small preformed tubes on the boom arm. Connect the fittings and hoses from the motor to the large preformed tubes on the boom arm.

Connect all remaining hoses from the control valve to the cylinders and / or preformed tubes on the boom arm. Refer to parts section for diagrams.

HOSE COVERING

Secure hoses together with zip ties wherever loose. Wrap the hoses between the main boom and secondary boom with the yellow hose cover, secure with black string provided. Where hoses may contact the frame or other edges, wrap with split hose and secure with hose clamps or zip ties. On non cab units the pressure and return hoses from the control valve will also need to be routed inside the protective clear hose wrap. Cover the valve, valve fittings with the yellow hose cover and secure with black string provided.

Before proceeding to the final preparation step double check the complete assembly from the main frame to the cutter head against the diagrams in the parts section for proper placement and assembly of all components.

ASSEMBLY

BOOM JOYSTICK CONTROL CALIBRATION

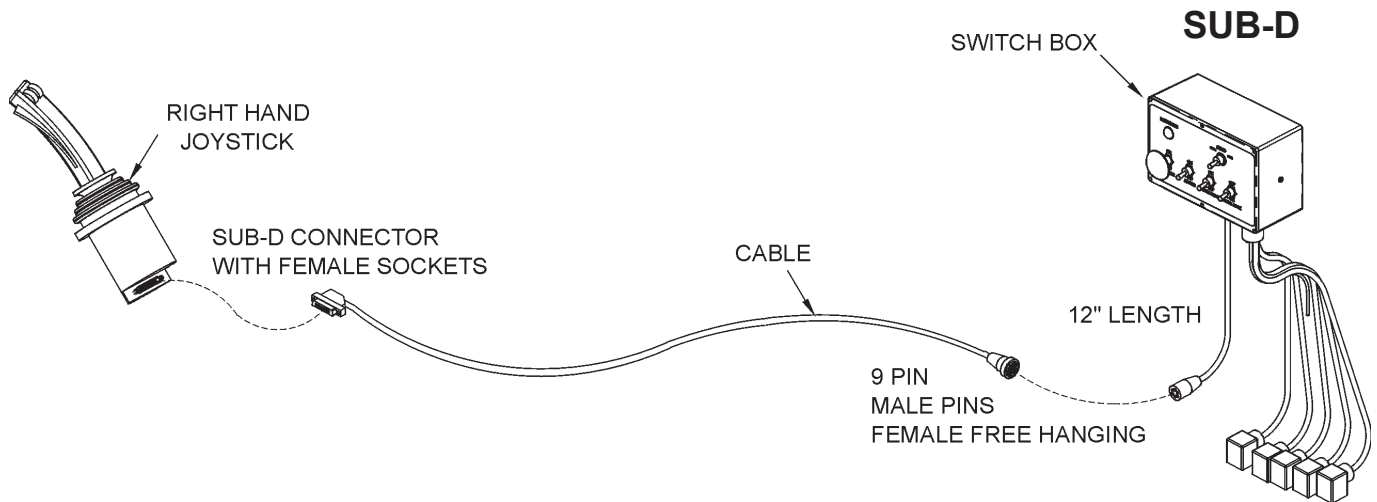

This Danfoss PVG32 control valve is now equipped with higher-resolution actuators on Main Boom, Secondary Boom, Deck Roll, and Swivel functions. These actuators have “active fault monitoring”. The Deck Shield section does not have “active fault monitoring”. The joystick is unchanged and provides a ratio-metric voltage signal. The neutral signal voltage is half or 50% of tractor supply voltage. A 25% signal voltage will shift the valve spool to full “A-Port”, and 75% signal voltage will shift the spool to full “B-Port” in the Main, Secondary, and Swivel valve sections. On the Deck Roll function a 34% signal voltage will shift the valve spool to full “A-Port” and a 68% signal voltage will shift the spool to full “B-port”. If an actuator with active fault monitoring receives a signal from the joystick that is less than 15% or greater than 85% of supply voltage the actuator will “fault out” and shut down. Also if there is an internal failure in the actuator or if the spool position is greater than that specified by the signal voltage from the joystick, the actuator will “fault out” and shut down. An “active fault” condition causes the actuator to drive the spool to neutral, shut down, and activate a “red” LED on the top of the actuator. The active fault can be canceled by simply cycling the Master Switch “OFF” and then “ON”, which resets the fault monitoring, and causes the LED on top of the actuator be “green” again.

CAUTION!



The joystick control is equipped with signal adaption potentiometers.

These provide the capability to individually adjust the oil flow to each boom function. It is important that the boom functions do not travel too fast. Excessive boom speed can reduce the stability of the unit and decrease operator control.

Note: Use a Phillips screw driver and be sure to adjust the screws carefully! DO NOT turn the potentiometers beyond their stopping point, potentiometers are very delicate! Turning the “A” or “B” port potentiometers clockwise increases the oil flow to increase the boom function speed, and turning them counterclockwise decreases the oil flow to decrease the boom function speed. See the graphic on the next few pages for help in adjusting.

ASSEMBLY

Run tractor at normal operating RPM to adjust the settings as follows.

Set the dead band compensation potentiometer first.

Set the dead band compensation potentiometer at 50%, or halfway between full clockwise and full counter-clockwise.

Setting Signal Adaptation Potentiometers:

Disconnect the Deutsch connectors from the actuators of the valve. Use a Volt/Ohm meter to measure signal voltage and adjust the signal adaptation potentiometers as needed. Pin #4 is tractor supply voltage. Pin #1 is signal voltage from the joystick, and pin #3 is ground. First measure supply voltage between pins 4 and 3. Then measure signal voltage between pins 1 and 3 while indexing the joystick function fully in both the "A" and "B" port direction. Divide the signal voltage by the supply voltage to get signal voltage as a % of supply voltage. This percentage should not be less than 25% or greater than 75% for the Main Boom, Secondary Boom, or Swivel function. This percentage should not be less than 30% or greater than 62% for the Deck Roll function. Note these initial settings for the Deck Roll function should prevent the spool from shifting into float. *After making this first adjustment to deck roll if the spool still goes into float, adjust the "B" port screw additionally counterclockwise.*

Reconnect Deutsch connectors on control cables to actuators on Danfoss valve. Run tractor until hydraulic system is at operating temperature. Now refine the adjustments of the signal adaptation potentiometers for both "A" and "B" ports for all proportional functions to achieve the following function times. Note: turning potentiometer clockwise increases the flow or the function speed, and turning them counter-clockwise decreases the flow or the function speed. Note, if during this procedure the trim potentiometer is set to full "counterclockwise" but the function is still too fast, use the mechanical stops at the manual actuator end of the valve section to further limit flow. Turn limit screw in or clockwise to limit flow. The upper limit screw limits flow to "B-port", and the lower limit screw limits flow to "A-port". However DO NOT adjust the limit screw on "B-port" of deck roll function. Limiting "B-port" will prevent "float" function.

ASSEMBLY

MAIN BOOM: “A” Port, Boom UP: 7-9 Seconds

(Note: Extend secondary boom completely; roll deck to be level with ground, and lower main boom until deck is on ground. Now index main boom “up” function and determine the time required for main boom to rise completely.)

“B” Port, Boom Down: 6-8 Seconds

(Note: Extend secondary boom completely, roll deck to be level with ground, and raise the main boom to “full up”. Then index the main boom “down” function to determine the amount of time required for the deck to contact the ground. CAUTION: Stop the boom just as the deck contacts the ground.)

SECONDARY

BOOM: “A” Port, Boom Out: 8-10 Seconds

(Position main boom full up, roll deck out until deck cylinder is fully retracted, and bring secondary boom in completely. Then index the secondary boom “out” function and determine the time required for boom to extend out completely.)

“B” Port, Boom In: 8-10 Seconds

(Position the main boom full up, roll deck out until deck cylinder is fully retracted, and extend secondary boom completely. Then index the secondary boom “in” function and determine the time required for boom to come in.)

DECK ROLL: “A” Port, Deck Out: 5-6 Seconds

(Raise main boom to vertical, extend secondary boom out slightly so that deck can be articulated without contacting the main boom, and roll deck in until deck cylinder is completely extended. Then index the deck roll “out” function and determine the time required for the deck to roll out.)

“B” Port, Deck In: Target 5-6 Seconds (but DO NOT use Limit Screw)

(Raise main boom to vertical, extend secondary boom out slightly so that deck can be articulated without contacting the main boom, and roll deck out until deck cylinder is completely retracted. Then index the deck roll “in” function and determine the time required for the deck to roll in.)

BOOM

SWIVEL: “A” Port, Boom Aft: 6-8 Seconds

(Extend booms completely; rotate head to be level with ground, lower main boom until deck is just above ground, and swivel boom full forward. Then index the boom swivel “aft” function and determine the time required for the boom to swivel full aft.)

“B” Port, Boom Forward: 6-8 Seconds

(Extend booms completely, rotate head to be level with ground, lower main boom until deck is just above ground, and swivel boom full aft. Then index the boom swivel “forward” function and determine the time required for the boom to swivel full forward.)

ASSEMBLY

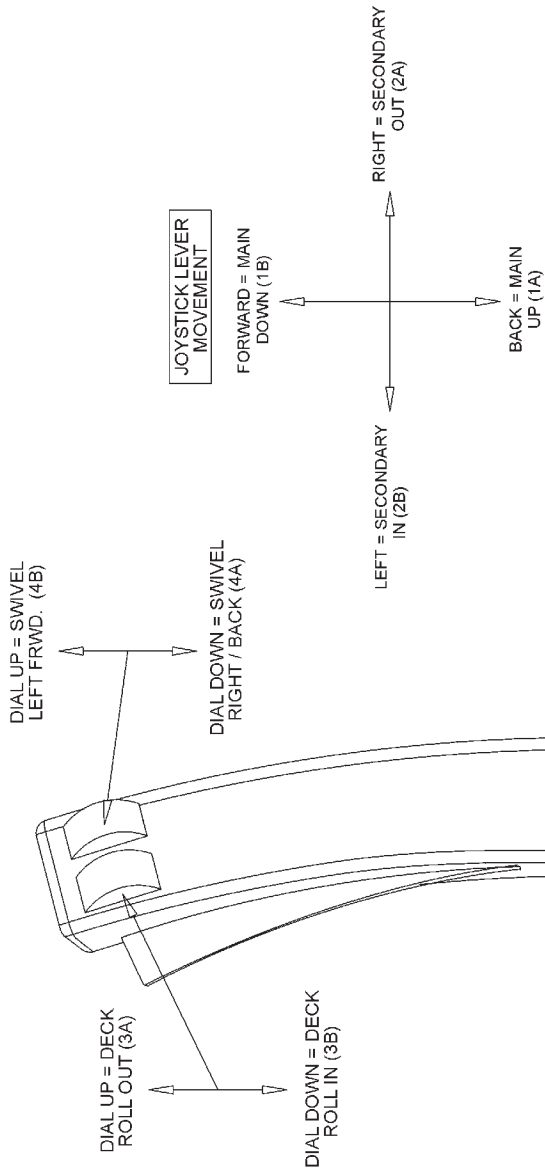
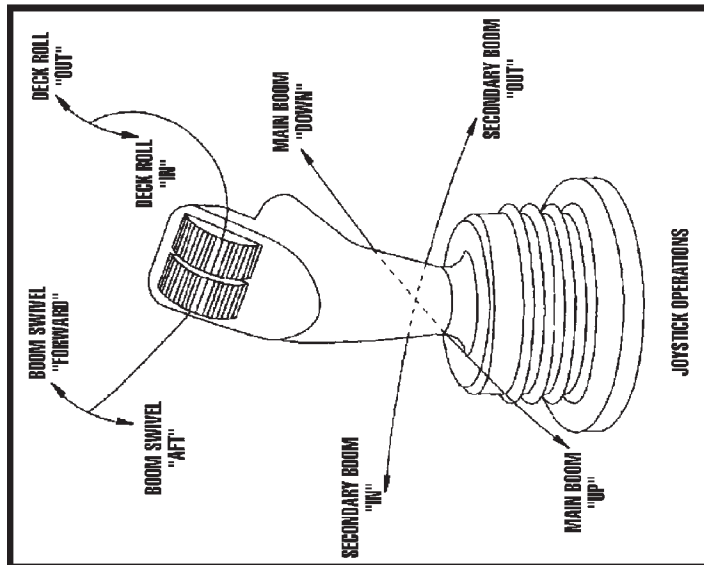

SIGNAL ADAPTION POTENTIOMETERS

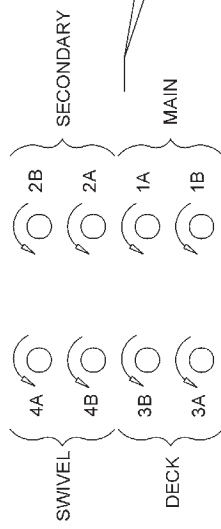

○ — DEAD BAND COMPENSATION
 NOTE: FULL C-CLOCKWISE RESULTS IN MAXIMUM "DEAD BAND"

ARROW DIRECTION () DENOTES DIRECTION TO DECREASE OIL FLOW (SLOW BOOM FUNCTIONS)

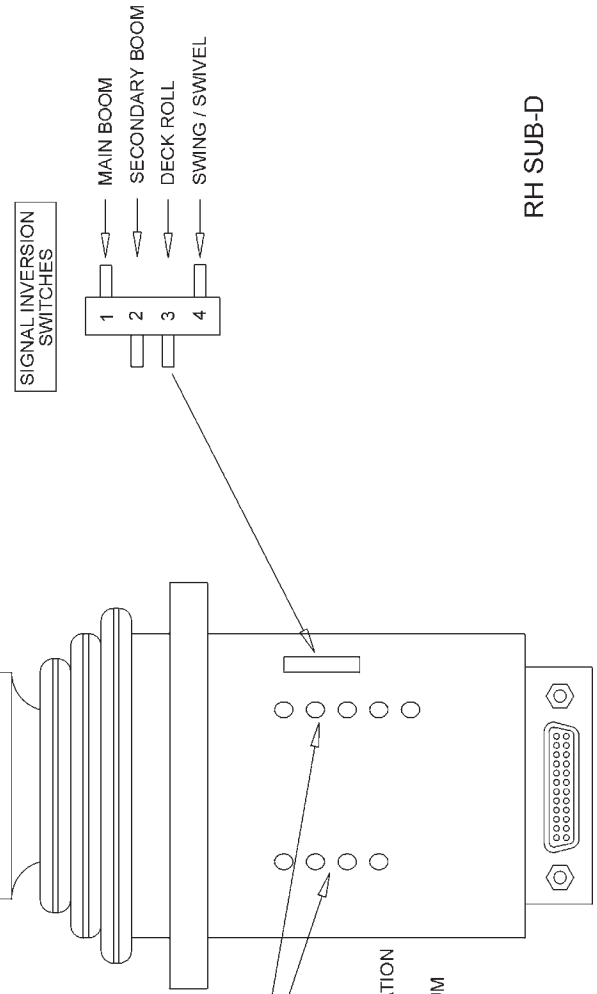

ASSEMBLY

FINAL PREPARATION FOR OPERATION

Place operators safety and operation decals on the steering column and side counsel where they are clearly visible to the operator. These decals should be understood by each operator of the machine in conjunction with the safety and operation section of this book. The decals are to remain in good condition as a reminder to the operator, and should be replaced if damaged.

Finally, all bosses, pins and pivot points will need to be greased as instructed in the maintenance section of this manual. The hydraulic reservoir can also be filled with the recommended fluid (see maintenance section) and the filter installed in the top of the tank. Double check all fittings and fasteners BEFORE starting tractor. Also secure any loose hoses together with zip ties and wrap with split hoses where friction may occur on the hoses.

WARNING!



BEFORE starting or operating the tractor you must read and understand the safety and operation sections of this manual completely.

BE SURE THE BALL VALVES ARE OPEN! Start tractor and allow instruments to stabilize. Using a piece of paper or cardboard as noted in the safety and maintenance sections, check all fittings and connections for hydraulic leaks.

If a leak is found, you must shut down the tractor, set the cutter on the ground. Before attempting to fix the leak, you must actuate the lift valve handles several times to relieve any pressure in the lines.

Before operating the mower, the cutter head and boom should be slowly moved throughout the full range of motion. Watch for any condition that would cause pinching or excess stress on the hoses. The steering and front axle travel should also be carefully moved through their full range of motion. If any condition occurs in which the hoses contact the tires, the steering and / or front axle travel may need to be limited as described in the tractor operators manual. This should also be done if the tires rub, or are extremely close to any other part of the mower such as the hydraulic tank or draft beam. This may include adding shims, or adjusting stop bolts in the tractor front to solve the problem. While checking motion, you should also check that the control circuits are connected according to the operators decal for the valve handles.

MOWER TESTING

Take the tractor to a place free of loose objects on the ground. Operate the cylinders through their full range of motion again, to clear the lines of air. Follow the instructions in the operation section to operate the mower. Vibration of the mower should be minimal at all times. After a 5 minute test run, the knife bolts should be retorqued and once again after the first few hours of operation.

If any parts of this assembly section, or any other section of this manual are not clearly understood you must contact your dealer or the address on the front of this manual for assistance!

ASSEMBLY

OPERATION SECTION

OPERATION

Safety is of primary importance to the owner / operator and to the manufacturer . The first section of this manual includes a list of Safety Messages, that, if followed, will help protect the operator and bystanders from injury or death. Many of the messages will be repeated throughout the manual. The owner / operator / dealer should know these Safety Messages before assembly and be aware of the hazards of operating this mower during assembly, use, and maintenance.

The **Safety Alert Symbol** combined with a signal word, as seen below, is intended to warn the owner / operator of impending hazards and the degree of injury possible during operation.

DANGER!



Indicates an imminently hazardous situation that, if not avoided, **WILL** result in DEATH OR VERY SERIOUS INJURY.

WARNING!



Indicates an imminently hazardous situation that, if not avoided, **COULD** result in DEATH OR SERIOUS INJURY.

CAUTION!



Indicates an imminently hazardous situation that, if not avoided, **MAY** result in MINOR INJURY.

IMPORTANT!

Identifies special instructions or procedures that, if not strictly observed, could result in damage to, or destruction of the machine, attachments or the environment.

NOTE: *Identifies points of particular interest for more efficient or convenient operation or repair.* (SG-1)

WARNING!



Many varied objects, such as wire, cable, rope, or chains, can become entangled in the operating parts of the mower head. These items could then swing outside the housing at greater velocities than the blades. Such a situation is extremely hazardous and could result in serious injury or even death. Inspect the cutting area for such objects before mowing. Remove any like object from the site. Never allow the cutting blades to contact such items. (SGM-6)

OPERATION

CAUTION!



Before any operation of tractor and mower, the user should read and understand the safety and operating instructions for both the tractor and the mower. The user should also be familiar with the location and functions of the units instruments and controls. Being familiar with the machine and it's controls will increase efficiency and reduce possibility of serious injury or damage to the unit. The operator should work slowly and carefully until he feels comfortable with the machine. Speed and skill will be attained much easier if the necessary time is spent to familiarize yourself with the machine and its operations.

Since tractor makes and models vary, we recommend reading and following the operators manual provided by the manufacturer pertaining to your particular unit.

WARNING!



Extreme care should be taken when operating near loose objects such as gravel, rocks, wire, and other debris. Inspect the area before mowing. Foreign objects should be removed from the site to prevent machine damage and/or bodily injury or even death. Any objects that cannot be removed must be clearly marked and carefully avoided by the operator. Stop mowing immediately if blades strike a foreign object. Repair all damage and make certain rotor or blade carrier is balanced before resuming mowing.^(SGM-5)



STARTING TRACTOR AND MOWER

Check the operators manual received from the tractor manufacturer, for their recommendation and procedures pertaining to your particular make and model.

WARNING!



When rotating parts are in motion, serious injury may occur if caution is not used or danger is not recognized. Never allow bystanders within **300 feet** of the machine when mower is in operation.



Be sure the ball valves on the mower hydraulic tank are **OPEN** before starting the tractor. Serious damage to the hydraulic system can occur if the valves are not open.

WARNING!



Check to make sure mower switch is in the "**OFF**" position. The unit is designed not to start if the switch is in the "on" position. If tractor starts with switch on, turn off tractor and contact your local Tiger dealership for assistance.

OPERATION

Start the tractor and allow the instruments to stabilize. Without starting the mower, practice positioning the boom and deck. Remember, speed and skill will be attained easier if the necessary time is spent familiarizing yourself with the machine and its operations. When you feel comfortable at controlling the position of the mower, return the mower to the travel position, and transport the mower to the desired mowing location.

If mowing for the first time with a Tiger Boom Mower, we recommend choosing a ditch or area relatively flat with a minimum of sign posts, guard rails, etc. As always, you should inspect the area for other objects that can cause potential hazards and removing them before mowing.

The Mower Control switch turns the mower “ON” and “OFF. This switch is to be in the “OFF” position to start the tractor. If the switch is “ON” and the tractor ignition switch is turned to “ON” the red “mower run” indicator light will come on. However, the tractor will not start with the Mower Control switch in the “ON” position. Upon starting tractor the “mower run” indicator light may flash briefly, and may flash briefly again when tractor is shut down.

WARNING!



If tractor starts with switch on, turn off tractor and contact your local Tiger dealership for assistance.

NOTE: The tractor ignition switch and the Master Switch must be “ON” ” to allow movement of the mower deck.

SWITCHBOX



OPERATION

The Safety Shield lever opens and closes the shield located on the front of the cutter head. When mowing at or near the ground, always have the shield in the closed position. When mowing in brush or in trees above ground level the shield may be opened for easier cutting. Read and follow the warnings on the decal shown below. **Do not run the cutter head into material larger than 6" diameter .**



SAFETY SHIELD OPERATION

- **Failure to close Safety Shield may allow objects to be thrown outward with great force which can cause property damage, bodily injury, or death.**
1. **Keep Safety Shield fully closed when cutting grass and weeds to reduce possibility of objects being thrown outward by the Blades and to prevent contact with the Blades if persons are in the area.**
 2. **Before cutting brush, trimming limbs, or other such operations, raise Safety Shield fully to allow the blades to contact the material if area is clear of passersby. Operator must stop cutting and close shield if passerby enters the thrown objects area or blade contact area.**
 3. **Repair or replace Safety Shield as needed.**
 4. **Always transport with Safety Shield closed.**

OPERATION

CABLE CONTROLLED MOWERS

A control lever decal similar to the one shown below should be near the control valve to remind the operator of the lever functions.

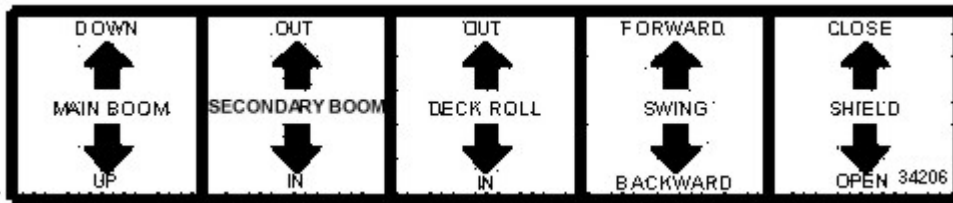

The main control valve on the Tiger Boom Mower has five sections with tapered spools, located near the right side of the steering wheel. The malfunction of a section of the valve does not necessitate the replacement of the entire “bank”, only the faulty section. Each section of the valve controls a certain position of the boom or deck. Seated in the operators seat, the controls from left to right are #1 - primary(main) boom, #2 – secondary boom, #3 – deck roll, #4 – boom (swivel)swing, and #5 boom(safety) shield.



OPERATION

LEVER #1 MAIN BOOM

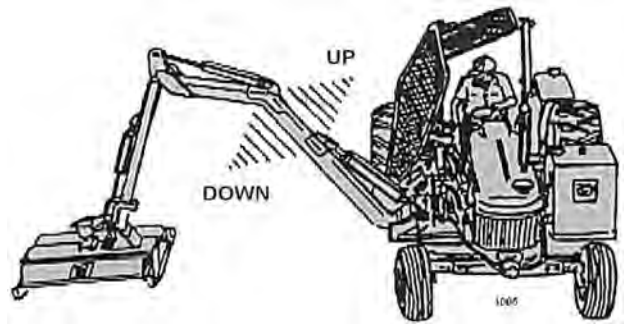

LEVER #2 SECONDARY BOOM

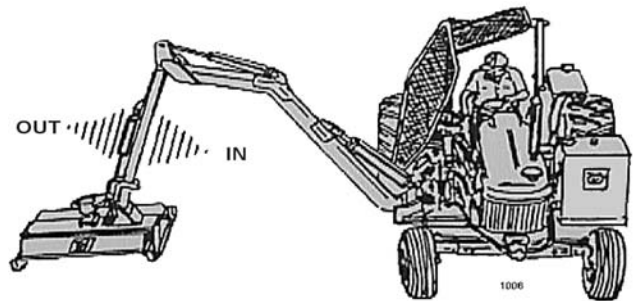

LEVER #3 DECK ROLL

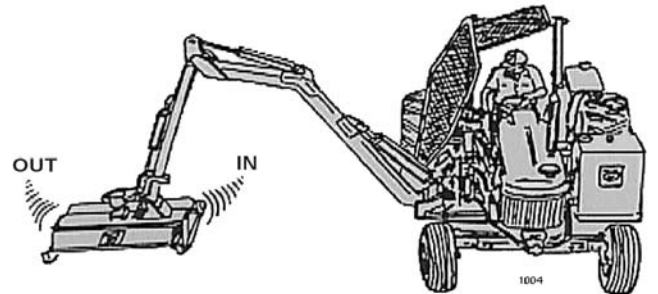

LEVER #4 BOOM SWIVEL

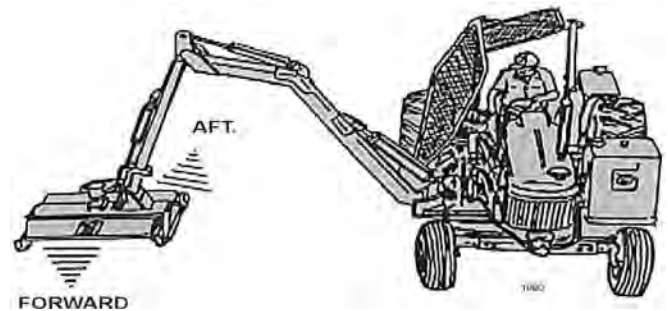

LEVER #5 BOOM SHIELD

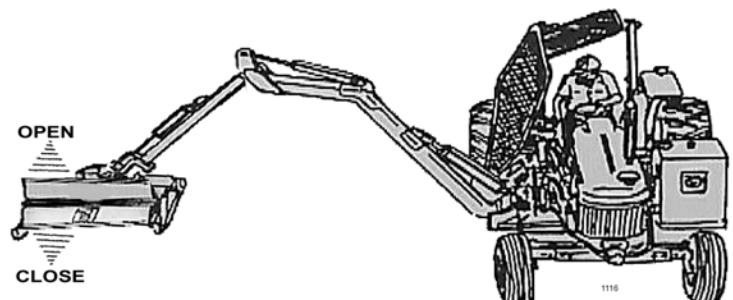

OPERATION

DANFOSS JOYSTICK CONTROLLED MOWERS

WARNING!



NOTE: **DO NOT** operate mower head while boom mower is in the boom rest, or in the stored position! Red “Mower Run” light indicates mower is “ON”.

The boom functions are controlled by an electronic joystick. The Joystick Master Switch enables the joystick control for controlling the boom motion functions. This switch is to be in the “OFF” position when starting the tractor and when boom is stowed for transporting the machine.

CAUTION!



If the joystick control is not operating properly, turn the master switch to the “OFF” position. Install the manual valve handle onto valve and operate the functions individually to stow boom. After boom is stowed in rest, transport the unit to the maintenance facility and contact your Tiger dealer for assistance.

CAUTION!



DO NOT attempt to operate the valve manually for mowing operations!

Note: Pushing manual valve handles “out” or “away” from the tractor cab will bring the main boom “up”, secondary boom “out”, roll deck “out”, and swivel boom “aft”. Pulling manual handles toward cab will let main boom “down”, bring secondary boom “in”, roll deck “in”, and swivel boom “forward”.

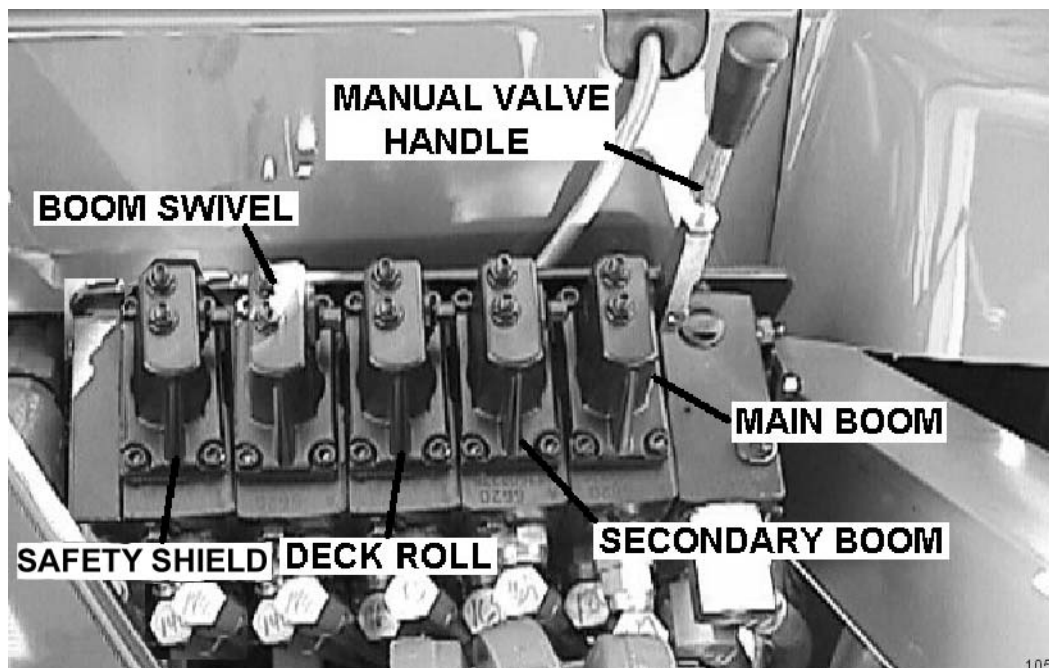

OPERATION

DANFOSS SWITCH BOX AND JOYSTICK CONTROL

The diagrams below and on the next page show the functions that are performed through the use of the joystick controller.

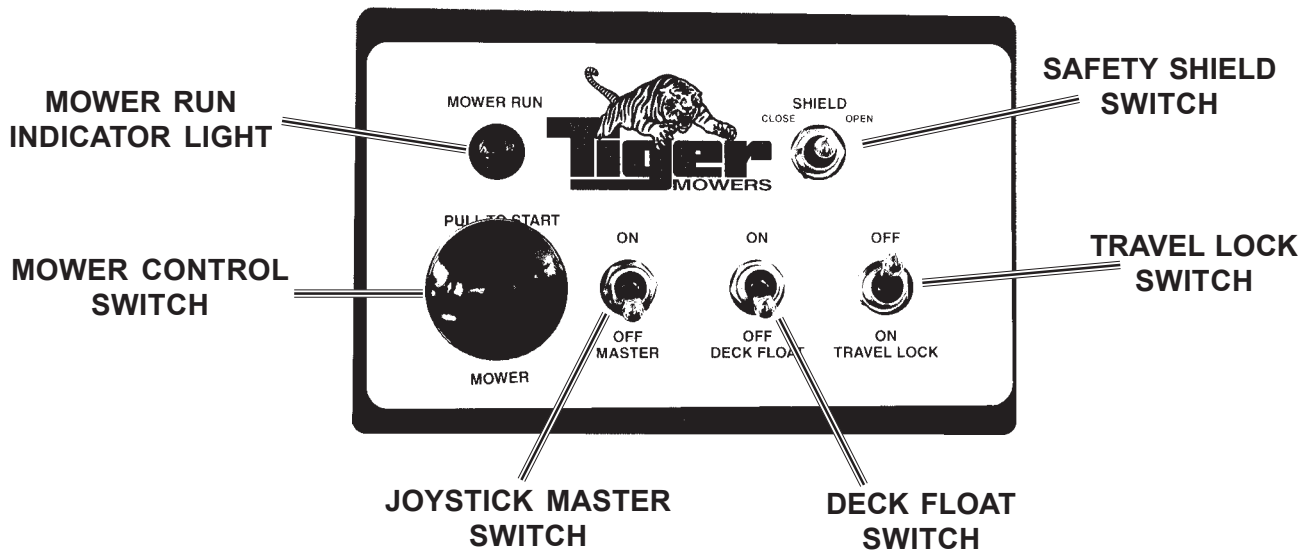

The Safety Shield switch opens and closes the shield located on the front of the cutter head. When mowing at or near the ground, always have the shield in the closed position. When mowing in brush or in trees above ground level the shield may be opened for easier cutting. Read and follow the warnings on the decal shown below. **Do not run the cutter head into material larger than 6" diameter .**

DANGER

SAFETY SHIELD OPERATION

- Failure to close Safety Shield may allow objects to be thrown outward with great force which can cause property damage, bodily injury, or death.
1. Keep Safety Shield fully closed when cutting grass and weeds to reduce possibility of objects being thrown outward by the Blades and to prevent contact with the Blades if persons are in the area.
 2. Before cutting brush, trimming limbs, or other such operations, raise Safety Shield fully to allow the blades to contact the material if area is clear of passersby. Operator must stop cutting and close shield if passerby enters the thrown objects area or blade contact area.
 3. Repair or replace Safety Shield as needed.
 4. Always transport with Safety Shield closed.

OPERATION

JOYSTICK CONTROL

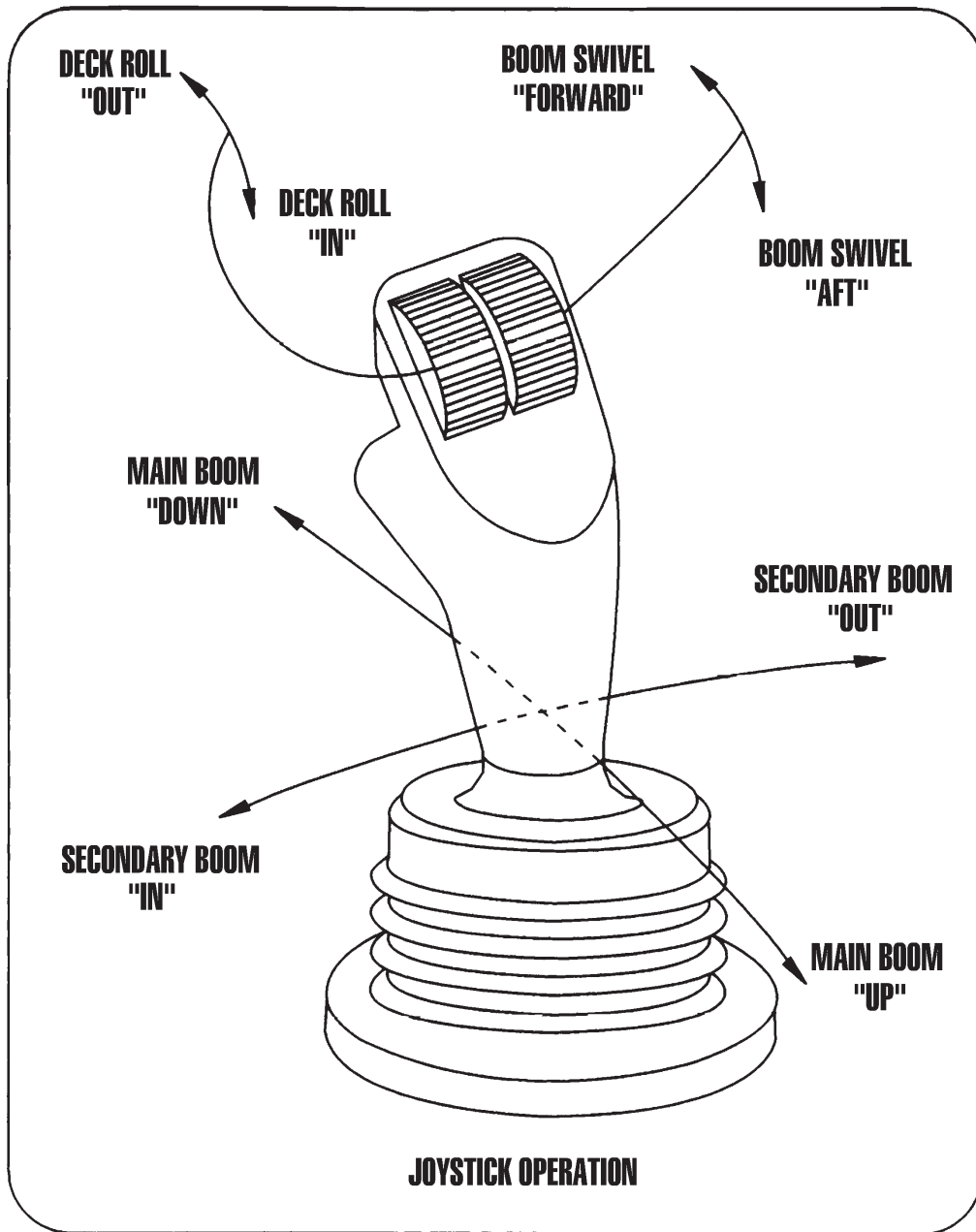

1057

OPERATION

**JOYSTICK FWD / BACK
MOVES MAIN BOOM**

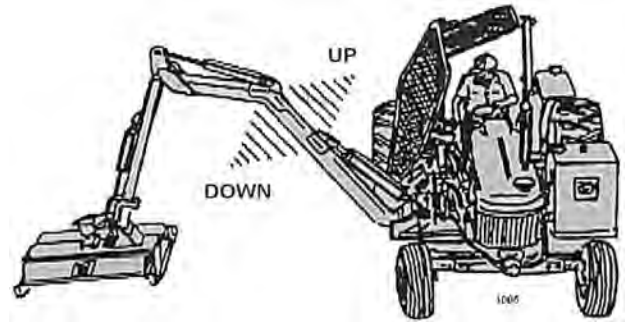

**JOYSTICK LEFT / RIGHT
MOVES SECONDARY BOOM**

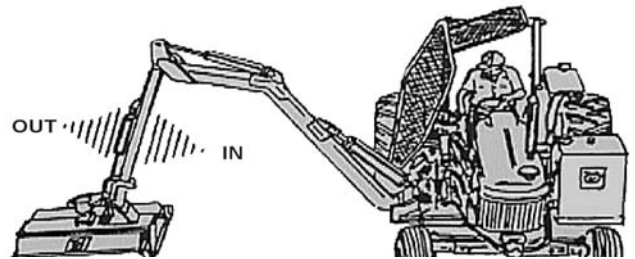

**LEFT JOYSTICK ROLLER
MOVES DECK ROLL**

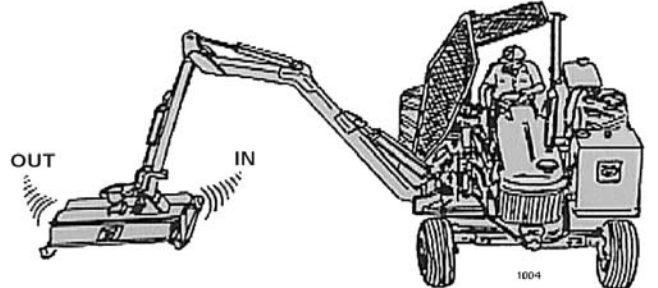

**RIGHT JOYSTICK ROLLER
MOVES BOOM SWIVEL**

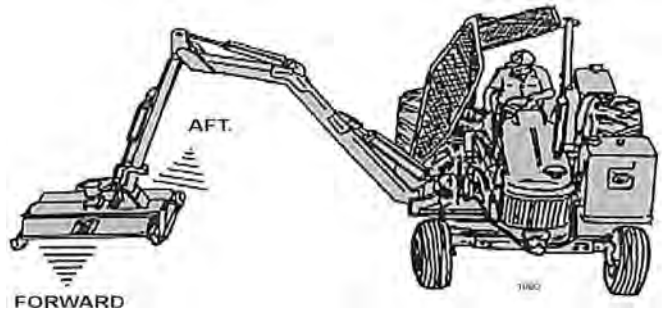

**SHIELD SWITCH
(ON SWITCH BOX)
OPERATES SAFETY
SHIELD**

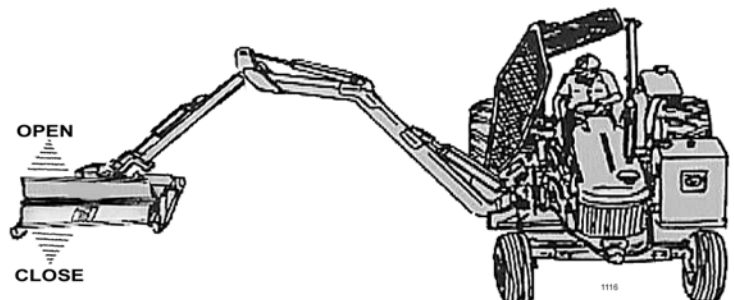

OPERATION

MOWER OPERATION

WARNING!



When rotating parts are in motion, serious injury may occur if caution is not used or danger is not recognized. Never allow bystanders within **300 feet** of the machine when in operation. Extreme care should be taken when operating near loose objects – such as gravel, rocks and debris. These conditions should be avoided.

The rotating parts in this machine have been designed and tested for rugged use. However, they could fail upon impact with heavy solid objects – such as steel guard rails, concrete abutments, etc., causing them to be thrown at a very high velocity. Never allow cutter head to contact such objects. Inspecting the cutting area for such objects and removing them prior to mowing can help eliminate these potential hazards.

Once on location, lower the mower deck slightly above the material to be cut, so the mower does not have to start under a load. With the tractor at an idle, engage mower. Bring tractor R.P.M. up to 1900 – 2200 R.P.M. and **slowly** lower deck to ground level.

A flail mower deck should be carried so that part of the deck weight is carried by the boom and part carried by the ground roller, when mowing on the ground. When the flail mower is carried this way, the ground roller follows the contour of the ground more easily during mowing operations.

The rotary mower deck should always be carried rather than dragged on the skid shoes when mowing on the ground. Dragging the rotary mower deck increases the side loads on the boom, decreases the horsepower available to the cutter head, and reduces the ability of the accumulator to carry part of the weight of the boom during mowing operations.

50” BOOM ROTARY

The 50” boom rotary mower was designed for cutting brush and foliage up to 6 inches in diameter or multiple branches that have a total cross section area equivalent to one 6 inch branch.

During mower operation, the hand throttle must be used to maintain engine speed at 1900 – 2200 R.P.M. This prevents radical changes in mower spindle speeds, reducing the possibility of cutter assembly damage.

The horizontal positioning action of the boom is designed to position the cutting head and provide a limited pressure relief when excessive pressure is applied to the boom. Do not force the cutting head into heavy branches or stumps. Damage to the unit may result.

CAUTION!



When using the rotary cutting head for trimming trees and shrubs, let the mower saw into them. Do not lower the mower head down directly onto a tree or stump. The mower blades are designed to cut with the end, and misuse can cause damage to the blade and a hazardous situation for the operator.

OPERATION

CAUTION!



Powering the boom down, forcing mower deck onto ground may damage mower deck and it's attachment to the boom, creating a potentially hazardous situation.

To ensure a clean cut, engine speed should be maintained at approximately 1900 – 2200 R.P.M. If the tractor slows to less than 1800 R.P.M., shift to the next lower gear. **DO NOT** ride the clutch, this will cause premature clutch failure. **The engine should not be operated at any time at more than 2400 R.P.M. on the tractor tachometer.**

For cutting brush it is usually best to stop the tractor and swivel the boom and mower into foliage. The horizontal positioning action of the boom is designed to position the cutting head and provide a limited pressure relief when excessive pressure is applied to the boom.

CAUTION!



DO NOT use excessive force when positioning cutting head into heavy branches or stumps. Damage to the unit may result. It is best to let the cutter head “eat away” slowly at heavy cutting jobs.

CAUTION!



If foliage falls on top of mower deck causing tractor to become unstable, move the boom “Forward” and “Out” to relieve tipping of the tractor. Lower mower deck to ground and shut down unit. After all motion stops, remove foliage from mower deck.

The mower will operate more efficiently in tougher conditions and with less power if the knives are kept sharp. If the mower begins to vibrate, stop the tractor, check for wire wrapped in the spindle or damaged knives. When replacing knives, replace all knives with new knives to ensure proper balance so the mower will not vibrate. Severe vibration will result, if knives with unequal wear are used.

Begin a pass at the top side of the trees and work down with each consecutive pass. When cutting trees and shrubs, use a lower speed to allow the knives time to cut as well as mulch the foliage.

WARNING!



If bystanders approach within 300 feet while mower is in operation turn mower switch “OFF” immediately! After shutdown, never leave the tractor or allow bystanders to approach within **300 FEET** of the unit until all motion stops completely.

If cutter shaft jams and stops, turn mower switch to “OFF”, and swivel boom “AFT”. Normally this action will clear the cutter head. If not, roll mower deck until adjacent to the secondary boom, then lower boom to rest mower deck on ground. Shut off the tractor, set parking break, allow all motion to cease. At that point it is safe to leave the tractor and clear the cutter heads manually.

Begin each pass at the top side of the trees and work down with each consecutive pass. Use a low speed to allow the cutting blades time to mulch as well as cut the foliage. When the initial pass has been made, disengage the mower, and return boom to a safe travel position. Return to starting point and make next pass, etc..

OPERATION

After the first day of operation, all bolts should be checked and tightened securely. This should be done periodically to ensure the bolts do not become loose and cause damage to the tractor or mower, or injury to the operator.

50" BOOM FLAIL

The 50" boom flail mower was designed for cutting brush and foliage up to 2 inches in diameter or multiple branches that have a total cross section area equivalent to one 2 inch branch. Cutting multiple limbs at the same time may overload the mower causing it to slow down or stop completely. Regardless of the size of material being cut, the cutter shaft speed must be maintained. To ensure that the cutter shaft is running at maximum speed, run the tractor at full throttle during mowing operations. If the cutter shaft slows to the point that the knives are folding back, move the mower head away from the foliage and allow the cutter shaft to regain full speed.

WARNING!



Operating the mower in a manner that allows the knives to continually fold back or allowing knife lugs to contact foliage will cause permanent damage to the cutter shaft drum, knives, and knife attachment parts.

WARNING!



The 50" boom flail cutter shaft is designed for standard rotation (same rotation as the tractor wheels during forward travel). **Never operate the cutter shaft in reverse rotation.** Operating this mower in reverse rotation may cause objects to be thrown out the front of the mower head.

WARNING!



The 50" boom flail equipped with free swinging brush knives is intended for brush cutting only. Cutting grass is not recommended.

WARNING!



Do not allow knives to cut down to the ground. Position ground roller to maintain knife arc at a minimum of 2 inches above the ground. Knife contact or lug contact with ground will cause permanent damage to cutter shaft, knives, and knife attachment parts.

63" BOOM FLAIL

The 63" boom flail mower was designed for cutting grass. The cutter shaft speed must be maintained for proper cutting. To insure that the cutter shaft is rotating at maximum speed, run tractor at full throttle during mowing operations. If cutter shaft slows to the point that the knives are folding back against the cutter shaft, move the mower head away from the foliage and allow the cutter shaft to regain full speed.

OPERATION

WARNING!



Operating the mower in a manner that allows the knives to contact the drum will cause permanent damage to the cutter shaft drum, knives, and knife attachment parts.

WARNING!



The 63" boom flail cutter shaft is designed for standard rotation (same rotation as the tractor wheels during forward travel). **Never operate the cutter shaft in reverse rotation.** Operating this mower in reverse rotation may cause objects to be thrown out the front of the mower head.

TRANSPORTING MOWER

Transporting under the units own power:

When transporting between job sites or between cutting passes, the following procedure should be followed: Shut off the power to the cutting head and allow all motion to come to a complete stop. Raise the boom to it's highest position, being cautious of overhead obstructions such as highline wires. Rotate the deck until stop bolt touches secondary boom. Swing boom to a 90 ° angle from tractor. Retract secondary boom until inner skid shoe of the deck just touches the main boom. Check to be sure deck has ample clearance from front and rear tires. The unit is now in position for self transportation.

Transporting unit by flatbed trailer:

Park flatbed on level area. Drive tractor onto center of flatbed to avoid uneven distribution of weight and staying within local width restrictions. If boom is over local height restrictions, you will need to extend booms outward enough to clear front of tractor when boom is pivoted forward. Pivot mower deck to it's extreme outward position and deck cylinder is fully retracted. Lower boom until deck is slightly above trailer bed. Remove cylinder pin from outer end of the boom swivel cylinder.

CAUTION!



CAUTION: If trailer is not perfectly level, the boom will tend to swing towards the lower side. Have other personnel ready to control its swinging motion when cylinder pin is removed.

Retract swivel cylinder and place clear of boom. Pivot boom forward to the center of flat bed. Lower deck onto the trailer bed, and shut off the tractor. The tractor and the mower head should now be chained down securely to the trailer bed.

CAUTION!



If any part of this operating section, or any other section of this manual is not completely understood, contact your Tiger dealer or the address on the cover of this manual for assistance

OPERATION

INSPECTION SHEETS

OPERATION

BOOM MOWER PRE-OPERATION Inspection



Mower ID# _____ Make _____

Date: _____ Shift _____

WARNING!



Before conducting the inspection, make sure the Tractor engine is off, all rotation has stop and the tractor is in the Park with the parking brake engaged. The Mower head is resting on the ground (or is securely blocked up and supported) and all hydraulic pressure has been relieved.

Item	Condition at Start of Shift	Specific Comments if not O.K.
The Operator's Manual is in the Canister on the mower		
All Safety Decals are in place and legible		
The Mounting frame bolts are in place and tight		
The Boom connection bolts & pins are tight		
There are no cracks in boom		
The Hydraulic Cylinders pins are tight		
The Hydraulic Pump hose connections are tight		
The Hydraulic Valve hose connections are tight		
The Hydraulic Valve controls function properly		
There are no leaking or damaged hoses		
The Hydraulic Oil level is full		
There is no evidence of Hydraulic leaks		
The Blades are not chipped, cracked or bent		
The Blade bolts are tight		
The Deflectors are in place and in good condition		
The Mower shields are in place and in good condition		
The Skid shoes are in good condition & tight		
There are no cracks or holes in mower deck		
The Hydraulic motor mounting bolts are tight		
The mower head spindle housing is tight and lubricated		

Operators Signature: _____

DO NOT OPERATE an UNSAFE TRACTOR or MOWER

OPERATION

TRACTOR PRE-OPERATION Inspection



Tractor ID# _____ Make _____

Date: _____ Shift _____

WARNING!



Before conducting the inspection, make sure the Tractor engine is off, all rotation has stop and the tractor is in the Park with the parking brake engaged. The Mower head is resting on the ground (or is securely blocked up and supported) and all hydraulic pressure has been relieved.

Item	Condition at Start of Shift	Specific Comments if not O.K.
The Flashing lights function properly		
The SMV Sign is clean and visible		
The Tires are in good condition with proper pressure		
The Wheel Lug bolts are tight		
The tractor Brakes are in good condition		
The Steering linkage is in good condition		
There are no visible Oil Leaks		
The Hydraulic controls function properly		
The ROPS or ROPS Cab is in good condition		
The Seatbelt is in place and in good condition		
The 3-Point Hitch is in good condition		
The Drawbar pins are securely in place		
The PTO Master Shield is in place		
The Engine Oil level is full		
The Brake Fluid level is full		
The Power Steering Fluid Level is full		
The Fuel level is adequate		
The Engine Coolant Fluid level is full		
The Radiator is free of debris		
The Air filter is in good condition		

Operators Signature: _____

DO NOT OPERATE an UNSAFE TRACTOR or MOWER

OPERATION

FRONT END LOADER PRE-OPERATION Inspection



Mower ID# _____ Make _____

Date: _____ Shift _____

WARNING!



Before conducting the inspection, make sure the Tractor engine is off, all rotation has stop and the tractor is in the Park with the parking brake engaged. The Loader is resting on the ground (or is securely blocked up and supported) and all hydraulic pressure has been relieved.

Item	Condition at Start of Shift	Specific Comments if not O.K.
The Operator's Manual is in the Canister on the mower		
All Safety Decals are in place and legible		
The Mounting frame bolts are in place and tight		
There are no cracks in Draftbeam or Yolk		
The Draftbeam/Yolk connection bolts & pins are tight		
There are no cracks or holes in mower deck		
The Hydraulic motor mounting bolts are tight		
The mower head spindle housing is tight and lubricated		
There mower deck is clear of cut grass and debris		
The Skid shoes are in good condition & tight		
Chain Guards/Deflectors are in place & in good condition		
Blade carrier retaining nut is tight		
Blades are not chipped, cracked or bent		
Blade bolts are tight		
Transport locks are in good condition		
There are no leaking or damaged hoses		
There is no evidence of Hydraulic leaks		
The Hydraulic Oil level is full		
The Hydraulic Cylinders pins are tight		
The Hydraulic Pump hose connections are tight		
The Hydraulic Valve hose connections are tight		
The Hydraulic Valve controls function properly		
Wheel lug nuts are tight		

Operators Signature: _____

DO NOT OPERATE an UNSAFE TRACTOR or FRONT END LOADER

OPERATION

TRACTOR PRE-OPERATION Inspection



Tractor ID# _____ Make _____

Date: _____ Shift _____

WARNING!



Before conducting the inspection, make sure the Tractor engine is off, all rotation has stop and the tractor is in the Park with the parking brake engaged. The Loader is resting on the ground (or is securely blocked up and supported) and all hydraulic pressure has been relieved.

Item	Condition at Start of Shift	Specific Comments if not O.K.
The Flashing lights function properly		
The SMV Sign is clean and visible		
The Tires are in good condition with proper pressure		
The Wheel Lug bolts are tight		
The Tractor Brakes are in good condition		
The Steering linkage is in good condition		
There are no visible Oil Leaks		
The Hydraulic controls function properly		
The ROPS or ROPS Cab is in good condition		
The Seatbelt is in place and in good condition		
The PTO Master Shield is in place		
The Engine Oil level is full		
The Brake Fluid level is full		
The Power Steering Fluid Level is full		
The Fuel level is adequate		
The Engine Coolant Fluid level is full		
The Radiator is free of debris		
The Air filter is in good condition		

Operators Signature: _____

**DO NOT OPERATE an UNSAFE TRACTOR or FRONT END
LOADER**

MAINTENANCE SECTION

MAINTENANCE

Tiger Mowers are designed for high performance and rugged durability, yet with simplified maintenance. The purpose of this section of the manual is to help the operator in the regular servicing of the mower. Regular maintenance at the intervals mentioned will result in the maximum efficiency and long life of the Tiger Mower.

When you purchase a Tiger Mower you also acquire another valuable asset, Tiger's parts organization. Our rapid and efficient service has guaranteed the customer satisfaction for many years. Tiger parts keep up with the demands for efficiency, safety and endurance expected of the Tiger Mower.

MAINTENANCE PRECAUTIONS

- Be sure end of grease gun and zerks are clean before using. Debris injected into bearings, etc. with grease will cause immediate damage.
- DO NOT use a power grease gun to lubricate bearings. These require very small and exact amounts of lubrication. Refer to the detailed maintenance section for specific lubrication instructions. DO NOT over-grease bearings.
- Lexan windows should be washed with mild soap or detergent and luke warm water using a soft clean sponge or **soft cloth**. DO NOT use abrasive or alkaline cleaners or metal scrapers on lexan windows!
- Be alert to maintenance indicators such as the in-tank filter pressure gauge, hydraulic reservoir sight gauge, etc. Take the required action to correct any problems immediately
- Release of energy from pressurized systems may cause inadvertent actuation of cylinders, or sudden release of compressed springs. Before disconnecting any hoses relieve pressure by shutting tractor off, setting cutter on ground and actuating lift valve handles.

WARNING!



DO NOT use hands to check for suspected leaks in hydraulic hoses! Hydraulic fluid escaping under pressure can have sufficient force to penetrate skin and cause serious injury. If fluid is injected into skin, it must be surgically removed within a few hours or gangrene may result. Use a small piece of wood or cardboard, not hands, to search for pin hose leaks. Be sure all pressure is relieved whenever disconnecting lines. Be sure all connections are tight and hoses and lines are not damaged before applying pressure.

BREAK IN PERIOD

In addition to following the break in instructions for your particular tractor, the in-tank hydraulic fluid filter should be replaced after the first 50 hours of service. Thereafter the filter should be replaced every 500 hours, or yearly, whichever comes first.

Re-torque wheel lugs after first five hours of operation and periodically thereafter. See torque specifications listed in the tractor's service manual for your particular model. **Wheel lugs must always be re-torqued whenever a wheel is removed and reinstalled.**

MAINTENANCE

DANGER!



Never work under the Implement, the framework, or any lifted component unless the Implement is securely supported or blocked up to prevent sudden or inadvertent falling which could cause serious injury or even death. (SG-14)



WARNING!



Do not modify or alter this Implement. Do not permit anyone to modify or alter this Implement, any of its components or any Implement function. (SG-8)

WARNING!



Relieve hydraulic pressure prior to doing any maintenance or repair work on the Implement. Place the Mower Head on the ground or securely supported on blocks or stands, disengage the PTO, and turn off the engine. Push and pull the control Levers or Joystick several times to relieve pressure prior to starting any maintenance or repair work. (SBM-6)

DANGER!



Always disconnect the wire leads from the mower pump solenoid before performing service on the Tractor or Mower. Use caution when working on the Tractor or Mower. Tractor engine must be stopped before working on Mower or Tractor. The Mower Blades could inadvertently be turned on without warning and cause immediate dismemberment, injury or death. (SBM-12a)

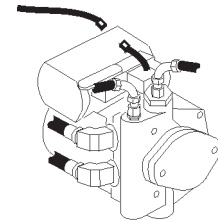

MAINTENANCE

REGULAR MAINTENANCE

The intervals at which regular servicing should be done are based on hours of operation. Use the tractors hour meter to determine when regular servicing is required.



This symbol indicates a point that needs to be greased at an interval noted in the section below. Refer to the Detailed Maintenance section for further instructions on greasing. Copy and use the Daily Maintenance sheet located at the end of this section.

DAILY OR EVERY 8 HOURS

ITEM	SERVICE	COMMENTS
Drive Shaft Yoke, U-Joint & Stub Shaft	Grease	Grease as instructed in detailed maint. section
Pump Drive Shaft Coupler	Check and Lube	insure drive shaft end play
Crankshaft Adapter	Check rubber grommets	Replace grommets if damaged or missing
Pivot Points	Lubricate	Inject grease until it appears at ends
Hydraulic Fittings Do Not use hands to	Check for leaks	Tighten when needed. check for leaks, see maint. Precautions
Knives	Check	Inspect for missing or damaged knives, change as needed
Spindle mounting bolts (spindle to deck)	Check	Torque to 331 ft. lbs. lubricated Torque to 357 ft. lbs. dry
Knife mounting bolts (knife to disk or knife to blade bar)	Check lubricated	Re-torque to 800 ft. lbs.
Disk / blade bar mounting bolts (disk to spindle)	Check	Torque to 180 ft. lbs. lubricated Torque to 204 ft. lbs. dry
Belts	Check / Adjust	Check if broken, tighten as required
Main Frame and Deck	Check	Retorque bolts to torque specifications in this section
Hydraulic Fluid Level	Check	Add if required per fluid recommendations
Rear Flail Drive (if applicable) Bearing Flange and Shaft Coupler	Lubricate	Grease as instructed in detailed maint. section
Cutter Shaft and Ground Roller	Lubricate	Grease as instructed in detailed maint. section.

MAINTENANCE

WEEKLY OR EVERY 50 HOURS

ITEM	SERVICE	COMMENTS
In Tank Hyd. Fluid Filter (10 micron filter)	Change	Change after first 50 hours only, then every 500 hours or yearly
In-Line High Pressure Filter (10 micron filter)	Change	Change after first 50 hours only, then every 500 hours or yearly

MONTHLY OR EVERY 150 HOURS

Hydraulic Fluid Level	Check	Add as needed
Hyd. Tank Breather	Clean / Check / Replace	Clean or replace Element as required
Rear Tire Type	Max P.S.I.	
480/80R38	29	
18.4-34	26	
18.4-38	26	

YEARLY OR EVERY 500 HOURS

Spindle Grease	Change	
Hyd. Tank Fluid	Change	
In Tank Hyd. Fluid Filter (10 micron filter)	Change	
In-Line HP Filter (10 micron filter)	Change	or Change when indicated by restriction indicator.
Hyd. Tank Breather	Change	

TROUBLESHOOTING

SYMPTOMS	CAUSE	REMEDY
Vibration	1. Loose bolts	1. Check all bolts and tighten to recommended torque specs.
	2. Cutter assembly Unbalanced	2a. Check for damaged blades, disc. or cutter shaft. Replace if needed. 2b. Check for wire, rope, etc. entangled in cutter assembly
Mower will not lift	1. Hyd. Fluid low	1. Check and refill Hyd Fluid
	2. Leaks in line	2. Tighten or replace fittings and hoses
	3. Faulty relief valve	3. Check pressure in line. Line pressure in Control Valve should be at least 2500 P.S.I.
	4. Kinked or blocked	4. Clean or replace lines
	5. Faulty cylinder	5. Inspect, repair or replace cylinder

MAINTENANCE

SYMPTOMS	CAUSE	REMEDY
Mower will not start or run	<ol style="list-style-type: none"> 1. Blown fuse 2. Ball valves closed 3. Low oil level 4. Line leak 5. Electronic solenoid faulty 	<ol style="list-style-type: none"> 1. Check fuse between mower switch and ignition / replace 2. Make sure valves are open 3. Check Hyd. tank and fill 4. Check all fittings and lines, re-tighten or replace 5a. Without the tractor running, turn the mower switch to on. A low audible click should be heard if the solenoid is engaging the solenoid spool. If click is not heard, leave switch in on position and with a screwdriver or other steel object, touch the small nut on the end of the solenoid. If the metallic object is not attracted to the nut, check the fuse and wiring for an open circuit. If the object is attracted but no "click" is heard, replace the solenoid. 5b. Remove the four bolts holding the small block to the main block. Lift and remove small block being careful not to damage O-rings / filter. Clean filter and re-install. 5c. Remove large nut on side of large valve block. Remove spring, and use needle nose vise grip to pull spool from block. Check block and spool for contaminates and scratches. Clean parts or replace if scratched.
Motor runs but will not cut.	<ol style="list-style-type: none"> 1. Belts 2. Tensioner 	<ol style="list-style-type: none"> 1. Inspect belts and pulleys. Replace belts and repair as needed. 2. Adjust tensioner nut until flat washer is flush with top of guide.
Motor turns slowly or not at all.	<ol style="list-style-type: none"> 1. Contaminants restricting spool movement in valve body. 2. Suction lines obstructed 3. Low oil level 	<ol style="list-style-type: none"> 1. Remove large nut on side of large valve block. Remove spring, and use needle nose vise grip to pull spool from block. Check block and spool for contaminates and scratches. Clean parts or replace if scratched. 2. Check for kinks or obstruction in suction hose. 3. Check Hyd. tank level and fill.
Pump will not work	<ol style="list-style-type: none"> 1. Excessive wear on internal parts 	<ol style="list-style-type: none"> 1. Disassemble and repair.
Motor will not work	<ol style="list-style-type: none"> 1. Excessive wear on internal parts 	<ol style="list-style-type: none"> 1. Disassemble and repair.

MAINTENANCE





NOTE: If flow meter is available, check pressure and flow volume for all suspected hydraulic problems.

If the solution to your problem cannot be found in this section, call the Technical Service representative at the number shown on the front cover of this manual.

MAINTENANCE

TORQUE SPECIFICATIONS

Torque for Standard Fasteners

Nominal Dia. (in.)	threads per inch	 Grade 2			 Grade 5			 Grade 8			 Grade 9		
		Tightening Torque			Tightening Torque			Tightening Torque			Tightening Torque		
		Lubed K = 0.15	Dry Plated K = 0.17	Dry plain K = 0.20	Lubed K = 0.15	Dry Plated K = 0.17	Dry plain K = 0.20	Lubed K = 0.15	Dry Plated K = 0.17	Dry plain K = 0.20	Lubed K = 0.15	Dry Plated K = 0.17	Dry plain K = 0.20

Unified Coarse Thread Series





1/4	20	49 in-lbs	59 in-lbs	66 in-lbs	76 in-lbs	86 in-lbs	101 in-lbs	107 in-lbs	122 in-lbs	143 in-lbs	126 in-lbs	143 in-lbs	168 in-lbs
5/16	18	101	122	135	157	178	209	221	251	295	259	294	346
3/8	16	15 ft-lbs	18 ft-lbs	20 ft-lbs	23 ft-lbs	26 ft-lbs	31 ft-lbs	33 ft-lbs	37 ft-lbs	44 ft-lbs	38 ft-lbs	43 ft-lbs	51 ft-lbs
7/16	14	24	29	32	37	42	49	52	59	70	61	70	82
1/2	13	37	44	49	57	64	75	80	90	106	94	106	125
9/16	12	53	63	70	82	92	109	115	130	154	135	153	180
5/8	11	73	87	97	113	128	150	159	180	212	186	211	248
3/4	10	129	155	172	200	227	267	282	320	376	331	375	441
7/8	9	125	150	167	322	365	429	455	515	606	533	604	710
1	8	187	225	250	483	547	644	681	772	909	799	905	1065
1 1/8	7	266	319	354	596	675	794	966	1095	1288	1132	1283	1510
1 1/4	7	375	450	500	840	952	1121	1363	1545	1817	1597	1810	2130
1 1/2	6	652	783	869	1462	1657	1950	2371	2688	3162	2779	3150	3706

Fine Thread Series

1/4	28	96 in-lbs	68 in-lbs	75 in-lbs	87 in-lbs	99 in-lbs	116 in-lbs	123 in-lbs	139 in-lbs	164 in-lbs	144 in-lbs	163 in-lbs	192 in-lbs
5/16	24	112	135	150	174	197	231	245	278	327	287	325	383
3/8	24	17 ft-lbs	20 ft-lbs	23 ft-lbs	26 ft-lbs	30 ft-lbs	35 ft-lbs	37 ft-lbs	42 ft-lbs	49 ft-lbs	43 ft-lbs	49 ft-lbs	58 ft-lbs
7/16	20	27	32	36	41	47	55	58	66	78	68	78	91
1/2	20	41	49	55	64	72	85	90	102	120	105	120	141
9/16	18	59	71	78	91	103	121	128	146	171	151	171	201
5/8	18	82	99	110	127	144	170	180	204	240	211	239	281
3/4	16	144	173	192	223	253	297	315	357	420	369	418	492
7/8	14	138	165	184	355	403	474	502	568	669	588	666	784
1	14	210	252	280	542	614	722	765	867	1020	896	1016	1196
1 1/8	12	298	357	397	668	757	890	1083	1227	1444	1269	1439	1693
1 1/4	12	415	498	553	930	1055	1241	1509	1710	2012	1768	2004	2358
1 1/2	12	734	890	978	1645	1865	2194	2668	3024	3557	3127	3544	4169

Torque values for 1/4 and 5/16-in series are in inch-pounds. All other torque values are in foot-pounds. K = 0.15 for "lubricated" conditions. D = Nominal Diameter
 Torque values calculated from formula T=KDF, where K = 0.17 for zinc plated and dry conditions. F = Clamp Load
 K = 0.20 for plain and dry conditions.

Torque-Tension Relationship for Metric Fasteners

Nominal Dia. (mm)	Pitch	 Class 4.6			 Class 8.8			 Class 10.9			 Class 12.9		
		Tightening Torque			Tightening Torque			Tightening Torque			Tightening Torque		
		Lubed K = 0.15	Dry Plated K = 0.17	Dry plain K = 0.20	Lubed K = 0.15	Dry Plated K = 0.17	Dry plain K = 0.20	Lubed K = 0.15	Dry Plated K = 0.17	Dry plain K = 0.20	Lubed K = 0.15	Dry Plated K = 0.17	Dry plain K = 0.20
3	0.5	0.28	0.32	0.38	0.73	0.82	0.97	1.0	1.2	1.4	1.2	1.6	
3.5	0.6	0.44	0.50	0.59	1.1	1.3	1.5	1.6	1.9	2.2	1.9	2.5	
4	0.7	0.66	0.74	0.87	1.7	1.9	2.3	2.4	2.7	3.2	2.8	3.8	
5	0.8	1.3	1.5	1.8	3.4	3.9	4.5	4.9	5.5	6.5	5.7	7.6	
6	1	2.3	2.6	3.0	5.8	6.6	7.7	8.3	9.4	11	9.7	13	
6	1.25	2.1	2.3	2.7	5.3	6.0	7.0	7.6	8.6	10	8.8	12	
7	1	3.8	4.3	5.0	9.7	11	13	14	16	19	16	22	
8	1	5.9	6.6	7.8	15	17	20	22	24	29	25	34	
8	1.25	5.5	6.2	7.3	14	16	19	20	23	27	24	31	
10	1.25	11	13	15	29	33	39	42	48	56	49	66	
10	1.5	11	12	14	28	32	37	40	45	53	47	62	
12	1.25	21	23	28	53	60	71	76	86	101	89	119	
12	1.5	20	22	26	51	58	68	73	82	97	85	113	
12	1.75	19	21	25	49	55	65	70	79	93	81	108	
14	1.25	26	29	34	66	75	89	95	108	127	111	148	
14	1.5	28	32	37	72	82	96	103	117	138	121	161	
14	2	30	34	40	78	88	104	111	126	148	130	173	
16	1.5	50	57	67	129	146	171	184	208	245	215	287	
16	2	47	53	62	121	137	161	173	196	230	202	269	
18	1.5	73	82	97	187	212	249	268	303	357	313	417	
18	2.5	65	73	86	167	189	222	239	270	318	279	372	
20	2.5	91	104	122	236	267	314	337	382	449	394	525	

Clamp load calculated as 75% of the proof load for specified bolts. K = 0.15 for "lubricated" conditions. D = Nominal Diameter
 All torque values are listed in foot-pounds. K = 0.17 for zinc plated, dry conditions. F = Clamp Load
 Torque values calculated from formula T=KDF, where K = 0.20 for plain and dry conditions.

* These are intended to be general specifications. See tractor operators or service manual for exact specifications for your unit.

MAINTENANCE

LUBRICATION RECOMMENDATIONS

Description	Application	General Specification	Recommended Mobil Lubricant
Tractor Hydraulics	Reservoir	JD-20C MF M1135,M1141 FNHM2C134D (FNH201)	Mobilfluid 424
Mower Hydraulics	Reservoir		
Cold Temperatures 0 F Start-Up		ISO 46 Anti-Wear - Low Temp	Mobil DTE 15M
Normal Temperatures 10 F Start-Up		JD-20C MF M1135,M1141 FNH M2C134D (FNH201)	Mobilfluid 424
Normal Temperatures 15 F Start-Up		ISO 46 Anti-Wear	Mobil DTE 25
High Operating Temp. Above 90 F		ISO 100 Anti-Wear	Mobil DTE 18M
Flail Rear Gearbox	Grease	PAO Synthetic Extreme Pressure Gear Lube	Mobil SHC 75W-90 Mobil 1 Synthetic Gear
Cutter Shaft & Ground Roller Shaft (Flail)	Grease Gun	Lithium-Complex Extreme Pressure NLGI 2 - ISO 320	Mobilgrease CM-S
Drive Shaft Coupler (Flail and Rotary)	Grease Gun	Lithium-Complex Extreme Pressure NLGI2 - ISO 320	Mobilgrease CM-S
Drive Shaft Yoke, U-Joint & Sub Shaft	Grease Gun	Lithium-Complex Extreme Pressure NLGI 2 - ISO 320	Mobilgrease CM-S
Boom Swivel Boom Cylinder Pivots (Rotary & Flail Boom)	Grease Gun	Lithium-Complex Extreme pressure NLGI2 - ISO 320	Mobilgrease CM-S
Deck Boom Pivot & Deck Stop Adjustment (Rotary & Flail)	Grease Gun	Lithium-Complex Extreme pressure NLGI 2 - ISO 320	Mobilgrease CM-S
Deck Spindle (Rotary)	Grease Gun	Tiger Spindle Lubricant part number 06540000	Mobilith SHC 220

MAINTENANCE

POLYCARBONATE CARE & MAINTENANCE

The proprietary UV and Abrasion Resistant surface coating on SHIELDS® SUPERCOATED™ polycarbonate significantly improves performance. Periodic cleaning using proper procedures and compatible cleaners are recommended to prolong service life. Tiger Corp. polycarbonate is SUPERCOATED™ on both sides.

CLEANING THE SUPERCOAT™ HARD-COAT

1. Wash with a mild solution of soap or detergent and lukewarm water
2. Using a soft cloth or sponge, gently wash the sheet to loosen dirt and grime and rinse well with clean water.
3. To prevent water spotting, thoroughly dry with chamois or cellulose sponge.
4. Avoid the use of abrasive cleaners, squeegees and/or other cleaning implements that may mar or gouge the coating.

CLEANING AGENTS WHICH HAVE BEEN FOUND TO BE COMPATIBLE UNDER LABORATORY CONDITIONS:

- Aqueous Solutions of Soaps and Detergents
Windex¹ Top Job² Joy² Mr. Clean²
Fantastik³ Formula 409⁴ Sumalight D12 Brucodecid
- Organic Solvents
Butyl Cellosolve Kerosene Hexel, F.O. 554 Naphtha (VM&P grade)
Neleco-Placer Turco 5042
- Alcohols
Methanol Isopropyl

All residual organic solvents should be removed with a secondary rinse.

GRAFFITI REMOVAL

Butyl cellosolve (for removal of paints, marking pen inks, lipstick, etc.). The use of masking tape, adhesive tape or lint removal tools works well for lifting off old weathered paints.

To remove labels, stickers, etc., the use of kerosene or VM&Pnaphtha are generally effective. When the solvent will not penetrate sticker material, apply heat (hair dryer) to soften the adhesive and promote removal.

IMPORTANT: If a material is found to be incompatible in a short-term test, it will usually be found to be incompatible in the field. The converse, however, is not always true. Favorable performance is no guarantee that actual end-use conditions have been duplicated. Therefore, these results should be used as a guide only and it is recommended that the user test the products under actual end-use conditions.

MAINTENANCE

RECOMMENDED FILLING INSTRUCTIONS FOR HYDRAULIC RESERVIORS

When filling or checking the oil level, the unit should be parked on a level surface, shut “OFF”, and allowed sufficient time to cool to ambient temperature. Use caution when removing the pressurized breather. Do not place face over opening when removing the breather.

The reservoir should be filled to the top of the lower sight glass on the side of the tank OR check the sight guage for the appropriate level. Do not over-fill. The reservoir has been over-filled when oil is visible in the upper sight glass. If tank has too much oil, the excess may be expelled through the pressurized breather.

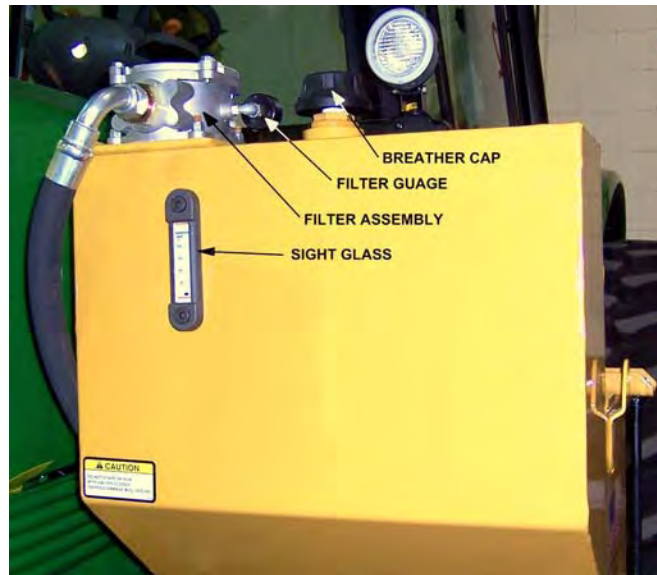

REPLACING IN-TANK HYDRAULIC FILTER:

Loosen the four bolts on the top cover of the filter housing. Turn cover counter-clockwise until cover is free. Remove and replace filter. Replace top cover and cover bolts in opposite order as removed.

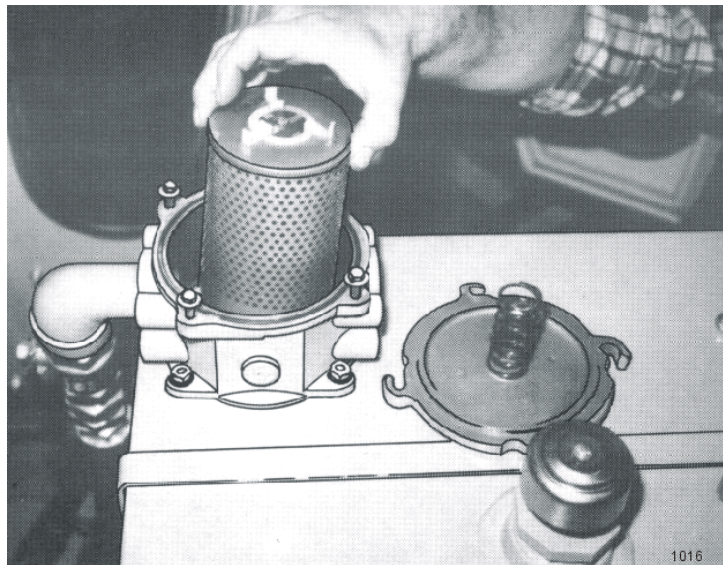

MAINTENANCE

DETAILED MAINTENANCE

FOR TRACTORS EQUIPPED WITH A HIGH PRESSURE HYDRAULIC FILTER REPLACING FILTER ELEMENT:

Assure system has been shut down and de-pressurized. Locate High Pressure Filter housing. Confirm that the element that is about to be installed matches the element p/n on the filter model tag. Example: V3.0510-06 (world line 100, HD049 model) Locate the bottom of the High Pressure Bowl, and use the appropriate spanner wrench –or- ratchet that matches the hex pattern. Using the spanner wrench -or- ratchet and turning in a counterclockwise rotation, (looking at the bottom of the bowl) remove the bowl from the head. The first couple rotations will seem tight as the o-ring passes the sealing flats, once the o-ring has cleared the sealing flats the bowl should spin freely. Taking care not to drop the bowl, finish removing the bowl from the head. **WARNING:** bowl will be full of oil! Pour the oil from the bowl into a container, this oil should be considered contaminated due to the flow direction through the element is outside ~ in. Clean the inside of the bowl if “dirt” is present. Remove the old element from the filter head by pulling with a rotation motion. Dispose of the used element properly. Remove the new element from the packaging. Using your finger, dab and lubricate the o-ring in the top of the new element. Install the new element into and on the mounting boss with in the head; assure that the element is fully seated on the boss. Clean and inspect the o-ring that is affixed in the bowl, lubricate with oil. Using a clockwise rotation, screw the bowl back into the head, assuring that the bowl has not been cross threaded into the head. Continue “tighten” the bowl into the head, using the spanner wrench –or- ratchet, the rotation of the bowl will become tighter once the o-ring engages the sealing flats. Once the bowl has been fully inserted into the head, and the o-ring has reached the sealing flats, the bowl can no longer be “tightened” and bottoms out. Once the bowl has bottomed out, “back-off” the bowl by 1/6 turn, this assures that the o-ring is seated properly with in the sealing flats. Element change out and re-assembly is now complete. Start the machine and inspect the filter area checking that there is no oil leaking from the filter assembly. This is first to be done at 50 hours of operation, then yearly(500 hours) or when indicated by restriction indicator

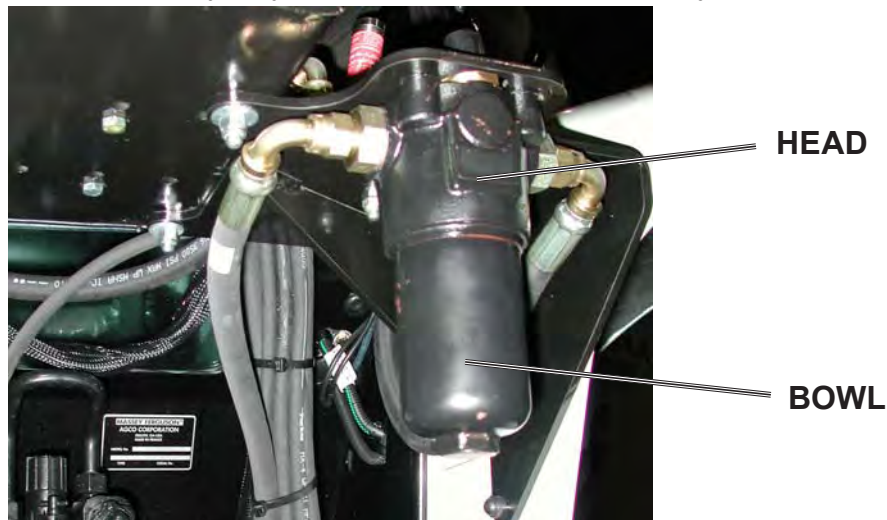

MAINTENANCE

GREASING CUTTER SHAFT – FLAIL MOWERS

Locate grease zerks on each end of cutter shaft(s), these are located on the bearing cover. Normal conditions require one or two pump in each bearing, using Lithium-Complex Extreme Pressure grease conforming to NLGI2-ISO 320 specifications. This is to be done with a standard grease gun daily or at **8 hour intervals**. **CAUTION: Over greasing may cause premature seal failure.**

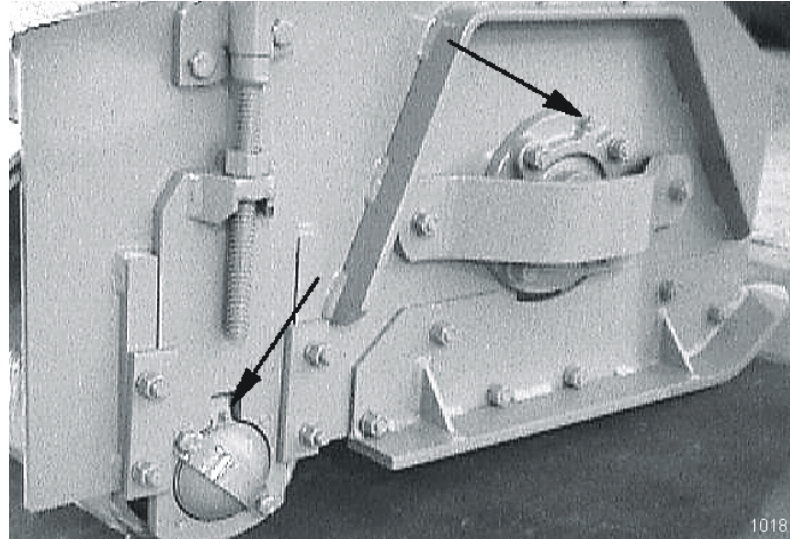

GREASING GROUND ROLLER SHAFT – FLAIL

Locate grease zerks on each end of roller tube at lower rear of head. Normal conditions require one or two pump in each bearing, using Lithium-Complex Extreme Pressure grease conforming to NLGI2-ISO 320 specifications. This is to be done with a standard grease gun daily or at **8 hour intervals**. **CAUTION: Over greasing may cause premature seal failure.**

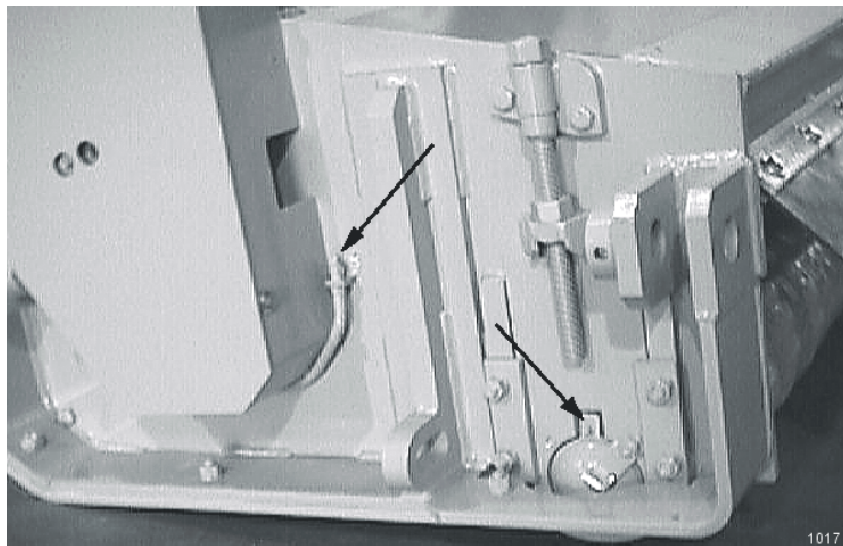

MAINTENANCE

ADJUSTING / CHECKING BELT TENSION

To adjust belt tension or replace belt s on flail cutter head, remove four bolt s that secure belt cover and remove cover. The hex nuts shown below can be adjusted to increase / decrease the belt tension as needed. (NOTE: Location of adjustment nuts may vary on flail cutter heads.) **Be sure to replace the belt cover BEFORE operating mower!**

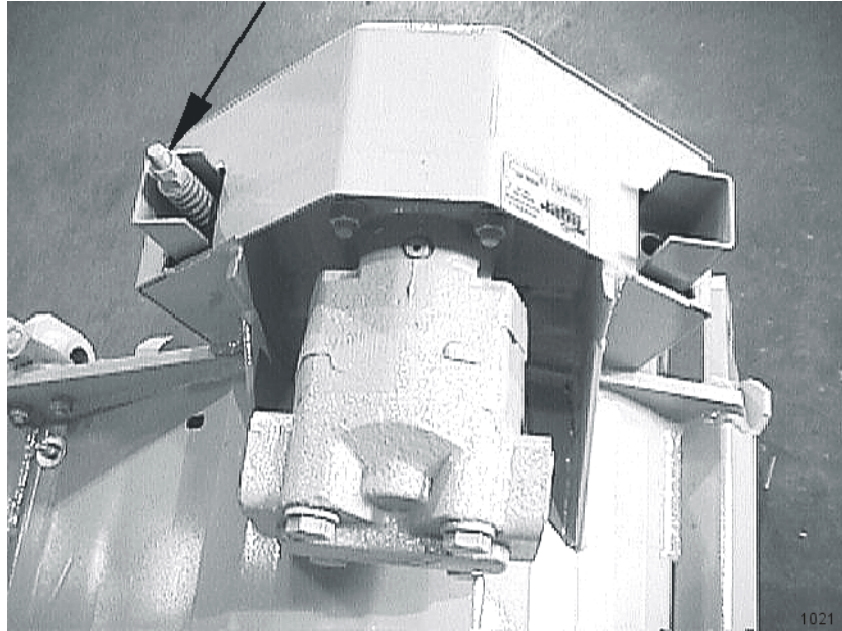

TIGHTENING KNIFE BOLTS AND DISK BOLTS:

After every 8 hours of operation or daily, the Knife Bolts and Disk Bolts should be tightened as follows:

Knife mounting bolts (2ea) torque to 800 ft. lbs. lubricated

Disk mounting bolts (6ea) torque to 204 ft. lbs. dry or 180 ft. lbs. lubricated (loctite 271)

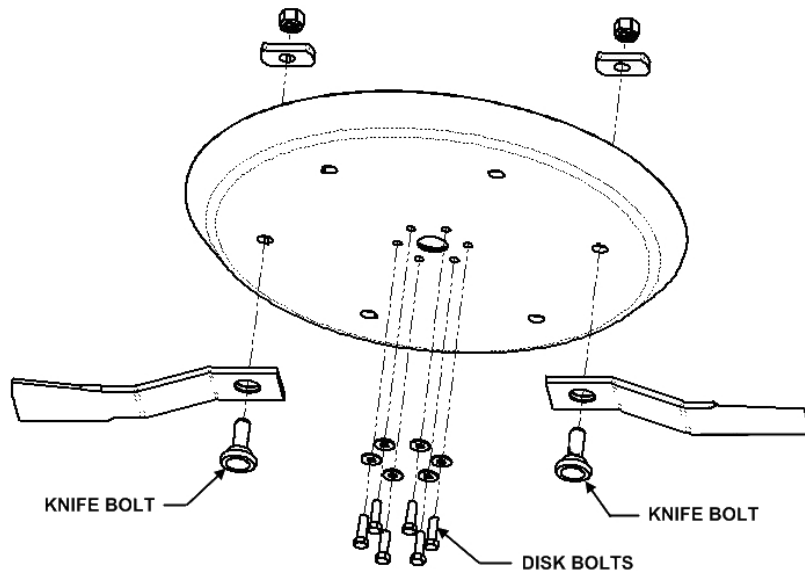

MAINTENANCE

GREASING POINTS ON BOOM AND PIVOT

Locate grease zerks (8) on deck pivot assembly , (2) on deck end of secondary boom, (2) at main / secondary boom joint, and (2) at swivel end of main boom. Inject Lithium-Complex Extreme Pressure grease conforming to NLGI2-ISO 320 specifications until grease begins to protrude from ends.

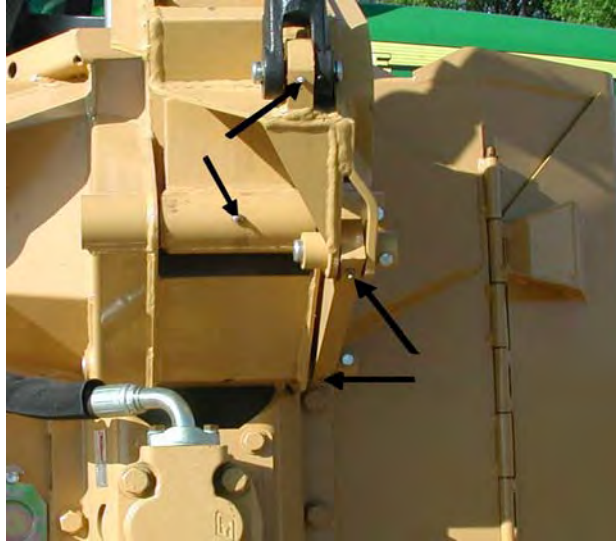

DECK STOP ADJUSTMENT

Loosen locking nut. Turn adjustment bolt in, and run deck cylinder out to full extension. Adjust bolt out until the head just touches the boom, and tighten lock nut.

NOTE: Bolt should not hit boom before cylinder reaches full travel.



MAINTENANCE

GREASING SPINDLE

Locate grease fitting on inside of deck housing. Inject Tiger Spindle Lubricant, part number 06540000 into spindle housing. Fill with lubricant until lubricant weeps out of top spindle seal. Lubricate spindle weekly or every 40 hours of use.



TIGHTENING SPINDLE BOLTS

The spindle mounting bolts should be checked and retorqued daily or every 8 hours of service. Torque the (6) bolts shown below as follows:

Torque to 315 ft. lbs. lubricated (loctite 271)

Torque to 357 ft. lbs. dry

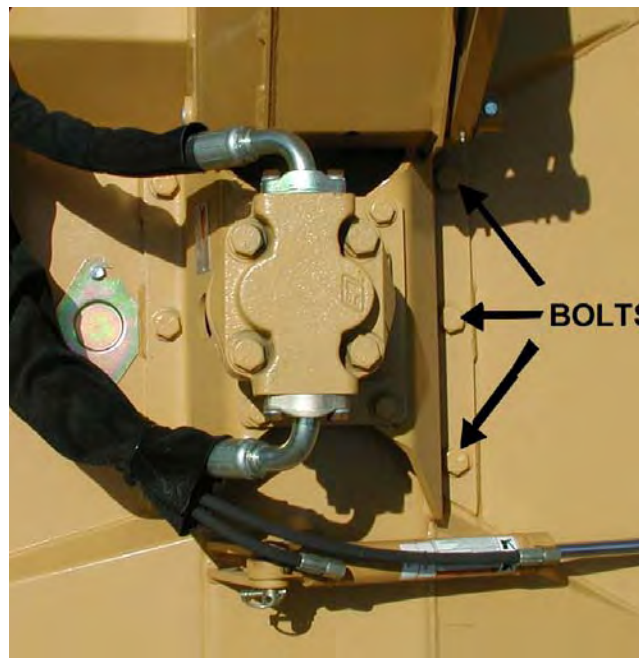

MAINTENANCE

GREASING PUMP DRIVE SHAFT COUPLER

With engine stopped, ensure drive shaft alignment by grasping coupler and sliding back and forth. Coupler should slide freely with approximately 1/8" of end play. If coupler does not slide freely, inspect for loose pump mount bolts, or damaged or loose crank shaft adapter. Inject Lithium-Complex Extreme Pressure grease conforming to NLGI2-ISO 320 specifications into coupler until grease begins to protrude from ends. Grease daily or every 8 hours. Do not over grease.

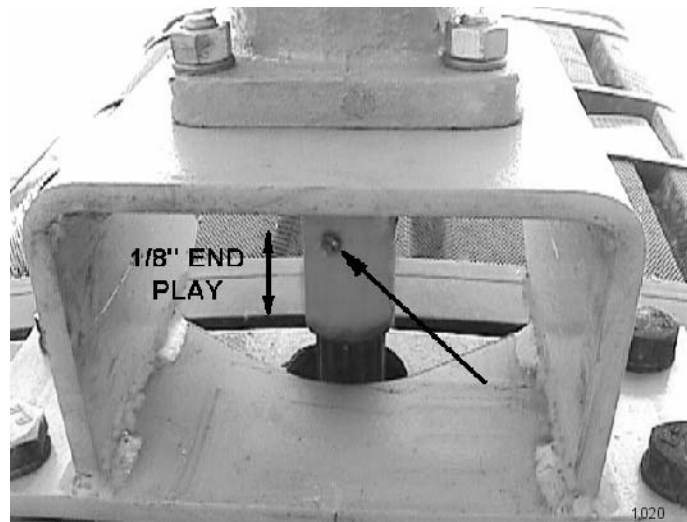

DRIVE SHAFT YOKE, U-JOINT & STUB SHAFT

With engine stopped, inject Lithium-Complex extreme pressure grease conforming to NLGI2-ISO 320 specifications into universal joints and slip yoke until grease appears at the seal. Grease them daily or every 8 hours.

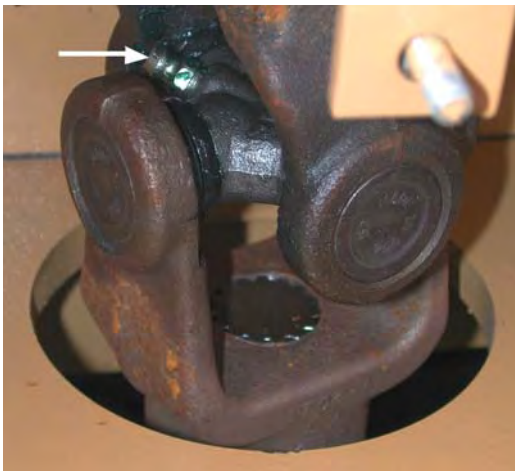

MAINTENANCE

GREASING THE BOOM SWIVEL

Locate the zerks on the main swivel boss (2), main boom pivot boss (2) and on both ends of the boom swivel cylinder. Inject Lithium-Complex Extreme Pressure grease conforming to NLGI2-ISO 320 specification until grease begins to protrude from ends.

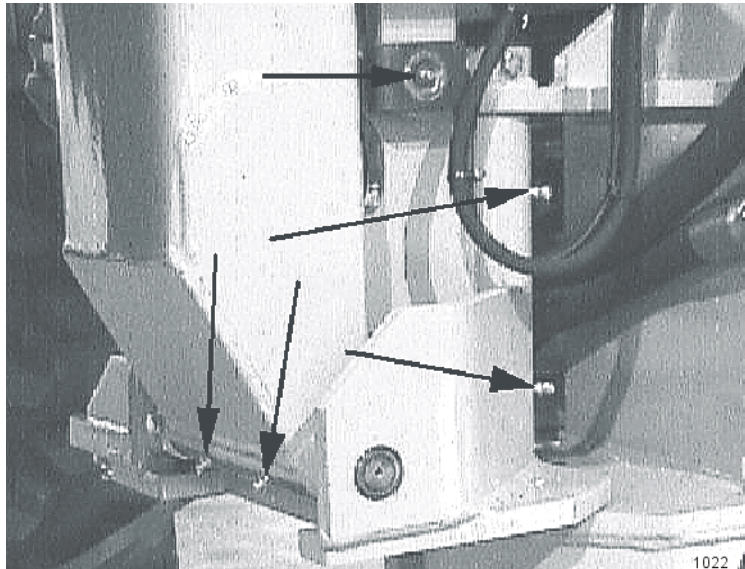

GREASING BOOM CYLINDER(S) PIVOT POINTS

Locate the zerk on the butt end tang of cylinder and on rod end tang. Inject Lithium-Complex Extreme Pressure grease conforming to NLGI2-ISO 320 specifications until grease begins to protrude from ends. This procedure is to be used on the main boom cylinder, secondary boom cylinder, deck pivot, and swivel cylinders daily or at 8 hour intervals.

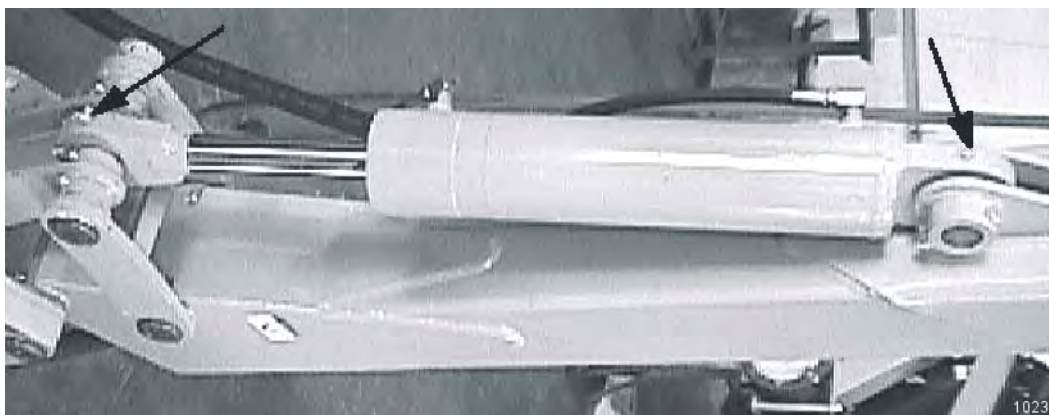

MAINTENANCE

BALL VALVES

The ball valve at the hydraulic reservoir may need to be closed during certain maintenance or repair procedures. **THE BALL VALVES MUST BE OPEN (handle parallel with valve) WHEN TRACT OR IS RE-STARTED OR PUMP IS COUPLED TO MOTOR OR P.T.O. !** Failure to do so will result in component failure!

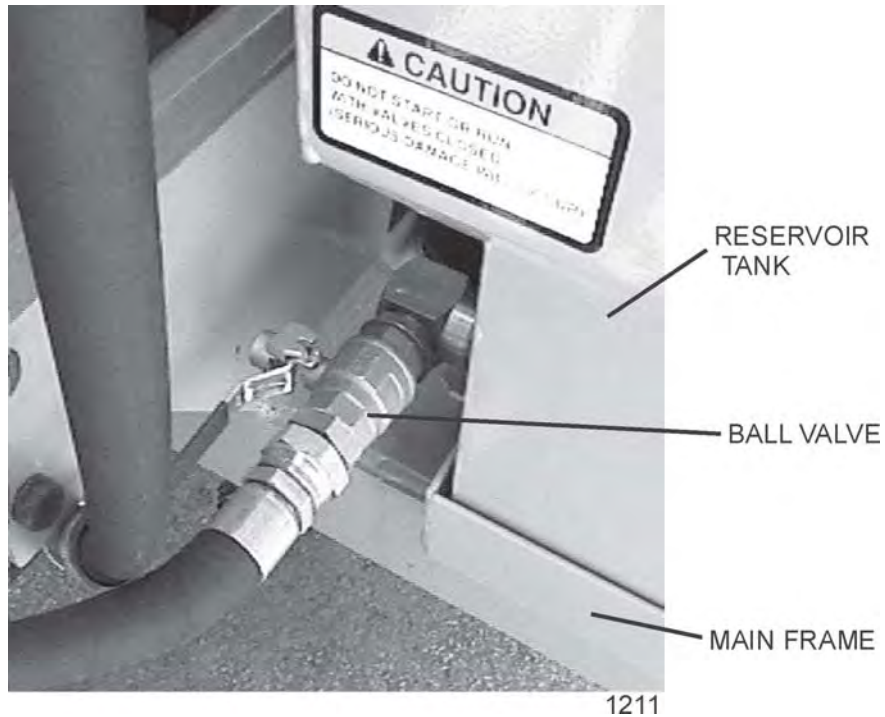

MAINTENANCE

INSPECTION OF ROTARY KNIFE

CAUTION!



Failure to follow the following warnings and instructions may result in serious injury or damage to the equipment or property!

- 1 – **DO NOT** weld on the knives or bolts. Damaged or worn knives must be replaced.
- 2 – Knives must be replaced in sets. **Knives with unequal wear may cause serious vibration and resulting structural damage to the mower .**
- 3 – The self-locking nuts for the knife mounting bolts must **NOT** be reused. If the self-locking nut is removed from the knife mounting bolt, the nut **must** be replaced with a new self-locking nut.
- 4 – Inspect the condition and tightness of the knife mounting bolts and disk mounting bolts daily.

ROTARY KNIFE REPLACEMENT

- 1 – Be sure you have a complete matching set of new knives for replacement.
- 2 – Remove knives and inspect holes for damage. Also watch for cracks in the disk around the holes..
- 3 – Lube threads with anti-seize. Install bolt through knife and disk from bottom side of disk. Install new self-locking nuts and torque them to 800 ft. lbs.
- 4 – The knives should swing freely to absorb shocks from impact when striking objects.

WARNING!



WHEN CUTTING HEAVY BRUSH, KNIFE BOLTS SHOULD BE INSPECTED HOURLY AND RETORQUED TO 800 FT. LBS. LUBRICATED

MAINTENANCE

REPLACEMENT OF ROTARY DISK OR BAR

CAUTION!



Failure to follow the following warnings and instructions may result in serious injury or damage to the equipment or property!

- 1 – The bolts that attach the disk to the spindle must be grade 8. These 5/8 inch bolts are to be torqued to 180 ft. lbs. lubricated (loctite 271) or 204 ft. lbs. dry
- 2 – A thread locking agent may be applied to threads of all mounting bolts before they are installed.
- 3 – **Disks must be inspected daily for hairline cracks between spindle mounting bolts or around the knife mounting bolts. These cracks indicate metal fatigue caused by severe abuse. If cracks are present the disk must be replaced.**
- 4 – Inspect the disk mounting bolts daily when checking tightness of knife mounting bolts. If a disk mounting bolt is loose, it must be removed, threads cleaned, fresh thread locking agent applied, and tightened to proper torque value.
- 5 – If a knife mounting bolt is loose, the self locking nut must be replaced as a safety precaution. Lubricate threads with anti-seize. Install bolts through knife and disk or blade bar from bottom side. Install self locking nuts and torque them to 800 ft. lbs.

50” FLAIL KNIFE BLADE REPLACEMENT

- 1 – If knives are damaged or badly worn, they will need to be replaced as a safety precaution. **Replacing a single knife can cause severe vibration and possible damage to the mower . The knife should not be welded on for any reason.**
- 2 - Always replace the knife bolts when replacing the knives. **DO NOT REUSE THE KNIFE BOLTS OR NUTS.**
- 3 – Assemble knives, bushings, bolts and nuts as shown in part section of the manual.
- 4 – Install the locking hex nut so that the flat face of the nut is towards the knife.
- 5 – apply loctite “271” or equivalent to threads.
- 6 – Torque nut to 50 ft lbs. Knife must swing freely.

WARNING!



DO NOT re-use the locking hex nuts for mounting the knives. If hex nut become loose, or require removal for knife replacement or any other reason, they must be discarded and replaced with new nuts.

MAINTENANCE

63" BOOM FLAIL KNIFE REPLACEMENT

1 – If knives are damaged or badly worn, they will need to be replaced as a set. **Replacing a single knife can cause severe vibration and possible damage to the mower .**

2 – Assemble knives, clevis, bolts and nuts as shown in part section of manual.

3 – Install locking hex nut so that the flat face of nut is towards the knife.

4 – Torque nut to 35 FT. LBS. Knife must swing freely.

WARNING!



DO NOT re-use the locking hex nuts for mounting the knives. If hex nut become loose, or require removal for knife replacement or any other reason, they must be discarded and replaced with new nuts.

WARNING!



Knives should not be welded on for any reason.

MAINTENANCE

HEAVY DUTY SPINDLE ASSEMBLY INSTALLATION AND BEARING ADJUSTMENT

WARNING! A press MUST be used to install bearing cups, bearing cones, and seals. DO NOT use a hammer to install races, bearings, or seals. The parts of assembly may be damaged.

NOTE: The grease zerk and gussets are located on the top side of the spindle housing. Be sure the spindle is assembled correctly.

Be sure to wear eye protection and other protective equipment as needed when working on spindle assembly.

THE SPINDLE ASSEMBLY

See the diagram below for identification of spindle parts, while servicing.

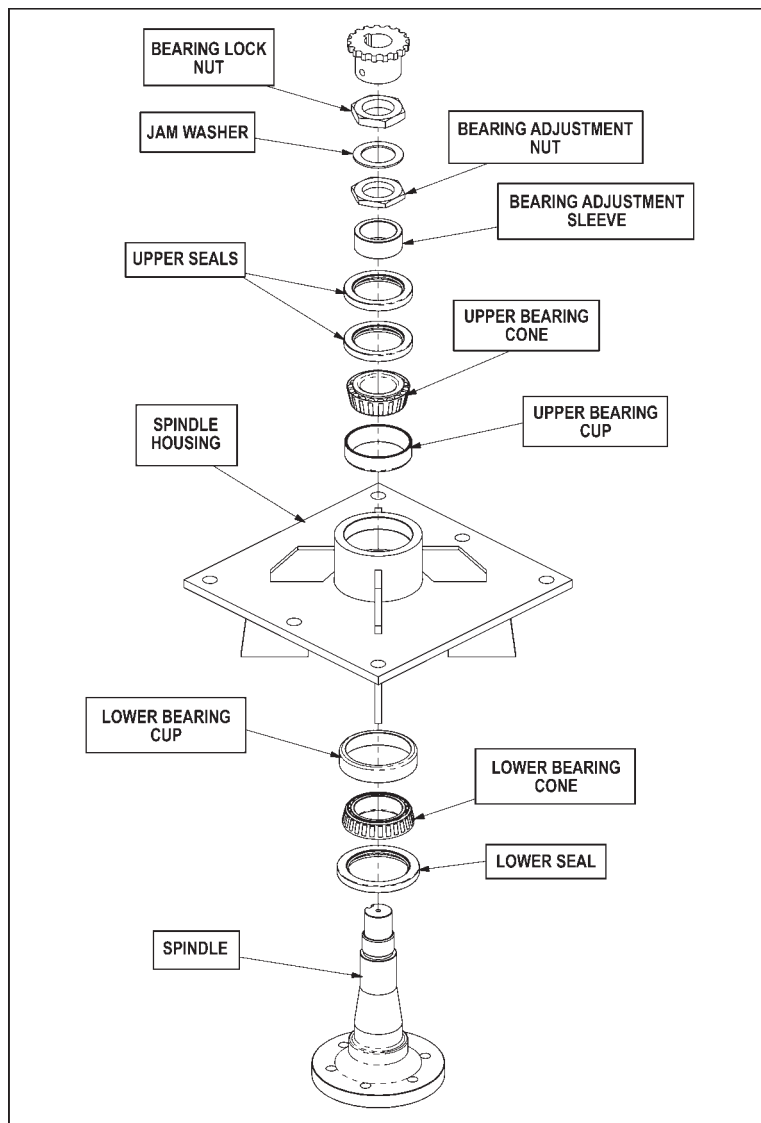

MAINTENANCE

BEARING INSTALLATION

- 1 – Press upper bearing cup into the spindle housing.
 - 2 – Turn the spindle housing over and press in the lower bearing cup.
 - 3 – Place the lower bearing cone in the bearing cup. Next press the seal into the spindle housing. The inner lip of the seal must be DOWN, towards the bearing, so lubricant is sealed inside the housing.
 - 4 – Install the spindle in the housing. Lightly press the spindle to seat the cone onto the spindle.
 - 5 – Support the bottom of the spindle and press the upper bearing cone and bearing adjustment sleeve onto the spindle.
- NOTE:** The spindle housing must turn freely when seating the bearing cone and sleeve.
- 6 – Press the two upper seals into the spindle housing. The inner lip of the seals must be UP, away from the bearing, so excess lubricant can escape.
 - 7 – Install the bearing adjustment nut (thin nut) so there is 1/16" clearance between the nut and the sleeve. Install the jam washer, placing the tab into the key-way. Install the bearing lock nut (thick nut) and hand tighten against jam washer and adjustment nut. See the following section for bearing adjustment.
 - 8 – Position the spindle housing horizontally with the drain hole oriented "up." Grease through the zerk with Tiger Spindle Lubricant(part number 06540000) until the grease purges from the drain hole.
 - 9 – Install the plug into the drain hole.

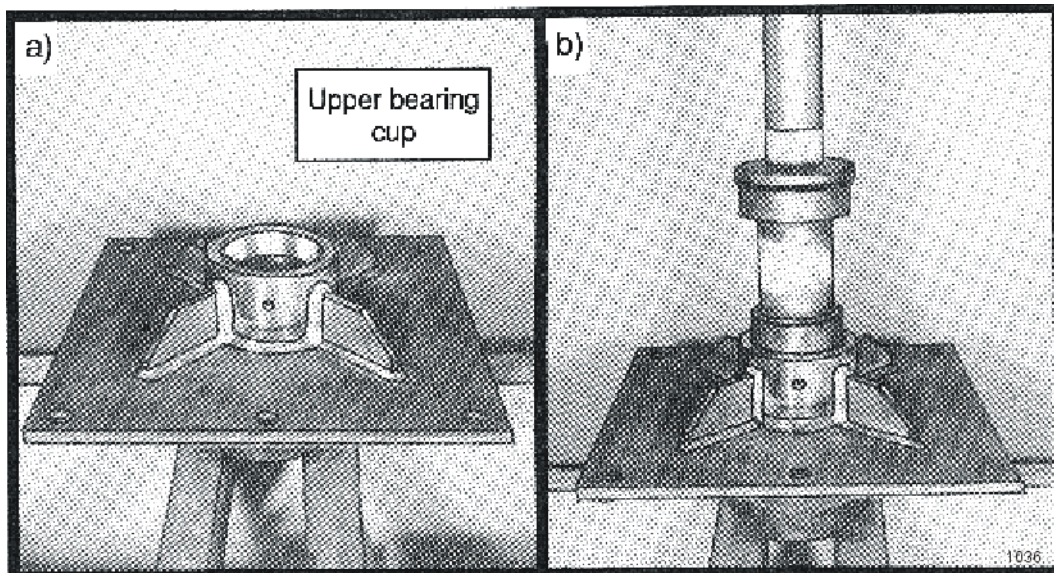

MAINTENANCE

BEARING ADJUSTMENT

1 – Clamp the bottom end of the spindle securely in a vise so the spindle housing turns freely.

2 – Position a magnetic base dial indicator on the outer diameter of the spindle housing. Locate the end of the dial indicator against the flat end of the spindle shaft. The dial indicator will now measure accurately bearing end play.

3 – Tighten the bearing adjustment nut until there is .012 inch movement when the spindle housing is pried upward away from the vise jaws.

4 – When there is .012 inch free play between the spindle and housing, install the bearing lock nut (thick nut). Hold the adjusting nut securely and tighten the lock nut to 300 ft. lbs. of torque.

5 – After the lock nut is tightened, there must be .001 inch to .003 inch of free play when lightly prying up on the spindle housing.

If the end play is NOT correct, loosen the lock nut and turn the adjustment nut as required and re-tighten the lock nut. Repeat first part of step 5.

If the end play is correct, .001 inch to .003 inch, bend tabs up on jam washer to prevent the lock nut from loosening.

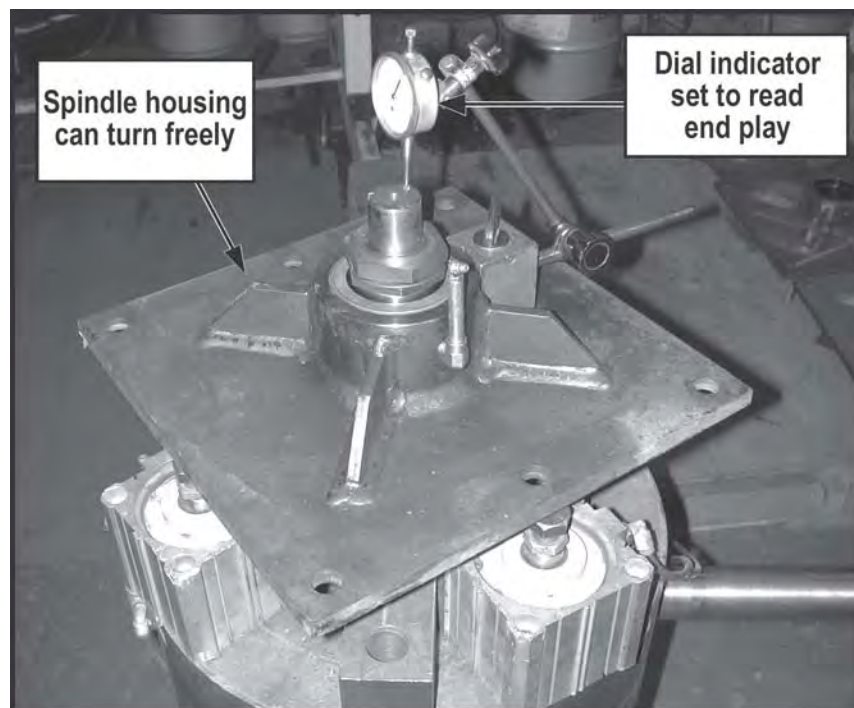

MAINTENANCE

CUTTERSHAFT BEARING REPLACEMENT

- 1 – Remove existing cuttershaft, bearings and string guards.
- 2 – Make sure that the end knives on each end of the cuttershaft are orientated as shown.
- 3 – Apply anti-seize on cuttershaft as shown on next page.
- 4 – Install non-drive side bearing first.
- 5 – Install the top of the string guard on the non-drive side first. Use loctite-271 or equivalent and torque (95 ft-lb or 104ft-lb if you use an extension).
- 6 – Install the bearing and top string guard on the drive side.
- 7 – Center the cuttershaft between the string guards. Use loctite-271 or equivalent and torque (95ft-lb or 104ft-lb if you use an extension) the top string guard on the drive side.
- 8 – Install, use loctite-271 or equivalent, and torque (95ft-lb or 104ft-lb if you use an extension) the bottom string guard on both sides.
- 9 – Make sure the cuttershaft is centered. On the non-drive side, tighten one set-screw in the bearing onto the cuttershaft.
- 10 – Remove the other set-screw and drill a 5/16" hole into the cuttershaft 3/16" deep through the hole in the bearing. BE CAREFULL NOT TO DAMAGE THE THREADS IN THE BEARING HOLE.
- 11 – Replace the set-screw in the bearing, use loctite-271 or equivalent, and tighten onto the cuttershaft through the new hole.
- 12 – Remove the other set-screw and repeat the drilling procedure (Step 10). Replace the set screw as stated in Step 11.
- 13 – Repeat steps 9 through 12 on the drive side.
- 14 – Grease both bearings properly.

MAINTENANCE

CUTTERSHAFT BEARING REPLACEMENT

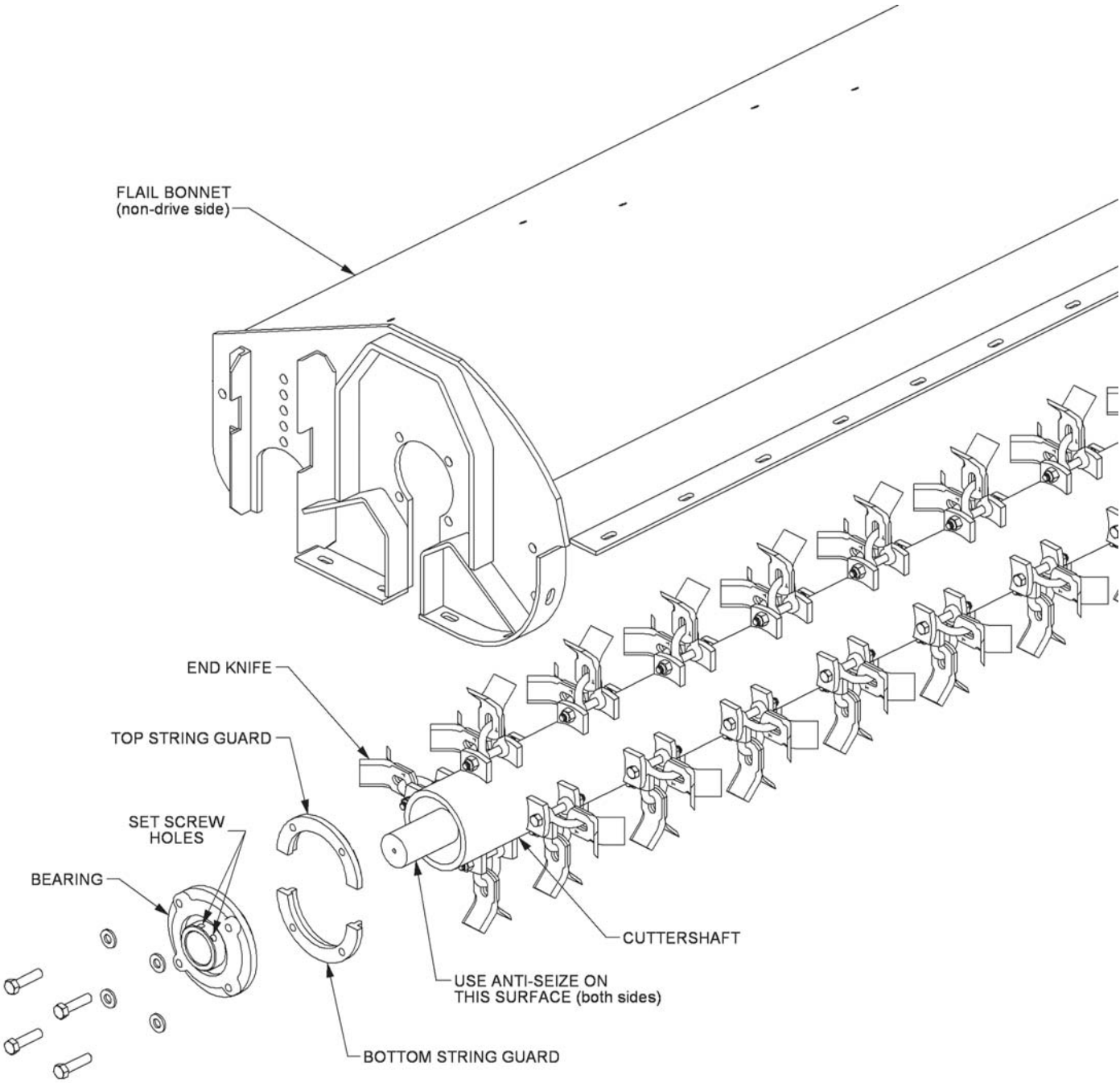

MAINTENANCE

DAILY MAINTENANCE SCHEDULE

The following services should be performed **daily** or every **8 hours** of service, following the detailed maintenance instructions in the operators manual.

- _____ Pump Drive Shaft: If required with drive shaft / coupler check for end play and lubricate at zerks.
- _____ Crankshaft adapter: If equipped with rubber grommets check condition, replace if missing or damaged.
- _____ Pivot points: Inject grease until it appears at ends.
- _____ Hydraulic fittings: Check for leaks with paper or cardboard. Tighten fittings or replace hoses immediately
- _____ Knives: Inspect for missing or damaged knives, change (only complete sets) as needed.
- _____ Belts: Check /Tighten / Replace belts as needed.
- _____ Main Frame / Deck: Unless otherwise specified retorque bolts according to torque specifications in this section.
- _____ Hydraulic Fluid Level: Add, if required, per fluid recommendations.
- _____ Rear Flail Drive, Bearing
Flange and Shaft Couplers: Grease as instructed in the detailed (if applicable) maintenance section.
- _____ Cutter Shaft and Ground Roller: Grease as instructed in the detailed maintenance section

Service performed by: _____ Date: ___ / ___ / ___ Hour
Meter: _____

Maintenance Section

** This page may be copied and used as part of the daily maintenance routine.

FORD TS 100A CAB, WOC BOOM MOWER

PARTS SECTION

PARTS ORDERING GUIDE

The following instructions are offered to help eliminate needless delay and error in processing purchase orders for the equipment in this manual.

1. The Parts Section is prepared in logical sequence and grouping of parts that belong to the basic machine featured in this manual. Part Numbers and Descriptions are given to help locate the parts and quantities required.

2. The Purchase Order must indicate the **Name and Address** of the person or organization ordering the parts, **who should be charged**, and if possible, the **serial number of the machine** for which the parts are being ordered.

3. The purchase order must clearly list the **quantity of each part**, the complete and correct **part number**, and the basic **name of the part**.

4. The manufacturer reserves the right to substitute parts where applicable.

5. Some parts may be unlisted items which are special production items not normally stocked and are subject to special handling. Request a quotation for such parts before sending a purchase order.

6. The manufacturer reserves the right to change prices without prior notice.

NOTE: When ordering replacement decals, refer to the part numbers and descriptions listed in the safety section in the front of this manual.



1000

For maximum safety and to guarantee optimum product reliability, always use genuine **Tiger** replacement parts. The use of inferior replacement parts may cause premature or catastrophic failure which could result in serious injury or death.

Direct any questions regarding parts to:

Tiger Corporation
3301 N. Louise Ave.
Sioux Falls, SD 57107
1-800-843-6849
1-605-336-7900

PARTS SECTION TABLE OF CONTENTS

SECTION	ASSEMBLY	PAGE
TRACTOR SPECIFIC PARTS:		
TRACTOR MOUNT KIT –MAIN FRAME	06101030	5-4
TRACTOR MOUNT KIT – HYD BRAKE VALVE	06101030	5-6
TRACTOR MOUNT KIT – BOOM SWIVEL	06101030	5-8
LIFT VALVE – 5SP HUSCO	06101048	5-10
LIFT VALVE BREAKDOWN	06502047	5-12
JOYSTICK AND SWITCHBOX	06101049	5-14
LIFT VALVE - JOYSTICK, 5 SP, BOOM DANFOSS	06101049	5-16
5SP DANFOSS TSA 110, 115 & 135 STD OC	06101340	5-18
MIRROR BRACKET		5-20
BOOM POLYCORBOTE SAFETY WINDOW	06490004	5-22
CANOPY, WOC	06200224	5-23
BOOM SAFETY SCREEN ASSY - WOC	06101086	5-24
EXHAUST MOUNT		5-26
WHEEL WEIGHT	06100439-005	5-27
FRONT PUMP AND GRILL GUARD - OPTIONAL	06200349	5-28
SOLENOID BRAKE VALVE ASY		5-29
SOLENOID VALVE SWITCH AND WIRING	80155	5-30
JOYSTICK SWITCH BOX AND WIRING	32731	5-31
SWITCH BOX SCHEMATIC		5-32
TROUBLE SHOOTING		5-34
HYDRAULIC - TROUBLESHOOTING GUIDE		5-36
ELECTRICAL - TROUBLESHOOTING GUIDE		5-37
COMMON PARTS SECTION:		6-1

TRACTOR MOUNT KIT - MAIN FRAME

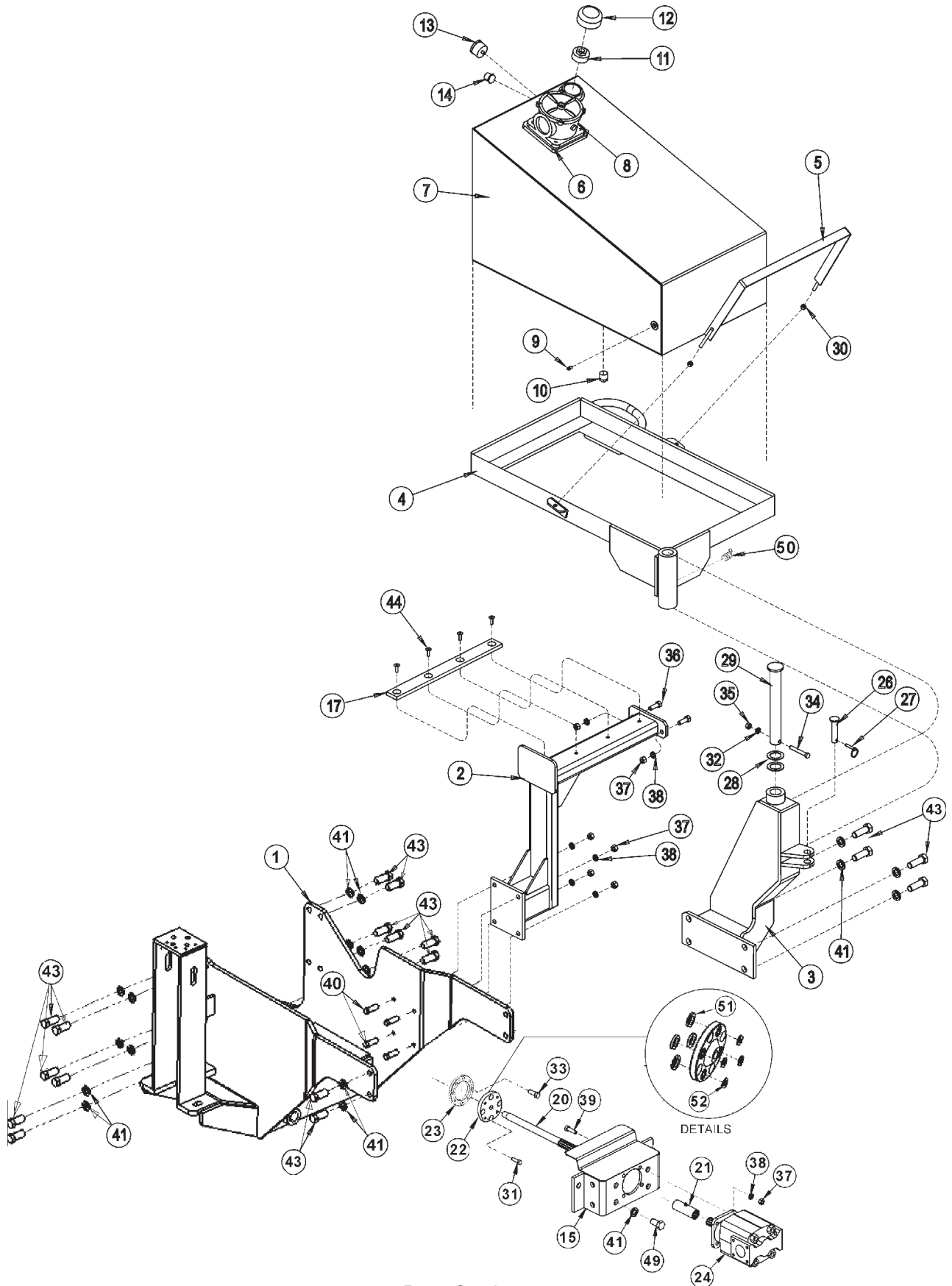

TRACTOR MOUNT KIT - MAIN FRAME

ITEM	PART NO.	QTY.	DESCRIPTION
1	06300014	1	MAIN FRAME,NHTSA100
2	06380001	1	REAR RESERVOIR SUPPORT
3	06380002	1	FRONT RESERVOIR SUPPORT
4	32667	1	RESERVOIR TANK FRAME
5	32669	1	RESERVOIR TANK STRAP
	06700006	AVAIL.	RESERVOIR TANK ASSY, TSA.
6	21627	4	NYLOCK NUTS
7	06380000	1	RESERVOIR TANK, TSA
8	35269	1	FILTER ASSY-IN TANK, JIC 10 MIC.
9	6T4197	1	PIPE PLUG
10	6T4200	1	PIPE PLUG
11	33700	1	REDUCER BUSHING
12	31004	1	TANK BREATHER
13	6T0649	1	FILTER GUAGE
14	6T1209	2	TANK SIGHT GLASS
15	32408	1	PUMP MOUNTING BRACKET
16	32690	1	SPACER - MAIN FRAME
17	32671	1	PLASTIC GUIDE
18	6T0111	8	SHIM - WHERE REQUIRED
19	6T0111A	4	SHIM - WHERE REQUIRED
20	34624	1	PUMP DRIVE SHAFT, PMP 29T
21	6T0375B	1	DRIVE SHAFT COUPLER - WITH ZERK
22	6T0389	1	CRANKSHAFT ADAPTER
23	06420006	1	CRANKSHAFT SPACER
24	23152	1	PUMP
25	32382	1	HOSE BRACKET
26	6T0107	1	TRAVEL LOCK PIN
27	RD1032	1	LYNCH PIN
28	6T2617	2	BUSHING - AS NEEDED
29	TB1025	1	PIN
30	21627	2	NYLOCK NUT - 3/8"
31	06535000	4	CAPSCREW,7/16x1 1/4,NC,CUTOFF
32	21989	2	LOCKWASHER - 7/16"
33	06530503	4	CAPSCREW,SKTHD,12MMx30MM(1.75)
34	21688	1	CAPSCREW - 7/16" X 3 1/4"
35	21675	1	HEX NUT - 7/16"
36	21731	2	CAPSCREW - 1/2" X 1 1/2"
37	21725	10	HEX NUT - 1/2"
38	21990	10	LOCKWASHER - 1/2"
39	21732	4	CAPSCREW - 1/2" X 1 3/4"
40	21733	4	CAPSCREW - 1/2" X 2"
41	24881	16	LOCKWASHER - 20MM
42	21682	1	CAPSCREW,7/16 X 1-3/4 NC
43	31731	16	CAPSCREW - 20MM X 50MM
44	28734	4	CAPSCREW - 3/8" X 1" TAPERED
45	21989	1	LOCKWASHER,7/16
46	21675	1	HEX NUT,7/16 NC
47	32703	4	CAPSCREW - 20MM X 100MM
48	TB3012	1	HOSE BRACKET
49	24860	6	CAPSCREW - 20MM X 40MM
50	6T3208	1	GREASE ZERK, 1/8 X 45
51	06537004	4	WASHER,NEOPRENE,.75x1.25x.19
52	24937	4	F LAT WASHER
*	33895	AVAIL	KIT CRANK SHAFT (INCLUDES ITEMS 20,21,22)

TRACTOR MOUNT KIT - HYDRAULICS, BRAKE VALVE

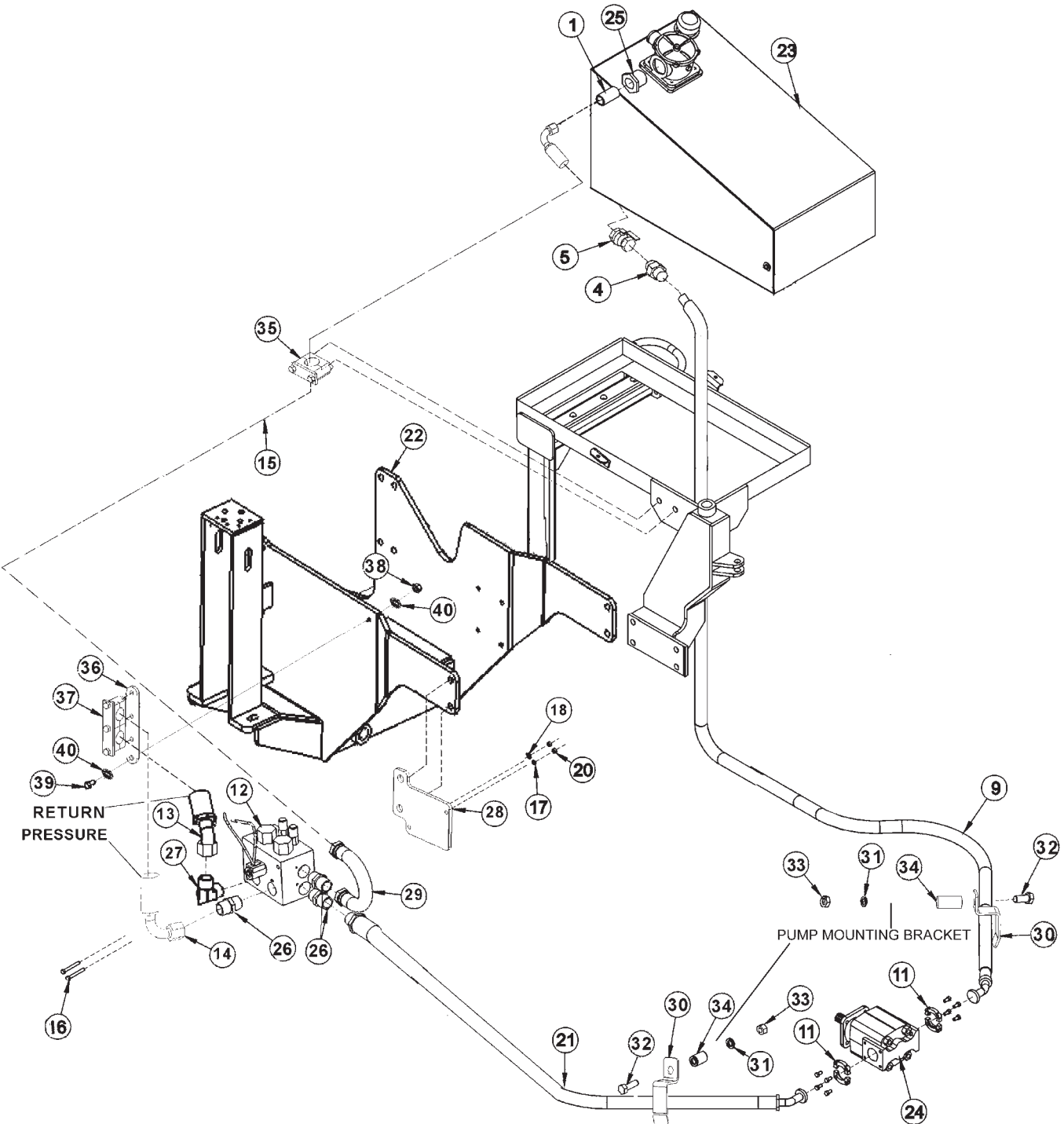

06101030 HYDRAULICS
06101033 HYDRAULICS

TRACTOR MOUNT KIT - HYDRAULICS, BRAKE VALVE

ITEM	PART NO.	QTY.	DESCRIPTION
1	32869	1	NIPPLE,MALE LONG,1MOR X 1MJ
4	34067	1	ADAPTER,1 1/4MORX1 1/4MJ
5	34069	1	BALL VALVE,1 1/4FOR
7	23568	4	HOSE CLAMP (NOT SHOWN)
8	6T3200	3	SPLIT HOSE (NOT SHOWN)
9	06500065	1	HOSE,1 1/4x55(1 1/4FJXx20FLG45)
11	TF4852	2	#20 FLANGE KIT
12	34115	1	SOLENOID BRAKE VALVE
13	06500071	1	HOSE,1X93(1FJX90x1FJX)
14	06500070	1	HOSE,1x82(1FJX45x1FJX)
15	34311	1	HOSE,1x125 (1MJx1FJx90)
16	21644	2	CAPSCREW - 3/8" X 5"
17	6T2665	1	STAR LOCKWASHER - 3/8"
18	21988	1	LOCKWASHER - 3/8"
19	22016	2	FLATWASHER - 3/8"
20	21625	2	HEX NUT - 3/8"
21	06500066	1	HOSE,1x37(1FJXx20FLG45)
22	*	REF.	MAIN FRAME - REFER TO MAIN FRAME PARTS
23	*	REF.	RESERVOIR TANK - REFER TO MAIN FRAME PARTS
24	*	REF.	FRONT PUMP - REFER TO MAIN FRAME PARTS
25	33424	1	ADAPTER,1 1/4MORB X 1FOR, LONG
26	33555	3	ADAPTER,1MORBx1MJIC
27	34117	1	ELBOW,1MOR X 1MJ90, FORGED
28	06400114	1	MNT,BRAVE VALVE
29	06506012	1	PRFRMD,BRKVLV,4x1FJXx1FJX(180)
30	32382	2	BRACKET,HOSE
31	24881	2	LOCKWASHER,2OMM
32	24860	2	CAPSCREW,20MMX40MM(2.5 PITCH)
34	34048	2	SPACER,2.25X1.25X.813
35	06505017	1	CLAMP KIT,1 HOSE,1"
36	35271	1	CLAMP PLATE,MID
37	35131	1	CLAMP KIT,COOLER,TRUCKAT
38	21675	1	HEX NUT,7/16 NC
39	21682	1	CAPSCREW,7/16 X 1-3/4 NC
40	21989	1	LOCKWASHER,7/16

TRACTOR MOUNT KIT - BOOM SWIVEL, CAB/WOC

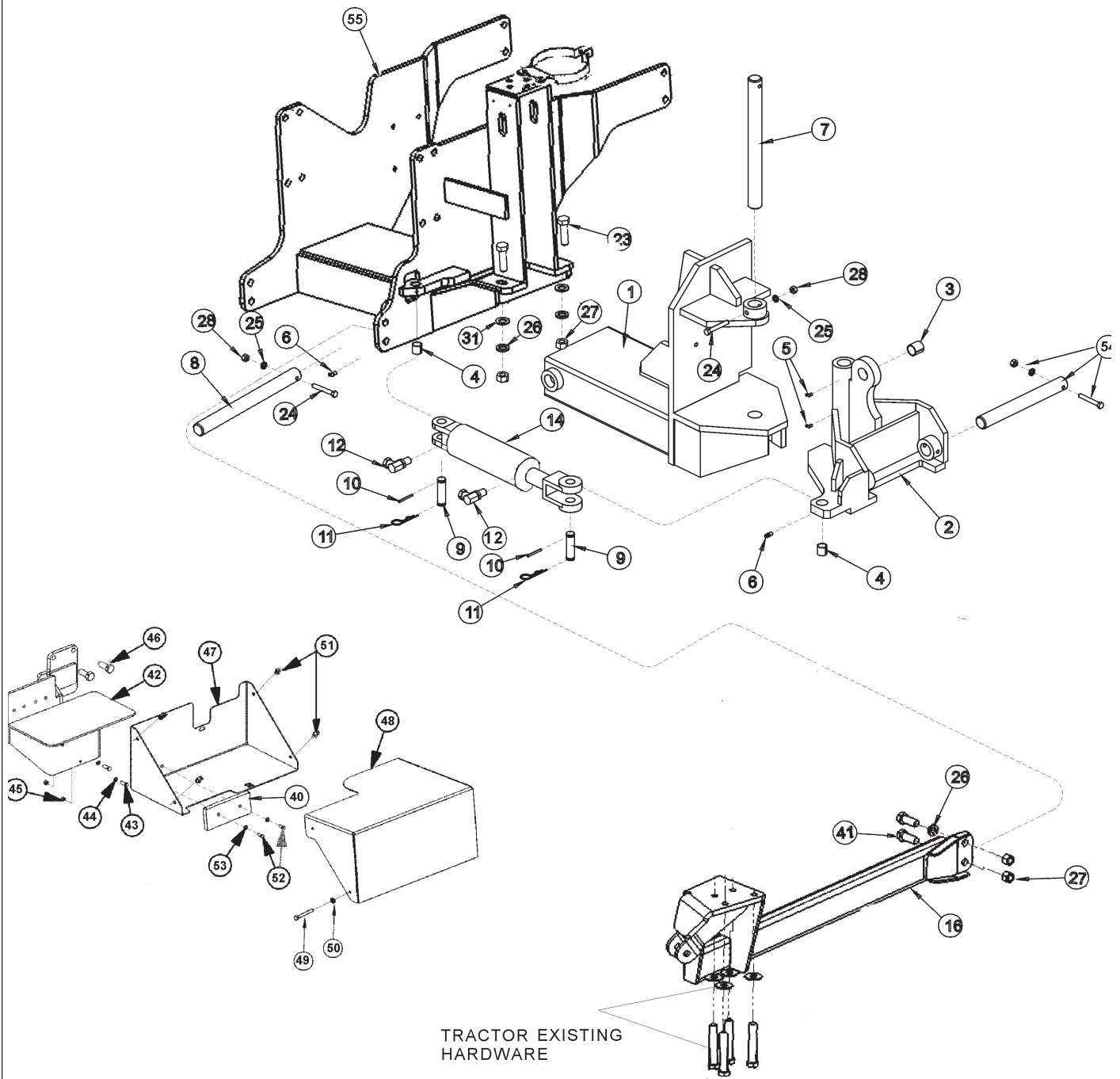

TRACTOR MOUNT KIT - BOOM SWIVEL, CAB/WOC

ITEM	PART NO.	QTY.	DESCRIPTION
1	TB3001C TB3002B	1 AVAIL.	BOOM MOUNTING BRACKET BOOM SWIVEL ASSEMBLY
2	24514B	1	BOOM SWIVEL BRACKET
3	33466	1	BUSHING
4	TB3010	1	BUSHING
5	6T3210	2	GREASE ZERK - 90 DEG
6	6T3207	1	GREASE ZERK
7	TB3014	1	SWIVEL PIN
8	6T3001	1	INNER DRAFT BEAM PIN
9	6T3003D	2	CLEVIS PIN
10	TB1023	2	ROLL PIN
11	6T3004	2	R-CLIP
12	32810	2	ELBOW,1/2ORBX3/8MJ 90 ADJ
14	06501021	1	CYLINDER WELDED- BOOM SWIVEL
15	6T3208	1	GREASE ZERK - 45 DEG
16	06300011	1	AXLE BRACE, RH NHTSA115
16A	06300012	1	AXLE BRACE, LH NHTSA115
18	06370007	1	BATT MNT,TSA
23	21835	2	CAPSCREW - 3/4" X 2 3/4"
24	21688	2	CAPSCREW - 7/16" X 3 1/4"
25	21989	2	LOCKWASHER - 7/16"
26	21993	8	LOCKWASHER - 3/4"
27	21825	6	HEX NUT - 3/4"
28	21675	2	HEX NUT - 7/16"
31	22021	8	FLATWASHER - 3/4"
32	TB3010	1	BUSHING
33	21525	2	HEX NUT - 1/4"
34	21986	2	LOCKWASHER - 1/4"
35	21529	2	CAPSCREW - 1/4" X 3/4"
36	21629	4	CAPSCREW - 3/8" X 3/4"
37	21988	4	LOCKWASHER - 3/8"
38	27947	2	SPACER - BATTERY BOX
39	21837	2	CAPSCREW - 3/4" X 3 1/4"
41	21833	2	CAPSCREW - 3/4" X 2 1/4"
42	06370011	1	BATT MNT, TS 100-135A
43	21580	2	CAPSCREW - 5/16" X 1" NC
44	21987	2	LOCKWASHER - 5/16"
45	21575	2	HEX NUT,5/16 NC
46	*	2	EXISTING HARDWARE
47	06410146	1	COVER,BOT, BATT, TS 100-135A
48	06410145	1	COVER, TOP, BATT, TS 100-135A
49	21529	4	CAPSCREW - 1/4" X 3/4" NC
50	21986	4	LOCKWASHER - 1/4"
51	35176	4	U NUT 1/4" X 3/4"
52	21629	2	CAPSCREW - 3/8" X 3/4" NC
53	21988	2	LOCKWASHER - 3/8"
54	*	REF.	PIN / CS / LW - REFER TO BOOM ARM PARTS
55	*	REF.	MAIN FRAME - REFER TO MAIN FRAME PARTS

LIFT VALVE - 5SP HUSCO

HOSE ROUTING

- A - TO SAFETY SHIELD CYLINDER BUTT
- B - TO SAFETY SHIELD CYLINDER GLAND
- C - TO SWIVEL CYLINDER BUTT
- D - TO SWIVEL CYLINDER GLAND
- E - TO DECK ROLL CYLINDER GLAND
- F - TO DECK ROLL CYLINDER BUTT
- G - TO SECONDARY CYLINDER GLAND
- H - TO SECONDARY CYLINDER BUTT
- J - TO ACCUMULATOR
- K - TO MAIN BOOM CYLINDER BUTT
- L - TO MAIN BOOM CYLINDER GLAND

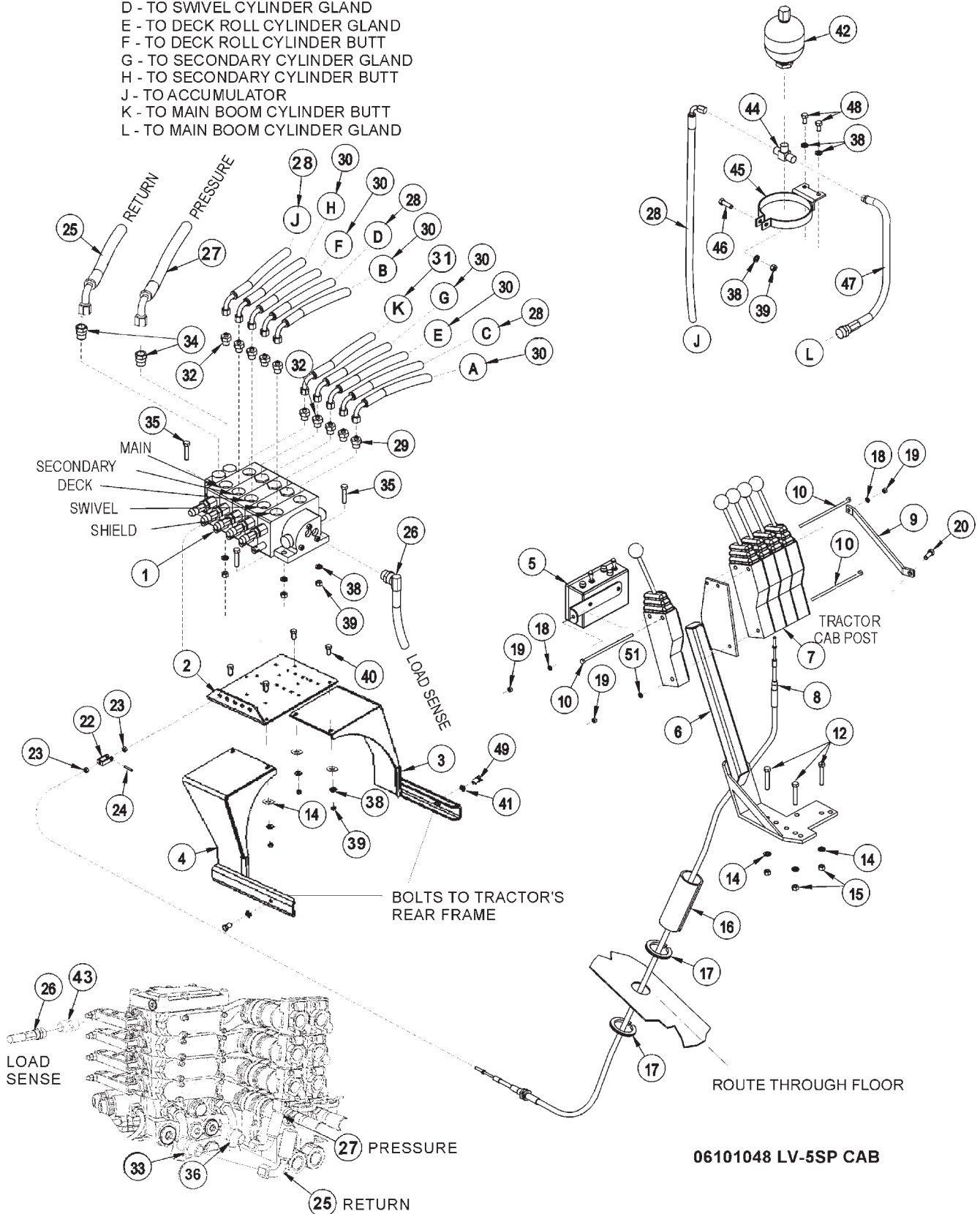

06101048 LV-5SP CAB

LIFT VALVE - 5SP HUSCO

ITEM	PART NO.	QTY.	DESCRIPTION
1	06502047	1	VALVE,5SP,HSC2,TRB,LS
2	34622	1	VALVE MOUNTING PLATE
3	06340008	1	VALVE MOUNTING ANGLE, LF
4	06340009	1	VALVE MOUNTING ANGLE, RF
5	34523	1	SWITCH BOX, BOOM
6	23865B	1	CABLE CONTROL MOUNTING BRACKET
7	6T1251	5	CABLE CONTROL BOX
8	34623	5	CONTROL CABLE 122"
9	30750A	1	SUPPORT BRACKET
10	34332	3	CAPSCREW 1/4" X 9 1/2"
11	22014	1	CAPSCREW 1/4" X 9"
12	21635	3	CAPSCREW 3/8" X 2 1/4"
14	22016	3	FLATWASHER 3/8"
15	21627	3	NYLOCK NUT 3/8"
16	6T3200	1	SPLIT HOSE 6" LONG
17	TB3440	8"	TRIMLOCK
18	21986	8	LOCKWASHER 1/4"
19	21525	3	HEX NUT 1/4"
20	23113	1	CAPSCREW 10MM X 30MM (1.5 PITCH)
22	6T4411	5	CABLE CLEVIS
23	21500	10	HEX NUT 1/4" UNF
24	6T3017	5	ROLL PIN
25	06500063	1	HOSE,1/2x30(3/4FJX90x1/2FJX90L)195deg(RETURN)
26	06500064	1	HOSE,1/4x18(3/8ORB90x5/16FJX) (LOAD SENSE)
27	06500062	1	HOSE,1/2x30(1/2FJX90 x 1/2FJX90L) 195 (PRESSURE)
28	34632	3	HOSE,1/4x115(3/8FJXx3/8FJX90)
29	33271	8	ADAPTER,1/2 MOR X 3/8 MJ
30	06500060	6	HOSE,1/4x142(5/16MJx3/8FJX90)
31	06500061	1	HOSE,1/4x166(3/8FJXx3/8FJX90)
32	06502036	2	CHECK VALVE
33	06503012	1	ADPTR,27MMORBx3/4MJ
34	06503011	1	ADAPTER,5/8ORBx1/2MJ
35	21631	2	CAPSCREW,3/8 X 1-1/4 NC
36	33463	1	ADAPTER
37	21631	2	CAPSCREW 3/8" X 1-1/4"
38	21988	11	LOCKWASHER 3/8"
39	21627	9	HEX NUT 3/8"
40	21630	4	CAPSCREW 3/8" X 1"
41	21990	2	LOCKWASHER 1/2
43	06503002	1	ADAPTER,12MMORBx5/16MJ
42	24300	1	ACCUMULATOR
44	34020	1	TEE BRANCH
45	23888	1	ACCUMULATOR BRACKET
46	21633	1	CAPSCREW 3/8" X 1 3/4"
47	34053	1	HOSE,1/4X55(3/8FJX x 3/8FJX)
48	21629	2	CAPSCREW 3/8" X 3/4"
49	21729	2	CAPSCREW 1/2" X 1" NC
50	22016	4	FLATWASHER 3/8"
**	34618	38"	HOSE SLEEVE (NOT SHOWN)

LIFT VALVE - 5SP, LOAD SENSE (06502047)

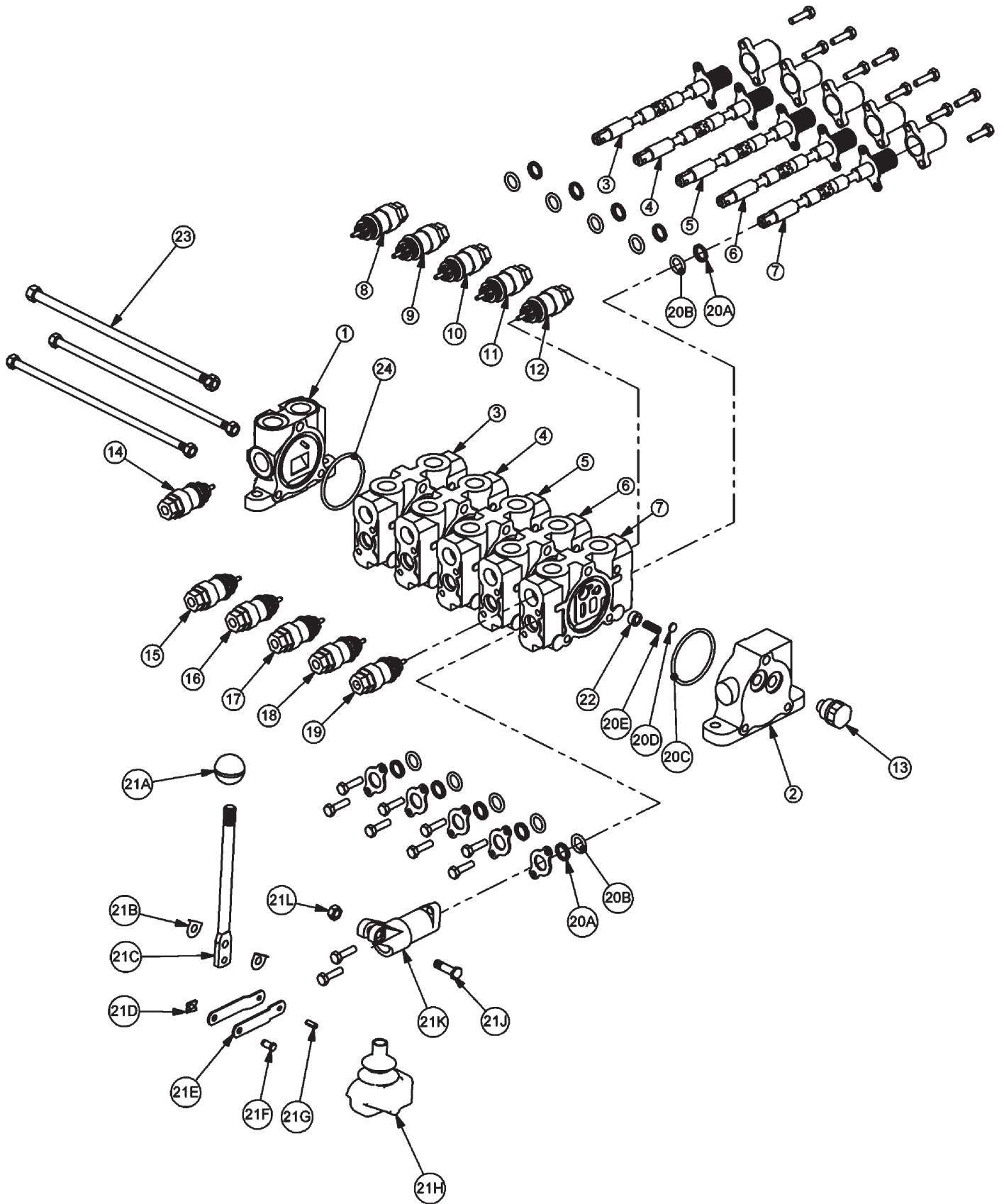

LIFT VALVE - 5SP, LOAD SENSE (06502047)

ITEM	PART NO.	QTY	DESCRIPTION
1	31595	1	INLET END COVER
2	31594	1	END COVER, LOAD SENSE
3	31597	1	VALVE SECTION (DOUBLE ACTING, CENTER SPRING)
4	31597	1	VALVE SECTION (DOUBLE ACTING, CENTER SPRING)
5	31597	1	VALVE SECTION (DOUBLE ACTING, CENTER SPRING)
6	31598	1	VALVE SECTION (DOUBLEACTING, CENTER SPRING, METERED)
7	31597	1	VALVE SECTION (DOUBLE ACTING, CENTER SPRING) (REMOVE SHUTTLE DISC)
8	06503067	1	#10 O-RING PLUG
9	TB1017K	1	RELIEF VALVE, 2150 PSI
10	TB1017J	1	RELIEF VALVE, 1800 PSI
11	TB1017H	1	RELIEF VALVE, 1750 PSI
12	22588	1	RELIEF VALVE, 500 PSI
13	06503068	1	#6 O-RING PLUG
14	6T4209	1	#10 O-RING PLUG
15	06502003	1	RELIEF VALVE, 2500 PSI
16	TB1017F	1	RELIEF VALVE, 1500 PSI
17	TB1017F	1	RELIEF VALVE, 1500 PSI
18	TB1017H	1	RELIEF VALVE, 1750 PSI
19	22588	1	RELIEF VALVE, 500 PSI
20	31593	5	VALVE SEAL KIT (FOR ONE SECTION)
20A		2	WIPER
20B		2	O-RING SMALL
20C		1	O-RING LARGE
20D		1	SHUTTLE DISC
20E		1	SPRING
21	TB1017L	5	LEVER KIT (FOR ONE SECTION)
21A		1	LEVER KNOB
21B		1	LEVER
21C		2	LEVER WASHER
21D		1	LEVER CLIP
21E		2	LINKAGE
21F		1	LEVER PIN
21G		1	ROLL PIN
21H		1	LEVER BOOT
21J		1	LEVER BOLT
21K		1	LEVER DUST COVER
21L		1	LEVER NUT
22	31603	5	COMPENSATOR
23	TB1017V	1	TIE ROD KIT
24	24214	1	O-RING, LARGE

JOYSTICK AND SWITCH BOX

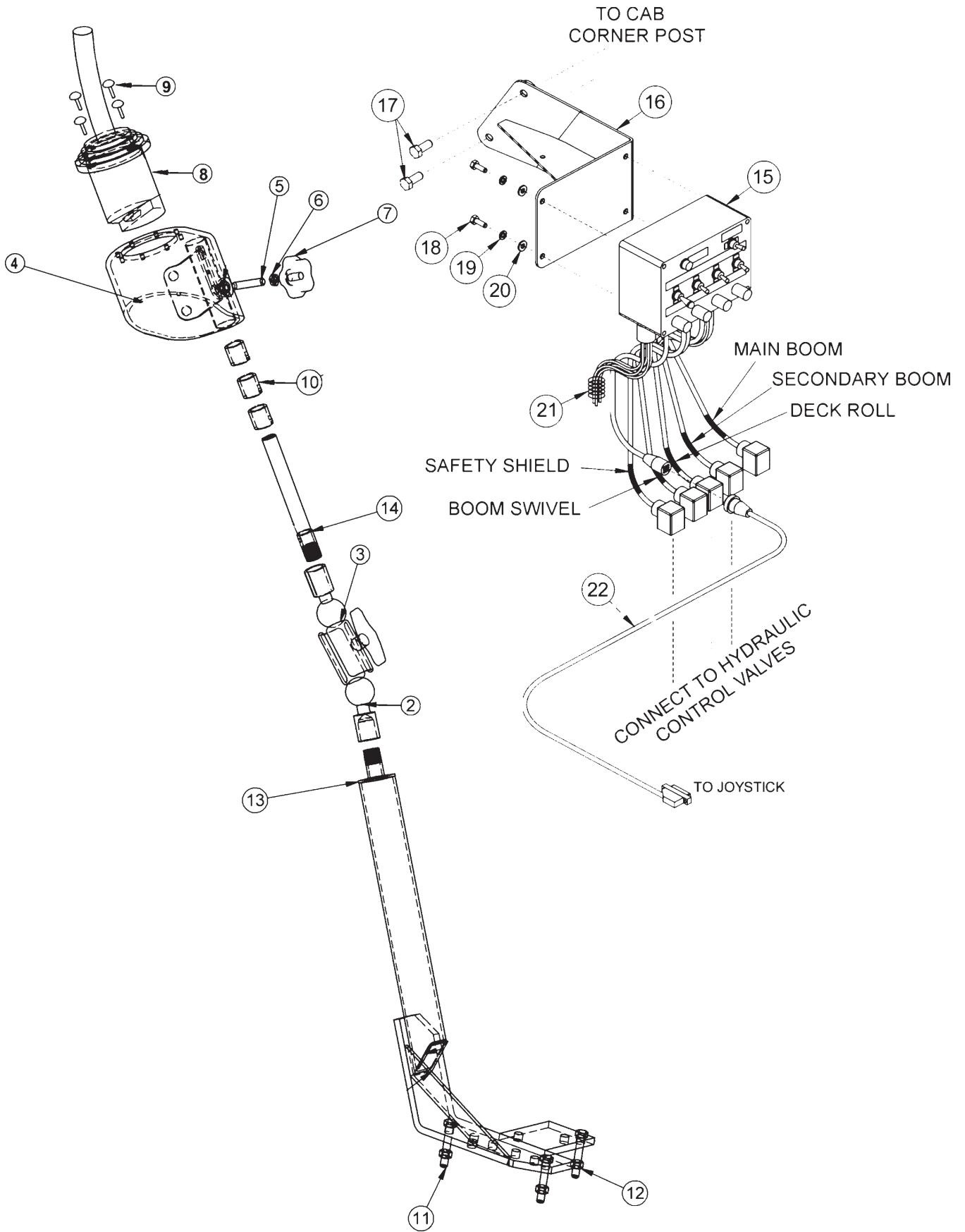

JOYSTICK AND SWITCH BOX

ITEM	PART NO.	QTY.	DESCRIPTION
2	06520041	2	MOUNT, RAM, BALL, 1 1/2", 2181
3	06520042	1	MOUNT, RAM, ARM, 1.5"x2.75", 201-B
4	35033	1	CAN, JYSTK, CPLT, TRUCKAT
5	35205	1	SETSCREW, 3/8 x 2 NC, KNURLED PT
6	35206	1	HEX NUT, JAMB, 3/8 NC
7	35204	1	KNOB, 3/8 NC, INSERT
8	33691	1	JOYST, 4AXIS, RH, DF, W/SUB-D CONN
9	32829	4	SCREW, MACHINE, 10-32X3/4, FLATHD
10	35256	3	BUSHING, NYLON, 1"OD, 3/4"ID
11	21635	3	CAPSCREW, 3/8 X 2-1/4 NC
12	21627	3	NYLOCK NUT, 3/8 NC
13	06340011	1	MNT, STND, JYSTK, TS115A
14	06340010	1	ROD, 1/2NPTx7, JYSTK
15	32498	1	SWITCHBOX
16	33355	1	SWITCHBOX MOUNTING BRACKET
17	27513	2	CAPSCREW 10MM X 25MM
18	21529	4	CAPSCREW 1/4" X 3/4" NC
19	21986	4	LOCKWASHER 1/4"
20	22014	4	LOCKWASHER 1/4"
21	PT3905E	10'	WIRE WRAP 1/2"
22	33693	1	CABLE - JOYSTICK 4'
*	33518	1	FUSE - 10AMP (NOT SHOWN)
*	33742	10'	WIRE WRAP - 1" (NOT SHOWN)

LIFT VALVE - JOYSTICK, 5 SP, BOOM DANFOSS

HOSE ROUTING

- A - TO ACCUMULATOR
- B - TO SECONDARY CYLINDER GLAND
- C - TO DECK ROLL CYLINDER GLAND
- D - TO BOOM SWIVEL CYLINDER GLAND
- E - TO SAFETY SHIELD CYLINDER GLAND
- F - TO MAIN BOOM CYLINDER BUTT
- H - TO SECONDARY BOOM CYLINDER BUTT
- J - TO DECK ROLL CYLINDER BUTT
- K - TO BOOM SWIVEL CYLINDER BUTT
- L - TO SAFETY SHIELD CYLINDER BUTT
- M - TO MAIN BOOM CYLINDER GLAND

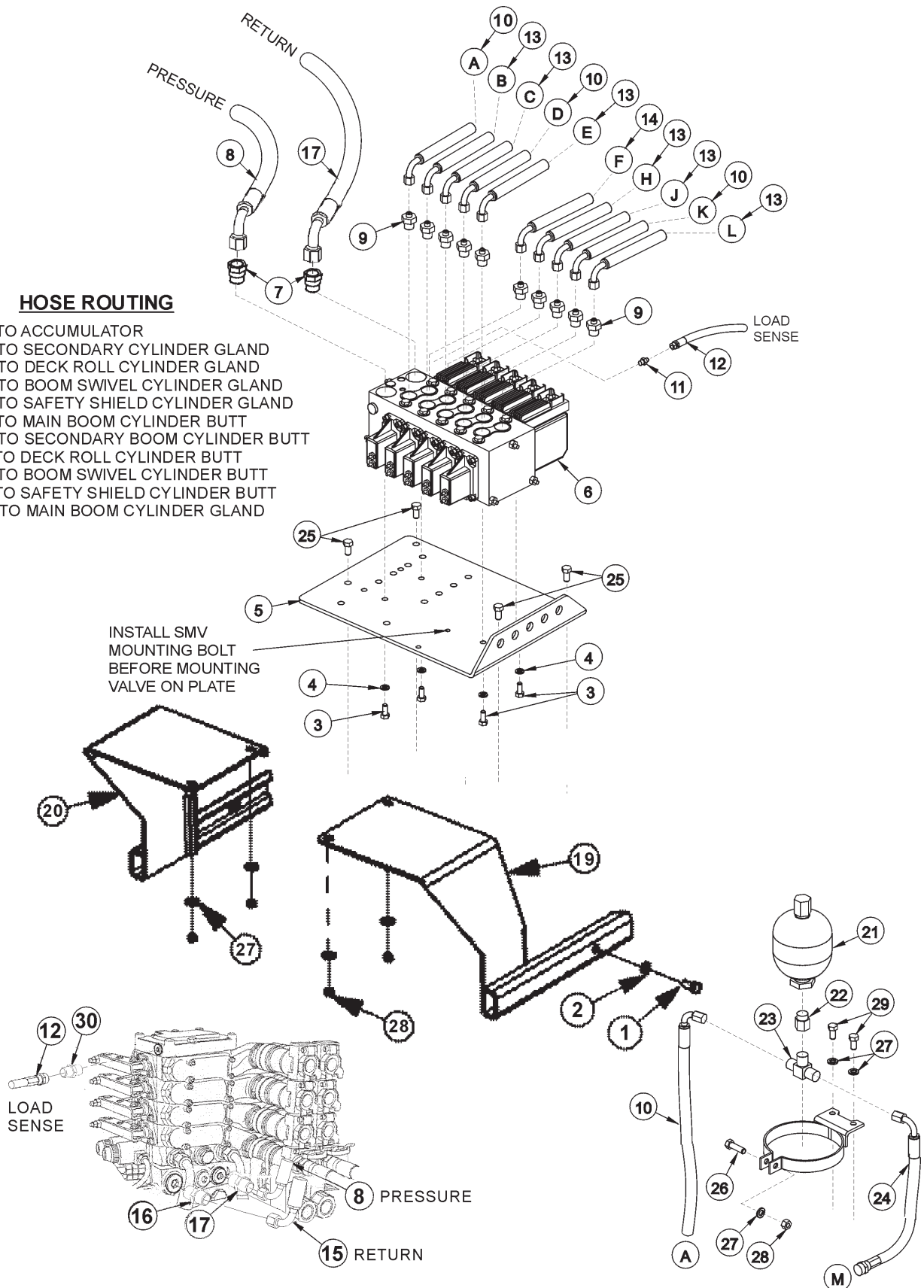

LIFT VALVE - JOYSTICK, 5 SPOOL, BOOM DANFOSS

ITEM	PART NO.	QTY	DESCRIPTION
1	21729	2	CAPSCREW,1/2 X 1 NC
2	21990	2	LOCKWASHER,1/2
3	21579	4	CAPSCREW - 5/16" X 3/4"
4	21987	4	LOCKWASHER - 5/16"
5	34622	1	VALVE MOUNTING PLATE
6	06502096	1	ELECTRONIC LIFT VALVE - 5 SPOOL
7	33591	2	ADAPTER,3/4MORX1/2MJ
8	06500062	1	HOSE,1/2x30(1/2FJX90 x 1/2FJX90L) 195 (PRESSURE)
9	32807	10	ADAPTER
10	34632	3	HOSE, 1/4x115(3/8FJXx3/8FJX90)
11	33419	1	ADAPTER
12	06500092	1	HOSE,1/4
13	06500060	6	HOSE,1/4x142(5/16MJx3/8FJX90)
14	06500061	1	HOSE,1/4x166(3/8FJXx3/8FJX90)
15	33463	1	ADAPTER,22mm ORB x 1/2MJ
16	06503012	2	ADPTR,27MMORBx3/4MJ
17	06500091	1	HOSE,1/2x26(3/4FJX90x 1/2FJX90L)190
19	06340008	1	VLV MNT,RH,TSA115
20	06340009	1	VLV MNT,LH,TSA115
21	24300	1	ACCUMULATOR
22	28917	1	ADAPTER
23	34020	1	TEE,BRANCH,3/8MJX1/2ORBx3/8MJ
24	33397	1	HOSE
25	21630	4	CAPSCREW 3/8" X 1"
26	21633	1	CAPSCREW 3/8" X 1 3/4"
27	21988	7	LOCKWASHER 3/8"
28	21625	5	HEX NUT 3/8"
29	21629	2	CAPSCREW 3/8" X 3/4"
30	0653002	1	ADAPTER,12MM ORBx5/16MJ

5SP DANFOSS TSA 110,115 & 135 STD OPEN CENTER

HOSE ROUTING

- A - DANFOSS TO ACCUMULATOR
- B - TO SECONDARY CYLINDER GLAND
- C - TO DECK ROLL CYLINDER GLAND
- D - TO BOOM SWIVEL CYLINDER GLAND
- E - TO SAFETY SHIELD CYLINDER GLAND
- F - TO MAIN BOOM CYLINDER BUTT
- G - TO SECONDARY BOOM CYLINDER BUTT
- H - TO DECK ROLL CYLINDER BUTT
- J - TO BOOM SWIVEL CYLINDER BUTT
- K - TO SAFETY SHIELD CYLINDER BUTT
- L - TO MAIN BOOM CYLINDER GLAND
- M - LOAD SENSE LINE
- N - PRESSURE BETWEEN VALVES
- O - RETURN DANFOSS TO TRACTOR
- T - RETURN, PRIORITY VALVE TO TRACTOR
- U - PRESSURE, FILTER TO PRIORITY VALVE
- V - PRESSURE, TRACTOR TO FILTER

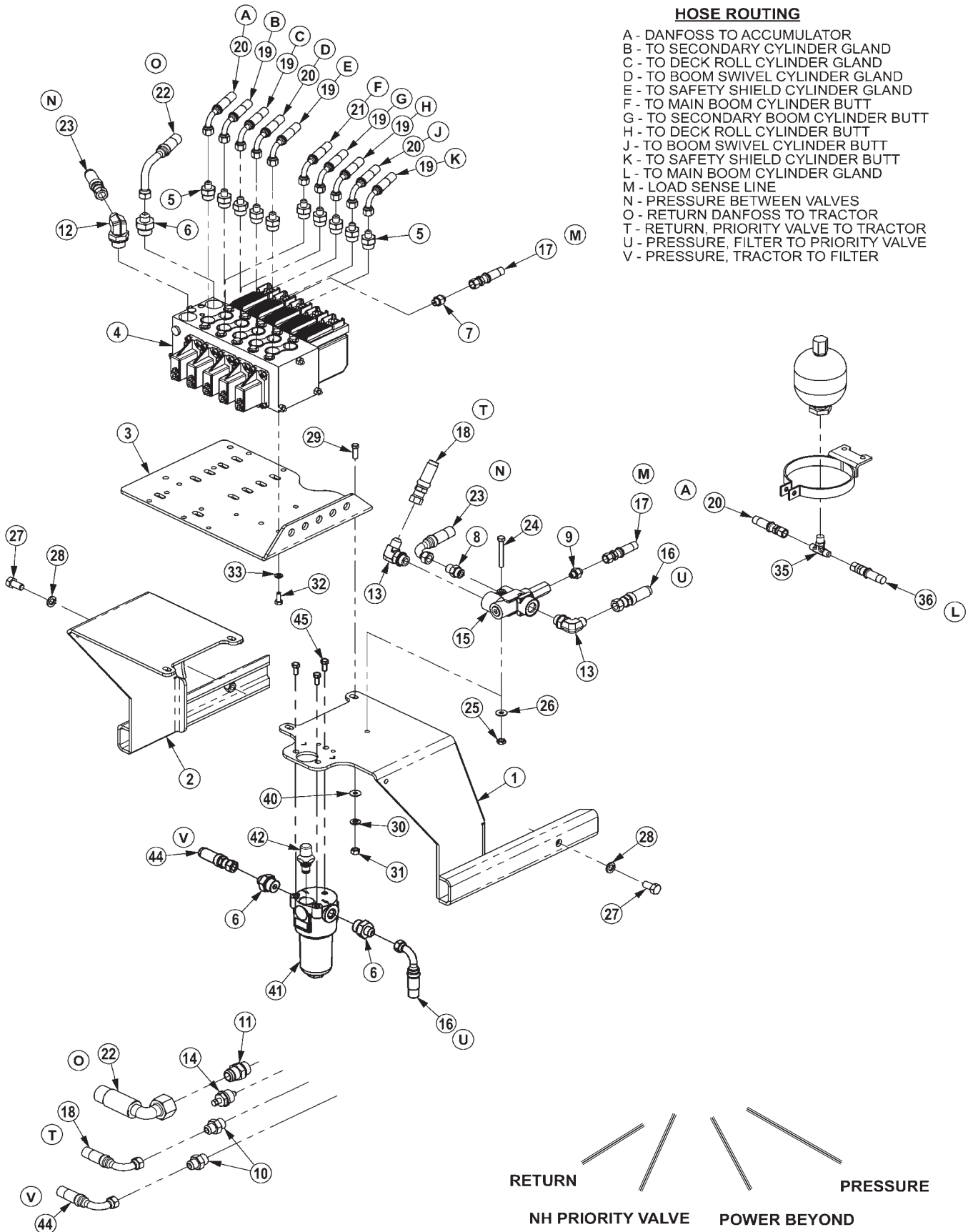

5SP DANFOSS TSA 110,115 & 135 STD OPEN CENTER

ITEM	PART NO.	QTY.	DESCRIPTION
1	06340008	1	VLV MNT,RH,TSA115
2	06340009	1	VLV MNT,LH,TSA115
3	34622	1	PLATE,VALVE,REAR MNT
4	06502096	1	VALVE,5SP,SBF,EHP,DANFOSS PVG
5	32807	10	ADAPTER,5/8MORB X 3/8MJ
6	33591	1	ADAPTER,3/4MORX1/2MJ
7	33392	1	ADAPTER,5/16MORB X 3/8MJ
8	33528	1	ADAPTER,1/2MORBX1/2MJIC
9	06503057	1	ADAPTER,1/4ORBx3/8MJ
10	33463	2	ADAPTER,22mm ORB x 1/2MJ
11	06503012	1	ADPTR,27MMORBx3/4MJ
12	33294	1	ELBOW,3/4MOR X 1/2MJIC 90
13	33383	2	ELBOW,5/8MORB X 1/2MJ X 90
14	F87372883	1	VALVE,PRIORITY,PB,NH
15	06502102	1	VALVE,PRIORITY,OLS-80,DANFOSS,
16	06500255	1	HOSE, 1/2x30(1/2FJXx1/2FJX90L)
17	06500219	1	HOSE,3/8x48
18	06500203	1	HOSE,1/2x30(1/2FJXx1/2FJX90)
19	06500060	6	HOSE,1/4x142(5/16MJx3/8FJX90)
20	34632	3	HOSE,1/4x115(3/8FJXx3/8FJX90)
21	06500061	1	HOSE,1/4x166(3/8FJXx3/8FJX90)
22	06500063	1	HOSE,1/2x30(3/4FJX90x1/2FJX90L) 195
23	34612	1	HOSE,1/2X34(1/2FJXX1/2FJX90)
24	21586	1	CAPSCREW,5/16 X 2-1/2 NC
25	21577	1	NYLOCK NUT,5/16 NC
26	22015	1	FLATWASHER,5/16
27	21729	2	CAPSCREW,1/2 X 1 NC
28	21990	2	LOCKWASHER,1/2
29	21630	4	CAPSCREW,3/8 X 1 NC
30	21988	7	LOCKWASHER,3/8
31	21625	5	HEX NUT,3/8 NC
32	21579	4	CAPSCREW,5/16 X 3/4 NC
33	21987	4	LOCKWASHER,5/16
34	24300	1	ACCUMULATOR
35	34020	1	TEE,BRANCH,3/8MJX1/2ORBx3/8MJ
36	33397	1	HOSE,1/4X55(3/8FJXX3/8FJX)
37	21633	1	CAPSCREW 3/8" X 1 3/4"
38	21629	2	CAPSCREW 3/8" X 3/4"
39	23888	1	BRKT,ACCUMULATOR

MIRROR BRACKET

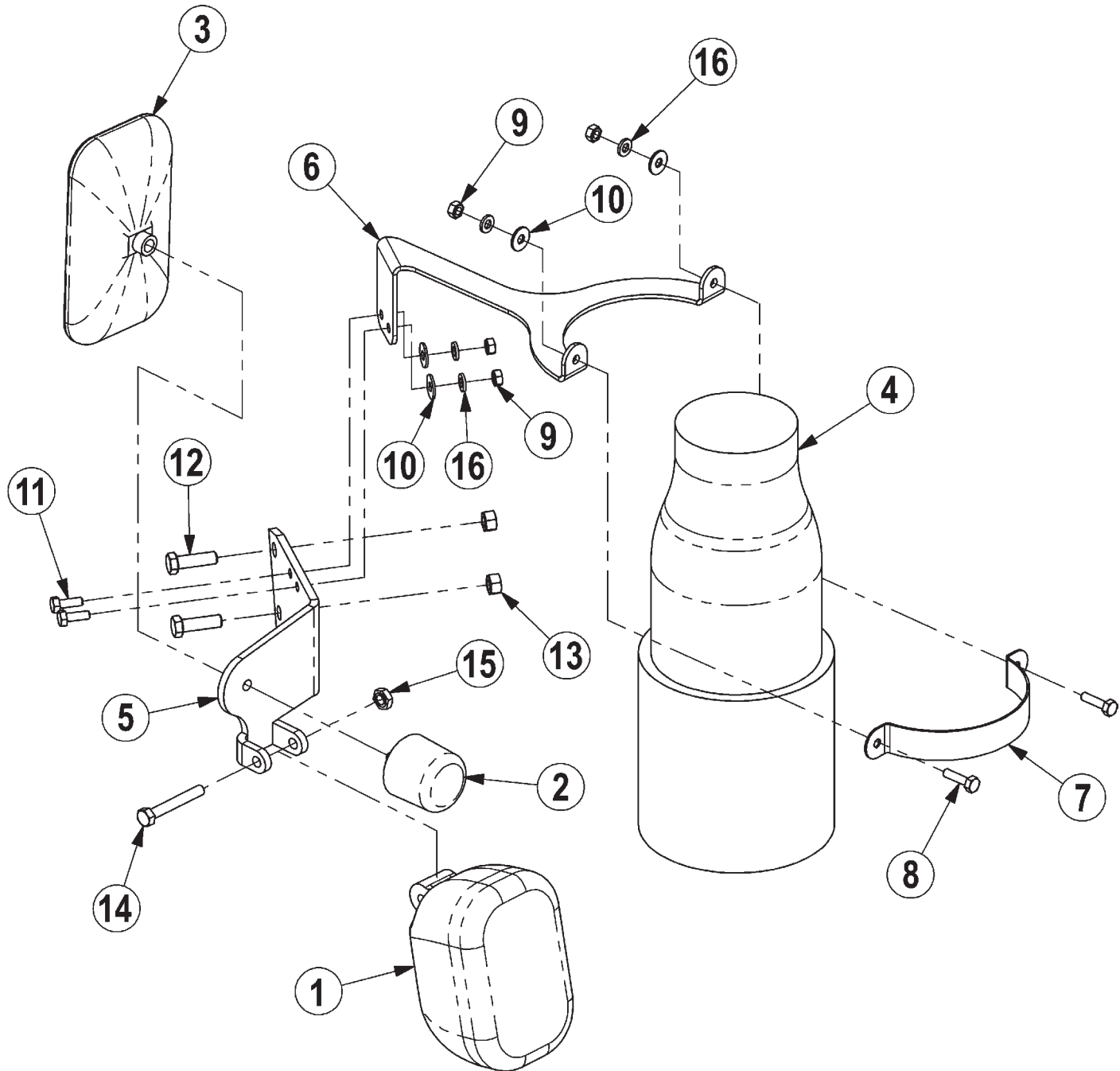

MIRROR BRACKET

ITEM	PART NO.	QTY.	DESCRIPTION
1	*	1	WORK LIGHT (EXISTING)
2	*	1	MIRROR KNOB (EXISTING)
3	*	1	MIRROR (EXISTING)
4	*	1	EXHAUST MUFFLER (EXISTING)
5	06370008	1	MNT,MIRROR/LIGHT,TS115A
6	06410141	1	COLLAR,EXHAUST,TS115A
7	06410142	1	COLLAR,CLAMP,EXHAUST,TS115A
8	21530	2	CAPSCREW,1/4 X 1 NC
9	21525	4	HEX NUT,1/4 NC
10	22014	4	FLATWASHER,1/4
11	21529	2	CAPSCREW,1/4 X 3/4 NC
12	21631	2	CAPSCREW,3/8" X 1 1/4" NC
13	21627	2	NYLOCK,3/8" NC
14	21585	1	CAPSCREW, 5/16" X 2 1/4" NC
15	21529	1	NYLOCK, 5/16" NC
16	21986	4	LOCKWASHER,1/4

BOOM POLYCARBONATE CAB SAFETY WINDOW KIT

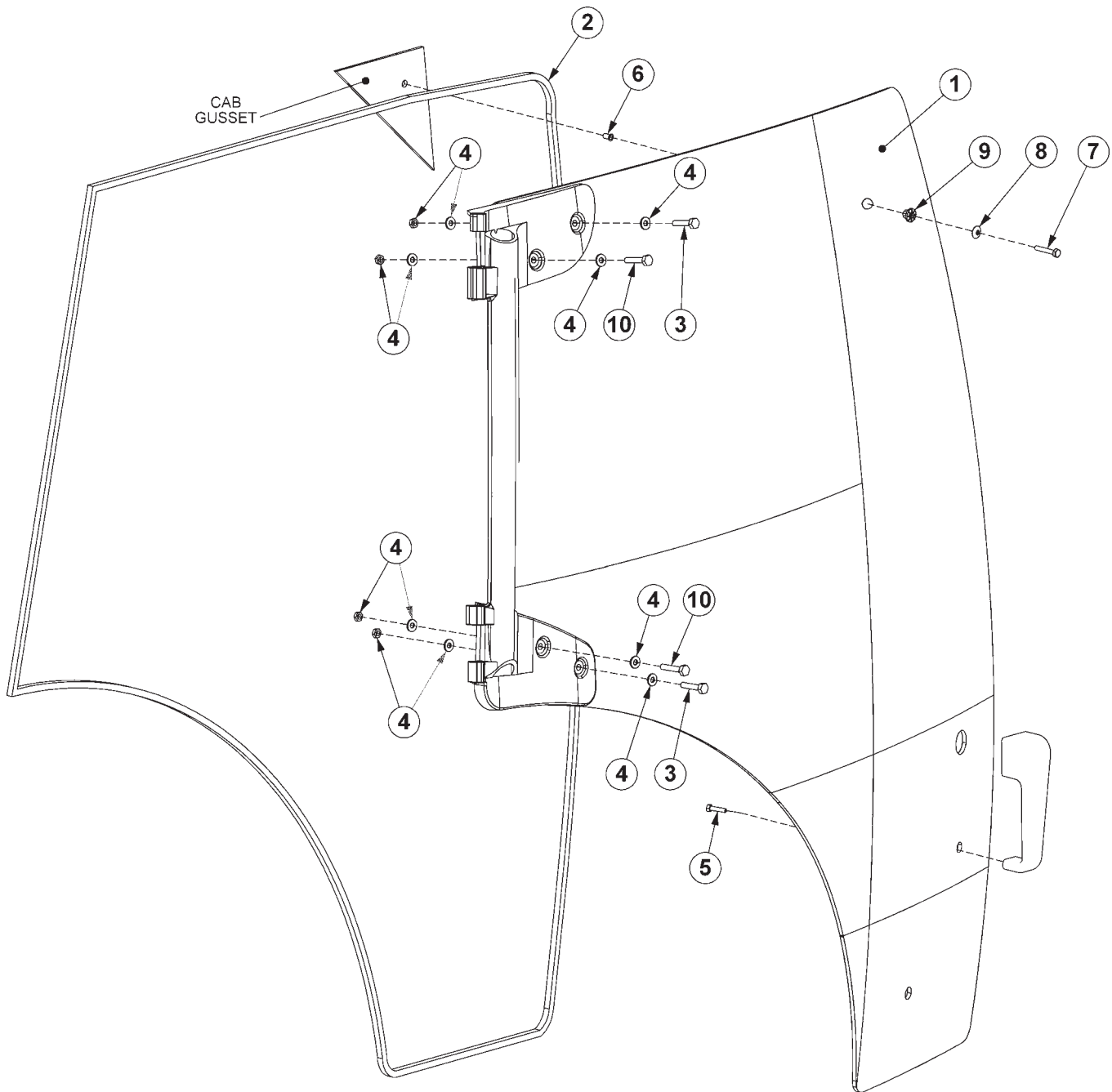

ITEM	PART NO.	QTY.	DESCRIPTION
1	06490004	1	POLYCARBONATE, NHTSA 115, DOOR, RH
2	31965	17'	TRIM SEAL, 3/8 CLIP X 3/4 OD BULB
3	06530502	2	CAPSCREW 8 MM X 40 MM GR8
4	*	*	EXISTING HARDWARE
5	06530501	1	CAPSCREW 6 MM X 25 MM GR8
6	06537006	1	THREADED INSERT 1/4 X 1/2 NC
7	21532	1	CAPSCREW, 1/4X1-1/2 NC
8	06537001	1	WASHER RUBBERIZED
9	35234	1	GROMET, RIBBED 1/2 OD X 1/4 ID X 1/2
10	6T2494	2	CAPSCREW 8 MM X 45 MM GR8
*	06537005	1	ADHESIVE, WTHR STRP (NOT SHOWN)

NON-CAB STEEL CANOPY - OPTIONAL

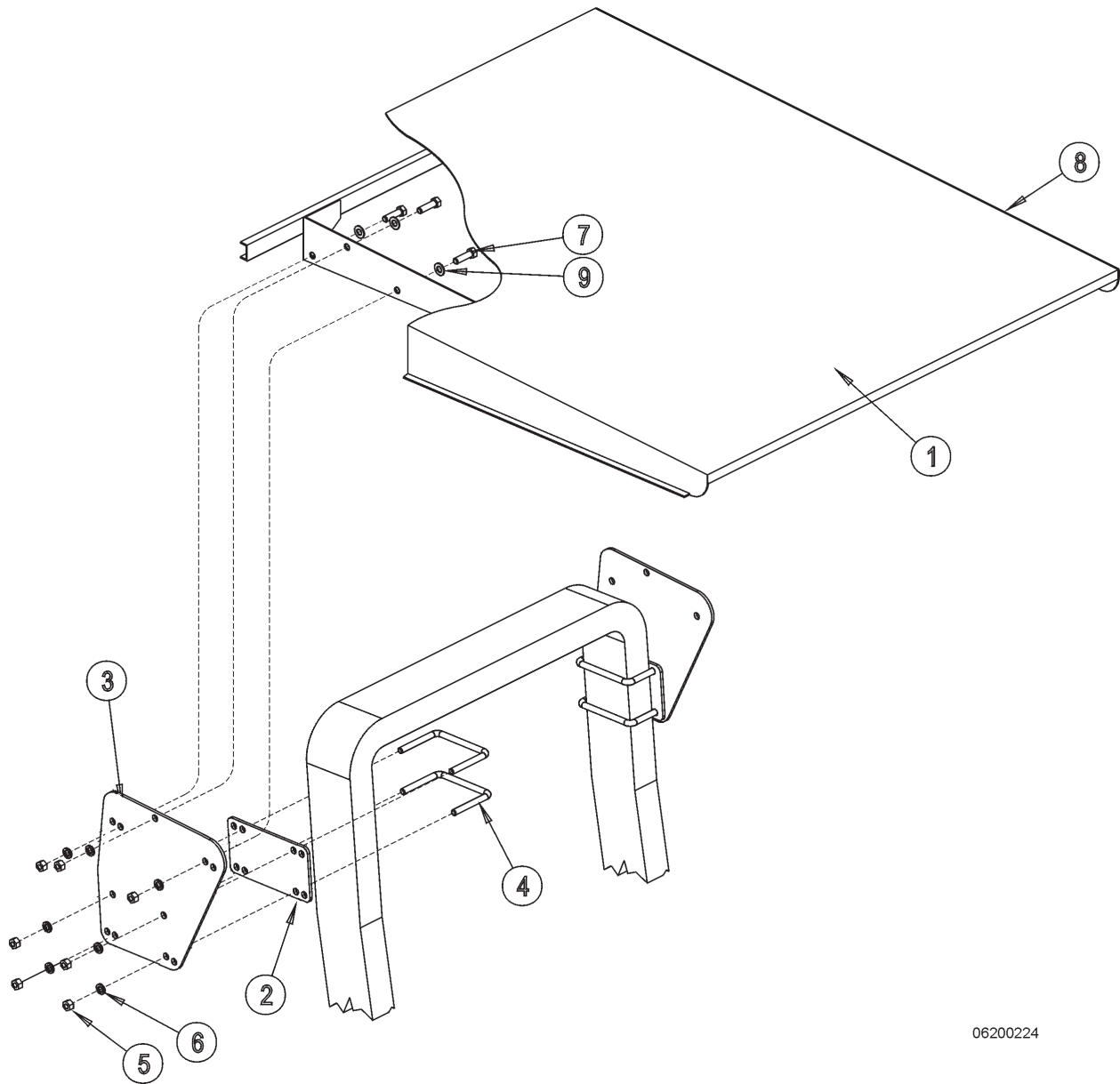

06200224

ITEM	PART NO.	QTY.	DESCRIPTION
1	6T6902	1	CANOPY
2	32730	2	SPACER CANOPY BRACKET
3	32727	2	CANOPY BRACKET
4	0642003	4	U-BOLT,3.25x5.00x.50,20NF,GR8
5	21700	14	HEX NUT - 1/2" NF
6	21990	14	LOCKWASHER - 1/2"
7	21730	6	CAPSCREW - 1/2" X 1 1/4"
8	28053	4.8'	TRIM-LOCK
9	22018	6	FLATWASHER - 1/2" WIDE

BOOM SAFETY SCREEN ASSY - WOC

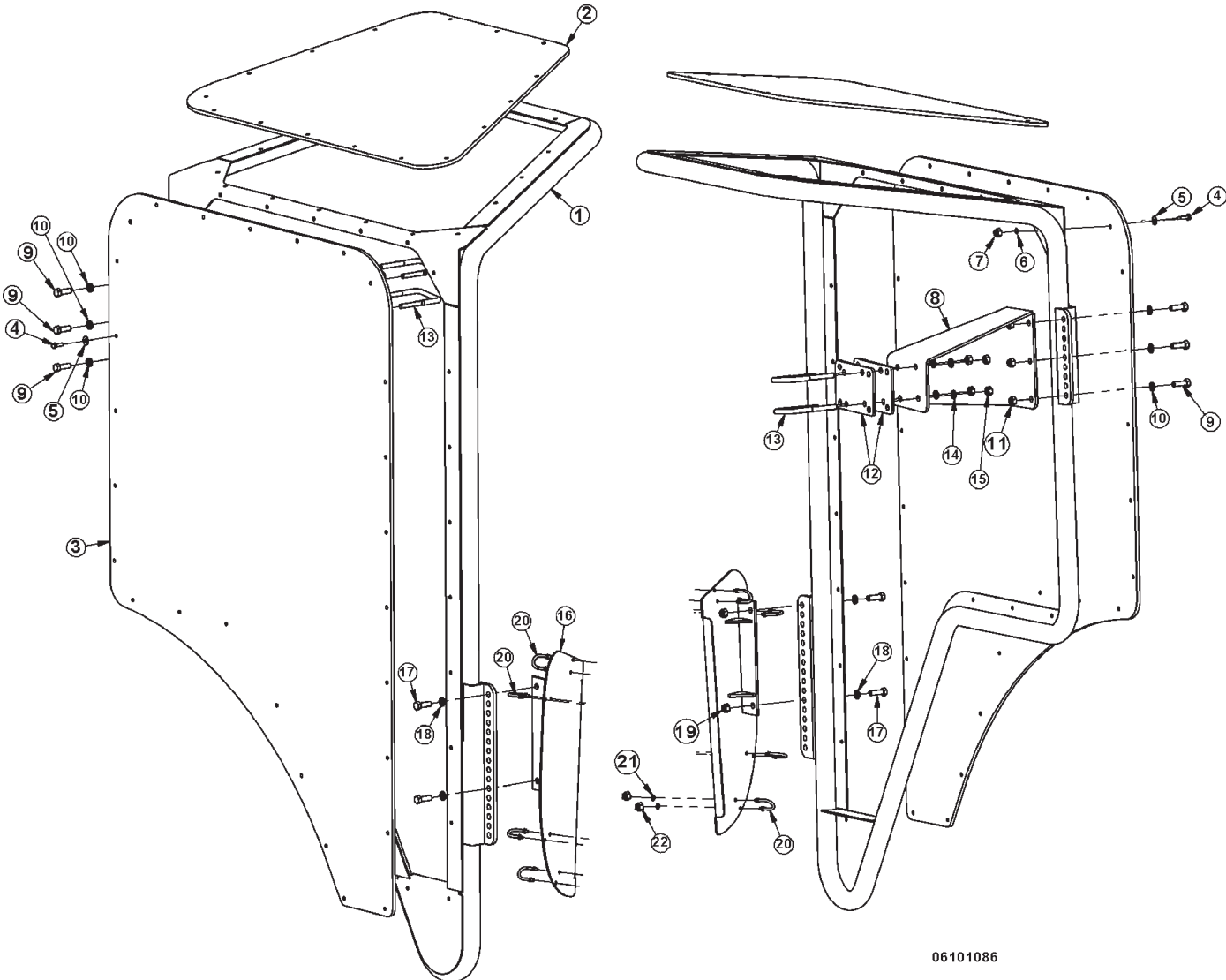

06101086

BOOM SAFETY SCREEN ASSY - WOC

ITEM	PART NO.	QTY.	DESCRIPTION
	06700008	AVAL	SAFETY,SCREEN,ASSY,TSA
1	06330010	1	SFTY SCRN,TSA,WOC
2	06490009	1	POLYCARBONATE,WINDOW,TOP,TSA
3	06490008	1	POLYCARBONATE,WINDOW,SIDE,TSA
4	21580	43	CAPSCREW,5/16 x 1 NC
5	22015	43	FLATWASHER,5/16
6	21987	43	LOCKWASHER,5/16
7	21575	43	HEX NUT,5/16 NC
8	06410117	1	MNT,TOP,SFTY SCRN,TSA115
9	21731	3	CAPSCREW,1/2x1-1/2 NC
10	21990	3	LOCKWASHER,1/2
11	21775	3	HEX NUT,1/2,NC
12	32730	2	SPACER,CANOPY BRKT,FDTS90-110
13	06420003	2	U-BOLT,3.25x5.00x.50,20NF,GR8
14	21990	4	LOCKWASHER,1/2
15	21700	4	HEX NUT,1/2 NF
16	06330009	1	FRONT MOUNT,SFTY SCREEN,TSA
17	21731	2	CAPSCREW,1/2x1-1/2 NC
18	21990	2	LOCKWASHER,1/2
19	21775	2	HEX NUT,1/2,NC
20	32550	4	U-BOLT,1/4x1x1 3/4
21	21986	8	LOCKWASHER,1/4
22	21525	8	HEX NUT ,1/4 NC

EXHAUST MOUNT

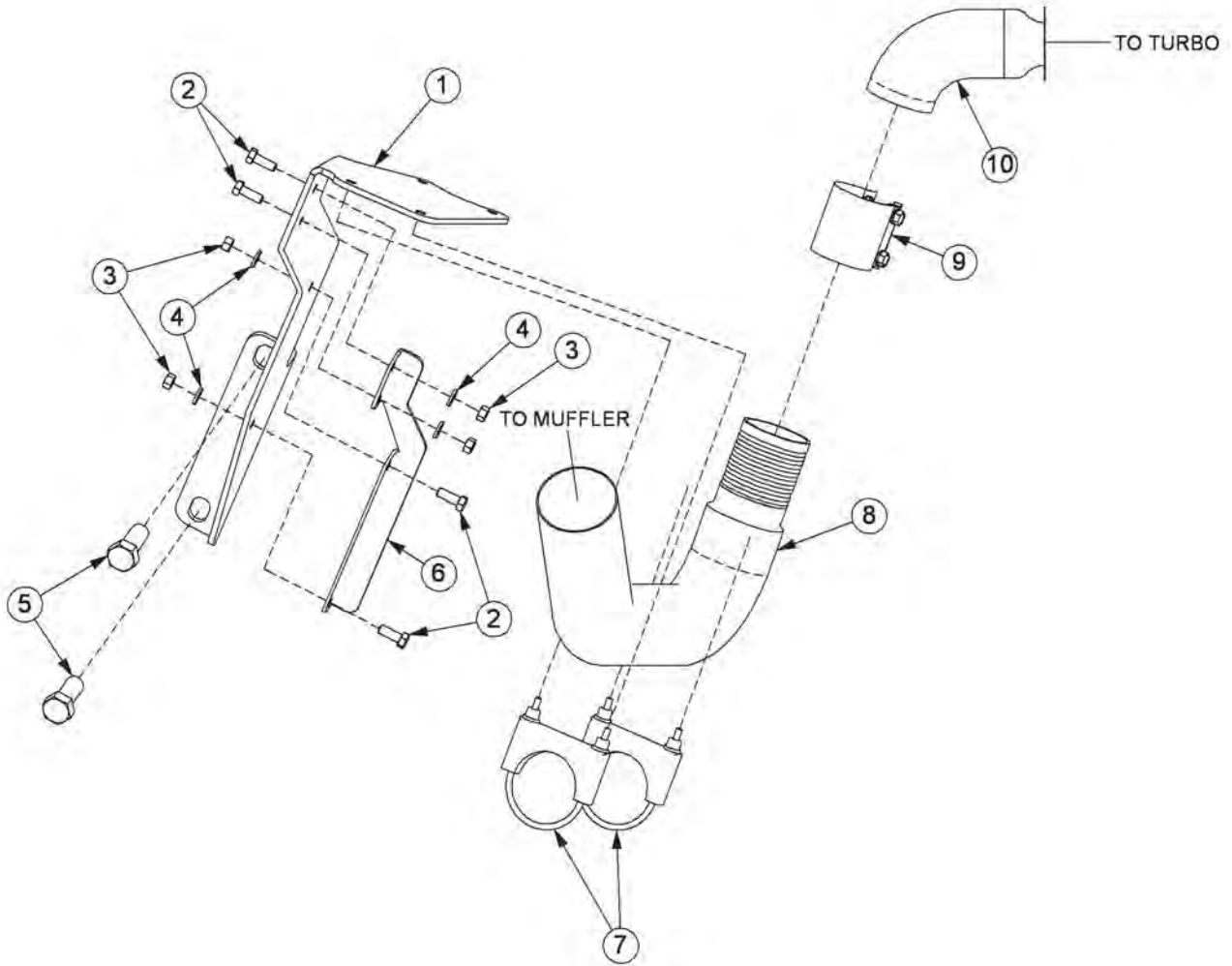

ITEM	PART NO.	QTY.	DESCRIPTION
1	06410127	1	MNT,EXHAUST,TSA100-110
2	21630	4	CAPSCREW,3/8 x 1,NC
3	21625	4	HEX NUT,3/8,NC
4	21988	4	LOCKWASHER,3/8
5	*	2	EXISTING MAINFRAME HARDWARE
6	06410128	1	MNT,EXHAUST,SUPPORT
7	35188	2	CLAMP,EXHAUST,3"
8	06520024	1	TUBE,EXHAUST,SUPPORT,4CYL
9	06520035	1	CLAMP,EXHAUST,2.75,SS,WRAP
10	*	REF	EXHAUST TUBE (CUT)

BOOM MOWER WHEEL WEIGHT KIT

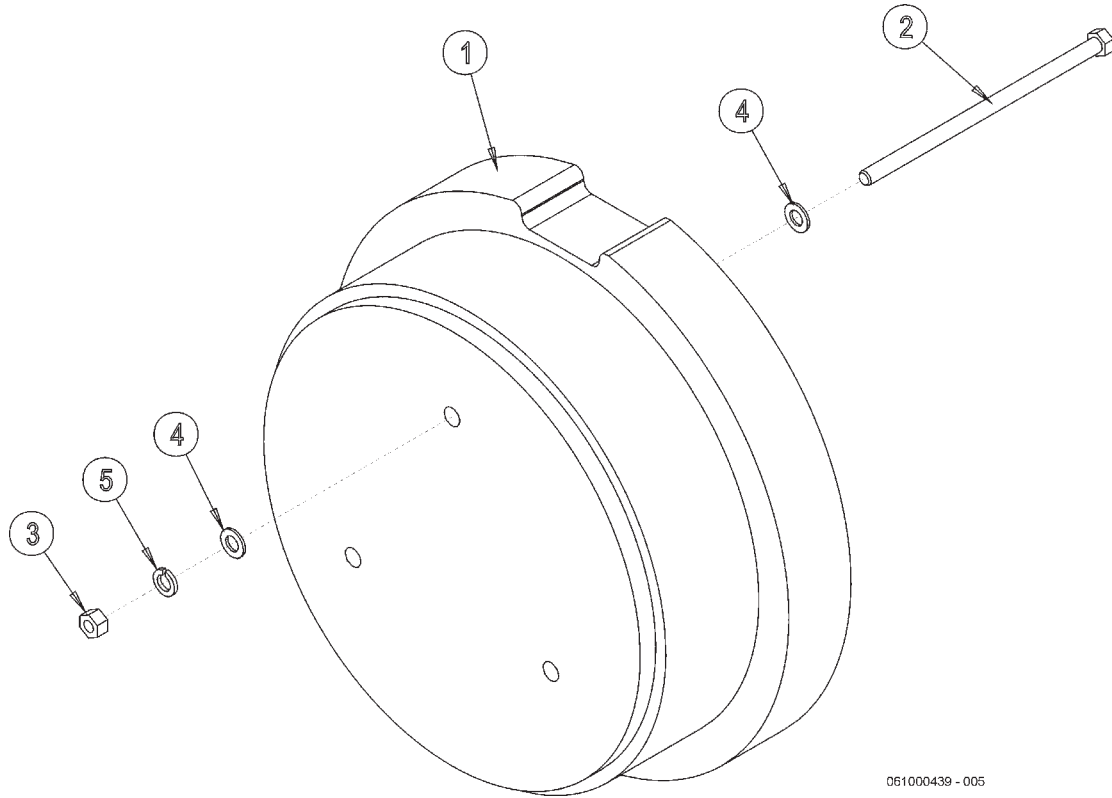

061000439 - 005

PB06100439

ITEM	PART NO.	QTY.	DESCRIPTION
1	31819	1	WHEEL WEIGHT - DRILL FOR EXTRA 500#
2	31455	3	CAPSCREW - 3/4" X 17"
3	21825	3	HEX NUT - 3/4"
4	22021	6	FLAT WASHER - 3/4"
5	21993	3	LOCKWASHER - 3/4"

PB06100005

ITEM	PART NO.	QTY.	DESCRIPTION
1	TB3226	1	WHEEL WEIGHT 1300#
2	31455	3	CAPSCREW - 3/4" X 17"
3	21825	3	HEX NUT - 3/4"
4	22021	6	FLAT WASHER - 3/4"
5	21993	3	LOCKWASHER - 3/4"

OPTIONAL PUMP AND GRILL GUARD KIT

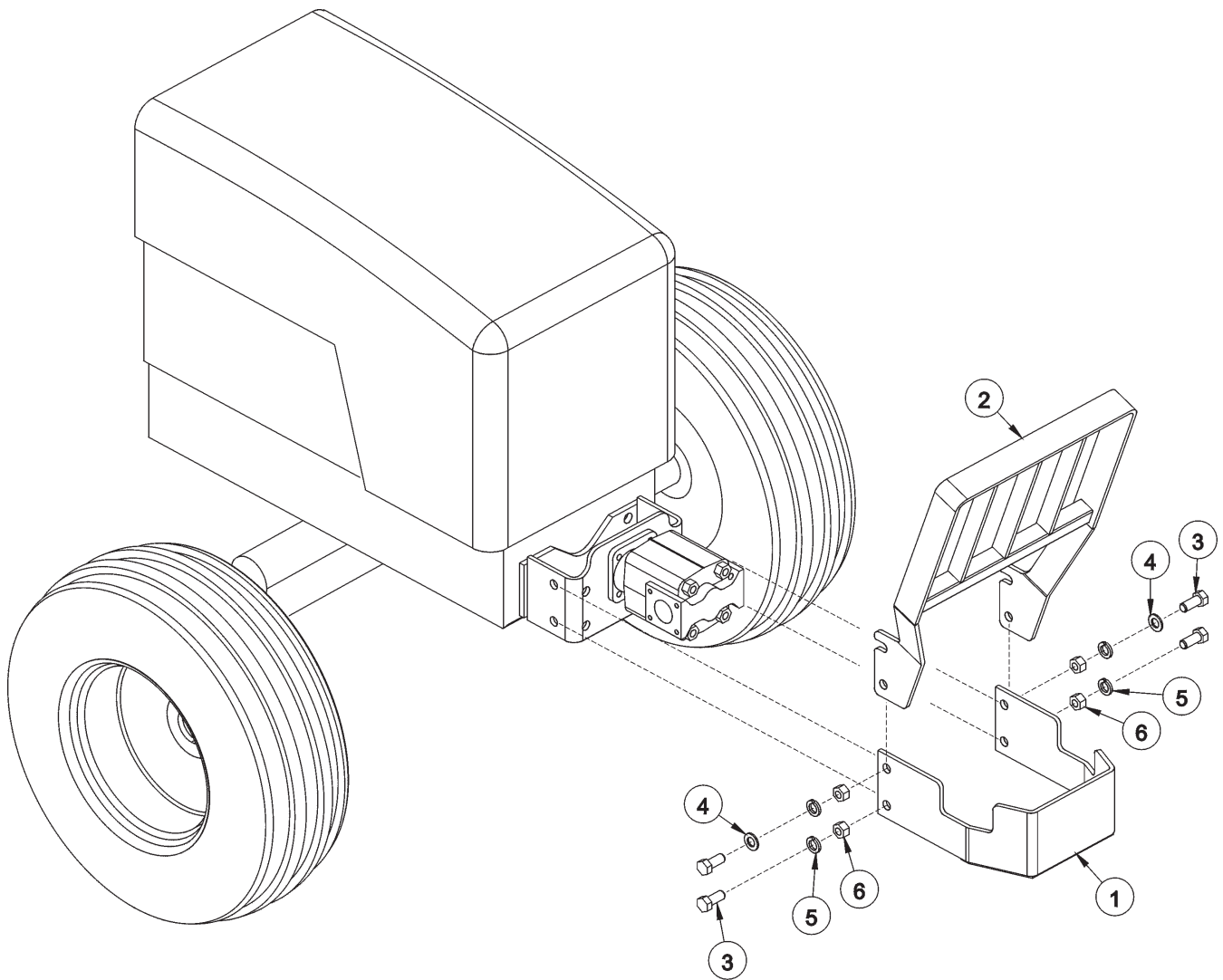

06200349

ITEM	PART NO.	QTY.	DESCRIPTION
1	32430	1	UNIVERSAL PUMP GUARD
2	32737	1	UNIVERSAL GRILL GUARD
3	21833	4	CAPSCREW - 3/4 X 2 1/4
4	22021	2	FLATWASHER - 3/4
5	21993	4	LOCKWASHER - 3/4
6	21825	4	HEX NUT - 3/4

SOLENOID BRAKE VALVE ASSEMBLY

NOTE:

CAUTION - TORQUE COIL NUT TO 5 Ft. Lbs. MAXIMUM. DO NOT OVER TORQUE NUT, DAMAGE TO CARTRIDGE OR COIL WILL OCCUR.

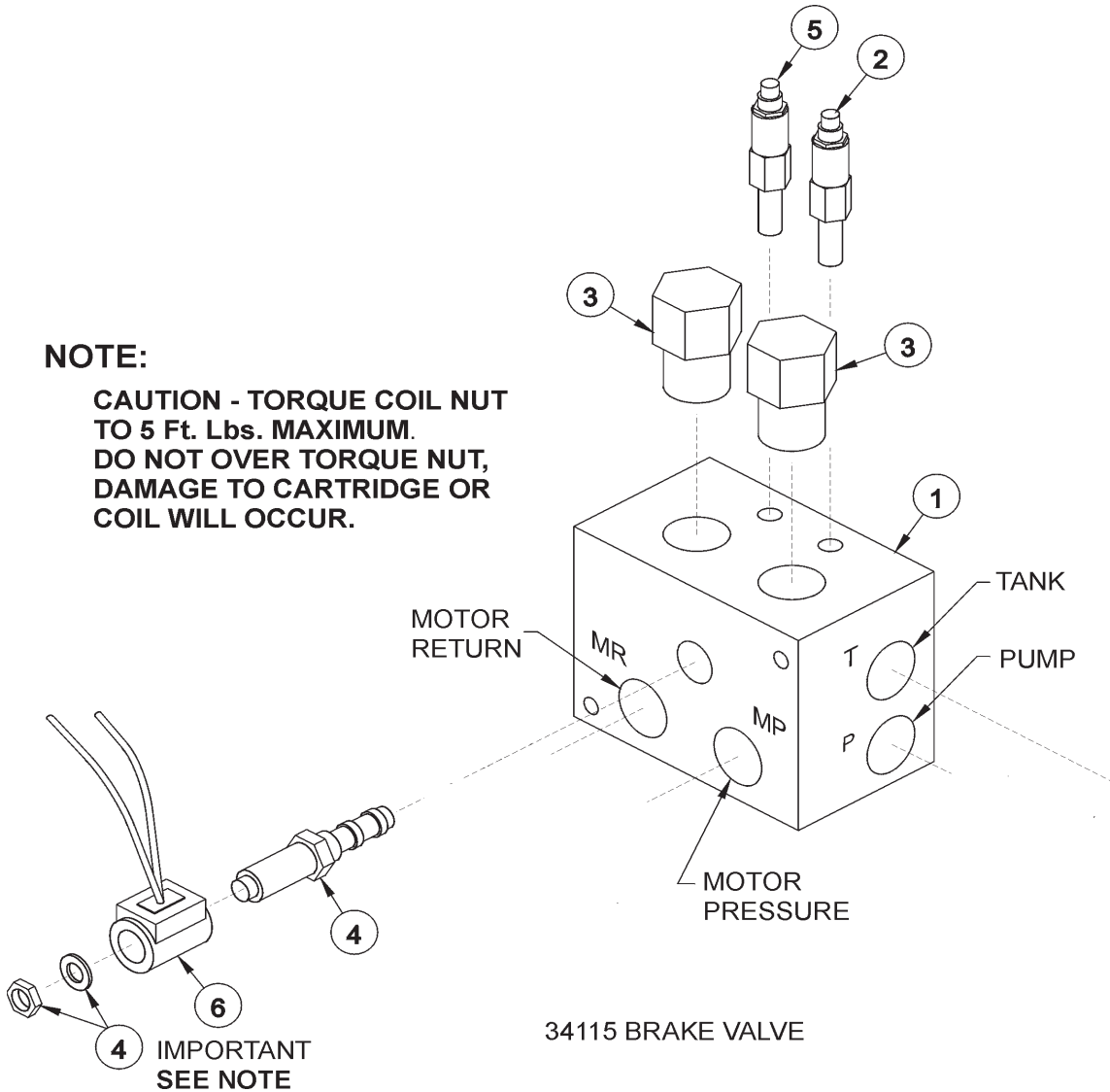

ITEM	PART NO.	QTY.	DESCRIPTION
*	34115	AVAIL	SOLENOID BRAKE VALVE ASSEMBLY - HIGH PRESSURE
1	34092	1	BRAKE VALVE, BLANK
2	34095	1	RELIEF VALVE, 3000 PSI
3	34094	2	LOGIC ELEMENT
4	34093	1	CARTRIDGE, 2 POSITION, 3 WAY (WITH NUT & WASHER)
5	34091	1	RELIEF VALVE, 2600 PSI
6	34689	1	COIL, 12 VDC, BRAKE VALVE
**	34096	2	RELIEF SEAL KIT
**	34097	1	SOLENOID SEAL KIT
**	34098	2	ELEMENT SEAL KIT
7	33555	2	ADAPTER 1" MORB x 1" MJIC
8	33554	1	ELBOW 1" MORB x 1" MJIC 45°
9	34117	1	ELBOW 1" MORB x 1" MJIC 90°

SOLENOID VALVE SWITCH AND WIRING

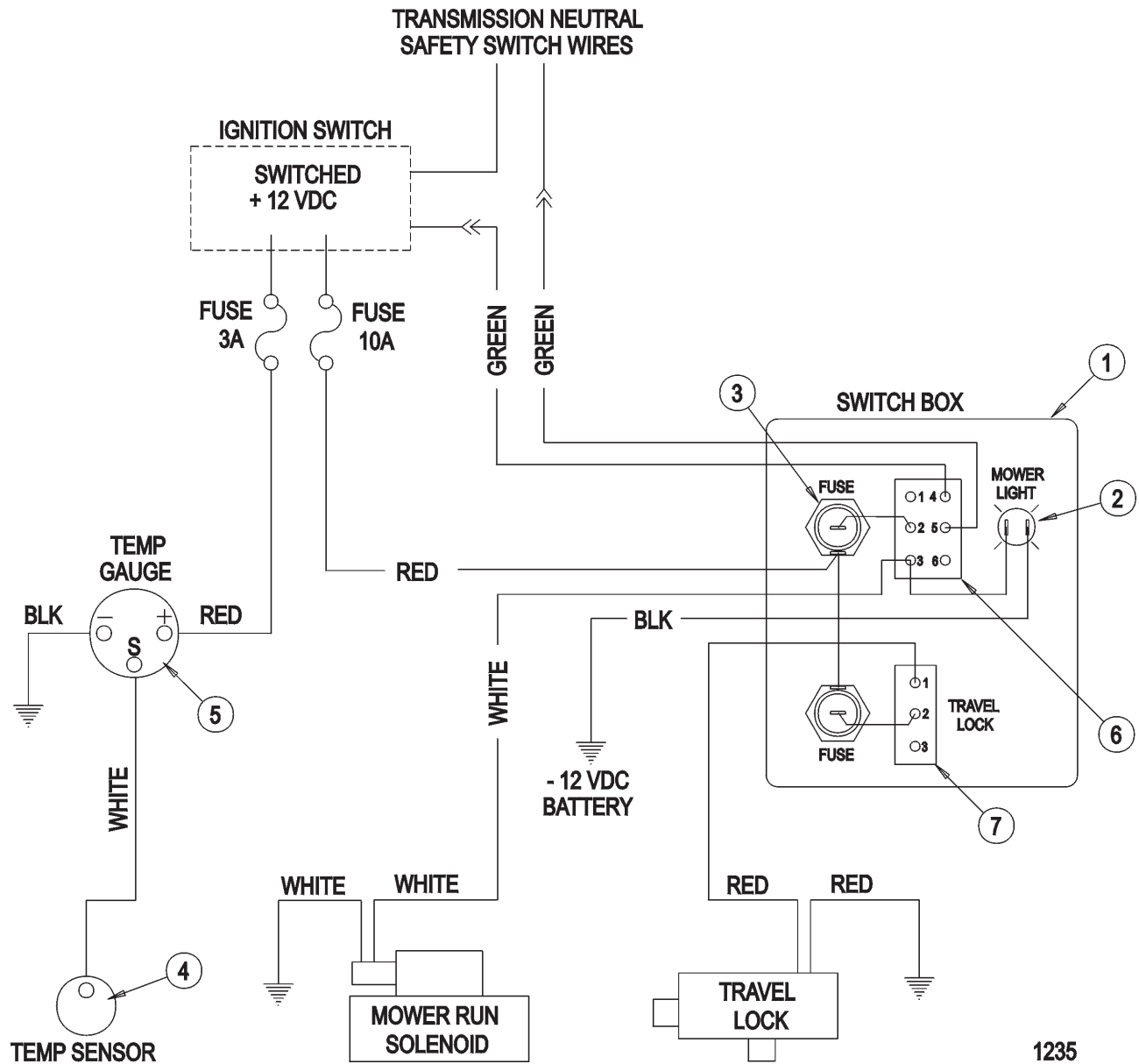

1235

ITEM	PART NO.	QTY.	DESCRIPTION
	34523	AVAIL	SWITCH BOX ASY (COMPLETE)
1	34325	1	SWITCH BOX
2	6T3923	1	INDICATOR LIGHT
3	6T3924	1	FUSE HOLDER
4	6T3931	OPT.	TEMPERATURE SENSOR
5	6T3934	OPT.	TEMPERATURE GAUGE
6	PT3905A	1	TOGGLE SWITCH, MOWER RUN
7	34532	1	TOGGLE SWITCH, TRAVEL LOCK

JOYSTICK SWITCH BOX AND WIRING

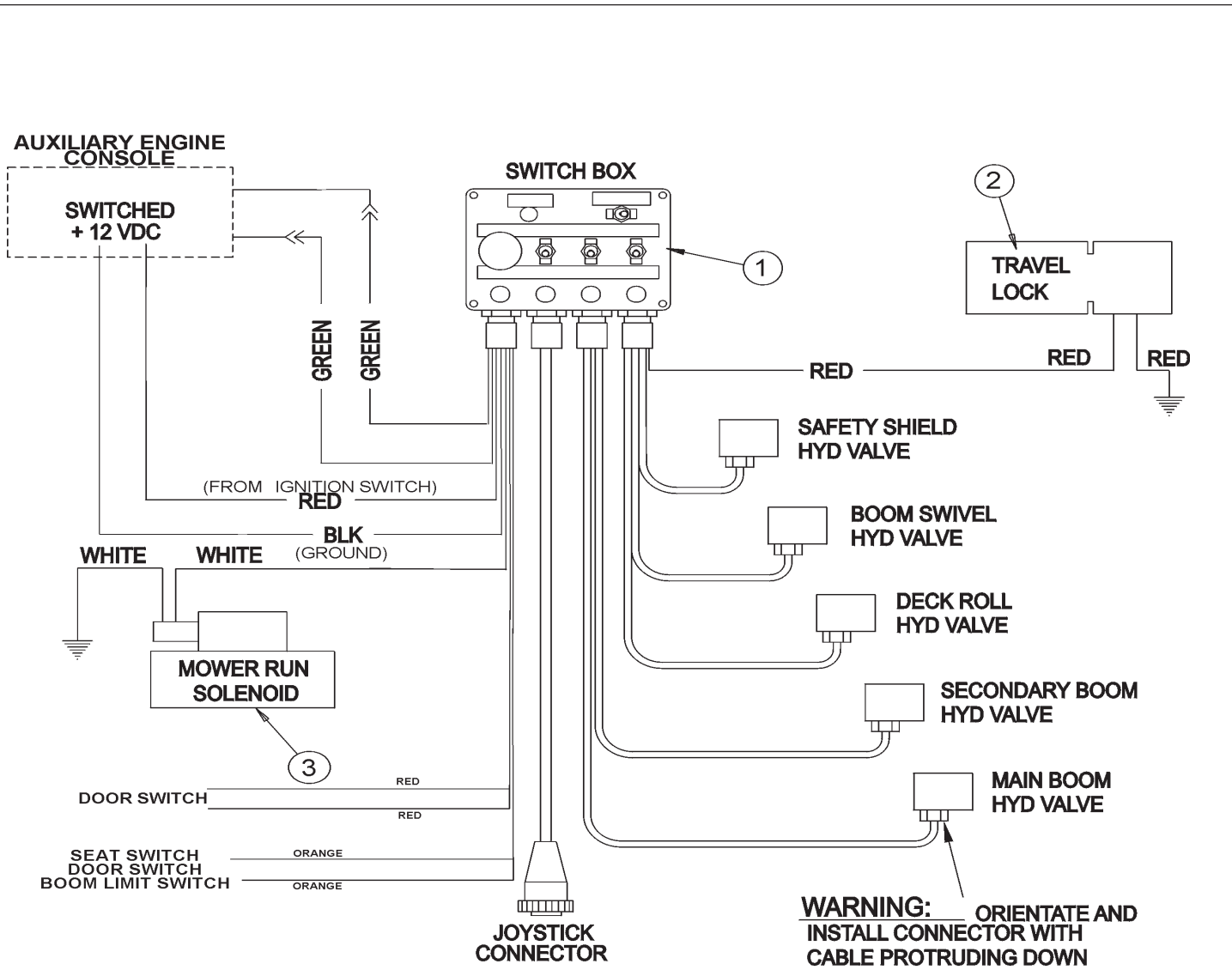

32731

ITEM	PART NO.	QTY.	DESCRIPTION
1	6T3934	OPT.	OIL TEMPERATURE GUAGE
2	6T3931	OPT.	TEMPERATURE SENSOR
3	REF.	*	SWITCH BOX - REFERTO LIFT VALVE
4	REF.	*	TRAVEL LOCK - REFERTO HYDRAULICS
5	REF.	*	SOLENOID - REFER TO MAIN FRAME

SWITCH BOX SCHEMATIC

RIGHT HAND JOYSTICK SCHEMATIC

RIGHT HAND JOYSTICK # 33691

SUB-D 25 PIN MALE PLUG FEMALE SOCKETS

1	1
2	2
3	3
4	4
6	6
9	9
22	22

JS #U -

CABLE 33693

AMP 9 PIN MALE PLUG FEMALE SOCKETS

1	1
2	2
5	5
4	4
6	6
3	3
7	7
8	8
9	9

JS #U +

DECK ROLL PROPORTIONAL #3

SEC. BOOM PROPORTIONAL #2

SWIVEL PROPORTIONAL #4

MAIN BOOM PROPORTIONAL #1

SWITCH BOX #32498 REV.A

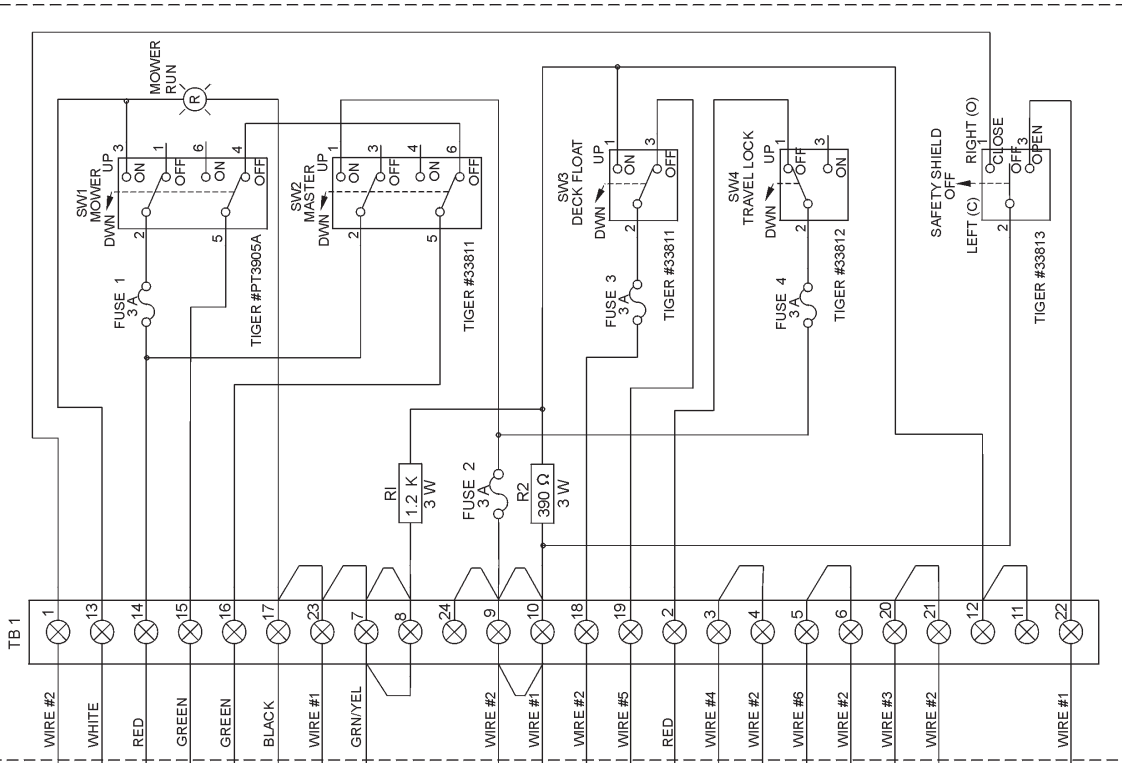

1325 AS DF SW BOX SCHEMATIC

SWITCH BOX SCHEMATIC

SWITCH BOX #32498 REV. B
(ALUMINUM, BLACK)

RIGHT HAND JOYSTICK SCHEMATIC

RIGHT HAND JOYSTICK # 33691

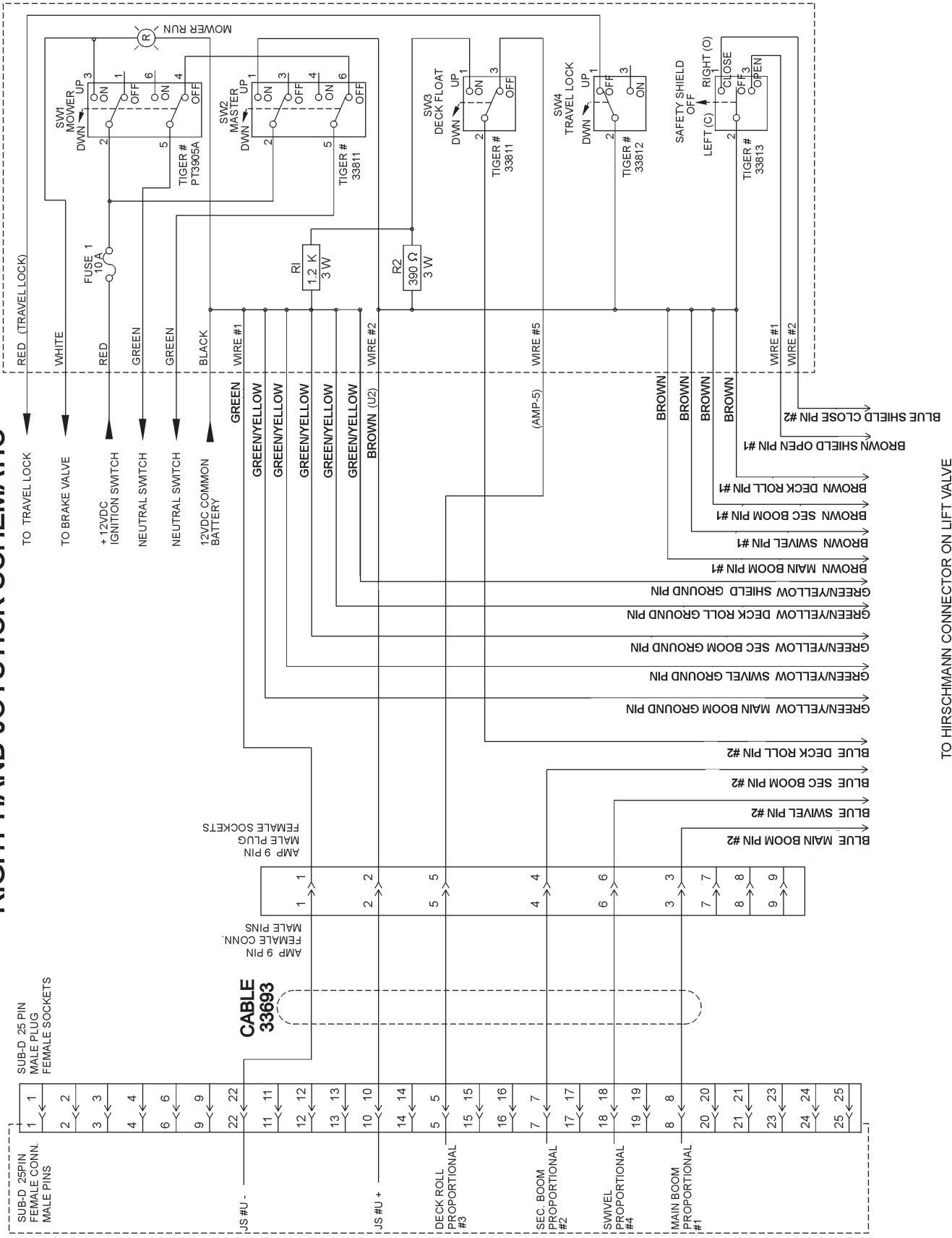

TROUBLESHOOTING

JOYSTICK TROUBLESHOOTING

Boom operation not responding to joystick movement.

Isolate hydraulic vs. electronic symptom.

Turn off electronic master switch (preventing electronic actuator on valve from attempting to hold spool in neutral position). With tractor engine running, operate the valve section with the manual handle. If function operates normally, continue with electronic inspection. If function does not operate normally, continue with hydraulic inspection.

Electronic inspection.

Connect a voltmeter to the cable connector of the valve section that is not operating. This will allow you to measure supply and signal voltage when the joystick is operated.

Main, Secondary, and Swivel Valves – signal voltage should be 50% of supply voltage with joystick in Neutral position, up to 75% of supply voltage in B direction, down to 25% of supply voltage in A direction. Signal voltage should change smoothly with lever movement.

Pin #1 – Supply Voltage Pin #2 – Signal Voltage Pin #gnd – ground

Deck Roll Valve or Float Valve – signal voltage should be 50% of supply voltage with joystick in Neutral position, up to 65% of supply voltage in B direction, down to 35% of supply voltage in A direction. Signal voltage should change smoothly with lever movement. Signal voltage should be approximately 75% of supply voltage when float switch is operated.

Pin #1 – Supply Voltage Pin #2 – Signal Voltage Pin #gnd – ground

Shield Valve or On/Off Valve – Voltage on pin #1 should be equal to supply voltage when switch is operated in A direction. Voltage on pin #2 should be equal to supply voltage when switch is operated in B direction.

Pin #1 – Signal Voltage Pin #2 – Signal Voltage Pin #gnd – ground

If none of the valve will operate with electrical signal, verify that there is oil pressure at the valve inlet. Electrical Valves must have pilot supply oil to move the spools.

Possible electronic problems.

Open circuit (broken wire, bad connection or loose connection in switch box).

Shorted to positive, ground, or other.

Incorrect voltage signal from joystick.

Continued on next sheet

TROUBLESHOOTING

Hydraulic inspection.

Install 3 pressure gauges, on the valve inlet (use M port, or tee into hose supplying oil from the pump to the inlet), on the workport that is not operating, and on the LS port.

With the spools in Neutral

Gear pump – P should be approximately 200 psi, LS = 0, workport – pressure on cylinder or function.

LS pump – P should equal pump standby pressure, LS = 0, workport – pressure on cylinder or function.

Pressure Comp pump – P should equal pump standby pressure, LS = 0, workport – pressure on cylinder or function.

Gear pump – P should be approximately 200 psi higher than LS, LS should equal workport, workport – pressure on cylinder or function.

LS pump – P should be LS + standby, LS should equal workport, workport – pressure on cylinder or function.

Pressure Comp pump – P should equal pump standby pressure, LS should equal workport, workport – pressure on cylinder or function.

Operate one spool, measure pressures with function at end of travel or stop

Gear pump – P should equal valve relief setting or workport shock valve setting. LS should equal workport. Workport should equal relief setting or workport shock valve setting.

LS pump – P should equal valve relief setting, pump max pressure setting, or workport shock valve setting. LS should equal workport. Workport should equal relief setting, pump max pressure setting, or workport shock valve setting.

Pressure Comp pump – P should equal pump standby pressure, LS should equal workport. Workport should equal pump standby pressure or workport shock valve setting.

Operate more than one spool.

Gear pump – P should approximately 200 psi higher than LS. LS should equal highest workport pressure. Workport – pressure on cylinder or function.

LS pump – P should be LS + standby pressure. LS should equal highest workport pressure. Workport – pressure on cylinder or function.

Pressure Comp pump. P should equal pump standby pressure. LS should equal highest workport pressure. Workport – pressure on cylinder or function.

Possible hydraulic problems.

Cylinder leak.

LS signal leaking to tank before reaching pump LS port.

Hydraulic system or pump not supplying flow to valve.

HYDRAULIC - TROUBLESHOOTING GUIDE

Hydraulic Troubleshooting guide

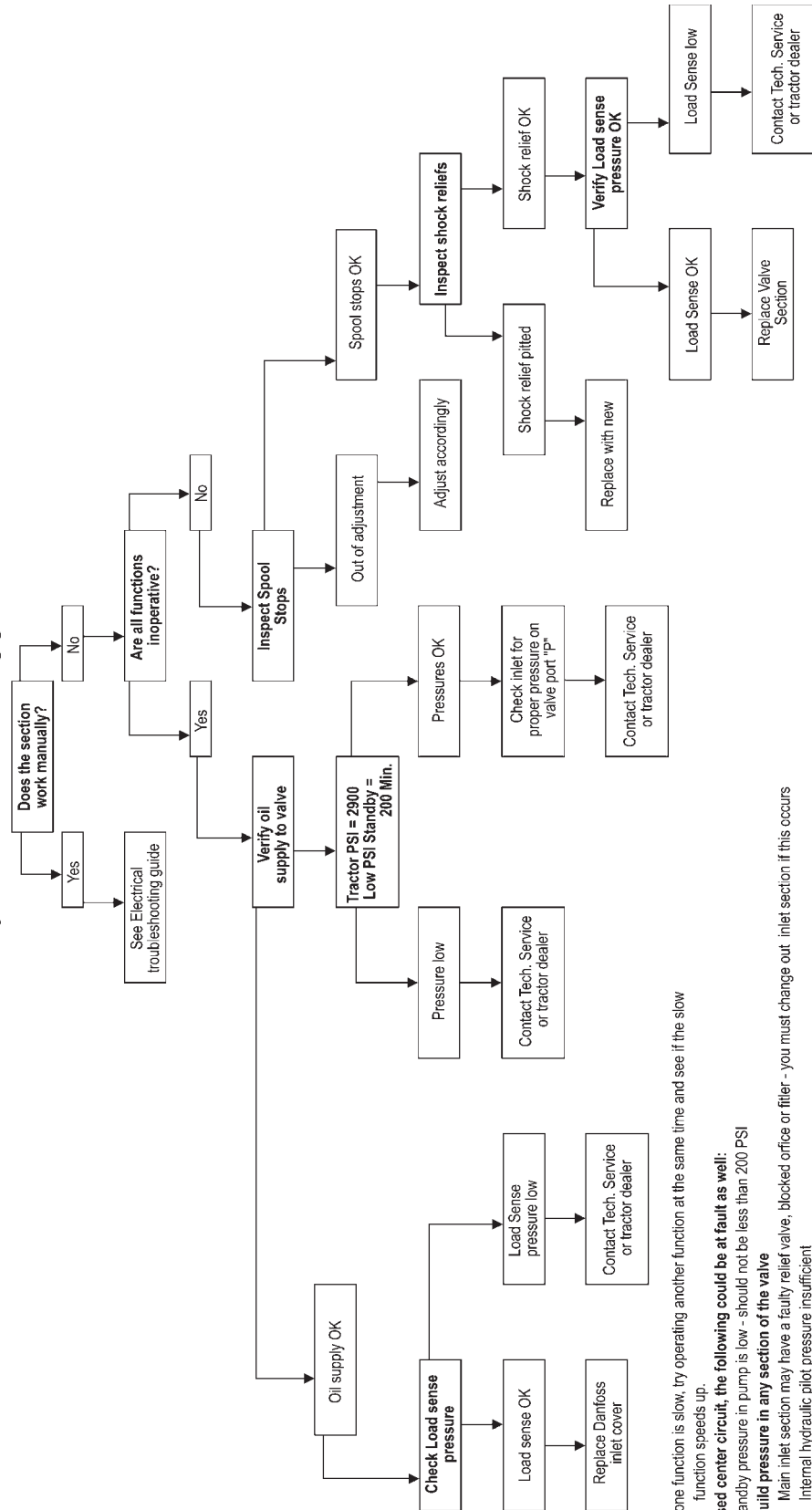

Notes: If one function is slow, try operating another function at the same time and see if the slow function speeds up.

On a closed center circuit, the following could be at fault as well:

Tractor standby pressure in pump is low - should not be less than 200 PSI

Cannot build pressure in any section of the valve

Main inlet section may have a faulty relief valve, blocked orifice or filter - you must change out inlet section if this occurs

Internal hydraulic pilot pressure insufficient

ELECTRICAL - TROUBLESHOOTING GUIDE

Danfoss Electrical Troubleshooting guide

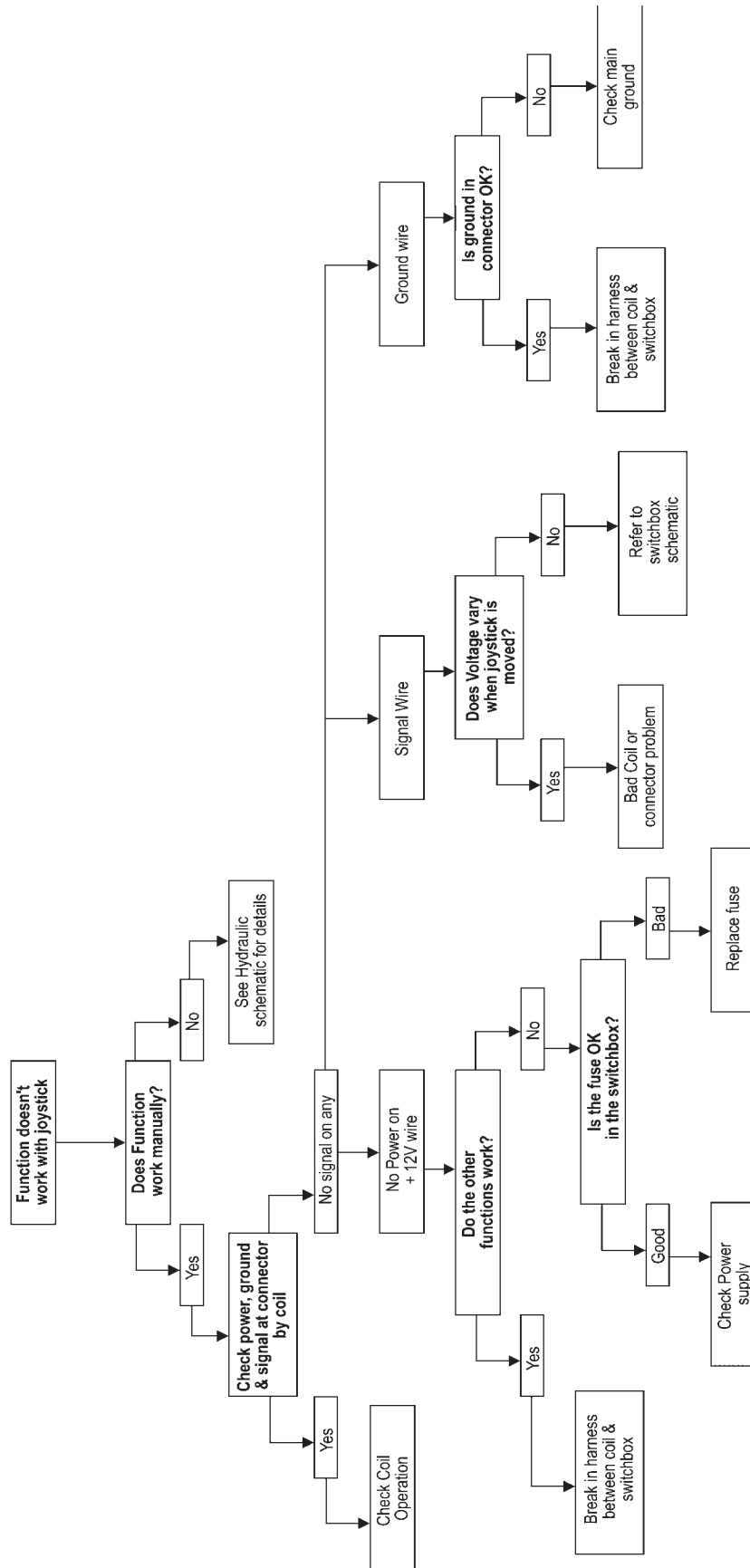

Empty rectangular box at the top of the page.

Large empty rectangular box occupying the main body of the page.

BENGAL BOOM COMMON

PARTS SECTION

TABLE OF CONTENTS

BOOM PARTS	PAGE
BOOM ARM ASSEMBLY - ATTENTION!	6-4
BOOM SWIVEL HOSE ROUTING	6-5
STANDARD BOOM ARM ASSY - SIDE STOW	6-6
STANDARD BOOM SIDE STOW HOSES	6-8
STANDARD BOOM ARM ASSY - OPEN STOW, 3PS	6-10
STANDARD BOOM - OPEN STOW, 3PS HOSES	6-12
EXTENDED BOOM ARM	6-14
BOOMREST - 3 POINT STOW	6-16
HOSE SUPPORT - EXTENDED BOOM	6-17
BOOMREST - OPEN STOW	6-18
BOOM ROTARY PIVOT	6-20
BOOM FLAIL PIVOT	6-22
50" BOOM ROTARY MOWER	6-24
60" BOOM ROTARY MOWER	6-26
50" ROTARY KNIVES AND DISK	6-30
50" BLADE BAR AND KNIVES	6-31
60" ROTARY KNIVES AND DISK	6-32
60" BLADE BAR AND KNIVES	6-33
50" BOOM FLAIL DRIVE	6-34
50" BOOM FLAIL CUTTER SHAFT	6-36
63" BOOM FLAIL DRIVE	6-38
63" BOOM FLAIL CUTTER SHAFT	6-40
HYDRAULIC CYLINDERS	6-42
ROTARY MOWER SPINDLE	6-48
RESERVOIR TANK FILTER ASSEMBLY	6-50
ELECTRONIC VALVE BREAKDOWNS	6-52
FRONT HYDRAULIC PUMP	6-56
TSR MOTOR	6-56
ROTARY MOWER MOTOR	6-58
FLAIL MOTOR	6-60
BOOM TRAVEL LOCK	6-62
SWITCHBOX	6-63
BRAKE VALVE	6-67
TROUBLESHOOTING	6-69
CLEAN CUTTER BOOM	6-73
FIRE SUPPRESSION SYSTEM	6-81

PARTS ORDERING GUIDE

The following instructions are offered to help eliminate needless delay and error in processing purchase orders for the equipment in this manual.

1. The Parts Section is prepared in logical sequence and grouping of parts that belong to the basic machine featured in this manual. Part Numbers and Descriptions are given to help locate the parts and quantities required.

2. The Purchase Order must indicate the **Name and Address** of the person or organization ordering the parts, **who should be charged**, and if possible, the **serial number of the machine** for which the parts are being ordered.

3. The purchase order must clearly list the **quantity of each part**, the complete and correct **part number**, and the basic **name of the part**.

4. The manufacturer reserves the right to substitute parts where applicable.

5. Some parts may be unlisted items which are special production items not normally stocked and are subject to special handling. Request a quotation for such parts before sending a purchase order.

6. The manufacturer reserves the right to change prices without prior notice.

NOTE: When ordering replacement decals, refer to the part numbers and descriptions listed in the safety section in the front of this manual.



1000

For maximum safety and to guarantee optimum product reliability, always use genuine **Tiger** replacement parts. The use of inferior replacement parts may cause premature or catastrophic failure which could result in serious injury or death.

Direct any questions regarding parts to:

Tiger Corporation
3301 N. Louise Ave.
Sioux Falls, SD 57107
1-800-843-6849
1-605-336-7900

BOOM ARM ASSEMBLY - ATTENTION!

This pertains to Husco controlled boom units that do not use 06502036 check valve adapter . Please note the adapter and restrictor which are added to the main and secondary boom cylinder for proper boom operation.



ASSEMBLY OF RESTRICTORS INTO THE MAIN BOOM & SECONDARY BOOM CYLINDER:

1. ON THE MAIN BOOM CYLINDER, ASSEMBLE ADAPTER 34073 INTO THE TRAVEL LOCK. ASSEMBLE RESTRICTOR 34072 INTO 34073 AS SHOWN ABOVE IN THE ILLUSTRATION, THEN ASSEMBLE ADAPTER 33271 INTO 34073 AND FINALLY ASSEMBLE THE HOSE ON TO 33271.
2. ON THE SECONDARY BOOM CYLINDER, ASSEMBLE 34073 INTO THE GLAND END PORT, THEN ASSEMBLE RESTRICTOR 34072 INTO 34073 AS SHOWN ABOVE IN THE ILLUSTRATION. FINALLY, ASSEMBLE THE HOSE INTO 34073.

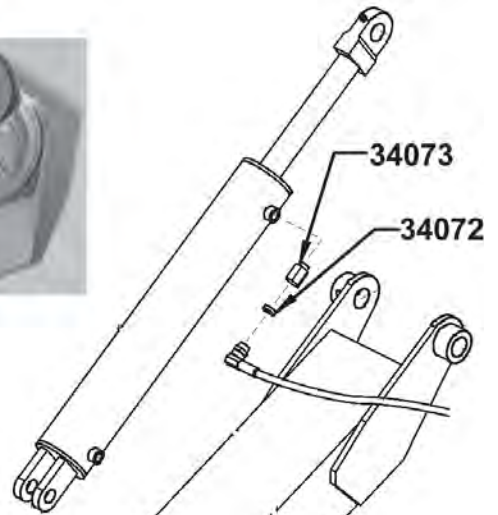
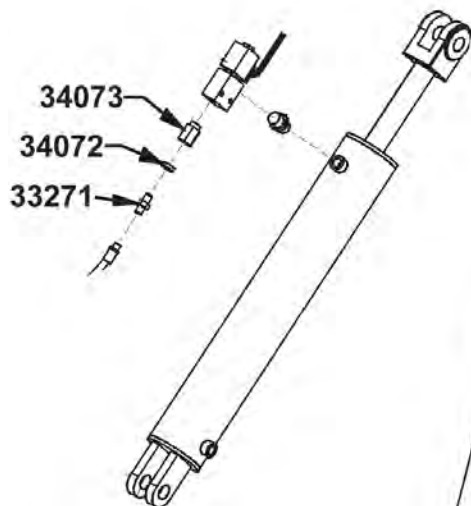

BOOM HOSES ROUTING - OPEN & 3 POINT STOW BOOMS

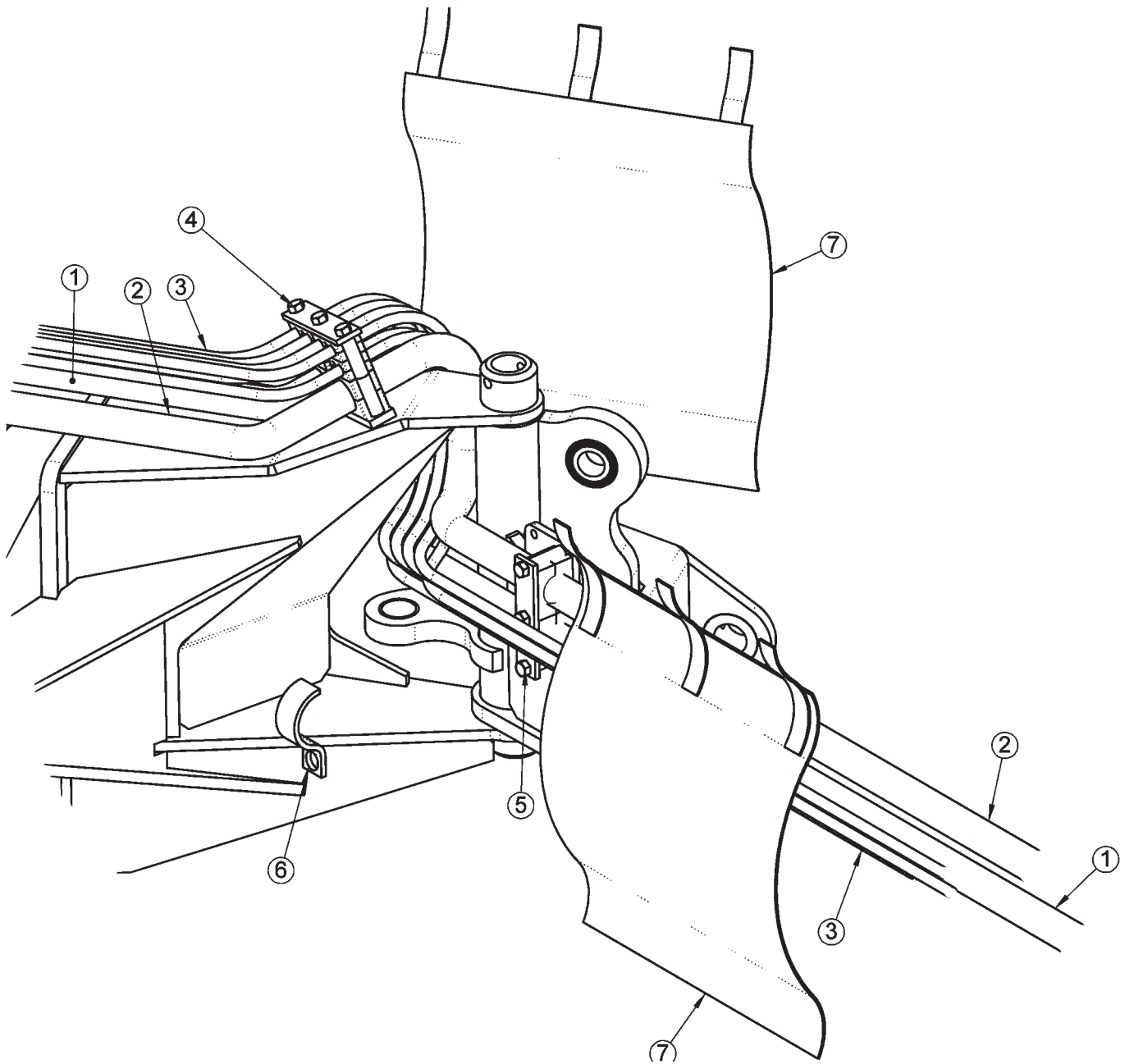

ITEM	PART NO.	QTY.	DESCRIPTION
1	-	1	1" HOSE TO MAIN BOOM LOWER TUBE
2	-	1	1" HOSE TO MAIN BOOM UPPER TUBE
3	-	6	1/4" HOSE TO MAIN BOOM
4	06505085	1	CLAMP KIT
5	35131	1	CLAMP KIT
6	TB3012	1	CLAMP
7	06505021	2	HOSE COVER"

STANDARD BOOM ASSEMBLY - SIDE STOW

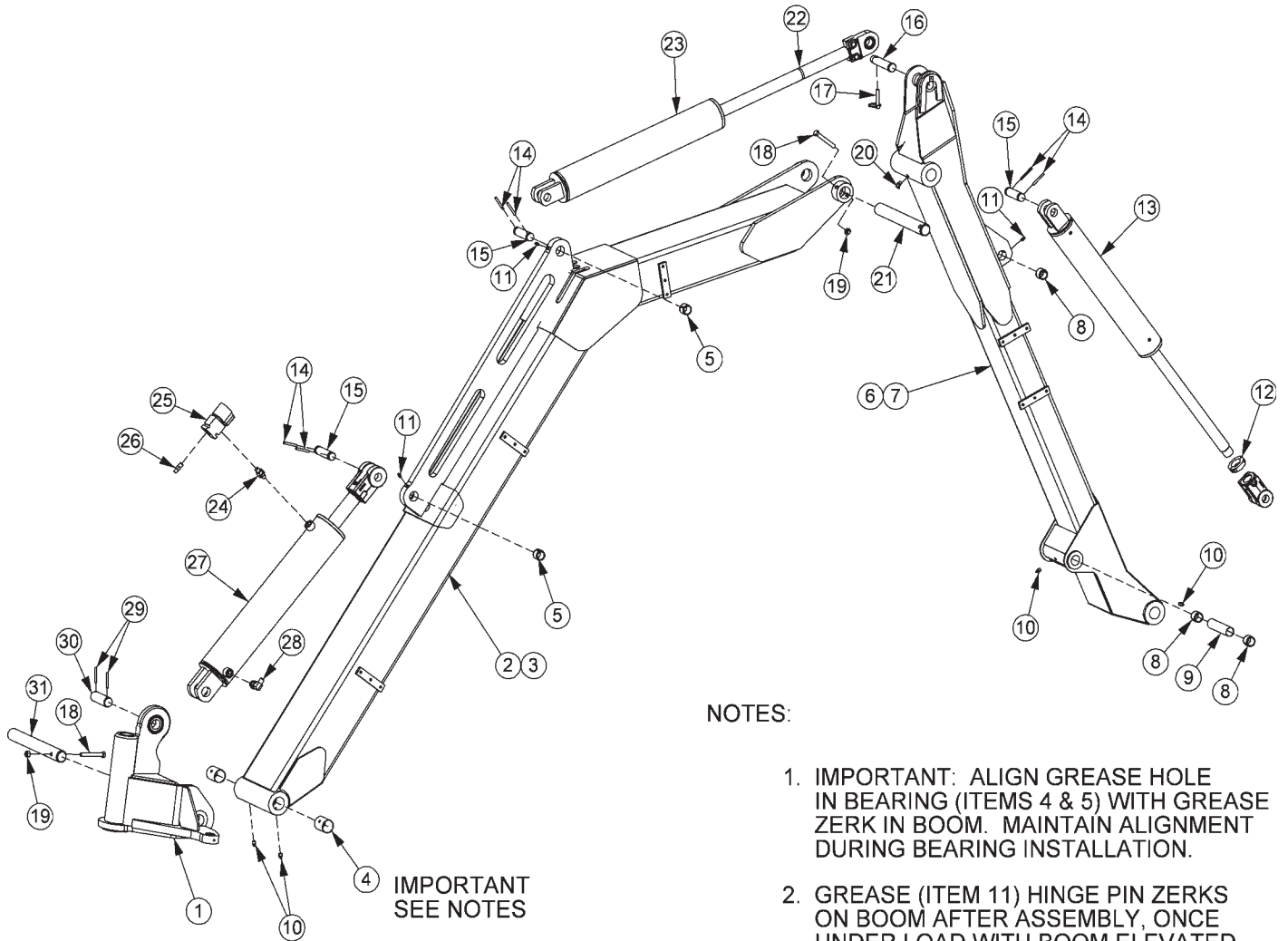

NOTES:

1. IMPORTANT: ALIGN GREASE HOLE IN BEARING (ITEMS 4 & 5) WITH GREASE ZERK IN BOOM. MAINTAIN ALIGNMENT DURING BEARING INSTALLATION.
2. GREASE (ITEM 11) HINGE PIN ZERKS ON BOOM AFTER ASSEMBLY, ONCE UNDER LOAD WITH BOOM ELEVATED AND AGAIN AT REST WITH BOOM SUPPORTED.

STANDARD BOOM ASSEMBLY - SIDE STOW

ITEM	PART NO.	QTY.	DESCRIPTION
1	*	REF	SWIVEL ASSY *REFER TO TRACTOR MOUNT KIT
2	24512	1	MAIN BOOM ARM ASSY
3	TB1002D	1	MAIN BOOM WLDMENT
4	32321	2	BUSHING, 1-1/2"ID x 2-1/2"
5	TB3010	2	BUSHING, 1"ID
6	24517	1	SECONDARY BOOM ARM ASSY
	06700098	AVAIL.	SHORT SEC BOOM ARM ASSY (FOR 60" RTRY)
7	TB1001G	1	SECONDARY BOOM WLDMENT
8	TB3010	3	BUSHING, 1"ID
9	TB1035	1	BUSHING,SPACER
10	6T3211	4	GREASE ZERK, 1/8"
11	6T3207	3	GREASE ZERK, 1/4"
12	35312	1	SET COLLAR
13	06501023	1	CYLINDER, 3" x 18"
14	06537021	6	ROLL PIN, 5mm
15	TB1033	3	PIN, 1" x 4"
16	TB1036	1	PIN, 1" x 4-11/16"
17	TF1143	1	PIN, LYNCH
18	21688	2	CAPSCREW, 7/16" x 3-1/4", NC
19	21677	2	NYLOCK NUT, 7/16", NC
20	6T3210	1	GREASE ZERK, 1/8" x 90°
21	TB1025	1	PIN, 1-1/2" x 12"
22	22076	1	SPACER, DECK LIFT CYL
23	06501024	1	CYLINDER, 3-1/2" x 20"
24	31329	1	ADAPTER, 1/2ORB x 1/2ORB ADJ
25	06510050	1	TRAVEL LOCK, METRIPACK COIL
26	33271	1	ADAPTER, 1/2ORB x 1/2ORB ADJ
27	06501022	1	CYLINDER, 4" x 20"
28	32810	1	ELBOW, 1/2ORB x 3/8MJ90ADJ
29	TB1023	2	ROLL PIN, 7/32"
30	06420100	1	PIN, 1-1/4" x 3-5/8"
31	TB3013C	1	PIN, 1-1/2" x 12-3/4"

STANDARD BOOM - SIDE STOW HOSES

NOTES:

1. PRESSURE AND RETURN LINES ARE OPPOSITE AS SHOWN FOR STANDARD ROTATION BOOM FLAIL MOWERS.

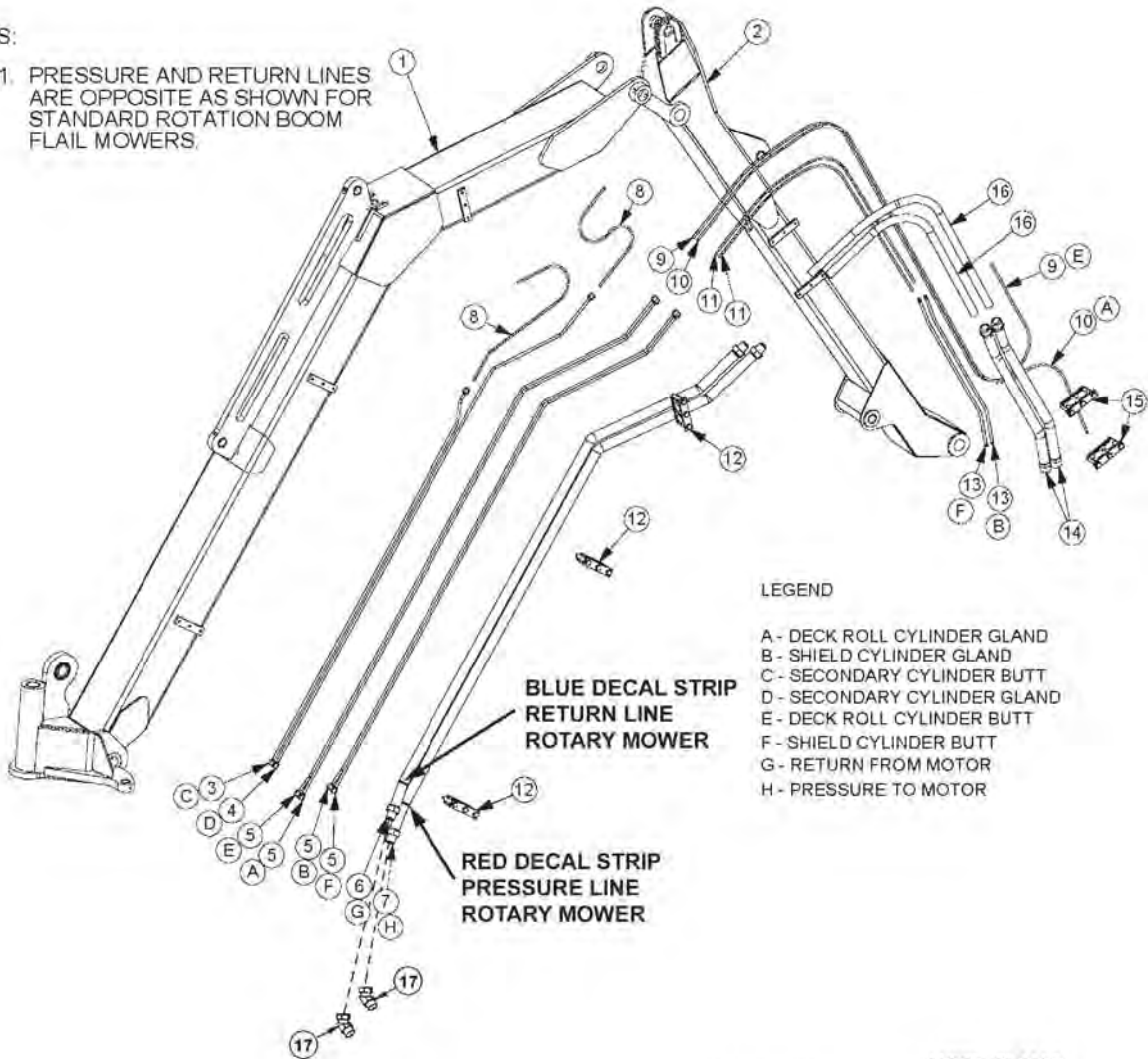

LEGEND

- A - DECK ROLL CYLINDER GLAND
- B - SHIELD CYLINDER GLAND
- C - SECONDARY CYLINDER BUTT
- D - SECONDARY CYLINDER GLAND
- E - DECK ROLL CYLINDER BUTT
- F - SHIELD CYLINDER BUTT
- G - RETURN FROM MOTOR
- H - PRESSURE TO MOTOR

HOSE CLAMP
ITEM 12

HOSE CLAMP
ITEM 15

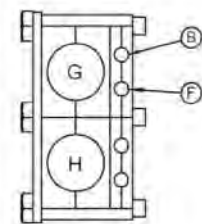
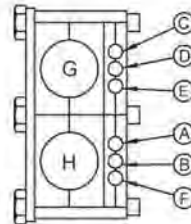

STANDARD BOOM - SIDE STOW HOSES

ITEM	PART NO.	QTY.	DESCRIPTION
1	*	REF	MAIN BOOM *REFER TO BOOM ARM ASSY
2	*	REF	SECONDARY BOOM *REFER TO BOOM ARM ASSY
3	TB2025	1	PRFRMD TUBE #304
4	TB2026	1	PRFRMD TUBE #305
5	TB2028	4	PRFRMD TUBE #307
6	24035A	1	PRFRMD TUBE, MAIN BOOM RETURN
7	24034A	1	PRFRMD TUBE, MAIN BOOM PRESSURE
8	34052	2	HOSE, 1/4" x 20"
9	34078	1	HOSE, 1/4" x 48"
10	34079	1	HOSE, 1/4" x 68"
11	34104	2	HOSE, 1/4" x 42"
12	33440	3	TUBE CLAMP, MAIN BOOM (ROTARY MOWERS)
	30111	*	TUBE CLAMP, MAIN BOOM (FLAIL MOWERS)
13	34102	2	TUBE, PRFRMD, SEC BOOM
14	2403306	2	TUBE, PRFRMD, SEC BOOM, HP
15	30111	2	TUBE CLAMP, SEC BOOM (ROTARY MOWERS)
	30112	*	TUBE CLAMP, SEC BOOM (FLAIL MOWERS)
16	24488	2	HOSE, 1" x 40"
17	24724	2	SWIVEL, 1MJ x 1FJX45

STANDARD BOOM ASSEMBLY - OPEN STOW, 3PS

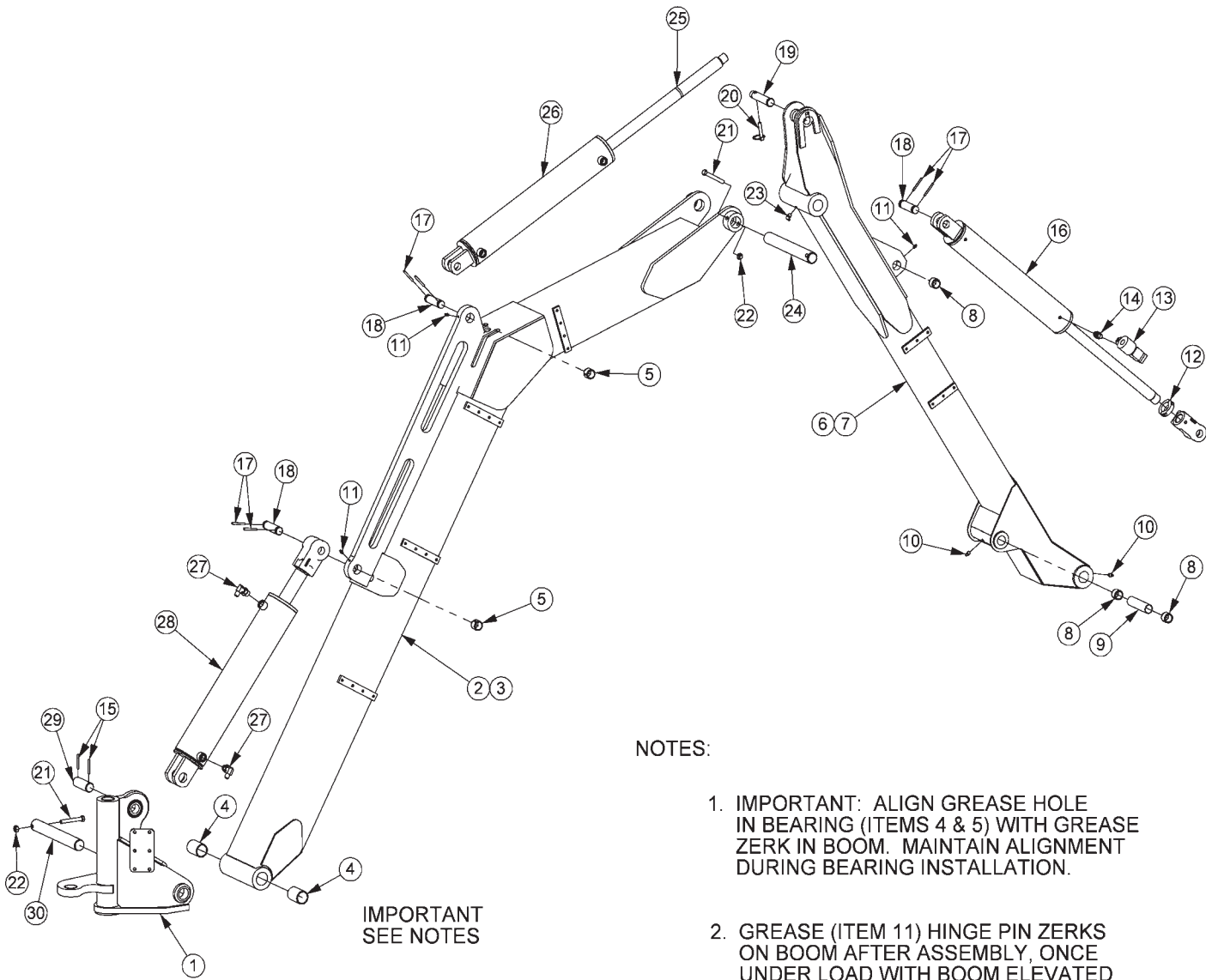

NOTES:

1. IMPORTANT: ALIGN GREASE HOLE IN BEARING (ITEMS 4 & 5) WITH GREASE ZERK IN BOOM. MAINTAIN ALIGNMENT DURING BEARING INSTALLATION.
2. GREASE (ITEM 11) HINGE PIN ZERKS ON BOOM AFTER ASSEMBLY, ONCE UNDER LOAD WITH BOOM ELEVATED AND AGAIN AT REST WITH BOOM SUPPORTED.

STANDARD BOOM ASSEMBLY - OPEN STOW, 3PS

ITEM	PART NO.	QTY.	DESCRIPTION
1	*	REF	SWIVEL ASSY *REFER TO TRACTOR MOUNT KIT
2	06700031	1	MAIN BOOM ARM ASSY
3	06310013	1	MAIN BOOM WLDMENT
4	06520075	2	BUSHING, 1-1/2"ID x 2-1/2"
5	TB3010	2	BUSHING, 1"ID
6	24517	1	SECONDARY BOOM ARM ASSY
7	TB1001G	1	SECONDARY BOOM WLDMENT
8	TB3010	3	BUSHING, 1"ID
9	TB1035	1	BUSHING, SPACER
10	6T3211	4	GREASE ZERK, 1/8"
11	6T3207	3	GREASE ZERK, 1/4"
12	35312	1	SET COLLAR
13	06510050	1	TRAVEL LOCK, METRIPACK COIL
14	31329	1	ADAPTER, 1/2ORB x 1/2ORB ADJ
15	TB1023	2	ROLLPIN, 7/32"
16	06501023	1	CYLINDER, 3" x 18"
17	06537021	6	ROLL PIN, 5mm
18	TB1033	3	PIN, 1" x 4"
19	TB1036	1	PIN, 1" x 4-11/16"
20	TF1143	1	PIN, LYNCH
21	21688	2	CAPSCREW, 7/16" x 3-1/4", NC
22	21677	2	NYLOCK NUT, 7/16", NC
23	6T3210	1	GREASE ZERK, 1/8" x 90°
24	TB1025	1	PIN, 1-1/2" x 12"
25	22076	1	SPACER, DECK LIFT CYL
26	06501024	1	CYLINDER, 3-1/2" x 20"
27	32810	2	ELBOW, 1/2ORB x 3/8MJ90ADJ
28	06501022	1	CYLINDER, 4" x 20"
29	06420100	1	PIN, 1-1/4" x 3-5/8"
30	06420022	1	PIN, 1-1/2" x 12-3/4"

STANDARD BOOM - OPEN STOW, 3PS HOSES

NOTES:

1. PRESSURE AND RETURN LINES ARE OPPOSITE AS SHOWN FOR STANDARD ROTATION BOOM FLAIL MOWERS.

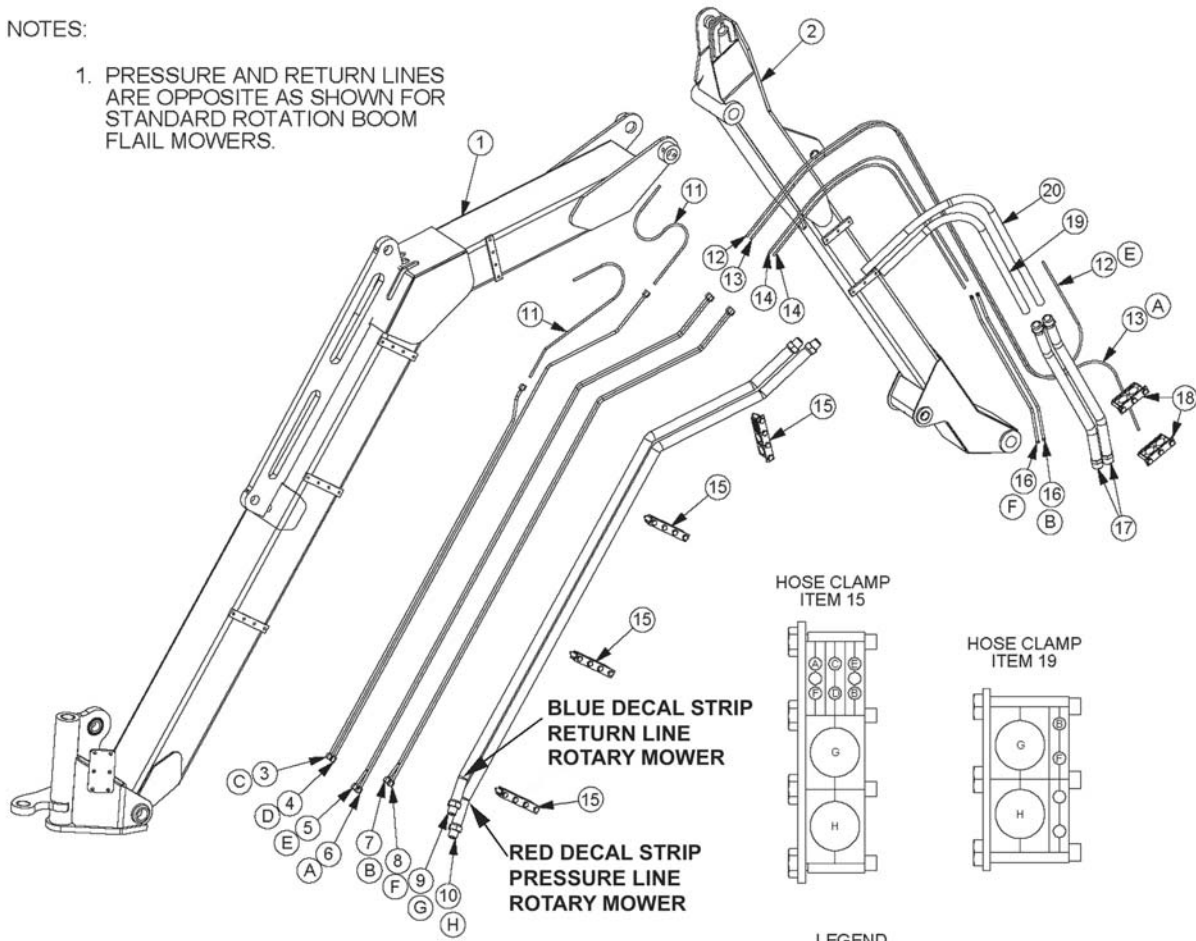

STANDARD BOOM - OPEN STOW, 3PS HOSES

ITEM	PART NO.	QTY.	DESCRIPTION
1	*	REF	MAIN BOOM *REFER TO BOOM ARM ASSY
2	*	REF	SECONDARY BOOM *REFER TO BOOM ARM ASSY
3	06506017	1	PRFRMD,5,MAIN BOOM
4	06506016	1	PRFRMD,4,MAIN BOOM
5	06506019	1	PRFRMD,7,MIAN BOOM
6	06506014	1	PRFRMD,2,MAIN BOOM
7	06506018	1	PRFRMD,6,MAIN BOOM
8	06506013	1	PRFRMD,1,MAIN BOOM
9	06506021	1	PRFRMD,9,MAIN BOOM
10	06506022	1	PRFRMD,10,MAIN BOOM
11	34052	2	HOSE,1/4" x 20"
12	34078	1	HOSE,1/4" x 48"
13	34079	1	HOSE,1/4" x 68"
14	34104	2	HOSE,1/4" x 42"
15	06505019	4	CLAMP KIT,3 SECTION
16	34102	2	TUBE,PRFRMD,SEC BOOM
17	2403306	2	TUBE,PRFRMD,SEC BOOM,HP
18	30111	2	CLAMP KIT,2 SECTION
19	24488	1	HOSE,1" x 40"
20	06500254	1	HOSE,1" x 45"

EXTENDED BOOM ASSEMBLY

LEGEND

- A - DECK ROLL CYLINDER GLAND
- B - SHIELD CYLINDER GLAND
- C - SECONDARY CYLINDER BUTT
- D - SECONDARY CYLINDER GLAND
- E - DECK ROLL CYLINDER BUTT
- F - SHIELD CYLINDER BUTT
- G - RETURN FROM MOTOR
- H - PRESSURE TO MOTOR

HOSE CLAMP
ITEM 13

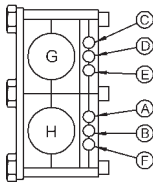

HOSE CLAMP
ITEM 14

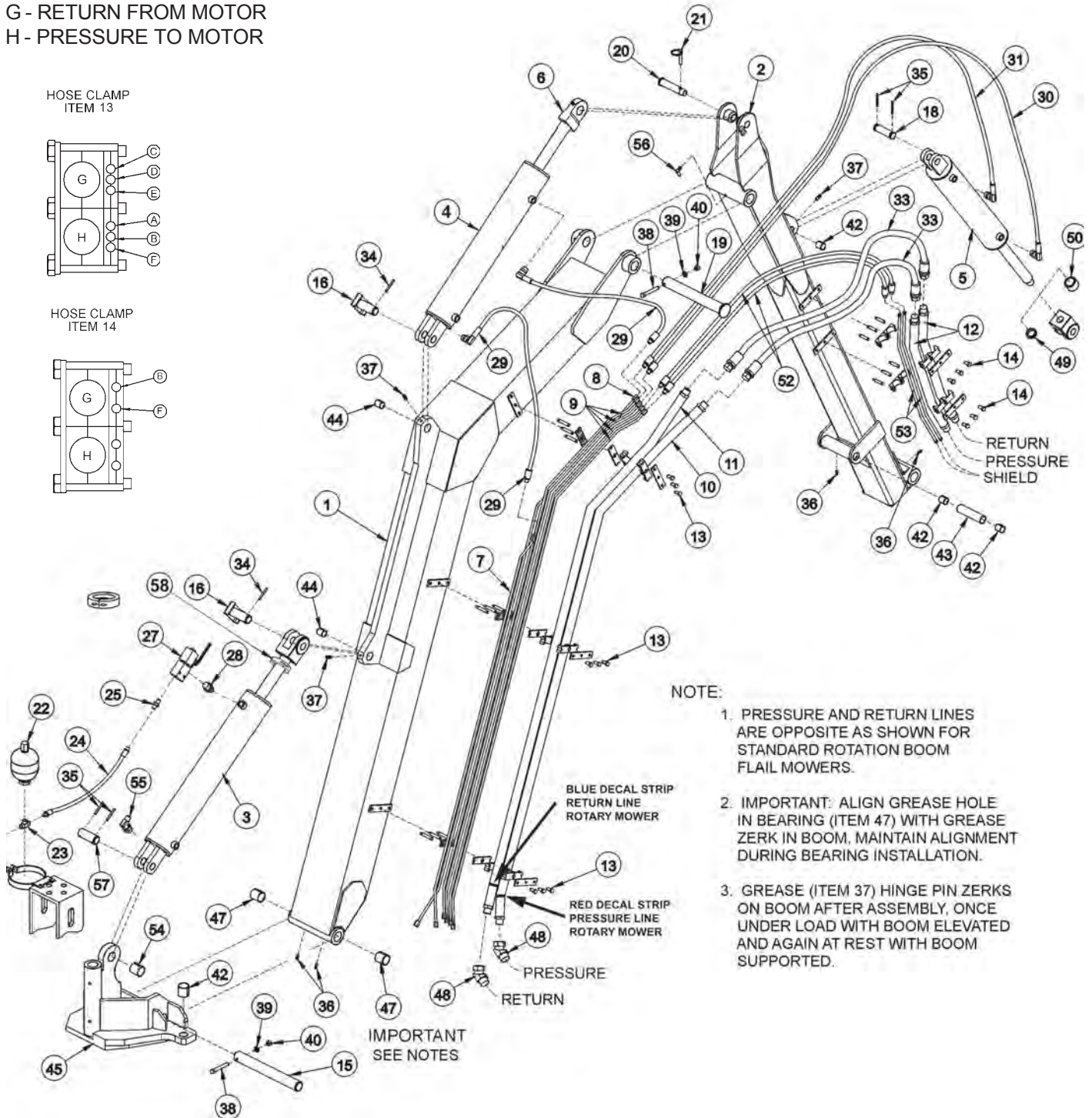
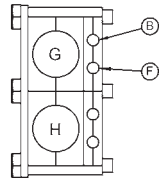

NOTE:

1. PRESSURE AND RETURN LINES ARE OPPOSITE AS SHOWN FOR STANDARD ROTATION BOOM FLAIL MOWERS.
2. IMPORTANT: ALIGN GREASE HOLE IN BEARING (ITEM 47) WITH GREASE ZERK IN BOOM, MAINTAIN ALIGNMENT DURING BEARING INSTALLATION.
3. GREASE (ITEM 37) HINGE PIN ZERKS ON BOOM AFTER ASSEMBLY, ONCE UNDER LOAD WITH BOOM ELEVATED AND AGAIN AT REST WITH BOOM SUPPORTED.

EXTENDED BOOM ASSEMBLY

ITEM	PART NO.	QTY.	DESCRIPTION
1	31845	1	MAIN BOOM WITH BUMPER PAD / BEARING
	TB1080	1	BUMPER PAD (NOT SHOWN)
	6T3954	4	POP RIVET 3/16" X 3/4" (NOT SHOWN)
2	30072C	1	SECONDARY BOOM, EXTENDED
3	06501020	1	CYLINDER 5" X 20" WELDED
4	06501022	1	CYLINDER 4" X 20" WELDED
5	06501023	1	CYLINDER 3" X 18" WELDED
6	30172	1	CLEVIS W. SPHERICAL BEARING
7	31234	1	PREFORMED TUBE #304
8	31235	1	PREFORMED TUBE #305
9	31233	4	PREFORMED TUBE #307
10	30167	1	PREFORMED TUBE MAIN BOOM PRESSURE
11	30168	1	PREFORMED TUBE MAIN BOOM RETURN
12	30169	2	PREFORMED TUBE
13	33440	3	TUBE CLAMP,MAIN BOOM (SIDE STOW)
	06505019	*	TUBE CLAMP,MAIN BOOM (OPEN STOW, 3PS)
14	30111	2	TUBE CLAMP,SECONDARY BOOM
15	TB3013C	1	PIN, SWIVEL
16	TB1045B	2	PIN, CYLINDER/HEAD
18	TB1033	1	PIN, 1" X 4" CYLINDER
19	TB1025	1	PIN, 1 1/2" X 12" BOOM PIVOT
20	TB1036	1	PIN, 1" X 4 11/16" CYLINDER
21	TF1143	1	LYNCH PIN, CYLINDER
22	24300	1	ACCUMULATOR
23	34020	1	TEE 3/8" X 3/8" X 1/2"
24	33397	1	HOSE - 1/4" X 55"
25	33271	1	ADAPTER - 1/2MJ X 1/2MOR
27	31328	1	TRAVEL LOCK
28	31329	1	ADAPTER - 1/2OR X 1/2ADJ OR
29	34052	2	HOSE - 1/4" X 20"
30	34050	1	HOSE - 1/4 X 83"
31	34051	1	HOSE - 1/4" X 63"
33	24488	2	HOSE 1" X 40"
34	6T3014	1	ROLL PIN 1/4" X 2"
35	06537021	4	ROLL PIN
36	6T3211	4	GREASE ZERK 1/8"
37	6T3207	3	GREASE ZERK 1/4"
38	21688	2	CAPSCREW 7/16" X 3 1/4"
39	21989	2	LOCKWASHER 7/16"
40	21675	2	HEX NUT 7/16"
42	TB3010	4	BUSHING
43	TB1035	1	SPACER
44	TB1044	2	BUSHING 1 1/4"
45	*	REF	SWIVEL REFER TO MAIN FRAME PARTS
46	6T3199	1	HOSE COVER 40" (NOT SHOWN)
47	32321	2	BEARING 2"
48	24724	2	ADAPTER (SIDE STOW ONLY)
49	22076	1	SPACER (USED ON THE 50" BOOM ROTARY)
50	23162	2	SPACER(USED ON FLAIL HEADS AND 60" ROTARY)
52	34104	2	HOSE 1/4" X 42"
53	34103	2	PREFORMED TUBE, 5/16" - SECONDARY BOOM
54	*	REF	SPHERICAL BEARING
55	33271	1	ELBOW 1/2MOR x 3/8MJ
56	6T3210	1	GREASE ZERK, 1/8 X 90
57	06420100	1	PIN, CYLINDER
58	06520222	1	SPACER (OPEN STOW OR 3PNT STOW ONLY)

BOOMREST ASSEMBLY - 3 POINT STOW

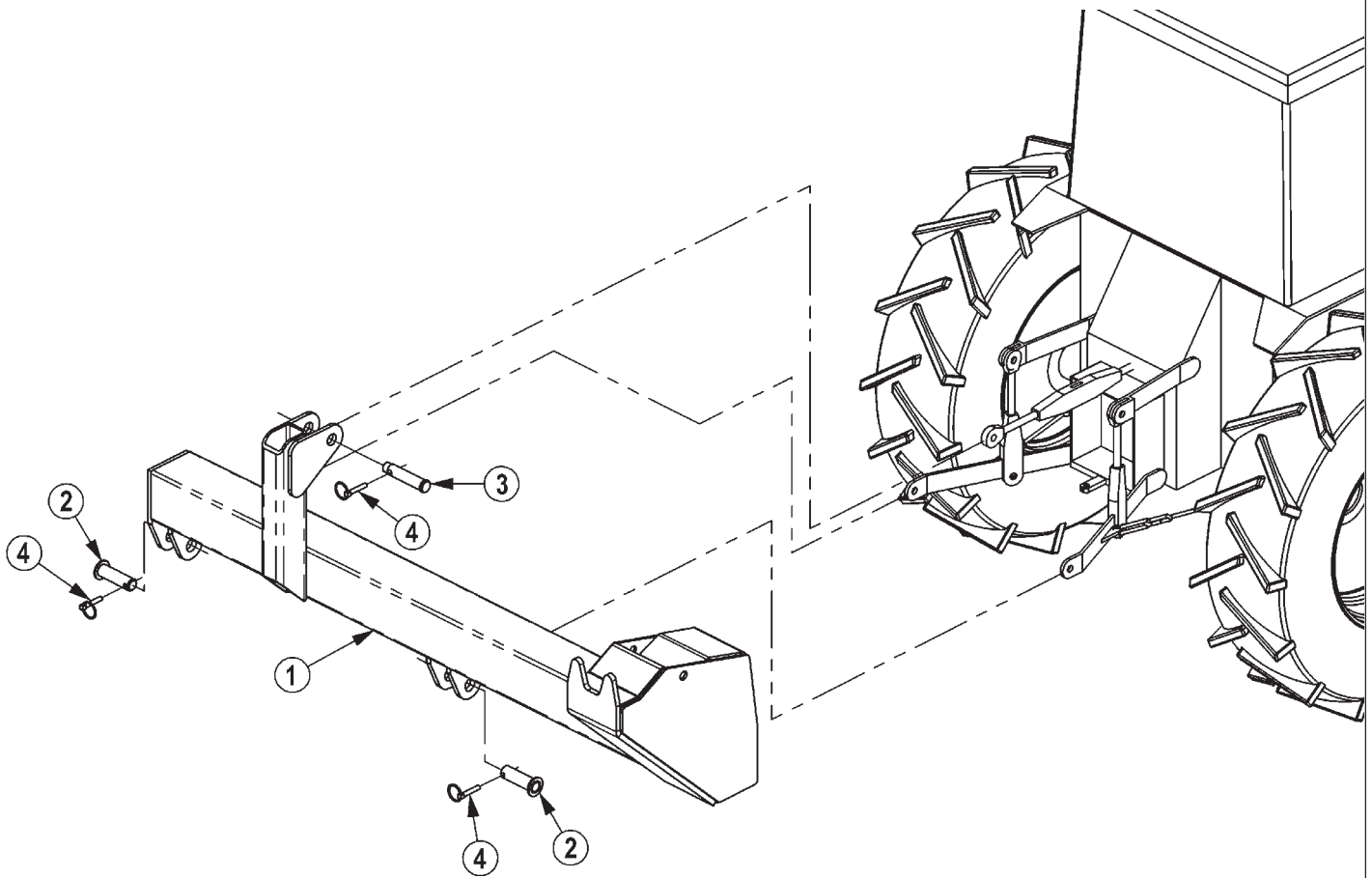

ITEM	PART NO.	QTY.	DESCRIPTION
1	06310023	1	BOOMREST,STD,3PNT
2	TF1120	2	PIN,(CAPPED),1-1/8 X 3-7/8
3	TB1036	1	PIN,SEC BOOM SWIV 1X4-11/16
4	TF1143	3	PIN,LYNCH 7/16 X 2
5	TB1023	2	ROLLPIN,7/32 X 2

HOSE SUPPORT EXTENDED BOOM

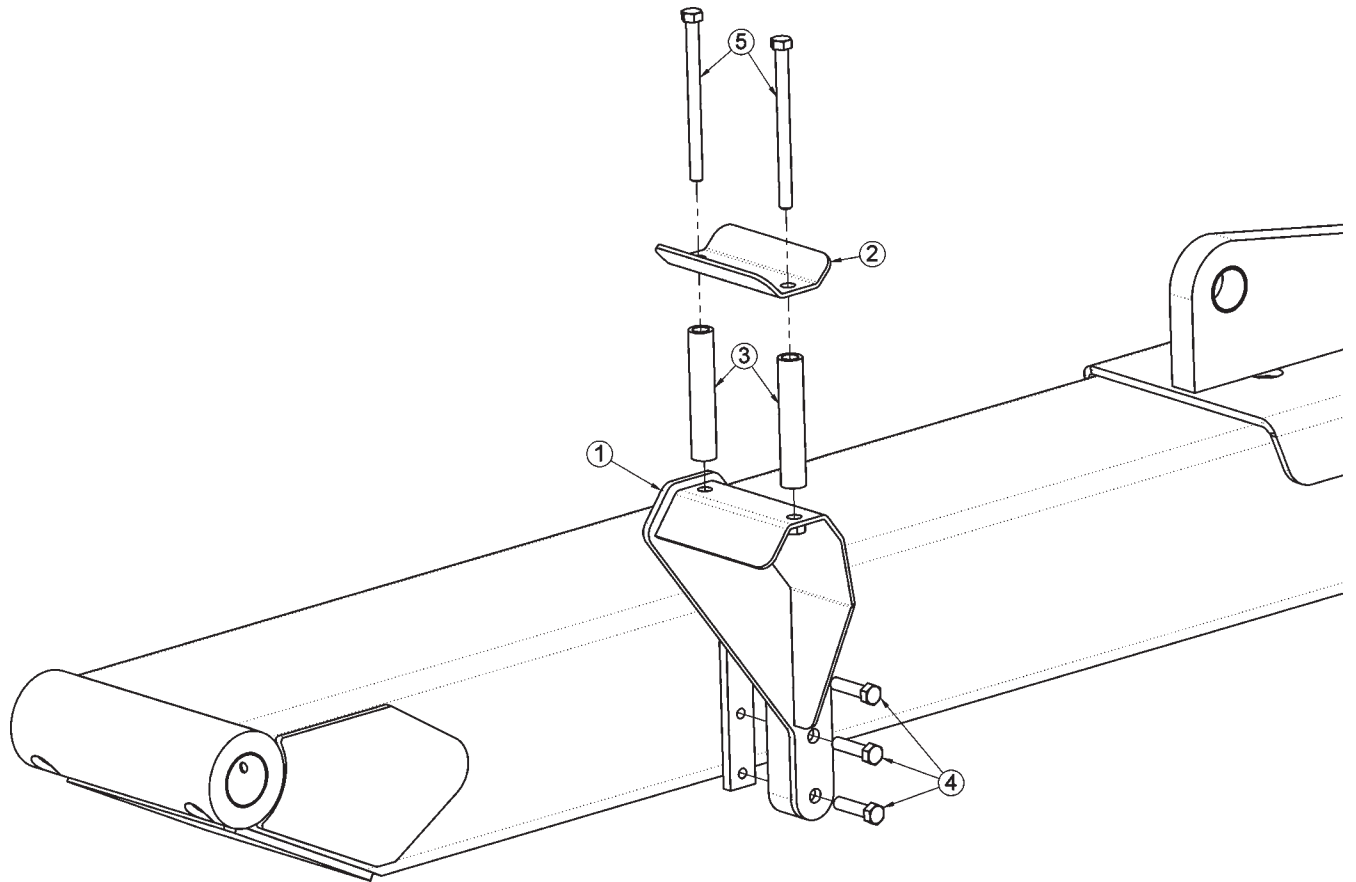

ITEM	PART NO.	QTY.	DESCRIPTION
1	06310042	1	SUPPORT,HOSES,EXT,OS,3S
2	06410608	1	CAP,SUPPORT,HOSES,EXT
3	06430075	2	SPACER,4.00x.75ODx.50ID
4	21632	3	CAPSCREW,3/8" X 1-1/2" NC
5	21644	2	CAPSCREW,3/8" X 5" NC

BOOMREST ASSEMBLY - OPEN STOW

**BOLT ON ADAPTER
FOR EXTENDED BOOM ONLY**

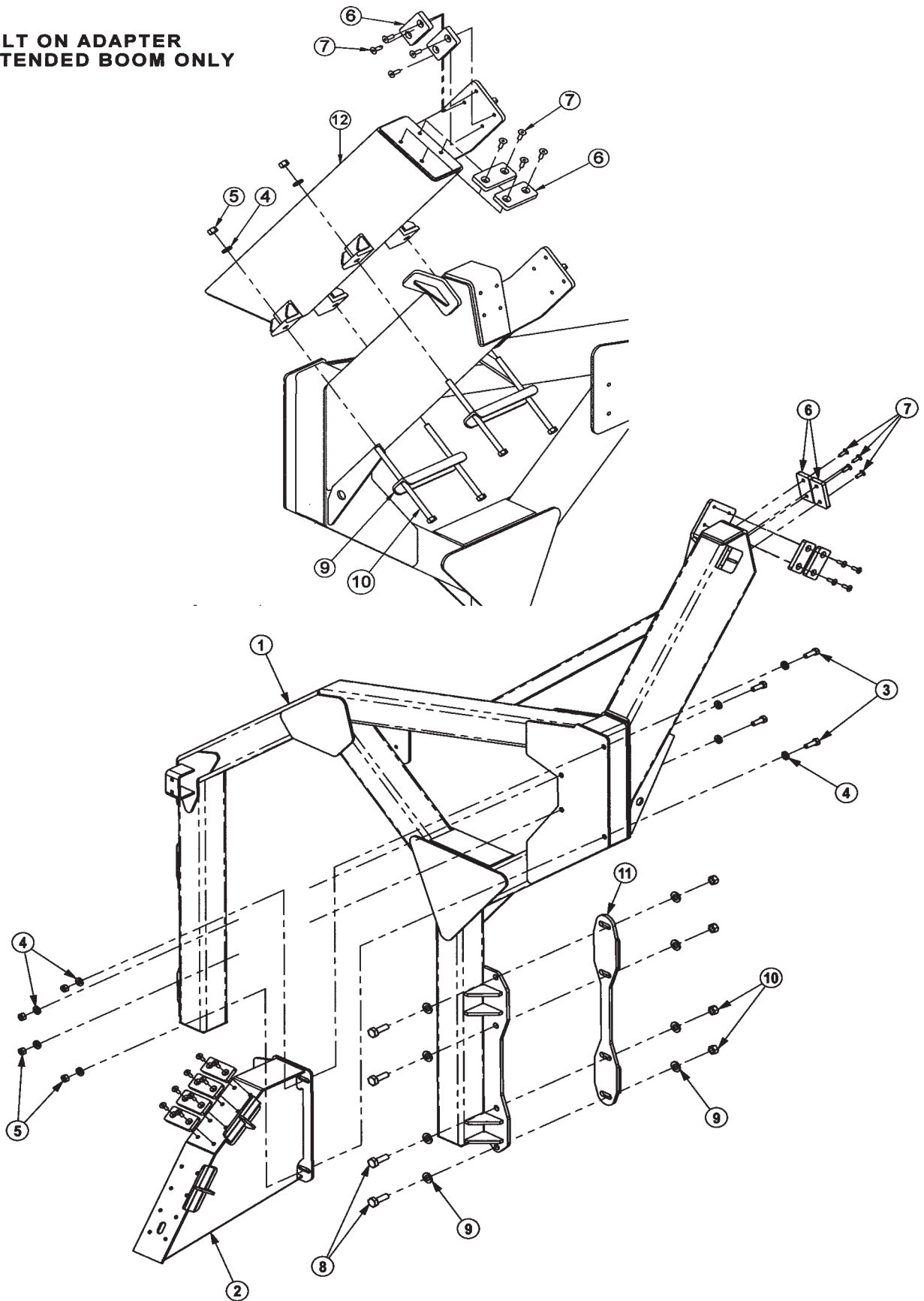

BOOMREST ASSEMBLY - OPEN STOW

STANDARD BOOM

ITEM	PART NO.	QTY.	DESCRIPTION
	06700100		
1	06310035	1	BOOMREST,BASE,RS
2	06310036	1	BOOMREST,SEC,3OS
3	21731	4	CAPSCREW,1/2 X 1-1/2 NC
4	2200406	8	FLATWASHER,1/2,SAE
5	21727	4	NYLOCK NUT,1/2 NC
6	06520078	8	STRIP,REST,SEC,1
7	28734	16	CAPSCREW,FLT/SKT HD,3/8X1NC
8	21782	8	CAPSCREW,5/8 X 1-3/4 NC
9	33764	16	FLATWASHER,5/8,GR 8,SAE
10	21775	8	HEX NUT,5/8 NC
11	*	2	REAR STOW AXLE BRACE(SEE MAIN FRAME)

EXTENDED BOOM

ITEM	PART NO.	QTY.	DESCRIPTION
	06700101		
1	06310035	1	BOOMREST,BASE,RS
2	06310036	1	BOOMREST,SEC,3OS
3	21731	4	CAPSCREW,1/2 X 1-1/2 NC
4	2200406	12	FLATWASHER,1/2,SAE
5	21727	8	NYLOCK NUT,1/2 NC
6	06520078	8	STRIP,REST,SEC,1
7	28734	16	CAPSCREW,FLT/SKT HD,3/8X1NC
8	21782	8	CAPSCREW,5/8 X 1-3/4 NC
9	33764	16	FLATWASHER,5/8,GR 8,SAE
10	21775	8	HEX NUT,5/8 NC
11	*	2	REAR STOW AXLE BRACE(SEE MAIN FRAME)
12	06310037	1	BOOMREST,EXT,MAIN,3OS
13	06410587	2	CHANNEL
14	21747	4	CAPSCREW,1/2x9,NC

BOOM ROTARY PIVOT ASSEMBLY

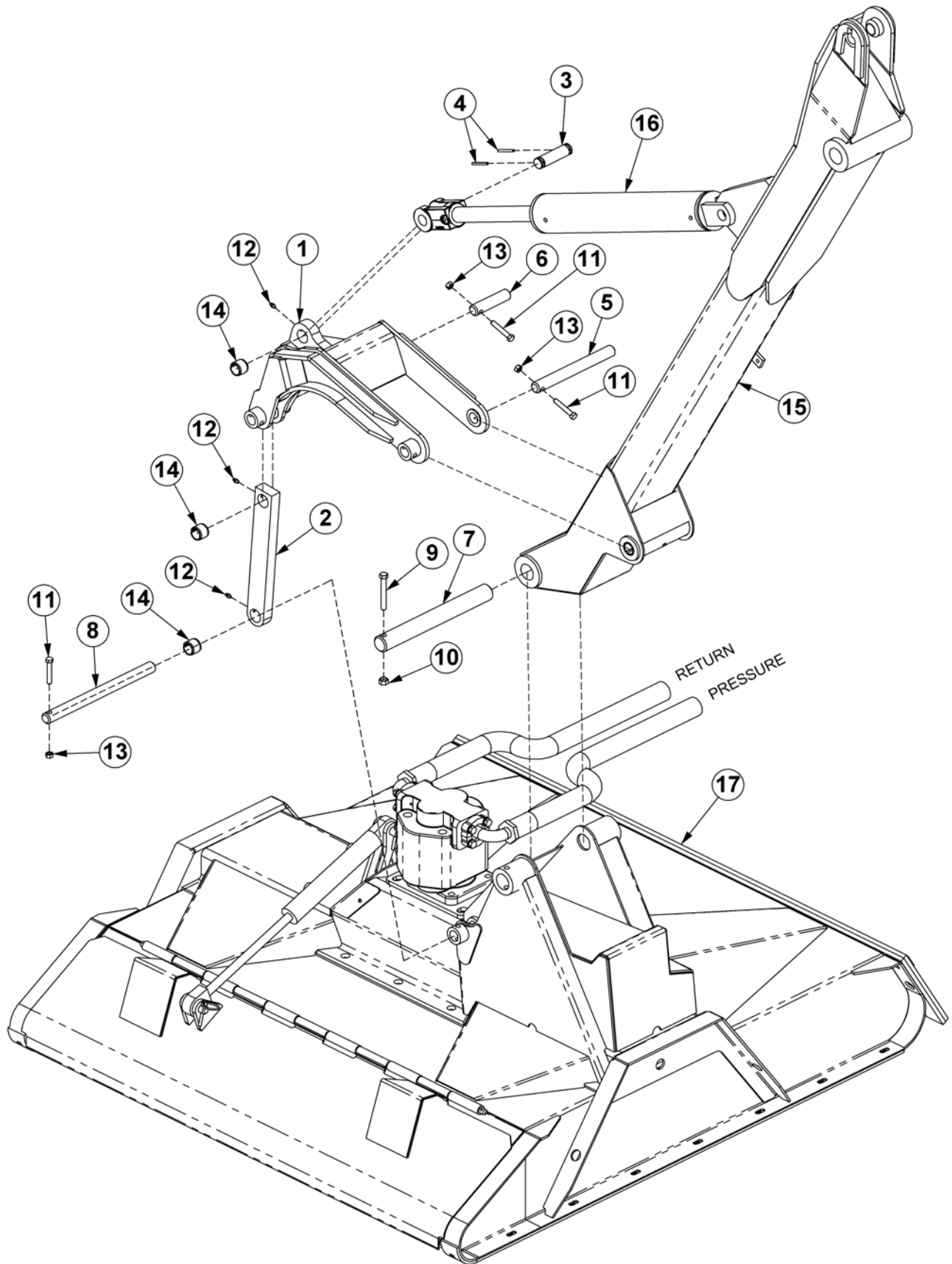

BOOM ROTARY PIVOT ASSEMBLY

ITEM	PART NO.	QTY.	DESCRIPTION
1	TB1032	1	ROTARY PIVOT ASSY
2	TB1028	1	PIVOT ARM ASSY
3	TB1033	1	PIN,CLEVIS
4	06537021	2	ROLL PIN
5	TF3097	1	PIN
6	TB1030	1	PIN
7	33985	1	PIN
8	33986	1	PIN
9	21688	1	CAPSCREW,7/16 x 3-1/4,NC
10	21677	1	NYLOCK NUT,7/16 NC
11	21635	3	CAPSCREW,3/8 x 2-1/4
12	6T3207	3	GREASE ZERK
13	21627	3	NYLOCK NUT,3/8,NC
14	TB3010	3	BUSHING
15	*	REF.	SECONDARY BOOM - REFER TO BOOM ARM ASSY
16	*	REF.	CYLINDER - REFER TO BOOM ARM ASSY
17	*	REF.	ROTARY MOWER HEAD - REFER TO ROTARY DECK

BOOM FLAIL PIVOT ASSEMBLY

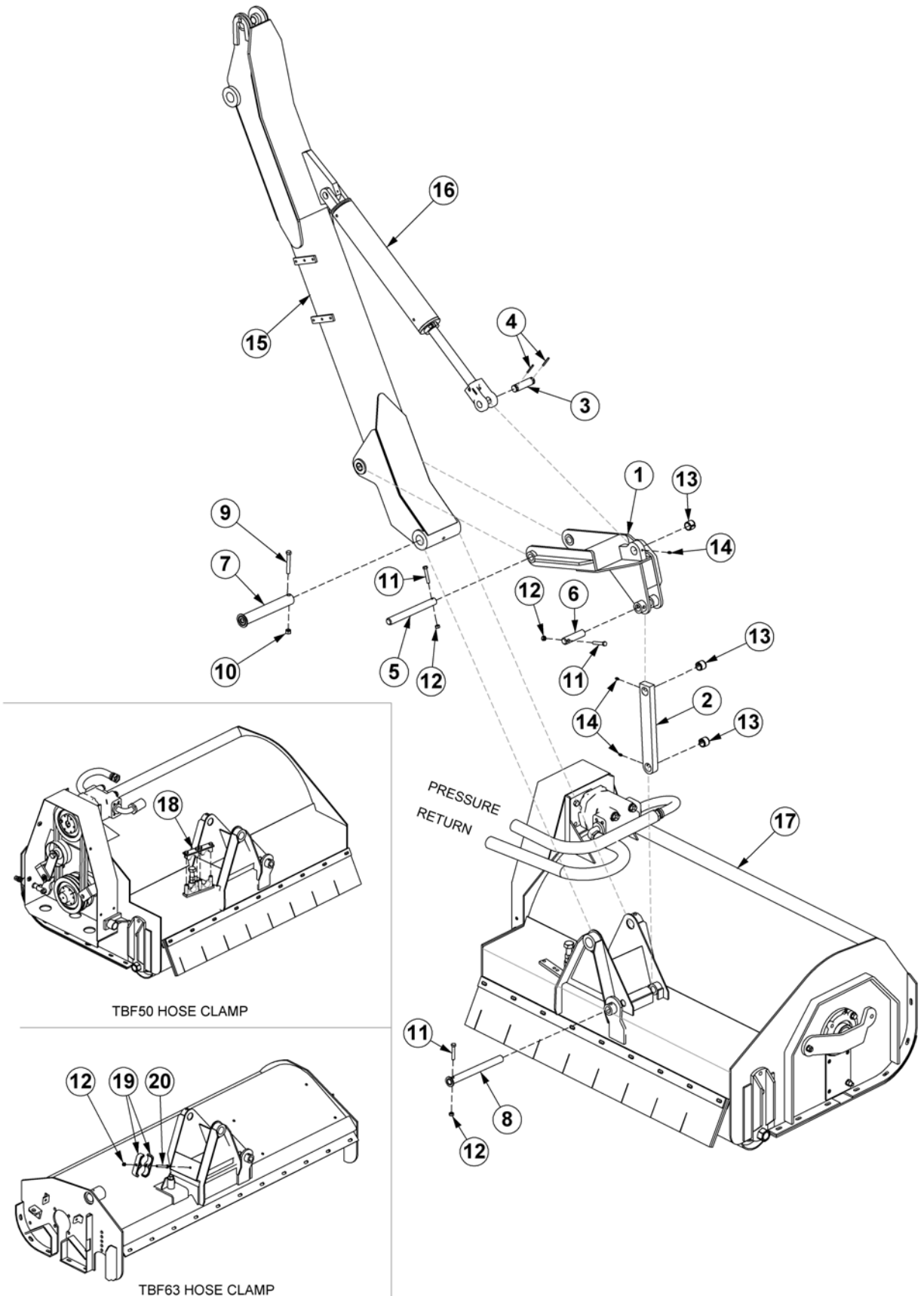

BOOM FLAIL PIVOT ASSEMBLY

ITEM	PART NO.	QTY.	DESCRIPTION
1	TF3015	1	FLAIL PIVOT ASSY
2	TB1028	1	PIVOT ARM ASSY
3	TB1033	1	PIN CLEVIS
4	06537021	2	ROLL PIN
5	TF3097	1	PIN
6	TF3090	1	PIN
7	TB1024	1	PIN
8	TB1027	1	PIN
9	21688	1	CAPSCREW 7/16" X 3 1/4"
10	21677	1	NYLOCK NUT 7/16"
11	21635	3	CAPSCREW 3/8" X 2 1/4"
12	21627	4	NYLOCK NUT 3/8"
13	TB1030	3	BUSHING
14	6T3207	3	GREASE ZERK
15	*	REF.	SECONDARY BOOM - REFER TO BOOM ARM ASSY
16	*	REF.	CYLINDER - REFER TO BOOM ARM ASSY
17	*	REF.	FLAIL MOWER HEAD - REFER TO FLAIL ASSY
18	31723	1	CLAMP KIT, TBF50 (USED ON 50" FLAIL)
**	21679	4	CAPSCREW, 7/16" x 1" NC
**	31916	4	POST, CLAMP, HOSE, 3000 PSI, FLAIL, BOOM
**	31917	4	CUSHION, CLAMP, HOSE, 3000 PSI, FLAIL, BOOM
**	31955	1	PLATE, TOP, CLAMP, TBF
19	TB3031	2	DOUBLE HOSE CLAMP (USED ON THE 63" FLAIL)
20	21638	1	CAPSCREW 3/8" X 3"

50" ROTARY MOWER ASSEMBLY

LINK TO THE SHIELD (OPTIONAL)

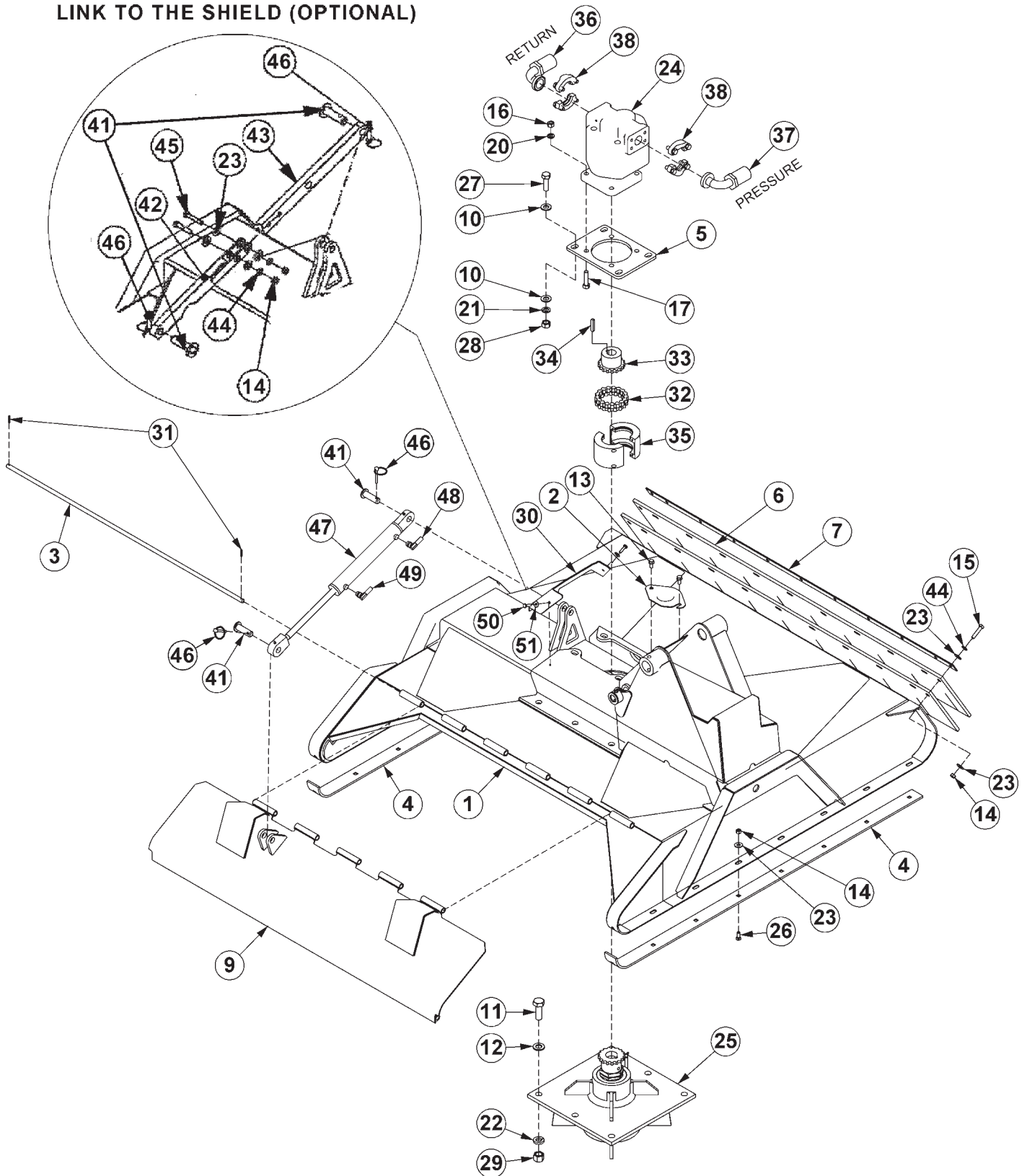

50" ROTARY MOWER ASSEMBLY

ITEM	P/N	QTY	DESCRIPTION
1	33780	1	DECK,WLDMNT,50" RTRY
2	33779	1	PLATE,COVER,KNF HOLE
3	33778	1	HINGE PIN,50" RTRY
4	33777	2	SKID SHOE,50" RTRY
5	33776	1	MOTOR MOUNT,PLATE,50" RTRY
6	33775	2	FLAP,50" RTRY
7	33774	1	FLAP RETAINER,50" RTRY
9	33754	1	SHIELD,50"RTRY
10	33764	8	FLATWASHER,5/8",GR 8,SAE
11	33879	6	CAPSCREW, 3/4 x 2 1/4,NF GR 8
12	33880	6	FLATWASHER,3/4",GR 8,SAE
13	33881	2	CAPSCREW,FLG, 3/8 x 3/4,NC
14	21625	20	HEX NUT,3/8",NC
15	21633	11	CAPSCREW, 3/8 x 1 3/4,NC
16	21725	4	HEX NUT, 1/2" NC
17	21733	4	CAPSCREW, 1/2 x 2,NC
20	06533004	4	FLATWASHER, 1/2"
21	21992	4	LOCKWASHER, 5/8
22	21993	6	LOCKWASHER,3/4",GR 8
23	22016	33	FLATWASHER,3/8"
24	06504012	1	MOTOR,(M365-1 3/4" GEAR)
25	6T1024H5	1	SPINDLE ASSY,CPLT,HD,5/8 HOLES
26	6t2270	16	PLOW BOLT,3/8" X 1" NC
27	6T2290	4	CAPSCREW,5/8x2,NF GR 8
28	6T2408	4	HEX NUT, 5/8, NF
29	6T2413	6	HEX NUT,3/4,NF,GR 8
30	06410439	1	COVER
31	6T3017	2	ROLLPIN
32	6T1029	1	COUPLER CHAIN
33	21223	1	SPROCKET
34	TF1124	1	SQUARE KEY
35	6T1033	1	COUPLER COVER WITH HARDWARE AND SEALS
36	24489	1	HOSE - RETURN (BLUE DECAL STRIP)
37	24490	1	HOSE - PRESSURE (RED DECAL STRIP)
38	TF4852	2	FLANGE KIT - #20
41	33984	2	PIN,SHIELD,50"
42	33773	1	LINK 2, SHIELD 50" RTRY (OPTIONAL)
43	33772	1	LINK, SHIELD 50" RTRY (OPTIONAL)
44	21988	11	LOCKWASHER, 3/8"
45	21634	2	CAPSCREW, 3/8" x 2, NC
46	RD1032	2	LYNCH PIN
47	33785	1	1-1/2" X 8", CYLINDER, WELDED
48	34186	1	HOSE 1/4" X 66"
49	34187	1	HOSE 1/4" X 75"
50	21530	2	CAPSCREW,1/4 x 1,NC
51	22016	2	FLATWASHER,1/4

60" ROTARY MOWER ASSEMBLY

LINK TO THE SHIELD (OPTIONAL)

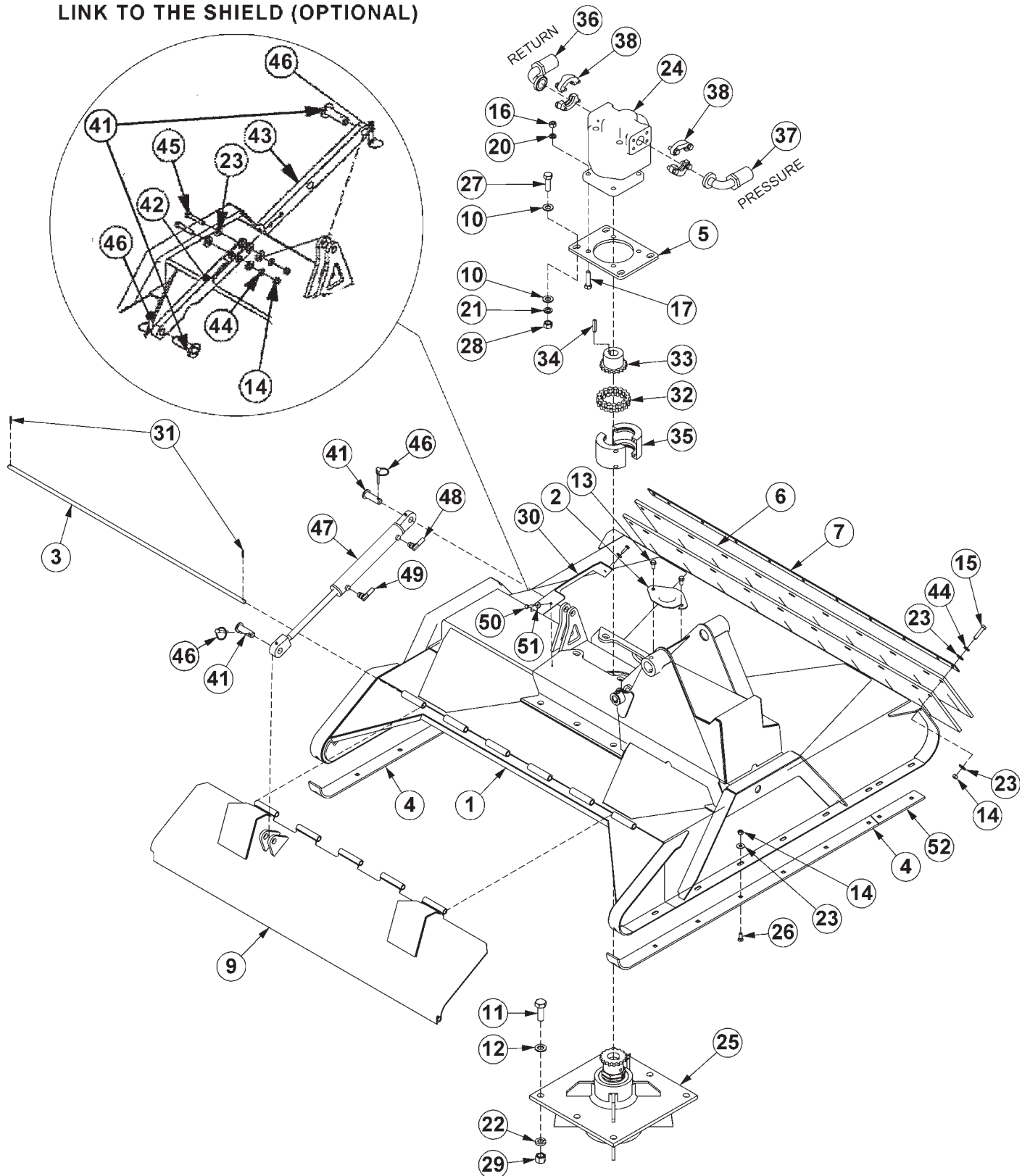

60" ROTARY MOWER ASSEMBLY

ITEM	P/N	QTY	DESCRIPTION
1	06320159	1	DECK,WLDMNT,60" RTRY
2	33779	2	PLATE,COVER,KNF HOLE
3	06420139	1	HINGE PIN,60" RTRY
4	33777	2	SKID SHOE,50" RTRY
5	33776	1	MOTOR MOUNT,PLATE,50" RTRY
6	06520238	2	FLAP,60" RTRY
7	6T0823	1	FLAP RETAINER,60" RTRY
9	06320162	1	SHIELD,60" RTRY
10	33764	8	FLATWASHER,5/8",GR 8,SAE
11	33879	6	CAPSCREW, 3/4 x 2 1/4,NF GR 8
12	33880	6	FLATWASHER,3/4",GR 8,SAE
13	33881	4	CAPSCREW,FLG, 3/8 x 3/4,NC
14	21625	33	HEX NUT,3/8",NC
15	21633	11	CAPSCREW, 3/8 x 1 3/4,NC
16	21727	4	NYLOCK NUT, 1/2" NC
17	21733	4	CAPSCREW, 1/2 x 2,NC
20	06533004	4	FLATWASHER, 1/2"
21	21992	4	LOCKWASHER, 5/8
22	21993	6	LOCKWASHER,3/4",GR 8
23	22016	44	FLATWASHER,3/8"
24	06504011	1	MOTOR
25	6T1024H5	1	SPINDLE ASSY,CPLT,HD,5/8 HOLES
26	6T2270	20	PLOW BOLT,3/8" X 1" NC
27	6T2290	4	CAPSCREW,5/8x2,NF GR 8
28	6T2408	4	HEX NUT, 5/8, NF
29	6T2413	6	HEX NUT,3/4,NF,GR 8
30	06410439	1	COVER
31	6T3017	2	ROLLPIN
32	6T1029	1	COUPLER CHAIN
33	21223	1	SPROCKET
34	TF1124	1	SQUARE KEY
35	6T1033	1	COUPLER COVER WITH HARDWARE AND SEALS
36	24489	1	HOSE - RETURN (BLUE DECAL STRIP)
37	24490	1	HOSE - PRESSURE (RED DECAL STRIP)
38	TF4852	2	FLANGE KIT - #20
41	33984	2	PIN,SHIELD,50"
42	33773	1	LINK 2, SHIELD (OPTIONAL)
43	33772	1	LINK, SHIELD (OPTIONAL)
44	21988	11	LOCKWASHER, 3/8"
45	21634	2	CAPSCREW, 3/8" x 2, NC
46	RD1032	2	LYNCH PIN
47	33785	1	1-1/2" X 8", CYLINDER, WELDED
48	34186	1	HOSE 1/4" X 66"
49	34187	1	HOSE 1/4" X 75"
50	21530	2	CAPSCREW,1/4 x 1,NC
51	22014	2	FLATWASHER,1/4
52	06401245	2	SKID SHOE,TRB60

60" BOOM ROTARY MOWER DECK ASSY

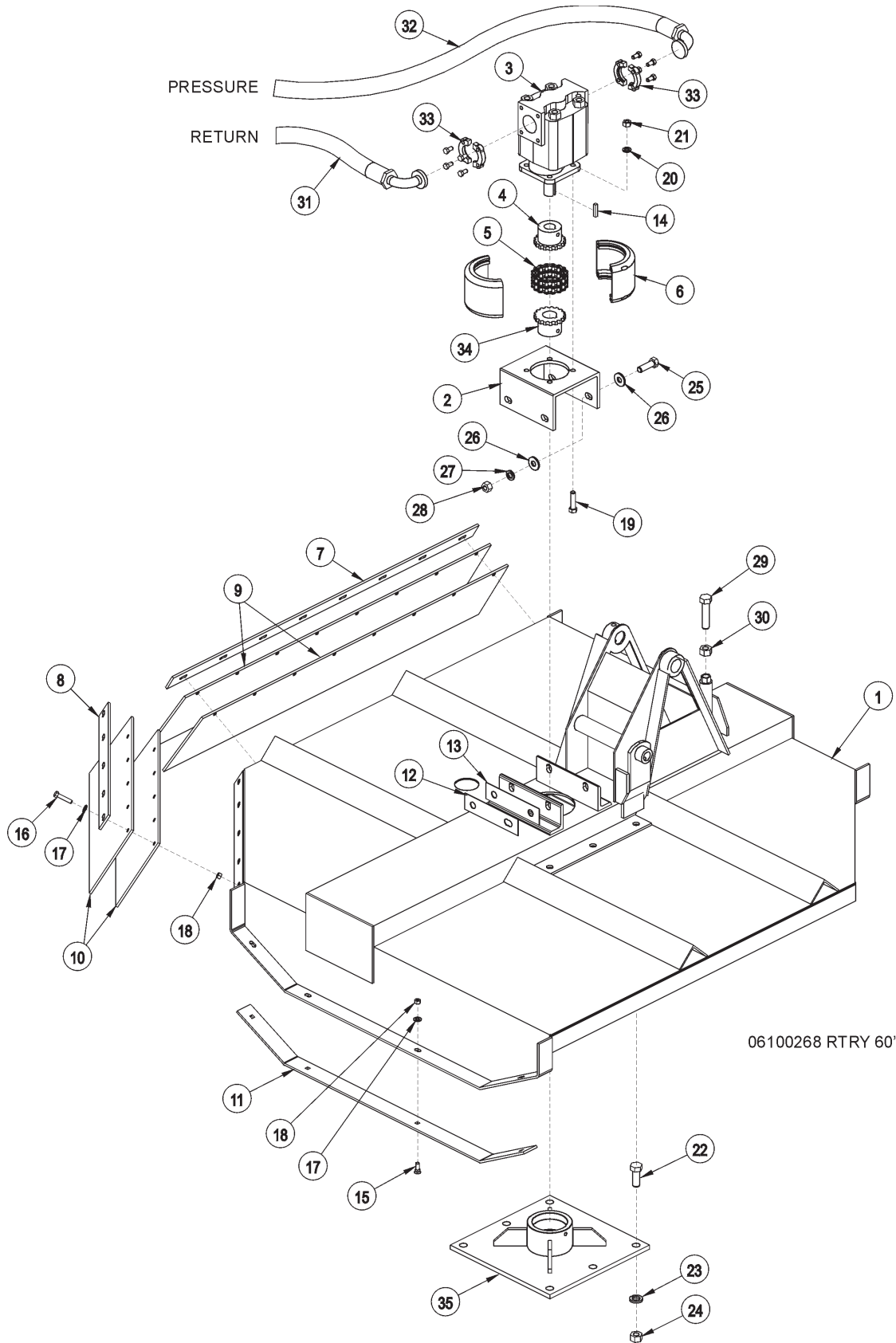

06100268 RTRY 60"

60" BOOM ROTARY MOWER DECK ASSY

ITEM	PART NO.	QTY.	DESCRIPTION
1	27575	1	60" MOWER DECK
2	6T1001	1	MOTOR BRACKET
3	06504011	1	MOTOR(M365-2 1/4GEAR)
4	21223	1	SPROCKET
5	6T1029	1	COUPLER CHAIN
6	6T1033	1	COUPLER COVER WITH HARDWARE AND SEALS
7	TB1108	1	REAR FLAP RETAINING BAR - LARGE
8	TB1107	1	REAR FLAP RETAINING BAR - SMALL
9	TB1106	2	DEFLECTOR FLAP - LARGE
10	TB1105	2	DEFLECTOR FLAP - SMALL
11	TB1104A	2	SKID SHOE
12	6T0822	3	MOTOR MOUNTING SHIM -AS REQUIRED
13	6T0822A	2	MOTOR MOUNTING SHIM -AS REQUIRED
14	TF1124	1	SQUARE KEY
15	6T2270	8	PLOW BOLT
16	21633	14	CAPSCREW 3/8" X 1 3/4"
17	22016	22	FLATWASHER 3/8"
18	21625	22	HEX NUT 3/8"
19	21733	4	CAPSCREW 1/2" X 2"
20	21990	4	LOCKWASHER 1/2"
21	21725	4	HEX NUT 1/2"
22	33879	6	CAPSCREW 3/4" X 2-1/4" NF
23	21993	6	LOCKWASHER 3/4"
24	6T2413	6	HEX NUT 3/4"
25	6T2290	4	CAPSCREW 5/8" X 2"
26	33764	8	FLATWASHER 5/8"
27	21992	4	LOCKWASHER 5/8"
28	6T2408	4	HEX NUT 5/8"
29	21837	1	CAPSCREW 3/4" X 3 1/4"
30	21825	1	HEX NUT 3/4"
31	06500154	1	HOSE, 1" X 141" - RETURN (BLUE DECAL STRIP)
32	06500155	1	HOSE, 1" X 126" - PRESSURE (RED DECAL STRIP)
33	TF4852	2	FLANGE KIT
34	*	REF.	SPROCKET - REFER TO SPINDLE ASY
35	*	REF.	SPINDLE HOUSING - REFER TO SPINDLE ASY

50" ROTARY KNIVES AND DISK

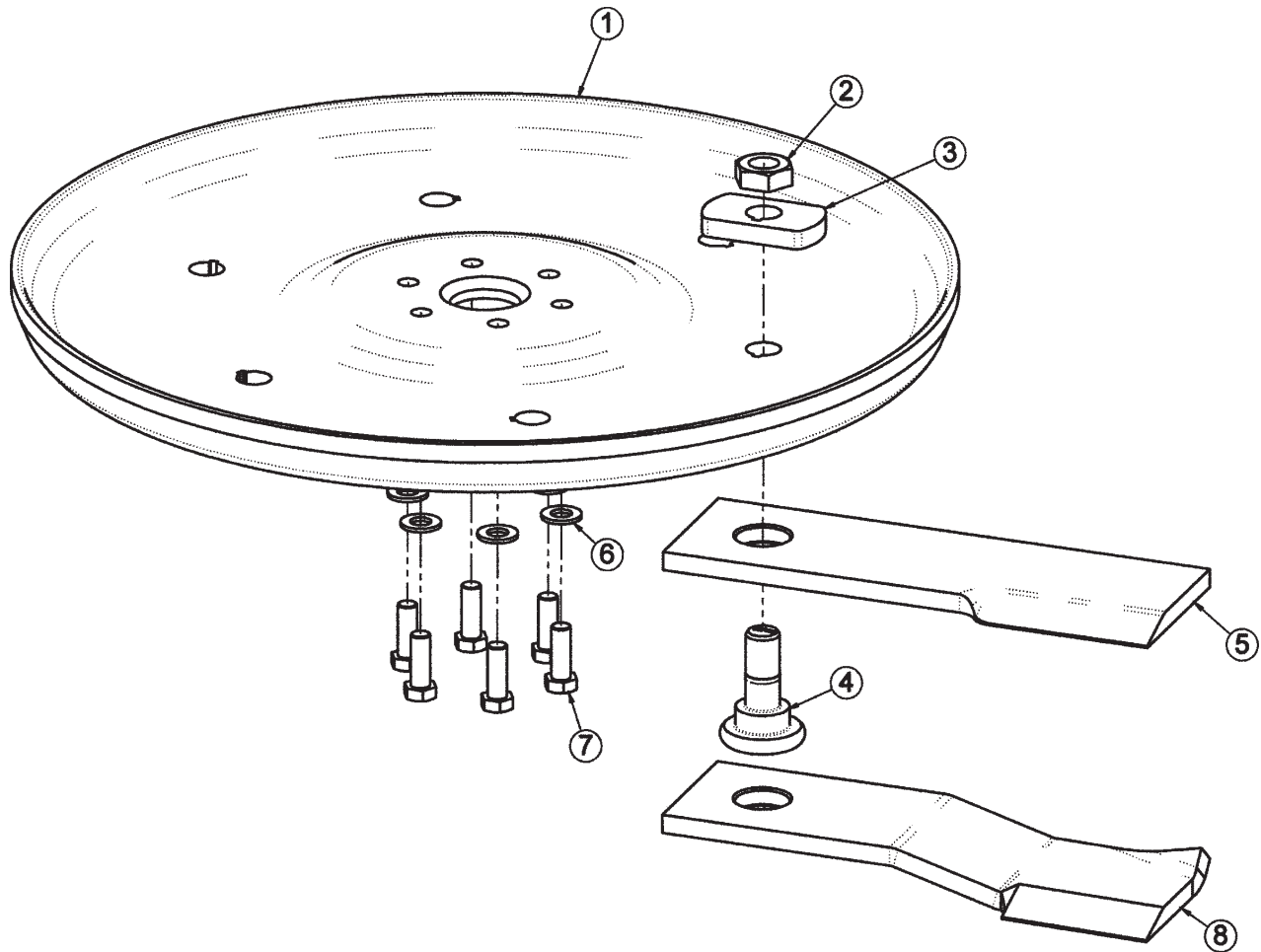

ITEM	PART NO.	QTY.	DESCRIPTION
1	06770003	1	BLADE MOUNTING DISK
2	6T1023R	2	NYLOCK HEX NUT 1-1/8"
3	34878	2	SPACER
4	06538000	2	KNIFE MOUNTING BOLT
5	06521001	2	STANDARD KNIFE
6	33764	6	FLATWASHER
7	6T2259	6	CAPSCREW
*	6T1825	1	LOCTITE - USED ON ALL DISK MOUNTING BOLTS
*	06770012	AVAIL	BOLT KIT (INCLUDE ITEMS 6, 7 & LOCTITE)
*	06700089	AVAIL	KIT, TRB50, DISK, W/BOLT KIT (INCLUDE ITEMS 1, 3 & 7)
8	06521002	2	GRASS KNIFE - OPTIONAL

50" ROTARY BLADE BAR AND KNIVES

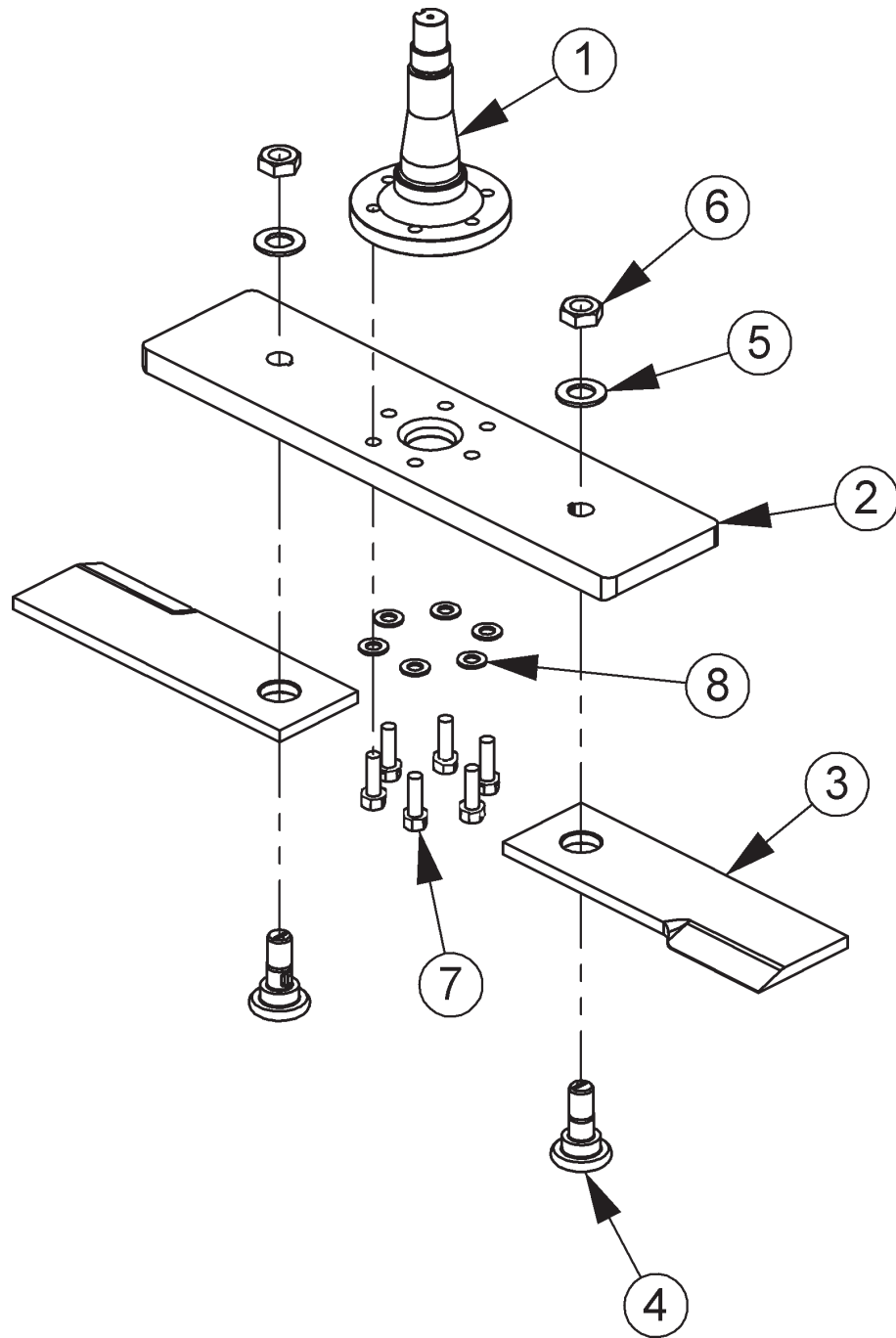

ITEM	PART NO.	QTY.	DESCRIPTION
1	PT1018H5	1	SPINDLE, 5/8 HOLES, HD, WO/TABS
2	06400388	1	BAR, BLADE, TRB
3	06521001	2	KNIFE, TRB50, 5/8
4	06538000	2	KNIFE MTG BOLT, 5/8 SHOULDER
5	06533002	2	FLATWASHER, 1-1/8, GR 8
6	6T1023R	2	KNIFE MTG NUT, 1-1/8, NF, GR 8
7	6T2259	6	CAPSCREW, 5/8x1-3/4, NF, GR 8
8	33764	6	FLATWASHER, 5/8, GR 8, SAE

60" ROTARY KNIVES AND DISK

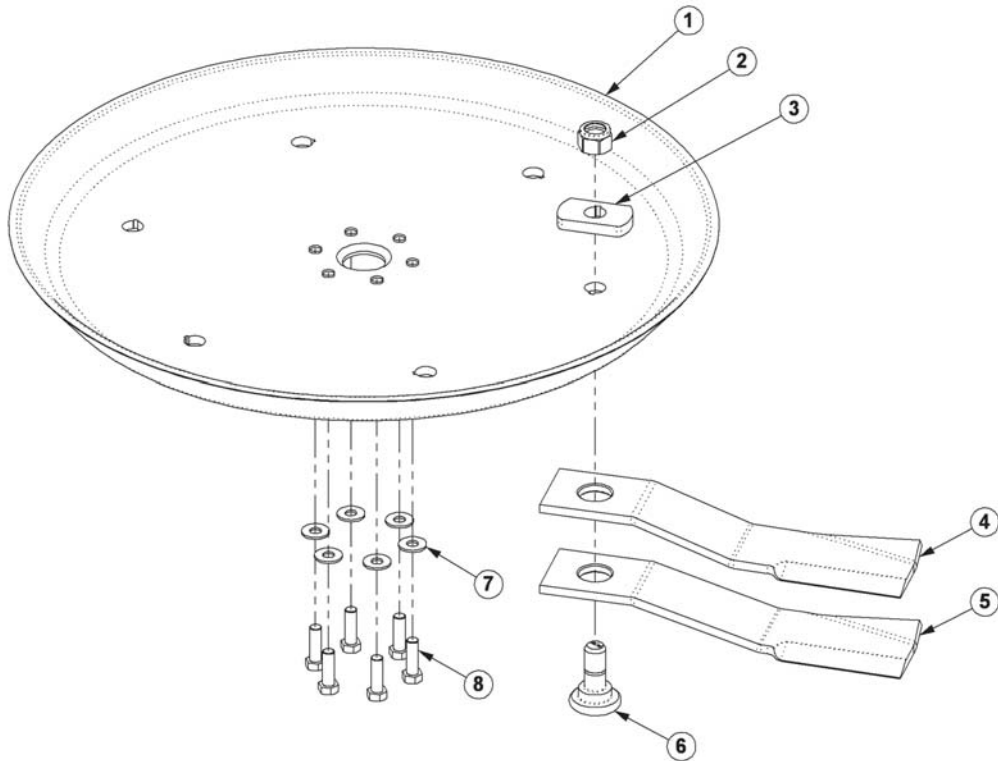

ITEM	PART NO.	QTY.	DESCRIPTION
1	34876	1	BLADE MOUNTING DISK,60"
2	6T1023R	2	NYLOCK HEX NUT 1-1/8"
3	34878	2	SPACER
4	34684	2	STANDARD KNIFE
5	34685	2	HIGH SUCTION KNIFE - OPTIONAL
6	34497	2	KNIFE MNTG BOLT 1-1/8"
7	25270	6	FLATWASHER,5/8,GR8,USS
8	6T2290	6	CAPSCREW,5/8 x 2,NF,GR8
*	6T1825	1	LOCTITE (USED ON ITEM 8)
*	27167	REF	BOLT KIT (INCLUDES ITEMS 7 & 8)
*	33893	REF	KNIFE KIT (INCLUDES ITEMS 2,4 & 6)

60" ROTARY BLADE BAR AND KNIVES

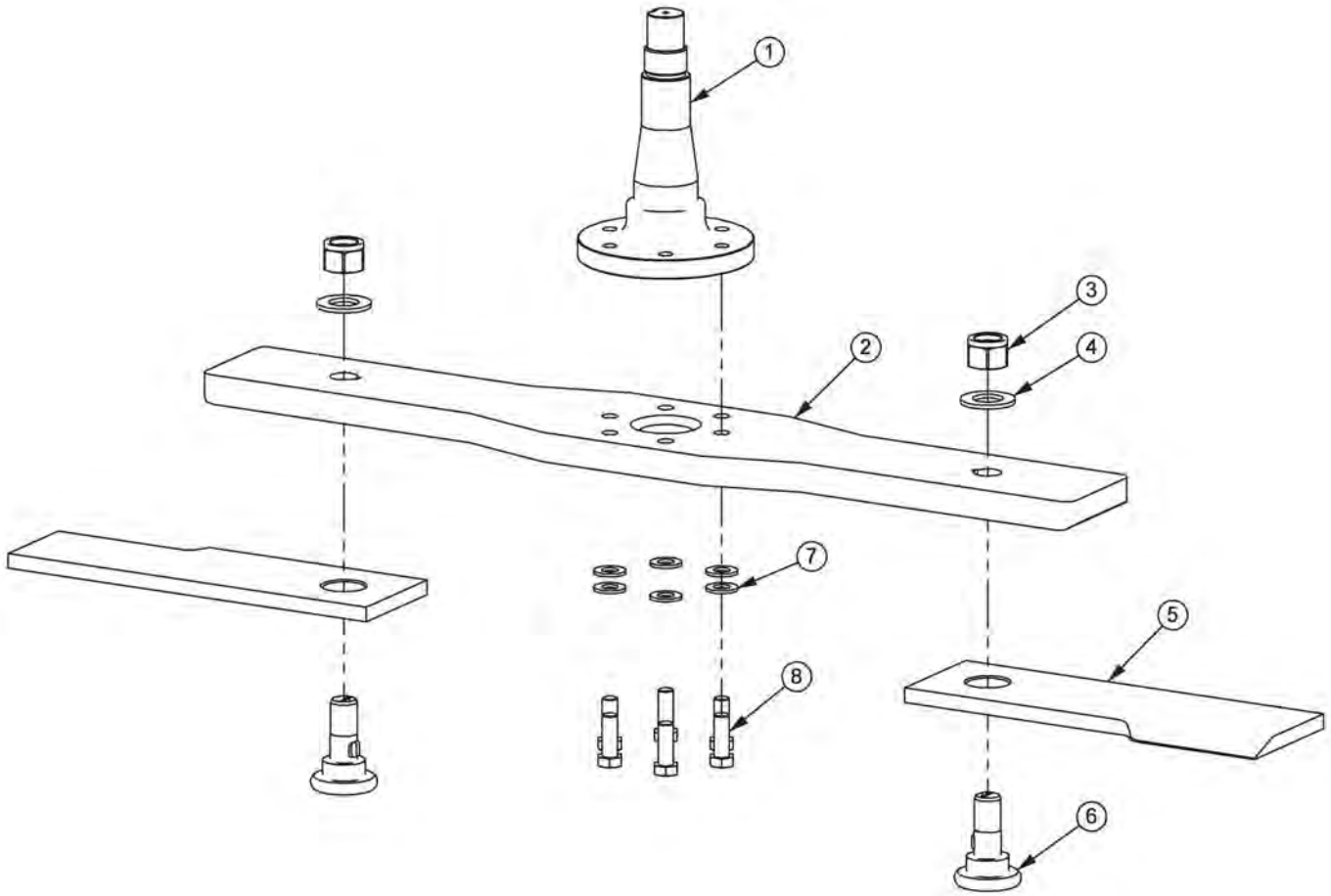

ITEM	PART NO.	QTY.	DESCRIPTION
1	PT1018H5	1	SPINDLE
2	06400690	1	BAR, BLADE, RTRY60
3	6T1023R	2	KNIFE MTG NUT, 1-1/8, NYLOCK, NF
4	06533002	2	FLATWASHER, 1-1/8, GR8
5	06521001	2	KNIFE, TRB50, 5/8
6	06538000	2	KNIFE MTG BOLT, 5/8 SHOULDER
7	33764	6	FLATWASHER, 5/8, GR 8, SAE
8	6T2259	6	CAPSCREW, 5/8 x 1-3/4, NF, GR8

50" FLAIL DRIVE ASSEMBLY

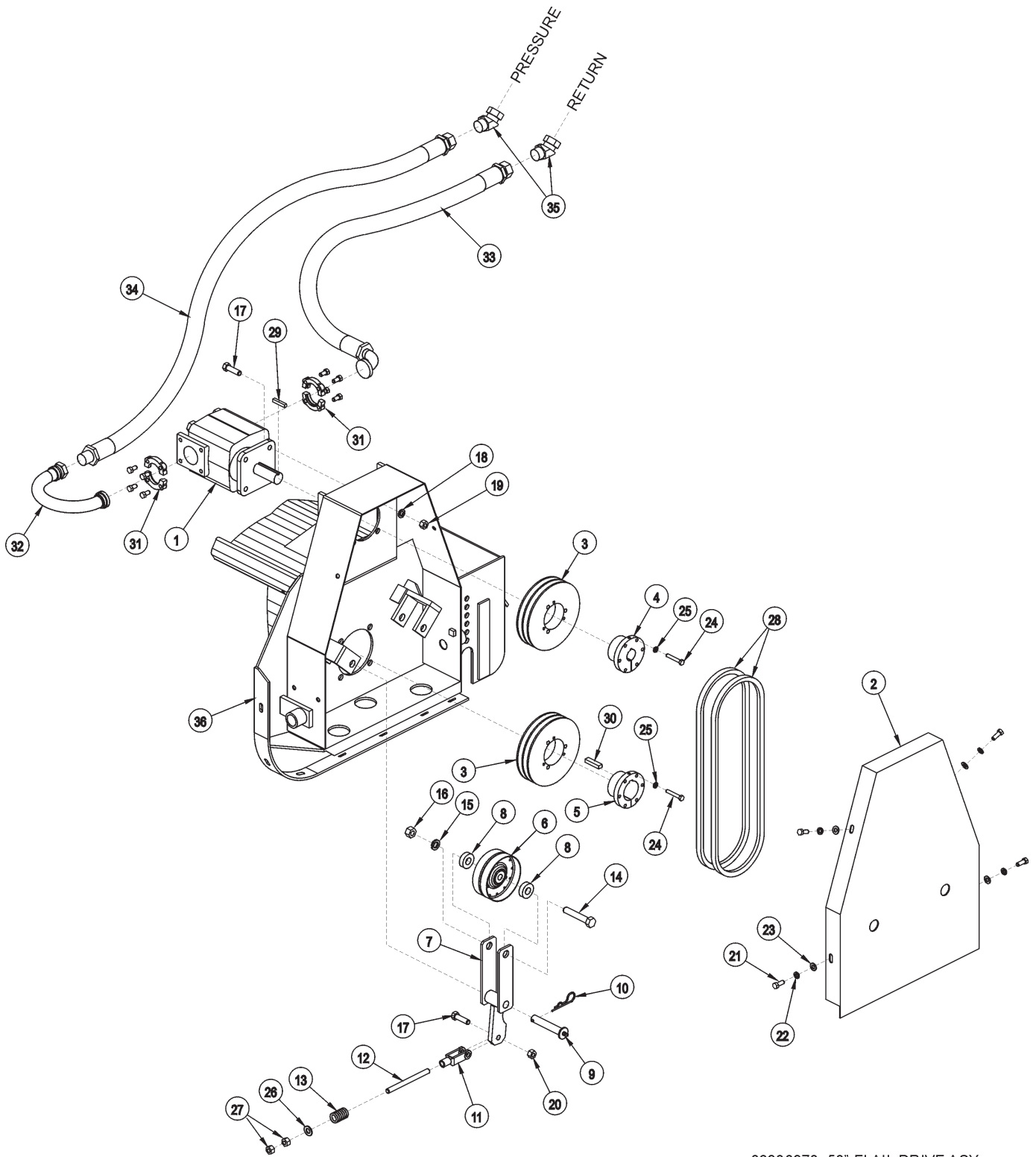

06200270 50" FLAIL DRIVE ASY

50" FLAIL DRIVE ASSEMBLY

ITEM	PART NO.	QTY.	DESCRIPTION
1	06504013	1	CURRENT MOTOR,(M350-1 3/4" GEAR)
	23174	1	ORIGINAL MOTOR,(M350-1 3/4" GEAR)
2	TF3006	1	BELT GUARD
3	TF3043	2	SHEAVE
4	TF3013	1	BUSHING
5	TF3011	1	BUSHING
6	TF3034	1	IDLER PULLEY
7	TF3205	1	IDLER ARM
8	TF3206	2	IDLER PULLEY SPACER
9	TF3605	1	IDLER ARM PIN WITH ZERK
10	6T3004	1	R - CLIP
11	PT3611A	1	CLEVIS
12	32481	1	THREADED ROD
13	TF3620	1	COMPRESSION SPRING
14	21789	1	CAPSCREW 5/8" X 3 1/2"
15	21992	1	LOCKWASHER 5/8"
16	21775	1	HEX NUT 5/8"
17	21732	5	CAPSCREW 1/2" X 1 3/4"
18	21990	4	LOCKWASHER 1/2"
19	21725	4	HEX NUT 1/2"
20	6T2418	1	LOCK NUT 1/2"
21	21630	4	CAPSCREW 3/8" X 1"
22	21988	4	LOCKWASHER 3/8"
23	22016	4	FLATWASHER 3/8"
24	21584	6	CAPSCREW 5/16" X 2"
25	21987	6	LOCKWASHER 5/16"
26	27938	1	FLATWASHER 1/2"
27	21700	2	HEX NUT 1/2" NF
28	TF3021	2	BELT
29	TF1125	1	SQUARE KEY
30	TF1025	1	SQUARE KEY MOTOR
31	TF4852	2	FLANGE KIT
32	31124	1	PREFORMED TUBE
33	31218	1	HOSE - RETURN
34	31219	1	HOSE - PRESSURE
35	24724	2	SWIVEL FITTING
36	*	REF.	CUTTER HEAD - REFER TO CUTTER HEAD ASY

50" FLAIL CUTTER SHAFT ASSEMBLY

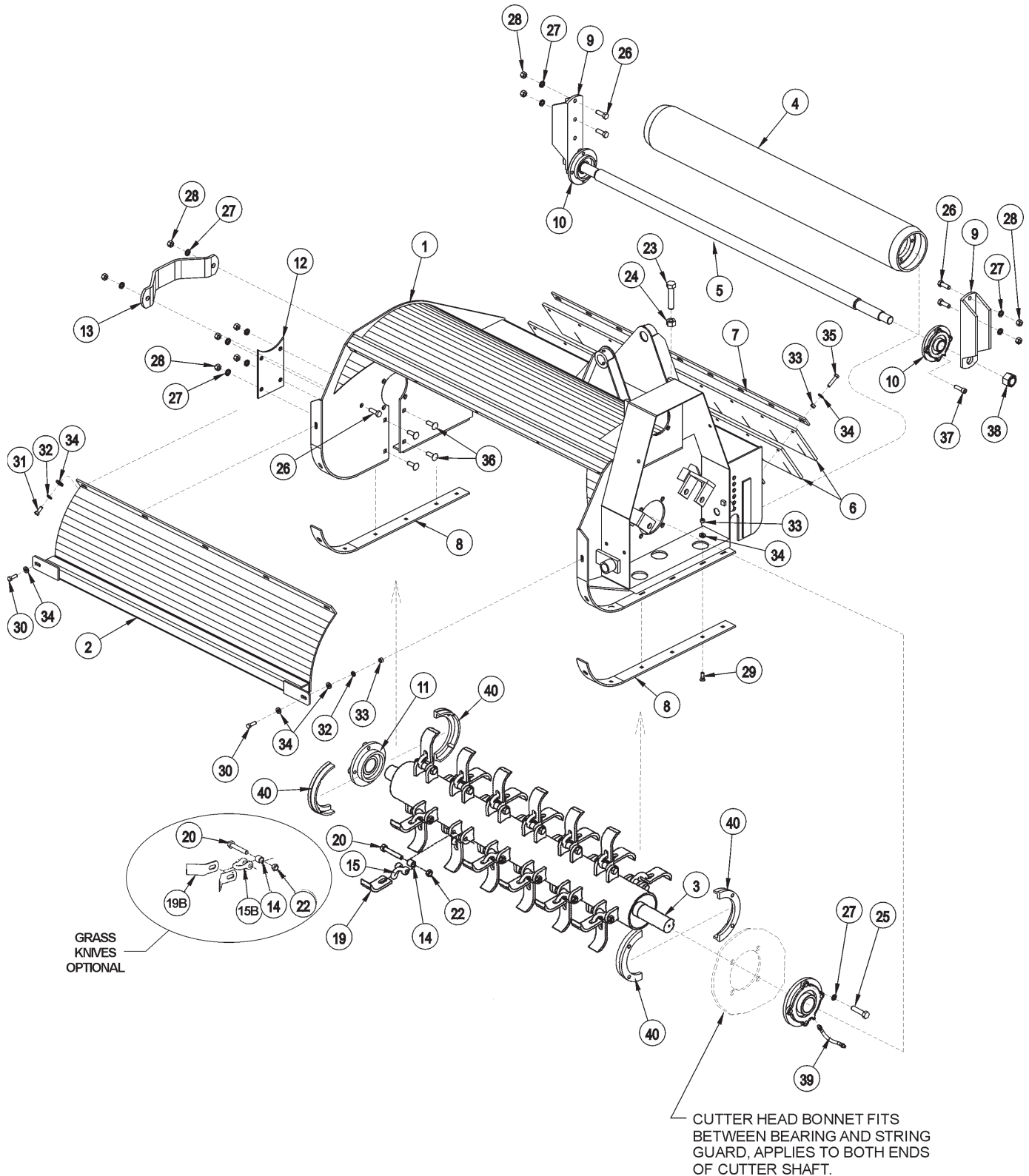

06200487 50" FLAIL CUTTER ASY

50" FLAIL CUTTER SHAFT ASSEMBLY

ITEM	PART NO.	QTY.	DESCRIPTION
	34787	AVAIL	FLAIL, BOOM,50, BRUSH,CPLT ASSY
	34789	AVAIL	FLAIL, BOOM,50, GRASS,CMPLT ASSY
1	TF3003F	1	CUTTER HEAD BONNET
2	TF3004	1	FRONT SHIELD
3	34783	AVAIL	TBF50,BRUSH,KNIFE ASSY
3A	34784	AVAIL	TBF50,GRASS,KNIFE ASSY
4	TF3405	1	GROUND ROLLER
5	TF3406	1	GROUND ROLLER TIE ROD
6	TB1006A	2	DEFLECTOR FLAP
7	TB1008	1	FLAP RETAINING BAR
8	TF3001	2	SKID SHOE
9	TF3407	2	GROUND ROLLER ADJUSTMENT BRACKET
10	TF1022	2	FLANGE BEARING 1 3/8"
11	TF1018	2	FLANGE BEARING 2 3/16"
12	TF3007A	1	COVER PLATE
13	TF1040	1	CUTTER SHAFT GUARD
14	41725.01	24	BUSHING,1ODX5/8ID
15	34782	24	CLEVIS,BRUSH
15B	34781	24	CLEVIS,GRASS
19	34780	24	BRUSH KNIFE STANDARD
19B	33714	48	HD KNIFE - OPTIONAL
20	34786	24	CAPSCREW 9/16" X 3 5/8"
22	6T2419	24	HEX NUT 9/16"
23	21838	1	CAPSCREW 3/4" X 3 1/2"
24	21825	1	HEX NUT 5/8"
25	06530218	8	CAPSCREW 1/2" X 1 3/4"
26	21731	6	CAPSCREW 1/2" X 1 1/2"
27	21990	18	LOCKWASHER 1/2"
28	21725	10	HEX NUT 1/2"
29	6T2270	12	PLOWBOLT 3/8" X 1"
30	21631	2	CAPSCREW 3/8" X 1 1/4"
31	21630	5	CAPSCREW 3/8" X 1"
32	21988	7	LOCKWASHER 3/8"
33	21625	23	HEX NUT 3/8"
34	22016	30	FLATWASHER 3/8"
35	21633	9	CAPSCREW 3/8" X 1 3/4"
36	6T7031D	4	PLOW BOLT 1/2" X 1 1/2"
37	6T2330	8	CAPSCREW 7/16" X 1 1/2" SOCKET HEAD
38	6T1023R	2	NYLOCK NUT 1 1/8" NF
39	TF1032	1	FLANGE BEARING GREASE HOSE
40	31204	2 SETS	STRING GUARD SET (2 PIECES PER SET)

63" FLAIL DRIVE ASSEMBLY

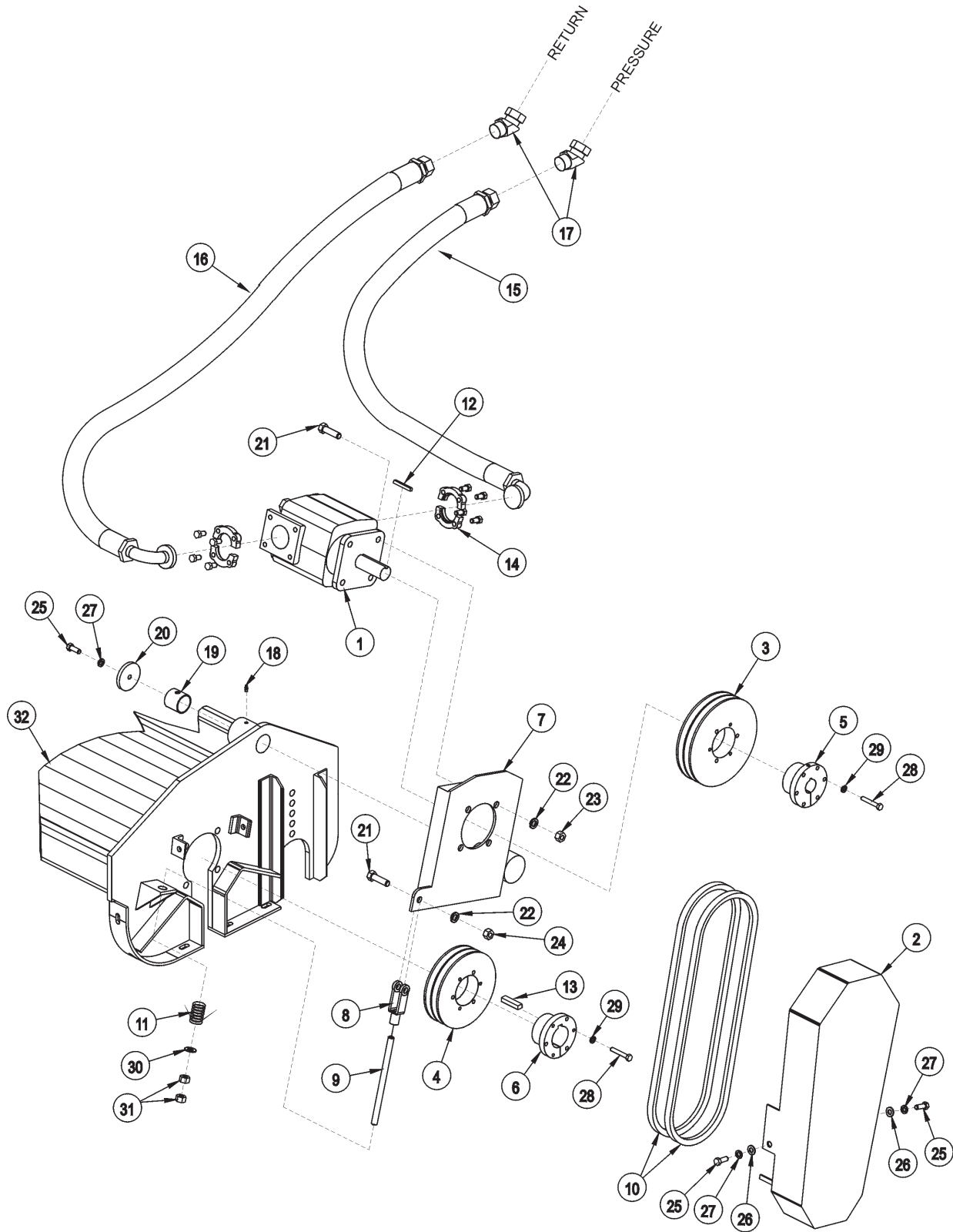

06200271 63" FLAIL DRIVE ASY

63" FLAIL DRIVE ASSEMBLY

ITEM	PART NO.	QTY.	DESCRIPTION
1	06504013	1	CURRENT MOTOR(M350-1 3/4 GEAR)
	23174	1	ORIGINAL MOTOR(M350-1 3/4 GEAR)
2	28703B	1	BELT GUARD
3	TF3044	1	UPPER SHEAVE
4	TF3040	1	LOWER SHEAVE
5	TF3013	1	BUSHING
6	28723	1	BUSHING
7	28679B	1	MOTOR CHANNEL
8	PT3611A	1	CLEVIS
9	40496	1	THREADED ROD
10	28702	2	BELT
11	TF3620A	1	TENSIONER SPRING
12	28572	1	SQUARE KEY
13	TF1025	1	SQUARE KEY
14	TF4852	2	FLANGE KIT
15	30308	1	HOSE,1 X 69(FJX X20FLG90) - PRESSURE
16	30309	1	HOSE,1 X 78(FJX X20FLG90) - RETURN
17	24724	2	SWIVEL FITTING
18	TF1033	1	GREASE ZERK
19	27580	1	BUSHING
20	28682	1	MOTOR CHANNEL WASHER
21	21732	5	CAPSCREW 1/2" X 1 3/4"
22	21990	5	LOCKWASHER 1/2"
23	21725	4	HEX NUT 1/2"
24	21727	1	NYLOCK NUT 1/2"
25	21630	3	CAPSCREW 3/8" X 1"
26	22016	2	FLATWASHER 3/8"
27	21988	3	LOCKWASHER 3/8"
28	21584	6	CAPSCREW 5/16" X 2"
29	21987	6	LOCKWASHER 5/16"
30	27938	1	FLATWASHER 1/2"
31	21700	2	HEX NUT 1/2" NF
32	*	REF.	CUTTER HEAD - REFER TO CUTTER HEAD ASY

63" FLAIL ASSEMBLY

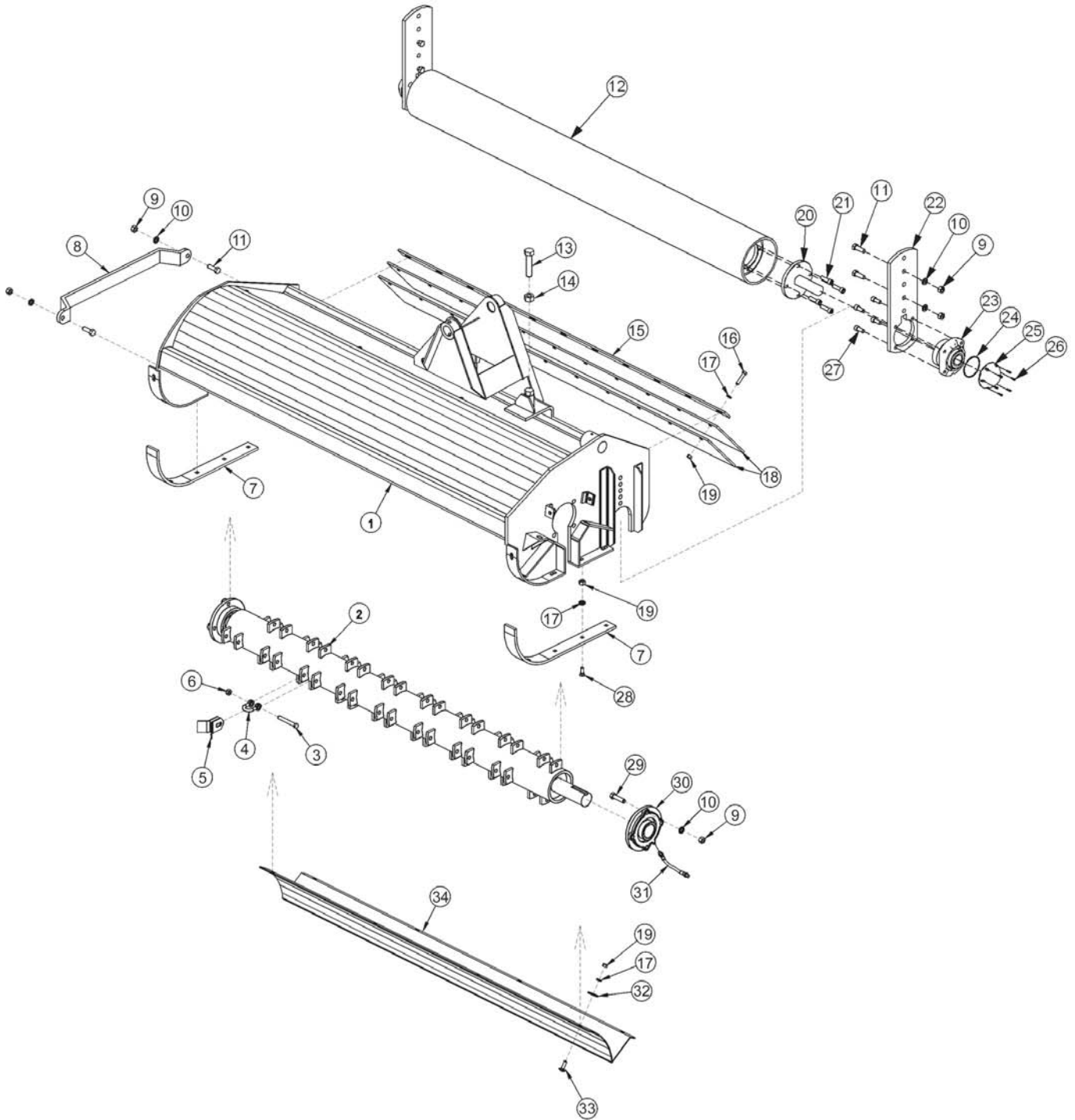

63" FLAIL ASSEMBLY

ITEM	PART NO.	QTY.	DESCRIPTION
*	06200271	AVAIL.	FLAIL,BOOM,63,GRASS,CPLT ASSY
1	28659H	1	CUTTER HEAD BONNET
*	28743	1	CUTTER SHAFT / KNIFEASY STANDARD GRASS
2	28642C	1	CUTTER SHAFT,63,STD
3	TF1021B	36	FLAIL KNIFE MOUNTING BOLT
4	TF1020	36	FLAIL KNIFE MOUNTING CLEVIS
5	33713	72	FLAIL KNIFE - STANDARD
6	21677	36	NYLOCK NUT
7	28086A	2	SKID SHOE
8	27975A	1	CUTTER SHAFT GUARD
9	21725	14	HEX NUT 1/2"
10	21990	14	LOCKWASHER 1/2"
11	21731	6	CAPSCREW 1/2" X 1 1/2"
12	28650A	1	GROUND ROLLER
13	21838	1	CAPSCREW 3/4" X 3 1/2"
14	21825	1	HEX NUT 3/4"
15	28700	1	FLAP RETAINING BAR
16	21633	11	CAPSCREW 3/8" X 1 3/4"
17	21988	28	LOCKWASHER 3/8"
18	28701	2	DEFLECTOR FLAP
19	21625	28	HEX NUT 3/8"
20	TF1045B	2	GROUND ROLLER STUB SHAFT
21	6T2330	8	CAPSCREW 7/16" X 1 1/2" SOCKET HEAD
22	28735	2	ADJUSTABLE ROLLER BRACKET
23	06520028	2	BEARING,FLANGE,1-3/8",GROUND ROLLER
24	06520029	2	O-RING
25	06520027	2	CAP,BEARING,GROUND ROLLER
26	06530001	12	CAPSCREW ,SKT HD,8-32 X 1/2",SS
27	6T2331	8	CAPSCREW,SKT HD,7/16" X 1"
28	6T2270	10	PLOW BOLT 3/8" X 1 1/4"
29	21733	8	CAPSCREW,1/2" X 2"
30	28683	2	FLANGE BEARING
31	TF1032	1	FLANGE BEARING GREASE HOSE
32	6T2615	7	FENDER WASHER,3/8"
33	6T2283	7	CARRIAGE BOLT,3/8" X 1"
34	28665A	1	BAFFLE (INSIDE UPPER REAR OF CUTTER HEAD)

3" x 10" WELDED CYLINDER PARTS (06501021)

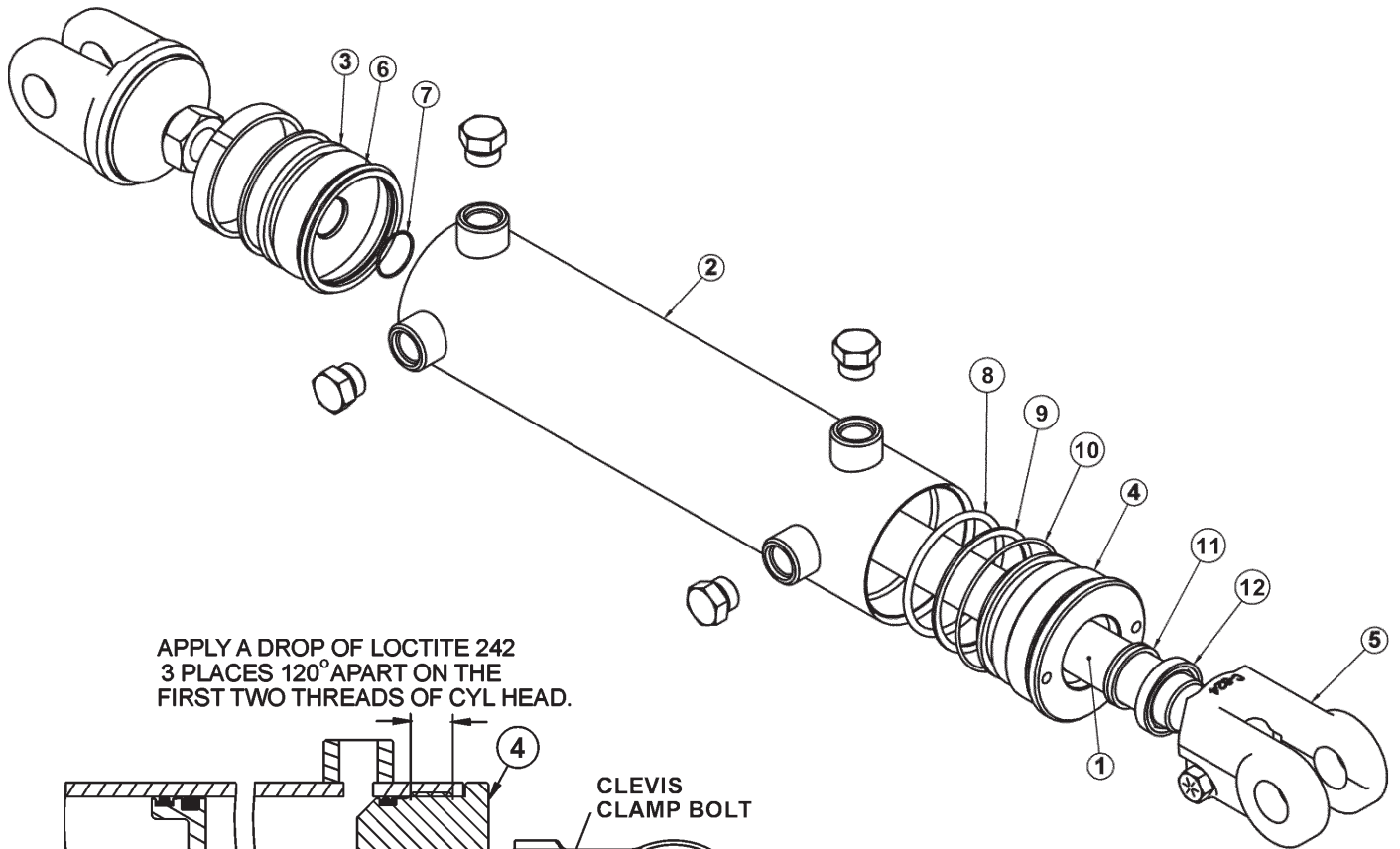

APPLY A DROP OF LOCTITE 242
3 PLACES 120° APART ON THE
FIRST TWO THREADS OF CYL HEAD.

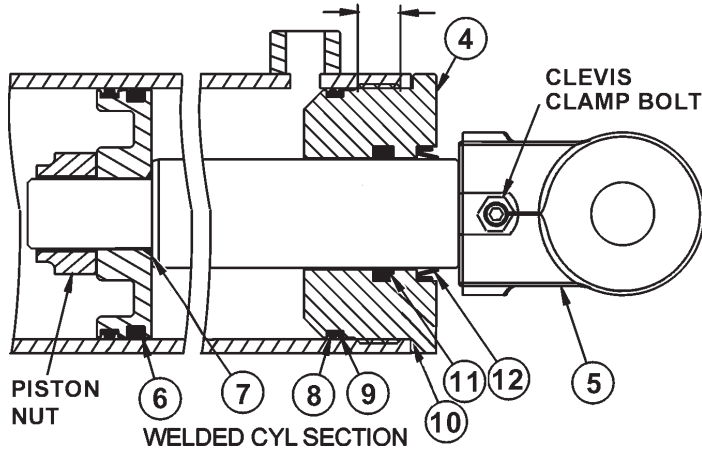

PISTON NUT
06501572

TORQUE
210 ± 5 FT. LB

CLEVIS CLAMP BOLT
3/8-16 UNC

TORQUE
26 - 30 FT. LB

WARNING - MECHANICAL FASTENERS MUST BE TORQUED TO RECOMMENDED SPECIFICATIONS DURING REPAIR TO PREVENT PERSONAL INJURY OR EQUIPMENT DAMAGE.

ITEM	PART NO.	QTY.	DESCRIPTION
*	06501021	AVAIL	HYDRAULIC CYLINDER COMPLETE
1	06501550	1	ROD
2	06501551	1	TUBE WELDMENT
3	06501552	1	PISTON
4	06501553	1	CYLINDER HEAD
5	06501554	1	CLEVIS
	06501555	AVAIL	SEAL REPAIR KIT (ITEM 6 THROUGH ITEM 12)

NOTE - ALL SEALS AND WEAR RINGS MUST BE PURCHASED IN COMPLETE SEAL REPAIR KIT.

3" x 18" WELDED CYLINDER PARTS (06501023)

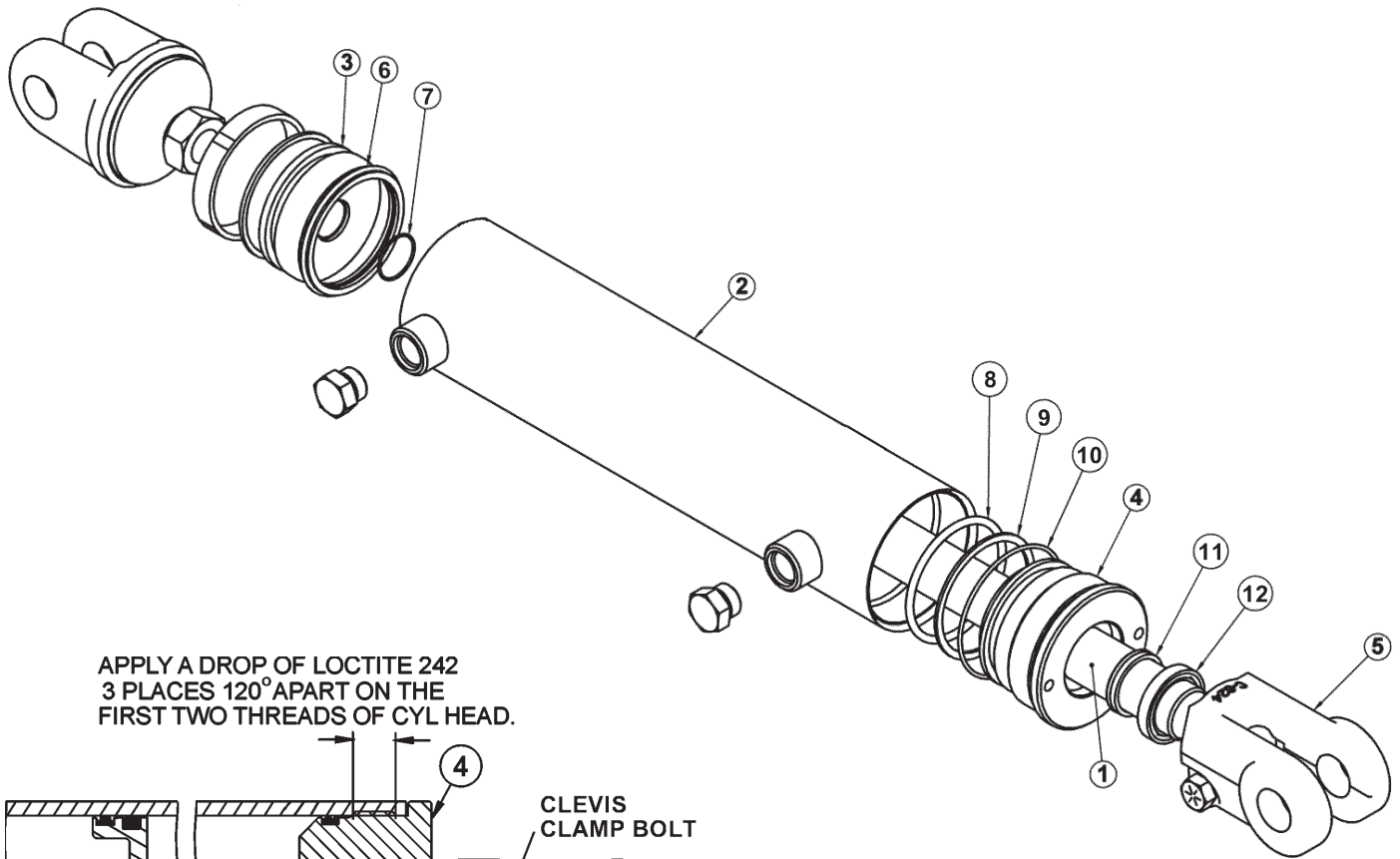

APPLY A DROP OF LOCTITE 242
3 PLACES 120° APART ON THE
FIRST TWO THREADS OF CYL HEAD.

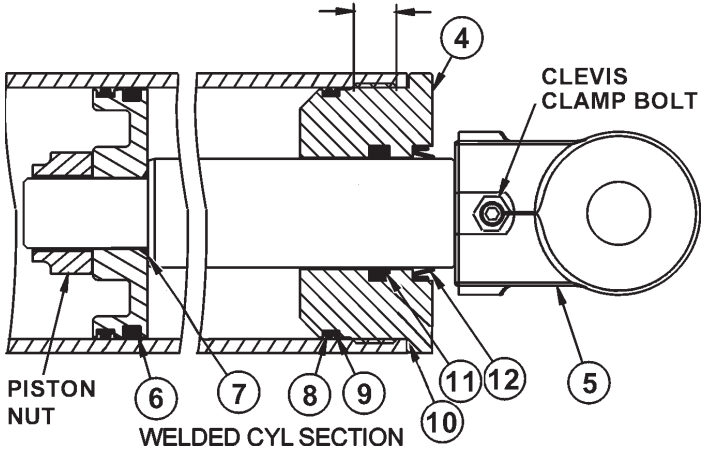

PISTON NUT
06501572

TORQUE
210 ± 5 FT. LB

CLEVIS CLAMP BOLT
3/8-16 UNC

TORQUE
26 - 30 FT. LB

WARNING - MECHANICAL FASTENERS MUST BE TORQUED TO RECOMMENDED SPECIFICATIONS DURING REPAIR TO PREVENT PERSONAL INJURY OR EQUIPMENT DAMAGE.

ITEM	PART NO.	QTY.	DESCRIPTION
*	06501023	AVAIL	HYDRAULIC CYLINDER COMPLETE
1	06501561	1	ROD
2	06501562	1	TUBE WELDMENT
3	06501552	1	PISTON
4	06501563	1	CYLINDER HEAD
5	06501554	1	CLEVIS
	06501564	AVAIL	SEAL REPAIR KIT (ITEM 6 THROUGH ITEM 12)

NOTE - ALL SEALS AND WEAR RINGS MUST BE PURCHASED IN COMPLETE SEAL REPAIR KIT.

3-1/2" x 20" WELDED CYLINDER PARTS (06501024)

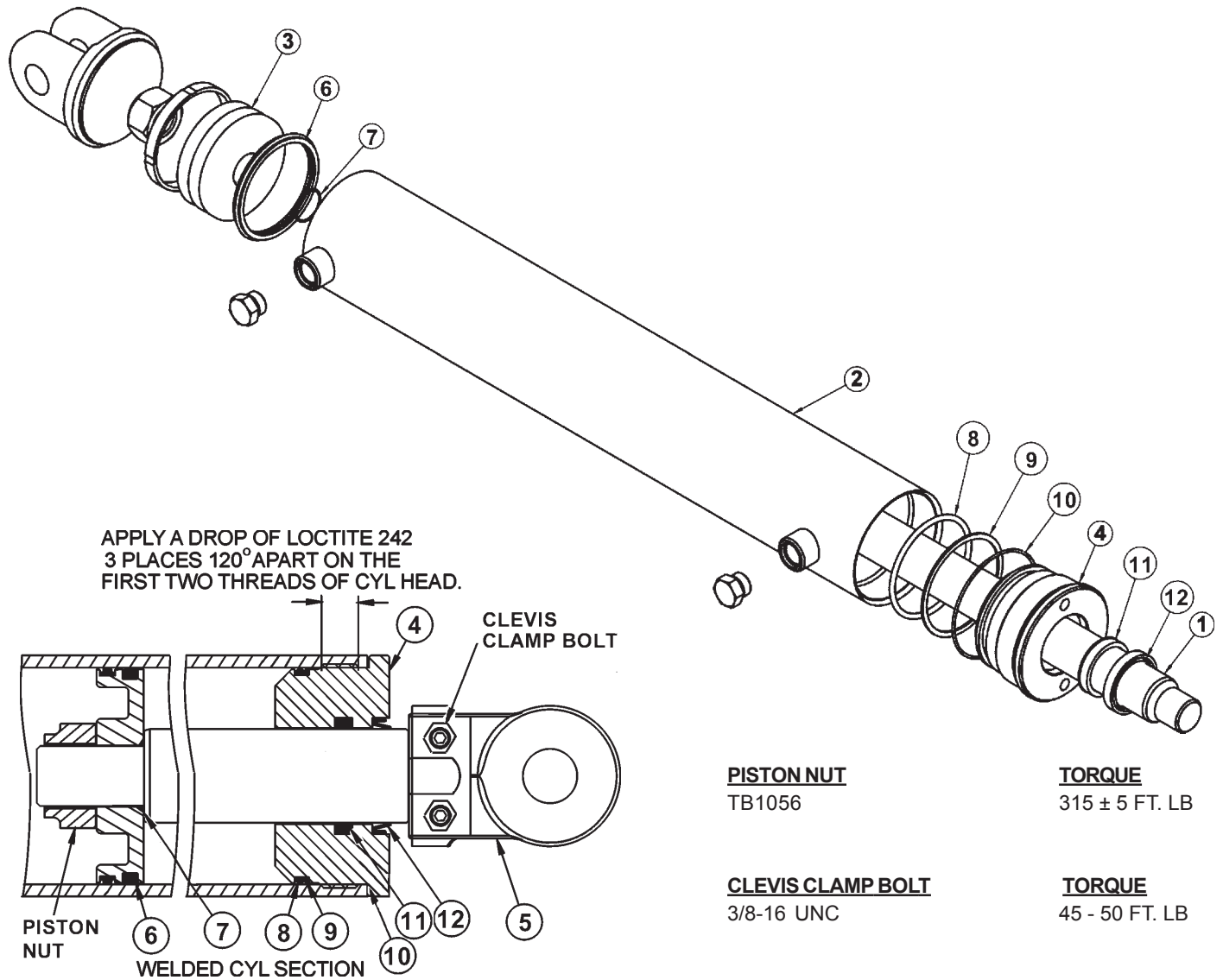

WARNING - MECHANICAL FASTENERS MUST BE TORQUED TO RECOMMENDED SPECIFICATIONS DURING REPAIR TO PREVENT PERSONAL INJURY OR EQUIPMENT DAMAGE.

ITEM	PART NO.	QTY.	DESCRIPTION
*	06501024	AVAIL	HYDRAULIC CYLINDER COMPLETE
1	06501565	1	ROD
2	06501566	1	TUBE WELDMENT
3	06501567	1	PISTON
4	06501568	1	CYLINDER HEAD
5	TB3033	AVAIL	CLEVIS
	06501569	AVAIL	SEAL REPAIR KIT (ITEM 6 THROUGH ITEM 12)

NOTE - ALL SEALS AND WEAR RINGS MUST BE PURCHASED IN COMPLETE SEAL REPAIR KIT.

4" x 9" WELDED CYLINDER PARTS (06501019)

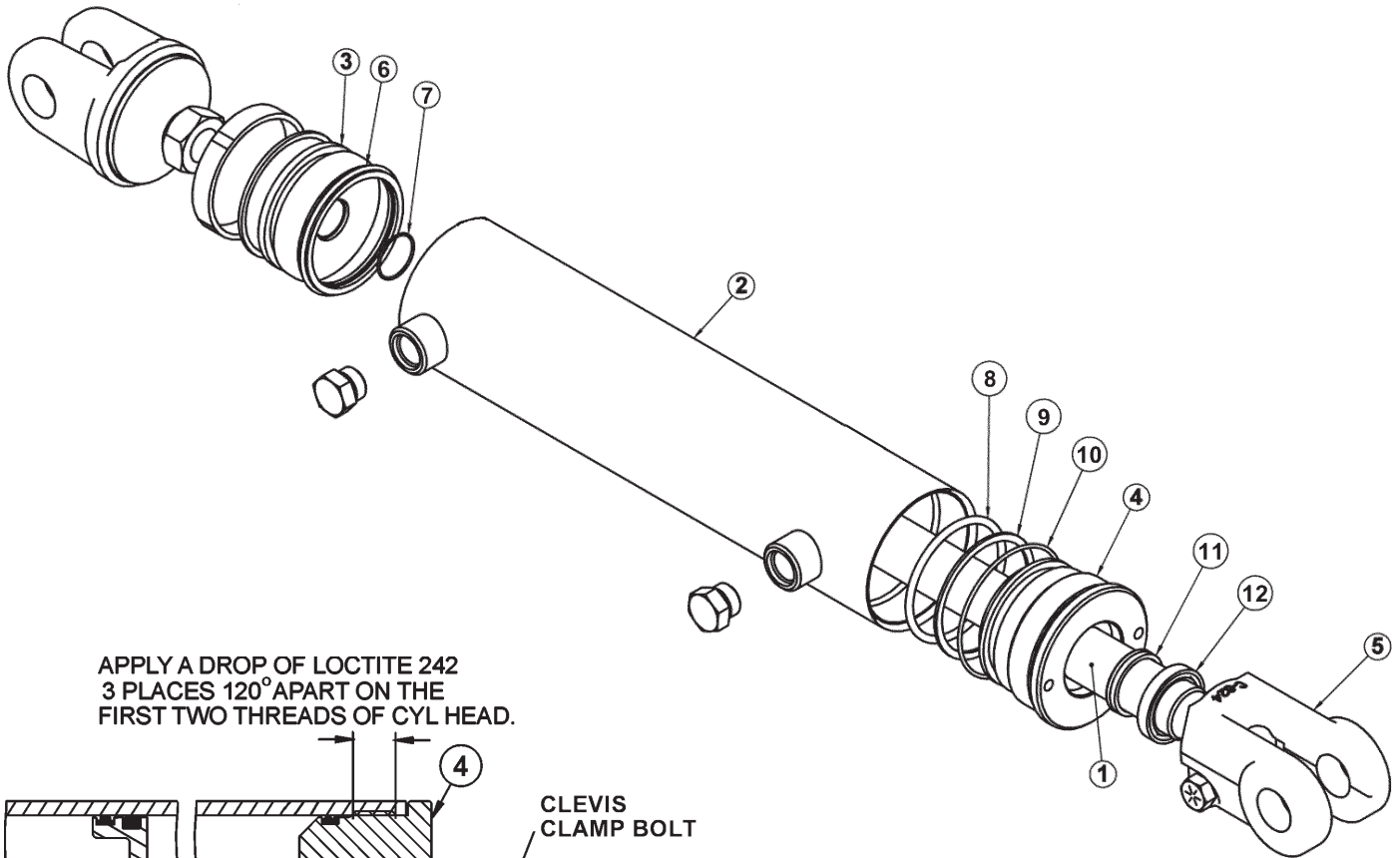

APPLY A DROP OF LOCTITE 242
3 PLACES 120° APART ON THE
FIRST TWO THREADS OF CYL HEAD.

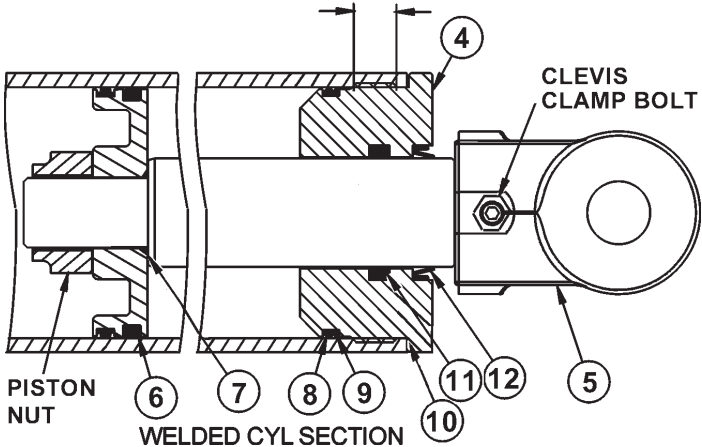

PISTON NUT
06501570

TORQUE
375 ± 5 FT. LB

CLEVIS CLAMP BOLT
3/8-16 UNC

TORQUE
45 - 50 FT. LB

WARNING - MECHANICAL FASTENERS MUST BE TORQUED TO RECOMMENDED SPECIFICATIONS DURING REPAIR TO PREVENT PERSONAL INJURY OR EQUIPMENT DAMAGE.

ITEM	PART NO.	QTY.	DESCRIPTION
*	06501019	AVAIL	HYDRAULIC CYLINDER COMPLETE
1	06501538	1	ROD
2	06501539	1	TUBE WELDMENT
3	06501540	1	PISTON
4	06501541	1	CYLINDER HEAD
5	06501542	1	CLEVIS
	06501543	AVAIL	SEAL REPAIR KIT (ITEM 6 THROUGH ITEM 12)

NOTE - ALL SEALS AND WEAR RINGS MUST BE PURCHASED IN COMPLETE SEAL REPAIR KIT.

4" x 20" WELDED CYLINDER PARTS (06501022)

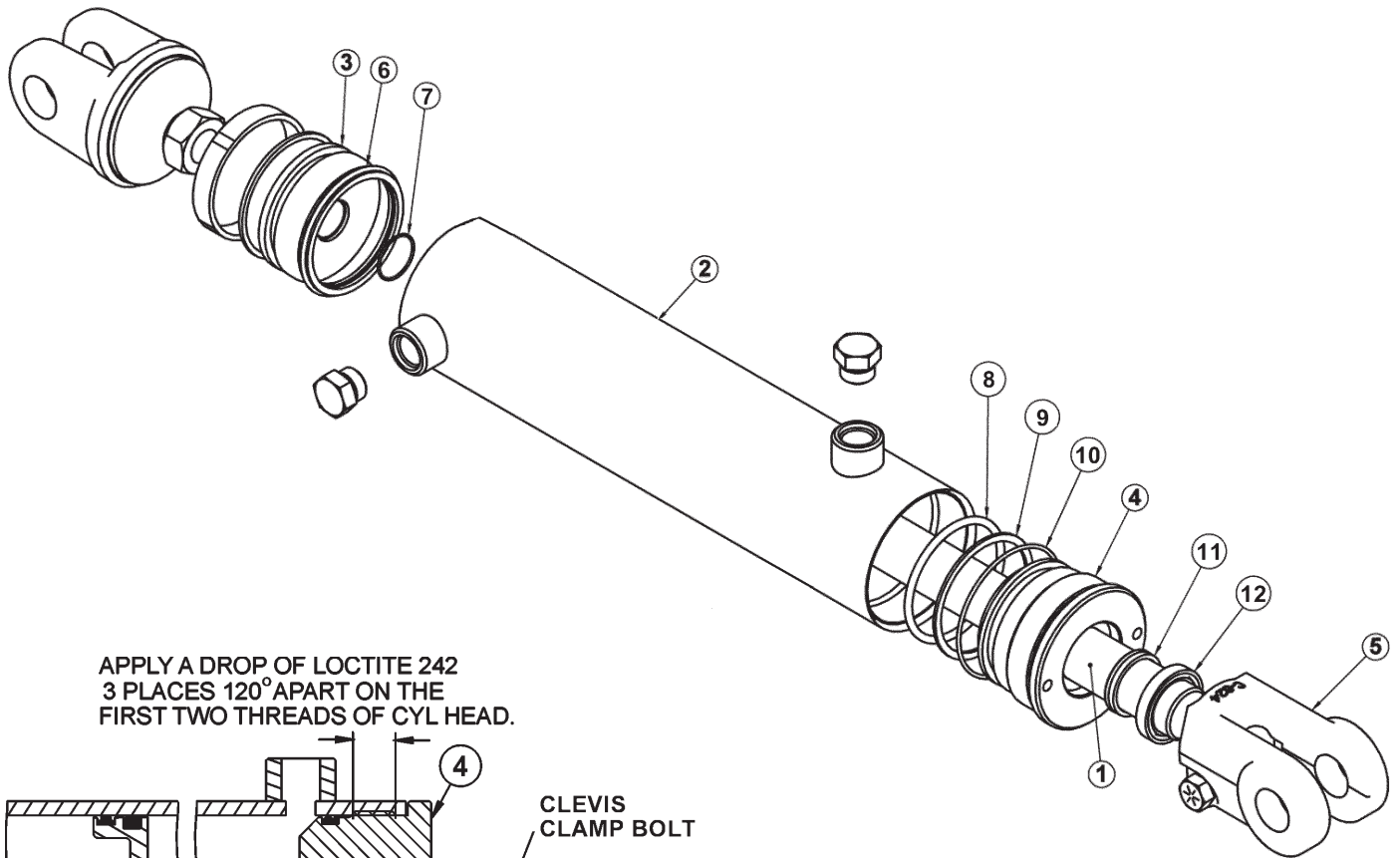

APPLY A DROP OF LOCTITE 242
3 PLACES 120° APART ON THE
FIRST TWO THREADS OF CYL HEAD.

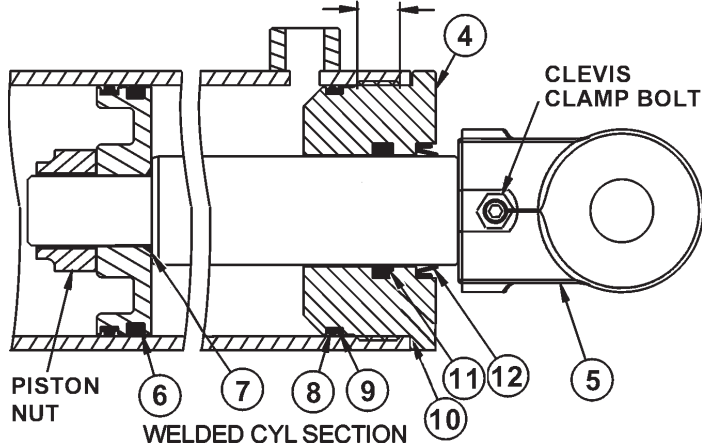

PISTON NUT
06501573

TORQUE
510 ± 5 FT. LB

CLEVIS CLAMP BOLT
3/8-16 UNC

TORQUE
45 - 50 FT. LB

WARNING - MECHANICAL FASTENERS MUST BE TORQUED TO RECOMMENDED SPECIFICATIONS DURING REPAIR TO PREVENT PERSONAL INJURY OR EQUIPMENT DAMAGE.

ITEM	PART NO.	QTY.	DESCRIPTION
*	06501022	AVAIL	HYDRAULIC CYLINDER COMPLETE
1	06501556	1	ROD
2	06501557	1	TUBE WELDMENT
3	06501558	1	PISTON
4	06501559	1	CYLINDER HEAD
5	6T0172	1	CLEVIS
	30172	*	CLEVIS (FOR EXTENDED BOOM)
	06501560	AVAIL	SEAL REPAIR KIT (ITEM 6 THROUGH ITEM 12)

NOTE - ALL SEALS AND WEAR RINGS MUST BE PURCHASED IN COMPLETE SEAL REPAIR KIT.

5" x 20" WELDED CYLINDER PARTS (06501020)

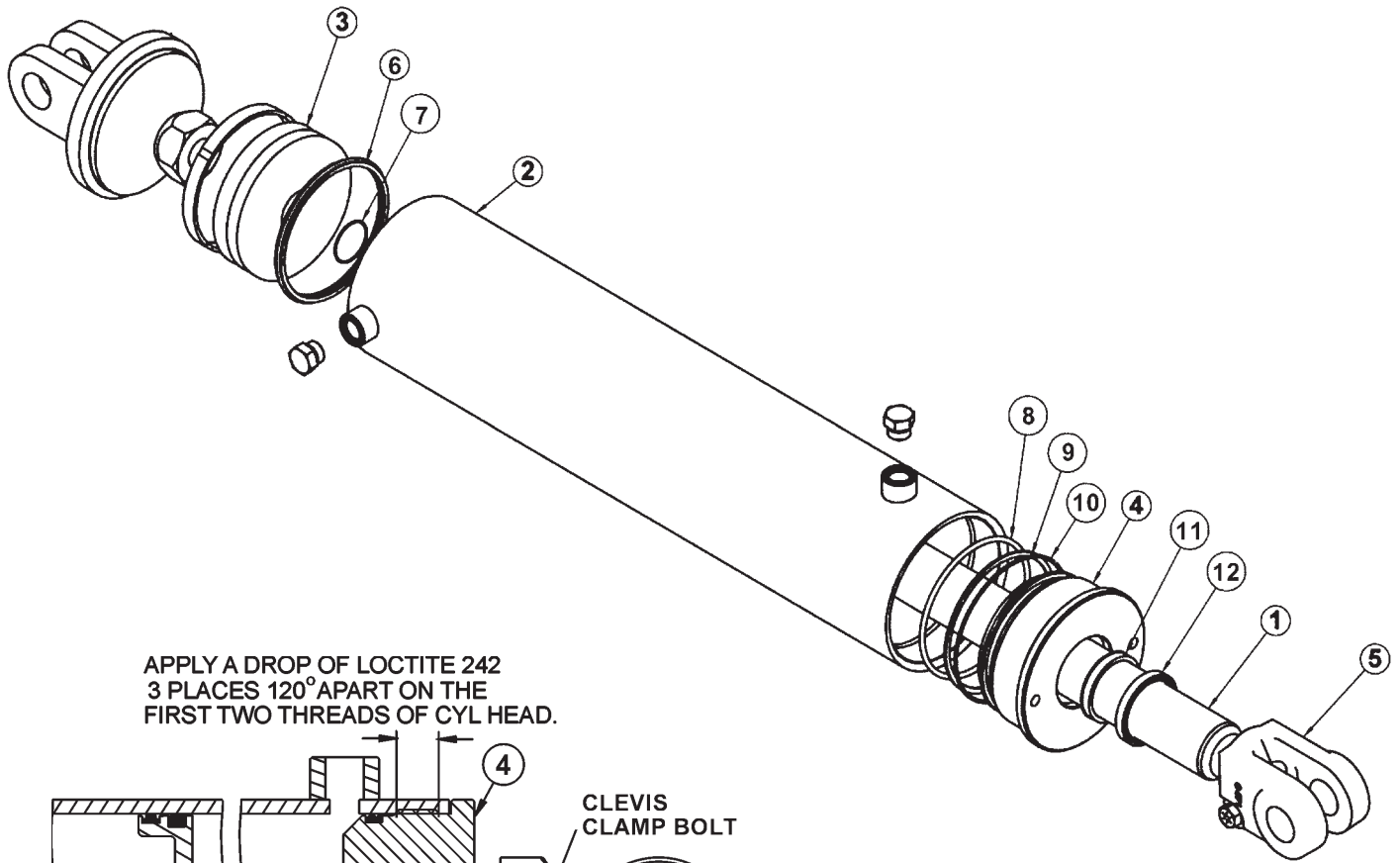

APPLY A DROP OF LOCTITE 242
3 PLACES 120° APART ON THE
FIRST TWO THREADS OF CYL HEAD.

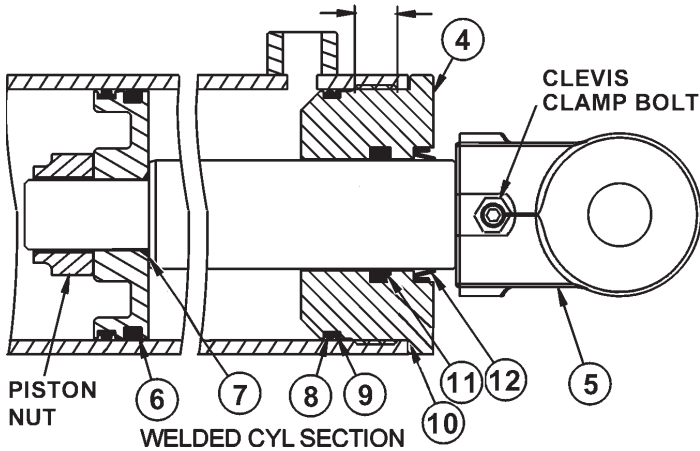

PISTON NUT
06501571

TORQUE
680 ± 5 FT. LB

CLEVIS CLAMP BOLT
3/8-16 UNC

TORQUE
45 - 50 FT. LB

WARNING - MECHANICAL FASTENERS MUST BE TORQUED TO RECOMMENDED SPECIFICATIONS DURING REPAIR TO PREVENT PERSONAL INJURY OR EQUIPMENT DAMAGE.

ITEM	PART NO.	QTY.	DESCRIPTION
*	06501020	AVAIL	HYDRAULIC CYLINDER COMPLETE
1	06501544	1	ROD
2	06501545	1	TUBE WELDMENT
3	06501546	1	PISTON
4	06501547	1	CYLINDER HEAD
5	06501548	1	CLEVIS
	06501549	AVAIL	SEAL REPAIR KIT (ITEM 6 THROUGH ITEM 12)

NOTE - ALL SEALS AND WEAR RINGS MUST BE PURCHASED IN COMPLETE SEAL REPAIR KIT.

ROTARY MOWER SPINDLE ASSEMBLY

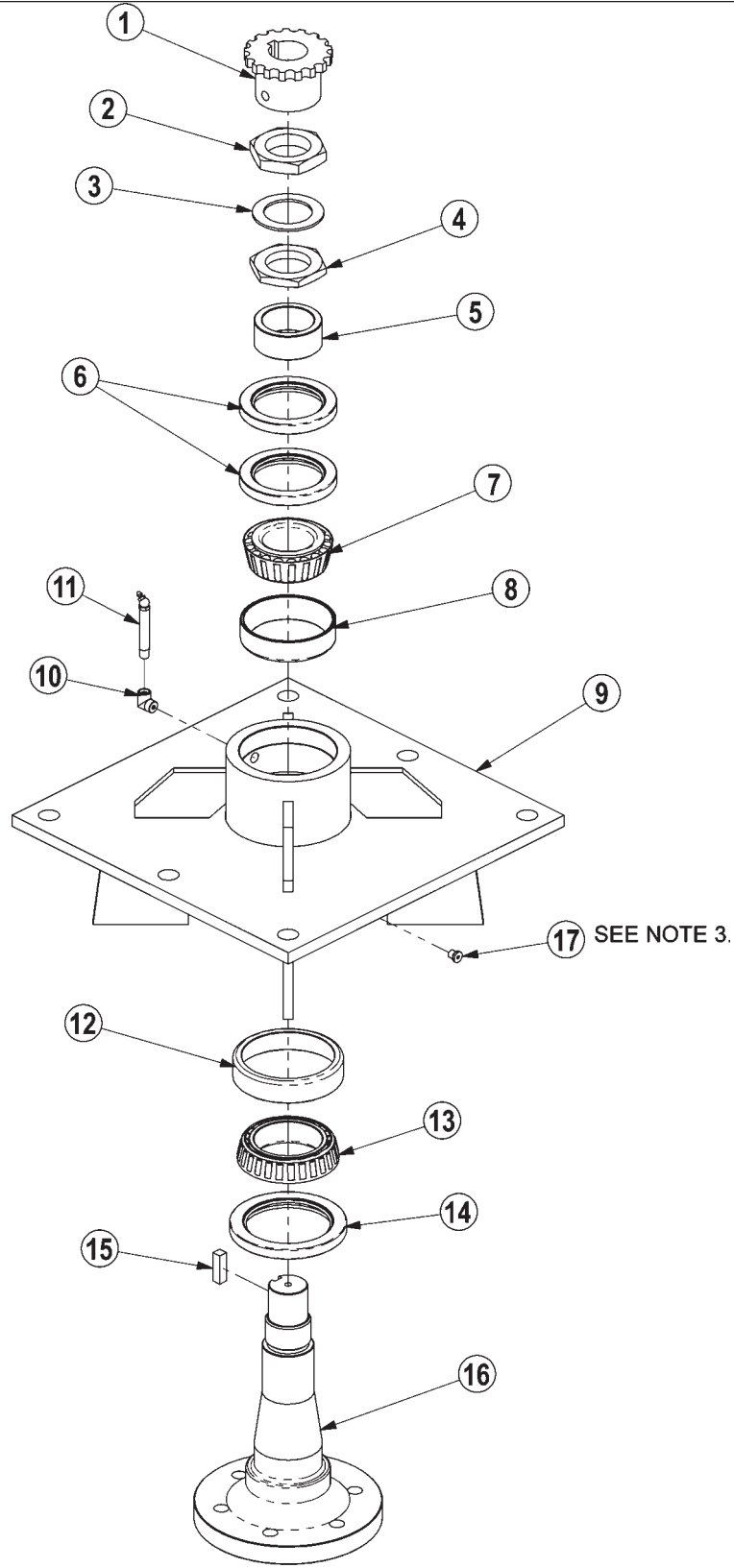

NOTES:

1. FREEPLAY: .001" - .003"
2. GREASE: FILL WITH MOBILITH SHC 220.
3. APPLY LOCTITE "271" TO O-RING PLUG THRDS.

ROTARY MOWER SPINDLE ASSEMBLY

ITEM	PART NO.	QTY.	DESCRIPTION
	6T1024H5	AVAIL	SPINDLE ASSEMBLY COMPLETE
1	6T1031	1	SPROCKET
2	6T1016	1	BEARING LOCK NUT - THICK
3	22596	1	JAM WASHER
4	6T1015	1	BEARING ADJUSTMENT NUT - THIN
5	6T1014	1	BEARING ADJUSTMENT SLEEVE
6	6T1011	1	UPPER SEAL - SET OF 2
7	6T1012	1	BEARING CONE
8	6T1013	1	BEARING CUP
9	6T1010H	1	SPINDLE HOUSING
10	30570	1	FITTING STREET ELBOW
11	33990	1	GREASE ZERK
12	6T1013H	1	BEARING CUP
13	6T1012H	1	BEARING CONE
14	6T1011H	1	LOWER SEAL
15	6T1019	1	SPINDLE KEY
16	PT1018H-5	1	SPINDLE
17	06503064	1	O-RING PLUG, 1/8"
*	31771	AVAIL	SPINDLE REBUILD KIT (INCLUDE ITEMS 2 THRU 8 AND 12 THRU 15)

RESERVOIR TANK FILTER ASSEMBLY

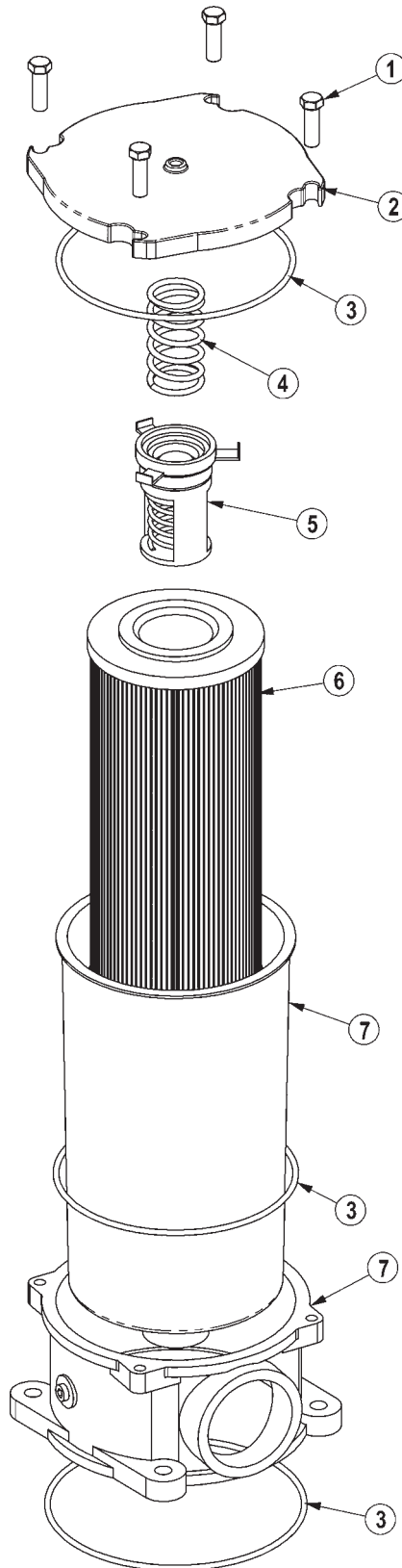

RESERVOIR TANK FILTER ASSEMBLY

ITEM	PART NO.	QTY.	DESCRIPTION
	06505044	AVAIL	FILTER ASSY SAE 10 MICRON
1	28583	4	CAPSCREW,8MMX25MM(1.25 PITCH)
2	06505045	1	COVER
3	06505046	1	SEAL KIT
4	06505047	1	SPRING
5	06505048	1	BYPASS
6	35259	1	FILTER,10 MIC,RETURN LINE
7	06505049	1	CAN/BODY

5 SPOOL ELECTRONIC VALVE - SIDE STOW

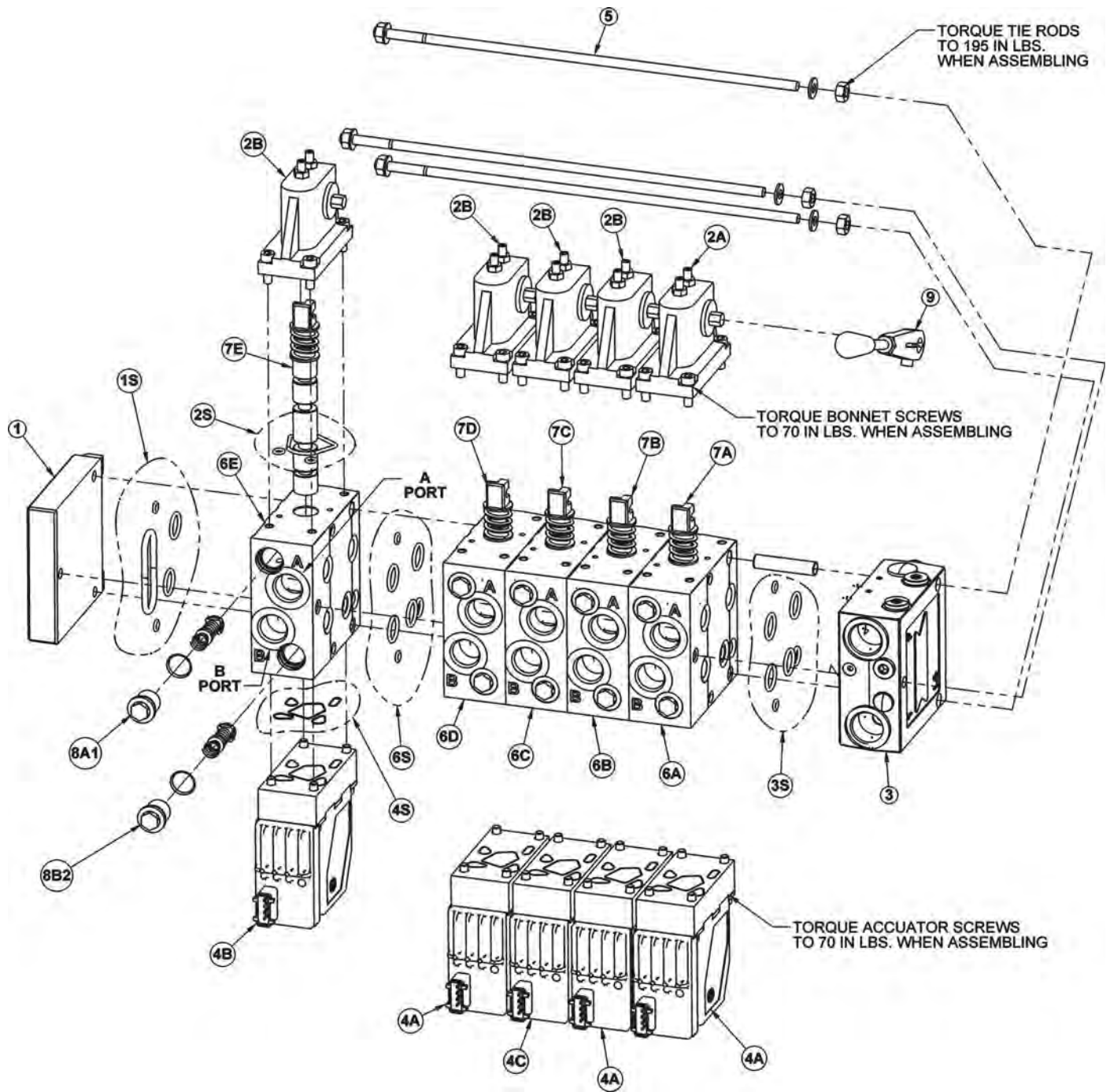

5 SPOOL ELECTRONIC VALVE - SIDE STOW

ITEM	PART NO.	QTY.	DESCRIPTION
AVAIL.	06502096	REF	VLV,5SP,32PVG,SIDE STOW
1	06502074	1	END PLATE
1S	06505013	1	END PLATE SEAL KIT
2	*	5	BONNET
2S	06505042	1	BONNET SEAL KIT
2A	42197	1	MAIN BOOM BONNET
2B	42197	1	SECONDARY BOOM BONNET
2B	42197	1	DECK ROLL BONNET
2B	42197	1	BOOM SWIVEL BONNET
2B	42197	1	DECK SHIELD BONNET
3	34308	1	INLET SECTION
3S	06505013	1	INLET SECTION SEAL KIT
4	*	5	ELECTRONIC ACCUATOR
4A	06502101	1	MAIN BOOM ELECTRONICACCUATOR
4A	06502101	1	SECONDARY BOOM ELECTRONICACCUATOR
4C	06502100	1	DECK ROLL ELECTRONIC ACCUATOR
4A	06502101	1	BOOM SWIVEL ELECTRONIC ACCUATOR
4B	06502099	1	DECK SHIELD ELECTRONICACCUATOR
5	42202	1	TIE-BOLT KIT
6	*	5	SECTION
6S	06505013	1	SECTION SEAL KIT
6A	42698	1	MAIN BOOM SECTION
6B	42698	1	SEC BOOM SECTION
6C	06502076	1	DECK ROLL SECTION
6D	42698	1	BOOM SWIVEL SECTION
6E	06502077	1	SHIELD SECTION
7	*	5	SPOOL
7A	42697	1	MAIN BOOM SPOOL
7B	42697	1	SEC BOOM SPOOL
7C	4242106	1	DECK ROLL SPOOL
7D	06502073	1	BOOM SWIVEL SPOOL
7E	42201	1	DECK SHIELD SPOOL
8	*	10	ANTI CAV/SHOCK RELIEF
8A1	42650	1	MAIN BOOM A PORT RELIEF
8A2	06502069	1	MAIN BOOM B PORT RELIEF
8B1	42650	1	SEC BOOM A PORT RELIEF
8B2	42295	1	SEC BOOM B PORT RELIEF
8C1	42296	1	DECK ROLL A PORT RELIEF
8C2	42295	1	DECK ROLL B PORT RELIEF
8D1	42295	1	BOOM SWIVEL A PORT RELIEF
8D2	42295	1	BOOM SWIVEL B PORT RELIEF
8E1	06502069	1	DECK SHIELD A PORT RELIEF
8E2	06502069	1	DECK SHIELD B PORT RELIEF
9	33459	1	HANDLE

5 SPOOL ELECTRONIC VALVE - OPEN STOW, 3PS

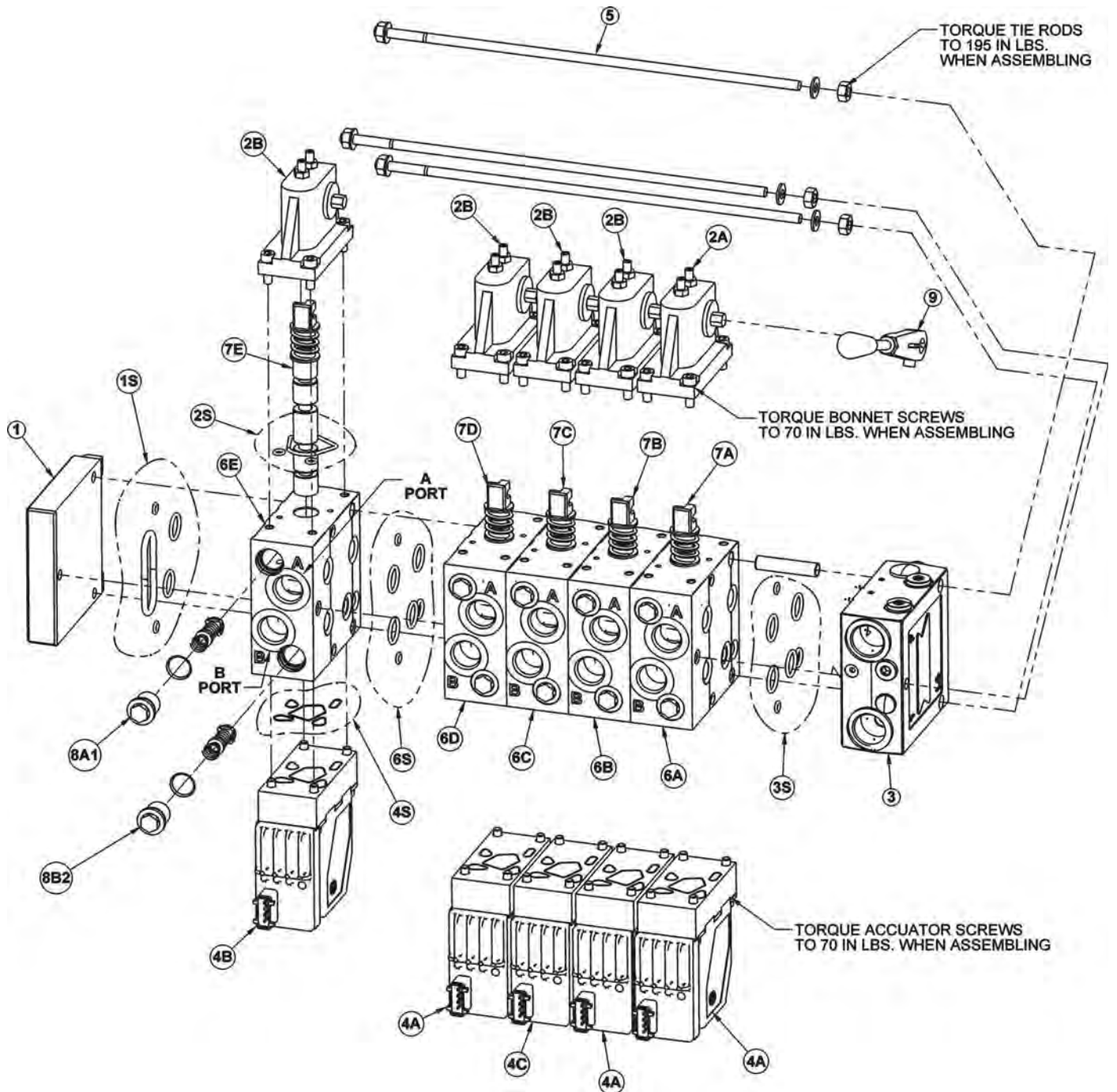

5 SPOOL ELECTRONIC VALVE - OPEN STOW, 3PS

ITEM	PART NO.	QTY.	DESCRIPTION
AVAIL.	06502097	REF	VLV,5SP,32PVG,OPEN STOW, 3OS
1	06502074	1	END PLATE
1S	06505013	1	END PLATE SEAL KIT
2	*	5	BONNET
2S	06505042	1	BONNET SEAL KIT
2A	42197	1	MAIN BOOM BONNET
2B	42197	1	SECONDARY BOOM BONNET
2B	42197	1	DECK ROLL BONNET
2B	42197	1	BOOM SWIVEL BONNET
2B	42197	1	DECK SHIELD BONNET
3	34308	1	INLET SECTION
3S	06505013	1	INLET SECTION SEAL KIT
4	*	5	ELECTRONIC ACCUATOR
4A	06502101	1	MAIN BOOM ELECTRONICACCUATOR
4A	06502101	1	SECONDARY BOOM ELECTRONICACCUATOR
4C	06502100	1	DECK ROLL ELECTRONIC ACCUATOR
4A	06502101	1	BOOM SWIVEL ELECTRONIC ACCUATOR
4B	06502099	1	DECK SHIELD ELECTRONICACCUATOR
5	42202	1	TIE-BOLT KIT
6	*	5	SECTION
6S	06505013	1	SECTION SEAL KIT
6A	42698	1	MAIN BOOM SECTION
6B	42698	1	SEC BOOM SECTION
6C	06502076	1	DECK ROLL SECTION
6D	42698	1	BOOM SWIVEL SECTION
6E	06502077	1	SHIELD SECTION
7	*	5	SPOOL
7A	42697	1	MAIN BOOM SPOOL
7B	42697	1	SEC BOOM SPOOL
7C	4242106	1	DECK ROLL SPOOL
7D	06502073	1	BOOM SWIVEL SPOOL
7E	42201	1	DECK SHIELD SPOOL
8	*	10	ANTI CAV/SHOCK RELIEF
8A1	06502084	1	MAIN BOOM A PORT RELIEF
8A2	06502081	1	MAIN BOOM B PORT RELIEF
8B1	42296	1	SEC BOOM A PORT RELIEF
8B2	06502082	1	SEC BOOM B PORT RELIEF
8C1	42295	1	DECK ROLL A PORT RELIEF
8C2	06502082	1	DECK ROLL B PORT RELIEF
8D1	06502070	1	BOOM SWIVEL A PORT RELIEF
8D2	06502083	1	BOOM SWIVEL B PORT RELIEF
8E1	06502081	1	DECK SHIELD A PORT RELIEF
8E2	06502081	1	DECK SHIELD B PORT RELIEF
9	33459	1	HANDLE

HYDRO PUMP & TSR MOTOR

FRONT PUMP

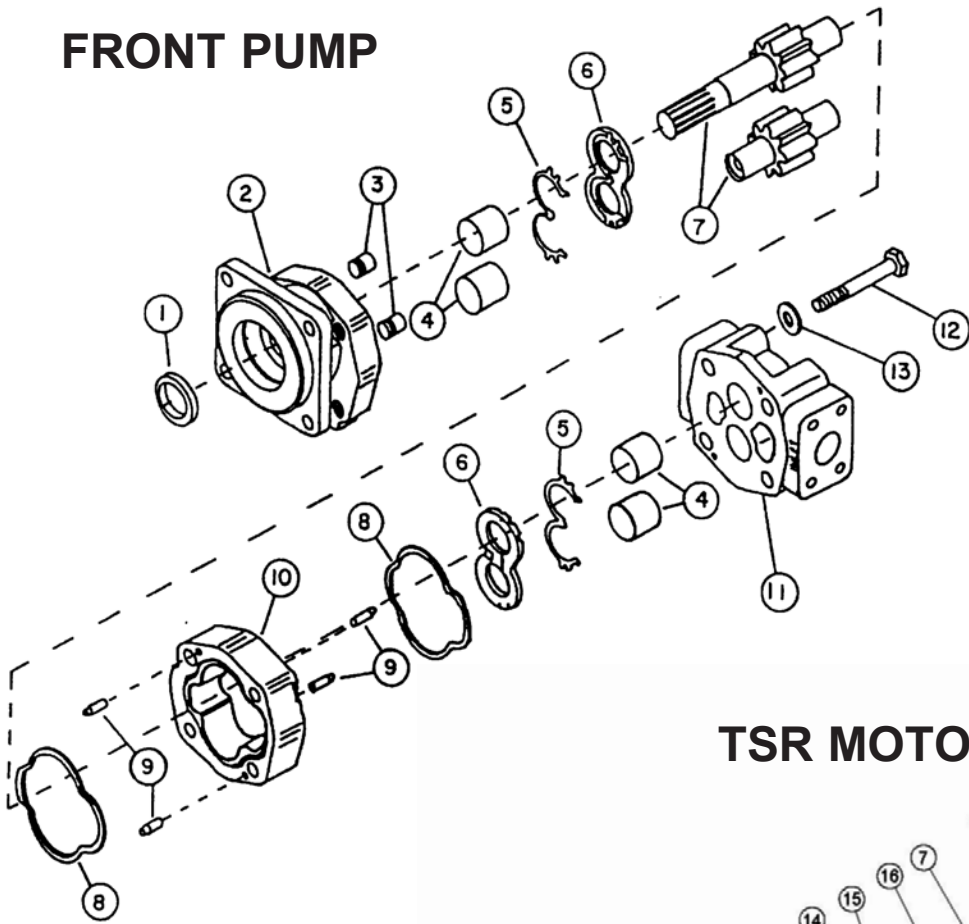

TSR MOTOR

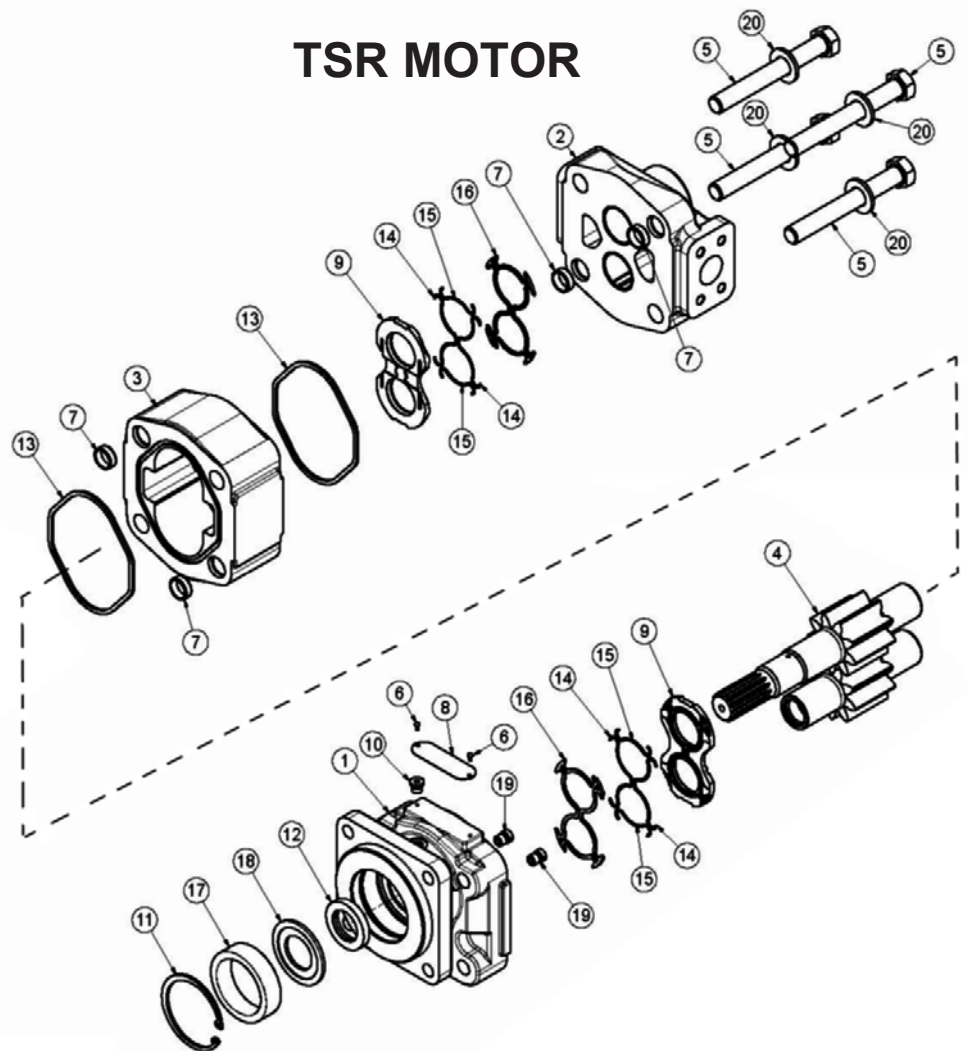

HYDRO PUMP & TSR MOTOR

FRONT HYDRAULIC PUMP

ITEM	PART NO.	QTY.	DESCRIPTION
	23152	AVAIL	PUMP ASSEMBLY 1 3/4" COMPLETE
1	22765	1	SEAL (INCLUDED IN SEAL KIT)
2	22766	1	SHAFT END COVER
3	22767	2	CHECK AND END COVER
4	22768	2	BUSHING
5	22769	2	CHANNEL SEAL (INCLUDED IN SEAL KIT)
6	22770	2	THRUST PLATE (INCLUDED IN SEALKIT)
7	22771	SET	DRIVE SHAFT AND GEAR SET 1 3/4"
8	22772	2	GASKET SEAL (INCLUDED IN SEAL KIT)
9	22773	4	DOWEL PINS
10	22774	1	GEAR HOUSING 1 3/4"
11	22779	1	PORT END COVER
12	23824	4	STUDS
13	22781	SET	WASHER
	6T5322	AVAIL	SEAL APPLICATOR TOOL
	24150	AVAIL	SEAL KIT (INCLUDES 1, 5, 6 AND 8)

TSR MOTOR

ITEM	PART NO.	QTY.	DESCRIPTION
	06504016	AVAIL	MOTOR(M365-1 1/4SPLINE),SEALED
1	22790	1	HOUSING, SEC
2	06504088	1	HOUSING, PEC
3	06504111	1	HOUSING, GEAR
4	06504110	1	SET, GEAR SHAFT
5	06504104	4	CAP SCREW
6	06504078	2	SCREW, DRIVE
7	06504093	4	PIN, DOWEL
8	06504094	1	NAME PLATE
9	06504095	2	THRPL
10	02961940	1	PLUG, ODT (0.25)
11	6T5200	1	RING, SNAP
12	06504097	1	SEAL, LIP
13	22797	2	SEAL, SQ-R
14	06504098	4	SEAL, SIDE CHAN
15	06504099	4	SEAL, END CHAN
16	06504100	2	SEAL, BK-UP
17	06504112	1	SPACER
18	06504113	1	RTNR, SEAL
19	6T5809	2	CHECK ASS'Y
20	06504102	4	WASHER

50" & 60" ROTARY MOTOR

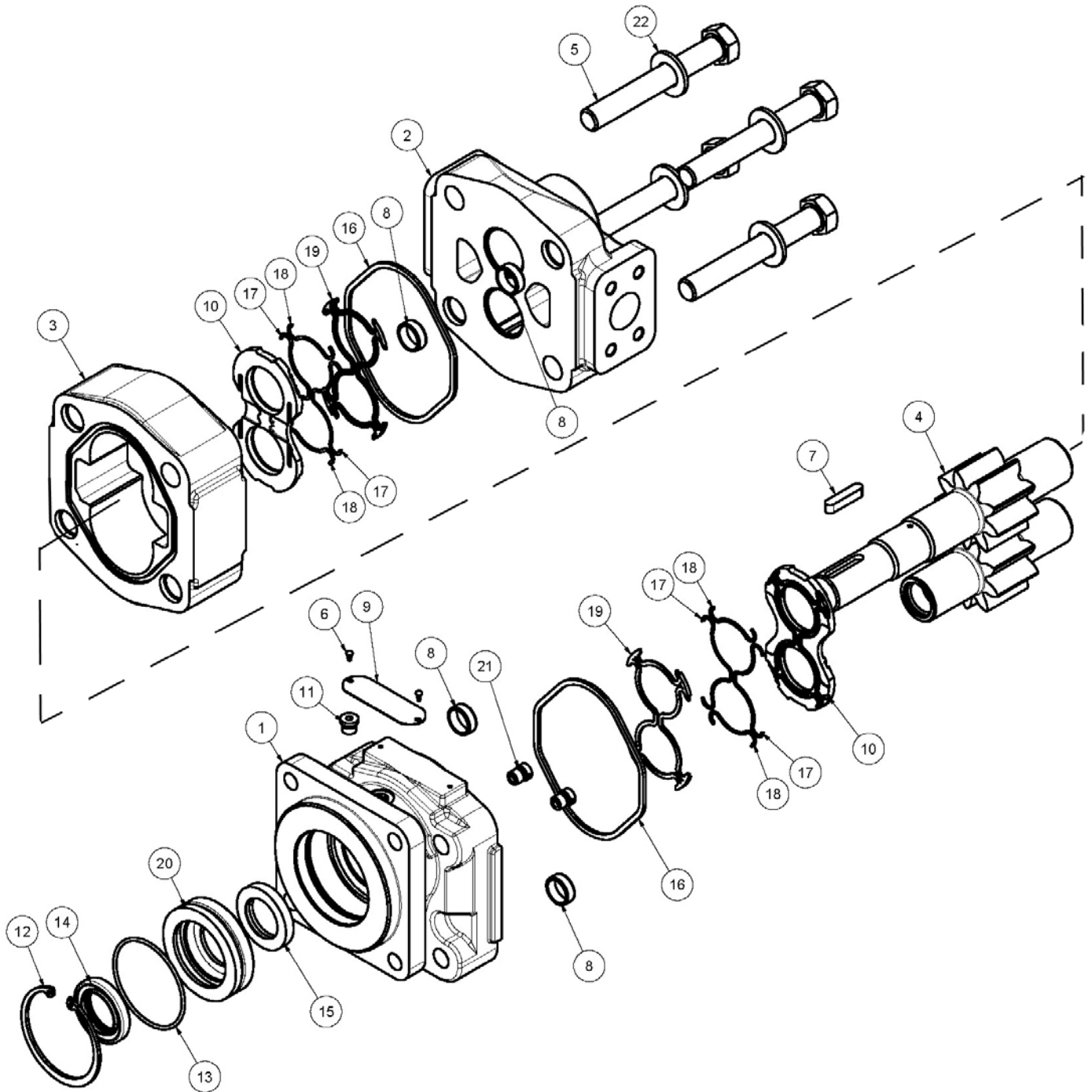

50" & 60" ROTARY MOTOR

ITEM	PART NO.	QTY.	DESCRIPTION
*	06504012	AVAIL	MOTOR ASSEMBLY TRB50
	06504103	1	SEAL KIT
1	22790	1	HOUSING, SEC
2	06504088	1	HOUSING, SEC
3	06504089	1	HOUSING, GEAR
4	06504090	1	SET, GEAR SHAFT
5	06504091	4	CAP SCREW
6	06504078	2	SCREW, DRIVE
7	06504092	1	KEY
8	06504093	4	PIN, DOWEL
9	06504094	1	NAME PLATE
10	06504095	2	THRPL
11	02961940	1	PLUG, ODT
12	02962200	1	RING, SNAP
13	06504096	1	O RING
14	6T5101	1	SEAL, LIP
15	06504097	1	SEAL, LIP
16	22797	2	SEAL, SQ-R
17	06504098	4	SEAL, SIDE CHAN
18	06504099	4	SEAL, END CHAN
19	06504100	2	SEAL, BK-UP
20	06504101	1	RTNR, SEAL
21	6T5809	2	CHECK ASS'Y
22	06504102	4	WASHER
ITEM	PART NO.	QTY.	DESCRIPTION
*	06504011	AVAIL	MOTOR ASSEMBLY 2 1/4" COMPLETE TRB60
	06504103	1	SEAL KIT
1	22790	1	HOUSING, SEC
2	06504088	1	HOUSING, PEC
3	06504062	1	HOUSING, GEAR
4	06504090	1	SET, GEAR SHAFT
5	06504104	4	CAP SCREW
6	06504078	2	SCREW, DRIVE
7	06504092	1	KEY
8	06504093	4	PIN, DOWEL
9	06504094	1	NAME PLATE
10	06504095	2	THRPL
11	02961940	1	PLUG, ODT
12	02962200	1	RING, SNAP
13	06504096	1	O RING
14	6T5101	1	SEAL, LIP
15	06504097	1	SEAL, LIP
16	22797	2	SEAL, SQ-R
17	06504098	4	SEAL, SIDE CHAN
18	06504099	4	SEAL, END CHAN
19	06504100	2	SEAL, BK-UP
20	06504101	1	RTNR, SEAL
21	6T5809	2	CHECK ASS'Y
22	06504102	4	WASHER

FLAIL MOTOR

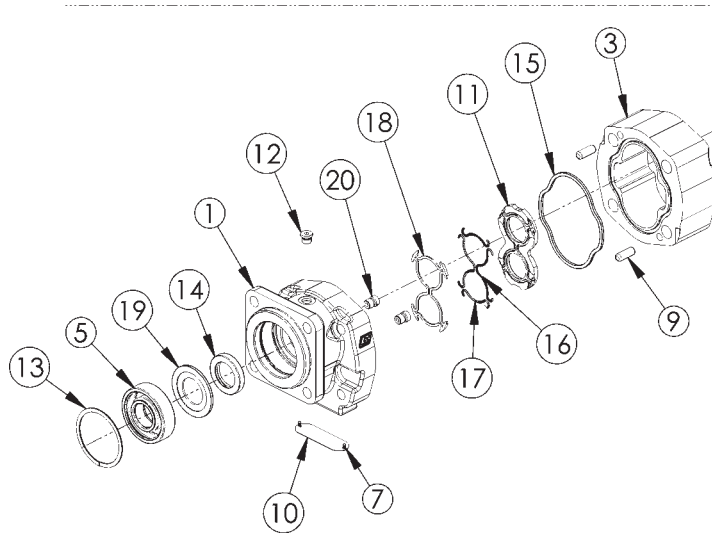
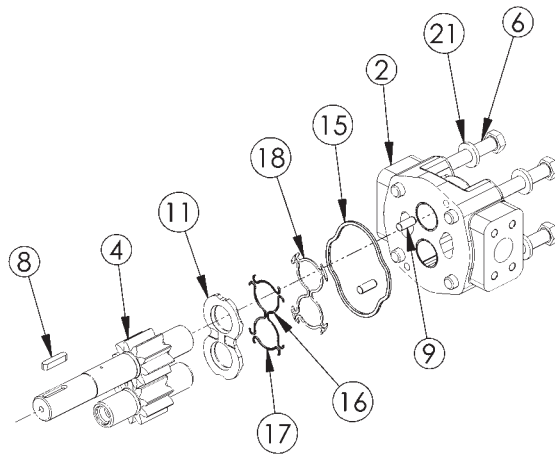

ITEM	PART NO.	QTY.	DESCRIPTION
*	06504013	AVAIL	MOTOR ASSEMBLY 350 - TBF50, TBF63
1	06504039	1	SHAFT END COVER
2	06504040	1	PORT END COVER
3	06504041	1	GEAR HOUSING
4	06504042	1	MATCHED GEAR SET
5	TF4402	1	BALL BEARING
6	06504043	4	CAP SCREW
7	06504044	2	SET SCREW
8	06504028	1	KEY
9	06504045	4	DOWEL PIN
10		1	NAMEPLATE
11	763759	2	THRUSTPLATE
12	02961940	1	HEX PLUG
13	TF4401	1	SNAP RING
14	06504049	1	LIP SEAL (INCLUDED IN SEAL KIT)
15	TF4410	2	GASKET SEAL (INCLUDED IN SEAL KIT)
16	06504046	4	SIDE SEAL (INCLUDED IN SEAL KIT)
17	06504047	4	END SEAL (INCLUDED IN SEAL KIT)
18	TF4407	2	BACK-UP SEAL (INCLUDED IN SEAL KIT)
19	06504048	1	SEAL RETAINER
20	6T5809	2	CHECK ASSEMBLY
21	02961917	4	WASHER
*	06504023	AVAIL	SEAL KIT (INCLUDES 14, 15, 16, 17, AND 18)

PAGE
INTENTIONALLY
LEFT
BLANK

BOOM TRAVEL LOCK

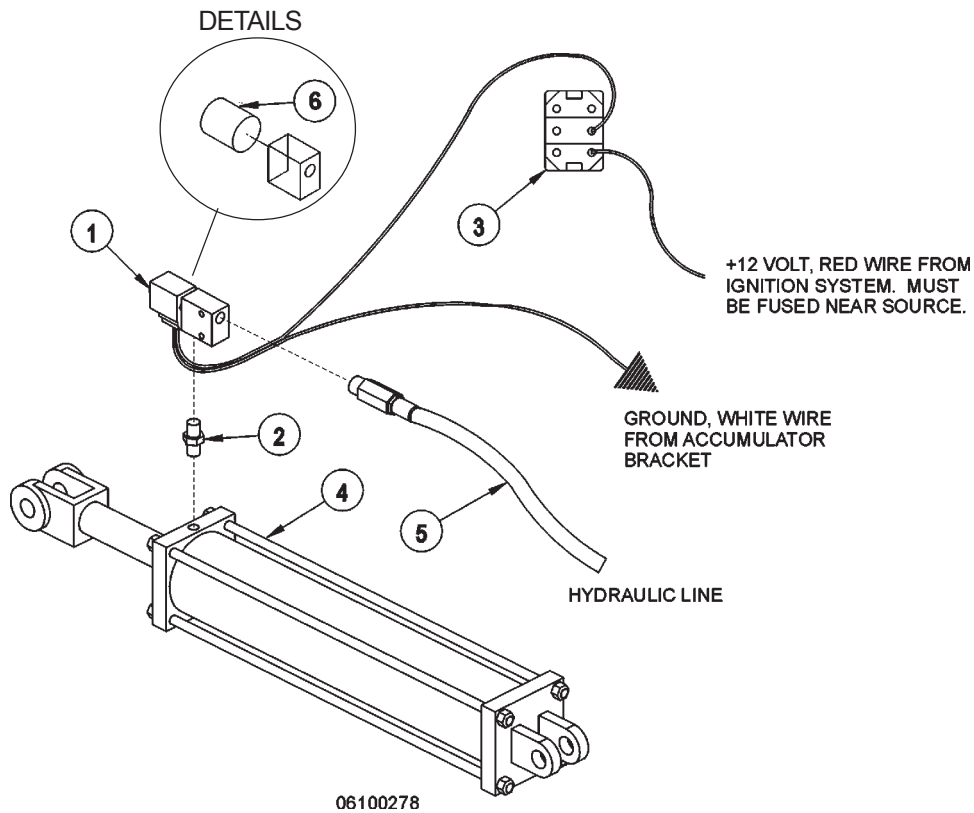

Danfoss Switch Box



Husco Switch Box



OLDER UNITS ONLY, SWITCH ON NEWER MODELS IN SWITCHBOX
Refer to your switchbox before drilling hole or wiring.

For cab units, drill a hole in an open area on the right side of the dash panel and install the toggle switch. For non-cab units, use the mounting bracket included to install the toggle switch on the under side of the valve stand. Install the decal for the toggle switch operation directly by the toggle switch.

ITEM	PART NO.	QTY.	DESCRIPTION
1	31328	1	HYDRAULIC TRAVEL LOCK VALVE
2	31329	1	ADAPTER - STANDARD BOOM
2A	31611	OPT.	ADAPTER - EXTENDED BOOM
3	34532	1	SWITCH, TRAVEL LOCK
4	*	REF.	MAIN BOOM CYLINDER - REFER OTBOOM ASY
5	*	REF.	HOSE / FITTINGS - REFER TO BOOM ASY
6	34796	1	COIL, TRAVEL LOCK

HUSCO CONTROLS SWITCHBOX

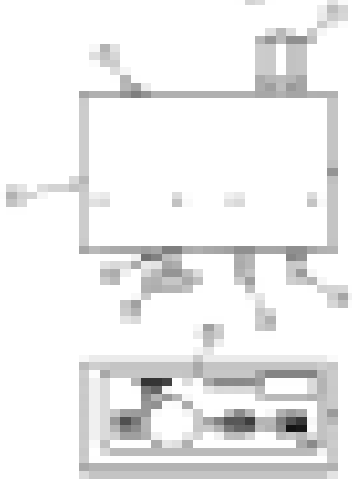
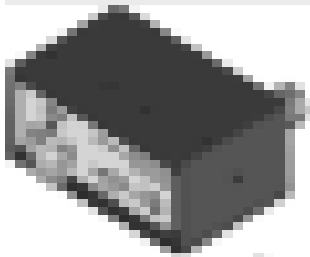
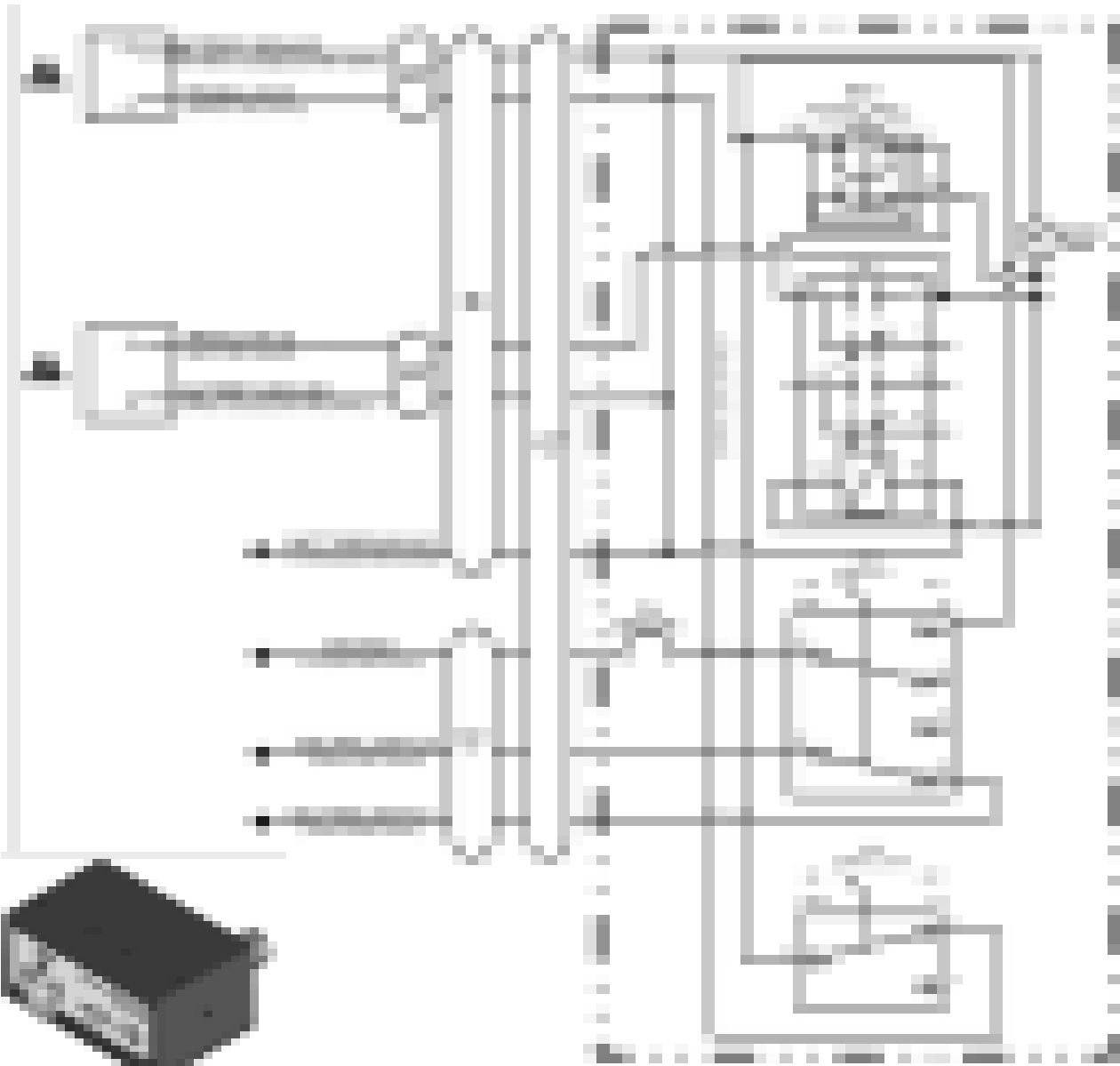

ITEM	P/N	QTY.	DESCRIPTION
1	06514012	1	SWBX,ALUM,BLK,06510100
2	35226	1	SWITCH,MOWER,COLEHERSEE
3	33811	1	SWITCH,MASTER/DECK FLOAT
4	34532	1	SWITCH,TRVL LCK
5	06514014	1	BREAKER,10A,SWBX
6	6T3923	1	INDICTATOR LIGHT,ON,RED
7	34540	1	STRAIN RELIEF,3/4,BLACK,NYLON
8	06550019	1	DECAL,SWTCHBX,BOOM,CG
9	35227	1	RELAY,DP,DT,12V,LY2F,35226

SOLENOID SWITCHBOX AND WIRING

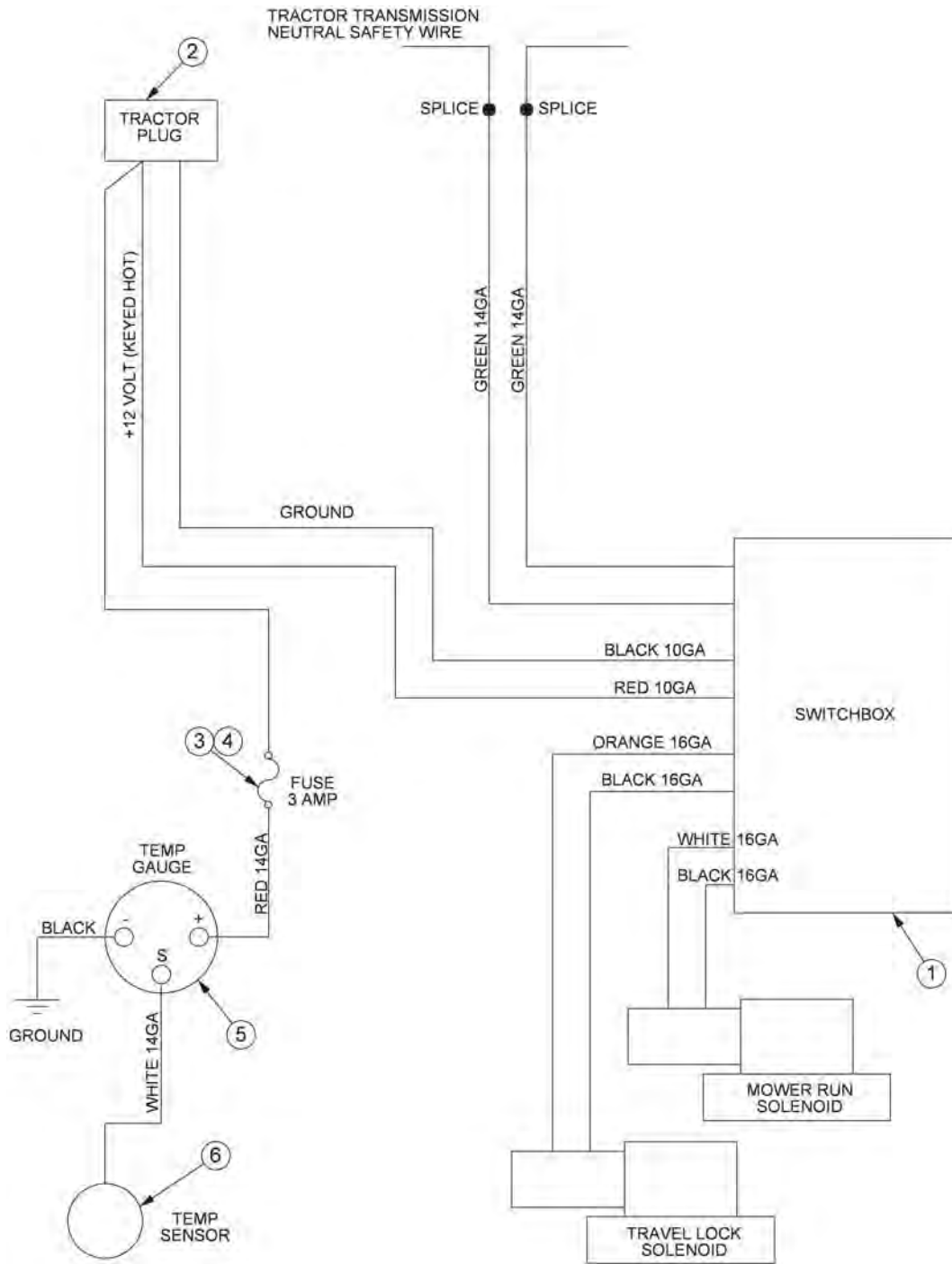

ITEM	PART NO.	QTY.	DESCRIPTION
1	*	REF	SWITCH BOX
2	RE37651	1	PLUG,AUX PWR
3	24204	OPT.	FUSE HOLDER,IN-LINE
4	6T3965	OPT.	FUSE,3AMP
5	6T3934	OPT.	TEMPERATURE GAUGE
6	6T3931	OPT.	TEMPERATURE SENSOR

JOYSTICK SWITCHBOX SERVICE PARTS

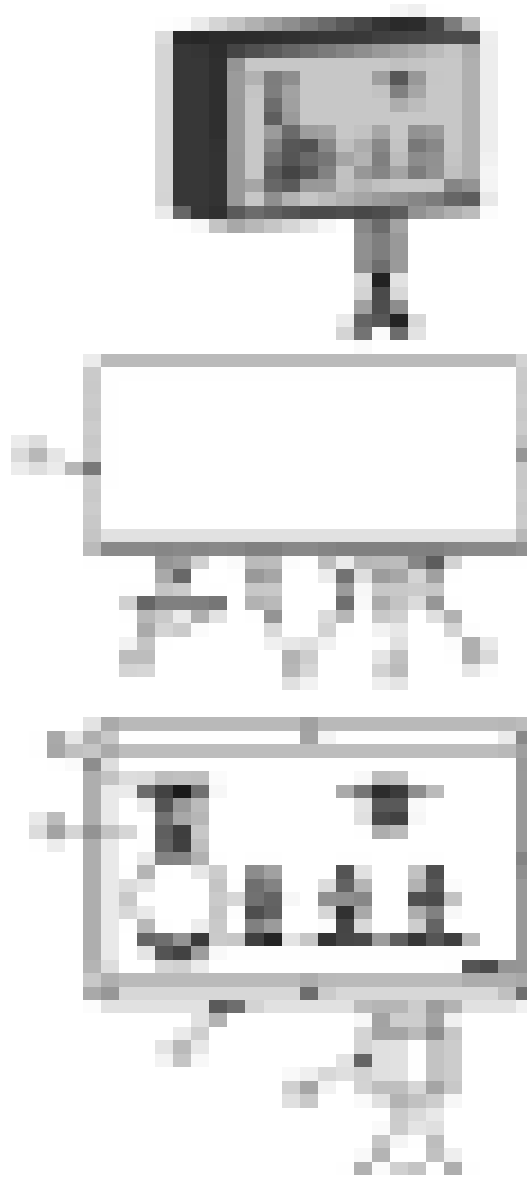

ITEM	P/N	QTY.	DESCRIPTION
1	06510196	1	SWBX,ASSY
2	33811	2	SWITCH,MASTER/DECK FLOAT
3	33813	1	SWITCH,SFTY SHIELD
4	34532	1	SWITCH,TRVL LCK
5	34540	1	STRAIN RELIEF,3/4,BLACK,NYLON
6	6T3923	1	INDICTATOR LIGHT,ON,RED
7	06514006	1	BREAKER,15A,SWBX
8	06550044	1	DECAL,SWBX,06510047
9	35226	1	SWITCH,MOWER,COLEHERSEE
10	35227	1	RELAY,DP,DT,12V,LY2F,35226

JOYSTICK SWITCHBOX SCHEMATIC

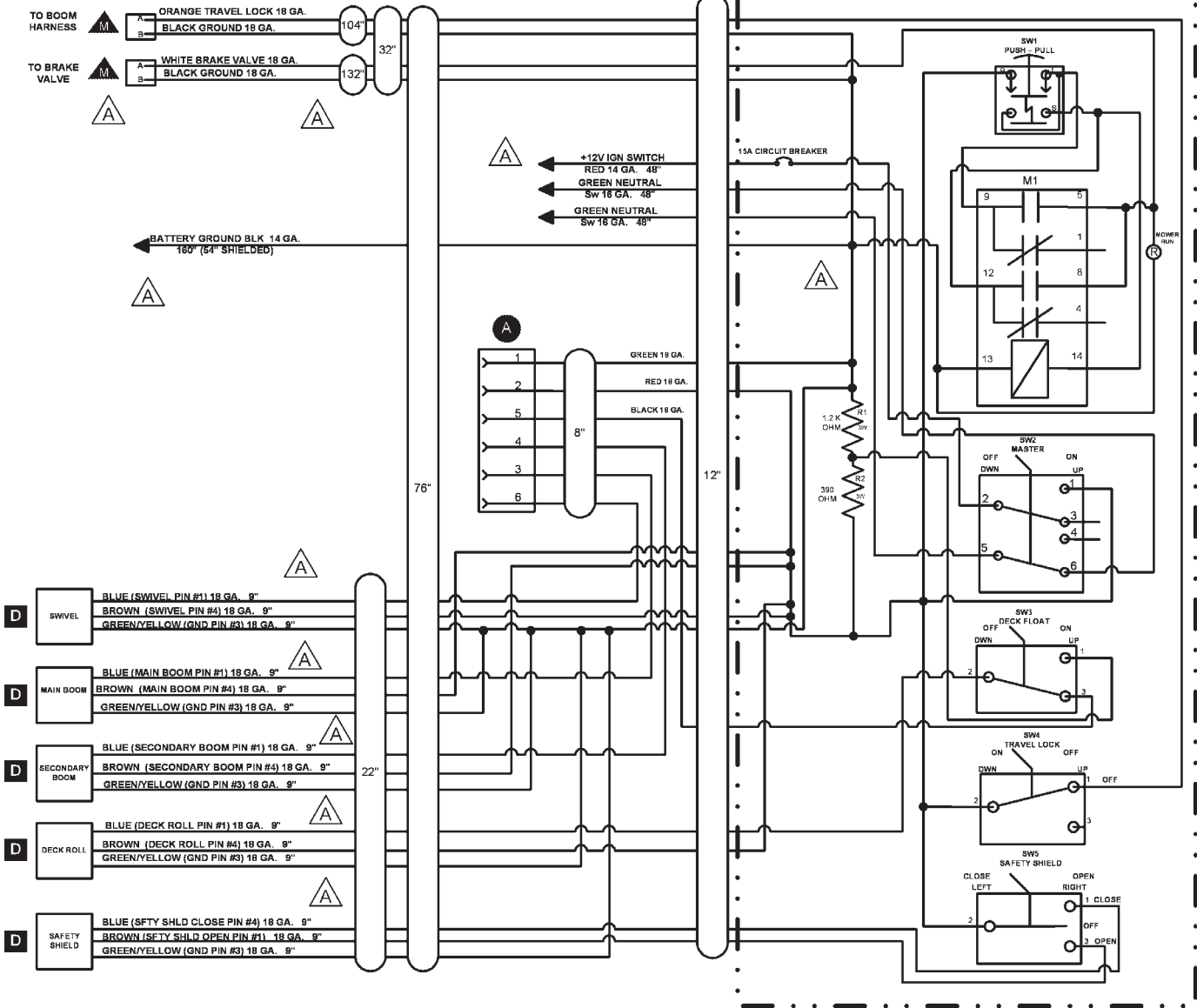

BRAKE VALVE ASSEMBLY W/ METRI PAK

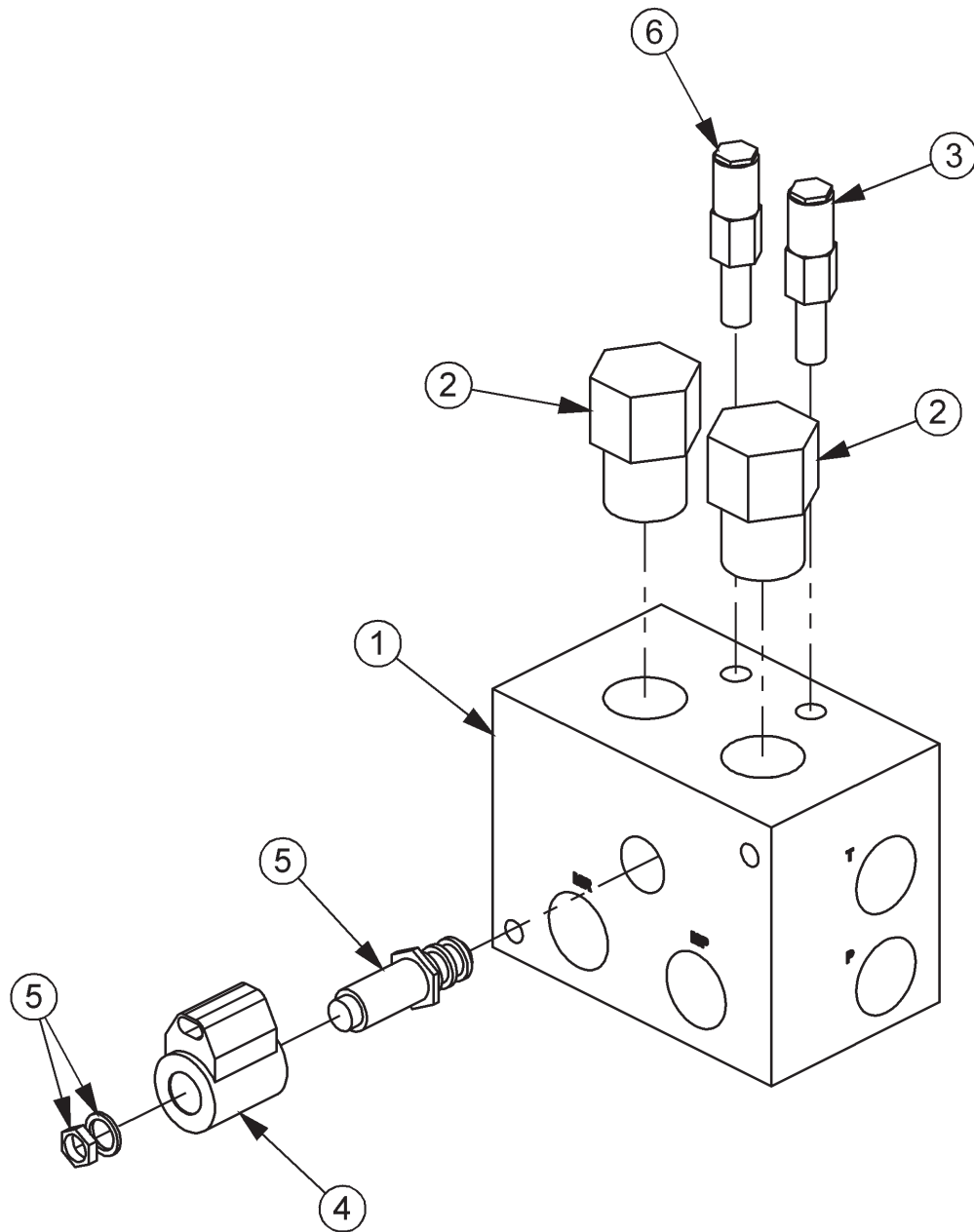

ITEM	PART NO.	QTY.	DESCRIPTION
1	34092	1	BRAKE VALVE, BLANK
2	34094	2	LOGICELEMENT
3	34095	1	RELIEF VALVE, 3500 PSI
4	06510095	1	METRIPAK COIL
5	34093	1	CARTRIDGE, 2 POSITION, 3 WAY (WITH NUT & WASHER)
6	34091	1	RELIEF VALVE, 2600 PSI

BRAKE VALVE HYDRAULIC SCHEMATIC

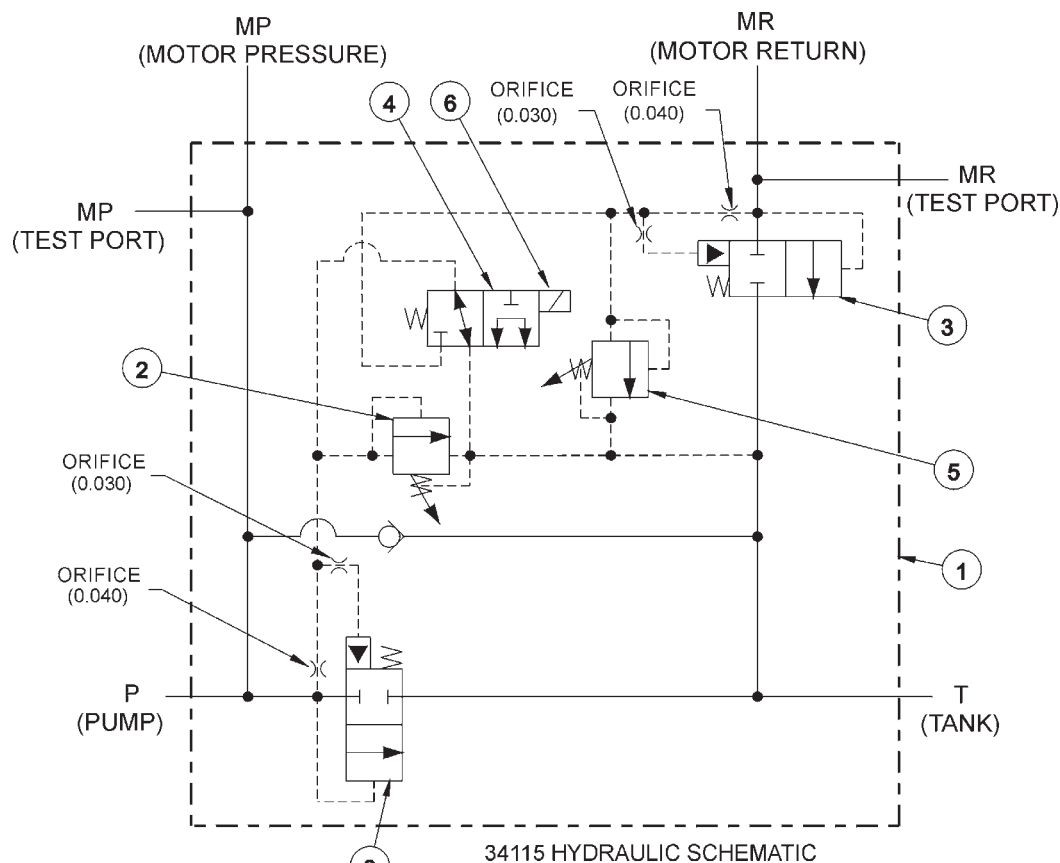

BRAKE VALVE TROUBLESHOOTING

FAILURE MODE:

- MOWER WILL NOT START - system pressure is low (engine not lugging).
- MOWER WILL NOT START - system pressure is high (engine lugging). "MR" port will be high pressure.
- MOWER WILL NOT ROTATE AT FULL SPEED - limited power.
- MOWER BLADE WILL NOT STOP - blade will not stop in proper time.

CHECK STEPS

- 1 thru 6
- 7
- 3 thru 5
- 7 thru 9

CORRECTIVE STEPS:

1. Check for voltage at solenoid (item 6), voltage must be between 10.2 volts and 13.8 volts.
2. Remove, inspect solenoid and cartridge (items 4, 6) for wear or contamination.
3. Remove, inspect logic elements near "P" port (item 3) for wear or contamination.
4. Remove, inspect 3000 psi relief valve (item 2) for wear or contamination.
5. Remove and inspect orifices near "P" port for contamination.
6. Remove "P" port hose and fitting, visually inspect for contamination, check ball for movement.
7. Remove and inspect orifices near "MR" port for contamination.
8. Remove, inspect 2600 psi relief valve (item 5) for wear or contamination.
9. Remove, inspect logic element near "MR" port (item 3) for wear or contamination.

ELECTRICAL - TROUBLESHOOTING GUIDE

Danfoss Electrical Troubleshooting guide

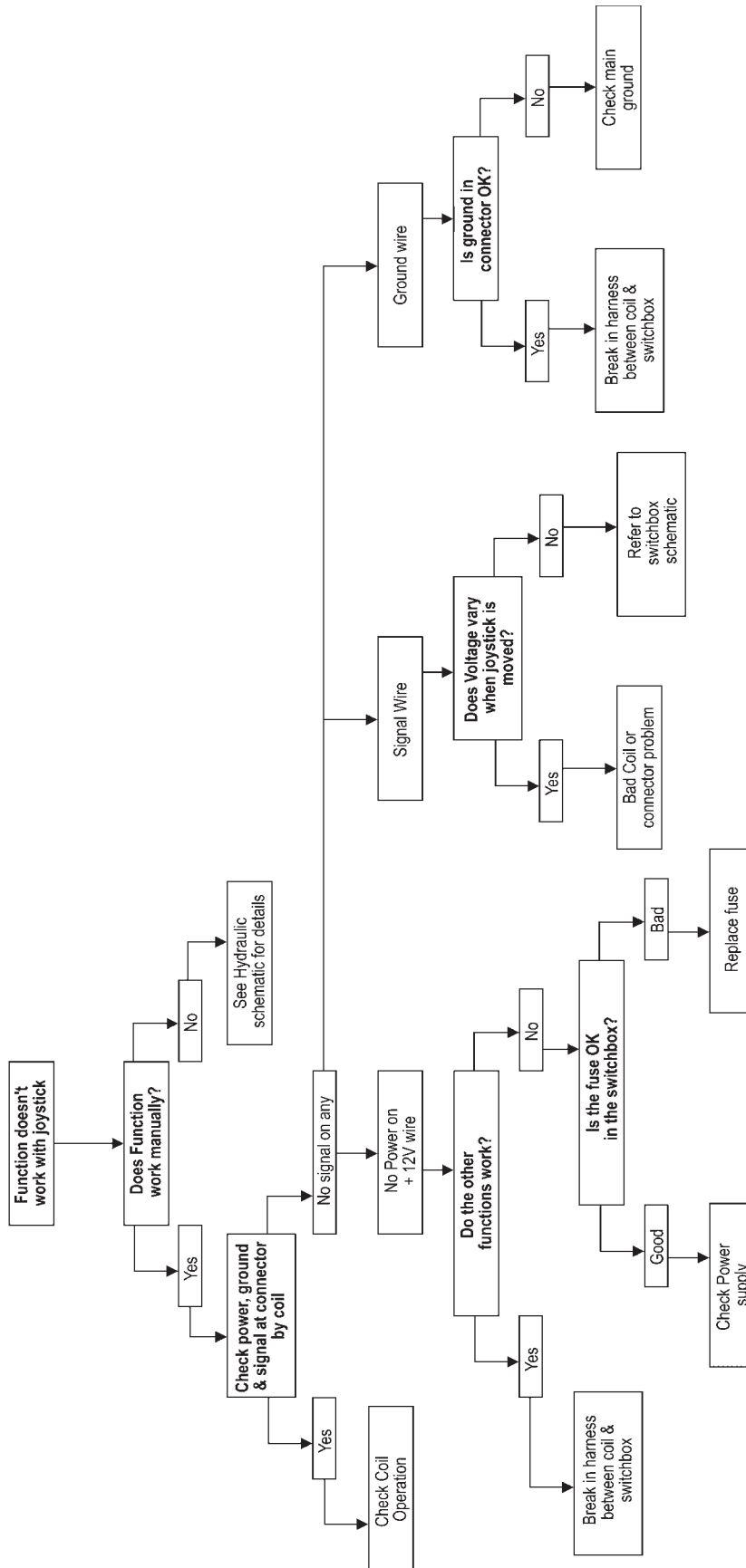

HYDRAULIC - TROUBLESHOOTING GUIDE

Hydraulic Troubleshooting guide

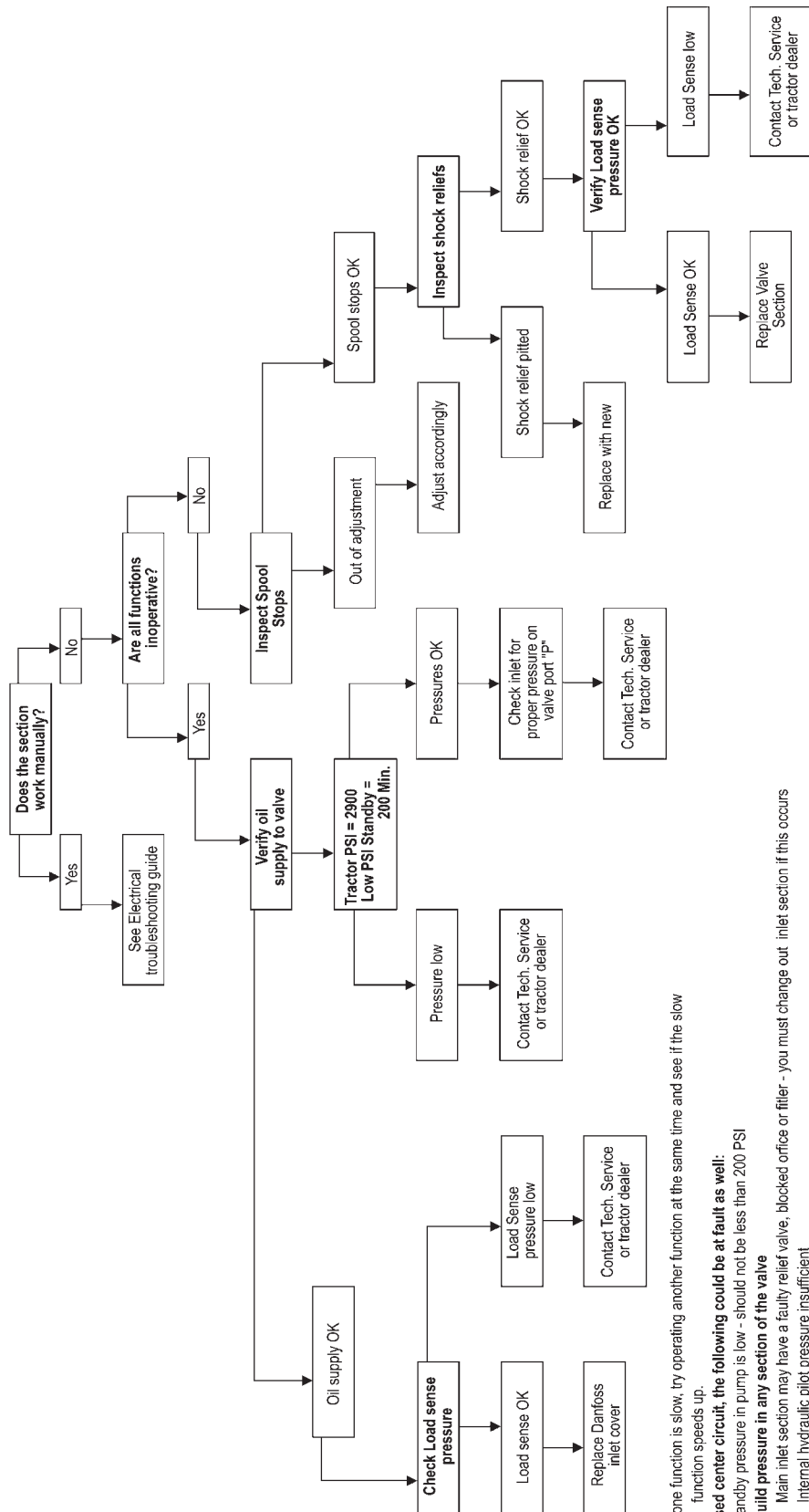

Notes: If one function is slow, try operating another function at the same time and see if the slow function speeds up.

On a closed center circuit, the following could be at fault as well:

Tractor standby pressure in pump is low - should not be less than 200 PSI

Cannot build pressure in any section of the valve

Main inlet section may have a faulty relief valve, blocked orifice or filler - you must change out inlet section if this occurs

Internal hydraulic pilot pressure insufficient

TROUBLESHOOTING

JOYSTICK TROUBLESHOOTING

Boom operation not responding to joystick movement.

Isolate hydraulic vs. electronic symptom.

Turn off electronic master switch (preventing electronic actuator on valve from attempting to hold spool in neutral position). With tractor engine running, operate the valve section with the manual handle. If function operates normally, continue with electronic inspection. If function does not operate normally, continue with hydraulic inspection.

Electronic inspection.

Connect a voltmeter to the cable connector of the valve section that is not operating. This will allow you to measure supply and signal voltage when the joystick is operated.

Main, Secondary, and Swivel Valves – signal voltage should be 50% of supply voltage with joystick in Neutral position, up to 75% of supply voltage in B direction, down to 25% of supply voltage in A direction. Signal voltage should change smoothly with lever movement.

Pin #1 – Supply Voltage Pin #2 – Signal Voltage Pin #gnd – ground

Deck Roll Valve or Float Valve – signal voltage should be 50% of supply voltage with joystick in Neutral position, up to 65% of supply voltage in B direction, down to 35% of supply voltage in A direction. Signal voltage should change smoothly with lever movement. Signal voltage should be approximately 75% of supply voltage when float switch is operated.

Pin #1 – Supply Voltage Pin #2 – Signal Voltage Pin #gnd – ground

Shield Valve or On/Off Valve – Voltage on pin #1 should be equal to supply voltage when switch is operated in A direction. Voltage on pin #2 should be equal to supply voltage when switch is operated in B direction.

Pin #1 – Signal Voltage Pin #2 – Signal Voltage Pin #gnd – ground

If none of the valve will operate with electrical signal, verify that there is oil pressure at the valve inlet. Electrical Valves must have pilot supply oil to move the spools.

Possible electronic problems.

Open circuit (broken wire, bad connection or loose connection in switch box).
Shorted to positive, ground, or other.
Incorrect voltage signal from joystick.

TROUBLESHOOTING

Hydraulic inspection.

Install 3 pressure gauges, on the valve inlet (use M port, or tee into hose supplying oil from the pump to the inlet), on the workport that is not operating, and on the LS port.

With the spools in Neutral

Gear pump – P should be approximately 200 psi, LS = 0, workport – pressure on cylinder or function.

LS pump – P should equal pump standby pressure, LS = 0, workport – pressure on cylinder or function.

Pressure Comp pump – P should equal pump standby pressure, LS = 0, workport – pressure on cylinder or function.

Gear pump – P should be approximately 200 psi higher than LS, LS should equal workport, workport – pressure on cylinder or function.

LS pump – P should be LS + standby, LS should equal workport, workport – pressure on cylinder or function.

Pressure Comp pump – P should equal pump standby pressure, LS should equal workport, workport – pressure on cylinder or function.

Operate one spool, measure pressures with function at end of travel or stop

Gear pump – P should equal valve relief setting or workport shock valve setting. LS should equal workport. Workport should equal relief setting or workport shock valve setting.

LS pump – P should equal valve relief setting, pump max pressure setting, or workport shock valve setting. LS should equal workport. Workport should equal relief setting, pump max pressure setting, or workport shock valve setting.

Pressure Comp pump – P should equal pump standby pressure, LS should equal workport. Workport should equal pump standby pressure or workport shock valve setting.

Operate more than one spool.

Gear pump – P should approximately 200 psi higher than LS. LS should equal highest workport pressure. Workport – pressure on cylinder or function.

LS pump – P should be LS + standby pressure. LS should equal highest workport pressure. Workport – pressure on cylinder or function.

Pressure Comp pump. P should equal pump standby pressure. LS should equal highest workport pressure. Workport – pressure on cylinder or function.

Possible hydraulic problems.

Cylinder leak.

LS signal leaking to tank before reaching pump LS port.

Hydraulic system or pump not supplying flow to valve.

CLEAN CUTTER HEAD

CLEAN CUTTER SECTION

ASSEMBLY - CLEAN CUTTER

CAUTION!



Failure to follow the following warnings and instructions may result in serious injury or damage to the equipment or property!

CAUTION!



WARNING: The blade alone weighs approximately 145 lbs. Be sure its weight can be supported before attempting to replace. The use of a lift mechanism will ease replacement.

CLEAN CUTTER BLADE MOUNTING

The CLEAN CUTTER blade was designed for installation onto a standard TRB50 spindle. It is equipped with replaceable carbide tipped teeth. Carbide is very hard, it will chip or break on impact. Handle the saw blade with care. **DO NOT** roll saw on any hard surface or allow it to strike a hard object. Set it down on a piece of belting or wood to avoid damaging carbide tips. Install two temporary(2) threaded studs into (2) opposite holes in the spindle. Align the bolt holes in adapter (part number 33875) with the studs and slide adapter over studs, be sure to index adapter so as the protruding 2 7/8" diameter pilot on the adapter faces outward away from spindle. Then slide the saw blade (part number 33874) over the studs and onto the 2 7/8" diameter pilot of the adapter. **NOTE:** Orient blade for clockwise rotation (blade rotates clockwise when looking down on top of mower deck). Then slide the collar (part number 33876) over the studs with the chamfered edge of collar to the outside, be sure the counterbore bolt holes face outward. Apply Loctite "271" to the threads of the 5/8-18 x 3" UNF Grade 8 bolts (part number 33877), and install lock washers (part number 21992) onto the bolts, then install bolts through collar, blade, and adapter into the spindle. Remove the threaded studs, and replace with bolts and lockwashers. Torque bolts in an alternating pattern to 184 Ft-lbs.

DANGER!



Never work under the Implement, the framework, or any lifted component unless the Implement is securely supported or blocked up to prevent sudden or inadvertent falling which could cause serious injury or even death. (SG-14)



OPERATION - CLEAN CUTTER

DANGER!



Never operate the Tractor or Implement until you have read and completely understand this Manual, the Tractor Operator's Manual, and each of the Safety Messages found in the Manual or on the Tractor and Implement. Learn how to stop the tractor engine suddenly in an emergency. Never allow inexperienced or untrained personnel to operate the Tractor and Implement without supervision. Make sure the operator has fully read and understood the manuals prior to operation. (SG-4)

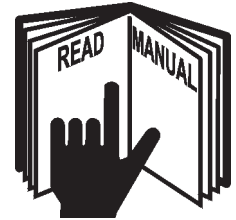

OPERATING INSTRUCTIONS

Inspect clean cutter saw before each use. Re-torque spindle bolts to 204 Ft-lbs. Inspect blade around collar and near the teeth for bends and cracks. Check for loose, broken, chipped, dull or missing teeth. Tighten all loose teeth by hammering and or replacing rivets. If teeth are broken, chipped, or missing or if blade is cracked or becomes bent remove blade and have it repaired at an approved service center. Call Tiger Service Department for replacement parts and service.

The TRB50 Clean Cutter is intended for clean cutting trees and brush up to six (6) inches in diameter maximum. Turn mower "ON" while tractor is running at idle RPM. Then increase tractor speed to 1,950 RPM maximum. Note, this tractor engine speed produces a mower speed of 1,500 RPM. **DO NOT operate the clean cutter mower at speeds in excess of 1,500 RPM.** If saw blade wobbles in excess of two (2) inches while tractor is idling, **STOP**, remove the blade and have it repaired at an approved service center. Call Tiger Service Department for replacement parts and service.

Allow saw to accelerate to maximum speed before moving into foliage. Advance mower head smoothly in foliage. Allow saw to cut through material, do not force or over feed. If saw slows excessively, move the head out of the foliage, and allow the saw to achieve maximum speed. **DO NOT** move up or down or roll mower head while cutting through heavy foliage. **DO NOT** use clean cutter mower on the ground. The saw blade is equipped with carbide tips, which are very hard. Striking rocks, steel, concrete, or other similar debris will break these tips.

Badly worn teeth increase stress to the saw blade and require more horsepower to cut than sharp teeth. Set-up a scheduled maintenance program for the saw before the teeth are dull. The saw will last longer, produce a better cut, cut large diameter foliage without binding, and will cost less to operate.

Check adapter and collar every time saw is changed, maintain the .004 inch taper on face (surface against the saw blade) of these two (2) items. Always clean adapter and collar before mounting the blade. If adapter or collars are worn or damaged, they must be replaced.

Familiarize yourself with the machines operation and correct operating safety precautions.

OPERATION - CLEAN CUTTER

WARNING!



Excessive wobble will generate heat in the blade, rapidly accelerating the loss of tension. The overheated blade will then rub against the foliage as it is cutting, again increasing the heat in the blade and intensifying the wobble. The blade may then weaken, crack and eventually fail. **NEVER RUN A BLADE THAT IS CRACKED OF BENT.**

DANGER!



Always keep a careful lookout and use extreme care when working around overhead obstructions. Never allow the Mower head or boom within 10 feet of any power line. When working close to overhead power lines consult your electric company for a safe code of operation.

(SBM-7)

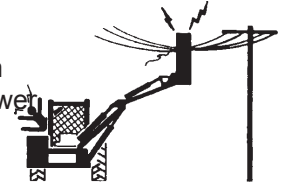

WARNING!



Do not put hands or feet under mower decks. Blade Contact can result serious injury or even death. Stay away until all motion has stopped and the decks are securely blocked up. (SGM-9)



DANGER!



Never operate the Tractor and Mower Unit without an OPS (Operators Protective Structure) or Cab to prevent injury from objects thrown from ground or from overhead trimming. Stop mowing if workers or passersby are with in 100 yards. (SBM-9)

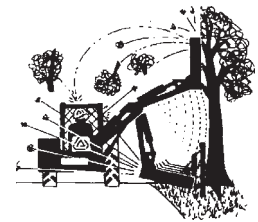

WARNING!



CAUTION: Never leave the key in the ignition switch. Also personal injury or death can occur from sudden dropping or inadvertent operation of the controls. Make cert ain the area is clear before lowering or raising the deck.

MAINTENANCE - CLEAN CUTTER

MAINTENANCE INSTRUCTIONS

Inspect clean cutter saw before each use. Re-torque spindle bolts in an alternating pattern to 204 ft-lbs. Check for loose, broken, chipped, dull or missing teeth. Tighten all loose tooth assemblies by hammer and or replacing rivets. If teeth tips are broken, chipped, or missing, replace tip or replace entire tooth assembly **NEVER RUN SAW BLADE WITH MISSING TOOTH ASSEMBLY**. If saw blade is cracked, becomes bent or wobbles in excess of two (2) inches while the tractor is idling, **STOP**, remove blade and have it repaired at an approved service center. Call Tiger Service Department for replacement parts and service.

These saw blades are pre-tensioned after the tooth assemblies are riveted in place. This pre-tensioning ensures that the blade runs true and remains true under normal cutting load. Removal of more than one or two complete tooth assemblies at a time may effect the tensioning of the blade. Before cutting always check for wobble while machine is running at idle. If blade wobbles in excess of two (2) inches, **STOP**, remove blade and have it repaired at an approved service center. The teeth tips can be replaced without removing the tooth bodies from the saw blade (see TIP REPLACEMENT PROCEDURE). This method is preferred over the entire removal of tooth assemblies.

Check adapter and collar every time saw is changed, maintain the .004 to .006 inch taper (see figure below) on inside face (surface against saw blade) of these two (2) items. Always clean inside face of adapter and collar before mounting the blade. If adapter or collars are worn, chipped, or damaged, they must be replaced.

Any saw blade (regardless of condition) that has seen regular use should be serviced at least once a year at an approved service center

Spare saw blades should be stored in a dry environment and transported only on the wooden crates that are supplied with the saw blade.

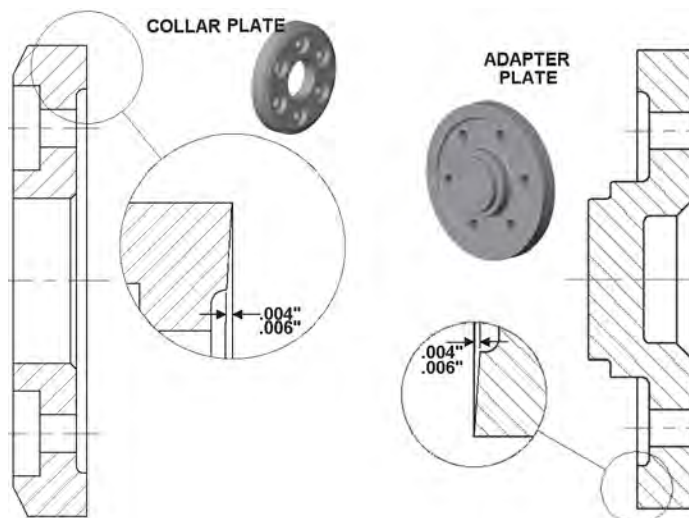

CLEAN CUTTER BLADE AND TEETH PARTS

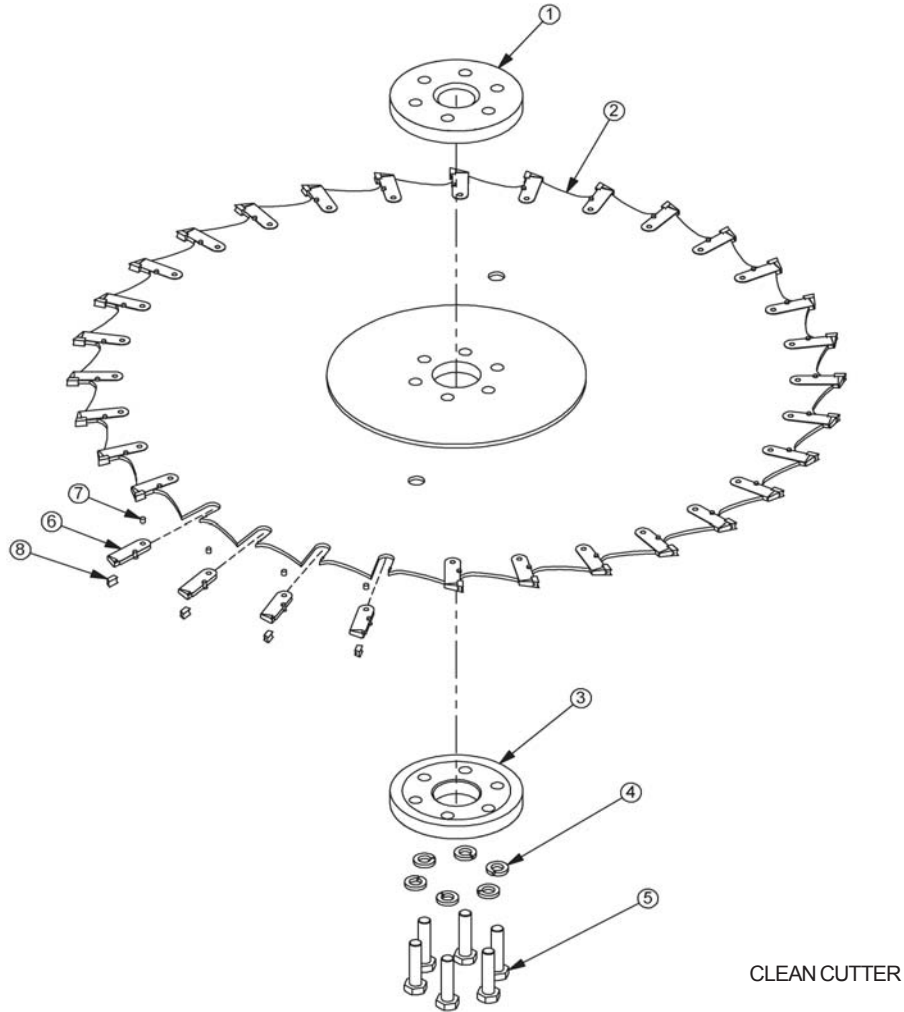

ITEM	PART NO.	QTY.	DESCRIPTION
1	06420024	1	ADAPTER,SAW,TRB50,RNFRCD
2	06520224	1	BLADE, 48" SAW WITH TEETH
3	06420037	1	COLLAR,SAW,TRB50,RNFRCD
4	33764	6	FLATWASHER,5/8,GR 8,SAE
5	06530209	6	CAPSCREW,5/8 x 3 3/4 NF, GR 8
6	06520225	30	TOOTH WITH RIVET, SAW BLADE
7	34703	30	TOOTH RIVET, SAW BLADE
8	34702	30	TOOTH TIP, SAW, CARBIDE
*	34705	AVAIL	SHARPENING TOOL (NOT SHOWN)
*	34704	AVAIL	RIVET REMOVER TOOL (NOT SHOWN)

(UPDATED NOVEMBER '07)

TIP REPLACEMENT PROCEDURE

CARBIDE TIP REPLACEMENT

1. Heat face of tip to **dull orange**, remove tip, then brush tooth body clean of all debris (carbon).
2. Apply acetone to socket rail on tooth body and allow it to evaporate. Dab on soldering paste (black flux) to socket rail of tooth body and slide pre-tinned tip into place.
3. Then heat tip sides and base of socket rail to ensure silver solder flows completely around base of tip. Grasp tip with tweezers and gently twist tip back and forth to ensure complete bonding of silver solder
4. Discontinue heat, and allow to cool. Then check braze by gently tapping tip with rubber mallet.

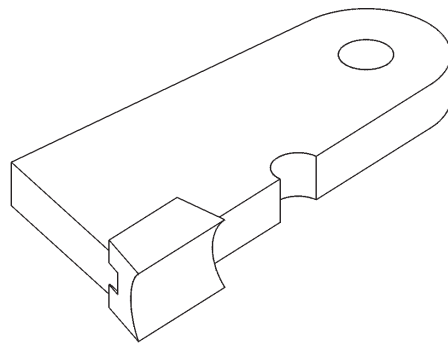

VIEW OF ASSEMBLED TOOTH

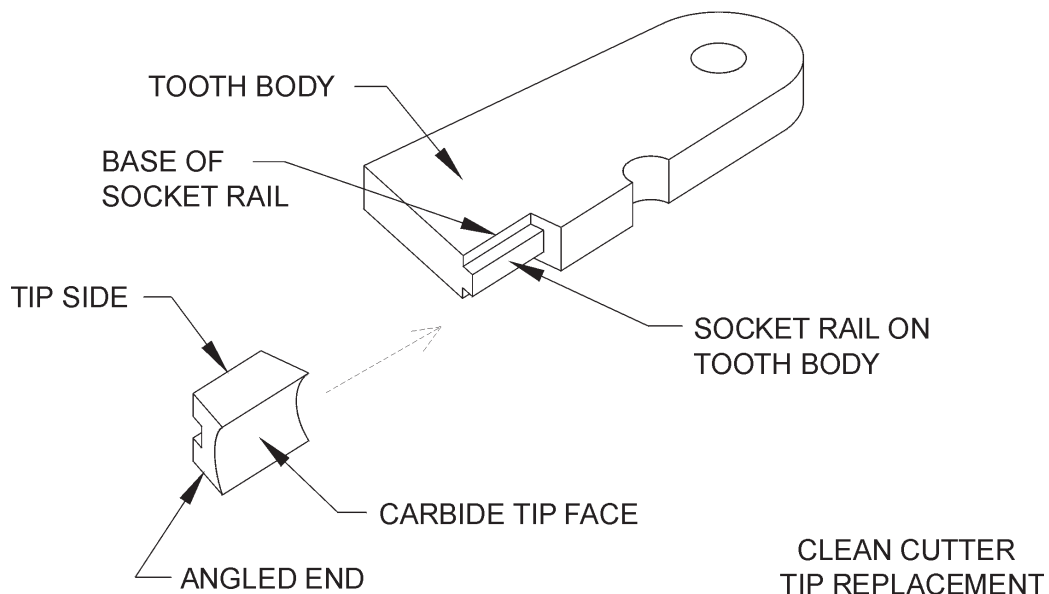

Empty rectangular box at the top of the page.

Large empty rectangular box occupying the majority of the page.

FIRE SUPPRESSION SYSTEM

**FIRE SUPPRESSION SYSTEM
SECTION**

FIRE SUPPRESSION SYSTEM PARTS

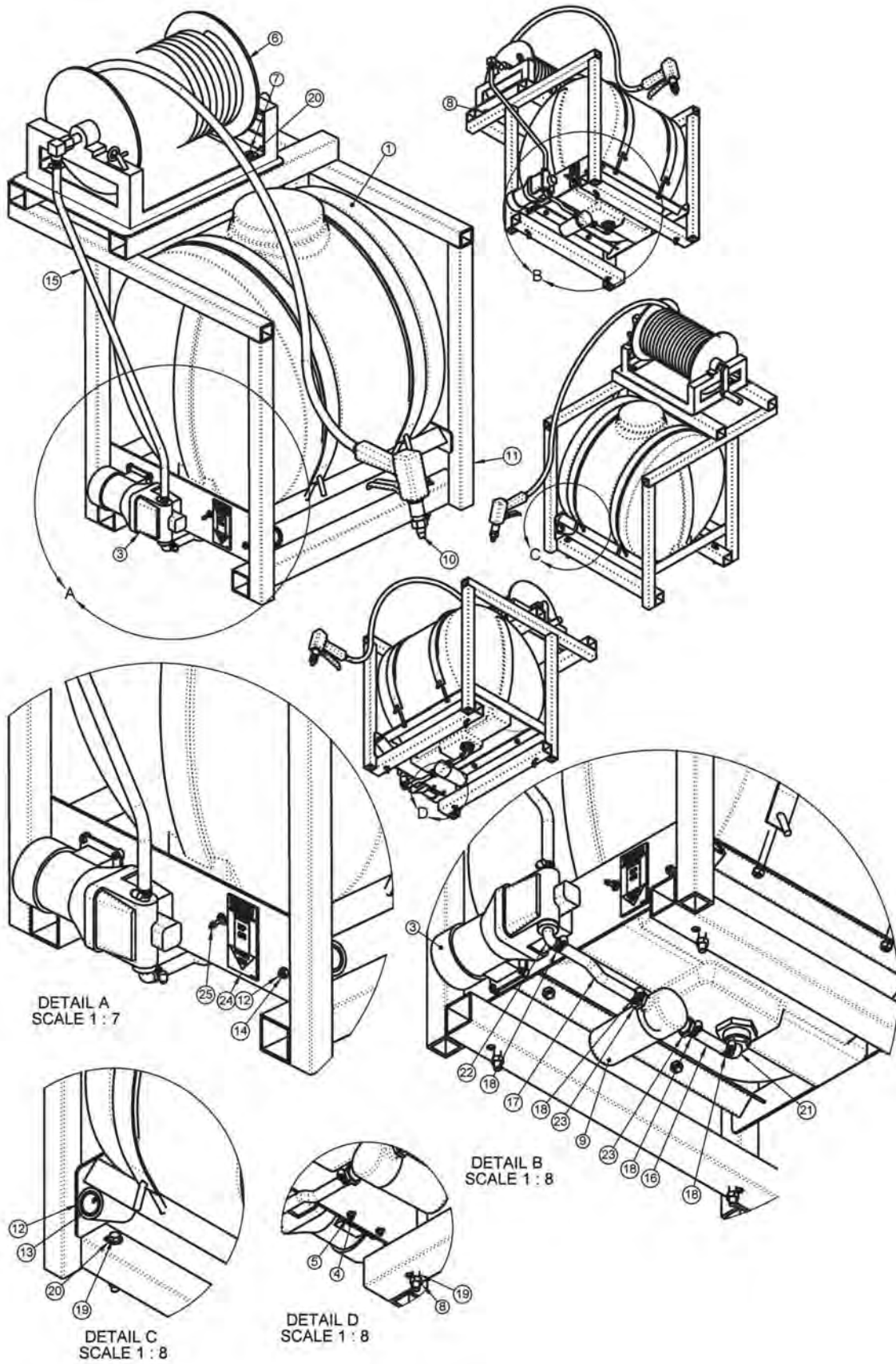

FIRE SUPPRESSION SYSTEM PARTS

ITEM	P/N	QTY	DESCRIPTION
1	06520357	1	TANK,FIRE SUPPRESS SYS,RAILKUT
2	06520358	1	MNT,TANK,FIRE KIT,RAILKUT
3	06520359	1	PUMP,FIRE SUPPRESS SYS,RAILKUT
4	6T2181	4	CAPSCREW,SKT HD,10/24 X 3/4
5	24890	4	HEX NUT,10-24 NYLOCK
6	06520360	1	HOSE REEL,FIRE KIT,RAILKUT
7	21630	4	CAPSCREW, 3/8 x 1,NC
8	21627	8	NYLOCK NUT,3/8",NC
9	06520361	1	FILTER,FIRE KIT,RAILKUT
10	06520366	1	GUN,FIRE KIT,RAILKUT
11	06370120	1	STAND,FIRESYS,RAILKUT
12	06370121	1	HOLSTER,FIRESYS,RAILKUT
13	06430090	1	SLEEVE,GUN,FIRE SYS
14	21525	1	HEX NUT, 1/4" NC
15	06520380 - A	1	HOSE,.880.D.x.50I.D.,BULK
16	06520380 - B	1	HOSE,.880.D.x.50I.D.,BULK
17	06520380 - C	1	HOSE,.880.D.x.50I.D.,BULK
18	35091	6	CLAMP, HOSE #10
19	21640	4	CAPSCREW,3/8" X 3-1/2" NC
20	22016	8	FLATWASHER,3/8"
21	06520367	1	ELBOW,3/4COUPLERx1/2BARB,NYLON
22	06520368	1	ELBOW,3/4COUPLERx1/2BARB,NYLON
23	06503108	2	ADAPTER,BARB,1/2x1/2MP
24	6T3222	1	DECAL,CONTROL,ON-OFF SWITCH
25	PT3905A	1	SWITCH,MOWER
-	06520364	1	FILTER SEAL
-	06520365	1	FILTER ELEMENT

FIRE SUPPRESSION SYSTEM ELECTRICAL SCHEMATIC

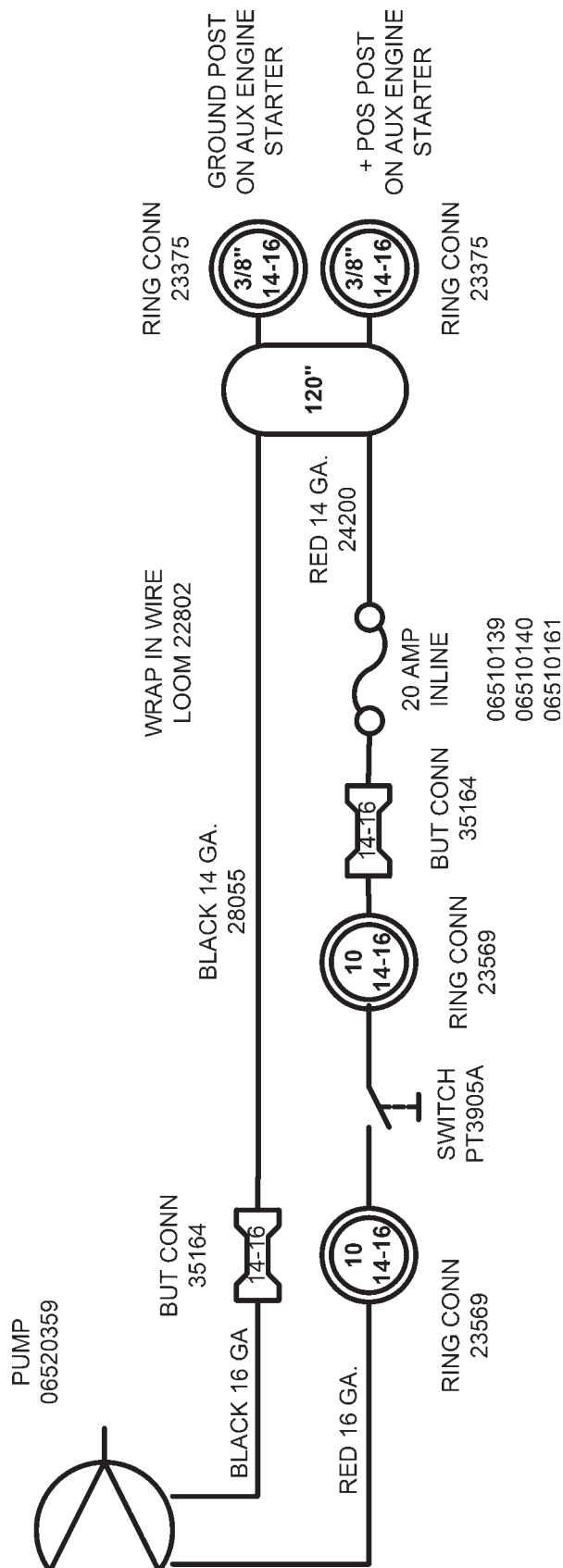

**WARRANTY
SECTION**

WARRANTY INFORMATION

Tiger Corporation, 3301 N. Louise, Sioux Falls, South Dakota, warrants to the original Retail Customer, the new Tiger equipment is free of defects in material and workmanship. Any part of equipment that in Tiger's judgement, show evidence of such defects will be repaired or replaced without charge, provided that the failure of part(s) shall have occurred within twelve (12) months from the date of delivery of said equipment to the Retail Customer. Expendable components such as knives, oil, chain sprockets, skid shoes, knife mounting disks and the like are excluded but not limited to this warranty.

The Retail Customer must pay the transportation cost to and from the Tiger Dealer's service shop for warranty service. Warranty service will be performed by the Tiger Dealer from whom the equipment was purchased, during service shop regularly scheduled days and hours of operation.

All Tiger obligation under this warranty shall be terminated if the equipment is modified or altered in ways not approved in writing by Tiger, if repair parts other than genuine Tiger repair parts have been used, or if the equipment has been subject to misuse, neglect, accident, improper maintenance or improper operation.

Tiger Corporation reserves the right to make improvements in design or changes in specification at any time without incurring any obligation to owners of equipment previously sold.

No agent or person has authority to alter, add to or waive the above warranties which are agreed to be in the only warranties, representations or promises, expressed or implied, as to the quality or performance of the products covered and which do not include any implied warranty of merchantability or fitness. In no event will Tiger be liable for incidental or consequential damages or injuries, including, but not limited to, loss of profits, rental or substitute equipment or other commercial loss.

**THERE ARE NO WARRANTIES WHICH EXTEND
BEYOND THOSE EXPRESSED HEREIN.**

It is the Purchasers obligation to sign the warranty registration form **AFTER** he / she has Read and Understands the Operation and Safety Instructions stated within this manual.

ONE LAST WORD

This manual cannot possibly cover all of the potentially hazardous situations you will encounter. By being familiar with the safety rules, operating and maintenance instructions in this manual you can help prevent accidents. The objective of this manual is to help make you a better operator. Remember, **SAFETY IS YOU!**



1012

Your safety and the safety of those around you depends on **YOU**. Common sense should play a large role in the operation of this machine.

Since we at Tiger Corporation are constantly striving to improve our products, we reserve the right to change specifications or design at any time.

TO THE OWNER / OPERATOR / DEALER



To keep your implement running efficiently and safely, read your manual thoroughly and follow these directions and the Safety Messages in this manual and on the machine. The table of contents clearly identifies each section where you can easily find the information you need.

The Occupational Safety and Health Act (OSHA 1928.51 subpart C) makes the following minimum requirements for tractor operators.

OWNER REQUIREMENTS:

1. Provide a Roll-Over-Protective Structure that meets the requirements of this Standard; and
2. Provide Seatbelts that meet the requirements of this Standard and SAE J3C; and
3. Ensure that each employee uses such Seatbelt while the tractor is moving; and
4. Ensure that each employee tightens the Seatbelt sufficiently to confine the employee to the protected area provided by the ROPS.

OPERATOR REQUIREMENTS:

1. Securely fasten seatbelt if the tractor has a ROPS.
2. Where possible, avoid operating the tractor near steep ditches, embankments, and holes.
3. Reduce speed when turning, crossing slopes, and on rough, slick, or muddy surfaces.
4. Stay off slopes too steep for safe operation.
5. Watch where you are going – especially at row ends, on roads, and around trees.
6. Do Not permit others to ride.
7. Operate the tractor smoothly – no jerky turns, starts, or stops.
8. Hitch only to the draw-bar and hitch points recommended by the tractor manufacturer.
9. When the tractor is stopped, set brakes securely and use park lock, if available



Printed in USA
© Tiger Corporation