



SIDE FLAIL ASSEMBLIES

Ford TS 100A
CAB / WOC

Current as of 04/22/05

PARTS LISTING WITH
MOUNTING AND OPERATING
INSTRUCTIONS

Tiger Corporation
3301 N. Louise Ave.
Sioux Falls, SD 57107
1-800-843-6849
1-605-336-7900
www.tiger-mowers.com

06020005

TO THE OWNER / OPERATOR / DEALER

All implements with moving parts are potentially hazardous. There is no substitute for a cautious, safe-minded operator who recognizes the potential hazards and follows reasonable safety practices. The manufacturer has designed this implement to be used with all its safety equipment properly attached to minimize the chance of accidents.

BEFORE YOU START!! Read the safety messages on the implement and shown in this manual. Observe the rules of safety and use common sense!

READ AND UNDERSTAND THIS MANUAL! Non-English speaking operators will need to GET THE MANUAL TRANSLATED as needed!



DANGER

FAILING TO FOLLOW SAFETY MESSAGES AND OPERATING INSTRUCTIONS CAN CAUSE SERIOUS BODILY INJURY OR EVEN DEATH TO OPERATOR AND OTHERS IN THE AREA.



1. Study and understand Operator's Manuals, Safety Decals, and Instructional Decals for tractor and implement to prevent misuse, abuse, and accidents. Practice before operating in a confined area or near passersby.

● Learn how to stop engine suddenly in an emergency. Be alert for passersby and especially children

2. Allow no children on or near folding mower or tractor. Allow no riders on tractor or implement. Falling off may cause serious injury or death from being run over by tractor or mower or contact with rotating blades.

3. Operate only with tractor having Roll-Over Protective Structure (ROPS) and with seat belt securely fastened to prevent injury and possible death from falling off or tractor overturn.

● Personal Protective Equipment such as Hard Hat, Safety Glasses, Safety Shoes, & Ear Plugs are recommended.

4. Block up or support raised machine and all lifted components securely before putting hands or feet under or working underneath any lifted component to prevent crushing injury or death from sudden dropping or inadvertent operation of controls. Make certain area is clear before lowering or folding

5. Before transporting, put Lift Lever in detent or full-lift position. Install Transport Safety Devices securely on folding mowers. Put Booms securely in Transport Rest.

● Folding and Boom Mowers have raised center of gravity. Slow down when turning and on hillsides.

6. Make certain that SMV sign, warning lights, and reflectors are clearly visible. Follow local traffic codes.

7. Never operate with Cutting Head or Folding Section raised if passersby, bystanders, or traffic are in the area to reduce possibility of injury or death from objects thrown by Blades under Guards or mower structure.

8. Before dismounting, secure implement in transport position or lower to ground.

● Put tractor in park or set brake, disengage PTO, stop engine, remove key, and wait until noise of rotation has ceased to prevent crushing by entanglement in rotating parts which could cause injury or death.

● Never mount or dismount a moving vehicle. Crushing from rollover may cause serious injury or death.



02967827

Warranty Information: Read and understand the complete Warranty Statement found in this manual. Fill out the Warranty Registration form in full and return it within 90 days. Make certain the Serial Number of the machine is recorded on the Warranty Card, and form that you retain.

FORWARD

This manual contains information about many features of the Tiger mowing and roadside maintenance equipment. Some of these include: Safety precautions, Assembly instructions, Operations, Maintenance and Parts. This manual will also assist you in the proper break-in, daily care, and troubleshooting of your new mower.

We recommend that you read carefully the entire manual before operating the unit. Also, time spent in becoming fully acquainted with its performance features, adjustments, and maintenance schedules will be repaid in a long and satisfactory life of the equipment.

Troubleshooting - Please, before you call, help us to help you!

Please look at the equipment to observe what is happening, then:

- Classify the problem
 - Hydraulic, electrical or mechanical - Read the trouble shooting section
 - Tractor or Truck chassis - Contact vehicle dealer

- If unable to correct the problem yourself, contact your local Tiger Dealer after gathering:
 - Machine model _____
 - Serial number _____
 - Dealer name _____
 - Detailed information about the problem including results of troubleshooting

Attention Owner / Operator / Dealer It is your obligation to read, and understand, the warranty information section located at the back of this manual denoting that the purchaser understands the safety issues relating to this machine and has received and will read a copy of this manual.

If at any time, you have a service problem with your Tiger mower, Contact your local dealer for service and parts needed.

MANUFACTURED BY:

Tiger Corporation

3301 N. Louise Ave.

Sioux Falls, SD 57107

1-800-843-6849

1-605-336-7900

www.tiger-mowers.com

DISTRIBUTED BY:

1- _____ - _____ - _____

1- _____ - _____ - _____

TABLE OF CONTENTS

SAFETY	1-1
Safety Information.....	1-2
ASSEMBLY / MOUNTING SECTION	2-1
OPERATION SECTION	3-1
MAINTENANCE SECTION	4-1
PARTS SECTION	5-1
Parts Ordering Guide.....	5-2
Parts Table of Contents.....	5-3
Common Parts Section	6-1
WARRANTY INFORMATION	7-1



1012

This symbol means:

CAUTION – YOUR SAFETY IS AT RISK!

When you see this symbol, read and follow the associated instructions carefully or personal injury or damage may result.

Tiger is a registered trademark.



SAFETY

SAFETY SECTION

SAFETY

General Safety Instructions and Practices

A safe and careful operator is the best operator. Safety is of primary importance to the manufacturer and should be to the owner / operator. Most accidents can be avoided by being aware of your equipment, your surroundings, and observing certain precautions. The first section of this manual includes a list of Safety Messages that, if followed, will help protect the operator and bystanders from injury or death. Read and understand these Safety Messages before assembling, operating or servicing this mower. This equipment should only be operated by those persons who have read the Manual, who are responsible and trained, and who know how to do so safely and responsibly.



1000

The Safety Alert Symbol combined with a Signal Word, as seen below, is used throughout this manual and on decals which are attached to the equipment. The Safety Alert Symbol means: **“ATTENTION! BECOME ALERT! YOUR SAFETY IS INVOLVED!”** The symbol and signal word are intended to warn the owner / operator of impending hazards and the degree of possible injury when operating this equipment.

Practice all usual and customary safe working precautions and above all -- remember safety is up to YOU! Only YOU can prevent serious injury or death from unsafe practices.

DANGER!



Indicates an imminently hazardous situation that, if not avoided, WILL result in DEATH OR VERY SERIOUS INJURY.

WARNING!



Indicates an imminently hazardous situation that, if not avoided, COULD result in DEATH OR SERIOUS INJURY.

CAUTION!



Indicates an imminently hazardous situation that, if not avoided, MAY result in MINOR INJURY.

IMPORTANT!

Identifies special instructions or procedures that, if not strictly observed, could result in damage to, or destruction of the machine, attachments or the environment.

NOTE: *Identifies points of particular interest for more efficient or convenient operation or repair.* (SG-1)

READ, UNDERSTAND, and FOLLOW the following Safety Messages. Serious injury or death may occur unless care is taken to follow the warnings and instructions stated in the Safety Messages. Always use good common sense to avoid hazards. (SG-2)

SAFETY INSTRUCTIONS



SAFETY

PELIGRO!



Si no lee Ingles, pida ayuda a alguien que si lo lea para que le traduzca las medidas de seguridad. (SG-3)

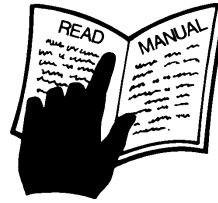

¡ LEA EL INSTRUCTIVO!

DANGER!



Never operate the Tractor or Implement until you have read and completely understand this Manual, the Tractor Operator's Manual, and each of the Safety Messages found in the Manual or on the Tractor and Implement. Learn how to stop the tractor engine suddenly in an emergency. Never allow inexperienced or untrained personnel to operate the Tractor and Implement without supervision. Make sure the operator has fully read and understands the manuals prior to operation. (SG-4)



WARNING!



Always maintain the safety decals in good readable condition. If the decals are missing, damaged, or unreadable, obtain and install replacement decals immediately. (SG-5)

WARNING!



Make certain that the "Slow Moving Vehicle" (SMV) sign is installed in such a way as to be clearly visible and legible. When transporting the Equipment use the Tractor flashing warning lights and follow all local traffic regulations. (SG-6)



WARNING!



Operate this Equipment only with a Tractor equipped with an approved roll-over-protective system (ROPS). Always wear seat belts. Serious injury or even death could result from falling off the tractor--particularly during a turnover when the operator could be pinned under the ROPS. (SG-7)



WARNING!



Do not modify or alter this Implement. Do not permit anyone to modify or alter this Implement, any of its components or any Implement function. (SG-8)

DANGER!



BEFORE leaving the tractor seat, always engage the brake and/or set the tractor transmission in parking gear, disengage the PTO, stop the engine, remove the key, and wait for all moving parts to stop. Place the tractor shift lever into a low range or parking gear to prevent the tractor from rolling. Never dismount a Tractor that is moving or while the engine is running. Operate the Tractor controls from the tractor seat only. (SG-9)

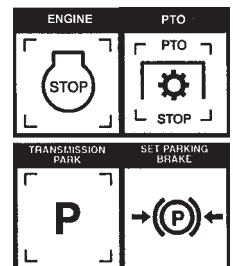

SAFETY

DANGER!



Never allow children or other persons to ride on the Tractor or Implement. Falling off can result in serious injury or death.

(SG-10)



DANGER!



Never allow children to operate or ride on the Tractor or Implement.

(SG-11)



WARNING!



Do not mount the tractor while the tractor is moving. Mount the tractor only when the tractor and all moving parts are completely stopped.

(SG-12)



DANGER!



Start tractor only when properly seated in the tractor seat. Starting a tractor in gear can result in injury or death. Read the tractor operators manual for proper starting instructions.

(SG-13)



DANGER!



Never work under the Implement, the framework, or any lifted component unless the Implement is securely supported or blocked up to prevent sudden or inadvertent falling which could cause serious injury or even death.

(SG-14)



DANGER!



Do not operate this Equipment with hydraulic oil leaking. Oil is expensive and its presence could present a hazard. Do not check for leaks with your hand! Use a piece of heavy paper or cardboard. High-pressure oil streams from breaks in the line could penetrate the skin and cause tissue damage including gangrene. If oil does penetrate the skin, have the injury treated immediately by a physician knowledgeable and skilled in this procedure.

(SG-15)



SAFETY

WARNING!



The operator and all support personnel should wear hard hats, safety shoes, safety glasses, and proper hearing protection at all times for protection from injury including injury from items thrown by the equipment. (SG-16)

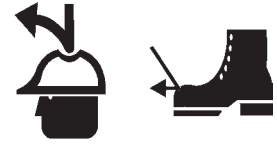

CAUTION!



PROLONGED EXPOSURE TO LOUD NOISE MAY CAUSE PERMANENT HEARING LOSS! Tractors with or without an Implement attached can often be noisy enough to cause permanent hearing loss. We recommend that you always wear hearing protection if the noise in the operator's position exceeds 80db. Noise over 85db over an extended period of time will cause severe hearing loss. Noise over 90db adjacent to the operator over an extended period of time will cause permanent or total hearing loss. *Note:* Hearing loss from loud noise [from tractors, chain saws, radios, and other such sources close to the ear] is cumulative over a lifetime without hope of natural recovery. (SG-17)



WARNING!



Transport only at safe speeds. Serious accidents and injuries can result from operating this equipment at unsafe speeds. Understand the Tractor and Implement and how it handles before transporting on streets and highways. Make sure the Tractor steering and brakes are in good condition and operate properly.



Before transporting the Tractor and Implement, determine the safe transport speeds for you and the equipment. Make sure you abide by the following rules:

1. Test the tractor at a slow speed and increase the speed slowly. Apply the brakes smoothly to determine the stopping characteristics of the Tractor and Implement. As you increase the speed of the Tractor the stopping distance increases. Determine the maximum safe transport speed for you and this equipment.
2. Test the equipment at a slow speed in turns. Increase the speed through the turn only after you determine that it is safe to operate at a higher speed. Use extreme care and reduce your speed when turning sharply to prevent the tractor and implement from turning over. Determine the maximum safe turning speed for you and this equipment before operating on roads or uneven ground.
3. Only transport the Tractor and Implement at the speeds that you have determined are safe and which allow you to properly control the equipment.

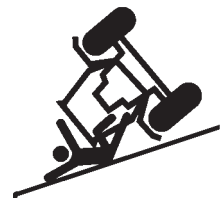

Be aware of the operating conditions. Do not operate the Tractor with weak or faulty brakes. When operating down a hill or on wet or rain slick roads, the braking distance increases: use extreme care and reduce your speed. When operating in traffic always use the Tractor's flashing warning lights and reduce your speed. Be aware of traffic around you and watch out for the other guy. (SG-19)

SAFETY

WARNING!



Never attempt to lubricate, adjust, or remove material from the Implement while it is in motion or while tractor engine is running. Make sure the tractor engine is **OFF** before working on the Implement.

(SG-20)

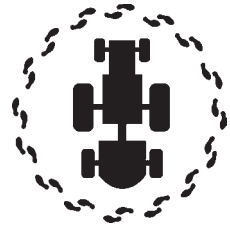

WARNING!



Periodically inspect all moving parts for wear and replace when necessary with authorized service parts. Look for loose fasteners, worn or broken parts, and leaky or loose fittings. Make sure all pins are properly secured. Serious injury may occur from not maintaining this machine in good working order. (SG-21)



WARNING!



Always read carefully and comply fully with the manufacturers instructions when handling oil, solvents, cleansers, and any other chemical agent. (SG-22)



DANGER!



Never run the tractor engine in a closed building or without adequate ventilation. The exhaust fumes can be hazardous to your health.

(SG-23)

DANGER!



KEEP AWAY FROM ROTATING ELEMENTS to prevent entanglement and possible serious injury or death.

(SG-24)



DANGER!



Never allow children to play on or around Tractor or Implement. Children can slip or fall off the Equipment and be injured or killed. Children can cause the Implement to shift or fall crushing themselves or others. (SG-25)

WARNING!



Do not exceed the rated PTO speed for the Implement. Excessive PTO speeds can cause Implement driveline or blade failures resulting in serious injury or death. (SG-26)

SAFETY

DANGER!



NEVER use drugs or alcohol immediately before or while operating the Tractor and Implement. Drugs and alcohol will affect an operator's alertness and coordination and therefore affect the operator's ability to operate the equipment safely. Before operating the Tractor or Implement, an operator on prescription or over-the-counter medication must consult a medical professional regarding any side effects of the medication that would hinder their ability to operate the Equipment safely. **NEVER** knowingly allow anyone to operate this equipment when their alertness or coordination is impaired. Serious injury or death to the operator or others could result if the operator is under the influence of drugs or alcohol. (SG-27)



DANGER!



Operate the Tractor and/or Implement controls only while properly seated in the Tractor seat with the seat belt securely fastened around you. Inadvertent movement of the Tractor or Implement may cause serious injury or death. (SG-29)

WARNING!



Mow only in conditions where you have clear visibility in daylight or with adequate artificial lighting. Never mow in darkness or foggy conditions where you cannot clearly see at least 100 yards in front and to the sides of the tractor and mower. Make sure that you can clearly see and identify passersby, steep slopes, ditches, drop-offs, overhead obstructions, power lines, debris and foreign objects. If you are unable to clearly see this type of items discontinue mowing. (SGM-1)

DANGER!



There are obvious and hidden potential hazards in the operation of this Mower. **REMEMBER!** This machine is often operated in heavy brush and in heavy weeds. The Blades of this Mower can throw objects if shields are not properly installed and maintained. Serious injury or even death may occur unless care is taken to insure the safety of the operator, bystanders, or passersby in the area. Do not operate this machine with anyone in the immediate area. Stop mowing if anyone is within 100 yards of mower. (SFL-1)



DANGER!



All Safety Shields, Guards and Safety devices including (but not limited to) - the Deflectors, Steel Guards, Gearbox Shields, PTO integral shields, and Retractable Door Shields should be used and maintained in good working condition. All safety devices should be inspected carefully at least daily for missing or broken components. Missing, broken, or worn items must be replaced at once to reduce the possibility of injury or death from thrown objects, entanglement, or blade contact. (SFL-5)

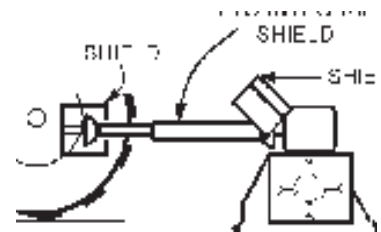

SAFETY

DANGER!



The rotating parts of this machine have been designed and tested for rugged use. However, the blades could fail upon impact with heavy, solid objects such as metal guard rails and concrete structures. Such impact could cause the broken objects to be thrown outward at very high velocities. To reduce the possibility of property damage, serious injury, or even death, never allow the cutting blades to contact such obstacles. (SGM-4)

WARNING!



Extreme care should be taken when operating near loose objects such as gravel, rocks, wire, and other debris. Inspect the area before mowing. Foreign objects should be removed from the site to prevent machine damage and/or bodily injury or even death. Any objects that cannot be removed must be clearly marked and carefully avoided by the operator. Stop mowing immediately if blades strike a foreign object. Repair all damage and make certain rotor or blade carrier is balanced before resuming mowing. (SGM-5)



WARNING!



Many varied objects, such as wire, cable, rope, or chains, can become entangled in the operating parts of the mower head. These items could then swing outside the housing at greater velocities than the blades. Such a situation is extremely hazardous and could result in serious injury or even death. Inspect the cutting area for such objects before mowing. Remove any like object from the site. Never allow the cutting blades to contact such items. (SGM-6)

WARNING!



Mow at the speed that you can safely operate and control the tractor and mower. Safe mowing speed depends on terrain condition and grass type, density, and height of cut. Normal ground speed range is from 0 to 5 mph. Use slow mowing speeds when operating on or near steep slopes, ditches, drop-offs, overhead obstructions, power lines, or when debris and foreign objects are to be avoided. (SGM-7)

WARNING!



Avoid mowing in reverse direction when possible. Check to make sure there are no persons behind the mower and use extreme care when mowing in reverse. Mow only at a slow ground speed where you can safely operate and control the tractor and mower. Never mow an area that you have not inspected and removed debris or foreign material. (SGM-8)

DANGER!



Replace bent or broken blade with new blades. NEVER ATTEMPT TO STRAIGHTEN OR WELD ON BLADES SINCE THIS WILL LIKELY CRACK OR OTHERWISE DAMAGE THE BLADE WITH SUBSEQUENT FAILURE AND POSSIBLE SERIOUS INJURY FROM THROWN BLADES. (SGM-10)

WARNING!



Do not mow with two machines in the same area except with Cab tractors with the windows closed. (SGM-11)

SAFETY

DANGER!



Flail Mowers are capable under adverse conditions of throwing objects for great distances (100 yards or more) and causing serious injury or death. Follow safety messages carefully.

STOP MOWING IF PASSERSBY ARE WITHIN 100 YARDS UNLESS:

- Front and Rear Deflectors are installed and in good, working condition;
- Mower Head is running close to and parallel to the ground without exposed Blades;
- Passersby are outside the existing thrown-object zone;
- All areas have been thoroughly inspected and all foreign material such as rocks, cans, glass, and general debris has been removed.

NOTE: Where there are grass and weeds high enough to hide debris that could be struck by the blades, the area should be: inspected and large debris removed, mowed at an intermediate height, inspected closely with any remaining debris being removed, and mowed again at desired final height. (SFL-6)



DANGER!



Do not put hands or feet under mower decks. Blade Contact can result in serious injury or even death. Stay away until all motion has stopped and the decks are securely blocked up. (SFL-2)



WARNING!



Each Rear Wheel must have a minimum of 1,000 pounds contact with the surface to prevent lateral instability and possible tip-over which could result in serious bodily injury or even death. Widen the wheel tread and add weights if needed. Refer to the mounting instructions or call Customer Service if you need assistance with Counterweight Procedure. (SFL-3)



WARNING!



Do not operate Mower if excessive vibration exists. Shut down PTO and the Tractor engine. Inspect the Mower to determine the source of the vibration. If Mower blades are missing or damaged replace them immediately. Do not operate the mower until the blades have been replaced and the Mower operates smoothly. Operating the Mower with excessive vibration can result in component failure and broken objects to be thrown outward at very high velocities. To reduce the possibility of property damage, serious injury, or even death, never allow the Mower to be operated with blades missing. (SFL-4)

WARNING!



Be particularly careful when transporting the Implement with the Tractor. Turn curves or go up hills only at a low speed and using a gradual steering angle. Rear mounted implements move the center of gravity to the rear and remove weight from the front wheels. Make certain, by adding front ballast, that at least 20% of the tractor's weight is on the front wheels to prevent rearing up, loss of steering control or Tractor tip-over. Slow down on rough or uneven surfaces to prevent loss of steering control which could result in property damage or possible injury. Do not transport unless 3-Point lift lever is fully raised and in the latched transport position. Dropping implement in transport can cause serious damage to the tractor and/or Implement and possibly cause the operator or others to be injured or killed. (S3PT-2)

SAFETY

DANGER!



Always disconnect the main PTO Driveline from the Tractor before performing service on the Mower. Never work on the Mower with the tractor PTO driveline connected and running. Blades or Drivelines could turn without warning and cause immediate entanglement, injury or death.

(SRM-3)

WARNING!



Do not let the Blades turn when the Mower Deck is raised for any reason, including clearance or for turning. Raising the Mower deck exposes the Cutting Blades which creates a potentially serious hazard and could cause serious injury or even death from objects thrown from the Blades.

(SRM-7)



WARNING!



Never leave Tractor and Implement unattended while the implement is in the lifted position. Accidental operation of lifting lever or a hydraulic failure may cause sudden drop of unit with injury or death by crushing. To properly park the implement when disconnecting it from the tractor, lower the stand and put the retaining pin securely in place, or put a secure support under the A-Frame. Lower the implement carefully to the ground. Do not put hands or feet under lifted components.

(SPT-1)

DANGER!



Make sure the PTO shield, integral driveline shields, and input shields are installed when using PTO-driven equipment. Always replace any shield if it is damaged or missing.

(S3PT-8)



WARNING!



Relieve hydraulic pressure prior to doing any maintenance or repair work on the Implement. Place the Implement on the ground or securely blocked up, disengage the PTO, and turn off the tractor engine. Push and pull the Remote Cylinder lever in and out several times prior to starting any maintenance or repair work.

(S3PT-9)



WARNING!



Use extreme care when lowering or unfolding the implement's wings. Make sure no bystanders are close by or underneath the wings. Allow ample clearance around the implement when folding or unfolding the wings. Use extreme caution around buildings or overhead power lines.

(S3PT-5)

DANGER!



When the Wings are folded for transport, the center of gravity is raised and the possibility of overturn is increased. Drive slowly and use extreme caution when turning on hillsides. Overturning the Implement could cause the Implement to overturn the Tractor and vice versa resulting in serious injury or even death. Never fold wings on a hillside...the Implement may overturn.

(STI-2)

DANGER!



DO NOT allow any person under a folded wing unless wing is securely locked up or supported. **DO NOT** approach the Implement unless the Tractor is turned off and all motion has ceased. Never work under the frame work, or any lifted component unless the implement is securely supported or blocked up. A sudden or inadvertent fall by any of these components could cause serious injury or even death.

(STI-3)



SAFETY

DANGER!



The flail cutter shaft is designed for standard rotation (same rotation as the tractor wheels during forward travel). **Never operate the cutter shaft in the reverse rotation.** Operating this mower in reverse rotation may cause objects to be thrown out the front of the mower head.



WARNING!



The rotating parts of this machine continue to rotate even after the PTO has been turned off. The operator should remain in his seat for 60 seconds after the brake has been set, the PTO disengaged, the tractor turned off, and all evidence of rotation has ceased.

(3PT-10)

“Wait a minute...Save a life!”

WARNING!



Engine Exhaust, some of its constituents, and certain components contain or emit chemicals known to the state of California to cause cancer and birth or other reproductive harm.

WARNING!



Battery posts, terminals and related accessories contain lead and lead compounds, chemicals known to the state of California to cause cancer and birth or other reproductive harm. **Wash hands after handling!**

Tiger mowers use balanced and matched system components for blade carriers, blades, cutter-shafts, knives, knife hangers, rollers, drive-train components and bearings. These parts are made and tested to Tiger specifications. Non-genuine “will fit” parts do not consistently meet these specifications. The use of “will fit” parts may reduce mower performance, void mower warranties and present a safety hazard. Use genuine Tiger mower parts for economy and safety.

SEE YOUR  DEALER

In addition to the design and configuration of this Implement, including Safety Signs and Safety Equipment, hazard control and accident prevention are dependent upon the awareness, concern, prudence, and proper training of personnel involved in the operation, transport, maintenance, and storage of the machine. Refer also to Safety Messages and operation instruction in each of the appropriate sections of the T ractor and Equipment Manuals. Pay close attention to the Safety Signs affixed to the T ractor and Equipment. (SG-18)

SAFETY

PART NO.
LOCATION

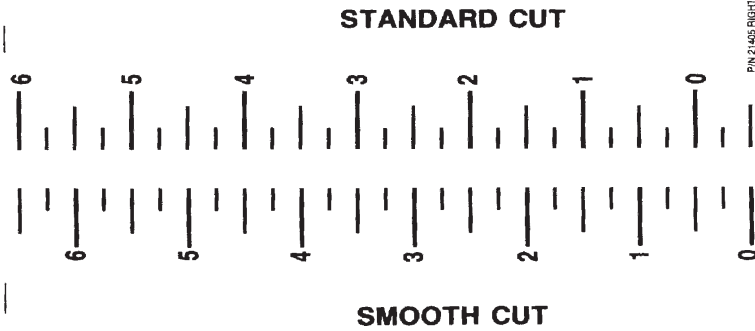

21405
MOWER DECK

**DO NOT LUBRICATE WITH AUTOMATIC
GREASE GUN. GREASE WITH HAND
GREASE GUN ONLY.**

P/N22839

22839
MOWER DECK



22840
INSIDE OF CAB

WARNING

INSPECT REAR FLAP FREQUENTLY TO BE SURE IT IS IN SAFE WORKING CONDITION. DO NOT OPERATE MOWER WITH FLAP REMOVED OR WORN.

24028

24028
MOWER DECK

SAFETY



PART NO.
LOCATION

10" x 5.5" 31522
MOWER DECK
18.25" x10" 31523
HYDRAULIC TANK



42350
MOWER DECK

MOWING SAFETY TIPS

- Read & understand the Operators Manual.
- Wear Your Seat Belt.
- Keep all shields and guards in place.
- Make sure equipment is in proper working condition.
- Never attempt to get off or on a moving tractor.
- Never allow riders on tractor or equipment.
- Only start the tractor from the seat with the key.
- Always inspect the area before mowing. Remove all foreign debris.
- Always keep bystanders and coworkers a minimum of 300 feet away.
- Never allow the mower blades to contact solid objects or foreign material.
- Never approach rotating elements.
- Disengage the PTO, place transmission in "Park", set parking brake, shut off engine, and remove key and wait until all rotating motion has stopped before leaving seat.



33743

33743
INSIDE OF CAB

SAFETY

PART NO.
LOCATION



42399
MOWER DECK



42400
MOWER DECK



6T3217
MOWER DECK



6T3219
INSIDE OF CAB

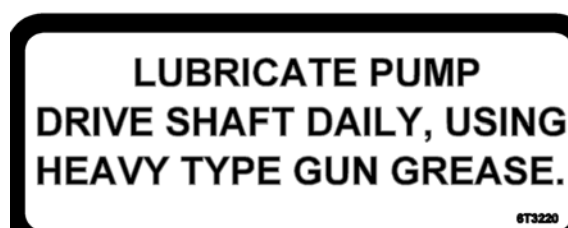

6T3220
FRONT PUMP MOUNT

SAFETY



PART NO.
LOCATION

6T3221
INSIDE OF CAB

NOTICE:
Engine will not
start when mower
is engaged.



6T3222
INSIDE OF CAB

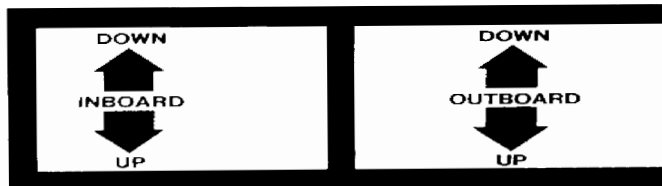

6T3223
INSIDE OF CAB



6T3224
MOWER DECK

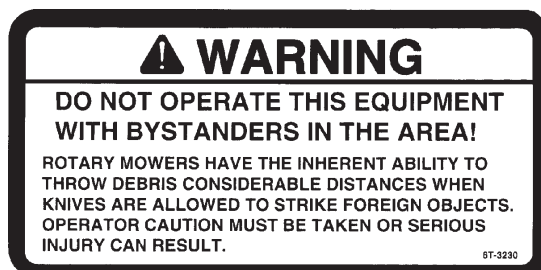

6T3230
INSIDE OF CAB

SAFETY

PART NO.
LOCATION



6T3233
HYDRAULIC TANK



6T3234
INSIDE OF CAB



6T3236
MOWER DECK
HYDRAULIC TANK



6T3243
INSIDE OF CAB

SAFETY



Tiger Corporation

800-843-6849

www.tiger-mowers.com

Description	Application	General Specification	Recommended Lubricant
Tractor Hydraulics	Reservoir	JD-20C	Mobilfluid® 424
Mower Hydraulics Cold Temperatures 0°F Start-up Normal Temperatures 10°F Start-up Normal Temperatures 15°F Start-up High Operating Temperatures Above 90°F Ambient	Reservoir	ISO 46 Anti-Wear/ Low Temp JD-20C ISO 46 Anti-Wear ISO 100 Anti-Wear	Mobil DTE® 15M Mobilfluid® 424 Mobil DTE® 25 Mobil DTE® 18M
Flail Rear Gearbox	Reservoir	PAO Synthetic Extreme Pressure Gear Lube	Mobilube SHC® 75W-90, Mobil 1 Synthetic Gear Lubricant
Cutter Shaft and Ground Roller Shaft (Flail)	Grease Gun	Lithium Complex, NLGI 2 ISO 320	Mobilgrease® CM-S
Drive Shaft Coupler (Rotary and Flail)	Grease Gun	Lithium Complex, NLGI 2 ISO 320	Mobilgrease® CM-S
Boom Swivel, Boom Cylinder Pivots (Rotary and Flail Boom Type)	Grease Gun	Lithium Complex, NLGI 2 ISO 320	Mobilgrease® CM-S
Deck Boom Pivot & Deck Stop Adjustment (Rotary and Flail)	Grease Gun	Lithium Complex, NLGI 2 ISO 320	Mobilgrease® CM-S
Deck Spindle (Rotary)	Grease Gun	Tiger Spindle Lubricant	Mobilith SHC 220

For Mobil product information, availability, or technical information, call 1-800-662-4525.

Tiger PN 34852

34852

HYDRAULIC TANK

<div style="background-color: red; color: white; padding: 5px; font-weight: bold; font-size: 1.2em;">⚠ DANGER</div> <p style="font-weight: bold; margin-top: 10px;">THROWN OBJECT HAZARD</p> <p>Do not operate mower when cutter shaft is in reverse rotation unless:</p> <ul style="list-style-type: none"> Reverse Rotation Front Guard is in place, and Guard is in good condition 		<div style="background-color: red; color: white; padding: 5px; font-weight: bold; font-size: 1.2em;">⚠ PELIGRO</div> <p style="font-weight: bold; margin-top: 10px;">RIESGO DE OBJETO LANZADO</p> <p>No funcione el cortacésped cuando el eje de cortador esta en rotación inverso al menos que:</p> <ul style="list-style-type: none"> El Guardia Delantero de Rotación Inversa esta en su lugar y El guardia esta en buenas condiciones
<p>Reverse Rotation Front Guard</p>	<p>06550054</p>	<p>Guardia Delantero De Rotación Inverso</p>

06550054

ON MOWER HEAD

SAFETY

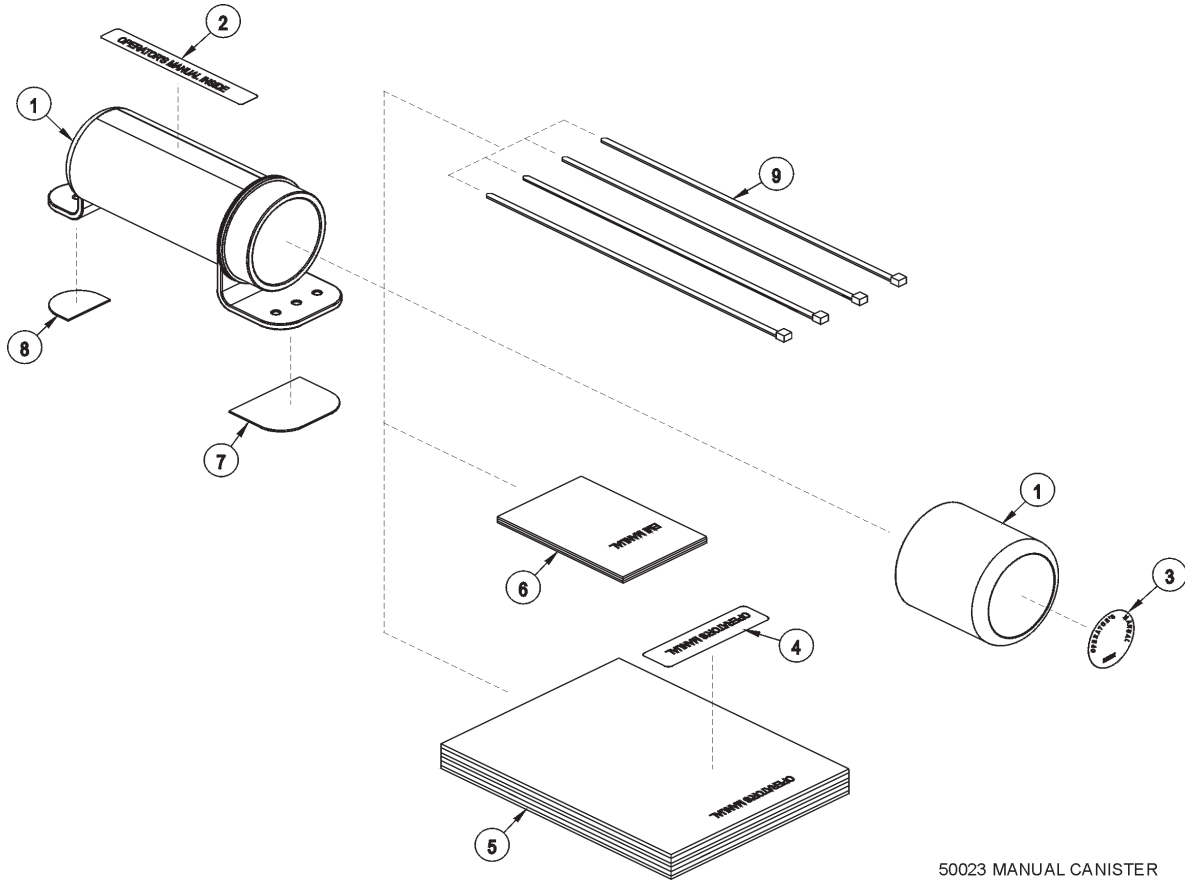

ITEM	PART NO.	QTY.	DESCRIPTION
	50023	AVAIL	MANUAL CANISTER COMPLETE
1	00776031	1	ROUND MANUAL CANISTER
	33997	1	DECAL, SHEET, MANUAL CANISTER
2		*	DECAL
3		*	DECAL
4		*	DECAL
5	*	AVAIL	SPECIFIC PRODUCT MANUAL
6	33753	1	E M I SAFETY MANUAL
7	34296	1	FRONT ADHESIVE PAD
8	34297	1	REAR ADHESIVE PAD
9	6T1823	4	ZIPTIE 14" LONG

NOTE:

The manual canister can be bolted, zip tied or adhered to a variety of surfaces. Locate a protected area within the view of the operator. Then select an installation method and attach the canister. **CAUTION - AVOID DRILLING HOLES INTO UNKNOWN AREAS**, wires and other parts may be located behind these areas. When adhering the canister to a surface, thoroughly clean that surface before installing the canister.

SAFETY

FEDERAL LAWS AND REGULATIONS

This section is intended to explain in broad terms the concept and effect of federal laws and regulations concerning employer and employee equipment operators. This section is not intended as a legal interpretation of the law and should not be considered as such.

Employer-Employee Operator Regulations

U.S. Public Law 91-596 (The Williams-Steiger Occupational and Health Act of 1970) OSHA

This Act Seeks:

“...to assure so far as possible every working man and woman in the nation safe and healthful working conditions and to preserve our human resources...”

DUTIES

Sec. 5 (a) Each employer-

(1) shall furnish to each of his employees employment and a place of employment which are free from recognized hazards that are causing or are likely to cause death or serious physical harm to his employees;

(2) shall comply with occupational safety and health standards promulgated under this Act.

(b) Each employee shall comply with occupational safety and health standards and all rules, regulations and orders issued pursuant to this Act which are applicable to his own actions and conduct.

OSHA Regulations

OSHA regulations state in part: “At the time of initial assignment and at least annually thereafter, the employer shall instruct every employee in the safe operation and servicing of all equipment with which the employee is, or will be involved.”

Employer Responsibilities:

To ensure employee safety during Tractor and Implement operation, it is the employer’s responsibility to:

1. Train the employee in the proper and safe operation of the Tractor and Implement.
2. Require that the employee read and fully understand the Tractor and Implement Operator’s manual.
3. Permit only qualified and properly trained employees to operate the Tractor and Implement.
4. Maintain the Tractor and Implement in a safe operational condition and maintain all shields and guards on the equipment.
5. Ensure the Tractor is equipped with a functional ROPS and seat belt and require that the employee operator securely fasten the safety belt and operate with the ROPS in the raised position at all times.
6. Forbid the employee operator to carry additional riders on the Tractor or Implement.
7. Provide the required tools to maintain the Tractor and Implement in a good safe working condition and provide the necessary support devices to secure the equipment safely while performing repairs and service.

Child Labor Under 16 Years of Age

Some regulations specify that no one under the age of 16 may operate power machinery. It is your responsibility to know what these regulations are in your own area or situation. (Refer to U.S. Dept. of Labor, Employment Standard Administration, Wage & Home Division, Child Labor Bulletin #102.)

SAFETY

ASSEMBLY SECTION

ASSEMBLY

Before attempting to mount or service your Tiger mower, it is important to read and understand all of the information in the Safety section of this manual.

Check complete shipment list against the packing list to make sure there are no shortages. Make certain the tractor model is the appropriate one for the mower received!

CAUTION!



Use a floor jack, hoist or fork lift to lift or raise heavy parts whenever possible whether mentioned or not.

Read and understand the entire assembly section instructions before attempting to mount your Tiger mower. Refer to the parts section of this manual for detailed illustrations to locate all parts.

TRACTOR PREPARATION

- A: Remove right hand steps.
- B: Disconnect battery cables.
- C: Remove battery, battery box and existing bracket.
- D: Remove engine side panels, or raise hood to access front pulley.
- E: Remove plugs from tractor casting where main frame and pump mount will be attached.
- F: Install battery bracket supplied in the kit using existing hardware.

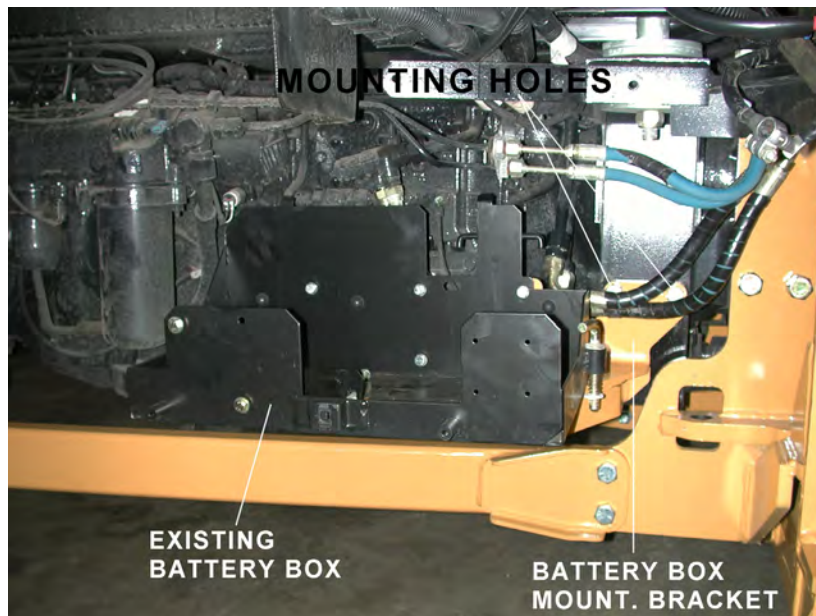

ASSEMBLY

ADJUSTING REAR WHEELS

Raise rear of tractor onto jack-stands. Follow the instructions in the tractor owners manual for adjusting tires and rims to 72" center for side mounted mowers and 79.8" for boom mowers. NOTE: This may require switching the wheels to opposite sides of tractor.

CRANKSHAFT ADAPTER

If necessary remove the four cap-screws from the crankshaft pulley. Then install the crankshaft adapter and spacer to the pulley with cap-screws and lock-washers as shown in the parts section.

CABLE CONTROL LEVER STAND

Place the front edge of the support bracket 2 $\frac{3}{4}$ " back from the lower right front window. Rotate stand to be 2" from the right door frame as shown below. Be sure that the location of the stand will allow clearance between the cable control handles and all existing interior levers, etc.

Drill 3 holes to match control bracket and secure with cap-screws and nylock nuts noted in parts section.

Cut a 2 $\frac{1}{4}$ " hole in the floor from inside the cab. This hole is to be located 2-1/2" up from floor, and 4" from the metal edge by the right door. Install trim lock around the metal edges of the hole, then route the cables through the hole. Next, wrap the cables with the 6" split hose at the point they pass through the hole, and secure with zip-ties.

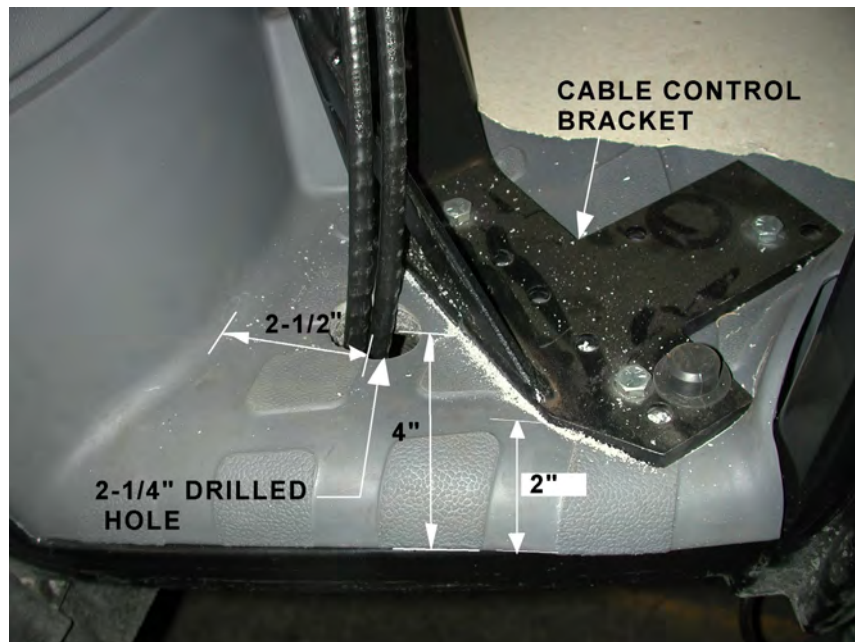

ASSEMBLY

LIFT VALVE MOUNT

Install the valve mounting bracket to the inside of the right and left rear fender frame tube as shown below. Align the valve mounting plate with the drilled holes. Mark the center of one of the holes above and in line with the slotted holes in the valve plate. Do not use any holes that will be used to mount the valve on the plate.

Mount the lift valve with the supplied hardware. Refer the parts section for the details.

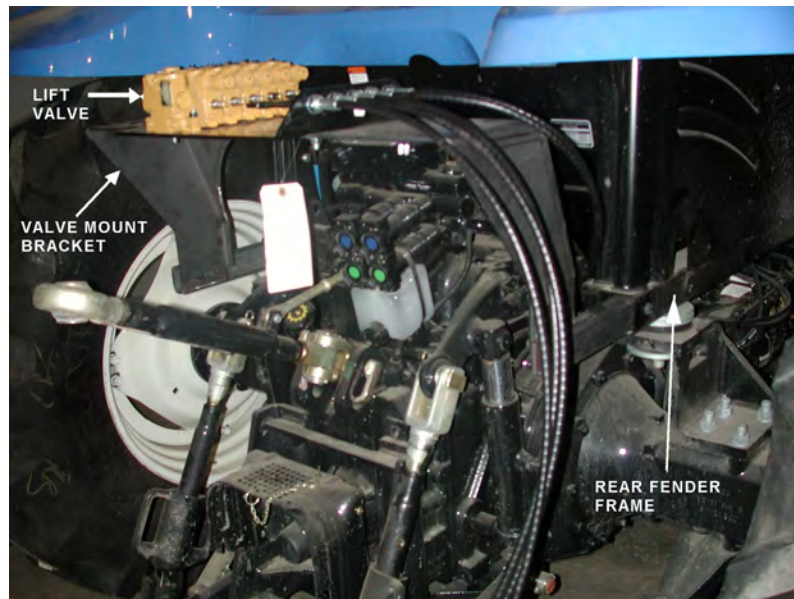

MAIN FRAME MOUNTING

Raise front of tractor as needed and slide the main frame under tractor from right hand side. With an overhead hoist and / or jack-stands, raise the frame up to the correctly matching mounting holes. Install spacer blocks and shims as needed. Install cap-screws and all other hardware as shown in main frame parts section. Remove the cap-screws one at a time and apply a thread locking agent, then reinsert the cap-screws and tighten / torque to values noted in the torque chart located in the maintenance section of this manual.

SOLENOID BRAKE VALVE

Install a solenoid valve the mounting bracket with the supplied hardware. While installing fittings to the brake valve, the electrical coil on the spool must be removed to make room. When reinstalling the coil, it is important to use no more than 5 ft. lbs. (or 60 in. lbs.) torque. Over torque to the coil will result in hydraulic failure of spool.

ASSEMBLY

WEATHER-PACK/METRI-PACK ASSEMBLY

These instructions apply to both Weather-Pack and Metri-pack connectors.

NOTE: Use the specific tool for the type of connector you are assembling.

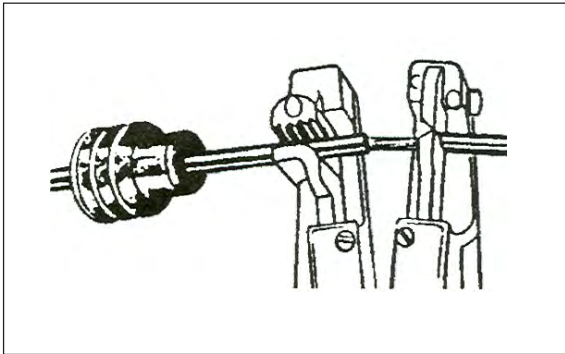

1. Apply seal to cable, before stripping insulation.



2. Align seal with cable insulation.

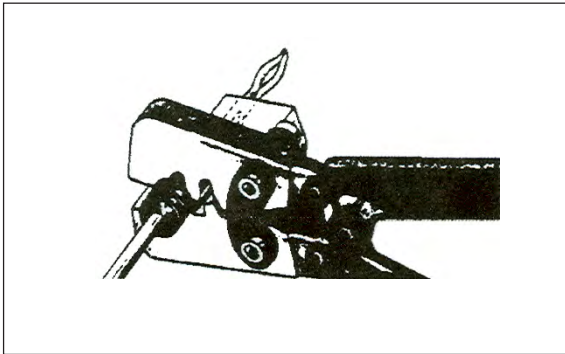

3. Put terminal in crimping tool, then position wire and seal in place.

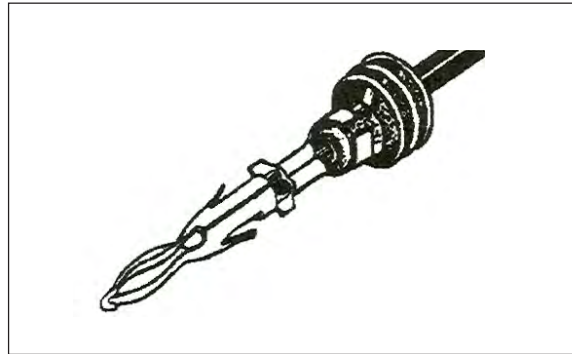

4. Crimp and visually inspect for a good crimp before installing in connector body.

ASSEMBLY

POLY-CARBONATE SAFETY WINDOW

NOTE: This should be done before mounting the main frame.

1. Disconnect gas shock at door. Remove the right side cab door from tractor cab by removing hinge pins.
2. Remove the existing hardware and discard factory glass door.
3. Place small bead of adhesive seal in the bottom of the trim lock bubble bead.
4. Install trim lock bubble seal on polycarbonate starting at the center bottom horizontal portion.
5. Install existing hardware removed from glass door on the polycarbonate.
6. Install the polycarbonate assembly in the cab with existing and supplied hardware.
7. Press polycarbonate into place at upper front corner.
8. Then drill $\frac{3}{16}$ " pilot hole through polycarbonate and corner gusset of door jam. 9. Locate hole $1\frac{1}{4}$ " from the edge of the lower rounded feature of the corner gusset and center it from each end. Then drill out hole in polycarbonate with $\frac{15}{32}$ " diameter bit that is **ONLY** used for polycarbonate.
10. Drill out hole in gusset with $\frac{3}{8}$ " diameter bit for steel.
11. Install the poly door into place where factory door was removed (upper right rear first). Refer the parts section for the details.
12. Install grommet into hole in polycarbonate. Then install supplied $\frac{1}{4}$ " nut into corner gusset.
13. Secure upper right corner with supplied washer and capscrew. Refer Parts section for the details.

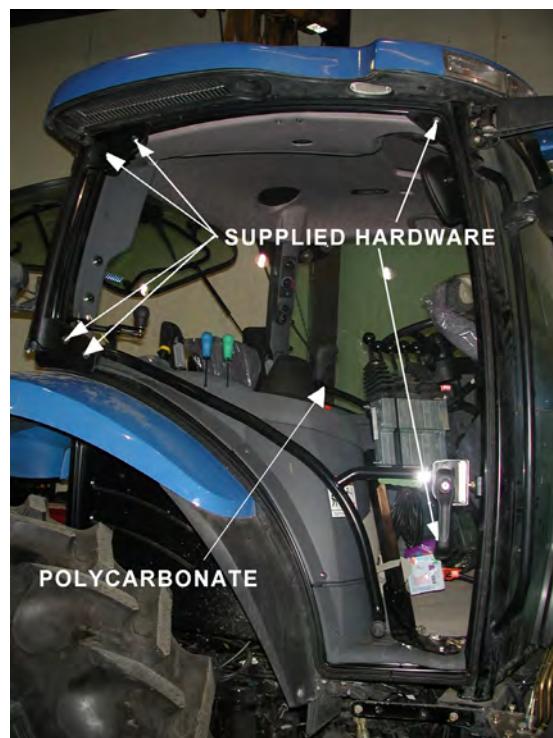

ASSEMBLY

MIRROR MOUNT

1. Remove the existing mirror bracket and mirror from the cab.
2. Remove the mirror and knob from existing bracket.
3. Install the supplied bracket using supplied hardware on the cab as shown below.
4. Install the mirror with the knob on the supplied bracket as shown below.
Refer the parts section for details.



FRONT WORKLAMP RELOCATION

1. Cut the right side front hand rail from the bottom of worklamp to the bottom of the hand rail.
2. Bend the hand rail inside to avoid the boom collision with the worklamp.

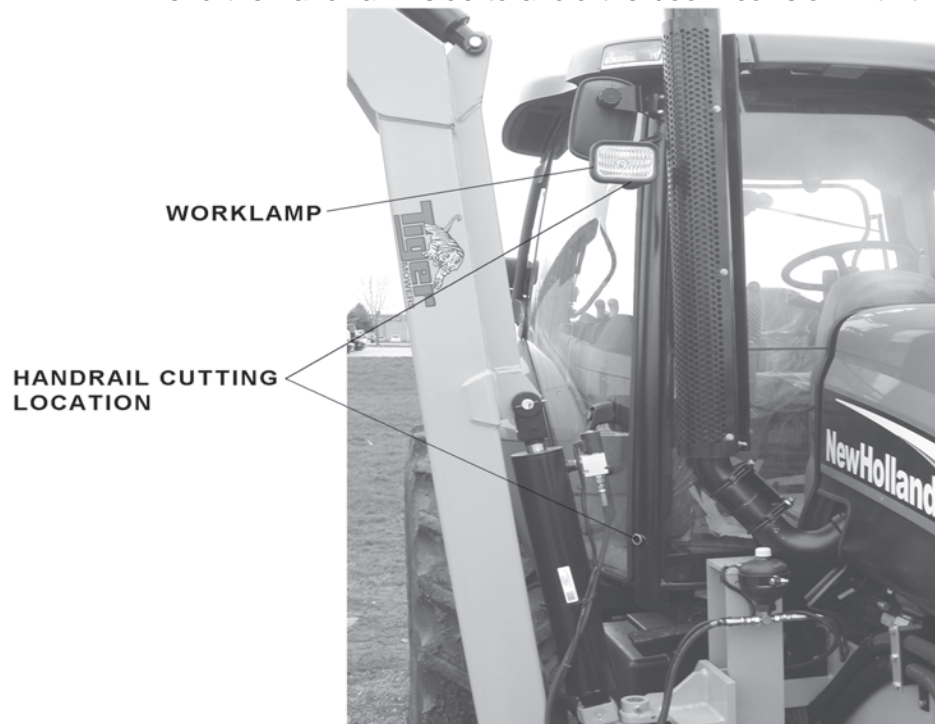

ASSEMBLY

EXHAUST MOUNT

NOTE: This should be done after mounting the main frame.

1. Cut the tractor hood as shown in pic. # 1 to accommodate modified exhaust turbo tube.
2. Remove the muffler from existing turbo tube.
3. Remove existing turbo tube from tractor turbo.
4. Install the exhaust mounting bracket and supporting brace.
5. Cut the existing tube at turbo end $4\text{-}\frac{3}{8}$ " from hole center as shown in pic. # 2 and 3. Discard remaining portion of existing tube.
6. Install the turbo end of existing tube to the tractor turbo.
7. Connect the supplied tube to the turbo end of existing tube using the sealing clamp as shown in pic. # 4. Do not tighten the hardware.
8. Install the exhaust clamp to the exhaust mounting bracket with the supplied hardware. Refer parts section for the details.
9. Tighten the turbo existing hardware first and then the rest of the hardware.
10. Cut the muffler sweep off at the top and replace with a raincap, if necessary for shipping, as shown in pic. # 5. Then install muffler to the turbo tube with the existing hardware.



Picture # 1

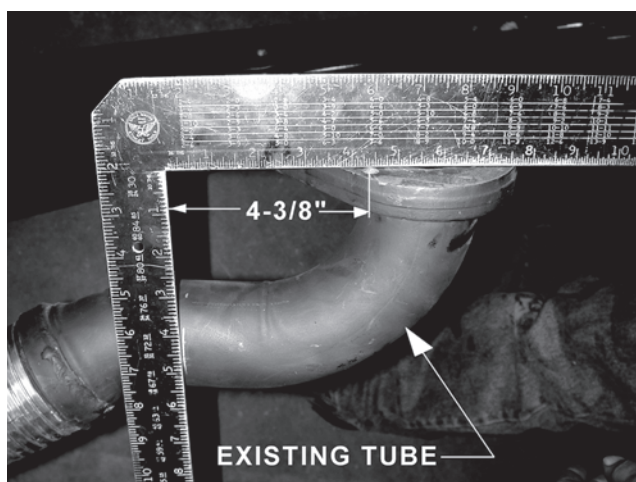

Picture # 2

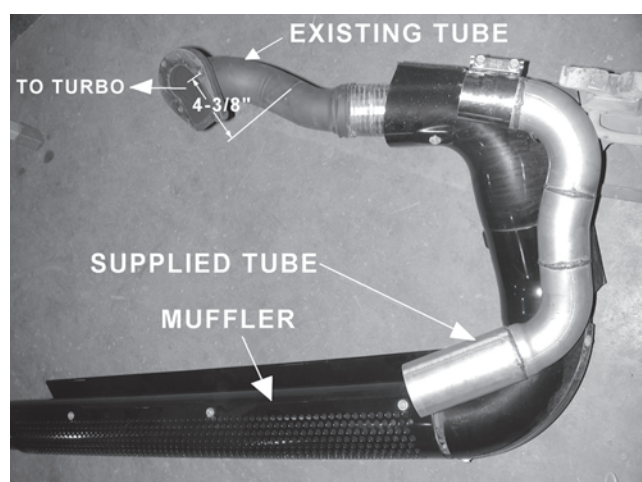

Picture # 3

ASSEMBLY

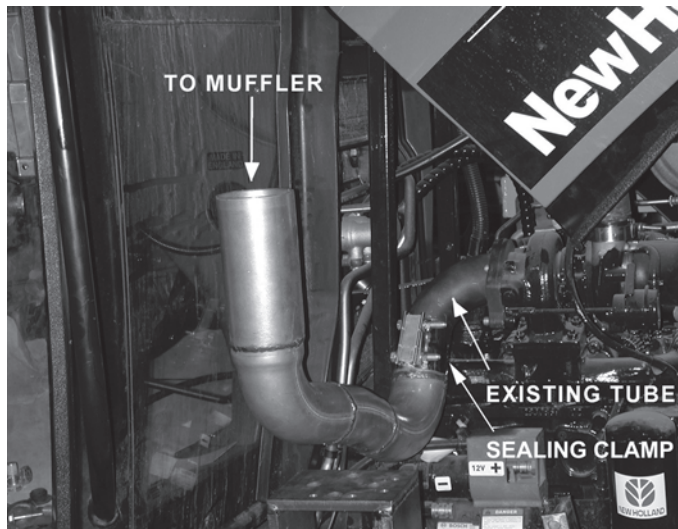

Picture # 4

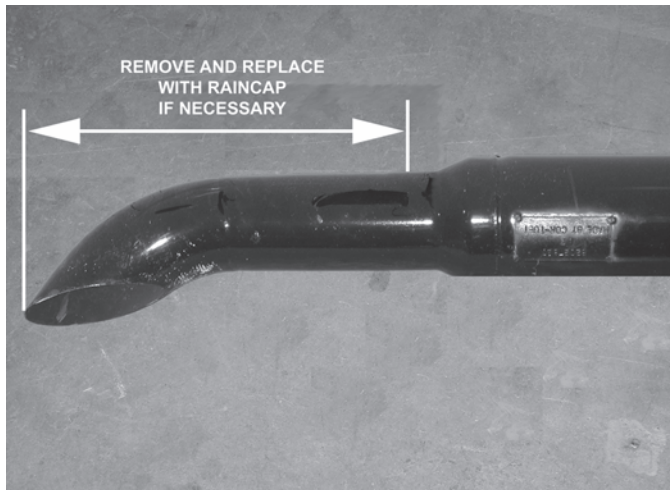

Picture # 5

ASSEMBLY

SWITCH MOUNTING

Refer to the parts section for wiring diagrams. Remove top instrument panel (tach, and hour meter) for access to the wires.

Route the red and green wire from the switch box wires from the switch box to the bottom right corner of the instrument panel near window. Connect the red wire to the white wire. (hot when key in on position)

NOTE ONLY FOR ELECTRONIC VALVE: +12 VOLTS ELECTRICAL POWER MUST BE TAKEN FROM A SOURCE LOCATION WHERE IT IS LIVE ONLY WHEN THE IGNITION SWITCH IS IN THE "ON" POSITION. THIS WIRE MUST BE FUSED AT THE SOURCE LOCATION.

Route the white wire to connected the hydraulic solenoid valve.

The switch box is to be secured to the operators side of the control handles, or valve stand.

The green wires will connect to the neutral safety switch wires (white with yellow



BEFORE WIRING

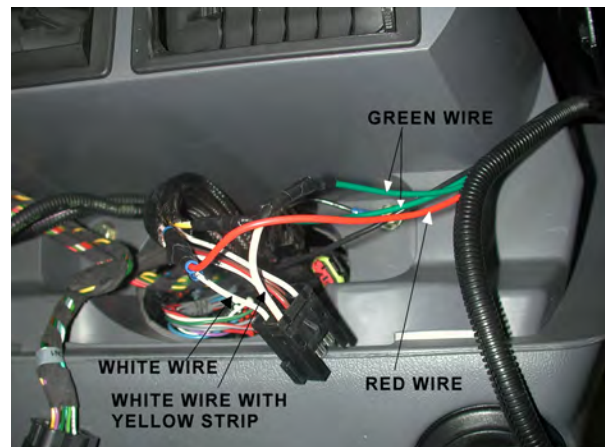

AFTER WIRING

HYDRAULIC TANK INSTALLATION

Install all fittings and tubes into tank and tank filter as shown in parts section illustration. Install the 2 sight glass into back side of the tank. Install the temperature sensor or pipe plug into the side of the tank.

Place the tank in the mounting bracket on the main frame with fittings toward tractor and filter toward the cab.

Secure the tank in the mounting bracket with the tank strap and nylock nuts.

Install the filter gauge into the filter housing so that it points to the rear of the tractor and is clearly visible to the operator.

Locate the tank breather and reducer bushing (bushing may be already installed in the tank along with many of the for-mentioned parts). These will be installed after tank is filled with oil. The oil level must be visible in lower sight glass but not visible in upper sight glass.

ASSEMBLY

SIDE ROTARY OR FLAIL HYDRAULIC DIAGRAM

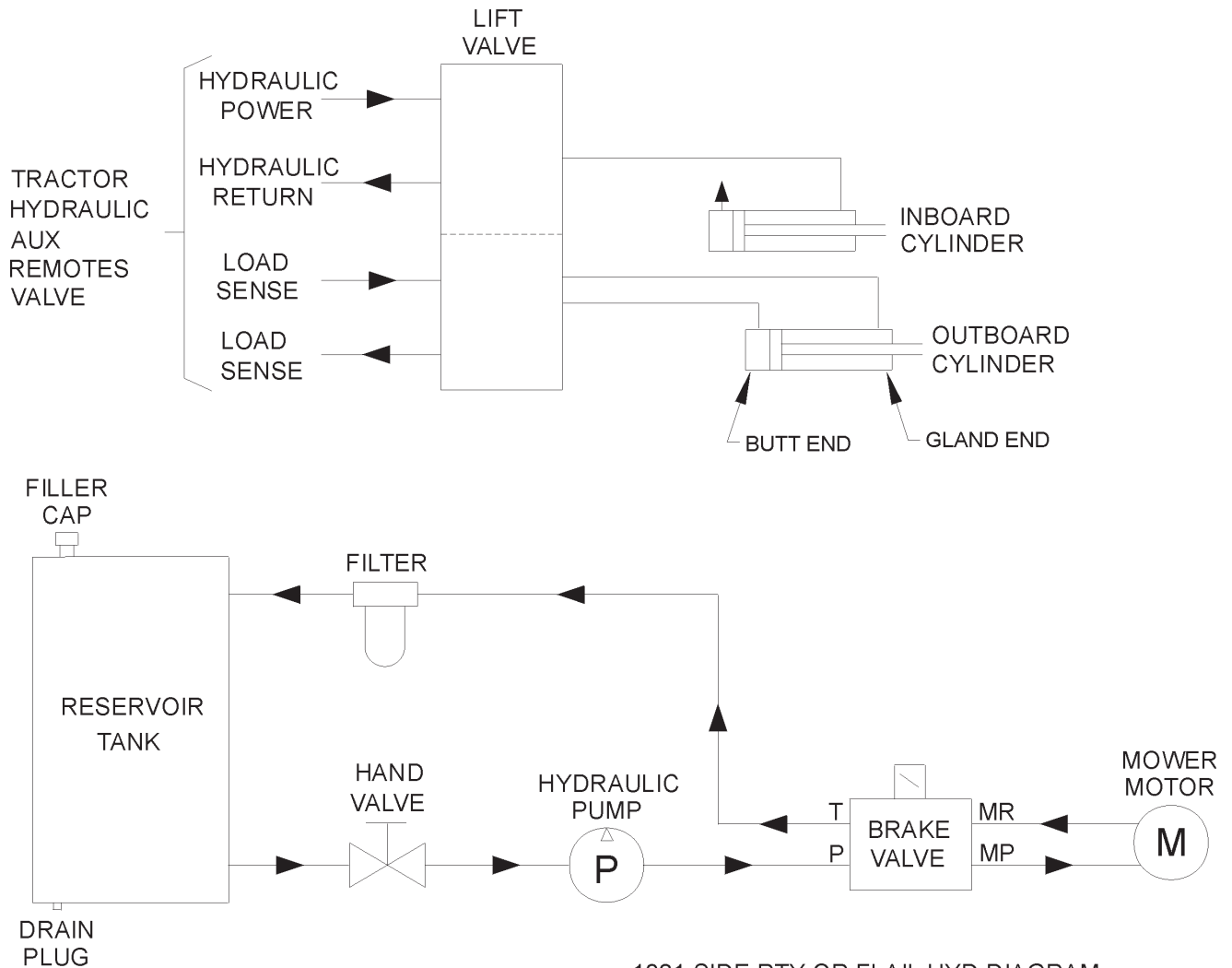

1321 SIDE RTY OR FLAIL HYD DIAGRAM

TEMPERATURE GAUGE MOUNTING

(OPTIONAL)

Mount the temperature gauge where it is clearly visible to the operator. Attach the green (-) wire from the negative post on the gauge to a grounded bolt on the tractor frame. Remove paint if needed to make a good ground.

Remove the pipe plug from the side of the hydraulic reservoir, and install the temperature sensor using thread sealing tape. Run the white wire from the (S) sensor post of the gauge to the temperature sensor on the hydraulic reservoir tank.

ASSEMBLY

FRONT PUMP MOUNTING

Install the pump mounting bracket on the front of the tractor with cap-screws and lock-washers as shown in the parts section illustration. DO NOT tighten fasteners at this time.

Slide the pump drive shaft into the crankshaft adapter. The end with the shorter splines should be inserted into the adapter (if applicable).

Slide the splined drive shaft coupler onto the pump drive shaft. Install the pump onto the mounting bracket. NOTE: the shaft is offset to one direction, the pump should be installed with the offset side on top. Install hardware for securing pump to the pump mount, DO NOT tighten.

Align pump so that splined coupling can be moved back and forth by hand. Tighten pump mounting bolts in succession rechecking for spline coupling movement. Remove the pump mounting bracket bolts one at a time and apply a tread locking agent. Tighten these bolts in succession, again checking for free movement in the drive shaft. After all bolts are torqued, the end play on the drive shaft should be 1/16" to 1/8", and coupler should move freely with hand pressure. If end play is less than 1/16", grind the end of the shaft to achieve the proper end play. If there is more than 1/4" of end play, return the shaft with specifications for a longer shaft.

CAUTION: DO NOT START THE TRACTOR UNTIL ALL HOSES ARE ATTACHED, TANK IS FILLED WITH PROPER OIL AND BALL VALVES ARE OPEN! STARTING AT THIS TIME WILL CAUSE SERIOUS DAMAGE TO THE PUMP.

GENERAL HOSE INSTALLATION

Refer to the parts section for detailed information about hoses and fittings for this application.

When mounting the suction hose between the pump and the tank, the stainless steel bands that are provided must be used. CAUTION: DO NOT use regular hose clamps for this purpose.

For protection of hoses in contact with metal edges, wrap hoses with spit hose sections and fasten with hose clamps or zip ties as needed.

ASSEMBLY

INSTALLING O-RING FITTINGS

Installing straight, 45 degree and 90 degree O-ring fittings requires that the O-ring, washer and nut (A) be up against the swivel body (B). Insert the swivel and turn in until the swivel is pointed in the right direction and the O-ring contact is made. Hold swivel in set direction with a wrench and turn the O-ring nut away from the swivel body and carefully tighten.

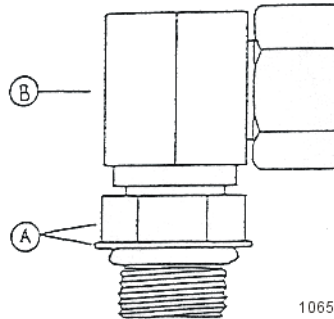

SUB-FRAME AXLE BRACE MTG.

These units require the lower rear axle brace to be mounted under the right rear axle of the tractor. The other end of the axle brace mounts to the main frame lower right rear corner. Some shims may be required for proper fit of the main frame to the tractor, see main frame mounting in the part section on this manual. With all sub-frame connections hardware in place, it should fit tightly and level under the tractor. Be sure to use a thread locking agent on all capscrews and nuts that attach the frame to the tractor.

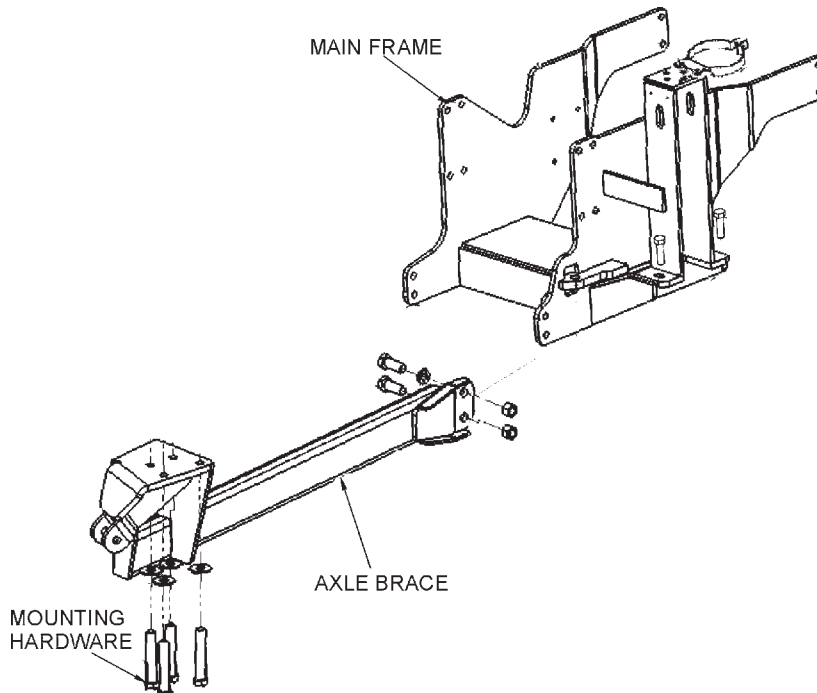

1146A MAIN FRAME MTG

ASSEMBLY

CABLE LIFT DRAFT BEAM INSTALLATION

Install ½" O-ring breather into butt port of inboard cylinder. In all fittings in the rod end of the cylinder according to diagrams in parts section. These fittings should be positioned to face the butt end of the cylinder.

Next turn the clevis onto the rod of the cylinder until it is tight against the shoulder and lock into place with locking bolt on clevis.

The inboard cylinder can now be installed into the main frame mast with the pin, flat-washers and R-clips as shown below.

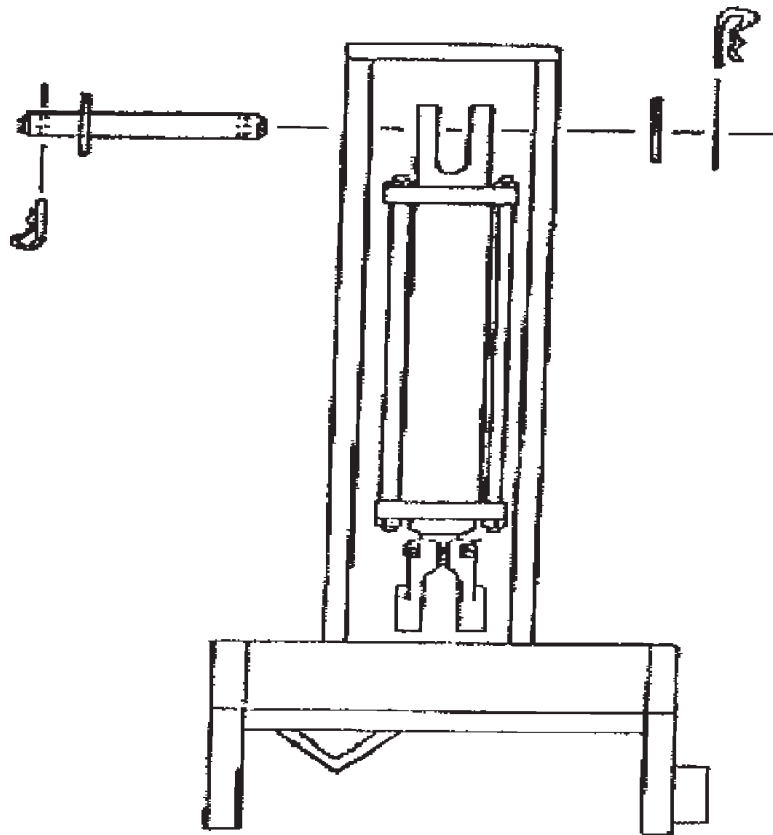

LIFT CONTROL FEEDLINES

Hose lengths will vary between tractor applications such as cab and non-cab units. See the parts section that pertains to your tractor for hose applications.

Install a hose from the bottom or inner valve port (in fender well for cab units, on stand for non-cab units) to the restrictor on the inboard cylinder gland.

Install a hose from the upper or outer valve port to the restrictor on the outboard cylinder butt. Use teflon tape on all fitting and hose connections.

ASSEMBLY

DRAFT BEAM MOUNTING

Pull the inboard cylinder piston rod down to the extreme extended position. Slide the draft beam under the cylinder, and align clevis hole with draft beam hole nearest to the tractor. Install pin and secure with R-clips.

Using inboard cylinder as a pivot point, slide draft beam under tractor and install draft beam pin. Align hole in draft beam pin with holes in main frame boss and install cap-screw, lock-washer and hex nut.

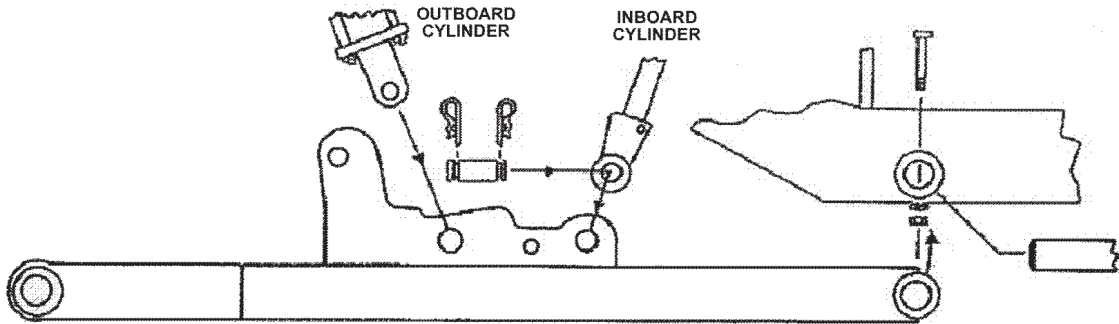

Install the fittings in the butt end of the outboard cylinder, as shown in the parts section. These should be positioned to face the rod end of the cylinder. Next, install the O-ring breather in the rod end of the cylinder.

Install the outboard cylinder in the hole in the draft beam as shown in the diagram on the previous page. Install the pin into the draft beam and cylinder and secure with R-clips.

DECK / MOTOR FEEDLINE

Install the hose with the 90 degree #20 flange on one end between the front side of the motor to the bottom of the solenoid valve. Secure to motor with #20 flange kit.

Install the #20 flange adapter block to the back side of the motor and install swivel fittings. Install the hose from the fittings on the back of the motor to the top of the solenoid valve. Install split hoses around hydraulic hoses where they contact the edge of the head, or any other edges that may rub hoses.

Be sure that all grease zerks are installed in the draft beam pin bosses. Grease all areas of the draft beam according to the instructions in the maintenance section.

Re-check all fittings for tightness and be sure teflon tape has been used at all connections.

Fill hydraulic tank with fluid as recommended in the maintenance section. **BE SURE TO OPEN THE BALL VALVES.** Start the tractor and operate the inboard cylinder through the entire stroke and the outboard cylinder through the bottom $\frac{3}{4}$ stroke repeatedly to clear the lines of air. **DO NOT run outboard cylinder out to full stroke until turnbuckle has been adjusted!**

Check for oil leaks at all fittings and connections using a piece of paper or cardboard. **DO NOT USE HANDS TO CHECK FOR FLUID LEAKS!**

Raise the tree point hitch and check the tractor internal hydraulics, fill to proper level if needed.

ASSEMBLY

TRAVEL LOCK MOUNTING

Install the travel lock bracket with pin and clip on the draft beam. Slide the draft beam and align the travel lock bracket hole with the mounting hole on the main frame. Install the capscrew, lockwasher and hex nut as shown in the picture.

Raise the deck/flail to its upright position (Deck ear touches to stop bolt as shown in the picture). Drill a 13/16" hole to the deck/flail ear through the draft beam as shown below. Insert the supplied pin and clip through the hole.

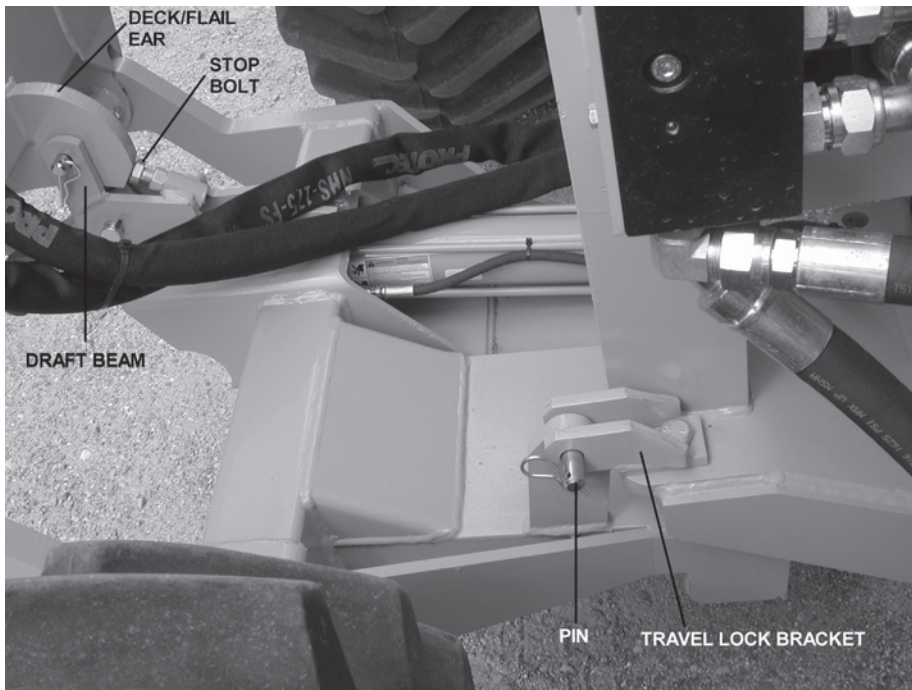

ASSEMBLY

DECK MOUNTING AND LIFT ASSEMBLY

Install the upper sheave bracket on the outboard cylinder and tighten securely against piston rod shoulder. Tighten the set screw, and align the draft beam.

Install the lower sheave bracket on the draft beam with a $\frac{3}{4}$ " cap-screw and two hex nuts as shown in the diagram on the next page.

Align the deck with the draft beam mounting hole and install the outer draft beam pin. Align the holes in the draft beam pin with the holes in the boss and secure with cap-screw, lock-washer and hex nut.

Pass the lift cable through upper sheave bracket and attach to turn buckle with turn buckle pin and cotter key. Attach turn buckle to draft beam with turn buckle pin and cotter key.

Place the cable in the upper sheave bracket with the cable on top of the wheel. Secure wheel with sheave pin (with grease zerk) and R-clip. Place lift cable in lower sheave below the wheel and install sheave with pin (with grease zerk) and R-clip. Then install the

The cable can now be attached to the deck mounting bracket with the shackle. Tighten shackle pin securely. **NOTE: DO NOT tighten the turn buckle at this time!**

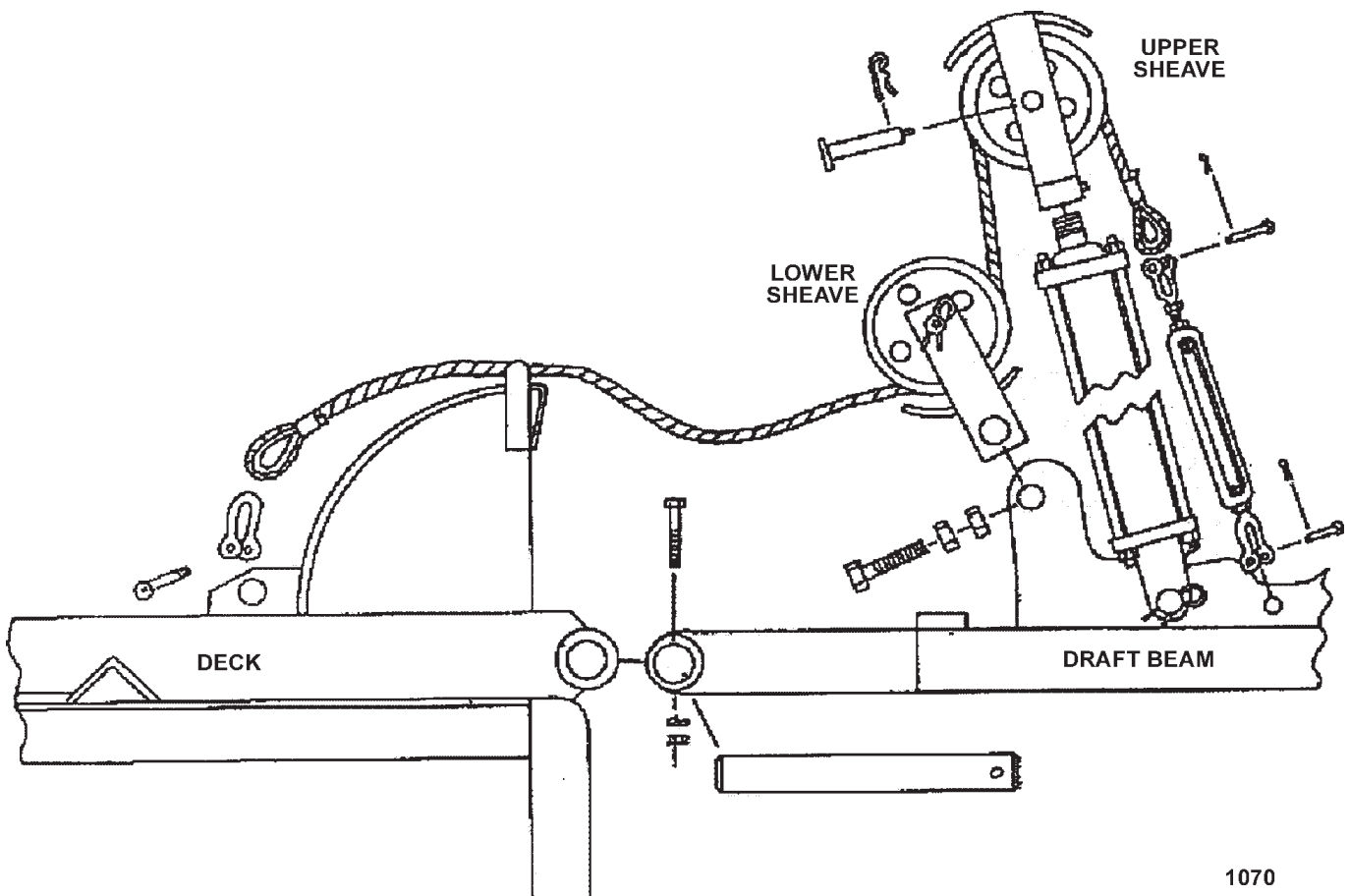

ASSEMBLY

TURNBUCKLE ADJUSTMENT

Extend the outboard cylinder until the deck touches the stop on the draft beam. Hold the deck in this position to adjust the lift cable tension. Adjust turn buckle until cable is tight.

Lower and raise the deck to check adjustment. The mower deck should reach it's stop on the draft beam at the same time the outboard cylinder reaches it's extreme extended position.

Finally tighten the turn buckle lock nuts securely. It will be necessary to readjust the turn buckle after the cable has stretched from use.

FINAL PREPARATION FOR OPERATION

Place operators safety and operation decals on the steering column and side counsel where they are clearly visible to the operator. These decals should be understood by each operator of the machine in conjunction with the safety and operation section of this book. The decals are to remain in good condition as a reminder to the operator, and should be replaced if damaged.

Double check that all pivot points have been greased. Secure all hoses together with zip ties and wrap with split hose sections where friction may occur on the hose.

WARNING!



BEFORE starting or operating the tractor you must read and understand the safety and operation sections of this manual completely.

Before operating the mower, the cutter head and draft beam should be slowly moved throughout the full range of motion. Watch for any condition that would cause pinching or excess stress on the hoses. The steering and front axle travel should also be carefully moved through their full range of motion. If any condition occurs in which the hoses contact the tires, the steering and / or front axle travel may need to be limited as described in the tractor operators manual. This should also be done if the tires rub, or are extremely close to any other part of the mower such as the hydraulic tank or draft beam. This may include adding shims, or adjusting stop bolts in the tractor front to solve the problem. While checking motion, you should also check that the control circuits are connected according to the operators decal for the valve handles.

MOWER TESTING

Take the tractor to a place free of loose objects on the ground. Operate the cylinders through their full range of motion again, to clear the lines of air. Follow the instructions in the operation section to operate the mower. Vibration of the mower should be minimal at all times. After a 5 minute test run, the knife bolts should be retorqued and once again after the first few hours of operation.

If any parts of this assembly section, or any other section of this manual are not clearly understood you must contact your dealer or the address on the front of this manual for assistance!

ASSEMBLY

COMBO LIFT DRAFT BEAM INSTALLATION

Install ½" O-ring breather into butt port of inboard cylinder. In all fittings in the rod end of the cylinder according to diagrams in parts section. These fittings should be positioned to face the butt end of the cylinder.

Next turn the clevis onto the rod of the cylinder until it is tight against the shoulder and lock into place with locking bolt on clevis.

The inboard cylinder can now be installed into the main frame mast with the pin, flat-washers and R-clips as shown below. Use teflon tape on all fitting and hose connections.

Install all fittings in the outboard cylinder and adjust to point towards the butt end of the cylinder. Attach the hoses as specified in the parts book. Slide the cylinder into the draft beam from the outside of the draft beam and attach cylinder to the draft beam with clevis pin and R-clips.

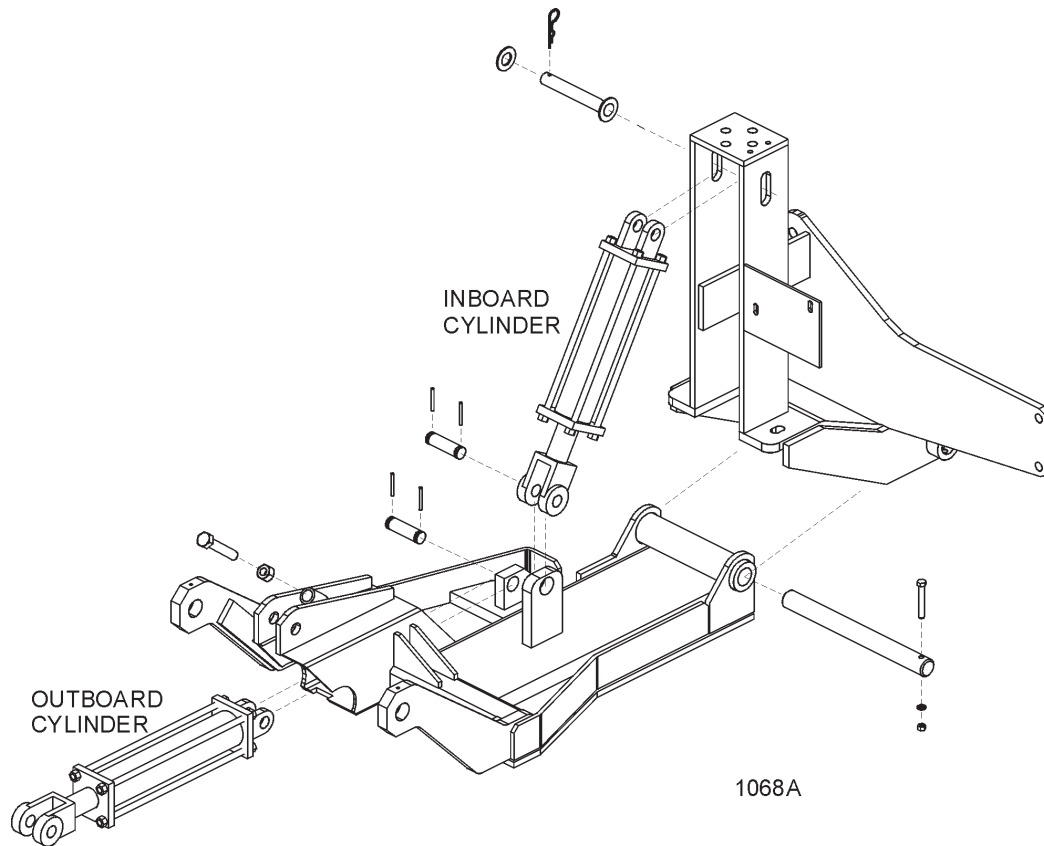

DRAFT BEAM MOUNTING

Pull the inboard cylinder piston rod down to the extreme extended position. Slide the draft beam under the cylinder, and align clevis hole with draft beam hole nearest to the tractor. Install pin and secure with R-clips.

Using inboard cylinder as a pivot point, slide draft beam under tractor and install draft beam pin. Align hole in draft beam pin with holes in main frame boss and install cap-screw, lock-washer and hex nut.

ASSEMBLY

DECK MOUNTING

Check that all grease zerks have been installed in the draft beams pivot arm, left linkage arm, right linkage arm, and cylinder mounting ears.

Using a clevis pin and roll pins, connect the pivot arm to clevis on draft beam.

NOTE: Make sure the longer distance between the cutout and the end of the pivot arm is closest to the draft beam pivot ears on the center tube as shown in the diagram below. Also make sure the cutout on the pivot arm faces into tube of draft beam.

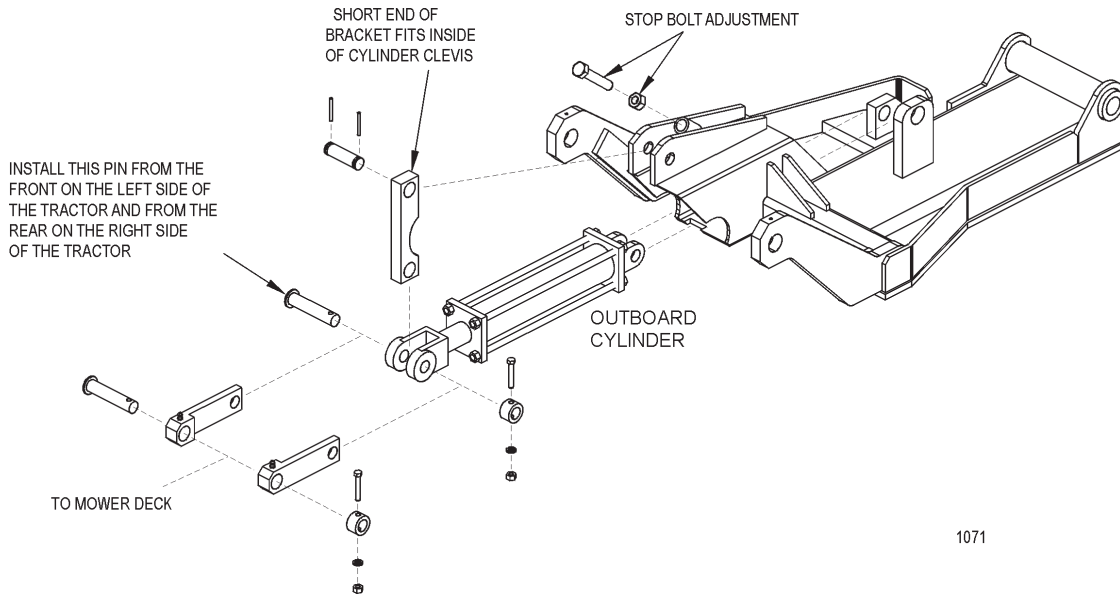

1071

Slide other end of pivot arm with short distance between the cut-out and the end of the pivot arm, into the cylinder clevis. Next, line up the holes of the left and right lift linkage arms outside of the cylinder clevis holes. Connect with linkage pin, shims (as required), boss, cap-screw, lock-washer and hex nut as shown.

To connect the bonnet to the draft beam, slide the extension arms of the draft beam between the mounting ears on the inner end of the bonnet. Line up the holes and secure with swivel pin, cap-screw, lock-washer, and hex nut (both sides). See parts book illustration.

Next, slide the left and right linkage arms up to the slotted ear on the side of the deck. Secure with linkage pin, shims, boss, cap-screw, lock-washer and hex nut. See illustration in parts section.

DECK / MOTOR FEEDLINE

Install the 1" hose with the 180 degree flange on the front side of the motor to the top of the solenoid valve. Secure to motor with flange kit, and install swivel fittings on the other end. Install the other 1" hose with the 60 degree flange on the back side of the motor to the bottom of the solenoid valve.

Install split hoses around hydraulic hoses where they contact sharp edges, or any other edges that may rub hoses.

ASSEMBLY

DECK / MOTOR FEEDLINE MOUNTING (cont.)

Be sure that all grease zerks are installed in the draft beam pin bosses. Grease all areas of the draft beam according to the instructions in the maintenance section. Re-check all fittings for tightness and be sure teflon tape has been used at all connections.

Fill hydraulic tank with fluid as recommended in the maintenance section. **BE SURE TO OPEN THE BALL VALVES.** Start the tractor and operate the inboard cylinder through the entire stroke and the outboard cylinder through the bottom $\frac{3}{4}$ stroke repeatedly to clear the lines of air. **DO NOT run outboard cylinder out to full stroke until stop bolt has been adjusted!**

Check for oil leaks at all fittings and connections using a piece of paper or cardboard. If a leak is found, you must shut down the tractor and set the cutter head on the ground. Before attempting to fix the leak, you must actuate the lift valve handles several times to relieve any pressure in the lines. **DO NOT USE HANDS TO CHECK FOR FLUID LEAKS!**

Raise the tree point hitch and check the tractor internal hydraulics, fill to proper level if needed.

STOP BOLT ADJUSTMENT

Extend the outboard cylinder all the way out. Adjust the stop adjustment bolt (located on the top of the draft beam) out until it is up against the bonnet. Lock the bolt down with the $\frac{3}{4}$ " hex nut.

NOTE: When the outboard cylinder is fully extended, the bonnet or deck should either be up against the stop or if travel locks are installed, it should be up against the travel lock. It may be necessary to use either external or internal slugs on the cylinder to get the correct stroke. If the cutter head is against the stop and the cylinder has stroke remaining, serious damage will occur.

Proceed to final preparation for operation instructions on the next page.

ASSEMBLY

FINAL PREPARATION FOR OPERATION

Place operators safety and operation decals on the steering column and side counsel where they are clearly visible to the operator. These decals should be understood by each operator of the machine in conjunction with the safety and operation section of this book. The decals are to remain in good condition as a reminder to the operator, and should be replaced if damaged.

Double check that all pivot points have been greased. Secure all hoses together with zip ties and wrap with split hose sections where friction may occur on the hose.

WARNING!



BEFORE starting or operating the tractor you must read and understand the safety and operation sections of this manual completely.

Before operating the mower, the cutter head and draft beam should be slowly moved throughout the full range of motion. Watch for any condition that would cause pinching or excess stress on the hoses. The steering and front axle travel should also be carefully moved through their full range of motion. If any condition occurs in which the hoses contact the tires, the steering and / or front axle travel may need to be limited as described in the tractor operators manual. This should also be done if the tires rub, or are extremely close to any other part of the mower such as the hydraulic tank or draft beam. This may include adding shims, or adjusting stop bolts in the tractor front to solve the problem. While checking motion, you should also check that the control circuits are connected according to the operators decal for the valve handles.

MOWER TESTING

Take the tractor to a place free of loose objects on the ground. Operate the cylinders through their full range of motion again, to clear the lines of air. Follow the instructions in the operation section to operate the mower. Vibration of the mower should be minimal at all times. After a 5 minute test run, the knife bolts should be retorqued and once again after the first few hours of operation.

If any parts of this assembly section, or any other section of this manual are not clearly understood you must contact your dealer or the address on the front of this manual for assistance!

OPERATION

**OPERATION
SECTION**

OPERATION

Safety is of primary importance to the owner / operator and to the manufacturer. The first section of this manual includes a list of Safety Messages, that, if followed, will help protect the operator and bystanders from injury or death. Many of the messages will be repeated throughout the manual. The owner / operator / dealer should know these Safety Messages before assembly and be aware of the hazards of operating this mower during assembly, use, and maintenance.

The **Safety Alert Symbol** combined with a signal word, as seen below, is intended to warn the owner / operator of impending hazards and the degree of injury possible during operation.

DANGER!



Indicates an imminently hazardous situation that, if not avoided, WILL result in DEATH OR VERY SERIOUS INJURY.

WARNING!



Indicates an imminently hazardous situation that, if not avoided, COULD result in DEATH OR SERIOUS INJURY.

CAUTION!



Indicates an imminently hazardous situation that, if not avoided, MAY result in MINOR INJURY.

IMPORTANT!

Identifies special instructions or procedures that, if not strictly observed, could result in damage to, or destruction of the machine, attachments or the environment.

NOTE: *Identifies points of particular interest for more efficient or convenient operation or repair.* (SG-1)

CAUTION!



Before any operation of tractor and mower, the user should read and understand the safety and operating instructions for both the tractor and the mower. The user should also be familiar with the location and functions of the units instruments and controls. Being familiar with the machine and its controls will increase efficiency and reduce possibility of serious injury or damage to the unit. The operator should work slowly and carefully until he feels comfortable with the machine. Speed and skill will be attained much easier if the necessary time is spent to familiarize yourself with the machine and its operations.

Since tractor makes and models vary, we recommend reading and following the operators manual provided by the manufacturer pertaining to your particular unit.

OPERATION



STARTING TRACTOR AND MOWER



Check the operators manual received from the tractor manufacturer, for their recommendation and procedures pertaining to your particular make and model.

WARNING!



When rotating parts are in motion, serious injury may occur if caution is not used or danger is not recognized. Never allow bystanders within **300 feet** of the machine when mower is in operation.



Be sure the ball valves on the mower hydraulic tank are **OPEN** before starting the tractor. Serious damage to the hydraulic system can occur if the valves are not open.

WARNING!



Check to make sure mower switch is in the “**OFF**” position. The unit is designed not to start if the switch is in the “on” position. If tractor starts with switch on, turn off tractor and contact your local Tiger dealership for assistance.

Start the tractor and allow the instruments to stabilize. Without starting the mower, practice positioning the boom and deck. Remember, speed and skill will be attained easier if the necessary time is spent familiarizing yourself with the machine and its operations. When you feel comfortable at controlling the position of the mower, return the mower to the travel position, and transport the mower to the desired mowing location.

If mowing for the first time with a Tiger Boom Mower, we recommend choosing a ditch or area relatively flat with a minimum of sign posts, guard rails, etc. As always, you should inspect the area for other objects that can cause potential hazards.

The Mower Control switch turns the mower “ON” and “OFF”. This switch is to be in the “OFF” position to start the tractor. The tractor will not start with the switch in the “ON” position.

WARNING!



If tractor starts with switch on, turn off tractor and contact your local Tiger dealership for assistance.

CONTROL LOCATION AND FUNCTIONS

The side mower height is controlled with a two or three spool valve and is coordinated as shown below. The optional three spool valve allows for the operation of a rear rotary mower or side ditcher. If the unit is equipped with a three spool valve, do not operate the third spool handle unless a rear rotary or ditcher is mounted.

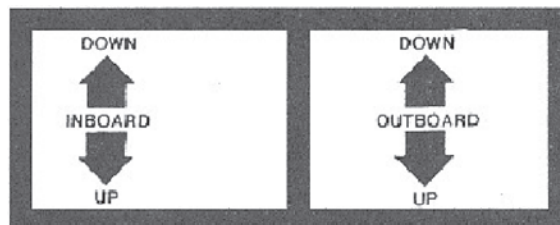

OPERATION

The rear mower height is controlled with the 3-point hitch control lever. Follow the instructions for this control in the tractor operators manual. The tilt of the rear mower is controlled with the third spool if the lift valve and is coordinated as shown above.

The side and rear mower positions may optionally be controlled with the tractors remote hydraulic connections or a combination of lift valve and remote hydraulics. If so, determine which position of the side or rear mower is to be controlled by each remote lever.

The side mower ON / OFF switch is located in a switch box mounted to the valve stand or cable controls for non-cab and cab units respectively. If operating a rear mower, the ON / OFF switch is located in the switch box with a side mower switch.

This machine may be equipped with an auxiliary oil temperature gauge, an amp gauge or oil pressure gauge. If oil temperature reaches 200 degrees Fahrenheit, stop mowers and see trouble shooting section for possible causes. Keep an eye on all gauges for indication of problems.

MOWER OPERATION

WARNING!



When rotating parts are in motion, serious injury may occur if caution is not used or danger is not recognized. Never allow bystanders within **300 feet** of the machine when in operation. Extreme care should be taken when operating near loose objects – such as gravel, rocks and debris. These conditions should be avoided.

The rotating parts in this machine have been designed and tested for rugged use. However, they could fail upon impact with heavy solid objects – such as steel guard rails, concrete abutments, etc., causing them to be thrown at a very high velocity. Never allow cutter head to contact such objects. Inspecting the cutting area for such objects prior to mowing can help eliminate these potential hazards.

Once on location, lower the mower deck slightly above the material to be cut, so the mower does not have to start under a load. Bring the R.P.M. of the tractor up to 1200 and engage the side mower. If a rear mower is being used, allow the R.P.M. to return to 1200 before engaging the rear mower.

The flail mower deck should be carried so that part of the weight is carried by the ground roller. When the flail is carried this way, the roller also follows the contour of the ground more easily during mowing operations.

When cutting small shrubs or brush, begin each pass at the top of the material and work down with each consecutive pass. Use a low speed to allow the cutting blades time to mulch as well as cut the foliage. When the initial pass has been made, disengage the mower and return the mower to the travel position. Return to the starting point and make next pass, etc. The flail head is not intended for cutting heavy brush, or for continually cutting brush. Wear or damage of the blades will occur rapidly when the flail cutter is used this way.

OPERATION

To ensure a clean cut, engine speed should be maintained at approximately 1800 – 2200 R.P.M. If the tractor slows to less than 1800 R.P.M., shift to the next lower gear. **DO NOT** ride the clutch, this will cause premature clutch failure. **The engine should not be operated at any time at more than 2400 R.P.M. on the tractor tachometer.**

The mower will operate more efficiently in tougher conditions and with less power if the knives are kept sharp. If the mower begins to vibrate, stop the tractor, check for wire wrapped in the spindle or damaged knives. When replacing knives, replace all knives with new knives to ensure proper balance so the mower will not vibrate. Severe vibration will result, if knives with unequal wear are used. Follow the instructions in the maintenance section closely when replacing knife blades.

WARNING!



If bystanders approach within 300 feet while mower is in operation turn mower switch “OFF” immediately! After shutdown, never leave the tractor or allow bystanders to approach within **300 FEET** of the unit until all motion stops completely.

When encountering a very severe condition which causes the tractor to stall, disengage mower, start tractor, raise the mower from the cut. Shut tractor off and inspect the mower, blades and disk for damage before engaging mower again.

If the blades jam or stop, disengage the clutch and raise the head slightly or back the tractor up. Normally, this will clear the cutter head. If not, shut off the mower(s), raise the cutter heads, turn off the tractor and set the parking brake. After all motion stops completely, leave the tractor and clear the cutting heads manually.

After the first day of operation, all bolts should be checked and tightened securely.

This should be done periodically to ensure the bolts do not become loose and cause damage to the tractor or mower, or injury to the operator.

OPERATION

TRANSPORTING MOWER

Transporting under the units own power:

When transporting between job sites or between cutting passes, the following procedure should be followed: Shut off the power to the cutting head(s) and allow all motion to come to a complete stop. Raise the draft beam to it's highest position. Raise the side mower until the deck stops against the draft beam. Raise the rear mower with the 3-point hitch control lever. The unit is now in position for self transportation.

Transporting unit by flatbed trailer:

Most tractors with a side mounted mower head attached will be over legal transporting width (102" wide). For this reason, one of the following procedures must be followed.

1: Transporting with side mower attached: Use a loading dock or ramp to load tractor onto the trailer. Center the tractor with the mowers attached between the sides of the trailer. Make sure the draft beam and head are fully raised and secured. Lower the rear mower onto the trailer. Secure the tractor and rear mower to the trailer with chains. Obtain proper over-width permits and mark the vehicle and mower as over-width as required be law. Check the tractor operators manual for any tractor requirements to transport by flatbed trailer.

2: Transporting with side mower removed: Park the tractor and turn the engine off. Remove the key to avoid accidental starting. Close ball valves on the hydraulic reservoir. To avoid contaminating the hydraulic system, make sure all fittings on the side mower motor and solenoid control valve are clean. Disconnect the motor pressure hose at the solenoid valve and the motor return hose at the motor. See diagram below.

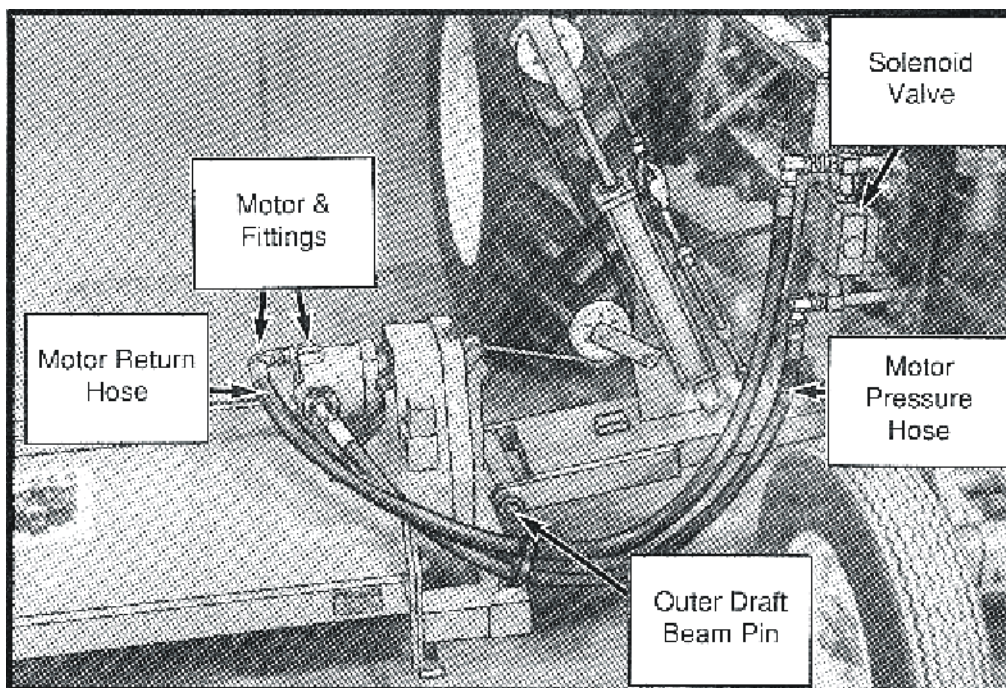

OPERATION

Next, switch the hose ends and reconnect to form two separate closed loops, see diagram below. Disconnect the lift cable from the head and secure the loose end back onto the cable with the cable clevis. Remove the keeper bolt and draft beam outer pivot pin. Separate the mower head from the tractor. Now reinstall the pivot pin and keeper bolts into the draft beam to prevent loss. **OPEN THE BALL VALVES ON THE HYDRAULIC RESERVOIR BEFORE STARTING TRACTOR AGAIN!** Serious damage will be caused if tractor is started with the ball valves closed.

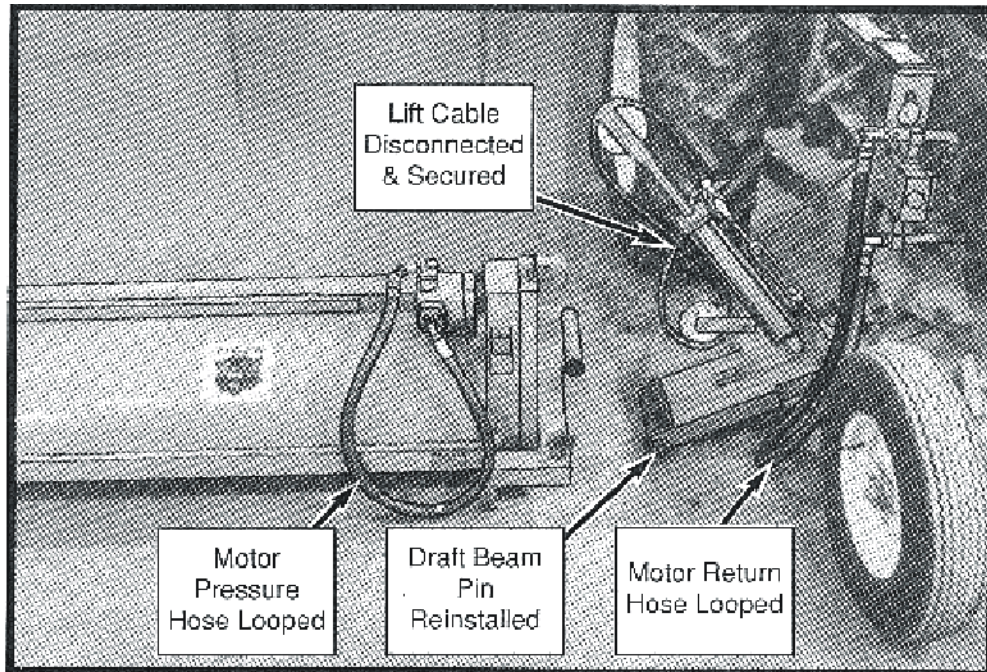

Use a loading dock or ramps to load the tractor onto the trailer, centering the tractor between the sides of the trailer. Make sure the tractor (and rear mower) and trailer are within legal transporting width. Lower the rear mower onto the trailer and set the loose hide mower on the trailer. Secure the tractor and mowers to the trailer with chains. Check the tractor operators manual for any requirements to transport be flatbed trailer. Reverse this procedure to unload and remount the mowers after transporting. Be sure all pins are secure, all connections are tight and any lost fluid is replaced before using mowers. Use teflon tape when connecting all fittings.

CAUTION!



If any part of this operating section, or any other section of this manual is not completely understood, contact your Tiger dealer or the address on the cover of this manual for assistance!

OPERATION

11.6 Setting Reverse Rotation

When you set up the flail mower so that the cutter shaft is rotating in the reverse rotation (opposite direction of the tractor tire rolling forward), you will need to do the following;

First, start by removing the PTO Shaft(1) and PTO Shield(2), bolts(3), lockwasher & flatwasher(4).

Then remove the four bolts(5) and lockwashers(6) attaching the output shaft guard(7).

Remove the four bolts(8) and lockwashers (9) attaching the gearbox (10) to the flail driveline(11).

Next remove the four gearbox bolts(12) and lockwashers(13) from mounting plate(14).

Once Gearbox is loose, slide it out of flail driveline(11). Rotate gearbox 180° to the right until the reverse rotation input shaft(15) is aligned in the position that the normal rotation input shaft(16) originally was. Grab the gearbox from the end of the bearing housing output shaft(17) and flip the entire gearbox to the left.

Align the bearing housing output shaft(17) with the flail driveline(11) and make sure that the output shaft is set correctly with the spline coupling inside the shaft guard.

Once aligned, loosely reattach flail driveline bolts(8) and lockwashers(9). Do not tighten at this time.

Attach the gearbox bolts(12) and lockwashers(13) to the mounting plate(14), and tighten.

Once gearbox is tightened go back to the flail driveline and tighten bolts and lockwashers.

Next, attach the input shaft guard to the normal rotation input shaft.

Then reattach the PTO Shield and PTO Shaft to gearbox.

Finally, remove front rubber guard and attach the Reverse Rotation Front Guard to flail.



Do not operate mower when the cutter shaft is in reverse rotation unless:

- Reverse Rotation Front Guard is in place, and
- The guard is in good working condition.

All safety devices should be inspected carefully at least daily for missing or broken components. Missing, broken, or worn items must be replaced at once to reduce the possibility of injury or death from thrown objects, entanglement, or blade contact. (SFL-8)

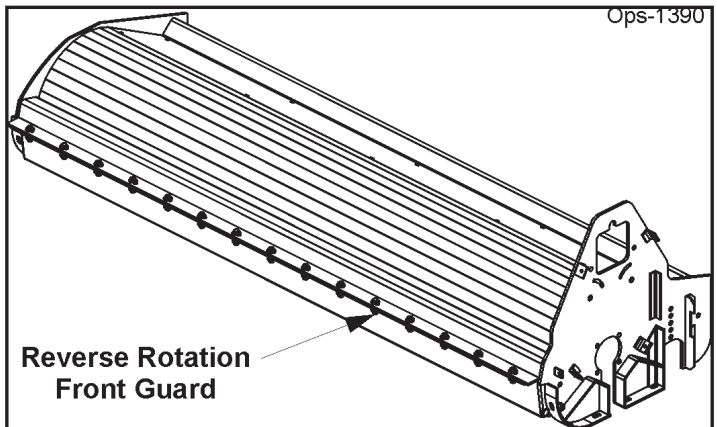
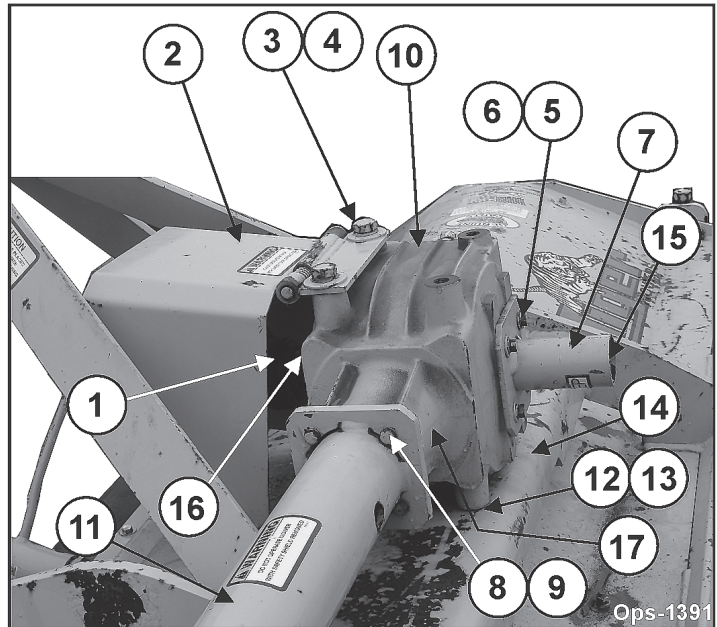

OPERATION INSPECTION SHEETS

Flail Mower PRE-OPERATION Inspection



Tractor ID# _____ Make _____

Date: _____ Shift _____

WARNING!



Before conducting the inspection, make sure the Tractor engine is off, all rotation has stop and the tractor is in the Park with the parking brake engaged. The Mower head is resting on the ground (or is securely blocked up and supported) and all hydraulic pressure has been relieved.

Item	Condition at Start of Shift	Specific Comments if not O.K.
The Operator's Manual is in the Canister on the mower		
All Safety Decals are in place and legible		
The Hitch connection bolts & pins are tight		
There are no cracks in Hitch		
There mower deck is clear of cut grass and debris		
The Thrown object Guards/Deflectors are in place		
There Guards/Deflectors are in good condition		
The Driveline/Gearbox shields are in good condition		
The Driveline clutch is in good condition, not frozen		
The driveline tubes & u-joints have been lubricated		
The Driveline yoke is securely attached to the PTO		
The Gearbox oil level is full		
Blades are not broken, chipped, cracked or bent		
Blade shackles are in good condition with no cracks		
The Blade pins are properly retained		
The Skid shoes are in good condition & tight		
The Rear Roller is in good condition and turns freely		

Operators Signature: _____

DO NOT OPERATE an UNSAFE TRACTOR or MOWER

OPERATION

TRACTOR PRE-OPERATION Inspection



Tractor ID# _____ Make _____

Date: _____ Shift _____

WARNING!



Before conducting the inspection, make sure the Tractor engine is off, all rotation has stop and the tractor is in the Park with the parking brake engaged. The Mower head is resting on the ground (or is securely blocked up and supported) and all hydraulic pressure has been relieved.

Item	Condition at Start of Shift	Specific Comments if not O.K.
The Flashing lights function properly		
The SMV Sign is clean and visible		
The Tires are in good condition with proper pressure		
The Wheel Lug bolts are tight		
The tractor Brakes are in good condition		
The Steering linkage is in good condition		
There are no visible Oil Leaks		
The Hydraulic controls function properly		
The ROPS or ROPS Cab is in good condition		
The Seatbelt is in place and in good condition		
The 3-Point Hitch is in good condition		
The Drawbar pins are securely in place		
The PTO Master Shield is in place		
The Engine Oil level is full		
The Brake Fluid level is full		
The Power Steering Fluid Level is full		
The Fuel level is adequate		
The Engine Coolant Fluid level is full		
The Radiator is free of debris		
The Air filter is in good condition		

Operators Signature: _____

DO NOT OPERATE an UNSAFE TRACTOR or MOWER

OPERATION

FRONT END LOADER PRE-OPERATION Inspection



Mower ID# _____ Make _____

Date: _____ Shift _____

WARNING!



Before conducting the inspection, make sure the Tractor engine is off, all rotation has stop and the tractor is in the Park with the parking brake engaged. The Loader is resting on the ground (or is securely blocked up and supported) and all hydraulic pressure has been relieved.

Item	Condition at Start of Shift	Specific Comments if not O.K.
The Operator's Manual is in the Canister on the mower		
All Safety Decals are in place and legible		
The Mounting frame bolts are in place and tight		
There are no cracks in Draftbeam or Yolk		
The Draftbeam/Yolk connection bolts & pins are tight		
There are no cracks or holes in mower deck		
The Hydraulic motor mounting bolts are tight		
The mower head spindle housing is tight and lubricated		
There mower deck is clear of cut grass and debris		
The Skid shoes are in good condition & tight		
Chain Guards/Deflectors are in place & in good condition		
Blade carrier retaining nut is tight		
Blades are not chipped, cracked or bent		
Blade bolts are tight		
Transport locks are in good condition		
There are no leaking or damaged hoses		
There is no evidence of Hydraulic leaks		
The Hydraulic Oil level is full		
The Hydraulic Cylinders pins are tight		
The Hydraulic Pump hose connections are tight		
The Hydraulic Valve hose connections are tight		
The Hydraulic Valve controls function properly		
Wheel lug nuts are tight		

Operators Signature: _____

DO NOT OPERATE an UNSAFE TRACTOR or FRONT END LOADER

OPERATION

TRACTOR PRE-OPERATION Inspection



Tractor ID# _____ Make _____

Date: _____ Shift _____

WARNING!



Before conducting the inspection, make sure the Tractor engine is off, all rotation has stop and the tractor is in the Park with the parking brake engaged. The Loader is resting on the ground (or is securely blocked up and supported) and all hydraulic pressure has been relieved.

Item	Condition at Start of Shift	Specific Comments if not O.K.
The Flashing lights function properly		
The SMV Sign is clean and visible		
The Tires are in good condition with proper pressure		
The Wheel Lug bolts are tight		
The Tractor Brakes are in good condition		
The Steering linkage is in good condition		
There are no visible Oil Leaks		
The Hydraulic controls function properly		
The ROPS or ROPS Cab is in good condition		
The Seatbelt is in place and in good condition		
The PTO Master Shield is in place		
The Engine Oil level is full		
The Brake Fluid level is full		
The Power Steering Fluid Level is full		
The Fuel level is adequate		
The Engine Coolant Fluid level is full		
The Radiator is free of debris		
The Air filter is in good condition		

Operators Signature: _____

**DO NOT OPERATE an UNSAFE TRACTOR or FRONT END
LOADER**

MAINTENANCE

MAINTENANCE SECTION

MAINTENANCE

Tiger Mowers are designed for high performance and rugged durability, yet with simplified maintenance. The purpose of this section of the manual is to help the operator in the regular servicing of the mower. Regular maintenance at the intervals mentioned will result in the maximum efficiency and long life of the Tiger Mower.

When you purchase a Tiger Mower you also acquire another valuable asset, Tiger's parts organization. Our rapid and efficient service has guaranteed the customer satisfaction for many years. Tiger parts keep up with the demands for efficiency, safety and endurance expected of the Tiger Mower.

MAINTENANCE PRECAUTIONS

- Be sure end of grease gun and zerks are clean before using. Debris injected into bearings, etc. with grease will cause immediate damage.
- DO NOT use a power grease gun to lubricate bearings. These require very small and exact amounts of lubrication. Refer to the detailed maintenance section for specific lubrication instructions. Do Not over-grease bearings.
- Lexan windows should be washed with mild soap or detergent and luke warm water, using a soft clean sponge or **soft cloth**. DO NOT use abrasive or alkaline cleaners or metal scrapers on lexan windows!
- Be alert to maintenance indicators such as the in-tank filter pressure gauge, hydraulic reservoir sight gauge, etc. Take the required action to correct any problems immediately.
- Release of energy from pressurized systems may cause inadvertent actuation of cylinders, or sudden release of compressed springs. Before disconnecting any hoses relieve pressure by shutting tractor off, setting cutter on ground and actuating lift valve handles.

WARNING!



DO NOT use hands to check for suspected leaks in hydraulic hoses! Hydraulic fluid escaping under pressure can have sufficient force to penetrate skin and cause serious injury. If fluid is injected into skin, it must be surgically removed within a few hours or gangrene may result. Use a small piece of wood or cardboard, not hands, to search for pin hose leaks. Be sure all pressure is relieved whenever disconnecting lines. Be sure all connections are tight and hoses and lines are not damaged before applying pressure.

BREAK IN PERIOD

In addition to following the break in instructions for your particular tractor, the in-tank hydraulic fluid filter should be replaced after the first 50 hours of service. Thereafter the filter should be replaced every 500 hours, or yearly, which ever comes first.

Re-torque wheel lugs after first five hours of operation and periodically thereafter. See torque specifications listed in the tractor's service manual for your particular model. **Wheel lugs must always be re-torqued whenever a wheel is removed and reinstalled.**

MAINTENANCE

REGULAR MAINTENANCE

The intervals at which regular servicing should be done are based on hours of operation. Use the tractors hour meter to determine when regular servicing is required.



This symbol indicates a point that needs to be greased at an interval noted in the section below. Refer to the Detailed Maintenance section for further instructions on greasing. Copy and use the Daily Maintenance sheet located at the end of this section.

DAILY OR EVERY 8 HOURS

ITEM	SERVICE	COMMENTS
Drive Shaft Yoke, U-Joint & Stub Shaft	Grease	Grease as instructed in detailed maint. section
Pump Drive Shaft	Check and Lube	Insure drive shaft end play
Crankshaft Adapter	Check rubber grommets	Replace grommets if damaged or missing
Pivot Points	Lubricate	Inject grease until it appears at ends
Hydraulic Fittings	Check for leaks	Tighten when needed. Do Not use hands to check for leaks, see maint. Precautions
Knives	Check	Inspect for missing or damaged knives, change or sharpen as needed
Cutter shaft mounting bolts (cutter shaft to deck)	Check	1/2" x 2" torque to 84 ft. lbs.
Knife mounting bolts (knife to cutter shaft)	Check	Retorque to knife replacement specifications
Belts	Check / Adjust	Check if broken, tighten as required
Main Frame and Deck	Check	Retorque bolts to torque specifications in this section
Hydraulic Fluid Level	Check	Add if required per fluid recommendations
Rear Flail Drive (if applicable) Bearing Flange and Shaft Coupler	Lubricate	Grease as instructed in detailed maint. section
Cutter Shaft and Ground Roller	Lubricate	Grease as instructed in detailed maint. section

MAINTENANCE

WEEKLY OR EVERY 50 HOURS

ITEM	SERVICE	COMMENTS
In Tank Hyd. Fluid Filter (10 micron filter)	Change	Change after first 50 hours only, then every 500 hours or yearly
In-Line High Pressure Filter (10 micron filter)	Change	Change after first 50 hours only, then every 500 hours or yearly

MONTHLY OR EVERY 150 HOURS

Hydraulic Fluid Level	Check	Add as needed
Hyd. Tank Breather	Clean / Check / Replace	Clean or replace Element as required

Rear Tire Type	Max P.S.I.
480/80R38	29
18.4-34	26
18.4-38	26

YEARLY OR EVERY 500 HOURS

Hyd. Tank Fluid	Change	
In Tank Hyd. Fluid Filter (10 micron filter)	Change	
In-Line High Pressure Filter (10 micron filter)	Change	or Change when indicated by restriction indicator.
Hyd. Tank Breather	Change	

TROUBLE SHOOTING

SYMPTOMS	CAUSE	REMEDY
Vibration	1. Loose bolts	1. Check all bolts and tighten to torque specs. in this section.
	2. Cutter assembly Unbalanced	2a. Check for damaged blades, disc. or cutter shaft. Replace if needed. 2b. Check for wire, rope, etc. entangled in cutter assembly
Mower will not lift	1. Hyd. Fluid low	1. Check and refill Hyd. Fluid
	2. Leaks in line	2. Tighten or replace fittings and hoses
	3. Faulty relief valve in Control Valve	3. Check pressure in line. Line pressure should be at least 2500 PSI
	4. Kinked or blocked	4. Clean or replace lines
	5. Faulty cylinder	5. Inspect, repair or replace cylinder

MAINTENANCE

SYMPTOMS	CAUSE	REMEDY
Mower will not start or run	<ol style="list-style-type: none"> 1. Blown fuse 2. Ball valves closed 3. Low oil level 4. Line leak 	<ol style="list-style-type: none"> 1. Check fuse between mower switch and ignition / replace 2. Make sure valves are open 3. Check Hyd. tank and fill 4. Check all fittings and lines, re-tighten or replace.
Oil Temperature rises above 200 deg. F	<ol style="list-style-type: none"> 1. Low oil level 2. Kinked or blocked 3. Worn pump/motor 	<ol style="list-style-type: none"> 1. Bring oil to proper level 2. Inspect, Repair, or Replace hoses 3. Disable and repair
Mower will not start or run, cont.	<ol style="list-style-type: none"> 1. Electronic solenoid faulty 	<ol style="list-style-type: none"> 1a. Without the tractor running, turn the mower switch to on. A low audible click should be heard if the solenoid is engaging the solenoid spool. If click is not heard, leave switch in on position and with a screwdriver or other steel object, touch the small nut on the end of the solenoid. If the metallic object is not attracted to the nut, check the fuse and wiring for an open circuit. If the object is attracted but no "click" is heard, replace the solenoid. 1b. Remove the four bolts holding the small block to the main block. Lift and remove small block being careful not to damage O-rings / filter. Clean filter and re-install. 1c. Remove large nut on side of large valve block. Remove spring, and use needle nose vise grip to pull spool from block. Check block and spool for contaminates and scratches. Clean parts or replace if scratched.
Motor runs but will not cut.	<ol style="list-style-type: none"> 1. Belts 2. Tensioner 	<ol style="list-style-type: none"> 1. Inspect belts and pulleys. Replace belts and repair as needed. 2. Adjust tensioner nut until flat washer washer is flush with top of guide.
Motor turns slowly or not at all.	<ol style="list-style-type: none"> 1. Contaminants restricting spool movement in valve body. 2. Suction lines obstructed 3. Low oil level 	<ol style="list-style-type: none"> 1. Remove large nut on side of large valve block. Remove spring, and use needle nose vise grip to pull spool from block. Check block and spool for contaminates and scratches. Clean parts or replace if scratched. 2. Check for crimp or obstruction in suction hose 3. Check Hyd. tank level and fill
Pump will not work	<ol style="list-style-type: none"> 1. Excessive wear on internal parts 	<ol style="list-style-type: none"> 1. Disassemble and repair.

MAINTENANCE

Motor will not work 1. Excessive wear on internal parts 1. Disassemble and repair.

NOTE: If flow meter is available, check pressure and flow volume for all suspected hydraulic problems.

If the solution to your problem cannot be found in this section, call the Technical Service representative at the number shown on the front cover of this manual.

MAINTENANCE

TORQUE SPECIFICATIONS

Torque for Standard Fasteners													
Nominal Dia. (in.)	threads per inch	Grade 2			Grade 5			Grade 8			Grade 9		
		Tightening Torque			Tightening Torque			Tightening Torque			Tightening Torque		
		Lubed	Dry Plated	Dry plain	Lubed	Dry Plated	Dry plain	Lubed	Dry Plated	Dry plain	Lubed	Dry Plated	Dry plain
		K = 0.15	K = 0.17	K = 0.20	K = 0.15	K = 0.17	K = 0.20	K = 0.15	K = 0.17	K = 0.20	K = 0.15	K = 0.17	K = 0.20
Unified Coarse Thread Series													
1/4	20	49 in-lbs	59 in-lbs	66 in-lbs	76 in-lbs	86 in-lbs	101 in-lbs	107 in-lbs	122 in-lbs	143 in-lbs	126 in-lbs	143 in-lbs	168 in-lbs
5/16	18	101	122	135	157	178	209	221	251	295	259	294	346
3/8	16	15 ft-lbs	18 ft-lbs	20 ft-lbs	23 ft-lbs	26 ft-lbs	31 ft-lbs	33 ft-lbs	37 ft-lbs	44 ft-lbs	38 ft-lbs	43 ft-lbs	51 ft-lbs
7/16	14	24	29	32	37	42	49	52	59	70	61	70	82
1/2	13	37	44	49	57	64	75	80	90	106	94	106	125
9/16	12	53	63	70	82	92	109	115	130	154	135	153	180
5/8	11	73	87	97	113	128	150	159	180	212	186	211	248
3/4	10	129	155	172	200	227	267	282	320	376	331	375	441
7/8	9	125	150	167	322	365	429	455	515	606	533	604	710
1	8	187	225	250	483	547	644	681	772	909	799	905	1065
1 1/8	7	266	319	354	596	675	794	966	1095	1288	1132	1283	1510
1 1/4	7	375	450	500	840	952	1121	1363	1545	1817	1597	1810	2130
1 1/2	6	652	783	869	1462	1657	1950	2371	2688	3162	2779	3150	3706
Fine Thread Series													
1/4	28	56 in-lbs	68 in-lbs	75 in-lbs	87 in-lbs	99 in-lbs	116 in-lbs	123 in-lbs	139 in-lbs	164 in-lbs	144 in-lbs	163 in-lbs	192 in-lbs
5/16	24	112	135	150	174	197	231	245	278	327	287	325	383
3/8	24	17 ft-lbs	20 ft-lbs	23 ft-lbs	26 ft-lbs	30 ft-lbs	35 ft-lbs	37 ft-lbs	42 ft-lbs	49 ft-lbs	43 ft-lbs	49 ft-lbs	58 ft-lbs
7/16	20	27	32	36	41	47	55	58	66	78	68	78	91
1/2	20	41	49	55	64	72	85	90	102	120	105	120	141
9/16	18	59	71	78	91	103	121	128	146	171	151	171	201
5/8	18	82	99	110	127	144	170	180	204	240	211	239	281
3/4	16	144	173	192	223	253	297	315	357	420	369	418	492
7/8	14	138	165	184	355	403	474	502	568	669	588	666	784
1	14	210	252	280	542	614	722	765	867	1020	896	1016	1195
1 1/8	12	298	357	397	668	757	890	1083	1227	1444	1269	1439	1693
1 1/4	12	415	498	553	930	1055	1241	1509	1710	2012	1768	2004	2358
1 1/2	12	734	880	978	1645	1865	2194	2668	3024	3557	3127	3544	4169

Torque values for 1/4 and 5/16-in series are in inch-pounds. All other torque values are in foot-pounds. K = 0.15 for "lubricated" conditions D = Nominal Diameter
 Torque values calculated from formula T=KDF, where K = 0.17 for zinc plated and dry conditions F = Clamp Load
 K = 0.20 for plain and dry conditions

Torque-Tension Relationship for Metric Fasteners													
Nominal Dia. (mm)	Pitch	Class 4.6			Class 8.8			Class 10.9			Class 12.9		
		Tightening Torque			Tightening Torque			Tightening Torque			Tightening Torque		
		Lubed	Dry Plated	Dry plain	Lubed	Dry Plated	Dry plain	Lubed	Dry Plated	Dry plain	Lubed	Dry Plated	Dry plain
		K = 0.15	K = 0.17	K = 0.20	K = 0.15	K = 0.17	K = 0.20	K = 0.15	K = 0.17	K = 0.20	K = 0.15	K = 0.20	
		(ft-lbs)	(ft-lbs)	(ft-lbs)	(ft-lbs)	(ft-lbs)	(ft-lbs)	(ft-lbs)	(ft-lbs)	(ft-lbs)	(ft-lbs)	(ft-lbs)	
3	0.5	0.28	0.32	0.38	0.73	0.82	0.97	1.0	1.2	1.4	1.2	1.6	
3.5	0.6	0.44	0.50	0.59	1.1	1.3	1.5	1.6	1.9	2.2	1.9	2.5	
4	0.7	0.66	0.74	0.87	1.7	1.9	2.3	2.4	2.7	3.2	2.8	3.8	
5	0.8	1.3	1.5	1.8	3.4	3.9	4.5	4.9	5.5	6.5	5.7	7.6	
6	1	2.3	2.6	3.0	5.8	6.6	7.7	8.3	9.4	11	9.7	13	
6	1.25	2.1	2.3	2.7	5.3	6.0	7.0	7.6	8.6	10	8.8	12	
7	1	3.8	4.3	5.0	9.7	11	13	14	16	19	16	22	
8	1	5.9	6.6	7.8	15	17	20	22	24	29	25	34	
8	1.25	5.5	6.2	7.3	14	16	19	20	23	27	24	31	
10	1.25	11	13	15	29	33	39	42	48	56	49	66	
10	1.5	11	12	14	28	32	37	40	45	53	47	62	
12	1.25	21	23	28	53	60	71	76	86	101	89	119	
12	1.5	20	22	26	51	58	68	73	82	97	85	113	
12	1.75	19	21	25	49	55	65	70	79	93	81	108	
14	1.25	26	29	34	66	75	89	95	108	127	111	148	
14	1.5	28	32	37	72	82	96	103	117	138	121	161	
14	2	30	34	40	78	88	104	111	126	148	130	173	
16	1.5	50	57	67	129	146	171	184	208	245	215	287	
16	2	47	53	62	121	137	161	173	196	230	202	269	
18	1.5	73	82	97	187	212	249	268	303	357	313	417	
18	2.5	65	73	86	167	189	222	239	270	318	279	372	
20	2.5	91	104	122	236	267	314	337	382	449	394	525	

Clamp load calculated as 75% of the proof load for specified bolts. K = 0.15 for "lubricated" conditions D = Nominal Diameter
 All torque values are listed in foot-pounds K = 0.17 for zinc plated, dry conditions F = Clamp Load
 Torque values calculated from formula T=KDF, where K = 0.20 for plain and dry conditions

* These are intended to be general specifications. See tractor operators or service manual for exact specifications for your unit.

MAINTENANCE

LUBRICATION RECOMMENDATIONS

Description	Application	General Specification	Recommended Mobil Lubricant
Tractor Hydraulics	Reservoir	JD-20C MF M1135,M1141 FNHM2C134D (FNH201)	Mobilfluid 424
Mower Hydraulics	Reservoir		
Cold Temperatures 0 F Start-Up		ISO 46 Anti-Wear - Low Temp	Mobil DTE 15M
Normal Temperatures 10 F Start-Up		JD-20C MF M1135,M1141 FNH M2C134D (FNH201)	Mobilfluid 424
Normal Temperatures 15 F Start-Up		ISO 46 Anti-Wear	Mobil DTE 25
High Operating Temp. Above 90 F		ISO 100 Anti-Wear	Mobil DTE 18M
Flail Rear Gearbox	Grease	PAO Synthetic Extreme Pressure Gear Lube	Mobil SHC 75W-90 Mobil 1 Synthetic Gear
Cutter Shaft & Ground	Grease	Lithium-Complex	Mobilgrease CM-S
Roller Shaft (Flail)	Gun	Extreme Pressure NLGI 2 - ISO 320	
Drive Shaft Coupler (Flail and Rotary)	Grease Gun	Lithium-Complex Extreme Pressure NLGI2 - ISO 320	Mobilgrease CM-S
Drive Shaft Yoke, U-Joint & Stub Shaft	Grease Gun	Lithium-Complex Extreme Pressure NLGI2 - ISO 320	Mobilgrease CM-S
Boom Swivel	Grease	Lithium-Complex	Mobilgrease CM-S
Boom Cylinder Pivots (Rotary & Flail Boom)	Gun	Extreme pressure NLGI2 - ISO 320	
Deck Boom Pivot & Deck Stop Adjustment (Rotary & Flail)	Grease Gun	Lithium-Complex Extreme pressure NLGI 2 - ISO 320	Mobilgrease CM-S
Deck Spindle (Rotary)	Grease Gun	Tiger Spindle Lubricant part number 06540000	Mobilith SHC 220

MAINTENANCE

POLYCARBONATE CARE & MAINTENANCE

The proprietary UV and Abrasion Resistant surface coating on SHIELDS® SUPERCOATED™ polycarbonate significantly improves performance. Periodic cleaning using proper procedures and compatible cleaners are recommended to prolong service life. Tiger Corp. polycarbonate is SUPERCOATED™ on both sides.

CLEANING THE SUPERCOAT™ HARD-COAT

1. Wash with a mild solution of soap or detergent and lukewarm water.
2. Using a soft cloth or sponge, gently wash the sheet to loosen dirt and grime and rinse well with clean water.
3. To prevent water spotting, thoroughly dry with chamois or cellulose sponge.
4. Avoid the use of abrasive cleaners, squeegees and/or other cleaning implements that may mar or gouge the coating.

CLEANING AGENTS WHICH HAVE BEEN FOUND TO BE COMPATIBLE UNDER LABORATORY CONDITIONS:

- Aqueous Solutions of Soaps and Detergents
Windex¹ Top Job² Joy² Mr. Clean²
Fantastik³ Formula 409⁴ Sumalight D12 Brucodecid
- Organic Solvents
Butyl Cellosolve Kerosene Hexel, F.O. 554 Naphtha (VM&P grade)
Neleco-Placer Turco 5042
- Alcohols
Methanol Isopropyl

All residual organic solvents should be removed with a secondary rinse.

GRAFFITI REMOVAL

Butyl cellosolve (for removal of paints, marking pen inks, lipstick, etc.). The use of masking tape, adhesive tape or lint removal tools works well for lifting off old weathered paints.

To remove labels, stickers, etc., the use of kerosene or VM&P naphtha are generally effective. When the solvent will not penetrate sticker material, apply heat (hair dryer) to soften the adhesive and promote removal.

IMPORTANT: If a material is found to be incompatible in a short-term test, it will usually be found to be incompatible in the field. The converse, however, is not always true. Favorable performance is no guarantee that actual end-use conditions have been duplicated. Therefore, these results should be used as a guide only and it is recommended that the user test the products under actual end-use conditions.

MAINTENANCE

RECOMMENDED FILLING INSTRUCTIONS FOR HYDRAULIC RESERVIORS

When filling or checking the oil level, the unit should be parked on a level surface, shut **"OFF"**, and allowed sufficient time to cool to ambient temperature. Use caution when removing the pressurized breather. Do not place face over opening when removing the breather.

The reservoir should be filled to the top of the lower sight glass on the side of the tank. Do not over-fill. The reservoir has been over-filled when oil is visible in the upper sight glass. If tank has too much oil, the excess may be expelled through the pressurized breather.

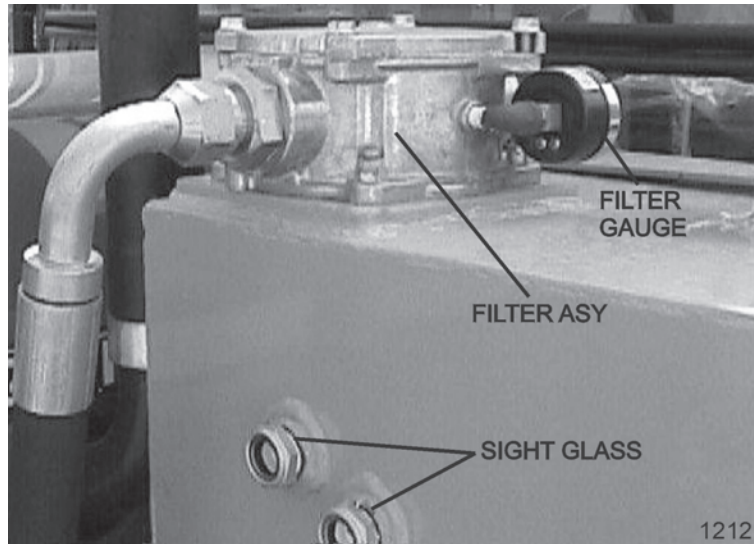

DETAILED MAINTENANCE

REPLACING IN-TANK HYDRAULIC FILTER:

Loosen the four bolts on the top cover of the filter housing. Turn cover counter-clockwise until cover is free. Remove and replace filter. Replace top cover and cover bolts in opposite order as removed.

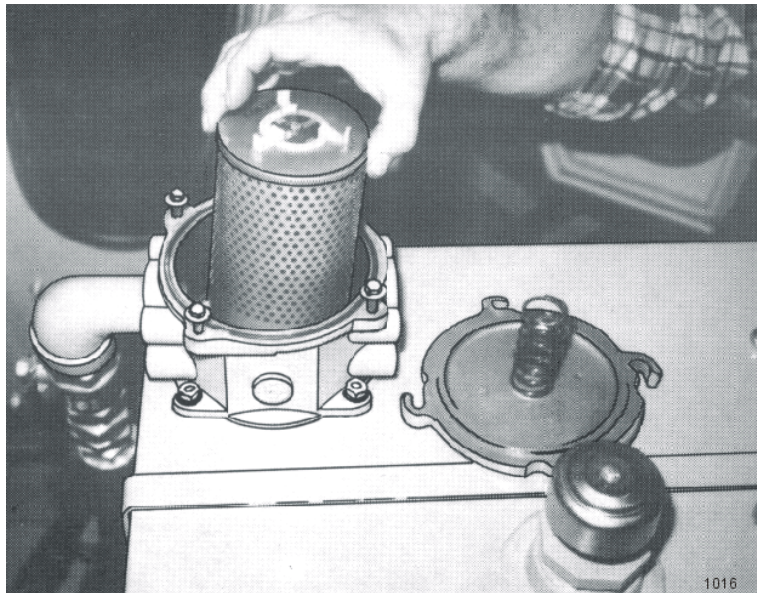

MAINTENANCE

DETAILED MAINTENANCE

REPLACING HIGH PRESSURE HYDRAULIC FILTER ELEMENT:

Assure system has been shut down and de-pressurized. Locate High Pressure Filter housing. Confirm that the element that is about to be installed matches the element p/n on the filter model tag. Example: V3.0510-06 (world line 100, HD049 model) Locate the bottom of the High Pressure Bowl, and use the appropriate spanner wrench –or- ratchet that matches the hex pattern. Using the spanner wrench -or- ratchet and turning in a counterclockwise rotation, (looking at the bottom of the bowl) remove the bowl from the head. The first couple rotations will seam tight as the o-ring passes the sealing flats, once the o-ring has cleared the sealing flats the bowl should spin freely. Taking care not to drop the bowl, finish removing the bowl from the head. **WARNING:** bowl will be full of oil! Pour the oil from the bowl into a container, this oil should be considered contaminated due to the flow direction through the element is outside ~ in. Clean the inside of the bowl if “dirt” is present. Remove the old element from the filter head by pulling with a rotation motion. Dispose of the used element properly. Remove the new element from the packaging. Using your finger, dab and lubricate the o-ring in the top of the new element. Install the new element into and on the mounting boss with in the head; assure that the element is fully seated on the boss. Clean and inspect the o-ring that is affixed in the bowl, lubricate with oil. Using a clockwise rotation, screw the bowl back into the head, assuring that the bowl has not been cross threaded into the head. Continue “tighten” the bowl into the head, using the spanner wrench –or- ratchet, the rotation of the bowl will become tighter once the o-ring engages the sealing flats. Once the bowl has been fully inserted into the head, and the o-ring has reached the sealing flats, the bowl can no longer be “tightened” and bottoms out. Once the bowl has bottomed out, “back-off” the bowl by 1/6 turn, this assures that the o-ring is seated properly with in the sealing flats. Element change out and re-assembly is now complete. Start the machine and inspect the filter area checking that there is no oil leaking from the filter assembly. This is first to be done at 50 hours of operation, then yearly(500 hours) or when indicated by restriction indicator.

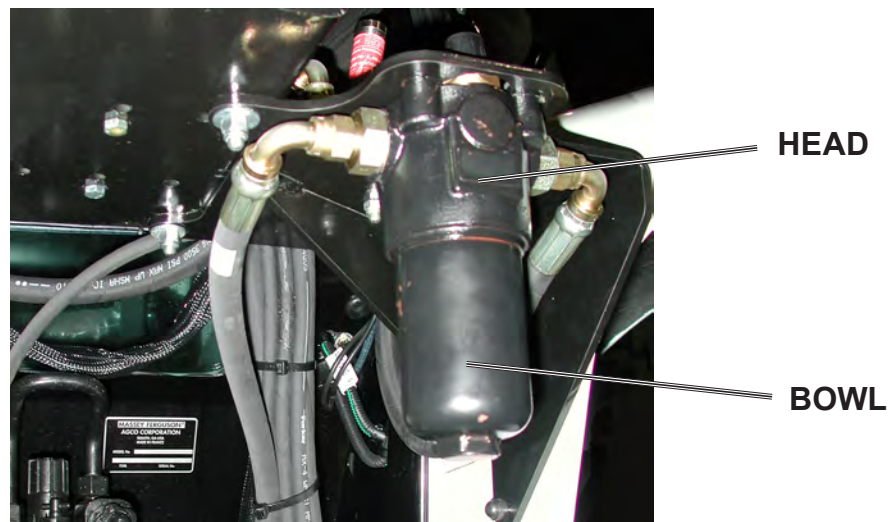

MAINTENANCE

GREASING INNER AND OUTER DRAFT BEAM PIVOT POINTS

Locate the grease zerks on the inner and outer draft beam pivot bosses. Inject Lithium-Complex Extreme Pressure grease conforming to NLGI2-ISO 320 specifications into each zerk until grease protrudes from joints. Grease all pivots daily or every 8 hours of service.

GREASING THE UPPER AND LOWER SHEAVES

Locate the grease zerks on the ends of the upper and lower sheave pins as shown below. Inject Lithium-Complex Extreme Pressure grease conforming to NLGI2-ISO 320 specifications into each pin until it protrudes from the ends. These should also be greased daily or for every 8 hours of service.

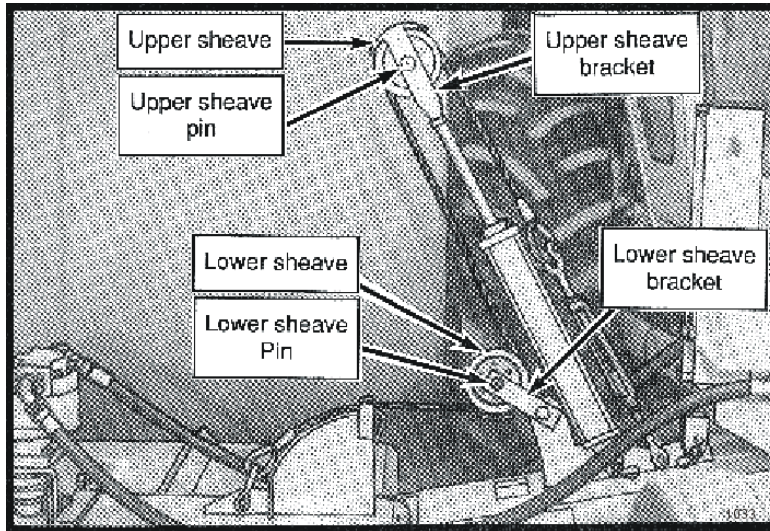

GREASING P.T.O. SHAFTS

After bringing the tractor to a complete stop, shut off the engine and remove the P.T.O. shaft from the tractor. Slide the shaft apart to expose the grease zerk. Grease the shaft with 5 pumps of grease and the U-joints until grease protrudes from caps per the scheduled interval in the maintenance section.

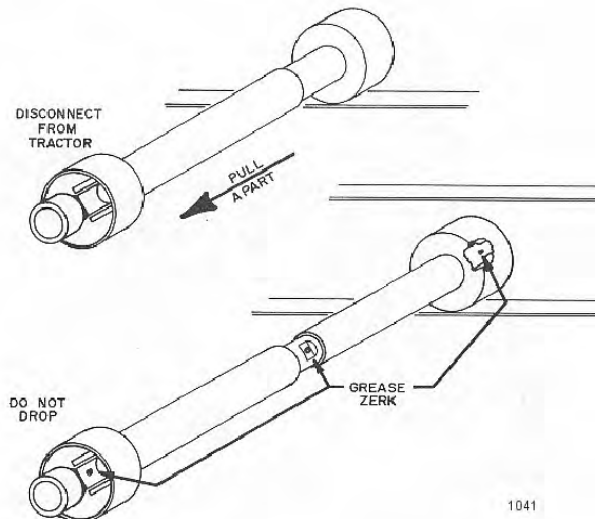

1041

MAINTENANCE

GREASING INNER AND OUTER DRAFT BEAM PIVOT POINTS

Locate the grease zerks on the inner and outer draft beam pivot bosses. Inject Lithium-Complex Extreme Pressure grease conforming to NLGI2-ISO 320 specifications into each zerk until grease protrudes from joints. Grease all pivots

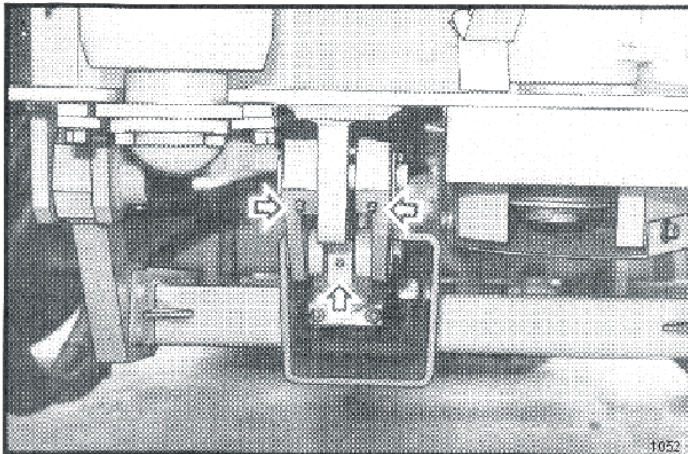
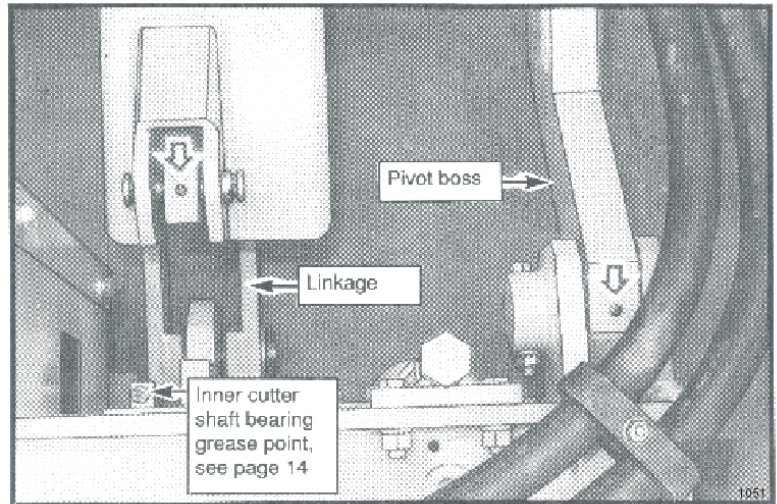
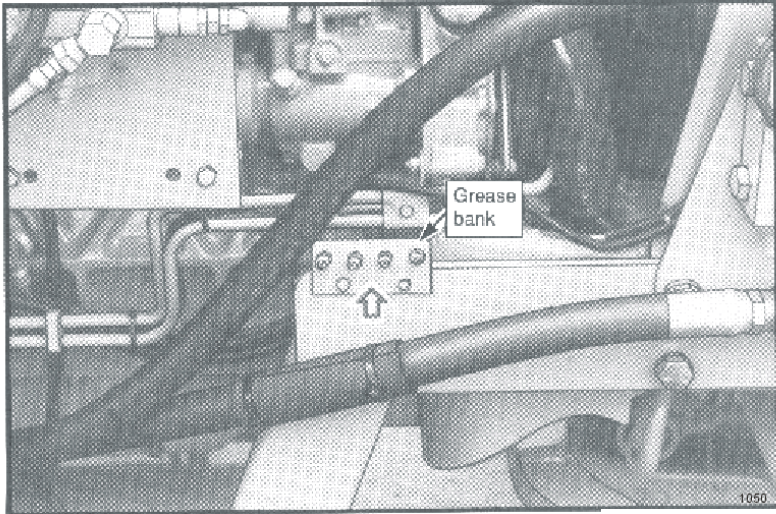

With the cutter head lowered, locate the grease zerks on the linkage and pivot bosses. Inject Lithium-Complex Extreme Pressure grease conforming to NLGI2-ISO 320 specifications until it protrudes from the ends. With the cutter head in this position it is also possible to grease the draft beam cylinder anchors and pins. Now raise the cutter head to expose the remaining zerks on the deck tilt linkages and on the other end of the cylinder.

MAINTENANCE

GREASING THE REAR DRIVE BEARING AND EXTENSION COUPLER SHAFT

Locate the grease zerks for the rear flail drive extension shaft. Make sure the zerks are clean before injecting grease. One pump of grease into flange zerk and shaft coupler once every day or for every 8 hours of service.

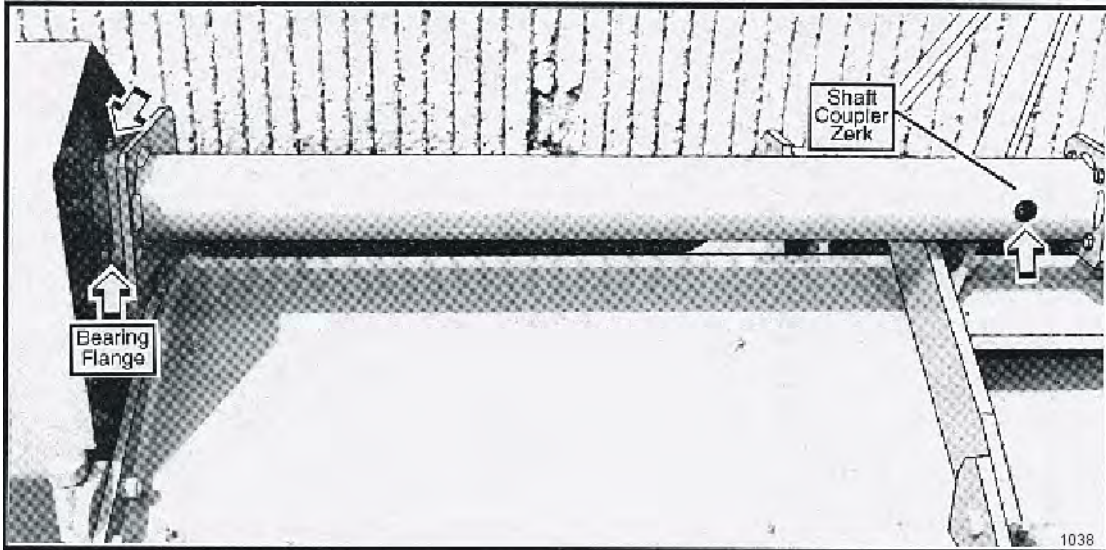

GREASING PUMP DRIVE SHAFT COUPLER

With engine stopped, ensure drive shaft alignment by grasping coupler and sliding back and forth. Coupler should slide freely with approximately 1/8" of end play. If coupler does not slide freely, inspect for loose pump mount bolts, or damaged or loose crank shaft adapter. Inject Lithium-Complex Extreme Pressure grease conforming to NLG12-ISO 320 specifications into coupler until grease begins to protrude from ends. Grease daily or every 8 hours. Do not over grease.

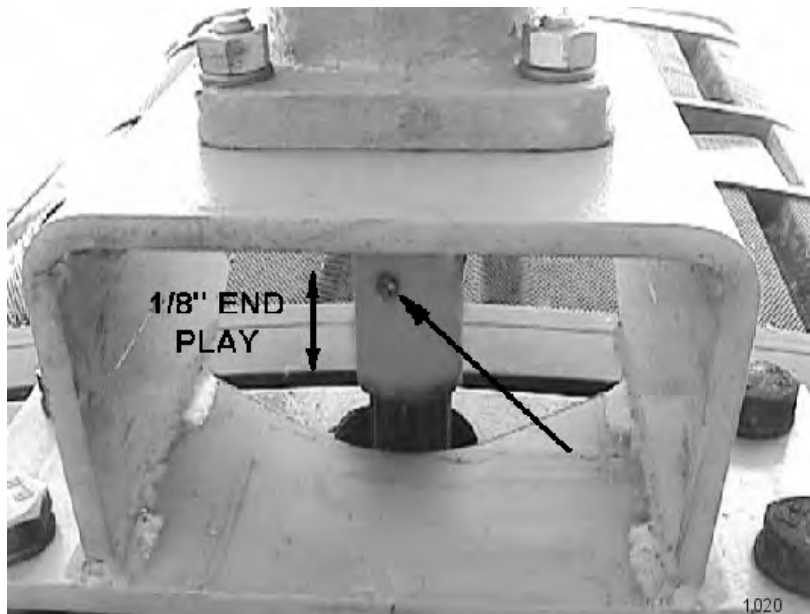

MAINTENANCE

DRIVE SHAFT YOKE, U-JOINT & STUB SHAFT

With engine stopped, inject Lithium-Complex extreme pressure grease conforming to NLGI2-ISO 320 specifications into universal joints and slip yoke until grease appears at the seal. Grease them daily or every 8 hours.

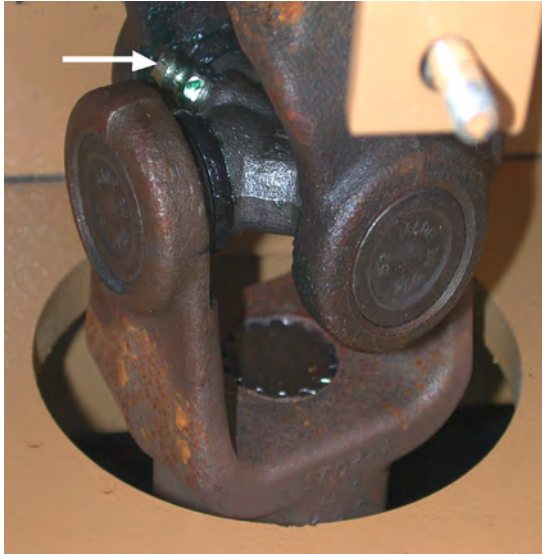

ADJUSTING THE CABLE LIFT

Extend the outboard cylinder until the mower deck touches its stop on the draft beam as shown. NOTE: Make sure the cable turnbuckle is loose enough to allow the cylinder to reach full extension before the head reaches the stop. Now hold the head against the stop and tighten the turnbuckle until the cable is tight. Lower and raise the head to check the adjustment. The head should touch its stop at the same time the cylinder reaches full extension. Tighten turnbuckle lock nuts securely after adjustment is complete.

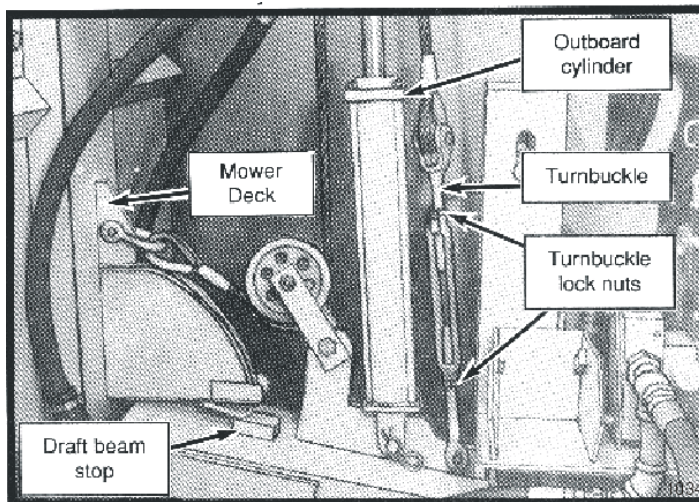

MAINTENANCE

ADJUSTING THE CUTTING HEIGHT

Loosen the four ground roller bracket lock nuts. Loosen the adjustment rod lock nut and turn the adjustment rod to adjust the cutting height. The cutting height is indicated by the end of the adjustment rod on the cutting height decal. When cutting height has been achieved, tighten the ground roller bracket lock nuts and the adjustment rod lock nut securely. Be sure both sides of the flail are adjusted the same.

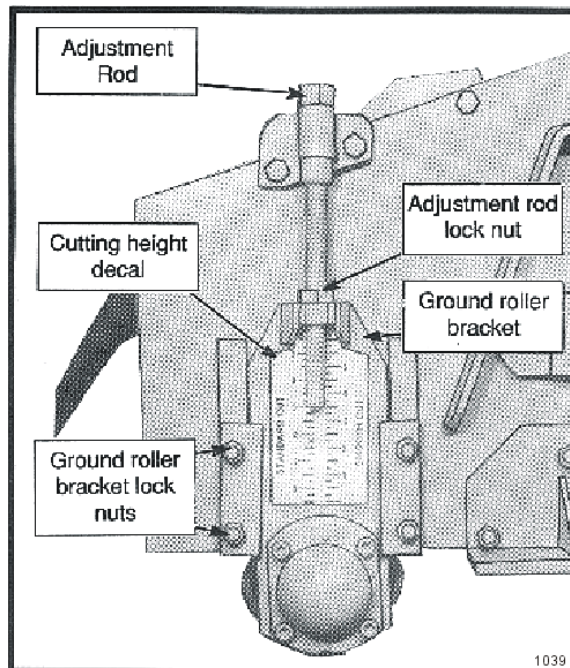

ADJUSTING STANDARD DUTY CUT HEIGHT

To adjust the cutting height of the standard duty flail head the two nuts on the roller shaft brackets must be taken off and moved to the desired location / height. See diagram below. Be sure that both sides of the shaft are adjusted to corresponding holes so the shaft remains level.

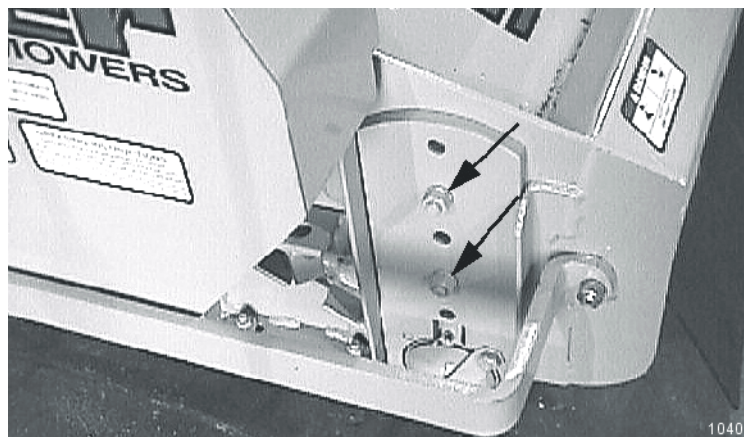

MAINTENANCE

BALL VALVES

The ball valve at the hydraulic reservoir may need to be closed during certain maintenance or repair procedures. **THE BALL VALVES MUST BE OPEN (handle parallel with valve) WHEN TRACT OR IS RE-STARTED OR PUMP IS COUPLED TO MOTOR OR P.T.O. !** Failure to do so may result in component failure!

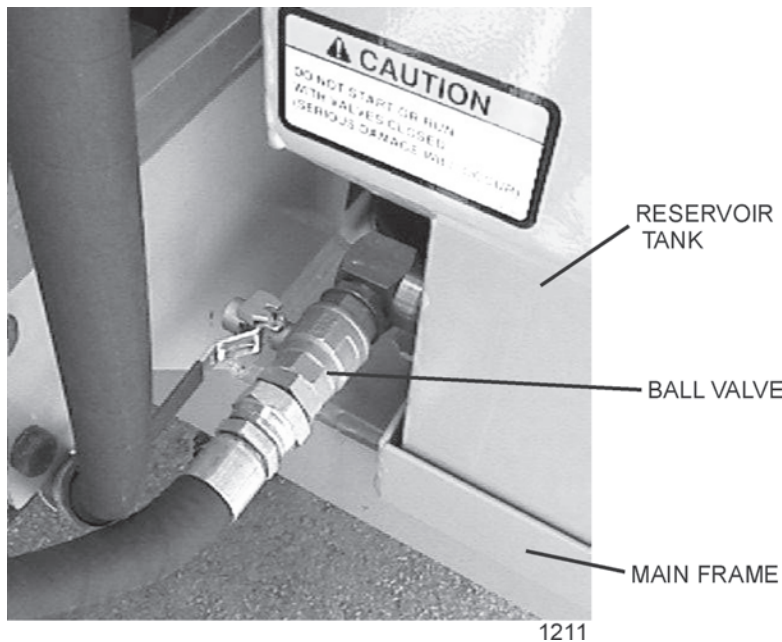

GREASING CUTTER SHAFT – FLAIL MOWERS

Locate grease zerks on each end of cutter shaft(s), these are located on the bearing cover. Normal conditions require one or two pump in each bearing, using Lithium-Complex Extreme Pressure grease conforming to NLGI2-ISO 320 specifications. This is to be done with a standard grease gun daily or at **8 hour intervals**. **CAUTION: Over greasing may cause premature seal failure.**

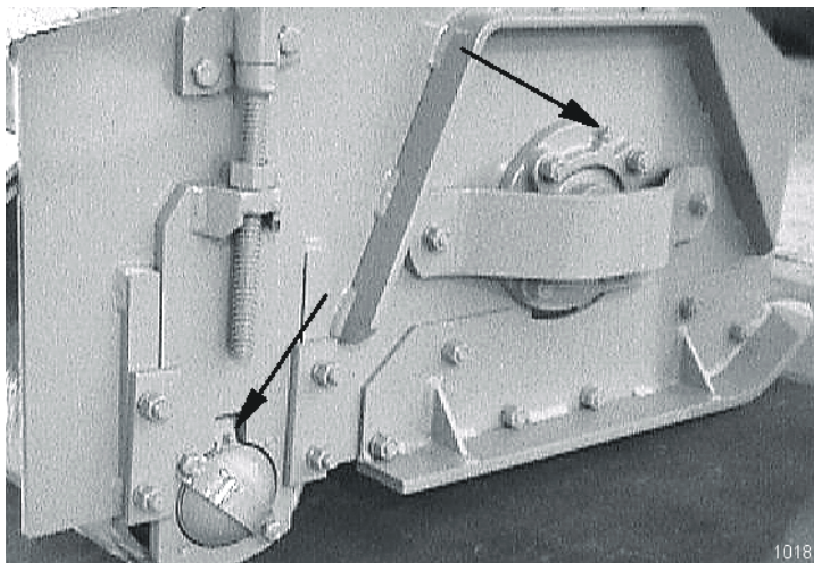

MAINTENANCE

ROSTA TENSIONER

Remove the guard over the belt shield. Then remove the belt shield that covers the tensioner, belt and sheaves.



BELT SHIELD

CUTTERSHAFT
GUARD



Place a straight edge over both sheaves and measure the belt tension(See TENSIONER MEASUREMENT PROCEDURE). To adjust the Rosta Tensioner, first, loosen the Rosta Stop and Rosta bolt that secures the Rosta to the flail. Next use the Wrench (PN# 06401023 available) to adjust the tension of the belt. After the tension has been set, secure the Rosta Stop and re-torque the Rosta Bolt to specs.

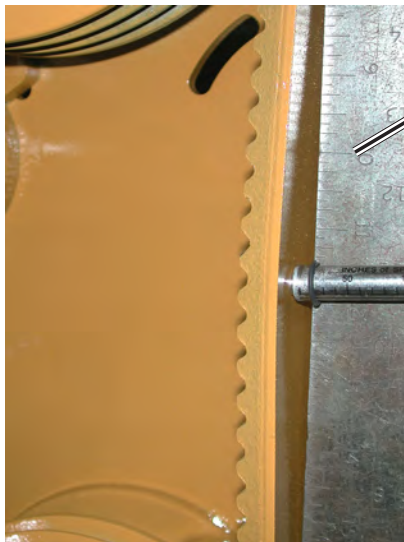

STRAIGHT EDGE

ROSTA STOP

ROSTA WRENCH

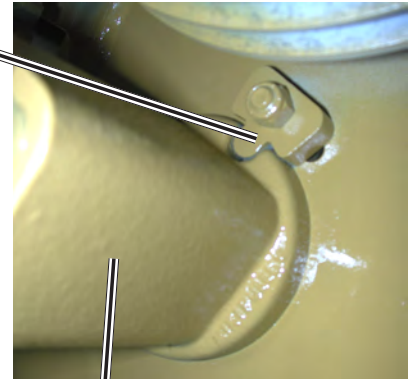

ROSTA
ARM

MAINTENANCE

TENSIONER MEASUREMENT PROCEDURE

1. Measure the Belt Span (SEE SKETCH).
2. Position the bottom of the Large "O" Ring on the Span Scale at the measured Belt Span.
3. Set the Small "O" Ring on the Deflection Force Scale to zero.
4. Place the tension gauge squarely on the belt at the center of the belt span. Apply a force on the plunger perpendicular to the belt span until the bottom of the Large "O" Ring is even with the bottom of a straight edge laid across the sheaves.
5. Remove the tension gauge and read the force applied from the bottom of the Small "O" Ring on the Deflection Force Scale.
6. Compare the force denoted by the Small "O" Ring with the values shown. The force should be between the values given for either a New Belt or Used Belt.
7. Make sure to use the force values in pounds if the span is measured in inches. Use kilograms of force if the span is measured in centimeters.
8. NOTE: The ratio of the deflection to belt span is 1/64 in either units of measurements.

Deflection Force Values - Standard Duty

New Belt: 20 to 25 pounds

Used Belt: 12 to 20 pounds

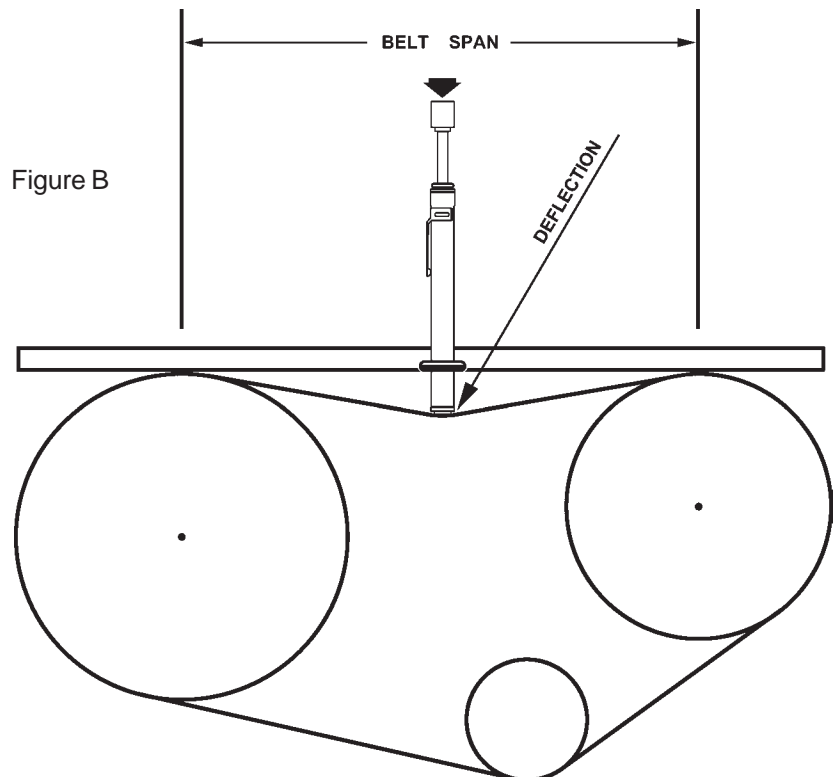
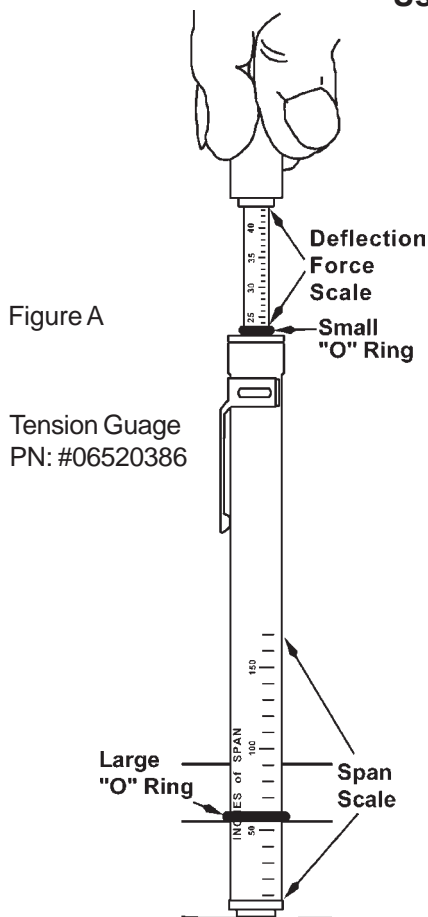

MAINTENANCE

GREASING GROUND ROLLER SHAFT – FLAIL

Locate grease zerks on each end of roller tube at lower rear of head. Normal conditions require one or two pump in each bearing, using Lithium-Complex Extreme Pressure grease conforming to NLGI2-ISO 320 specifications. This is to be done with a standard grease gun daily or at **8 hour intervals**. **CAUTION: Over greasing may cause premature seal failure.**

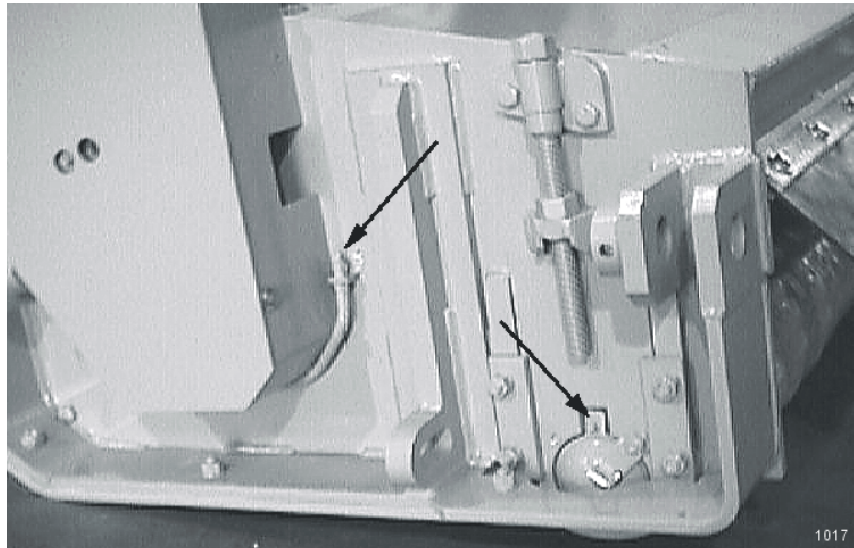

GREASING THE IDLER TENSION ARMS

Locate the access holes and grease zerks in the belt shields of the side and rear flails. Normal conditions require one pump daily or every 8 hours of service with multi purpose grease.

IDLER TENSIONING

Locate the idler tensioning rod for each flail. Loosen the locking nut. Turn the adjusting nut until the washer in between the spring and nuts is flush with the spring housing or guide. Tighten locking nut securely. For standard cut on side flail adjust until the spring washer is flush with the top of the spring housing, as shown below. Use this same method to adjust hydraulically driven rear flails.

MAINTENANCE

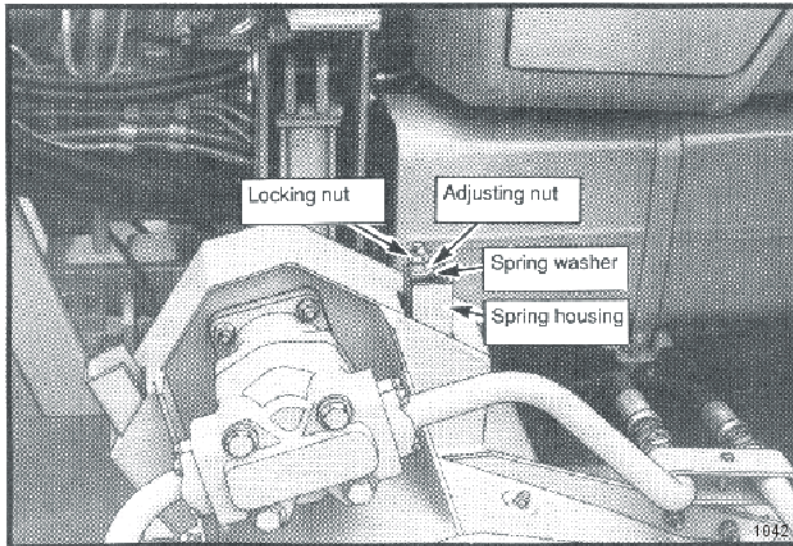

For standard cut on the mechanically driven rear flail mower, adjust so that the spring washer is flush with the spring guide as shown below.

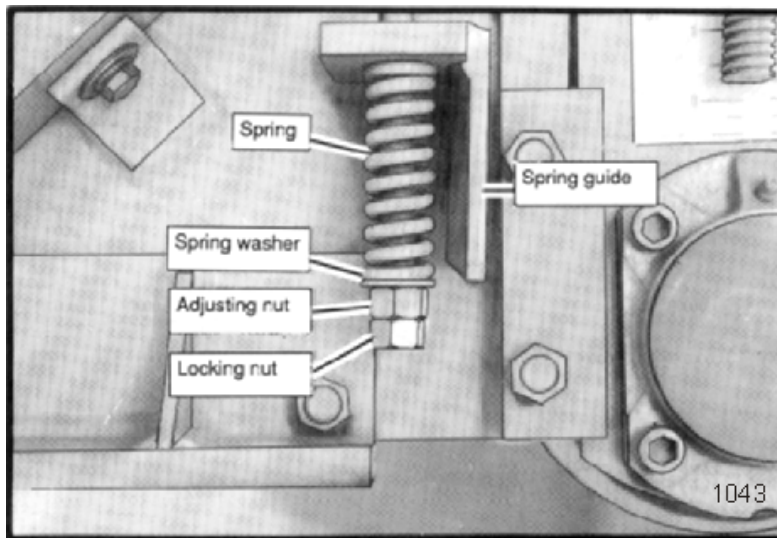

REVERSING MOWER ROTATION OF SIDE AND REAR FLAIL MOWERS

To reverse the rotation of the side and hydraulically driven rear flail, a different idler arm is needed only for side flail. Part No. TF4346 is used in standard rotation. Part No. TF4345 is used in reverse rotation.

When before attempting this procedure be sure all dirt is cleaned away from the motor and around all hose connections. This is to prevent the oil from becoming contaminated. 1-Start by removing the belt shield from the flail mower. 2-Remove the locking and adjusting nut, spring washer and spring from the idler tensioning rod. 3-Disconnect the tensioning rod from the idler arm. 4-Remove the idler arm with the idler pulley attached. 5-Remove the idler pulley from the idler arm and reinstall on the short end of the new idler arm.

MAINTENANCE

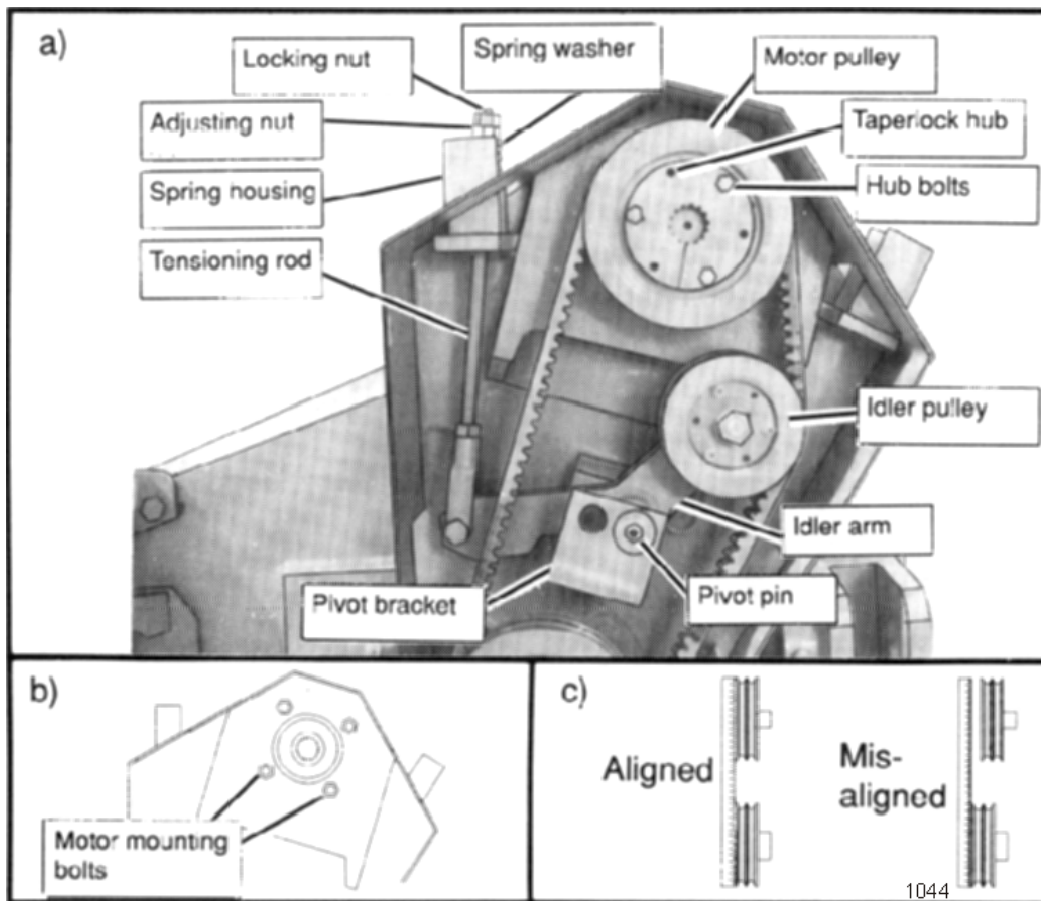

Reinstall the idler arm and pivot pin. The pivot pin is installed into the hole in the pivot bracket closest to the idler pulley. When assembling for **standard** cut rotation, the idler arm is installed with the idler pulley toward the front of the mower with the pivot pin in the front hole. When assembling for **reverse** rotation, with smooth cut knives, the idler arm is installed with the idler pulley toward the rear of the mower with the pivot pin in the rear hole.

Now disconnect the hoses and fittings from the motor and remove the taper-lock hub and pulley from the motor by removing the three hub bolts from the existing positions and inserting simultaneously into the threaded holes. Remove the four bolts holding the motor. Rotate the motor 180° so the hump is opposite the prior position. Reinstall the motor bolts and torque to 75 ft. lbs. Reconnect the hoses and fittings to the motor in the same configuration as before, i.e. the hose that was connected to the front port on the motor should now be connected to the port that is now facing the front.

Reinstall the taper-lock hub and pulley on the motor by installing the hub bolts in the original holes and tightening until the hub just contacts the pulley. Then, position the pulley on the motor shaft approximately 3/16" beyond the idler pulley and tighten and torque the hub bolts to 18 ft. lbs. Be sure the pulleys are vertically aligned when tight (see diagram on previous page), loosen and readjust if needed.

MAINTENANCE

Reinstall the belts and idler tensioning rod. Tighten and lock the tensioning rod as shown previously in the maintenance section. Reinstall the belt shield.

With the motor rotation changed, now all of the knives on the cutter shaft must be changed as required. The cutter shaft rotates in the same direction as the tractor tires when going forward for standard cut knives. The shaft rotates opposite to standard rotation for smooth cut knives. Smooth cut knives should be installed so the cutting edge is forward.

When operating in standard rotation, the front shield must be removed and the baffle installed. When operating in reverse rotation, remove the baffle and install the front shield. Finally, reposition the wear pads on the hoses and replace the zip ties as needed to prevent the hydraulic hoses from rubbing or chafing.

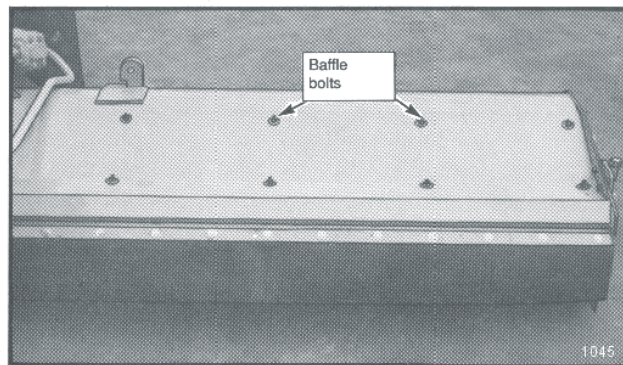
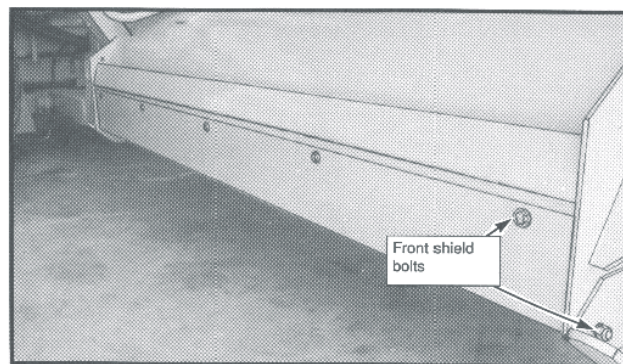

REVERSING MOWER ROTATION REAR MECHANICAL DRIVEN FLAIL MOWERS

Remove the rear shaft guard and disconnect the chain coupling to the shaft. Disconnect the P.T.O. drive shaft from the right angle gear box. Remove the gear box from the flail frame and lay down flat so that gear oil does not leak out.

Switch the top breather vent plug with the drain plug on the bottom. Remove the input shaft guard. The input shaft must be pressed through or turned around so the rear extension is equal to what the original front dimension was. Turn the gear box 180° and install on the flail frame so the chain coupling sprockets are side by side and the breather vent plug is on the top of the case.

(continued on next page)

MAINTENANCE

The sprockets must be aligned and spaced approximately 3/8" apart. When changing from standard cut to smooth cut rotation, a spacer plate may have to be installed between the gear box and the frame. When changing from smooth cut to standard cut rotation the spacer plate is to be omitted. Install the chain for the chain coupling. If there is any binding, or no free movement in the chain, the bearing next to the coupler may be shimmed as required to eliminate the chain binding.

Change all the knives on the cutter shaft as required. The cutter shaft rotates in the same direction as the tractor tires when going forward for standard knives. The cutter shaft rotates opposite the tractor tires for smooth cut knives.

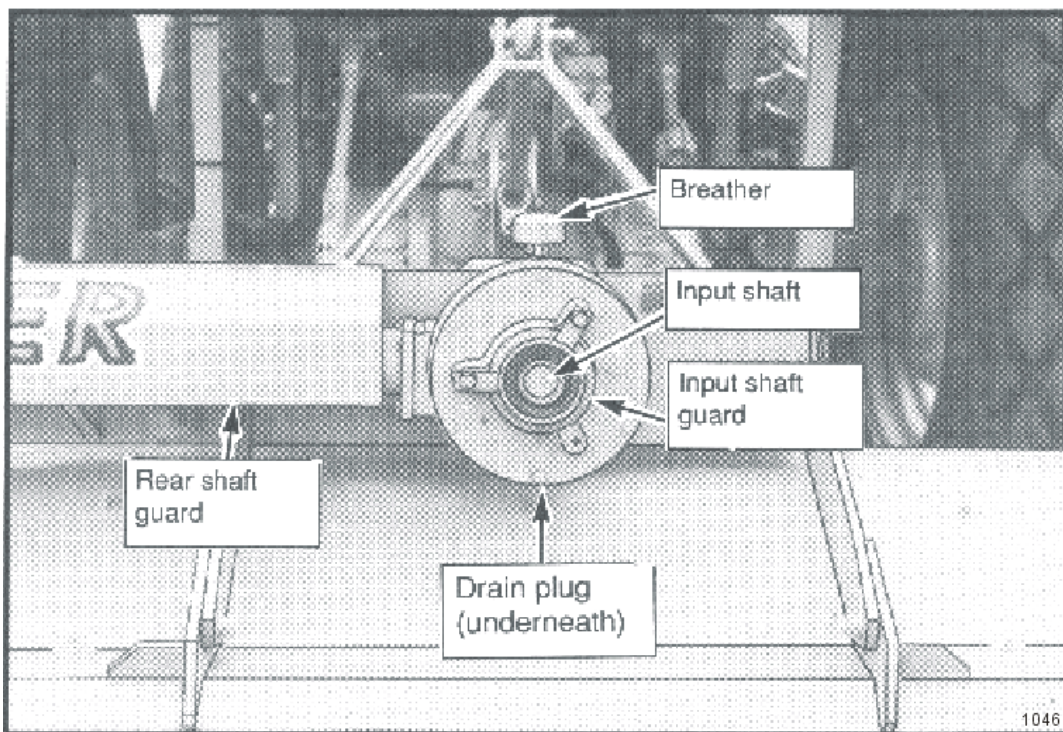

Remove the belt shield. Then remove the adjusting nuts, washer and spring from the idler tensioning rod. Remove the clevis rod and small bushing from the idler arm. Remove the idler arm with the pulley attached. Remove the idler pulley from the idler arm and install the pulley on the other end of the idler arm. Reinstall the idler arm in the pivot bracket. For standard cut rotation the pulley is toward the front, for reverse rotation with smooth knives, the idler pulley is toward the rear. Install the small bushing in the idler arm and connect the idler tensioning rod.

Tighten the adjusting nuts for the idler arm tensioner as shown previously in the maintenance section. Install the belt shield, the shaft guard and P.T.O. shaft guards.

When operating the mower in reverse rotation with smooth cut knives, remove the baffle and install the front shield. When operating the mower in standard rotation with standard cut knives, remove the front shield and install the baffle.

MAINTENANCE

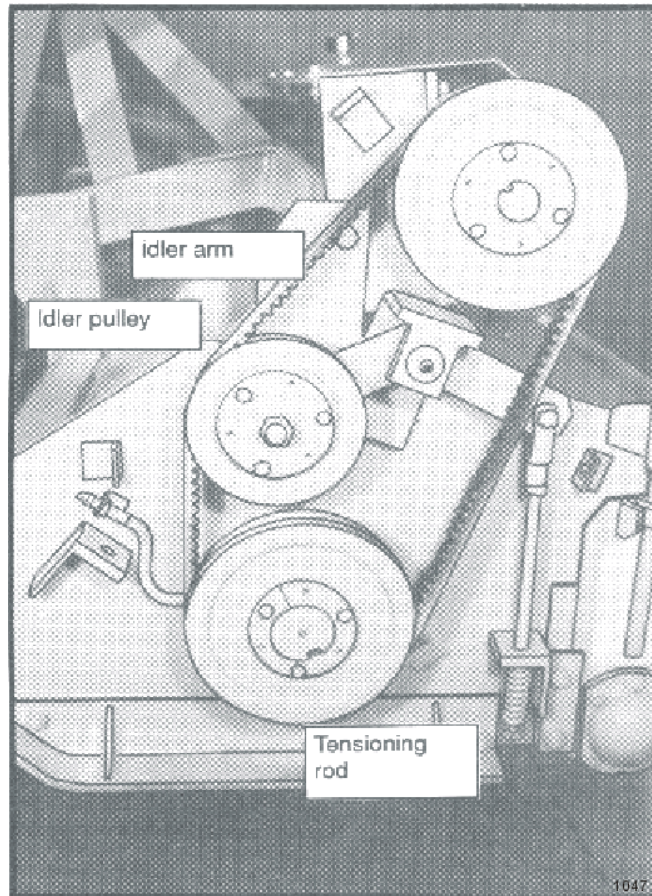

50" BOOM FLAIL KNIFE REPLACEMENT

1 – If knives are damaged or badly worn, they will need to be replaced as a set. Replacing a single knife can cause severe vibration and possible damage to the mower. The knife should not be welded on for any reason.

2 - Always replace the knife bolts when replacing the knives. **DO NOT REUSE THE KNIFE BOLTS OR NUTS.**

3 – Assemble knives, bushings, bolts and nuts as shown in part section of the manual.

4 – Install the locking hex nut so that the flat face of the nut is towards the knife.

4 – apply loctite "271" or equivalent to threads.

5 – Torque nut to 50 ft lbs. Knife must swing freely.

WARNING!



DO NOT re-use the locking hex nuts for mounting the knives. If hex nut become loose, or require removal for knife replacement or any other reason, they must be discarded and replaced with new nuts.

MAINTENANCE

63” BOOM FLAIL KNIFE REPLACEMENT

- 1 – If knives are damaged or badly worn, they will need to be replaced as a set. Replacing a single knife can cause severe vibration and possible damage to the mower.
- 2 – Assemble knives, clevis, bolts and nuts as shown in part section of manual.
- 3 – Install locking hex nut so that the flat face of nut is towards the knife.
- 4 – apply loctite “271” or equivalent to threads.
- 5 – Torque nut to 35 FT. LBS. Knife must swing freely.

WARNING!



DO NOT re-use the locking hex nuts for mounting the knives. If hex nut become loose, or require removal for knife replacement or any other reason, they must be discarded and replaced with new nuts.

WARNING!



Knives should not be welded on for any reason.

STANDARD OR HEAVY DUTY SIDE OR REAR FLAIL KNIFE REPLACEMENT

- 1 – If knives are damaged or badly worn, they will need to be replaced as a set. Replacing a single knife can cause severe vibration and possible damage to the mower.
- 2 – Assemble knives, bushings, collars, bolts and nuts as shown in part section of manual.
- 3 – Install locking hex nut so that the flat face of nut is towards the knife.
- 4 – apply loctite “271” or equivalent to threads.
- 5 – Torque nut to 35 FT. LBS. Knife must swing freely.

WARNING!



DO NOT re-use the locking hex nuts for mounting the knives. If hex nut become loose, or require removal for knife replacement or any other reason, they must be discarded and replaced with new nuts.

WARNING!



Knives should not be welded on for any reason.

MAINTENANCE

RECOMMENDED FILLING INSTRUCTIONS FOR REAR FLAIL GEAR BOX

When filling or checking the fluid level, the unit should be parked on a level surface with rear flail down on surface, shut “**OFF**”, and cold, (at ambient temperature).

Remove the fluid level plug located on the side of the gear box. The gear box should be filled to the bottom of the fluid level hole. If necessary, use 75 - 90 wt. PAO Synthetic Extreme Pressure Gear Lube to raise level to bottom of the hole.

Do not over-fill. excessive gear oil will run back out of the hole. Reinstall fluid level plug into gear box. If gear box has been over-filled, the excess may be expelled through the pressurized breather.

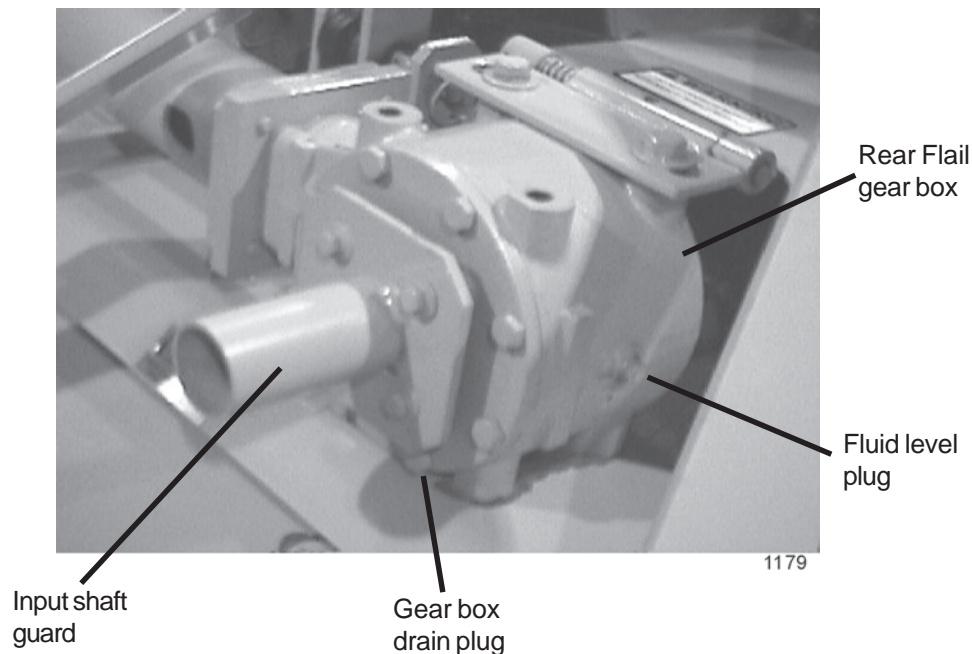

MAINTENANCE

CUTTERSHAFT BEARING REPLACEMENT

- 1 – Remove existing cuttershaft, bearings and string guards.
- 2 – Make sure that the end knives on each end of the cuttershaft are orientated as shown.
- 3 – Apply anti-seize on cuttershaft as shown on next page.
- 4 – Install non-drive side bearing first.
- 5 – Install the top of the string guard on the non-drive side first. Use loctite-271 or equivalent and torque (95 ft-lb or 104ft-lb if you use an extension).
- 6 – Install the bearing and top string guard on the drive side.
- 7 – Center the cuttershaft between the string guards. Use loctite-271 or equivalent and torque (95ft-lb or 104ft-lb if you use an extension) the top string guard on the drive side.
- 8 – Install, use loctite-271 or equivalent, and torque (95ft-lb or 104ft-lb if you use an extension) the bottom string guard on both sides.
- 9 – Make sure the cuttershaft is centered. On the non-drive side, tighten one set-screw in the bearing onto the cuttershaft.
- 10 – Remove the other set-screw and drill a 5/16" hole into the cuttershaft 3/16" deep through the hole in the bearing. BE CAREFULL NOT TO DAMAGE THE THREADS IN THE BEARING HOLE.
- 11 – Replace the set-screw in the bearing, use loctite-271 or equivalent, and tighten onto the cuttershaft through the new hole.
- 12 – Remove the other set-screw and repeat the drilling procedure (Step 10). Replace the set screw as stated in Step 11.
- 13 – Repeat steps 9 through 12 on the drive side.
- 14 – Grease both bearings properly.

MAINTENANCE

CUTTERSHAFT BEARING REPLACEMENT

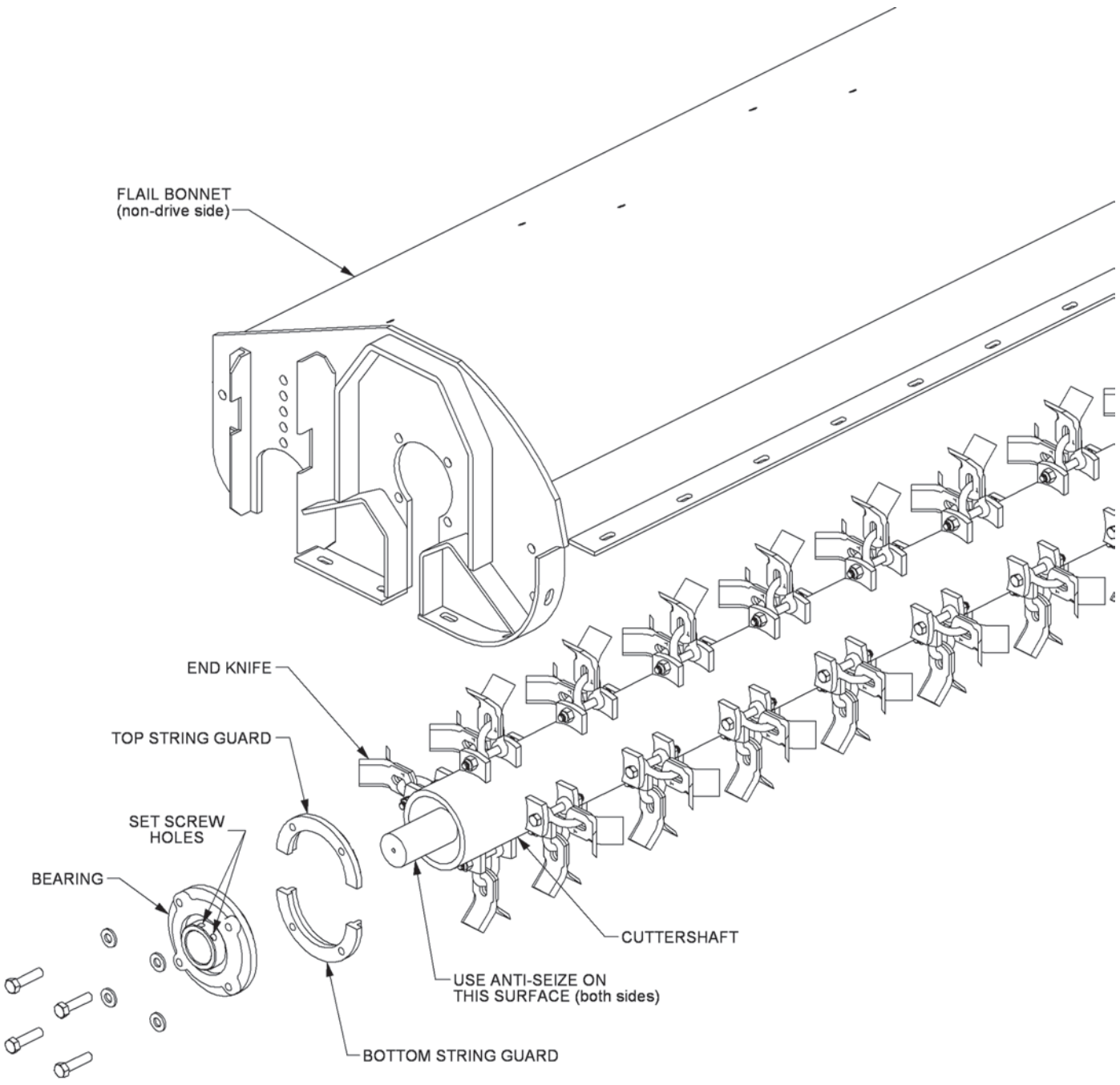

MAINTENANCE

DAILY MAINTENANCE SCHEDULE

The following services should be performed **daily** or every **8 hours** of service, following the detailed maintenance instructions in the operators manual.

- _____ Pump Drive Shaft: Check for end play in drive shaft / coupler and lubricate at zerks.
- _____ Crankshaft adapter: If equipped with rubber grommets check condition, replace if missing or damaged.
- _____ Pivot points: Inject grease until it appears at ends.
- _____ Hydraulic fittings: Check for leaks with paper or cardboard. Tighten fittings or replace hoses immediately.
- _____ Knives: Inspect for missing or damaged knives, change (only complete sets) as needed.
- _____ Belts: Check / Tighten / Replace belts as needed.
- _____ Main Frame / Deck: Unless otherwise specified retorque bolts according to torque specifications in this section.
- _____ Hydraulic Fluid Level: Add, if required, per fluid recommendations.
- _____ Rear Flail Drive, Bearing
Flange and Shaft Couplers: Grease as instructed in the detailed (if applicable) maintenance section.
- _____ Cutter Shaft and Ground Roller: Grease as instructed in the detailed maintenance section

Service performed by: _____ Date: ____/____/____ Hour
Meter: _____

Maintenance Section

** This page may be copied and used as part of the daily maintenance routine.

FORD TS 100A CAB, WOC, SIDE FLAIL

PARTS SECTION

PARTS ORDERING GUIDE

The following instructions are offered to help eliminate needless delay and error in processing purchase orders for the equipment in this manual.

1. The Parts Section is prepared in logical sequence and grouping of parts that belong to the basic machine featured in this manual. Part Numbers and Descriptions are given to help locate the parts and quantities required.

2. The Purchase Order must indicate the **Name and Address** of the person or organization ordering the parts, **who should be charged**, and if possible, the **serial number of the machine** for which the parts are being ordered.

3. The purchase order must clearly list the **quantity of each part**, the complete and correct **part number**, and the basic **name of the part**.

4. The manufacturer reserves the right to substitute parts where applicable.

5. Some parts may be unlisted items which are special production items not normally stocked and are subject to special handling. Request a quotation for such parts before sending a purchase order.

6. The manufacturer reserves the right to change prices without prior notice.

NOTE: When ordering replacement decals, refer to the part numbers and descriptions listed in the safety section in the front of this manual.



1000

For maximum safety and to guarantee optimum product reliability, always use genuine **Tiger** replacement parts. The use of inferior replacement parts may cause premature or catastrophic failure which could result in serious injury or death.

Direct any questions regarding parts to:

Tiger Corporation
3301 N. Louise Ave.
Sioux Falls, SD 57107
1-800-843-6849
1-605-336-7900

PARTS SECTION TABLE OF CONTENTS

SECTION	ASSEMBLY	PAGE
TRACTOR SPECIFIC PARTS:		
TRACTOR MOUNT KIT – MAIN FRAME	06101030	5-4
TRACTOR MOUNT KIT - HYDRAULICS	06101030	5-6
TRAC. MNT. KIT – AXLE / BATT., CAB / WOC	06101030	5-8
CABLE LIFT VALVE – LIFT, CAB / WOC	06101044	5-10
COMBO LIFT VALVE – LIFT, CAB / WOC	06101043	5-12
MIRROR BRACKET		5-14
NON-CAB STEEL CANOPY	06200224	5-16
EXHAUST MOUNT		5-17
FRONT PUMP AND GRILL GUARD - OPTIONAL	06200349	5-18
SOLENOID BRAKE VALVE - OPTIONAL	25342	5-19
SOLENOID VALVE SWITCH WIRING	80155	5-20
COMMON PARTS SECTION:		6-1

TRACTOR MOUNT KIT - MAIN FRAME

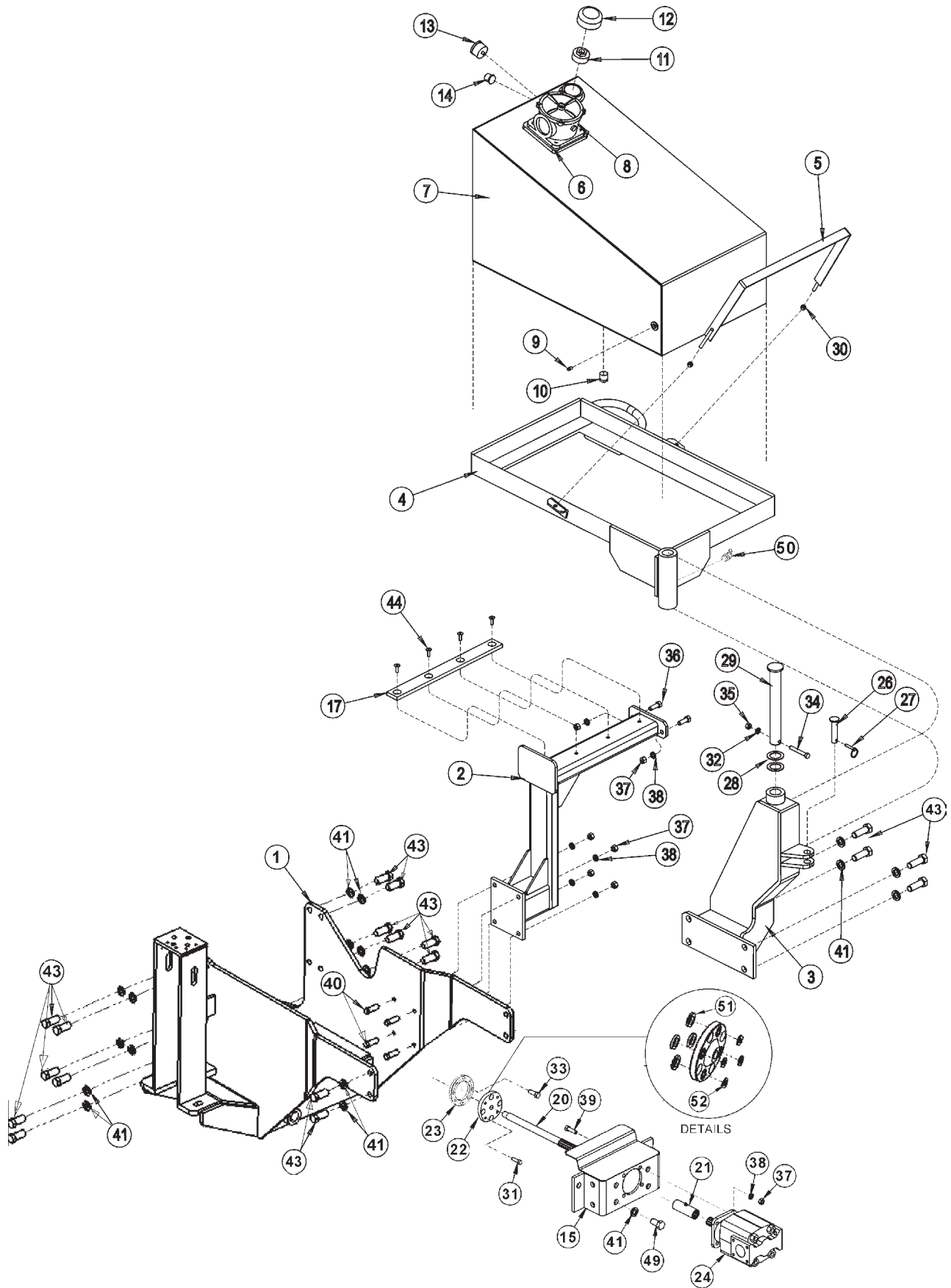

TRACTOR MOUNT KIT - MAIN FRAME

ITEM	PART NO.	QTY.	DESCRIPTION
1	06300014	1	MAIN FRAME, TSA 100
2	06380001	1	REAR RESERVOIR SUPPORT
3	06380002	1	FRONT RESERVOIR SUPPORT
4	32667	1	RESERVOIR TANK FRAME
5	32669	1	RESERVOIR TANK STRAP
	06700006	AVAIL.	RESERVOIR TANK ASSY, TSA.
6	21627	4	NYLOCK NUTS
7	06380000	1	RESERVOIR TANK, TSA
8	35269	1	FILTER ASSY-IN TANK, JIC 10 MIC.
9	6T4197	1	PIPE PLUG
10	6T4200	1	PIPE PLUG
11	33700	1	REDUCER BUSHING
12	31004	1	TANK BREATHER
13	6T0649	1	FILTER GUAGE
14	6T1209	2	TANK SIGHT GLASS
15	32408	1	PUMP MOUNTING BRACKET
16	32690	1	SPACER - MAIN FRAME
17	32671	1	PLASTIC GUIDE
18	6T0111	8	SHIM - WHERE REQUIRED
19	6T0111A	4	SHIM - WHERE REQUIRED
20	34624	1	PUMP DRIVE SHAFT, PMP 29T
21	6T0375B	1	DRIVE SHAFT COUPLER - WITH ZERK
22	6T0389	1	CRANKSHAFT ADAPTER
23	06420006	1	CRANKSHAFT SPACER
24	23152	1	PUMP
25	32382	1	HOSE BRACKET
26	6T0107	1	TRAVEL LOCK PIN
27	RD1032	1	LYNCH PIN
28	6T2617	2	BUSHING - AS NEEDED
29	TB1025	1	PIN
30	21627	2	NYLOCK NUT - 3/8"
31	06535000	4	CAPSCREW, 7/16x1 1/4, NC, CUTOFF
32	21989	2	LOCKWASHER - 7/16"
33	06530503	4	CAPSCREW, SKTHD, 12MMx30MM(1.75)
34	21688	1	CAPSCREW - 7/16" X 3 1/4"
35	21675	1	HEX NUT - 7/16"
36	21731	2	CAPSCREW - 1/2" X 1 1/2"
37	21725	10	HEX NUT - 1/2"
38	21990	10	LOCKWASHER - 1/2"
39	21732	4	CAPSCREW - 1/2" X 1 3/4"
40	21733	4	CAPSCREW - 1/2" X 2"
41	24881	16	LOCKWASHER - 20MM
42	21682	1	CAPSCREW, 7/16 X 1-3/4 NC
43	31731	16	CAPSCREW - 20MM X 50MM
44	28734	4	CAPSCREW - 3/8" X 1" TAPERED
45	21989	1	LOCKWASHER, 7/16
46	21675	1	HEX NUT, 7/16 NC
47	32703	4	CAPSCREW - 20MM X 100MM
48	TB3012	1	HOSE BRACKET
49	24860	6	CAPSCREW - 20MM X 40MM
50	6T3208	1	GREASE ZERK, 1/8 X 45
51	06537004	4	WASHER, NEOPRENE, .75x1.25x.19
52	24937	4	FLAT WASHER
*	33895	AVAIL	KIT CRANK SHAFT (INCLUDES ITEMS 20,21,22)

TRACTOR MOUNT KIT - HYDRAULICS, BRAKE VALVE

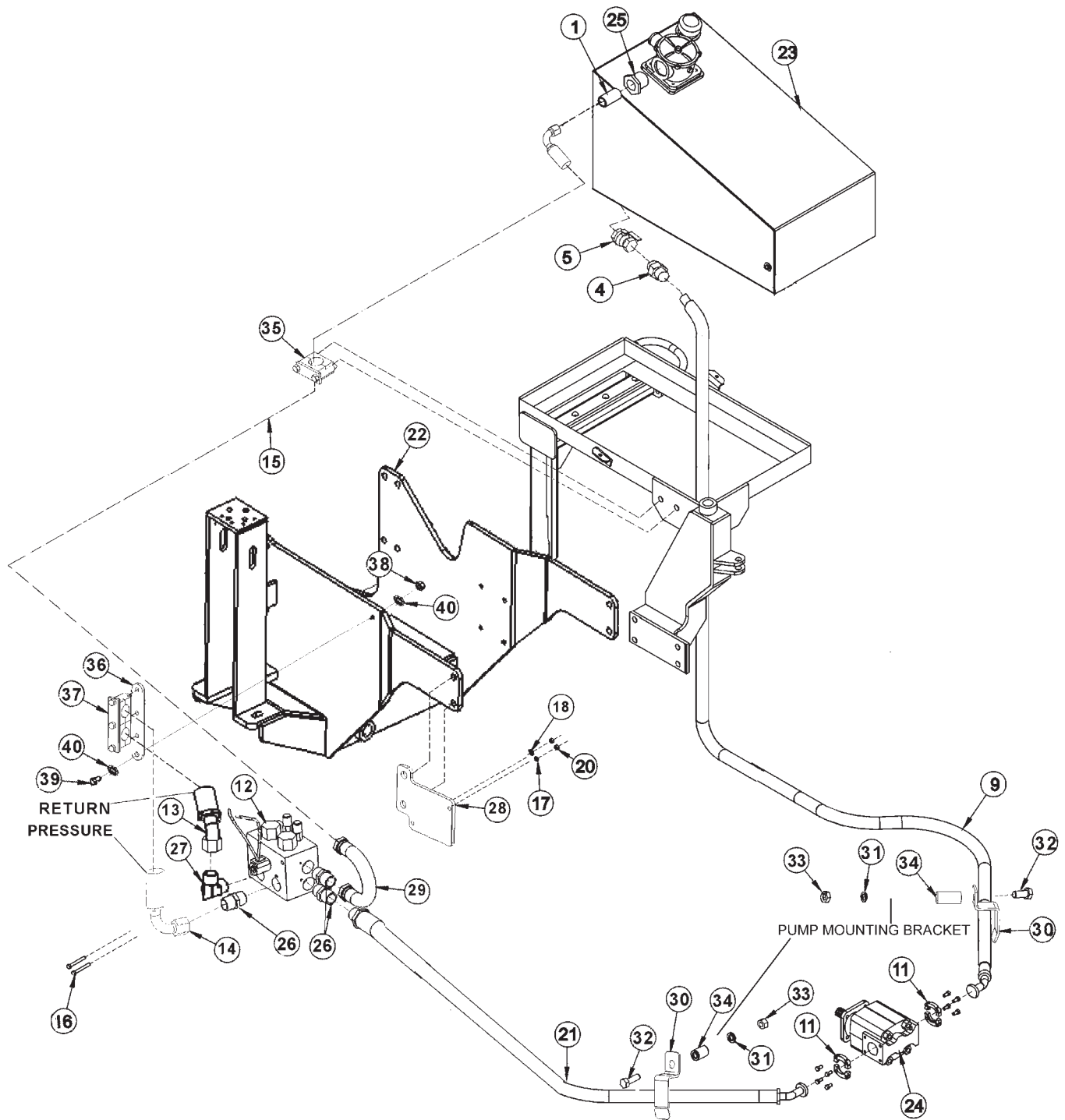

06101030 HYDRAULICS
06101033 HYDRAULICS

TRACTOR MOUNT KIT - HYDRAULICS, BRAKE VALVE

ITEM	PART NO.	QTY.	DESCRIPTION
1	32869	1	NIPPLE,MALE LONG,1MOR X 1MJ
4	34067	1	ADAPTER,1 1/4MORX1 1/4MJ
5	34069	1	BALL VALVE,1 1/4FOR
7	23568	4	HOSE CLAMP (NOT SHOWN)
8	6T3200	3	SPLIT HOSE (NOT SHOWN)
9	06500065	1	HOSE,1 1/4x55(1 1/4FJXx20FLG45)
11	TF4852	2	#20 FLANGE KIT
12	34115	1	SOLENOID BRAKE VALVE
13	06500085	1	HOSE,1x127(1FJX45x1MJ)
14	06500084	1	HOSE,1x127(1FJX90x20FLG45)310
15	34311	1	HOSE,1x125 (1MJx1FJx90)
16	21644	2	CAPSCREW - 3/8" X 5"
17	6T2665	1	STAR LOCKWASHER - 3/8"
18	21988	1	LOCKWASHER - 3/8"
19	22016	2	FLATWASHER - 3/8"
20	21625	2	HEX NUT - 3/8"
21	06500066	1	HOSE,1x37(1FJXx20FLG45)
22	*	REF.	MAIN FRAME - REFER TO MAIN FRAME PARTS
23	*	REF.	RESERVOIR TANK - REFER TO MAIN FRAME PARTS
24	*	REF.	FRONT PUMP - REFER TO MAIN FRAME PARTS
25	33424	1	ADAPTER,1 1/4MORB X 1FOR, LONG
26	33555	3	ADAPTER,1MORBx1MJIC
27	34117	1	ELBOW,1MOR X 1MJ90,FORGED
28	06400114	1	MNT,BRAVE VALVE
29	06506012	1	PRFRMD,BRKVLV,4x1FJXx1FJX(180)
30	32382	2	BRACKET,HOSE
31	24881	2	LOCKWASHER,20MM
32	24860	2	CAPSCREW,20MMX40MM(2.5 PITCH)
34	34048	2	SPACER,2.25X1.25X.813
35	06505017	1	CLAMP KIT,1 HOSE,1"
36	35271	1	CLAMP PLATE,MID
37	35131	1	CLAMP KIT,COOLER,TRUCKAT
38	21675	1	HEX NUT,7/16 NC
39	21682	1	CAPSCREW,7/16 X 1-3/4 NC
40	21989	1	LOCKWASHER,7/16

TRACTOR MOUNT KIT - BRACE/BATT, CAB/WOC

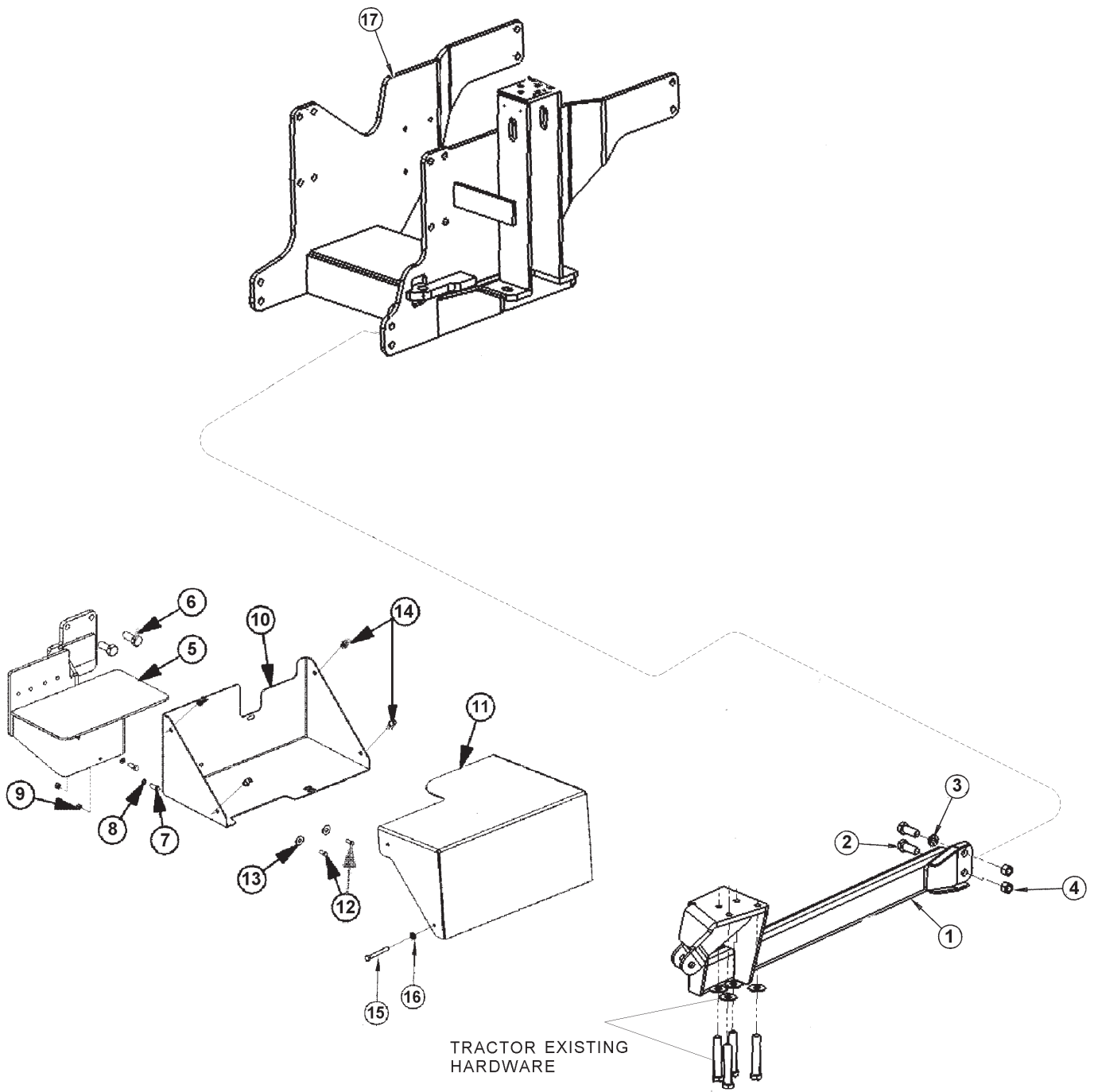

TRACTOR MOUNT KIT - BRACE/BATT, CAB/WOC

ITEM	PART NO.	QTY.	DESCRIPTION
1	06300011	1	AXLE BRACE, RH NHTSA 115
1A	06300012	1	AXLE BRACE, LH NHTSA 115
2	21833	2	CAPSCREW - 3/4" X 2 1/4"
3	21993	8	LOCKWASHER - 3/4"
4	21825	6	HEX NUT - 3/4"
5	06370011	1	BATT MNT, TS 100-135A
6	*	2	EXISTING HARDWARE
7	21580	2	CAPSCREW - 5/16" X 1" NC
8	21987	2	LOCKWASHER - 5/16"
9	21575	2	HEX NUT, 5/16 NC
10	06410146	1	COVER, BOT, BATT, TS 100-135A
11	06410145	1	COVER, TOP, BATT, TS 100-135A
12	21629	2	CAPSCREW - 3/8" X 3/4" NC
13	21988	2	LOCKWASHER - 3/8"
14	35176	4	U NUT 1/4" X 3/4"
15	21529	4	CAPSCREW - 1/4" X 3/4" NC
16	21986	4	LOCKWASHER - 1/4"
17	*	REF.	MAIN FRAME - REFER TO MAIN FRAME PARTS

CABLE LIFT VALVE - SIDE FLAIL, CAB/WOC

HOSE ROUTING

A - TO OUTBOARD CYLINDER BUTT

C - TO INBOARD CYLINDER GLAND

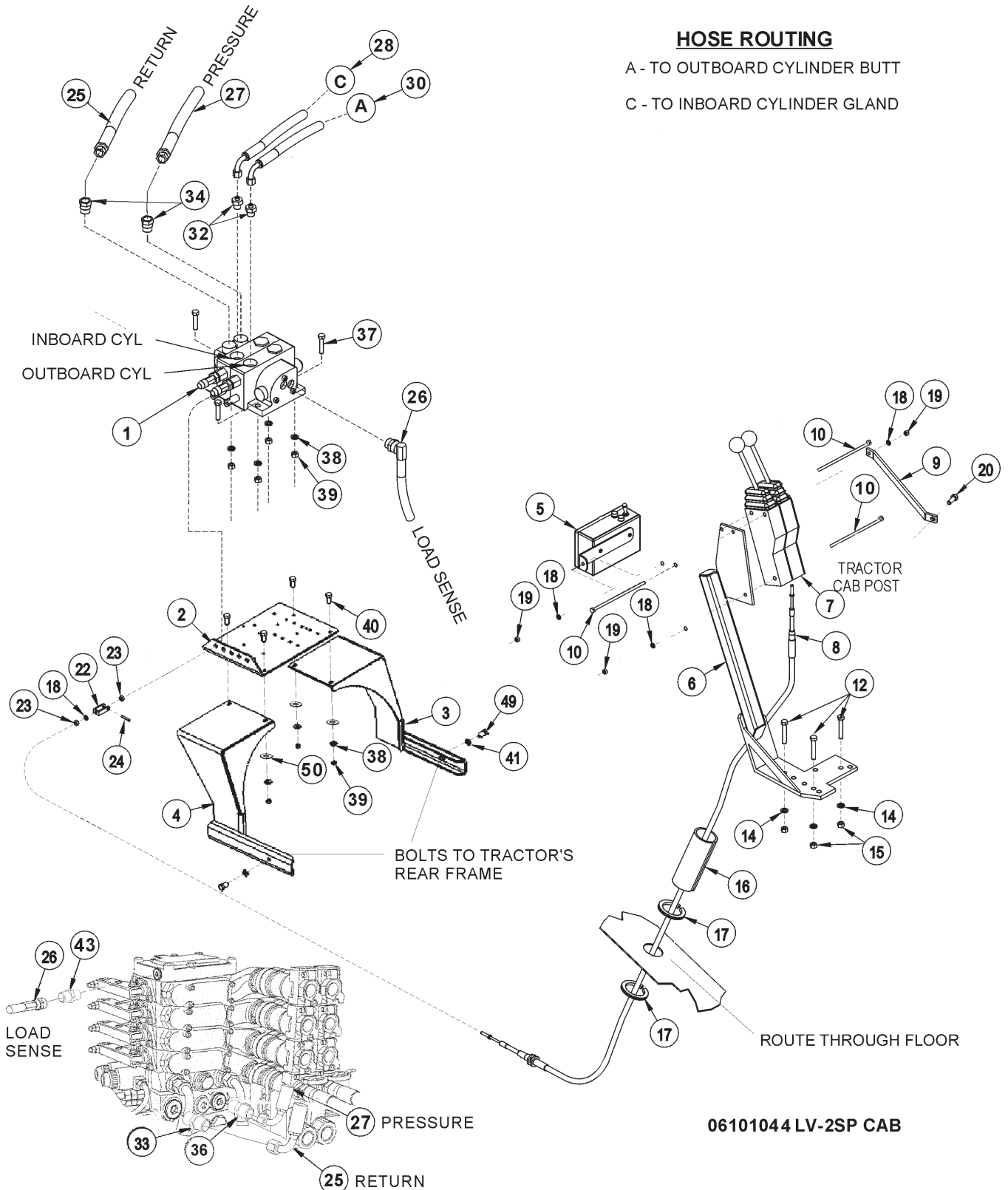

CABLE LIFT VALVE - SIDE FLAIL, CAB/WOC

ITEM	PART NO.	QTY.	DESCRIPTION
1	31320	1	VALVE,2SP,HSC,TM,LS
2	34622	1	VALVE MOUNTING PLATE
3	06340008	1	VALVE MOUNTING ANGLE, LF
4	06340009	1	VALVE MOUNTING ANGLE, RF
5	34520	1	SWITCH BOX, BOOM
6	23865B	1	CABLE CONTROL MOUNTING BRACKET
7	6T1251	2	CABLE CONTROL BOX
8	34623	2	CONTROL CABLE 122"
9	30750A	1	SUPPORT BRACKET
10	21544	3	CAPSCREW 1/4" X 5"
12	21635	3	CAPSCREW 3/8" X 2 1/4"
14	22016	3	FLATWASHER 3/8"
15	21627	3	NYLOCK NUT 3/8"
16	6T3200	1	SPLIT HOSE 6" LONG
17	TB3440	8"	TRIMLOCK
18	21986	5	LOCKWASHER 1/4"
19	21525	3	HEX NUT 1/4"
20	23113	1	CAPSCREW 10MM X 30MM (1.5 PITCH)
22	6T4411	2	CABLE CLEVIS
23	21500	4	HEX NUT 1/4" UNF
24	6T3017	2	ROLL PIN
25	06500063	1	HOSE,1/2x30(3/4FJX90 x (RETURN)
26	06500064	1	HOSE,1/4x18(3/8ORB90x5/16FJX) (LOAD SENSE)
27	06500062	1	HOSE,1/2x30(1/2FJX90 x 1/2FJX90L) 195 (PRESSURE)
28	34631	1	HOSE,1/4x126(3/8FJXx3/8FJX90)
30	33492	1	HOSE,1/4x138(3/8FJX90x3/8FJX)
32	34396	2	ADPTR,.06 RSTRCTR,1/2ORBx3/8MJ
33	06503012	1	ADPTR,27MMORBx3/4MJ
34	06503011	2	ADAPTER,5/8ORBx1/2MJ
36	33463	1	ADAPTER
37	21631	4	CAPSCREW 3/8" X 1-1/4"
38	21988	8	LOCKWASHER 3/8"
39	21625	8	HEX NUT 3/8"
40	21630	4	CAPSCREW 3/8" X 1"
41	21990	2	LOCKWASHER 1/2
43	06503002	1	ADAPTER,12MMORBx5/16MJ
49	21729	2	CAPSCREW 1/2" X 1" NC
50	22016	4	FLATWASHER 3/8"
**	34618	38"	HOSE SLEEVE (NOT SHOWN)

COMBO LIFT VALVE - SIDE FLAIL, CAB/WOC

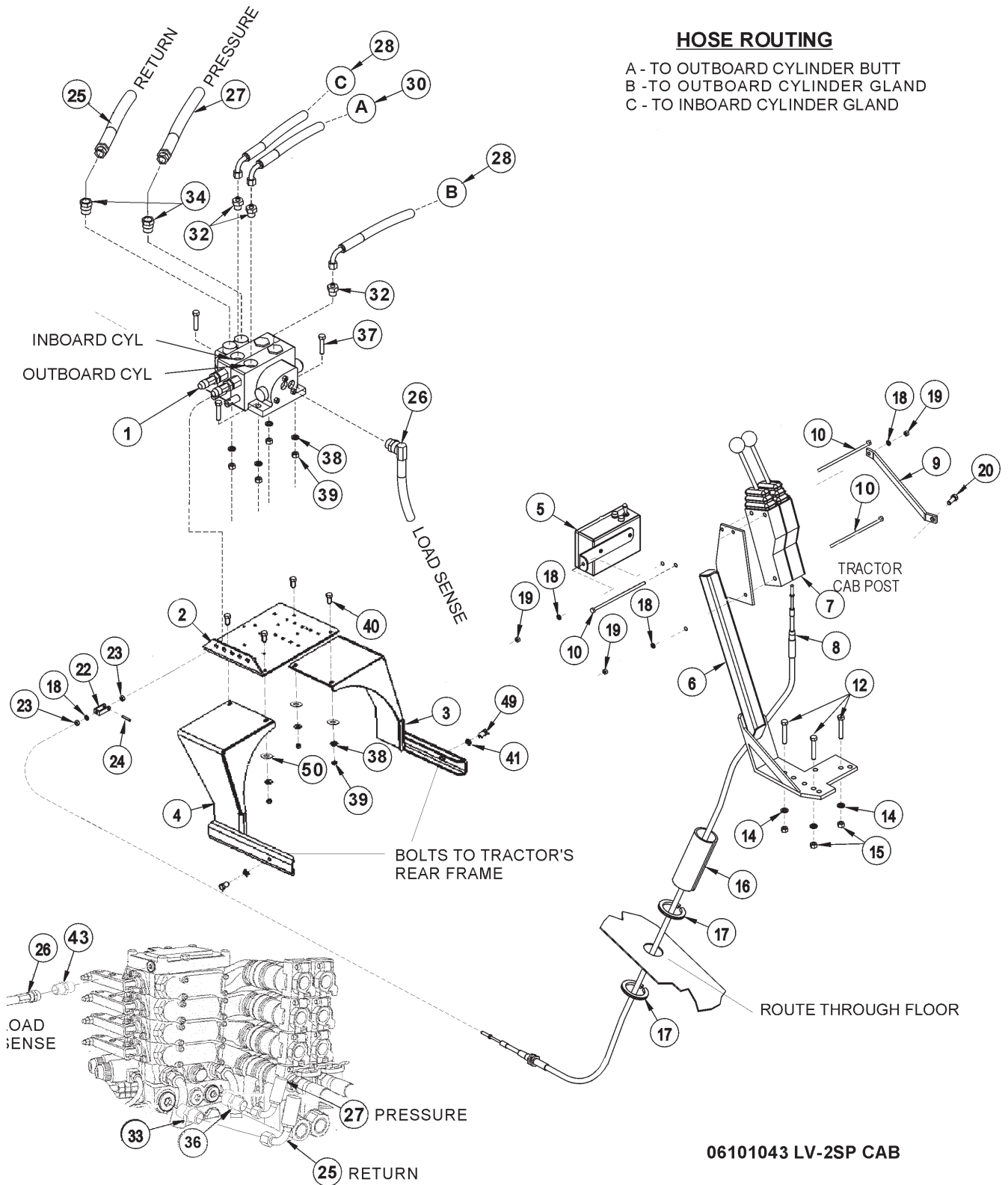

COMBO LIFT VALVE - SIDE FLAIL, CAB/WOC

ITEM	PART NO.	QTY.	DESCRIPTION
1	31322	1	VALVE,2SP,HSC, COM
2	34622	1	VALVE MOUNTING PLATE
3	06340008	1	VALVE MOUNTING ANGLE, LF
4	06340009	1	VALVE MOUNTING ANGLE, RF
5	34520	1	SWITCH BOX, BOOM
6	23865B	1	CABLE CONTROL MOUNTING BRACKET
7	6T1251	2	CABLE CONTROL BOX
8	34623	2	CONTROL CABLE 122"
9	30750A	1	SUPPORT BRACKET
10	21544	3	CAPSCREW 1/4" X 5"
12	21635	3	CAPSCREW 3/8" X 2 1/4"
14	22016	3	FLATWASHER 3/8"
15	21627	3	NYLOCK NUT 3/8"
16	6T3200	1	SPLIT HOSE 6" LONG
17	TB3440	8"	TRIMLOCK
18	21986	5	LOCKWASHER 1/4"
19	21525	3	HEX NUT 1/4"
20	23113	1	CAPSCREW 10MM X 30MM (1.5 PITCH)
22	6T4411	2	CABLE CLEVIS
23	21500	4	HEX NUT 1/4" UNF
24	6T3017	2	ROLL PIN
25	06500063	1	HOSE,1/2x30(3/4FJX90x1/2FJX90L)195deg(RETURN)
26	06500064	1	HOSE,1/4x18(3/8ORB90x5/16FJX) (LOAD SENSE)
27	06500062	1	HOSE,1/2x30(1/2FJX90 x 1/2FJX90L) 195 (PRESSURE)
28	34631	2	HOSE,1/4x126(3/8FJXx3/8FJX90)
30	33492	1	HOSE,1/4X138(3/8FJX90X3/8FJX)
32	34396	3	ADPTR,.06RSTRCTR,1/2ORBx3/8MJ
33	06503012	1	ADPTR,27MMORBx3/4MJ
34	06503011	2	ADAPTER,5/8ORBx1/2MJ
36	33463	1	ADAPTER
37	21631	4	CAPSCREW 3/8" X 1-1/4"
38	21988	8	LOCKWASHER 3/8"
39	21625	8	HEX NUT 3/8"
40	21630	4	CAPSCREW 3/8" X 1"
41	21990	2	LOCKWASHER 1/2
43	06503002	1	ADAPTER,12MMORBx5/16MJ
49	21729	2	CAPSCREW 1/2" X 1" NC
50	22016	4	FLATWASHER 3/8"
**	34618	38"	HOSE SLEEVE (NOT SHOWN)

MIRROR BRACKET

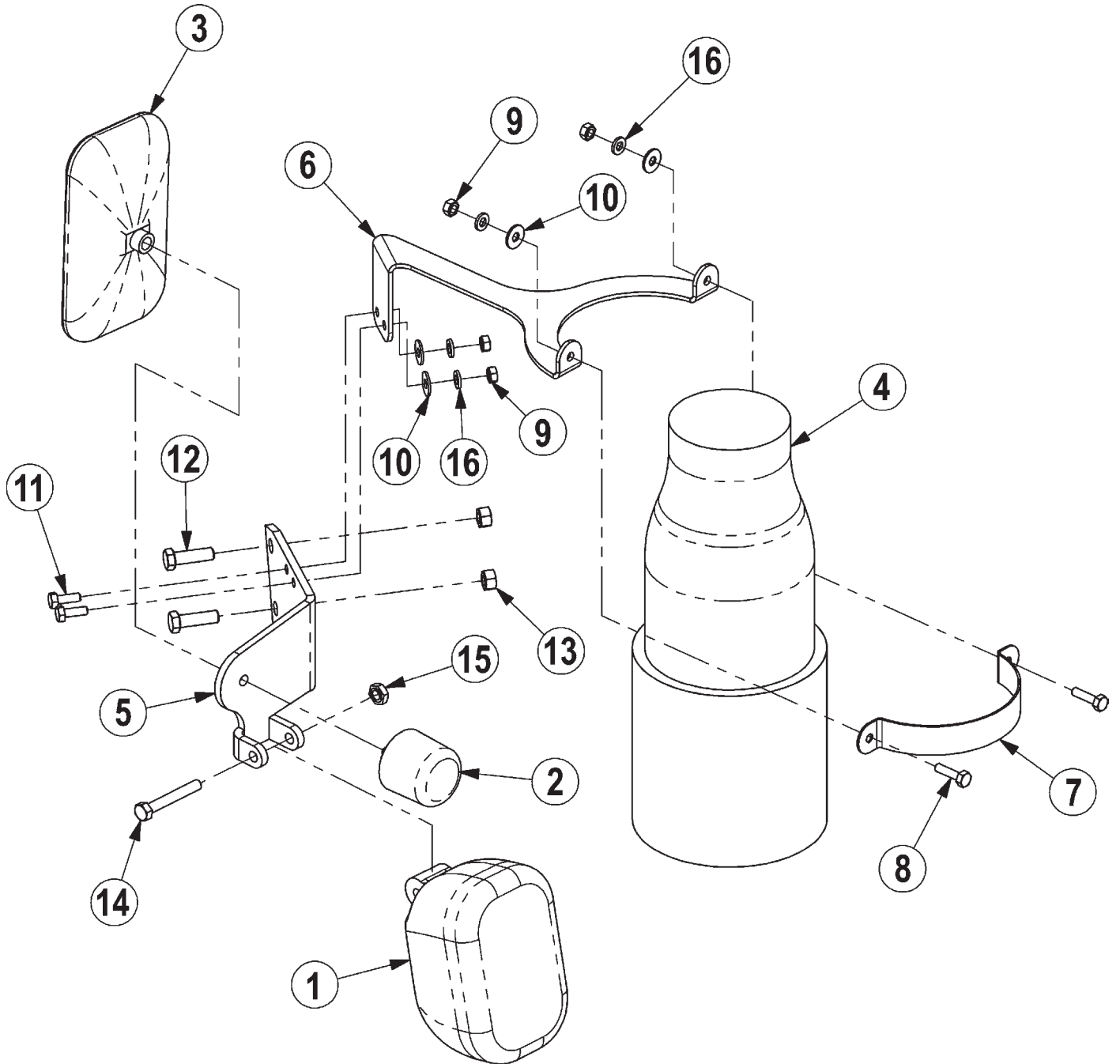

MIRROR BRACKET

ITEM	PART NO.	QTY.	DESCRIPTION
1	*	1	WORK LIGHT (EXISTING)
2	*	1	MIRROR KNOB (EXISTING)
3	*	1	MIRROR (EXISTING)
4	*	1	EXHAUST MUFFLER (EXISTING)
5	06370008	1	MNT,MIRROR/LIGHT,TS115A
6	06410141	1	COLLAR,EXHAUST,TS115A
7	06410142	1	COLLAR,CLAMP,EXHAUST,TS115A
8	21530	2	CAPSCREW,1/4 X 1 NC
9	21525	4	HEX NUT,1/4 NC
10	22014	4	FLATWASHER,1/4
11	21529	2	CAPSCREW,1/4 X 3/4 NC
12	21631	2	CAPSCREW,3/8" X 1 1/4" NC
13	21627	2	NYLOCK,3/8" NC
14	21585	1	CAPSCREW, 5/16" X 2 1/4" NC
15	21529	1	NYLOCK, 5/16" NC
16	21986	4	LOCKWASHER,1/4

BOOM POLYCARBONATE CAB SAFETY WINDOW KIT

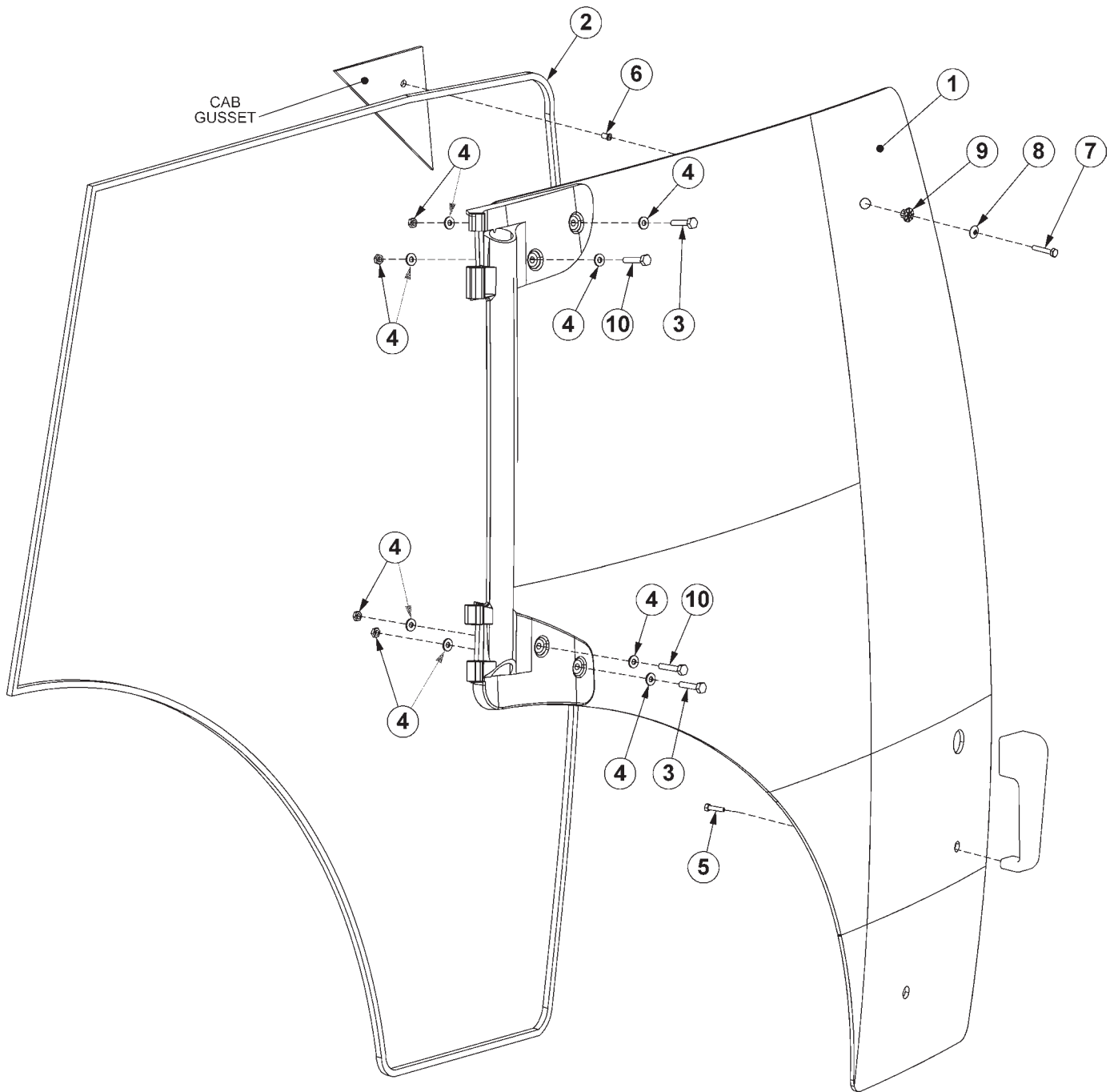

ITEM	PART NO.	QTY.	DESCRIPTION
1	06490004	1	POLYCARBONATE, NHTSA 115, DOOR, RH
2	31965	17'	TRIM SEAL, 3/8 CLIP X 3/4 OD BULB
3	06530502	2	CAPSCREW 8 MM X 40 MM GR8
4	*	*	EXISTING HARDWARE
5	06530501	1	CAPSCREW 6 MM X 25 MM GR8
6	06537006	1	THREADED INSERT 1/4 X 1/2 NC
7	21532	1	CAPSCREW, 1/4X1-1/2 NC
8	06537001	1	WASHER RUBBERIZED
9	35234	1	GROMET, RIBBED 1/2 OD X 1/4 ID X 1/2
10	6T2494	2	CAPSCREW 8 MM X 45 MM GR8
*	06537005	1	ADHESIVE, WTHR STRP (NOT SHOWN)

NON-CAB STEEL CANOPY - OPTIONAL

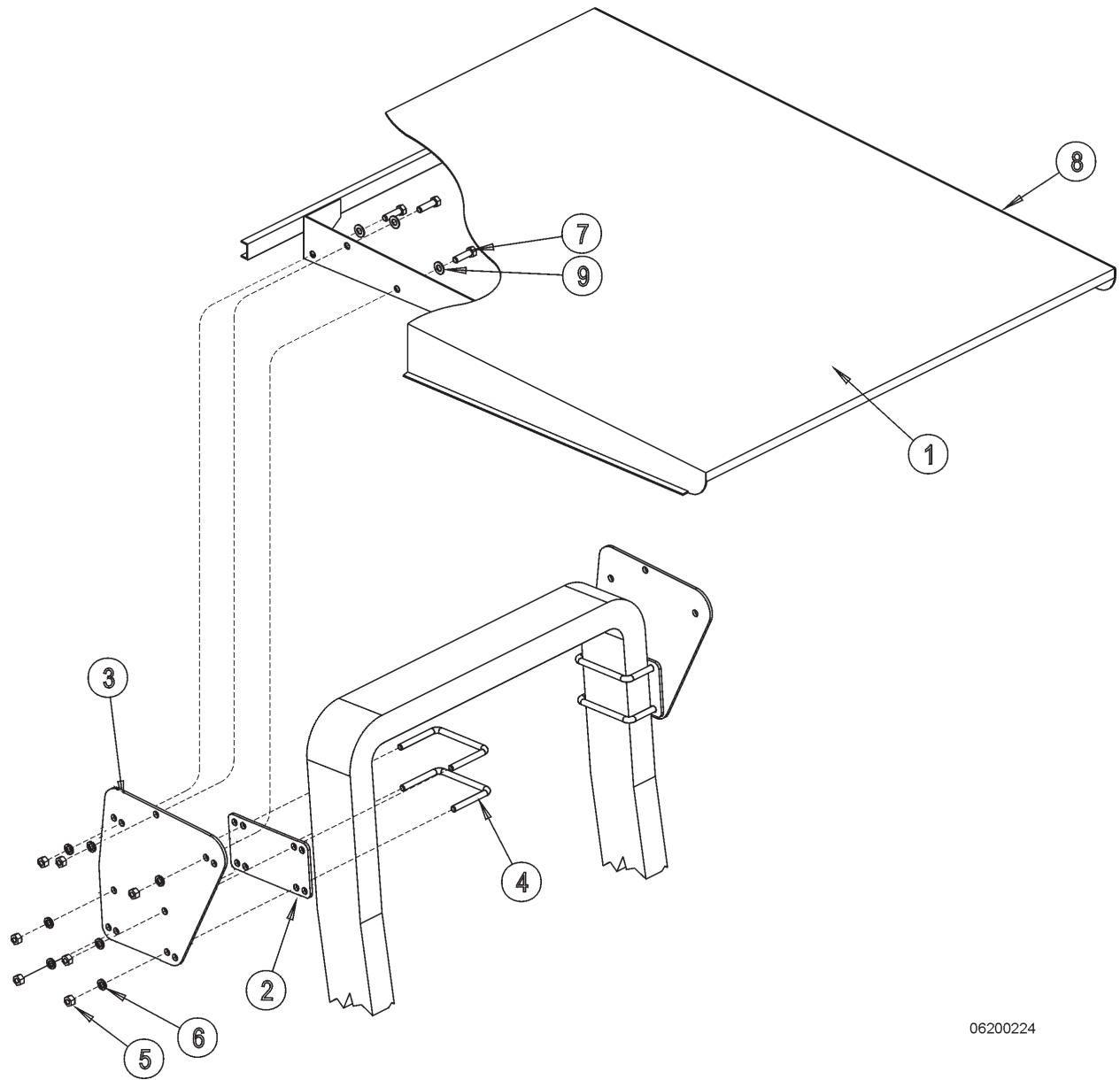

06200224

ITEM	PART NO.	QTY.	DESCRIPTION
1	6T6902	1	CANOPY
2	32730	2	SPACER CANOPY BRACKET
3	32727	2	CANOPY BRACKET
4	0642003	4	U-BOLT,3.25x5.00x.50,20NF,GR8
5	21700	14	HEX NUT - 1/2" NF
6	21990	14	LOCKWASHER - 1/2"
7	21730	6	CAPSCREW - 1/2" X 1 1/4"
8	28053	4.8'	TRIM-LOCK
9	22018	6	FLATWASHER - 1/2" WIDE

EXHAUST MOUNT

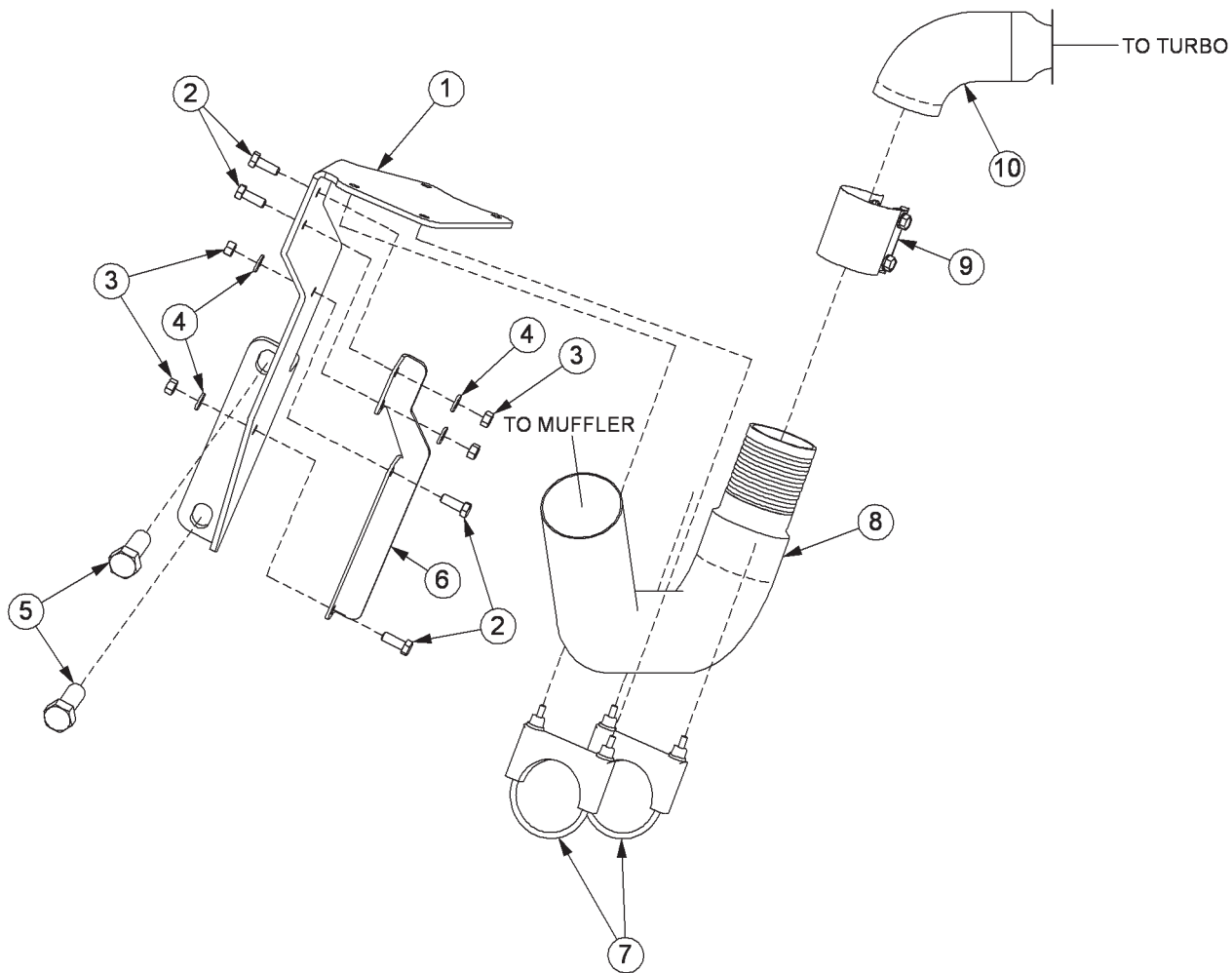

ITEM	PART NO.	QTY.	DESCRIPTION
1	06410127	1	MNT,EXHAUST,TSA100-110
2	21630	4	CAPSCREW,3/8 x 1,NC
3	21625	4	HEX NUT,3/8,NC
4	21988	4	LOCKWASHER,3/8
5	*	2	EXISTING MAINFRAME HARDWARE
6	06410128	1	MNT,EXHAUST,SUPPORT
7	35188	2	CLAMP,EXHAUST,3"
8	06520024	1	TUBE,EXHAUST,SUPPORT,4CYL
9	06520035	1	CLAMP,EXHAUST,2.75,SS,WRAP
10	*	REF	EXHAUST TUBE (CUT)

OPTIONAL PUMP AND GRILL GUARD KIT

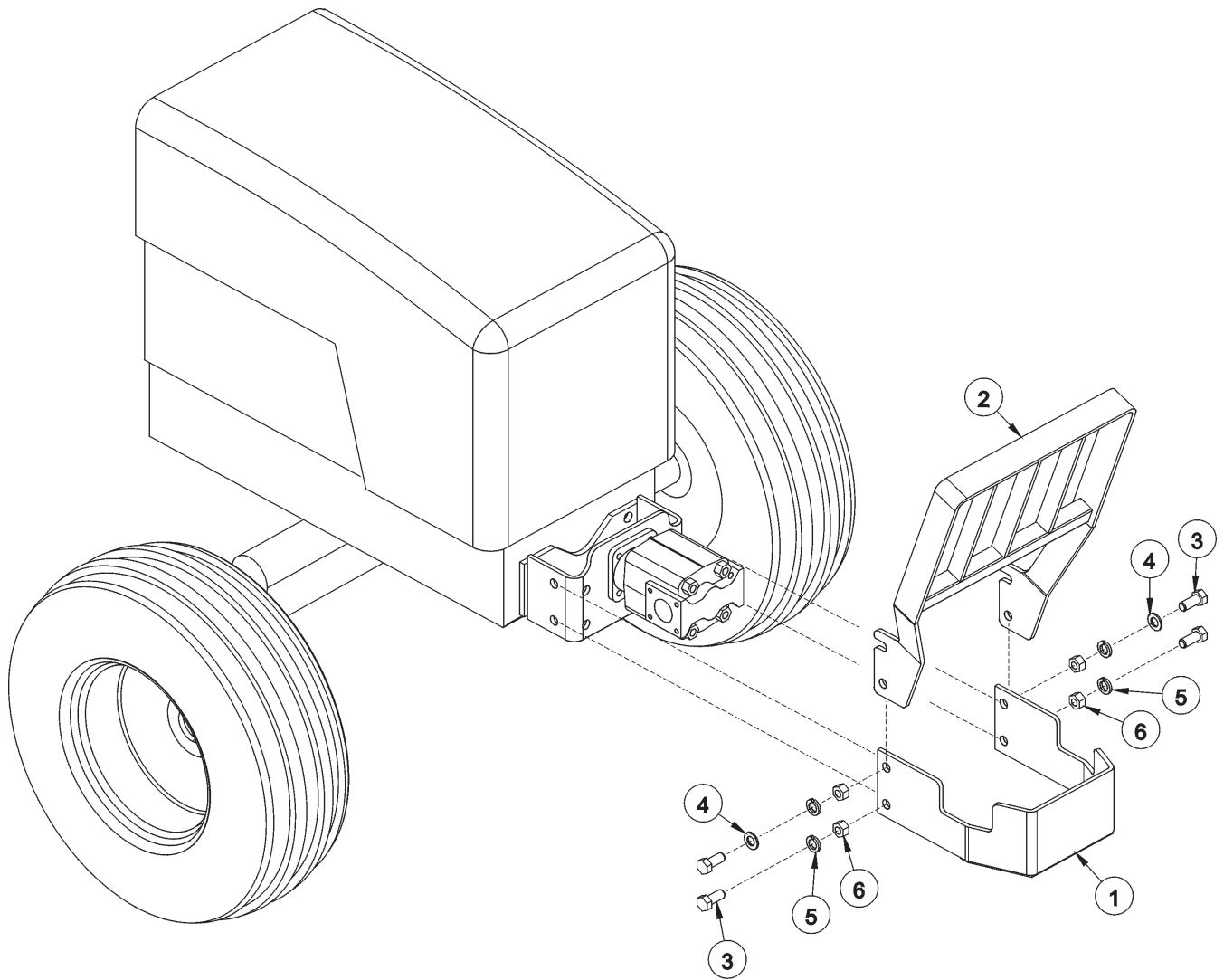

06200349

ITEM	PART NO.	QTY.	DESCRIPTION
1	32430	1	UNIVERSAL PUMP GUARD
2	32737	1	UNIVERSAL GRILL GUARD
3	21833	4	CAPSCREW - 3/4 X 2 1/4
4	22021	2	FLATWASHER - 3/4
5	21993	4	LOCKWASHER - 3/4
6	21825	4	HEX NUT - 3/4

BRAKE VALVE SOLENOID

NOTE:

CAUTION - TORQUE COIL NUT TO 5 Ft. Lbs. MAXIMUM. DO NOT OVER TORQUE NUT, DAMAGE TO CARTRIDGE OR COIL WILL OCCUR.

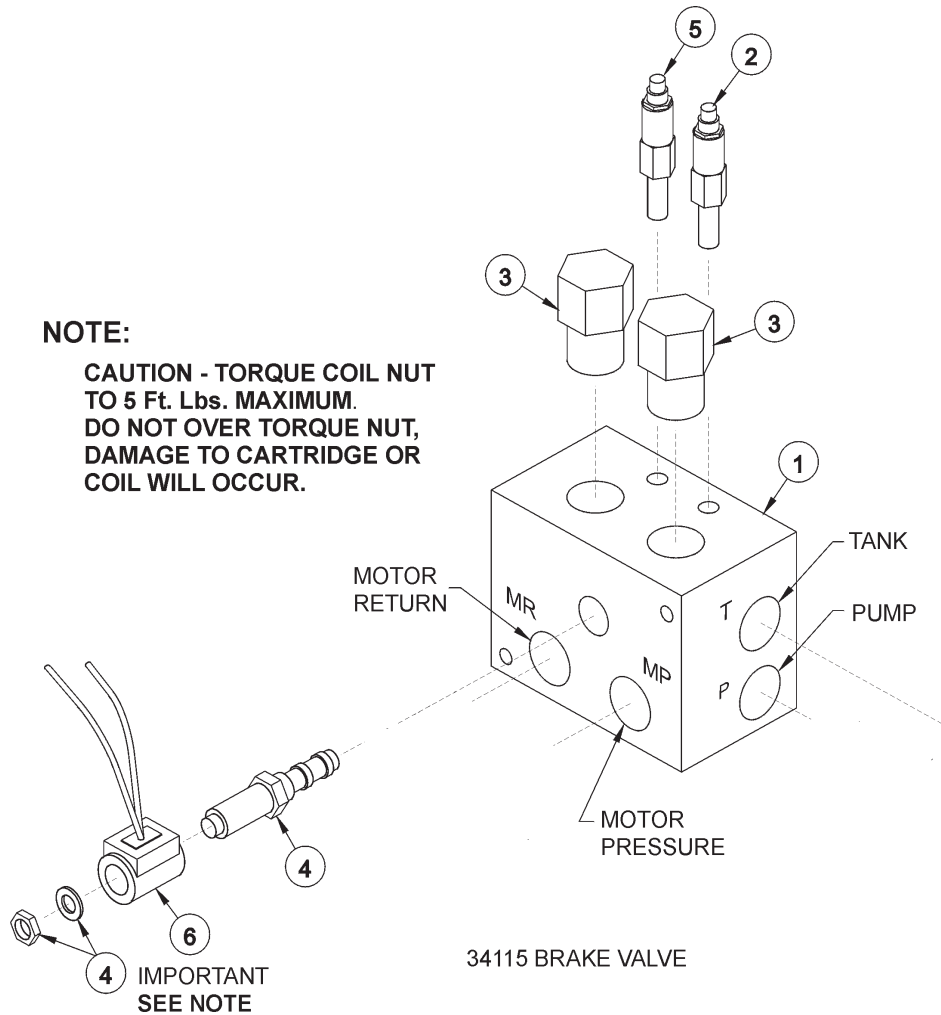

ITEM	PART NO.	QTY.	DESCRIPTION
*	34115	AVAIL	SOLENOID BRAKE VALVE ASSEMBLY - HIGH PRESSURE
1	34092	1	BRAKE VALE, BLANK
2	34095	1	RELIEF VALVE, 3000 PSI
3	34094	2	LOGICELEMENT
4	34093	1	SOLENOID, 2 POSITION, 3 WAY
5	34091	1	RELIEF VALVE, 2600 PSI
**	34096	2	RELIEF SEAL KIT
**	34097	1	SOLENOID SEAL KIT
**	34098	2	ELEMENT SEAL KIT
7	33555	2	ADAPTER 1" MORB x 1" MJIC
8	33554	1	ELBOW 1" MORB x 1" MJIC 45°
9	34117	1	ELBOW 1" MORB x 1" MJIC 90°

SOLENOID VALVE SWITCH AND WIRING

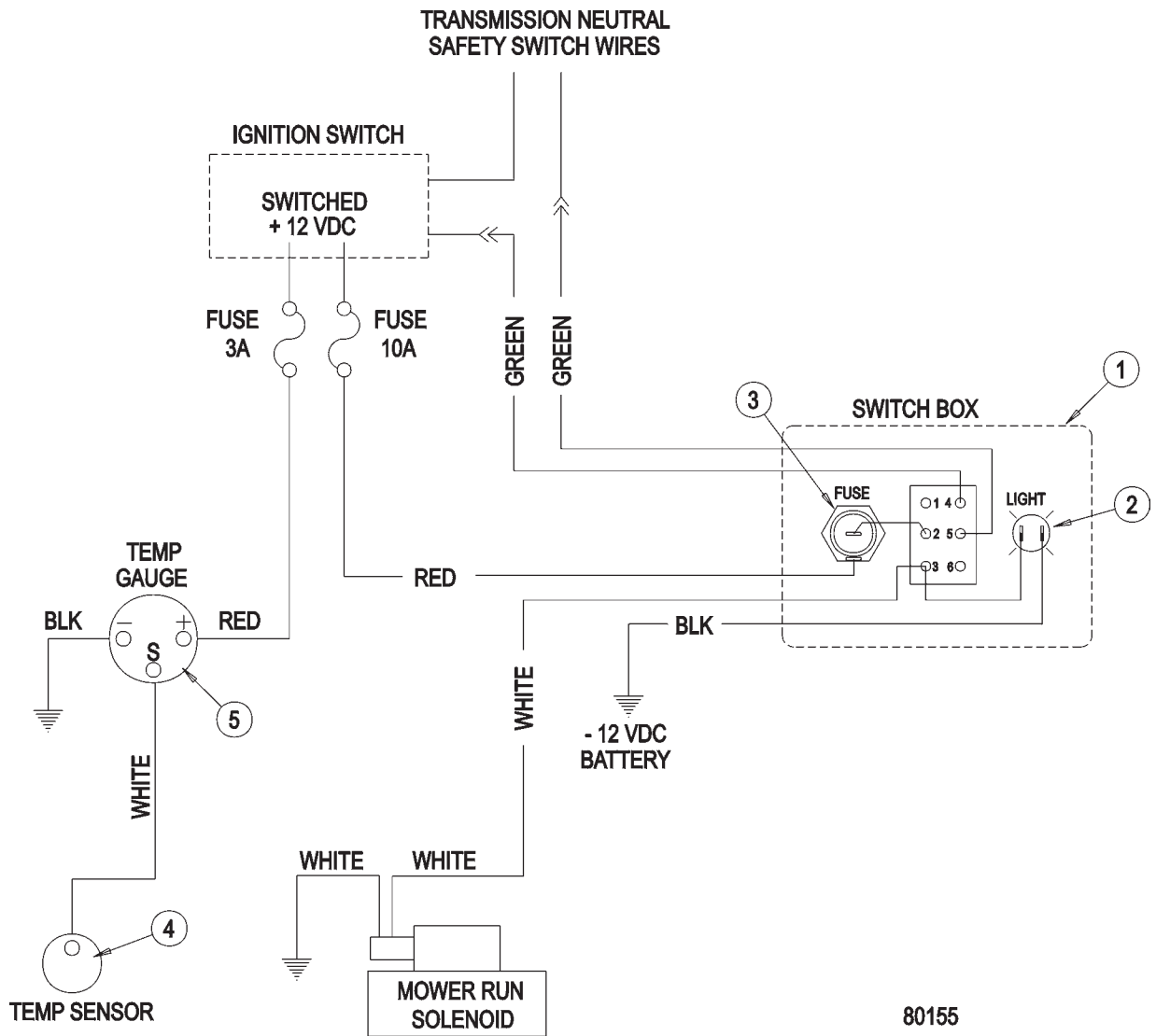

ITEM	PART NO.	QTY.	DESCRIPTION
	27401	AVAIL.	SWITCH ASSEMBLY
1	31301	1	SWITCH BOX
2	6T3923	1	SWITCH "ON" LIGHT
3	6T3924	1	FUSE HOLDER
4	6T3931	OPT.	TEMPERATURE SENSOR
5	6T3934	OPT.	OIL TEMPERATURE GAUGE

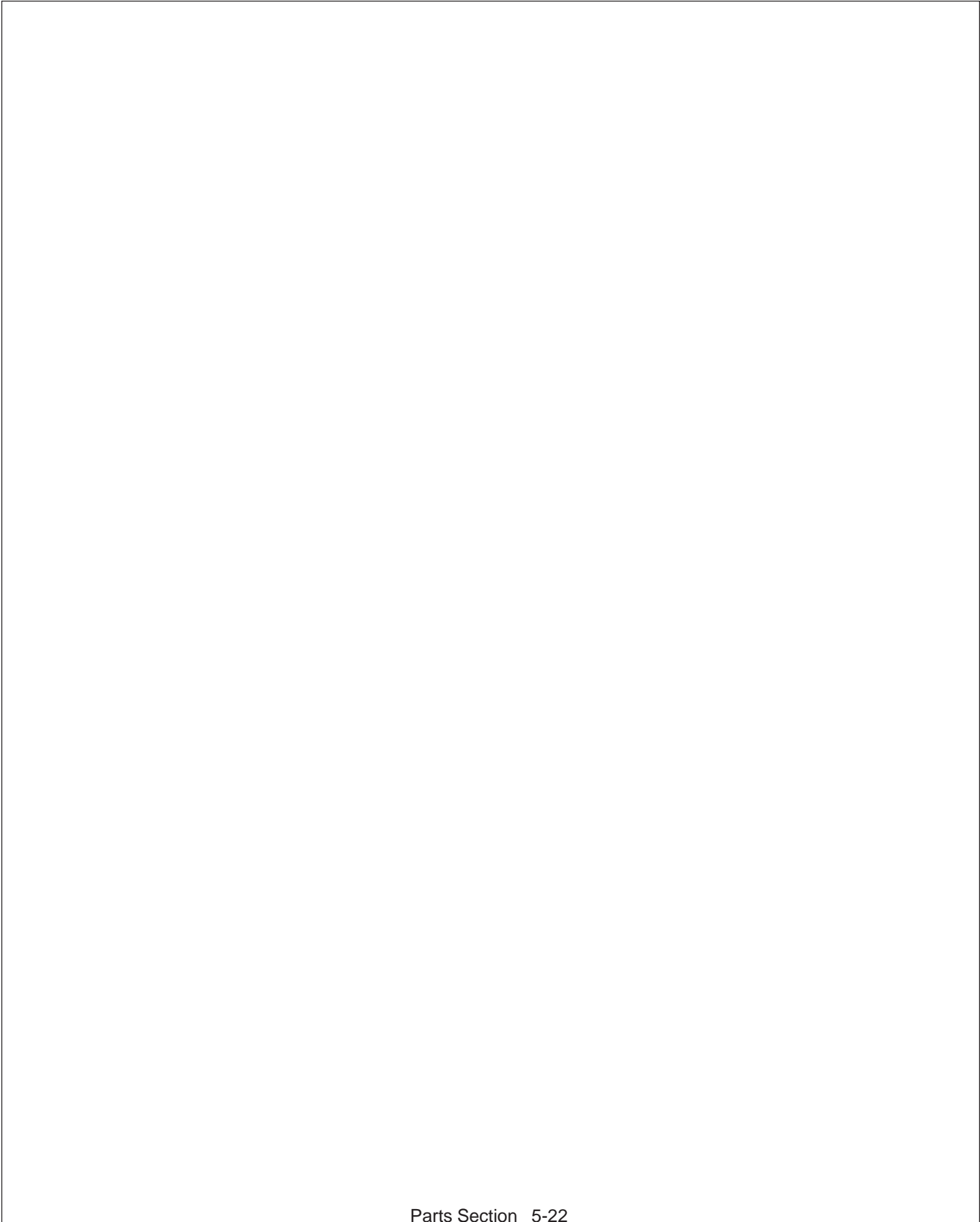

HEAVY DUTY SIDE FLAIL MOWER

COMMON PARTS SECTION

TABLE OF CONTENTS

SECTION	ASSEMBLY	PAGE
CABLE LIFT ASSEMBLY		6-4
COMBO DRAFT BEAM		6-6
60" STANDARD ROTATION - COMBO		6-8
60" REVERSE ROTATION - COMBO		6-10
75" STANDARD ROTATION - CABLE		6-12
75" REVERSE ROTATION - CABLE		6-14
75" STANDARD ROTATION - COMBO		6-16
75" REVERSE ROTATION - COMBO		6-18
90" STANDARD ROTATION - CABLE		6-20
90" REVERSE ROTATION - CABLE		6-22
90" STANDARD ROTATION - COMBO		6-24
90" REVERSE ROTATION - COMBO		6-26
SIDE FLAIL DRIVE ASSY - COMBO		6-28
SIDE FLAIL DRIVE ASSY - CABLE		6-30
CABLE LIFT ARM ASSY		6-32
HYDRAULIC LIFT CYLINDERS		6-34
RESERVOIR TANK FILTER ASSEMBLY		6-38
HUSCO VALVES BREAKDOWN		6-40
FRONT HYDRAULIC PUMP		6-54
FLAIL MOTOR - HIGH PRESSURE		6-56
COOLER ASSEMBLY		6-58
SOLENOID BRAKE VALVE ASSEMBLY		6-60
SOLENOID BRAKE VALVE HYDRO SCHEMATIC		6-61
SIDE FLAIL TRAVEL LOCK		6-62
TRAVEL LOCK LIFT BEAM		6-63
SWITCHBOX		

PARTS ORDERING GUIDE

The following instructions are offered to help eliminate needless delay and error in processing purchase orders for the equipment in this manual.

1. The Parts Section is prepared in logical sequence and grouping of parts that belong to the basic machine featured in this manual. Part Numbers and Descriptions are given to help locate the parts and quantities required.

2. The Purchase Order must indicate the **Name and Address** of the person or organization ordering the parts, **who should be charged**, and if possible, the **serial number of the machine** for which the parts are being ordered.

3. The purchase order must clearly list the **quantity of each part**, the complete and correct **part number**, and the basic **name of the part**.

4. The manufacturer reserves the right to substitute parts where applicable.

5. Some parts may be unlisted items which are special production items not normally stocked and are subject to special handling. Request a quotation for such parts before sending a purchase order.

6. The manufacturer reserves the right to change prices without prior notice.

NOTE: When ordering replacement decals, refer to the part numbers and descriptions listed in the safety section in the front of this manual.



1000

For maximum safety and to guarantee optimum product reliability, always use genuine **Tiger** replacement parts. The use of inferior replacement parts may cause premature or catastrophic failure which could result in serious injury or death.

Direct any questions regarding parts to:

Tiger Corporation
3301 N. Louise Ave.
Sioux Falls, SD 57107
1-800-843-6849
1-605-336-7900

CABLE LIFT ASSEMBLY

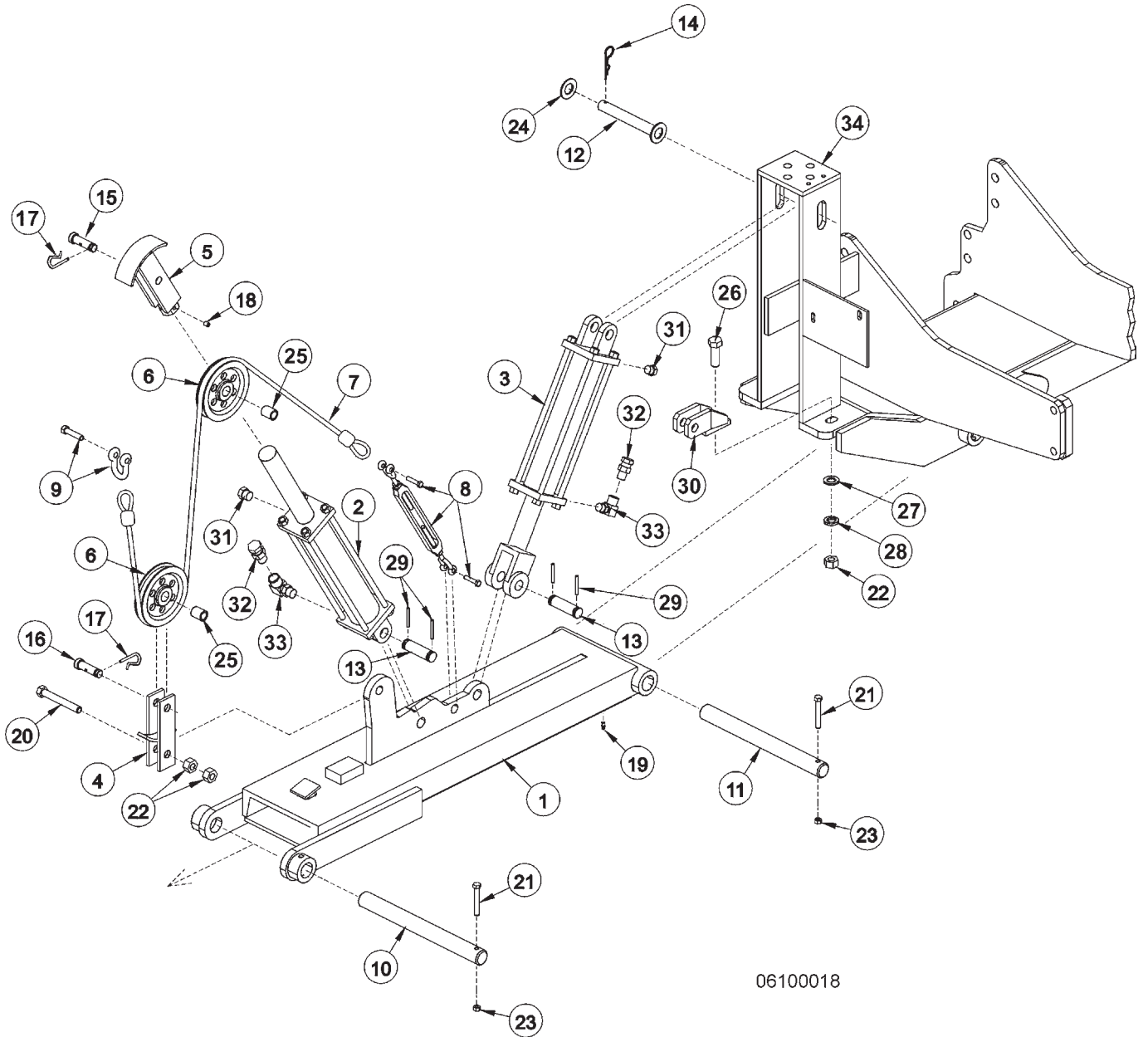

06100018

CABLE LIFT ASSEMBLY

ITEM	PART NO.	QTY.	DESCRIPTION
1	6T0103E	OPT.	DRAFT BEAM (EXTENDED 6" 4WD)
	6T0105	OPT.	DRAFT BEAM (STD WITH TRAVEL LOCK)
	6T0108	OPT.	DRAFT BEAM (30 LB CHANNEL, 45 3/8")
2	6T0150	1	CYLINDER 3" X 18"
3	6T0151R	1	HYD. CYLINDER 3" X 10"
4	6T0100	1	LOWER SHEAVE BRACKET
5	6T0101	1	UPPER SHEAVE BRACKET
6	33768	2	SHEAVE
7	6T0110	1	LIFT CABLE (STD 1/2" X 87 1/2")
	6T0110E	OPT.	LIFT CABLE (EXTENDED 6" 4WD)
	6T0110L	OPT.	LIFT CABLE (EXTENDED 15")
8	6T0115	1	TURN BUCKLE
9	6T0112	1	SHACKLE WITH PIN
10	6T2999	1	OUTER DRAFT BEAM PIN 1 1/2" X 14 1/2"
11	6T3001	1	INNER DRAFT BEAM PIN 1 1/2" X 15 3/4"
12	6T3005	1	CYLINDER PIN 1" X 6 5/8"
13	TB1033	2	CLEVIS PIN 1" X 4"
14	6T3004	1	R - CLIP 3/16"
15	6T3010	1	UPPER SHEAVE PIN WITH ZERK 3/4" X 3"
16	6T3009	1	LOWER SHEAVE PIN WITH ZERK 3/4" X 2 1/2"
17	6T3020	2	R - CLIP 5/32"
18	6T2272	1	SET SCREW 3/8" X 1/2"
19	6T3211	1	GREASE ZERK 1/8" STRAIGHT
20	21837	1	CAPSCREW 3/4" X 3 1/4"
21	21688	2	CAPSCREW 7/16" X 3 1/4"
22	21825	2	HEX NUT 3/4"
23	21677	2	NYLOCK NUT 7/16"
24	22023	1	FLAT WASHER 1"
25	21989	2	LOCK WASHER 7/16"
26	6T0104N	2	SHEAVE PIN BUSHING 1" OD X 3/4" ID
27	21833	1	CAPSCREW 3/4" X 2 1/4"
28	22021	1	FLAT WASHER 3/4"
29	21993	1	LOCK WASHER 3/4"
30	06537021	4	ROLL PIN
31	6T0106	1	TRAVEL LOCK BRACKET
32	6T4258	2	BREATHER 1/2"
33	34396	2	RESTRICTOR
34	34244	2	ELBOW FITTING 1/2"
35	06700095	1	SPACER
37	*	REF.	MAIN FRAME REFER TO TRACTOR PARTS SECTION

COMBO DRAFT BEAM

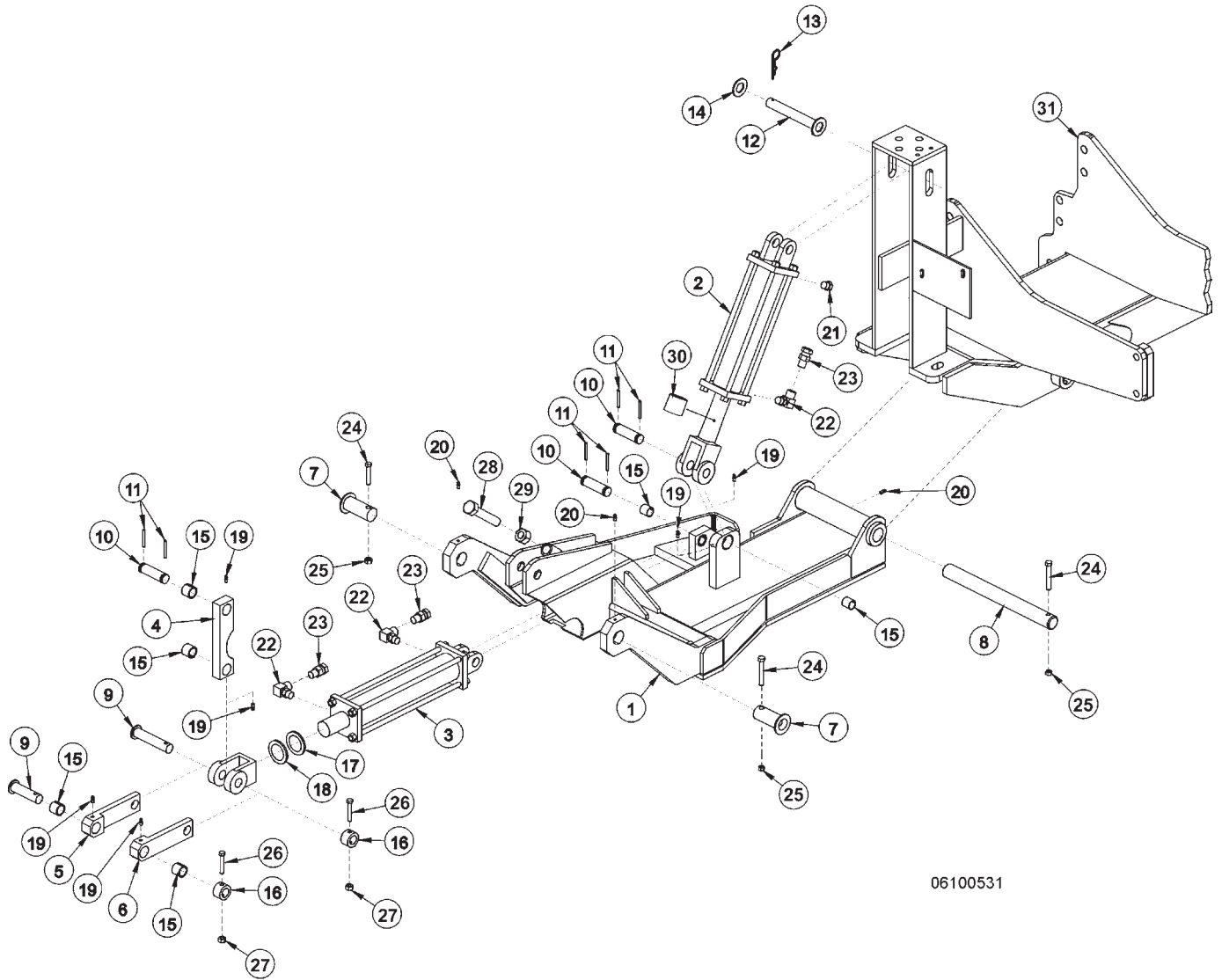

06100531

COMBO DRAFT BEAM

ITEM	PART NO.	QTY.	DESCRIPTION
1	28955D	1	COMBO DRAFT BEAM -HVY DTY FLAIL
2	6T0151R	1	HYD. CYLINDER 3" X 10"
3	25343	1	HYD. CYLINDER 3" X 12" - HVY DTY
4	TF4500A	1	PIVOT ARM
5	TF4507B	1	RIGHT LINKAGE ARM
6	TF4506B	1	LEFT LINKAGE ARM
7	TF4514A	2	PIN, HEAD PIVOT
8	6T3001	1	PIN, BEAM PIVOT
9	TF4519	2	PIN, LINKAGE
10	TB1033	3	PIN, CLEVIS
11	06537021	6	ROLLPIN
12	6T3005	1	PIN, 1" W/ CAP
13	6T3004	1	R-CLIP HAIRPIN
14	6T2614	1	FLATWASHER 1"
15	TB3010	8	BUSHING 1"
16	22847	2	BOSS, LINKAGE PIN
17	22076	1	SPACER, HYD. CYLINDER 1/4"
18	22077	1	SPACER, HYD. CYLINDER 5/16"
19	6T3207	6	GREASE ZERK 1/4"
20	6T3211	3	GREASE ZERK 1/8"
21	6T4258	1	BREATHER 1/2"
22	34244	3	ELBOW FITTING 1/2"
23	34396	3	SWIVEL RESTRICTOR
24	21688	3	CAPSCREW 7/16" X 3 1/4"
25	21677	3	NYLOCK NUT 7/16"
26	21635	2	CAPSCREW 3/8" X 2 1/4"
27	21625	2	HEX NUT 3/8"
28	21831	1	CAPSCREW 3/4" X 1 3/4"
29	21825	1	HEX NUT 3/4"
30	06700095	1	CYLINDER SPACER W/SET SCREW
31	*	REF	REFER TO MAIN FRAME

NOTES:

1. ITEM 30 IS USED ON THE GLAND END OF ITEM 2 (AS NEEDED)
2. ORIENTATION OF ITEMS 4,5 & 6 ARE CRITICAL

60" SIDE FLAIL, STANDARD ROTATION - COMBO

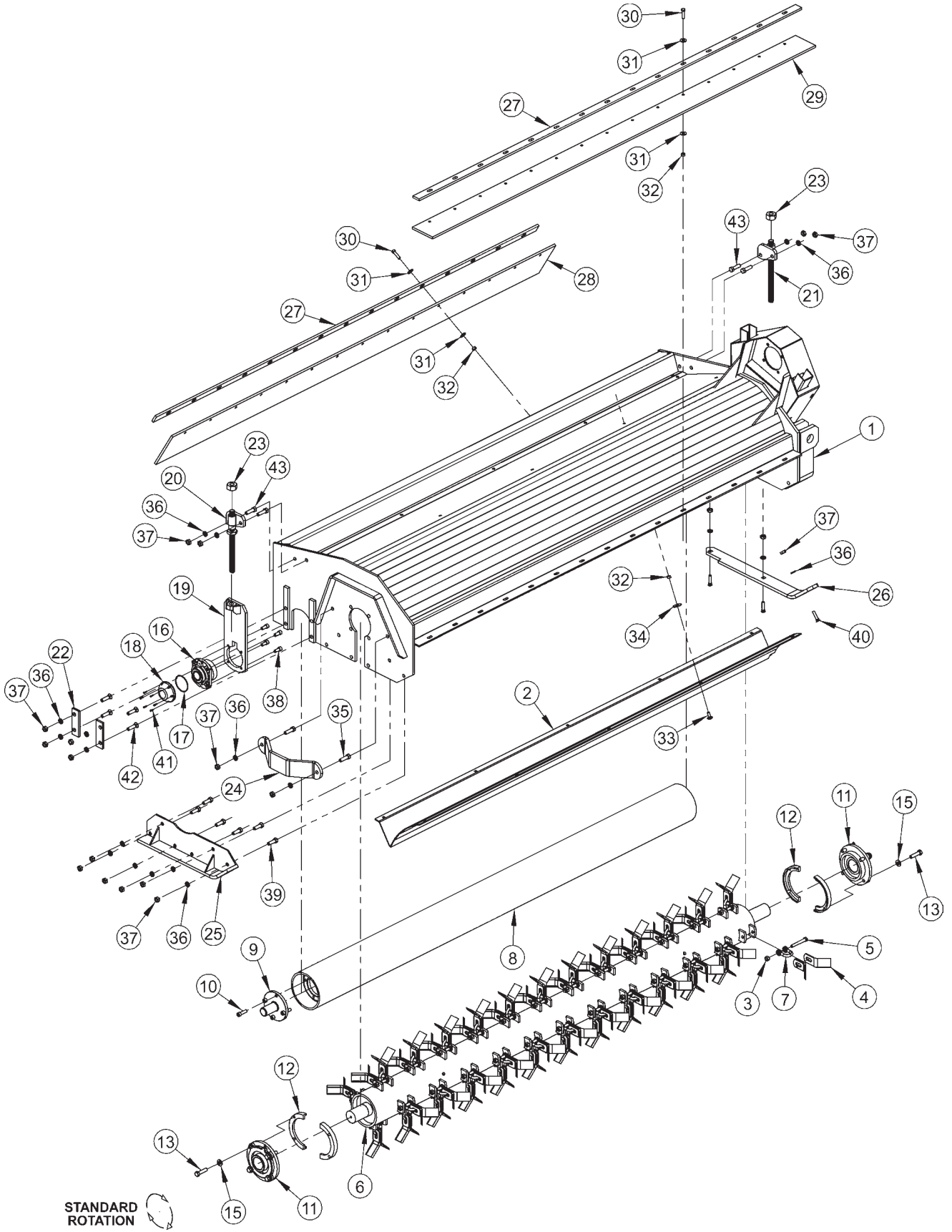

Side Flail Heavy Duty Common Section 6-8

60" SIDE FLAIL, STANDARD ROTATION - COMBO

ITEM	P/N	QTY	DESCRIPTION
1	33913	1	BONNET 60" COMBO
2	TF1802A	1	BAFFLE,FLAIL,60" HD,STC
	TF1807A	1	CUTTERSHAFT,ASSY,60" HD,STC
3	21677	32	NYLOCK NUT,7/16 NC
4	33714	64	KNIFE,FLAIL,STANDARD
5	34011	32	CAPSCREW,7/16x3 7/16,NC GR8
6	TF1807	1	CUTTERSHAFT,60" HD
7	TF1020	32	KNIFE MTG CLEVIS,FLAIL
8	30277	1	GROUND ROLLER 60"
9	TF1045B	2	STUB SHAFT,GROUND ROLLER
10	6T2330	8	CAPSCREW,SKT HD,7/16X1-1/2NC
11	TF1018	2	BEARING,FLANGE,2-3/16
	06200347	*	STRING GUARD,KIT,HD(ITEMS 12,13,15)
12	31204	2	STRING GUARD, HD
13	06530217	8	CAPSCREW,1/2 X 2,NC,L9
15	06533006	12	FLATWASHER,1/2,SAE,L9
16	06520028	2	BEARING,FLANGE,1 3/8,GRNDRLR
17	06520029	2	O-RING,2 3/4x3/32,AS568A-148
18	06520027	2	CAP,BEARING,GRNDRLR
19	TF4333A	2	GROUND ROLLER ADJ,BRKT
20	TF4334	1	ROD,GROUND ROLLER ADJ,RT
21	TF4335	1	ROD,GROUND ROLLER ADJ,LF
22	TF4336	4	PLATE,GROUND ROLLER LOCK
23	21399	2	HEX NUT,3/4 (ACME) BULK
24	TF1040	1	GUARD,CUTTER SHAFT
25	TF4371	1	SKID SHOE,L/PROFILE-OUTER
26	23272A	1	SKID SHOE,T3F,INNER
27	TF1803	2	BAR,FLAP,TSF/TRF 60
28	TF1804	1	FLAP,DEFLECTOR,TSF 60
29	06520240	1	FLAP,60",FRONT
30	21632	30	CAPSCREW,3/8 X 1-1/2 NC
31	22016	60	FLATWASHER,3/8
32	21625	40	HEX NUT,3/8 NC
33	6T2283	10	CARRIAGE BOLT,3/8 X 1 NC
34	6T2615	10	WASHER,FENDER 3/8
35	21732	2	CAPSCREW,1/2 X 1-3/4 NC
36	21990	23	LOCKWASHER,1/2
37	21725	23	HEX NUT,1/2 NC
38	6T2331	8	CAPSCREW,SKT HD,7/16 X 1 NC
39	21730	6	CAPSCREW,1/2 X 1-1/4 NC
40	23293	3	PLOW,BOLT,1/2 X 1-3/4 NC
41	06530001	12	CAPSCREW,SKT HD,8-32x1/2,SS
42	6T2291	8	PLOW BOLT,1/2 X 2 NC GR5
43	21731	4	CAPSCREW,1/2 X 1-1/2 NC

60" SIDE FLAIL, REVERSE ROTATION - COMBO

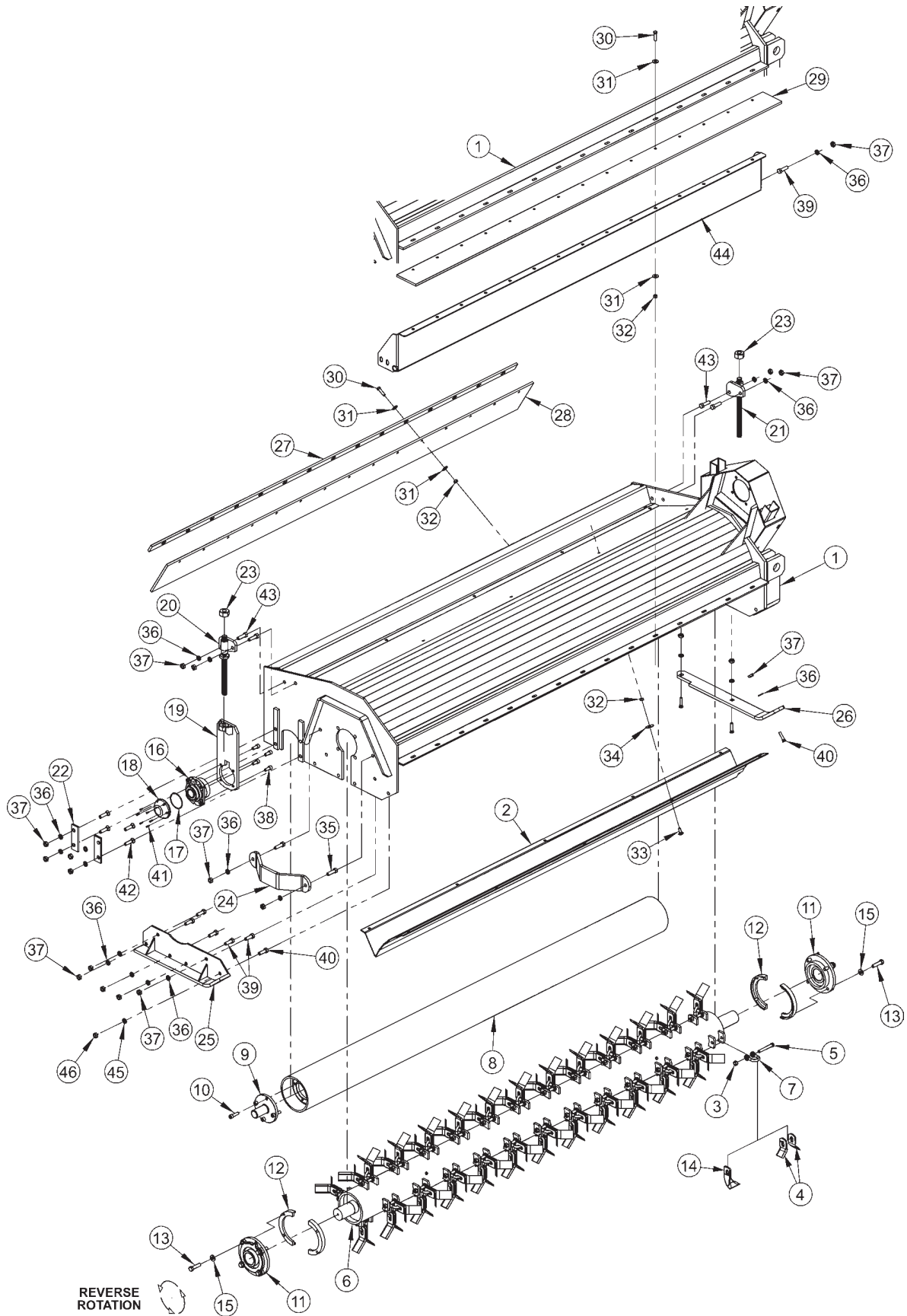

Side Flail Heavy Duty Common Section 6-10

60" SIDE FLAIL, REVERSE ROTATION - COMBO

ITEM	P/N	QTY	DESCRIPTION
1	33913	1	BONNET 60" COMBO
2	TF1802A	1	BAFFLE,FLAIL,60" HD,STC
	TF1807A	1	CUTTERSHAFT,ASSY,60" HD,STC
3	21677	32	NYLOCK NUT,7/16 NC
4	33714	64	KNIFE,FLAIL,STANDARD
5	34011	32	CAPSCREW,7/16x3 7/16,NC GR8
6	TF1807	1	CUTTERSHAFT,60" HD
7	TF1020	32	KNIFE MTG CLEVIS,FLAIL
8	30277	1	GROUND ROLLER 60"
9	TF1045B	2	STUB SHAFT,GROUND ROLLER
10	6T2330	8	CAPSCREW,SKT HD,7/16X1-1/2NC
11	TF1018	2	BEARING,FLANGE,2-3/16
	06200347	*	STRING GUARD,KIT,HD(ITEMS 12,13,15)
12	31204	2	STRING GUARD, HD
13	06530217	8	CAPSCREW,1/2 X 2,NC,L9
14	TF1019F	32	KNIFE,FLAIL (SMOOTH CUT)
15	06533006	12	FLATWASHER,1/2,SAE,L9
16	06520028	2	BEARING,FLANGE,1 3/8,GRNDRLR
17	06520029	2	O-RING,2 3/4x3/32,AS568A-148
18	06520027	2	CAP,BEARING,GRNDRLR
19	TF4333A	2	GROUND ROLLER ADJ,BRKT
20	TF4334	1	ROD,GROUND ROLLER ADJ,RT
21	TF4335	1	ROD,GROUND ROLLER ADJ,LF
22	TF4336	4	PLATE,GROUND ROLLER LOCK
23	21399	2	HEX NUT,3/4 (ACME) BULK
24	TF1040	1	GUARD,CUTTER SHAFT
25	TF4371	1	SKID SHOE,L/PROFILE-OUTER
26	23272A	1	SKID SHOE,T3F,INNER
27	TF1803	1	BAR,FLAP,TSF/TRF 60
28	TF1804	1	FLAP,DEFLECTOR,TSF 60
29	06520240	1	FLAP,60",FRONT
30	21632	30	CAPSCREW,3/8 X 1-1/2 NC
31	22016	60	FLATWASHER,3/8
32	21625	40	HEX NUT,3/8 NC
33	6T2283	10	CARRIAGE BOLT,3/8 X 1 NC
34	6T2615	10	WASHER,FENDER 3/8
35	21732	2	CAPSCREW,1/2 X 1-3/4 NC
36	21990	23	LOCKWASHER,1/2
37	21725	23	HEX NUT,1/2 NC
38	6T2331	8	CAPSCREW,SKT HD,7/16 X 1 NC
39	21730	6	CAPSCREW,1/2 X 1-1/4 NC
40	23293	3	PLOW,BOLT,1/2 X 1-3/4 NC
41	06530001	12	CAPSCREW,SKT HD,8-32x1/2,SS
42	6T2291	8	PLOW BOLT,1/2 X 2 NC GR5
43	21731	4	CAPSCREW,1/2 X 1-1/2 NC
44	TF1801	1	TRASH GUARD,60REV ROT-HD
45	22018	1	FLATWASHER,1/2,WIDE
46	21727	1	NYLOCK NUT,1/2 NC

75" SIDE FLAIL, STANDARD ROTATION - CABLE

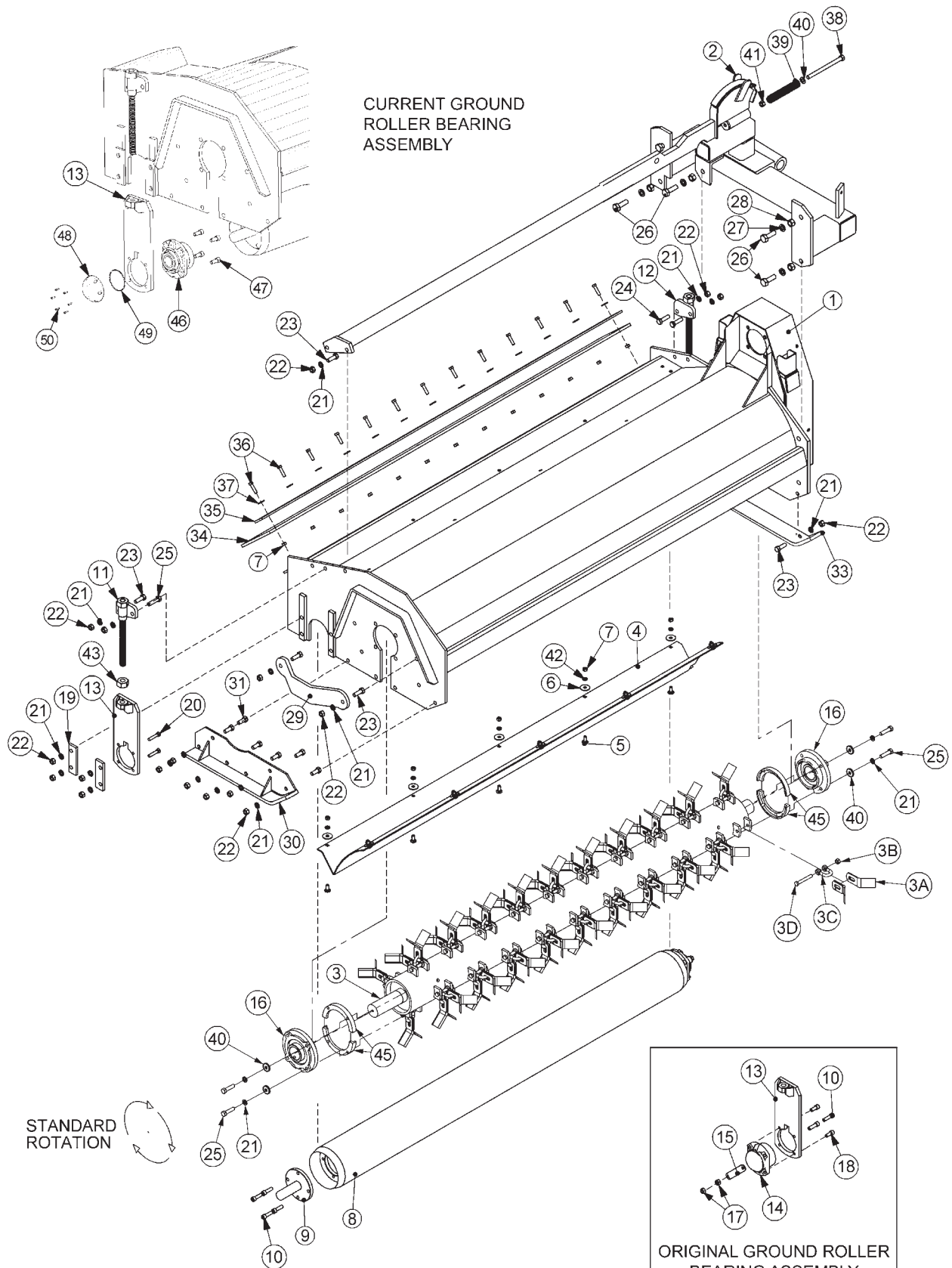

33076

Side Flail Heavy Duty Common Section 6-12

75" SIDE FLAIL, STANDARD ROTATION - CABLE

ITEM	P/N	QTY	DESCRIPTION
1	22032	1	BONNET,75,HD,TSF
2	21298C	1	MOUNTING FRAME
3	TF1002A	1	CUTTERSHAFT,ASSY,75" HD,STC
3A	33714	80	KNIFE,FLAIL,STANDARD
3B	21677	40	NYLOCK NUT,7/16" NC
3C	TF1020	40	KNIFE MTG CLEVIS,FLAIL
3D	34011	40	KNIFE MTG BOLT,FLAIL
4	TF1402A	1	BAFFLE,FLAIL,75" HD,STC
5	6T2283	10	CARRIAGE BOLT,3/8" X 1"NC
6	6T2615	10	WASHER,FENDER 3/8"
7	21625	23	HEX NUT,3/8",NC
8	28738	1	GROUND ROLLER
9	TF1045B	2	GRND ROLLER STUB SHAFT
10	6T2330	12	CAPSCREW, 7/16 x 1 1/2, SOCKET HEAD
11	TF4334	1	ROD,GROUND ROLLER ADJ,RT
12	TF4335	1	ROD,GROUND ROLLER ADJ,LF
13	TF4333A	2	GROUND ROLLER ADJ BRK
14	TF1022S	2	BEARING,FLANGE,1-3/8"
15	30565	2	BEARING CAP KEEPER
16	TF1018	2	BEARING,FLANGE,2-3/16"
17	24701	4	HEX NUT, 7/16" NC (STOVER NUT)
18	6T2331	4	CAPSCREW, 7/16 x 1, SOCKET HEAD
19	TF4336	4	CLAMPING BLOCK, LH
20	6T2291	8	PLOW BOLT,1/2" X 2" NC
21	21990	31	LOCKWASHER, 1/2"
22	21725	23	HEX NUT, 1/2" NC
23	21731	6	CAPSCREW, 1/2 X 1 1/2,NC
24	21732	2	CAPSCREW, 1/2 x 1 3/4,NC
25	21733	9	CAPSCREW, 1/2 x 2,NC
26	21783	5	CAPSCREW, 5/8 x 2,NC
27	21992	5	LOCKWASHER, 5/8
28	21775	5	HEX NUT, 5/8
29	TF1040	1	GUARD, CUTTER SHAFT
30	TF4371	1	SKID SHOE,L/PROFILE - OUTER
31	21730	6	CAPSCREW, 1/2 X 1 1/4,NC
33	TF4365	1	SKID SHOE,L/PROFILE - INNER
34	TF1016	1	FLAP,DEFLECTOR,TSF/TRF 75
35	TF1029	1	FLAP RETAINING BAR
36	21632	13	CAPSCREW,3/8" X 1-1/2" NC
37	22016	13	FLATWASHER,3/8"
38	21745	1	CAPSCREW, 1/2 x 7,NC
39	27005	1	SPRING, PUSHOFF, SIDE RTRY
40	27938	3	BUSHING,MACH,1ODx1/2IDx14GA.
41	21727	1	NYLOCK NUT, 1/2"
42	21988	10	LOCKWASHER, 3/8"
43	21399	2	HEX NUT, 3/4" (ACME THRD)
45	31204	2	STRING GUARD, HD
46	06520028	2	BEARING,FLANGE, 1 3/8"
47	6T2331	8	CAPSCREW, 7/16" X 1", SOCKET HEAD
48	06520027	2	CAP,BEARING, GRND ROLLER
49	06520029	2	O-RING,2 3/4" X 3/32"
50	06530001	12	CAPSCREW, SKT HD

75" SIDE FLAIL, REVERSE ROTATION - CABLE

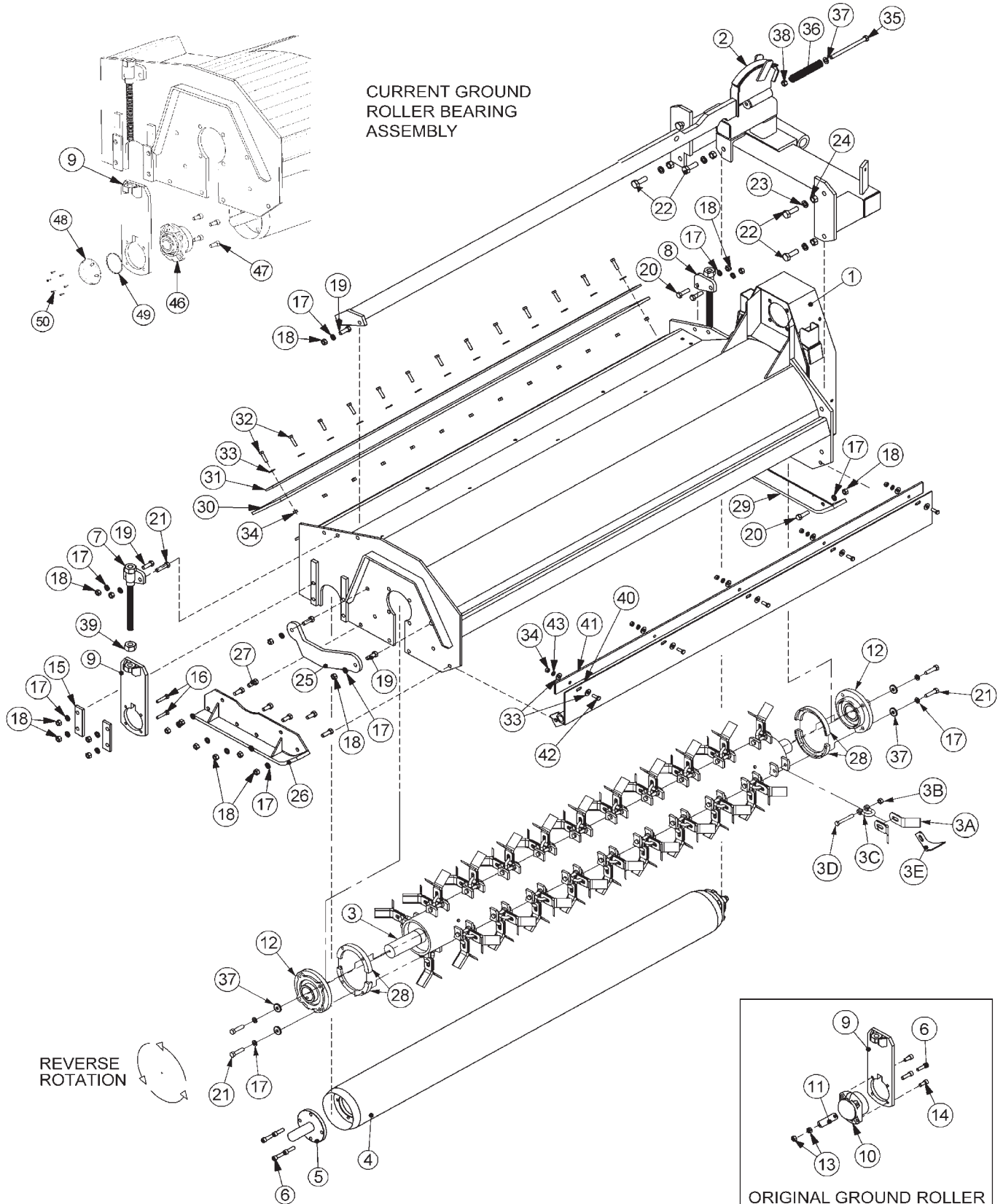

33077

Side Flail Heavy Duty Common Section 6-14

75" SIDE FLAIL, REVERSE ROTATION - CABLE

ITEM	P/N	QTY	DESCRIPTION
1	22032	1	BONNET,75,HD,TSF
2	21298C	1	MOUNTING FRAME
3	TF1002A	1	CUTTERSHAFT,ASSY,75" HD,STC
3A	33714	80	KNIFE,FLAIL,STANDARD
3B	21677	40	NYLOCK NUT,7/16" NC
3C	TF1020	40	KNIFE MTG CLEVIS,FLAIL
3D	34011	40	KNIFE MTG BOLT,FLAIL
3E	TF1019F	40	KNIFE,FLAIL (SMOOTH CUT)
4	28738	1	GROUND ROLLER
5	TF1045B	2	GRND ROLLER STUB SHAFT
6	6T2330	12	CAPSCREW, 7/16 x 1 1/2, SOCKET HEAD
7	TF4334	1	ROD,GROUND ROLLER ADJ,RT
8	TF4335	1	ROD,GROUND ROLLER ADJ,LF
9	TF4333A	2	GROUND ROLLER ADJ BRK
10	TF1022S	2	BEARING,FLANGE,1-3/8"
11	30565	2	BEARING CAP KEEPER
12	TF1018	2	BEARING,FLANGE,2-3/16"
13	24701	4	HEX NUT, 7/16" NC (STOVER NUT)
14	6T2331	4	CAPSCREW, 7/16 x 1, SOCKET HEAD
15	TF4336	4	CLAMPING BLOCK, LH
16	6T2291	8	PLOW BOLT,1/2" X 2" NC
17	21990	31	LOCKWASHER, 1/2"
18	21725	23	HEX NUT, 1/2" NC
19	21731	6	CAPSCREW, 1/2 X 1 1/2,NC
20	21732	3	CAPSCREW, 1/2 x 1 3/4,NC
21	21733	5	CAPSCREW, 1/2 x 2,NC
22	21783	5	CAPSCREW, 5/8 x 2,NC
23	21992	5	LOCKWASHER, 5/8
24	21775	5	HEX NUT, 5/8
25	TF1040	1	GUARD, CUTTER SHAFT
26	TF4371	1	SKID SHOE,L/PROFILE - OUTER
27	21730	5	CAPSCREW, 1/2 X 1 1/4,NC
28	31204	2	STRING GUARD, HD
29	TF4365	1	SKID SHOE,L/PROFILE - INNER
30	TF1016	1	FLAP,DEFLECTOR,TSF/TRF 75
31	TF1029	1	FLAP RETAINING BAR
32	21632	13	CAPSCREW,3/8" X 1-1/2" NC
33	22016	23	FLATWASHER,3/8"
34	21625	18	HEX NUT,3/8",NC
35	21745	1	CAPSCREW, 1/2 x 7,NC
36	27005	1	SPRING, PUSHOFF, SIDE RTRY
37	27938	9	BUSHING,MACH,10Dx1/2IDx14GA.
38	21727	1	NYLOCK NUT, 1/2
39	21399	2	HEX NUT, 3/4" (ACME THRD)
40	TF1403	1	FRONT TRASH GUARD
41	25461	1	MOUNTING BAR
42	21630	5	CAPSCREW, 3/8 x 1,NC
43	21988	5	LOCKWASHER, 3/8"
46	06520028	2	BEARING,FLANGE, 1 3/8"
47	6T2331	8	CAPSCREW, 7/16" X 1", SOCKET HEAD
48	06520027	2	CAP,BEARING, GRND ROLLER
49	06520029	2	O-RING,2 3/4" X 3/32"
50	06530001	12	CAPSCREW, SKT HD

75" SIDE FLAIL, STANDARD ROTATION - COMBO

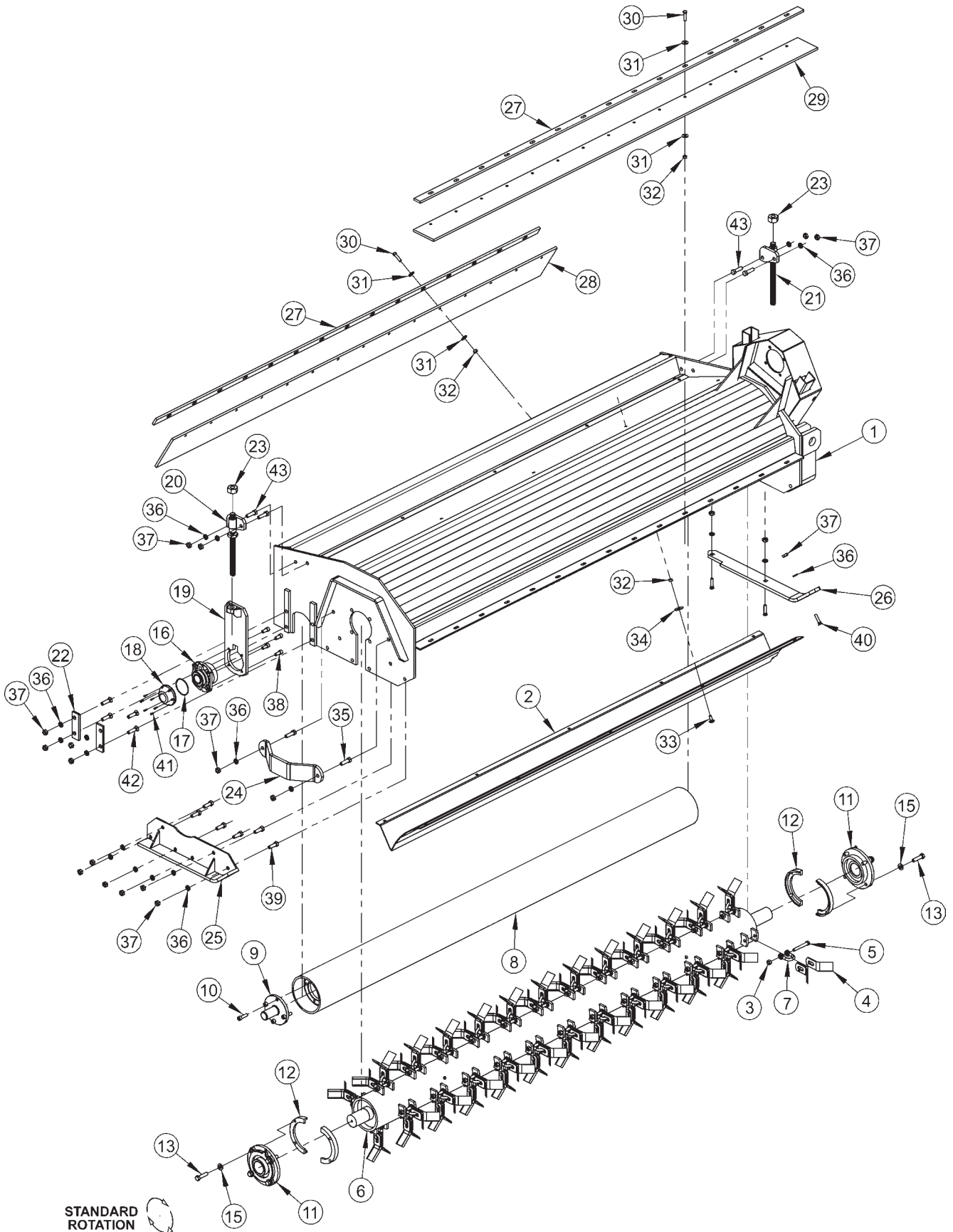

Side Flail Heavy Duty Common Section 6-16

75" SIDE FLAIL, STANDARD ROTATION - COMBO

ITEM	P/N	QTY	DESCRIPTION
1	21499A	1	BONNET,75,HD,T3F,RT
2	TF1402A	1	BAFFLE,FLAIL,75HD,STD ROT
	TF1002A	1	CUTSHFT ASSY,75HD,STD KNIVES
3	21677	40	NYLOCK NUT,7/16 NC
4	33714	80	KNIFE,FLAIL,STANDARD
5	34011	40	CAPSCREW,7/16x3 7/16,NC GR8
6	TF1002	1	CUTTERSHAFT,75,HD
7	TF1020	40	KNIFE MTG CLEVIS,FLAIL
8	28738	1	GROUND ROLLER,75
9	TF1045B	2	STUB SHAFT,GROUND ROLLER
10	6T2330	8	CAPSCREW,SKT HD,7/16X1-1/2NC
11	TF1018	2	BEARING,FLANGE,2-3/16
	06200347	*	STRING GUARD,KIT,HD(ITEMS 12,13,15)
12	31204	2	STRING GUARD, HD
13	06530217	8	CAPSCREW,1/2 X 2,NC,L9
15	06533006	12	FLATWASHER,1/2,SAE,L9
16	06520028	2	BEARING,FLANGE,1 3/8,GRNDRLR
17	06520029	2	O-RING,2 3/4x3/32,AS568A-148
18	06520027	2	CAP,BEARING,GRNDRLR
19	TF4333A	2	GROUND ROLLER ADJ,BRKT
20	TF4334	1	ROD,GROUND ROLLER ADJ,RT
21	TF4335	1	ROD,GROUND ROLLER ADJ,LF
22	TF4336	4	PLATE,GROUND ROLLER LOCK
23	21399	2	HEX NUT,3/4 (ACME) BULK
24	TF1040	1	GUARD,CUTTER SHAFT
25	TF4371	1	SKID SHOE,L/PROFILE-OUTER
26	23272A	1	SKID SHOE,T3F,INNER
27	TF1029	2	BAR,FLAP,TSF/TRF 75
28	TF1016	1	FLAP,DEFLECTOR,TSF/TRF 75
29	06520242	1	FLAP,75",FRONT
30	21632	30	CAPSCREW,3/8 X 1-1/2 NC
31	22016	60	FLATWASHER,3/8
32	21625	40	HEX NUT,3/8 NC
33	6T2283	10	CARRIAGE BOLT,3/8 X 1 NC
34	6T2615	10	WASHER,FENDER 3/8
35	21732	2	CAPSCREW,1/2 X 1-3/4 NC
36	21990	23	LOCKWASHER,1/2
37	21725	23	HEX NUT,1/2 NC
38	6T2331	8	CAPSCREW,SKT HD,7/16 X 1 NC
39	21730	6	CAPSCREW,1/2 X 1-1/4 NC
40	23293	3	PLOW,BOLT,1/2 X 1-3/4 NC
41	06530001	12	CAPSCREW,SKT HD,8-32x1/2,SS
42	6T2291	8	PLOW BOLT,1/2 X 2 NC GR5
43	21731	4	CAPSCREW,1/2 X 1-1/2 NC

75" SIDE FLAIL, REVERSE ROTATION - COMBO

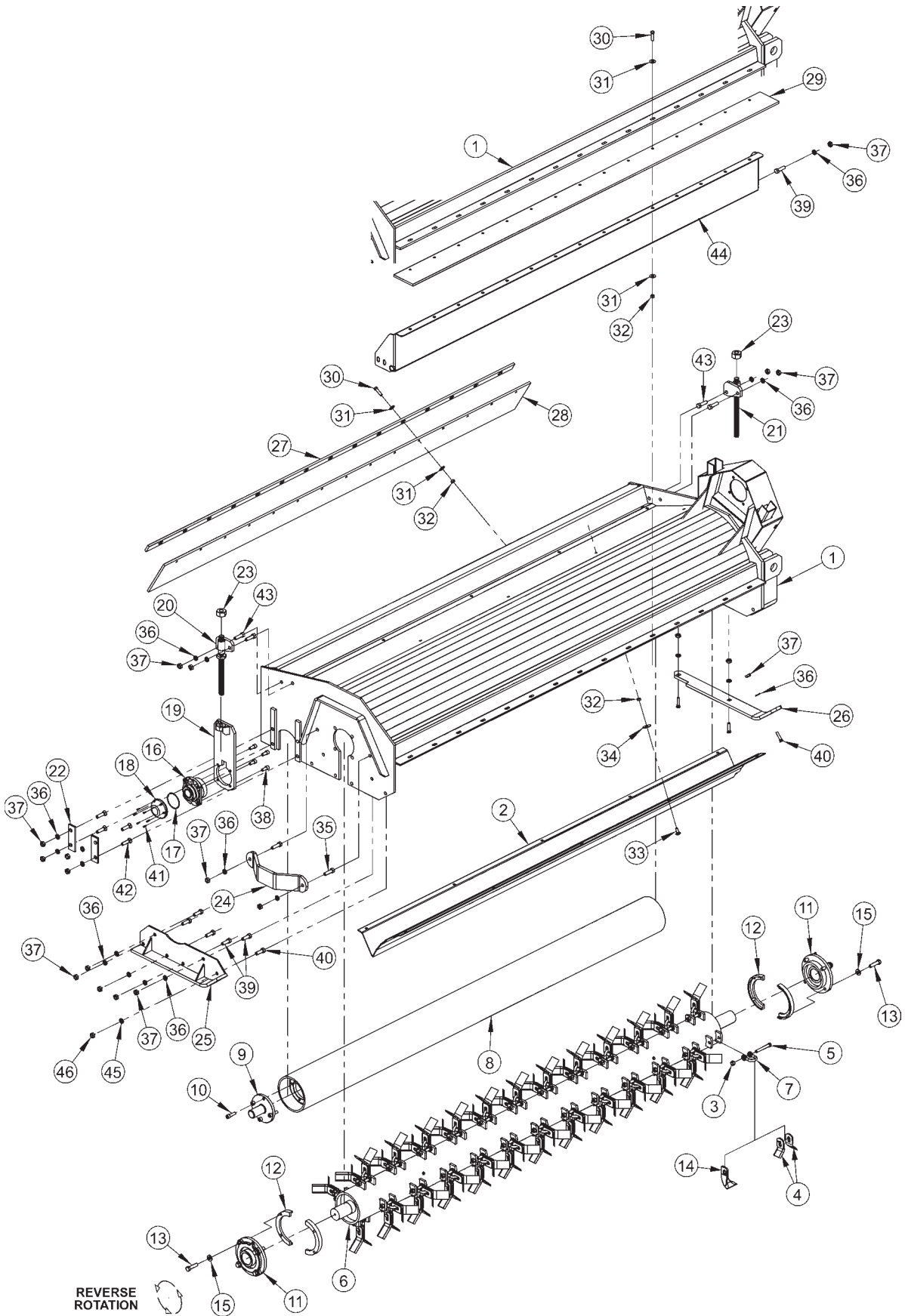

REVERSE ROTATION

Side Flail Heavy Duty Common Section 6-18

75" SIDE FLAIL REVESE ROTATION - COMBO

ITEM	P/N	QTY	DESCRIPTION
1	21499A	1	BONNET,75,HD,T3F,RT
2	TF1402A	1	BAFFLE,FLAIL,75HD (STANDARD ROTATION ONLY)
	TF1002A	1	CUTSHFT ASSY,75HD,STD KNIFE
3	21677	40	NYLOCK NUT,7/16 NC
4	33714	80	KNIFE,FLAIL,STANDARD
5	34011	40	CAPSCREW,7/16x3 7/16,NC GR8
6	TF1002	1	CUTTERSHAFT,75,HD
7	TF1020	40	KNIFE MTG CLEVIS,FLAIL
8	28738	1	GROUND ROLLER,75
9	TF1045B	2	STUB SHAFT,GROUND ROLLER
10	6T2330	8	CAPSCREW,SKT HD,7/16X1-1/2NC
11	TF1018	2	BEARING,FLANGE,2-3/16
	06200347	*	STRING GUARD,KIT,HD(ITEMS 12,13,15)
12	31204	2	STRING GUARD, HD
14	TF1019F	40	KNIFE,FLAIL (SMOOTH CUT)
13	06530217	8	CAPSCREW,1/2 X 2,NC,L9
15	06533006	12	FLATWASHER,1/2,SAE,L9
16	06520028	2	BEARING,FLANGE,1 3/8,GRNDRLR
17	06520029	2	O-RING,2 3/4x3/32,AS568A-148
18	06520027	2	CAP,BEARING,GRNDRLR
19	TF4333A	2	GROUND ROLLER ADJ,BRKT
20	TF4334	1	ROD,GROUND ROLLER ADJ,RT
21	TF4335	1	ROD,GROUND ROLLER ADJ,LF
22	TF4336	4	PLATE,GROUND ROLLER LOCK
23	21399	2	HEX NUT,3/4 (ACME) BULK
24	TF1040	1	GUARD,CUTTER SHAFT
25	TF4371	1	SKID SHOE,L/PROFILE-OUTER
26	23272A	1	SKID SHOE,T3F,INNER
27	TF1029	1	BAR,FLAP,TSF/TRF 75
28	TF1016	1	FLAP,DEFLECTOR,TSF/TRF 75
29	06520242	1	FLAP,75",FRONT
30	21632	30	CAPSCREW,3/8 X 1-1/2 NC
31	22016	60	FLATWASHER,3/8
32	21625	40	HEX NUT,3/8 NC
33	6T2283	10	CARRIAGE BOLT,3/8 X 1 NC
34	6T2615	10	WASHER,FENDER 3/8
35	21732	2	CAPSCREW,1/2 X 1-3/4 NC
36	21990	23	LOCKWASHER,1/2
37	21725	23	HEX NUT,1/2 NC
38	6T2331	8	CAPSCREW,SKT HD,7/16 X 1 NC
39	21730	6	CAPSCREW,1/2 X 1-1/4 NC
40	23293	3	PLOW,BOLT,1/2 X 1-3/4 NC
41	06530001	12	CAPSCREW,SKT HD,8-32x1/2,SS
42	6T2291	8	PLOW BOLT,1/2 X 2 NC GR5
43	21731	4	CAPSCREW,1/2 X 1-1/2 NC
44	TF1403	1	TRASH GUARD,75REV ROT-HD
45	22018	1	FLATWASHER,1/2,WIDE
46	21727	1	NYLOCK NUT,1/2 NC

90" SIDE FLAIL, STANDARD ROTATION - CABLE

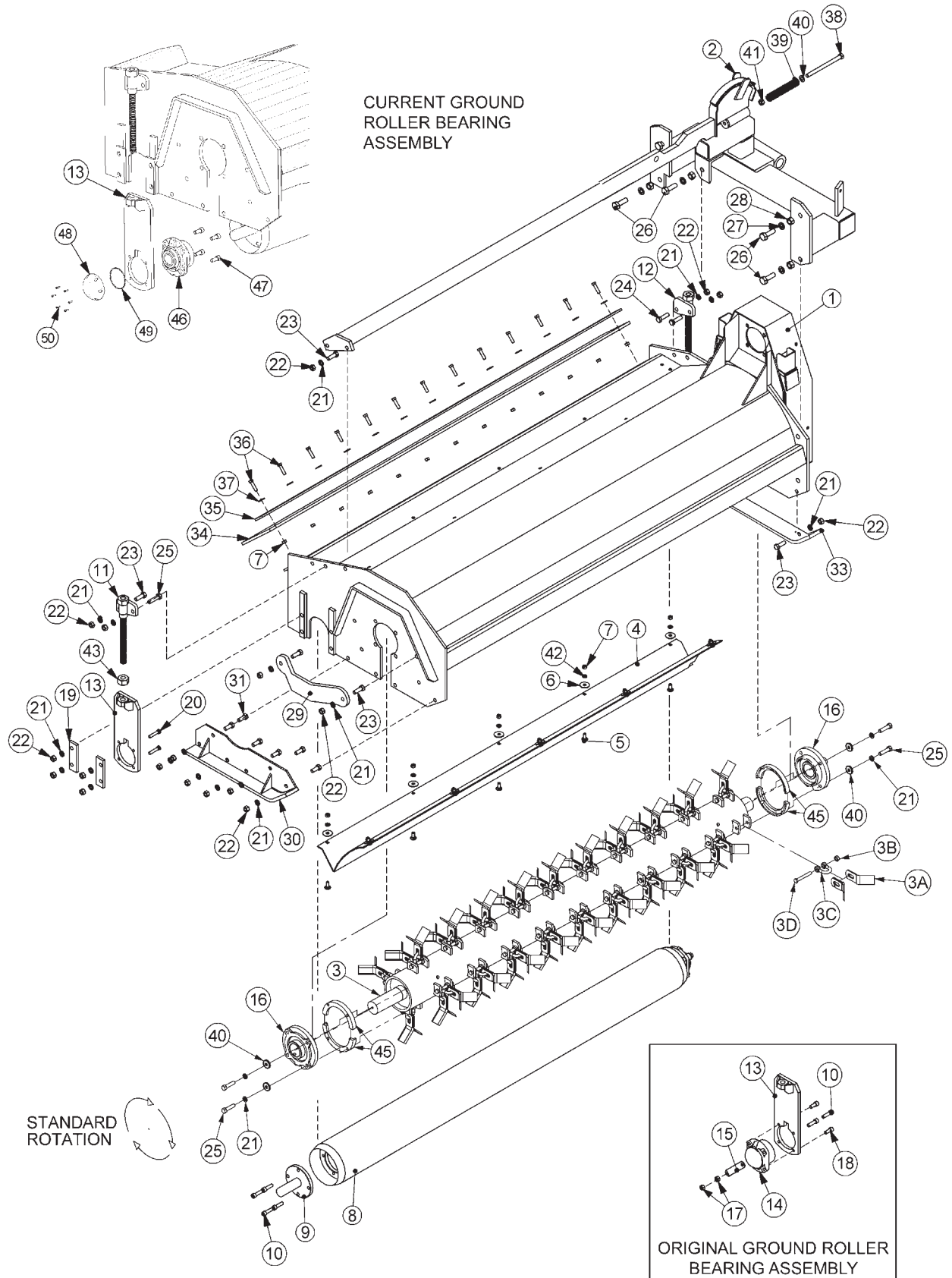

33076

Side Flail Heavy Duty Common Section 6-20

90" SIDE FLAIL, STANDARD ROTATION - CABLE

ITEM	P/N	QTY	DESCRIPTION
1	27047	1	BONNET,90,HD,TSF
2	27048A	1	MOUNTING FRAME
3	TF1102A	1	CUTTERSHAFT,ASSY,90" HD,STC
3A	33714	96	KNIFE,FLAIL,STANDARD
3B	21677	48	NYLOCK NUT,7/16" NC
3C	TF1020	48	KNIFE MTG CLEVIS,FLAIL
3D	34011	48	KNIFE MTG BOLT,FLAIL
4	TF1502A	1	BAFFLE,FLAIL,90" HD,STC
5	6T2283	10	CARRIAGE BOLT,3/8" X 1"NC
6	6T2615	10	WASHER,FENDER 3/8"
7	21625	23	HEX NUT,3/8",NC
8	27972A	1	GROUND ROLLER
9	TF1045B	2	GRND ROLLER STUB SHAFT
10	6T2330	12	CAPSCREW, 7/16 x 1 1/2, SOCKET HEAD
11	TF4334	1	ROD,GROUND ROLLER ADJ,RT
12	TF4335	1	ROD,GROUND ROLLER ADJ,LF
13	TF4333A	2	GROUND ROLLER ADJ BRK
14	TF1022S	2	BEARING,FLANGE,1-3/8"
15	30565	2	BEARING CAP KEEPER
16	TF1018	2	BEARING,FLANGE,2-3/16"
17	24701	4	HEX NUT, 7/16" NC (STOVER NUT)
18	6T2331	4	CAPSCREW, 7/16 x 1, SOCKET HEAD
19	TF4336	4	CLAMPING BLOCK, LH
20	6T2291	8	PLOW BOLT,1/2" X 2" NC
21	21990	31	LOCKWASHER, 1/2"
22	21725	23	HEX NUT, 1/2" NC
23	21731	6	CAPSCREW, 1/2 X 1 1/2,NC
24	21732	2	CAPSCREW, 1/2 x 1 3/4,NC
25	21733	9	CAPSCREW, 1/2 x 2,NC
26	21783	5	CAPSCREW, 5/8 x 2,NC
27	21992	5	LOCKWASHER, 5/8
28	21775	5	HEX NUT, 5/8
29	TF1040	1	GUARD, CUTTER SHAFT
30	TF4371	1	SKID SHOE,L/PROFILE - OUTER
31	21730	6	CAPSCREW, 1/2 X 1 1/4,NC
33	TF4365	1	SKID SHOE,L/PROFILE - INNER
34	TF1116	1	FLAP,DEFLECTOR,TSF/TRF 90
35	TF1135	1	FLAP RETAINING BAR
36	21632	13	CAPSCREW,3/8" X 1-1/2" NC
37	22016	13	FLATWASHER,3/8"
38	21745	1	CAPSCREW, 1/2 x 7,NC
39	27005	1	SPRING, PUSHOFF, SIDE RTRY
40	27938	9	BUSHING,MACH,1ODx1/2IDx14GA.
41	21727	1	NYLOCK NUT, 1/2
42	21988	10	LOCKWASHER, 3/8"
43	21399	2	HEX NUT, 3/4" (ACME THRD)
45	31204	2	STRING GUARD, HD
46	06520028	2	BEARING,FLANGE, 1 3/8"
47	6T2331	8	CAPSCREW, 7/16" X 1", SOCKET HEAD
48	06520027	2	CAP,BEARING, GRND ROLLER
49	06520029	2	O-RING,2 3/4" X 3/32"
50	06530001	12	CAPSCREW, SKT HD

90" SIDE FLAIL, REVERSE ROTATION - CABLE

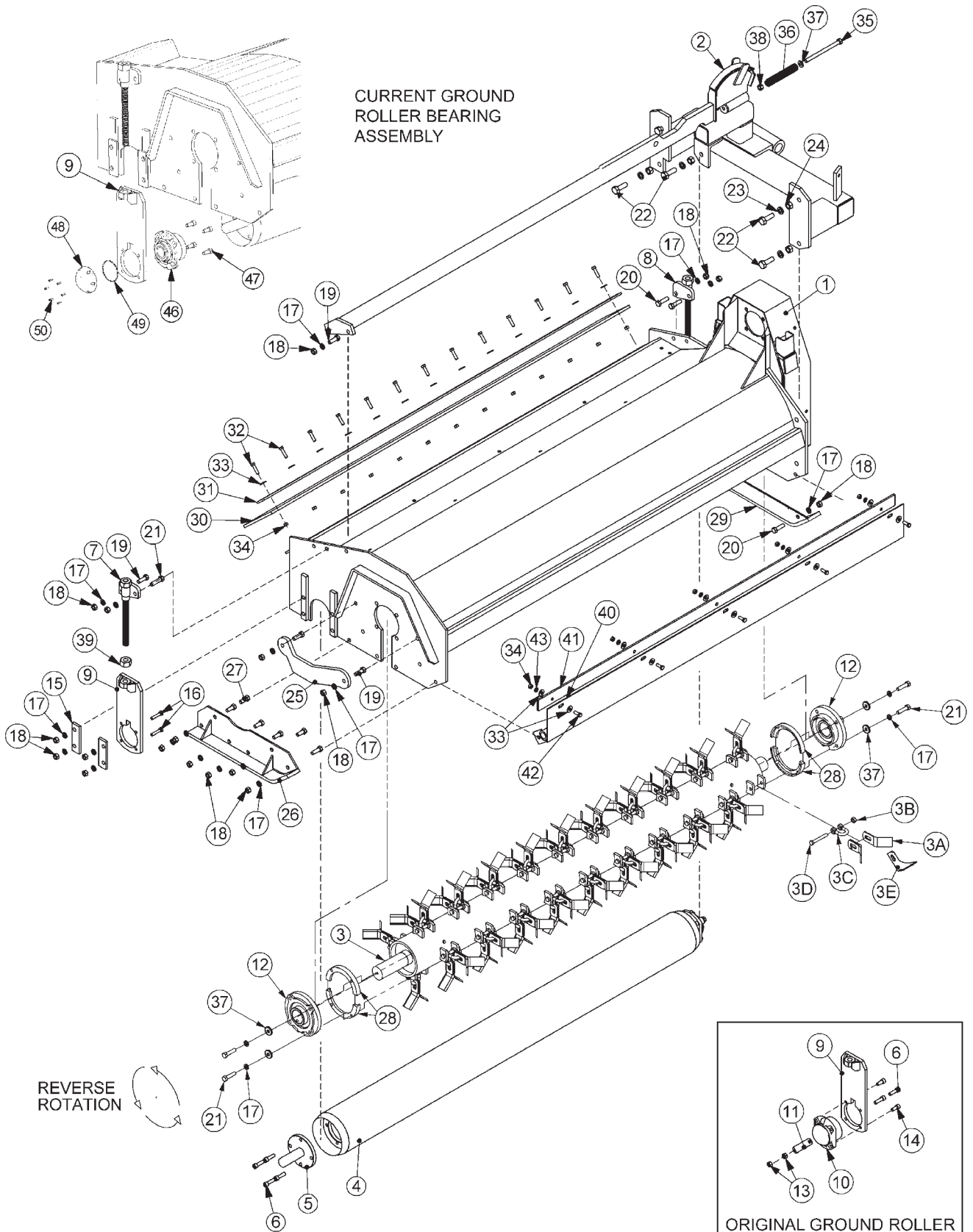

33077

Side Flail Heavy Duty Common Section 6-22

90" SIDE FLAIL, REVERSE ROTATION - CABLE

ITEM	P/N	QTY	DESCRIPTION
1	27047	1	BONNET,90,HD,TSF
2	27048A	1	MOUNTING FRAME
3	TF1102A	1	CUTTERSHAFT,ASSY,90" HD,STC
3A	33714	96	KNIFE,FLAIL,STANDARD
3B	21677	48	NYLOCK NUT,7/16" NC
3C	TF1020	48	KNIFE MTG CLEVIS,FLAIL
3D	34011	48	KNIFE MTG BOLT,FLAIL
3E	TF1019F	48	KNIFE,FLAIL (SMOOTH CUT)
4	27972A	1	GROUND ROLLER
5	TF1045B	2	GRND ROLLER STUB SHAFT
6	6T2330	12	CAPSCREW, 7/16 x 1 1/2, SOCKET HEAD
7	TF4334	1	ROD,GROUND ROLLER ADJ,RT
8	TF4335	1	ROD,GROUND ROLLER ADJ,LF
9	TF4333A	2	GROUND ROLLER ADJ BRK
10	TF1022S	2	BEARING,FLANGE,1-3/8"
11	30565	2	BEARING CAP KEEPER
12	TF1018	2	BEARING,FLANGE,2-3/16"
13	24701	4	HEX NUT, 7/16" NC (STOVER NUT)
14	6T2331	4	CAPSCREW, 7/16 x 1, SOCKET HEAD
15	TF4336	4	CLAMPING BLOCK, LH
16	6T2291	8	PLOW BOLT,1/2" X 2" NC
17	21990	31	LOCKWASHER, 1/2"
18	21725	23	HEX NUT, 1/2" NC
19	21731	6	CAPSCREW, 1/2 X 1 1/2,NC
20	21732	3	CAPSCREW, 1/2 x 1 3/4,NC
21	21733	9	CAPSCREW, 1/2 x 2,NC
22	21783	5	CAPSCREW, 5/8 x 2,NC
23	21992	5	LOCKWASHER, 5/8
24	21775	5	HEX NUT, 5/8
25	TF1040	1	GUARD, CUTTER SHAFT
26	TF4371	1	SKID SHOE,L/PROFILE - OUTER
27	21730	5	CAPSCREW, 1/2 X 1 1/4,NC
28	31204	2	STRING GUARD, HD
29	TF4365	1	SKID SHOE,L/PROFILE - INNER
30	TF1116	1	FLAP,DEFLECTOR,TSF/TRF 90
31	TF1135	1	FLAP RETAINING BAR
32	21632	13	CAPSCREW,3/8" X 1-1/2" NC
33	22016	23	FLATWASHER,3/8"
34	21625	18	HEX NUT,3/8",NC
35	21745	1	CAPSCREW, 1/2 x 7,NC
36	27005	1	SPRING, PUSHOFF, SIDE RTRY
37	27938	9	BUSHING,MACH,10Dx1/2IDx14GA.
38	21727	1	NYLOCK NUT, 1/2
39	21399	2	HEX NUT, 3/4" (ACME THRD)
40	TF1503	1	FRONT TRASH GUARD
41	21358	1	BAR, TRASH GUARD
42	21630	5	CAPSCREW, 3/8 x 1,NC
43	21988	5	LOCKWASHER, 3/8"
46	06520028	2	BEARING,FLANGE, 1 3/8"
47	6T2331	8	CAPSCREW, 7/16" X 1", SOCKET HEAD
48	06520027	2	CAP,BEARING, GRND ROLLER
49	06520029	2	O-RING,2 3/4" X 3/32"
50	06530001	12	CAPSCREW, SKT HD

90" SIDE FLAIL, STANDARD ROTATION - COMBO

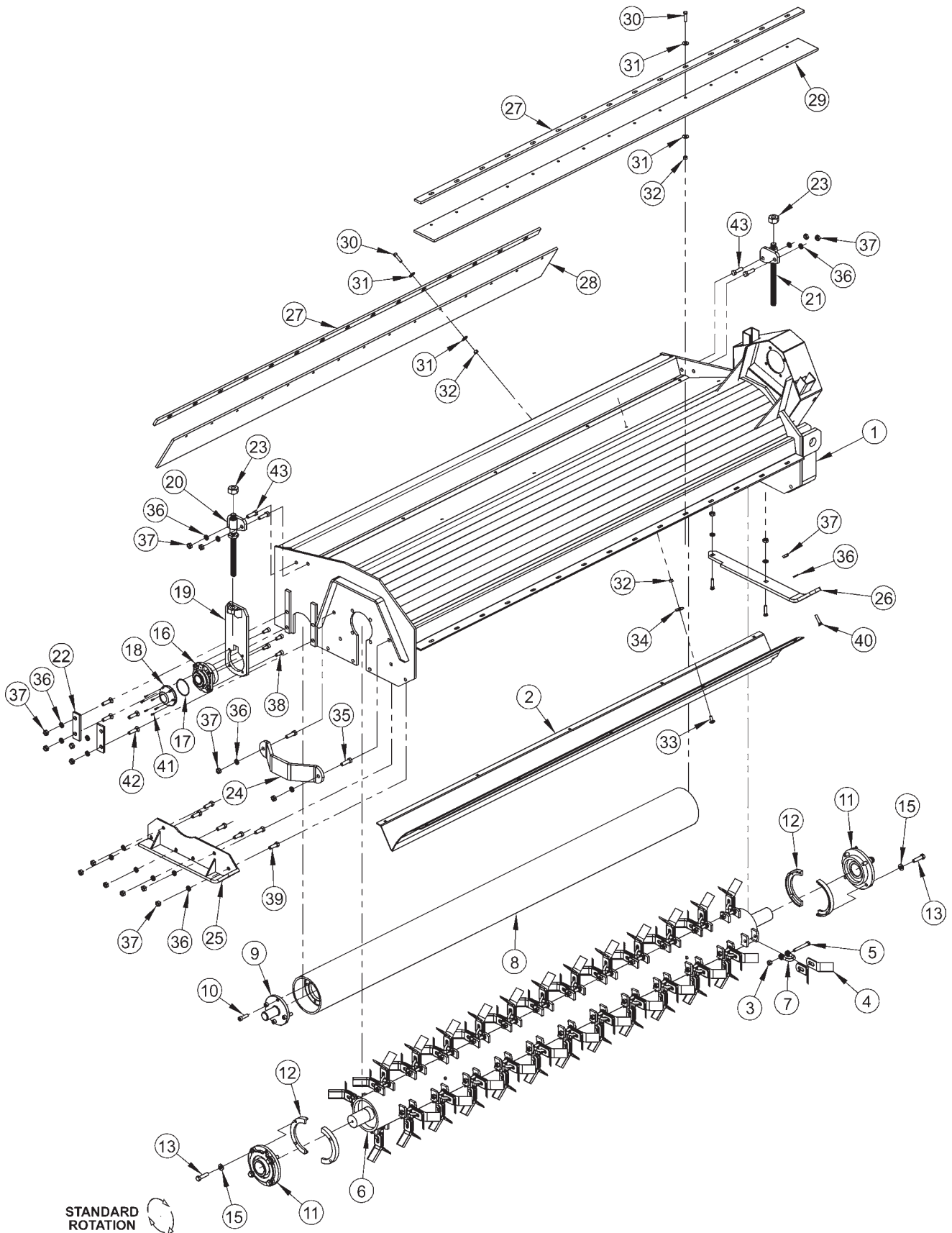

STANDARD
ROTATION

90" SIDE FLAIL, STANDARD ROTATION - COMBO

ITEM	P/N	QTY	DESCRIPTION
1	22083A	1	BONNET,90,HD,T3F,RT
2	TF1502A	1	BAFFLE,FLAIL,90HD,STD ROT
	TF1102A	1	CUTSHFT ASSY,90HD,STD KNIVES
3	21677	48	NYLOCK NUT,7/16 NC
4	33714	96	KNIFE,FLAIL,STANDARD
5	34011	48	CAPSCREW,7/16x3 7/16,NC GR8
6	TF1102	1	CUTTERSHAFT,90,HD
7	TF1020	48	KNIFE MTG CLEVIS,FLAIL
8	27972A	1	GROUND ROLLER,90
9	TF1045B	2	STUB SHAFT,GROUND ROLLER
10	6T2330	8	CAPSCREW,SKT HD,7/16X1-1/2NC
11	TF1018	2	BEARING,FLANGE,2-3/16
	06200347	*	STRING GUARD,KIT,HD(ITEMS 12,13,15)
12	31204	2	STRING GUARD, HD
13	06530217	8	CAPSCREW,1/2 X 2,NC,L9
15	06533006	12	FLATWASHER,1/2,SAE,L9
16	06520028	2	BEARING,FLANGE,1 3/8,GRNDRLR
17	06520029	2	O-RING,2 3/4x3/32,AS568A-148
18	06520027	2	CAP,BEARING,GRNDRLR
19	TF4333A	2	GROUND ROLLER ADJ,BRKT
20	TF4334	1	ROD,GROUND ROLLER ADJ,RT
21	TF4335	1	ROD,GROUND ROLLER ADJ,LF
22	TF4336	4	PLATE,GROUND ROLLER LOCK
23	21399	2	HEX NUT,3/4 (ACME) BULK
24	TF1040	1	GUARD,CUTTER SHAFT
25	TF4371	1	SKID SHOE,L/PROFILE-OUTER
26	23272A	1	SKID SHOE,T3F,INNER
27	TF1135	2	BAR,FLAP,TSF/TRF 90
28	TF1116	1	FLAP,DEFLECTOR,TSF/TRF 90
29	06520243	1	FLAP,90",FRONT
30	21632	30	CAPSCREW,3/8 X 1-1/2 NC
31	22016	60	FLATWASHER,3/8
32	21625	40	HEX NUT,3/8 NC
33	6T2283	10	CARRIAGE BOLT,3/8 X 1 NC
34	6T2615	10	WASHER,FENDER 3/8
35	21732	2	CAPSCREW,1/2 X 1-3/4 NC
36	21990	23	LOCKWASHER,1/2
37	21725	23	HEX NUT,1/2 NC
38	6T2331	8	CAPSCREW,SKT HD,7/16 X 1 NC
39	21730	6	CAPSCREW,1/2 X 1-1/4 NC
40	23293	3	PLOW,BOLT,1/2 X 1-3/4 NC
41	06530001	12	CAPSCREW,SKT HD,8-32x1/2,SS
42	6T2291	8	PLOW BOLT,1/2 X 2 NC GR5
43	21731	4	CAPSCREW,1/2 X 1-1/2 NC

90" SIDE FLAIL, REVERSE ROTATION - COMBO

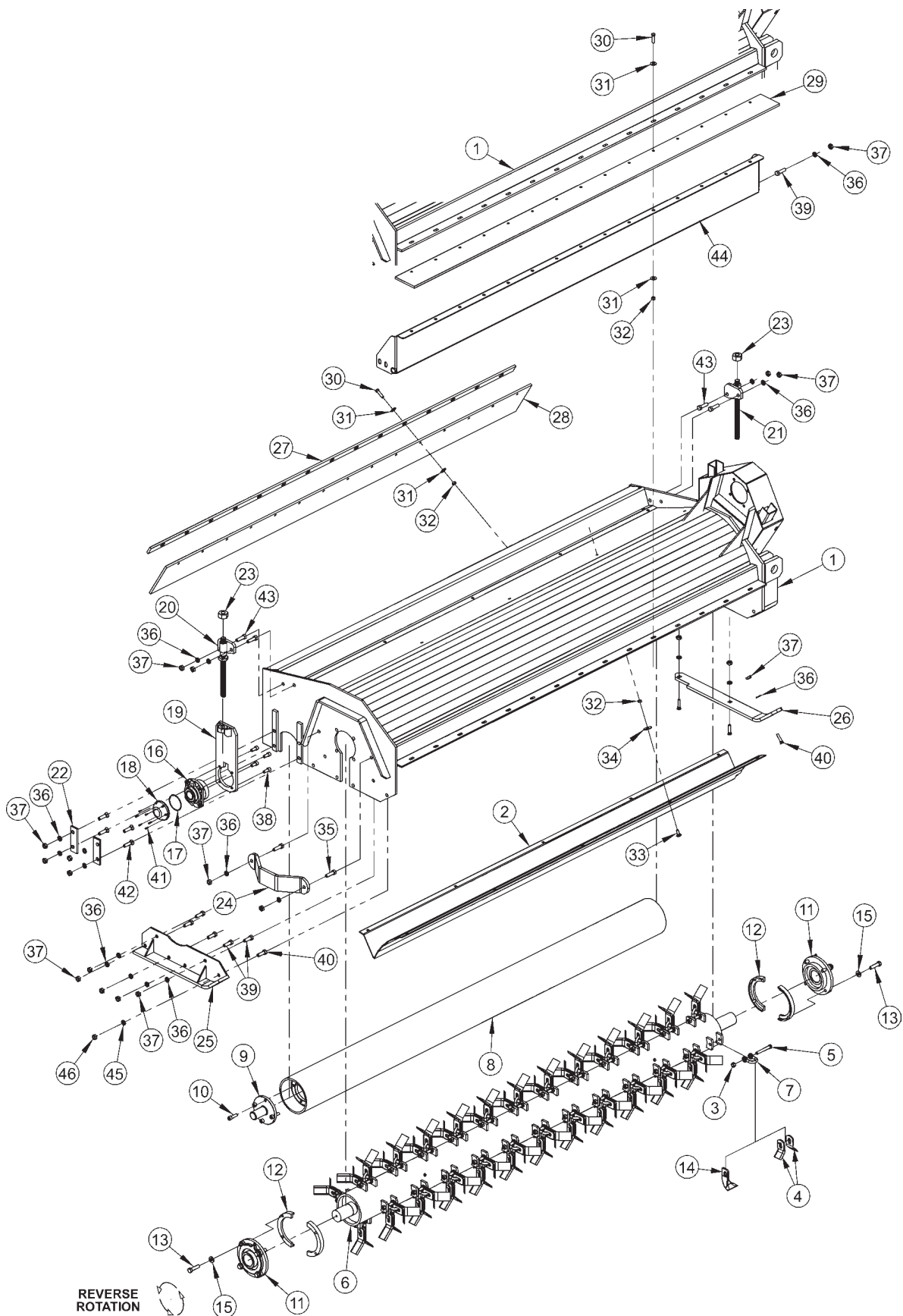

Side Flail Heavy Duty Common Section 6-26

90" SIDE FLAIL, REVERSE ROTATION - COMBO

ITEM	P/N	QTY	DESCRIPTION
1	22083A	1	BONNET,90,HD,T3F,RT
1	22084A	1	BONNET 90" T3F
2	TF1502A	1	BAFFLE,FLAIL,90HD (STANDARD ROTATION ONLY)
	TF1102A	1	CUTSHFT ASSY,90HD,STD KNIVES
3	21677	48	NYLOCK NUT,7/16 NC
4	33714	96	KNIFE,FLAIL,STANDARD
5	34011	48	CAPSCREW,7/16x3 7/16,NC GR8
6	TF1102	1	CUTTERSHAFT,90,HD
7	TF1020	48	KNIFE MTG CLEVIS,FLAIL
8	27972A	1	GROUND ROLLER,90
9	TF1045B	2	STUB SHAFT,GROUND ROLLER
10	6T2330	8	CAPSCREW,SKT HD,7/16X1-1/2NC
11	TF1018	2	BEARING,FLANGE,2-3/16
	06200347	*	STRING GUARD,KIT,HD(ITEMS 12,13,15)
12	31204	2	STRING GUARD, HD
13	06530217	8	CAPSCREW,1/2 X 2,NC,L9
14	TF1019F	48	KNIFE,FLAIL (SMOOTH CUT)
15	06533006	12	FLATWASHER,1/2,SAE,L9
16	06520028	2	BEARING,FLANGE,1 3/8,GRNDRLR
17	06520029	2	O-RING,2 3/4x3/32,AS568A-148
18	06520027	2	CAP,BEARING,GRNDRLR
19	TF4333A	2	GROUND ROLLER ADJ,BRKT
20	TF4334	1	ROD,GROUND ROLLER ADJ,RT
21	TF4335	1	ROD,GROUND ROLLER ADJ,LF
22	TF4336	4	PLATE,GROUND ROLLER LOCK
23	21399	2	HEX NUT,3/4 (ACME) BULK
24	TF1040	1	GUARD,CUTTER SHAFT
25	TF4371	1	SKID SHOE,L/PROFILE-OUTER
26	23272A	1	SKID SHOE,T3F,INNER
27	TF1135	1	BAR,FLAP,TSF/TRF 90
28	TF1116	1	FLAP,DEFLECTOR,TSF/TRF 90
29	06520243	1	FLAP,90",FRONT
30	21632	30	CAPSCREW,3/8 X 1-1/2 NC
31	22016	60	FLATWASHER,3/8
32	21625	40	HEX NUT,3/8 NC
33	6T2283	10	CARRIAGE BOLT,3/8 X 1 NC
34	6T2615	10	WASHER,FENDER 3/8
35	21732	2	CAPSCREW,1/2 X 1-3/4 NC
36	21990	23	LOCKWASHER,1/2
37	21725	23	HEX NUT,1/2 NC
38	6T2331	8	CAPSCREW,SKT HD,7/16 X 1 NC
39	21730	6	CAPSCREW,1/2 X 1-1/4 NC
40	23293	3	PLOW,BOLT,1/2 X 1-3/4 NC
41	06530001	12	CAPSCREW,SKT HD,8-32x1/2,SS
42	6T2291	8	PLOW BOLT,1/2 X 2 NC GR5
43	21731	4	CAPSCREW,1/2 X 1-1/2 NC
44	TF1503	1	TRASH GUARD,90REV ROT-HD
45	22018	1	FLATWASHER,1/2,WIDE
46	21727	1	NYLOCK NUT,1/2 NC

SIDE FLAIL DRIVE ASSY - COMBO

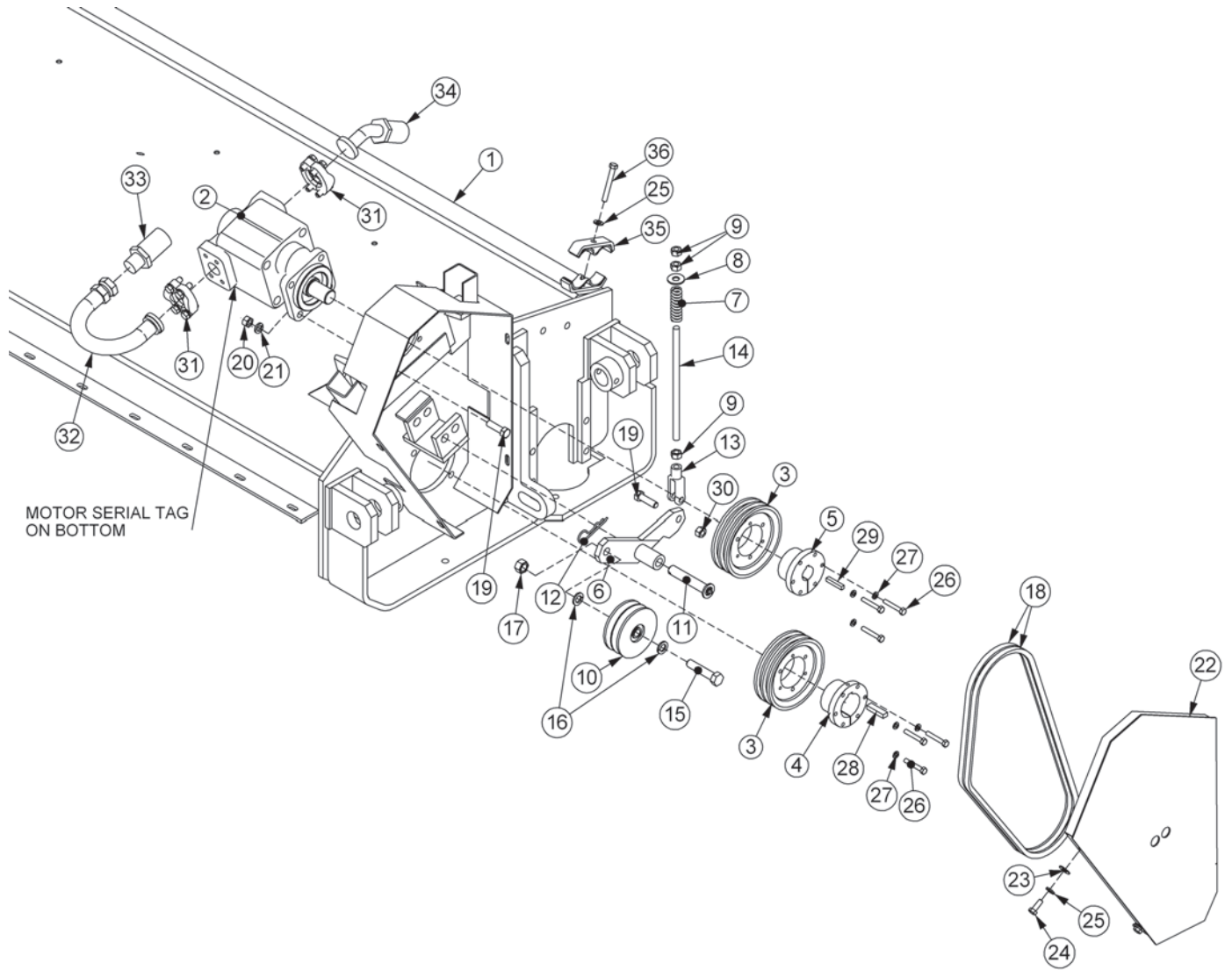

SIDE FLAIL DRIVE ASSY - COMBO

ITEM	P/N	QTY	DESCRIPTION
1	*	REF	BONNET - REFER TO FLAIL PARTS
2	06504013	1	MOTOR,TSF
3	TF3040	2	SHEAVE,6.3
4	TF3011	1	BUSHING,QD,SK,2-3/16"
5	TF3013	1	BUSHING,QD,SK 1-1/4"
6	TF4345	OPT.	IDLER ARM (REVERSE ROTATION - NOT SHOWN)
6	TF4346	1	IDLER ARM (STANDARD ROTATION)
7	TF3620A	1	SPRING,TENSIONER
8	22018	1	FLATWASHER,1/2",WIDE
9	21700	3	HEX NUT, 1/2", NF
10	31293	1	SHEAVE,IDLER ASSY, 4.4 O.D.
11	TF3605	1	PIN,IDLER ARM 3/4"X4-1/4"
12	6T3004	1	R-CLIP (HAIRPIN COTTER, 3/16")
13	PT3611A	1	CLEVIS,6"
14	32494	1	ROD, THREADED, 1/2-20NF
15	21787	1	CAPSCREW,5/8" x 3", NC
16	21992	2	LOCKWASHER, 5/8
17	21775	1	HEX NUT, 5/8
18	TF3020	2	V-BELT, (530)
19	21732	5	CAPSCREW, 1/2 x 1 3/4,NC
20	21725	4	HEX NUT, 1/2" NC
21	21990	4	LOCKWASHER, 1/2"
22	TF4564	1	BELT SHEILD (RIGHT)
23	22016	4	FLATWASHER,3/8"
24	21630	4	CAPSCREW, 3/8 x 1,NC
25	21988	5	LOCKWASHER, 3/8"
26	21584	6	CAPSCREW, 5/16 x 2,NC
27	21987	6	LOCKWASHER, 5/16"
28	TF1025	1	KEY,1/4" X 1/2" X 1-7/8" SQ
29	TF1125	1	KEY,3/8" X 1/2" X 1-7/8" SQ
30	21727	1	NYLOCK NUT, 1/2
31	TF4852	2	KIT,FLANGE,#20
32	34227	1	PREFORMED TUBE
33	*	REF	HOSE (RETURN FOR STANDARD ROTATION)
34	*	REF	HOSE (PRESSURE FOR STANDARD ROTATION)
35	TB3031	1	CLAMP,HOSE
36	21638	1	CAPSCREW,3/8 x 3,NC

SIDE FLAIL DRIVE ASSY - CABLE

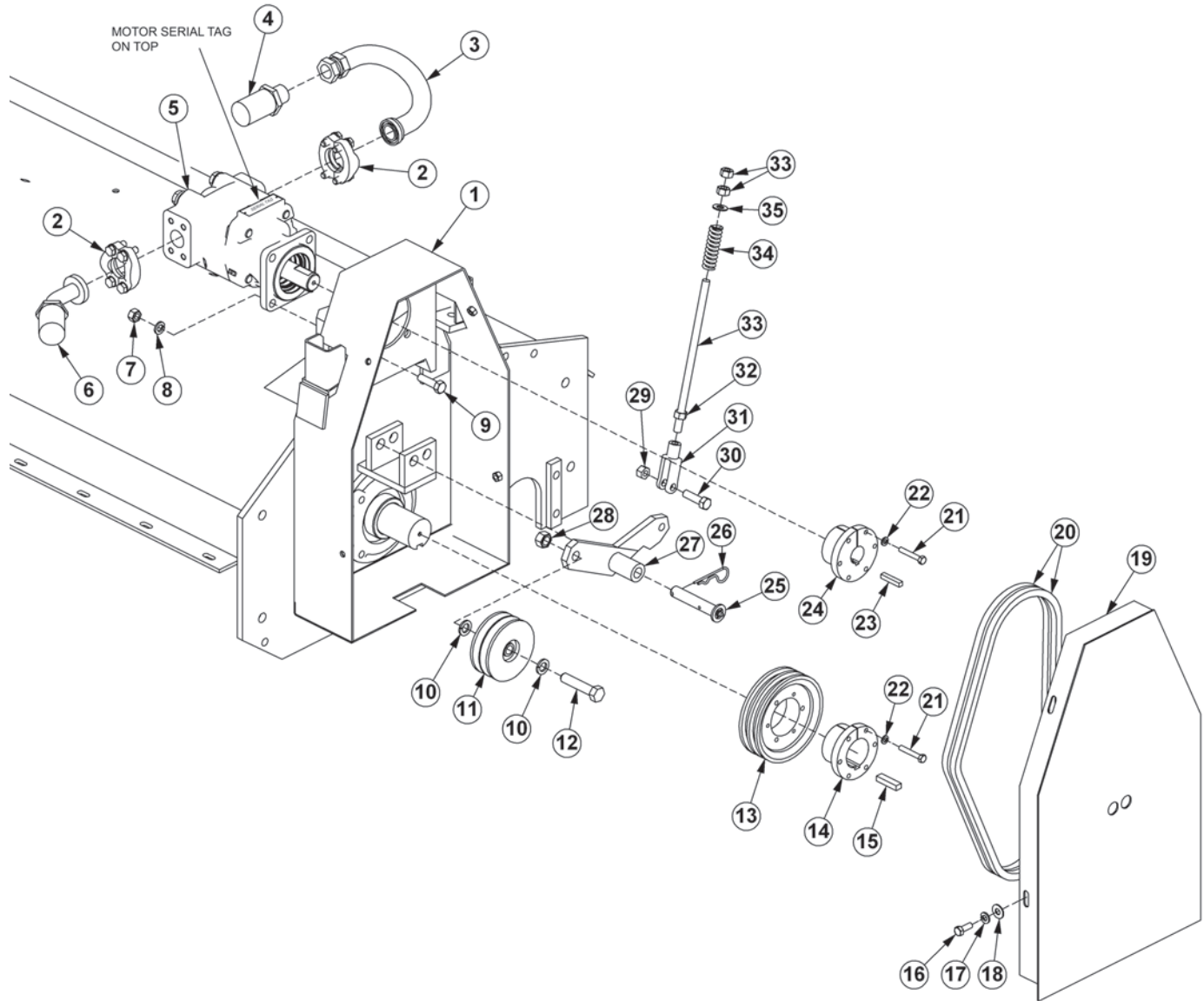

SIDE FLAIL DRIVE ASSY - CABLE

ITEM	P/N	QTY	DESCRIPTION
1	*	REF	BONNET - REFER TO FLAIL PARTS
2	TF4852	2	KIT,FLANGE,#20
3	34227	1	PREFORMED TUBE
4	*	REF	HOSE (RETURN FOR STANDARD ROTATION)
5	06504013	1	MOTOR
6	*	REF	HOSE (PRESSURE FOR STANDARD ROTATION)
7	21725	4	HEX NUT,1/2,NC
8	21990	4	LOCKWASHER,1/2
9	21732	4	CAPSCREW,1/2 x 1-3/4,NC
10	21992	2	LOCKWASHER,5/8
11	31293	1	SHEAVE,IDLER,ASSY,4.4 O.D.
12	21787	1	CAPSCREW,5/8 x 3,NC
13	TF3040	1	SHEAVE,6.3 O.D.
14	TF3011	1	BUSHING,2-3/16
15	TF1025	1	KEY,3/8 x 1/2
16	21630	4	CAPSCREW,3/8 x 1,NC
17	21988	4	LOCKWASHER,3/8
18	22016	4	FLATWASHER,3/8
19	TF1404	1	SHIELD
20	TF3020	2	V-BELT (530)
21	21584	6	CAPSCREW,5/16 x 2,NC
22	21987	6	LOCKWASHER,5/16
23	TF1125	1	KEY,5/16 SQUARE
24	TF3013	1	BUSHING,1-1/4
25	TF3605	1	IDLER ARM PIN
26	6T3004	1	R-CLIP
27	TF4346	1	IDLER ARM (STANDARD ROTATION)
27	TF4345	OPT.	IDLER ARM (REVERSE ROTATION - NOT SHOWN)
28	21775	1	HEX NUT,5/8,NC
29	6T2418	1	HEX NUT,1/2,NC,STOVER
30	21732	1	CAPSCREW,1/2 x 1-3/4,NC
31	PT3611A	1	CLEVIS
32	21700	3	HEX NUT,1/2,NF
33	32494	1	ROD,THREADED
34	TF3620A	1	TENSIONER SPRING
35	27938	1	MACHINED BUSHING

CABLE LIFT ARM ASSY

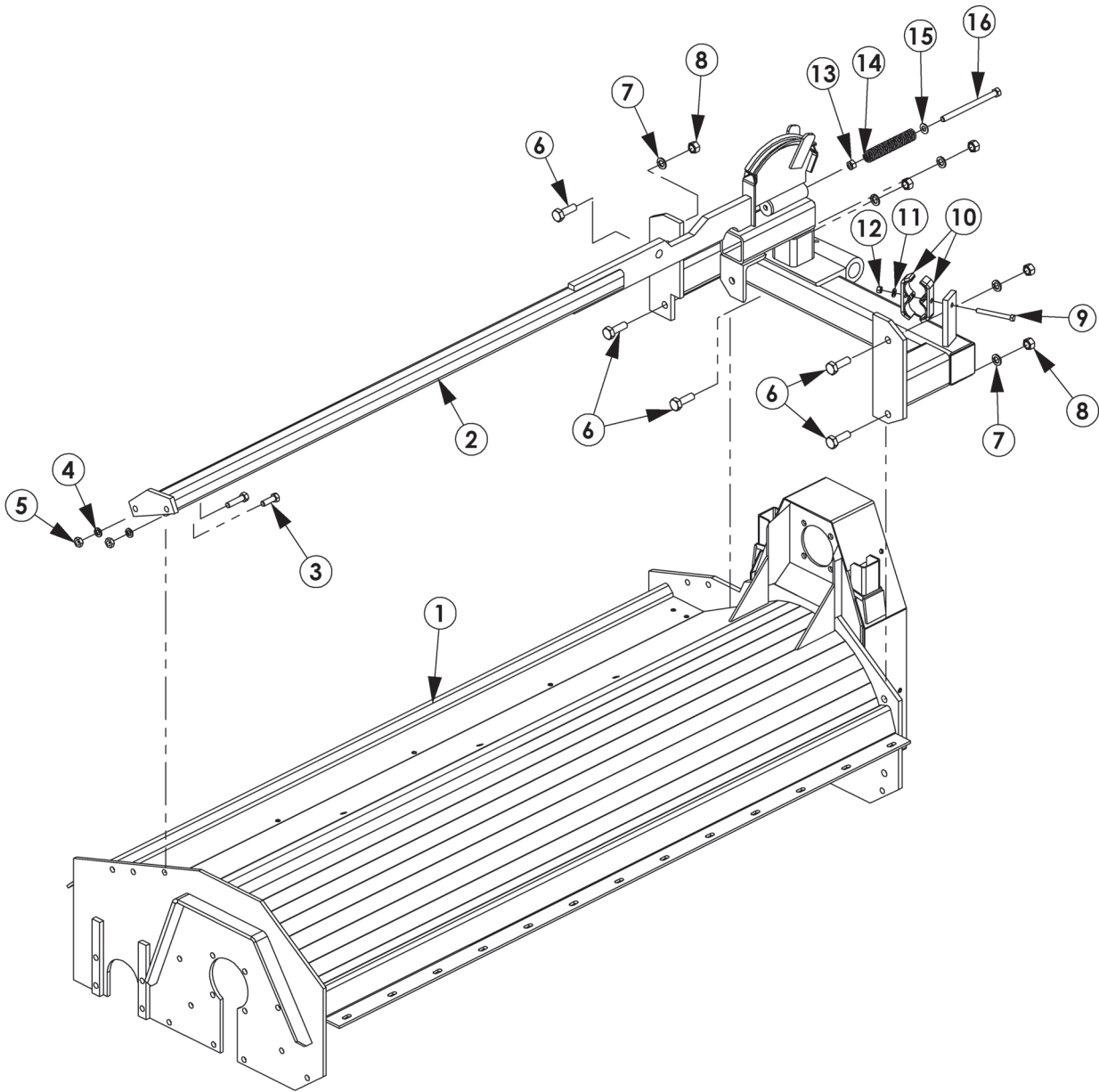

CABLE LIFT ARM ASSY

ITEM	P/N	QTY	DESCRIPTION
1	*	REF	BONNET - REFER TO FLAIL PARTS
2	21297C	1	LIFT ARM,TSF,60,CPLT
*	21298C	1	LIFT ARM,TSF,75,CPLT
*	27048A	1	LIFT ARM,TSF,90,CPLT
3	21733	2	CAPSCREW,1/2 x 2,NC
4	21990	2	LOCKWASHER,1/2
5	21725	2	HEX NUT,1/2,NC
6	21783	5	CAPSCREW,5/8 x 2,NC
7	21992	5	LOCKWASHER,5/8
8	21775	5	HEX NUT,5/8,NC
9	21640	1	CAPSCREW,3/8 x 3-1/2,NC
10	TB3031	2	CLAMP,HOSE
11	21988	1	LOCKWASHER,3/8
12	21625	1	HEX NUT,3/8,NC
13	21727	1	NYLOCK NUT,1/2,NC
14	27005	1	SPRING,PUSH-OFF
15	27938	1	MACHINED BUSHING
16	21745	1	CAPSCREW,1/2 x 7,NC

HYDRAULIC LIFT CYLINDER

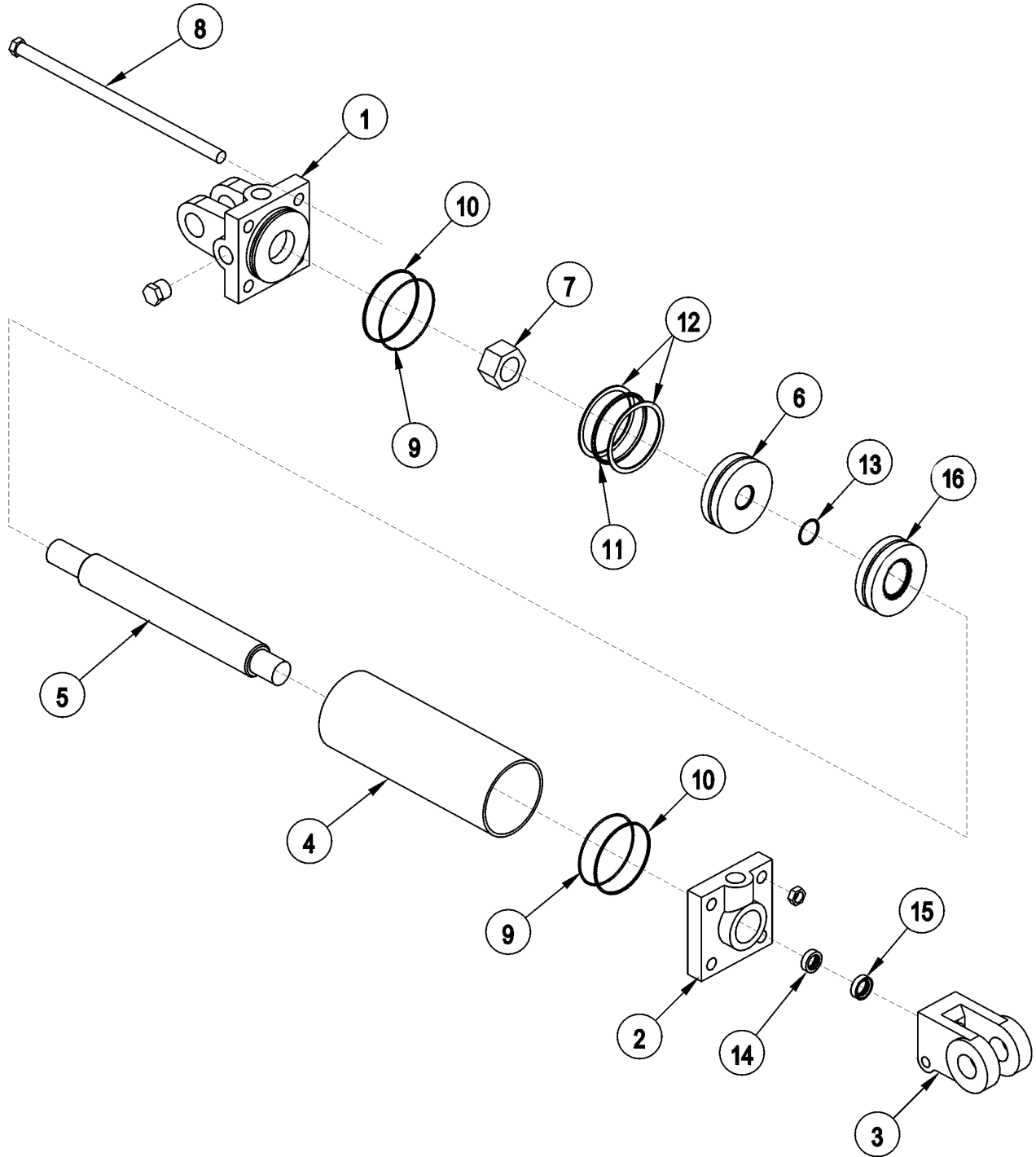

Tb1015

HYDRAULIC LIFT CYLINDER

3" X 10" CYLINDER #6T0151R

ITEM	PART NO.	QTY.	DESCRIPTION
1	6T0167	1	CYLINDER BUTT
2	6T0170	1	CYLINDER GLAND
3	6T0178	1	CLEVIS END
4	6T0164	1	CYLINDER TUBE
5	6T0161	1	PISTON ROD
6	6T0173	1	PISTON
7	6T0179	1	LOCKNUT
8	6T0176	4	TIE RODASY
	6T0187	AVAIL	SEAL KIT
9		2	O - RING
10		2	BACK - UP WASHER
11		1	O - RING
12		2	BACK - UP WASHER
13		1	O - RING
14		1	U - CUP
15		1	WIPER
16	NA		NA

3" X 11.5" CYLINDER #25343

ITEM	PART NO.	QTY.	DESCRIPTION
1	6T0167	1	CYLINDER BUTT
2	6T0170	1	CYLINDER GLAND
3	6T0178	1	CLEVIS END
4	6T0204	1	CYLINDER TUBE
5	6T0203	1	PISTON ROD
6	6T0173	1	PISTON
7	6T0179	1	LOCKNUT
8	6T0205	1	TIE RODASY
	6T0187	AVAIL	SEAL KIT
9		2	O - RING
10		2	BACK - UP WASHER
11		1	O - RING
12		2	BACK - UP WASHER
13		1	O - RING
14		1	U - CUP
15		1	WIPER
16	6T0206	1	SPACER

HYDRAULIC LIFT CYLINDER

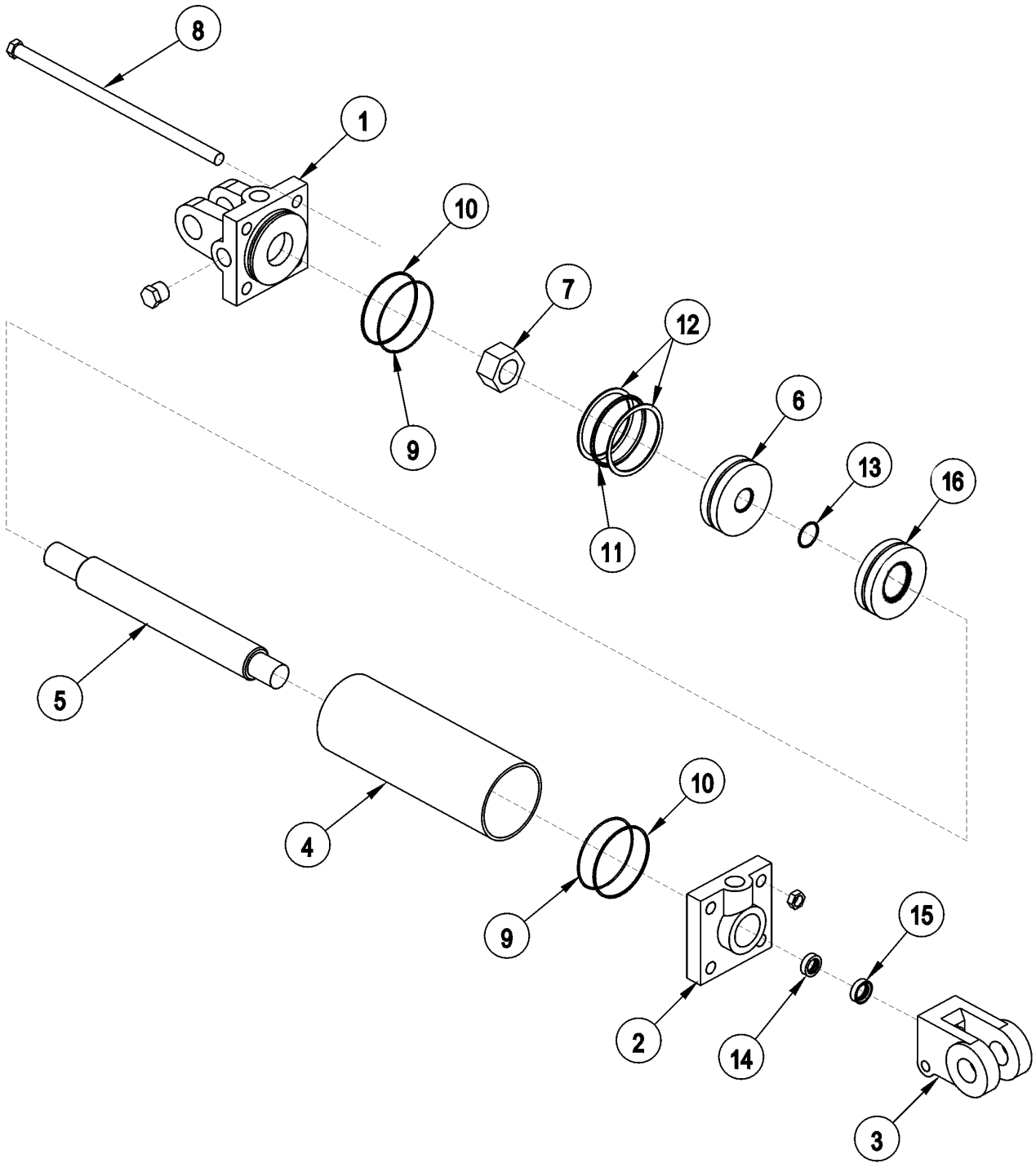

Tb1015

HYDRAULIC LIFT CYLINDER

3" X 12" CYLINDER # 32215

ITEM	PART NO.	QTY.	DESCRIPTION
1	6T0167	1	CYLINDER BUTT
2	6T0170	1	CYLINDER GLAND
3	6T0178	1	CLEVIS END
4	6T0204	1	CYLINDER TUBE
5	6T0203	1	PISTON ROD
6	6T0173	1	PISTON
7	6T0179	1	LOCKNUT
8	6T0205	1	TIE ROD ASY
	6T0187	AVAIL	SEAL KIT
9		2	O - RING
10		2	BACK - UP WASHER
11		1	O - RING
12		2	BACK - UP WASHER
13		1	O - RING
14		1	U - CUP
15		1	WIPER

RESERVOIR TANK FILTER ASSEMBLY

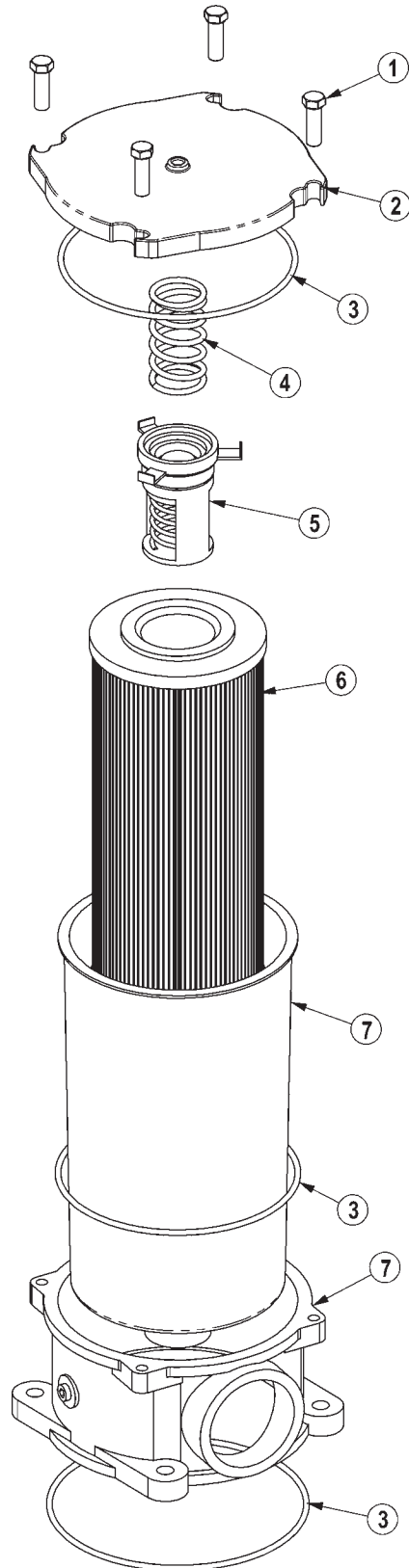

RESERVOIR TANK FILTER ASSEMBLY

ITEM	PART NO.	QTY.	DESCRIPTION
	06505044	AVAIL	FILTER ASSY SAE 10 MICRON
1	28583	4	CAPSCREW,8MMX25MM(1.25 PITCH)
2	06505045	1	COVER
3	06505046	1	SEAL KIT
4	06505047	1	SPRING
5	06505048	1	BYPASS
6	35259	1	FILTER,10 MIC,RETURN LINE
7	06505049	1	CAN/BODY

2SP HUSCO - LOAD SENSE (06502040)

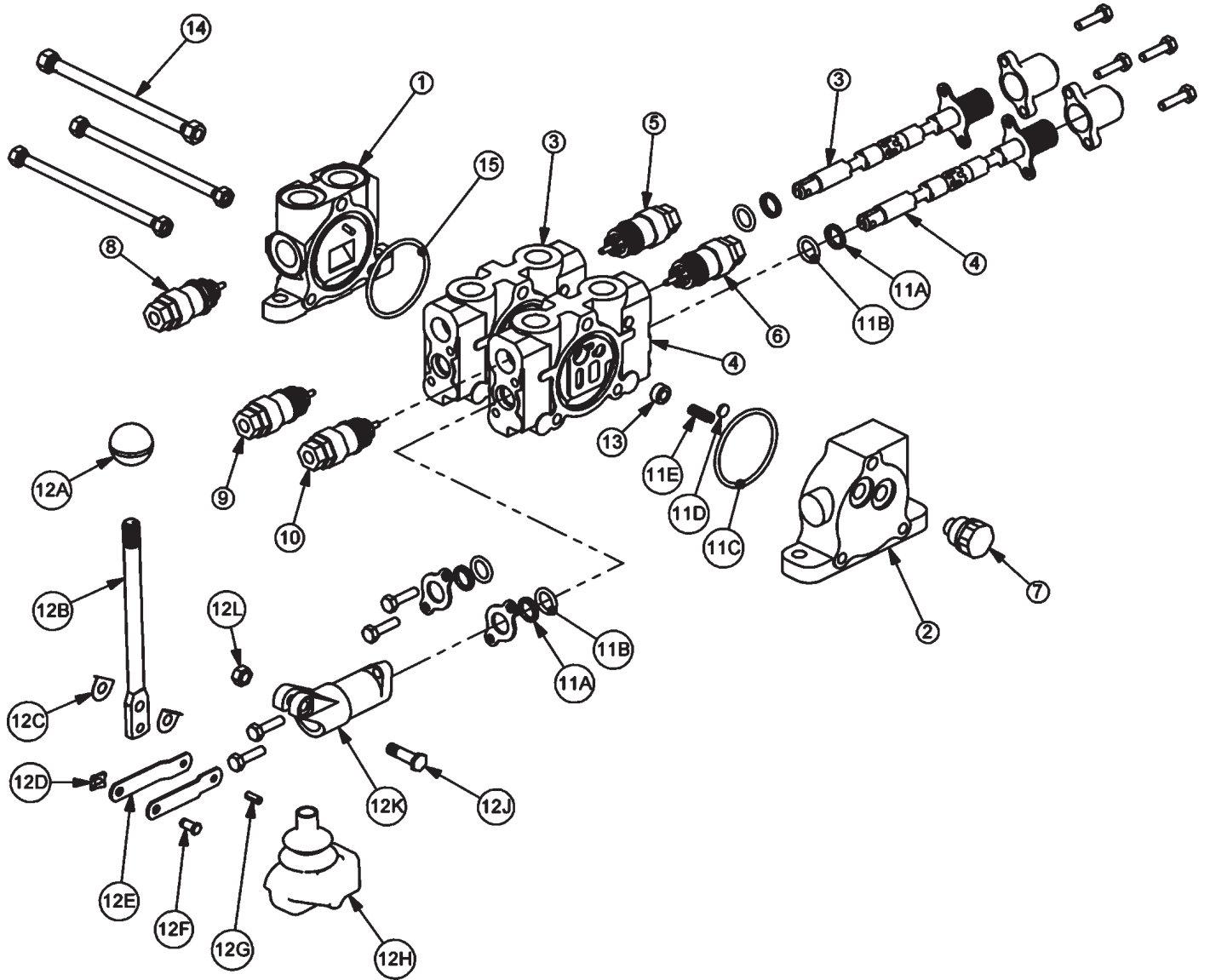

2SP HUSCO - LOAD SENSE (06502040)

ITEM	PART NO.	QTY	DESCRIPTION
1	31595	1	INLET END COVER
2	31594	1	END COVER, LOAD SENSE
3	31597	1	VALVE SECTION (DOUBLE ACTING, CENTER SPRING)
4	31597	1	VALVE SECTION (DOUBLE ACTING, CENTER SPRING) (REMOVE SHUTTLE DISC)
5	06503067	1	RELIEF PLUG
6	06503067	1	RELIEF PLUG
7	06503068	1	RELIEF PLUG
8	N/A	-	N/A
9	31862	1	RELIEF VALVE, 2175 PSI
10	31862	1	RELIEF VALVE, 2175 PSI
11	31593	2	VALVE SEAL KIT (FOR ONE SECTION)
11A		2	WIPER
11B		2	O-RING SMALL
11C		1	O-RING LARGE
11D		1	SHUTTLE DISC
11E		1	SPRING
12	TB1017L	2	LEVER KIT (FOR ONE SECTION)
12A		1	LEVER KNOB
12B		1	LEVER
12C		2	LEVER WASHER
12D		1	LEVER CLIP
12E		2	LINKAGE
12F		1	LEVER PIN
12G		1	ROLL PIN
12H		1	LEVER BOOT
12J		1	LEVER BOLT
12K		1	LEVER DUST COVER
12L		1	LEVER NUT
13	31603	2	COMPENSATOR
14	TB1017X	1	TIE ROD KIT
15	24214	1	O-RING, LARGE

2SP HUSCO - LOAD SENSE (06502042)

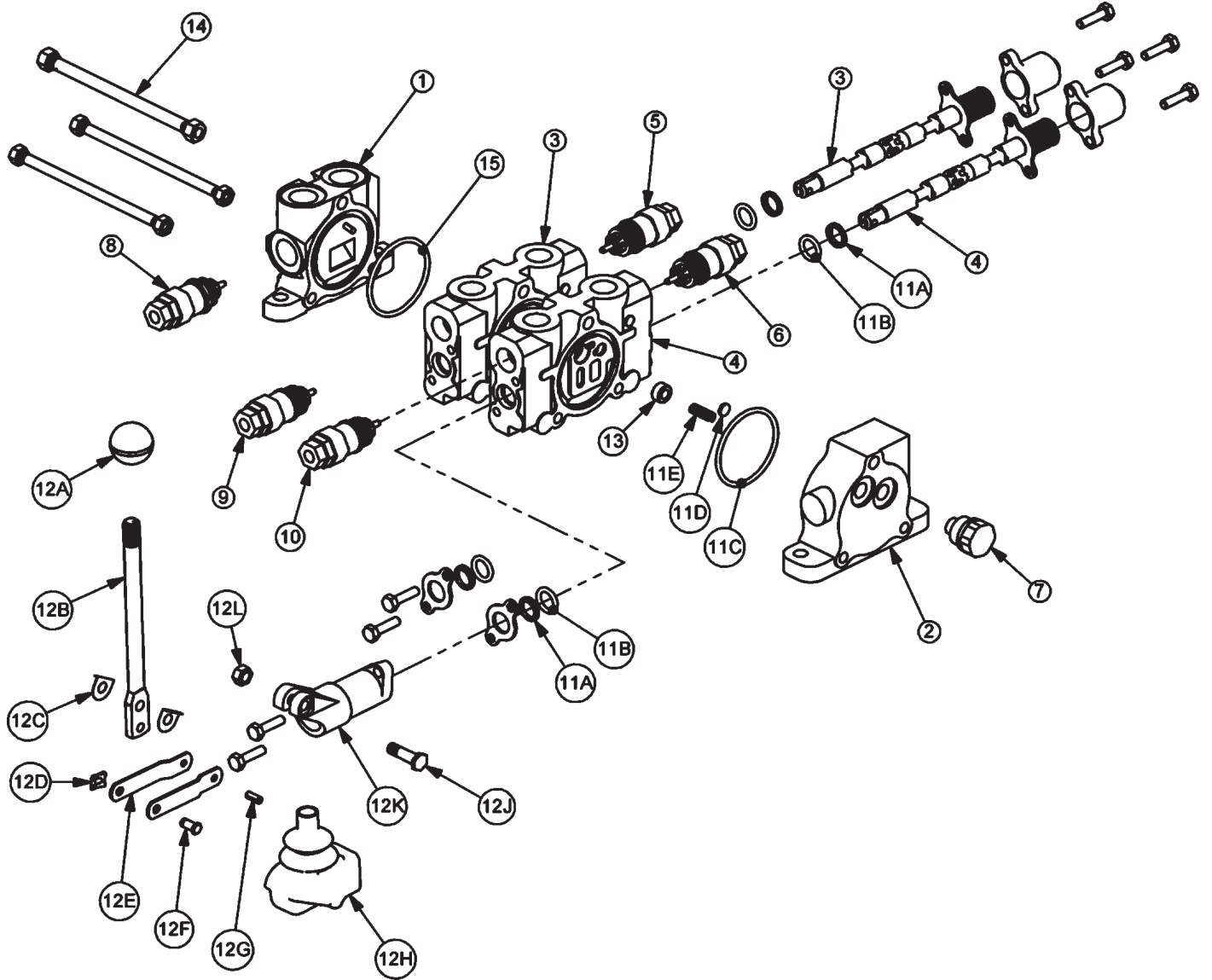

2SP HUSCO - LOAD SENSE (06502042)

ITEM	PART NO.	QTY	DESCRIPTION
1	31595	1	INLET END COVER
2	31594	1	END COVER, LOAD SENSE
3	31600	1	VALVE SECTION (DOUBLE ACTING, DETENT FLOAT)
4	31600	1	VALVE SECTION (DOUBLE ACTING, DETENT FLOAT) (REMOVE SHUTTLE DISC)
5	06503067	1	RELIEF PLUG
6	31861	1	RELIEF VALVE 360 PSI
7	06503068	1	RELIEF PLUG
8	6T4209	1	RELIEF PLUG
9	31862	1	RELIEF VALVE, 2175 PSI
10	31862	1	RELIEF VALVE, 2175 PSI
11	31593	2	VALVE SEAL KIT (FOR ONE SECTION)
11A		2	WIPER
11B		2	O-RING SMALL
11C		1	O-RING LARGE
11D		1	SHUTTLE DISC
11E		1	SPRING
12	TB1017L	2	LEVER KIT (FOR ONE SECTION)
12A		1	LEVER KNOB
12B		1	LEVER
12C		2	LEVER WASHER
12D		1	LEVER CLIP
12E		2	LINKAGE
12F		1	LEVER PIN
12G		1	ROLL PIN
12H		1	LEVER BOOT
12J		1	LEVER BOLT
12K		1	LEVER DUST COVER
12L		1	LEVER NUT
13	31603	2	COMPENSATOR
14	TB1017X	1	TIE ROD KIT
15	24214	1	O-RING, LARGE

2SP HUSCO - LOAD SENSE (31320)

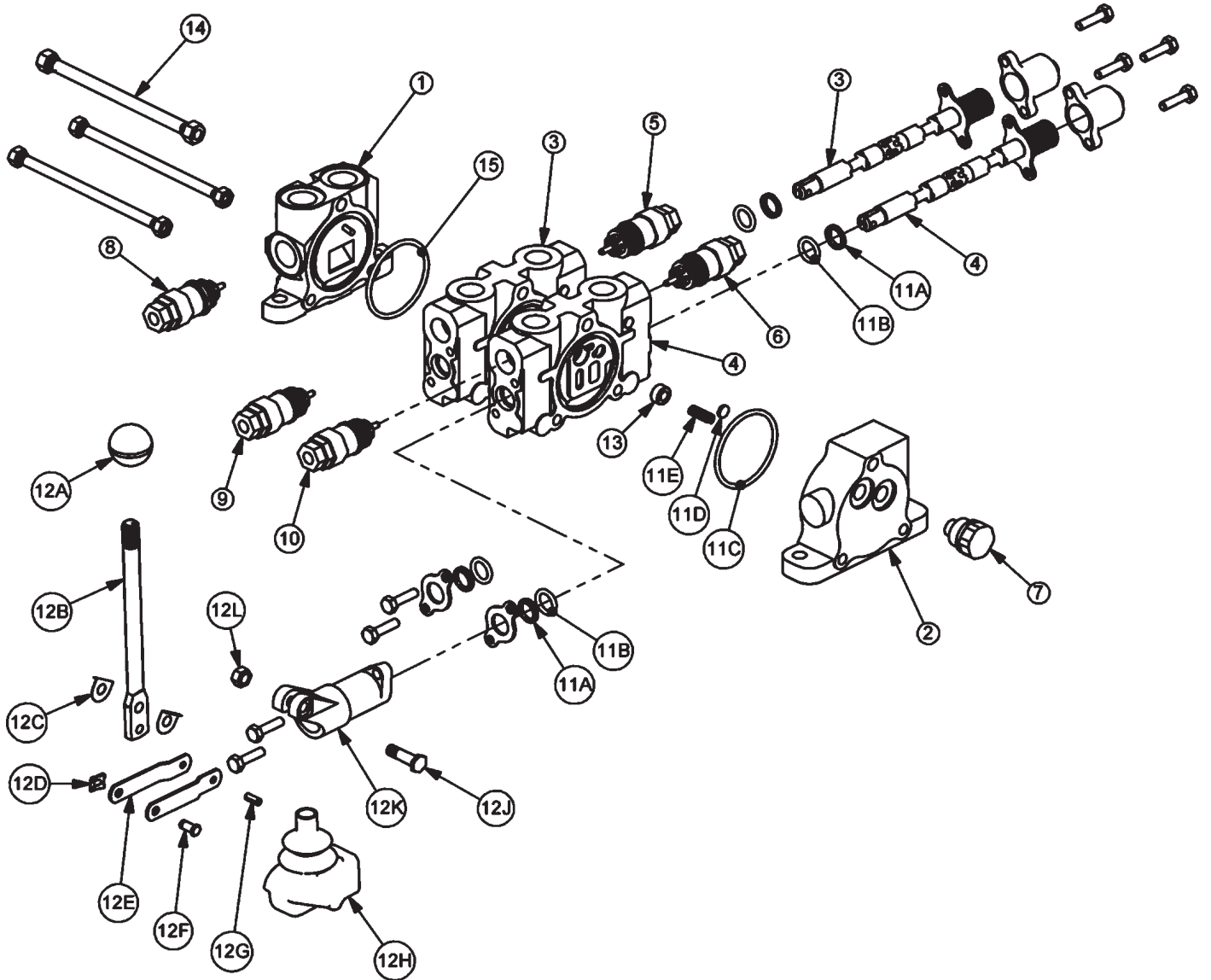

2SP HUSCO - LOAD SENSE (31320)

ITEM	PART NO.	QTY	DESCRIPTION
1	31595	1	INLET END COVER
2	31594	1	END COVER, LOAD SENSE
3	31597	1	VALVE SECTION (DOUBLE ACTING, CENTER SPRING)
4	31597	1	VALVE SECTION (DOUBLE ACTING, CENTER SPRING)
5	06503067	1	RELIEF PLUG
6	06503067	1	RELIEF PLUG
7	N/A	-	N/A
8	6T4209	1	RELIEF PLUG
9	31862	1	RELIEF VALVE, 2175 PSI
10	31862	1	RELIEF VALVE, 2175 PSI
11	31593	2	VALVE SEAL KIT (FOR ONE SECTION)
11A		2	WIPER
11B		2	O-RING SMALL
11C		1	O-RING LARGE
11D		1	SHUTTLE DISC
11E		1	SPRING
12	TB1017L	2	LEVER KIT (FOR ONE SECTION)
12A		1	LEVER KNOB
12B		1	LEVER
12C		2	LEVER WASHER
12D		1	LEVER CLIP
12E		2	LINKAGE
12F		1	LEVER PIN
12G		1	ROLL PIN
12H		1	LEVER BOOT
12J		1	LEVER BOLT
12K		1	LEVER DUST COVER
12L		1	LEVER NUT
13	31603	2	COMPENSATOR
14	TB1017X	1	TIE ROD KIT
15	24214	1	O-RING, LARGE

2SP HUSCO - LOAD SENSE (31322)

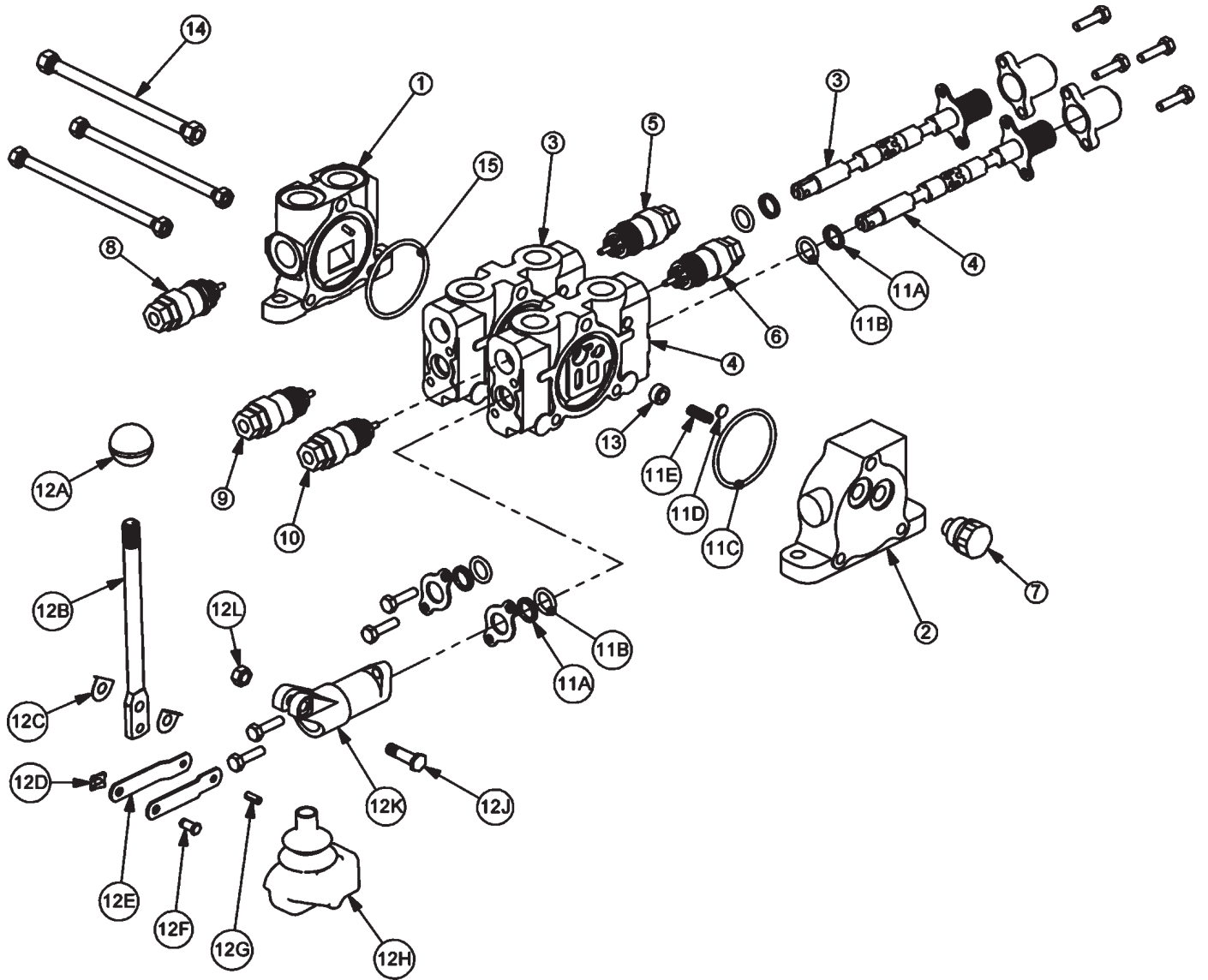

2SP HUSCO - LOAD SENSE (31322)

ITEM	PART NO.	QTY	DESCRIPTION
1	31595	1	INLET END COVER
2	31594	1	END COVER, LOAD SENSE
3	31600	1	VALVE SECTION (DOUBLE ACTING, DETENT - FLOAT)
4	31600	1	VALVE SECTION (DOUBLE ACTING, DETENT - FLOAT)
5	06503067	1	RELIEF PLUG
6	31861	1	RELIEF VALVE, 360 PSI
7	N/A	-	N/A
8	6T4209	1	RELIEF PLUG
9	31862	1	RELIEF VALVE, 2175 PSI
10	31862	1	RELIEF VALVE, 2175 PSI
11	31593	2	VALVE SEAL KIT (FOR ONE SECTION)
11A		2	WIPER
11B		2	O-RING SMALL
11C		1	O-RING LARGE
11D		1	SHUTTLE DISC
11E		1	SPRING
12	TB1017L	2	LEVER KIT (FOR ONE SECTION)
12A		1	LEVER KNOB
12B		1	LEVER
12C		2	LEVER WASHER
12D		1	LEVER CLIP
12E		2	LINKAGE
12F		1	LEVER PIN
12G		1	ROLL PIN
12H		1	LEVER BOOT
12J		1	LEVER BOLT
12K		1	LEVER DUST COVER
12L		1	LEVER NUT
13	31603	2	COMPENSATOR
14	TB1017X	1	TIE ROD KIT
15	24214	1	O-RING, LARGE

2SP HUSCO - POWER BEYOND (30198)

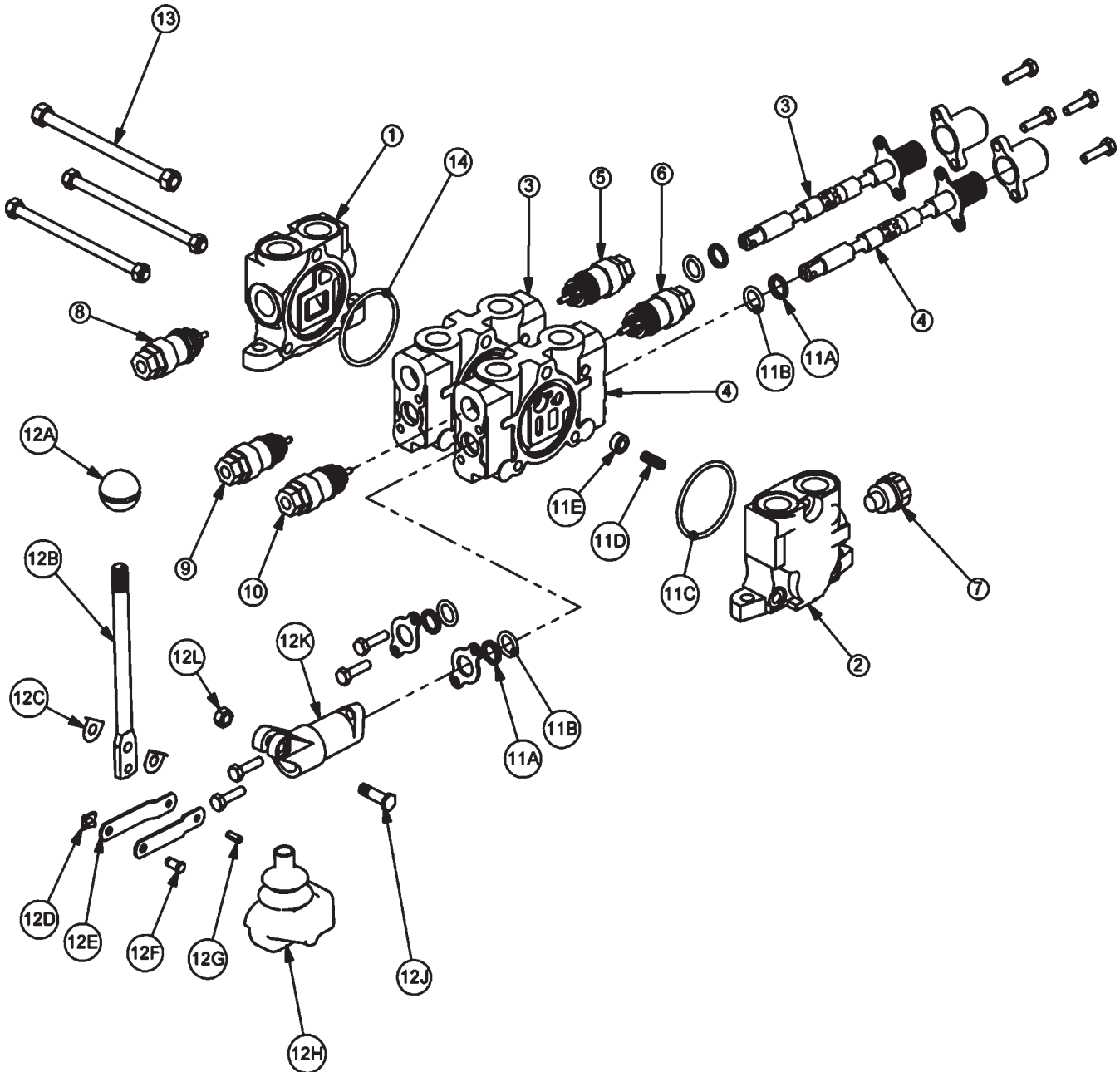

2SP HUSCO - POWER BEYOND (30198)

ITEM	PART NO.	QTY	DESCRIPTION
1	TB1017S	1	INLET END COVER
2	TB1702	1	END COVER, POWER BEYOND
3	TF3009	1	VALVE SECTION (DOUBLE ACTING, DETENT - FLOAT)
4	TF3009	1	VALVE SECTION (DOUBLE ACTING, DETENT - FLOAT)
5	06503067	1	RELIEF PLUG
6	TF4212	1	RELIEF VALVE, 200 PSI
7	TB1017M	1	SHUT-OFF PLUG
8	TB1017E	1	RELIEF VALVE, 2250 PSI
9	TB1017M	1	SHUT-OFF PLUG
10	TB1017M	1	SHUT-OFF PLUG
11	TB1017A	2	VALVE SEAL KIT (FOR ONE SECTION)
11A		2	WIPER
11B		2	O-RING SMALL
11C		1	O-RING LARGE
11D		1	SPRING
11E		1	PUCKET
12	TB1017L	2	LEVER KIT (FOR ONE SECTION)
12A		1	LEVER KNOB
12B		1	LEVER
12C		2	LEVER WASHER
12D		1	LEVER CLIP
12E		2	LINKAGE
12F		1	LEVER PIN
12G		1	ROLL PIN
12H		1	LEVER BOOT
12J		1	LEVER BOLT
12K		1	LEVER DUST COVER
12L		1	LEVER NUT
13	TB1017X	1	TIE ROD KIT
14	24214	1	O-RING, LARGE

2SP HUSCO - POWER BEYOND (30801)

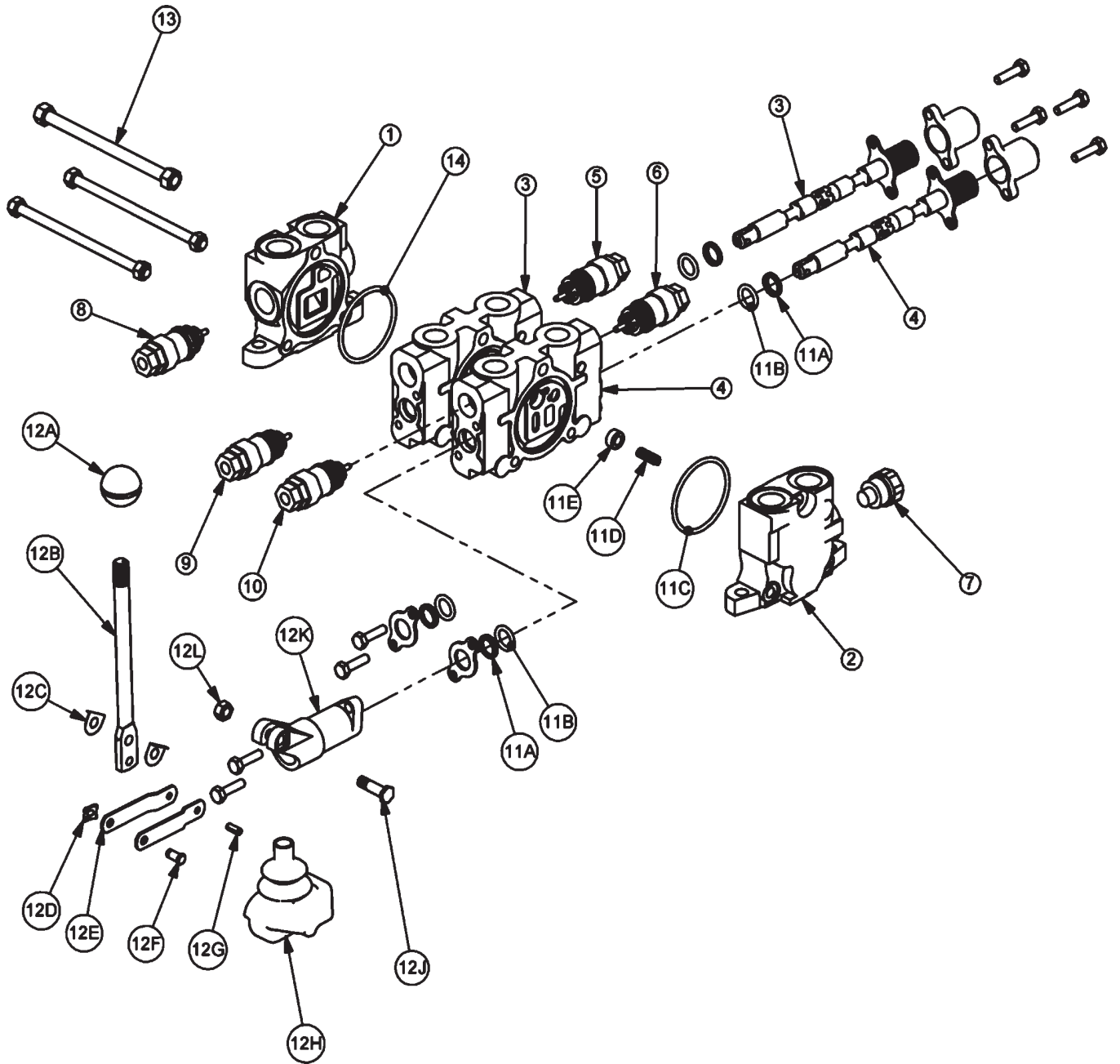

2SP HUSCO - POWER BEYOND (30801)

ITEM	PART NO.	QTY	DESCRIPTION
1	TB1017S	1	INLET END COVER
2	TB1702	1	END COVER, POWER BEYOND
3	TB1017P	1	VALVE SECTION (SINGLE ACTING, SPRING DETENT)
4	06502091	1	VALVE SECTION (DOUBLE ACTING, CENTER SPRING) (NO AUX VALVE PORTS)
5	N/A	-	N/A
6	N/A	-	N/A
7	TB1017M	1	SHUT-OFF PLUG
8	TB1017E	1	RELIEF VALVE, 2250 PSI
9	TB1017M	1	SHUT-OFF PLUG
10	N/A	-	N/A
11	TB1017A	2	VALVE SEAL KIT (FOR ONE SECTION)
11A		2	WIPER
11B		2	O-RING SMALL
11C		1	O-RING LARGE
11D		1	SPRING
11E		1	PUCKET
12	TB1017L	2	LEVER KIT (FOR ONE SECTION)
12A		1	LEVER KNOB
12B		1	LEVER
12C		2	LEVER WASHER
12D		1	LEVER CLIP
12E		2	LINKAGE
12F		1	LEVER PIN
12G		1	ROLL PIN
12H		1	LEVER BOOT
12J		1	LEVER BOLT
12K		1	LEVER DUST COVER
12L		1	LEVER NUT
13	TB1017X	1	TIE ROD KIT
14	24214	1	O-RING, LARGE

2SP HUSCO - POWER BEYOND (31752)

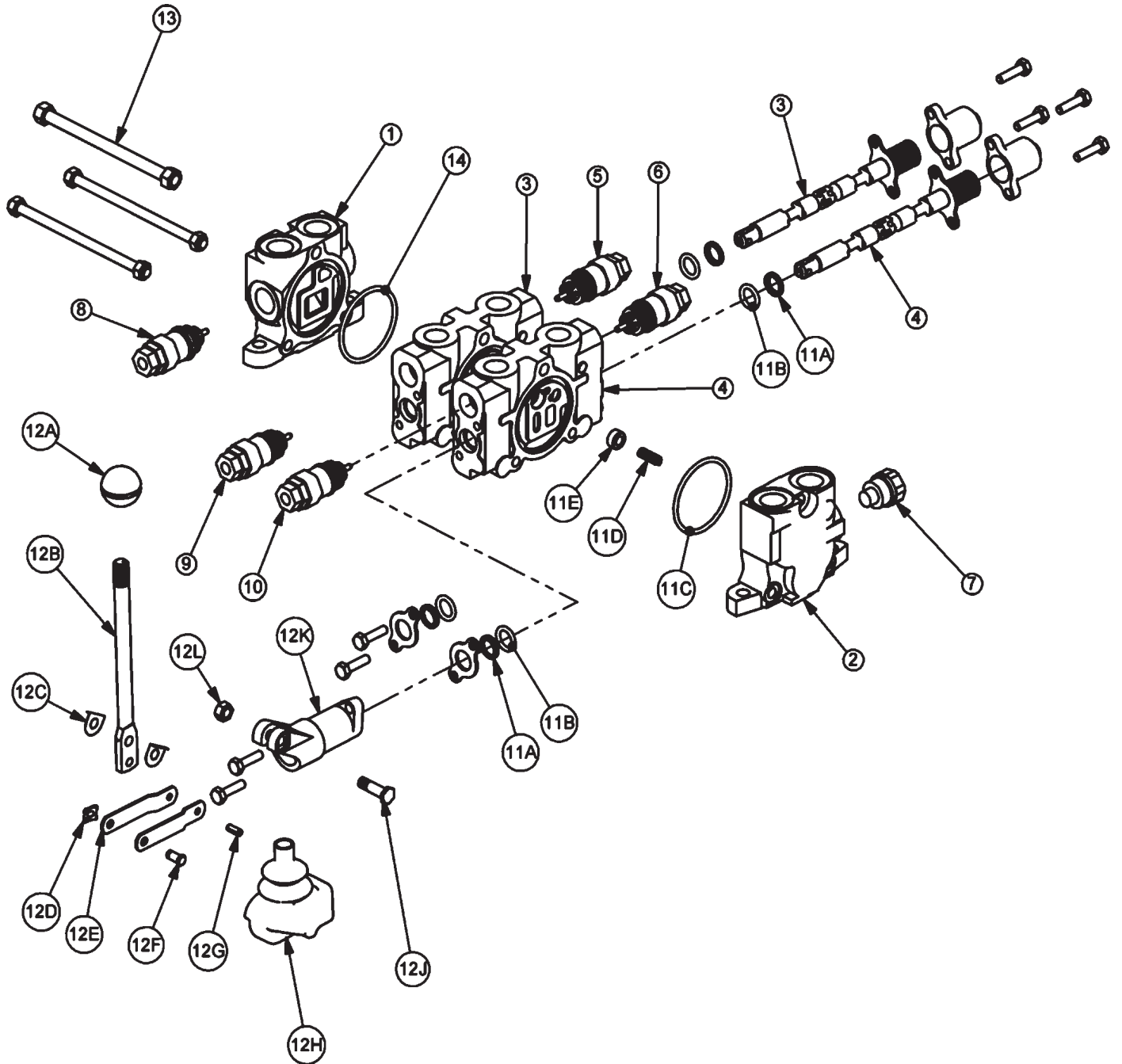

2SP HUSCO - POWER BEYOND (31752)

ITEM	PART NO.	QTY	DESCRIPTION
1	TB1017S	1	INLET END COVER
2	TB1702	1	END COVER, POWER BEYOND
3	TB1017P	1	VALVE SECTION (SINGLE ACTING, SPRING DETENT)
4	TB1017P	1	VALVE SECTION (SINGLE ACTING, SPRING DETENT)
5	N/A	-	N/A
6	N/A	-	N/A
7	TB1017M	1	SHUT-OFF PLUG
8	TB1017E	1	RELIEF VALVE, 2250 PSI
9	TB1017M	1	SHUT-OFF PLUG
10	TB1017M	1	TB1017M
11	TB1017A	2	VALVE SEAL KIT (FOR ONE SECTION)
11A		2	WIPER
11B		2	O-RING SMALL
11C		1	O-RING LARGE
11D		1	SPRING
11E		1	PUCKET
12	TB1017L	2	LEVER KIT (FOR ONE SECTION)
12A		1	LEVER KNOB
12B		1	LEVER
12C		2	LEVER WASHER
12D		1	LEVER CLIP
12E		2	LINKAGE
12F		1	LEVER PIN
12G		1	ROLL PIN
12H		1	LEVER BOOT
12J		1	LEVER BOLT
12K		1	LEVER DUST COVER
12L		1	LEVER NUT
13	TB1017X	1	TIE ROD KIT
14	24214	1	O-RING, LARGE

FRONT HYDRAULIC PUMP – HIGH PRESSURE

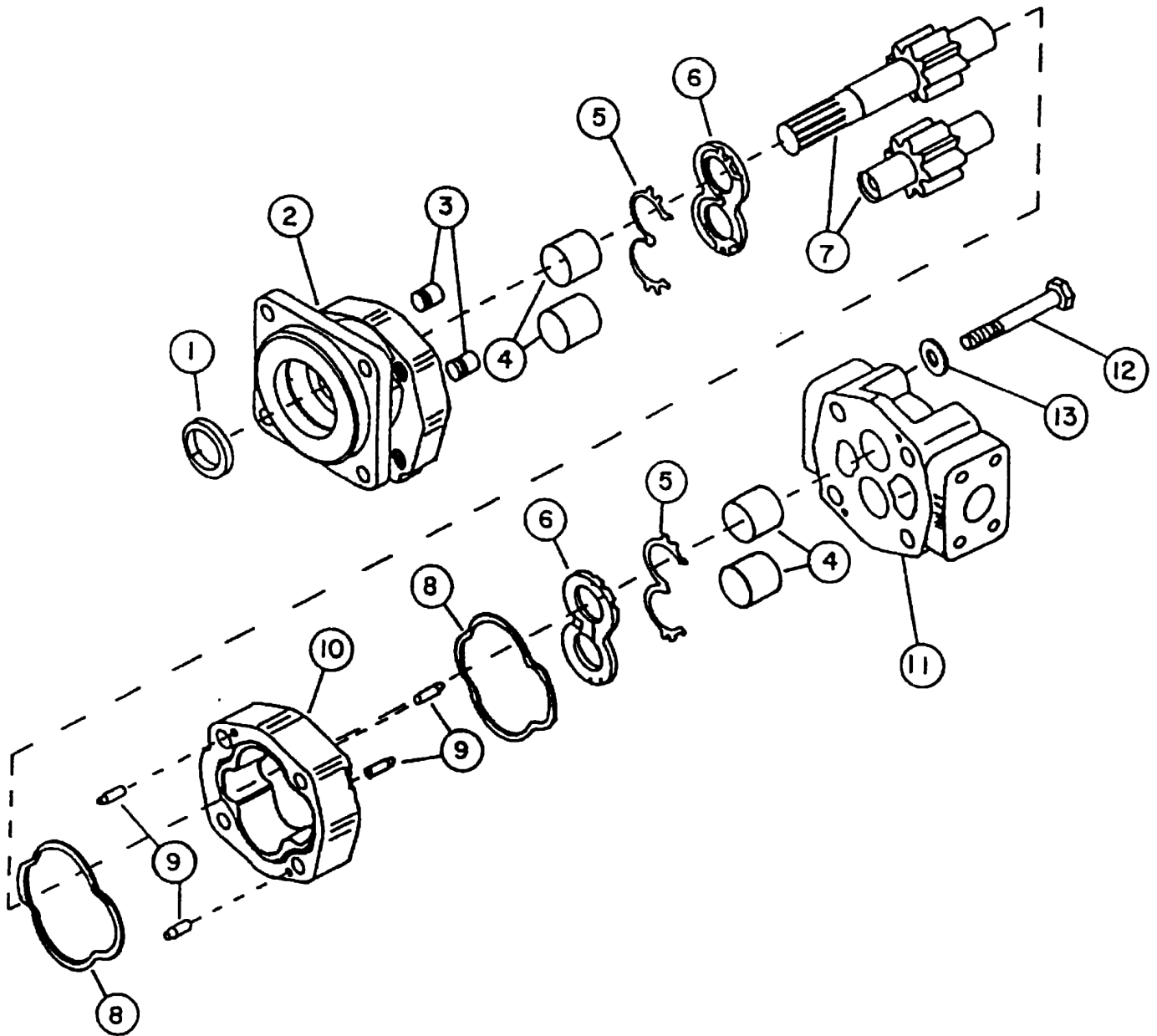

FRONT HYDRAULIC PUMP – HIGH PRESSURE

ITEM	PART NO.	QTY.	DESCRIPTION
*	23152	AVAIL	PUMP ASSEMBLY 1 3/4" COMPLETE
1	22765	1	SEAL (INCLUDED IN SEAL KIT)
2	22766	1	SHAFT END COVER
3	22767	2	CHECK AND END COVER
4	22768	2	BUSHING
5	22769	2	CHANNEL SEAL (INCLUDED IN SEAL KIT)
6	22770	2	THRUST PLATE (INCLUDED IN SEAL KIT)
7	22771	SET	DRIVE SHAFT AND GEAR SET 1 3/4"
8	22772	2	GASKET SEAL (INCLUDED IN SEAL KIT)
9	22773	4	DOWEL PINS
10	22774	1	GEAR HOUSING 1 3/4"
11	22779	1	PORT END COVER
12	23824	4	STUDS
13	22781	SET	WASHER
	6T5322	AVAIL	SEAL APPLICATOR TOOL
	24150	AVAIL	SEAL KIT (INCLUDES 1, 5, 6 AND 8)

FLAIL MOTOR – HIGH PRESSURE

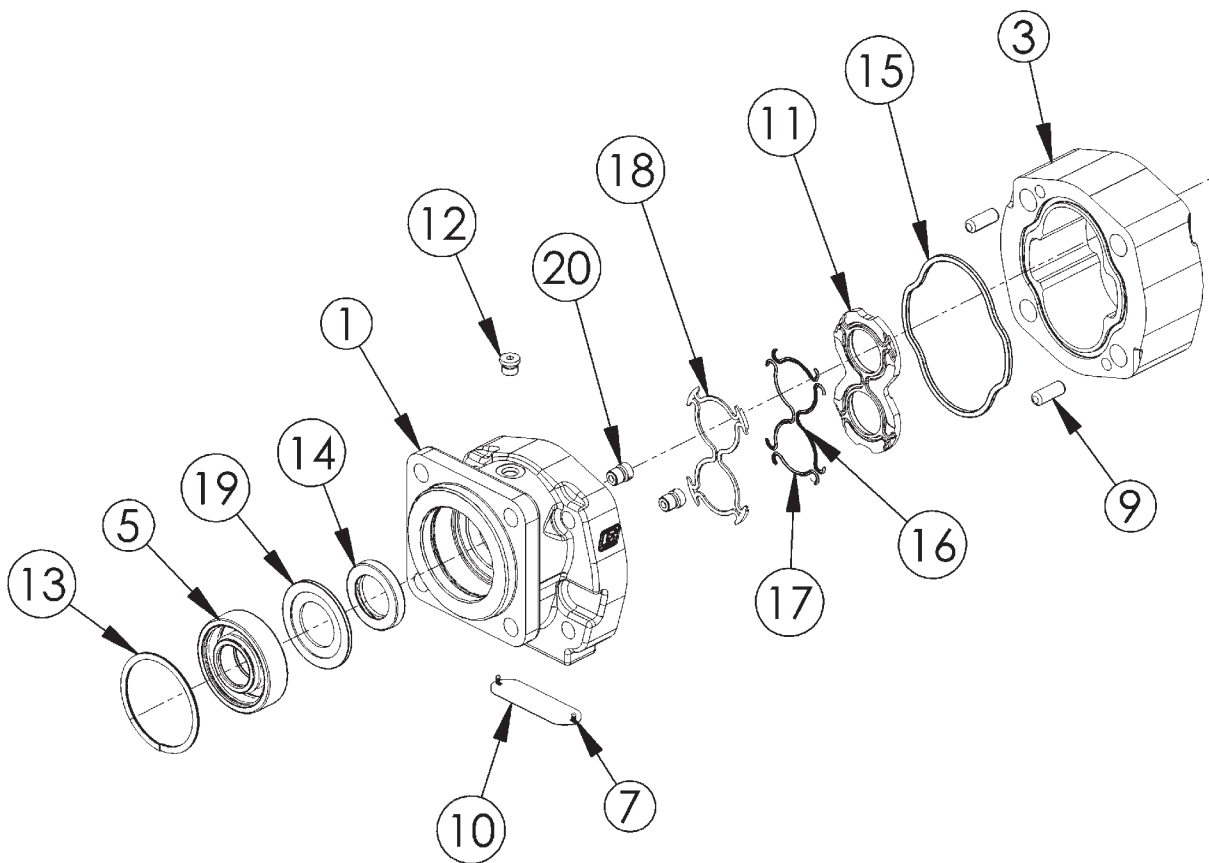
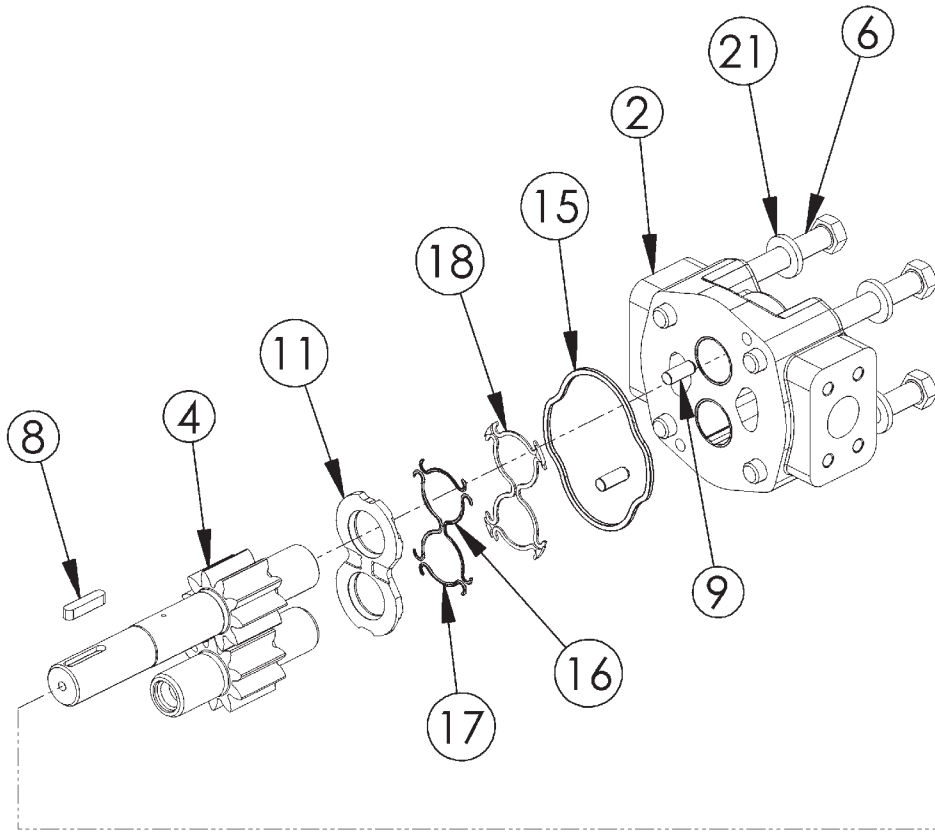

FLAIL MOTOR – HIGH PRESSURE

ITEM	PART NO.	QTY.	DESCRIPTION
*	06504013	AVAIL	MOTOR ASSEMBLY 350 - TSF
1	06504039	1	SHAFT END COVER
2	06504040	1	PORT END COVER
3	06504041	1	GEAR HOUSING
4	06504042	1	MATCHED GEAR SET
5	TF4402	1	BALL BEARING
6	06504043	4	CAP SCREW
7	06504044	2	SET SCREW
8	06504028	1	KEY
9	06504045	4	DOWEL PIN
10		1	NAMEPLATE
11	763759	2	THRUSTPLATE
12	02961940	1	HEX PLUG
13	TF4401	1	SNAP RING
14	06504049	1	LIP SEAL (INCLUDED IN SEAL KIT)
15	TF4410	2	GASKET SEAL (INCLUDED IN SEAL KIT)
16	06504046	4	SIDE SEAL (INCLUDED IN SEAL KIT)
17	06504047	4	END SEAL (INCLUDED IN SEAL KIT)
18	TF4407	2	BACK-UP SEAL (INCLUDED IN SEAL KIT)
19	06504048	1	SEAL RETAINER
20	6T5809	2	CHECK ASSEMBLY
21	02961917	4	WASHER
*	06504023	AVAIL	SEAL KIT (INCLUDES 14, 15, 16, 17, AND 18)

SIDE COOLER

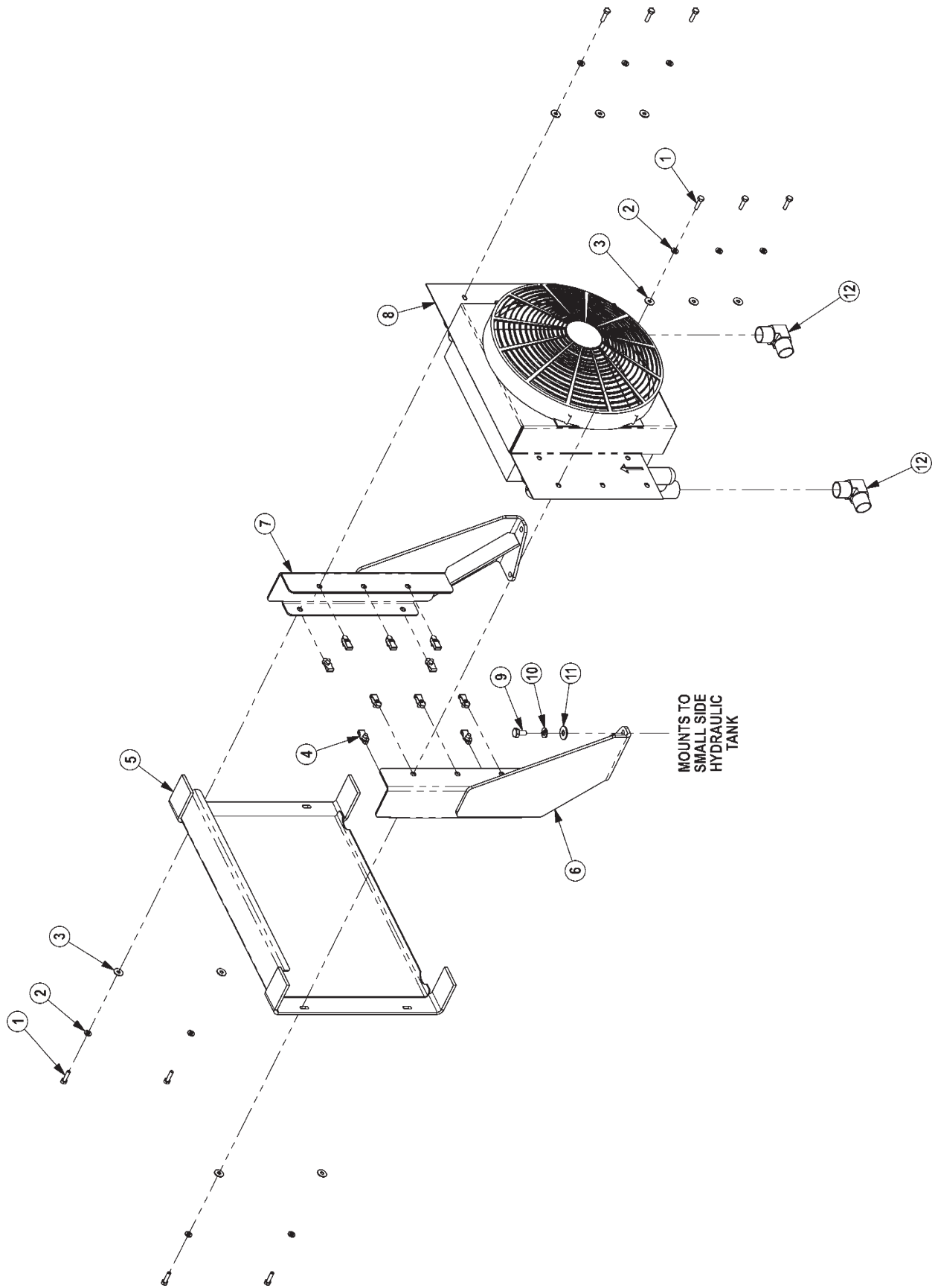

SIDE COOLER

ITEM	PART NO.	QTY.	DESCRIPTION
1	21530	10	CAPSCREW,1/4 X1 NC
2	21986	10	LOCKWASHER,1/4
3	22014	10	FLATWASHER,1/4
4	35176	10	1/4 U-NUT
5	06370015	1	SCREEN,COOLER,FRNT
6	06380006	1	MNT,COOLER,BUMPER TANK,RH
7	06380007	1	MNT,COOLER,BUMPER TANK,LH
8	06510026	1	COOLER,FRONT MNT
9	21629	4	CAPSCREW,3/8 X 3/4 NC
10	21988	4	LOCKWASHER,3/8
11	22016	4	FLATWASHER,3/8
12	34117	2	ELBOW,1MOR X 1MJ90,FORGED

BRAKE VALVE ASSEMBLY W/ METRI PAK

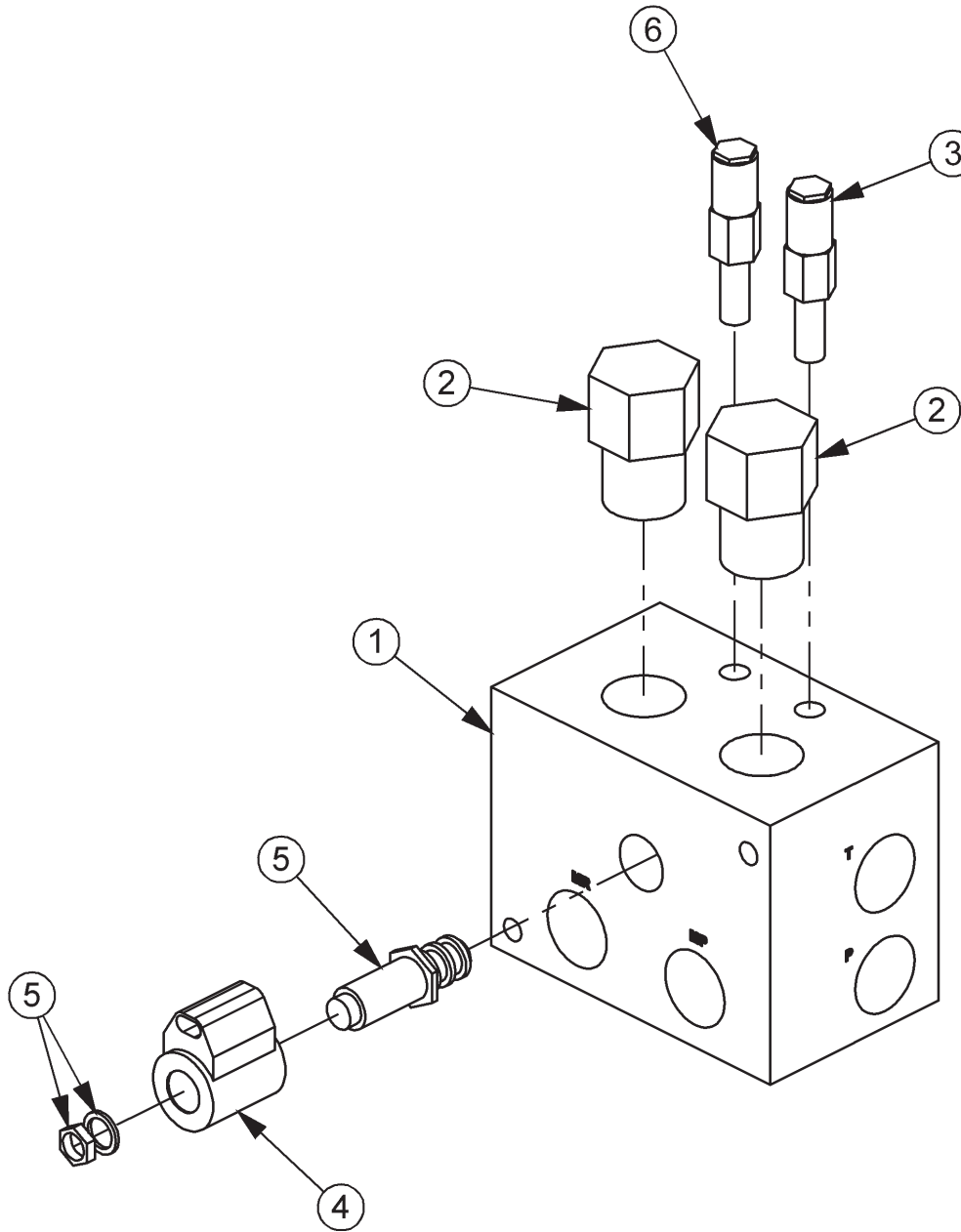

ITEM	PART NO.	QTY.	DESCRIPTION
1	34092	1	BRAKE VALVE, BLANK
2	34094	2	LOGIC ELEMENT
3	34095	1	RELIEF VALVE, 3500 PSI
4	06510095	1	METRI PAK COIL
5	34093	1	CARTRIDGE, 2 POSITION, 3 WAY (WITH NUT & WASHER)
6	34091	1	RELIEF VALVE, 2600 PSI

SOLENOID BRAKE VALVE HYDRAULIC SCHEMATIC

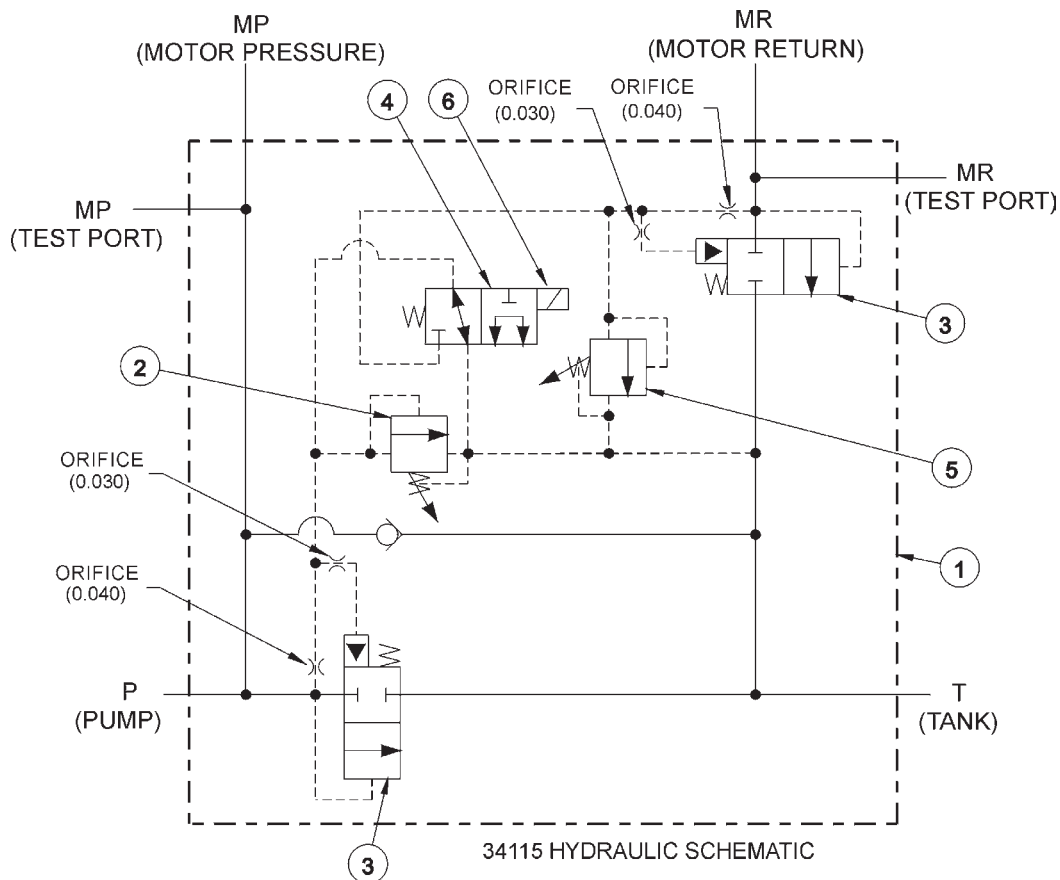

BRAKE VALVE TROUBLESHOOTING

FAILURE MODE:

- MOWER WILL NOT START - system pressure is low (engine not lugging).
- MOWER WILL NOT START - system pressure is high (engine lugging). "MR" port will be high pressure.
- MOWER WILL NOT ROTATE AT FULL SPEED - limited power.
- MOWER BLADE WILL NOT STOP - blade will not stop in proper time.

CHECK STEPS

- 1 thru 6
- 7
- 3 thru 5
- 7 thru 9

CORRECTIVE STEPS:

1. Check for voltage at solenoid (item 6), voltage must be between 10.2 volts and 13.8 volts.
2. Remove, inspect solenoid and cartridge (items 4, 6) for wear or contamination.
3. Remove, inspect logic elements near "P" port (item 3) for wear or contamination.
4. Remove, inspect 3000 psi relief valve (item 2) for wear or contamination.
5. Remove and inspect orifices near "P" port for contamination.
6. Remove "P" port hose and fitting, visually inspect for contamination, check ball for movement.
7. Remove and inspect orifices near "MR" port for contamination.
8. Remove, inspect 2600 psi relief valve (item 5) for wear of contamination.
9. Remove, inspect logic element near "MR" port (item 3) for wear or contamination.

SIDE FLAIL TRAVEL LOCK

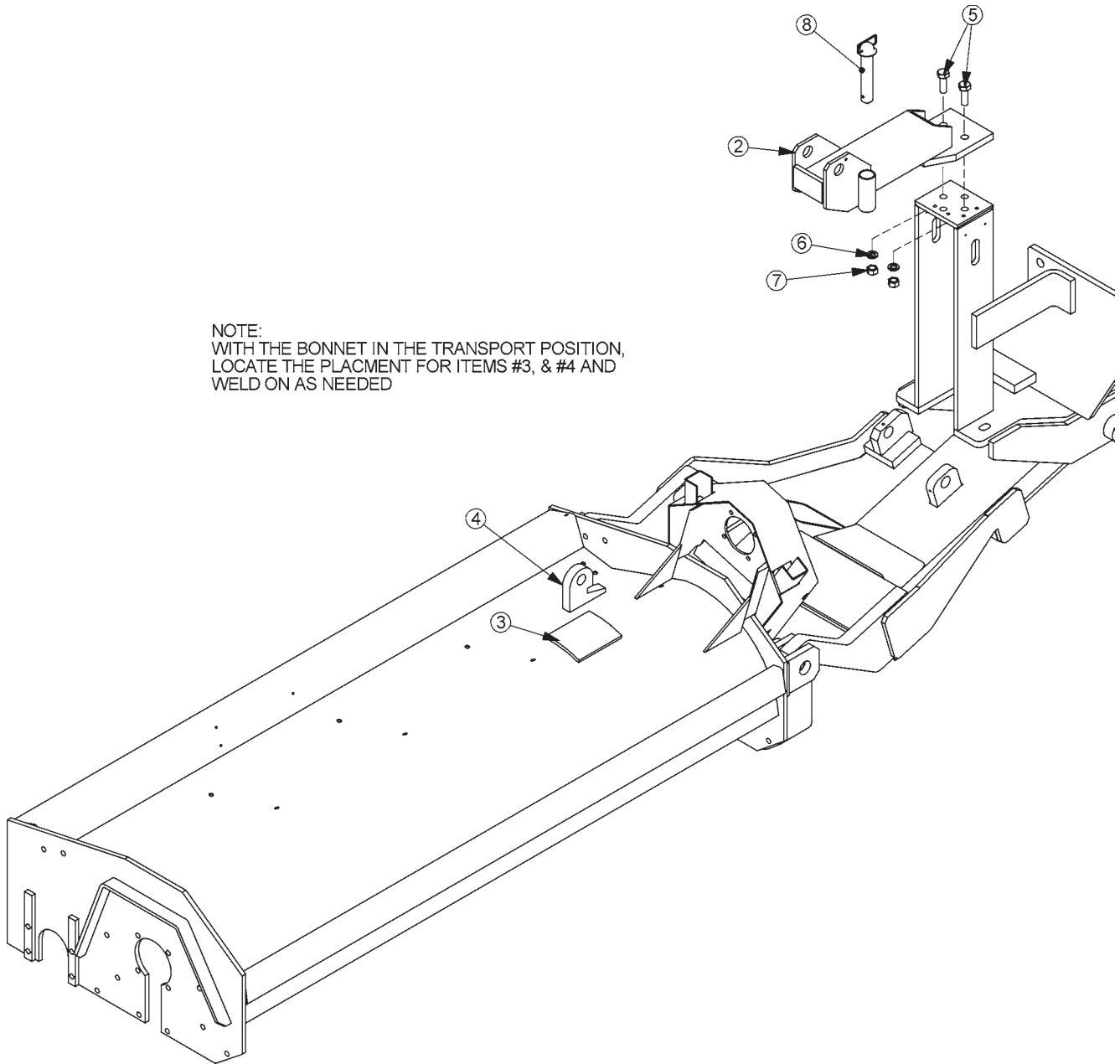

NOTE:
WITH THE BONNET IN THE TRANSPORT POSITION,
LOCATE THE PLACEMENT FOR ITEMS #3, & #4 AND
WELD ON AS NEEDED

ITEM	PART NO.	QTY.	DESCRIPTION
*	REF	*	BONNET (REFER TO HEAD PARTS)
2	30531A	1	BRACKET, TRAVEL LOCK
3	TF4248	1	PLATE, TRAVEL LOCK
4	23745	1	TRAVEL LOCK HOOK
5	21783	2	CAPSCREW, 5/8"x2" NC
6	21992	2	LOCKWASHER, 5/8"
7	21775	2	HEX NUT, 5/8" NC
8	TF4250	1	PIN, TRAVEL LOCK

TRAVEL LOCK LIFT BEAM

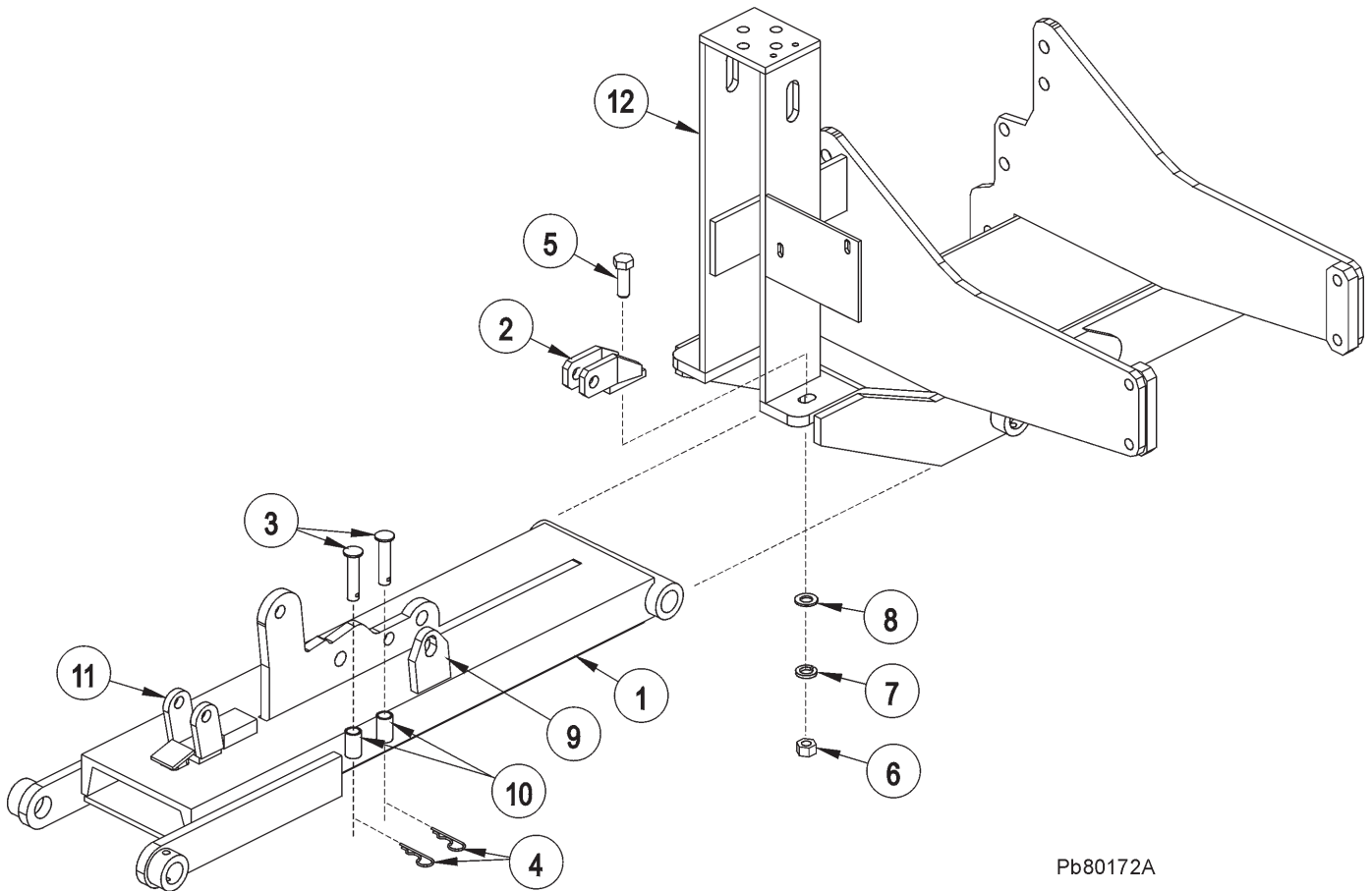

Pb80172A

ITEM	PART NO.	QTY.	DESCRIPTION
1	6T0105	1	DRAFT BEAM (STD WITH TRAVEL LOCKS)
2	6T0106	1	TRAVEL LOCK BRACKET
3	6T0107	2	TRAVEL LOCK PINS 3/4" X 3 1/4"
4	6T3020	2	R - CLIP 5/32"
5	21833	1	CAPSCREW 3/4" X 2 1/4"
6	21825	1	HEX NUT 3/4"
7	21993	1	LOCK WASHER 3/4"
8	22021	1	FLAT WASHER 3/4"
9	22600	1	TRAVEL LOCK EAR
10	22604	2	PIN HOLDER
11	22601C	1	TRAVEL LOCK ASY
12	*	REF.	MAIN FRAME REFER TO PARTS SECTION

SWITCHBOX SERVICE PARTS

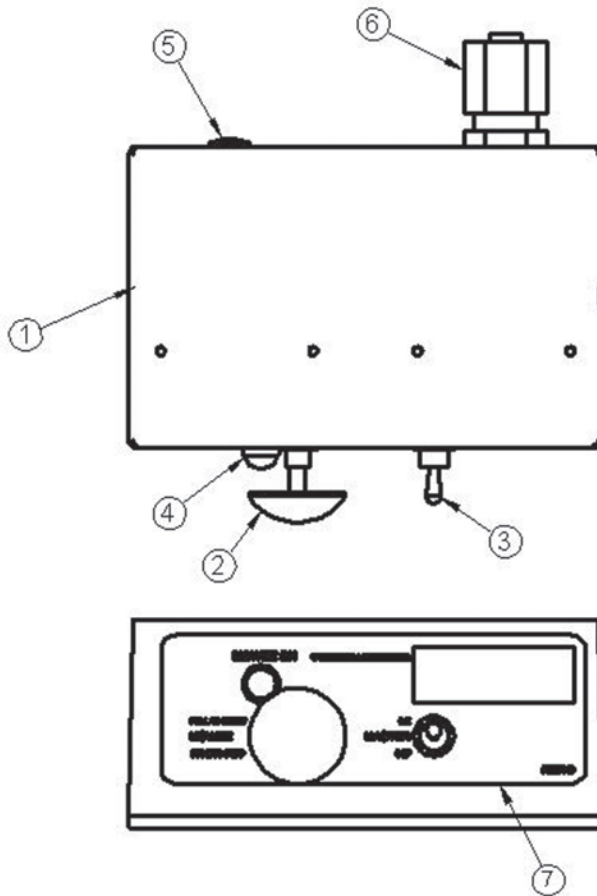
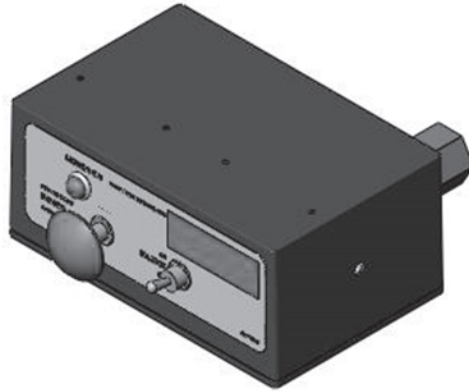

ITEM	P/N	QTY.	DESCRIPTION
1	06514013	1	SWBX,ALUM,BLK,06510102
2	35226	1	SWITCH,MOWER,COLEHERSEE
3	33811	1	SWITCH,MASTER/DECK FLOAT
4	6T3923	1	INDICTATOR LIGHT,ON,RED
5	06514014	1	BREAKER,10A,SWBX
6	34540	1	STRAIN RELIEF,3/4,BLACK,NYLON
7	06550018	1	DECAL,SWTCHBX,TM/TSF,CG
8	35227	1	RELAY,DP,DT,12V,LY2F,35226

SWITCHBOX SCHEMATIC

06510102 SCHEMATIC COMMON GROUND SWITCH BOX SIDE MOWER

NOTE:
ADD METRIPAK 150
FEMALE PLUG (MALE PINS)
W/JUMPER WIRES

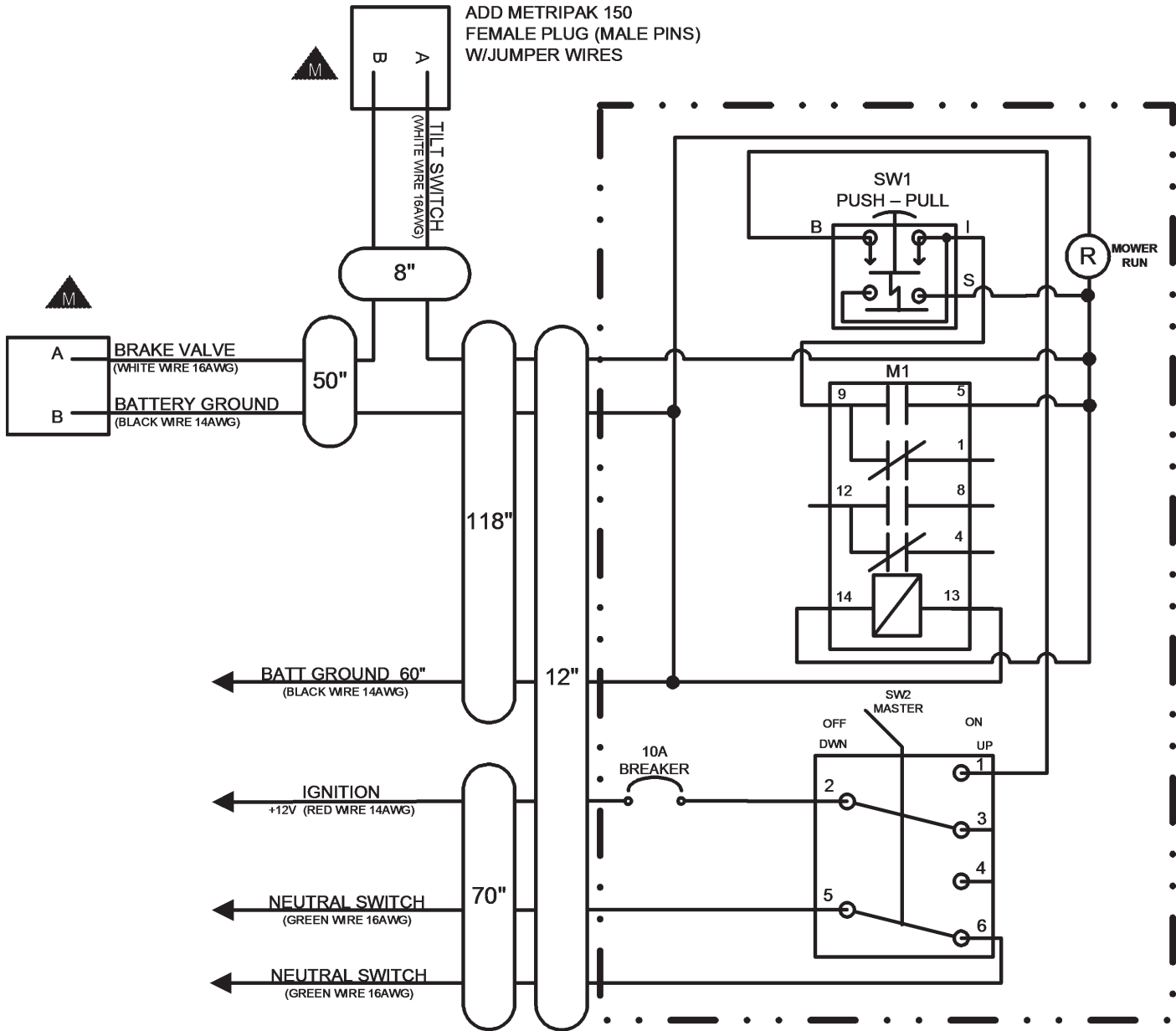

SEE DRAWING # 06515000 FOR A FULL DESCRIPTION OF ALL CONNECTORS

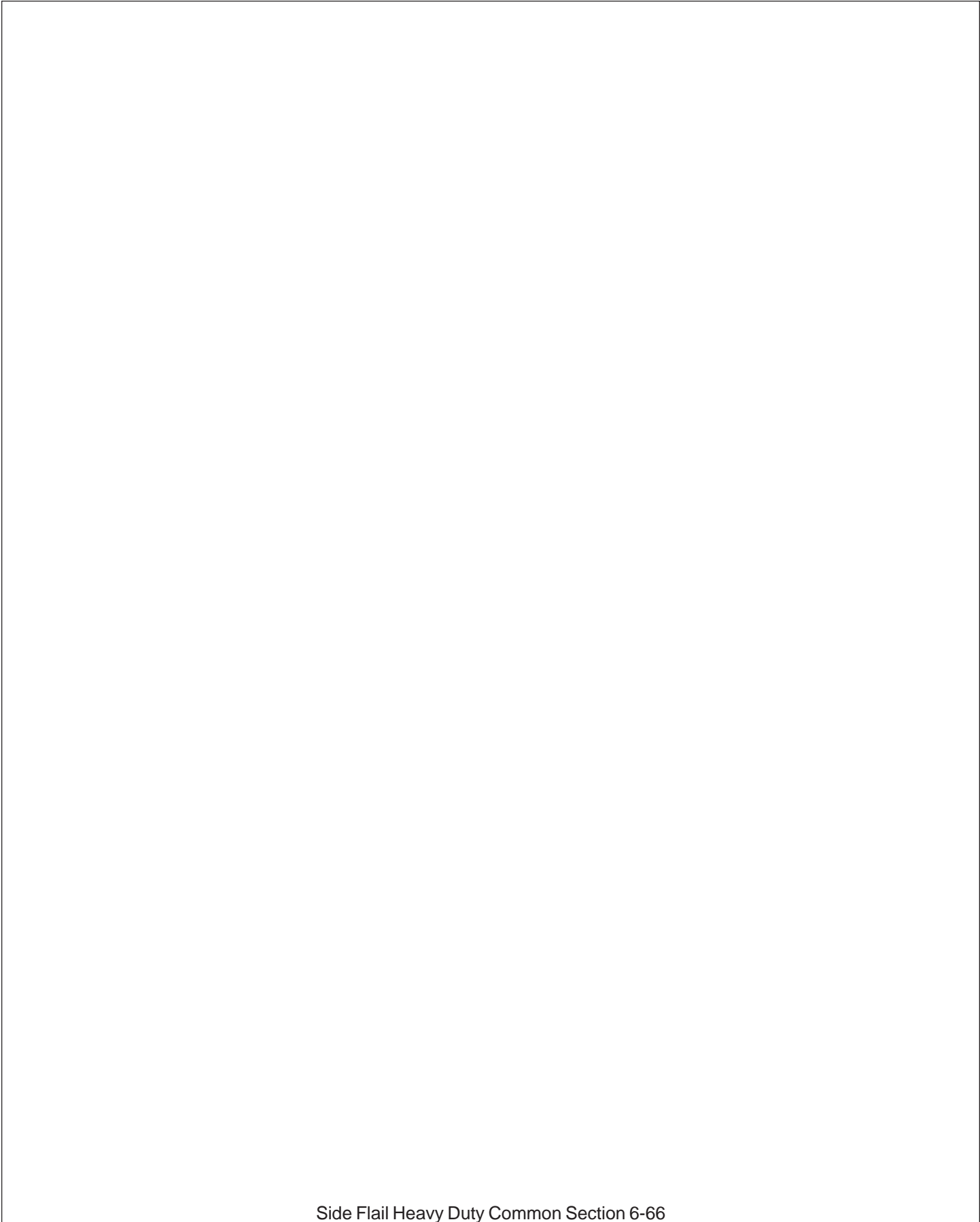

WARRANTY SECTION

WARRANTY INFORMATION

Tiger Corporation, 3301 N. Louise, Sioux Falls, South Dakota, warrants to the original Retail Customer, the new Tiger equipment is free of defects in material and workmanship. Any part of equipment that in Tiger's judgement, show evidence of such defects will be repaired or replaced without charge, provided that the failure of part(s) shall have occurred within twelve (12) months from the date of delivery of said equipment to the Retail Customer. Expendable components such as knives, oil, chain sprockets, skid shoes, knife mounting disks and the like are excluded but not limited to this warranty.

The Retail Customer must pay the transportation cost to and from the Tiger Dealer's service shop for warranty service. Warranty service will be performed by the Tiger Dealer from whom the equipment was purchased, during service shop regularly scheduled days and hours of operation.

All Tiger obligation under this warranty shall be terminated if the equipment is modified or altered in ways not approved in writing by Tiger, if repair parts other than genuine Tiger repair parts have been used, or if the equipment has been subject to misuse, neglect, accident, improper maintenance or improper operation.

Tiger Corporation reserves the right to make improvements in design or changes in specification at any time without incurring any obligation to owners of equipment previously sold.

No agent or person has authority to alter, add to or waive the above warranties which are agreed to be in the only warranties, representations or promises, expressed or implied, as to the quality or performance of the products covered and which do not include any implied warranty of merchantability or fitness. In no event will Tiger be liable for incidental or consequential damages or injuries, including, but not limited to, loss of profits, rental or substitute equipment or other commercial loss.

**THERE ARE NO WARRANTIES WHICH EXTEND
BEYOND THOSE EXPRESSED HEREIN.**

It is the Purchasers obligation to sign the warranty registration form **AFTER** he / she has Read and Understands the Operation and Safety Instructions stated within this manual.

ONE LAST WORD

This manual cannot possibly cover all of the potentially hazardous situations you will encounter. By being familiar with the safety rules, operating and maintenance instructions in this manual you can help prevent accidents. The objective of this manual is to help make you a better operator. Remember, **SAFETY IS YOU!**



1012

Your safety and the safety of those around you depends on **YOU**. Common sense should play a large role in the operation of this machine.

Since we at Tiger Corporation are constantly striving to improve our products, we reserve the right to change specifications or design at any time.

TO THE OWNER / OPERATOR / DEALER



To keep your implement running efficiently and safely, read your manual thoroughly and follow these directions and the Safety Messages in this manual and on the machine. The table of contents clearly identifies each section where you can easily find the information you need.

The Occupational Safety and Health Act (OSHA 1928.51 subpart C) makes the following minimum requirements for tractor operators.

OWNER REQUIREMENTS:

1. Provide a Roll-Over-Protective Structure that meets the requirements of this Standard; and
2. Provide Seatbelts that meet the requirements of this Standard and SAE J3C; and
3. Ensure that each employee uses such Seatbelt while the tractor is moving; and
4. Ensure that each employee tightens the Seatbelt sufficiently to confine the employee to the protected area provided by the ROPS.

OPERATOR REQUIREMENTS:

1. Securely fasten seatbelt if the tractor has a ROPS.
2. Where possible, avoid operating the tractor near steep ditches, embankments, and holes.
3. Reduce speed when turning, crossing slopes, and on rough, slick, or muddy surfaces.
4. Stay off slopes too steep for safe operation.
5. Watch where you are going – especially at row ends, on roads, and around trees.
6. Do Not permit others to ride.
7. Operate the tractor smoothly – no jerky turns, starts, or stops.
8. Hitch only to the draw-bar and hitch points recommended by the tractor manufacturer.
9. When the tractor is stopped, set brakes securely and use park lock, if available



Printed in USA
© Tiger Corporation