



# FLX15 FLX10 FLEX ARM

Published 2006-05-30

S/N A10100128508 - A10100152509

Part No. A101TG010P

## PARTS MANUAL



An Operators Manual with **IMPORTANT** Safety, Assembly, Operation and Maintenance information was packaged with this Parts Manual during final inspection at the factory. If the Operators Manual is missing at any time, please contact Tiger Corporation to receive your free replacement manual.

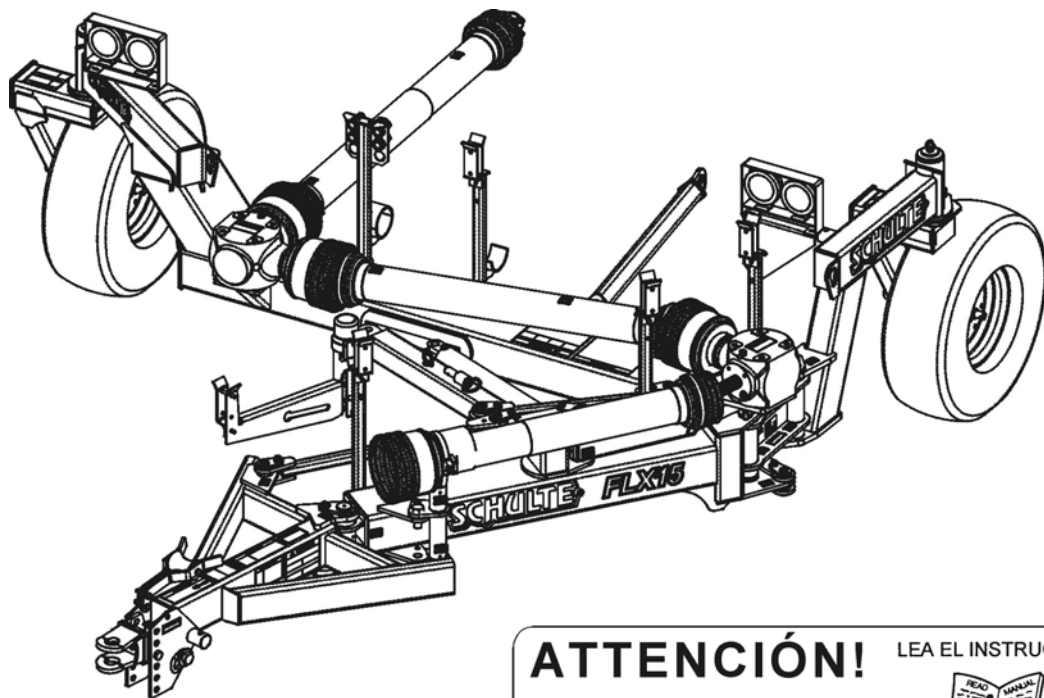

### ATENCIÓN!

LEA EL INSTRUCTIVO

Si No Lee Ingles, Pida Ayuda a Alguien  
Que Si Lo Lea Para Que le Traduzca las  
Medidas de Seguridad.



**Tiger Corporation**  
3301 N. Louise Ave.  
Sioux Falls, SD 57107  
1-800-843-6849  
1-605-336-7900  
[www.tiger-mowers.com](http://www.tiger-mowers.com)



## PARTS ORDERING GUIDE

The following instructions are offered to help eliminate delay and error in processing purchase orders for the equipment in this section.

1. The Purchase Order must include the name and address of the person or organization ordering the parts, who should be charged, and if possible, the serial number of the machine for which the parts were ordered.
2. The Purchase Order must clearly list the quantity of each part, the complete and correct part number, and the description of the part.
3. The Manufacturer reserves the right to substitute parts where applicable.
4. The Manufacturer reserves the right to change prices without prior notice.

**NOTE:** Please refer to the Safety Section in the front of the Operators Manual for the proper Part Number when ordering Replacement Safety Decals. Safety decals are available free of charge from the Manufacturer.

**NOTE:** If the Operators Manual does not accompany this Parts Manual please obtain one, free of charge from the Manufacturer. DO NOT operate this implement unless you READ, UNDERSTAND, and FOLLOW the Safety and Operation instructions contained in the Operators Manual

**NOTE:** Please note that the appearance of some parts may vary from the artwork shown in the Manual.



For maximum safety and to guarantee optimum product reliability, always use genuine OEM Parts. The use of inferior replacement parts may cause premature or catastrophic failure which could result in serious injury or death. Direct any questions regarding parts to:

**Tiger Corporation**  
3301 N. Louise Ave.  
Sioux Falls, SD 57107  
1-800-843-6849  
1-605-336-7900  
[www.tiger-mowers.com](http://www.tiger-mowers.com)



## TABLE OF CONTENTS

HITCH ASSEMBLY .....	6-4
PRECISION CLEVIS .....	6-5
PRECISION HITCH .....	6-6
BEARING MOUNT ASSEMBLY .....	6-7
ARM ASSEMBLY .....	6-8
FRAME ASSEMBLY .....	6-10
CASTOR FRAME ASSEMBLY .....	6-12
CASTOR WHEEL ASSEMBLY .....	6-13
HUB & TIRE ASSEMBLY .....	6-14
HITCH JACK, 10" SIDE WIND (232-500) .....	6-15
SAFETY TOW CHAIN (S000-010) .....	6-16
TRANSPORT LIGHT KIT .....	6-17
HYDRAULIC CIRCUIT .....	6-18
HYDRAULIC CYLINDER .....	6-20
HYDRAULIC SELECTOR VALVE, FLX15 (A101-350) .....	6-21
HYDRAULIC SELECTOR VALVE, FLX10 (A102-350) .....	6-22
HYDRAULIC SELECTOR VALVE, SWITCH & HARNESS .....	6-23
DRIVELINE REFERENCE .....	6-24
SFT SAFETY SHIELDS .....	6-24
DRIVE SHAFT, IMPLEMENT, 1-3/4 Z20 SIZE 8 (340-841) .....	6-25
CROSS SHAFT, FLX15, 1-3/4 Z20 SIZE 8 (340-842) .....	6-26
CROSS SHAFT, FLX10, 1-3/4 Z20 SIZE 8 (340-843) .....	6-27
JACK SHAFT,1-3/4 Z20 SIZE 8 (340-844) .....	6-28
GEARBOX,1:1, BP#S2100100083 (330-556) .....	6-29
PARTS INDEX .....	6-30

## HITCH ASSEMBLY

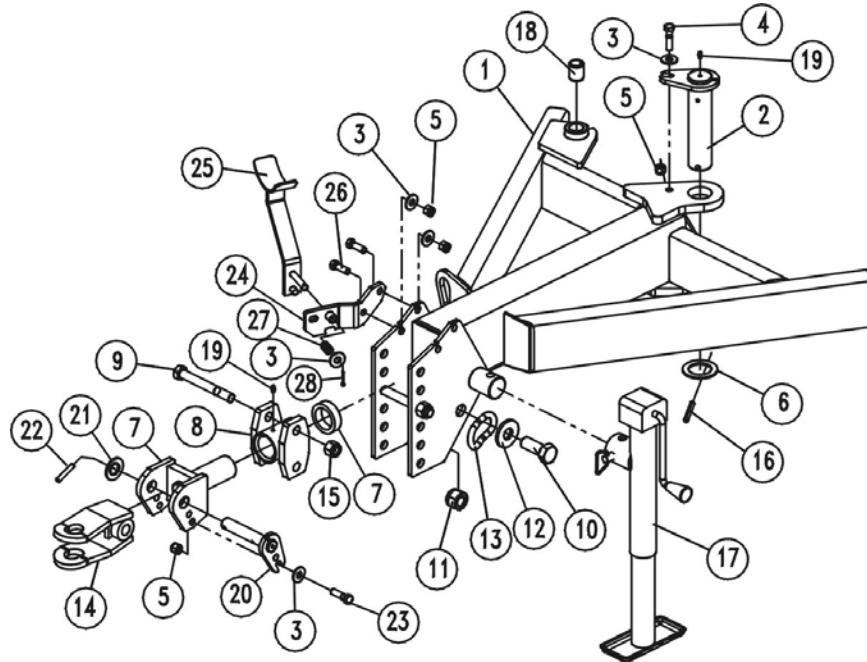

Ref.	Part No.	Description	Qty.
1	A101-110	Hitch frame	1
2	A101-145	Pin, hitch frame	1
3	256-011	Washer, 1/2"	4
4	250-057	Bolt, 1/2" x 2" UNC	1
5	270-007	Locknut, 1/2" UNC	4
6	256-0533	Machine bushing, 2" x 3" x 10ga	1
7	A101-171	Hitch Swivel - <i>*sold with 774-012</i>	1
	774-012	Weld sleeve - <i>*sold with A101-171</i>	1
8	A101-112	Sleeve sub-assembly	1
9	250-107	Bolt, 3/4" x 6" UNC	2
10	250-127	Bolt, 1" x 2-1/2" UNC	1
11	270-002	Locknut, 1" UNC	1
12	256-0011	Washer, 1" x 1/4" Thick	1
13	S000-010	Safety chain - <i>*attachment link shown only</i>	1
14	C502-107	Hitch Clevis	1
15	270-001	Locknut, 3/4" UNC	2
16	262-004	Roll pin, 3/8" x 3"	1
17	232-500	Hitch jack, 10" side wind	1
18	362-011	Tension bushing, 1" x 1-1/4" x 1-1/2"	1
19	273-006	Grease nipple, self tap	2
20	CS01-134	Pin, 1" x 4 5/8", 4 11/16" U.L.	1
21	256-001	Washer, 1" plated SAE	1
22	262-006	Roll Pin, 3/8" x 2" Plated	1
23	250-060	Bolt, 1/2" x 1-3/4" UNC Gr 5 Plated	1
24	A101-364	Mount, PTO Stand	1
25	C000-132	Stand, Power Shaft	1
26	250-059	Bolt, 1/2" x 1-3/4" UNC Gr 5 Plated	2
27	229-010	Compression Spring, 1/2" x 1.5" LG	1
28	271-008	Cotter Pin, 1/8" x 1 Plated	1

## PRECISION CLEVIS (C000-360)

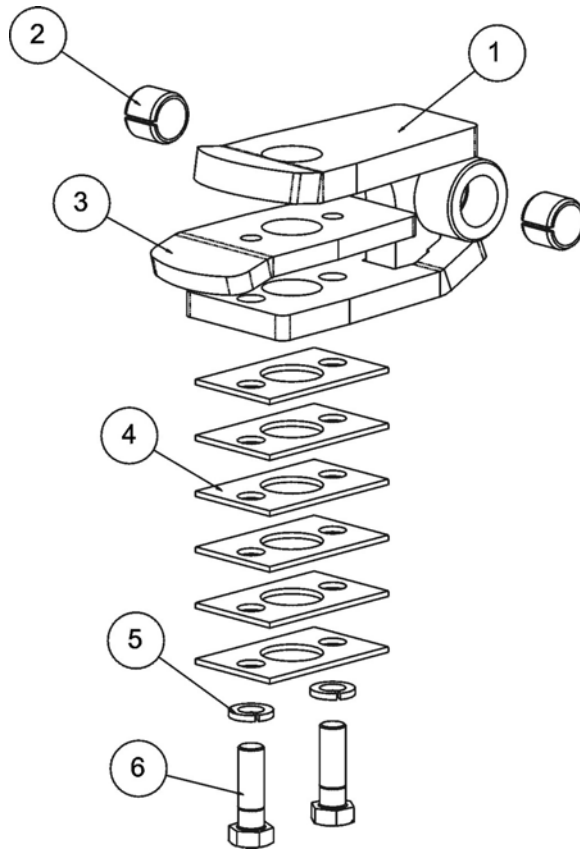

Ref.	Part No.	Description	Qty.
1	C000-360	Hitch block	1
2	362-015	Tension bushing, 1" x 1-1/4" x 1" lg	2
3	C000-363	Wear plate	1
4	C000-362	Spacer plate	6
5	255-005	Lockwasher, 5/8"	2
6	250-090	Bolt, 5/8" x 2" UNC	2

## PRECISION HITCH (C000-300)

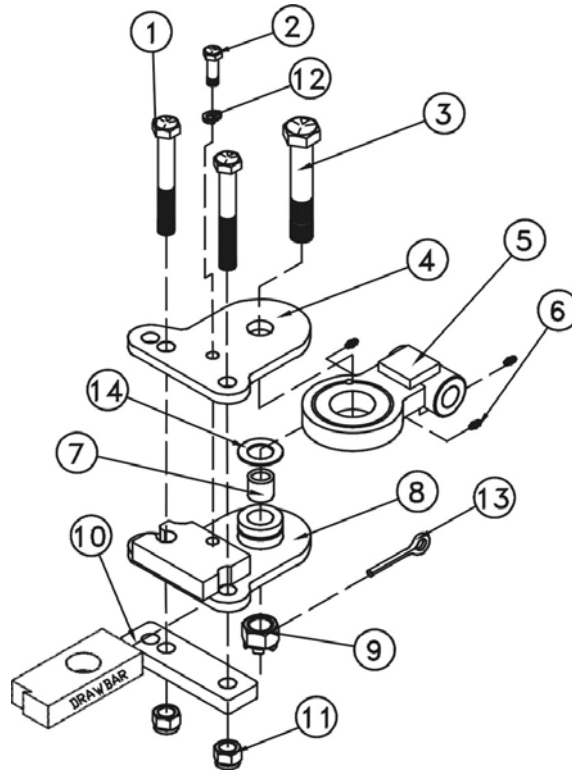

Ref.	Part No.	Description	Qty.
1	250-109	Bolt, 3/4 x 5-1/2 UNC	2
2	250-059	Bolt, 1/2 x 1-1/2 UNC	1
3	C000-202	Bolt, 1-1/8 x 5-1/2 UNF	1
4	C000-303	Drawbar clevis top	1
5	C000-301	Hitch tongue	1
6	273-001	Grease nipple, 1/8 NPT	3
7	C000-305	Spacer	1
8	C000-302	Draw bar clevis base	1
9	257-003	Lock nut, 1-1/8 UNF	1
10	C000-304	Clamp bar	1
11	270-001	Lock nut, 3/4 UNC	2
12	255-009	Lock washer, 1/2	1
13	271-011	Cotter pin, 1/4 x 2-1/2	1
14	256-0712	Machine Bushing Spacer (Only required if Hitch tongue is tight)	1

## BEARING MOUNT ASSEMBLY

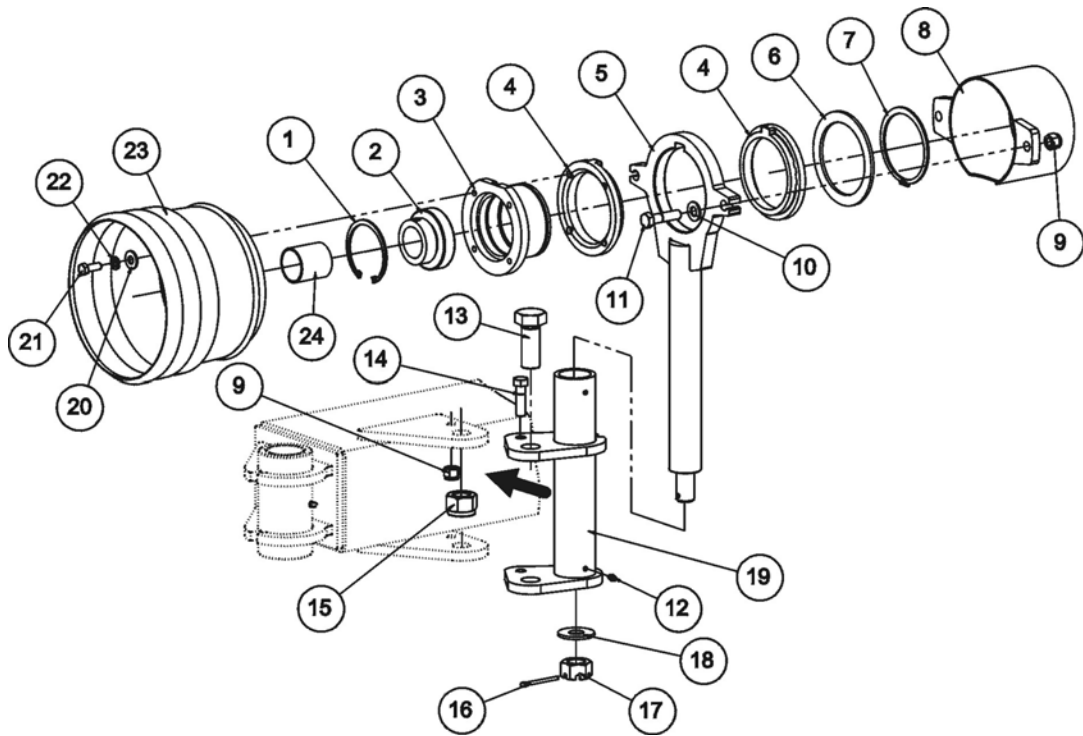

Ref.	Part No.	Description	Qty.
1	264-004	Retaining ring, internal	1
2	356-310	Locking Collar / Bearing set	1
3	A101-150	Bearing holder	1
4	A101-152	Rubber ring, vibration isolator	2
5	A101-153	Bearing stand	1
6	A101-155	Washer, 4-1/16" x 7 ga	1
7	264-014	Retaining ring, external	1
8	A101-154	Shield	1
9	270-007	Locknut, 1/2" UNC	4
10	256-011	Washer, 1/2"	2
11	250-057	Bolt, 1/2" x 2" UNC	2
12	273-006	Grease nipple, self tap	2
13	250-127	Bolt, 1" x 2-1/2" UNC	2
14	250-060	Bolt, 1/2" x 1-3/4" UNC	2
15	270-002	Locknut, 1" UNC	2
16	271-006	Cotter pin, 3/16" x 2"	1
17	257-009	Hex slotted nut, 1" UNC	1
18	256-001	Washer, 1" SAE type	1
19	A101-156	Bearing stand mount	1
20	256-017	Washer, 3/8"	4
21	250-018	Bolt, 3/8" x 1" UNC	4
22	255-013	Lockwasher, 3/8"	4
23	341-6241	SFT shield	1
24	A101-157	Spacer, 1.151" Long	1
	A101-158	Spacer, 0.871" Long	1

**NOTE: USE LONG SPACER (ITEM 24, 1.151" LONG) FIRST AND IF TOO LONG TO ALLOW THE TRACTOR SHAFT TO BOLT ON USE SHORT SPACER (0.871" LONG)**

# ARM ASSEMBLY

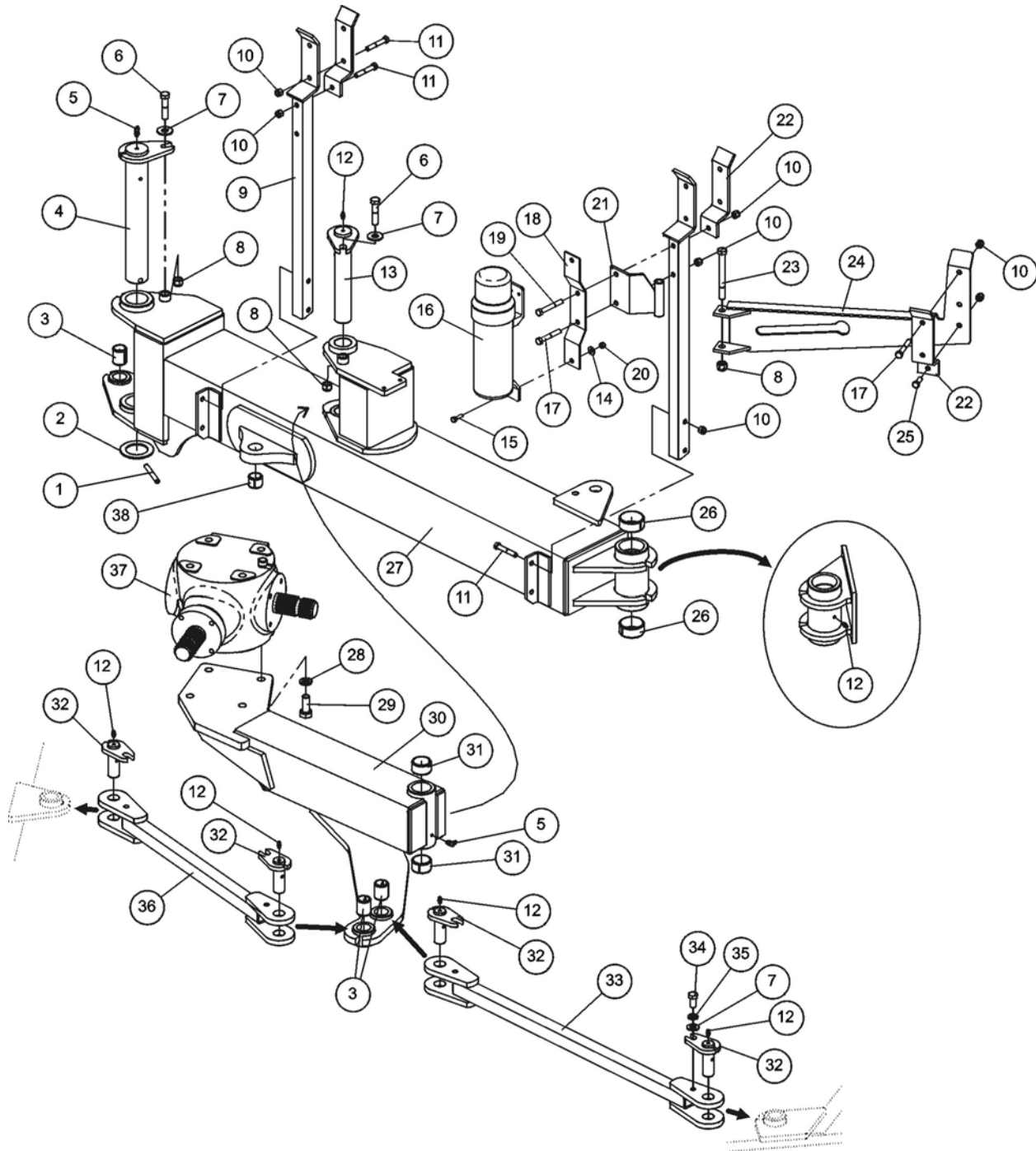



## ARM ASSEMBLY

Ref.	Part No.	Description	Qty.
1	262-004	Roll pin, 3/8" x 3"	1
2	256-3533	Machine bushing, 2" x 3" x 10ga	1
3	362-011	Tension bushing, 1" x 1-1/4" x 1-1/2" long	3
4	A101-141	Pin, arm assembly	1
5	273-011	Grease nipple, 90° self tap	2
6	250-0542	Bolt, 1/2" x 2-1/4" UNC	2
7	256-011	Washer, 1/2"	6
8	270-007	Locknut, 1/2" UNC	3
9	A101-136	Hydraulic hose stand	2
10	270-017	Locknut, 3/8" UNC	14
11	250-025	Bolt, 3/8" x 2-1/4" UNC	9
12	273-006	Grease nipple, self tap	6
13	A101-143	Pin, gearbox mount	1
14	256-018	Washer, 1/4"	2
15	250-002	Bolt, 1/4" x 1" UNC	2
16	280-201	Manual canister	1
17	250-026	Bolt, 3/8" x 2-1/2" UNC	1
18	A101-363	Manual canister mount	1
19	250-0261	Bolt, 3/8" x 2-3/4" UNC	1
20	270-025	Locknut, 1/4" UNC	2
21	A101-362	Hose arm mount	1
22	A101-139	Hose clamp	3
23	250-046	Bolt, 1/2" x 5" UNC	1
24	A101-361	Hose arm	1
25	250-018	Bolt, 3/8" x 1" UNC	1
26	362-019	Tension bushing, 2" x 2-1/4" x 1" long	2
27	A101-105	Arm	1
28	255-005	Lock washer, 5/8"	4
29	250-093	Bolt, 5/8" x 1-3/4" UNC	4
30	A101-108	Gearbox mounting arm	1
31	362-0121	Tension bushing, 1-1/2" x 1-3/4" x 1" long	2
32	A101-147	Pin, strut	4
33	A101-126	Strut, hitch	1
34	250-063	Bolt, 1/2" x 1" UNC	4
35	255-009	Lock washer, 1/2"	4
36	A101-127	Strut, frame	1
37	330-556	Gearbox	1
38	362-015	Tension bushing, 1" x 1-1/4" x 1" long	1

# FRAME ASSEMBLY

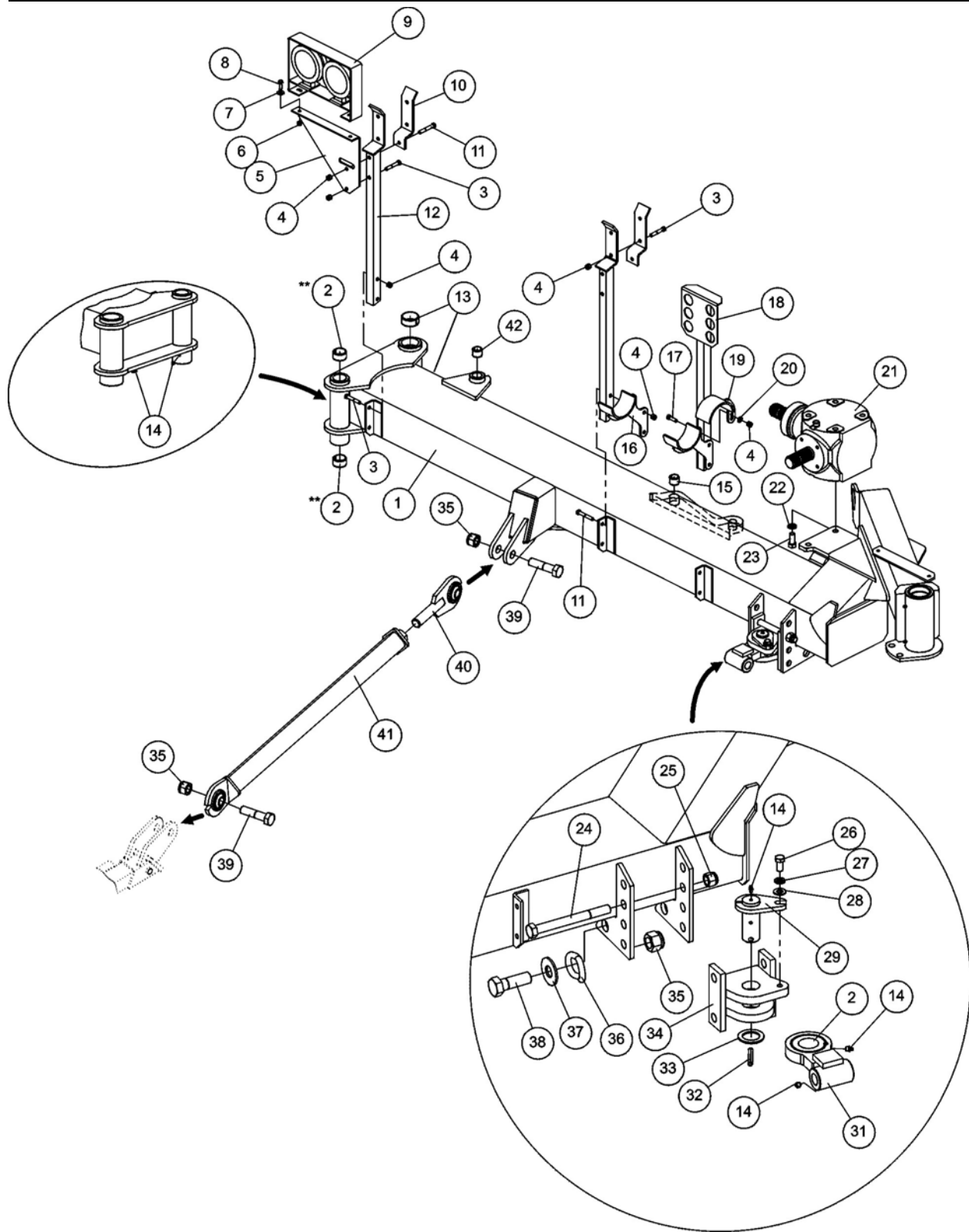

## FRAME ASSEMBLY

Ref.	Part No.	Description	Qty.
1	A101-101	FLX15 Main frame	1
	A102-101	FLX10 Main frame <i>*not shown</i>	1
2	362-0121	Tension bushing, 1-1/2" x 1-3/4" x 1" long <i>**not required on FLX10</i>	3
3	250-025	Bolt, 3/8" x 2-1/4" UNC	8
4	270-017	Locknut, 3/8" UNC	15
5	A101-137	Transport light mount	1
6	270-020	Locknut, 5/16" UNC	2
7	256-020	Washer, 5/16"	2
8	250-007	Bolt, 5/16" x 1" UNC	2
9	S000-073	Transport light kit <i>*left light shown only</i>	1
10	A101-139	Hose clamp	2
11	250-026	Bolt, 3/8" x 2-1/2" UNC	5
12	A101-136	Hydraulic hose stand	2
13	362-019	Tension bushing, 2" x 2-1/4" x 1" long	2
14	273-006	Grease nipple, self tap	5
15	362-015	Tension bushing, 1" x 1-1/4" x 1" long	1
16	A101-164	Driveline shipping/ storage bracket	2
17	250-019	Bolt, 3/8" x 1-1/4" UNC	2
18	A101-135	Hydraulic breakaway stand	1
19	A101-165	Driveline shipping/ storage clamp	2
20	256-017	Washer, 3/8"	2
21	330-556	Gearbox	1
22	255-005	Lock washer, 5/8"	4
23	250-095	Bolt, 5/8" x 1-1/2" UNC	4
24	250-105	Bolt, 3/4" x 7-1/2" UNC	2
25	270-001	Locknut, 3/4" UNC	2
26	250-063	Bolt, 1/2" x 1" UNC	1
27	255-009	Lock washer, 1/2"	1
28	256-011	Washer, 1/2"	1
29	A101-149	Pin, cutter hitch	1
31	A101-133	Hitch tongue, rotary cutter	1
32	262-005	Roll pin, 3/8" x 2-1/2"	1
33	256-0552	Machine bushing, 1-1/2" x 2-1/4" x 10ga.	1
34	A101-132	Hitch clevis, rotary cutter	1
35	270-002	Locknut, 1" UNC	3
36	S000-010	Safety chain - <i>*attachment link shown only</i>	1
37	256-002	Washer, 1" AS type	1
38	250-127	Bolt, 1" x 2-1/2" UNC	1
39	250-145	Bolt, 1" x 4" UNC	2
40	A101-130	Link adjustment rod	1
41	A101-131	Link adjustment body	1
42	362-011	Tension bushing, 1" x 1-1/4" x 1-1/2" long	1

## CASTOR FRAME ASSEMBLY (FLX15 ONLY)

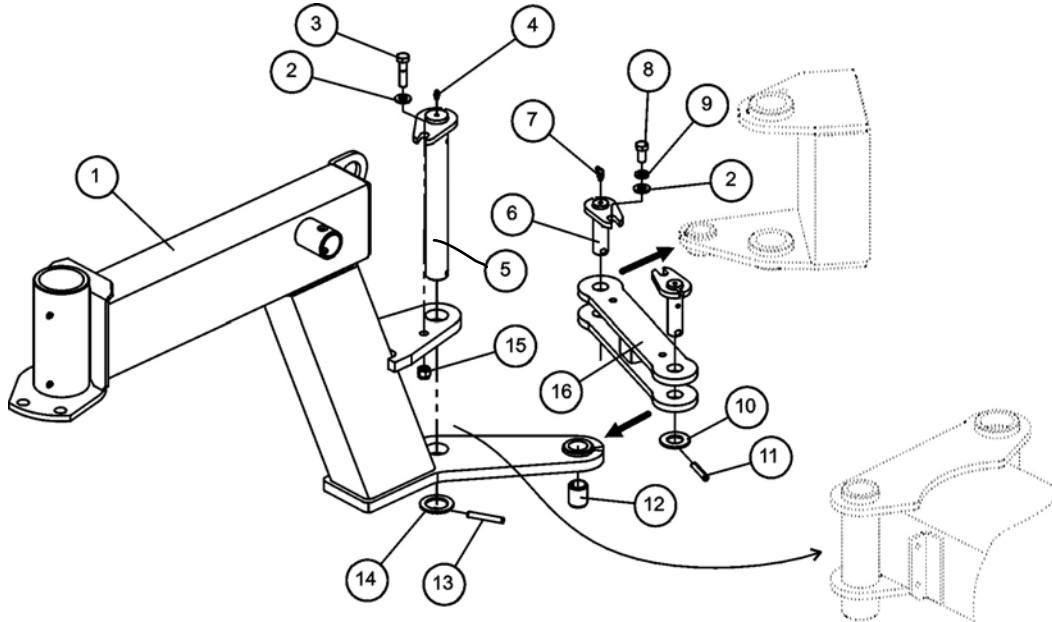

Ref.	Part No.	Description	Qty.
1	A101-104	Castor frame	1
2	256-011	Washer, 1/2"	3
3	250-057	Bolt, 1/2" x 2" UNC	1
4	273-006	Grease nipple, self tap	1
5	A101-144	Pin, castor frame	1
6	A101-146	Pin, castor link	2
7	273-011	Grease nipple, 90° self tap	2
8	250-063	Bolt, 1/2" x 1" UNC	2
9	255-009	Lock washer, 1/2"	2
10	256-001	Washer, 1" SAE type	2
11	262-006	Roll pin, 3/8" x 2"	2
12	362-011	Tension bushing, 1" x 1-1/4" x 1-1/2" long	1
13	262-005	Roll pin, 3/8" x 2-1/2"	1
14	256-0552	Machine bushing, 1-1/2" x 2-1/4" x 10ga.	1
15	270-007	Locknut, 1/2" UNC	1
16	A101-125	Castor link	1

## CASTOR WHEEL ASSEMBLY

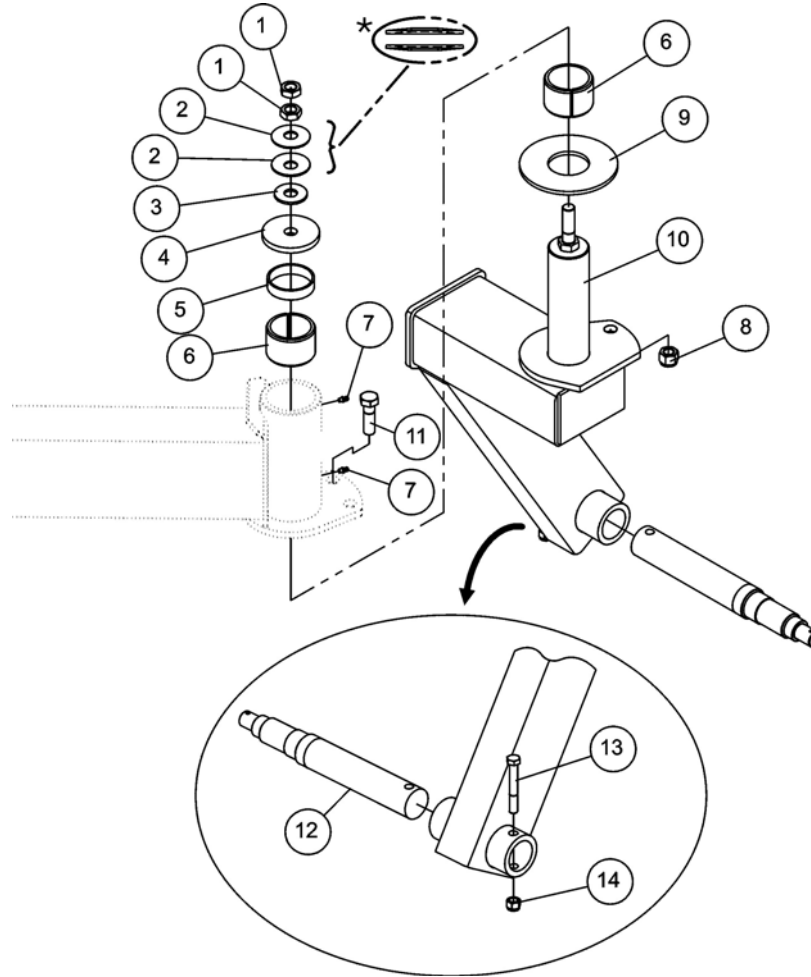

Ref.	Part No.	Description	Qty.
1	257-014	Jam nut, 3/4" UNF	2
2	256-510	Belville washer, 60 x 20.5 x 2.5mm	2
3	256-003	Washer, 3/4"	1
4	A101-122	Castor washer	1
5	A101-123	Castor spacer	1
6	364-001	Nylatron bushing, 2-1/2" x 3" x 2" long	2
7	273-006	Grease nipple, self tap	2
8	270-001	Locknut, 3/4" UNC	1
9	A101-124	Nylon castor disc	1
10	A101-120	Castor	1
11	250-114	Bolt, 3/4" x 2-1/2" UNC	1
12	208-026	Spindle, S618, 2" x 14-7/8"	1
13	250-050	Bolt, 1/2" x 3-1/2" UNC	1
14	270-007	Locknut, 1/2" UNC	1

\* Refer to the Assembly Section in the front of this Manual for Belville washer orientation

## HUB & TIRE ASSEMBLY

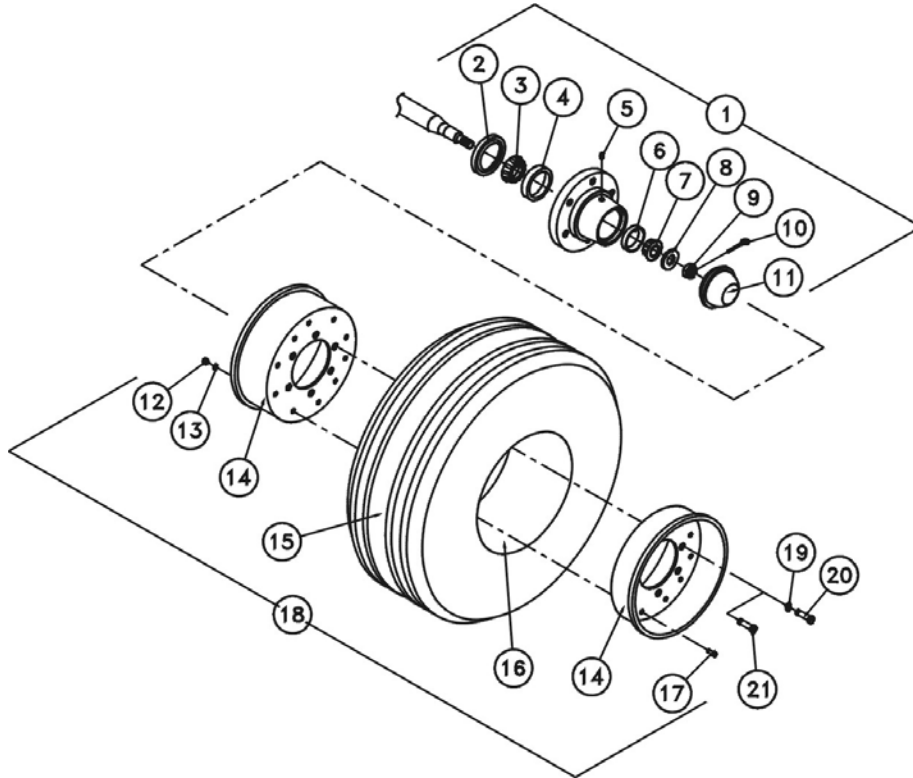

Ref.	Part No.	Description	Qty.
1	206-003	Hub, H618 complete, includes ref #2-11	1
2	207-018	Seal	1
3	207-013	Bearing	1
4	207-014	Race	1
5	273-002	Grease nipple, 45° 1/8" NPT	1
6	207-016	Race	1
7	207-015	Bearing	1
8	209-010	Washer, 1"	1
9	209-011	Castle nut, 1"-14 UNS	1
10	271-005	Cotter pin, 3/16"	1
11	207-017	Dust cap	1
12	257-032	Nut, 3/8" UNC	10
13	255-013	Lock washer, 3/8"	10
14	201-016	Rim half	2
15	210-011	Tire only	1
16	211-013	Tube	1
17	250-018	Bolt, 3/8" x 1" UNC	10
18	210-178	Aircraft tire, 31x 13 x 12 x 20 ply, complete includes ref #12-17	1
19	255-007	Lock Washer, 9/16"	6
20	250-073	Bolt, 9/16" x 1-1/2" UNF	6
21	207-011	Wheel Bolt, 9/16" x 1-3/4" UNF	6

NOTE: IF RIM HOLES ARE TAPERED USE WHEEL BOLT 207-011(# 21). IF RIM HOLES ARE FLAT USE BOLT 250-073 (# 20) AND LOCK WASHER 255-007 (# 19).

## HITCH JACK, 10" SIDE WIND (232-500)

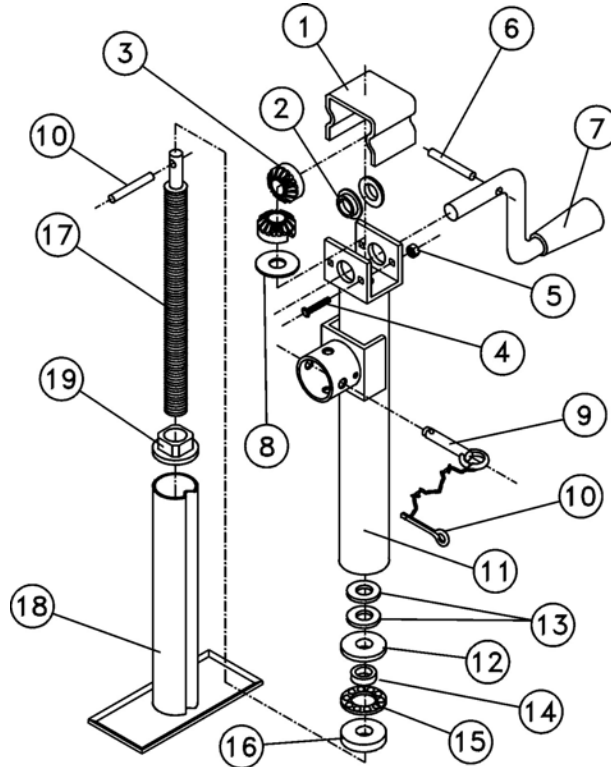

Ref.	Part No.	Description	Qty.
1	232-651	Gear cover	1
2	232-652	Bushing	2
3	232-653	Gear	2
4	232-654	Bolt, 1/4" x 3" UNC	2
5	232-655	Nut, 1/4" UNC	2
6	232-656	Pin, long	1
7	232-657	Handle	1
8	232-658	Washer, 1/2" x 1-1/2"	1
9	232-659	Lock pin & chain	1
10	232-660	Pin, long	1
11	232-661	Main body	1
12	232-662	Washer, 1/2" x 1-5/16" x 10ga	1
13	232-663	Washer, 1/2" x 1-1/16"	2
14	232-664	Felt bushing	1
15	232-665	Bearing	1
16	232-666	Washer, 1/2" x 1-1/16" x 7ga	1
17	232-667	Acme screw	1
18	232-668	Stand body	1
19	232-669	Acme nut	1

## SAFETY TOW CHAIN (S000-010)

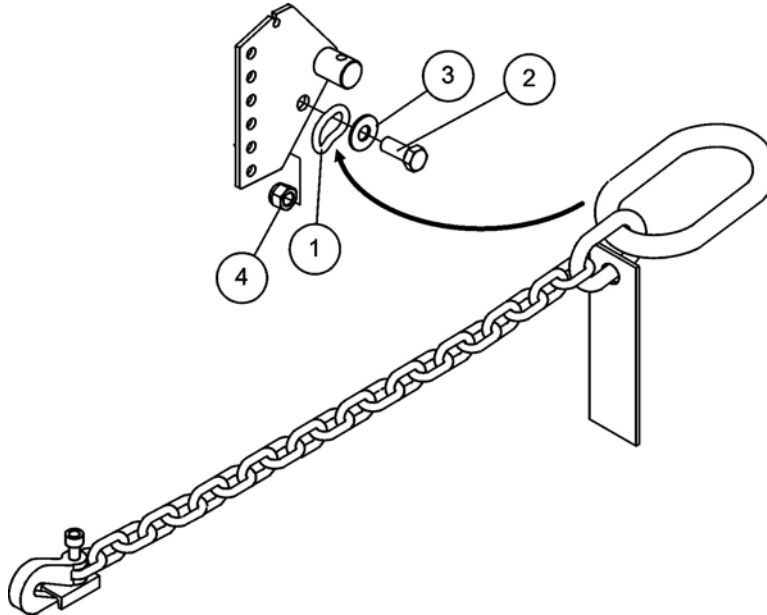

**NOTE:** This safety chain is intended as an auxiliary attaching system per ASAE S338.3. The safety chain help control the flex arm should it accidentally separate from the drawbar, or the rotary cutter should it accidentally separate from the flex arm. **Do not use the safety chain for towing.** Replace the entire chain if any link or end fitting is broken, damaged or stretched.

Ref.	Part No.	Description	Qty.
1	S000-010	Safety tow chain, 10,000 lbs capacity 59" minimum length	2
2	250-127	Bolt, 1" x 2-1/2" UNC	2
3	256-0011	Washer, 1" x 1/4" Thick	2
4	270-002	Locknut, 1" UNC	2



## TRANSPORT LIGHT KIT

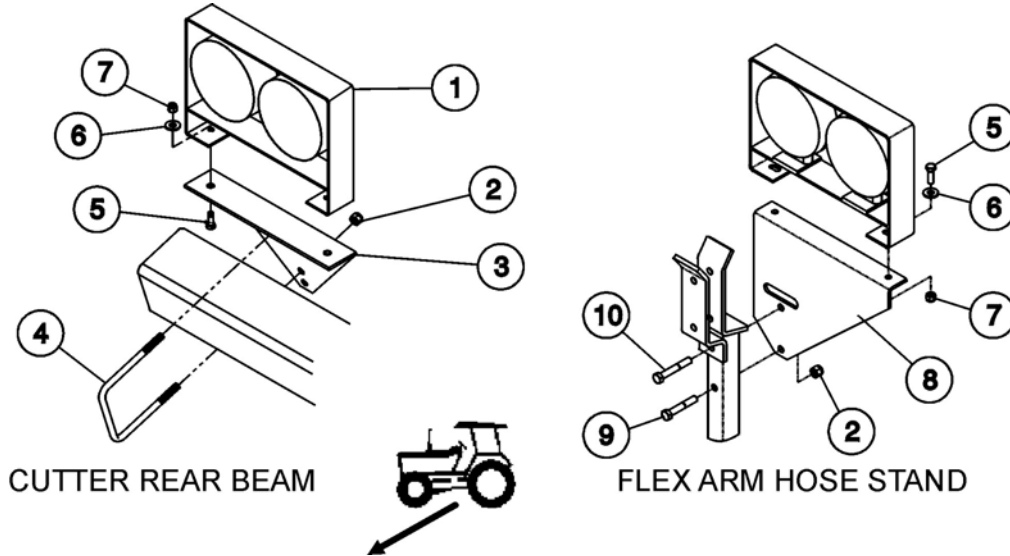

The lights are to be mounted with the red and amber facing to the rear, with the outside light being the amber.

Ref.	Part No.	Description	Qty.
1	S000-073	Light set, left and right dual lights <b>FLX15</b> Includes a 7 pin ag plug, & harness	1
	S000-072	Light set, left and right dual lights <b>FLX10</b> Includes a 7 pin ag plug, & harness	1
2	270-017	Locknut, 3/8" UNC	4
3	S000-046	Rear beam light mount	1
4	258-111	U-bolt, 5" x 6" x 3/8" UNC <b>XH1500/XH1000</b>	1
	258-1101	U-bolt, 4 x 4-3/4" x 3/8" UNC <b>S150/S100</b>	1
5	250-007	Bolt, 5/16" x 1" UNC	4
6	256-020	Washer, 5/16"	4
7	270-020	Locknut, 5/16" UNC	4
8	A101-137	Light mount	1
9	250-025	Bolt, 3/8" x 2-1/4" UNC	1
10	250-026	Bolt, 3/8" x 2-1/2" UNC	1

# HYDRAULIC CIRCUIT

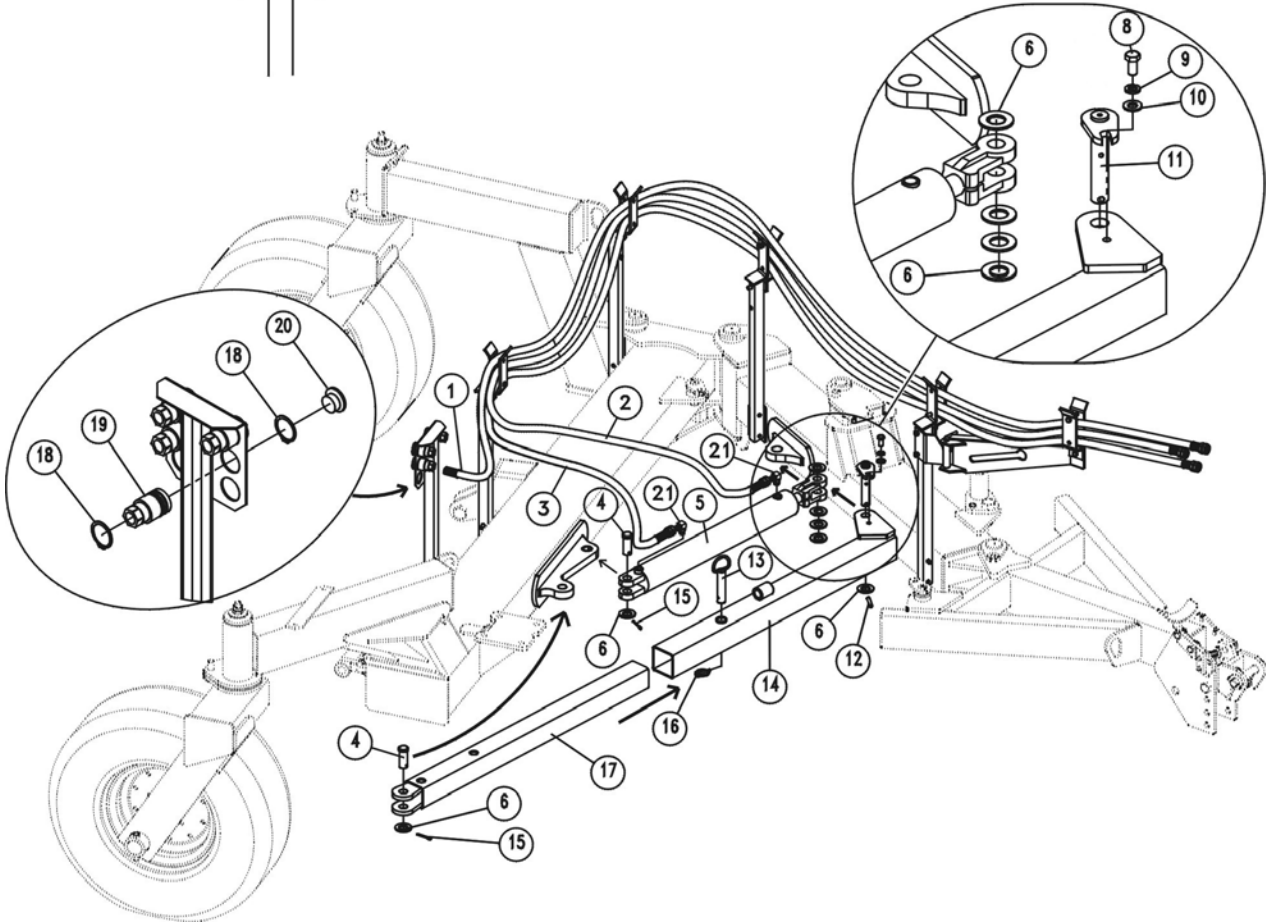
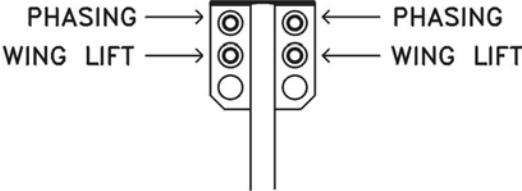

## HYDRAULIC CIRCUIT

Ref.	Part No.	Description	Qty.
1	111-260	Hydraulic hose, 230" M - M, <b>FLX15</b>	4
	111-257	Hydraulic hose, 200" M - M, <b>FLX10</b>	3
2	111-258	Hydraulic hose, 250" M - F, <b>FLX15</b>	1
	111-259	Hydraulic hose, 223" M - F, <b>FLX10</b>	1
3	111-261	Hydraulic hose, 230" M - F, <b>FLX15</b>	1
	111-195	Hydraulic hose, 203" M - F, <b>FLX10</b>	1
4	302-015	Clevis pin, 1" x 2-7/8" UL	2
5	100-3102	Hydraulic cylinder, 24" stroke, <b>FLX15</b>	1
	100-3077	Hydraulic cylinder, 20" stroke, <b>FLX10</b>	1
6	256-001	Washer, 1" SAE type	7
8	250-063	Bolt, 1/2" x 1" UNC	1
9	255-009	Lock washer, 1/2"	1
10	256-011	Washer, 1/2"	1
11	A101-148	Pin, cylinder guard	1
12	262-006	Roll pin, 3/8" x 2"	1
13	A101-140	Transport lock pin	1
14	A101-129	Cylinder guard outer, <b>FLX15</b>	1
	A102-129	Cylinder guard outer, <b>FLX10</b>	1
15	271-005	Cotter pin, 3/16" x 1-1/2"	2
16	300-012	Lynch pin, 1/4" standard	1
17	A101-128	Cylinder guard inner, <b>FLX15</b>	1
	A102-128	Cylinder guard inner, <b>FLX10</b>	1
18	264-013	Retaining ring	
		<b>FLX15</b>	8
		<b>FLX10</b>	6
19	108-064	Coupler, female	
		<b>FLX15</b>	4
		<b>FLX10</b>	3
20	108-065	Coupler plug	
		<b>FLX15</b>	4
		<b>FLX10</b>	3
21	108-043	Elbow, 90° M - M	2

## HYDRAULIC CYLINDER

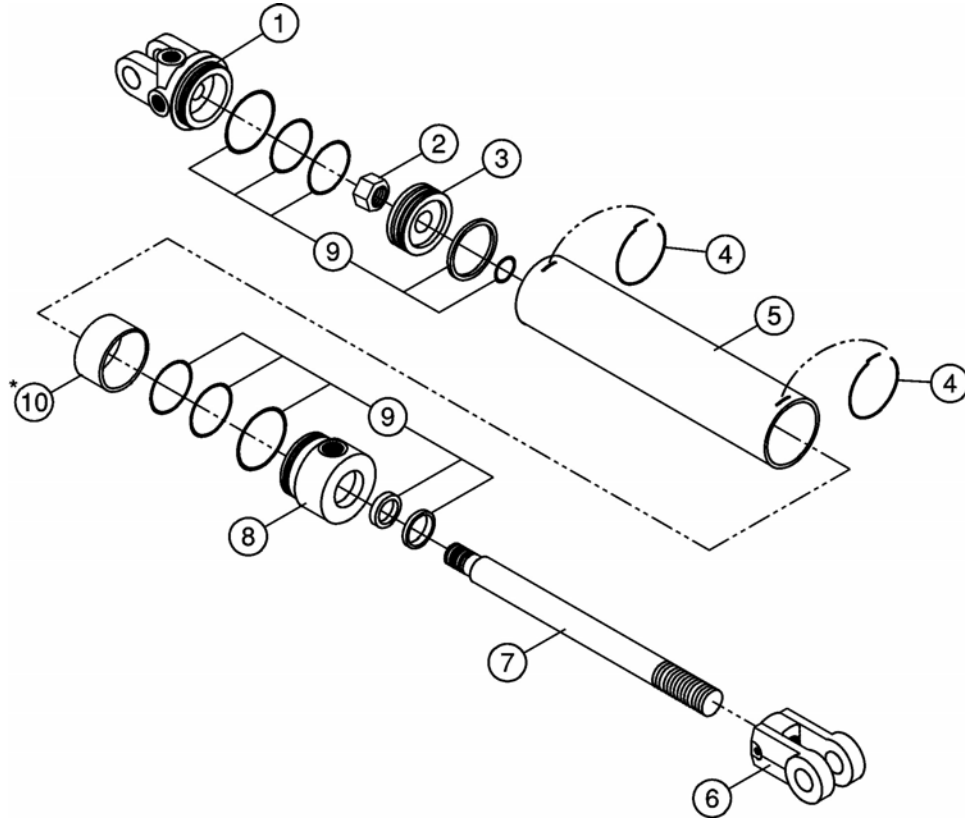

**100-3077 RAM-LOK, 3" bore x 20" stroke w/ 4" stop tube**  
**Location: FLX10**

**100-3102 RAM-LOK 3" bore x 24" stroke**  
**Location: FLX15**

Ref.	Part No.	Description	Qty.
1	102-280	Butt clevis	1
2	102-281	Piston nut	1
3	102-283	Piston	1
4	102-282	Retaining wire	2
5	102-285	Barrel, 24" <b>FLX15</b>	1
	102-290	Barrel, 20" <b>FLX10</b>	1
6	102-287	Rod clevis	1
7	102-284	Rod, 24" <b>FLX15</b>	1
	102-289	Rod, 20" <b>FLX10</b>	1
8	102-286	Cylinder head	1
9	102-288	Seal kit	1
10*	102-291	Stop tube <b>FLX10 only</b>	1

## HYDRAULIC SELECTOR VALVE, FLX15 (A101-350)

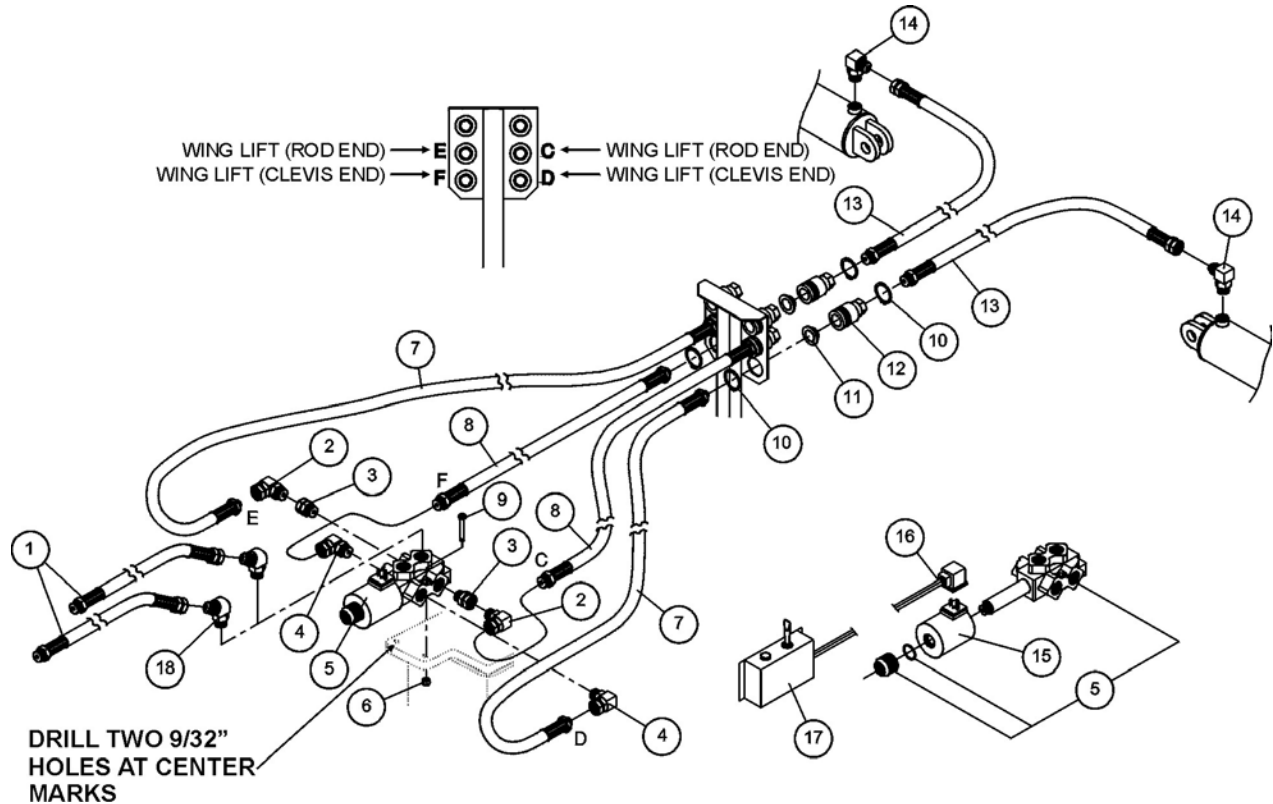

This optional kit reduces the required tractor ports and provides independent double acting wing lift action.

Ref.	Part No.	Description	Qty.
1	111-203	Hydraulic hose, 103" M - F	2
2	108-067	Elbow, 90° Male NPT - Female NPT	2
3	108-068	Extension Male ORB - Female NPT	2
4	108-066	Elbow, 90° Male ORB - Female NPT	2
5	127-015	Selector valve	1
6	270-025	Locknut, 1/4" UNC	2
7	111-260	Hydraulic hose, 230" M - M	2
8	111-260	<i>Supplied with Flex Arm</i>	2
9	250-003	Bolt, 1/4" x 2-1/2" UNC	2
10	264-013	Retaining ring	4
11	108-065	Coupler plug	2
12	108-064	Coupler, female	2
13	111-176	Hydraulic hose, 213" M - F	2
14	108-043	Elbow, 90° ORB	2
15	128-080	Replacement Solenoid	1
16	276-312	Harness assembly	1
17	276-300	Switch assembly	1
18	108-044	Elbow, 45° Male ORB - Male NPT	2

## HYDRAULIC SELECTOR VALVE, FLX10 (A102-350)

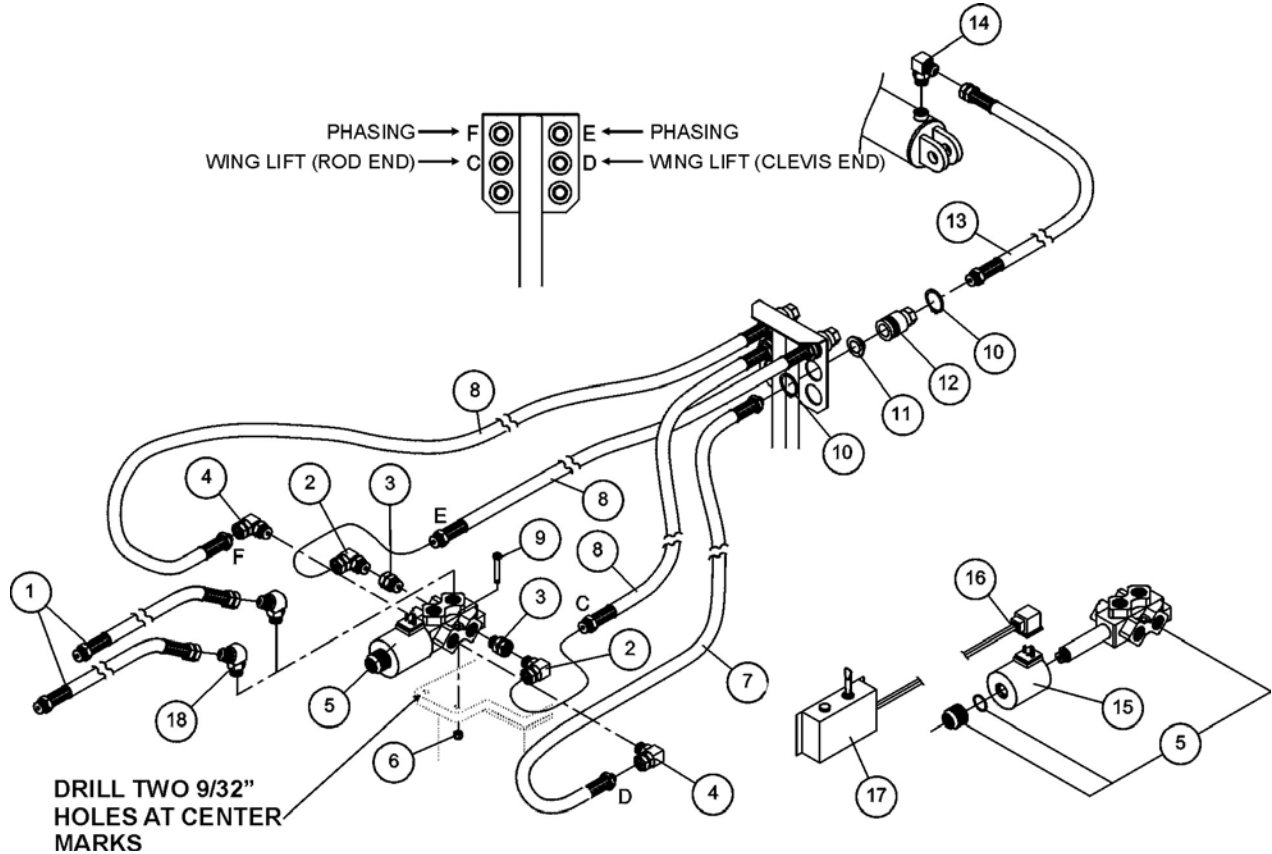

This optional kit reduces the required tractor ports and provides double acting wing lift action.

Ref.	Part No.	Description	Qty.
1	111-203	Hydraulic hose, 103" M - F	2
2	108-067	Elbow, 90° Male NPT - Female NPT	2
3	108-068	Extension Male ORB - Female NPT	2
4	108-066	Elbow, 90° Male ORB - Female NPT	2
5	127-015	Selector valve	1
6	270-025	Locknut, 1/4" UNC	2
7	111-257	Hydraulic hose, 200" M - M	1
8	111-257	<i>Supplied with Flex Arm</i>	3
9	250-003	Bolt, 1/4" x 2-1/2" UNC	2
10	264-013	Retaining ring	2
11	108-065	Coupler plug	1
12	108-064	Coupler, female	1
13	111-176	Hydraulic hose, 213" M - F	1
14	108-043	Elbow, 90° ORB	1
15	128-080	Replacement Solenoid	1
16	276-312	Harness assembly	1
17	276-300	Switch assembly	1
18	108-044	Elbow, 45° Male ORB - Male NPT	2

# HYDRAULIC SELECTOR VALVE, SWITCH & HARNESS

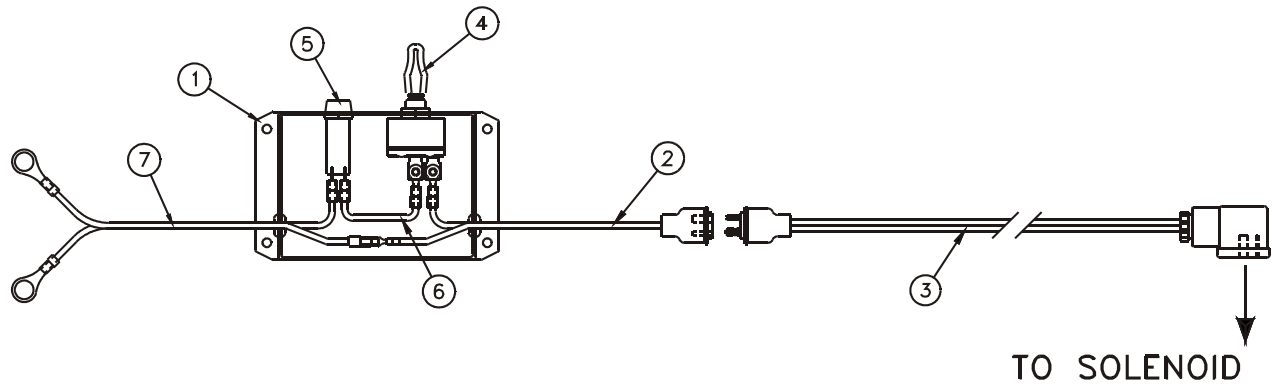

Ref.	Part No.	Description	Qty.
1	276-299	Switch box	1
2	276-298	Switch harness	1
3	276-312	Solenoid harness	1
4	275-001	Toggle switch, complete	1
5	275-010	Replacement fuse	1
6	276-297	Jumper cable	1
7	276-296	Power harness	1
8	276-300	Complete switch & harness, incl. 1,2,4,5,6,7	

## DRIVELINE REFERENCE

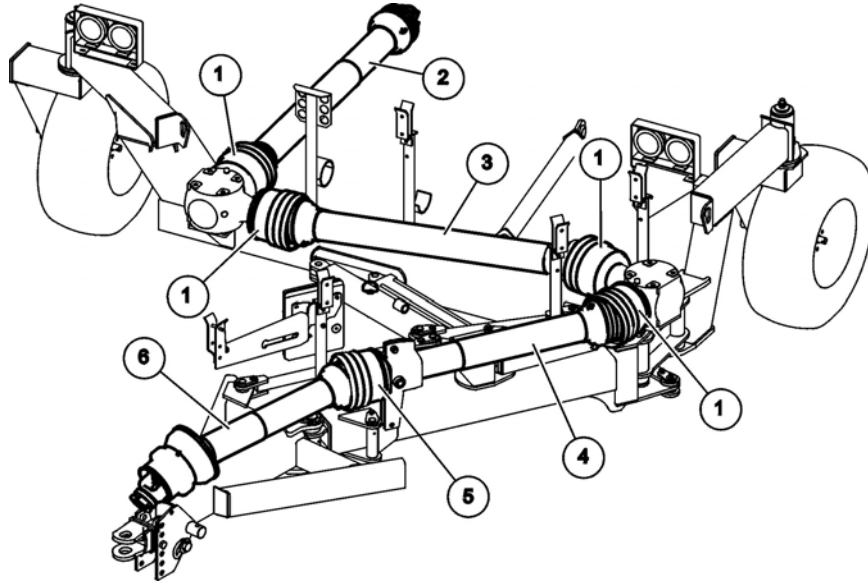

Ref.	Part No.	Description	Qty.
1	341-6238	SFT safety shield, $\varnothing$ 230mm	4
2	340-841	Drive shaft, implement	1
3	340-842	Cross shaft, <b>FLX15</b>	1
	340-843	Cross shaft, <b>FLX10</b>	1
4	340-844	Jack shaft	1
5	341-6241	SFT safety shield, $\varnothing$ 252mm	1
6	CV Assembly	- Supplied with Rotary Cutter	1

## SFT SAFETY SHIELDS

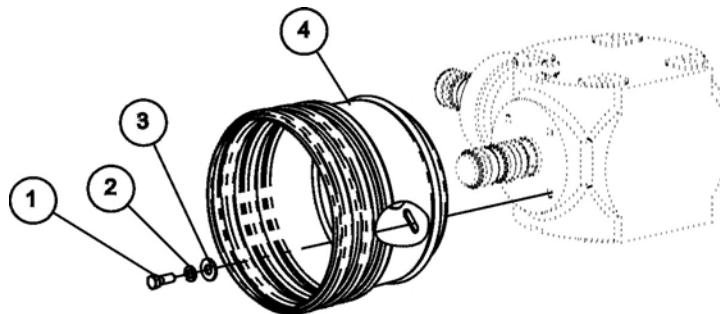

Ref.	Part No.	Description	Qty.
1	250-017	Bolt, 3/8" x 3/4" UNC	4
2	255-013	Lock washer, 3/8"	4
3	256-017	Washer, 3/8"	4
4	SFT safety shield	- See driveline reference	1



## DRIVE SHAFT, IMPLEMENT, 1-3/4 Z20 SIZE 8 (340-841)

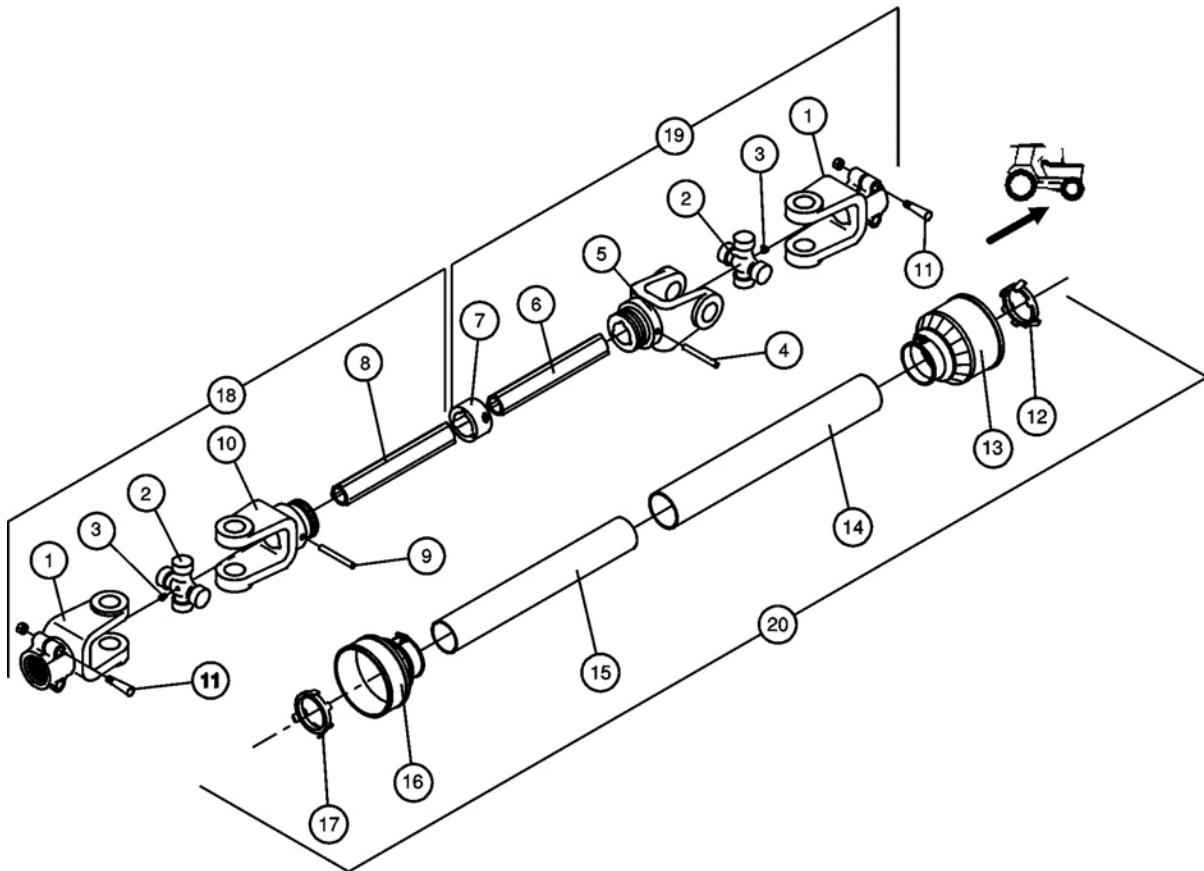

**340-841**    **Location: FLX15/ FLX10 Frame Gearbox to Cutter**

Ref.	Part No.	Description	Qty.
1	341-0863	Yoke	1
2	341-645	Cross journal c/w snap rings	2
3	341-603	Grease nipple, 45°	2
4	341-744	Flexible pin	1
5	341-769	Outer yoke	1
6	341-8143	Outer tube	1
7	341-0815	Ring nut	1
8	341-8142	Inner tube	1
9	341-8017	Flexible pin	1
10	341-0805	Inner yoke	1
11	341-802	Tapered pin kit	2
12	341-637	Shield bearing, outer shield	1
13	341-776	Outer cone set	1
14	341-8141	Outer shield	1
15	341-8140	Inner shield	1
16	341-8008	Inner cone set	1
17	341-642	Shield bearing, inner shield	1
18	341-8164	Inner half c/w shields	1
19	341-8163	Outer half c/w shields	1
20	341-8165	Complete shield set	1

## CROSS SHAFT, FLX15, 1-3/4 Z20 SIZE 8 (340-842)

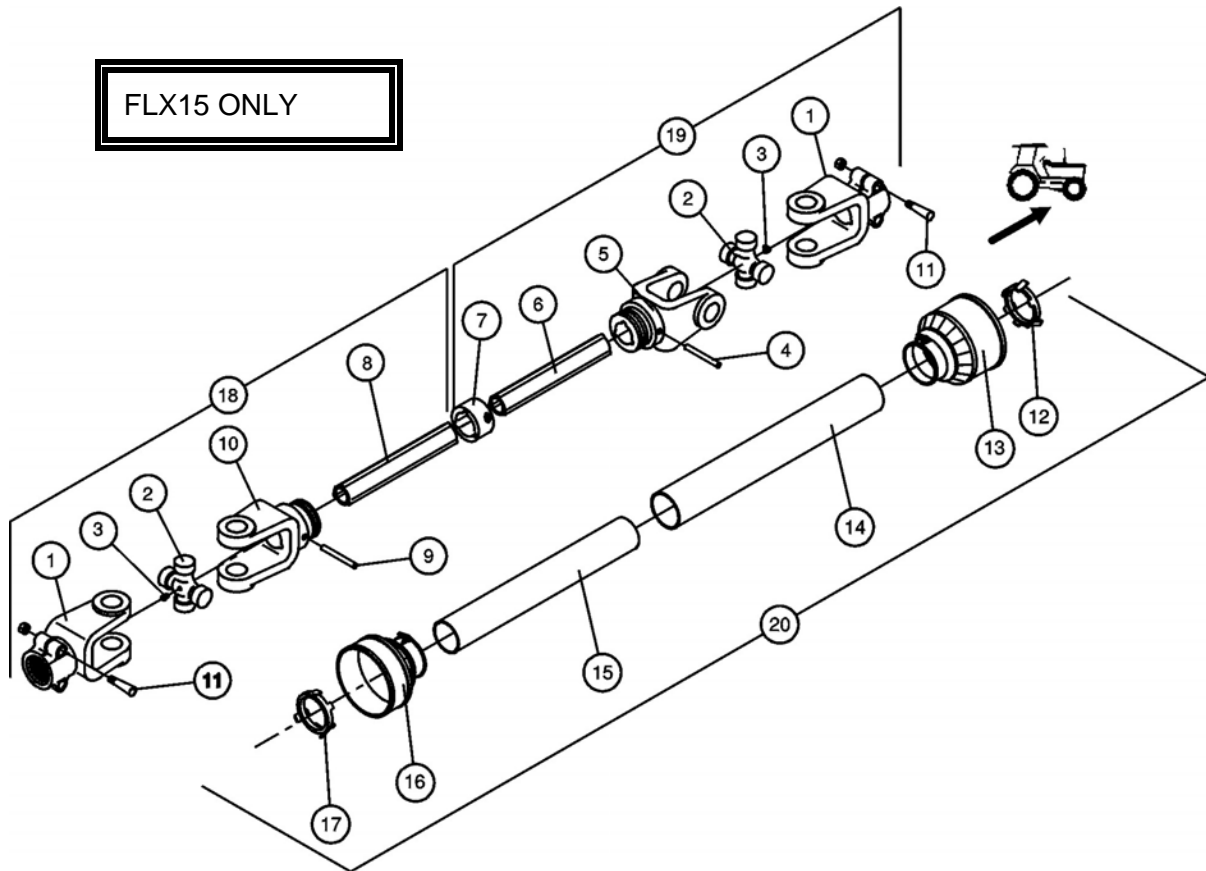

**340-842    Location: FLX15 Frame Gearbox to Arm Gearbox**

Ref.	Part No.	Description	Qty.
1	341-0863	Yoke	1
2	341-645	Cross journal c/w snap rings	2
3	341-603	Grease nipple, 45°	2
4	341-744	Flexible pin	1
5	341-769	Outer yoke	1
6	341-8147	Outer tube	1
7	341-0815	Ring nut	1
8	341-8146	Inner tube	1
9	341-8017	Flexible pin	1
10	341-0805	Inner yoke	1
11	341-802	Tapered pin kit	2
12	341-637	Shield bearing, outer shield	1
13	341-776	Outer cone set	1
14	341-8145	Outer shield	1
15	341-8144	Inner shield	1
16	341-8008	Inner cone set	1
17	341-642	Shield bearing, inner shield	1
18	341-8161	Inner half c/w shields	1
19	341-8160	Outer half c/w shields	1
20	341-8162	Complete shield set	1

## CROSS SHAFT, FLX10, 1-3/4 Z20 SIZE 8 (340-843)

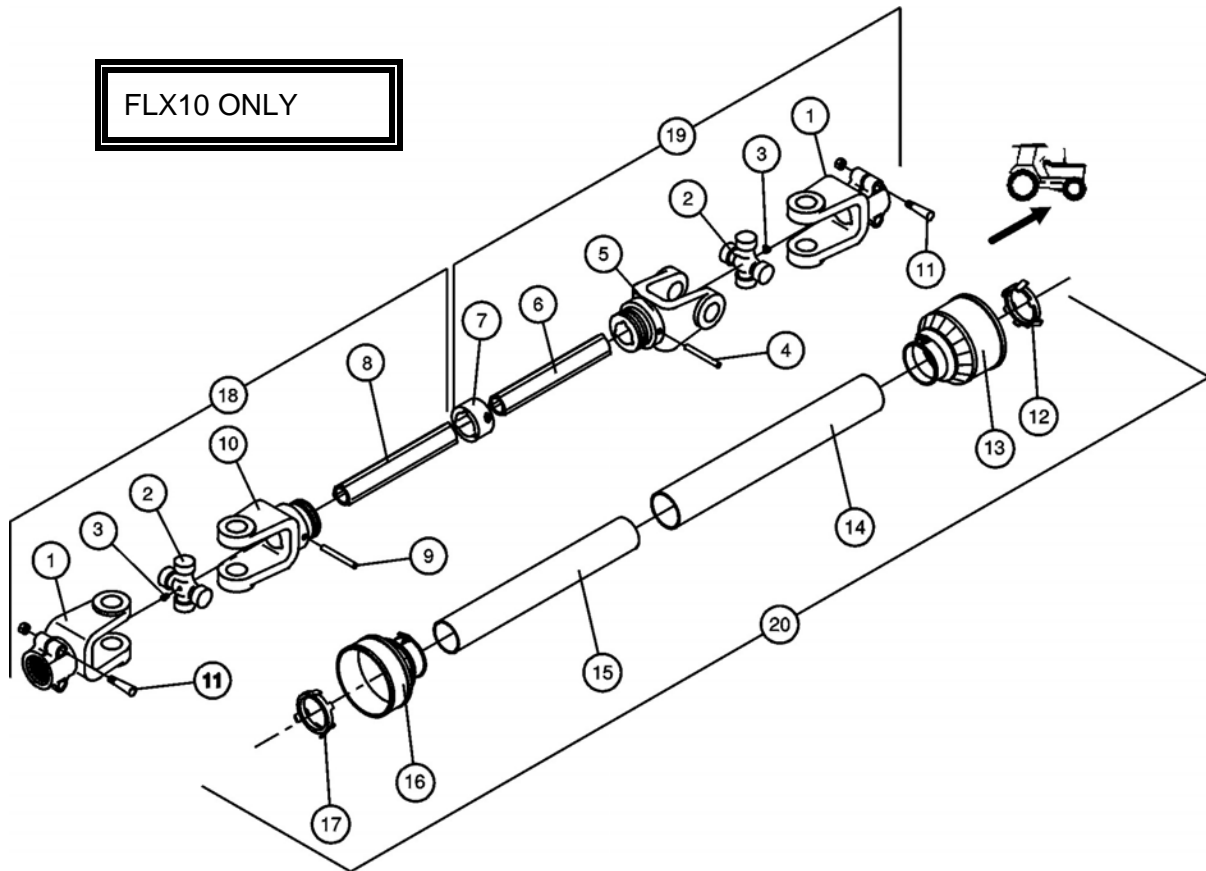

**340-843    Location: FLX10 Frame Gearbox to Arm Gearbox**

Ref.	Part No.	Description	Qty.
1	341-0863	Yoke	1
2	341-645	Cross journal c/w snap rings	2
3	341-603	Grease nipple, 45°	2
4	341-744	Flexible pin	1
5	341-769	Outer yoke	1
6	341-8151	Outer tube	1
7	341-0815	Ring nut	1
8	341-8150	Inner tube	1
9	341-8017	Flexible pin	1
10	341-0805	Inner yoke	1
11	341-802	Tapered pin kit	2
12	341-637	Shield bearing, outer shield	1
13	341-776	Outer cone set	1
14	341-8149	Outer shield	1
15	341-8148	Inner shield	1
16	341-8008	Inner cone set	1
17	341-642	Shield bearing, inner shield	1
18	341-8167	Inner half c/w shields	1
19	341-8166	Outer half c/w shields	1
20	341-8168	Complete shield set	1

## JACK SHAFT, 1-3/4 Z20 SIZE 8 (340-844)

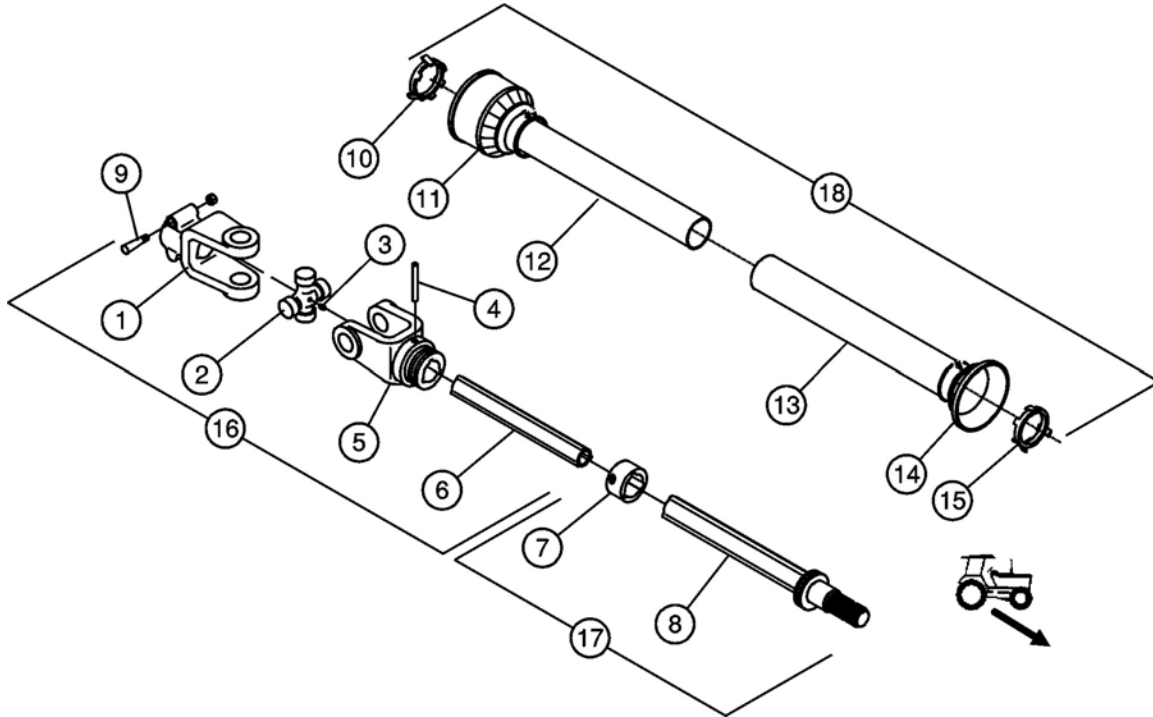

**340-844    Location: FLX15/ FLX10 Arm Gearbox to Bearing**

Ref.	Part No.	Description	Qty.
1	341-0863	Yoke	1
2	341-645	Cross journal c/w snap rings	1
3	341-603	Grease nipple, 45°	1
4	341-8017	Flexible pin	1
5	341-0805	Inner yoke	1
6	341-8155	Inner tube	1
7	341-0815	Ring nut	1
8	341-8154	Outer tube, 1-3/4 Z20	1
9	341-802	Tapered pin kit	1
10	341-642	Shield bearing, inner shield	1
11	341-8008	Inner cone set	1
12	341-8152	Inner shield	1
13	341-8153	Outer shield	1
14	341-8156	Outer cone set	1
15	341-637	Shield bearing, outer shield	1
16	341-8170	Inner half c/w shields	1
17	341-8169	Outer half c/w shields	1
18	341-8171	Complete shield set	1

## GEARBOX,1:1, BP#S2100100083 (330-556)

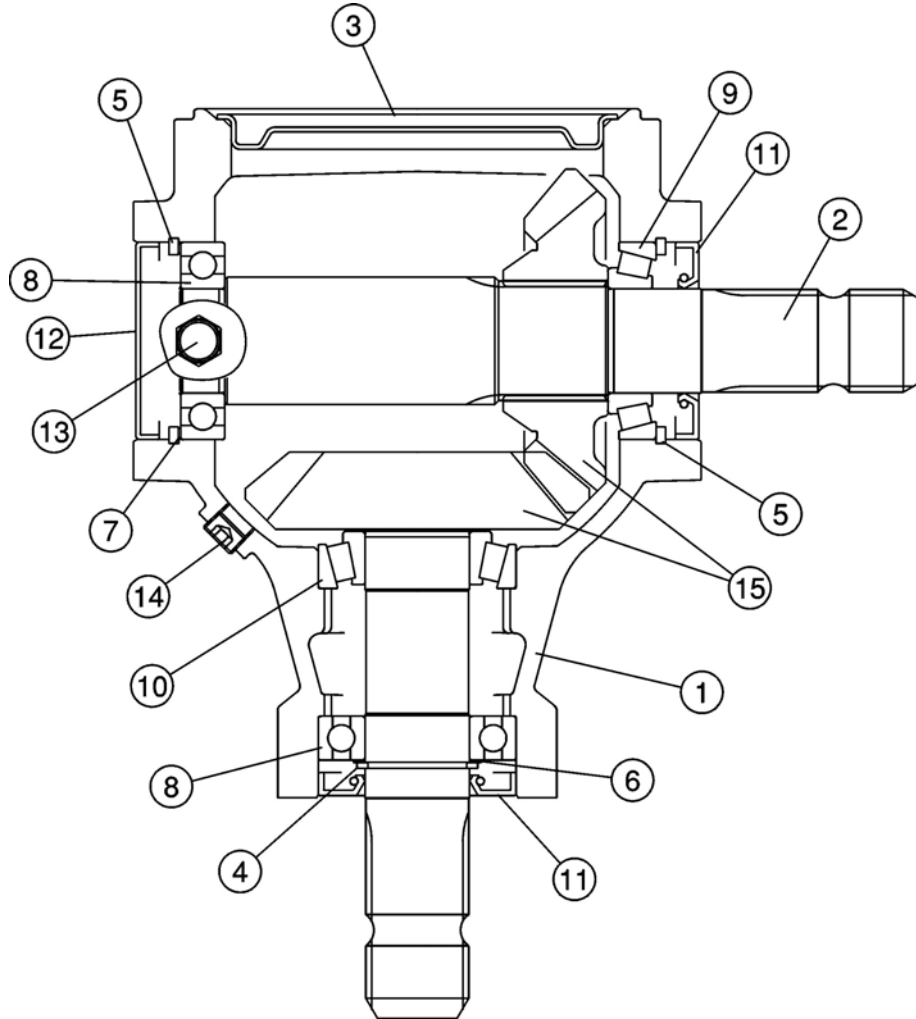

Ref.	Part No.	Description	Qty.
1	331-585	Housing	1
2	331-586	Shaft	1
3	331-581	Cover	1
4	331-562	Snap ring	1
5	331-552	Snap ring	2
6	331-587	Shim	A/R
7	331-588	Shim	A/R
8	331-9015	Ball bearing	2
9	331-564	Tapered roller bearing	1
10	331-575	Tapered roller bearing	1
11	331-589	Oil seal	2
12	331-559	Cap	1
13	331-590	Oil plug	1
14	331-561	Oil plug	2
15	331-591	Bevel gear set	1

## PARTS INDEX

Part Number	Page	Part Number	Page
100-3077	19, 20	232-657	15
100-3102	19, 20	232-658	15
102-280	20	232-659	15
102-281	20	232-660	15
102-282	20	232-661	15
102-283	20	232-662	15
102-284	20	232-663	15
102-285	20	232-664	15
102-286	20	232-665	15
102-287	20	232-666	15
102-288	20	232-667	15
102-289	20	232-668	15
102-290	20	232-669	15
102-291	20	250-002	9
108-043	19, 21, 22	250-003	21, 22
108-044	21, 22	250-007	11, 17
108-064	19, 21, 22	250-017	24
108-065	19, 21, 22	250-018	7, 9, 14
108-066	21, 22	250-019	11
108-067	21, 22	250-025	9, 11, 17
108-068	21, 22	250-026	9, 11, 17
111-185	21, 22	250-0261	9
111-195	19	250-046	9
111-203	21, 22	250-050	13
111-257	19, 22	250-0542	9
111-258	19	250-057	4, 7, 12
111-259	19	250-059	4, 6
111-260	19, 21	250-060	4, 7
111-261	19	250-063	9, 11, 12, 19
127-015	21, 22	250-074	14
128-080	21, 22	250-090	5
201-016	14	250-093	9
206-003	14	250-095	11
207-013	14	250-105	11
207-014	14	250-107	4
207-015	14	250-109	6
207-016	14	250-114	13
207-017	14	250-127	4, 7, 11, 16
207-018	14	250-145	11
208-026	13	255-005	5, 9, 11
209-010	14	255-007	14
209-011	14	255-009	6, 9, 11, 12, 19
210-011	14	255-013	7, 14, 24
210-178	14	256-001	4, 7, 12, 19
211-013	14	256-0011	4, 16
229-010	4	256-002	11
232-500	4, 15	256-003	13
232-651	15	256-011	4, 7, 9, 11, 12, 19
232-652	15	256-017	7, 11, 24
232-653	15	256-018	9
232-654	15	256-020	11, 17
232-655	15	256-0533	4
232-656	15	256-0552	11, 12

256-0712	6	340-843	24, 27
256-510	13	340-844	24, 28
257-003	6	341-0805	25-28
257-009	7	341-0815	25-28
257-014	13	341-0863	25-28
257-032	14	341-603	25-28
258-1101	17	341-6238	24
258-111	17	341-6241	7, 24
262-004	4, 9	341-637	25-28
262-005	11, 12	341-642	25-28
262-006	4, 12, 19	341-645	25-28
264-004	7	341-744	25-27
264-013	19, 21, 22	341-769	25-27
264-014	7	341-776	25-27
270-001	4, 6, 11, 13	341-8008	25-28
270-002	4, 7, 11, 16	341-8017	25-28
270-007	4, 7, 9, 12, 13	341-802	25-28
270-017	9, 11, 17	341-8140	25
270-020	11, 17	341-8141	25
270-025	9, 21, 22	341-8142	25
271-005	14, 19	341-8143	25
271-006	7	341-8144	26
271-008	4	341-8145	26
271-011	6	341-8146	26
273-001	6	341-8147	26
273-002	14	341-8148	27
273-006	4, 7, 9, 11-13	341-8149	27
273-011	9, 12, 19	341-8150	27
275-001	23	341-8151	27
275-010	23	341-8152	28
276-296	23	341-8153	28
276-297	23	341-8154	28
276-298	23	341-8155	28
276-299	23	341-8156	28
276-300	21-23	341-8160	26
276-312	21-23	341-8161	26
280-201	9	341-8162	26
300-012	19	341-8163	25
302-015	19	341-8164	25
330-556	9, 11, 29	341-8165	25
331-552	29	341-8166	27
331-559	29	341-8167	27
331-561	29	341-8168	27
331-562	29	341-8169	28
331-564	29	341-8170	28
331-575	29	341-8171	28
331-581	29	356-310	7
331-585	29	362-011	4, 9, 11, 12
331-586	29	362-0121	9, 11
331-587	29	362-015	5, 9, 11
331-588	29	362-019	9, 11
331-589	29	364-001	13
331-590	29	774-012	4
331-591	29	A101-101	11
331-9015	29	A101-104	12
340-841	24, 25	A101-105	9
340-842	24, 26	A101-108	9

A101-110	4
A101-112	4
A101-120	13
A101-122	13
A101-123	13
A101-124	13
A101-125	12
A101-126	9
A101-127	9
A101-128	19
A101-129	19
A101-130	11
A101-131	11
A101-132	11
A101-133	11
A101-135	11
A101-136	9, 11
A101-137	11, 17
A101-139	9, 11
A101-140	19
A101-141	9
A101-143	9
A101-144	12
A101-145	4
A101-146	12
A101-147	9
A101-148	19
A101-149	11
A101-150	7
A101-152	7
A101-153	7
A101-154	7
A101-155	7
A101-156	7
A101-157	7
A101-164	11
A101-165	11
A101-171	4
A101-350	21
A101-361	9
A101-362	9
A101-363	9
A101-364	4
A102-101	11
A102-128	19
A102-129	19
A102-350	22
C000-132	4
C000-202	6
C000-300	6
C000-301	6
C000-302	6
C000-303	6
C000-304	6
C000-305	6
C000-360	5
C000-362	5

C000-363	5
C502-107	4
CS01-134	4
PARTS	1, 2, 30
S000-010	4, 11, 16
S000-046	17
S000-072	17
S000-073	11, 17
SERIAL	2



