



# CHEETAH BOOM ASSEMBLIES

JD 5101E, 5093E & 5083E  
UP THROUGH SERIAL #'s

LV5101E260403

LV5093E260318

LV5083E260784

Current as of 08/18/2010



**PARTS LISTING WITH  
MOUNTING AND OPERATING  
INSTRUCTIONS**

**Tiger Corporation**  
3301 N. Louise Ave.  
Sioux Falls, SD 57107  
1-800-843-6849  
1-605-336-7900  
[www.tiger-mowers.com](http://www.tiger-mowers.com)

**06010005**

# TO THE OWNER / OPERATOR / DEALER

All implements with moving parts are potentially hazardous. There is no substitute for a cautious, safe-minded operator who recognizes the potential hazards and follows reasonable safety practices. The manufacturer has designed this implement to be used with all its safety equipment properly attached to minimize the chance of accidents.

**BEFORE YOU START!!** Read the safety messages on the implement and shown in this manual. Observe the rules of safety and use common sense!

**READ AND UNDERSTAND THIS MANUAL! Non-English speaking operators will need to GET THE MANUAL TRANSLATED as needed!**



# DANGER

**FAILING TO FOLLOW SAFETY MESSAGES AND OPERATING INSTRUCTIONS CAN CAUSE SERIOUS BODILY INJURY OR EVEN DEATH TO OPERATOR AND OTHERS IN THE AREA.**



1. Study and understand Operator's Manuals, Safety Decals, and Instructional Decals for tractor and implement to prevent misuse, abuse, and accidents. Practice before operating in a confined area or near passersby.

● Learn how to stop engine suddenly in an emergency. Be alert for passersby and especially children

2. Allow no children on or near folding mower or tractor. Allow no riders on tractor or implement. Falling off may cause serious injury or death from being run over by tractor or mower or contact with rotating blades.

3. Operate only with tractor having Roll-Over Protective Structure (ROPS) and with seat belt securely fastened to prevent injury and possible death from falling off or tractor overturn.

● Personal Protective Equipment such as Hard Hat, Safety Glasses, Safety Shoes, & Ear Plugs are recommended.

4. Block up or support raised machine and all lifted components securely before putting hands or feet under or working underneath any lifted component to prevent crushing injury or death from sudden dropping or inadvertent operation of controls. Make certain area is clear before lowering or folding

5. Before transporting, put Lift Lever in detent or full-lift position. Install Transport Safety Devices securely on folding mowers. Put Booms securely in Transport Rest.

● Folding and Boom Mowers have raised center of gravity. Slow down when turning and on hillsides.

6. Make certain that SMV sign, warning lights, and reflectors are clearly visible. Follow local traffic codes.

7. Never operate with Cutting Head or Folding Section raised if passersby, bystanders, or traffic are in the area to reduce possibility of injury or death from objects thrown by Blades under Guards or mower structure.

8. Before dismounting, secure implement in transport position or lower to ground.

● Put tractor in park or set brake, disengage PTO, stop engine, remove key, and wait until noise of rotation has ceased to prevent crushing by entanglement in rotating parts which could cause injury or death.

● Never mount or dismount a moving vehicle. Crushing from rollover may cause serious injury or death.



02967827

Warranty Information: Read and understand the complete Warranty Statement found in this manual. Fill out the Warranty Registration form in full and return it within 90 days. Make certain the Serial Number of the machine is recorded on the Warranty Card, and form that you retain.

# FORWARD

This manual contains information about many features of the Tiger mowing and roadside maintenance equipment. Some of these include: Safety precautions, Assembly instructions, Operations, Maintenance and Parts. This manual will also assist you in the proper break-in, daily care, and troubleshooting of your new mower.

We recommend that you read carefully the entire manual before operating the unit. Also, time spent in becoming fully acquainted with its performance features, adjustments, and maintenance schedules will be repaid in a long and satisfactory life of the equipment.

## **Troubleshooting - Please, before you call, help us to help you!**

Please look at the equipment to observe what is happening, then:

- Classify the problem
  - Hydraulic, electrical or mechanical - Read the trouble shooting section
  - Tractor or Truck chassis - Contact vehicle dealer
  
- If unable to correct the problem yourself, contact your local Tiger Dealer after gathering:
  - Machine model \_\_\_\_\_
  - Serial number \_\_\_\_\_
  - Dealer name \_\_\_\_\_
  - Detailed information about the problem including results of troubleshooting

**Attention Owner / Operator / Dealer:** It is your obligation to read, and understand, the warranty information section located at the back of this manual denoting that the purchaser understands the safety issues relating to this machine and has received and will read a copy of this manual.

If at any time, you have a service problem with your Tiger mower, Contact your local dealer for service and parts needed.

MANUFACTURED BY:

**Tiger Corporation**

3301 N. Louise Ave.

Sioux Falls, SD 57107

1-800-843-6849

1-605-336-7900

www.tiger-mowers.com

DISTRIBUTED BY:

\_\_\_\_\_

1- \_\_\_\_\_ - \_\_\_\_\_ - \_\_\_\_\_

1- \_\_\_\_\_ - \_\_\_\_\_ - \_\_\_\_\_



# TABLE OF CONTENTS

<b>SAFETY</b> _____	1-1
Safety Information_____	1-2
<b>ASSEMBLY / MOUNTING SECTION</b> _____	2-1
<b>OPERATION SECTION</b> _____	3-1
<b>MAINTENANCE SECTION</b> _____	4-1
<b>PARTS SECTION</b> _____	5-1
Parts Ordering Guide_____	5-2
Parts Table of Contents_____	5-3
<b>WARRANTY INFORMATION</b> _____	7-1



1012

**This symbol means:**

## **CAUTION – YOUR SAFETY IS AT RISK!**

When you see this symbol, read and follow the associated instructions carefully or personal injury or damage may result.

Tiger is a registered trademark.





# SAFETY

# SAFETY SECTION



# SAFETY

## General Safety Instructions and Practices

A safe and careful operator is the best operator. Safety is of primary importance to the manufacturer and should be to the owner / operator. Most accidents can be avoided by being aware of your equipment, your surroundings, and observing certain precautions. The first section of this manual includes a list of Safety Messages that, if followed, will help protect the operator and bystanders from injury or death. Read and understand these Safety Messages before assembling, operating or servicing this mower. This equipment should only be operated by those persons who have read the Manual, who are responsible and trained, and who know how to do so safely and responsibly.



1000

The Safety Alert Symbol combined with a Signal Word, as seen below, is used throughout this manual and on decals which are attached to the equipment. The Safety Alert Symbol means: “**ATTENTION! BECOME ALERT! YOUR SAFETY IS INVOLVED!**” The symbol and signal word are intended to warn the owner / operator of impending hazards and the degree of possible injury when operating this equipment.

**Practice all usual and customary safe working precautions and above all -- remember safety is up to YOU! Only YOU can prevent serious injury or death from unsafe practices.**

DANGER!



Indicates an imminently hazardous situation that, if not avoided, WILL result in DEATH OR VERY SERIOUS INJURY.

WARNING!



Indicates an imminently hazardous situation that, if not avoided, COULD result in DEATH OR SERIOUS INJURY.

CAUTION!



Indicates an imminently hazardous situation that, if not avoided, MAY result in MINOR INJURY.

**IMPORTANT!**

Identifies special instructions or procedures that, if not strictly observed, could result in damage to, or destruction of the machine, attachments or the environment.

**NOTE:** *Identifies points of particular interest for more efficient or convenient operation or repair.* (SG-1)

READ, UNDERSTAND, and FOLLOW the following Safety Messages. Serious injury or death may occur unless care is taken to follow the warnings and instructions stated in the Safety Messages. Always use good common sense to avoid hazards. (SG-2)

**SAFETY INSTRUCTIONS**





# SAFETY

**PELIGRO!**



Si no lee Ingles, pida ayuda a alguien que si lo lea para que le traduzca las medidas de seguridad. (SG-3)



**¡ LEA EL INSTRUCTIVO!**

**DANGER!**



Never operate the Tractor or Implement until you have read and completely understand this Manual, the Tractor Operator's Manual, and each of the Safety Messages found in the Manual or on the Tractor and Implement. Learn how to stop the tractor engine suddenly in an emergency. Never allow inexperienced or untrained personnel to operate the Tractor and Implement without supervision. Make sure the operator has fully read and understands the manuals prior to operation. (SG-4)

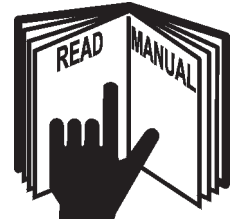

**WARNING!**



Always maintain the safety decals in good readable condition. If the decals are missing, damaged, or unreadable, obtain and install replacement decals immediately. (SG-5)

**WARNING!**



Make certain that the "Slow Moving Vehicle" (SMV) sign is installed in such a way as to be clearly visible and legible. When transporting the Equipment use the Tractor flashing warning lights and follow all local traffic regulations. (SG-6)



**WARNING!**



Operate this Equipment only with a Tractor equipped with an approved roll-over-protective system (ROPS). Always wear seat belts. Serious injury or even death could result from falling off the tractor--particularly during a turnover when the operator could be pinned under the ROPS. (SG-7)



**WARNING!**



Do not modify or alter this Implement. Do not permit anyone to modify or alter this Implement, any of its components or any Implement function. (SG-8)

**DANGER!**



BEFORE leaving the tractor seat, always engage the brake and/or set the tractor transmission in parking gear, disengage the PTO, stop the engine, remove the key, and wait for all moving parts to stop. Place the tractor shift lever into a low range or parking gear to prevent the tractor from rolling. Never dismount a Tractor that is moving or while the engine is running. Operate the Tractor controls from the tractor seat only. (SG-9)

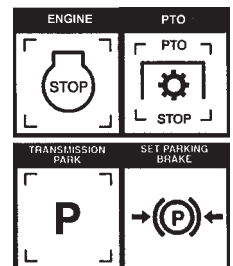

# SAFETY

**DANGER!**



Never allow children or other persons to ride on the Tractor or Implement. Falling off can result in serious injury or death.

(SG-10)



**DANGER!**



Never allow children to operate or ride on the Tractor or Implement.

(SG-11)



**WARNING!**



Do not mount the tractor while the tractor is moving. Mount the tractor only when the tractor and all moving parts are completely stopped.

(SG-12)



**DANGER!**



Start tractor only when properly seated in the tractor seat. Starting a tractor in gear can result in injury or death. Read the tractor operators manual for proper starting instructions. (SG-13)



**DANGER!**



Never work under the Implement, the framework, or any lifted component unless the Implement is securely supported or blocked up to prevent sudden or inadvertent falling which could cause serious injury or even death. (SG-14)



**DANGER!**



Do not operate this Equipment with hydraulic oil leaking. Oil is expensive and its presence could present a hazard. Do not check for leaks with your hand! Use a piece of heavy paper or cardboard. High-pressure oil streams from breaks in the line could penetrate the skin and cause tissue damage including gangrene. If oil does penetrate the skin, have the injury treated immediately by a physician knowledgeable and skilled in this procedure. (SG-15)



# SAFETY

## WARNING!



The operator and all support personnel should wear hard hats, safety shoes, safety glasses, and proper hearing protection at all times for protection from injury including injury from items thrown by the equipment. (SG-16)

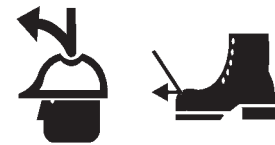

## CAUTION!



**PROLONGED EXPOSURE TO LOUD NOISE MAY CAUSE PERMANENT HEARING LOSS!** Tractors with or without an Implement attached can often be noisy enough to cause permanent hearing loss. We recommend that you always wear hearing protection if the noise in the operator's position exceeds 80db. Noise over 85db over an extended period of time will cause severe hearing loss. Noise over 90db adjacent to the operator over an extended period of time will cause permanent or total hearing loss. *Note:* Hearing loss from loud noise [from tractors, chain saws, radios, and other such sources close to the ear] is cumulative over a lifetime without hope of natural recovery. (SG-17)



## WARNING!



Transport only at safe speeds. Serious accidents and injuries can result from operating this equipment at unsafe speeds. Understand the Tractor and Implement and how it handles before transporting on streets and highways. Make sure the Tractor steering and brakes are in good condition and operate properly.



**Before transporting the Tractor and Implement, determine the safe transport speeds for you and the equipment. Make sure you abide by the following rules:**

1. Test the tractor at a slow speed and increase the speed slowly. Apply the brakes smoothly to determine the stopping characteristics of the Tractor and Implement. As you increase the speed of the Tractor the stopping distance increases. Determine the maximum safe transport speed for you and this equipment.
2. Test the equipment at a slow speed in turns. Increase the speed through the turn only after you determine that it is safe to operate at a higher speed. Use extreme care and reduce your speed when turning sharply to prevent the tractor and implement from turning over. Determine the maximum safe turning speed for you and this equipment before operating on roads or uneven ground.
3. Only transport the Tractor and Implement at the speeds that you have determined are safe and which allow you to properly control the equipment.

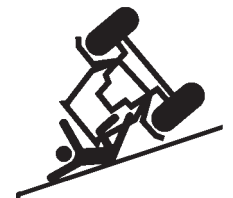

**Be aware of the operating conditions. Do not operate the Tractor with weak or faulty brakes. When operating down a hill or on wet or rain slick roads, the braking distance increases: use extreme care and reduce your speed. When operating in traffic always use the Tractor's flashing warning lights and reduce your speed. Be aware of traffic around you and watch out for the other guy.** (SG-19)

# SAFETY

**WARNING!**



Never attempt to lubricate, adjust, or remove material from the Implement while it is in motion or while tractor engine is running. Make sure the tractor engine is **OFF** before working on the Implement.

(SG-20)

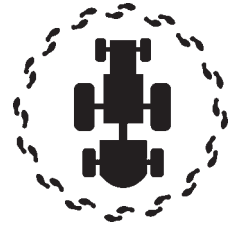

**WARNING!**



Periodically inspect all moving parts for wear and replace when necessary with authorized service parts. Look for loose fasteners, worn or broken parts, and leaky or loose fittings. Make sure all pins are properly secured. Serious injury may occur from not maintaining this machine in good working order. (SG-21)



**WARNING!**



Always read carefully and comply fully with the manufacturers instructions when handling oil, solvents, cleansers, and any other chemical agent. (SG-22)



**DANGER!**



Never run the tractor engine in a closed building or without adequate ventilation. The exhaust fumes can be hazardous to your health.

(SG-23)

**DANGER!**



KEEP AWAY FROM ROTATING ELEMENTS to prevent entanglement and possible serious injury or death. (SG-24)



**DANGER!**



Never allow children to play on or around Tractor or Implement. Children can slip or fall off the Equipment and be injured or killed. Children can cause the Implement to shift or fall crushing themselves or others. (SG-25)

# SAFETY

## DANGER!



**NEVER use drugs or alcohol** immediately before or while operating the Tractor and Implement. Drugs and alcohol will affect an operator's alertness and coordination and therefore affect the operator's ability to operate the equipment safely. Before operating the Tractor or Implement, an operator on prescription or over-the-counter medication must consult a medical professional regarding any side effects of the medication that would hinder their ability to operate the Equipment safely. **NEVER** knowingly allow anyone to operate this equipment when their alertness or coordination is impaired. Serious injury or death to the operator or others could result if the operator is under the influence of drugs or alcohol. (SG-27)

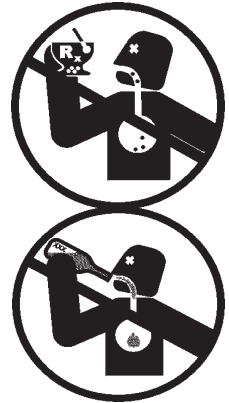

## DANGER!



Operate the Tractor and/or Implement controls only while properly seated in the Tractor seat with the seat belt securely fastened around you. Inadvertent movement of the Tractor or Implement may cause serious injury or death. (SG-29)

## WARNING!



Mow only in conditions where you have clear visibility in daylight or with adequate artificial lighting. Never mow in darkness or foggy conditions where you cannot clearly see at least 100 yards in front and to the sides of the tractor and mower. Make sure that you can clearly see and identify passersby, steep slopes, ditches, drop-offs, overhead obstructions, power lines, debris and foreign objects. If you are unable to clearly see this type of items discontinue mowing. (SGM-1)

## DANGER!



There are obvious and hidden potential hazards in the operation of this Mower. **REMEMBER!** This machine is often operated in heavy brush and in heavy weeds. The Blades of this Mower can throw objects if shields are not properly installed and maintained. Serious injury or even death may occur unless care is taken to insure the safety of the operator, bystanders, or passersby in the area. Do not operate this machine with anyone in the immediate area. Stop mowing if anyone is within 100 yards of mower. (SGM-2)



## DANGER!



All Safety Shields, Guards and Safety devices including (but not limited to) - the Deflectors, Chain Guards, Steel Guards, Gearbox Shields, PTO integral shields, and Retractable Door Shields should be used and maintained in good working condition. All safety devices should be inspected carefully at least daily for missing or broken components. Missing, broken, or worn items must be replaced at once to reduce the possibility of injury or death from thrown objects, entanglement, or blade contact. (SGM-3)

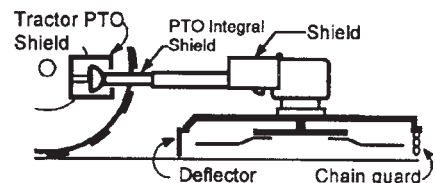

# SAFETY

## DANGER!



The rotating parts of this machine have been designed and tested for rugged use. However, the blades could fail upon impact with heavy, solid objects such as metal guard rails and concrete structures. Such impact could cause the broken objects to be thrown outward at very high velocities. To reduce the possibility of property damage, serious injury, or even death, never allow the cutting blades to contact such obstacles. (SGM-4)

## WARNING!



Extreme care should be taken when operating near loose objects such as gravel, rocks, wire, and other debris. Inspect the area before mowing. Foreign objects should be removed from the site to prevent machine damage and/or bodily injury or even death. Any objects that cannot be removed must be clearly marked and carefully avoided by the operator. Stop mowing immediately if blades strike a foreign object. Repair all damage and make certain rotor or blade carrier is balanced before resuming mowing. (SGM-5)



## WARNING!



Many varied objects, such as wire, cable, rope, or chains, can become entangled in the operating parts of the mower head. These items could then swing outside the housing at greater velocities than the blades. Such a situation is extremely hazardous and could result in serious injury or even death. Inspect the cutting area for such objects before mowing. Remove any like object from the site. Never allow the cutting blades to contact such items. (SGM-6)

## WARNING!



Mow at the speed that you can safely operate and control the tractor and mower. Safe mowing speed depends on terrain condition and grass type, density, and height of cut. Normal ground speed range is from 0 to 5 mph. Use slow mowing speeds when operating on or near steep slopes, ditches, drop-offs, overhead obstructions, power lines, or when debris and foreign objects are to be avoided. (SGM-7)

## WARNING!



Avoid mowing in reverse direction when possible. Check to make sure there are no persons behind the mower and use extreme care when mowing in reverse. Mow only at a slow ground speed where you can safely operate and control the tractor and mower. Never mow an area that you have not inspected and removed debris or foreign material. (SGM-8)

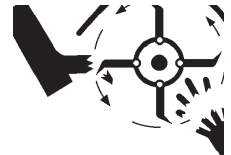

## WARNING!



Do not put hands or feet under mower decks. Blade Contact can result serious injury or even death. Stay away until all motion has stopped and the decks are securely blocked up. (SGM-9)



## DANGER!



Replace bent or broken blade with new blades. NEVER ATTEMPT TO STRAIGHTEN OR WELD ON BLADES SINCE THIS WILL LIKELY CRACK OR OTHERWISE DAMAGE THE BLADE WITH SUBSEQUENT FAILURE AND POSSIBLE SERIOUS INJURY FROM THROWN BLADES. (SGM-10)

# SAFETY

## WARNING!



Do not mow with two machines in the same area except with Cab tractors with the windows closed. (SGM-11)

## DANGER!



Rotary and Flail Mowers are capable under adverse conditions of throwing objects for great distances (100 yards or more) and causing serious injury or death. Follow safety messages carefully.

**STOP MOWING IF PASSERSBY ARE WITHIN 100 YARDS UNLESS:**

- Front and Rear Deflectors are installed and in good, working condition;
- Mower Head is running close to and parallel to the ground without exposed Blades;
- Passersby are outside the existing thrown-object zone;
- All areas have been thoroughly inspected and all foreign material such as rocks, cans, glass, and general debris has been removed.



**NOTE:** Where there are grass and weeds high enough to hide debris that could be struck by the blades, the area should be: inspected and large debris removed, mowed at an intermediate height, inspected closely with any remaining debris being removed, and mowed again at desired final height. (SBM-1)



## DANGER!



Use extreme caution when raising the Mower head. Stop the Blades from turning when the Mower Head is raised and passersby are within 100 yards. Raising the Mower head exposes the Cutting Blades which creates a potentially serious hazard and can cause serious injury by objects thrown from the Blades or by contact with the Blades.

(SBM-2)

## DANGER!



Be particularly careful in transport. The Mower has raised the center of gravity for the tractor and has increased the possibility of overturn. Turn curves or go up slopes only at low speed and using a gradual turning angle. Slow down on rough or uneven surfaces. (SBM-3)



## WARNING!



Never Leave the mower unattended while the head is in the raised position. The mower could fall causing serious injury to anyone who might inadvertently be under the mower.

(SBM-4)



## WARNING!



The rotating parts of this machine continue to rotate even after the Tractor has been turned off. The operator should remain in his seat for 60 seconds after the brake has been set, the PTO disengaged, the tractor turned off, and all evidence of rotation has ceased. (SBM-5)

**“Wait a minute...Save a life!”**



# SAFETY



Relieve hydraulic pressure prior to doing any maintenance or repair work on the Implement. Place the Mower Head on the ground or securely supported on blocks or stands, disengage the PTO, and turn off the engine. Push and pull the control Levers or Joystick several times to relieve pressure prior to starting any maintenance or repair work. (SBM-6)

**DANGER!**



Always keep a careful lookout and use extreme care when working around overhead obstructions. Never allow the Mower head or boom within 10 feet of any power line. When working close to overhead power lines consult your electric company for a safe code of operation. (SBM-7)

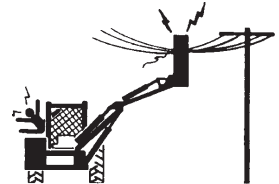

**DANGER!**



When transporting Boom Mower on a truck or trailer, the height or width may exceed legal limits when the boom is in the transport position. Contact with side or overhead structures or power lines can cause property damage or serious injury or death. If necessary lower boom to reduce height and/or remove mowing head to reduce width to the legal limits. (SBM-8)

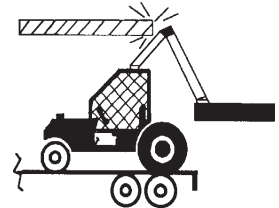

**DANGER!**



Never operate the Tractor and Mower Unit without an OPS (Operators Protective Structure) or Cab to prevent injury from objects thrown from ground or from overhead trimming. Stop mowing if workers or passersby are within 100 yards. (SBM-9)

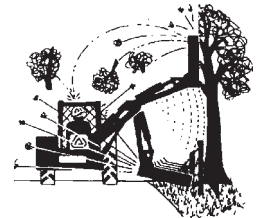

**DANGER!**



Left Rear Wheel must have a minimum of 1500 pound contact with the surface to prevent lateral instability and possible tip-over which could result in serious bodily injury or even death. Widen the wheel tread and add weights if needed. Refer to the mounting instructions or call Customer Service if you need assistance with Counterweight Procedure. (SBM-11)



**DANGER!**



Always disconnect the wire leads from the mower pump solenoid before performing service on the Tractor or Mower. Use caution when working on the Tractor or Mower. Tractor engine must be stopped before working on Mower or Tractor. The Mower Blades could inadvertently be turned on without warning and cause immediate dismemberment, injury or death. (SBM-12a)

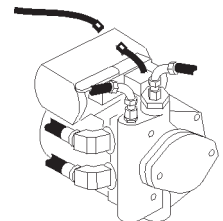

**DANGER!**



The flail cutter shaft is designed for standard rotation (same rotation as the tractor wheels during forward travel). **Never operate the cutter shaft in the reverse rotation.** Operating this mower in reverse rotation may cause objects to be thrown out the front of the mower head.

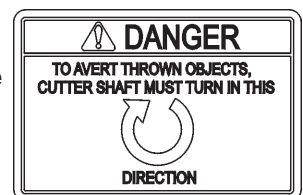

# SAFETY

**WARNING!**



Engine Exhaust, some of its constituents, and certain components contain or emit chemicals known to the state of California to cause cancer and birth or other reproductive harm.

**WARNING!**



Battery posts, terminals and related accessories contain lead and lead compounds, chemicals known to the state of California to cause cancer and birth or other reproductive harm. **Wash hands after handling!**

Tiger mowers use balanced and matched system components for blade carriers, blades, cutter-shafts, knives, knife hangers, rollers, drive-train components and bearings. These parts are made and tested to Tiger specifications. Non-genuine “will fit” parts do not consistently meet these specifications. The use of “will fit” parts may reduce mower performance, void mower warranties and present a safety hazard. Use genuine Tiger mower parts for economy and safety.

SEE YOUR  DEALER

**In addition to the design and configuration of this Implement, including Safety Signs and Safety Equipment, hazard control and accident prevention are dependent upon the awareness, concern, prudence, and proper training of personnel involved in the operation, transport, maintenance, and storage of the machine. Refer also to Safety Messages and operation instruction in each of the appropriate sections of the Tractor and Equipment Manuals. Pay close attention to the Safety Signs affixed to the Tractor and Equipment. (SG-18)**

# SAFETY

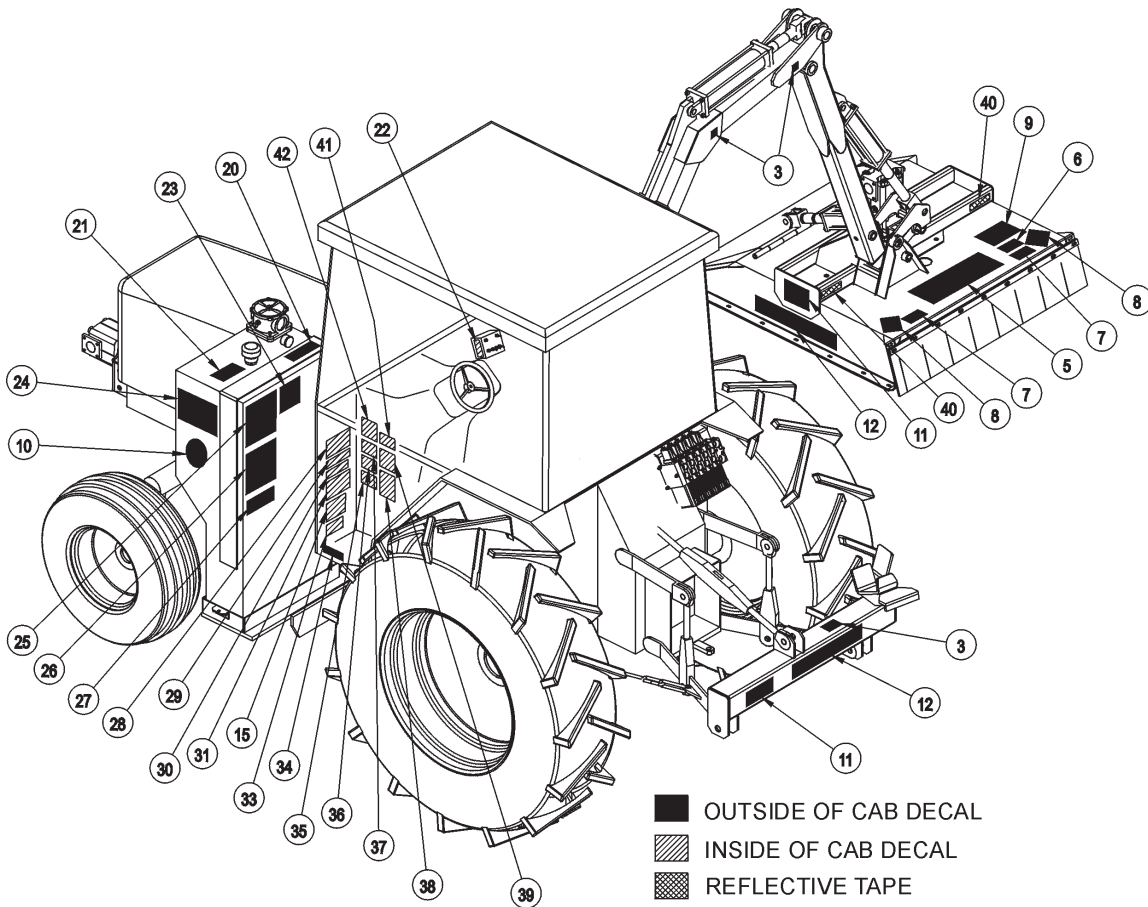

ITEM	PART NO.	QTY.	DESCRIPTION	TRACTOR DECALS
	<b>33514</b>	<b>AVAIL</b>	<b>DECAL KIT CHEETAH TRACTOR</b>	
1	33302	1	JOYSTICK OPERATION (CAB)	
1	34206	1	LEVER OPERATION (NON CAB)	
2	22645	1	POLYCARBONATE WINDOW	
3	02962764	6	WARNING, PINCH POINT	
5	33436	1	DECAL, CHEETAH	
10	6T3236	1	DECAL, MADE IN U.S.A.	
11	33438	2	DECAL, TIGER LOGO	
12	33437	2	DECAL, CHEETAH	
15	33224	1	DANGER, SHIELD BOOM	
18	02962765	1	DANGER, MULTIPLE HAZARD	
19	6T3220	1	CAUTION, LUB PUMP DRIVE	
20	6T3233	2	CAUTION, GATE VALVE	
21	32708	1	DECAL, UNIVERSAL HYDRAULIC OIL	
22	6T3222	1	DECAL, CONTROL ON/OFF SWITCH	
23	02965262	1	WARNING, HOSE BURST	
24	33435	1	DECAL, CHEETAH	
25	32707	1	WARNING, TRACTOR OPERATOR SAFETY	
26	002369	1	DANGER, MULTIPLE HAZARD	
27	02971123	1	WARNING, PRESSURIZED TANK	
28	6T3225	1	DANGER, LINE VOLTAGE	
30	07725746	1	DECAL, SPANISH TRANSLATION	
31	32709	1	DECAL, REPLACEMENT PARTS	
33	6T3237	1	WARNING, CUTTING WITH BRUSH	
34	03200285	1	WARNING, WATCH YOUR STEP	
37	25387	1	WARNING, RELIEVE PRESSURE ACCUMULATED	
38	6T3219	1	WARNING, FOR SAFE OPERATION	
39	22840	1	WARNING, FOREIGN OBJECTS	

# SAFETY

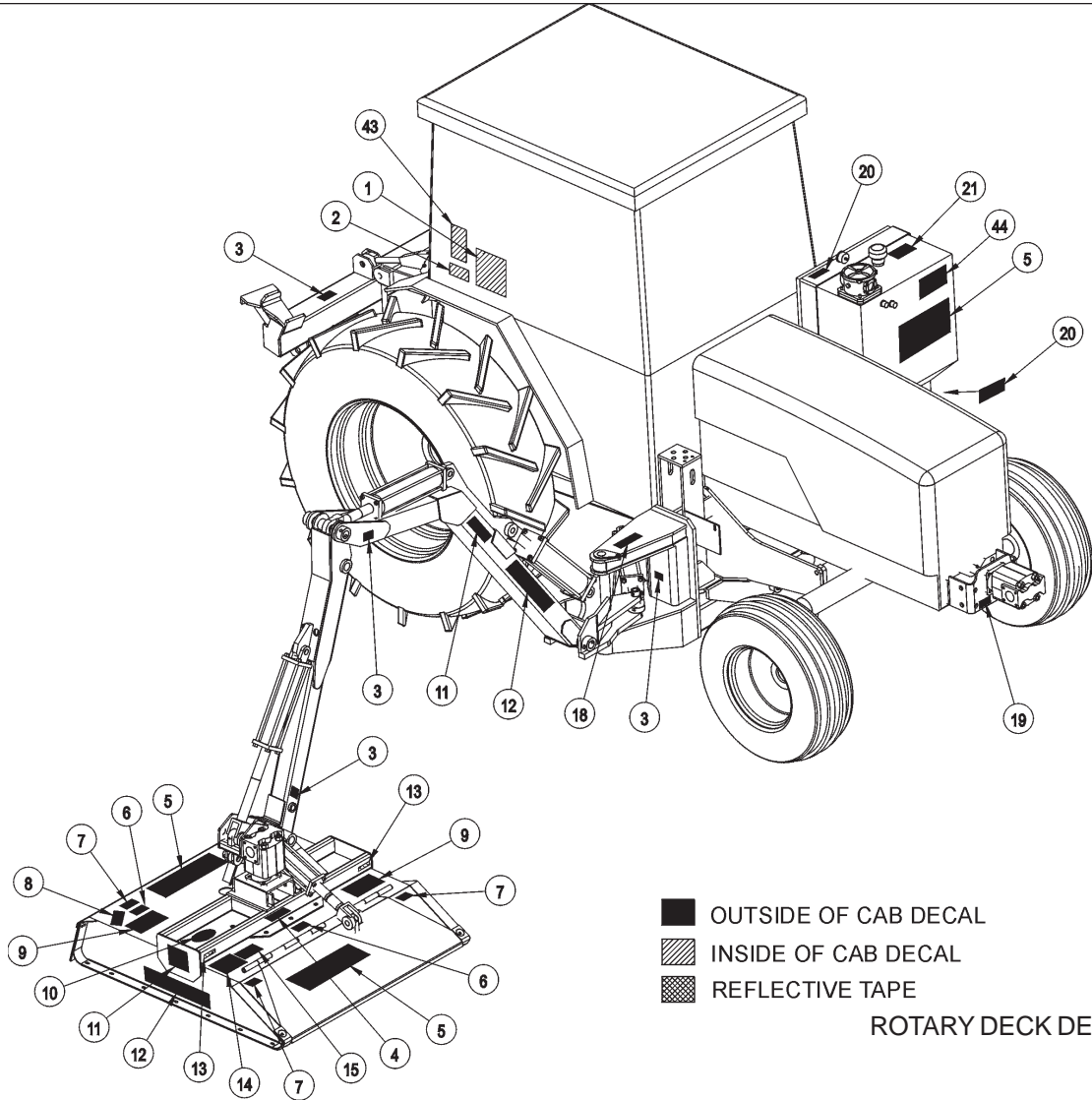

ITEM	PART NO.	QTY. AVAIL	DESCRIPTION
	<b>33439</b>		<b>DECAL KIT CHEETAH ROTARY</b>
4	22839	1	CAUTION, HAND GREASE ONLY
5	33436	2	DECAL, CHEETAH
6	TB1011	2	WARNING, DO NOT REMOVE SHIELD
7	6T3217	4	DANGER, HANDS / FEET CLEAR
8	6T3224	2	DANGER, DISCHARGE OPEN
9	00769737	2	WARNING, BLADES THROWN OBJECTS
10	6T3236	1	DECAL, MADE IN U.S.A.
11	33438	2	DECAL, TIGER LOGO
12	33437	2	DECAL, CHEETAH
13	42400	2	AMBER REFLECTIVE TAPE
14	42350	1	CAUTION, BLADE ROTATION
15	33224	1	DANGER, SHIELD BOOM
29	6T3243	1	WARNING, KNIFE REPLACEMENT
35	6T3221	1	CAUTION, SPINDLE LUB
36	24028	1	WARNING, REPLACE WORN
40	42399	2	RED REFLECTIVE TAPE
41	6T3234	1	CAUTION, CHECK CRANK SHAFT
42	6T3230	1	WARNING NO BYSTANDERS
43	33743	1	MOWING SAFETY TIPS
44	34852	1	LUBRICATION SPECIFICATION DECAL

# SAFETY

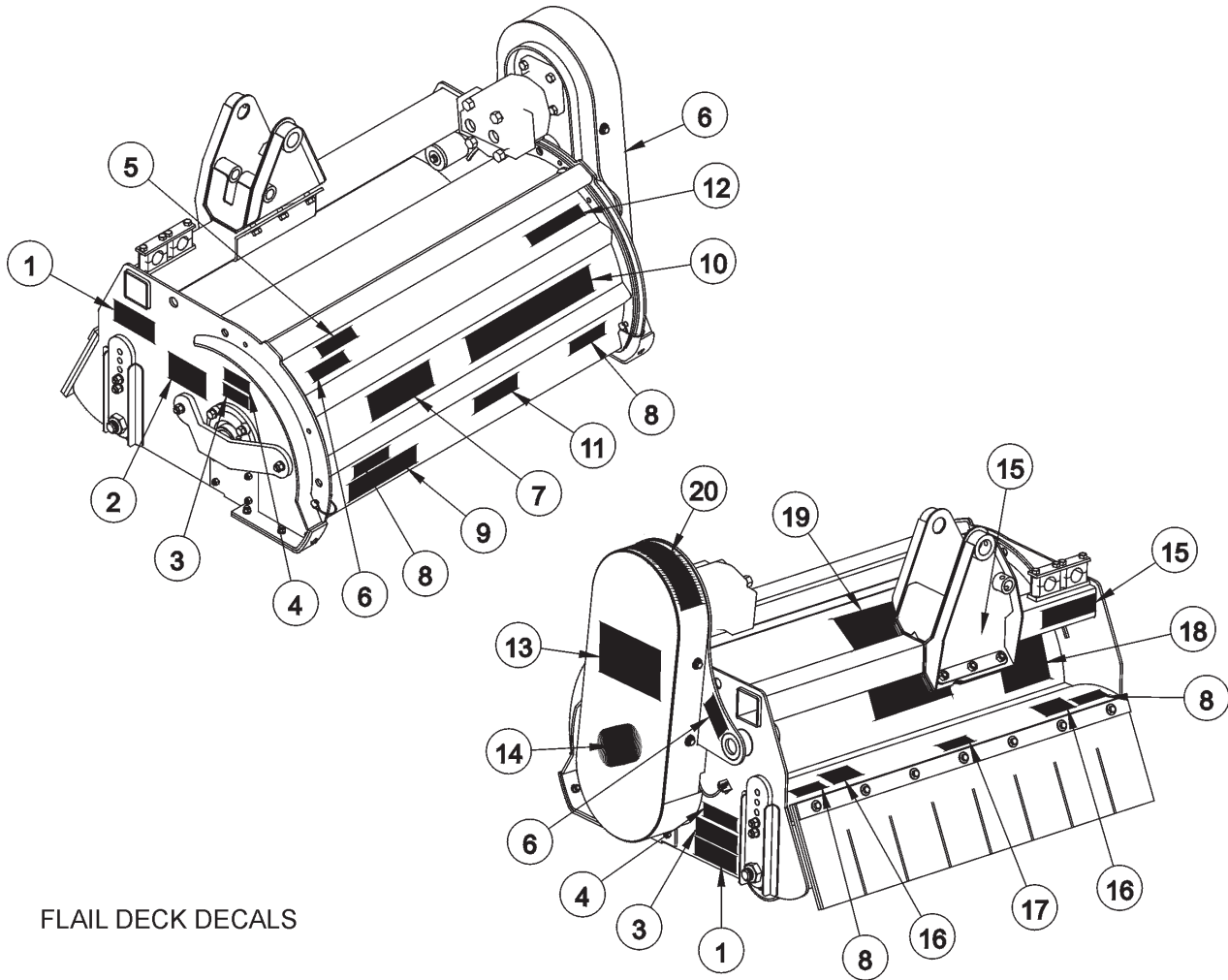

FLAIL DECK DECALS

ITEM	PART NO.	QTY.	DESCRIPTION
	<b>33786</b>	<b>AVAIL</b>	<b>DECAL KIT CHEETAH FLAIL</b>
1	6T3261	2	CAUTION LUBE INSTRUCTIONS
2	42350	1	DECAL, ROTATION, CUTTERSHAFT
3	6T3249A	2	DECAL, CAUTION LUBE
4	22839	2	CAUTION, HAND GREASE
5	33224	1	DANGER, SHIELD
6	TB1011	3	WARNING, DO NOT REMOVE SHIELD
7	33438	2	DECAL, TIGER LOGO
8	6T3217	4	DANGER, HANDS / FEET CLEAR
9	42400	1	AMBER REFLECTIVE TAPE
10	33437	2	DECAL, CHEETAH
11	6T3243	1	WARNING, KNIFE REPLACEMENT
12	02962764	1	WARNING, PINCH POINTS
13	33435	1	DECAL, CHEETAH
14	6T3236	1	DECAL, MADE IN U.S.A.
15	42399	2	RED REFLECTIVE TAPE
16	6T3224	2	DANGER, DISCHARGE OPENING
17	24028	1	WARNING REPLACE WORN FLAP
18	002369	1	DANGER, MULTIPLE HAZARD
19	33436	2	DECAL, CHEETAH
20	00758194	1	WARNING, BELT SHIELD



# SAFETY

DANGER

FAILING TO FOLLOW SAFETY MESSAGES AND OPERATING INSTRUCTIONS CAN CAUSE SERIOUS BODILY INJURY OR EVEN DEATH TO OPERATOR AND OTHERS IN THE AREA.

<p>1. <b>READ MANUAL</b></p>	<p>2. <b>NO RIDERS, NO CHILDREN OPERATORS</b></p>	<p>3. <b>USE SAFETY SHOES, HARD HAT, SAFETY GLASSES, SEAT BELTS, &amp; ROPS</b></p>	<p>4. <b>BLOCK UP SECURELY BEFORE WORKING UNDER</b></p>
------------------------------	---	---	---

1. Study and understand Operator's Manuals, Safety Signs, and Instructional Decals for tractor & flail mower to prevent misuse, abuse, & accidents. Practice before operating mower in a confined area or near passersby.  
 • Learn how to stop engine suddenly in an emergency. Be alert for passersby and especially children.  
 2. Allow no children on or near implement or tractor. Allow no riders on tractor or implement. Falling off can cause serious injury or death from being runover by tractor or mower or contact with Flail Mower Blades.  
 3. Operate only with tractor having Roll-Over Protective Structure (ROPS) and with seatbelt fastened securely and snugly to prevent injury and possible death from falling off or tractor overturn. Personal Protective Equipment such as Hard Hat, Safety Glasses, Safety Shoes, and Ear Plugs are recommended.  
 4. Block up or support raised machine and all lifted components securely before putting hands or feet under or working underneath any lifted component to prevent crushing injury or death from sudden dropping or inadvertent operation of controls. Make certain that area is clear before lowering or folding.  
 5. Before transporting, put Lift Lever in detent or full-lift position. Install Transport Safety Devices securely on folding implements. Slow down when turning and on hillsides.  
 • Install "Restrictor in folding circuit to slow down lowering and unfolding if action is faster than is desirable.  
 6. Make certain that SMV sign, Warning Lights, and Reflectors are clearly visible. Follow local traffic codes.  
 7. Never operate with Flail Mower or Folding Section raised if passersby, bystanders or traffic are in the area to reduce possibility of injury or death from objects thrown by Blades under Shields or implement structure.  
 8. Before dismounting, secure flail mower in transport position or lower to ground.  
 • Put tractor in park or set brake, disengage PTO, stop engine, remove key, and wait until noise of rotation has ceased to prevent entanglement in rotating parts which may cause injury or death.  
 • Never mount or dismount a moving vehicle. Crushing from runover may cause injury or death.

<p>5. <b>TRANSPORT SAFELY, LOCK UP</b></p>	<p>6. <b>USE SMV, LIGHTS, &amp; REFLECTORS</b></p>	<p>7. <b>DONOT OPERATE WITH MOWER OR WING RAISED</b></p>	<p>8. <b>DO NOT MOUNT OR DISMOUNT WHILE MOVING</b></p>
--	--	--	--

002369

PELIGRO

Si No Lee Ingles, Pida Ayuda a Alguien Que Si Lo Lea Para Que le Traduzca las Medidas de Seguridad.

LEA EL INSTRUCTIVO

00725746

00725746

DANGER

THROWN OBJECTS

CUTTING BLADES

KEEP AWAY - ROTATING BLADES

BEING HIT BY THROWN OBJECTS OR CONTACTING ROTATING BLADES CAN CAUSE INJURY OR DEATH.

- Stop mowing if passersby enter the area of thrown objects (See Operator's Manual).
- Use special care if Mower Head or Wing is raised off the ground. (See Manual).
- Operate only if all Guards-Deflectors are in place and in good condition.

00769737

00769737

# SAFETY



02962764



02962765

02965262



# SAFETY

02971123



03200285



22645

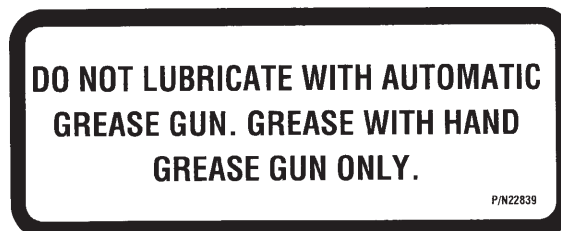

22839

# SAFETY



22840



24028

25387

# SAFETY

## DANGER

1. EACH REAR WHEEL MUST HAVE A MINIMUM OF 1500 POUNDS CONTACT WITH THE SURFACE TO PREVENT LATERAL INSTABILITY AND POSSIBLE TIP-OVER WITH BODILY INJURY. WIDEN WHEEL TREAD AND ADD WEIGHTS IF NEEDED. SEE MANUAL OR CALL TIGER CUSTOMER SERVICE FOR COUNTERWEIGHT PROCEDURE.

2. TRANSPORT CAREFULLY! SLOW DOWN EVEN MORE ON SLOPES AND WHEN TURNING, NEVER TURN UP A SLOPE SHARPLY OR AT HIGH SPEED; AND USE EXTRA CARE IN ROUGH OR BUMPY AREAS TO PREVENT OVERTURN AND POSSIBLE CRUSHING INJURY OR DEATH. IF YOUR VIEW TO THE REAR IS BLOCKED, IT IS YOUR RESPONSIBILITY TO INSTALL MIRRORS THAT PROVIDE A REAR VIEW TO PREVENT ACCIDENTS FROM BLIND SPOTS.

3. REAR-MOUNTED BOOM MOWERS MOVE CENTER OF GRAVITY TO THE REAR AND REMOVE WEIGHT FROM FRONT WHEELS. ADD FRONT BALLAST UNTIL AT LEAST 20% OF TRACTOR'S WEIGHT IS ON FRONT WHEELS TO PREVENT REARING UP, LOSS OF STEERING CONTROL, AND POSSIBLE INJURY.

4. NEVER OPERATE UNIT WITHOUT AN OPS (OPERATOR PROTECTIVE STRUCTURE) OR CAB TO PREVENT INJURY FROM OBJECTS THROWN FROM GROUND AND OVERHEAD TRIMMING. STOP CUTTING IF ANYONE IS WITHIN 100 YARDS.

5. KEEP THE BOOM AND CUTTERHEAD AT LEAST 10 FEET FROM ELECTRIC LINES AND PIPE LINES TO PREVENT ACCIDENTAL CONTACT AND POSSIBLE SERIOUS INJURY OR EVEN DEATH.

6. WHEN TRANSPORTING BOOM MOWERS ON A TRUCK OR TRAILER, THE HEIGHT OR WIDTH MAY EXCEED LEGAL LIMITS. CONTACT WITH SIDE OR OVERHEAD STRUCTURES OR POWER LINES CAN CAUSE SERIOUS INJURY OR DEATH. LOWER BOOM TO REDUCE HEIGHT AND/OR REMOVE MOWING HEAD TO REDUCE WIDTH TO THE LEGAL LIMITS, IF NEEDED.

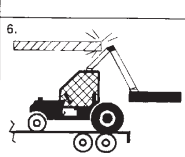
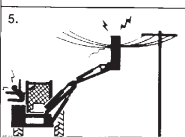
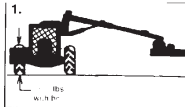

32707

## ATTENTION

**SERVICE HYDRAULIC SYSTEM  
WITH UNIVERSAL TRACTOR  
HYDRAULIC OIL.**

32708

32708

## CAUTION

For your safety and to guarantee optimum product reliability, always use genuine TIGER replacement parts. The use of inferior "will-fit" parts will void warranty of your TIGER implement and may cause premature or catastrophic failure which can result in serious injury or death. If you have any questions concerning the repair parts you are using, contact TIGER, 3301 N. LOUISE AVE., SIOUX FALLS, SD 57107

32709

32709

# SAFETY

33224

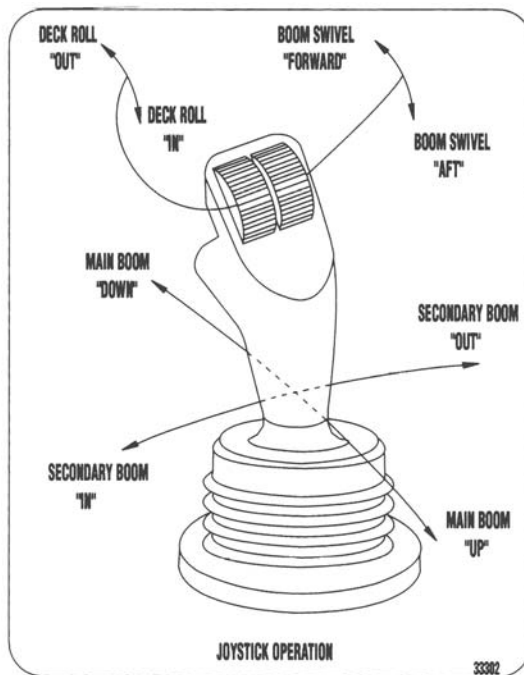

33302



33435

# SAFETY



33436



33437



33438



42350



RED

42399

# SAFETY



AMBER

42400



6T3217

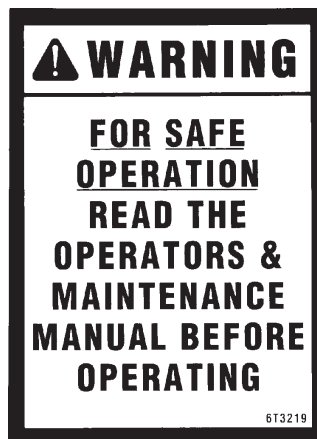

6T3219

6T3220



6T3221

# SAFETY



6T3222



6T3224

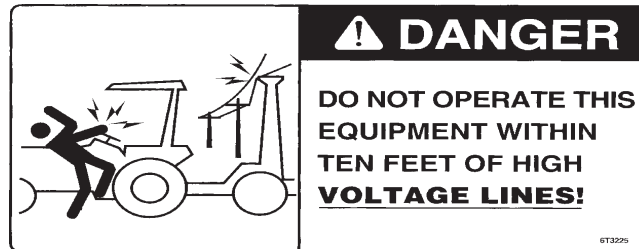

6T3225

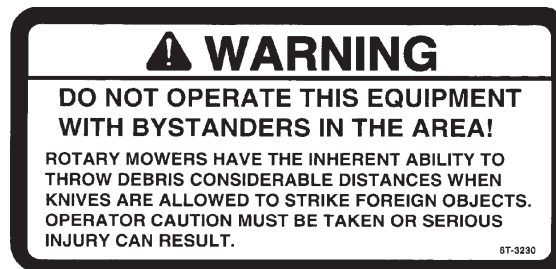

6T3230



6T3233



# SAFETY



6T3234



6T3236

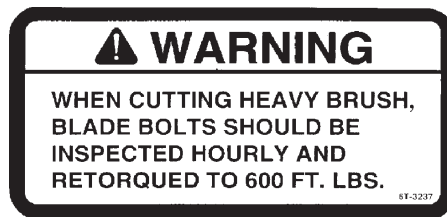

6T3237

6T3237

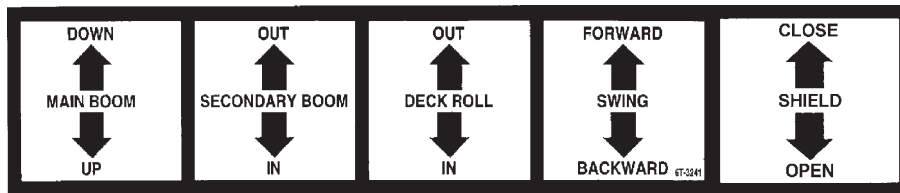

34206

# SAFETY

 <b>WARNING</b>	<b>IMPORTANT</b>
IT IS RECOMMENDED THAT THE BOLT AND LOCK NUT BE REPLACED WHENEVER BLADES ARE REPLACED. REPLACE THESE ANY TIME THEY ARE DAMAGED OR WORN AS FAILURE TO DO SO CAN LEAD TO BLADES COMING OFF CAUSING SERIOUS INJURY OR DEATH.	• WHEN REPLACING BLADES, IT IS RECOMMENDED THAT ALL BLADES BE REPLACED FOR PROPER BALANCE TO AVOID EXCESSIVE VIBRATIONS WHICH CAN DAMAGE SPINDLE ASSEMBLY. • SEE YOUR OPERATOR'S MANUAL FOR PROPER INSTALLATION INSTRUCTIONS.

6T-3243

 **WARNING**













**DO NOT OPERATE MOWER  
WITH SAFETY SHIELD REMOVED.**

TB1011

6T3243

TB1011

**MOWING  
SAFETY TIPS**

-  Read & understand the Operators Manual.
-  Wear Your Seat Belt.
-  Keep all shields and guards in place.
-  Make sure equipment is in proper working condition.
  
-  Never attempt to get off or on a moving tractor.
  
-  Never allow riders on tractor or equipment.
-  Only start the tractor from the seat with the key.
  
-  Always inspect the area before mowing. Remove all foreign debris.
  
-  Always keep bystanders and coworkers a minimum of 300 feet away.
  
-  Never allow the mower blades to contact solid objects or foreign material.
  
-  Never approach rotating elements.
-  Disengage the PTO, place transmission in "Park", set parking brake, shut off engine, and remove key and wait until all rotating motion has stopped before leaving seat.



33743

33743

# SAFETY



**Tiger Corporation**

800-843-6849

www.tiger-mowers.com

Description	Application	General Specification	Recommended Lubricant
Tractor Hydraulics	Reservoir	JD-20C	Mobilfluid® 424
Mower Hydraulics Cold Temperatures 0°F Start-up  Normal Temperatures 10°F Start-up Normal Temperatures 15°F Start-up High Operating Temperatures Above 90°F Ambient	Reservoir	ISO 46 Anti-Wear/ Low Temp JD-20C ISO 46 Anti-Wear ISO 100 Anti-Wear	Mobil DTE® 15M  Mobilfluid® 424 Mobil DTE® 25 Mobil DTE® 18M
Flail Rear Gearbox	Reservoir	PAO Synthetic Extreme Pressure Gear Lube	Mobilube SHC® 75W-90, Mobil 1 Synthetic Gear Lubricant
Cutter Shaft and Ground Roller Shaft (Flail)	Grease Gun	Lithium Complex, NLGI 2 ISO 320	Mobilgrease® CM-S
Drive Shaft Coupler (Rotary and Flail)	Grease Gun	Lithium Complex, NLGI 2 ISO 320	Mobilgrease® CM-S
Boom Swivel, Boom Cylinder Pivots (Rotary and Flail Boom Type)	Grease Gun	Lithium Complex, NLGI 2 ISO 320	Mobilgrease® CM-S
Deck Boom Pivot & Deck Stop Adjustment (Rotary and Flail)	Grease Gun	Lithium Complex, NLGI 2 ISO 320	Mobilgrease® CM-S
Deck Spindle (Rotary)	Grease Gun	Tiger Spindle Lubricant	Mobilith SHC 220

**For Mobil product information, availability, or technical information, call 1-800-662-4525.**

Tiger PN 34852

34852  
HYDRAULIC TANK

# SAFETY

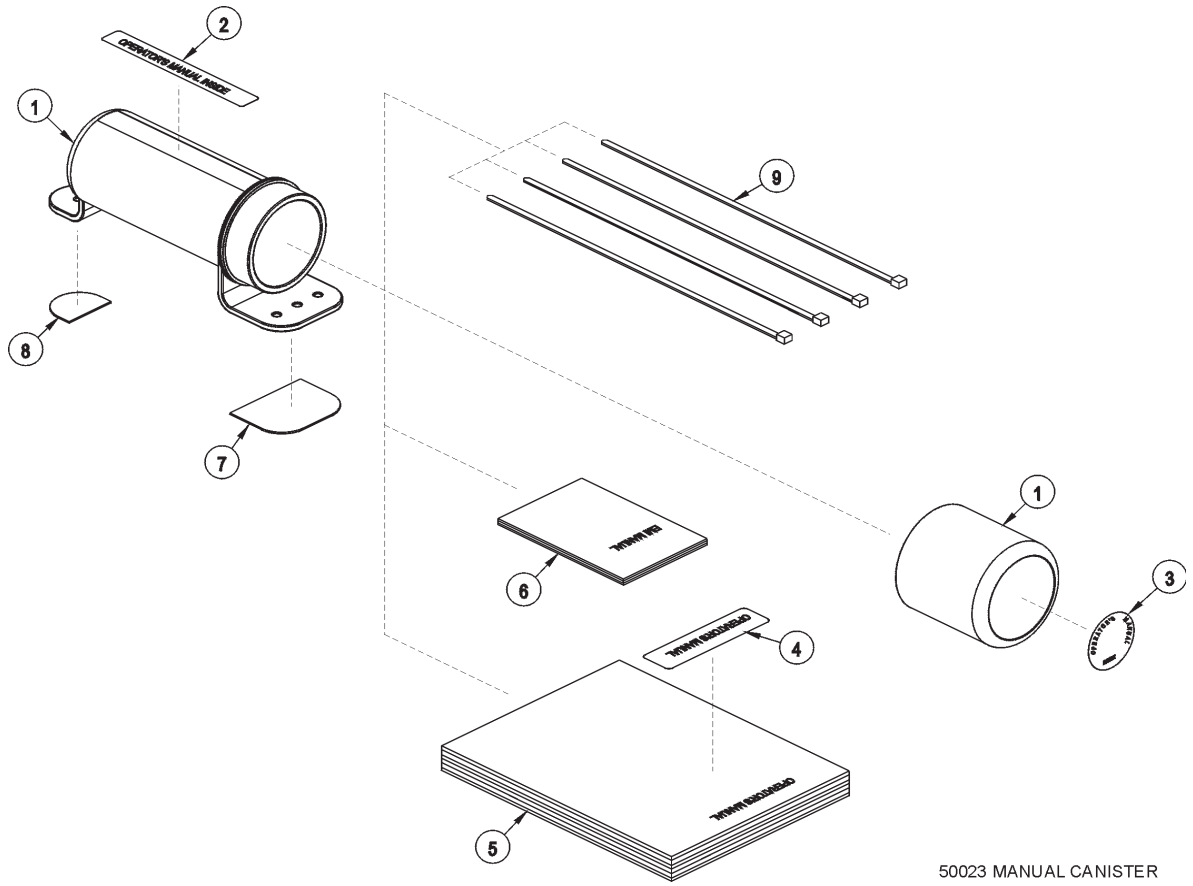

50023 MANUAL CANISTER

ITEM	PART NO.	QTY.	DESCRIPTION
	<b>50023</b>	<b>AVAIL</b>	<b>MANUAL CANISTER COMPLETE</b>
1	00776031	1	ROUND MANUAL CANISTER
	33997	1	DECAL, SHEET, MANUAL CANISTER
2		*	DECAL
3		*	DECAL
4		*	DECAL
5	*	AVAIL	SPECIFIC PRODUCT MANUAL
6	33753	1	E M I SAFETY MANUAL
7	34296	1	FRONT ADHESIVE PAD
8	34297	1	REAR ADHESIVE PAD
9	6T1823	4	ZIPTIE 14" LONG

**NOTE:**

The manual canister can be bolted, zip tied or adhered to a variety of surfaces. Locate a protected area within the view of the operator. Then select an installation method and attach the canister. **CAUTION - AVOID DRILLING HOLES INTO UNKNOWN AREAS**, wires and other parts may be located behind these areas. When adhering the canister to a surface, thoroughly clean that surface before installing the canister.

# SAFETY

## FEDERAL LAWS AND REGULATIONS

This section is intended to explain in broad terms the concept and effect of federal laws and regulations concerning employer and employee equipment operators. This section is not intended as a legal interpretation of the law and should not be considered as such.

### Employer-Employee Operator Regulations

U.S. Public Law 91-596 (The Williams-Steiger Occupational and Health Act of 1970) OSHA

#### This Act Seeks:

“...to assure so far as possible every working man and woman in the nation safe and healthful working conditions and to preserve our human resources...”

### DUTIES

Sec. 5 (a) Each employer-

(1) shall furnish to each of his employees employment and a place of employment which are free from recognized hazards that are causing or are likely to cause death or serious physical harm to his employees;

(2) shall comply with occupational safety and health standards promulgated under this Act.

(b) Each employee shall comply with occupational safety and health standards and all rules, regulations and orders issued pursuant to this Act which are applicable to his own actions and conduct.

### OSHA Regulations

OSHA regulations state in part: “At the time of initial assignment and at least annually thereafter, the employer shall instruct every employee in the safe operation and servicing of all equipment with which the employee is, or will be involved.”

### Employer Responsibilities:

To ensure employee safety during Tractor and Implement operation, it is the employer’s responsibility to:

1. Train the employee in the proper and safe operation of the Tractor and Implement.
2. Require that the employee read and fully understand the Tractor and Implement Operator’s manual.
3. Permit only qualified and properly trained employees to operate the Tractor and Implement.
4. Maintain the Tractor and Implement in a safe operational condition and maintain all shields and guards on the equipment.
5. Ensure the Tractor is equipped with a functional ROPS and seat belt and require that the employee operator securely fasten the safety belt and operate with the ROPS in the raised position at all times.
6. Forbid the employee operator to carry additional riders on the Tractor or Implement.
7. Provide the required tools to maintain the Tractor and Implement in a good safe working condition and provide the necessary support devices to secure the equipment safely while performing repairs and service.

### Child Labor Under 16 Years of Age

Some regulations specify that no one under the age of 16 may operate power machinery. It is your responsibility to know what these regulations are in your own area or situation. (Refer to U.S. Dept. of Labor, Employment Standard Administration, Wage & Home Division, Child Labor Bulletin #102.)

# **ASSEMBLY SECTION**

# ASSEMBLY

**Before attempting to mount or service your Tiger mower, it is important to read and understand all of the information in the Safety section of this manual.**

Check complete shipment list against the packing list to make sure there are no shortages. Make certain the tractor model is the appropriate one for the mower received!

**CAUTION!**



Use a floor jack, hoist or fork lift to lift or raise heavy parts whenever possible whether mentioned or not.

Read and understand the entire assembly section instructions before attempting to mount your Tiger mower. Refer to the parts section of this manual for detailed illustrations to locate all parts.

## TRACTOR PREPARATION

- A: Remove right hand steps.
- B: Disconnect cables from both batteries, (remove batteries and the battery box from cab units only.)
- C: Remove engine side panels, or raise hood to access front pulley.
- D: Remove plugs from tractor casting where main frame and pump mount will be attached.
- E: Raise the tractor onto jack-stands and remove the right rear wheels.

## CRANKSHAFT ADAPTER

If necessary remove the four cap-screws from the crankshaft pulley. Then install the crankshaft adapter and spacer to the pulley with cap-screws and lock-washers as shown in the parts section

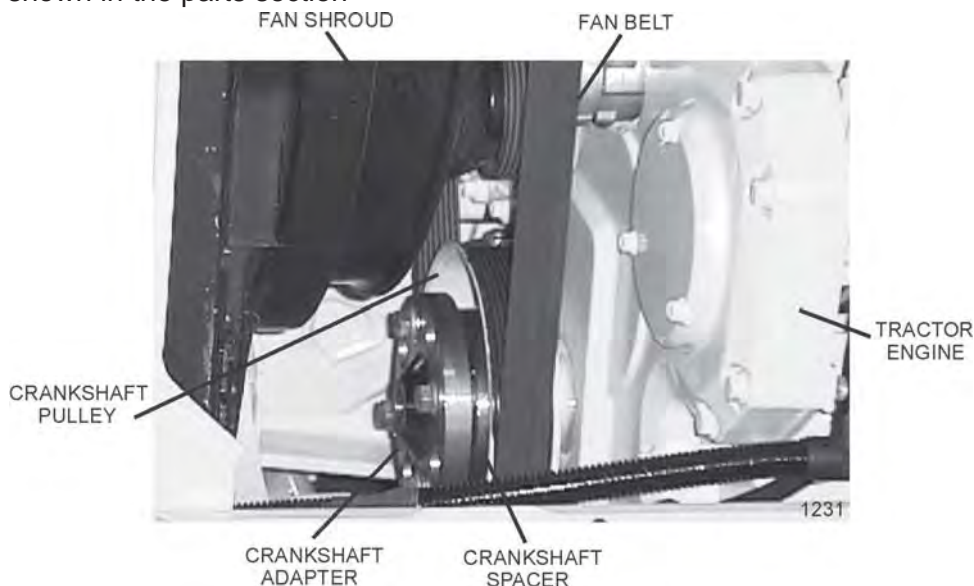



# ASSEMBLY

## POLYCARBONATE SAFETY WINDOW

**NOTE:** In most cases this should be done before mounting the main frame. Carefully remove the existing right rear cab window, to be replaced with the matching polycarbonate window provided.

Clean all of the surfaces around the window opening, once the rear window is removed. Peel back the protective paper from the area around the window that will contact the window frame. Apply a bead of urethane window adhesive, supplied in kit, around the window opening. Carefully position the new window into position. Fill the remainder of the gap around the window with the adhesive, to finish. Be sure to follow the instructions on the adhesive label when installing window.

Next, install the upper and lower door hinges **along with the existing** cab door hinges. To do this, you will remove the existing hinge hardware and install the existing hardware on the polycarbonate as shown. Set the safety screen assembly on the hinges and attach the door to the tractor frame. Install the brackets with the hardware shown in the parts section. Assemble the rod with the vibration isolator and nuts and attach them to the brackets. Adjust the vibration isolator on the upper and lower brackets to achieve a good fit with the window.

Installing a boom mower requires that all right side windows be replaced or shielded by a lexan safety window.

## ADJUSTING REAR WHEELS

Raise rear of tractor onto jack-stands and adjust tires / rims all the way out. **Follow the instructions in the tractor owners manual for adjusting tires and rims.** **NOTE:** This may require switching the wheels to opposite sides of tractor. Do not reinstall wheels onto tractor until valve has been mounted (cab), and all hoses have been installed

## MAIN FRAME MOUNTING

It may be necessary to raise the front of the tractor slightly to allow the main frame to be slid under the tractor. With an overhead hoist or floor jack, slide the frame under the tractor from the right hand side. Raise the frame up to the correctly matching mounting holes. Install the capscrews and all other hardware as shown in the main frame parts section. Remove the capscrews one at a time and apply a Loc-Tite to the threads. Reinsert the capscrews and tighten / torque to the values noted in the torque chart located in the maintenance section of this manual.

# ASSEMBLY

## AXLE BRACE

Position the right axle brace under the tractor right hand side. Raise the brace up to the matching mounting holes in the main frame and rear axle housing. Note the right side brace is installed on outside edge of the main frame and the left side brace is installed on the inside edge of the main frame. Pictures below show right side brace installation. Install the axle plate with capscrews, washers and nuts as shown in the main frame parts section. Apply Loc-Tite to the threads and torque to the values noted in the torque chart located in the maintenance section of this manual.

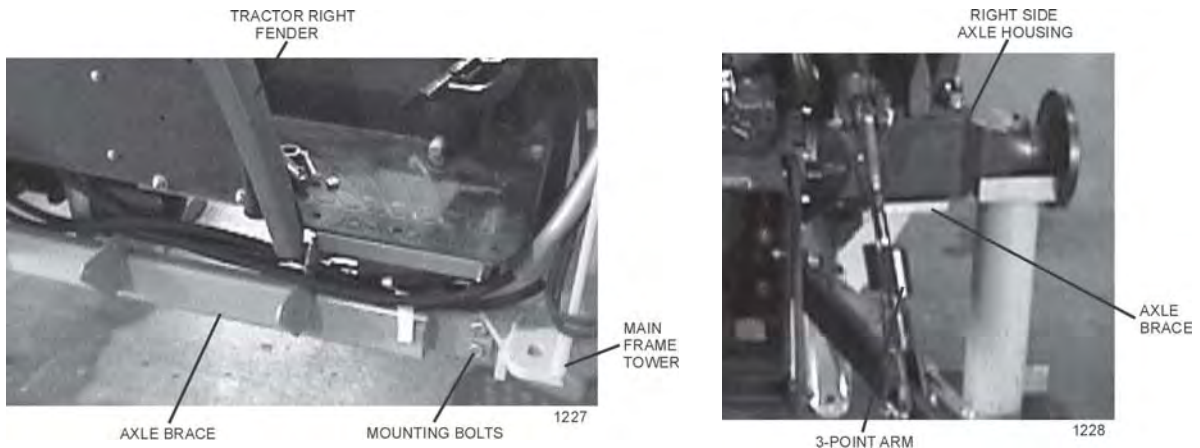

## 3-POINT BOOM REST MOUNTING

Before installing the rear boom rest onto the 3-point hitch, you must set the 3-point stop lever (to the right of the seat) to setting "4" and lock into position as shown below. (See tractor owners manual for further instruction on use of the 3-point hitch stops.) Next, install the boom rest onto the 3-point hitch using the pins as shown in the parts illustration. Adjust the top link so that the boom saddle is approximately level with the ground. NOTE: Top link will need to be adjusted once the boom is completely installed and operable. To do this, carefully rotate the boom along side of the cab and into the boom rest. Adjust the top link until the boom is properly seated in the boom rest and no part of the boom (including hoses) comes into contact with the tractor cab. Next, using the side turnbuckles, adjust the boom and boom rest all the way to the right for proper width restrictions. Check your local width regulations before transporting your mower.

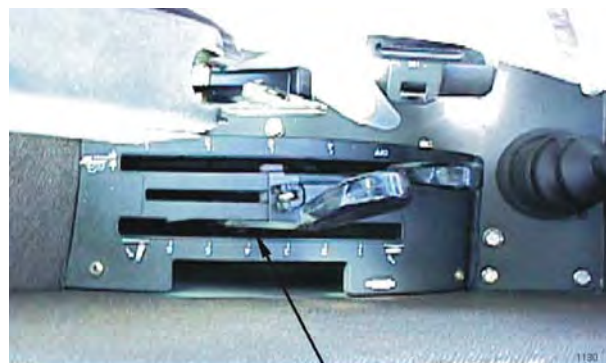

PLACE LEVER NEXT TO SETTING  
#4 AND LOCK INTO POSITION

# ASSEMBLY

## JOYSTICK SWITCH BOX MOUNTING

Locate the 2 existing threaded holes in the right front corner of the cab frame. These will be the mounting holes for the 2 mounting bolts of the switch box bracket. See picture below. Mount the bracket using the hardware supplied, as noted in the parts section.

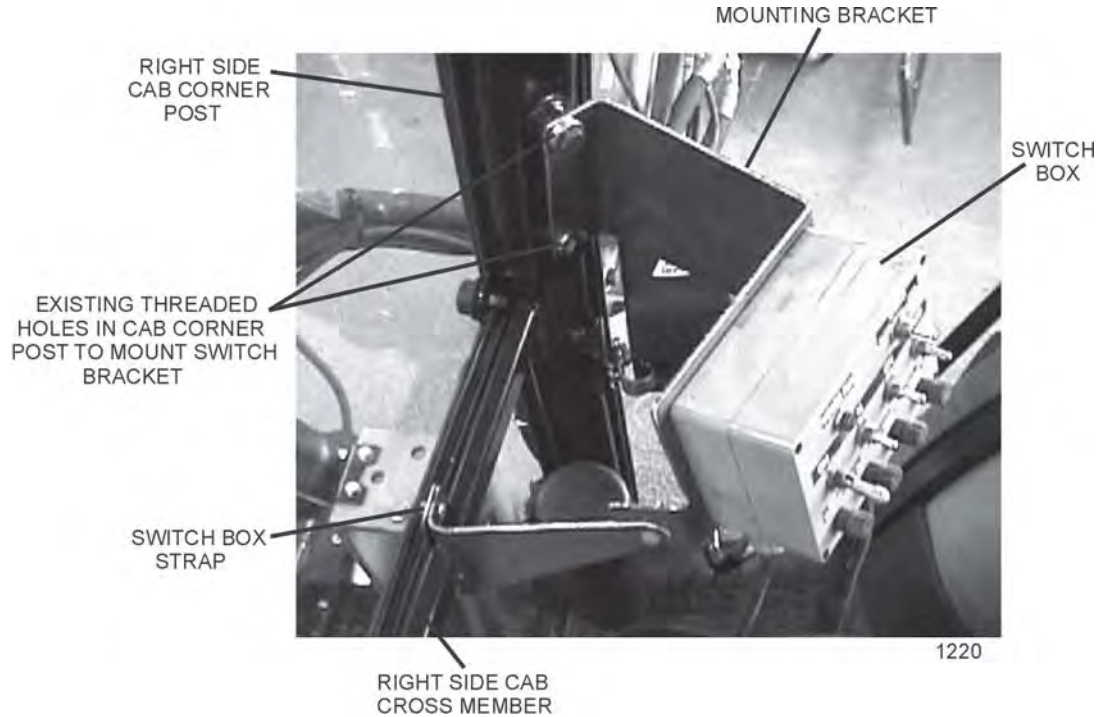

# ASSEMBLY

## JOYSTICK SWITCH BOX WIRING

Refer to the parts section for the danfoss wiring schematic to hook up the switch box. Cover all wires with plastic wire wrap provided. Route the green wires along switch box bracket and cab frame to the steering wheel console. Route the rest of the wires along the base of the right hand console and up to the rubber boot in the bottom right corner in the rear window of the cab. The red and black wires will be connected to the auxillary power plug in the back of the cab. After all wiring is complete, secure all wires to the console with zip ties and push mounts. Take up most of the slack so the wires are out of the way and tighten the zip-ties.

With the panel under the steering wheel removed to access the wires, locate the brown wire and verify that this is the neutral safety wire with a test light or meter. Then cut the brown wire and connect a green wire from the switch box to each end of the brown wire as shown in the wiring diagram. Cut a small hole for the green wires and the wire wrap to fit through and replace the console.

The red and black wires access power for the switchbox through a John Deere auxillary power plug in the rear of the cab.

**NOTE: The RED wire from the JD power plug should not be used because it is ALWAYS "Hot". +12 VOLTS ELECTRICAL POWER MUST BE TAKEN FROM A SOURCE LOCATION WHERE IT IS LIVE ONLY WHEN THE IGNITION SWITCH IS IN THE "ON" POSITION. THE RED WIRE MUST BE FUSED AT THE SOURCE LOCATION WITH A CLOSED END CONNECTOR (# 34538).**

Connect the red wire from the switch box to the orange wire from the JD power plug. Connect the black wire from the switch box to the black wire from the JD power plug.

Two sets of wires have Metri-Pak ends on them. The white and black wires plug into the brake valve. The orange and black wires plug into the travel lock.

Cut a cross hair pattern in the rubber boot in the right bottom corner of the rear window. The wires can be routed through and the rubber falls back into position. The hole should only be large enough for the wires to go through easily.

Route the Metri-Pak wires from the window boot to their location on the unit. Coil the excess wire and secure it to the tractor frame with zip ties to eliminate vibration and rubbing.

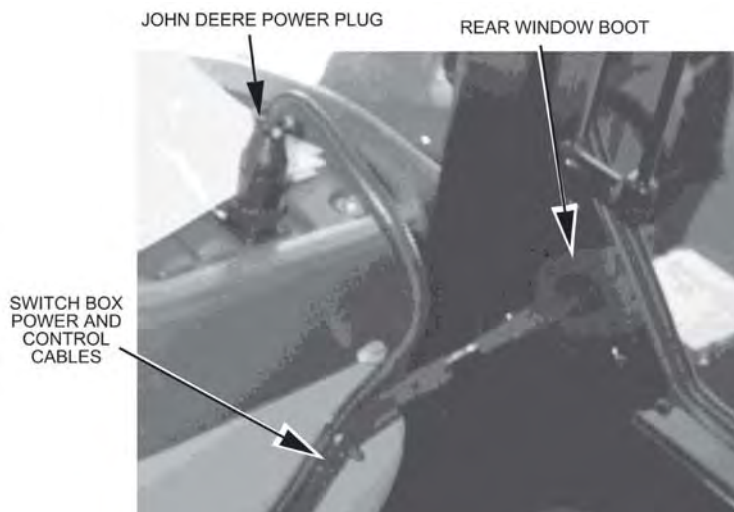

34538 - CLOSED END CONNECTOR



**NOTE:** When cutting or drilling a hole, be sure not to damage existing wires running behind panels.

# ASSEMBLY

## JOYSTICK CONTROL MOUNTING

The joystick is mounted to the right hand center cab post. Find the two existing bolts above the area where the post bumps out. See the image below. Mount the joystick mounting bracket to the cab post with hardware provided. Assemble the parts as shown in the parts section. When operating the joystick, make sure it is positioned where the rest of the controls are fully operational.



CAB POST  
BOLTS



## VALVE MOUNTING

Attach the rear valve mounting bracket to the fender of the tractor by removing the two rear bolts on diesel tank and the two rear bolts of the tank on the opposite fender. Use the hardware noted in the parts section to attach the valve mounting bracket to the tractor.

Next, attach the valve mounting plate to the mounting bracket. Align the holes on the plate to the holes on the bracket. Use the hardware shown in the parts section to attach the plate to the valve mounting bracket.

Finally, place the valve on the valve mounting plate as shown in the parts section. Align the holes on the valve assembly to the holes on the plate. Use the hardware provided to secure the valve to the plate. Refer to the parts section for the placement of the valve and the hardware used. **Please handle the lift valve with care. It is extremely heavy and contains small parts.**



# ASSEMBLY

## DANFOSS VALVE PLUMBING (SCV ONLY UNITS)

A priority valve will be used to power the danfoss valve. The tractor ports used are on the selective control valve (SCV). The SCV is located between the right arm of the three point hitch and the axle. The pressure port is located the closest to the axle. The excessive flow port is right next to the pressure port. And the return port is located on the adjacent face. Refer to the image below as a guide.

NOTE: To use the pressure port a 3/8 NPT pipe plug(B) must be inserted into the port(C) - (refer to the illustration below and the Parts Section). Remove the plugs covering the ports of the SCV ports. After the plug is removed, use a wrench to tighten the plug(B) securely.

### SELECTIVE CONTROL VALVE (SCV)

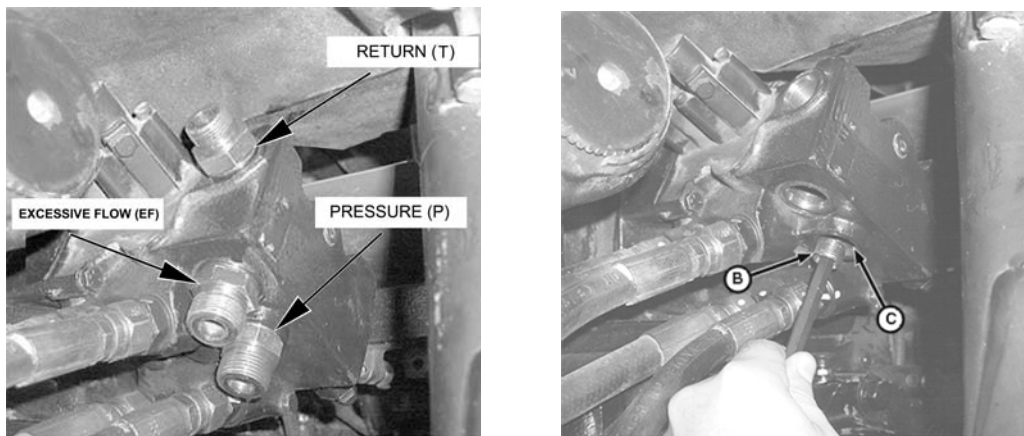

When the pressure port is active, install the adapters in their ports. The hose from the pressure port goes to the "P" port of the priority valve. Next the hose from the "CF" port on the valve goes to the "P" port on the Danfoss lift valve. The return hose from the lift valve goes back to the "T" port on the selective control valve. Plumb the excessive flow hose from the "EF" port on the priority valve to the "EF" port on the SCV. Then the load sense hose goes from the "LS" port on the priority valve to the "LS" port on the lift valve. See the parts pages for placement and the hardware used.

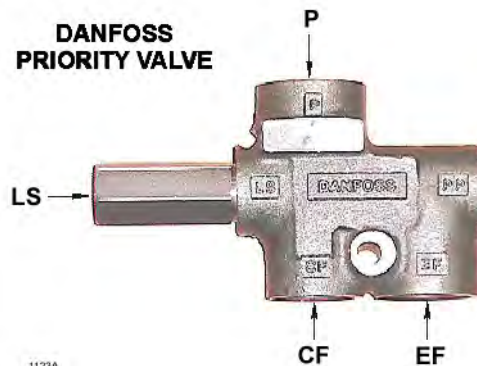

# ASSEMBLY

## DANFOSS VALVE PLUMBING (WITH MID-MOUNT VALVE)

A priority valve will be used to power the danfoss lift valve. The tractor ports used are on the selective control valve (SCV) and the Mid-Mount Valve. The SCV is located between the right arm of the three point hitch and the axle. The Mid-Mount valve is located under the right front corner of the cab. The power beyond port is located on the bottom of the Mid-Mount valve towards the front. The excessive flow port is located on the underside of the SCV. The return port is accessed through the end of a run tee located on the SCV. See the danfoss lift valve page in the parts section for hardware and location of parts. Refer to the image below as a guide.

### SCV

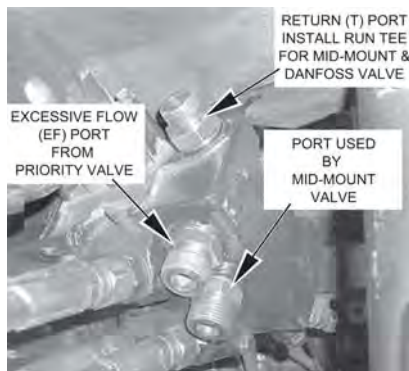

### MID-MOUNT VALVE

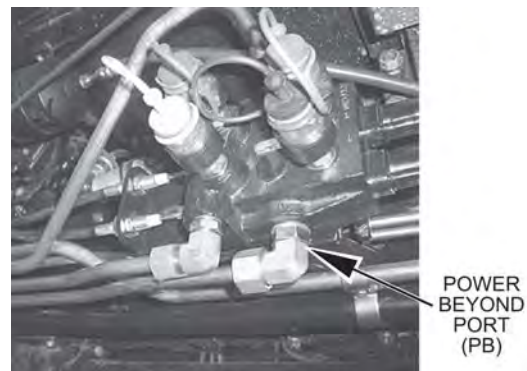

The power beyond port uses the existing adapter for the pressure hose. That hose is routed to the "P" port of the priority valve. Next the hose from the "CF" port on the valve goes to the "P" port on the danfoss lift valve. The return hose from the lift valve is connected to the closest end on the run tee of the "T" port on the selective control valve. Plumb the excessive flow hose from the "EF" port on the priority valve to the "EF" port on the SCV. Then the load sense hose goes from the "LS" port on the priority valve to the "LS" port on the lift valve. Refer to the illustration below for port call-outs on the danfoss priority valve.

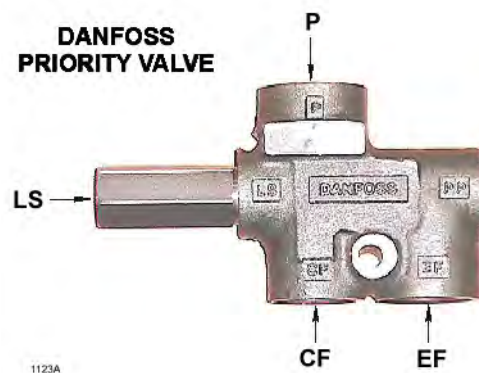

# ASSEMBLY

## HUSCO VALVE PLUMBING (SCV ONLY UNITS)

The tractor ports used are on the selective control valve (SCV). The SCV is located between the right arm of the three point hitch and the axle. The pressure port is located the closest to the axle. The excessive flow port is right next to the pressure port. And the return port is located on the adjacent face. Refer to the image below as a guide.

NOTE: To use the pressure port a 3/8 NPT pipe plug(B) must be inserted into the port(C) - (refer to the illustration below and the Parts Section). Remove the plugs covering the ports of the SCV ports. After the plug is removed, use a wrench to tighten the plug(B) securely.

### SELECTIVE CONTROL VALVE (SCV)

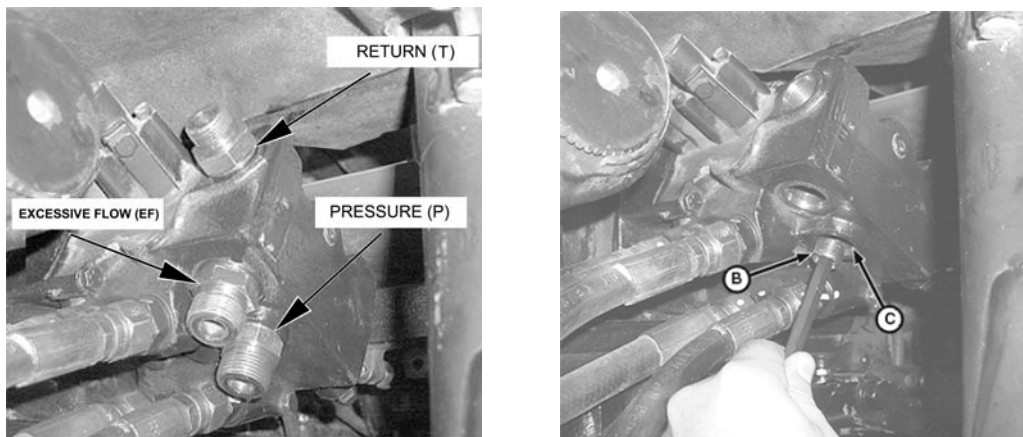

When the pressure port is active, install the adapters in their ports. The hose from the pressure port goes to the "P" port of the husco valve. Next the return hose from the lift valve goes back to the "T" port on the selective control valve. Plumb the power beyond hose from the "PB" port on the husco valve to the "EF" port on the SCV. See the parts pages for placement and the hardware used.



# ASSEMBLY

## HUSCO VALVE PLUMBING (WITH MID-MOUNT VALVE)

The tractor ports used are on the selective control valve (SCV) and the Mid-Mount valve. The SCV is located between the right arm of the three point hitch and the axle. The Mid-Mount valve is located under the right front corner of the cab. The power beyond port is located on the bottom of the Mid-Mount valve towards the front. The excessive flow port is located on the underside of the SCV. The return port is accessed through the end of a run tee located on the SCV. See the husco lift valve page in the parts section for hardware and location of parts. Refer to the image below as a guide.

### SCV

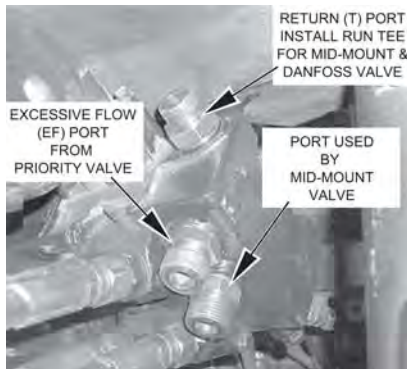

### MID-MOUNT VALVE

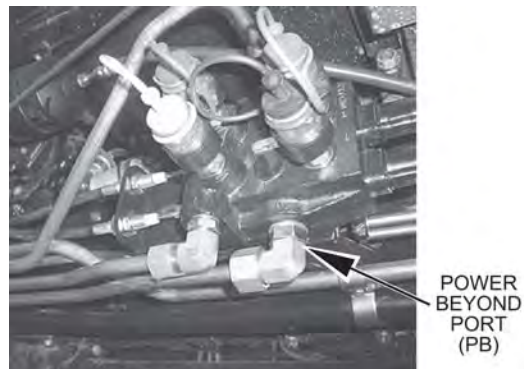

The power beyond port uses the existing adapter for the pressure hose. That hose is routed to the "P" port of the husco valve. The return hose from the lift valve is connected to the closest end on the run tee of the "T" port on the selective control valve. Plumb the power beyond hose from the "PB" port on the husco valve to the "EF" port on the SCV. Refer to the Parts Section for hardware used.

# ASSEMBLY

## CABLE CONTROL LEVER STAND (SCV ONLY UNITS)

Place the cable control bracket on the floor so that the bracket is 1-1/4" from the right corner post of the cab and the edge of the door opening. Also the outer rear corner of the bracket is 3 3/4" from the edge of the door. See image below. Be sure that the location of the stand will allow the operation of all control levers in the tractor and that the door will not strike the stand when shut. Double check under the cab for cables and wires that may be cut when drilling. And before drilling double check location of the stand for proper placement of holes. Drill 3 holes to match control bracket and secure with capscrews and nylock nuts noted in parts section.

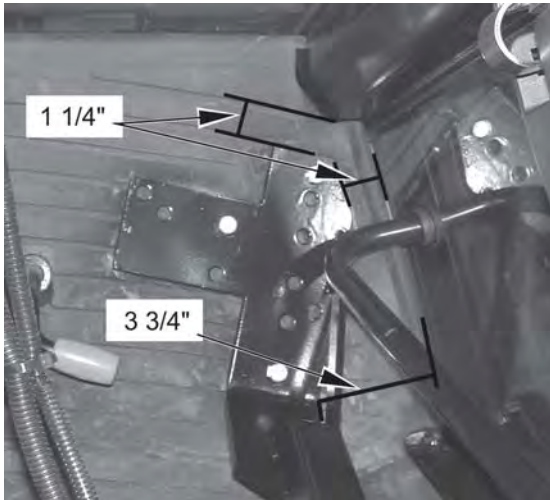

The rubber boot under the rear window can be cut in a cross hair pattern and if necessary the bottom cut through to allow it to slip over the cables and back into position. These cables will be routed to the lift valve mounted on the valve mounting plate, and should not have any sharp bends or kinks in them. Secure cables with zip ties and apply RTV sealer in and around individual cables, inside and outside of the cab for a water tight seal. Do not allow excess cable to hang unsecured on the outside of the cab.



# ASSEMBLY

## CABLE CONTROL LEVER STAND (MID-MOUNT UNITS)

Place the cable control bracket on the floor so that the bracket is 2-1/2" from the side edge of the door, and 4-3/8" in front of the rear edge of the door. See images below. Be sure that the location of the stand will allow the operation of all control levers in the tractor and that the door will not strike the stand when shut. Before drilling double check location of the stand for proper placement of holes. Make sure that all cables and wires are clear of the area before drilling holes to mount the stand. Drill 3 holes to match control bracket as shown below and secure with capscrews and nylock nuts noted in parts section.

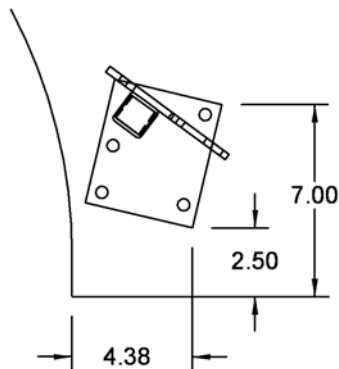

The rubber boot in the corner of the rear window can be cut in a cross hair pattern and if necessary the bottom cut through to allow it to slip over the cables and back into position. These cables will be routed to the lift valve mounted on the valve mounting plate, and should not have any sharp bends or kinks in them. Secure cables with zip ties and apply RTV sealer or similar product in and around individual cables, inside and outside of the cab for a water tight seal. Do not allow excess cable to hang unsecured on the outside of the cab.

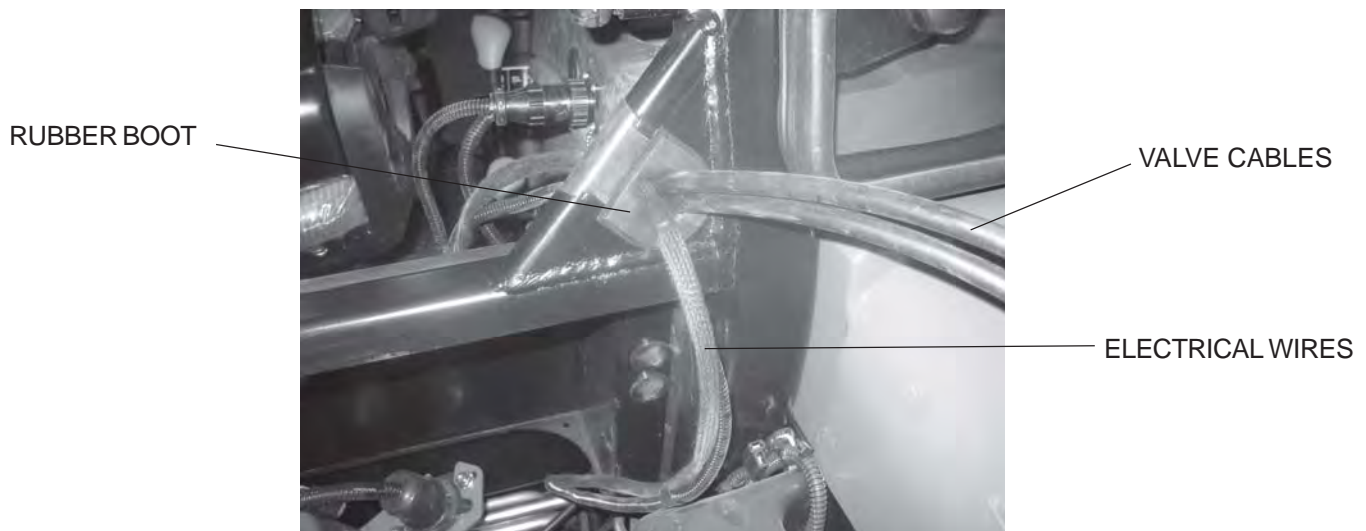

### WINDOW ROUTING

# ASSEMBLY

## HOSE AND CABLE ROUTING

Attach two clamps to the right rear wheel well for proper hose/cable routing. Drill one hole for each clamp. Use the lower rear corner of the wheel well as an origin for measuring. The holes should be 10mm or 3/8" reamed to accept 3/8" hardware.

Measure along the back edge of the wheel well 6" from the origin. Use a square to measure 2 1/2" up, from the last mark. Refer to the image below to see the first hole.

The second hole should run parallel to the bottom edge of the wheel well. Mark the hole 22" from the origin and 3 1/2" from the bottom edge. Use the images below for reference.

**NOTE: DO NOT CUT INTO TUBES / HOSES / WIRES WHEN DRILLING THROUGH METAL OR PLASTIC!**

FIRST HOLE

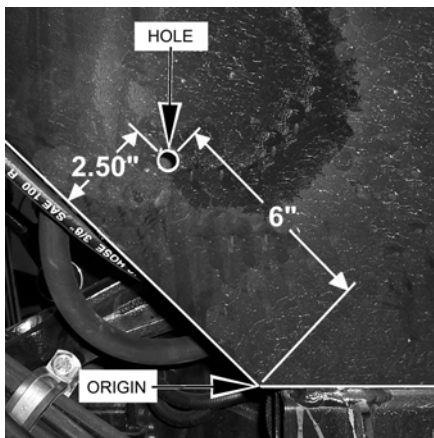

SECOND HOLE

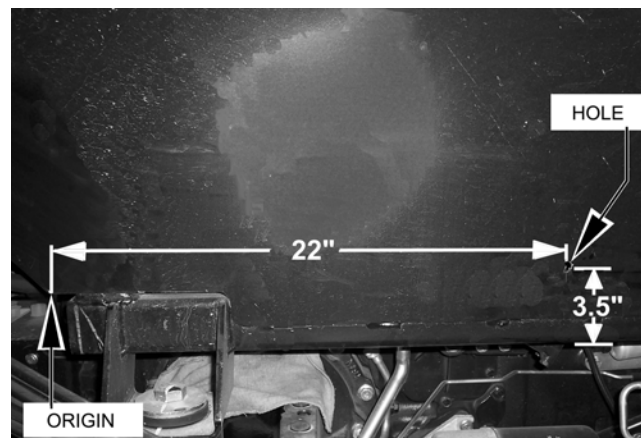

Place as many hoses in the clamp that will fit without compromising pressure. Then secure the (2) HOSE CLAMP (06520013) to the holes drilled with (1 EACH) CAPSCREW, 3/8 X 1 NC (21630) and (1 EACH) NYLOCK NUT, 3/8 NC (21627). The hoses that don't fit into the clamp are to be secured to the others with zip-ties. For protection of hoses in contact with metal edges, wrap hoses with spit hose sections and fasten with hose clamps or zip ties as needed.

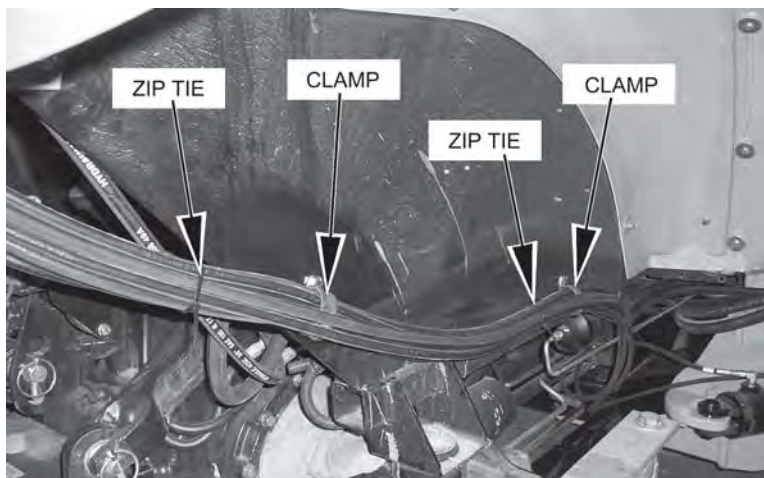



# ASSEMBLY

## BOOM HYDRAULIC DIAGRAM

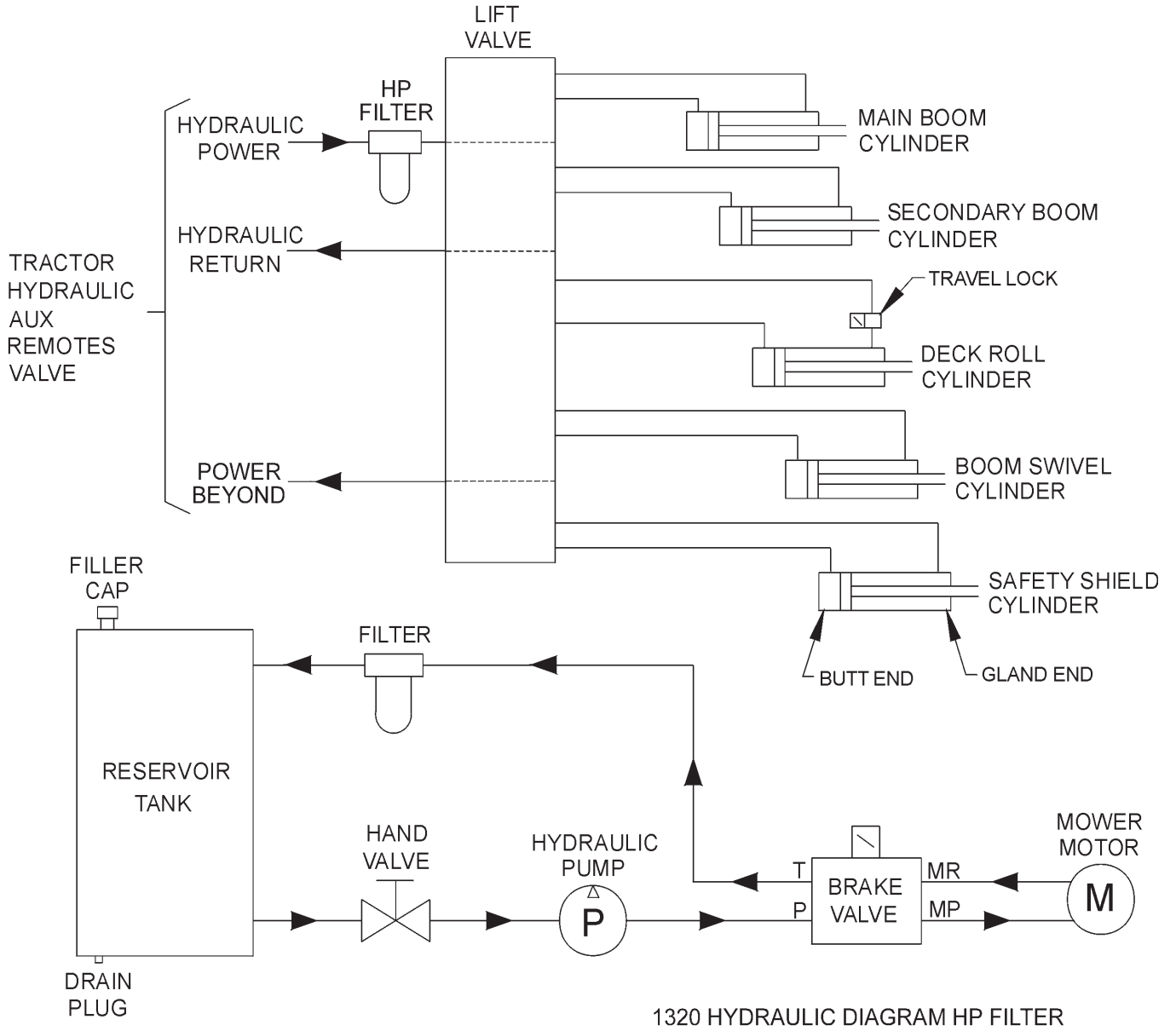

# ASSEMBLY

## CHEETAH HOSE ROUTING

**WARNING NOTE:** The sudden release of hydraulic pressure could cause the sudden movement of very heavy parts. Anyone in the way of these parts could be severely hurt or killed. DO NOT ALLOW these hydraulic hoses to BREAK or BURST in order to prevent hydraulic failure. Make sure the hoses do not pinch or stretch as boom moves. Measure TWICE, check TWICE then proceed with caution.

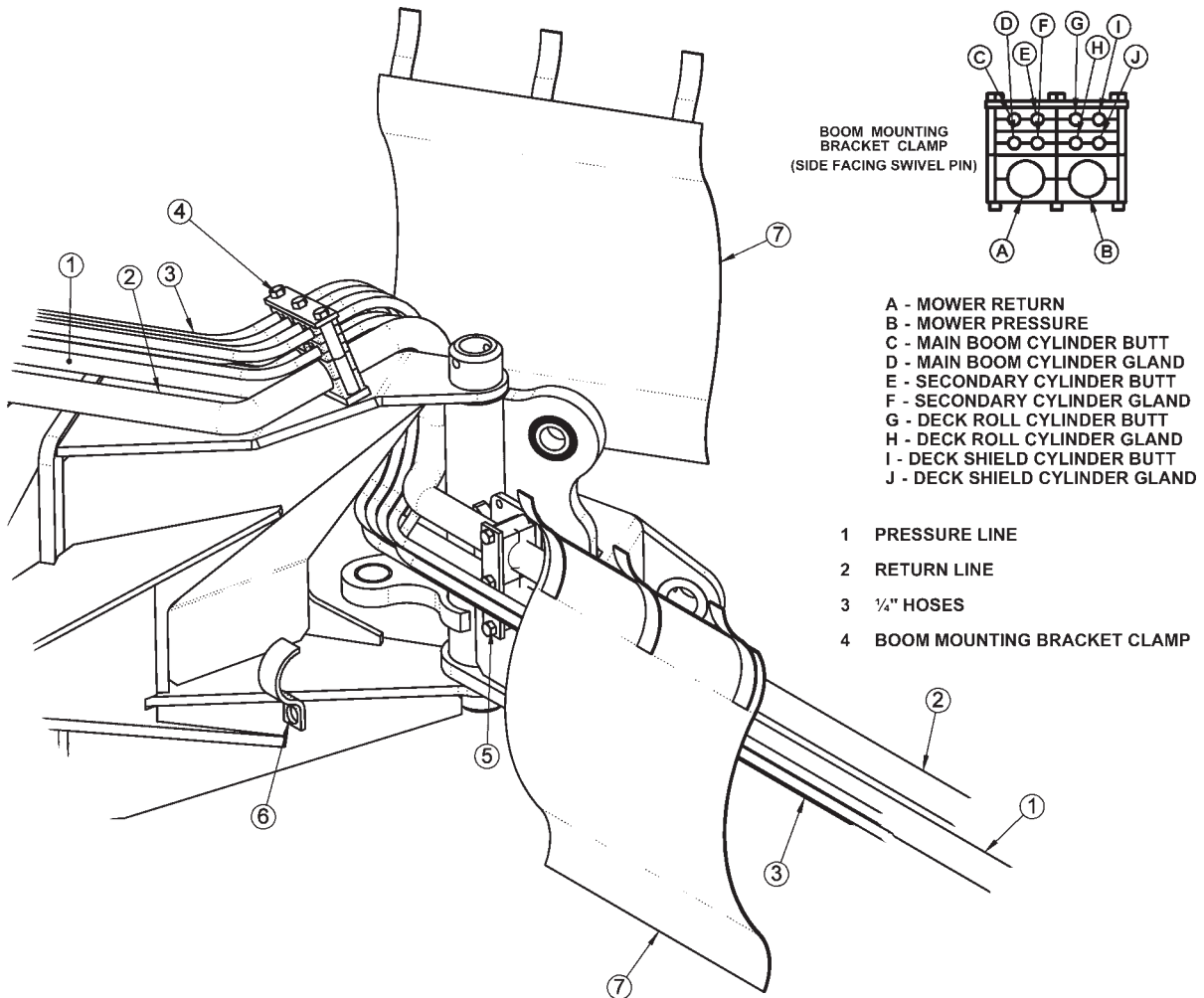

Route the hoses through the space between the swivel and the boom mounting bracket. Connect the hoses to the preformed tubes and move the boom arm to a few feet from full forward. Assemble the swivel clamp and place the return hose for the motor on top and the pressure line on the bottom. Place the 1/4" hoses in the "C" clamp and add it to the bottom screw of the swivel clamp. Next, make sure there is enough slack for all hoses to pivot at the joint where the main boom arm bends in the swivel, as shown in the next image, and tighten the hoses in the clamp.

## ASSEMBLY

**BEFORE TIGHTENING HOSES IN CLAMP, MAKE SURE HOSES CAN PASS THROUGH CENTER POINT OF BOOM PIN. THIS WILL ENSURE PROPER HOSE LENGTH FOR ALL BOOM POSITIONS.**

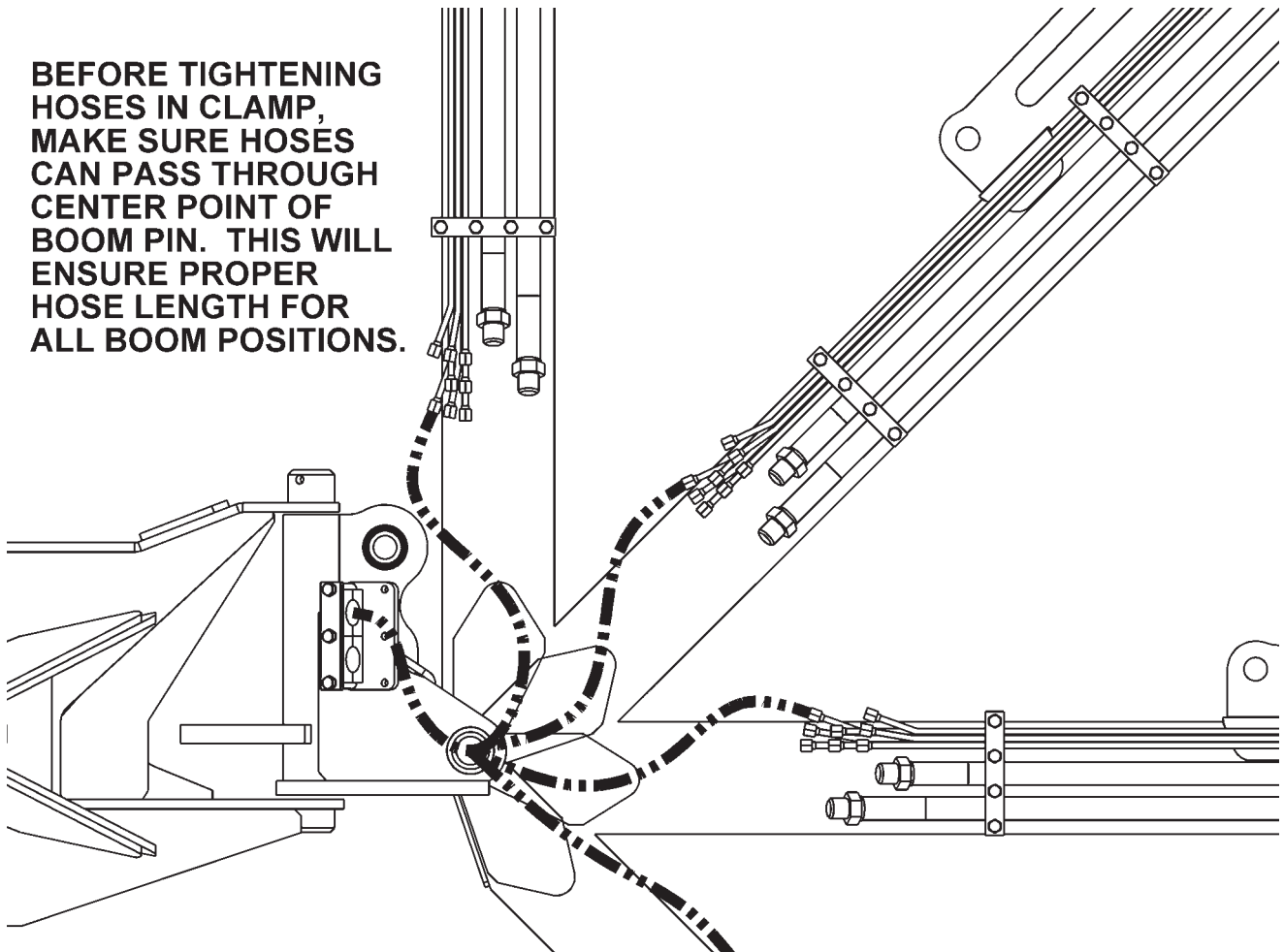

Arrange the hoses in the clamp that attaches to the boom mounting bracket as shown above, with the 1" motor hoses closest to the bracket and the return hose closest to the boom arm. Pull the hoses snug from the swivel to the mounting bracket clamps, when main boom is still forward, and tighten the hoses in the clamp.

Make sure the 1" motor hoses do not kink as the boom arm is moved into the stowing position. If this happens the motor hoses will have to be shortened, because there is too much hose between clamps.

# ASSEMBLY

## HYDRAULIC TANK INSTALLATION

Attach the tank mount to the main frame with the hardware shown in the parts section.

Install all fittings and tubes into tank and tank filter as shown in parts section illustration. Insert tank sight glass into front side of the tank. Install the temperature sensor (optional) or pipe plug into the side of the tank.

Place the tank in the mounting bracket on the main frame as shown in the parts section. Secure the tank in the mounting bracket with the tank strap and nylock nuts.

Install the filter gauge into the filter housing so that it points to the rear of the tractor and is clearly visible to the operator. The breather cap will be installed after tank is filled.

## GENERAL HOSE INSTALLATION

Refer to the parts section for detailed information about hoses and fittings for this application.

When mounting the suction hose between the pump and the tank, the stainless steel bands that are provided must be used. **CAUTION: DO NOT** use regular hose clamps for this purpose.

For protection of hoses in contact with metal edges, wrap hoses with spit hose sections and fasten with hose clamps or zip ties as needed.

## SWIVEL BRACKET MOUNTING

Install the boom swivel bracket onto the boom mounting bracket with the swivel pin. Secure the pin in place using the capscrews, etc. through the hole in the boss and pin. **NOTE:** The head of the capscrew must be toward the front of the tractor.

Install all new swivels and fittings on the swing cylinder with swivel openings facing each other. Fittings will vary in type and direction depending on your application, refer to your parts section for more detail.

Install bushings (with split facing the direction of the grease zerk hole) in the main frame anchor for the swing cylinder. This may already be done for you.

Install the swing cylinder between the main frame cylinder anchor and the boom swivel bracket with the clevis pins. Insert roll pins through the top hole in the clevis pins, and secure the bottom of the pins with the hairpin clips.

Now the hoses can be attached from the control valve to the swing cylinder





# ASSEMBLY

## PREFORMED TUBE INSTALLATION

Place the booms on the floor so that side with weldnuts is upward. If mounting a ditcher head, only the main boom tube installation is required. Locate all tube clamps and install them loosely in the welded nuts on the left side of the booms.

Arrange the tubes and hoses as outlined in the parts section diagram. Install the smaller tube closest to the boom arm, being careful not to pinch the tubes. Place the large tubes outside of the small tubes. Snug all clamp bolts, but do not tighten. Check all tubes for correct alignment and that none are pinched or bent. The clamp bolts can now be tightened.

## BOOM INSTALLATION

Install the boom swivel into the main frame as shown in the parts section using a hoist. Line up holes in swivel and main frame for large swivel pin and insert pin. Secure with hardware as shown.

Attach the inner end of the main boom to the boom swivel using pins and hardware as shown. Be sure that the bearings are properly installed as shown in the boom parts section.

Install main boom cylinder on the main boom with the fittings facing towards the rear of the tractor. Attach the butt end to the main boom cylinder to the swivel bracket anchor with cylinder pin and hardware shown in parts section. Attach the piston clevis to the main boom with the cylinder pin and hardware. Install all fittings into the cylinders and hoses as shown in the boom and lift valve parts sections.

**NOTE: Be sure to use teflon tape on all pipe fittings (except O-rings).**

## DECK ATTACHMENT

Attach the head to the secondary boom using the pins and hardware shown in the parts section to attach linkages. Install the square tube on the top of the head into the head mount and secure using the mounting plate and hardware as shown. The mount should be positioned to the left side of the cutter head. Install the deck pivot cylinder using the pins and hardware also shown in the parts section.

Connect the fittings and hoses from the pivot cylinder to the small preformed tubes on the boom arm. Connect the fittings and hoses from the motor to the large preformed tubes on the boom arm.

Connect all remaining hoses from the control valve to the cylinders and / or preformed tubes on the boom arm. Refer to parts section for diagrams.

**Before proceeding to the final preparation step double check the complete assembly from the main frame to the cutter head against the diagrams in the parts section for proper placement and assembly of all components.**

## HOSE COVERING

Secure hoses together with zip ties wherever loose. Wrap the hoses between the main boom and secondary boom with the yellow hose cover, secure with black string provided. Where hoses may contact the frame or other edges, wrap with split hose and secure with hose clamps or zip ties. On non cab units the pressure and return hoses from the control valve will also need to be routed inside the protective clear hose wrap. Cover the valve, valve fittings with the yellow hose cover and secure with black string provided.

# ASSEMBLY

## INSTALLING O-RING FITTINGS

Installing straight, 45 degree and 90 degree O-ring fittings requires that the O-ring, washer and nut (A) be up against the swivel body (B). Insert the swivel and turn in until the swivel is pointed in the right direction and O-ring contact is made. Hold swivel in set direction with a wrench and turn the O-ring nut away from the swivel body and carefully tighten.

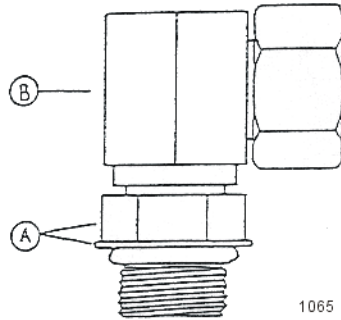

## INSTALLING NATIONAL PIPE FITTINGS

Whenever installing a pipe fitting, wrap the threads clockwise (looking at the end) with teflon tape. In this way, the tape will be tightened when installed. NOTE: It is not necessary to tape O-ring fittings, or those installed in swivels.

## ACCUMULATOR INSTALLATION / PLUMBING

Install the accumulator bracket on tab with holes provided on the right main frame with the capscrews and lockwashers shown. Install the accumulator in the bracket and secure with the hardware shown. Install fittings and hoses to the cylinder and control valve as shown in the parts section. **Use teflon tape on all pipe fittings (except O-rings).**

## WHEEL WEIGHT MOUNTING

For all machines using a boom mower, a wheel weight will be required for the left side wheel. It will be necessary to mount the 500 pound wheel weight in the wheel using the long cap-screws, lock-washers, flat-washers, and hex nuts per diagram in the parts section.

Installation is most easily done with a small fork lift, inserting a fork in the center slot of the wheel weight. The head of the cap-screws is to be toward the OUTSIDE of the weight, with flat-washers on both inside and outside of the assembly.

The left rear tire must also be filled with a mixture of water and calcium chloride at about five pound per gallon. Tire air pressure should be maintained at approximately 22 P.S.I.

# ASSEMBLY

## BOOM JOYSTICK CONTROL CALIBRATION

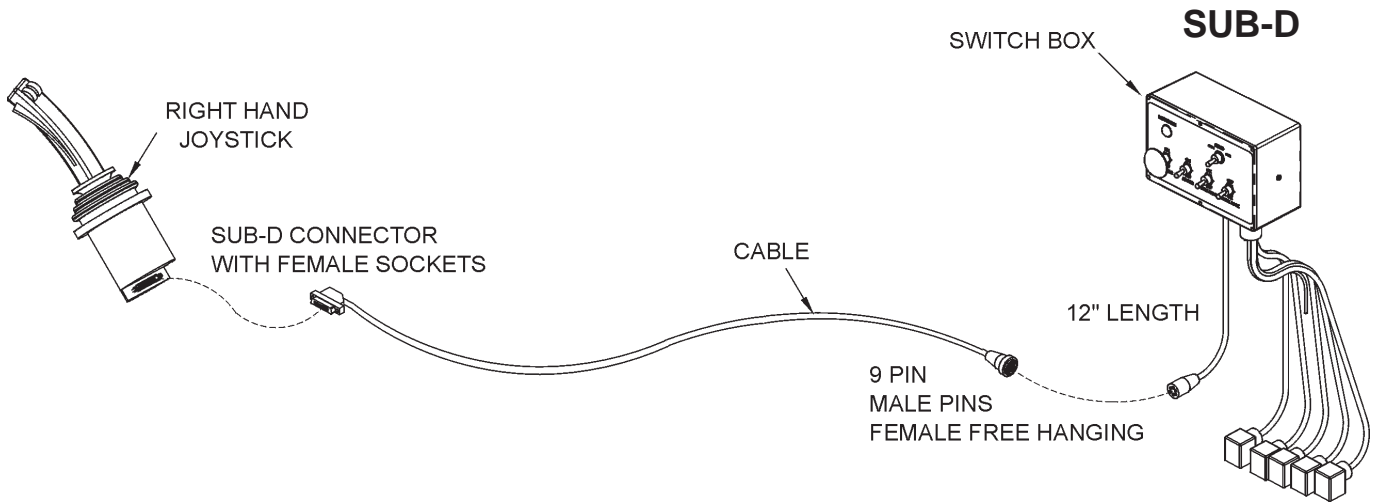

This Danfoss PVG32 control valve is now equipped with higher-resolution actuators on Main Boom, Secondary Boom, Deck Roll, and Swivel functions. These actuators have “active fault monitoring”. The Deck Shield section does not have “active fault monitoring”. The joystick is unchanged and provides a ratio-metric voltage signal. The neutral signal voltage is half or 50% of tractor supply voltage. A 25% signal voltage will shift the valve spool to full “A-Port”, and 75% signal voltage will shift the spool to full “B-Port” in the Main, Secondary, and Swivel valve sections. On the Deck Roll function a 34% signal voltage will shift the valve spool to full “A-Port” and a 68% signal voltage will shift the spool to full “B-port”. If an actuator with active fault monitoring receives a signal from the joystick that is less than 15% or greater than 85% of supply voltage the actuator will “fault out” and shut down. Also if there is an internal failure in the actuator or if the spool position is greater than that specified by the signal voltage from the joystick, the actuator will “fault out” and shut down. An “active fault” condition causes the actuator to drive the spool to neutral, shut down, and activate a “red” LED on the top of the actuator. The active fault can be canceled by simply cycling the Master Switch “OFF” and then “ON”, which resets the fault monitoring, and causes the LED on top of the actuator be “green” again.

### CAUTION!



The joystick control is equipped with signal adaption potentiometers.

These provide the capability to individually adjust the oil flow to each boom function. It is important that the boom functions do not travel too fast. Excessive boom speed can reduce the stability of the unit and decrease operator control.

Note: Use a Phillips screw driver and be sure to adjust the screws carefully! DO NOT turn the potentiometers beyond their stopping point, potentiometers are very delicate! Turning the “A” or “B” port potentiometers clockwise increases the oil flow to increase the boom function speed, and turning them counterclockwise decreases the oil flow to decrease the boom function speed. See the graphic on the next few pages for help in adjusting.

# ASSEMBLY

Run tractor at normal operating RPM to adjust the settings as follows.

## **Set the dead band compensation potentiometer first.**

Set the dead band compensation potentiometer at 50%, or halfway between full clockwise and full counter-clockwise.

## **Setting Signal Adaptation Potentiometers:**

Disconnect the Deutsch connectors from the actuators of the valve. Use a Volt/Ohm meter to measure signal voltage and adjust the signal adaptation potentiometers as needed. Pin #4 is tractor supply voltage. Pin #1 is signal voltage from the joystick, and pin #3 is ground. First measure supply voltage between pins 4 and 3. Then measure signal voltage between pins 1 and 3 while indexing the joystick function fully in both the "A" and "B" port direction. Divide the signal voltage by the supply voltage to get signal voltage as a % of supply voltage. This percentage should not be less than 25% or greater than 75% for the Main Boom, Secondary Boom, or Swivel function. This percentage should not be less than 30% or greater than 62% for the Deck Roll function. Note these initial settings for the Deck Roll function should prevent the spool from shifting into float. *After making this first adjustment to deck roll if the spool still goes into float, adjust the "B" port screw additionally counterclockwise.*

Reconnect Deutsch connectors on control cables to actuators on Danfoss valve. Run tractor until hydraulic system is at operating temperature. Now refine the adjustments of the signal adaptation potentiometers for both "A" and "B" ports for all proportional functions to achieve the following function times. Note: turning potentiometer clockwise increases the flow or the function speed, and turning them counter-clockwise decreases the flow or the function speed. Note, if during this procedure the trim potentiometer is set to full "counterclockwise" but the function is still too fast, use the mechanical stops at the manual actuator end of the valve section to further limit flow. Turn limit screw in or clockwise to limit flow. The upper limit screw limits flow to "B-port", and the lower limit screw limits flow to "A-port". However DO NOT adjust the limit screw on "B-port" of deck roll function. Limiting "B-port" will prevent "float" function.



# ASSEMBLY

**MAIN BOOM:** “A” Port, Boom UP: 7-9 Seconds

*(Note: Extend secondary boom completely; roll deck to be level with ground, and lower main boom until deck is on ground. Now index main boom “up” function and determine the time required for main boom to rise completely.)*

“B” Port, Boom Down: 6-8 Seconds

*(Note: Extend secondary boom completely, roll deck to be level with ground, and raise the main boom to “full up”. Then index the main boom “down” function to determine the amount of time required for the deck to contact the ground. CAUTION: Stop the boom just as the deck contacts the ground.)*

**SECONDARY**

**BOOM:** “A” Port, Boom Out: 7-9 Seconds

*(Position main boom full up, roll deck out until deck cylinder is fully retracted, and bring secondary boom in completely. Then index the secondary boom “out” function and determine the time required for boom to extend out completely.)*

“B” Port, Boom In: 7-9 Seconds

*(Position the main boom full up, roll deck out until deck cylinder is fully retracted, and extend secondary boom completely. Then index the secondary boom “in” function and determine the time required for boom to come in.)*

**DECK ROLL:** “A” Port, Deck Out: 5-6 Seconds

*(Raise main boom to vertical, extend secondary boom out slightly so that deck can be articulated without contacting the main boom, and roll deck in until deck cylinder is completely extended. Then index the deck roll “out” function and determine the time required for the deck to roll out.)*

“B” Port, Deck In: Target 5-6 Seconds (but DO NOT use Limit Screw)

*(Raise main boom to vertical, extend secondary boom out slightly so that deck can be articulated without contacting the main boom, and roll deck out until deck cylinder is completely retracted. Then index the deck roll “in” function and determine the time required for the deck to roll in.)*

**BOOM**

**SWIVEL:** “A” Port, Boom Forward: 7-9 Seconds

*(Extend booms completely; rotate head to be level with ground, lower main boom until deck is just above ground, and swivel boom aft and until near tire. Then index the boom swivel “forward” function and determine the time required for the boom to swivel full forward.)*

“B” Port, Boom Aft: 7-9 Seconds

*(Extend booms completely; rotate head to be level with ground, lower main boom until deck is just above ground, and swivel boom full forward. Then index the boom swivel “aft” function and determine the time required for the boom to swivel aft. Use caution when doing this, stop boom before main boom contacts tire.)*

# ASSEMBLY

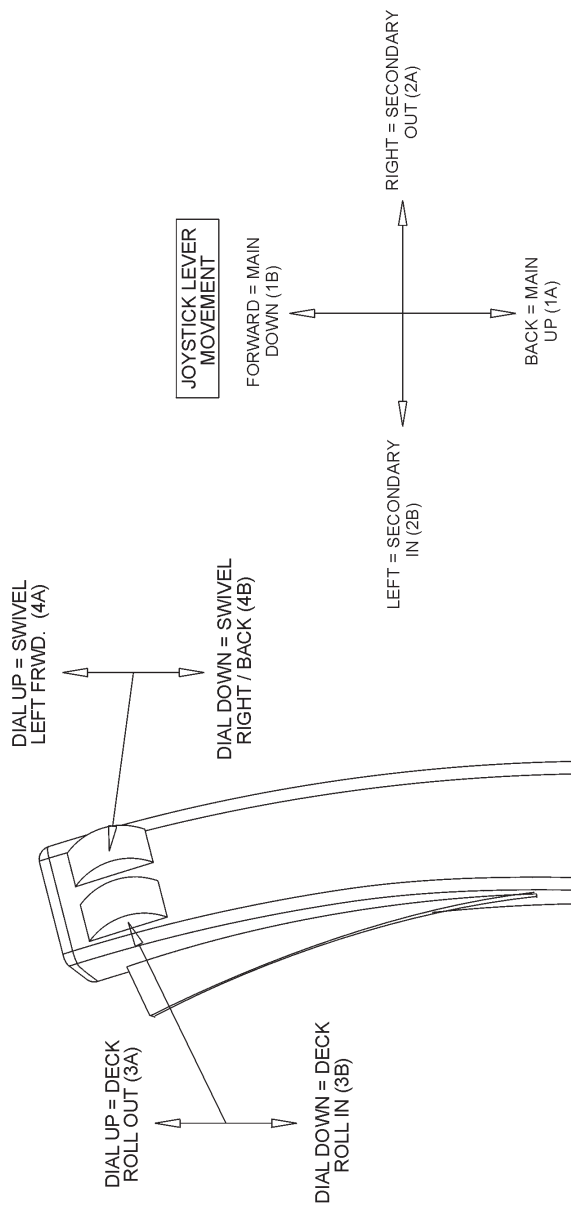
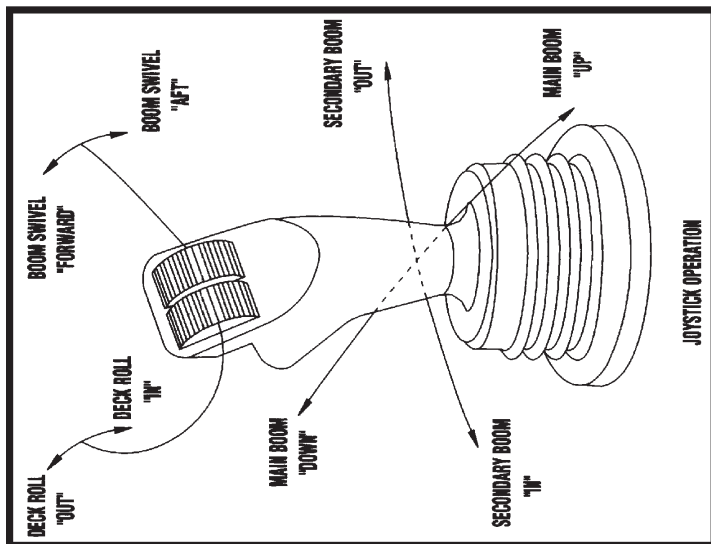

**SIGNAL ADAPTION POTENTIOMETERS**

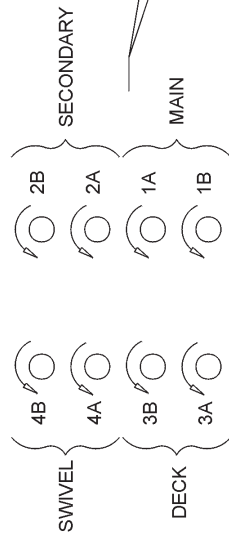

**SIGNAL INVERSION SWITCHES**

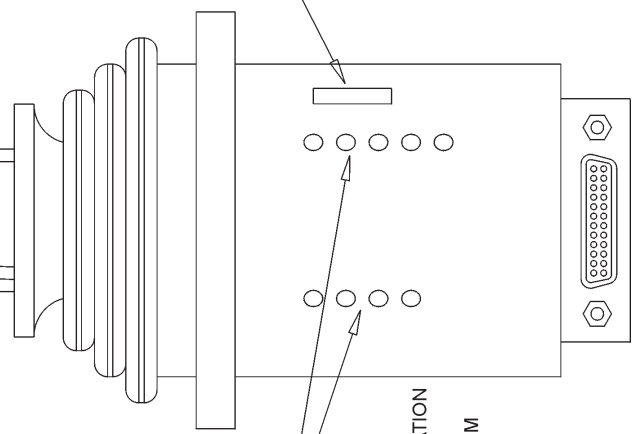
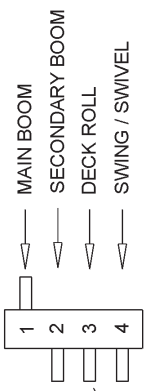

○ — DEAD BAND COMPENSATION

NOTE: FULL C-CLOCKWISE RESULTS IN MAXIMUM "DEAD BAND"

ARROW DIRECTION ( ) DENOTES DIRECTION TO DECREASE OIL FLOW (SLOW BOOM FUNCTIONS)

1132  
RH SUB-D CHEETAH



# ASSEMBLY

## FINAL PREPARATION FOR OPERATION

Place operators safety and operation decals on the steering column and side console where they are clearly visible to the operator. These decals should be understood by each operator of the machine in conjunction with the safety and operation section of this book. The decals are to remain in good condition as a reminder to the operator, and should be replaced if damaged.

Finally, all bosses, pins and pivot points will need to be greased as instructed in the maintenance section of this manual. The hydraulic reservoir can also be filled with the recommended fluid (see maintenance section) and the filter installed in the top of the tank. Double check all fittings and fasteners **BEFORE** starting tractor. Also secure any loose hoses together with zip ties and wrap with split hoses where friction may occur on the hoses.

### WARNING!



**BEFORE** starting or operating the tractor you must read and understand the safety and operation sections of this manual completely.

**BE SURE THE BALL VALVES ARE OPEN!** Start tractor and allow instruments to stabilize. Using a piece of paper or cardboard as noted in the safety and maintenance sections, check all fittings and connections for hydraulic leaks.

If a leak is found, you must shut down the tractor, set the cutter on the ground. Before attempting to fix the leak, you must actuate the lift valve handles several times to relieve any pressure in the lines.

**Before operating the mower**, the cutter head and boom should be slowly moved throughout the full range of motion. Watch for any condition that would cause pinching or excess stress on the hoses. The steering and front axle travel should also be carefully moved through their full range of motion. If any condition occurs in which the hoses contact the tires, the steering and / or front axle travel may need to be limited as described in the tractor operators manual. This should also be done if the tires rub, or are extremely close to any other part of the mower such as the hydraulic tank or draft beam. This may include adding shims, or adjusting stop bolts in the tractor front to solve the problem. While checking motion, you should also check that the control circuits are connected according to the operators decal for the valve handles.

## MOWER TESTING

Take the tractor to a place free of loose objects on the ground. Operate the cylinders through their full range of motion again, to clear the lines of air. Follow the instructions in the operation section to operate the mower. Vibration of the mower should be minimal at all times. After a 5 minute test run, the knife bolts should be retorqued and once again after the first few hours of operation.

**If any parts of this assembly section, or any other section of this manual are not clearly understood you must contact your dealer or the address on the front of this manual for assistance!**

# ASSEMBLY

## 4WD FRONT TIRE ADJUSTMENT

In order to prevent interference with mounted equipment, the front wheels on a 4WD 5101E tractor will have to be adjusted to approximately 64" center to center distance as shown below. Please refer to your John Deere Maintenance Manual to see the correct rim and tire configuration to achieve this. Double check the wheel spacing after adjustment by oscillating and turning the tires fully to check for any interference.

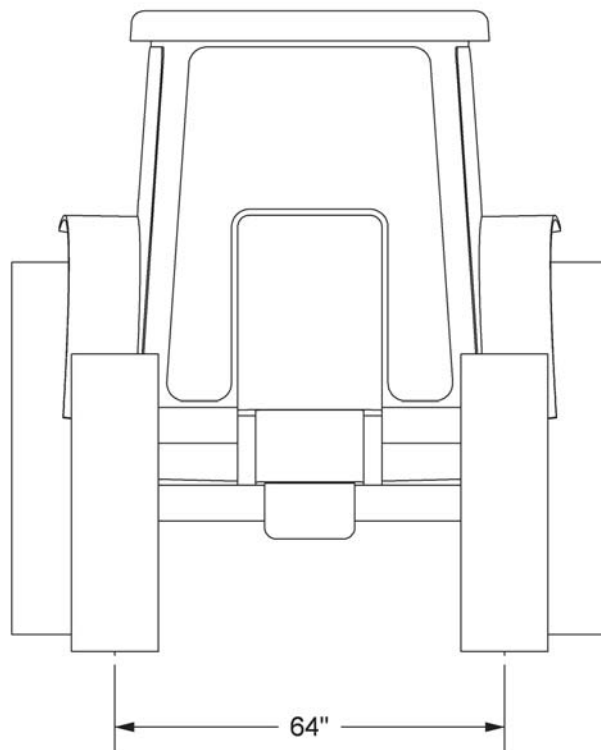



**OPERATION**

**OPERATION  
SECTION**

# OPERATION

**Safety** is of primary importance to the owner / operator and to the manufacturer. The first section of this manual includes a list of **Safety Messages**, that, if followed, will help protect the operator and bystanders from injury or death. Many of the messages will be repeated throughout the manual. **The owner / operator / dealer should know these Safety Messages before assembly and be aware of the hazards of operating this mower during assembly, use, and maintenance of this equipment.**

The **Safety Alert Symbol** combined with a signal word, as seen below, is intended to warn the owner / operator of impending hazards and the degree of injury possible during operation.

DANGER!



Indicates an imminently hazardous situation that, if not avoided, **WILL** result in DEATH OR VERY SERIOUS INJURY.

WARNING!



Indicates an imminently hazardous situation that, if not avoided, **COULD** result in DEATH OR SERIOUS INJURY.

CAUTION!



Indicates an imminently hazardous situation that, if not avoided, **MAY** result in MINOR INJURY.

**IMPORTANT!**

Identifies special instructions or procedures that, if not strictly observed, could result in damage to, or destruction of the machine, attachments or the environment.

**NOTE:** *Identifies points of particular interest for more efficient or convenient operation or repair.* (SG-1)

CAUTION!



**Before any operation of tractor and mower**, the user should read and understand the safety and operating instructions for both the tractor and the mower. The user should also be familiar with the location and functions of the units instruments and controls. Being familiar with the machine and it's controls will increase efficiency and reduce possibility of serious injury or damage to the unit. The operator should work slowly and carefully until he feels comfortable with the machine. Speed and skill will be attained much easier if the necessary time is spent to familiarize yourself with the machine and its operations.

Since tractor makes and models vary, we recommend reading and following the operators manual provided by the manufacturer pertaining to the safe operation of your particular unit.

# OPERATION

Note that the travel lock feature is not used on the Cheetah boom mower, and the deck float feature should not be used with a rotary mower deck. The travel lock switch should remain in the “off” position at all times. Before operating the mower for the first time, confirm that the red travel lock wire from the far right terminal on the switch box has been capped, is not hooked to any other wires and has been left inside the cab.



## STARTING TRACTOR AND MOWER



Check the operators manual received from the tractor manufacturer, for their recommendation and procedures pertaining to your particular make and model.

### WARNING!



When rotating parts are in motion, serious injury may occur if caution is not used or danger is not recognized. Never allow bystanders within **100 yards** of the machine when mower is in operation.



Be sure the ball valves on the mower hydraulic tank are **OPEN** before starting the tractor. Serious damage to the hydraulic system can occur if the valves are not open.

### WARNING!



Check to make sure mower switch is in the “**OFF**” position. The unit is designed not to start if the switch is in the “on” position. If tractor starts with switch on, turn off tractor and contact your local Tiger dealership for assistance.

Start the tractor and allow the instruments to stabilize. Without starting the mower, practice positioning the boom and deck. Remember, speed and skill will be attained easier if the necessary time is spent familiarizing yourself with the machine and its operations. When you feel comfortable at controlling the position of the mower, return the mower to the travel position, and transport the mower to the desired mowing location.

If mowing for the first time with a Tiger Boom Mower, we recommend choosing a ditch or area relatively flat with a minimum of sign posts, guard rails, etc. As always, you should inspect the area for other objects that can cause potential hazards.

# OPERATION

## JOYSTICK CONTROL SWITCH BOX

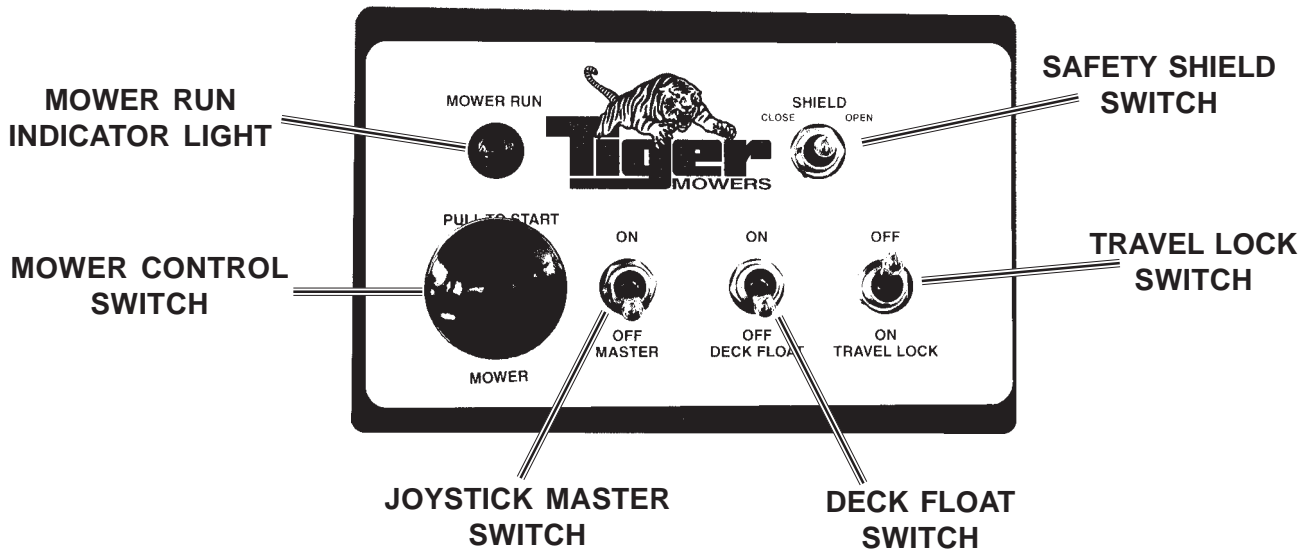

The Mower Control switch turns the mower "ON" and "OFF". This switch is to be in the "OFF" position to start the tractor. If the switch is "ON" and the tractor ignition switch is turned to "ON" the red "mower run" indicator light will come on. However, the tractor will not start with the Mower Control switch in the "ON" position. Upon starting tractor the "mower run" indicator light may flash briefly, and may flash briefly again when tractor is shut down.

### WARNING!



If tractor starts with switch on, turn off tractor and contact your local Tiger dealership for assistance.

### WARNING!



NOTE: **DO NOT** operate mower head while boom mower is in the boom rest! Red "Mower Run" light indicates mower is "ON" when tractor engine is running.

The boom functions are controlled by an electronic joystick. The Joystick Master Switch enables the joystick control for controlling the boom motion functions. This switch is to be in the "OFF" position to start the tractor and when boom is stowed for transporting the machine. The tractor will not start with the switch in the "on" position.

### CAUTION!



If the joystick control is not operating properly, turn the master switch to the "OFF" position. Install the manual valve handle onto valve and operate the functions individually to stow boom. After boom is stowed in rest, transport the unit to the maintenance facility and contact your Tiger dealer for assistance.

### CAUTION!



**DO NOT** attempt to operate the valve manually for mowing operations!

# OPERATION

Note: Pushing manual valve handles “out” or “away” from the tractor cab will bring the main boom “up”, secondary boom “out”, roll deck “out”, and swivel boom “aft”. Pulling manual handles toward cab will let main boom “down”, bring secondary boom “in”, roll deck “in”, swivel boom “forward”, and close the safety shield.

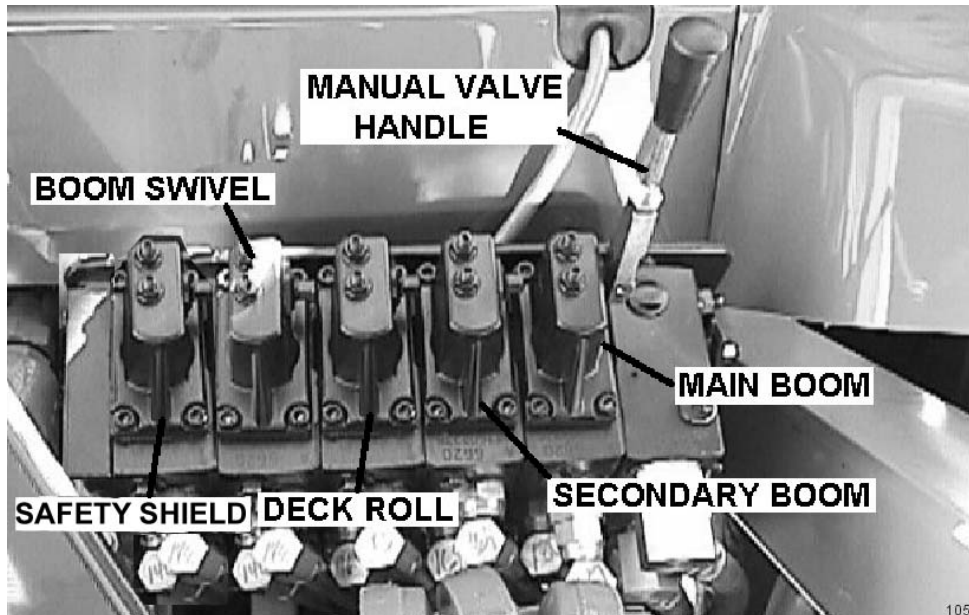

The Safety Shield switch opens and closes the shield located on the front of the cutter head. When mowing at or near the ground, always have the shield in the closed position. When mowing in brush or in trees above ground level the shield may be opened for easier cutting. Read and follow the warnings on the decal shown below. **Do not run the cutter head into material larger than 6” diameter.**



## SAFETY SHIELD OPERATION

- Failure to close Safety Shield may allow objects to be thrown outward with great force which can cause property damage, bodily injury, or death.
1. Keep Safety Shield fully closed when cutting grass and weeds to reduce possibility of objects being thrown outward by the Blades and to prevent contact with the Blades if persons are in the area.
  2. Before cutting brush, trimming limbs, or other such operations, raise Safety Shield fully to allow the blades to contact the material if area is clear of passersby. Operator must stop cutting and close shield if passerby enters the thrown objects area or blade contact area.
  3. Repair or replace Safety Shield as needed.
  4. Always transport with Safety Shield closed.

# OPERATION

## JOYSTICK CONTROL

The diagrams below and on page 3-6 show the functions that are performed through the use of the joystick controller.

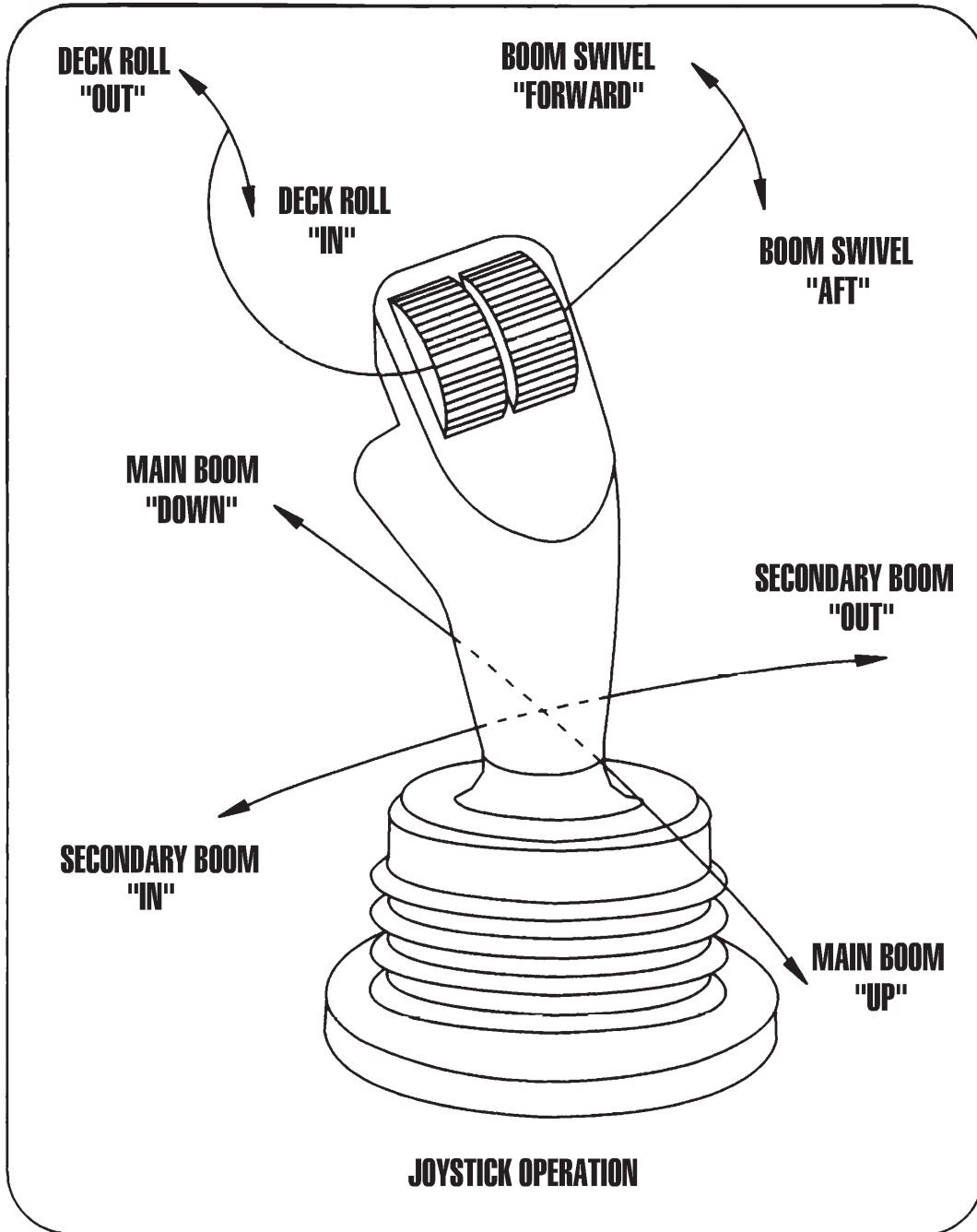

1057



# OPERATION

**JOYSTICK FWD / BACK  
MOVES MAIN BOOM**

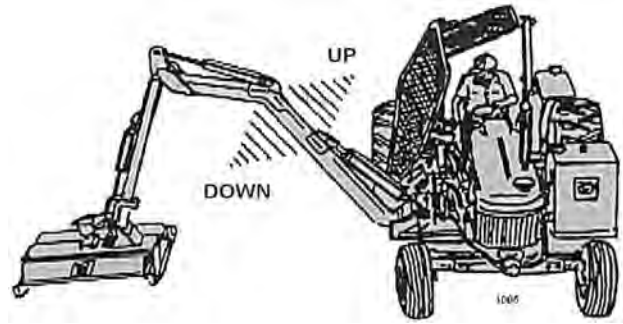

**JOYSTICK LEFT / RIGHT  
MOVES SECONDARY BOOM**

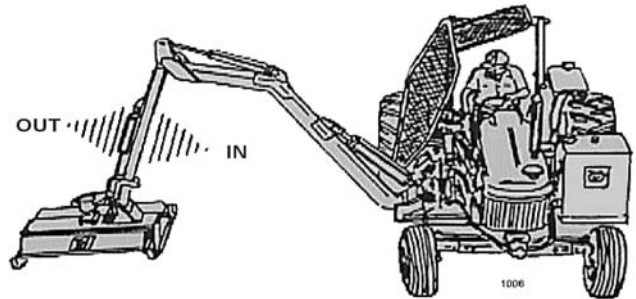

**LEFT JOYSTICK ROLLER  
MOVES DECK ROLL**

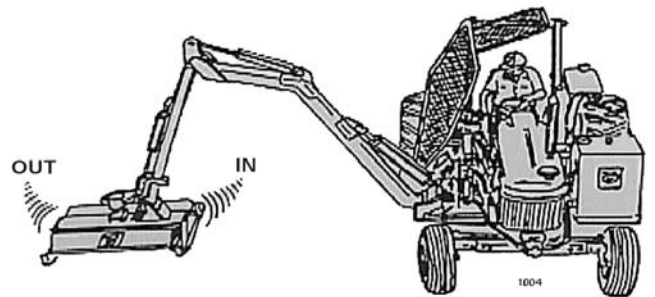

**RIGHT JOYSTICK ROLLER  
MOVES BOOM SWIVEL**

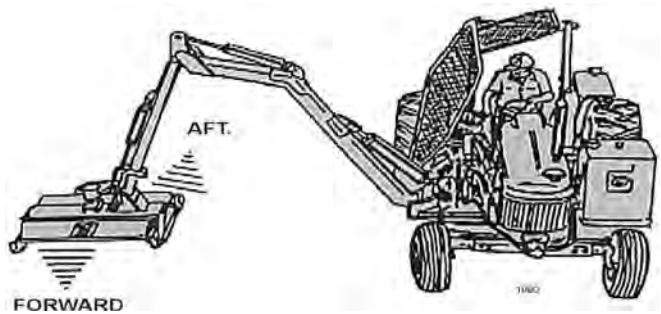

**SHIELD SWITCH  
(ON SWITCH BOX)  
OPERATES SAFETY  
SHIELD**

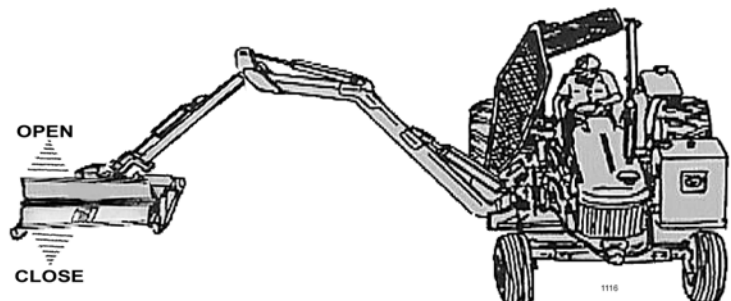

# OPERATION

## LEVER CONTROL AND FUNCTIONS

A control lever decal similar to the one shown below should be near the control valve to remind the operator of the lever functions

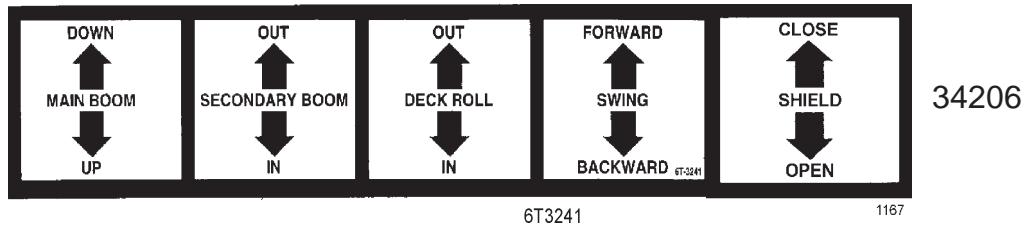

The main control valve on the Tiger Boom Mower has four sections with tapered spools, located near the right side of the steering wheel. The malfunction of a section of the valve does not necessitate the replacement of the entire “bank”, only the faulty section. Each section of the valve controls a certain position of the boom or deck. Seated in the operators seat, the controls from left to right are as follows: #1 -- main boom, #2 -- secondary boom, #3 -- deck roll, #4 -- boom swing and #5 -- safety shield.

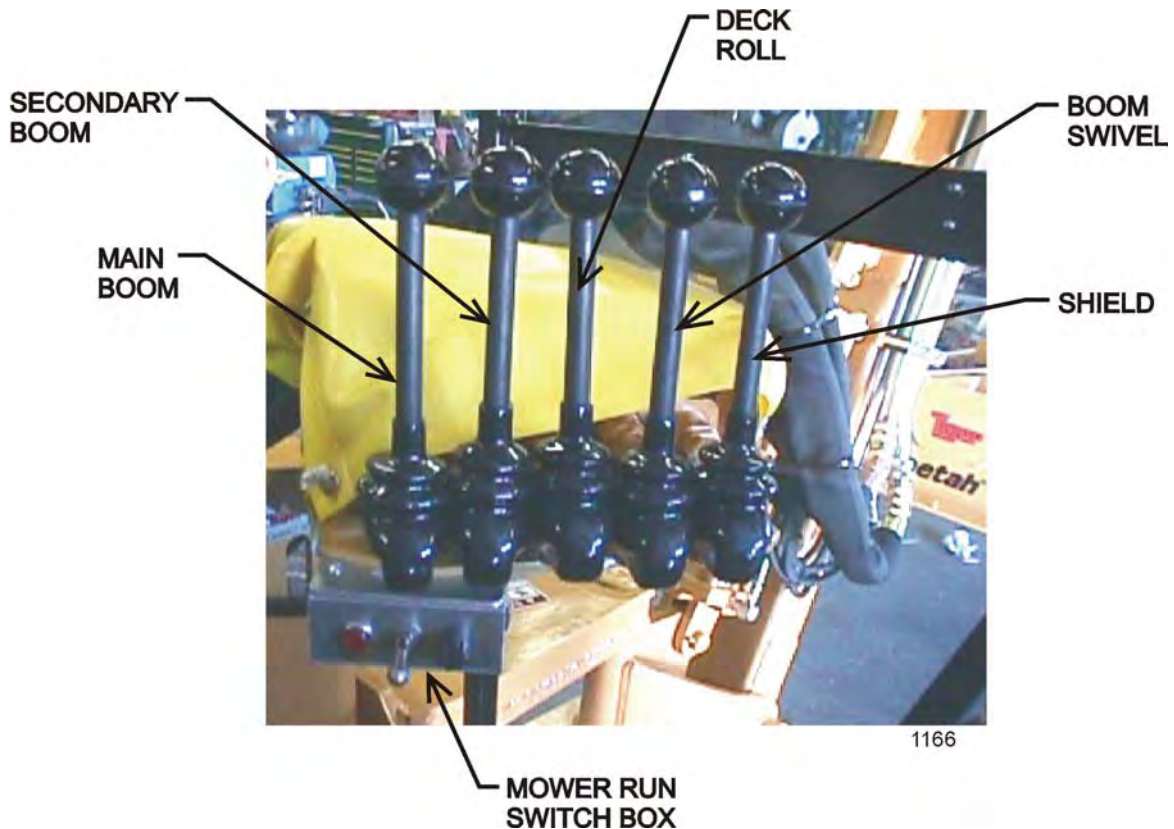



# OPERATION

**LEVER #1  
MOVES MAIN BOOM**

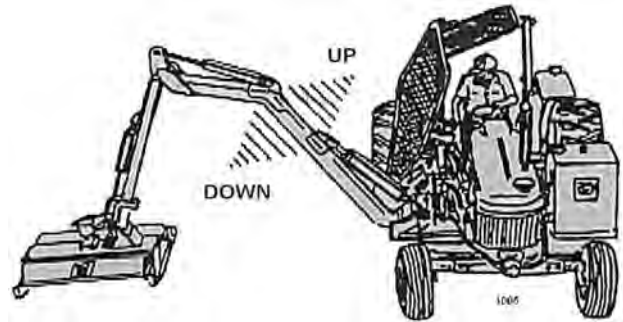

**LEVER #2  
MOVES SECONDARY BOOM**

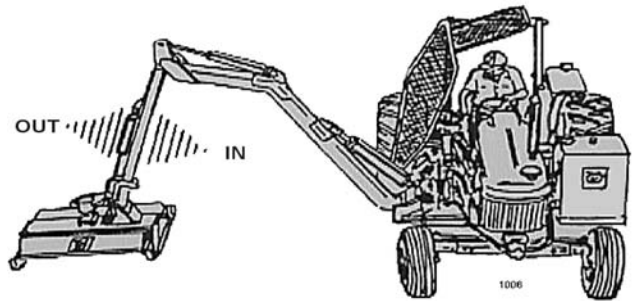

**LEVER #3  
MOVES DECK ROLL**

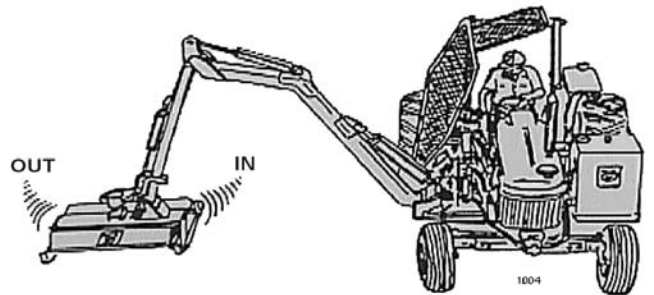

**LEVER #4  
MOVES BOOM SWIVEL**

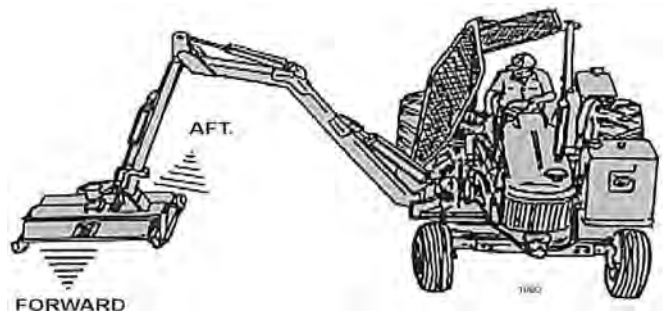

**LEVER #5  
OPERATES SAFETY  
SHIELD**

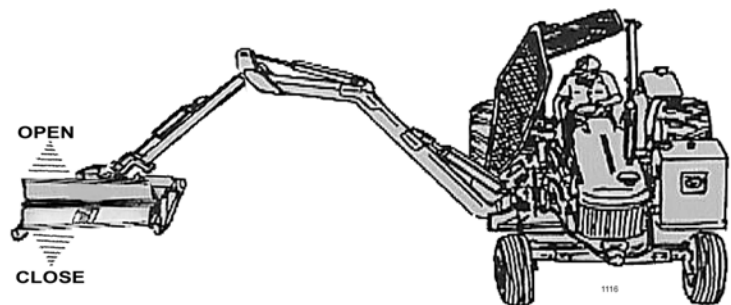

# OPERATION

## UNSTOWING BOOM

To unstow the boom from the boom rest, slowly lift the boom up and away from 3-point mounted boom rest and cab. Damage to the mower or the tractor cab may result if operator does not exercise caution whenever stowing or unstowing the boom.

## MOWER OPERATION

CAUTION!



When rotating parts are in motion, serious injury may occur if caution is not used or danger is not recognized. Never allow bystanders within **300 feet** of the machine when in operation. Extreme care should be taken when operating near loose objects – such as gravel, rocks and debris. These conditions should be avoided.

The rotating parts in this machine have been designed and tested for rugged use. However, they could fail upon impact with heavy solid objects – such as steel guard rails, concrete abutments, etc., causing them to be thrown at a very high velocity. Never allow cutter head to contact such objects. Inspecting the cutting area for such objects prior to mowing can help eliminate these potential hazards.

Once on location, lower the mower deck slightly above the material to be cut, so the mower does not have to start under a load. With the tractor at an idle, engage mower. Bring tractor R.P.M. up to 2200 - 2400 R.P.M. and **slowly** lower deck to ground level.

A flail mower deck should be carried so that part of the deck weight is carried by the boom and part carried by the ground roller, when mowing on the ground. When the flail mower is carried this way, the ground roller follows the contour of the ground more easily during mowing operations.

CAUTION!



When using the rotary cutting head for trimming trees and shrubs, let the mower saw into them. Do not lower the mower head down directly onto a tree or stump. The mower blades are designed to cut with the end, and misuse can cause damage to the blade and a hazardous situation for the operator.

CAUTION!



Powering the boom down, forcing mower deck onto ground may damage mower deck and it's attachment to the boom, creating a potentially hazardous situation.

# OPERATION

To ensure a clean cut, engine speed should be maintained at approximately 2200 – 2400 R.P.M. If the tractor slows to less than 1800 R.P.M., shift to the next lower gear. **DO NOT** ride the clutch, this will cause premature clutch failure. **The engine should not be operated at any time at more than 2400 R.P.M. on the tractor tachometer.**

For cutting brush it is usually best to stop the tractor and swivel the boom and mower into foliage. The horizontal positioning action of the boom is designed to position the cutting head and provide a limited pressure relief when excessive pressure is applied to the boom.

The Cheetah Rotary mower was designed for cutting brush and foliage up to 4 inches in diameter or multiple branches that have a total cross section area equivalent to one 4 inch branch. Cutting multiple limbs at the same time may overload the mower, causing it to slow down or stall. Regardless of the size of material being cut, the speed of the cutter head must be maintained. To ensure that the cutter head is running at maximum speed, run the tractor at 2400 RPM during mowing operations. If the cutter head slows to the point that the knives are folding back, move the mower head away from the foliage and allow the cutter head to regain full speed.

**WARNING!**



Operating the mower in a manner that allows the cutting knives to continually fold back, will cause permanent damage to the knives, rotary disk and spindle assembly.

**WARNING!**



The cheetah rotary cutter head is designed for clockwise rotation (clockwise as seen from the top of the cutter head). **Never operate the cutter head with a counterclockwise rotation. Operating the mower with a counterclockwise rotation will cause objects to be thrown towards the tractor!**

**CAUTION!**



**DO NOT** use excessive force when positioning cutting head into heavy branches or stumps. Damage to the unit may result. It is best to let the cutter head “eat away” slowly at heavy cutting jobs.

**CAUTION!**



If foliage falls on top of mower deck causing tractor to become unstable, push the joystick control “Forward” and to the “Right” to relieve tipping of the tractor. Lower mower deck to ground and shut down unit. After all motion stops, remove foliage from mower deck.

The mower will operate more efficiently in tougher conditions and with less power if the knives are kept sharp. If the mower begins to vibrate, stop the tractor, check for wire wrapped in the spindle or damaged knives. When replacing knives, replace all knives with new knives and bolts to ensure proper balance so the mower will not vibrate. Severe vibration will result, if knives with unequal wear are used.

( CONTINUED )

# OPERATION

Begin a pass at the top side of the trees and work down with each consecutive pass. When cutting trees and shrubs, use a lower speed to allow the knives time to cut as well as mulch the foliage.

## WARNING!



If bystanders approach within 300 feet while mower is in operation turn mower switch “OFF” immediately! After shutdown, never leave the tractor or allow bystanders to approach within **100 yards** of the unit until all motion stops completely.

If cutter shaft jams and stops, turn mower switch to “OFF”, and swivel boom “AFT”. Normally this action will clear the cutter head. If not, roll mower deck until adjacent to the secondary boom, then lower boom to rest mower deck on ground. Shut off the tractor, set parking break, allow all motion to cease. At that point it is safe to leave the tractor and clear the cutter heads manually.

After the first day of operation, all bolts should be checked and tightened securely. This should be done periodically to ensure the bolts do not become loose and cause damage to the tractor or mower, or injury to the operator.

## TRANSPORTING MOWER

### Transporting under the units own power:

When transporting between job sites, the following procedure should be followed: Shut off the power to the cutting head and allow all motion to come to a complete stop. Roll the mower deck all the way back until it is adjacent to the secondary boom. Slowly and carefully swivel the boom “AFT” and bring the secondary boom arm “in” until the main boom is along side the cab and the head is just above the 3-point rest. Lower the main boom until it contacts the saddle on the boom rest. The unit is now ready for self transportation. Use caution at all times when maneuvering the boom arm in and out of the boom rest, or damage to the mower or the tractor may occur.



1133

# OPERATION

## **Transporting unit by flatbed trailer:**

Park flatbed on level area. Drive tractor onto center of flatbed to avoid uneven distribution of weight and staying within local width restrictions. If tractor is over width, the turnbuckles on each side of the 3-point hitch can be adjusted to pull the boom rest and boom arm over.

### **CAUTION!**



If any part of this operating section, or any other section of this manual is not completely understood, contact your Tiger dealer or the address on the cover of this manual for assistance!

**OPERATION**

**INSPECTION SHEETS**



# OPERATION

## BOOM MOWER PRE-OPERATION Inspection



Mower ID# \_\_\_\_\_ Make \_\_\_\_\_

Date: \_\_\_\_\_ Shift \_\_\_\_\_

**WARNING!**



Before conducting the inspection, make sure the Tractor engine is off, all rotation has stop and the tractor is in the Park with the parking brake engaged. The Mower head is resting on the ground (or is securely blocked up and supported) and all hydraulic pressure has been relieved.

Item	Condition at Start of Shift	Specific Comments if not O.K.
The Operator's Manual is in the Canister on the mower		
All Safety Decals are in place and legible		
The Mounting frame bolts are in place and tight		
The Boom connection bolts & pins are tight		
There are no cracks in boom		
The Hydraulic Cylinders pins are tight		
The Hydraulic Pump hose connections are tight		
The Hydraulic Valve hose connections are tight		
The Hydraulic Valve controls function properly		
There are no leaking or damaged hoses		
The Hydraulic Oil level is full		
There is no evidence of Hydraulic leaks		
The Blades are not chipped, cracked or bent		
The Blade bolts are tight		
The Deflectors are in place and in good condition		
The Mower shields are in place and in good condition		
The Skid shoes are in good condition & tight		
There are no cracks or holes in mower deck		
The Hydraulic motor mounting bolts are tight		
The mower head spindle housing is tight and lubricated		

Operators Signature: \_\_\_\_\_

**DO NOT OPERATE an UNSAFE TRACTOR or MOWER**



# OPERATION

## TRACTOR PRE-OPERATION Inspection



Tractor ID# \_\_\_\_\_ Make \_\_\_\_\_

Date: \_\_\_\_\_ Shift \_\_\_\_\_

**WARNING!**



Before conducting the inspection, make sure the Tractor engine is off, all rotation has stop and the tractor is in the Park with the parking brake engaged. The Mower head is resting on the ground (or is securely blocked up and supported) and all hydraulic pressure has been relieved.

Item	Condition at Start of Shift	Specific Comments if not O.K.
The Flashing lights function properly		
The SMV Sign is clean and visible		
The Tires are in good condition with proper pressure		
The Wheel Lug bolts are tight		
The tractor Brakes are in good condition		
The Steering linkage is in good condition		
There are no visible Oil Leaks		
The Hydraulic controls function properly		
The ROPS or ROPS Cab is in good condition		
The Seatbelt is in place and in good condition		
The 3-Point Hitch is in good condition		
The Drawbar pins are securely in place		
The PTO Master Shield is in place		
The Engine Oil level is full		
The Brake Fluid level is full		
The Power Steering Fluid Level is full		
The Fuel level is adequate		
The Engine Coolant Fluid level is full		
The Radiator is free of debris		
The Air filter is in good condition		

Operators Signature: \_\_\_\_\_

**DO NOT OPERATE an UNSAFE TRACTOR or MOWER**

# OPERATION

## FRONT END LOADER PRE-OPERATION Inspection



Mower ID# \_\_\_\_\_ Make \_\_\_\_\_

Date: \_\_\_\_\_ Shift \_\_\_\_\_

**WARNING!**



Before conducting the inspection, make sure the Tractor engine is off, all rotation has stop and the tractor is in the Park with the parking brake engaged. The Loader is resting on the ground (or is securely blocked up and supported) and all hydraulic pressure has been relieved.

Item	Condition at Start of Shift	Specific Comments if not O.K.
The Operator's Manual is in the Canister on the mower		
All Safety Decals are in place and legible		
The Mounting frame bolts are in place and tight		
There are no cracks in Draftbeam or Yolk		
The Draftbeam/Yolk connection bolts & pins are tight		
There are no cracks or holes in mower deck		
The Hydraulic motor mounting bolts are tight		
The mower head spindle housing is tight and lubricated		
There mower deck is clear of cut grass and debris		
The Skid shoes are in good condition & tight		
Chain Guards/Deflectors are in place & in good condition		
Blade carrier retaining nut is tight		
Blades are not chipped, cracked or bent		
Blade bolts are tight		
Transport locks are in good condition		
There are no leaking or damaged hoses		
There is no evidence of Hydraulic leaks		
The Hydraulic Oil level is full		
The Hydraulic Cylinders pins are tight		
The Hydraulic Pump hose connections are tight		
The Hydraulic Valve hose connections are tight		
The Hydraulic Valve controls function properly		
Wheel lug nuts are tight		

Operators Signature: \_\_\_\_\_

**DO NOT OPERATE an UNSAFE TRACTOR or FRONT END LOADER**

# OPERATION

## TRACTOR PRE-OPERATION Inspection



Tractor ID# \_\_\_\_\_ Make \_\_\_\_\_

Date: \_\_\_\_\_ Shift \_\_\_\_\_

**WARNING!**



Before conducting the inspection, make sure the Tractor engine is off, all rotation has stop and the tractor is in the Park with the parking brake engaged. The Loader is resting on the ground (or is securely blocked up and supported) and all hydraulic pressure has been relieved.

Item	Condition at Start of Shift	Specific Comments if not O.K.
The Flashing lights function properly		
The SMV Sign is clean and visible		
The Tires are in good condition with proper pressure		
The Wheel Lug bolts are tight		
The Tractor Brakes are in good condition		
The Steering linkage is in good condition		
There are no visible Oil Leaks		
The Hydraulic controls function properly		
The ROPS or ROPS Cab is in good condition		
The Seatbelt is in place and in good condition		
The PTO Master Shield is in place		
The Engine Oil level is full		
The Brake Fluid level is full		
The Power Steering Fluid Level is full		
The Fuel level is adequate		
The Engine Coolant Fluid level is full		
The Radiator is free of debris		
The Air filter is in good condition		

Operators Signature: \_\_\_\_\_

**DO NOT OPERATE an UNSAFE TRACTOR or FRONT END  
LOADER**

# **MAINTENANCE SECTION**

# MAINTENANCE

Tiger Mowers are designed for high performance and rugged durability, yet with simplified maintenance. The purpose of this section of the manual is to help the operator in the regular servicing of the mower. Regular maintenance at the intervals mentioned will result in the maximum efficiency and long life of the Tiger Mower.

When you purchase a Tiger Mower you also acquire another valuable asset, Tiger's parts organization. Our rapid and efficient service has guaranteed the customer satisfaction for many years. Tiger parts keep up with the demands for efficiency, safety and endurance expected of the Tiger Mower.

## MAINTENANCE PRECAUTIONS

Be sure end of grease gun and zerks are clean before using. Debris injected into bearings, etc. with grease will cause immediate damage.

DO NOT use a power grease gun to lubricate bearings. These require very small and exact amounts of lubrication. Refer to the detailed maintenance section for specific lubrication instructions. **Do Not over-grease bearings.**

Lexan windows should be washed with mild soap or detergent and luke warm water, using a soft clean sponge or **soft cloth**. DO NOT use abrasive or alkaline cleaners or metal scrapers on lexan windows!

Be alert to maintenance indicators such as the in-tank filter pressure gauge, hydraulic reservoir sight gauge, etc. Take the required action to correct any problems immediately.

Release of energy from pressurized systems may cause inadvertent actuation of cylinders, or sudden release of compressed springs. Before disconnecting any hoses relieve pressure by shutting tractor off, setting cutter on ground and actuating lift valve handles.

WARNING!



**DO NOT** use hands to check for suspected leaks in hydraulic hoses! Hydraulic fluid escaping under pressure can have sufficient force to penetrate skin and cause serious injury. If fluid is injected into skin, it must be surgically removed within a few hours or gangrene may result. Use a small piece of wood or cardboard, not hands, to search for pin hole leaks. Be sure all pressure is relieved whenever disconnecting lines. Be sure all connections are tight and hoses and lines are not damaged before applying pressure.

## BREAK IN PERIOD

In addition to following the break in instructions for your particular tractor, the in-tank hydraulic fluid filter should be replaced after the first 50 hours of service. Thereafter the filter should be replaced every 500 hours, or yearly, whichever ever comes first.

Re-torque wheel lugs after first five hours of operation and periodically thereafter. See torque specifications listed in the tractor's service manual for your particular model. **Wheel lugs must always be re-torqued whenever a wheel is removed and reinstalled.**



# MAINTENANCE

## REGULAR MAINTENANCE

The intervals at which regular servicing should be done are based on hours of operation. Use the tractor's hour meter to determine when regular servicing is required.



This symbol indicates a point that needs to be greased at an interval noted in the section below. Refer to the Detailed Maintenance section for further instructions on greasing. Copy and use the Daily Maintenance sheet located at the end of this section.

### DAILY OR EVERY 8 HOURS

ITEM	SERVICE	COMMENTS
Pump Drive Shaft	Check and Lube	Insure drive shaft end play
Crankshaft Adapter	Check rubber grommets	Replace grommets if damaged or missing
Pivot Points	Lubricate	Inject grease until it appears at ends
Hydraulic Fittings	Check for leaks	Tighten when needed. Do Not use hands to check for leaks, see maint. Precautions
Knives	Check	Inspect for missing or damaged knives, change as needed
Knife mounting bolts (knife to disk)	Check	Re - torque to 800 ft. lbs.
Disk mounting bolts (disk to spindle)	Check	Torque to 180 ft lb lubricated Torque to 204 ft lb dry
Spindle mounting bolts (Spindle to Deck)	Check	Torque to 315 Ft lubricated Torque to 357 Ft dry
Belts	Check / Adjust	Check if broken, tighten as required
Main Frame and Deck	Check	Retorque bolts to torque specifications in this section
Hydraulic Fluid Level	Check	Add if required per fluid recommendations
Rear Flail Drive (if applicable) Bearing Flange and Shaft Coupler	Lubricate	Grease as instructed in detailed maint. section
Cutter Shaft and Ground Roller	Lubricate	Grease as instructed in detailed maint. section
Ground Roller Bearings	Lubricate	Grease as instructed in detailed maint. section
Cutter Shaft Bearings (Flail)	Lubricate	Grease as instructed in detailed maint. section

# MAINTENANCE

## WEEKLY OR EVERY 50 HOURS

ITEM	SERVICE	COMMENTS
In Tank Hyd. Fluid Filter <b>(10 micron filter)</b>	Change	Change after the first 50 hours only, then every 500 hours, yearly or if indicated by the restriction indicator.
In-Line High Pressure Filter <b>(10 micron filter)</b>	Change	Change after the first 50 hours only, then every 500 hours, yearly or if indicated by the restriction indicator.
Chain Coupling	Check	

## MONTHLY OR EVERY 150 HOURS

Hydraulic Fluid Level	Check	Add as needed
Hyd. Tank Breather	Clean/Check/Replace	Clean or replace element as required

## YEARLY OR EVERY 500 HOURS

Spindle Grease	Change	
Hyd. Tank Fluid	Change	
In Tank Hyd. Fluid Filter <b>(10 micron filter)</b>	Change	
In-Line High Pressure Filter <b>(10 micron filter)</b>	Change or	Change when indicated by restriction indicator.
Hyd. Tank Breather	Change	

## TROUBLE SHOOTING

SYMPTOMS	CAUSE	REMEDY
<b>Vibration</b>	<ol style="list-style-type: none"> <li>Loose bolts</li> <li>Cutter assembly Unbalanced</li> </ol>	<ol style="list-style-type: none"> <li>Check all bolts and tighten to torque specs. in this section</li> <li>Check for damaged blades, disc. or cutter shaft. Replace if needed.</li> <li>Check for wire, rope, etc. entangled in cutter assembly</li> </ol>
<b>Mower will not lift</b>	<ol style="list-style-type: none"> <li>Hyd. Fluid low</li> <li>Leaks in line</li> <li>Faulty relief valve</li> <li>Kinked or blocked</li> <li>Faulty cylinder</li> </ol>	<ol style="list-style-type: none"> <li>Check and refill Hyd. Fluid</li> <li>Tighten or replace fittings and hoses</li> <li>Check pressure in line. Line pressure in Control Valve should be at least 2500 P.S.I.</li> <li>Clean or replace line.</li> <li>Inspect, repair or replace cylinder</li> </ol>
<b>Mower will not start or run</b>	<ol style="list-style-type: none"> <li>Blown fuse</li> <li>Ball valves closed</li> <li>Low oil level</li> <li>Line leak</li> </ol>	<ol style="list-style-type: none"> <li>Check fuse between mower switch and ignition / replace</li> <li>Make sure valves are open</li> <li>Check Hyd. tank and fill</li> <li>Check all fittings and lines,</li> </ol>



# MAINTENANCE

SYMPTOMS	CAUSE	REMEDY
<b>Mower will not start or run, cont.</b>	1. Electronic solenoid faulty	1a. <b>Without</b> the tractor running, turn the mower switch to on. A low audible click should be heard if the solenoid is engaging the solenoid spool. If click is not heard, leave switch in on position and with a screwdriver or other steel object, touch the small nut on the end of the solenoid. If the metallic object is not attracted to the nut, check the fuse and wiring for an open circuit. If the object is attracted but no "click" is heard, replace the solenoid. 1b. Remove the four bolts holding the small block to the main block. Lift and remove small block being careful not to damage O-rings / filter. Clean filter and re-install. 1c. Remove large nut on side of large valve block. Remove spring, and use needle nose vise grip to pull spool from block. Check block and spool for contaminates and scratches. Clean parts or replace if scratched.
<b>Motor runs but will not cut.</b>	1. Belts 2. Tensioner	1. Inspect belts and pulleys. Replace belts and repair as needed. 2. Adjust tensioner nut until flat washer washer is flush with top of guide.
<b>Motor turns slowly or not at all.</b>	1. Contaminants restricting spool movement in valve body. 2. Suction lines obstructed 3. Low oil level	1. . Remove large nut on side of large valve block. Remove spring, and use needle nose vise grip to pull spool from block. Check block and spool for contaminates and scratches. Clean parts or replace if scratched. 2. Check for kinkes or obstruction in suction hose 3. Check Hyd. tank level and fill
<b>Pump will not work</b>	1. Excessive wear on internal parts	1. Disassemble and repair.
<b>Motor will not work</b>	1. Excessive wear on internal parts	1. Disassemble and repair.





NOTE: If flow meter is available, check pressure and flow volume for all suspected hydraulic problems.

**If the solution to your problem cannot be found in this section, call the Technical Service representative at the number shown on the front cover of**

# MAINTENANCE

## TORQUE SPECIFICATIONS

### Torque for Standard Fasteners

Nominal Dia. (in.)	threads per inch	 Grade 2			 Grade 5			 Grade 8			 Grade 9		
		Tightening Torque			Tightening Torque			Tightening Torque			Tightening Torque		
		Lubed	Dry Plated	Dry plain	Lubed	Dry Plated	Dry plain	Lubed	Dry Plated	Dry plain	Lubed	Dry Plated	Dry plain
		K = 0.15	K = 0.17	K = 0.20	K = 0.15	K = 0.17	K = 0.20	K = 0.15	K = 0.17	K = 0.20	K = 0.15	K = 0.17	K = 0.20

### Unified Coarse Thread Series

Nominal Dia. (in.)	Threads per inch	49 in-lbs	59 in-lbs	66 in-lbs	76 in-lbs	86 in-lbs	101 in-lbs	107 in-lbs	122 in-lbs	143 in-lbs	126 in-lbs	143 in-lbs	168 in-lbs
1/4	20	49	59	66	76	86	101	107	122	143	126	143	168
5/16	18	101	122	135	157	178	209	221	251	295	259	294	346
3/8	16	15 ft-lbs	18 ft-lbs	20 ft-lbs	23 ft-lbs	26 ft-lbs	31 ft-lbs	33 ft-lbs	37 ft-lbs	44 ft-lbs	38 ft-lbs	43 ft-lbs	51 ft-lbs
7/16	14	24	29	32	37	42	49	52	59	70	61	70	82
1/2	13	37	44	49	57	64	75	80	90	106	94	106	125
9/16	12	53	63	70	82	92	109	115	130	154	135	153	180
5/8	11	73	87	97	113	128	150	159	180	212	186	211	248
3/4	10	129	155	172	200	227	267	282	320	376	331	375	441
7/8	9	125	150	167	322	365	429	455	515	606	533	604	710
1	8	187	225	250	483	547	644	681	772	909	799	905	1065
1 1/8	7	266	319	354	596	675	794	866	1095	1288	1132	1283	1510
1 1/4	7	375	450	500	840	952	1121	1363	1545	1817	1597	1810	2130
1 1/2	6	652	783	869	1462	1657	1950	2371	2698	3162	2779	3150	3706

### Fine Thread Series

Nominal Dia. (in.)	Threads per inch	56 in-lbs	68 in-lbs	75 in-lbs	87 in-lbs	99 in-lbs	116 in-lbs	123 in-lbs	139 in-lbs	164 in-lbs	144 in-lbs	163 in-lbs	192 in-lbs
1/4	28	56	68	75	87	99	116	123	139	164	144	163	192
5/16	24	112	135	150	174	197	231	245	278	327	287	325	383
3/8	24	17 ft-lbs	20 ft-lbs	23 ft-lbs	26 ft-lbs	30 ft-lbs	35 ft-lbs	37 ft-lbs	42 ft-lbs	49 ft-lbs	43 ft-lbs	49 ft-lbs	58 ft-lbs
7/16	20	27	32	36	41	47	55	58	66	78	68	78	91
1/2	20	41	49	55	64	72	85	90	102	120	105	120	141
9/16	18	59	71	78	91	103	121	128	146	171	151	171	201
5/8	18	82	99	110	127	144	170	180	204	240	211	239	281
3/4	16	144	173	192	223	253	297	315	357	420	369	416	492
7/8	14	138	165	184	355	403	474	502	568	669	588	666	784
1	14	210	252	280	542	614	722	765	867	1020	896	1016	1195
1 1/8	12	298	357	397	668	757	890	1063	1227	1444	1269	1439	1693
1 1/4	12	415	498	553	930	1055	1241	1509	1710	2012	1768	2004	2358
1 1/2	12	734	880	978	1645	1865	2194	2668	3024	3557	3127	3544	4189

Torque values for 1/4 and 5/16-in series are in inch-pounds. All other torque values are in foot-pounds. K = 0.15 for "lubricated" conditions. D = Nominal Diameter  
 Torque values calculated from formula T=KDF, where K = 0.17 for zinc plated and dry conditions F = Clamp Load  
 K = 0.20 for plain and dry conditions.

### Torque-Tension Relationship for Metric Fasteners

Nominal Dia. (mm)	Pitch	Class 4.6			Class 8.8			Class 10.9			Class 12.9	
		Tightening Torque			Tightening Torque			Tightening Torque			Tightening Torque	
		Lubed	Dry Plated	Dry plain	Lubed	Dry Plated	Dry plain	Lubed	Dry Plated	Dry plain	Lubed	Dry plain
		K = 0.15	K = 0.17	K = 0.20	K = 0.15	K = 0.17	K = 0.20	K = 0.15	K = 0.17	K = 0.20	K = 0.15	K = 0.20
3	0.5	0.28	0.32	0.38	0.73	0.82	0.97	1.0	1.2	1.4	1.2	1.6
3.5	0.6	0.44	0.50	0.59	1.1	1.3	1.5	1.6	1.9	2.2	1.9	2.5
4	0.7	0.66	0.74	0.87	1.7	1.9	2.3	2.4	2.7	3.2	2.8	3.8
5	0.8	1.3	1.5	1.8	3.4	3.9	4.5	4.9	5.5	6.5	5.7	7.6
6	1	2.3	2.6	3.0	5.8	6.6	7.7	8.3	9.4	11	9.7	13
8	1.25	2.1	2.3	2.7	5.3	6.0	7.0	7.6	8.6	10	8.8	12
7	1	3.8	4.3	5.0	9.7	11	13	14	16	19	16	22
8	1	5.9	6.6	7.8	15	17	20	22	24	29	25	34
8	1.25	5.5	6.2	7.3	14	16	19	20	23	27	24	31
10	1.25	11	13	15	29	33	39	42	48	56	49	66
10	1.5	11	12	14	28	32	37	40	45	53	47	62
12	1.25	21	23	28	53	60	71	76	86	101	89	119
12	1.5	20	22	26	51	58	68	73	82	97	85	113
12	1.75	19	21	25	49	55	65	70	79	93	81	108
14	1.25	26	29	34	66	75	89	95	108	127	111	148
14	1.5	28	32	37	72	82	96	103	117	138	121	161
14	2	30	34	40	78	88	104	111	126	148	130	173
16	1.5	50	57	67	129	146	171	184	208	245	215	287
16	2	47	53	62	121	137	161	173	196	230	202	269
18	1.5	73	82	97	187	212	249	268	303	357	313	417
18	2.5	65	73	86	167	189	222	239	270	318	279	372
20	2.5	91	104	122	238	267	314	337	382	449	394	525

Clamp load calculated as 75% of the proof load for specified bolts. K = 0.15 for "lubricated" conditions. D = Nominal Diameter  
 All torque values are listed in foot-pounds. K = 0.17 for zinc plated, dry conditions. F = Clamp Load  
 Torque values calculated from formula T=KDF, where K = 0.20 for plain and dry conditions.

\* These are intended to be general specifications. See tractor operators or service manual for exact specifications for your tractor parts.

# MAINTENANCE

## LUBRICATION RECOMMENDATIONS

Description	Application	General Specification	Recommended Mobil Lubricant
Tractor Hydraulics	Reservoir	JD-20C MF M1135,M1141 FNHM2C134D (FNH201)	Mobilfluid 424
Mower Hydraulics	Reservoir		
Cold Temperatures 0 F Start-Up		ISO 46 Anti-Wear - Low Temp	Mobil DTE 15M
Normal Temperatures 10 F Start-Up		JD-20C MF M1135,M1141 FNH M2C134D (FNH201)	Mobilfluid 424
Normal Temperatures 15 F Start-Up High Operating Temp. Above 90 F		ISO 46 Anti-Wear ISO 100 Anti-Wear	Mobil DTE 25 Mobil DTE 18M
Flail Rear Gearbox	Grease	PAO Synthetic Extreme Pressure Gear Lube	Mobil SHC 75W-90 Mobil 1 Synthetic Gear
Cutter Shaft & Ground Roller Shaft (Flail)	Grease Gun	Lithium-Complex Extreme Pressure NLGI 2 - ISO 320	Mobilgrease CM-S
Drive Shaft Coupler (Flail and Rotary)	Grease Gun	Lithium-Complex Extreme Pressure NLGI2 - ISO 320	Mobilgrease CM-S
Boom Swivel Boom Cylinder Pivots (Rotary & Flail Boom)	Grease Gun	Lithium-Complex Extreme pressure NLGI2 - ISO 320	Mobilgrease CM-S
Deck Boom Pivot & Deck Stop Adjustment (Rotary & Flail)	Grease Gun	Lithium-Complex Extreme pressure NLGI 2 - ISO 320	Mobilgrease CM-S
Deck Spindle (Rotary)	Grease Gun	Tiger Spindle Lubricant part number 06540000	Mobilith SHC 220

# MAINTENANCE

## POLYCARBONATE CARE & MAINTENANCE

The proprietary UV and Abrasion Resistant surface coating on SHIELDS® SUPERCOATED™ polycarbonate significantly improves performance. Periodic cleaning using proper procedures and compatible cleaners are recommended to prolong service life. Tiger Corp. polycarbonate is SUPERCOATED™ on both sides.

### CLEANING THE SUPERCOAT™ HARD-COAT

1. Wash with a mild solution of soap or detergent and lukewarm water.
2. Using a soft cloth or sponge, gently wash the sheet to loosen dirt and grime and rinse well with clean water.
3. To prevent water spotting, thoroughly dry with chamois or cellulose sponge.
4. Avoid the use of abrasive cleaners, squeegees and/or other cleaning implements that may mar or gouge the coating.

### CLEANING AGENTS WHICH HAVE BEEN FOUND TO BE COMPATIBLE UNDER LABORATORY CONDITIONS:

- Aqueous Solutions of Soaps and Detergents  
Windex<sup>1</sup>                      Top Job<sup>2</sup>                      Joy<sup>2</sup>                      Mr. Clean<sup>2</sup>  
Fantastik<sup>3</sup>                      Formula 409<sup>4</sup>                      Sumalight D12                      Brucodecid
- Organic Solvents  
Butyl Cellosolve                      Kerosene                      Hexel, F.O. 554                      Naphtha (VM&P grade)  
Neleco-Placer                      Turco 5042
- Alcohols  
Methanol                      Isopropyl

All residual organic solvents should be removed with a secondary rinse.

---

### GRAFFITI REMOVAL

Butyl cellosolve (for removal of paints, marking pen inks, lipstick, etc.). The use of masking tape, adhesive tape or lint removal tools works well for lifting off old weathered paints.

To remove labels, stickers, etc., the use of kerosene or VM&P naphtha are generally effective. When the solvent will not penetrate sticker material, apply heat (hair dryer) to soften the adhesive and promote removal.

---

**IMPORTANT:** If a material is found to be incompatible in a short-term test, it will usually be found to be incompatible in the field. The converse, however, is not always true. Favorable performance is no guarantee that actual end-use conditions have been duplicated. Therefore, these results should be used as a guide only and it is recommended that the user test the products under actual end-use conditions.



# MAINTENANCE

## RECOMMENDED FILLING INSTRUCTIONS FOR HYDRAULIC RESERVIORS

When filling or checking the oil level, the unit should be parked on a level surface, shut “OFF”, and allowed sufficient time to cool to ambient temperature. Use caution when removing the pressurized breather. Do not place face over opening when removing the breather.

The reservoir should be filled to the top of the lower sight glass on the side of the tank. Do not over-fill. The reservoir has been over-filled when oil is visible in the upper sight glass. If tank has too much oil, the excess may be expelled through the pressurized breather.

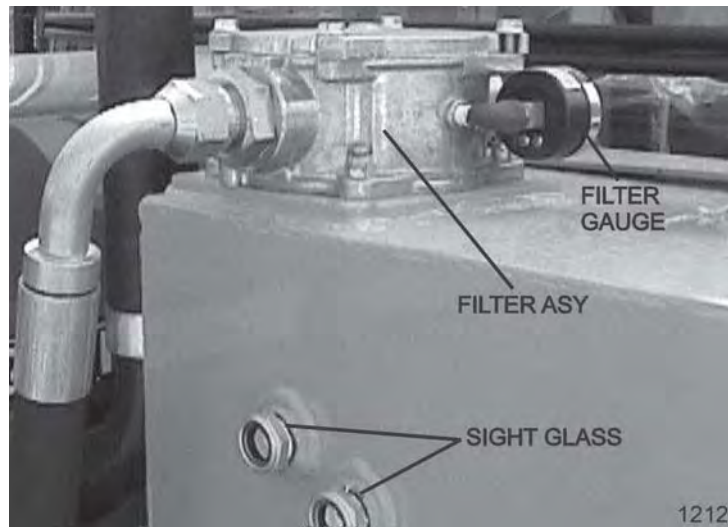

## DETAILED MAINTENANCE

### REPLACING IN-TANK HYDRAULIC FILTER:

Loosen the four bolts on the top cover of the filter housing. Turn cover counter-clockwise until cover is free. Remove and replace filter.

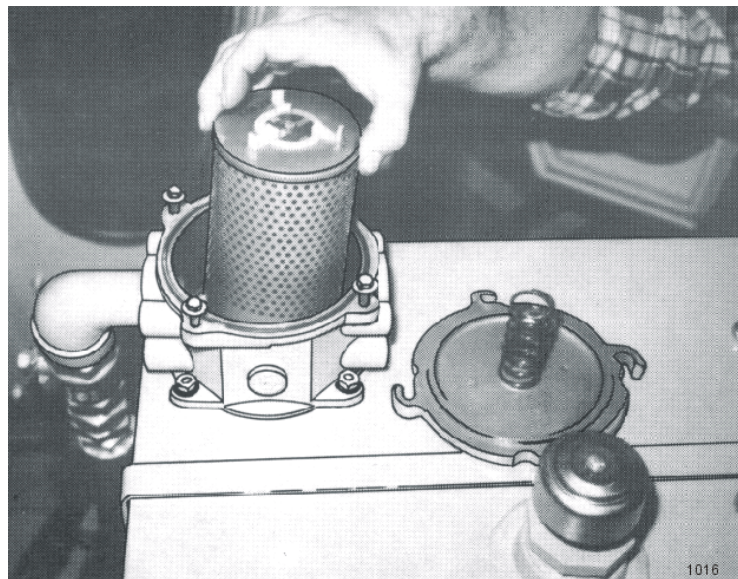

# MAINTENANCE

## DETAILED MAINTENANCE

### REPLACING HIGH PRESSURE HYDRAULIC FILTER ELEMENT:

Assure system has been shut down and de-pressurized. Locate High Pressure Filter housing. Confirm that the element that is about to be installed matches the element p/n on the filter model tag. Example: V3.0510-06 (world line 100, HD049 model) Locate the bottom of the High Pressure Bowl, and use the appropriate spanner wrench –or- ratchet that matches the hex pattern. Using the spanner wrench -or- ratchet and turning in a counterclockwise rotation, (looking at the bottom of the bowl) remove the bowl from the head. The first couple rotations will seam tight as the o-ring passes the sealing flats, once the o-ring has cleared the sealing flats the bowl should spin freely. Taking care not to drop the bowl, finish removing the bowl from the head. **WARNING:** bowl will be full of oil! Pour the oil from the bowl into a container, this oil should be considered contaminated due to the flow direction through the element is outside ~ in. Clean the inside of the bowl if “dirt” is present. Remove the old element from the filter head by pulling with a rotation motion. Dispose of the used element properly. Remove the new element from the packaging. Using your finger, dab and lubricate the o-ring in the top of the new element. Install the new element into and on the mounting boss with in the head; assure that the element is fully seated on the boss. Clean and inspect the o-ring that is affixed in the bowl, lubricate with oil. Using a clockwise rotation, screw the bowl back into the head, assuring that the bowl has not been cross threaded into the head. Continue “tighten” the bowl into the head, using the spanner wrench –or- ratchet, the rotation of the bowl will become tighter once the o-ring engages the sealing flats. Once the bowl has been fully inserted into the head, and the o-ring has reached the sealing flats, the bowl can no longer be “tightened” and bottoms out. Once the bowl has bottomed out, “back-off” the bowl by 1/6 turn, this assures that the o-ring is seated properly with in the sealing flats. Element change out and re-assembly is now complete. Start the machine and inspect the filter area checking that there is no oil leaking from the filter assembly. This is first to be done at 50 hours of operation, then yearly(500 hours) or when indicated by restriction indicator.

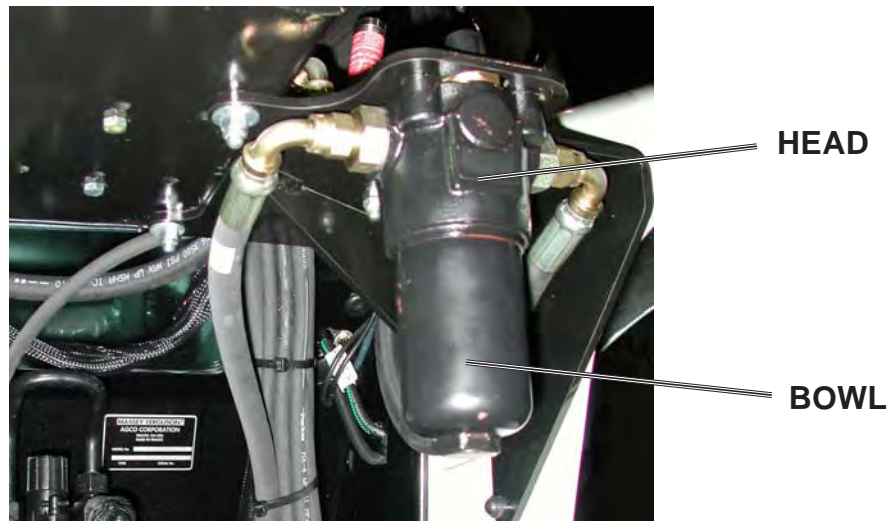

# MAINTENANCE

## GREASING PIVOT POINTS - BOOM AND SWIVEL

Locate grease zerks (8) on deck pivot assembly, (2) on deck end of secondary boom, (2) at main / secondary boom joint, and (2) at swivel end of main boom. Inject Lithium-Complex Extreme Pressure grease conforming to NLGI2-ISO 320 specifications until grease begins to protrude from ends every 8 hours or daily.

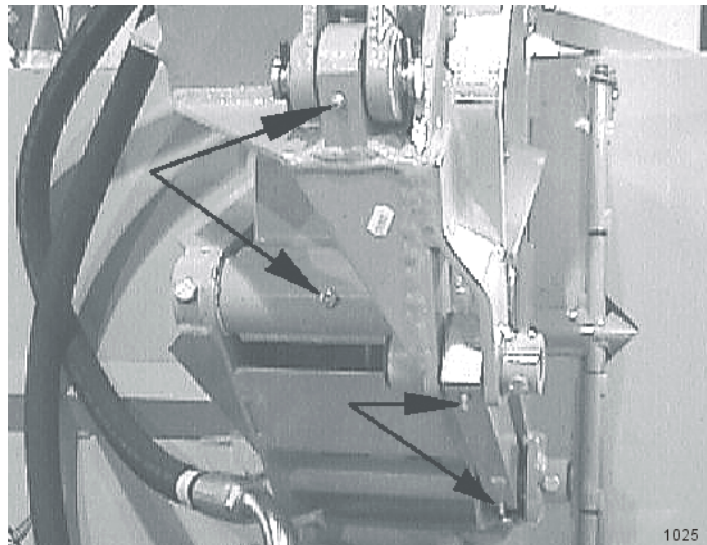

## GREASING SPINDLE

Locate grease fitting on inside of deck housing. Inject Tiger Spindle Lubricant, part number 06540000 into spindle housing. Fill with lubricant until lubricant weeps out of the top spindle seal. Lubricate spindle weekly or every 40 hours of use.

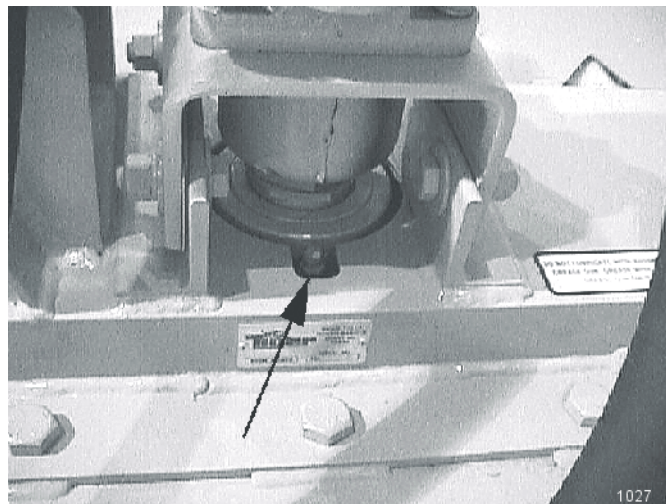



# MAINTENANCE

## TIGHTENING KNIFE BOLTS AND DISK BOLTS:

After every 8 hours of operation or daily, the Knife Bolts and Disk Bolts should be tightened as follows:

Knife mounting bolts (2ea) torque to 800 ft. lbs. lubricated

Disk mounting bolts (6ea) torque to 204 ft. lbs. dry or to 184 ft. lbs. lubricated (loctite 271)



## TIGHTENING SPINDLE BOLTS

The spindle mounting bolts should be checked and retorqued daily or every 8 hours of service as follows:

Torque the (6) bolts shown below to 357 ft. lbs. dry or 315 ft. lb. lubricated (loctite 271)

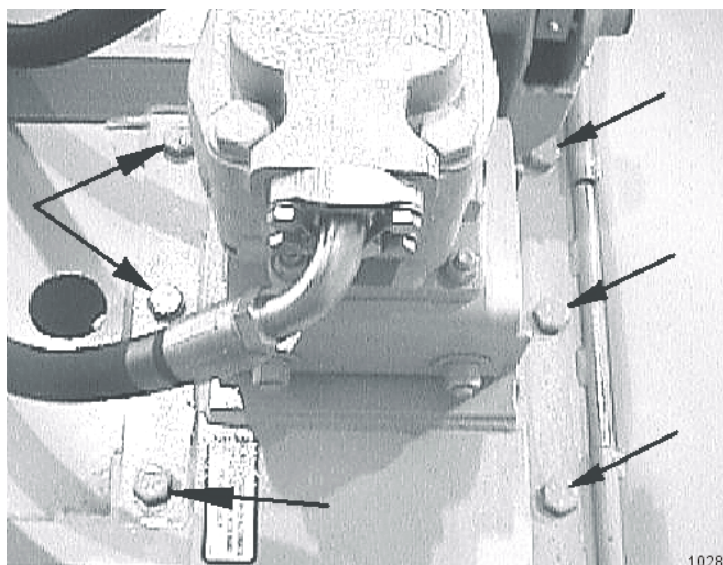

# MAINTENANCE

## GREASING THE BOOM SWIVEL

Locate the zerks on the main swivel boss (2), main boom pivot boss (2) and on both ends of the boom swivel cylinder. Inject Lithium-Complex Extreme Pressure grease conforming to NLGI2-ISO 320 specifications until grease begins to protrude from ends.

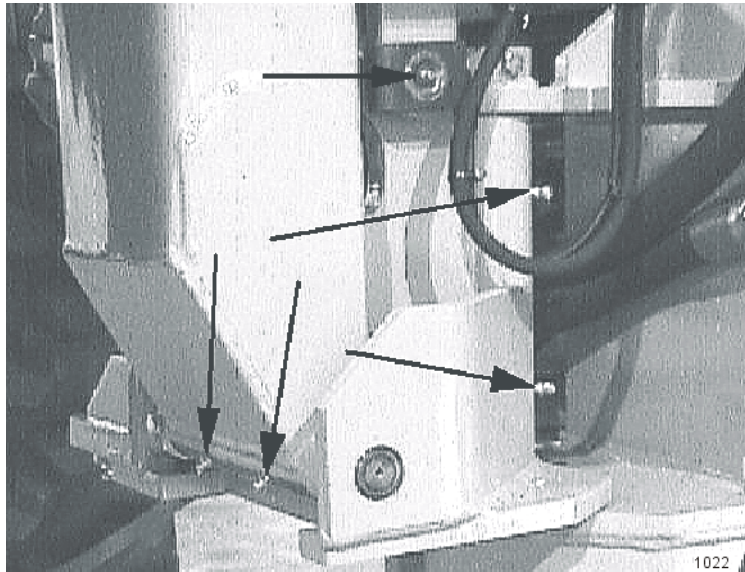

## GREASING PUMP DRIVE SHAFT COUPLER

With engine stopped, ensure drive shaft alignment by grasping coupler and sliding back and forth. Coupler should slide freely with approximately 1/8" of end play. If coupler does not slide freely, inspect for loose pump mount bolts, or damaged or loose crank shaft adapter. Inject Lithium-Complex Extreme Pressure grease conforming to NLGI2-ISO 320 specifications into coupler until grease begins to protrude from ends. Grease daily or every 10 hours. Do not over grease.

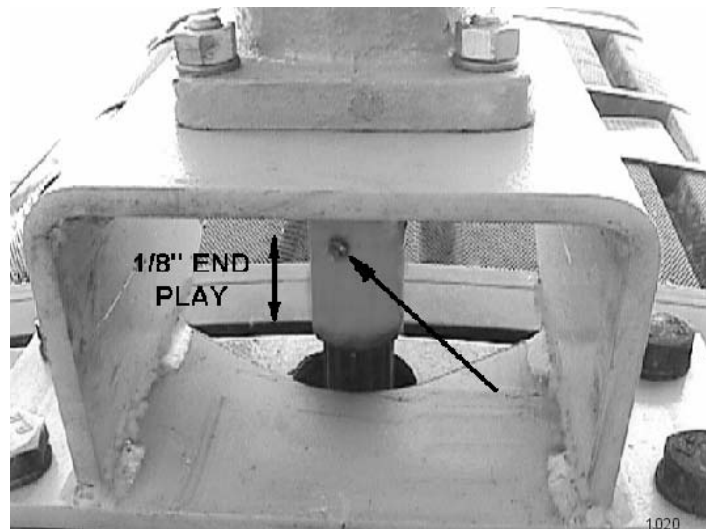

# MAINTENANCE

## BALL VALVES

The ball valve at the hydraulic reservoir may need to be closed during certain maintenance or repair procedures. **THE BALL VALVES MUST BE OPEN (handle parallel with valve) WHEN TRACTOR IS RE-STARTED OR PUMP IS COUPLED TO MOTOR OR P.T.O. !** Failure to do so may result in component failure!

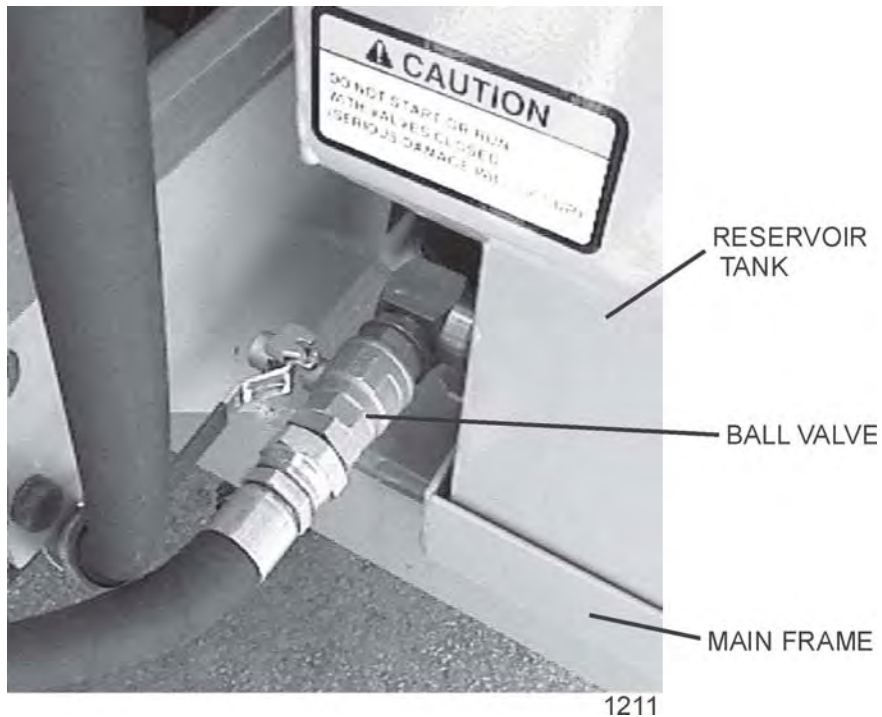

# MAINTENANCE

## GREASING BOOM CYLINDER PIVOT POINTS

Locate the zerk on the butt end tang of cylinder and on rod end tang. Inject Lithium-Complex Extreme Pressure grease conforming to NLGI2-ISO 320 specifications until grease begins to protrude from ends. This procedure is to be used on the main boom cylinder, secondary boom cylinder, deck pivot, and swivel cylinders daily or at 8 hour intervals.



## BOOM FLAIL KNIFE REPLACEMENT

1 – If knives are damaged or badly worn, they will need to be replaced as a set. Replacing a single knife can cause severe vibration and possible damage to the mower.

2 – Assemble knives, bushings, collars, bolts and nuts as shown in part section of manual.

3 – Install locking hex nut so that the flat face of nut is towards the knife.

4 – apply loctite “271” or equivalent to threads.

5 – Torque nut to 50 FT. LBS. Knife must swing freely.

### WARNING!



**DO NOT re-use the locking hex nuts for mounting the knives. If hex nut become loose, or require removal for knife replacement or any other reason, they must be discarded and replaced with new nuts.**

### WARNING!



**Knives should not be welded on for any reason.**

# MAINTENANCE

## CHEETAH SPINDLE ASSEMBLY

### INSTALLATION AND BEARING ADJUSTMENT

**WARNING!** A press MUST be used to install bearing cups, bearing cones, and seals. DO NOT use a hammer to install races, bearings, or seals. The parts of assembly may be damaged.

**NOTE:** The grease zerk and gussets are located on the top side of the spindle housing. Be sure the spindle is assembled correctly.

**Be sure to wear eye protection and other protective equipment as needed when working on spindle assembly.**

## THE SPINDLE ASSEMBLY

See the diagram below for identification of spindle parts, while servicing.

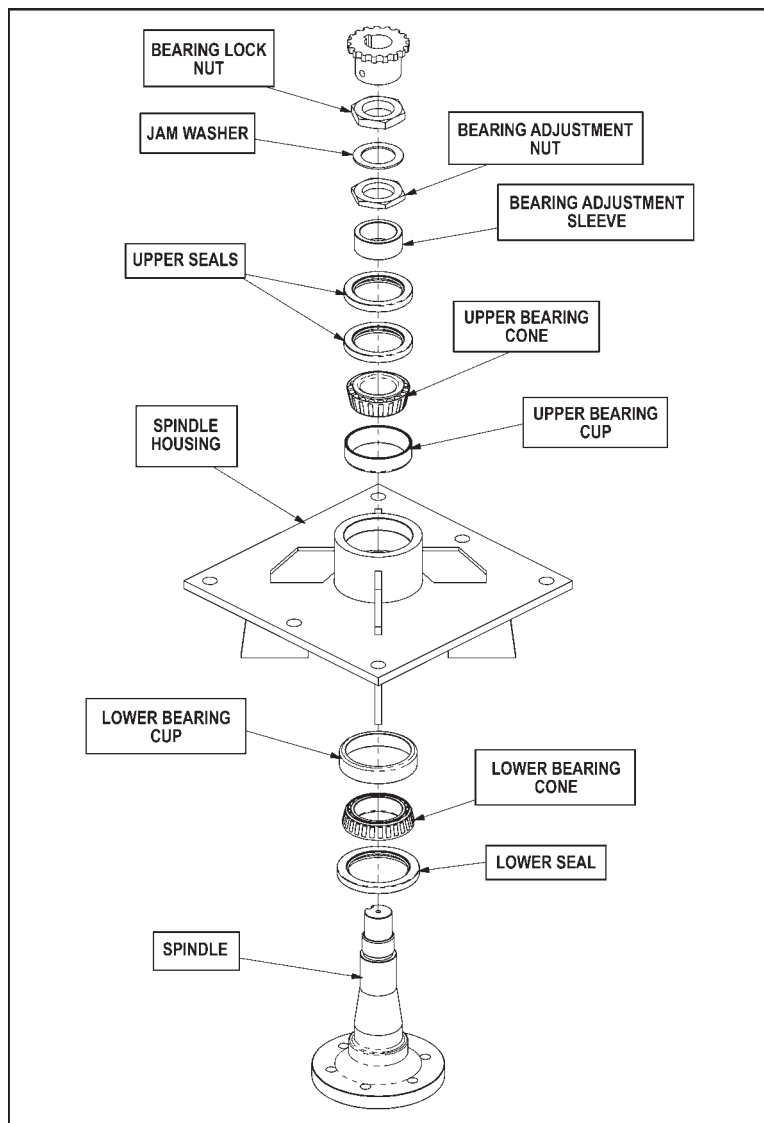



# MAINTENANCE

## BEARING INSTALLATION

- 1 – Press upper bearing cup into the spindle housing.
  - 2 – Turn the spindle housing over and press in the lower bearing cup.
  - 3 – Place the lower bearing cone in the bearing cup. Next press the seal into the spindle housing. The inner lip of the seal must be **DOWN**, towards the bearing, so lubricant is sealed inside the housing.
  - 4 – Install the spindle in the housing. Lightly press the spindle to seat the cone onto the spindle.
  - 5 – Support the bottom of the spindle and press the upper bearing cone and bearing adjustment sleeve onto the spindle.
- NOTE:** The spindle housing must turn freely when seating the bearing cone and sleeve.
- 6 – Press the two upper seals into the spindle housing. The inner lip of the seals must be **UP**, away from the bearing, so excess lubricant can escape.
  - 7 – Install the bearing adjustment nut (thin nut) so there is 1/16" clearance between the nut and the sleeve. Install the jam washer, placing the tab into the key-way. Install the bearing lock nut (thick nut) and hand tighten against jam washer and adjustment nut. See the following section for bearing adjustment.
  - 8 – Position the spindle housing horizontally with the drain hole oriented "up." Grease through the zerk with Tiger Spindle Lubricant(part number 06540000) until the grease purges from the drain hole.
  - 9 – Install the plug into the drain hole.

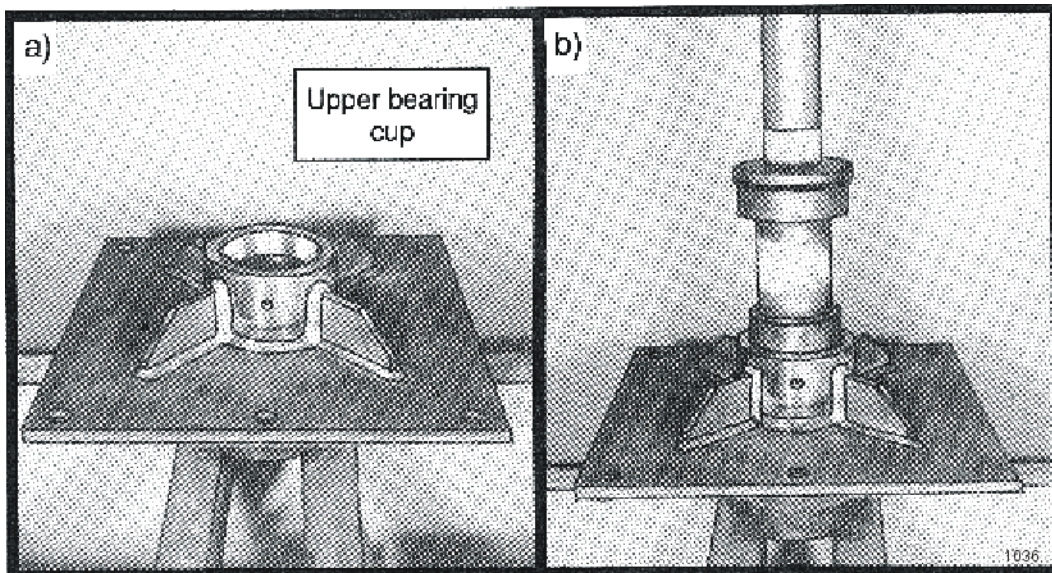

# MAINTENANCE

## BEARING ADJUSTMENT

1 – Clamp the bottom end of the spindle securely in a vise so the spindle housing turns freely.

2 – Position a magnetic base dial indicator on the outer diameter of the spindle housing. Locate the end of the dial indicator against the flat end of the spindle shaft. The dial indicator will now measure accurately bearing end play.

3 – Tighten the bearing adjustment nut until there is .012 inch movement when the spindle housing is pried upward away from the vise jaws.

4 – When there is .012 inch free play between the spindle and housing, install the bearing lock nut (thick nut). Hold the adjusting nut securely and tighten the lock nut to 300 ft. lbs. of torque.

5 – After the lock nut is tightened, there must be .001 inch to .003 inch of free play when lightly prying up on the spindle housing.

If the end play is correct, .001 inch to .003 inch, bend tabs up on jam washer to prevent the lock nut from loosening.

If the end play is NOT correct, loosen the lock nut and turn the adjustment nut as required and re-tighten the lock nut. Repeat first part of step 5.

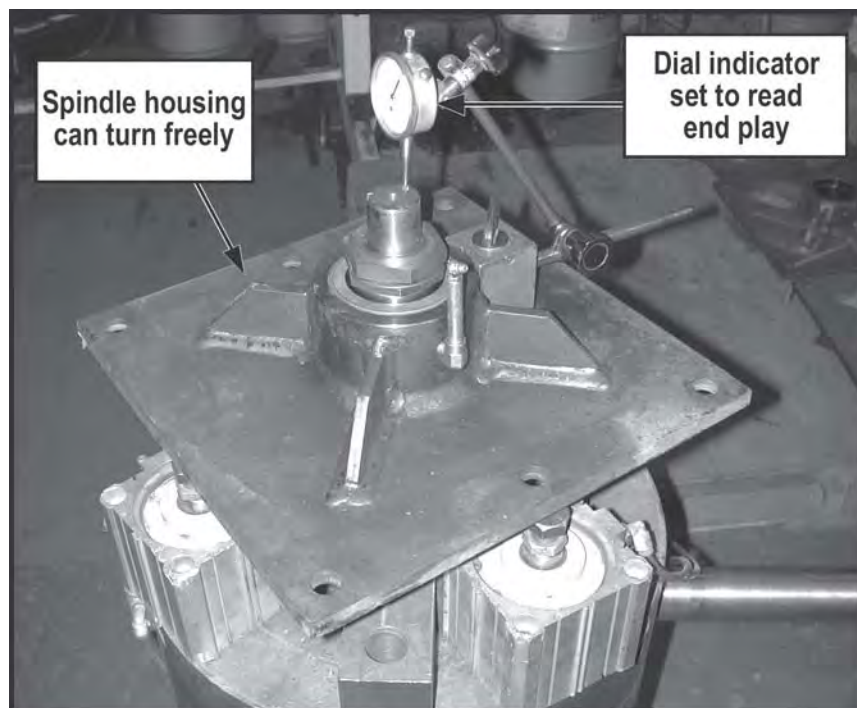



# MAINTENANCE

## DAILY MAINTENANCE SCHEDULE

The following services should be performed **daily** or every **8 hours** of service, following the detailed maintenance instructions in the operators manual.

\_\_\_\_\_ Pump Drive Shaft: Check for end play in drive shaft / coupler and lubricate zerk on coupler.

\_\_\_\_\_ Crankshaft adapter: If equipped with rubber grommets check condition, replace if missing or damaged.

\_\_\_\_\_ Pivot points: Inject grease until it appears at ends.

\_\_\_\_\_ Hydraulic fittings: Check for leaks with paper or cardboard. Tighten fittings or replace hoses immediately.

\_\_\_\_\_ Knives: Inspect for missing or damaged knives, change (only complete sets) as needed.

\_\_\_\_\_ Blade Bolts(1 1/8"): Check/Torque to 800 oiled ft lb. lubricated

\_\_\_\_\_ Check / Torque Disk Bolts 204 ft. lbs. dry and Spindle bolts 357 ft. lbs. dry.

\_\_\_\_\_ Belts: Check / Tighten / Replace belts as needed.

\_\_\_\_\_ Main Frame / Deck: Unless otherwise specified retorque bolts according to torque specifications in this section.

\_\_\_\_\_ Hydraulic Fluid Level: Add, if required, per fluid recommendations.

\_\_\_\_\_ Rear Flail Drive, Bearing Flange and Shaft Couplers: Grease as instructed in the detailed (if applicable) maintenance section.

\_\_\_\_\_ Cutter Shaft and Ground Roller: Grease as instructed in the detailed maintenance section.

Service performed by: \_\_\_\_\_ Date: \_\_\_\_/\_\_\_\_/\_\_\_\_ Hour Meter: \_\_\_\_\_

### Maintenance Section

\*\* This page may be copied and used as part of the daily maintenance routine.

# MAINTENANCE

# **JD 5101E - CHEETAH BOOM MOWER**

## **PARTS SECTION**

# PARTS ORDERING GUIDE

The following instructions are offered to help eliminate needless delay and error in processing purchase orders for the equipment in this manual.

1. The Parts Section is prepared in logical sequence and grouping of parts that belong to the basic machine featured in this manual. Part Numbers and Descriptions are given to help locate the parts and quantities required.

2. The Purchase Order must indicate the **Name and Address** of the person or organization ordering the parts, **who should be charged**, and if possible, the **serial number of the machine** for which the parts are being ordered.

3. The purchase order must clearly list the **quantity of each part**, the complete and correct **part number**, and the basic **name of the part**.

4. The manufacturer reserves the right to substitute parts where applicable.

5. Some parts may be unlisted items which are special production items not normally stocked and are subject to special handling. Request a quotation for such parts before sending a purchase order.

6. The manufacturer reserves the right to change prices without prior notice.

NOTE: When ordering replacement decals, refer to the part numbers and descriptions listed in the safety section in the front of this manual.



1000

For maximum safety and to guarantee optimum product reliability, always use genuine **Tiger** replacement parts. The use of inferior replacement parts may cause premature or catastrophic failure which could result in serious injury or death.

Direct any questions regarding parts to:

**Tiger Corporation**  
3301 N. Louise Ave.  
Sioux Falls, SD 57107  
**1-800-843-6849**  
**1-605-336-7900**

# PARTS SECTION TABLE OF CONTENTS

<b>SECTION</b>	<b>ASSEMBLY</b>	<b>PAGE</b>
<b>TRACTOR SPECIFIC PARTS:</b>		
TRACTOR MNT. KIT - MAIN FRAME, 5101E	06101775	5-4
TRACTOR MOUNT KIT - HYDRAULICS	06101775	5-6
TRACTOR MNT. KIT - MNFRM LOADER		5-8
TRACTOR MOUNT KIT - HYDRO LOADER		5-10
TRACTOR MOUNT KIT - WHEEL WELL TANK		5-12
TRACTOR MOUNT KIT - HYDRO WHEEL WELL TANK		5-14
BOOM MOUNT KIT - BOOM SWIVEL / REST		5-16
SWITCH BOX AND JOYSTICK		5-18
LIFT VALVE - JOYSTICK CONTROL, CAB		5-20
5SP CABLE CONTROLS		5-22
LIFT VALVE - CABLE CONTROL, CAB		5-24
SAFETY SCREEN WINDOW		5-26
WHEEL SPACER		5-27
WHEEL WEIGHT		5-28

# TRACTOR MOUNT KIT - MAIN FRAME 5101E

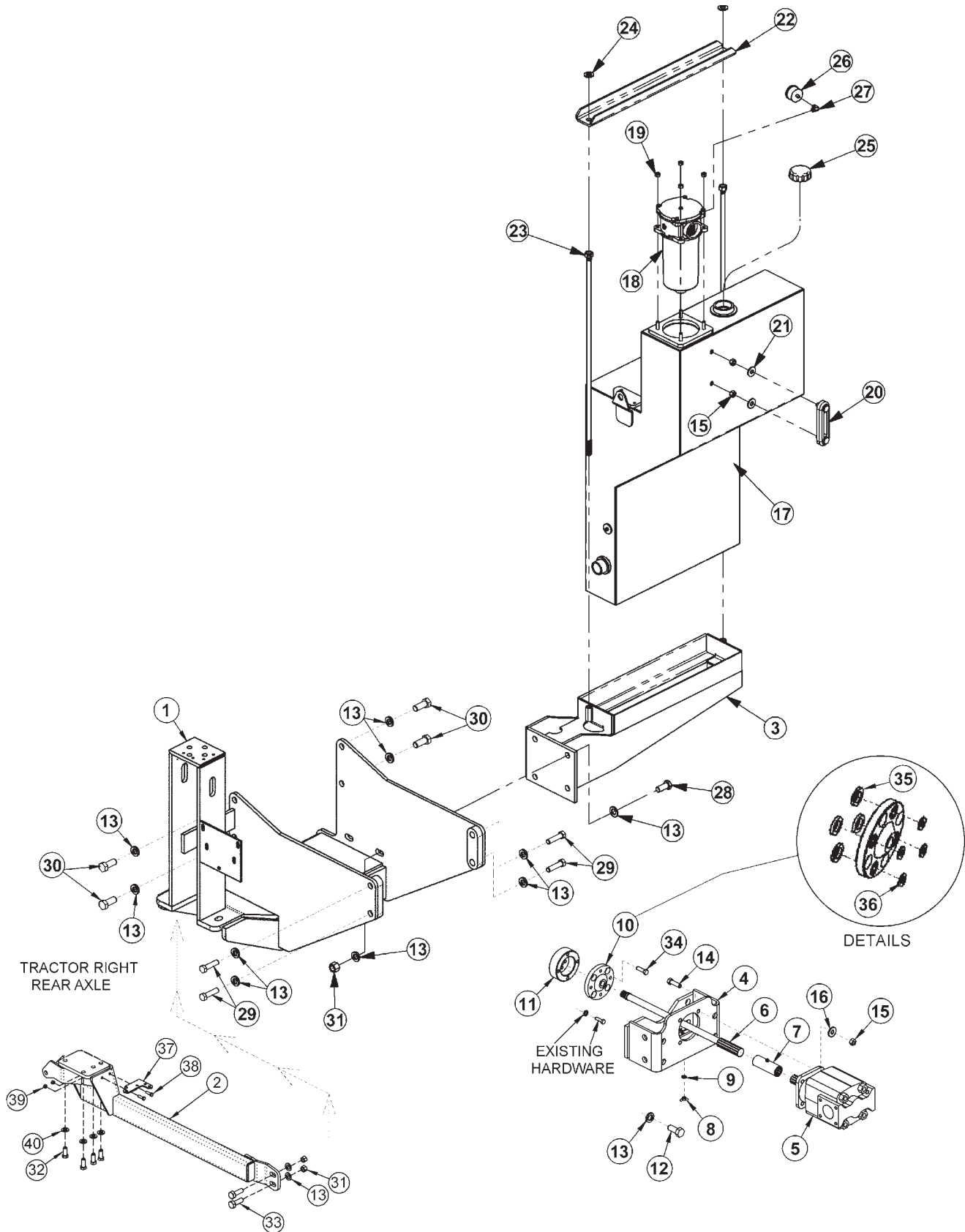



# TRACTOR MOUNT KIT - MAIN FRAME 5101E

ITEM	PART NO.	QTY.	DESCRIPTION
1	06300033	1	MNFRM,JD5525,CHET,TSF/TM
2	06300035	1	AXLE BRACE,RIGHT HAND
3	06300088	1	MOUNT,TANK
4	32642	1	PUMP MOUNTING BRACKET
5	23152	1	PUMP,P350-1 3/4 GEAR
6	06520135	1	DRIVE SHAFT,PUMP,27 7/8"
7	6T0375B	1	COUPLING,14 SPLINE,W/ZERK,4
8	32519	1	NUT,WING,1/4-20 UNC
9	22014	1	FLATWASHER,1/4
10	6T0389	1	CRANKSHAFT ADPT,IHC 885
11	06400307	1	SPACER,CRNKSHFT ADPT
12	24860	4	CAPSCREW,20mmx40mm(2.5P)
13	33880	22	FLATWASHER,3/4,GR 8
14	21732	4	CAPSCREW,1/2 X 1-3/4 NC
15	21725	6	HEX NUT,1/2 NC
16	06533004	4	FLATWASHER,1/2
	<b>06700090</b>	<b>AVAIL.</b>	<b>TANK,RES,JD6000,ASSY</b>
17	06380012	1	TANK,RES,JD60004WD(34GAL)
18	06505044	1	FLTR ASSY,IN-TANK CPLT,SAE10MP
19	21627	4	NYLOCK NUT,3/8 NC
20	06505067	1	SIGHT GAUGE,JD6000,TANK,34GAL
21	22018	2	FLATWASHER,1/2,WIDE
22	06410352	1	CHANNEL,MNT,TANK,TIE-BOLT
23	06380014	2	TIE BOLT,SIDE TANK,HYDRO
24	33764	2	FLATWASHER,5/8,GR 8,SAE
25	06505077	1	CAP,BREATHER,O-RING
26	6T0649	1	FILTER GAUGE
27	TF4888	1	STREET ELBOW,1/8 X 90
28	21833	4	CAPSCREW,3/4 X 2-1/4 NC
29	25341	4	CAPSCREW,20mmx70mm(2.5PITCH)
30	24860	4	CAPSCREW,20mmx40mm(2.5PITCH)
31	21825	6	HEX NUT,3/4 NC
32	22421	4	CAPSCREW,16MMX40MM(2.0 PITCH)
33	21832	2	CAPSCREW,3/4 X 2 NC
34	6T2260	4	CAPSCREW,7/16 X 1-1/2 CUTOFF
35	06537004	4	WASHER,NEOPRENE,.75x1.25x.19
36	24937	4	FLATWASHER,7/16
37	06410857	1	BRACKET
38	21631	2	CAPSCREW,3/8 x 1-1/4,NC
39	21625	2	NYLOCK NUT,3/8,NC
40	33764	4	FLATWASHER,5/8,SAE,GR8

# TRACTOR MOUNT KIT - HYDRAULICS 5101E

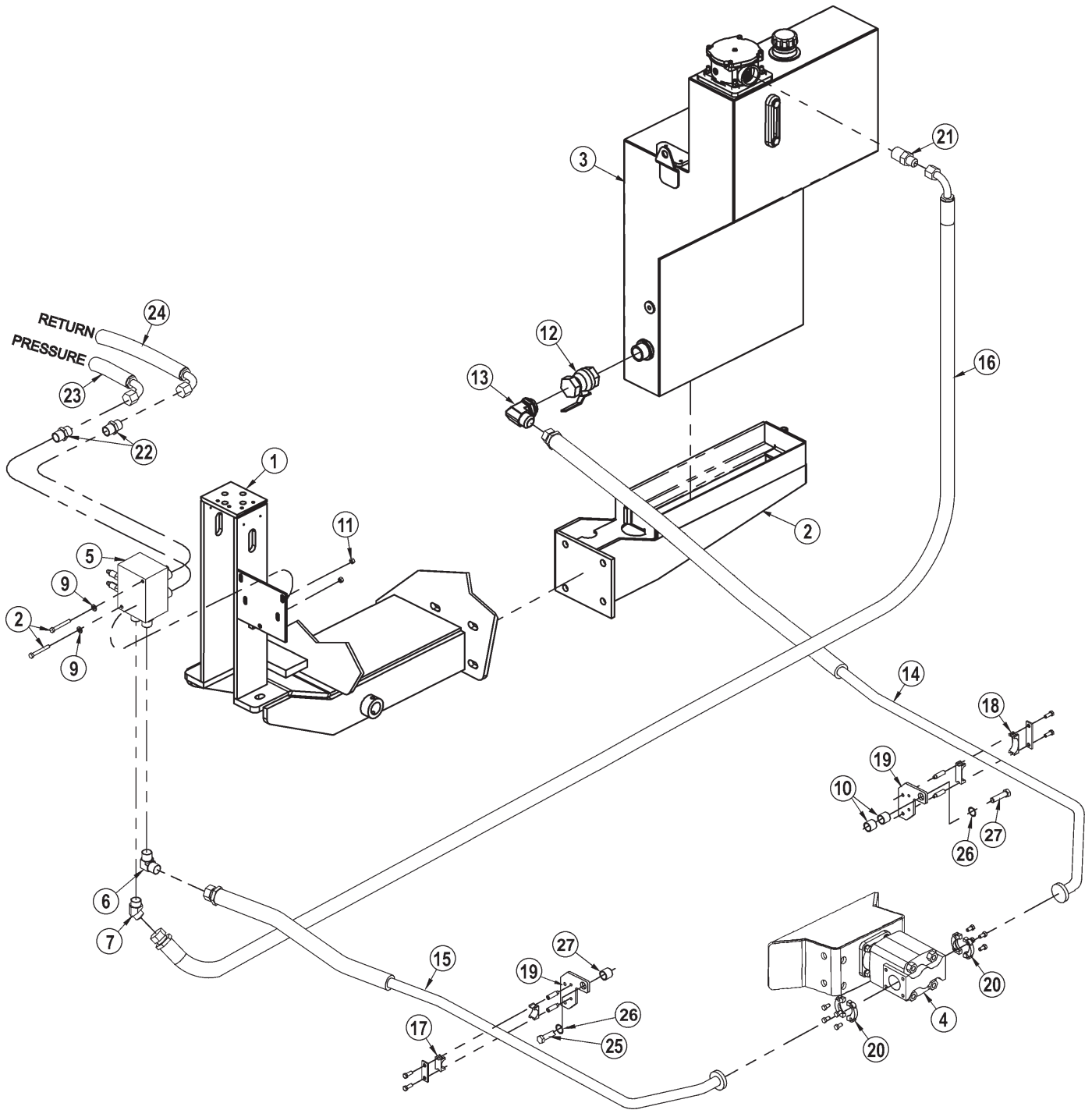

# TRACTOR MOUNT KIT - HYDRAULICS 5101E

ITEM	PART NO.	QTY.	DESCRIPTION
1	06300033	1	MAIN FRAME
2	06300088	1	MNT,HTDRO TANK,NHT6010
3	06700090	ASSY	HYDRAULIC TANK
4	23152	1	PUMP
5	06510083	1	SOLENOID BRAKE VALVE
6	34117	1	ELBOW 1"MORB X 1"MORB90
7	33554	1	ELBOW 1"MORB X MJIC45
8	21644	2	CAPSCREW - 3/8" X 5"
9	22016	2	FLATWASHER - 3/8"
10	30255	3	SPACER,1-1/4OD X 3/4ID X 3/4
11	21627	2	NYLOCK NUT,3/8 NC
12	34309	1	BALL VALVE,1 1/2 FOR
13	34655	1	ELBOW,1 1/2 ORB x 1 1/2 MJ
14	06506039	1	HOSE/TUBE,#24 x 65(24FJX x 20FL)
15	06506023	1	HOSE/TUBE ,1 x 62(20FLG x 1FJX)
16	06500398	1	HOSE,#16x114(16FJXx16FJX90)
17	34076	1	CLAMP KIT - 1"
18	06505017	1	CLAMP KIT - 1-1/4"
19	34626	2	TUBE / CLAMP BRACKET
20	TF4852	2	FLANGE KIT - #20
21	34064	1	ADAPTER - 1-1/4" X 1"
22	33555	2	ADAPTER 1"MORB X 1"MJIC
23		1	HOSE (PRESSURE)
24		1	HOSE (RETURN)
25	22421	2	CAPSCREW, 16MM X 40MM
26	31732	1	CAPSCREW, 16MM X 70MM
**	<b>6T3200</b>	<b>8</b>	<b>SPLIT HOSE (NOT SHOWN)</b>
**	<b>6T1823</b>	<b>24</b>	<b>ZIP TIE (NOT SHOWN)</b>
**	<b>6T1822</b>	<b>14</b>	<b>ZIP TIE (NOT SHOWN)</b>

**NOTE:** Band hoses together with zip ties wherever loose. Where hoses may contact the frame or other edges, wrap with split hose and secure with hose clamps or zip ties.

# TRACTOR MOUNT KIT - MAIN FRAME 5101E - LOADER

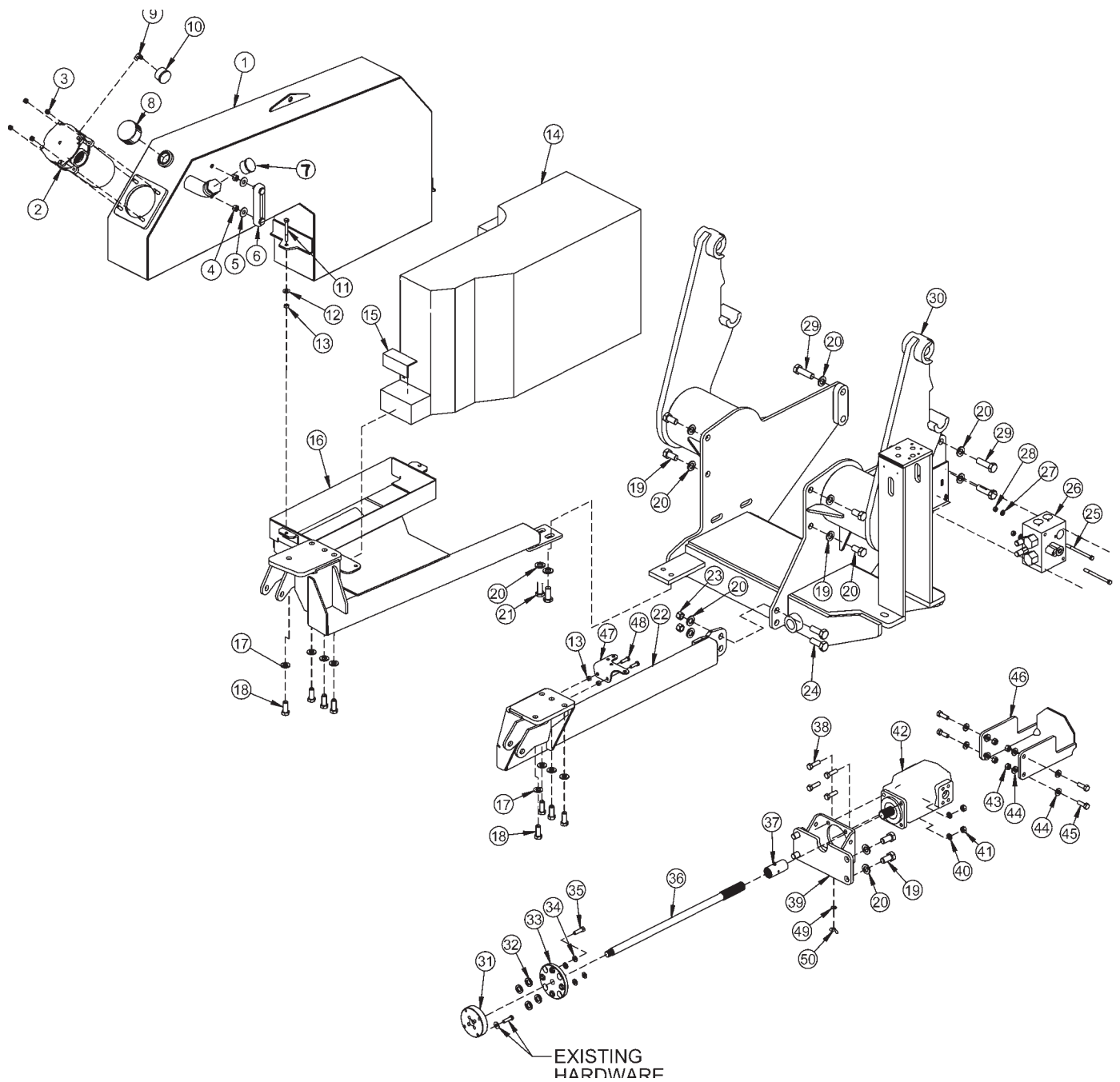

# TRACTOR MOUNT KIT - MAIN FRAME 5101E - LOADER

ITEM	PART NO.	QTY.	DESCRIPTION
*	<b>06700091</b>	<b>AVAIL.</b>	<b>TANK,RES,ASSY,WHEEL WELL</b>
1	06380015	1	TANK,RES,WHEEL WELL
2	06505044	1	FILTER ASSY,IN-TANK CPLT,SAE10,MP
3	21627	4	NYLOCK NUT,3/8,NC
4	21725	2	HEX NUT,1/2,NC
5	22018	2	FLATWASHER,1/2,WIDE
6	06505067	1	SIGHT GAGE
7	06505127	1	PLUG,SAE #20
8	06505077	1	CAP,BREATHER
9	TF4888	1	STREET ELBOW,1/8
10	6T0649	1	FILTER GAGE
11	21639	2	CAPSCREW,3/8 x 3-1/4,NC
12	22016	2	FLATWASHER,3/8
13	21627	4	NYLOCK NUT,3/8,NC
14	*	*	JD FUEL TANK
15	6T3200	1	SPLIT HOSE
16	06300108	1	AXLE BRC,LH,5101E,LDR
17	33764	8	FLATWASHER,5/8,GR8,SAE
18	22421	8	CAPSCREW,16MM x 200MM,(2.0P)8.8
19	24860	8	CAPSCREW,20MM x 40MM,(2.5P)10.9
20	33880	16	FLATWASHER,3/4,GR 8,SAE
21	21831	2	CAPSCREW, 3/4 X 1 3/4,NC
22	06300035	1	AXLE BRACE,JD5525,RH
23	21825	2	HEX NUT,3/4,NC
24	21833	2	CAPSCREW,3/4 x 2-1/4,NC
25	21644	2	CAPSCREW,3/8 x 5,NC
26	06510083	1	VALVE,BRAKE,SOL,3000PSI
27	21988	2	LOCKWASHER,3/8
28	21625	2	HEX NUT,3/8,NC
29	25341	4	CAPSCREW,20MM x 70MM,(2.5P)
30	06300107	1	MNFRM,JD5101E,553LDR
31	06400307	1	SPACER,CRNKSHFT ADPTR
*	<b>6T0389</b>	<b>AVAIL.</b>	<b>CRANKSHAFT ADPT,IHC 885</b>
32	06537004	4	WASHER,NEOPRENE,.75 x 1.25 x .19
33	31674	1	CRANKSHAFT ADPT PLATE
34	24937	4	FLATWASHER,7/16
35	6T2260	4	CAPSCREW,7/16 x 1-1/2,NC
36	06420126	1	DRIVESHAFT,PUMP
37	06700133	1	COUPLER,14SPLINE,LDR
38	21732	4	CAPSCREW,1/2 x 1-3/4,NC
39	06380033	1	MNT,PUMP,5101E,LDR
40	06533004	4	FLATWASHER,1/2
41	21725	4	HEX NUT,1/2 NC
42	23152	1	PUMP,P350-1-3/4 GEAR
*	<b>06200709</b>	<b>AVAIL.</b>	<b>PUMP GUARD KIT,JD5101E</b>
43	21727	4	NYLOCK NUT,1/2,NC
44	06533004	8	FLATWASHER,1/2,SAE
45	21731	4	CAPSCREW,1/2 x 1-1/2,NC
46	06380034	1	GUARD,PUMP,5101E,LDR
47	06410857	1	MNT,SPPRT,HYDRO
48	21631	2	CAPSCREW,3/8 x 1-1/4,NC
49	22014	1	FLATWASHER,1/4
50	32519	1	WING NUT,1/4-20 UNC

# TRACTOR MOUNT KIT - HYDRAULICS 5101E - LOADER

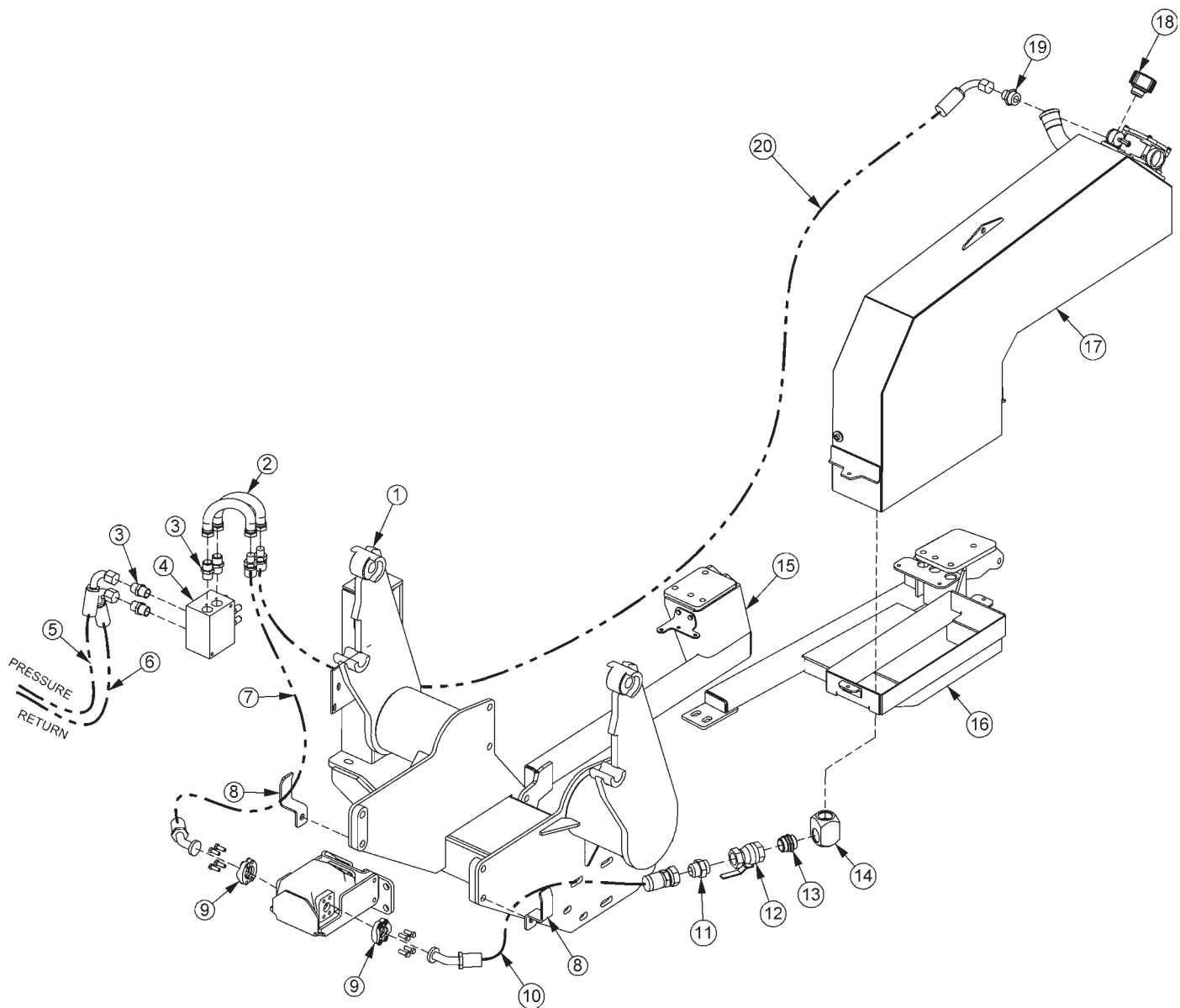



# TRACTOR MOUNT KIT - HYDRAULICS 5101E - LOADER

ITEM	PART NO.	QTY.	DESCRIPTION
1	*	REF	REFER TO MAIN FRAME PARTS
2	06506012	2	PRFRMD TUBE
3	33555	4	ADAPTER,1MORBX1MJIC
4	*	REF	REFER TO MAIN FRAME PARTS
5	*	1	1" HOSE
6	*	1	1" HOSE
7	06500407	1	HOSE, 1x92
8	32382	2	HOSE BRACKET
9	TF4852	2	FLANGE KIT,#20
10	06500408	1	HOSE, 1-1/2x92
11	34710	1	ADAPTER,1-1/2ORB x 1-1/2MJ
12	34309	1	BALL VALVE,1-1/2
13	06503083	1	ADAPTER,1-1/2ORB x 1-1/2ORB
14	06503084	1	ELBOW,1-1/2FOR X 1-1/2FOR
15	*	REF	REFER TO MAIN FRAME PARTS
16	*	REF	REFER TO MAIN FRAME PARTS
17	*	REF	REFER TO MAIN FRAME PARTS
18	06505077	1	BREATHER CAP,O-RING
19	34064	1	ADAPTER,1-1/4MOR X 1MJ
20	06500422	1	HOSE, 1x126

# TRACTOR MOUNT KIT - WHEEL WELL TANK

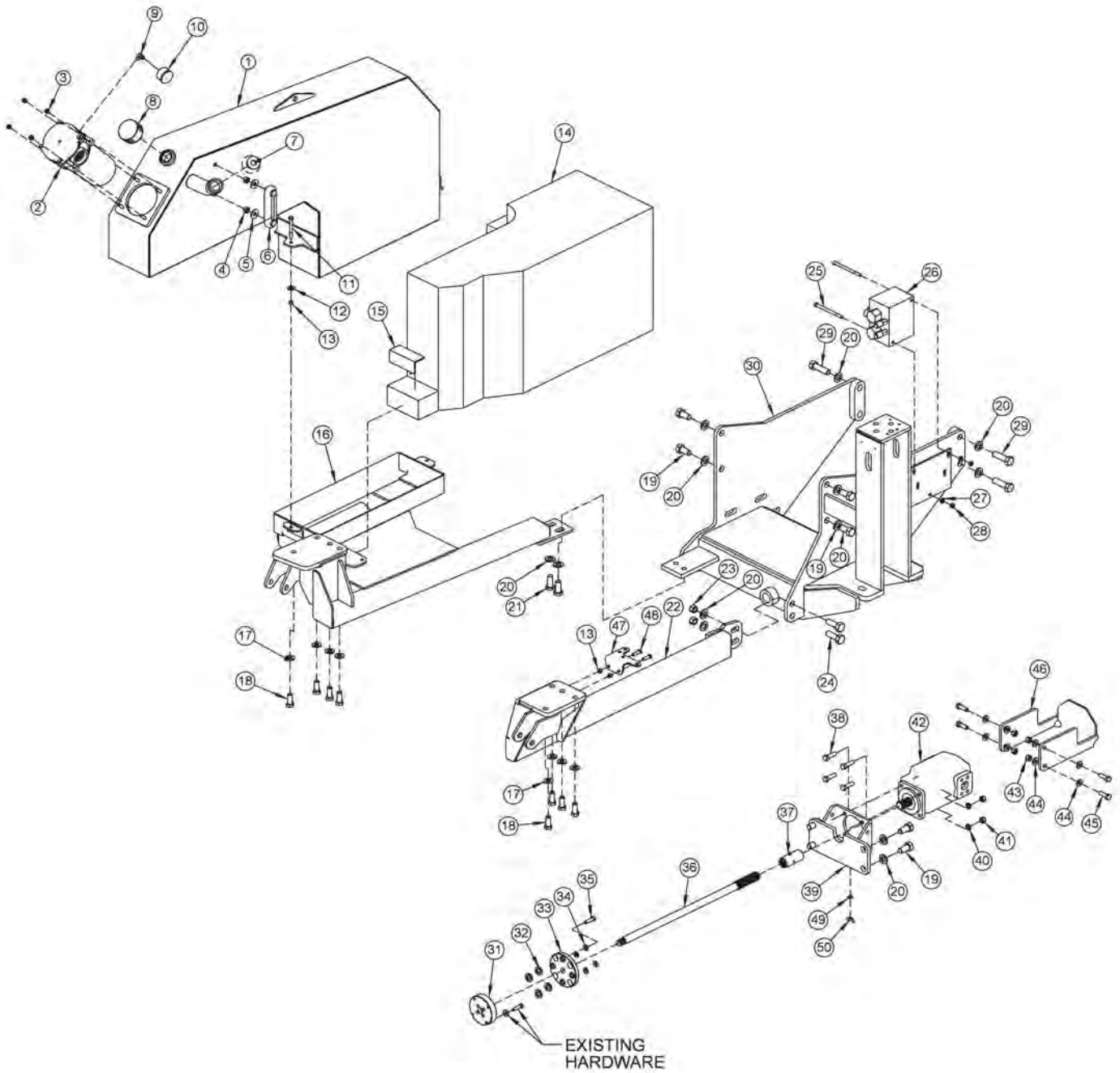

# TRACTOR MOUNT KIT - WHEEL WELL TANK

ITEM	PARTNO.	QTY.	DESCRIPTION
*	<b>06700091</b>	<b>AVAIL.</b>	<b>TANK,RES,ASSY,WHEEL WELL</b>
1	06380015	1	TANK,RES,WHEEL WELL
2	06505044	1	FILTER ASSY,IN-TANK CPLT,SAE10,MP
3	21627	4	NYLOCK NUT,3/8,NC
4	21725	2	HEX NUT,1/2,NC
5	22018	2	FLATWASHER,1/2,WIDE
6	06505067	1	SIGHT GAGE
7	06505127	1	PLUG,SAE #20
8	06505077	1	CAP,BREATHER
9	TF4888	1	STREET ELBOW,1/8
10	6T0649	1	FILTER GAGE
11	21639	2	CAPSCREW,3/8 x 3-1/4,NC
12	22016	2	FLATWASHER,3/8
13	21627	4	NYLOCK NUT,3/8,NC
14	*	*	JD FUEL TANK
15	6T3200	1	SPLIT HOSE
16	06300108	1	AXLE BRC,LH,5101E,LDR
17	33764	8	FLATWASHER,5/8,GR8,SAE
18	22421	8	CAPSCREW,16MM x 200MM,(2.0P)8.8
19	24860	8	CAPSCREW,20MM x 40MM,(2.5P)10.9
20	33880	16	FLATWASHER,3/4,GR 8,SAE
21	21831	2	CAPSCREW, 3/4 X 1 3/4,NC
22	06300035	1	AXLE BRACE,JD5525,RH
23	21825	2	HEX NUT,3/4,NC
24	21833	2	CAPSCREW,3/4 x 2-1/4,NC
25	21644	2	CAPSCREW,3/8 x 5,NC
26	06510083	1	VALVE,BRAKE,SOL,3000PSI
27	21988	2	LOCKWASHER,3/8
28	21625	2	HEX NUT,3/8,NC
29	25341	4	CAPSCREW,20MM x 70MM,(2.5P)
30	06300033	1	MNFRM,JD5101E
31	06400307	1	SPACER,CRNKSHFT ADPTR
*	<b>6T0389</b>	<b>AVAIL.</b>	<b>CRANKSHAFT ADPT,IHC 885</b>
32	06537004	4	WASHER,NEOPRENE,.75 x 1.25 x .19
33	31674	1	CRANKSHAFT ADPT PLATE
34	24937	4	FLATWASHER,7/16
35	6T2260	4	CAPSCREW,7/16 x 1-1/2,NC
36	06520330	1	DRIVESHAFT,PUMP
37	6T0375B	1	COUPLER,14SPLINE
38	21732	4	CAPSCREW,1/2 x 1-3/4,NC
39	32642	1	MNT,PUMP
40	06533004	4	FLATWASHER,1/2
41	21725	4	HEX NUT,1/2 NC
42	23152	1	PUMP,P350-1-3/4 GEAR
*	<b>06200709</b>	<b>AVAIL.</b>	<b>PUMP GUARD KIT,JD5101E</b>
43	21727	4	NYLOCK NUT,1/2,NC
44	06533004	8	FLATWASHER,1/2,SAE
45	21731	4	CAPSCREW,1/2 x 1-1/2,NC
46	06380034	1	GUARD,PUMP,5101E,LDR
47	06410857	1	MNT,SPPRT,HYDRO
48	21631	2	CAPSCREW,3/8 x 1-1/4,NC
49	22014	1	FLATWASHER,1/4
50	32519	1	WING NUT,1/4-20 UNC

# TRACTOR MOUNT KIT - HYDRO, WHEEL WELL TANK

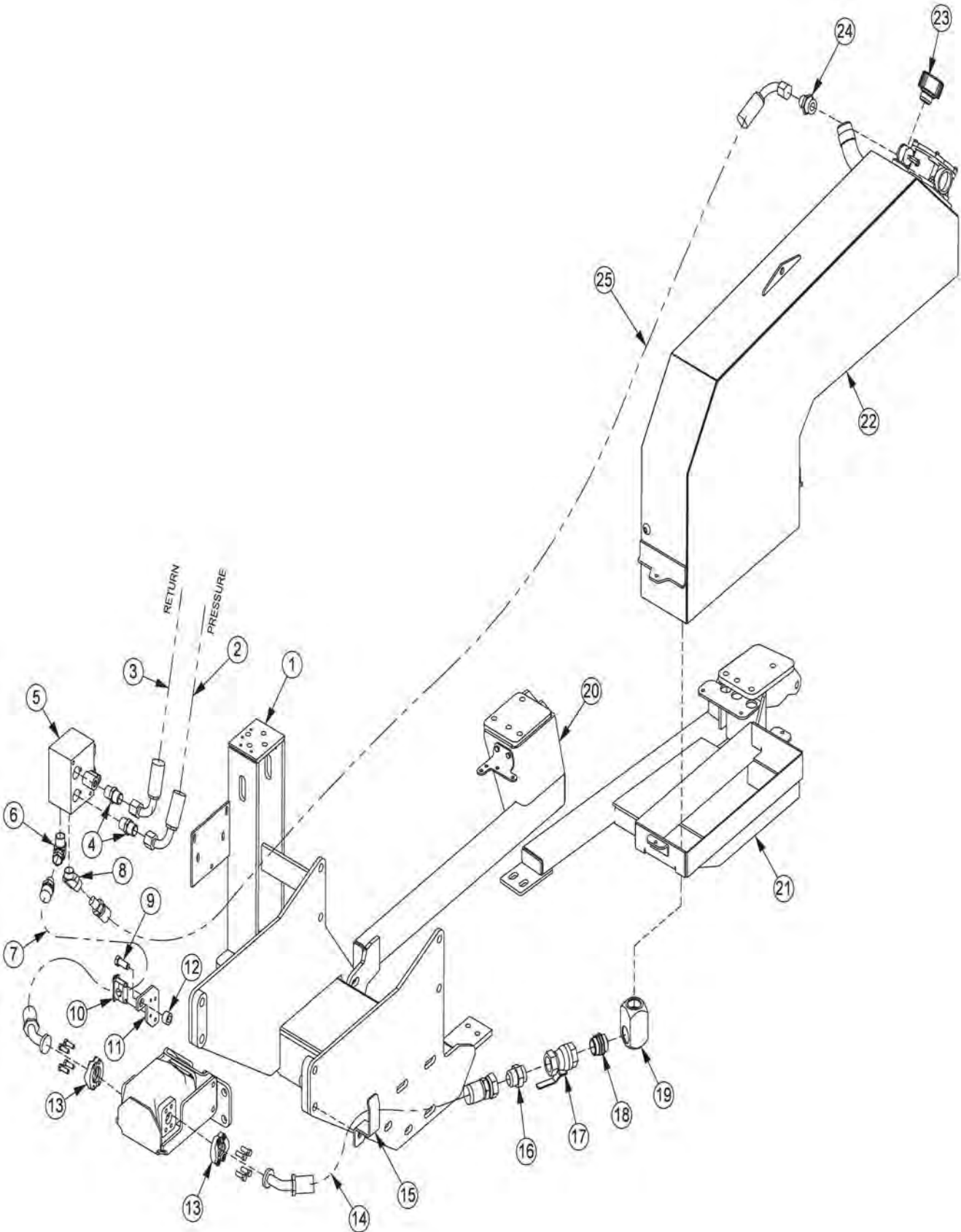

# TRACTOR MOUNT KIT - HYDRO, WHEEL WELL TANK

ITEM	PART NO.	QTY.	DESCRIPTION
1	06300033	1	MAIN FRAME
2	*	1	1" HOSE
3	*	1	1" HOSE
4	33555	2	ADAPTER,1MORB x 1MJIC
5	*	<b>REF</b>	<b>BRAKE VALVE - REFER TO MAIN FRAME PARTS</b>
6	34117	1	ELBOW,1MORB x 1MORB90
7	06506023	1	HOSE/TUBE,1 x 62"
8	33554	1	ELBOW,1MORB x 1MJIC45
9	22421	1	CAPSCREW,16MM x 40MM
10	34076	1	CLAMP KIT,1"
11	34626	1	TUBE/CLAMP BRACKET
12	30255	1	SPACER
13	TF4852	2	FLANGE KIT,#20
14	06500408	1	HOSE,1-1/2 x 92"
15	32382	1	HOSE BRACKET
16	34710	1	ADAPTER,1-1/2ORB x 1-1/2MJ
17	34309	1	BALL VALVE,1-1/2"
18	06503083	1	ADAPTER,1-1/2ORB x 1-1/2ORB
19	06503084	1	ELBOW,1-1/2FOR x 1-1/2FOR
20	*	<b>REF</b>	<b>AXLE BRACE,RH - REFER TO MAIN FRAME PARTS</b>
21	*	<b>REF</b>	<b>AXLE BRACE,LH - REFER TO MAIN FRAME PARTS</b>
22	*	<b>REF</b>	<b>TANK,ASSY - REFER TO MAIN FRAME PARTS</b>
23	06505077	1	BREATHER CAP,O-RING
24	34064	1	ADAPTER,1-1/4MOR x 1MJIC
25	06500422	1	HOSE,1 x 126"

# BOOM MOUNT KIT - BOOM SWIVEL / BOOM REST

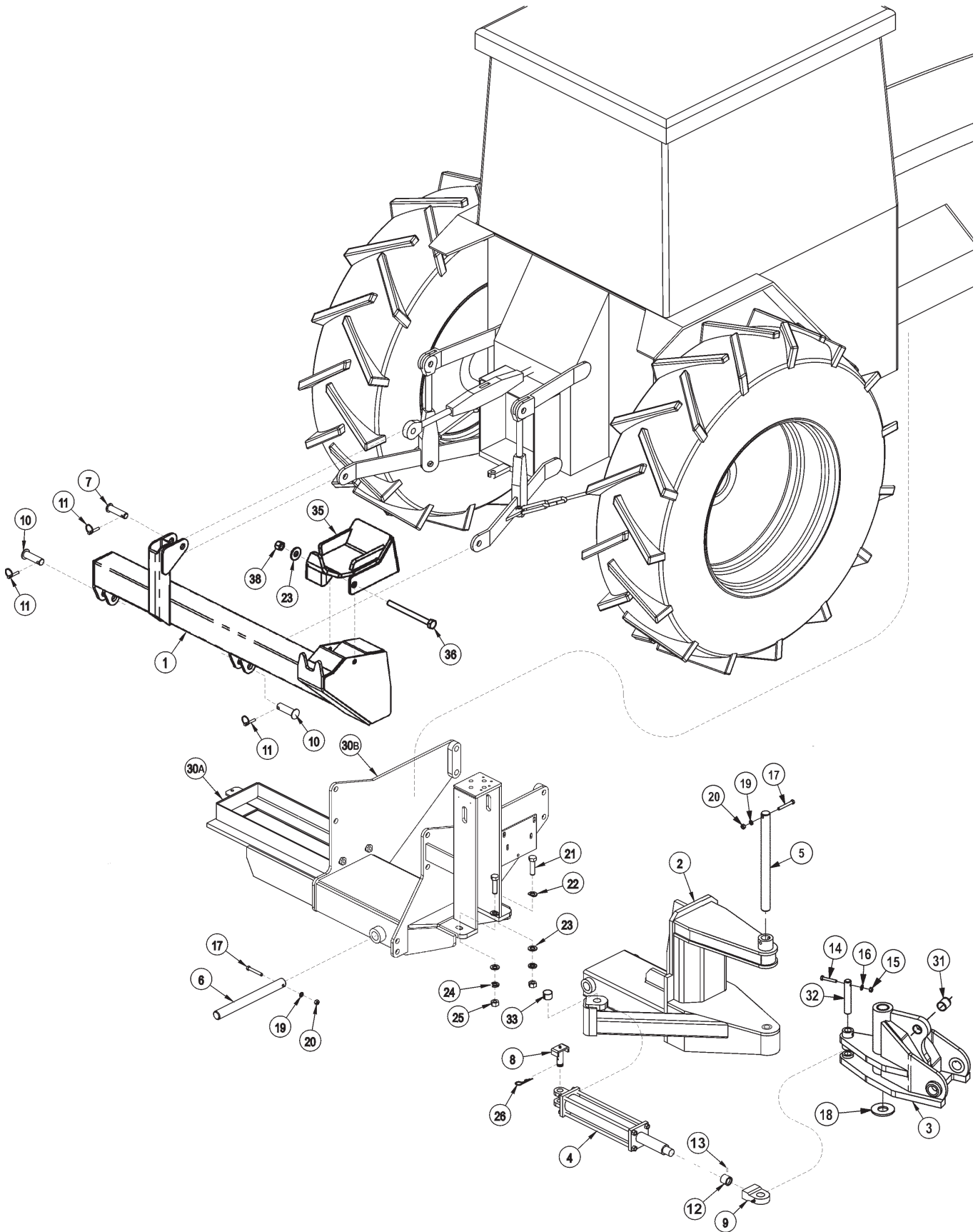



# BOOM MOUNT KIT - BOOM SWIVEL / BOOM REST

ITEM	PART NO.	QTY.	DESCRIPTION
1	06310023	1	BOOMREST,STD,3PNT
2	06310030	1	MNT BRKT,BOOM,GREASELESS,CHET
3	06700056	1	SWIVEL,ASSY,GREASELESS,CHET
4	34275	1	CYL,2 1/2X11 1/2,2500 PSI
5	06420013	1	PIN,1.5x18.88,W/.47 HOLE,NIT
6	6T3001	1	PIN,INNR DRFT BM 1-1/2X15-3/4
7	TB1036	1	PIN,SEC BOOM SWIV 1X4-11/16
8	TB1031	1	PIN,PVT ASSY 1 X 4 LOCKINGHEAD
9	TB3033	1	CLEVIS,W/SPHERICAL BEARING
10	TF1120	2	PIN,(CAPPED),1-1/8 X 3-7/8
11	TF1143	3	PIN,LYNCH 7/16 X 2
12	06420114	1	SPACER,2.25x1.25x1.38,TAPPED
13	6T2272	1	SETSCREW,3/8 X 1/2 NC
14	21635	1	CAPSCREW,3/8 X 2-1/4 NC
15	21627	1	NYLOCK NUT,3/8 NC
17	21688	2	CAPSCREW,7/16 X 3-1/4 NC
18	06520049	1	BEARING,WASHER,SWING
20	21677	3	NYLOCK NUT,7/16 NC
21	21835	2	CAPSCREW,3/4 X 2-3/4 NC
22	6T2607	2	FLATWASHER,3/4,CUT
23	22021	3	FLATWASHER,3/4
24	21993	2	LOCKWASHER,3/4,GR 8
25	21825	2	HEX NUT,3/4 NC
26	6T3004	1	R-CLIP(HAIRPIN COTTER,3/16)
30A	*	REF	REFER TO MAIN FRAME PARTS
30B	*	REF	REFER TO MAIN FRAME PARTS
31	06499004	1	BEARING,.1.5x1.25x1,COMP
32	33464	1	PIN,1.00 x 5.63, W/HOLE
33	TB3010	1	BUSHING,1
35	06310027	1	BOOMREST,CHET,3PNT
36	21846	1	CAPSCREW,3/4 X 9 NC
38	21827	1	NYLOCK NUT,3/4 NC

# SWITCH BOX AND JOYSTICK 5101E

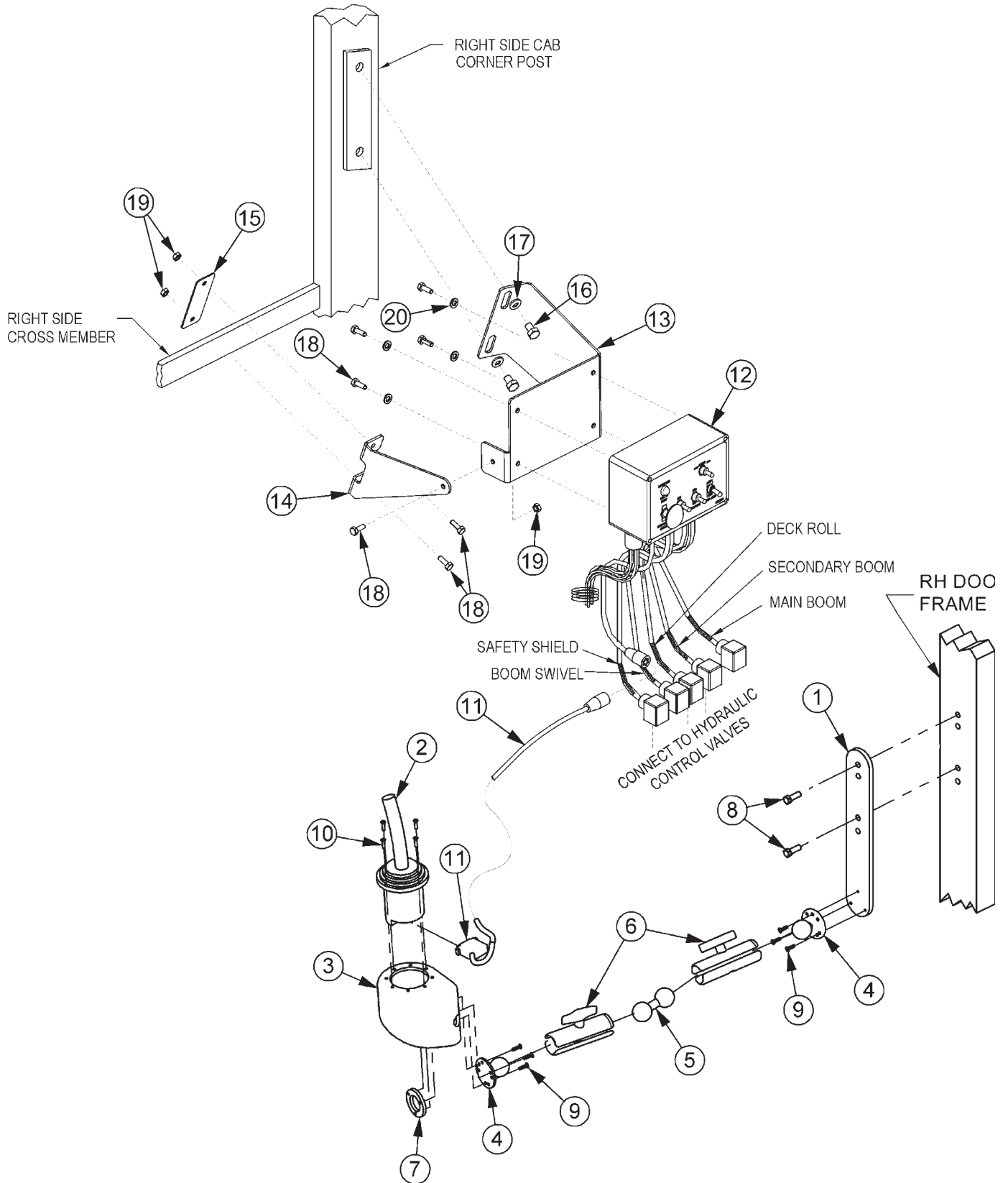

## SWITCH BOX AND JOYSTICK 5101E

ITEM	PART NO.	QTY.	DESCRIPTION
1	06340031	1	MT,BRKT,JYSTK,JD5101E
2	33691	1	JOYST,4AXIS,RH,DF,W/SUB-D CONN
3	06770022	1	CAN,JYSTK,TRUCKAT,4WD
4	06520019	2	MOUNT,RAM BALL,1 1/2",FLANGE
5	06520290	1	MOUNT,RAM,BALL,DBL,1 1/2
6	06520020	2	MOUNT,RAM,ARM,1 1/2x4 5/8,STD
7	06400882	1	RING,BOLT,MNT,JYSTK
8	23113	2	CAPSCREW,10MMX30MM(1.5 PITCH)
9	32990	6	SCREW,MACHINE,10-32X1/2,RD HD
10	32829	4	SCREW,MACHINE,10-32X3/4,FLATHD
11	33693	1	CBL,EXT,4FT,JOYST,W/SUB-D CONN
12	06510196	1	SWITCHBOX,DF,BOOM,PVEA
13	34264	1	SWITCHBOX MOUNT,JD5520
14	34265	1	SWITCHBOX BRACE,JD5520
15	34266	1	SWITCHBOX STRAP,JD5520
16	25188	2	CAPSCREW,10MMX15MM(1.5 PITCH)
17	22016	2	FLATWASHER,3/8,GR8
18	21529	7	CAPSCREW,1/4 X 3/4 NC
19	21527	3	NYLOCK NUT,1/4 NC
20	21986	4	LOCKWASHER,1/4

# LIFT VALVE - JOYSTICK CONTROL

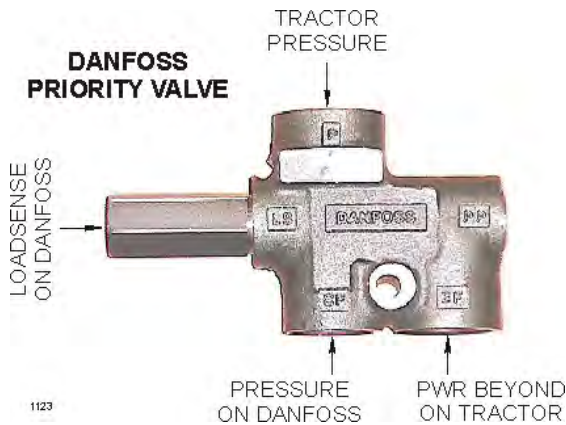

1123

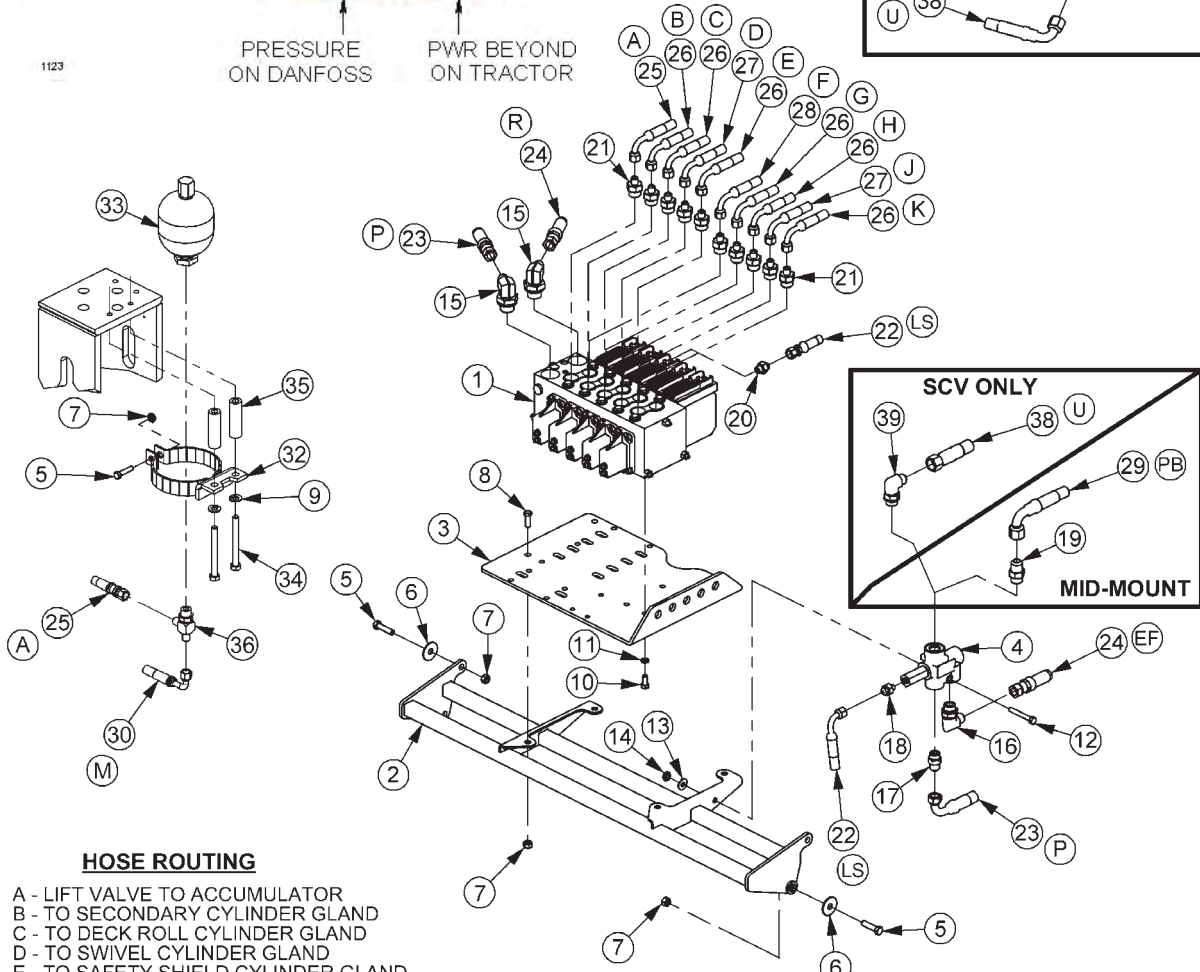
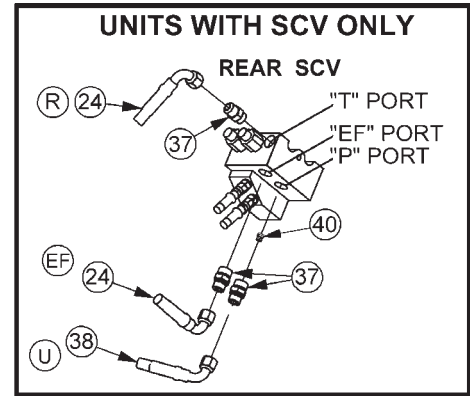

**HOSE ROUTING**

- A - LIFT VALVE TO ACCUMULATOR
- B - TO SECONDARY CYLINDER GLAND
- C - TO DECK ROLL CYLINDER GLAND
- D - TO SWIVEL CYLINDER GLAND
- E - TO SAFETY SHIELD CYLINDER GLAND
- F - TO MAIN BOOM CYLINDER BUTT
- G - TO SECONDARY CYLINDER BUTT
- H - TO DECK ROLL CYLINDER BUTT
- J - TO SWIVEL CYLINDER BUTT
- K - TO SAFETY SHIELD CYLINDER BUTT
- M - TO MAIN BOOM CYLINDER GLAND
- EF - "EF" PORT OF PRIORITY VALVE TO "EF" RETURN PORT OF TRACTOR
- LS - "LS" PORT ON PRIORITY VALVE TO "LS" PORT ON LIFT VALVE
- P - "CF" PORT ON PRIORITY VALVE TO "P" PORT ON LIFT VALVE
- R - "T" PORT ON LIFT VALVE TO RETURN PORT ON TRACTOR

PB - MID-MOUNT VALVE "PB" PORT TO "P" PORT OF PRIORITY VALVE	<b>MID-MOUNT VALVES</b>
U - "P" PORT OF REAR SCV TO "P" PORT OF PRIORITY VALVE	<b>SCV ONLY</b>

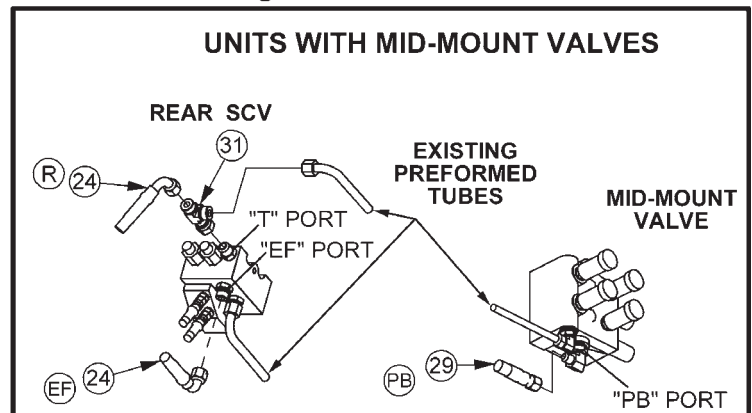
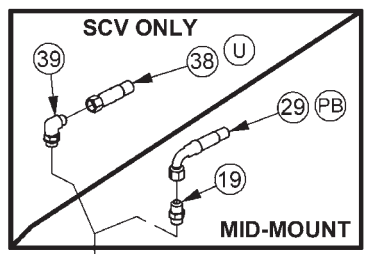

# LIFT VALVE - JOYSTICK CONTROL

ITEM	PART NO.	QTY.	DESCRIPTION
1	06502095	1	VALVE,5SP,DANFOSS
2	06340017	1	VALVE MNT
3	34622	1	PLATE,VALVE,REAR MNT
4	06502102	1	VALVE,PRIORITY,DF OLS80,10 BAR
5	21632	5	CAPSCREW,3/8 X 1-1/2 NC
6	6T2615	4	WASHER,FENDER 3/8
7	21627	9	NYLOCK NUT,3/8 NC
8	21630	4	CAPSCREW,3/8 X 1 NC
9	21988	2	LOCKWASHER,3/8
10	21579	4	CAPSCREW,5/16 X 3/4 NC
11	21987	4	LOCKWASHER,5/16
12	21585	1	CAPSCREW,5/16 X 2-1/4 NC
13	22015	1	FLATWASHER,5/16
14	21577	1	NYLOCK NUT,5/16 NC
15	33294	2	ELBOW,3/4MOR X 1/2MJIC 90
16	33383	1	ELBOW,5/8MORB X 1/2MJ X 90
17	33528	1	ADAPTER,1/2MORBx1/2MJIC
18	06503057	1	ADAPTER,1/4ORBx3/8MJ
19	06503036	1	ADAPTER,5/8ORBx5/8MJ
20	33392	1	ADAPTER,5/16MORB X 3/8MJ
21	32807	10	ADAPTER,5/8MORB X 3/8MJ
22	06500219	1	HOSE,#6x48(6FJXx6FJX90)
23	06500171	1	HOSE,1/2x36(1/2FJX90x1/2FJX)
24	33566	2	HOSE,#8x35(10FFSX90x8FJX)
25	33562	1	HOSE,#4x130(6FJX90x6FJX)
26	34358	6	HOSE,#4x196(6FJX90x5MJ)
27	33364	2	HOSE,#4x120(6FJX90x6FJX)
28	06500164	1	HOSE,#4x216(6FJX90x6FJX)
29	06500390	1	HOSE#8x87(10FJX90x12FFSX)
30	33745	1	HOSE,#4x100(6FJX90x6FJX)
31	32872	1	SWIVEL NUT RUN TEE
32	23888	1	BRKT,ACCUMULATOR
33	33470	1	ACCUMULATOR
34	21641	2	CAPSCREW,3/8 X 3 3/4 NC
35	06420054	2	SPACER,75x41.x2.50
36	06503029	1	TEE,RUN,1/2ORBx3/8MJx3/8MJ
37	34424	3	FITTING,ADAPTER,22MMX5/8MFS
38	06500399	1	HOSE,#8x41(10FFSX90x10FJX)
39	06503033	1	ELBOW,5/8ORBx5/8MJ
40	31171	1	PLUG,PIPE 3/8 SKT

# CABLE CONTROLS - SCV ONLY

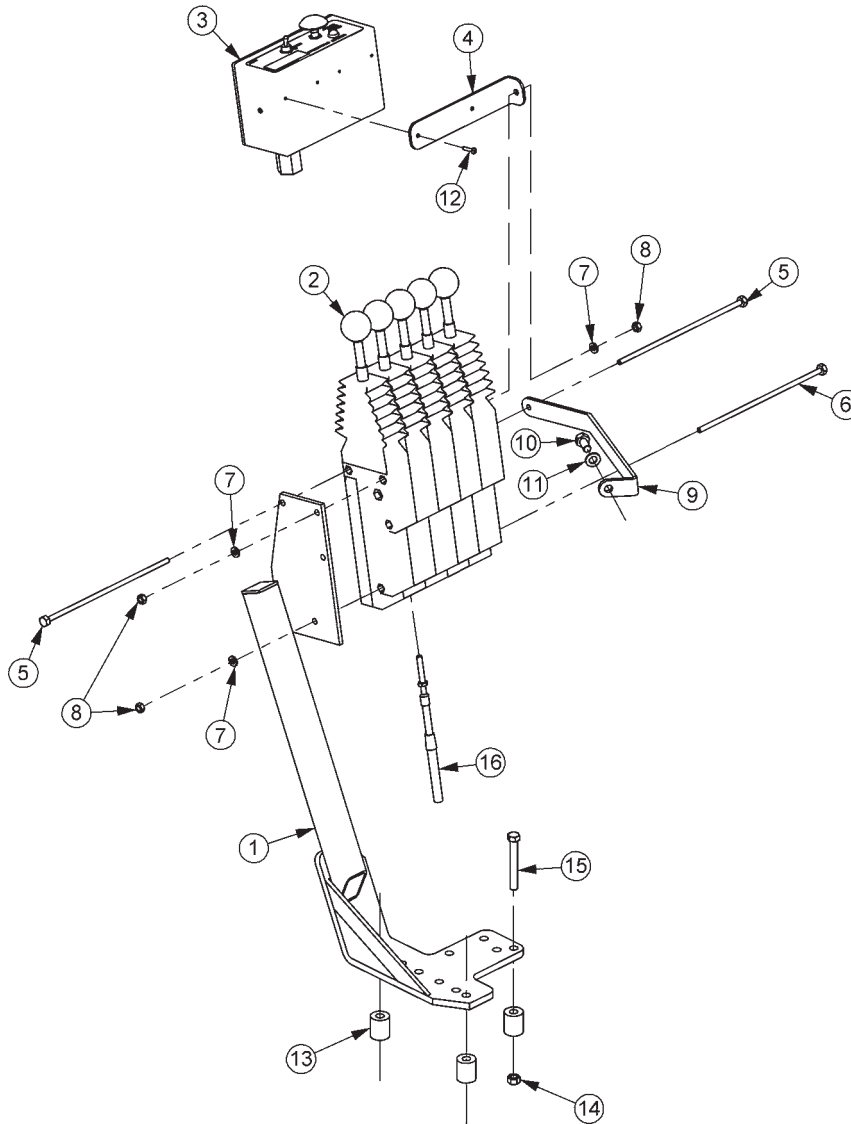

ITEM	PART NO.	QTY.	DESCRIPTION
1	23865B	1	CBL CTRL MT BRK,9030-FD40-JD60
2	6T1251	3	CBL CTRL BOX,180 DEG
3	06510100	1	SWITCHBOX,BOOM
4	34496	1	BRKT,SWITCHBOX,UNI
5	34332	1	CAPSCREW,1/4X9-1/4 NC
6	21548	1	CAPSCREW,1/4 X 9 NC
7	21986	3	LOCKWASHER,1/4
8	21525	3	HEX NUT,1/4 NC
9	06410230	1	SUPPORT,MNT,CNTRL BOX,JD5525
10	33534	1	CAPSCREW,10MMX20MM(1.5PITCH)
11	32724	1	FLATWASHER,10MM
12	6T3951	2	SCREW,MACHINE 8/32 X 1/2
13	27082B	3	SPACER
14	21627	3	NYLOCK NUT,3/8 NC
15	21636	3	CAPSCREW,3/8 X 2-1/2 NC
16	06505100	3	CBL,CNTRL,108



# CABLE CONTROLS - WITH MID-MOUNT VALVE

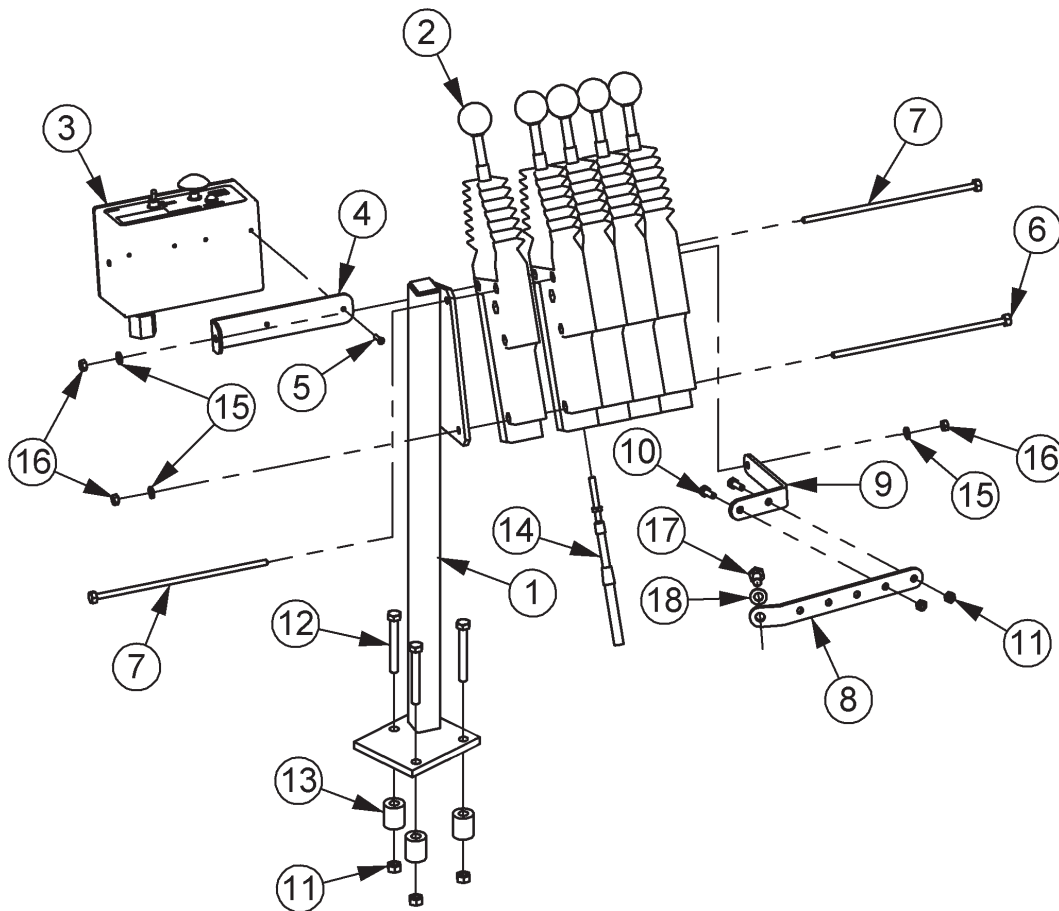

ITEM	PART NO.	QTY.	DESCRIPTION
1	31923	1	BRKT,CTRL,CBL,JD52-5500,CAB,
2	6T1251	5	CBL CTRL BOX,180 DEG
3	06510100	1	SWITCHBOX,BOOM
4	34496	1	BRKT,SWITCHBOX,UNI
5	6T3951	2	SCREW,MACHINE 8/32 X 1/2
6	21548	1	CAPSCREW,1/4 X 9 NC
7	34332	2	CAPSCREW,1/4X9-1/4 NC
8	06410848	1	SUPPORT,1,CBL,CNTRL,5101E
9	06410849	1	SUPPORT,2,CBL,CNTRL,5101E
10	21629	2	CAPSCREW,3/8 X 3/4 NC
11	21627	4	NYLOCK NUT,3/8 NC
12	21633	2	CAPSCREW,3/8x1 3/4,NC,GR8
13	27082B	2	SPACER
14	34623	5	CBL,CNTRL,122
15	21986	3	LOCKWASHER,1/4
16	21525	3	HEX NUT,1/4 NC
17	33534	1	CAPSCREW,10MMX20MM(1.5PITCH)
18	32724	1	FLATWASHER,10MM

# LIFT VALVE - CABLE CONTROL, CAB

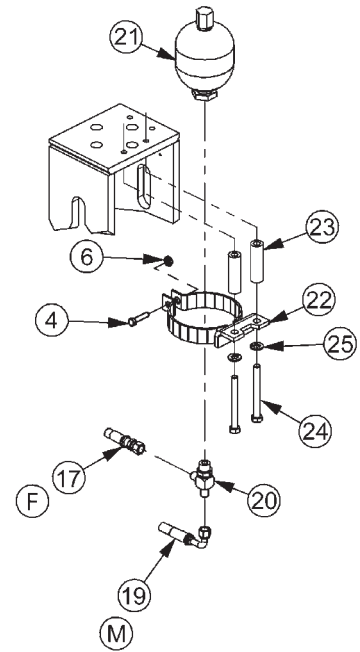
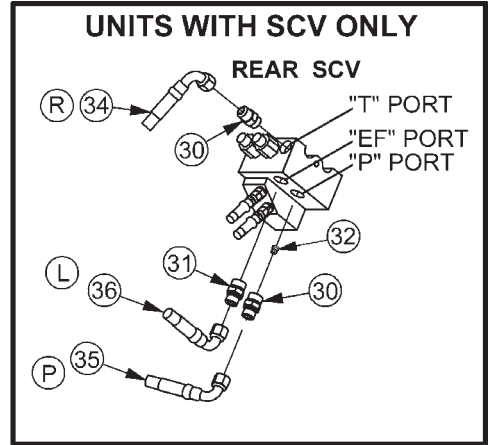
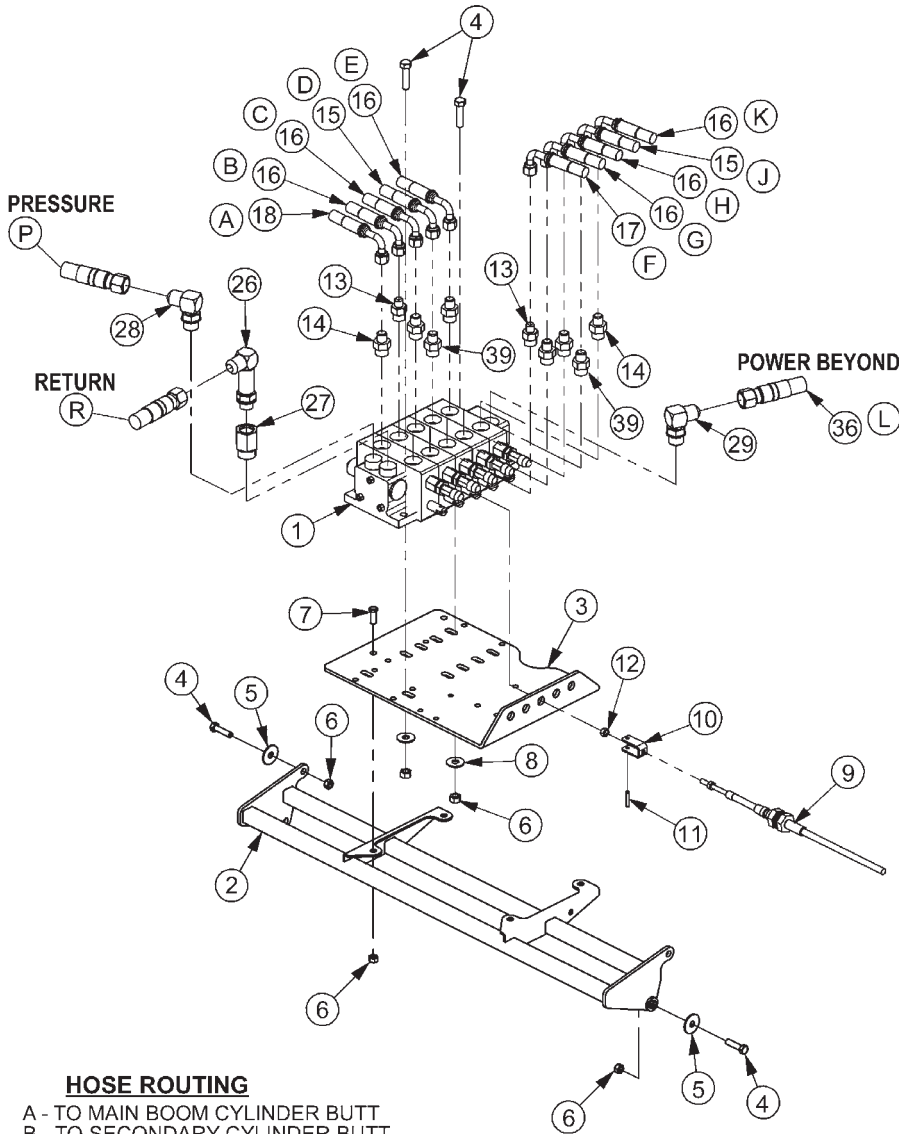

## HOSE ROUTING

- A - TO MAIN BOOM CYLINDER BUTT
- B - TO SECONDARY CYLINDER BUTT
- C - TO DECK ROLL CYLINDER BUTT
- D - TO SWIVEL CYLINDER BUTT
- E - TO SAFETY SHIELD CYLINDER BUTT
- F - LIFT VALVE TO ACCUMULATOR
- G - TO SECONDARY CYLINDER GLAND
- H - TO DECK ROLL CYLINDER GLAND
- J - TO SWIVEL CYLINDER GLAND
- K - TO SAFETY SHIELD CYLINDER GLAND
- L - "PB" PORT ON LIFT VALVE TO "EF" PORT ON TRACTOR
- M - TO MAIN BOOM CYLINDER GLAND
- P - "P" PORT ON LIFT VALVE TO "P" or "PB" PORT ON TRACTOR DEPENDING ON MODEL
- R - "T" PORT ON LIFT VALVE TO "T" PORT ON TRACTOR

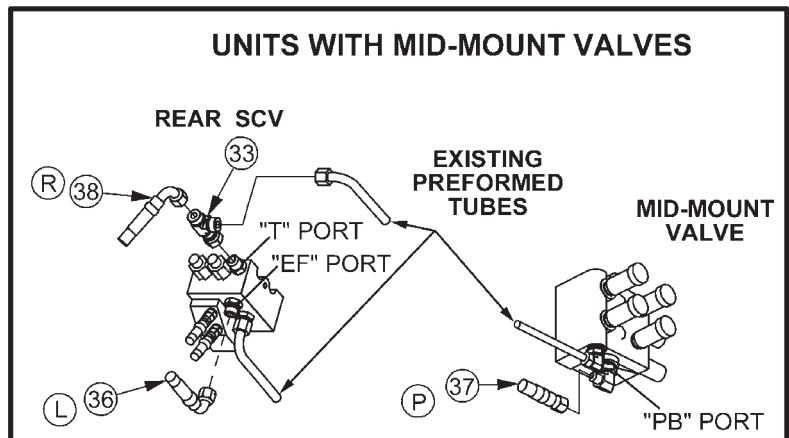

# LIFT VALVE - CABLE CONTROL, CAB

ITEM	PART NO.	QTY.	DESCRIPTION
1	33500	1	VALVE,5SP,HSC,TRB,PB
2	06340017	1	VALVE MNT
3	34622	1	PLATE,VALVE,REAR MNT
4	21632	9	CAPSCREW,3/8 X 1-1/2 NC
5	6T2615	4	WASHER,FENDER 3/8
6	21627	13	NYLOCK NUT,3/8 NC
7	21630	4	CAPSCREW,3/8 X 1 NC
8	22016	4	FLATWASHER,3/8
9	06505100	5	CBL,CNTRL,108
10	6T4411	5	CLEVIS,CBL CTRL,3/16
11	6T3017	5	ROLLPIN,3/16 X 1
12	21500	10	HEX NUT,1/4 NF
13	06502036	2	VLV,CHECK,W/.06 ORF,1/2MORx3/8
14	33271	6	ADAPTER,1/2 MOR X 3/8 MJ
15	33364	2	HOSE,1/4X120(3/8FJX90X3/8FJX)
16	34358	6	HOSE,1/4X196(3/8FJX90X5/16MJ)
17	21627	1	HOSE,1/4X128(3/8FJX90X3/8FJX)
18	06500164	1	HOSE,1/4X216(3/8FJX90X3/8FJX)
19	33745	1	HOSE,1/4X100(3/8FJX90X3/8FJX)
20	06503029	1	TEE,RUN,1/2ORBx3/8MJx3/8MJ
21	33470	1	ACCUMULATOR,30 CU IN.,1150 PSI
22	23888	1	BRKT,ACCUMULATOR
23	06420054	2	SPACER,75x41.x2.50
24	21641	2	CAPSCREW,3/8 X 3 3/4 NC
25	21988	2	LOCKWASHER,3/8
26	33293	1	ELBOW,LONG,1/2MOR X 1/2MJIC 90
27	32678	1	ADAPTER,5/8ORB x 1/2FOR
28	33383	1	ELBOW,5/8MORB X 1/2MJ X 90
29	06503033	1	ELBOW,5/8ORBx5/8MJ
30	33463	2	ADAPTER,22mm ORB x 1/2MJ
31	34424	1	FITTING,ADAPTER,22MMX5/8MFS
32	31171	1	PLUG,PIPE 3/8 SKT
33	32872	1	SWIVEL NUT RUN TEE
34	33486	1	HOSE,#8x45(8FJX90x8FJX)
35	33595	1	HOSE,#8x65(8FJX90x8FJX)
36	06500399	1	HOSE,#8x41(10FFSX90x10FJX)
37	06500391	1	HOSE,#8x97(12FFSXx8FJX)
38	06500392	1	HOSE,#8x62(10FFSX90x8FJX)
39	34396	2	ADAPTER,.06 RSTRCTR,1/2ORBx3/8MJ

# POLYCARBONATE SAFETY WINDOW - 5101E, CAB

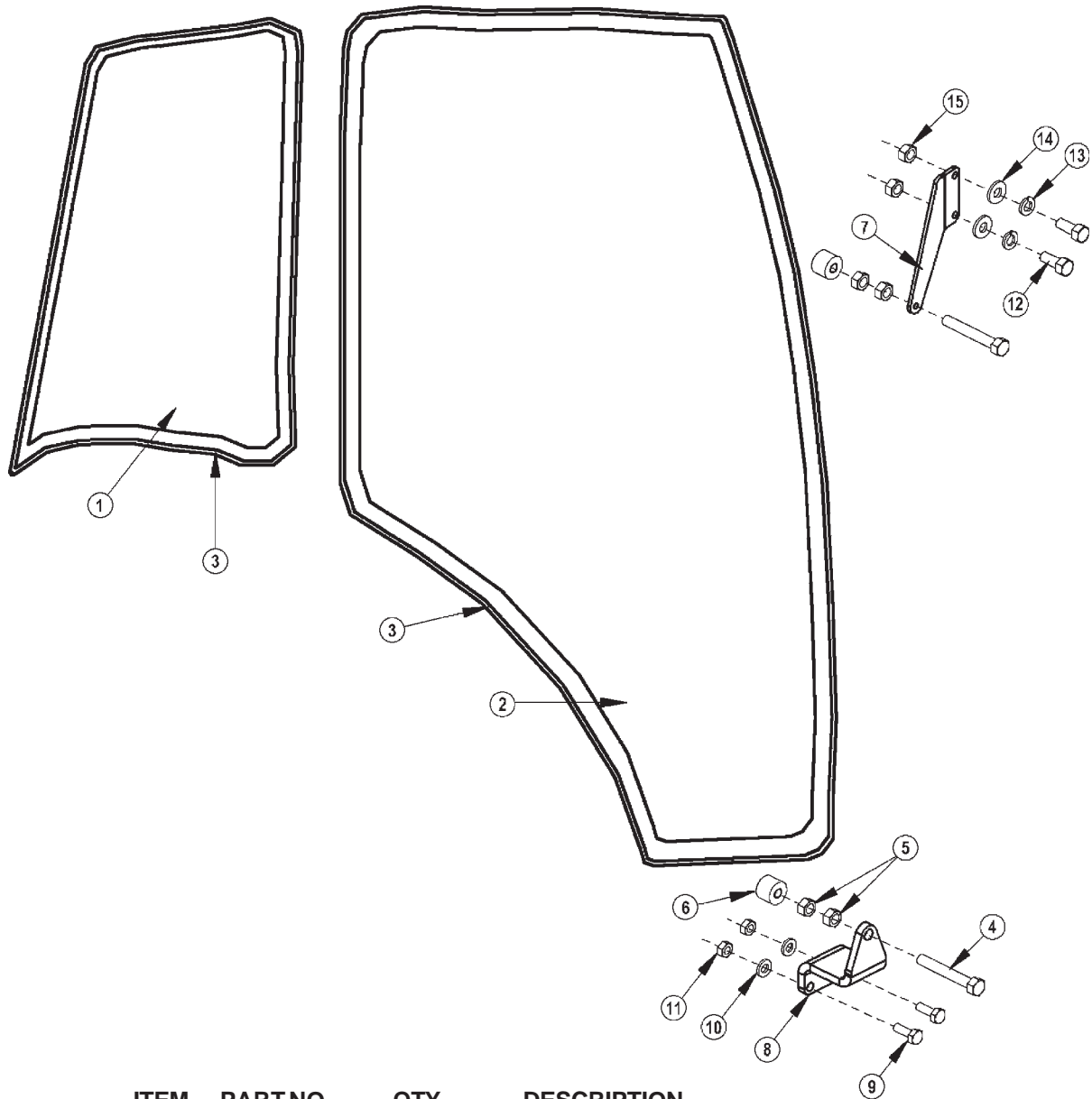

ITEM	PART NO.	QTY.	DESCRIPTION
1	06490014	1	POLYCARB, FRMD, REAR
2	06490013	1	POLYCARB, FRMD, DOOR
3	31965	25'	TRIMSEAL
4	21584	2	CAPSCREW, 5/16" X 2"
5	21575	6	HEX NUT, 5/16" NC
6	33477	2	VIBRATION ISOLATOR
7	06410268	1	TOP BRACKET
8	06410269	1	BOTTOM BRACKET
9	21529	2	CAPSCREW, 1/4" X 3/4" NC
10	21986	2	LOCKWASHER, 1/4"
11	21525	2	HEX NUT, 1/4" NC
12	27508	2	CAPSCREW, 8MM X 20MM (1.25)
13	6T2619	2	LOCKWASHER, 8MM
14	34948	2	WASHER, 8MM
15	*	2	HEX NUT (EXISTING HARDWARE)
	06537005	1	3M ADHESIVE

# SOLENOID VALVE SWITCH AND WIRING

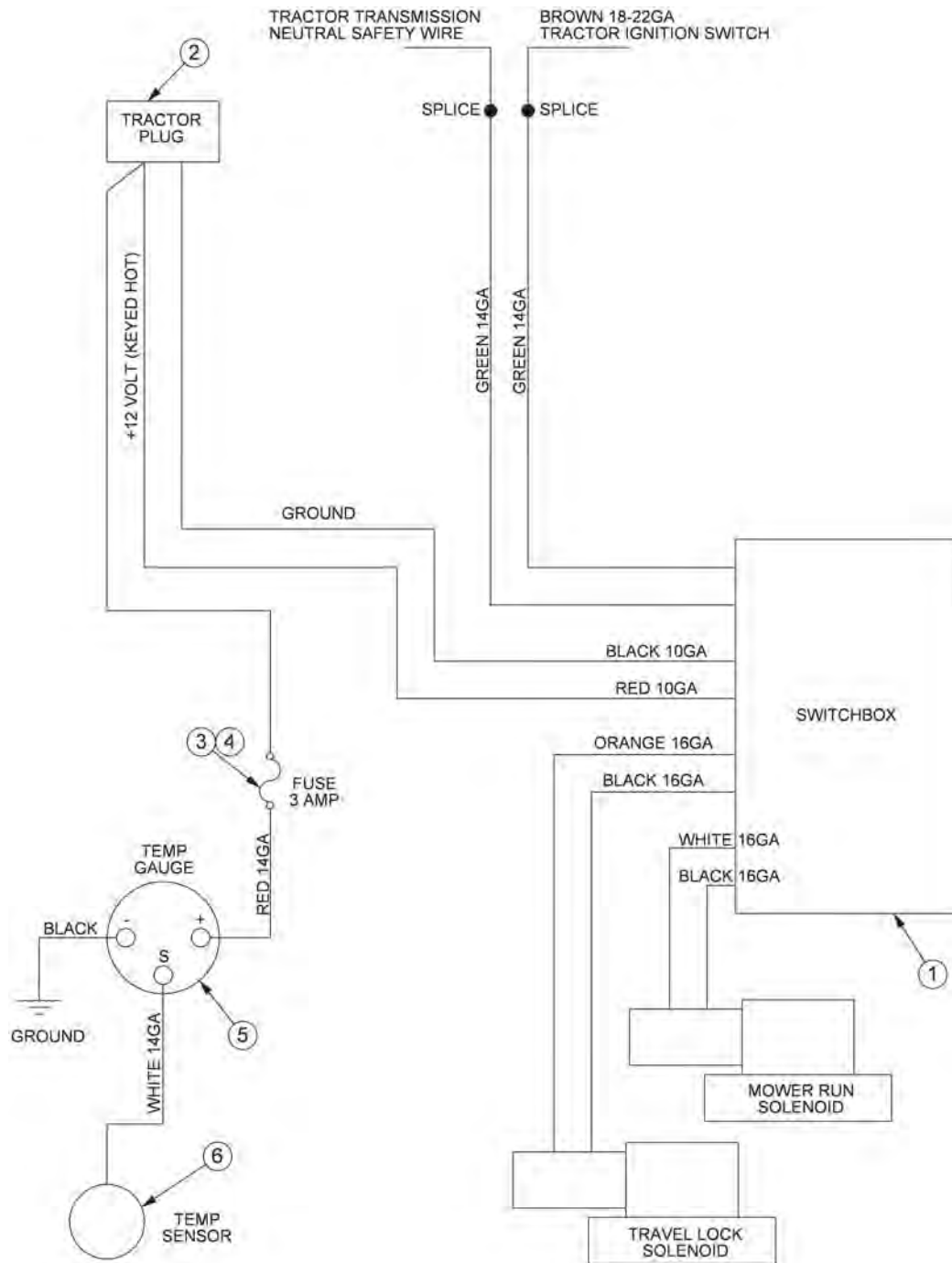

ITEM	PART NO.	QTY.	DESCRIPTION
1	*	REF	SWITCH BOX
2	RE37651	1	PLUG,AUX PWR
3	24204	OPT.	FUSE HOLDER,IN-LINE
4	6T3965	OPT.	FUSE,3AMP
5	6T3934	OPT.	TEMPERATURE GAUGE
6	6T3931	OPT.	TEMPERATURE SENSOR

# WHEEL SPACER

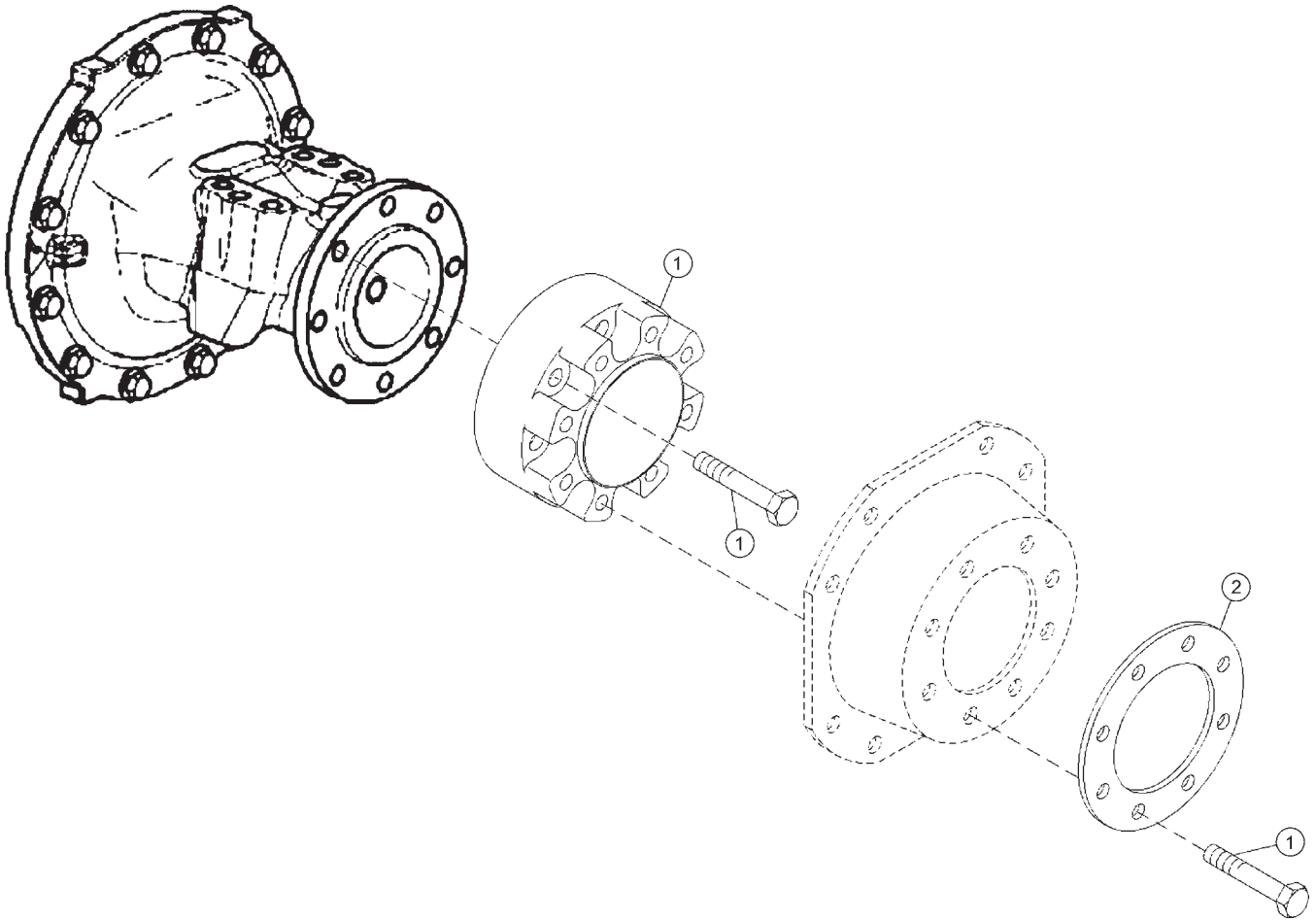

ITEM	PART NO.	QTY.	DESCRIPTION
1	06770025	1	KIT,SPCR,WHL,JD
2	06400919	2	RING,SPACER,WHEEL,JD



# WHEEL WEIGHT ASSEMBLY

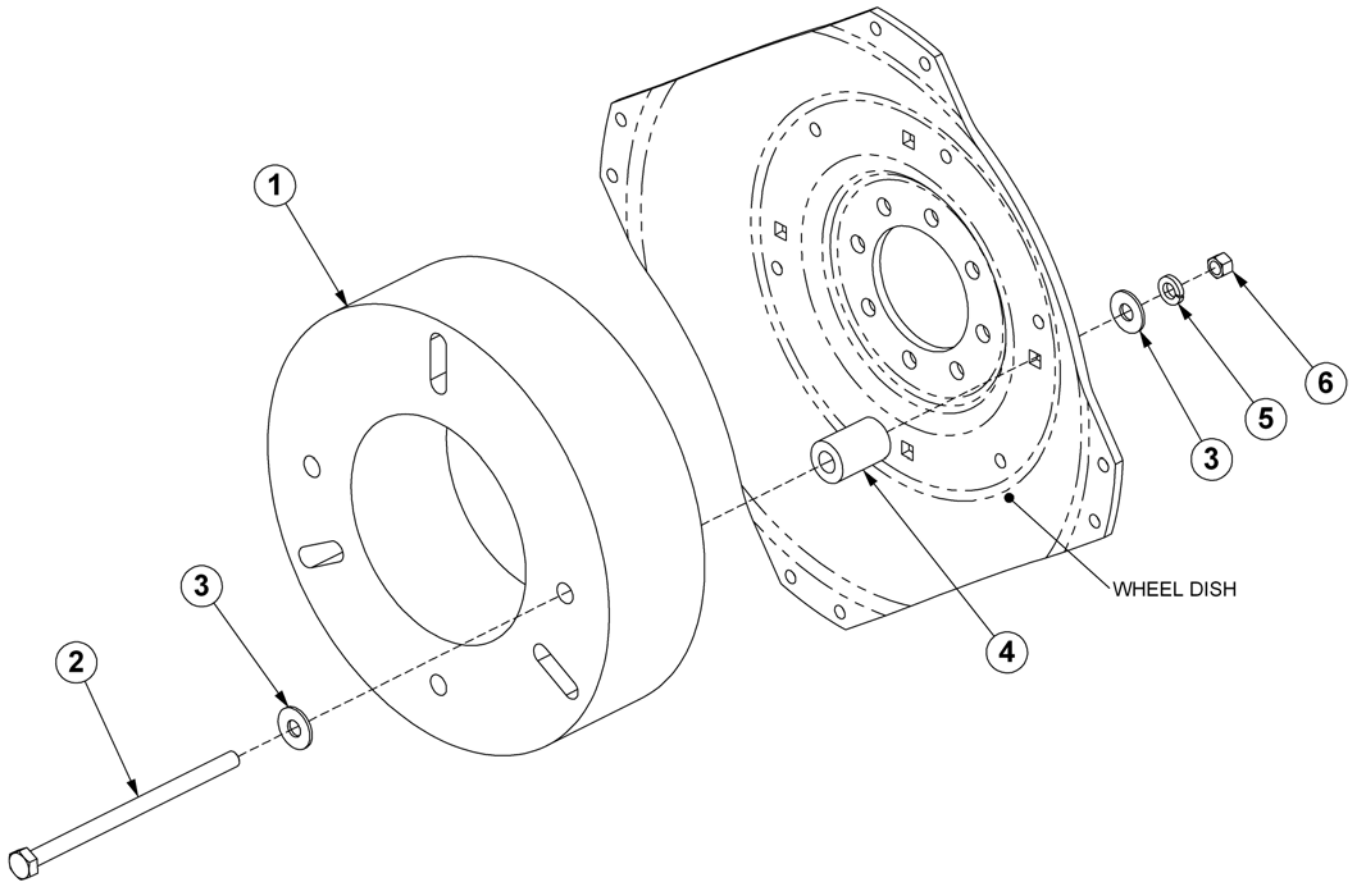

ITEM	PART NO.	QTY.	DESCRIPTION
1	30687	1	500# WHEEL WEIGHT
2	21956	4	CAPSCREW - 3/4 X 13
3	33626	8	FLATWASHER - 3/4
4	TB3278	4	SPACER
5	21993	4	LOCKWASHER - 3/4
6	21825	4	HEX NUT - 3/4

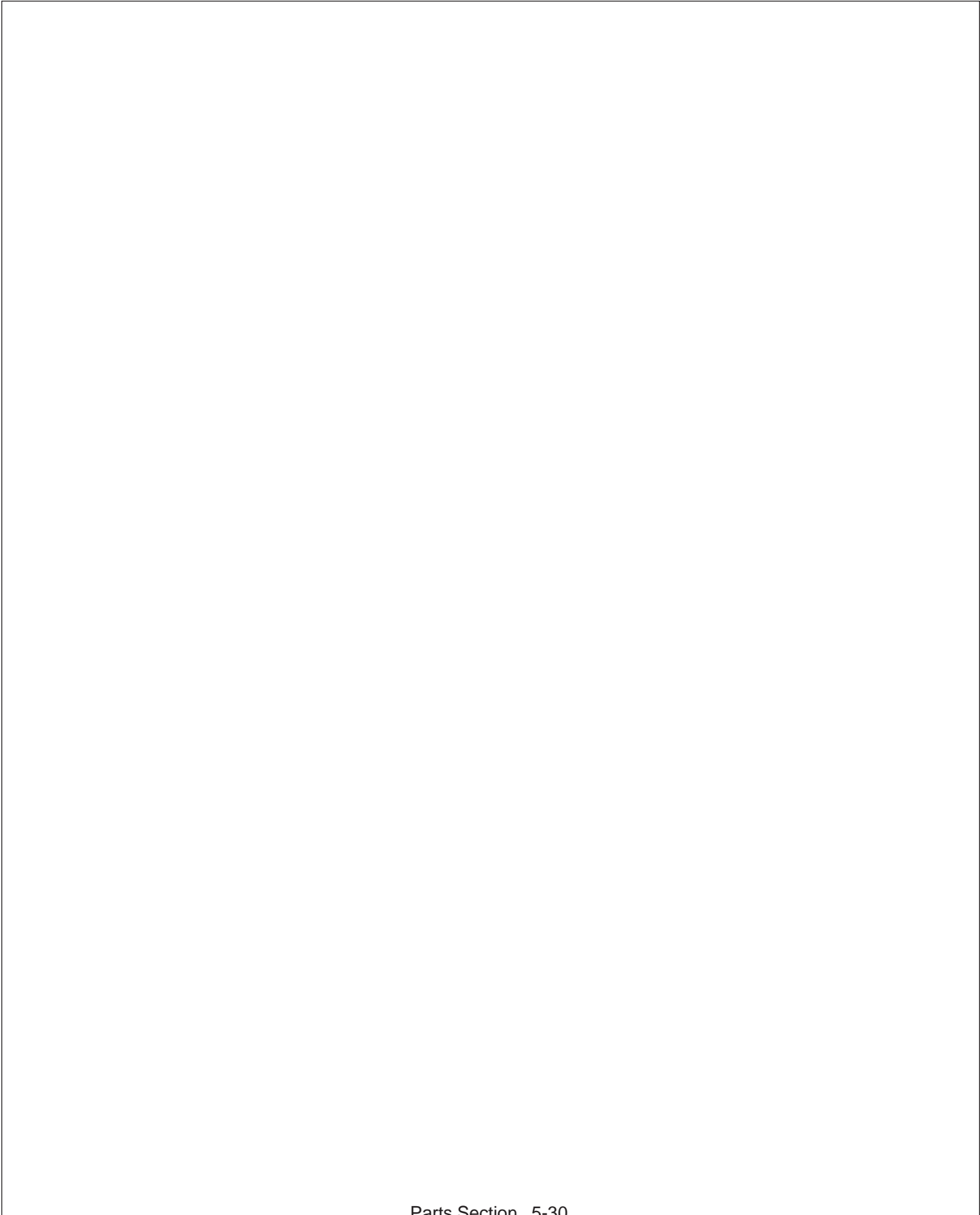

# **CHEETAH BOOM MOWER**

## **COMMON PARTS SECTION**

# PARTS ORDERING GUIDE

The following instructions are offered to help eliminate needless delay and error in processing purchase orders for the equipment in this manual.

1. The Parts Section is prepared in logical sequence and grouping of parts that belong to the basic machine featured in this manual. Part Numbers and Descriptions are given to help locate the parts and quantities required.

2. The Purchase Order must indicate the **Name and Address** of the person or organization ordering the parts, **who should be charged**, and if possible, the **serial number of the machine** for which the parts are being ordered.

3. The purchase order must clearly list the **quantity of each part**, the complete and correct **part number**, and the basic **name of the part**.

4. The manufacturer reserves the right to substitute parts where applicable.

5. Some parts may be unlisted items which are special production items not normally stocked and are subject to special handling. Request a quotation for such parts before sending a purchase order.

6. The manufacturer reserves the right to change prices without prior notice.

NOTE: When ordering replacement decals, refer to the part numbers and descriptions listed in the safety section in the front of this manual.



1000

For maximum safety and to guarantee optimum product reliability, always use genuine **Tiger** replacement parts. The use of inferior replacement parts may cause premature or catastrophic failure which could result in serious injury or death.

Direct any questions regarding parts to:

**Tiger Corporation**  
3301 N. Louise Ave.  
Sioux Falls, SD 57107  
**1-800-843-6849**  
**1-605-336-7900**

# PARTS SECTION TABLE OF CONTENTS

<b>SECTION</b>	<b>PAGE</b>
<b>TRACTOR SPECIFIC PARTS:</b>	
CHEETAH QUICK COUPLERS	6-4
CHEETAH BOOM ARM ASSY	6-6
CHEETAH ROTARY MOWER DECK	6-8
CHEETAH ROTARY PIVOT ASSY.	6-10
DAN FOSS VALVE BREAKDOWN	6-12
HUSCO VALVE BREAKDOWN	6-14
CHEETAH ROTARY MOTOR	6-20
ROTARY SPINDLE ASSY.	6-22
CHEETAH FLAIL HEAD ASSY.	6-24
CHEETAH FLAIL - CUTTER SHAFT ASSY.	6-26
CHEETAH FLAIL MOTOR	6-28
CHEETAH CYLINDER BREAKDOWNS	6-30
RESERVOIR TANK FILTER ASSEMBLY	6-34
BRAKE VALVE ASSEMBLY W/METRI PAK	6-35
BOOM TRAVEL LOCK	6-36
SOLENOID BRAKE VALVE HYDRO SCHEMATIC	6-37
JOYSTICK SWITCH BOX SERVICE PARTS	6-38
JOYSTICK SCHEMATIC	6-39
HUSCO CONTROLS SWITCHBOX	6-40
OPTIONAL PUMP GUARD KITS	6-42
OPTIONAL GRILL GUARD	6-43
TROUBLESHOOTING	6-44
HYDRAULIC - TROUBLESHOOTING GUIDE	6-46
ELECTRICAL - TROUBLESHOOTING GUIDE	6-47

# CHEETAH QUICK COUPLERS - MAIN BOOM

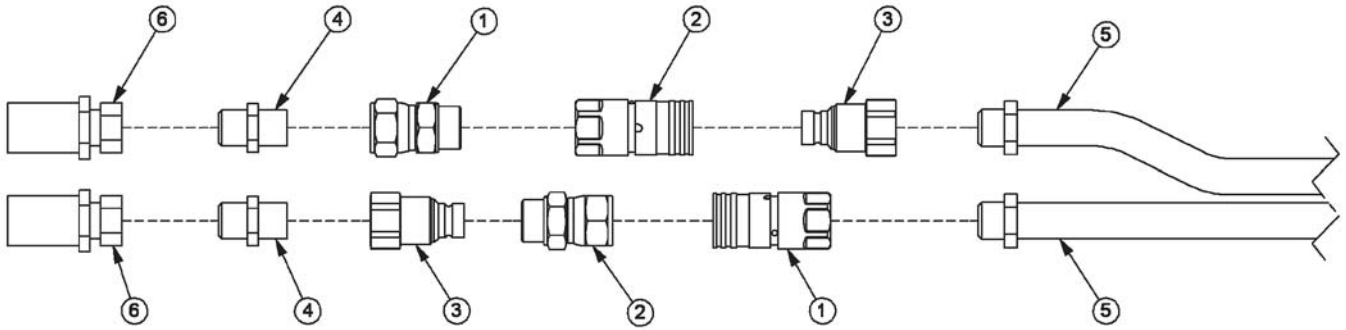



## CHEETAH QUICK COUPLERS - MAIN BOOM

ITEM	PART NO.	QTY.	DESCRIPTION
1	34392	2	ADAPTER,1ORB X 1FJX
2	06503027	2	QUICK COUPLER,1"SAE,FEMALE
3	06503028	2	QUICK COUPLER,1"SAE,MALE
4	33555	2	ADAPTER,1MORB X 1MJIC
5	*	REF.	<b>PREFORMED TUBES - REFER TO BOOM ARM PARTS</b>
6	*	REF.	<b>#16 HOSE - REFER TO HYDRAULIC PARTS</b>

# CHEETAH BOOM ARM ASSEMBLY

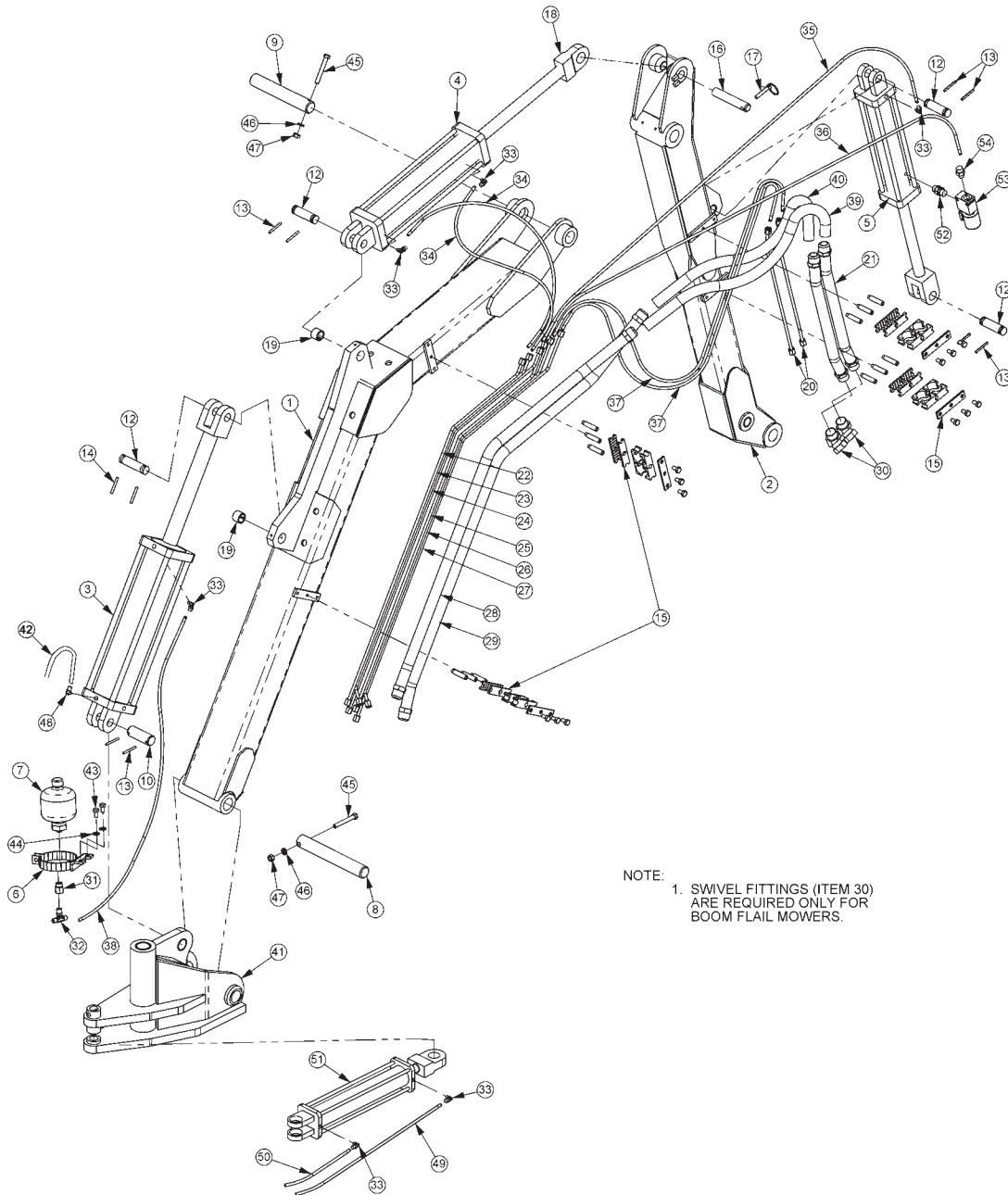

NOTE:  
1. SWIVEL FITTINGS (ITEM 30)  
ARE REQUIRED ONLY FOR  
BOOM FLAIL MOWERS.

# CHEETAH BOOM ARM ASSEMBLY

ITEM	PART NO.	QTY.	DESCRIPTION
1	31153A	1	MAIN BOOM ARM
2	31154A	1	SECONDARY BOOM ARM
3	33702	1	CYLINDER
4	33703	1	CYLINDER
5	33731	1	CYLINDER
6	23888	1	ACCUMULATOR BRACKET
7	33470	1	ACCUMULATOR
8	33442	1	PIN
9	33443	1	PIN
10	06420053	1	PIN
12	TB1033	4	PIN, CLEVIS
13	06537021	8	ROLL PIN
14	6T3014	3	ROLL PIN
15	33440	4	TUBE CLAMP KIT
16	33503	1	PIN
17	TF1143	1	LYNCH PIN
18	TB3033	1	CLEVIS
19	TB3010	3	BUSHING
20	33174	2	PREFORMED TUBE
21	33181	2	PREFORMED TUBE
22	33175	1	PREFORMED TUBE
23	33176	1	PREFORMED TUBE
24	33178	1	PREFORMED TUBE
25	33177	1	PREFORMED TUBE
26	33179	1	PREFORMED TUBE
27	33180	1	PREFORMED TUBE
28	33182	1	PREFORMED TUBE
29	33183	1	PREFORMED TUBE
30	24724	2	SWIVEL
31	28917	1	ADAPTER
32	32821	1	TEE
33	32810	7	ELBOW
34	33395	2	HOSE
35	33449	1	HOSE
36	33450	1	HOSE
37	33504	2	HOSE
38	*	REF	REFER TO PARTS SECTION
39	33451	1	HOSE
40	33452	1	HOSE
41	*	REF	REFER TO MAIN FRAME PARTS
42	*	REF	REFER TO PARTS SECTION
43	21629	2	CAPSCREW - 3/8 X 3/4
44	21988	2	LOCKWASHER - 3/8
45	21688	2	CAPSCREW - 7/16 X 3 1/4
46	21989	2	LOCKWASHER - 7/16
47	21675	2	HEX NUT - 7/16
48	33399	1	ELBOW
49	*	REF	REFER TO PARTS SECTION
50	*	REF	REFER TO PARTS SECTION
51	34275	1	SWIVEL CYL.
52	31329	1	ADAPTER 1/2" ORB X 1/2" ADJ
53	06510050	1	TRAVEL LOCK VALVE
54	33271	1	ADAPTER 1/2" OR X 3/8" MJ
55	33513	1	DECAL KIT (NOT SHOWN)

# CHEETAH ROTARY MOWER DECK

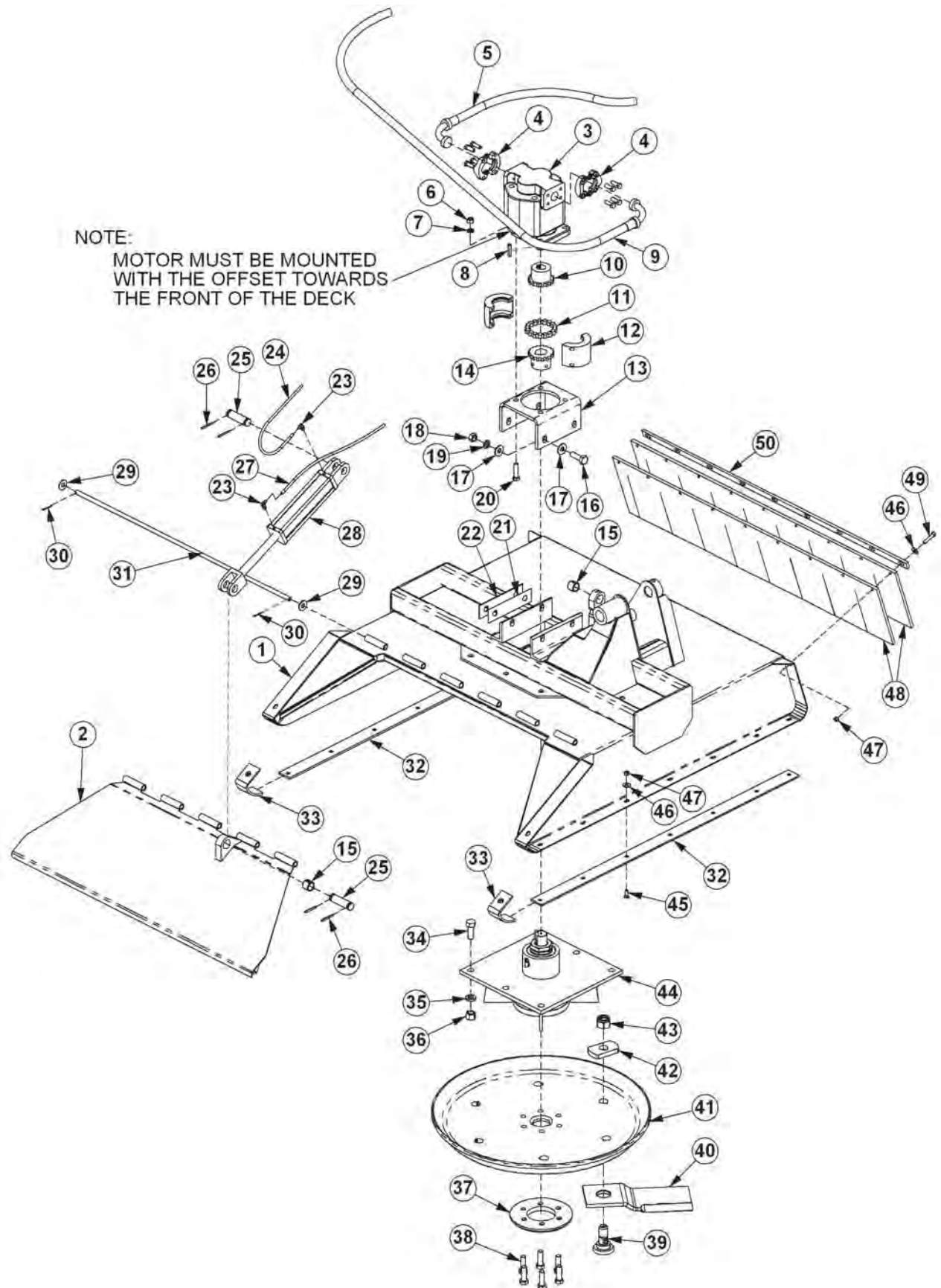

# CHEETAH ROTARY MOWER DECK

ITEM	PART NO.	QTY.	DESCRIPTION
	<b>33425</b>	<b>AVAIL.</b>	<b>CHEETAH ROTARY HEAD, COMPLETE ASSY.</b>
1	32974	1	CHEETAH ROTARY DECK
2	32977	1	SHEILD
3	06504012	1	MOTOR
4	<b>TF4852</b>	<b>2</b>	<b>FLANGE KIT</b>
5	33433	1	HOSE 1" x 79"
6	21725	4	HEX NUT, 1/2, NC
7	21990	4	LOCKWASHER, 1/2
8	TF1124	1	KEY
9	24490	1	HOSE 1" x 57"
10	21223	1	SPROCKET
11	6T1029	1	CHAIN COUPLING
12	6T1033	1	COUPLING COVER
13	6T1001	1	MOTOR MOUNTING BRACKET
14	*	REF	REFER TO SPINDLE PARTS
15	34878	3	SPACER
16	21783	4	CAPSCREW, 5/8 X 2, NC
17	25270	8	FLATWASHER, 5/8, GR8
18	21775	4	HEX NUT, 5/8, NC
19	21992	4	LOCKWASHER, 5/8
20	21733	4	CAPSCREW, 1/2 X 2, NC
21	6T0822A	2	SHIM
22	6T0822	3	SHIM
23	32810	2	ELBOW
24	33431	1	HOSE 1/4" x 72"
25	6T3003D	2	CLEVIS PIN
26	TB1023	4	ROLL PIN
27	33430	1	HOSE 1/4" x 82"
28	6T7022	1	CYLINDER
29	22018	2	FLATWASHER, 1/2, WIDE
30	22516	2	COTTER PIN
31	33417	1	HINGE PIN
32	32981	2	SKID SHOE
33	32982	2	SKID SHOE
34	6T2277	6	CAPSCREW, 3/4 X 2, NF, GR8
35	21993	6	LOCKWASHER, 3/4
36	6T2413	6	HEX NUT, 3/4, NF, GR8
37	TB2029-5	1	BOLT PROTECTOR
38	6T2290	6	CAPSCREW, 5/8 X 2, NF, GR8
39	34497	3	KNIFE MOUNTING BOLT
40	34686	3	KNIFE
41	06700001	1	KIT, TRB50 DISK, W/BOLT KIT
42	34878	3	SPACER
43	6T1023R	3	KNIFE MOUNTING NUT
44	*	REF	REFER TO SPINDLE PARTS
45	6T2270	20	PLOW BOLT, 3/8 X 1, NC
46	22016	29	FLATWASHER, 3/8
47	21625	29	HEX NUT, 3/8, NC
48	32975	2	DEFLECTOR FLAP
49	21633	9	CAPSCREW, 3/8 X 1-3/4, NC
50	32988	1	FLAP, RETAINING BAR
*	<b>33890</b>	<b>AVAIL</b>	<b>KIT BLADE, BOLT, NUT (INCLUDES ITEMS 39, 40 &amp; 43)</b>

# CHEETAH ROTARY PIVOT ASY.

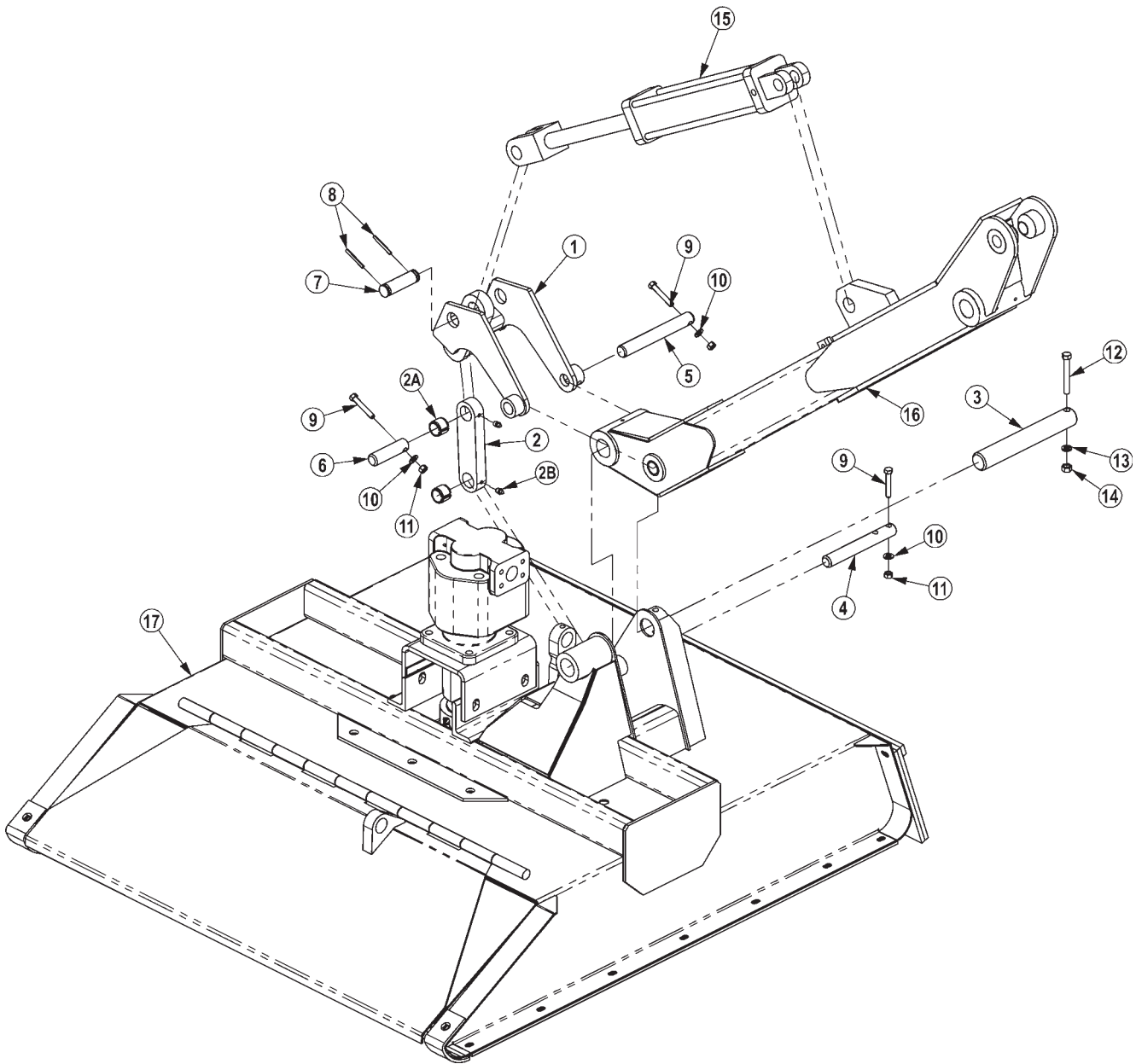

## CHEETAH ROTARY PIVOT ASY.

ITEM	PART NO.	QTY.	DESCRIPTION
1	31267	1	PIVOT WELDMENT
2	33523	1	PIVOT LINK
2a	TB3010	2	BUSHINGS
2b	6T3207	2	GREASE ZERKS
*3	33426	1	PIN (ROTARY)
*3a	33867	1	PIN (FLAIL)
4	33427	1	PIN
5	33428	1	PIN
6	33429	1	PIN
7	6T3003D	1	CLEVIS PIN
8	TB1023	2	ROLL PIN
9	21635	3	CAPSCREW - 3/8 X 2 1/4
10	21988	3	LOCKWASHER - 3/8
11	21625	3	HEX NUT - 3/8
12	21688	1	CAPSCREW - 7/16 X 3 1/4
13	21989	1	LOCKWASHER - 7/16
14	21675	1	HEX NUT - 7/16
15	*	REF	REFER TO BOOM ARM PARTS
16	*	REF	REFER TO BOOM ARM PARTS
17	*	REF	REFER TO ROTARY HEAD PARTS

NOTE: ITEM \*3 IS USED ON THE ROTARY HEAD ONLY,  
ITEM \*3A IS USED ON THE FLAIL HEAD ONLY.



# DAN FOSS VALVE (06502095)

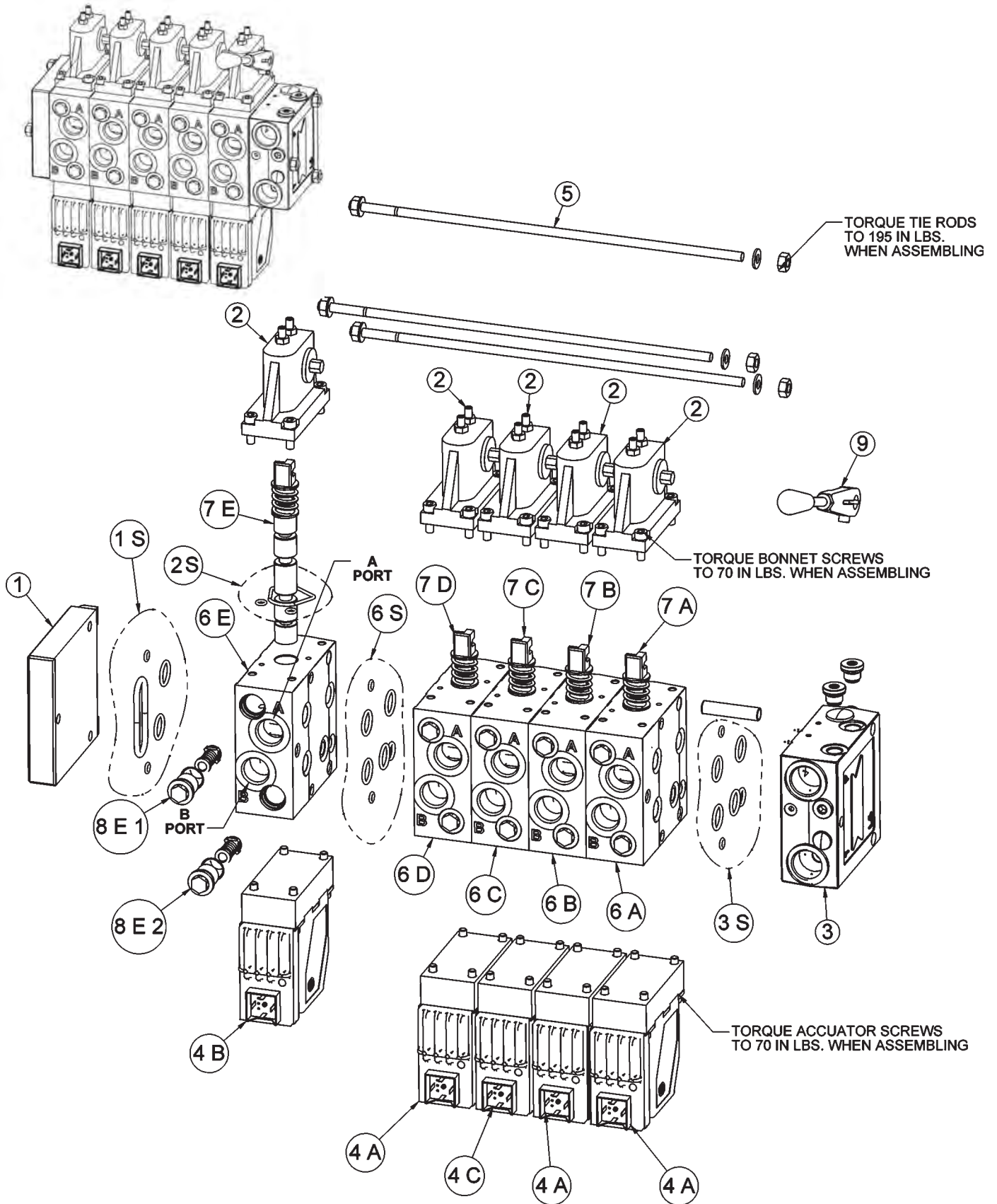

# DAN FOSS VALVE (06502095)

ITEM	PART NO.	QTY.	DESCRIPTION
	<b>06502095</b>		<b>VLV,5SP,32PVG</b>
1	06502074	1	END PLATE
1S	06505013	1	END PLATE SEAL KIT
2	*	5	BONNET
2S	06505042	1	BONNET SEAL KIT
2A	33459	1	MAIN BOOM BONNET
2B	42197	1	SECONDARY BOOM BONNET
2B	42197	1	DECK ROLL BONNET
2B	42197	1	BOOM SWIVEL BONNET
2B	42197	1	DECK SHIELD BONNET
3	34308	1	INLET SECTION
3S	06505013	1	INLET SECTION SEAL KIT
4	*	5	ELECTRONIC ACCUATOR
4S	34030	1	ELECTRONIC ACCUATOR SEAL KIT
4A	06502101	1	MAIN BOOM ELECTRONIC ACCUATOR
4A	06502101	1	SECONDARY BOOM ELECTRONIC ACCUATOR
4A	06502101	1	DECK ROLL ELECTRONIC ACCUATOR
4C	06502100	1	BOOM SWIVEL ELECTRONIC ACCUATOR
4B	06502101	1	DECK SHIELD ELECTRONIC ACCUATOR
5	06502099	1	TIE-BOLT KIT
6	*	5	SECTION
6S	06505013	1	SECTION SEAL KIT
6A	42698	1	MAIN BOOM SECTION
6B	42698	1	SEC BOOM SECTION
6C	06502076	1	DECK ROLL SECTION
6D	42698	1	BOOM SWIVEL SECTION
6E	06502077	1	SHIELD SECTION
7	*	5	SPOOL
7A	4229806	1	MAIN BOOM SPOOL
7B	4229806	1	SEC BOOM SPOOL
7C	42297	1	DECK ROLL BOOM SPOOL
7D	06502073	1	BOOM SWIVEL SPOOL
7E	42201	1	DECK SHIELD SPOOL
8	*	10	ANTI CAV/SHOCK RELIEF
8A1	42296	1	MAIN BOOM A PORT RELIEF
8A2	06502069	1	MAIN BOOM B PORT RELIEF
8B1	42295	1	SEC BOOM A PORT RELIEF
8B2	42295	1	SEC BOOM B PORT RELIEF
8C1	42295	1	DECK ROLL A PORT RELIEF
8C2	42295	1	DECK ROLL B PORT RELIEF
8D1	42295	1	BOOM SWIVEL A PORT RELIEF
8D2	42295	1	BOOM SWIVEL B PORT RELIEF
8E1	06502069	1	DECK SHIELD A PORT RELIEF
8E2	06502069	1	DECK SHIELD B PORT RELIEF
9	33459	1	HANDLE

# 5SP HUSCO - POWER BEYOND (33500)

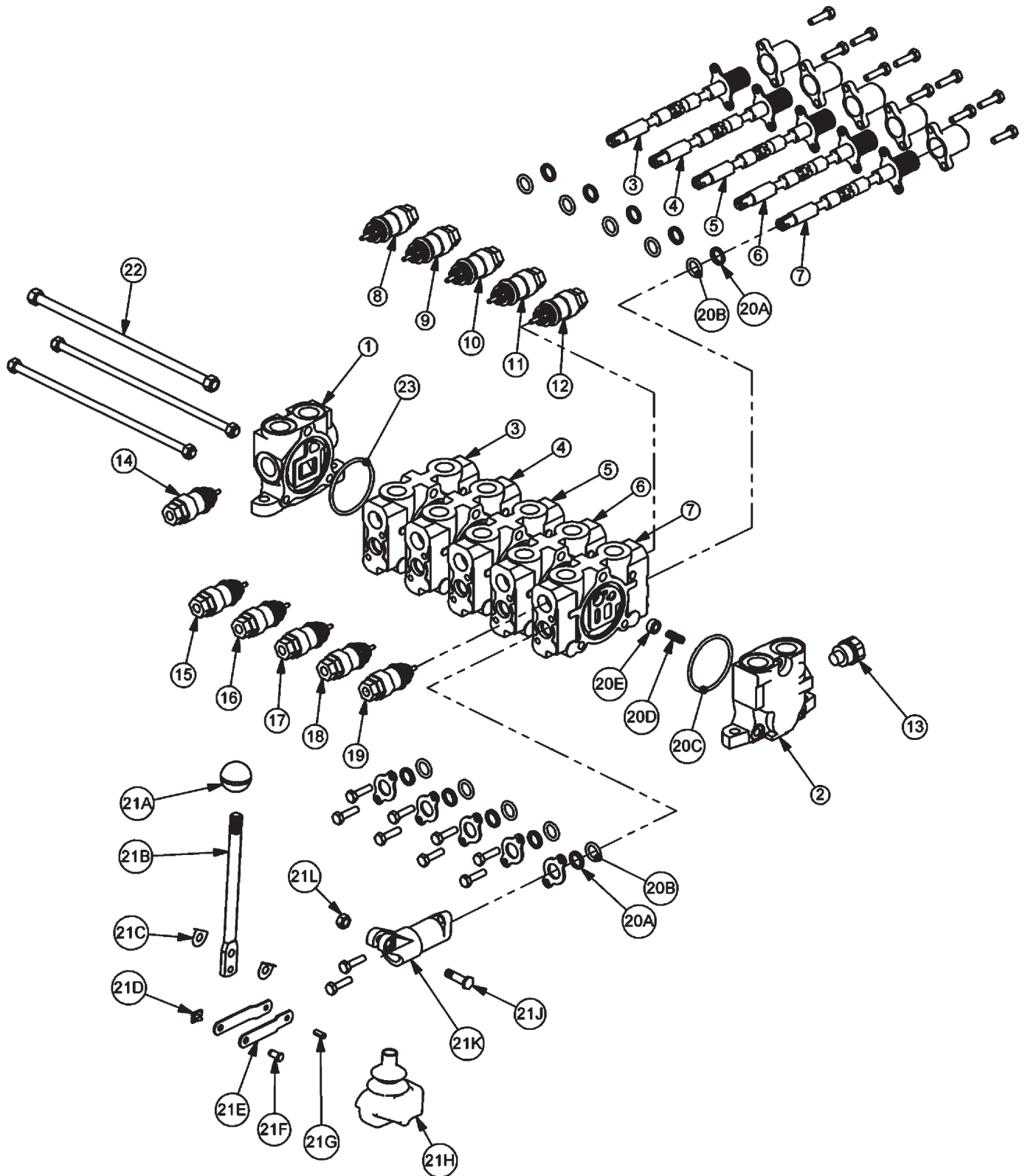

## 5SP HUSCO - POWER BEYOND (33500)

ITEM	PART NO.	QTY	DESCRIPTION
1	TB1017S	1	INLET END COVER
2	TB1702	1	END COVER, POWER BEYOND
3	TB1017P	1	VALVE SECTION (SINGLE ACTING, SPRING DETENT)
4	TB1017N	1	VALVE SECTION (DOUBLE ACTING, CENTER SPRING)
5	TB1017N	1	VALVE SECTION (DOUBLE ACTING, CENTER SPRING)
6	TB1017Q	1	VALVE SECTION (DOUBLE ACTING, SPRING METERED)
7	TB1017N	1	VALVE SECTION (DOUBLE ACTING, CENTER SPRING)
8	N/A	-	N/A
9	TB1017K	1	RELIEF VALVE, 2150 PSI
10	TB1017J	1	RELIEF VALVE, 1800 PSI
11	TB1017H	1	RELIEF VALVE, 1750 PSI
12	22580	1	RELIEF VALVE, 500 PSI
13	TB1017M	1	SHUT-OFF PLUG
14	06502037	1	RELIEF VALVE, 2600 PSI
15	06502003	1	RELIEF VALVE, 2500 PSI
16	TB1017F	1	RELIEF VALVE, 1500 PSI
17	TB1017F	1	RELIEF VALVE, 1500 PSI
18	TB1017H	1	RELIEF VALVE, 1750 PSI
19	22580	1	RELIEF VALVE, 500 PSI
20	TB1017A	5	VALVE SEAL KIT (FOR ONE SECTION)
	20A	2	WIPER
	20B	2	O-RING SMALL
	20C	1	O-RING LARGE
	20D	1	SPRING
	20E	1	PUCKET
21	TB1017L	5	LEVER KIT (FOR ONE SECTION)
	21A	1	LEVER KNOB
	21B	1	LEVER
	21C	2	LEVER WASHER
	21D	1	LEVER CLIP
	21E	2	LINKAGE
	21F	1	LEVER PIN
	21G	1	ROLL PIN
	21H	1	LEVER BOOT
	21J	1	LEVER BOLT
	21K	1	LEVER DUST COVER
	21L	1	LEVER NUT
22	TB1017V	1	TIE ROD KIT
23	24214	1	O-RING, LARGE

# 5SP HUSCO - OPEN CENTER (34287)

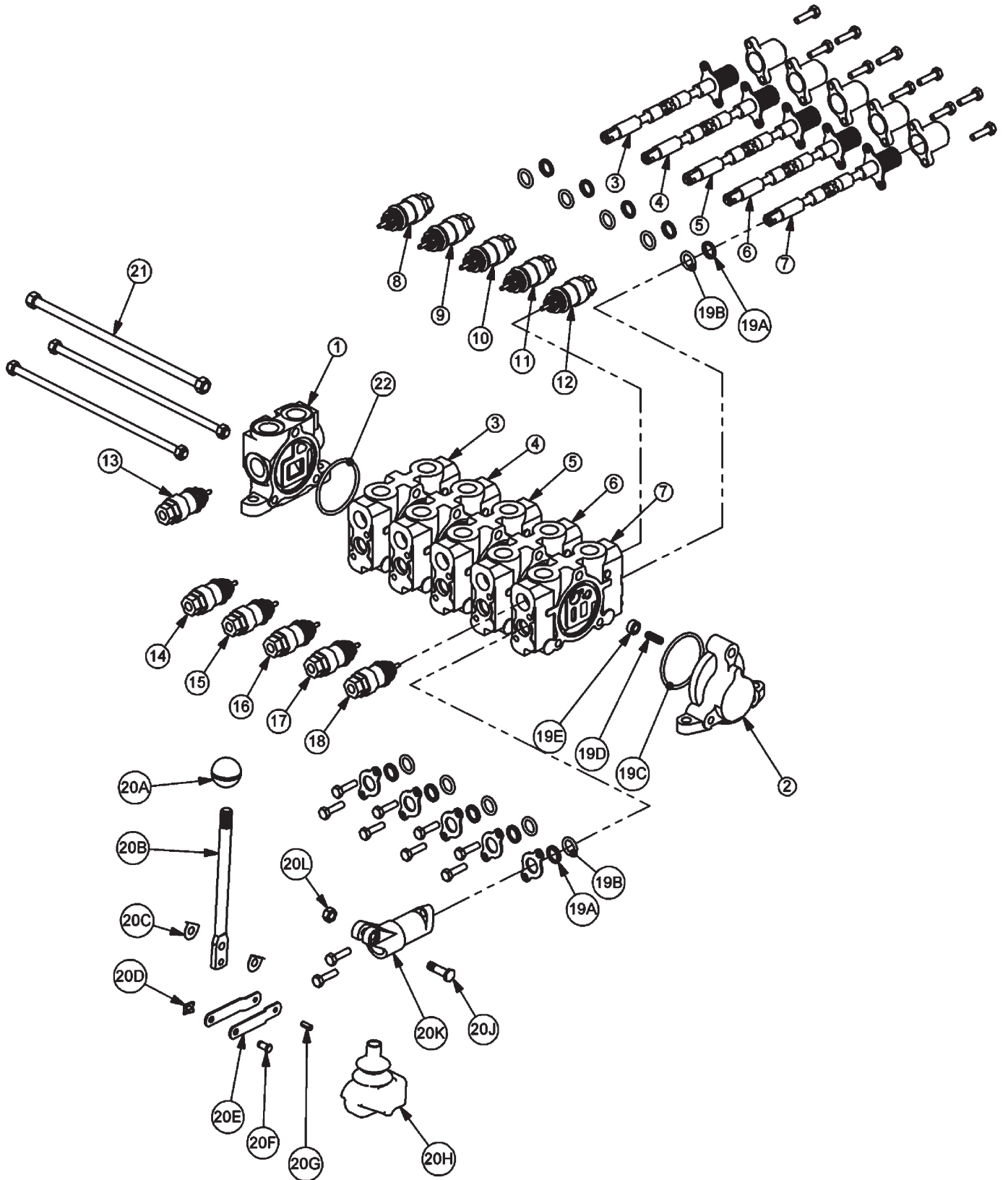

## 5SP HUSCO - OPEN CENTER (34287)

ITEM	PART NO.	QTY	DESCRIPTION
1	TB1017S	1	INLET END COVER
2	TB1701	1	END COVER, OPEN CENTER
3	TB1017P	1	VALVE SECTION (SINGLE ACTION, SPRING DETENT)
4	TB1017N	1	VALVE SECTION (DOUBLE ACTING, CENTER SPRING)
5	TB1017N	1	VALVE SECTION (DOUBLE ACTING, CENTER SPRING)
6	TB1017Q	1	VALVE SECTION (DOUBLE ACTING, SPRING METERED)
7	TB1017N	1	VALVE SECTION (DOUBLE ACTING, CENTER SPRING)
8	N/A	-	N/A
9	TB1017K	1	RELIEF VALVE, 2150 PSI
10	TB1017J	1	RELIEF VALVE, 1800 PSI
11	TB1017H	1	RELIEF VALVE, 1750 PSI
12	22580	1	RELIEF VALVE, 500 PSI
13	06502037	1	RELIEF VALVE, 2600 PSI
14	TB1017G	1	RELIEF VALVE, 2250 PSI
15	TB1017F	1	RELIEF VALVE, 1500 PSI
16	TB1017F	1	RELIEF VALVE, 1500 PSI
17	TB1017H	1	RELIEF VALVE, 1750 PSI
18	22580	1	RELIEF VALVE, 500PSI
19	TB1017A	5	VALVE SEAL KIT (FOR ONE SECTION)
19A		2	WIPER
19B		2	O-RING SMALL
19C		1	O-RING LARGE
19D		1	SPRING
19E		1	PUCKET
20	TB1017L	5	LEVER KIT (FOR ONE SECTION)
20A		1	LEVER KNOB
20B		1	LEVER
20C		2	LEVER WASHER
20D		1	LEVER CLIP
20E		2	LINKAGE
20F		1	LEVER PIN
20G		1	ROLL PIN
20H		1	LEVER BOOT
20J		1	LEVER BOLT
20K		1	LEVER DUST COVER
20L		1	LEVER NUT
21	TB1017V	1	TIE ROD KIT
22	24214	1	O-RING, LARGE

# 4SP HUSCO LIFT VALVE - FLAIL - OPEN CENTER (27671)

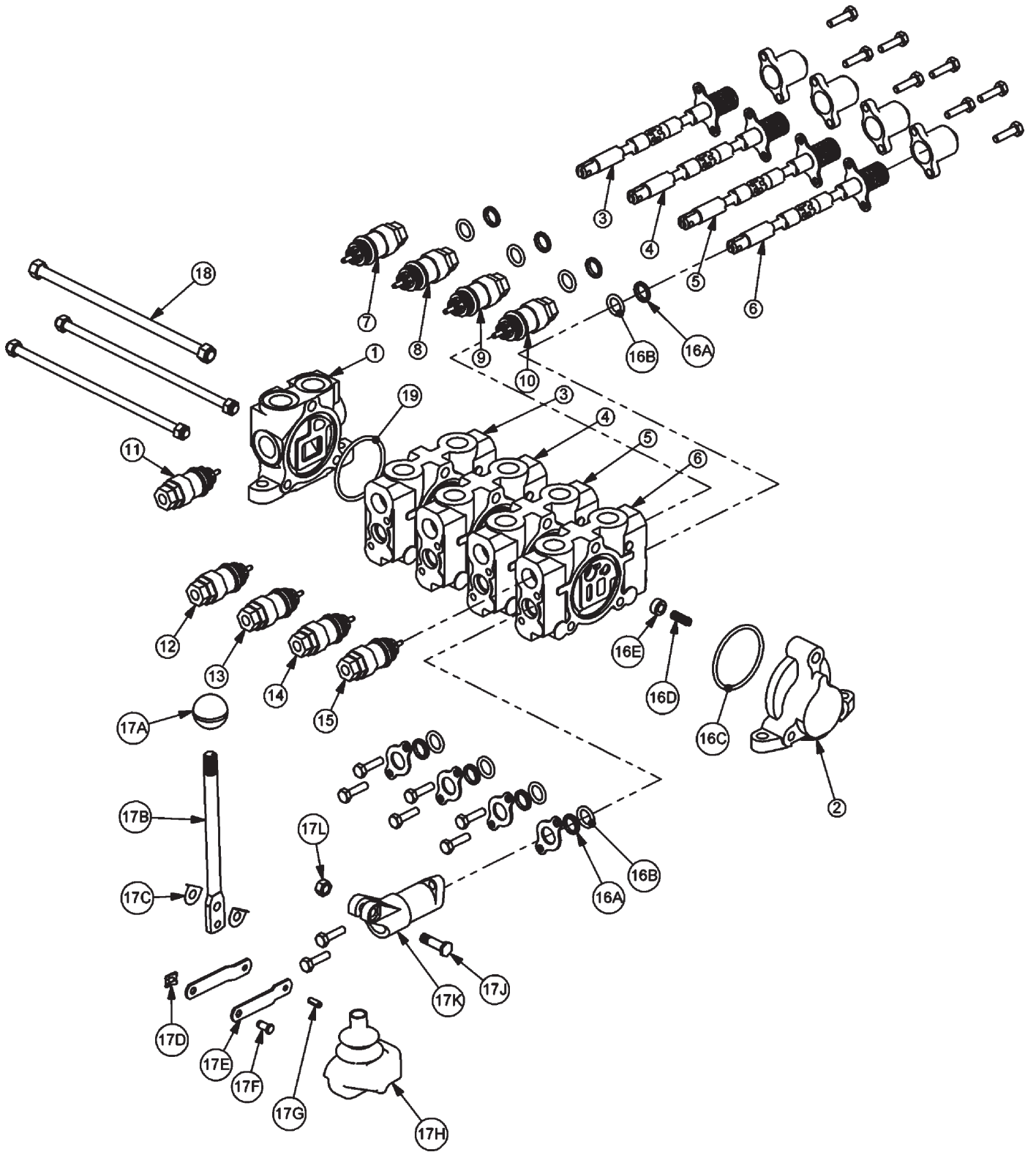



## 4SP HUSCO LIFT VALVE - OPEN CENTER (27671)

ITEM	PART NO.	QTY	DESCRIPTION
1	TB1017S	1	INLET END COVER
2	TB1701	1	END COVER, OPEN CENTER
3	TB1017P	1	VALVE SECTION (SINGLE ACTING, SPRING DETENT)
4	TB1017N	1	VALVE SECTION (DOUBLE ACTING, CENTER SPRING)
5	TF3009	1	VALVE SECTION (DOUBLE ACTING, DETENT - FLOAT)
6	TB1017Q	1	VALVE SECTION (DOUBLE ACTING, SPRING METERED)
7	N/A	-	N/A
8	TB1017K	1	RELIEF VALVE, 2150 PSI
9	TB1017J	1	RELIEF VALVE, 1800 PSI
10	TB1017H	1	RELIEF VALVE, 1750 PSI
11	06502037	1	RELIEF VALVE, 2600 PSI
12	06502003	1	RELIEF VALVE, 2500 PSI
13	TB1017F	1	RELIEF VALVE, 1500 PSI
14	TB1017F	1	RELIEF VALVE, 1500 PSI
15	TB1017H	1	RELIEF VALVE, 1750 PSI
16	TB1017A	4	VALVE SEAL KIT (FOR ONE SECTION)
16A		2	WIPER
16B		2	O-RING SMALL
16C		1	O-RING LARGE
16D		1	SPRING
16E		1	PUCKET
17	TB1017L	4	LEVER KIT (FOR ONE SECTION)
17A		1	LEVER KNOB
17B		1	LEVER
17C		2	LEVER WASHER
17D		1	LEVER CLIP
17E		2	LINKAGE
17F		1	LEVER PIN
17G		1	ROLL PIN
17H		1	LEVER BOOT
17J		1	LEVER BOLT
17K		1	LEVER DUST COVER
17L		1	LEVER NUT
18	TB1017U	1	TIE ROD KIT
19	24214	1	O-RING, LARGE

# CHEETAH ROTARY MOTOR

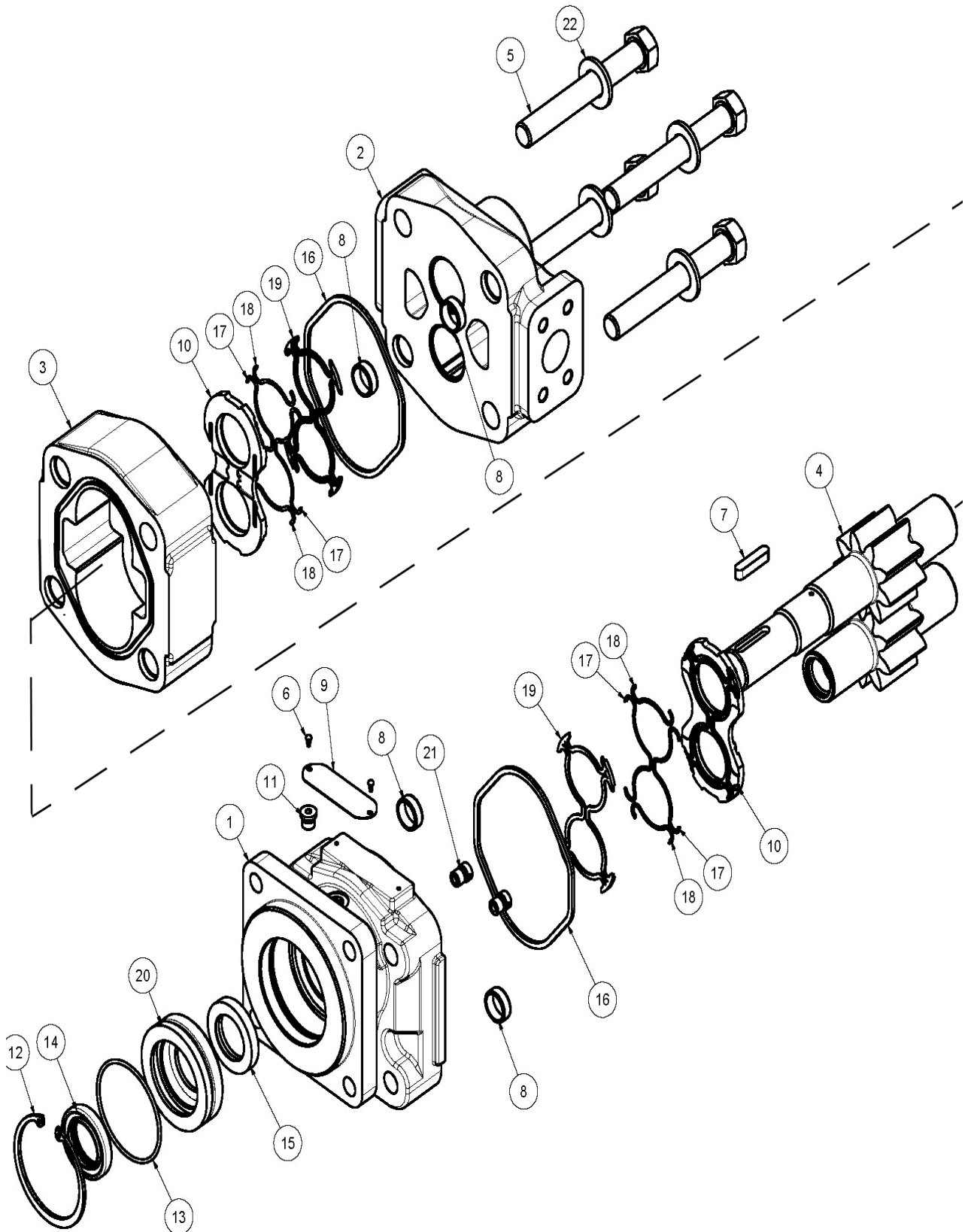

# CHEETAH ROTARY MOTOR

ITEM	PART NO.	QTY.	DESCRIPTION
*	<b>06504012</b>	<b>AVAIL</b>	<b>MOTOR ASSEMBLY - CHEETAH ROTARY</b>
1	22790	1	SHAFT END COVER
2	06504088	1	PORT END COVER
3	02404289	1	GEAR HOUSING
4	06504090	1	MATCHED GEAR SET
5	06504091	4	CAP SCREW
6	06504078	2	SET SCREW
7	06504092	1	KEY
8	06504093	4	DOWEL PIN
9	06504094	1	NAMEPLATE
10	06504095	2	THRUST PLATE
11	02961940	1	HEX PLUG
12	02962200	1	SNAP RING
13	06504096	1	O-RING
14	6T5101	1	LIP SEAL
15	06504097	1	LIP SEAL
16	22797	2	SEAL, SQ-R
17	06504098	4	SEAL, SIDE CHAIN
18	06504099	4	SEAL, END CHAIN
19	06504100	2	SEAL, BK-UP
20	06504101	1	RTNR, SEAL
21	6T5809	2	CHECK ASSY
22	06504102	4	WASHER

# ROTARY SPINDLE ASSEMBLY

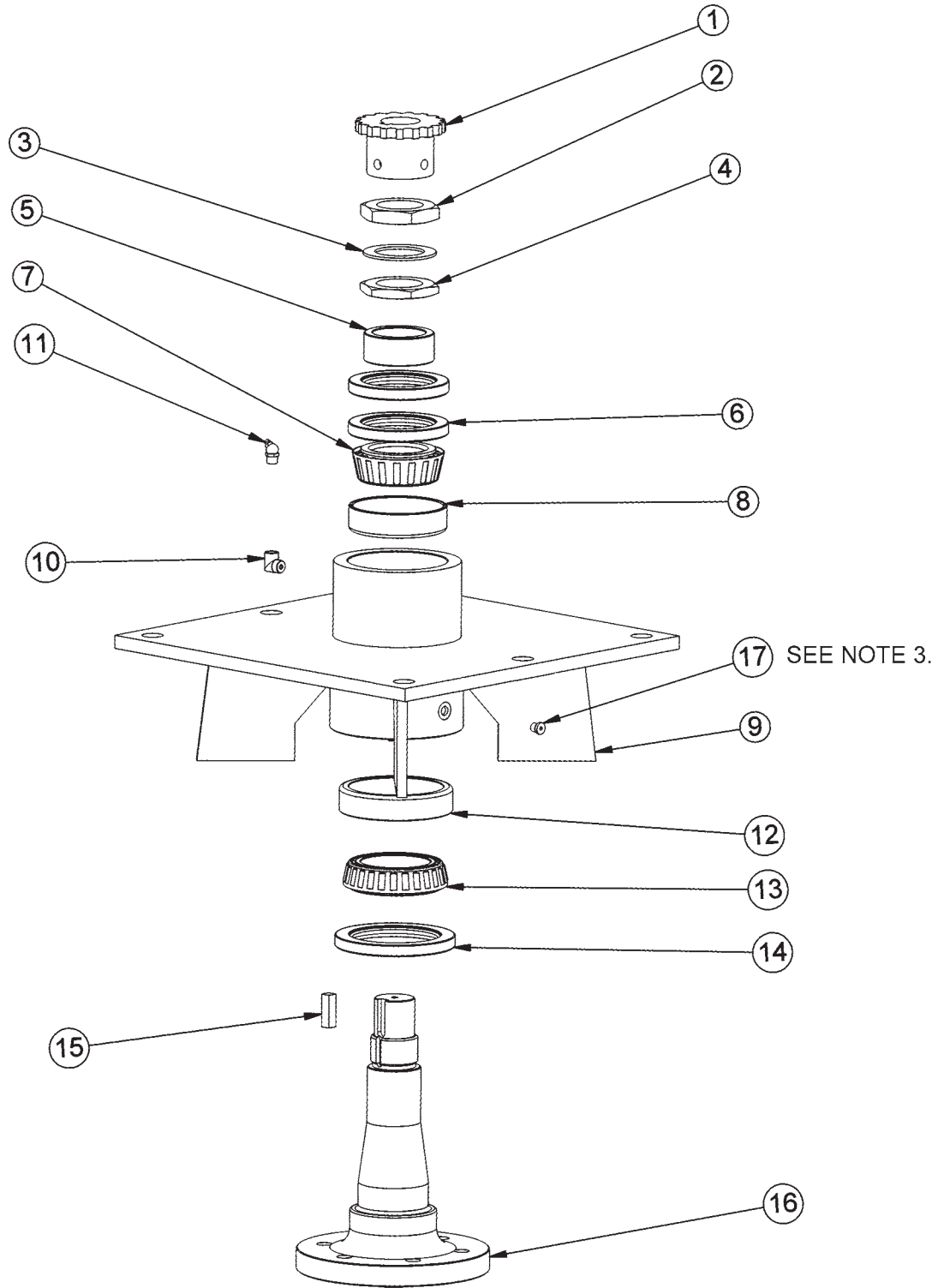

**NOTES:**

1. FREEPLAY: .001" - .003"
2. GREASE: FILL WITH MOBILITH SHC 220.
3. APPLY LOCTITE "271" TO O-RING PLUG THRDS.

# ROTARY SPINDLE ASSEMBLY

ITEM	PART NO.	QTY.	DESCRIPTION
1	6T1031	1	SPROCKET
2	6T1016	1	BEARING LOCKNUT - THICK
3	22596	1	JAM WASHER
4	6T1015	1	BEARING ADJUSTMENT NUT - THIN
5	6T1014	1	BEARING ADJUSTMENT SLEEVE
6	6T1011	1	UPPER SEAL - SET OF 2
7	6T1012	1	BEARING CONE
8	6T1013	1	BEARING CUP
9	33423	1	SPINDLE HOUSING
10	30570	1	STREET ELBOW
11	6T3208	1	GREASE ZERK
12	6T1013H	1	BEARING CUP
13	6T1012H	1	BEARING CONE
14	6T1011H	1	LOWER SEAL
15	6T1019	1	SPINDLE KEY
16	PT1018H5	1	SPINDLE
17	06503064	1	O-RING PLUG, 1/8"

# CHEETAH FLAIL HEAD ASSY.

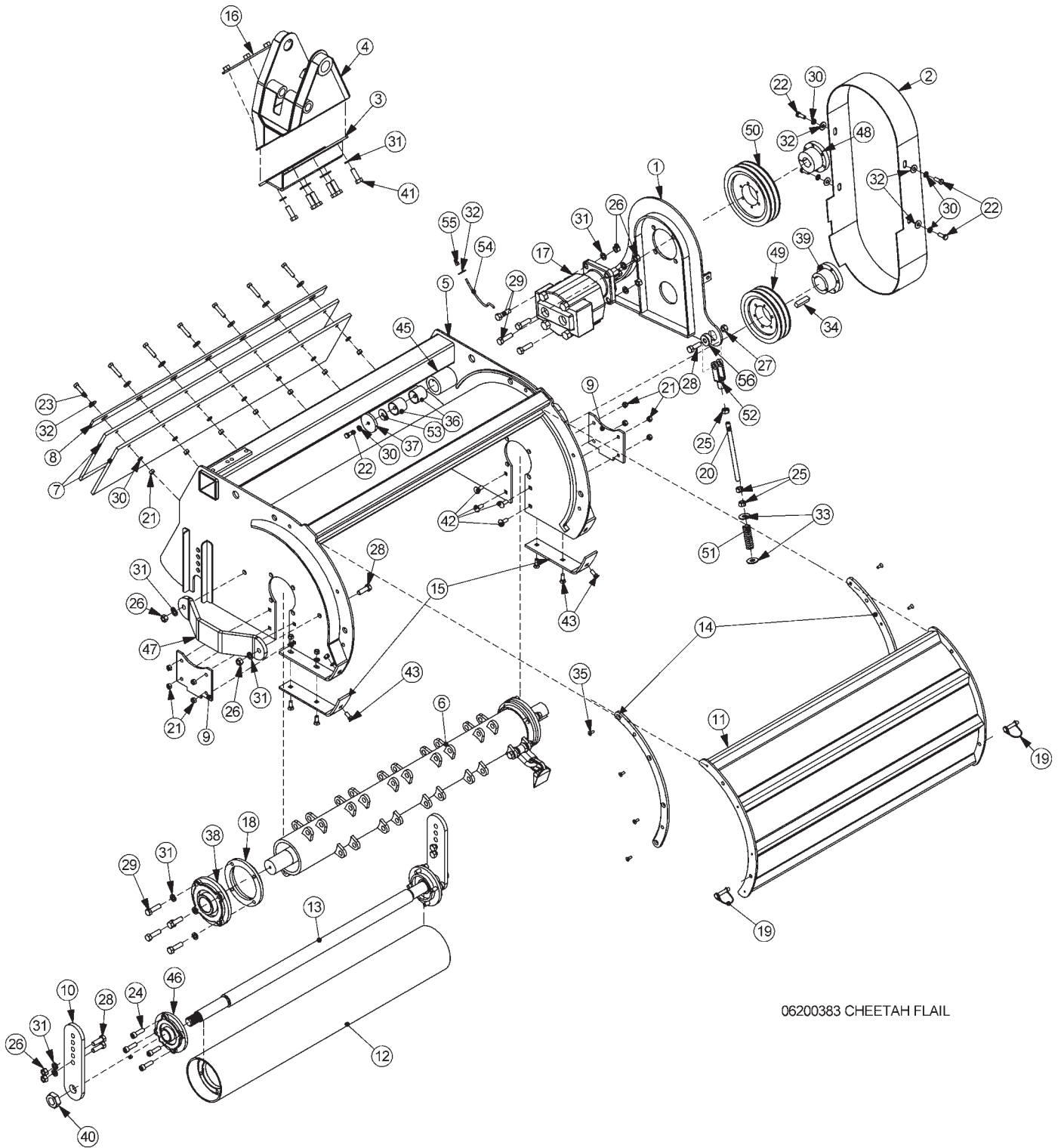

06200383 CHEETAH FLAIL

# CHEETAH FLAIL HEAD ASSY.

ITEM	P/N	QTY	DESCRIPTION
1	33808	1	MOUNT,DRIVE,CHEETAH,FLAIL
2	33806	1	SHIELD,DRIVE,CHEETAH,FLAIL
3	33805	1	MOUNT,PLATE,TREE,TBFS-40H
4	33804	1	MOUNT,TREE,CHEETAH,FLAIL
5	33803	1	TBFS-40H,WLDMNT,BONNET
6	<b>33801</b>	<b>1</b>	<b>CUTTERSHAFT,ASSY,BRUSH,CHEETAH</b>
*	<b>33802</b>	<b>1</b>	<b>CUTTERSHAFT,ASSY,GRASS,CHEETAH, (OPTIONAL)</b>
7	33797	2	FLAP,DEFLECTOR,CHEETAH,FLAIL
8	33796	1	RETAINING BAR,FLAP,CHEETAH,FLAIL
9	33795	2	CAP,SLOT,CHEETAH,FLAIL
10	33794	2	ADJ BRKT,GROUND ROLLER,CHEETAH,FLAIL
11	33793	1	SHIELD,SFTY,CHEETAH,FLAIL
12	33792	1	GROUND ROLLER,CHEETAH
13	33791	1	GROUND ROLLER,SHAFT,CHEETAH
14	33790	2	RUNNER,POLY
15	33789	2	SKID SHOE,CHET,FLAIL
16	33787	1	BAR,NUT PLATE
17	<b>06504019</b>	<b>1</b>	<b>CURRENT MOTOR,TBF 40S-H (END PORTING)</b>
	33868	1	ORIGINAL MOTOR,TBF 40S-H (END PORTING)
18	33863	2	STRING GUARD,STD
19	33906	2	PIN,LINCH,3/8x2,LOOP
20	40496	1	ROD,THREADED,1/2"NFx8"
21	21625	21	HEX NUT,3/8",NC
22	21630	5	CAPSCREW, 3/8 x 1,NC
23	21633	7	CAPSCREW, 3/8 x 1 3/4,NC
24	6T2330	8	CAPSCREW, 7/16 x 1 1/2, SOCKET HEAD
25	21700	3	HEX NUT, 1/2", NF
26	21725	10	HEX NUT, 1/2" NC
27	21727	1	NYLOCK NUT, 1/2
28	21731	7	CAPSCREW, 1/2 X 1 1/2,NC
29	21732	12	CAPSCREW, 1/2 x 1 3/4,NC
30	21988	18	LOCKWASHER, 3/8"
31	21990	24	LOCKWASHER, 1/2"
32	22016	12	FLATWASHER,3/8"
33	22018	3	FLATWASHER,1/2",WIDE
34	26142A	1	KEY,1/2" x 1/2" x 2"
35	27486	8	CAPSCREW,FLT/SKD HD,1/4x5/8NF
36	27580	2	BEARING,DX,1-1/2",GRM
37	28682	1	RETAINING,WASHER 2-1/2 X 5/16
38	28683	2	BEARING,FLANGE,1-15/16"STD TSF
39	28723	1	BUSHING,QD,SK 1-15/16
40	6T1023R	2	KNIFE MTG NUT,1-1/8" NYLOCK NF
41	6T2279	6	CAPSCREW, 1/2 X 1 1/2,NC,GR 8
42	6T2283	8	CARRIAGE BOLT,3/8" X 1"NC
43	6T2270	6	PLOW BOLT,3/8" X 1" NC
44	6T3204	2	GREASE ZERK,1/4" X STR
45	6T3207	2	GREASE ZERK,1/4" X STR
46	TF1022	2	BEARING,FLANGE,1-3/8"
47	TF1040	1	GUARD, CUTTER SHAFT
48	TF3013	1	BUSHING,QD,SK 1-1/4"
49	TF3040	1	SHEAVE,6.3
50	TF3044	1	SHEAVE,8.0
51	TF3620A	1	SPRING,TENSIONER
52	PT3611A	1	CLEVIS,6"
53	6T2615	1	WASHER,FENDER 3/8"
54	TF1032	1	HOSE,3/16" X 8"(1/8MP X 1/8MP)
55	TF1033	1	GREASE ZERK,1/8" FPT
56	TF3610	1	BUSHING
**	<b>TF3021</b>	<b>2</b>	<b>V-BELT,(560),(NOT SHOWN)</b>



# CHEETAH FLAIL - CUTTER SHAFT ASSY.

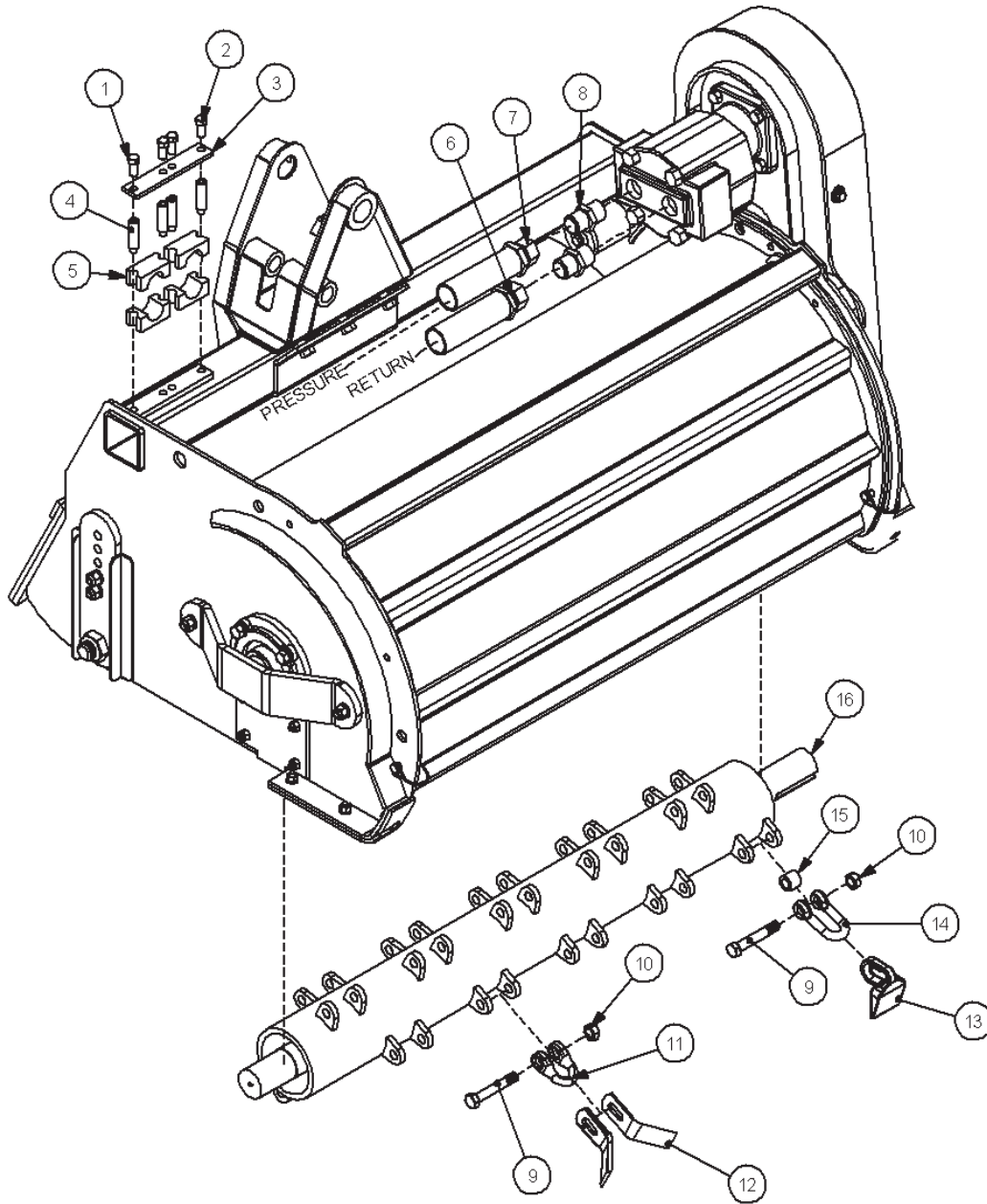

06200383 CUTTER SHAFT

## CHEETAH FLAIL - CUTTER SHAFT ASSY.

ITEM	P/N	QTY	DESCRIPTION
1	<b>31723</b>	1	<b>CLAMP KIT,TBF50</b>
2	21679	4	CAPSCREW, 7/16" X 1" NC
3	31955	1	PLATE, TOP, CLAMP, TBF
4	31916	4	POST, CLAMP, HOSE, 3000PSI
5	31917	4	CUSHION, CLAMP, HOSE, 3000PSI
6	33904	1	HOSE, 1" X 102" (FJX X FJX)
7	33905	1	HOSE, 1" X 94" (FJX X FJX)
8	33555	2	ADAPTER, 1" MORB X 1" MJIC
	<b>33802</b>	1	<b>CUTTERSHAFT, ASSY, GRASS, CHEETAH</b>
9	33925	20	CAPSCREW, 9/16 x 3.44, NC, GR 8 MOD
10	6T2419	20	HEX NUT, 9/16" NC, GR8
11	33736	20	CLEVIS, 1-9/16"x1/2" I.D.
12	33714	20	KNIFE, FLAIL, STANDARD
	<b>33801</b>	1	<b>CUTTERSHAFT, ASSY, BRUSH, CHEETAH</b>
13	33721	20	BLADE, BRUSH, FLAIL
14	33720	20	CLEVIS, 2-7/16" X 1/2" I.D.
15	33719	20	BUSHING, 1" O.D. X 5/8" I.D.
16	33800	1	CUTTERSHAFT, WELDMENT, CHEETAH
*	<b>33927</b>	2	<b>HOSE, SLEEVE, CHEETAH, FLAIL, SM (NOT SHOWN)</b>
*	<b>33928</b>	2	<b>HOSE, SLEEVE, CHEETAH, FLAIL, LG (NOT SHOWN)</b>
*	<b>6T123</b>	12	<b>ZIP TIES (NOT SHOWN)</b>

# CHEETAH FLAIL MOTOR

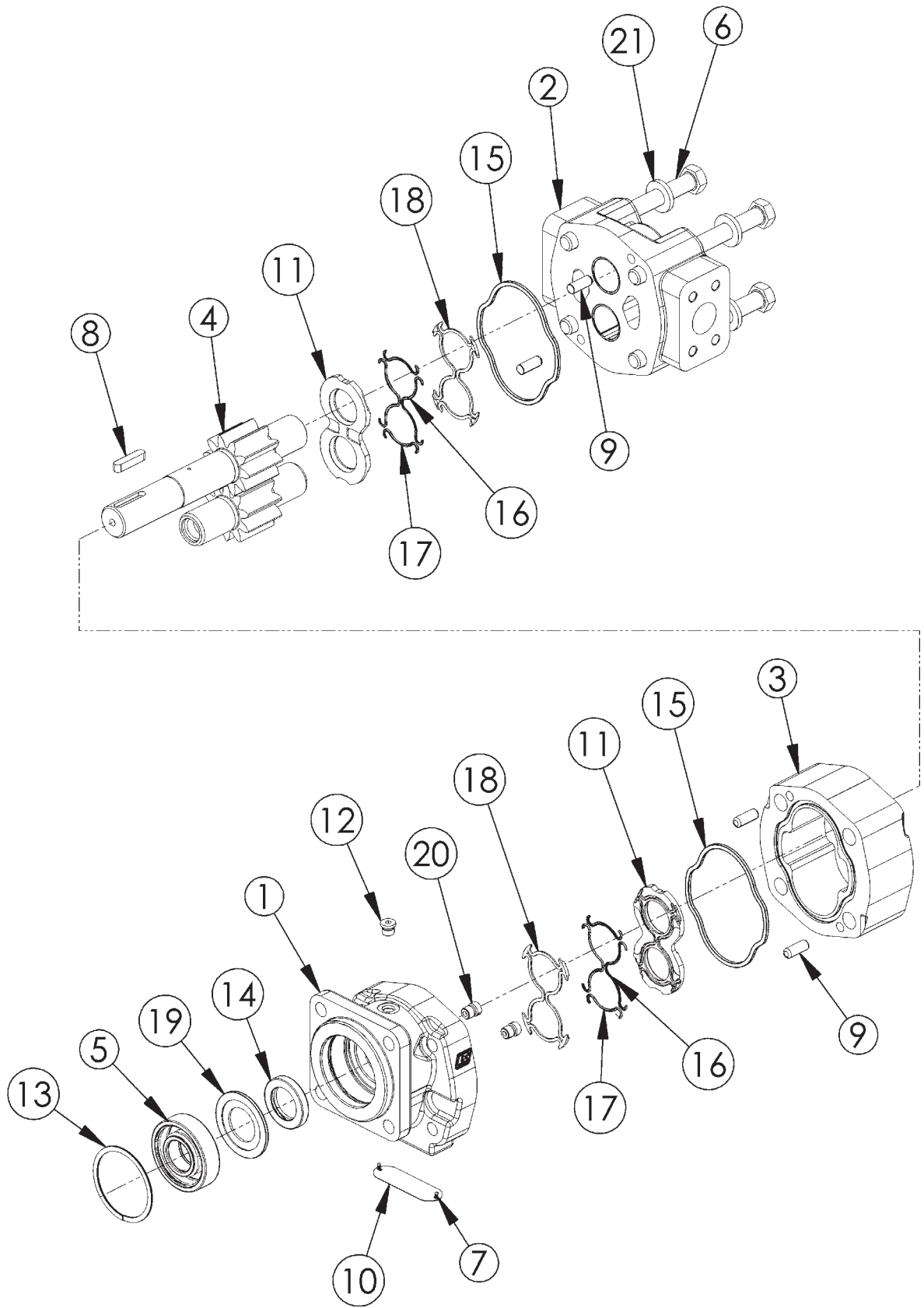

# CHEETAH FLAIL MOTOR

ITEM	PART NO.	QTY.	DESCRIPTION
*	<b>06504019</b>	<b>AVAIL</b>	<b>MOTOR ASSEMBLY 350 - CHEETAH FLAIL</b>
1	06504039	1	SHAFT END COVER
2	06504060	1	PORT END COVER
3	06504041	1	GEAR HOUSING
4	06504042	1	MATCHED GEAR SET
5	TF4402	1	BALL BEARING
6	06504043	4	CAP SCREW
7	06504044	2	SET SCREW
8	06504028	1	KEY
9	06504045	4	DOWEL PIN
10		1	NAMEPLATE
11	763759	2	THRUSTPLATE
12	02961940	1	HEX PLUG
13	TF4401	1	SNAP RING
14	06504049	1	LIP SEAL (INCLUDED IN SEAL KIT)
15	TF4410	2	GASKET SEAL (INCLUDED IN SEAL KIT)
16	06504046	4	SIDE SEAL (INCLUDED IN SEAL KIT)
17	06504047	4	END SEAL (INCLUDED IN SEAL KIT)
18	TF4407	2	BACK-UP SEAL (INCLUDED IN SEAL KIT)
19	06504048	1	SEAL RETAINER
20	6T5809	2	CHECK ASSEMBLY
21	02961917	4	WASHER
*	06504023	AVAIL	SEAL KIT (INCLUDES 14, 15, 16, 17, AND 18)

# CHEETAH CYLINDER BREAKDOWNS

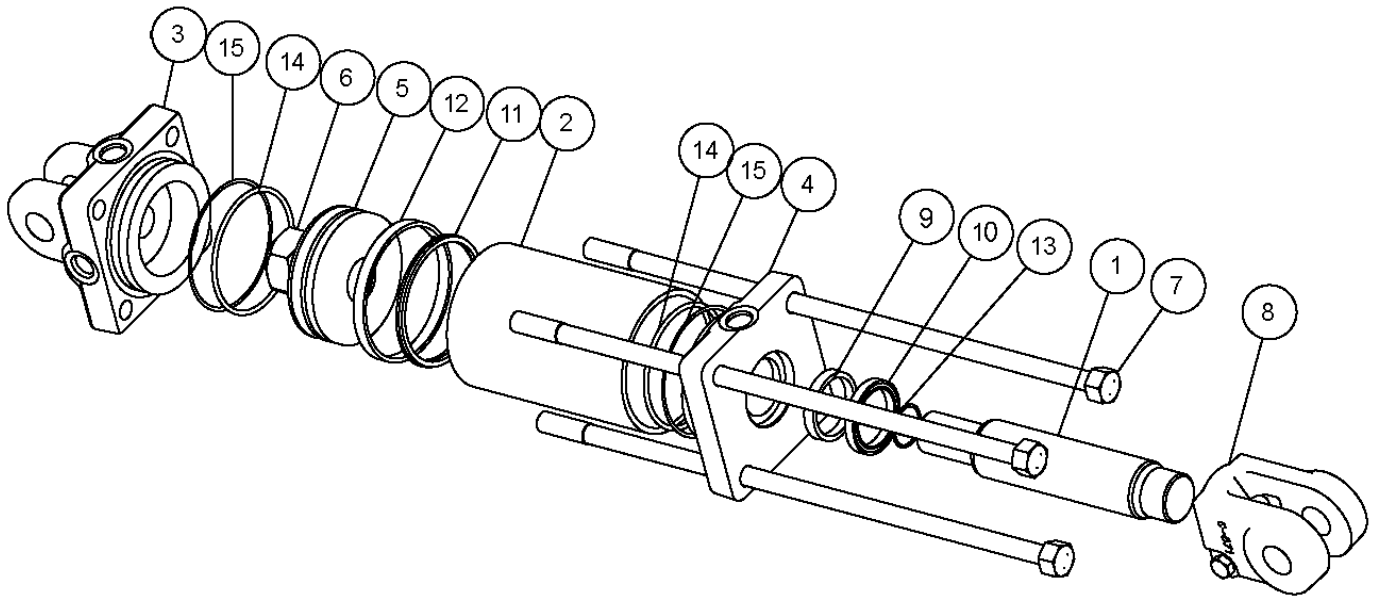

# CHEETAH CYLINDER BREAKDOWNS

## 2" X 6" CYLINDER # 6T7022

ITEM	PART NO.	QTY.	DESCRIPTION
1	6T0162D	1	PISTON ROD
2	6T0165D	1	CYLINDER TUBE
3	6T0167D	1	CYLINDER BUTT
4	6T0170D	1	CYLINDER GLAND
5	6T0173D	1	PISTON
6	6T0179D	1	LOCK NUT
7	6T0176D	4	TIE-ROD ASSY
8	6T0178D	1	CLEVIS ASSY
	<b>6T0187D</b>	<b>AVAIL</b>	<b>SEAL KIT</b>
9	*	1	U-CUP
10	*	1	WIPER
11	*	1	CROWN SEAL
12	*	N/A	N/A
13	*	1	O-RING
14	*	2	O-RING
15	*	1	BU-WASHER

## 2 1/2" X 12" CYLINDER # 33731

ITEM	PART NO.	QTY.	DESCRIPTION
1	33833	1	PISTON ROD
2	33834	1	CYLINDER TUBE
3	33835	1	CYLINDER BUTT
4	33836	1	CYLINDER GLAND
5	33837	1	PISTON
6	33838	1	LOCK NUT
7	33840	4	TIE-ROD ASSY
8	33842	1	CLEVIS ASSY
	<b>33843</b>	<b>AVAIL</b>	<b>SEAL KIT</b>
9	*	1	U-CUP
10	*	1	WIPER
11	*	1	CROWN SEAL
12	*	N/A	N/A
13	*	1	O-RING
14	*	2	O-RING
15	*	1	BU-WASHER

## 2 1/2" X 11 1/2" CYLINDER # 34275

ITEM	PART NO.	QTY.	DESCRIPTION
1	06501576	1	PISTON ROD
2	06501575	1	CYLINDER TUBE
3	06501574	1	CYLINDER BUTT
4	33836	1	CYLINDER GLAND
5	33837	1	PISTON
6	33838	1	LOCK NUT
7	06501577	4	TIE-ROD ASSY
8	N/A	N/A	CLEVIS ASSY
	<b>06501578</b>	<b>AVAIL</b>	<b>SEAL KIT</b>
9	*	1	U-CUP
10	*	1	WIPER
11	*	1	CROWN SEAL
12	*	N/A	N/A
13	*	1	O-RING
14	*	2	O-RING
15	*	1	BU-WASHER

# CHEETAH CYLINDER BREAKDOWNS

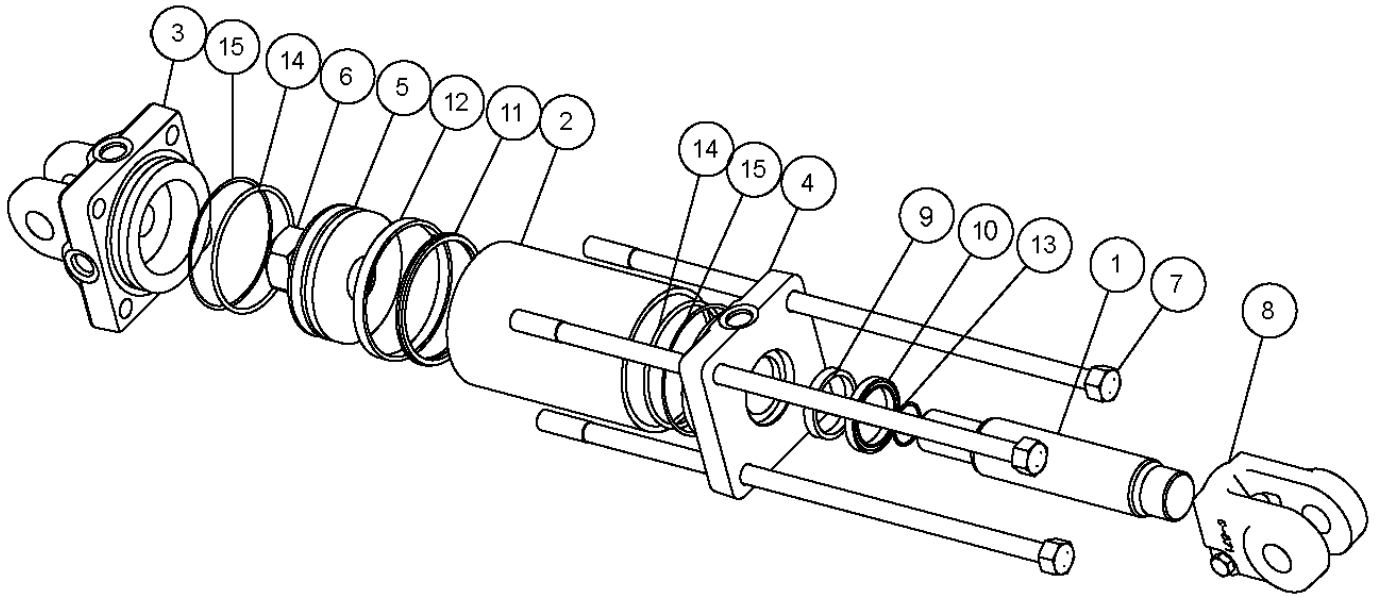



# CHEETAH CYLINDER BREAKDOWNS

## 3 1/2" X 14" CYLINDER # 33703

ITEM	PART NO.	QTY.	DESCRIPTION
1	33822	1	PISTON ROD
2	33823	1	CYLINDER TUBE
3	33824	1	CYLINDER BUTT
4	33825	1	CYLINDER GLAND
5	33826	1	PISTON
6	33827	1	LOCK NUT
7	33829	4	TIE-ROD ASSY
8	6T0178	1	CLEVIS ASSY
	<b>33832</b>	<b>AVAIL</b>	<b>SEAL KIT</b>
9	*	1	U-CUP
10	*	1	WIPER
11	*	1	CROWN SEAL
12	*	N/A	N/A
13	*	1	O-RING
14	*	2	O-RING
15	*	1	BU-WASHER

## 4" X 14" CYLINDER # 33702

ITEM	PART NO.	QTY.	DESCRIPTION
1	33814	1	PISTON ROD
2	33816	1	CYLINDER TUBE
3	6T0169	1	CYLINDER BUTT
4	6T0171	1	CYLINDER GLAND
5	33817	1	PISTON
6	6T0175	1	LOCK NUT
7	33819	4	TIE-ROD ASSY
8	6T0172	1	CLEVIS ASSY
	<b>33821</b>	<b>AVAIL</b>	<b>SEAL KIT</b>
9	*	1	U-CUP
10	*	1	WIPER
11	*	1	CROWN SEAL
12	*	1	BEARING RING
13	*	1	O-RING
14	*	2	O-RING
15	*	1	BU-WASHER

# RESERVOIR TANK FILTER ASSEMBLY

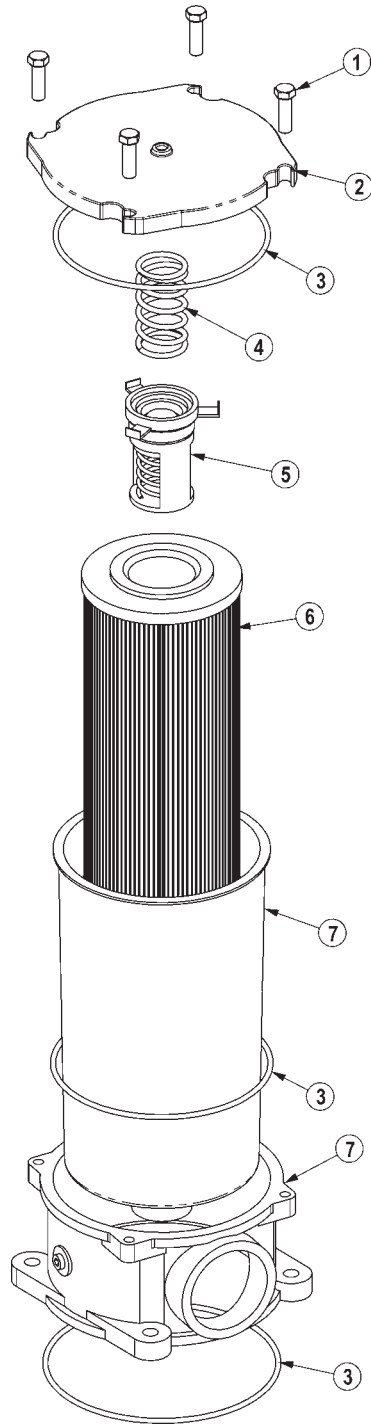

ITEM	PART NO.	QTY.	DESCRIPTION
	<b>06505044</b>	<b>AVAIL</b>	<b>FILTER ASSY SAE 10 MICRON</b>
1	28583	4	CAPSCREW,8MMX25MM(1.25 PITCH)
2	06505045	1	COVER
3	06505046	1	SEAL KIT
4	06505047	1	SPRING
5	06505048	1	BYPASS
6	35259	1	FILTER,10 MIC,RETURN LINE
7	06505049	1	CAN/BODY

# BRAKE VALVE ASSEMBLY W/ METRI PAK

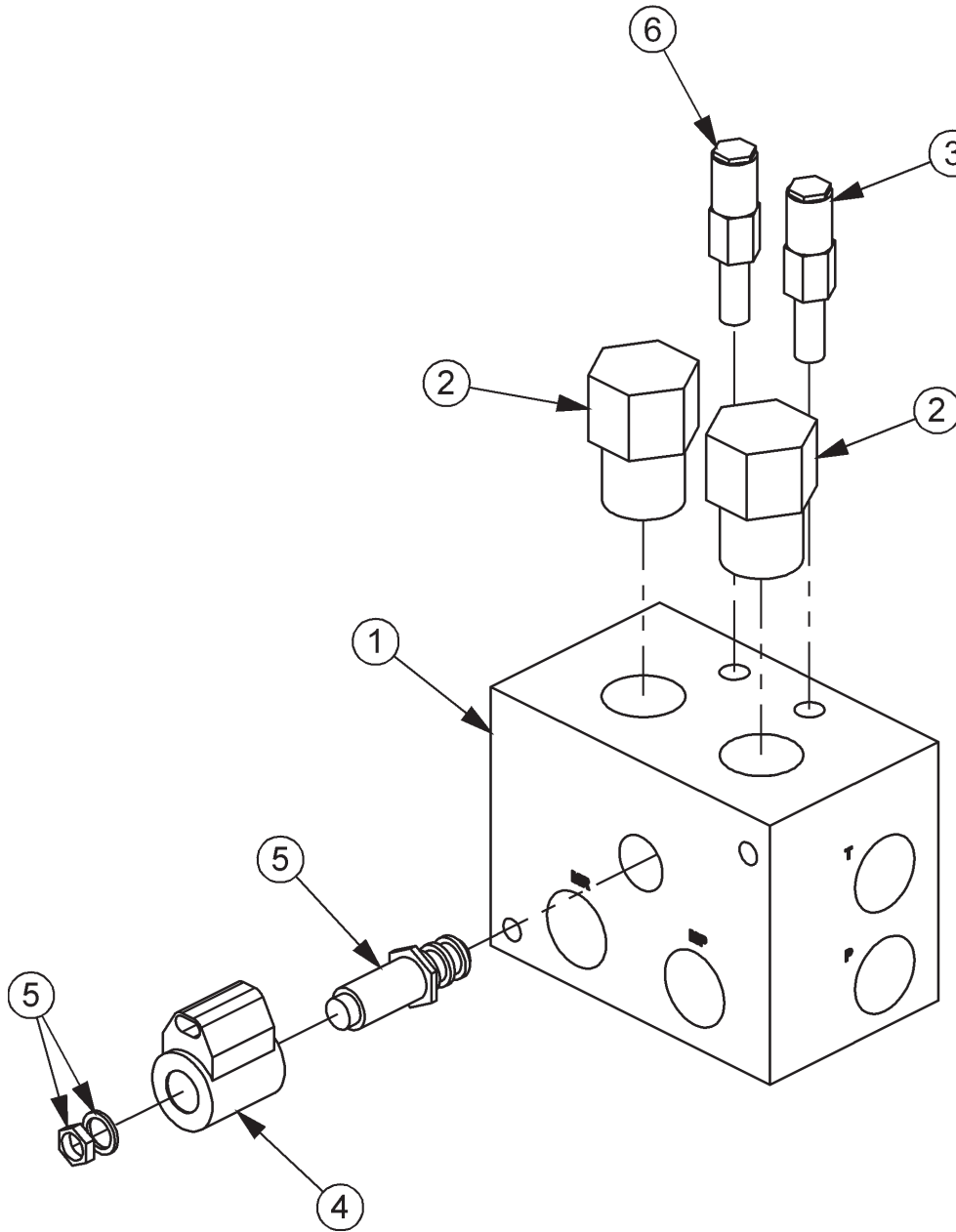

ITEM	PARTNO.	QTY.	DESCRIPTION
1	34092	1	BRAKE VALVE, BLANK
2	34095	1	RELIEF VALVE, 3000 PSI
3	34094	2	LOGIC ELEMENT
4	06510095	1	METRI PAK COIL
5	34093	1	CARTRIDGE, 2 POSITION, 3 WAY (WITH NUT & WASHER)

# BOOM TRAVEL LOCK

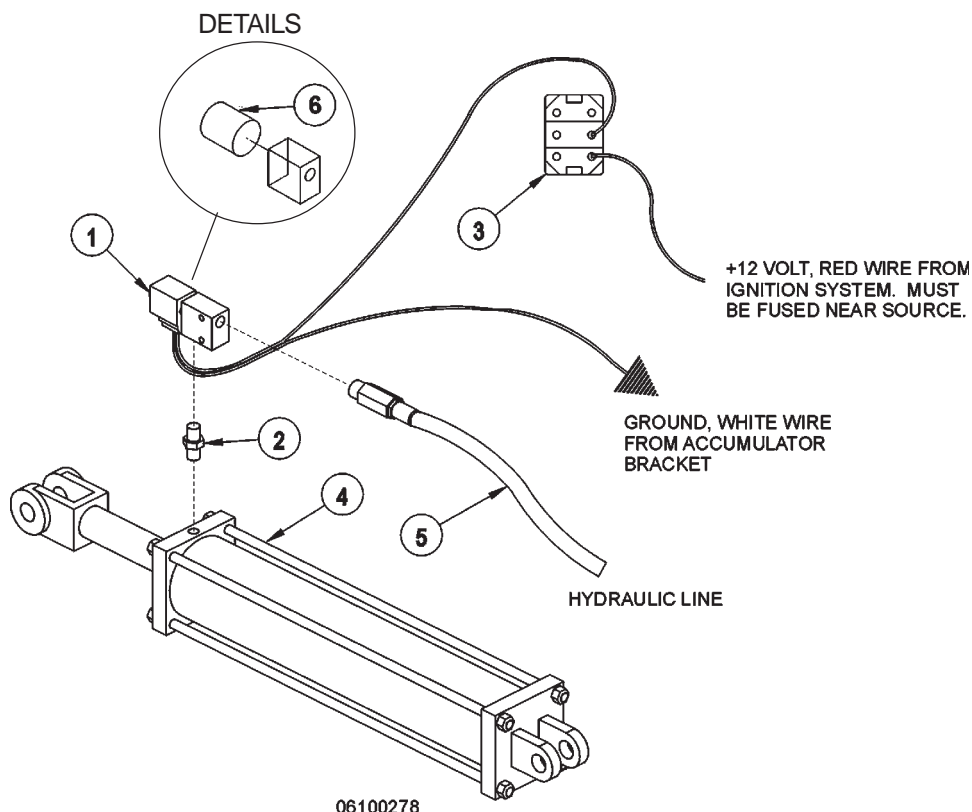

Danfoss Switch Box



TRAVEL LOCK SWITCH

Husco Switch Box



TRAVEL LOCK SWITCH

**OLDER UNITS ONLY, SWITCH ON NEWER MODELS IN SWITCHBOX**  
**Refer to your switchbox before drilling hole or wiring.**

For cab units, drill a hole in an open area on the right side of the dash panel and install the toggle switch. For non-cab units, use the mounting bracket included to install the toggle switch on the under side of the valve stand. Install the decal for the toggle switch operation directly by the toggle switch.

ITEM	PART NO.	QTY.	DESCRIPTION
1	31328	1	HYDRAULIC TRAVEL LOCK VALVE
2	31329	1	ADAPTER - STANDARD BOOM
2A	31611	OPT.	ADAPTER - EXTENDED BOOM
3	34532	1	SWITCH, TRAVEL LOCK
4	*	REF.	MAIN BOOM CYLINDER - REFER OT BOOM ASY
5	*	REF.	HOSE / FITTINGS - REFER TO BOOM ASY
6	34796	1	COIL, TRAVEL LOCK

# SOLENOID BRAKE VALVE HYDRAULIC SCHEMATIC

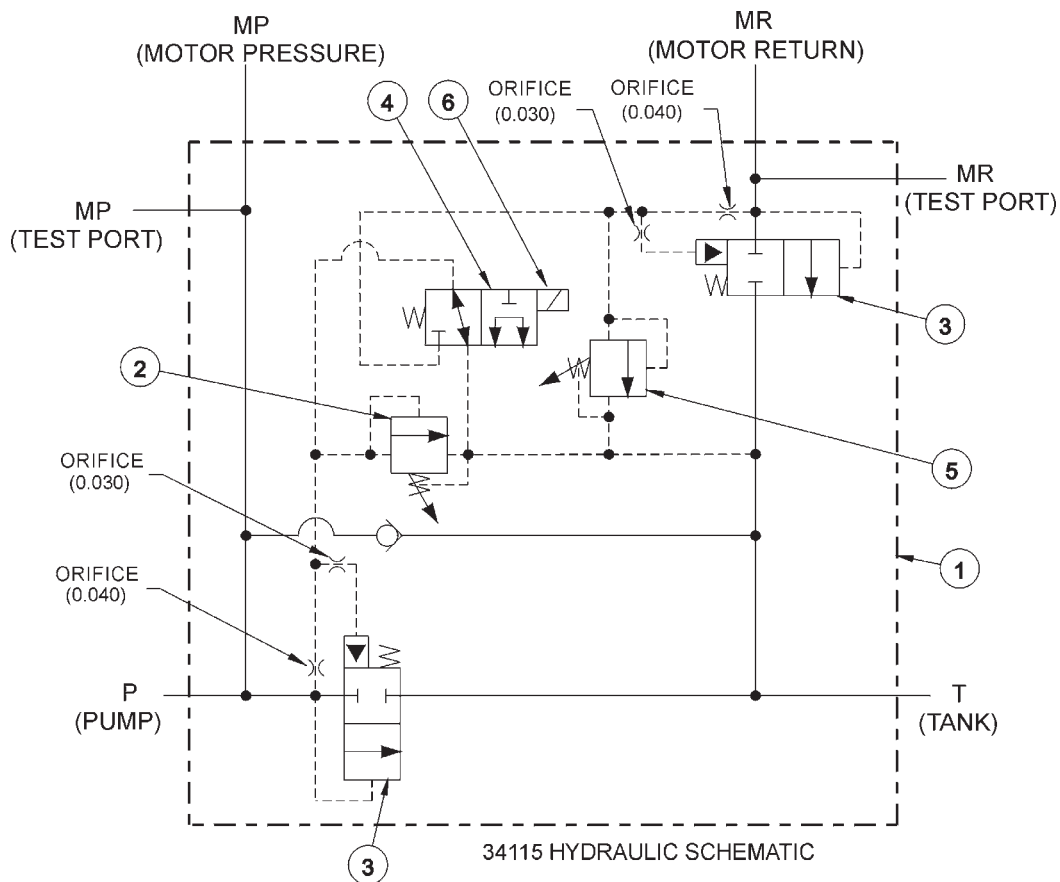

## BRAKE VALVE TROUBLESHOOTING

### FAILURE MODE:

- MOWER WILL NOT START - system pressure is low (engine not lugging).
- MOWER WILL NOT START - system pressure is high (engine lugging). "MR" port will be high pressure.
- MOWER WILL NOT ROTATE AT FULL SPEED - limited power.
- MOWER BLADE WILL NOT STOP - blade will not stop in proper time.

### CHECK STEPS

- 1 thru 6
- 7
- 3 thru 5
- 7 thru 9

### CORRECTIVE STEPS:

1. Check for voltage at solenoid (item 6), voltage must be between 10.2 volts and 13.8 volts.
2. Remove, inspect solenoid and cartridge (items 4, 6) for wear or contamination.
3. Remove, inspect logic elements near "P" port (item 3) for wear or contamination.
4. Remove, inspect 3000 psi relief valve (item 2) for wear or contamination.
5. Remove and inspect orifices near "P" port for contamination.
6. Remove "P" port hose and fitting, visually inspect for contamination, check ball for movement.
7. Remove and inspect orifices near "MR" port for contamination.
8. Remove, inspect 2600 psi relief valve (item 5) for wear of contamination.
9. Remove, inspect logic element near "MR" port (item 3) for wear or contamination.

# JOYSTICK SWITCHBOX SERVICE PARTS

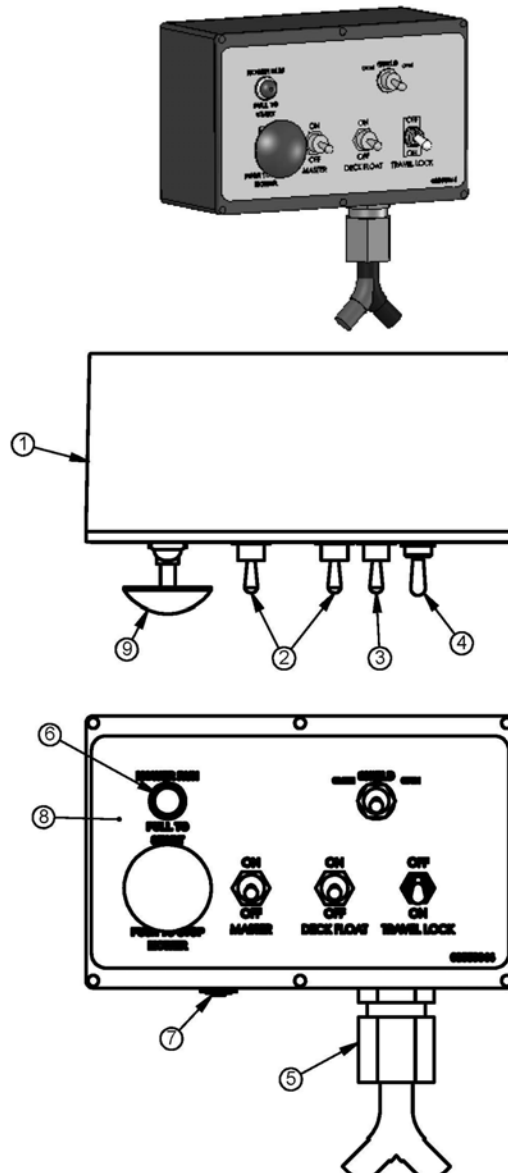

ITEM	P/N	QTY.	DESCRIPTION
1	06510196	1	SWBX,ASSY
2	33811	2	SWITCH,MASTER/DECK FLOAT
3	33813	1	SWITCH,SFTY SHIELD
4	34532	1	SWITCH,TRVL LCK
5	34540	1	STRAIN RELIEF,3/4,BLACK,NYLON
6	6T3923	1	INDICTATOR LIGHT,ON,RED
7	06514006	1	BREAKER,15A,SWBX
8	06550044	1	DECAL,SWBX,06510047
9	35226	1	SWITCH,MOWER,COLEHERSEE
10	35227	1	RELAY,DP,DT,12V,LY2F,35226

# JOYSTICK SWITCHBOX SCHEMATIC (06510196)

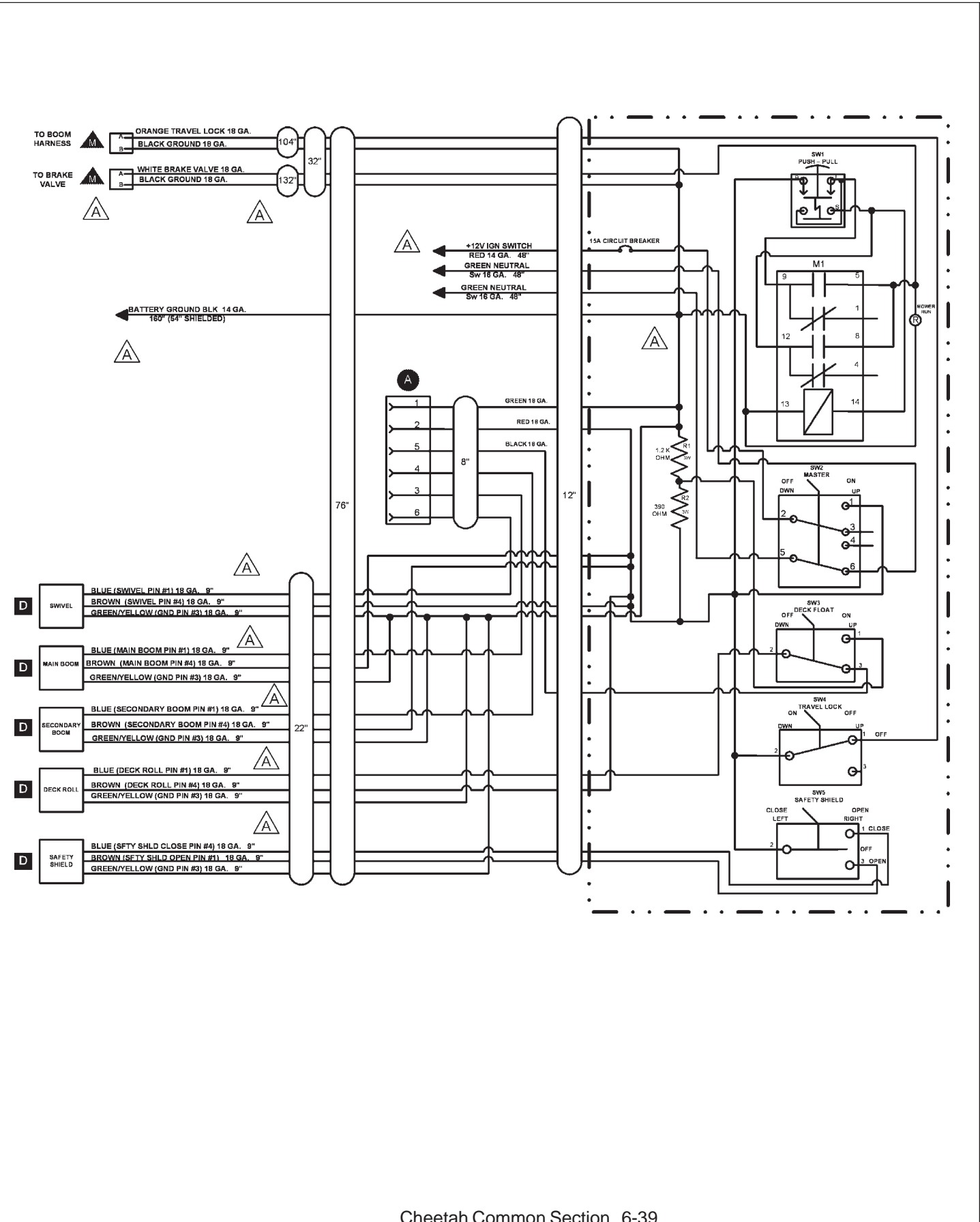



# HUSCO CONTROLS SWITCHBOX

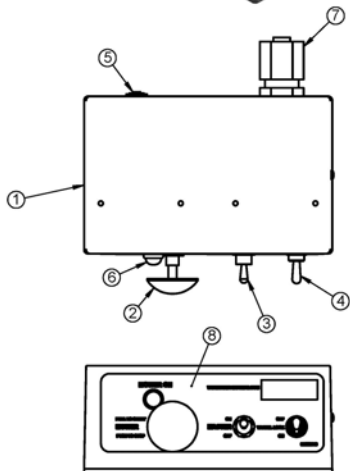
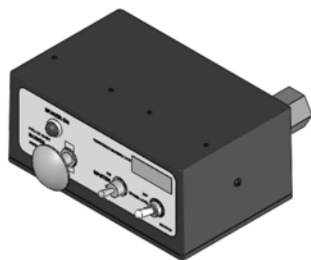
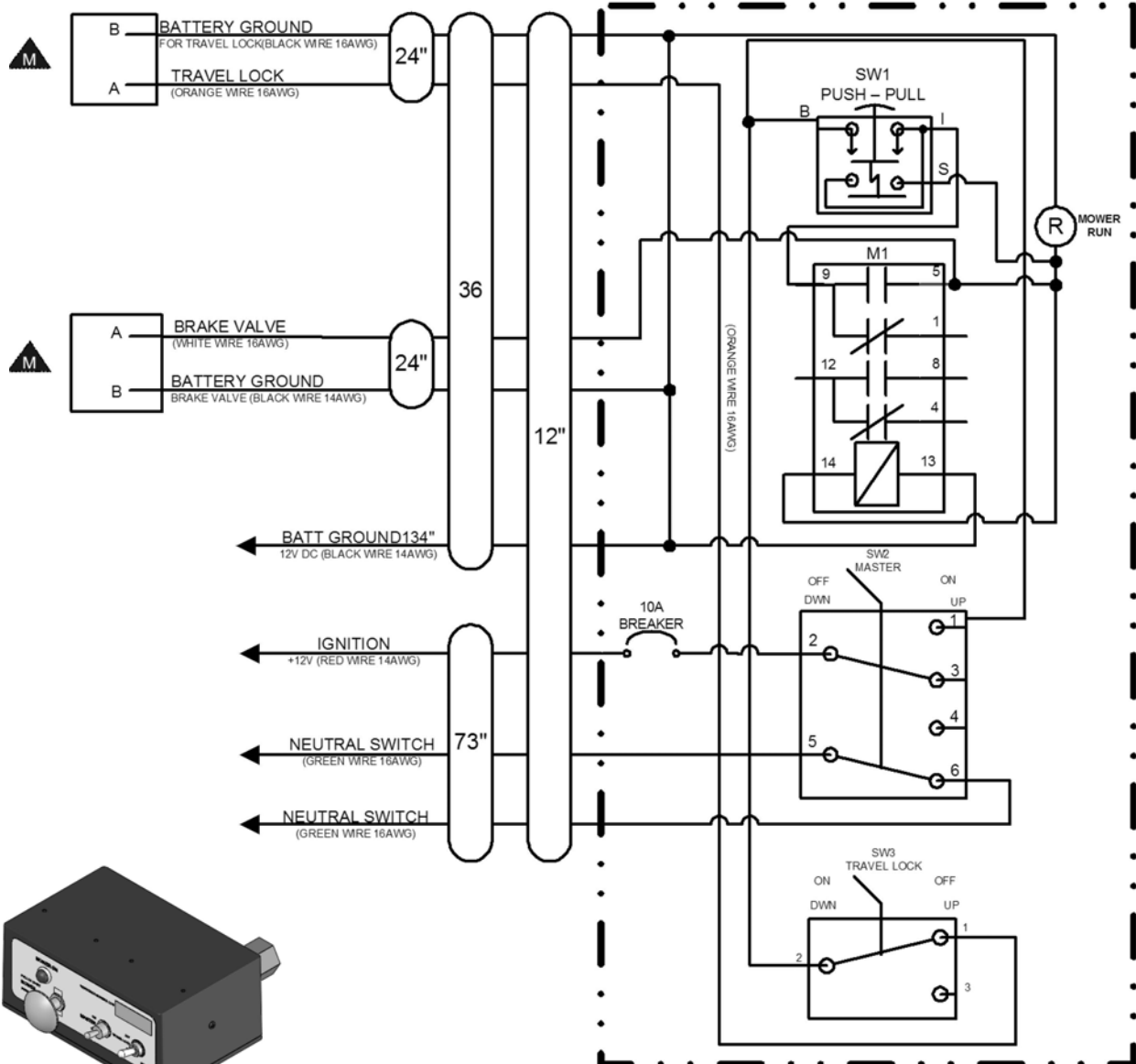

ITEM	P/N	QTY.	DESCRIPTION
1	06514012	1	SWBX,ALUM,BLK,06510100
2	35226	1	SWITCH,MOWER,COLEHERSEE
3	33811	1	SWITCH,MASTER/DECK FLOAT
4	34532	1	SWITCH,TRVL LCK
5	06514014	1	BREAKER,10A,SWBX
6	6T3923	1	INDICTATOR LIGHT,ON,RED
7	34540	1	STRAIN RELIEF,3/4,BLACK,NYLON
8	06550019	1	DECAL,SWTCHBX,BOOM,CG
9	35227	1	RELAY,DP,DT,12V,LY2F,35226

PAGE  
INTENSIONALLY  
LEFT  
BLANK

# OPTIONAL PUMP GUARD KIT

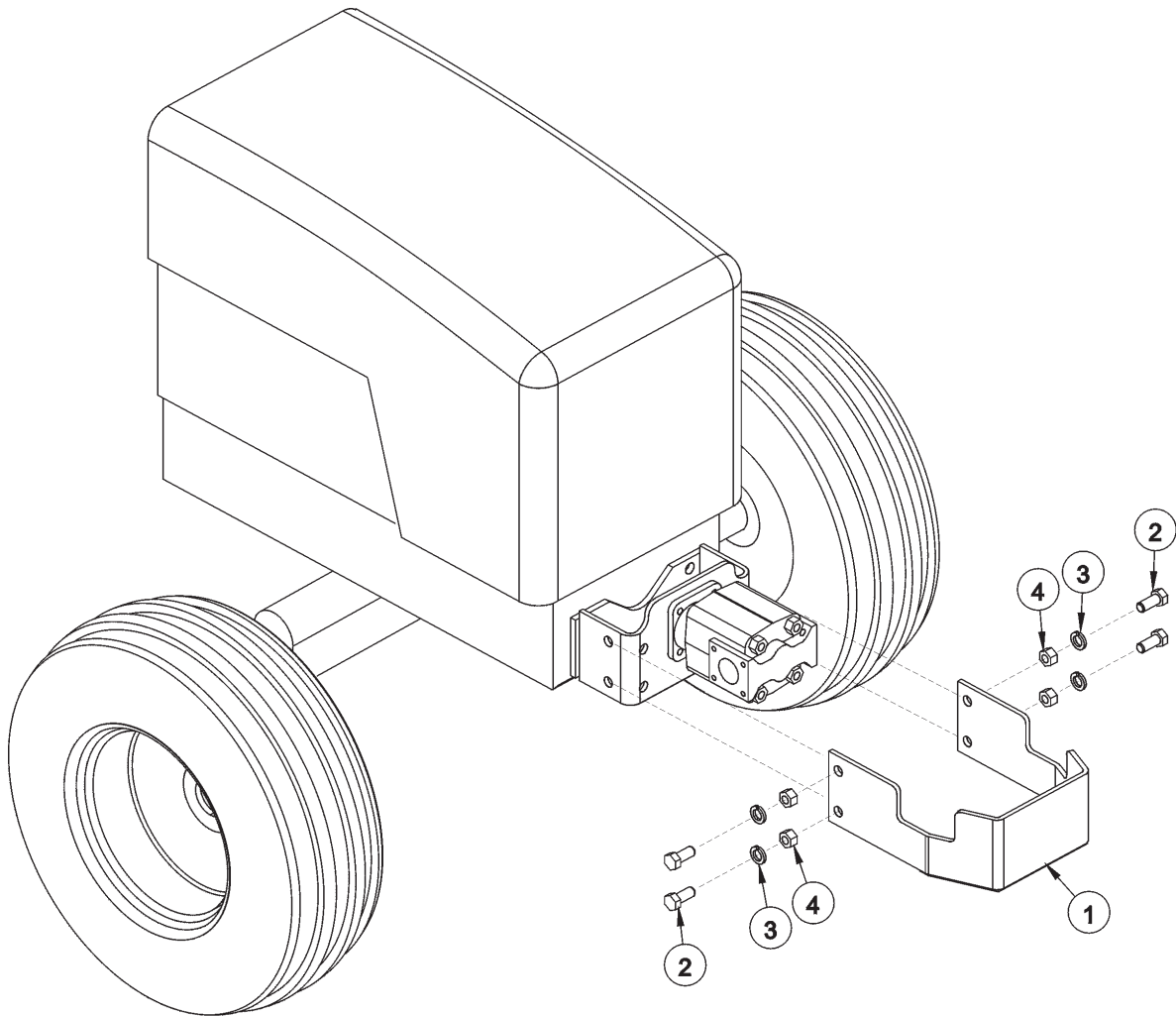

06200342

ITEM	PART NO.	QTY.	DESCRIPTION
1	32430	1	UNIVERSAL PUMP GUARD
2	21831	4	CAPSCREW - 3/4 X 1 3/4
3	21993	4	LOCKWASHER - 3/4
4	21825	4	HEX NUT - 3/4

# OPTIONAL PUMP AND GRILL GUARD KIT

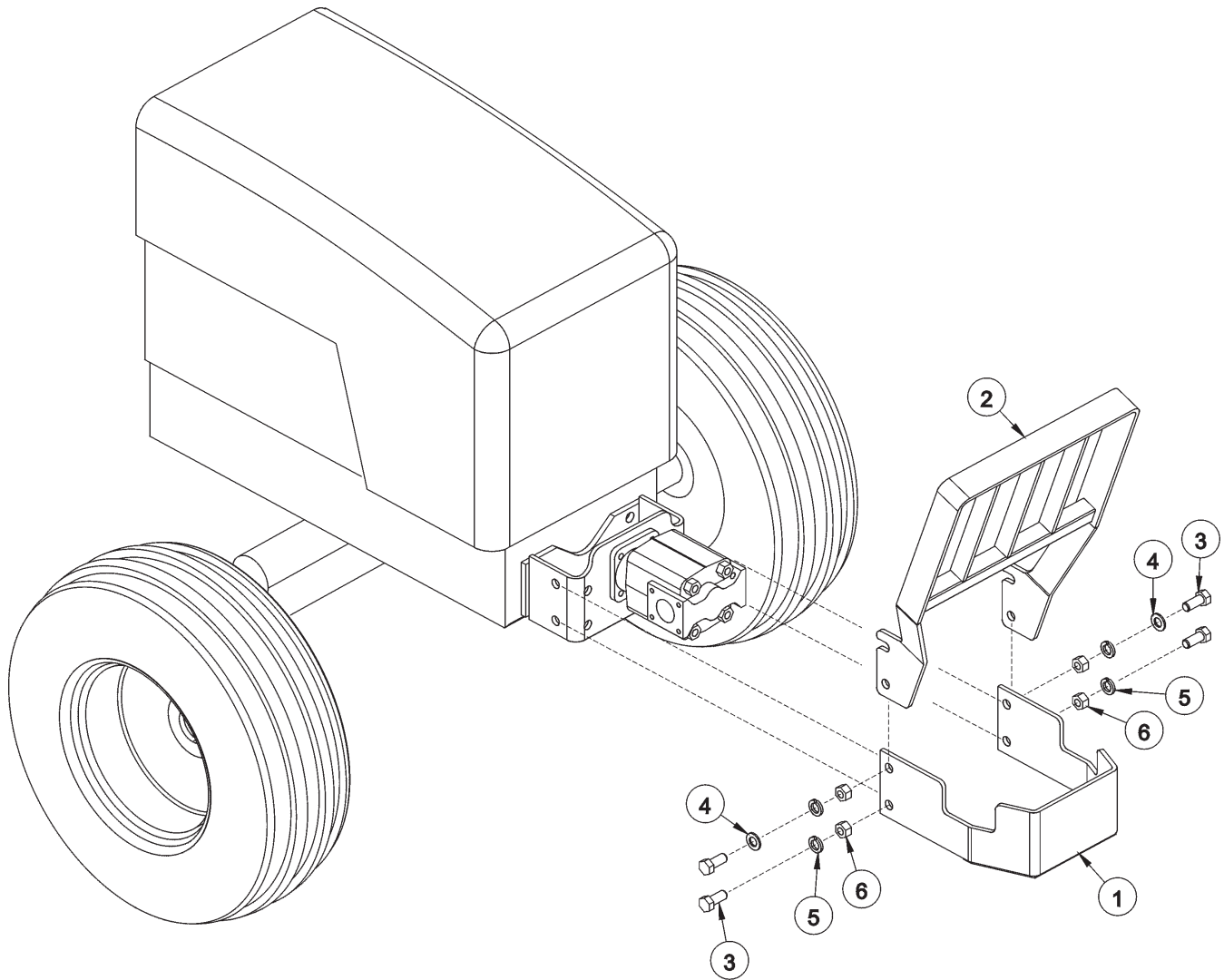

06200349

ITEM	PART NO.	QTY.	DESCRIPTION
1	32430	1	UNIVERSAL PUMP GUARD
2	32737	1	UNIVERSAL GRILL GUARD
3	21833	4	CAPSCREW - 3/4 X 2 1/4
4	22021	2	FLATWASHER - 3/4
5	21993	4	LOCKWASHER - 3/4
6	21825	4	HEX NUT - 3/4

# TROUBLESHOOTING

## JOYSTICK TROUBLESHOOTING

### **Boom operation not responding to joystick movement.**

Isolate hydraulic vs. electronic symptom.

Turn off electronic master switch (preventing electronic actuator on valve from attempting to hold spool in neutral position). With tractor engine running, operate the valve section with the manual handle. If function operates normally, continue with electronic inspection. If function does not operate normally, continue with hydraulic inspection.

### **Electronic inspection.**

Connect a voltmeter to the cable connector of the valve section that is not operating. This will allow you to measure supply and signal voltage when the joystick is operated.

Main, Secondary, and Swivel Valves – signal voltage should be 50% of supply voltage with joystick in Neutral position, up to 75% of supply voltage in B direction, down to 25% of supply voltage in A direction. Signal voltage should change smoothly with lever movement.

Pin #1 – Supply Voltage      Pin #2 – Signal Voltage      Pin #gnd – ground

Deck Roll Valve or Float Valve – signal voltage should be 50% of supply voltage with joystick in Neutral position, up to 65% of supply voltage in B direction, down to 35% of supply voltage in A direction. Signal voltage should change smoothly with lever movement. Signal voltage should be approximately 75% of supply voltage when float switch is operated.

Pin #1 – Supply Voltage      Pin #2 – Signal Voltage      Pin #gnd – ground

Shield Valve or On/Off Valve – Voltage on pin #1 should be equal to supply voltage when switch is operated in A direction. Voltage on pin #2 should be equal to supply voltage when switch is operated in B direction.

Pin #1 – Signal Voltage      Pin #2 – Signal Voltage      Pin #gnd – ground

If none of the valve will operate with electrical signal, verify that there is oil pressure at the valve inlet. Electrical Valves must have pilot supply oil to move the spools.

### **Possible electronic problems.**

Open circuit (broken wire, bad connection or loose connection in switch box).  
Shorted to positive, ground, or other.  
Incorrect voltage signal from joystick.

Continued on next sheet

# TROUBLESHOOTING

## Hydraulic inspection.

Install 3 pressure gauges, on the valve inlet (use M port, or tee into hose supplying oil from the pump to the inlet), on the workport that is not operating, and on the LS port.

With the spools in Neutral

Gear pump – P should be approximately 200 psi, LS = 0, workport – pressure on cylinder or function.

LS pump – P should equal pump standby pressure, LS = 0, workport – pressure on cylinder or function.

Pressure Comp pump – P should equal pump standby pressure, LS = 0, workport – pressure on cylinder or function.

Gear pump – P should be approximately 200 psi higher than LS, LS should equal workport, workport – pressure on cylinder or function.

LS pump – P should be LS + standby, LS should equal workport, workport – pressure on cylinder or function.

Pressure Comp pump – P should equal pump standby pressure, LS should equal workport, workport – pressure on cylinder or function.

Operate one spool, measure pressures with function at end of travel or stop

Gear pump – P should equal valve relief setting or workport shock valve setting. LS should equal workport. Workport should equal relief setting or workport shock valve setting.

LS pump – P should equal valve relief setting, pump max pressure setting, or workport shock valve setting. LS should equal workport. Workport should equal relief setting, pump max pressure setting, or workport shock valve setting.

Pressure Comp pump – P should equal pump standby pressure, LS should equal workport. Workport should equal pump standby pressure or workport shock valve setting.

Operate more than one spool.

Gear pump – P should approximately 200 psi higher than LS. LS should equal highest workport pressure. Workport – pressure on cylinder or function.

LS pump – P should be LS + standby pressure. LS should equal highest workport pressure. Workport – pressure on cylinder or function.

Pressure Comp pump. P should equal pump standby pressure. LS should equal highest workport pressure. Workport – pressure on cylinder or function.

## Possible hydraulic problems.

Cylinder leak.

LS signal leaking to tank before reaching pump LS port.

Hydraulic system or pump not supplying flow to valve.

# HYDRAULIC - TROUBLESHOOTING GUIDE

## Hydraulic Troubleshooting guide

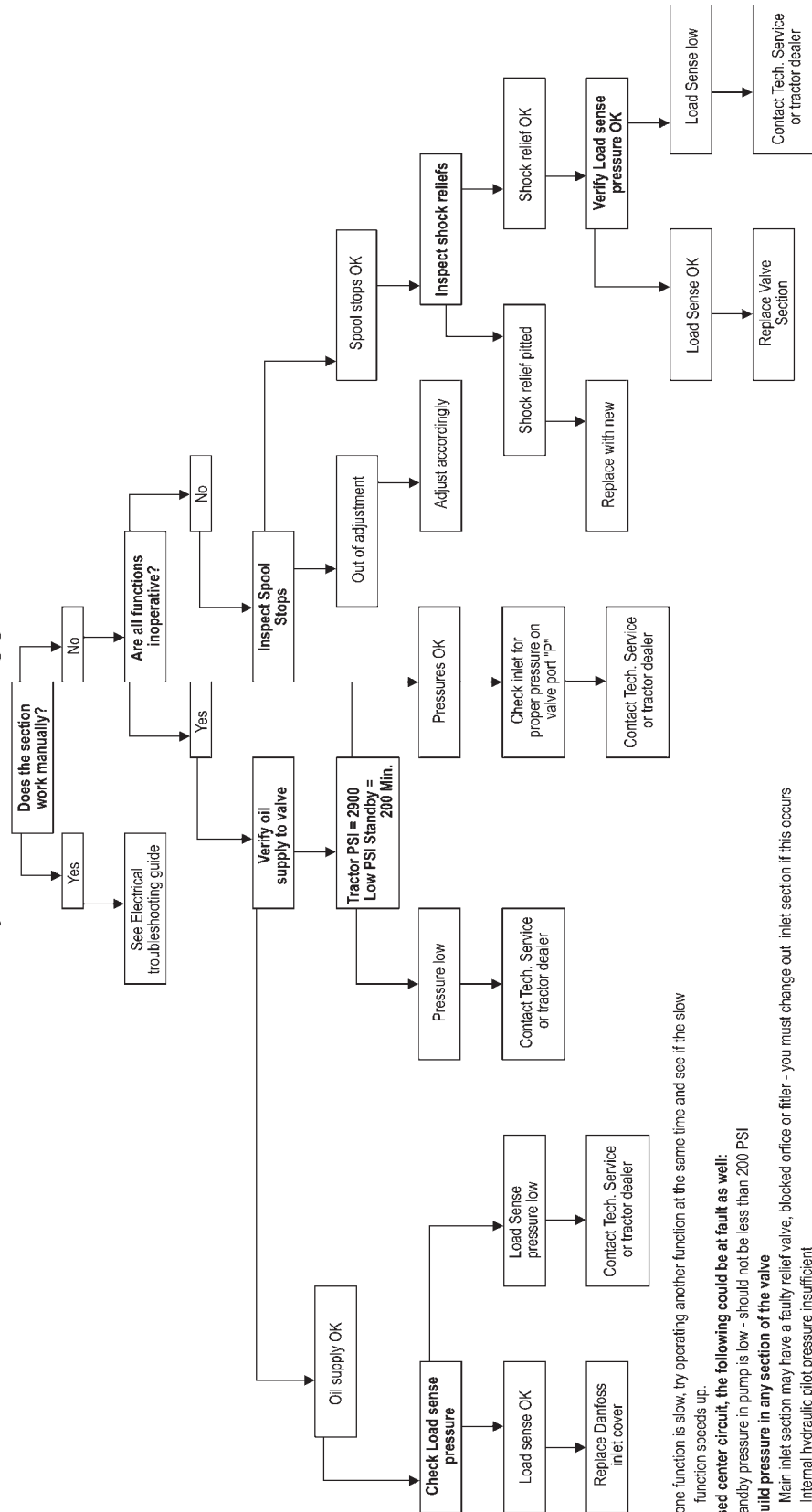

**Notes:** If one function is slow, try operating another function at the same time and see if the slow function speeds up.

**On a closed center circuit, the following could be at fault as well:**

Tractor standby pressure in pump is low - should not be less than 200 PSI

Cannot build pressure in any section of the valve

Main inlet section may have a faulty relief valve, blocked orifice or filter - you must change out inlet section if this occurs  
Internal hydraulic pilot pressure insufficient



# ELECTRICAL - TROUBLESHOOTING GUIDE

## Danfoss Electrical Troubleshooting guide

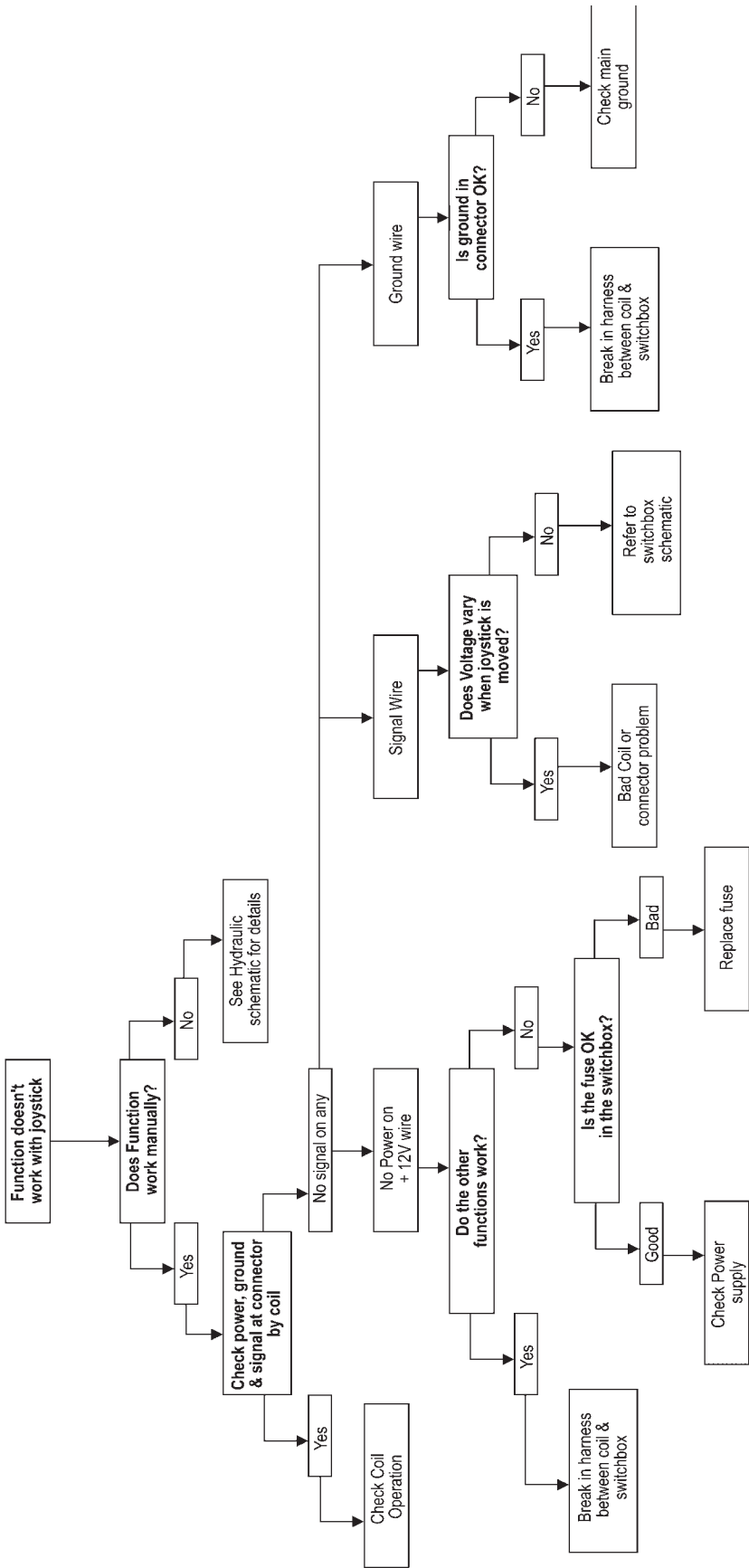

# NOTES

**WARRANTY  
SECTION**



## WARRANTY INFORMATION

Tiger Corporation, 3301 N. Louise, Sioux Falls, South Dakota, warrants to the original Retail Customer, the new Tiger equipment is free of defects in material and workmanship. Any part of equipment that in Tiger's judgement, show evidence of such defects will be repaired or replaced without charge, provided that the failure of part(s) shall have occurred within twelve (12) months from the date of delivery of said equipment to the Retail Customer. Expendable components such as knives, oil, chain sprockets, skid shoes, knife mounting disks and the like are excluded but not limited to this warranty.

The Retail Customer must pay the transportation cost to and from the Tiger Dealer's service shop for warranty service. Warranty service will be performed by the Tiger Dealer from whom the equipment was purchased, during service shop regularly scheduled days and hours of operation.

All Tiger obligation under this warranty shall be terminated if the equipment is modified or altered in ways not approved in writing by Tiger, if repair parts other than genuine Tiger repair parts have been used, or if the equipment has been subject to misuse, neglect, accident, improper maintenance or improper operation.

Tiger Corporation reserves the right to make improvements in design or changes in specification at any time without incurring any obligation to owners of equipment previously sold.

No agent or person has authority to alter, add to or waive the above warranties which are agreed to be in the only warranties, representations or promises, expressed or implied, as to the quality or performance of the products covered and which do not include any implied warranty of merchantability or fitness. In no event will Tiger be liable for incidental or consequential damages or injuries, including, but not limited to, loss of profits, rental or substitute equipment or other commercial loss.

### **THERE ARE NO WARRANTIES WHICH EXTEND BEYOND THOSE EXPRESSED HEREIN.**

It is the Purchasers obligation to sign the warranty registration form **AFTER** he / she has Read and Understands the Operation and Safety Instructions stated within this manual.

## **ONE LAST WORD**

This manual cannot possibly cover all of the potentially hazardous situations you will encounter. By being familiar with the safety rules, operating and maintenance instructions in this manual you can help prevent accidents. The objective of this manual is to help make you a better operator. Remember, **SAFETY IS YOU!**



1012

Your safety and the safety of those around you depends on **YOU**. Common sense should play a large role in the operation of this machine.

Since we at Tiger Corporation are constantly striving to improve our products, we reserve the right to change specifications or design at any time.

## TO THE OWNER / OPERATOR / DEALER



To keep your implement running efficiently and safely, read your manual thoroughly and follow these directions and the Safety Messages in this manual and on the machine. The table of contents clearly identifies each section where you can easily find the information you need.

The Occupational Safety and Health Act (OSHA 1928.51 subpart C) makes the following minimum requirements for tractor operators.

### **OWNER REQUIREMENTS:**

1. Provide a Roll-Over-Protective Structure that meets the requirements of this Standard; and
2. Provide Seatbelts that meet the requirements of this Standard and SAE J3C; and
3. Ensure that each employee uses such Seatbelt while the tractor is moving; and
4. Ensure that each employee tightens the Seatbelt sufficiently to confine the employee to the protected area provided by the ROPS.

### **OPERATOR REQUIREMENTS:**

1. Securely fasten seatbelt if the tractor has a ROPS.
2. Where possible, avoid operating the tractor near steep ditches, embankments, and holes.
3. Reduce speed when turning, crossing slopes, and on rough, slick, or muddy surfaces.
4. Stay off slopes too steep for safe operation.
5. Watch where you are going – especially at row ends, on roads, and around trees.
6. Do Not permit others to ride.
7. Operate the tractor smoothly – no jerky turns, starts, or stops.
8. Hitch only to the draw-bar and hitch points recommended by the tractor manufacturer.
9. When the tractor is stopped, set brakes securely and use park lock, if available





Printed in USA  
© Tiger Corporation