



TRIPLE FLAIL ASSEMBLIES

JD 54-5525
CAB

Current as of 10/29/2010



PARTS LISTING WITH
MOUNTING AND OPERATING
INSTRUCTIONS

06010004

Tiger Corporation
3301 N. Louise Ave.
Sioux Falls, SD 57107
1-800-843-6849
1-605-336-7900
www.tiger-mowers.com

06010004

TO THE OWNER / OPERATOR / DEALER

All implements with moving parts are potentially hazardous. There is no substitute for a cautious, safe-minded operator who recognizes the potential hazards and follows reasonable safety practices. The manufacturer has designed this implement to be used with all its safety equipment properly attached to minimize the chance of accidents.

BEFORE YOU START!! Read the safety messages on the implement and shown in this manual. Observe the rules of safety and use common sense!

READ AND UNDERSTAND THIS MANUAL! Non-English speaking operators will need to GET THE MANUAL TRANSLATED as needed!



DANGER

FAILING TO FOLLOW SAFETY MESSAGES AND OPERATING INSTRUCTIONS CAN CAUSE SERIOUS BODILY INJURY OR EVEN DEATH TO OPERATOR AND OTHERS IN THE AREA.



1. Study and understand Operator's Manuals, Safety Decals, and Instructional Decals for tractor and implement to prevent misuse, abuse, and accidents. Practice before operating in a confined area or near passersby.

● Learn how to stop engine suddenly in an emergency. Be alert for passersby and especially children

2. Allow no children on or near folding mower or tractor. Allow no riders on tractor or implement. Falling off may cause serious injury or death from being run over by tractor or mower or contact with rotating blades.

3. Operate only with tractor having Roll-Over Protective Structure (ROPS) and with seat belt securely fastened to prevent injury and possible death from falling off or tractor overturn.

● Personal Protective Equipment such as Hard Hat, Safety Glasses, Safety Shoes, & Ear Plugs are recommended.

4. Block up or support raised machine and all lifted components securely before putting hands or feet under or working underneath any lifted component to prevent crushing injury or death from sudden dropping or inadvertent operation of controls. Make certain area is clear before lowering or folding

5. Before transporting, put Lift Lever in detent or full-lift position. Install Transport Safety Devices securely on folding mowers. Put Booms securely in Transport Rest.

● Folding and Boom Mowers have raised center of gravity. Slow down when turning and on hillsides.

6. Make certain that SMV sign, warning lights, and reflectors are clearly visible. Follow local traffic codes.

7. Never operate with Cutting Head or Folding Section raised if passersby, bystanders, or traffic are in the area to reduce possibility of injury or death from objects thrown by Blades under Guards or mower structure.

8. Before dismounting, secure implement in transport position or lower to ground.

● Put tractor in park or set brake, disengage PTO, stop engine, remove key, and wait until noise of rotation has ceased to prevent crushing by entanglement in rotating parts which could cause injury or death.

● Never mount or dismount a moving vehicle. Crushing from rollover may cause serious injury or death.



02967827

Warranty Information: Read and understand the complete Warranty Statement found in this manual. Fill out the Warranty Registration form in full and return it within 90 days. Make certain the Serial Number of the machine is recorded on the Warranty Card, and form that you retain.

FORWARD

This manual contains information about many features of the Tiger mowing and roadside maintenance equipment. Some of these include: Safety precautions, Assembly instructions, Operations, Maintenance and Parts. This manual will also assist you in the proper break-in, daily care, and troubleshooting of your new mower.

We recommend that you read carefully the entire manual before operating the unit. Also, time spent in becoming fully acquainted with its performance features, adjustments, and maintenance schedules will be repaid in a long and satisfactory life of the equipment.

Troubleshooting - Please, before you call, help us to help you!

Please look at the equipment to observe what is happening, then:

- Classify the problem
 - Hydraulic, electrical or mechanical - Read the trouble shooting section
 - Tractor or Truck chassis - Contact vehicle dealer

- If unable to correct the problem yourself, contact your local Tiger Dealer after gathering:
 - Machine model _____
 - Serial number _____
 - Dealer name _____
 - Detailed information about the problem including results of troubleshooting

Attention Owner / Operator / Dealer : It is your obligation to read, and understand, the warranty information section located at the back of this manual denoting that the purchaser understands the safety issues relating to this machine and has received and will read a copy of this manual.

If at any time, you have a service problem with your Tiger mower, Contact your local dealer for service and parts needed.

MANUFACTURED BY:

Tiger Corporation

3301 N. Louise Ave.

Sioux Falls, SD 57107

1-800-843-6849

1-605-336-7900

www.tiger-mowers.com

DISTRIBUTED BY:

1-_____-_____-_____

1-_____-_____-_____

TABLE OF CONTENTS

SAFETY _____	1-1
Safety Information_____	1-2
ASSEMBLY / MOUNTING SECTION _____	2-1
OPERATION SECTION _____	3-1
MAINTENANCE SECTION _____	4-1
PARTS SECTION _____	5-1
Parts Ordering Guide_____	5-2
Parts Table of Contents_____	5-3
Common Parts Section _____	6-1
WARRANTY INFORMATION _____	7-1



1012

This symbol means:

CAUTION – YOUR SAFETY IS AT RISK!

When you see this symbol, read and follow the associated instructions carefully or personal injury or damage may result.

Tiger is a registered trademark.



SAFETY

SAFETY SECTION

SAFETY

General Safety Instructions and Practices

A safe and careful operator is the best operator. Safety is of primary importance to the manufacturer and should be to the owner / operator. Most accidents can be avoided by being aware of your equipment, your surroundings, and observing certain precautions. The first section of this manual includes a list of Safety Messages that, if followed, will help protect the operator and bystanders from injury or death. Read and understand these Safety Messages before assembling, operating or servicing this mower. This equipment should only be operated by those persons who have read the Manual, who are responsible and trained, and who know how to do so safely and responsibly.



1000

The Safety Alert Symbol combined with a Signal Word, as seen below, is used throughout this manual and on decals which are attached to the equipment. The Safety Alert Symbol means: **“ATTENTION! BECOME ALERT! YOUR SAFETY IS INVOLVED!”** The symbol and signal word are intended to warn the owner / operator of impending hazards and the degree of possible injury when operating this equipment.

Practice all usual and customary safe working precautions and above all -- remember safety is up to YOU! Only YOU can prevent serious injury or death from unsafe practices.

DANGER!



Indicates an imminently hazardous situation that, if not avoided, WILL result in DEATH OR VERY SERIOUS INJURY.

WARNING!



Indicates an imminently hazardous situation that, if not avoided, COULD result in DEATH OR SERIOUS INJURY.

CAUTION!



Indicates an imminently hazardous situation that, if not avoided, MAY result in MINOR INJURY.

IMPORTANT!

Identifies special instructions or procedures that, if not strictly observed, could result in damage to, or destruction of the machine, attachments or the environment.

NOTE: *Identifies points of particular interest for more efficient or convenient operation or repair.* (SG-1)

READ, UNDERSTAND, and FOLLOW the following Safety Messages. Serious injury or death may occur unless care is taken to follow the warnings and instructions stated in the Safety Messages. Always use good common sense to avoid hazards. (SG-2)

SAFETY INSTRUCTIONS



SAFETY

PELIGRO!



Si no lee Ingles, pida ayuda a alguien que si lo lea para que le traduzca las medidas de seguridad. (SG-3)



¡ LEA EL INSTRUCTIVO!

DANGER!



Never operate the Tractor or Implement until you have read and completely understand this Manual, the Tractor Operator's Manual, and each of the Safety Messages found in the Manual or on the Tractor and Implement. Learn how to stop the tractor engine suddenly in an emergency. Never allow inexperienced or untrained personnel to operate the Tractor and Implement without supervision. Make sure the operator has fully read and understands the manuals prior to operation. (SG-4)



WARNING!



Always maintain the safety decals in good readable condition. If the decals are missing, damaged, or unreadable, obtain and install replacement decals immediately. (SG-5)

WARNING!



Make certain that the "Slow Moving Vehicle" (SMV) sign is installed in such a way as to be clearly visible and legible. When transporting the Equipment use the Tractor flashing warning lights and follow all local traffic regulations. (SG-6)



WARNING!



Operate this Equipment only with a Tractor equipped with an approved roll-over-protective system (ROPS). Always wear seat belts. Serious injury or even death could result from falling off the tractor--particularly during a turnover when the operator could be pinned under the ROPS. (SG-7)



WARNING!



Do not modify or alter this Implement. Do not permit anyone to modify or alter this Implement, any of its components or any Implement function. (SG-8)

DANGER!



BEFORE leaving the tractor seat, always engage the brake and/or set the tractor transmission in parking gear, disengage the PTO, stop the engine, remove the key, and wait for all moving parts to stop. Place the tractor shift lever into a low range or parking gear to prevent the tractor from rolling. Never dismount a Tractor that is moving or while the engine is running. Operate the Tractor controls from the tractor seat only. (SG-9)

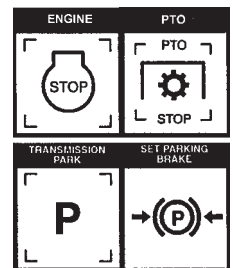

SAFETY

DANGER!



Never allow children or other persons to ride on the Tractor or Implement. Falling off can result in serious injury or death.

(SG-10)



DANGER!



Never allow children to operate or ride on the Tractor or Implement.

(SG-11)



WARNING!



Do not mount the tractor while the tractor is moving. Mount the tractor only when the tractor and all moving parts are completely stopped.

(SG-12)



DANGER!



Start tractor only when properly seated in the tractor seat. Starting a tractor in gear can result in injury or death. Read the tractor operators manual for proper starting instructions.

(SG-13)



DANGER!



Never work under the Implement, the framework, or any lifted component unless the Implement is securely supported or blocked up to prevent sudden or inadvertent falling which could cause serious injury or even death.

(SG-14)



DANGER!



Do not operate this Equipment with hydraulic oil leaking. Oil is expensive and its presence could present a hazard. Do not check for leaks with your hand! Use a piece of heavy paper or cardboard. High-pressure oil streams from breaks in the line could penetrate the skin and cause tissue damage including gangrene. If oil does penetrate the skin, have the injury treated immediately by a physician knowledgeable and skilled in this procedure.

(SG-15)



SAFETY

WARNING!



The operator and all support personnel should wear hard hats, safety shoes, safety glasses, and proper hearing protection at all times for protection from injury including injury from items thrown by the equipment. (SG-16)

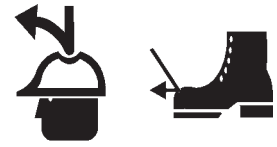

CAUTION!



PROLONGED EXPOSURE TO LOUD NOISE MAY CAUSE PERMANENT HEARING LOSS! Tractors with or without an Implement attached can often be noisy enough to cause permanent hearing loss. We recommend that you always wear hearing protection if the noise in the operator's position exceeds 80db. Noise over 85db over an extended period of time will cause severe hearing loss. Noise over 90db adjacent to the operator over an extended period of time will cause permanent or total hearing loss. *Note:* Hearing loss from loud noise [from tractors, chain saws, radios, and other such sources close to the ear] is cumulative over a lifetime without hope of natural recovery. (SG-17)



WARNING!



Transport only at safe speeds. Serious accidents and injuries can result from operating this equipment at unsafe speeds. Understand the Tractor and Implement and how it handles before transporting on streets and highways. Make sure the Tractor steering and brakes are in good condition and operate properly.

Before transporting the Tractor and Implement, determine the safe transport speeds for you and the equipment. Make sure you abide by the following rules:

1. Test the tractor at a slow speed and increase the speed slowly. Apply the brakes smoothly to determine the stopping characteristics of the Tractor and Implement. As you increase the speed of the Tractor the stopping distance increases. Determine the maximum safe transport speed for you and this equipment.
2. Test the equipment at a slow speed in turns. Increase the speed through the turn only after you determine that it is safe to operate at a higher speed. Use extreme care and reduce your speed when turning sharply to prevent the tractor and implement from turning over. Determine the maximum safe turning speed for you and this equipment before operating on roads or uneven ground.
3. Only transport the Tractor and Implement at the speeds that you have determined are safe and which allow you to properly control the equipment.

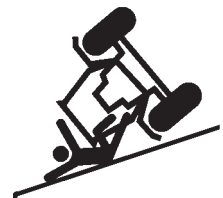

Be aware of the operating conditions. Do not operate the Tractor with weak or faulty brakes. When operating down a hill or on wet or rain slick roads, the braking distance increases: use extreme care and reduce your speed. When operating in traffic always use the Tractor's flashing warning lights and reduce your speed. Be aware of traffic around you and watch out for the other guy. (SG-19)

SAFETY

WARNING!



Never attempt to lubricate, adjust, or remove material from the Implement while it is in motion or while tractor engine is running. Make sure the tractor engine is **OFF** before working on the Implement.

(SG-20)

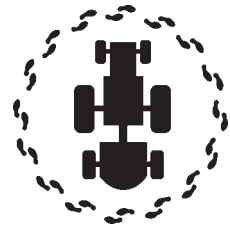

WARNING!



Periodically inspect all moving parts for wear and replace when necessary with authorized service parts. Look for loose fasteners, worn or broken parts, and leaky or loose fittings. Make sure all pins are properly secured. Serious injury may occur from not maintaining this machine in good working order. (SG-21)



WARNING!



Always read carefully and comply fully with the manufacturers instructions when handling oil, solvents, cleansers, and any other chemical agent. (SG-22)



DANGER!



Never run the tractor engine in a closed building or without adequate ventilation. The exhaust fumes can be hazardous to your health.

(SG-23)

DANGER!



KEEP AWAY FROM ROTATING ELEMENTS to prevent entanglement and possible serious injury or death.

(SG-24)



DANGER!



Never allow children to play on or around Tractor or Implement. Children can slip or fall off the Equipment and be injured or killed. Children can cause the Implement to shift or fall crushing themselves or others. (SG-25)

WARNING!



Do not exceed the rated PTO speed for the Implement. Excessive PTO speeds can cause Implement driveline or blade failures resulting in serious injury or death. (SG-26)

SAFETY

DANGER!



NEVER use drugs or alcohol immediately before or while operating the Tractor and Implement. Drugs and alcohol will affect an operator's alertness and coordination and therefore affect the operator's ability to operate the equipment safely. Before operating the Tractor or Implement, an operator on prescription or over-the-counter medication must consult a medical professional regarding any side effects of the medication that would hinder their ability to operate the Equipment safely. **NEVER** knowingly allow anyone to operate this equipment when their alertness or coordination is impaired. Serious injury or death to the operator or others could result if the operator is under the influence of drugs or alcohol. (SG-27)



DANGER!



Operate the Tractor and/or Implement controls only while properly seated in the Tractor seat with the seat belt securely fastened around you. Inadvertent movement of the Tractor or Implement may cause serious injury or death. (SG-29)

WARNING!



Mow only in conditions where you have clear visibility in daylight or with adequate artificial lighting. Never mow in darkness or foggy conditions where you cannot clearly see at least 100 yards in front and to the sides of the tractor and mower. Make sure that you can clearly see and identify passersby, steep slopes, ditches, drop-offs, overhead obstructions, power lines, debris and foreign objects. If you are unable to clearly see this type of items discontinue mowing. (SGM-1)

DANGER!



There are obvious and hidden potential hazards in the operation of this Mower. **REMEMBER!** This machine is often operated in heavy brush and in heavy weeds. The Blades of this Mower can throw objects if shields are not properly installed and maintained. Serious injury or even death may occur unless care is taken to insure the safety of the operator, bystanders, or passersby in the area. Do not operate this machine with anyone in the immediate area. Stop mowing if anyone is within 100 yards of mower. (SFL-1)



DANGER!



All Safety Shields, Guards and Safety devices including (but not limited to) - the Deflectors, Steel Guards, Gearbox Shields, PTO integral shields, and Retractable Door Shields should be used and maintained in good working condition. All safety devices should be inspected carefully at least daily for missing or broken components. Missing, broken, or worn items must be replaced at once to reduce the possibility of injury or death from thrown objects, entanglement, or blade contact. (SFL-5)

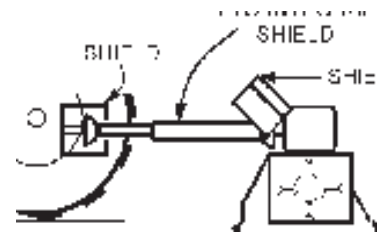

SAFETY

DANGER!



The rotating parts of this machine have been designed and tested for rugged use. However, the blades could fail upon impact with heavy, solid objects such as metal guard rails and concrete structures. Such impact could cause the broken objects to be thrown outward at very high velocities. To reduce the possibility of property damage, serious injury, or even death, never allow the cutting blades to contact such obstacles. (SGM-4)

WARNING!



Extreme care should be taken when operating near loose objects such as gravel, rocks, wire, and other debris. Inspect the area before mowing. Foreign objects should be removed from the site to prevent machine damage and/or bodily injury or even death. Any objects that cannot be removed must be clearly marked and carefully avoided by the operator. Stop mowing immediately if blades strike a foreign object. Repair all damage and make certain rotor or blade carrier is balanced before resuming mowing. (SGM-5)



WARNING!



Many varied objects, such as wire, cable, rope, or chains, can become entangled in the operating parts of the mower head. These items could then swing outside the housing at greater velocities than the blades. Such a situation is extremely hazardous and could result in serious injury or even death. Inspect the cutting area for such objects before mowing. Remove any like object from the site. Never allow the cutting blades to contact such items. (SGM-6)

WARNING!



Mow at the speed that you can safely operate and control the tractor and mower. Safe mowing speed depends on terrain condition and grass type, density, and height of cut. Normal ground speed range is from 0 to 5 mph. Use slow mowing speeds when operating on or near steep slopes, ditches, drop-offs, overhead obstructions, power lines, or when debris and foreign objects are to be avoided. (SGM-7)

WARNING!



Avoid mowing in reverse direction when possible. Check to make sure there are no persons behind the mower and use extreme care when mowing in reverse. Mow only at a slow ground speed where you can safely operate and control the tractor and mower. Never mow an area that you have not inspected and removed debris or foreign material. (SGM-8)

DANGER!



Replace bent or broken blade with new blades. NEVER ATTEMPT TO STRAIGHTEN OR WELD ON BLADES SINCE THIS WILL LIKELY CRACK OR OTHERWISE DAMAGE THE BLADE WITH SUBSEQUENT FAILURE AND POSSIBLE SERIOUS INJURY FROM THROWN BLADES. (SGM-10)

WARNING!



Do not mow with two machines in the same area except with Cab tractors with the windows closed. (SGM-11)

SAFETY

DANGER!



Flail Mowers are capable under adverse conditions of throwing objects for great distances (100 yards or more) and causing serious injury or death. Follow safety messages carefully.

STOP MOWING IF PASSERSBY ARE WITHIN 100 YARDS UNLESS:

- Front and Rear Deflectors are installed and in good, working condition;
- Mower Head is running close to and parallel to the ground without exposed Blades;
- Passersby are outside the existing thrown-object zone;
- All areas have been thoroughly inspected and all foreign material such as rocks, cans, glass, and general debris has been removed.

NOTE: Where there are grass and weeds high enough to hide debris that could be struck by the blades, the area should be: inspected and large debris removed, mowed at an intermediate height, inspected closely with any remaining debris being removed, and mowed again at desired final height. (SFL-6)



DANGER!



Do not put hands or feet under mower decks. Blade Contact can result in serious injury or even death. Stay away until all motion has stopped and the decks are securely blocked up. (SFL-2)



WARNING!



Each Rear Wheel must have a minimum of 1,000 pounds contact with the surface to prevent lateral instability and possible tip-over which could result in serious bodily injury or even death. Widen the wheel tread and add weights if needed. Refer to the mounting instructions or call Customer Service if you need assistance with Counterweight Procedure. (SFL-3)



WARNING!



Do not operate Mower if excessive vibration exists. Shut down PTO and the Tractor engine. Inspect the Mower to determine the source of the vibration. If Mower blades are missing or damaged replace them immediately. Do not operate the mower until the blades have been replaced and the Mower operates smoothly. Operating the Mower with excessive vibration can result in component failure and broken objects to be thrown outward at very high velocities. To reduce the possibility of property damage, serious injury, or even death, never allow the Mower to be operated with blades missing. (SFL-4)

WARNING!



Be particularly careful when transporting the Implement with the Tractor. Turn curves or go up hills only at a low speed and using a gradual steering angle. Rear mounted implements move the center of gravity to the rear and remove weight from the front wheels. Make certain, by adding front ballast, that at least 20% of the tractor's weight is on the front wheels to prevent rearing up, loss of steering control or Tractor tip-over. Slow down on rough or uneven surfaces to prevent loss of steering control which could result in property damage or possible injury. Do not transport unless 3-Point lift lever is fully raised and in the latched transport position. Dropping implement in transport can cause serious damage to the tractor and/or Implement and possibly cause the operator or others to be injured or killed. (S3PT-2)

SAFETY

DANGER!



Always disconnect the main PTO Driveline from the Tractor before performing service on the Mower. Never work on the Mower with the tractor PTO driveline connected and running. Blades or Drivelines could turn without warning and cause immediate entanglement, injury or death.

(SRM-3)

WARNING!



Do not let the Blades turn when the Mower Deck is raised for any reason, including clearance or for turning. Raising the Mower deck exposes the Cutting Blades which creates a potentially serious hazard and could cause serious injury or even death from objects thrown from the Blades.

(SRM-7)



WARNING!



Never leave Tractor and Implement unattended while the implement is in the lifted position. Accidental operation of lifting lever or a hydraulic failure may cause sudden drop of unit with injury or death by crushing. To properly park the implement when disconnecting it from the tractor, lower the stand and put the retaining pin securely in place, or put a secure support under the A-Frame. Lower the implement carefully to the ground. Do not put hands or feet under lifted components.

(SPT-1)

DANGER!



Make sure the PTO shield, integral driveline shields, and input shields are installed when using PTO-driven equipment. Always replace any shield if it is damaged or missing.

(S3PT-8)



WARNING!



Relieve hydraulic pressure prior to doing any maintenance or repair work on the Implement. Place the Implement on the ground or securely blocked up, disengage the PTO, and turn off the tractor engine. Push and pull the Remote Cylinder lever in and out several times prior to starting any maintenance or repair work.

(S3PT-9)



WARNING!



Use extreme care when lowering or unfolding the implement's wings. Make sure no bystanders are close by or underneath the wings. Allow ample clearance around the implement when folding or unfolding the wings. Use extreme caution around buildings or overhead power lines.

(S3PT-5)

DANGER!



When the Wings are folded for transport, the center of gravity is raised and the possibility of overturn is increased. Drive slowly and use extreme caution when turning on hillsides. Overturning the Implement could cause the Implement to overturn the Tractor and vice versa resulting in serious injury or even death. Never fold wings on a hillside...the Implement may overturn.

(STI-2)

DANGER!



DO NOT allow any person under a folded wing unless wing is securely locked up or supported. **DO NOT** approach the Implement unless the Tractor is turned off and all motion has ceased. Never work under the frame work, or any lifted component unless the implement is securely supported or blocked up. A sudden or inadvertent fall by any of these components could cause serious injury or even death.

(STI-3)



SAFETY

DANGER!



The flail cutter shaft is designed for standard rotation (same rotation as the tractor wheels during forward travel). **Never operate the cutter shaft in the reverse rotation.** Operating this mower in reverse rotation may cause objects to be thrown out the front of the mower head.



WARNING!



The rotating parts of this machine continue to rotate even after the PTO has been turned off. The operator should remain in his seat for 60 seconds after the brake has been set, the PTO disengaged, the tractor turned off, and all evidence of rotation has ceased.

(3PT-10)

“Wait a minute...Save a life!”

WARNING!



Engine Exhaust, some of its constituents, and certain components contain or emit chemicals known to the state of California to cause cancer and birth or other reproductive harm.

WARNING!



Battery posts, terminals and related accessories contain lead and lead compounds, chemicals known to the state of California to cause cancer and birth or other reproductive harm. **Wash hands after handling!**

Tiger mowers use balanced and matched system components for blade carriers, blades, cutter-shafts, knives, knife hangers, rollers, drive-train components and bearings. These parts are made and tested to Tiger specifications. Non-genuine “will fit” parts do not consistently meet these specifications. The use of “will fit” parts MAY reduce mower performance, void mower warranties and present a safety hazard. Use genuine Tiger mower parts for economy and safety.

SEE YOUR  DEALER

In addition to the design and configuration of this Implement, including Safety Signs and Safety Equipment, hazard control and accident prevention are dependent upon the awareness, concern, prudence, and proper training of personnel involved in the operation, transport, maintenance, and storage of the machine. Refer also to Safety Messages and operation instruction in each of the appropriate sections of the Tractor and Equipment Manuals. Pay close attention to the Safety Signs affixed to the Tractor and Equipment. (SG-18)

SAFETY

PART NO.
LOCATION

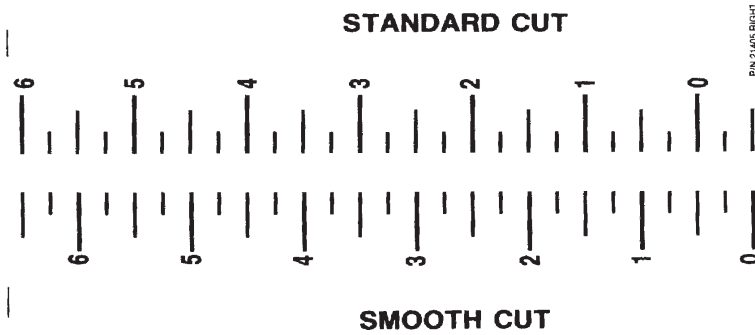

21405
MOWER DECK

**DO NOT LUBRICATE WITH AUTOMATIC
GREASE GUN. GREASE WITH HAND
GREASE GUN ONLY.**

P/N22839

22839
MOWER DECK



22840
INSIDE OF CAB

NO STEP

22865
MOWER DECK

SAFETY

WARNING

INSPECT REAR FLAP FREQUENTLY TO BE SURE IT IS IN SAFE WORKING CONDITION. DO NOT OPERATE MOWER WITH FLAP REMOVED OR WORN.

24028





PART NO.
LOCATION

24028
MOWER DECK





10" x 5.5" 31522
MOWER DECK
18" x 10" 31523
HYDRAULIC TANK

MOWING SAFETY TIPS

-  Read & understand the Operators Manual.
-  Wear Your Seat Belt.
-  Keep all shields and guards in place.
-  Make sure equipment is in proper working condition.



-  Never attempt to get off or on a moving tractor.

-  Never allow riders on tractor or equipment.
-  Only start the tractor from the seat with the key.

-  Always inspect the area before mowing. Remove all foreign debris.

-  Always keep bystanders and coworkers a minimum of 300 feet away.

-  Never allow the mower blades to contact solid objects or foreign material.

-  Never approach rotating elements.
-  Disengage the PTO, place transmission in "Park", set parking brake, shut off engine, and remove key and wait until all rotating motion has stopped before leaving seat.

Tiger

33743

33743
INSIDE OF CAB



42360

42350
MOWER DECK

SAFETY

PART NO.
LOCATION



42399
MOWER DECK



42400
MOWER DECK



6T3217
MOWER DECK



6T3219
INSIDE OF CAB

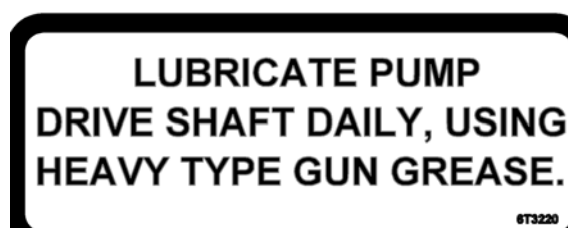

6T3220
FRONT PUMP MOUNT

SAFETY

NOTICE:
Engine will not
start when mower
is engaged.

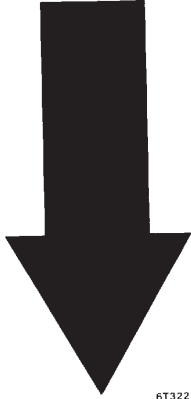

6T3222

PART NO.
LOCATION

6T3222
INSIDE OF CAB

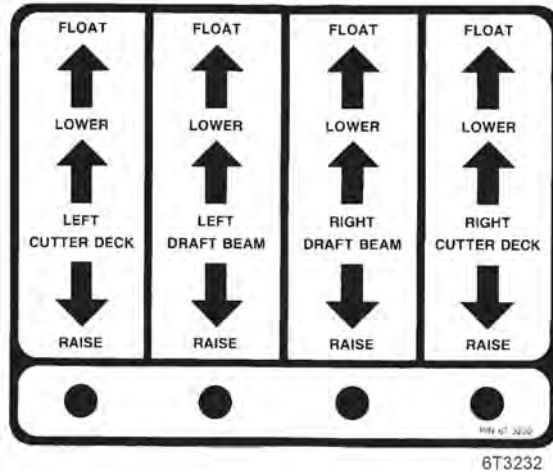

6T3232
INSIDE OF CAB



6T3224
MOWER DECK

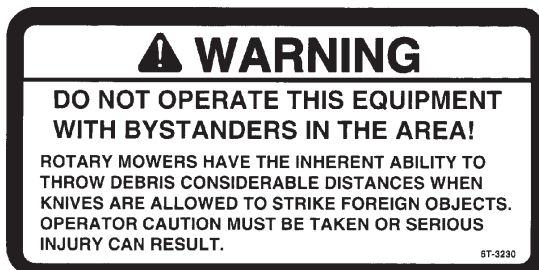

6T3230
INSIDE OF CAB

SAFETY

PART NO.
LOCATION



6T3233
HYDRAULIC TANK



6T3234
INSIDE OF CAB



6T3236
MOWER DECK
HYDRAULIC TANK



6T3242
INSIDE OF CAB

6T3242

SAFETY



Tiger Corporation

800-843-6849

www.tiger-mowers.com

Description	Application	General Specification	Recommended Lubricant
Tractor Hydraulics	Reservoir	JD-20C	Mobilfluid® 424
Mower Hydraulics Cold Temperatures 0°F Start-up Normal Temperatures 10°F Start-up Normal Temperatures 15°F Start-up High Operating Temperatures Above 90°F Ambient	Reservoir	ISO 46 Anti-Wear/ Low Temp JD-20C ISO 46 Anti-Wear ISO 100 Anti-Wear	Mobil DTE® 15M Mobilfluid® 424 Mobil DTE® 25 Mobil DTE® 18M
Flail Rear Gearbox	Reservoir	PAO Synthetic Extreme Pressure Gear Lube	Mobilube SHC® 75W-90, Mobil 1 Synthetic Gear Lubricant
Cutter Shaft and Ground Roller Shaft (Flail)	Grease Gun	Lithium Complex, NLGI 2 ISO 320	Mobilgrease® CM-S
Drive Shaft Coupler (Rotary and Flail)	Grease Gun	Lithium Complex, NLGI 2 ISO 320	Mobilgrease® CM-S
Boom Swivel, Boom Cylinder Pivots (Rotary and Flail Boom Type)	Grease Gun	Lithium Complex, NLGI 2 ISO 320	Mobilgrease® CM-S
Deck Boom Pivot & Deck Stop Adjustment (Rotary and Flail)	Grease Gun	Lithium Complex, NLGI 2 ISO 320	Mobilgrease® CM-S
Deck Spindle (Rotary)	Grease Gun	Tiger Spindle Lubricant	Mobilith SHC 220

For Mobil product information, availability, or technical information, call 1-800-662-4525.

Tiger PN 34852

34852

HYDRAULIC TANK

DANGER		PELIGRO
THROWN OBJECT HAZARD		RIESGO DE OBJETO LANZADO
Do not operate mower when cutter shaft is in reverse rotation unless: <ul style="list-style-type: none"> Reverse Rotation Front Guard is in place, and Guard is in good condition 		No funcione el cortacésped cuando el eje de cortador esta en rotación inverso al menos que: <ul style="list-style-type: none"> El Guardia Delantero de Rotación Inversa esta en su lugar y El guardia esta en buenas condiciones
 Reverse Rotation Front Guard	06550054	 Guardia Delantero De Rotación Inverso

D538
ON MOWER HEAD

SAFETY

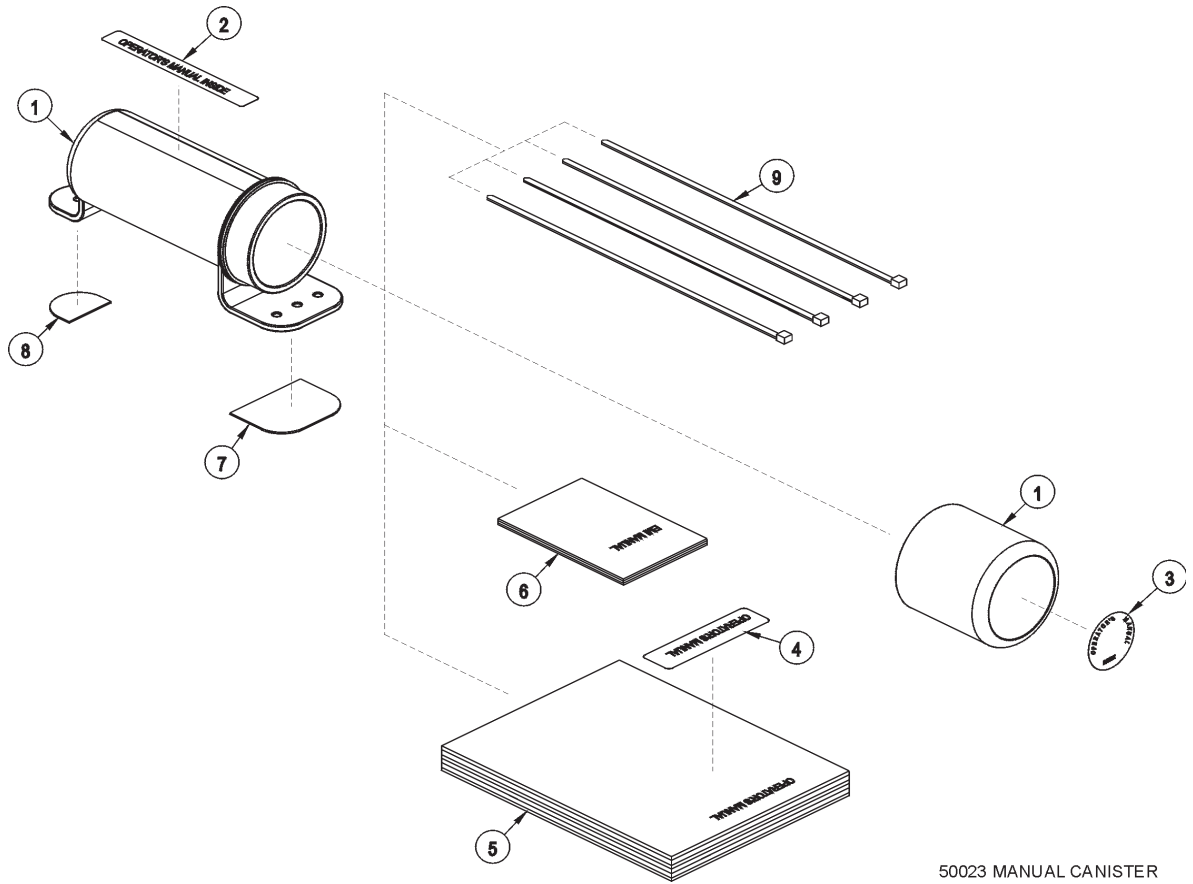

50023 MANUAL CANISTER

ITEM	PART NO.	QTY.	DESCRIPTION
	50023	AVAIL	MANUAL CANISTER COMPLETE
1	00776031	1	ROUND MANUAL CANISTER
	33997	1	DECAL, SHEET, MANUAL CANISTER
2		*	DECAL
3		*	DECAL
4		*	DECAL
5	*	AVAIL	SPECIFIC PRODUCT MANUAL
6	33753	1	E M I SAFETY MANUAL
7	34296	1	FRONT ADHESIVE PAD
8	34297	1	REAR ADHESIVE PAD
9	6T1823	4	ZIP TIE 14" LONG

NOTE:

The manual canister can be bolted, zip tied or adhered to a variety of surfaces. Locate a protected area within the view of the operator. Then select an installation method and attach the canister. **CAUTION - AVOID DRILLING HOLES INTO UNKNOWN AREAS**, wires and other parts may be located behind these areas. When adhering the canister to a surface, thoroughly clean that surface before installing the canister.

SAFETY

FEDERAL LAWS AND REGULATIONS

This section is intended to explain in broad terms the concept and effect of federal laws and regulations concerning employer and employee equipment operators. This section is not intended as a legal interpretation of the law and should not be considered as such.

Employer-Employee Operator Regulations

U.S. Public Law 91-596 (The Williams-Steiger Occupational and Health Act of 1970) OSHA

This Act Seeks:

“...to assure so far as possible every working man and woman in the nation safe and healthful working conditions and to preserve our human resources...”

DUTIES

Sec. 5 (a) Each employer-

(1) shall furnish to each of his employees employment and a place of employment which are free from recognized hazards that are causing or are likely to cause death or serious physical harm to his employees;

(2) shall comply with occupational safety and health standards promulgated under this Act.

(b) Each employee shall comply with occupational safety and health standards and all rules, regulations and orders issued pursuant to this Act which are applicable to his own actions and conduct.

OSHA Regulations

OSHA regulations state in part: “At the time of initial assignment and at least annually thereafter, the employer shall instruct every employee in the safe operation and servicing of all equipment with which the employee is, or will be involved.”

Employer Responsibilities:

To ensure employee safety during Tractor and Implement operation, it is the employer’s responsibility to:

1. Train the employee in the proper and safe operation of the Tractor and Implement.
2. Require that the employee read and fully understand the Tractor and Implement Operator’s manual.
3. Permit only qualified and properly trained employees to operate the Tractor and Implement.
4. Maintain the Tractor and Implement in a safe operational condition and maintain all shields and guards on the equipment.
5. Ensure the Tractor is equipped with a functional ROPS and seat belt and require that the employee operator securely fasten the safety belt and operate with the ROPS in the raised position at all times.
6. Forbid the employee operator to carry additional riders on the Tractor or Implement.
7. Provide the required tools to maintain the Tractor and Implement in a good safe working condition and provide the necessary support devices to secure the equipment safely while performing repairs and service.

Child Labor Under 16 Years of Age

Some regulations specify that no one under the age of 16 may operate power machinery. It is your responsibility to know what these regulations are in your own area or situation. (Refer to U.S. Dept. of Labor, Employment Standard Administration, Wage & Home Division, Child Labor Bulletin #102.)

SAFETY

ASSEMBLY SECTION

ASSEMBLY

Before attempting to mount or service your Tiger mower, it is important to read and understand all of the information in the Safety section of this manual.

Check complete shipment list against the packing list to make sure there are no shortages. Make certain the tractor model is the appropriate one for the mower received!

CAUTION!



Use a floor jack, hoist or fork lift to lift or raise heavy parts whenever possible whether mentioned or not.

Read and understand the entire assembly section instructions before attempting to mount your Tiger mower. Refer to the parts section of this manual for detailed illustrations to locate all parts.

TRACTOR PREPARATION

- A: Remove right and left hand steps.
- B: Disconnect cables from both batteries, (remove batteries and the battery box from cab units only.)
- C: Remove engine side panels, or raise hood to access front pulley.
- D: Remove plugs from tractor casting where main frame and pump mount will be attached.
- E: Raise the tractor onto jack-stands and remove the right and left rear wheels.

CRANKSHAFT ADAPTER

The 5525's crankshaft is located in a position that is difficult to reach. There are tools to aide in the connection of the crankshaft adapter. If necessary remove the four cap-screws from the crankshaft pulley. Then install the crankshaft adapter and spacer to the pulley with cap-screws and lock-washers as shown in the parts section

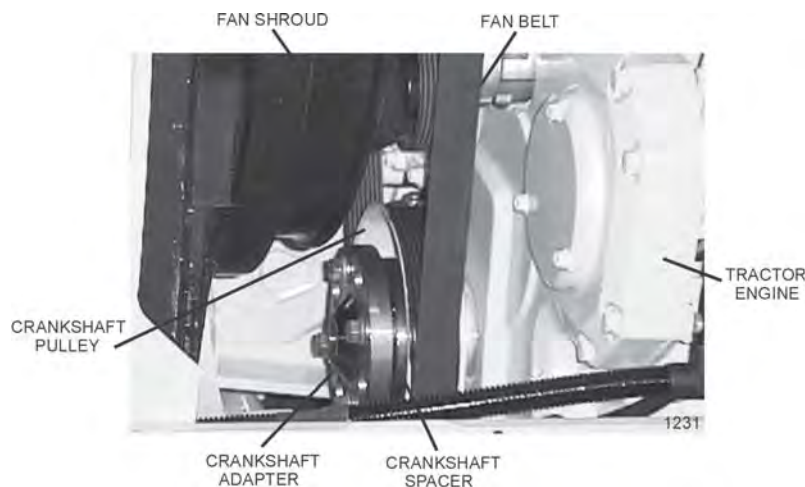

ASSEMBLY

DRIVESHAFT ACCESS

To access the driveshaft of the JD-5525, a hole will need to be cut in the front of the tractor frame. Find the tapped marking on the front end of the tractor (shown below.) Using a 1-1/2" hole saw, cut a hole for the driveshaft. Once the hole is cut you will be able to look through the hole and see the driveshaft cover.

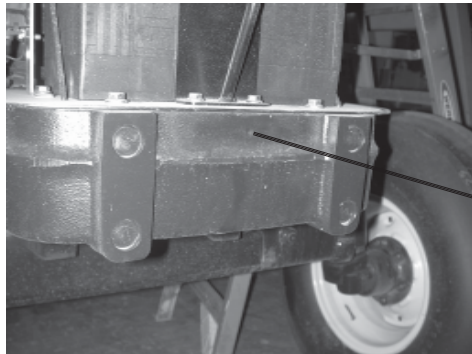

PRE-TAPPED MARKING

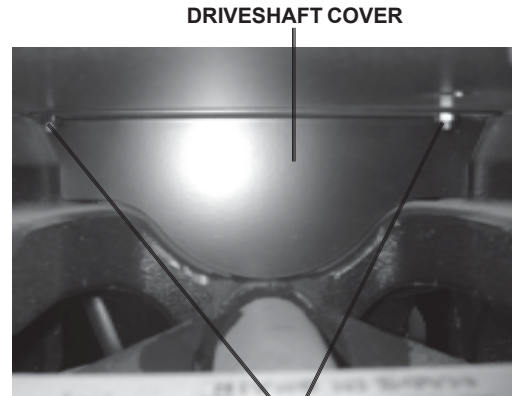

DRIVESHAFT COVER

HARDWARE TO BE REMOVED

The driveshaft cover is held on by two bolts. To remove these bolts take off the panel covering the fan. Then you will have access to the bolts on the driveshaft cover.

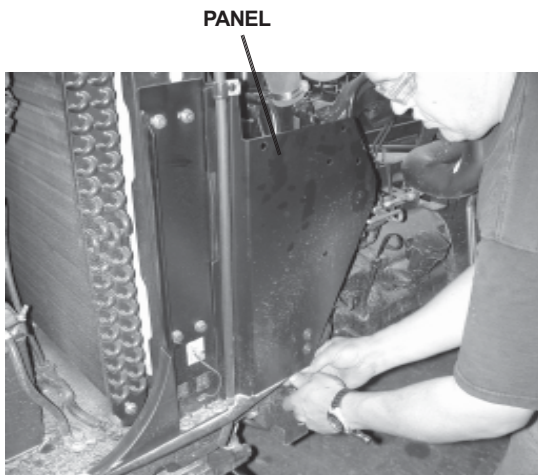

PANEL

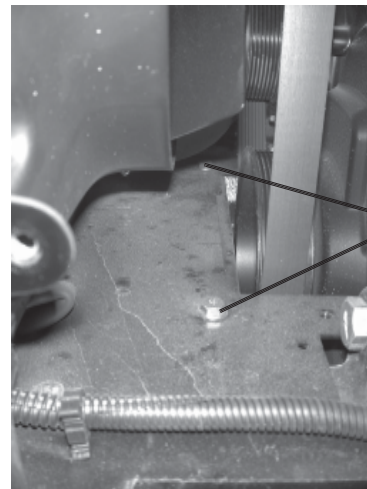

BOLTS TO BE REMOVED

ADJUSTING REAR WHEELS

Raise rear of tractor onto jack-stands and adjust tires / rims all the way out. **Follow the instructions in the tractor owners manual for adjusting tires and rims.** NOTE: This may require switching the wheels to opposite sides of tractor. Do not reinstall wheels onto tractor until valve has been mounted (cab), and all hoses have been installed

ASSEMBLY

CABLE CONTROL LEVER STAND

On the corner cab post, mark a point at 1-3/8" from the windshield and 22 1/2" from the floor; then cut a 3/4" diameter hole through the outer plastic shell. This will expose a threaded steel boss to attach the control box support bracket.

The rear corner of the cable control stand is placed approximately 5 3/4" from the edge of the mat. The front edge of the stand is up against the corner cab post and the door sill lip of the mat. Before you mark or drill any holes, check for support plates or wires under the mat & the cab floor. **NOTE:** Cutting into plates or wires makes more work for everyone and could be dangerous. When you know where the wires/plates lie, mark one of the mounting holes. Drill a 3/8" hole through the mat and through the floor of the cab. Next, lift the mat up and mark the other two holes on the cab floor. Drill the holes through the floor. Mark the mat and drill the other two 3/8" holes. Use a 1" hole saw and cut a 1" hole through the mat over each 3/8" hole. Secure the stand to the floor with the spacers, capscrews and nylock nuts provided.

STAND PLACEMENT



UNDER FLOOR OF CAB

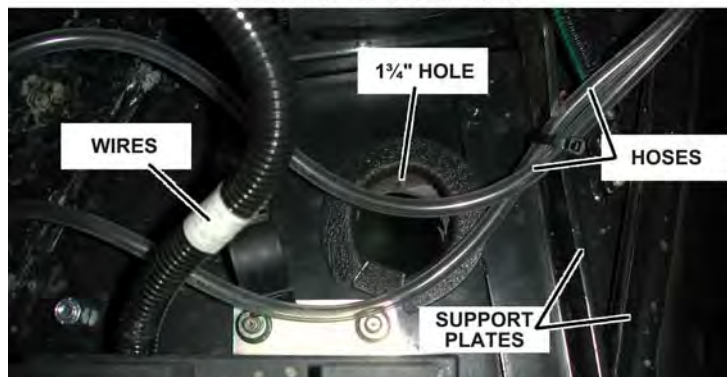

Cut a 1 3/4" hole in the floor to route the cables and wires through. It needs to have a 1/4" clearance for the trim lock. Before you mark or drill any holes, check for support plates or wires under the cab floor.

NOTE: Cutting into plates or wires makes more work for everyone and could be dangerous. Look under the floor for cables and plates that you need to avoid. The hole should be approximately 4 1/2" from the door sill and 4 3/4" from the lip of the mat under the console. Install the trim lock around the metal edges of the hole, then route the control cables and wires through the hole.



Next, wrap the cables with the 6" split hose at the point they pass through the hole, and secure the zip-tyes. Apply RTV sealer in and around individual cables and split hose, inside and outside of the cab for a water tight seal. Install upper support bracket from cab post to the control lever stand.

ASSEMBLY

CABLE CONTROL LEVER STAND continued

CUT CROSS HAIR PATTERN IN RUBBER BOOT FOR VALVE WIRES TO PASS THROUGH CAB WALL

CAB WINDOW

VALVE WIRES INSIDE OF WIRE WRAP



1226

WINDOW ROUTING

SWITCH BOX WIRING

The floor covering will need to be removed to route the wires to the front console panel. Refer to the parts section for wiring diagram to hook up the switch box. Cover the four wires from the switch box with plastic wire wrap provided. Route the wires from the switch box down to the floor and under the floor matt to the front console panel. From there, run the wires with the existing wires that go to the front console panel. Remove the console panel under the steering wheel to access wires. Locate the brown colored wire. **Using a test light or meter to verify** this wire is the neutral safety wire. Cut the brown wire and connect the green wires from the switch box as shown in the wiring diagram.

To run the white wire to the solenoid valve, you will need to drill a hole in the front edge of the cab floor to the right of the front console. Insert a rubber grommet into the hole to protect the wire, and route the wire out of the cab.

The red wire is to be hooked to the tractor ignition switch or an available slot in the fuse box. **NOTE: Be certain that the power taken for the switch box is "HOT" only when the tractor ignition is "ON". Also double check that the line is fused.**

The travel lock red wire from the switch box should also be covered with wire wrap and should run with the white wire through the grommet. This wire will be connected to the electronic travel lock located on the main boom cylinder.

The wires from the switch box are longer than needed and should carefully cut and spliced as required. Zip ties should be used to secure the wires to the tractor framework.

ASSEMBLY

VALVE MOUNTING BRACKET (CAB UNITS)

Attach the rear valve mounting bracket to the fender of the tractor by removing the two rear bolts on diesel tank and the two rear bolts of the tank on the opposite fender. Use the hardware noted in the parts section to attach the rear valve mount to the tractor.

CHECK THE PARTS SECTION FOR PLACEMENT OF HARDWARE.

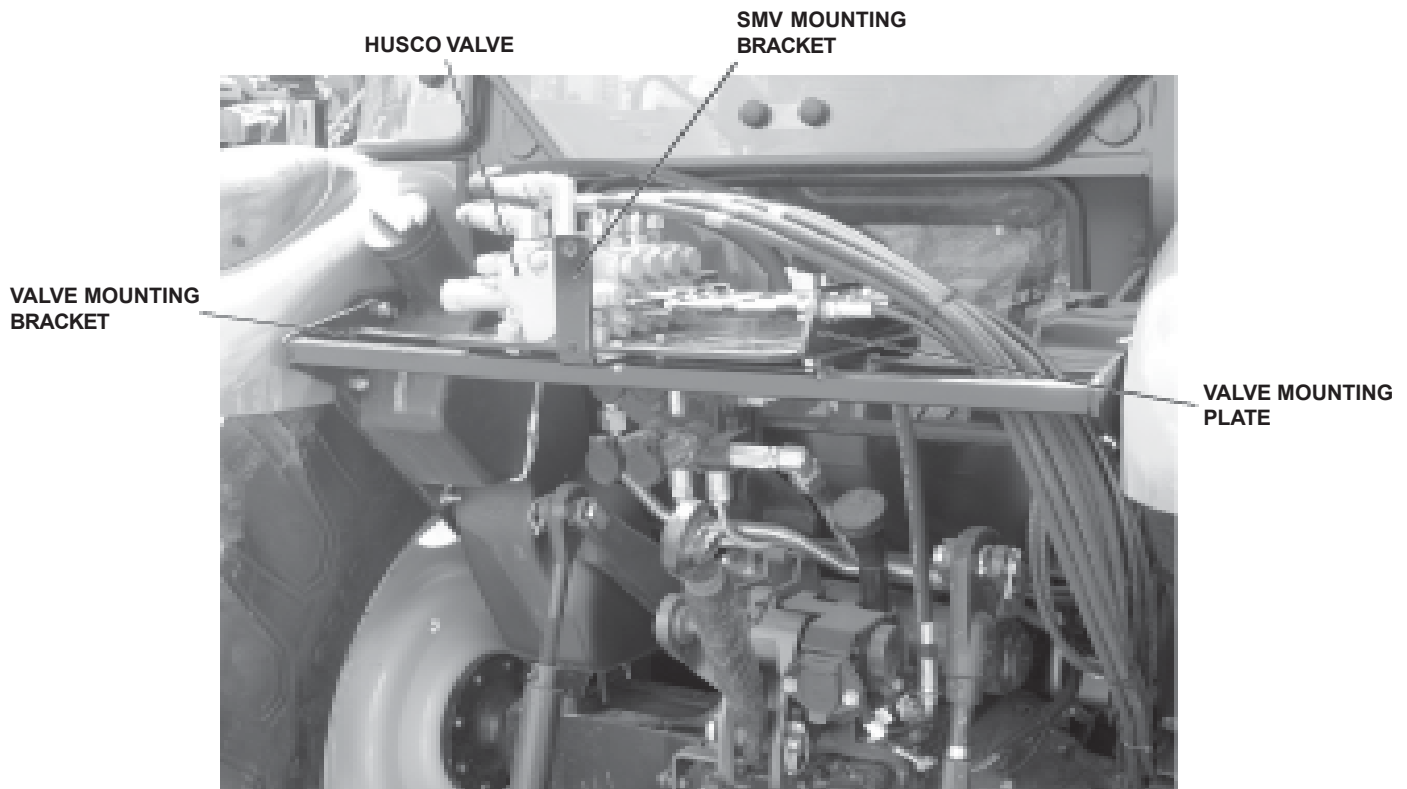

VALVE MOUNTING PLATE (CAB UNITS)

Attach the valve mounting plate to the mounting bracket as shown in the parts section. Align the holes in the plate to the holes on the bracket. Use the hardware shown in the parts section to attach the plate to the valve mounting bracket.

VALVE MOUNTING (CAB UNITS)

Attach the valve to the valve mounting plate as shown in the parts section. Align the holes on the valve assembly to the holes on the plate. Please note the placement of the valve and the hardware shown in the parts section. **Exercise caution when installing the valve, as it is extremely heavy.**

ASSEMBLY

TRIPLE FLAIL HYDRAULIC DIAGRAM

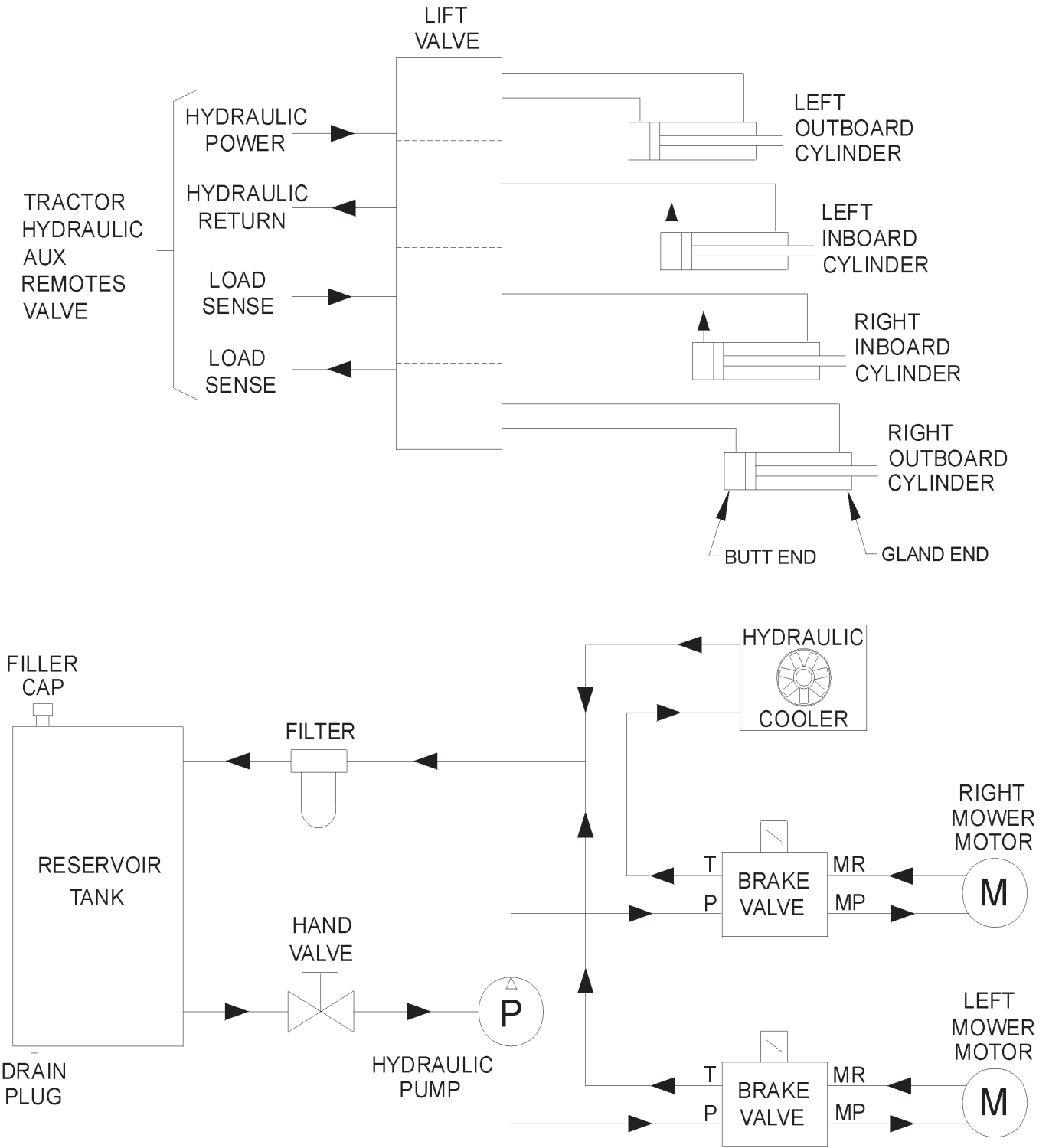

1323 TRIPLE FLAIL HYD DIAGRAM

ASSEMBLY

PRESSURE LINE INSTALLATION (CAB UNITS)

The hydraulic pressure line will be plumbed into the tractors power beyond port. Locate the power beyond port on the upper right side of the tractor rear remotes, remove the plug (refer to the illustration below and the Parts Section). After the plug is removed, connect the adapter and route the hose from the adapter to the lift valve, as shown in the parts section.

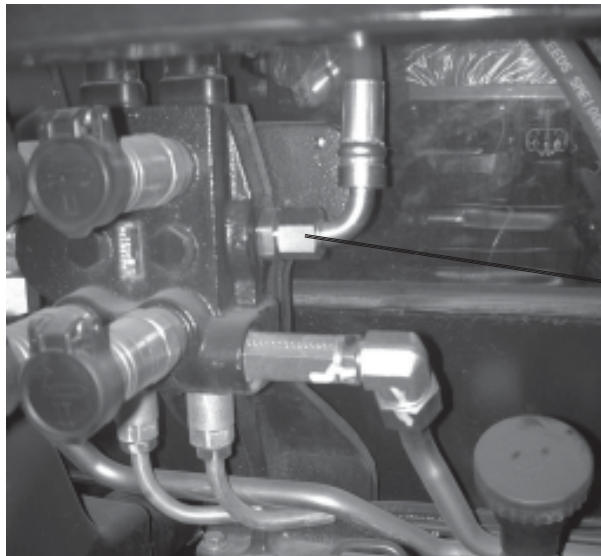

Power Beyond Port

RETURN LINE INSTALLATION (CAB UNITS)

The return line will be plumbed into the tank port at the base of the filler neck, located below and to the right of the power beyond port. Locate the tank port and remove the plug (refer to the illustration below and the Parts Section). After the plug is removed, connect the two adapters to the tractor tank port. Then connect a hose from the outer adapter to the Tiger lift valve return port, as shown in the parts section.

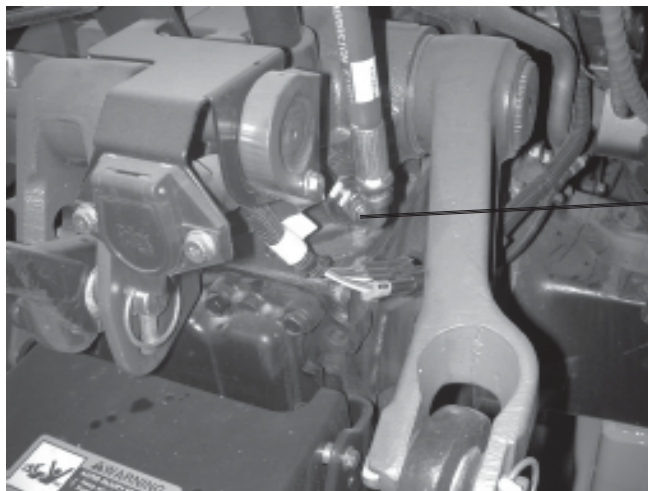

Tank Port - at the base of the filler neck

ASSEMBLY

INSTALLING O-RING FITTINGS

Installing straight, 45 degree and 90 degree O-ring fittings requires that the O-ring, washer and nut (A) be up against the swivel body (B). Insert the swivel and turn in until the swivel is pointed in the right direction and O-ring contact is made. Hold swivel in set direction with a wrench and turn the O-ring nut away from the swivel body and carefully tight

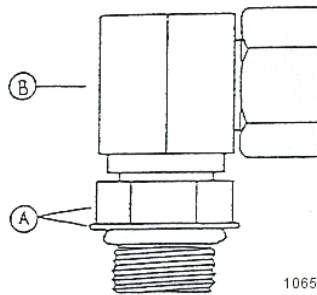

INSTALLING NATIONAL PIPE FITTINGS

Whenever installing a pipe fitting, wrap the threads clockwise (looking at the end) with teflon tape. In this way, the tape will be tightened when installed. NOTE: It is not necessary to tape O-ring fittings, or those installed in swivels.

MAIN FRAME MOUNTING

Raise front of tractor as needed and slide the main frame under tractor from right hand side. With an overhead hoist and / or jack-stands, raise the frame up to the correctly matching mounting holes. Install cap-screws and all other hardware as shown in main frame parts section. Remove the cap-screws one at a time and apply a thread locking agent, then reinsert the cap-screws and tighten / torque to values noted in the torque chart located in the maintenance section of this manual.

ASSEMBLY

HYDRAULIC TANK INSTALLATION

Install all fittings and tubes into tank and tank filter as shown in parts section illustration. Insert tank sight glass into front side of the tank. Install the temperature sensor or pipe plug into the side of the tank.

Place the tank in the mounting bracket on the main frame with fittings toward tractor and filter toward the cab.

Secure the tank in the mounting bracket with the tank strap and nylock nuts.

Install the filter gauge into the filter housing so that it points to the rear of the tractor and is clearly visible to the operator.

Locate the tank breather and reducer bushing (bushing may be already installed in the tank along with many of the for-mentioned parts). These will be installed after tank is filled.

FRONT PUMP MOUNTING

Install the pump mounting bracket on the front of the tractor with cap-screws and lock-washers as shown in the parts section illustration. DO NOT tighten fasteners at this time.

Thread the pump drive shaft into the crankshaft adapter.

Slide the splined drive shaft coupler onto the pump drive shaft. Install the pump onto the mounting bracket. NOTE: the pump is offset to one direction, the pump should be installed with the offset side on top. Install hardware for securing pump to the pump mount, DO NOT tighten.

Install pump and align so that splined coupling can be moved (FREE PLAY) back and forth by hand. Rotate coupler and check free play every 1/4 turn. Tighten pump mounting bolts in succession rechecking for spline coupling free play. Remove the pump mounting bracket bolts one at a time and apply a thread locking agent. Tighten these bolts in succession, again checking for free play in the drive shaft. After all bolts are torqued, the end play on the drive shaft should be 1/16" to 1/8", and coupler should move freely with hand pressure. If end play is less than 1/16", grind the end of the shaft to achieve the proper end play. If there is more than 1/4" of end play, return the shaft with specifications for a longer shaft.

CAUTION: DO NOT START THE TRACTOR UNTIL ALL HOSES ARE ATTACHED, TANK IS FILLED WITH PROPER OIL AND BALL VALVES ARE OPEN! STARTING AT THIS TIME WILL CAUSE SERIOUS DAMAGE TO THE PUMP.

GENERAL HOSE INSTALLATION

Refer to the parts section for detailed information about hoses and fittings for this application.

When mounting the suction hose between the pump and the tank, the stainless steel bands that are provided must be used. CAUTION: DO NOT use regular hose clamps for this purpose.

For protection of hoses in contact with metal edges, wrap hoses with spit hose sections and fasten with hose clamps or zip ties as needed.

ASSEMBLY

HOSE COVERING

Secure hoses together with zip ties wherever loose. Wrap the hoses between the main boom and secondary boom with the yellow hose cover, secure with black string provided. Where hoses may contact the frame or other edges, wrap with split hose and secure with hose clamps or zip ties. On non cab units the pressure and return hoses from the control valve will also need to be routed inside the protective clear hose wrap. Cover the valve, valve fittings with the yellow hose cover and secure with black string provided.

MOTOR SOLENOID VALVE MOUNTING

Install a motor solenoid valve to the bracket on main frame with the capscrews, star lockwasher flatwasher, lockwashers and hex nuts as shown in the parts section. Be sure that the pump and tank oil ports are pointing forward. Be sure that the star and regular lockwashers are not on the same capscrew. Ground one of the red solenoid wires to the mounting bolts with the star lockwasher at this time.

FILLING HYDRAULIC RESERVOIR

Refer to the maintenance section for filling specifications and hydraulic oil requirements.

NOTE: Starting or running your Tiger mower before filling reservoir will cause serious damage to hydraulic pump.

TEMPERATURE GAUGE MOUNTING

(OPTIONAL)

Mount the temperature gauge where it is clearly visible to the operator. Attach the green (-) wire from the negative post on the gauge to a grounded bolt on the tractor frame. Remove paint if needed to make a good ground.

Remove the pipe plug from the side of the hydraulic reservoir, and install the temperature sensor using thread sealing tape. Run the white wire from the (S) sensor post of the gauge to the temperature sensor on the hydraulic reservoir tank.

ASSEMBLY

COMBO LIFT DRAFT BEAM INSTALLATION

Install ½" O-ring breather into butt port of inboard cylinder. Install fittings in the rod end of the cylinder according to the diagram in the commons section. These fittings should be positioned to face the butt end of the cylinder.

Next turn the clevis onto the rod of the cylinder until it is tight against the shoulder and lock into place with locking bolt on clevis.

The inboard cylinder can now be installed into the main frame mast with the pin, flat-washer and R-clip as shown below. Use teflon tape on all fitting and hose connections.

Install all fittings in the outboard cylinder and adjust to point towards the butt end of the cylinder. Attach the hoses as specified in the parts book. Slide the cylinder into the draft beam from the outside of the draft beam and attach cylinder to the draft beam with clevis pin and rollpins.

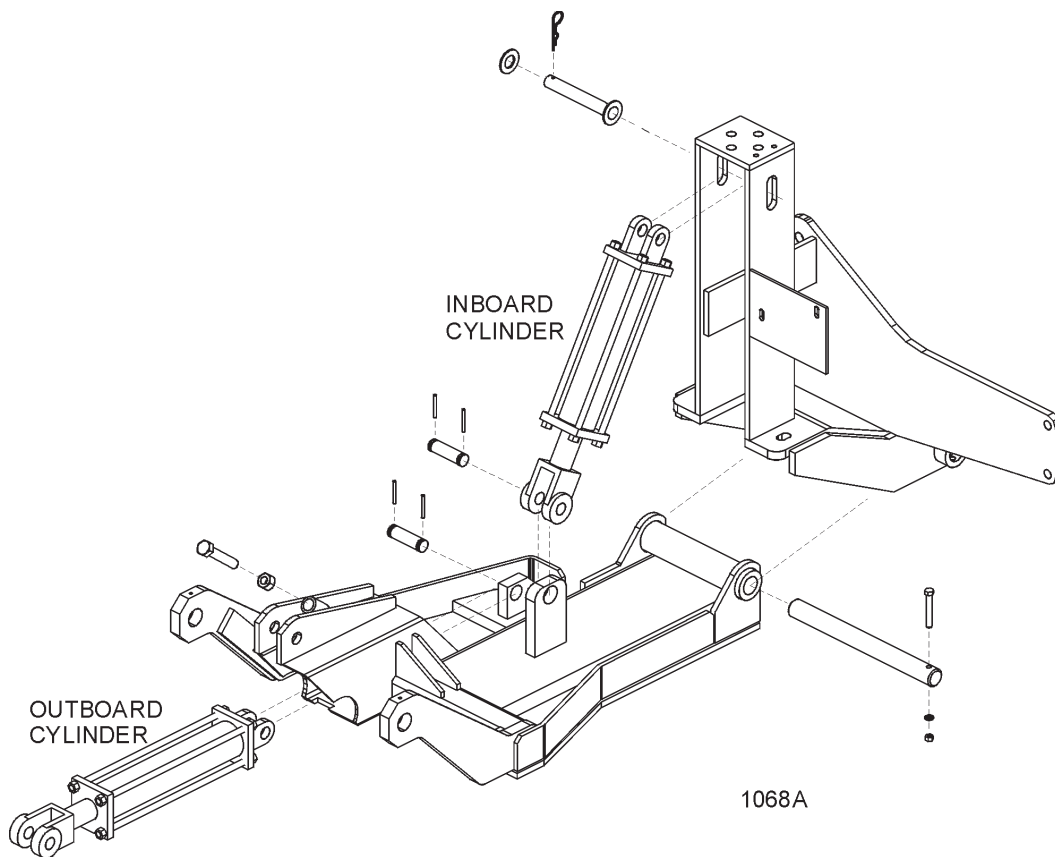

DRAFT BEAM MOUNTING

Pull the inboard cylinder piston rod down to the extreme extended position. Slide the draft beam under the cylinder, and align clevis hole with draft beam hole nearest to the tractor. Install pin and secure with rollpin.

Using inboard cylinder as a pivot point, slide draft beam under tractor and install draft beam pin. Align hole in draft beam pin with holes in main frame boss and install cap-screw, lock-washer and hex nut.

ASSEMBLY

DECK MOUNTING

Check that all grease zerks have been installed in the draft beams pivot arm, left linkage arm, right linkage arm, and cylinder mounting ears.

Using a clevis pin and roll pins, connect the pivot arm to clevis on draft beam.

NOTE: Make sure the longer distance between the cutout and the end of the pivot arm is closest to the draft beam pivot ears on the center tube as shown in the diagram below. Also make sure the cutout on the pivot arm faces into tube of draft beam.

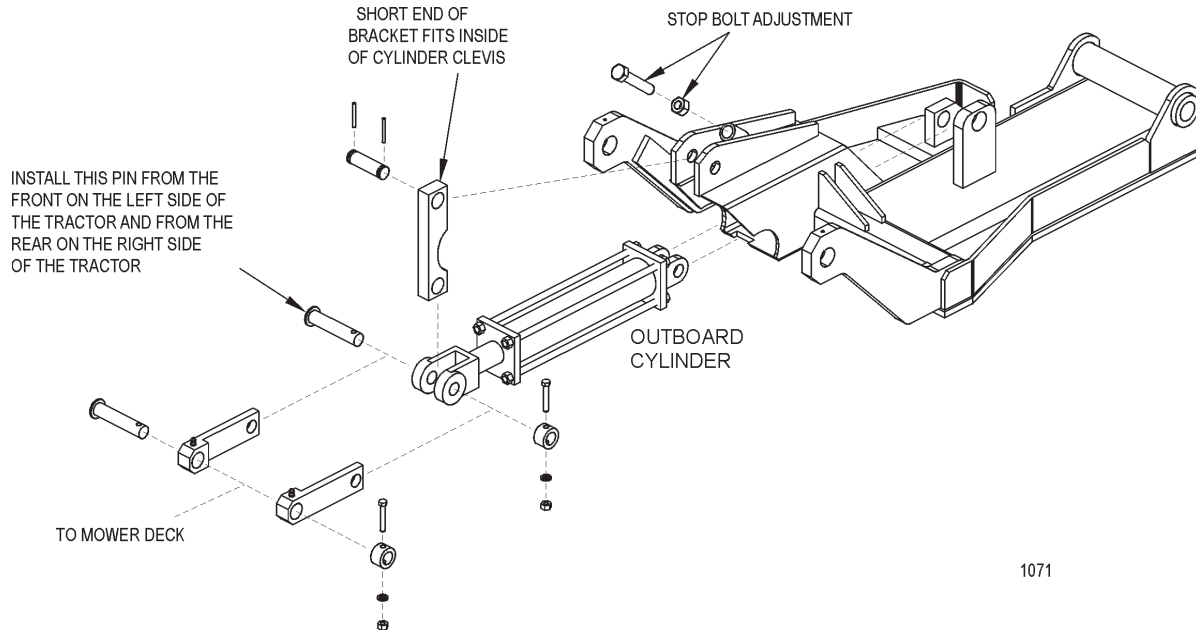

Slide other end of pivot arm with short distance between the cut-out and the end of the pivot arm, into the cylinder clevis. Next, line up the holes of the left and right lift linkage arms outside of the cylinder clevis holes. Connect with linkage pin, shims (as required), boss, cap-screw, lock-washer and hex nut as shown.

To connect the bonnet to the draft beam, slide the extension arms of the draft beam between the mounting ears on the inner end of the bonnet. Line up the holes and secure with swivel pin, cap-screw, lock-washer, and hex nut (both sides). See parts book illustration.

Next, slide the left and right linkage arms up to the slotted ear on the side of the deck. Secure with linkage pin, shims, boss, cap-screw, lock-washer and hex nut. See illustration in parts section.

LIFT CONTROL FEEDLINES

Hose lengths will vary between tractor applications such as cab and non-cab units. See the parts section that pertains to your tractor for hose applications.

Install a hose from the bottom or inner valve port (in fender well for cab units, on stand for non-cab units) to the restrictor on the inboard cylinder gland.

Install a hose from the upper or outer valve port to the restrictor on the outboard cylinder butt. Use teflon tape on all fitting and hose connections.

ASSEMBLY

DECK / MOTOR FEEDLINE

Install the 1" hoses from the motor to the solenoid valve. Refer to the parts section for detailed information about hoses and fittings for this application.

Install split hoses around hydraulic hoses where they contact sharp edges, or any other edges that may rub hoses.

Be sure that all grease zerks are installed in the draft beam pin bosses. Grease all areas of the draft beam according to the instructions in the maintenance section. Re-check all fittings for tightness and be sure teflon tape has been used at all connections.

Fill hydraulic tank with fluid as recommended in the maintenance section. **BE SURE TO OPEN THE BALL VALVES.** Start the tractor and operate the inboard cylinder through the entire stroke and the outboard cylinder through the bottom $\frac{3}{4}$ stroke repeatedly to clear the lines of air. **DO NOT run outboard cylinder out to full stroke until stop bolt has been adjusted!**

Check for oil leaks at all fittings and connections using a piece of paper or cardboard. If a leak is found, you must shut down the tractor and set the cutter head on the ground. Before attempting to fix the leak, you must actuate the lift valve handles several times to relieve any pressure in the lines. **DO NOT USE HANDS TO CHECK FOR FLUID LEAKS!**

Raise the three point hitch and check the tractor internal hydraulics, fill to proper level if needed.

STOP BOLT ADJUSTMENT

The stop bolt is not required on flail side mowers and should not be installed on the combo draft beam.

NOTE: When the outboard cylinder is fully extended, the bonnet should be up against the stop or if travel locks are installed, it should be up against the travel lock. It may be necessary to use either external or internal slugs on the cylinder to get the correct stroke. If the cutter head is against the stop and the cylinder has stroke remaining, serious damage will occur.

Proceed to final preparation for operation instructions on the next page.

ASSEMBLY

CONTINUOUS DUTY SOLENOID SWITCH

Mount the solenoid switch, drill holes to match, and 30 AMP breaker mounting tab, mount in dry and well protected area. Secure with 3/8" x 1" capscrews, lockwashers, and hex nuts.

A.) RED 6 GA. wire from terminal (D) to +12 volt battery post on starter solenoid.

B.) RED 14 GA. wire from terminal (C) to +12 terminal on fuel pump.

C.) GREEN 14 GA. wire from terminal (B) to negative ground.

D.) RED 8 GA. wire from terminal (A) to 30 AMP breaker.

E.) RED 14 GA. wire from terminal (A) to double switch box.

F.) RED 14 GA. wire from terminal (A) to temperature gauge. (optional)

G.) RED 8 GA. wire from breaker to reverser switch terminal (2).

H.) RED 8 GA. wire from terminal (1) to +12 volt terminal on cooler fan.

I.) BLACK 8 GA. wire from terminal (3) to ground on cooler fan.

J.) BLACK 8 GA. wire form terminal (4) to control panel ground.

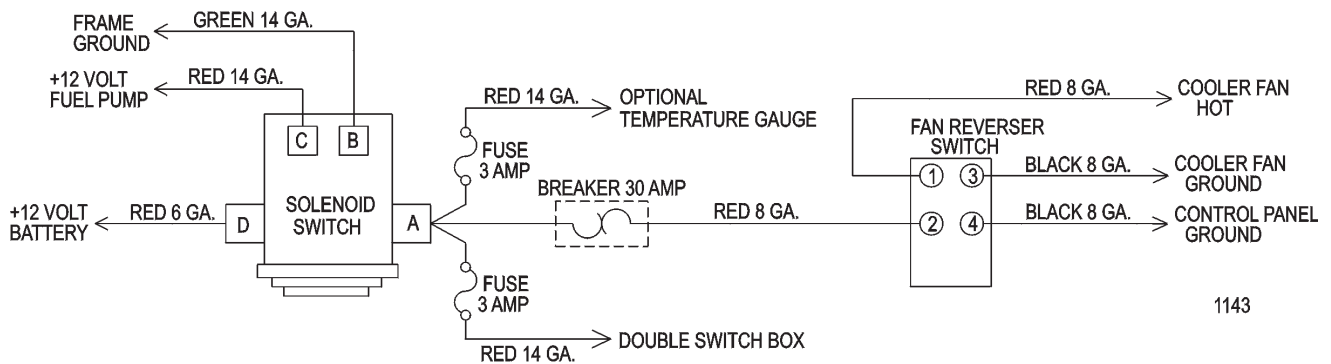

1143

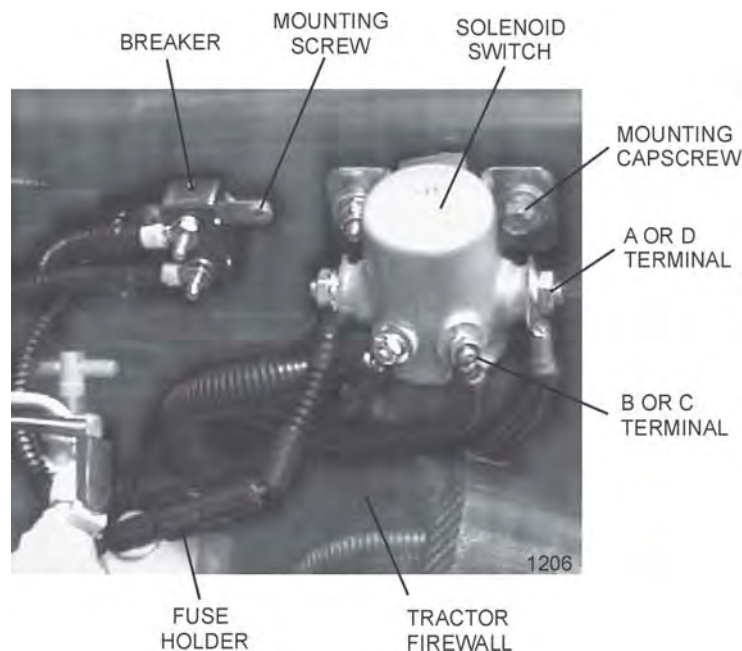

ASSEMBLY

FINAL PREPARATION FOR OPERATION

Place operators safety and operation decals on the steering column and side console where they are clearly visible to the operator. These decals should be understood by each operator of the machine in conjunction with the safety and operation section of this book. The decals are to remain in good condition as a reminder to the operator, and should be replaced if damaged.

Double check that all pivot points have been greased. Secure all hoses together with zip ties and wrap with split hose sections where friction may occur on the hose.

WARNING!



BEFORE starting or operating the tractor you must read and understand the safety and operation sections of this manual completely.

Before operating the mower, the cutter head and draft beam should be slowly moved throughout the full range of motion. Watch for any condition that would cause pinching or excess stress on the hoses. The steering and front axle travel should also be carefully moved through their full range of motion. If any condition occurs in which the hoses contact the tires, the steering and / or front axle travel may need to be limited as described in the tractor operators manual. This should also be done if the tires rub, or are extremely close to any other part of the mower such as the hydraulic tank or draft beam. This may include adding shims, or adjusting stop bolts in the tractor front to solve the problem. While checking motion, you should also check that the control circuits are connected according to the operators decal for the valve handles.

MOWER TESTING

Take the tractor to a place free of loose objects on the ground. Operate the cylinders through their full range of motion again, to clear the lines of air. Follow the instructions in the operation section to operate the mower. Vibration of the mower should be minimal at all times. After a 5 minute test run, the knife bolts should be retorqued and once again after the first few hours of operation.

If any parts of this assembly section, or any other section of this manual are not clearly understood you must contact your dealer or the address on the front of this manual for assistance!

OPERATION

**OPERATION
SECTION**

OPERATION

Safety is of primary importance to the owner / operator and to the manufacturer. The first section of this manual includes a list of Safety Messages, that, if followed, will help protect the operator and bystanders from injury or death. Many of the messages will be repeated throughout the manual. The owner / operator / dealer should know these Safety Messages before assembly and be aware of the hazards of operating this mower during assembly, use, and maintenance.

The **Safety Alert Symbol** combined with a signal word, as seen below, is intended to warn the owner / operator of impending hazards and the degree of injury possible during operation.

DANGER!



Indicates an imminently hazardous situation that, if not avoided, WILL result in DEATH OR VERY SERIOUS INJURY.

WARNING!



Indicates an imminently hazardous situation that, if not avoided, COULD result in DEATH OR SERIOUS INJURY.

CAUTION!



Indicates an imminently hazardous situation that, if not avoided, MAY result in MINOR INJURY.

IMPORTANT!

Identifies special instructions or procedures that, if not strictly observed, could result in damage to, or destruction of the machine, attachments or the environment.

NOTE: *Identifies points of particular interest for more efficient or convenient operation or repair.* (SG-1)

CAUTION!



Before any operation of tractor and mower, the user should read and understand the safety and operating instructions for both the tractor and the mower. The user should also be familiar with the location and functions of the units instruments and controls. Being familiar with the machine and its controls will increase efficiency and reduce possibility of serious injury or damage to the unit. The operator should work slowly and carefully until he feels comfortable with the machine. Speed and skill will be attained much easier if the necessary time is spent to familiarize yourself with the machine and its operations.

Since tractor makes and models vary, we recommend reading and following the operators manual provided by the manufacturer pertaining to your particular unit.

OPERATION



STARTING TRACTOR AND MOWER



Check the operators manual received from the tractor manufacturer, for their recommendation and procedures pertaining to your particular make and model.

WARNING!



When rotating parts are in motion, serious injury may occur if caution is not used or danger is not recognized. Never allow bystanders within **300 feet** of the machine when mower is in operation.



Be sure the ball valves on the mower hydraulic tank are **OPEN** before starting the tractor. Serious damage to the hydraulic system can occur if the valves are not open.

WARNING!



Check to make sure mower switch is in the “**OFF**” position. The unit is designed not to start if the switch is in the “on” position. If tractor starts with switch on, turn off tractor and contact your local Tiger dealership for assistance.

Start the tractor and allow the instruments to stabilize. Without starting the mower, practice positioning the boom and deck. Remember, speed and skill will be attained easier if the necessary time is spent familiarizing yourself with the machine and its operations. When you feel comfortable at controlling the position of the mower, return the mower to the travel position, and transport the mower to the desired mowing location.

If mowing for the first time with a Tiger Boom Mower, we recommend choosing a ditch or area relatively flat with a minimum of sign posts, guard rails, etc. As always, you should inspect the area for other objects that can cause potential hazards.

The Mower Control switch turns the mower “ON” and “OFF”. This switch is to be in the “OFF” position to start the tractor. The tractor will not start with the switch in the “ON” position.

WARNING!



If tractor starts with switch on, turn off tractor and contact your local Tiger dealership for assistance.

CONTROL LOCATION AND FUNCTIONS

The left and right mower height is controlled with a four spool valve and is coordinated as shown below. Always mow with the controls in the float position. Be sure to install the travel lock pins whenever the mower is to be transported by truck and trailer.

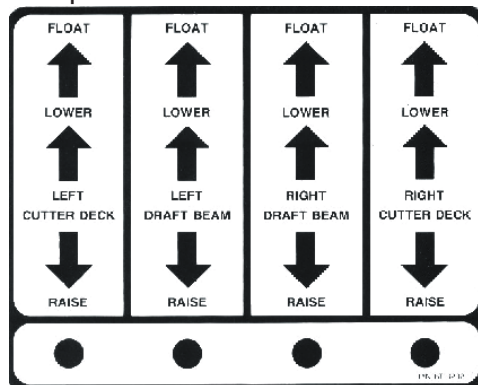

OPERATION

The rear mower height is controlled with the 3-point hitch control lever. Follow the instructions for this control in the tractor operators manual. The tilt of the rear mower is controlled with the third spool if the lift valve and is coordinated as shown above.

The left and right mower on/off switches are mounted to the four spool valve or the cable controls for cab and non-cab units respectively. Read and follow the mower operation section closely for instructions on how to operate them.

This machine may be equipped with an auxiliary oil temperature gauge, an amp gauge or oil pressure gauge. If oil temperature reaches 200 degrees Fahrenheit, stop mowers and see trouble shooting section for possible causes. Keep an eye on all gauges for indication of problems.

MOWER OPERATION

WARNING!



When rotating parts are in motion, serious injury may occur if caution is not used or danger is not recognized. Never allow bystanders within **300 feet** of the machine when in operation. Extreme care should be taken when operating near loose objects – such as gravel, rocks and debris. These conditions should be avoided.

The rotating parts in this machine have been designed and tested for rugged use. However, they could fail upon impact with heavy solid objects – such as steel guard rails, concrete abutments, etc., causing them to be thrown at a very high velocity. Never allow cutter head to contact such objects. Inspecting the cutting area for such objects prior to mowing can help eliminate these potential hazards.

Once on location, lower the mower deck slightly above the material to be cut, so the mower does not have to start under a load. Bring the R.P.M. of the tractor up to 1200 and engage the side mower. If a rear mower is being used, allow the R.P.M. to return to 1200 before engaging the rear mower.

The flail mower deck should be carried so that part of the weight is carried by the ground roller. When the flail is carried this way, the roller also follows the contour of the ground more easily during mowing operations.

When cutting small shrubs or brush, begin each pass at the top of the material and work down with each consecutive pass. Use a low speed to allow the cutting blades time to mulch as well as cut the foliage. When the initial pass has been made, disengage the mower and return the mower to the travel position. Return to the starting point and make next pass, etc. The flail head is not intended for cutting heavy brush, or for continually cutting brush. Wear or damage of the blades will occur rapidly when the flail cutter is used this way.

To ensure a clean cut, engine speed should be maintained at approximately 1800 – 2200 R.P.M. If the tractor slows to less than 1800 R.P.M., shift to the next lower gear. **DO NOT** ride the clutch, this will cause premature clutch failure. **The engine should not be operated at any time at more than 2400 R.P.M. on the tractor tachometer.**

OPERATION

The mower will operate more efficiently in tougher conditions and with less power if the knives are kept sharp. If the mower begins to vibrate, stop the tractor, check for wire wrapped in the spindle or damaged knives. When replacing knives, replace all knives with new knives to ensure proper balance so the mower will not vibrate. Severe vibration will result, if knives with unequal wear are used. Follow the instructions in the maintenance section closely when replacing knife blades.

WARNING!



If bystanders approach within 300 feet while mower is in operation turn mower switch "OFF" immediately! After shutdown, never leave the tractor or allow bystanders to approach within **300 FEET** of the unit until all motion stops completely.

When encountering a very severe condition which causes the tractor to stall, disengage mower, start tractor, raise the mower from the cut. Shut tractor off and inspect the mower, blades and disk for damage before engaging mower again.

If the blades jam or stop, disengage the clutch and raise the head slightly or back the tractor up. Normally, this will clear the cutter head. If not, shut off the mower(s), raise the cutter heads, turn off the tractor and set the parking brake. After all motion stops completely, leave the tractor and clear the cutting heads manually.

After the first day of operation, all bolts should be checked and tightened securely. This should be done periodically to ensure the bolts do not become loose and cause damage to the tractor or mower, or injury to the operator. Also be sure to lubricate the unit as instructed in the maintenance section.

REVERSE FAN OPERATION

Normal operation - Operating position is with fan switch ON (upper position)

Reversing fan to clear chaff -Reverser fan switch is to be used as follows as necessary for clearing chaff from cooling fins:

1. Normal operating position is with fan switch ON (upper position)
2. Turn fan switch OFF (center position), wait at least 3 seconds
3. Push switch DOWN to reverse,
4. Allow chaff to clear
5. Turn fan switch OFF (center position), wait at least 3 seconds
6. Turn fan switch to ON (upper position)

OPERATION

TRANSPORTING MOWER

Transporting under the units own power:

When transporting between job sites or between cutting passes, the following procedure should be followed: Shut off the power to the cutting head(s) and allow all motion to come to a complete stop. Raise the draft beam to it's highest position. Raise the side mower until the deck stops against the draft beam. Raise the rear mower with the 3-point hitch control lever. The unit is now in position for self transportation.

Transporting unit by flatbed trailer:

Most tractors with a side mounted mower head attached will be over legal transporting width (102" wide). For this reason, one of the following procedures must be followed.

1: Transporting with side mower attached: Use a loading dock or ramp to load tractor onto the trailer. Center the tractor with the mowers attached between the sides of the trailer. Make sure the draft beam and head are fully raised and secured. Lower the rear mower onto the trailer. Secure the tractor and rear mower to the trailer with chains. Obtain proper over-width permits and mark the vehicle and mower as over-width as required be law. Check the tractor operators manual for any tractor requirements to transport by flatbed trailer.

2: Transporting with side mower removed: Park the tractor and turn the engine off. Remove the key to avoid accidental starting. Close ball valves on the hydraulic reservoir. To avoid contaminating the hydraulic system, make sure all fittings on the side mower motor and solenoid control valve are clean. Disconnect the motor pressure hose at the solenoid valve and the motor return hose at the motor. See diagram below.

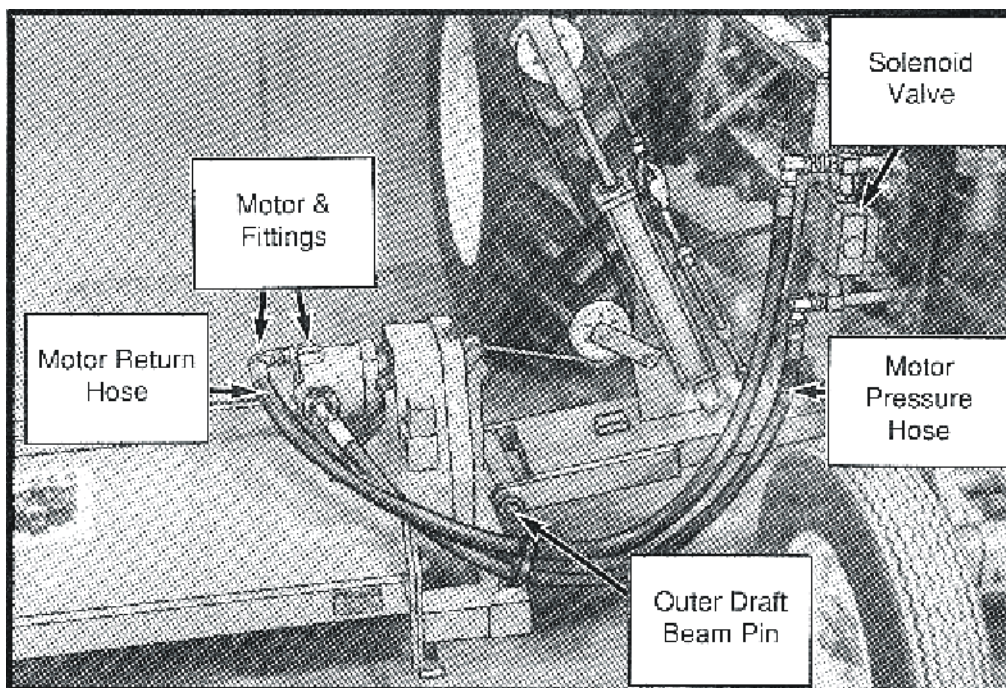

OPERATION

Next, switch the hose ends and reconnect to form two separate closed loops, see diagram below. Disconnect the lift cable from the head and secure the loose end back onto the cable with the cable clevis. Remove the keeper bolt and draft beam outer pivot pin. Separate the mower head from the tractor. Now reinstall the pivot pin and keeper bolts into the draft beam to prevent loss. **OPEN THE BALL VALVES ON THE HYDRAULIC RESERVOIR BEFORE STARTING TRACTOR AGAIN!** Serious damage will be caused if tractor is started with the ball valves closed.

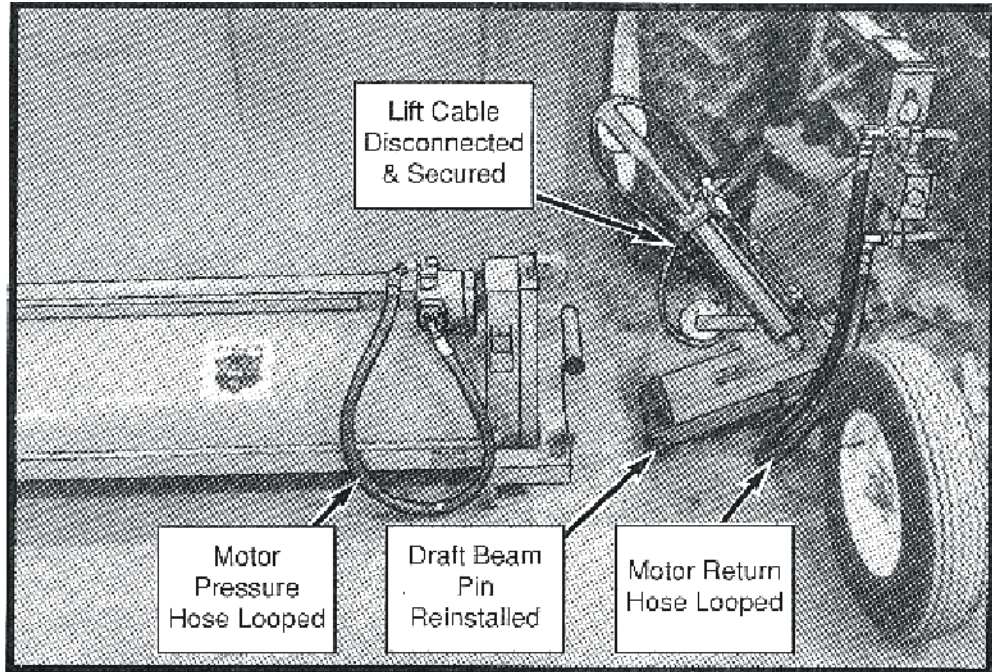

Use a loading dock or ramps to load the tractor onto the trailer, centering the tractor between the sides of the trailer. Make sure the tractor (and rear mower) and trailer are within legal transporting width. Lower the rear mower onto the trailer and set the loose hide mower on the trailer. Secure the tractor and mowers to the trailer with chains. Check the tractor operators manual for any requirements to transport be flatbed trailer. Reverse this procedure to unload and remount the mowers after transporting. Be sure all pins are secure, all connections are tight and any lost fluid is replaced before using mowers. Use teflon tape when connecting all fittings.

CAUTION!



If any part of this operating section, or any other section of this manual is not completely understood, contact your Tiger dealer or the address on the cover of this manual for assistance!

OPERATION

11.6 Setting Reverse Rotation

When you set up the flail mower so that the cutter shaft is rotating in the reverse rotation (opposite direction of the tractor tire rolling forward), you will need to do the following;

First, start by removing the PTO Shaft(1) and PTO Shield(2), bolts(3), lockwasher & flatwasher(4).

Then remove the four bolts(5) and lockwashers(6) attaching the output shaft guard(7).

Remove the four bolts(8) and lockwashers (9) attaching the gearbox (10) to the flail driveline(11).

Next remove the four gearbox bolts(12) and lockwashers(13) from mounting plate(14).

Once Gearbox is loose, slide it out of flail driveline(11). Rotate gearbox 180° to the right until the reverse rotation input shaft(15) is aligned in the position that the normal rotation input shaft(16) originally was. Grab the gearbox from the end of the bearing housing output shaft(17) and flip the entire gearbox to the left.

Align the bearing housing output shaft(17) with the flail driveline(11) and make sure that the output shaft is set correctly with the spline coupling inside the shaft guard.

Once aligned, loosely reattach flail driveline bolts(8) and lockwashers(9). Do not tighten at this time.

Attach the gearbox bolts(12) and lockwashers(13) to the mounting plate(14), and tighten.

Once gearbox is tightened go back to the flail driveline and tighten bolts and lockwashers.

Next, attach the input shaft guard to the normal rotation input shaft.

Then reattach the PTO Shield and PTO Shaft to gearbox.

Finally, remove front rubber guard and attach the Reverse Rotation Front Guard to flail.



Do not operate mower when the cutter shaft is in reverse rotation unless:

- Reverse Rotation Front Guard is in place, and
- The guard is in good working condition.

All safety devices should be inspected carefully at least daily for missing or broken components. Missing, broken, or worn items must be replaced at once to reduce the possibility of injury or death from thrown objects, entanglement, or blade contact. (SFL-8)

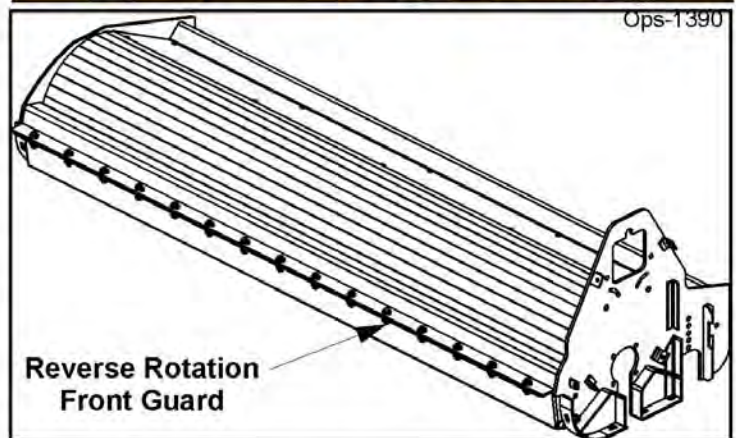
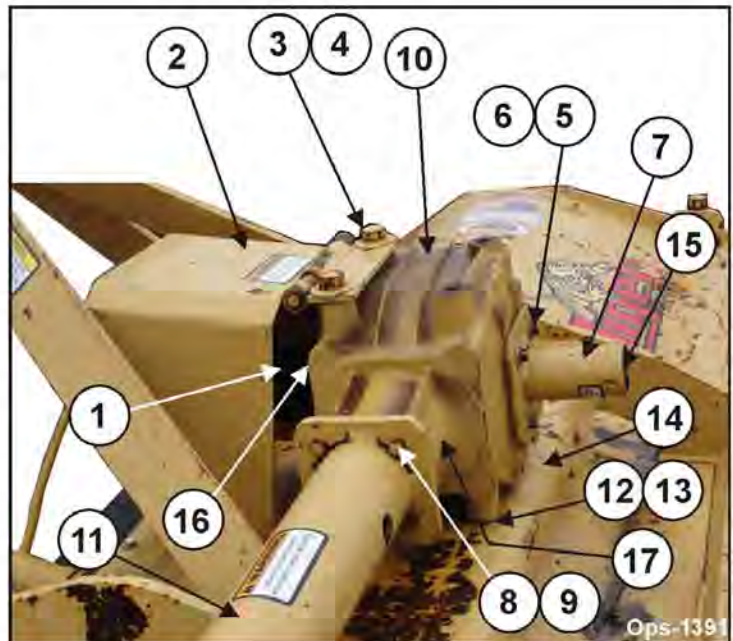

OPERATION INSPECTION SHEETS

Flail Mower PRE-OPERATION Inspection



Tractor ID# _____ Make _____

Date: _____ Shift _____

WARNING!



Before conducting the inspection, make sure the Tractor engine is off, all rotation has stop and the tractor is in the Park with the parking brake engaged. The Mower head is resting on the ground (or is securely blocked up and supported) and all hydraulic pressure has been relieved.

Item	Condition at Start of Shift	Specific Comments if not O.K.
The Operator's Manual is in the Canister on the mower		
All Safety Decals are in place and legible		
The Hitch connection bolts & pins are tight		
There are no cracks in Hitch		
There mower deck is clear of cut grass and debris		
The Thrown object Guards/Deflectors are in place		
There Guards/Deflectors are in good condition		
The Driveline/Gearbox shields are in good condition		
The Driveline clutch is in good condition, not frozen		
The driveline tubes & u-joints have been lubricated		
The Driveline yoke is securely attached to the PTO		
The Gearbox oil level is full		
Blades are not broken, chipped, cracked or bent		
Blade shackles are in good condition with no cracks		
The Blade pins are properly retained		
The Skid shoes are in good condition & tight		
The Rear Roller is in good condition and turns freely		

Operators Signature: _____

DO NOT OPERATE an UNSAFE TRACTOR or MOWER

OPERATION

TRACTOR PRE-OPERATION Inspection



Tractor ID# _____ Make _____

Date: _____ Shift _____

WARNING!



Before conducting the inspection, make sure the Tractor engine is off, all rotation has stop and the tractor is in the Park with the parking brake engaged. The Mower head is resting on the ground (or is securely blocked up and supported) and all hydraulic pressure has been relieved.

Item	Condition at Start of Shift	Specific Comments if not O.K.
The Flashing lights function properly		
The SMV Sign is clean and visible		
The Tires are in good condition with proper pressure		
The Wheel Lug bolts are tight		
The tractor Brakes are in good condition		
The Steering linkage is in good condition		
There are no visible Oil Leaks		
The Hydraulic controls function properly		
The ROPS or ROPS Cab is in good condition		
The Seatbelt is in place and in good condition		
The 3-Point Hitch is in good condition		
The Drawbar pins are securely in place		
The PTO Master Shield is in place		
The Engine Oil level is full		
The Brake Fluid level is full		
The Power Steering Fluid Level is full		
The Fuel level is adequate		
The Engine Coolant Fluid level is full		
The Radiator is free of debris		
The Air filter is in good condition		

Operators Signature: _____

DO NOT OPERATE an UNSAFE TRACTOR or MOWER

OPERATION

FRONT END LOADER PRE-OPERATION Inspection



Mower ID# _____ Make _____

Date: _____ Shift _____

WARNING!



Before conducting the inspection, make sure the Tractor engine is off, all rotation has stop and the tractor is in the Park with the parking brake engaged. The Loader is resting on the ground (or is securely blocked up and supported) and all hydraulic pressure has been relieved.

Item	Condition at Start of Shift	Specific Comments if not O.K.
The Operator's Manual is in the Canister on the mower		
All Safety Decals are in place and legible		
The Mounting frame bolts are in place and tight		
There are no cracks in Draftbeam or Yolk		
The Draftbeam/Yolk connection bolts & pins are tight		
There are no cracks or holes in mower deck		
The Hydraulic motor mounting bolts are tight		
The mower head spindle housing is tight and lubricated		
There mower deck is clear of cut grass and debris		
The Skid shoes are in good condition & tight		
Chain Guards/Deflectors are in place & in good condition		
Blade carrier retaining nut is tight		
Blades are not chipped, cracked or bent		
Blade bolts are tight		
Transport locks are in good condition		
There are no leaking or damaged hoses		
There is no evidence of Hydraulic leaks		
The Hydraulic Oil level is full		
The Hydraulic Cylinders pins are tight		
The Hydraulic Pump hose connections are tight		
The Hydraulic Valve hose connections are tight		
The Hydraulic Valve controls function properly		
Wheel lug nuts are tight		

Operators Signature: _____

DO NOT OPERATE an UNSAFE TRACTOR or FRONT END LOADER

OPERATION

TRACTOR PRE-OPERATION Inspection



Tractor ID# _____ Make _____

Date: _____ Shift _____

WARNING!



Before conducting the inspection, make sure the Tractor engine is off, all rotation has stop and the tractor is in the Park with the parking brake engaged. The Loader is resting on the ground (or is securely blocked up and supported) and all hydraulic pressure has been relieved.

Item	Condition at Start of Shift	Specific Comments if not O.K.
The Flashing lights function properly		
The SMV Sign is clean and visible		
The Tires are in good condition with proper pressure		
The Wheel Lug bolts are tight		
The Tractor Brakes are in good condition		
The Steering linkage is in good condition		
There are no visible Oil Leaks		
The Hydraulic controls function properly		
The ROPS or ROPS Cab is in good condition		
The Seatbelt is in place and in good condition		
The PTO Master Shield is in place		
The Engine Oil level is full		
The Brake Fluid level is full		
The Power Steering Fluid Level is full		
The Fuel level is adequate		
The Engine Coolant Fluid level is full		
The Radiator is free of debris		
The Air filter is in good condition		

Operators Signature: _____

**DO NOT OPERATE an UNSAFE TRACTOR or FRONT END
LOADER**

MAINTENANCE

MAINTENANCE SECTION

MAINTENANCE

Tiger Mowers are designed for high performance and rugged durability, yet with simplified maintenance. The purpose of this section of the manual is to help the operator in the regular servicing of the mower. Regular maintenance at the intervals mentioned will result in the maximum efficiency and long life of the Tiger Mower.

When you purchase a Tiger Mower you also acquire another valuable asset, Tiger's parts organization. Our rapid and efficient service has guaranteed the customer satisfaction for many years. Tiger parts keep up with the demands for efficiency, safety and endurance expected of the Tiger Mower.

MAINTENANCE PRECAUTIONS

- Be sure end of grease gun and zerks are clean before using. Debris injected into bearings, etc. with grease will cause immediate damage.
- DO NOT use a power grease gun to lubricate bearings. These require very small and exact amounts of lubrication. Refer to the detailed maintenance section for specific lubrication instructions. Do Not over-grease bearings.
- Lexan windows should be washed with mild soap or detergent and luke warm water, using a soft clean sponge or **soft cloth**. DO NOT use abrasive or alkaline cleaners or metal scrapers on lexan windows!
- Be alert to maintenance indicators such as the in-tank filter pressure gauge, hydraulic reservoir sight gauge, etc. Take the required action to correct any problems immediately.
- Release of energy from pressurized systems may cause inadvertent actuation of cylinders, or sudden release of compressed springs. Before disconnecting any hoses relieve pressure by shutting tractor off, setting cutter on ground and actuating lift valve handles.

WARNING!



DO NOT use hands to check for suspected leaks in hydraulic hoses! Hydraulic fluid escaping under pressure can have sufficient force to penetrate skin and cause serious injury. If fluid is injected into skin, it must be surgically removed within a few hours or gangrene may result. Use a small piece of wood or cardboard, not hands, to search for pin hose leaks. Be sure all pressure is relieved whenever disconnecting lines. Be sure all connections are tight and hoses and lines are not damaged before applying pressure.

BREAK IN PERIOD

In addition to following the break in instructions for your particular tractor, the in-tank hydraulic fluid filter should be replaced after the first 50 hours of service. Thereafter the filter should be replaced every 500 hours, or yearly, whichever comes first.

Re-torque wheel lugs after first five hours of operation and periodically thereafter. See torque specifications listed in the tractor's service manual for your particular model. **Wheel lugs must always be re-torqued whenever a wheel is removed and reinstalled.**

MAINTENANCE

REGULAR MAINTENANCE

The intervals at which regular servicing should be done are based on hours of operation. Use the tractors hour meter to determine when regular servicing is required.



This symbol indicates a point that needs to be greased at an interval noted in the section below. Refer to the Detailed Maintenance section for further instructions on greasing. Copy and use the Daily Maintenance sheet located at the end of this section.

DAILY OR EVERY 8 HOURS

ITEM	SERVICE	COMMENTS
Drive Shaft Yoke, U-Joint & Stub Shaft	Grease	Grease as instructed in detailed maint. section
Pump Drive Shaft	Check and Lube	Insure drive shaft end play
Crankshaft Adapter	Check rubber grommets	Replace grommets if damaged or missing
Pivot Points	Lubricate	Inject grease until it appears at ends
Hydraulic Fittings	Check for leaks	Tighten when needed. Do Not use hands to check for leaks, see maintenance Precautions
Knives	Check	Inspect for missing or damaged knives, change or sharpen as needed
Cutter shaft mounting bolts (cutter shaft to deck)	Check	1/2" x 2" torque to 84 ft. lbs.
Knife mounting bolts (knife to cutter shaft)	Check	Retorque to knife replacement specifications
Belts	Check / Adjust	Check if broken, tighten as required
Main Frame and Deck	Check	Retorque bolts to troque specifications in this section
Hydraulic Fluid Level	Check	Add if required per fluid recommendations
Rear Flail Drive (if applicable) Bearing Flange and Shaft Coupler	Lubricate	Grease as instructed in detailed maint. section
Cutter Shaft and Ground Roller	Lubricate	Grease as instructed in detailed maint. section

MAINTENANCE

WEEKLY OR EVERY 50 HOURS

ITEM	SERVICE	COMMENTS
In Tank Hyd. Fluid Filter (10 micron filter)	Change	Change after first 50 hours only, then every 500 hours or yearly
In-Line High Pressure Filter (10 micron filter)	Change	Change after first 50 hours only, then every 500 hours or yearly

MONTHLY OR EVERY 150 HOURS

Hydraulic Fluid Level	Check	Add as needed
Hyd. Tank Breather	Clean / Check / Replace	Clean or replace Element as required
Rear Tire Type	Max P.S.I.	
480/80R38	29	
18.4-34	26	
18.4-38	26	

YEARLY OR EVERY 500 HOURS

Hyd. Tank Fluid	Change	
In Tank Hyd. Fluid Filter (10 micron filter)	Change	
In-Line High Pressure Filter (10 micron filter)	Change	or Change when indicated by restriction indicator.
Hyd. Tank Breather	Change	

TROUBLE SHOOTING

SYMPTOMS	CAUSE	REMEDY
Vibration	1. Loose bolts	1. Check all bolts and tighten to torque specs. in this section.
	2. Cutter assembly Unbalanced	2a. Check for damaged blades, disc. or cutter shaft. Replace if needed. 2b. Check for wire, rope, etc. entangled in cutter assembly.
Mower will not lift	1. Hyd. Fluid low	1. Check and refill Hyd. Fluid.
	2. Leaks in line	2. Tighten or replace fittings and hoses
	3. Faulty relief valve	3. Check pressure in line. Line pressure in Control Valve should be at least 2500 P.S.I.
	4. Kinked or blocked	4. Clean or replace lines.
	5. Faulty cylinder	5. Inspect, repair or replace cylinder.

MAINTENANCE

SYMPTOMS	CAUSE	REMEDY
Oil Temperature rises above 200 deg. F	<ol style="list-style-type: none"> 1. Low oil level 2. Kinked/blocked hoses 3. Worn pump / motor 	<ol style="list-style-type: none"> 1. Bring oil to proper level 2. Inspect, Repair, or Replace 3. Disable and repair
Mower will not start or run	<ol style="list-style-type: none"> 1. Blown fuse 2. Ball valves closed 3. Low oil level 4. Line leak 5. Electronic solenoid faulty 	<ol style="list-style-type: none"> 1. Check fuse between mower switch and ignition / replace. 2. Make sure valves are open. 3. Check Hyd. tank level and fill 4. Check all fittings and lines, re-tighten or replace. 5a. Without the tractor running, turn the mower switch to on. A low audible click should be heard if the solenoid is engaging the solenoid spool. If click is not heard, leave switch in on position and with a screwdriver or other steel object, touch the small nut on the end of the solenoid. If the metallic object is not attracted to the nut, check the fuse and wiring for an open circuit. If the object is attracted but no "click" is heard, replace the solenoid. 5b. Remove the four bolts holding the small block to the main block. Lift and remove small block being careful not to damage O-rings / filter. Clean filter and re-install. 5c. Remove large nut on side of large valve block. Remove spring, and use needle nose vise grip to pull spool from block. Check block and spool for contaminates and scratches. Clean parts or replace if scratched.
Motor runs but will not cut.	<ol style="list-style-type: none"> 1. Belts 2. Tensioner 	<ol style="list-style-type: none"> 1. Inspect belts and pulleys. Replace belts and repair as needed. 2. Adjust tensioner nut until flat washer washer is flush with top of guide.
Motor turns slowly or not at all.	<ol style="list-style-type: none"> 1. Contaminants restricting spool movement in valve body. 2. Suction lines obstructed 3. Low oil level 	<ol style="list-style-type: none"> 1. Remove large nut on side of large valve block. Remove spring, and use needle nose vise grip to pull spool from block. Check block and spool for contaminates and scratches. Clean parts or replace if scratched. 2. Check for kinkes or obstruction in suction hose 3. Check Hyd. tank level and fill
Pump will not work	<ol style="list-style-type: none"> 1. Excessive wear on internal parts 	<ol style="list-style-type: none"> 1. Disassemble and repair.

MAINTENANCE

Motor will not work

1. Excessive wear on internal parts
 1. Disassemble and repair.
-





NOTE: If flow meter is available, check pressure and flow volume for all suspected hydraulic problems.

If the solution to your problem cannot be found in this section, call the Technical Service representative at the number shown on the front cover of this manual.

MAINTENANCE

TORQUE SPECIFICATIONS

Torque for Standard Fasteners





Nominal Dia. (in.)	threads per inch	 Grade 2			 Grade 5			 Grade 8			 Grade 9		
		Tightening Torque			Tightening Torque			Tightening Torque			Tightening Torque		
		Lubed	Dry Plated	Dry plain	Lubed	Dry Plated	Dry plain	Lubed	Dry Plated	Dry plain	Lubed	Dry Plated	Dry plain
		K = 0.15	K = 0.17	K = 0.20	K = 0.15	K = 0.17	K = 0.20	K = 0.15	K = 0.17	K = 0.20	K = 0.15	K = 0.17	K = 0.20
Unified Coarse Thread Series													
1/4	20	49 in.-lbs	59 in.-lbs	66 in.-lbs	76 in.-lbs	86 in.-lbs	101 in.-lbs	107 in.-lbs	122 in.-lbs	143 in.-lbs	126 in.-lbs	143 in.-lbs	168 in.-lbs
5/16	18	101	122	135	157	178	209	221	251	295	259	294	346
3/8	16	15 ft.-lbs	18 ft.-lbs	20 ft.-lbs	23 ft.-lbs	26 ft.-lbs	31 ft.-lbs	33 ft.-lbs	37 ft.-lbs	44 ft.-lbs	38 ft.-lbs	43 ft.-lbs	51 ft.-lbs
7/16	14	24	29	32	37	42	49	52	59	70	61	70	82
1/2	13	37	44	49	57	64	75	80	90	106	94	106	125
9/16	12	53	63	70	82	92	109	115	130	154	135	153	160
5/8	11	73	87	97	113	128	150	159	180	212	186	211	248
3/4	10	129	155	172	200	227	267	282	320	376	331	375	441
7/8	9	125	150	167	322	365	429	455	515	606	533	604	710
1	8	187	225	250	483	547	644	681	772	909	799	905	1085
1 1/8	7	265	319	354	596	675	794	866	1095	1288	1132	1283	1510
1 1/4	7	375	450	500	840	952	1121	1163	1545	1817	1597	1810	2130
1 1/2	6	652	783	869	1462	1657	1950	2037	2688	3152	2779	3150	3706

Fine Thread Series

1/4	28	56 in.-lbs	68 in.-lbs	75 in.-lbs	87 in.-lbs	99 in.-lbs	116 in.-lbs	123 in.-lbs	139 in.-lbs	164 in.-lbs	144 in.-lbs	163 in.-lbs	192 in.-lbs
5/16	24	112	135	150	174	197	231	245	278	327	287	325	383
3/8	24	17 ft.-lbs	20 ft.-lbs	23 ft.-lbs	26 ft.-lbs	30 ft.-lbs	35 ft.-lbs	37 ft.-lbs	42 ft.-lbs	49 ft.-lbs	43 ft.-lbs	49 ft.-lbs	58 ft.-lbs
7/16	20	27	32	36	41	47	55	58	66	78	68	78	91
1/2	20	41	49	55	64	72	85	90	102	120	105	120	141
9/16	18	59	71	78	91	103	121	128	146	171	151	171	201
5/8	18	82	99	110	127	144	170	180	204	240	211	239	281
3/4	16	144	173	192	223	253	297	315	357	420	369	418	492
7/8	14	138	165	184	214	243	291	310	357	425	373	424	505
1	14	210	252	280	327	374	452	481	557	665	586	665	795
1 1/8	12	298	357	397	468	537	648	687	802	960	843	960	1155
1 1/4	12	415	498	553	645	738	891	945	1113	1344	1176	1344	1617
1 1/2	12	734	880	978	1165	1315	1591	1695	2002	2412	2109	2412	2895

Torque values for 1/4 and 5/16-in series are in inch-pounds. All other torque values are in foot-pounds. K = 0.15 for "lubricated" conditions D = Nominal Diameter
 Torque values calculated from formula T=KDF, where K = 0.17 for zinc plated and dry conditions F = Clamp Load
 K = 0.20 for plain and dry conditions

Torque-Tension Relationship for Metric Fasteners

Nominal Dia. (mm)	Pitch (mm)	 Class 4.6			 Class 8.8			 Class 10.9			 Class 12.9		
		Tightening Torque			Tightening Torque			Tightening Torque			Tightening Torque		
		Lubed	Dry Plated	Dry plain	Lubed	Dry Plated	Dry plain	Lubed	Dry Plated	Dry plain	Lubed	Dry Plated	Dry plain
		K = 0.15	K = 0.17	K = 0.20	K = 0.15	K = 0.17	K = 0.20	K = 0.15	K = 0.17	K = 0.20	K = 0.15	K = 0.20	
		(ft.-lbs)	(ft.-lbs)	(ft.-lbs)	(ft.-lbs)	(ft.-lbs)	(ft.-lbs)	(ft.-lbs)	(ft.-lbs)	(ft.-lbs)	(ft.-lbs)	(ft.-lbs)	
3	0.5	0.28	0.32	0.38	0.73	0.82	0.97	1.0	1.2	1.4	1.2	1.6	
3.5	0.6	0.44	0.50	0.59	1.1	1.3	1.5	1.6	1.9	2.2	1.9	2.5	
4	0.7	0.66	0.74	0.87	1.7	1.9	2.3	2.4	2.7	3.2	2.8	3.8	
5	0.8	1.3	1.5	1.8	3.4	3.9	4.5	4.9	5.5	6.5	5.7	7.6	
6	1	2.3	2.6	3.0	5.8	6.6	7.7	8.3	9.4	11	9.7	13	
6	1.25	2.1	2.3	2.7	5.3	6.0	7.0	7.6	8.6	10	8.8	12	
7	1	3.8	4.3	5.0	9.7	11	13	14	16	19	16	22	
8	1	5.9	6.6	7.8	15	17	20	22	24	29	25	34	
8	1.25	5.5	6.2	7.3	14	16	19	20	23	27	24	31	
10	1.25	11	13	15	29	33	39	42	48	56	49	66	
10	1.5	11	12	14	28	32	37	40	45	53	47	62	
12	1.25	21	23	28	53	60	71	76	88	101	89	119	
12	1.5	20	22	26	51	58	68	73	82	97	85	113	
12	1.75	19	21	25	49	55	65	70	79	93	81	108	
14	1.25	26	29	34	66	75	89	95	108	127	111	148	
14	1.5	28	32	37	72	82	96	103	117	138	121	161	
14	2	30	34	40	78	88	104	111	126	148	130	173	
16	1.5	50	57	67	129	146	171	184	208	245	215	287	
16	2	47	53	62	121	137	161	173	196	230	202	269	
18	1.5	73	82	97	187	212	249	268	303	357	313	417	
18	2.5	65	73	86	167	189	222	239	270	318	279	372	
20	2.5	91	104	122	236	267	314	337	382	449	394	525	

Clamp load calculated as 75% of the proof load for specified bolts: K = 0.15 for "lubricated" conditions D = Nominal Diameter
 All torque values are listed in foot-pounds K = 0.17 for zinc plated, dry conditions F = Clamp Load
 Torque values calculated from formula T=KDF, where K = 0.20 for plain and dry conditions

* These are intended to be general specifications. See tractor operators or service manual for exact specifications for your unit.

MAINTENANCE

LUBRICATION RECOMMENDATIONS

Description	Application	General Specification	Recommended Mobil Lubricant
Tractor Hydraulics	Reservoir	JD-20C MF M1135,M1141 FNHM2C134D (FNH201)	Mobilfluid 424
Mower Hydraulics	Reservoir		
Cold Temperatures 0 F Start-Up		ISO 46 Anti-Wear - Low Temp	Mobil DTE 15M
Normal Temperatures 10 F Start-Up		JD-20C MF M1135,M1141 FNH M2C134D (FNH201)	Mobilfluid 424
Normal Temperatures 15 F Start-Up		ISO 46 Anti-Wear	Mobil DTE 25
High Operating Temp. Above 90 F		ISO 100 Anti-Wear	Mobil DTE 18M
Flail Rear Gearbox	Grease	PAO Synthetic Extreme Pressure Gear Lube	Mobil SHC 75W-90 Mobil 1 Synthetic Gear
Cutter Shaft & Ground	Grease	Lithium-Complex	Mobilgrease CM-S
Roller Shaft (Flail)	Gun	Extreme Pressure NLGI 2 - ISO 320	
Drive Shaft Coupler (Flail and Rotary)	Grease Gun	Lithium-Complex Extreme Pressure NLGI2 - ISO 320	Mobilgrease CM-S
Boom Swivel	Grease	Lithium-Complex	Mobilgrease CM-S
Boom Cylinder Pivots (Rotary & Flail Boom)	Gun	Extreme pressure NLGI2 - ISO 320	
Deck Boom Pivot & Deck Stop Adjustment (Rotary & Flail)	Grease Gun	Lithium-Complex Extreme pressure NLGI 2 - ISO 320	Mobilgrease CM-S
Deck Spindle (Rotary)	Grease Gun	Tiger Spindle Lubricant part number 06540000	Mobilith SHC 220

MAINTENANCE

POLYCARBONATE CARE & MAINTENANCE

The proprietary UV and Abrasion Resistant surface coating on SHIELDS® SUPERCOATED™ polycarbonate significantly improves performance. Periodic cleaning using proper procedures and compatible cleaners are recommended to prolong service life. Tiger Corp. polycarbonate is SUPERCOATED™ on both sides.

CLEANING THE SUPERCOAT™ HARD-COAT

1. Wash with a mild solution of soap or detergent and lukewarm water.
2. Using a soft cloth or sponge, gently wash the sheet to loosen dirt and grime and rinse well with clean water.
3. To prevent water spotting, thoroughly dry with chamois or cellulose sponge.
4. Avoid the use of abrasive cleaners, squeegees and/or other cleaning implements that may mar or gouge the coating.

CLEANING AGENTS WHICH HAVE BEEN FOUND TO BE COMPATIBLE UNDER LABORATORY CONDITIONS:

- Aqueous Solutions of Soaps and Detergents
Windex¹ Top Job² Joy² Mr. Clean²
Fantastik³ Formula 409⁴ Sumalight D12 Brucodecid
- Organic Solvents
Butyl Cellosolve Kerosene Hexel, F.O. 554 Naphtha (VM&P grade)
Neleco-Placer Turco 5042
- Alcohols
Methanol Isopropyl

All residual organic solvents should be removed with a secondary rinse.

GRAFFITI REMOVAL

Butyl cellosolve (for removal of paints, marking pen inks, lipstick, etc.). The use of masking tape, adhesive tape or lint removal tools works well for lifting off old weathered paints.

To remove labels, stickers, etc., the use of kerosene or VM&P naphtha are generally effective. When the solvent will not penetrate sticker material, apply heat (hair dryer) to soften the adhesive and promote removal.

IMPORTANT: If a material is found to be incompatible in a short-term test, it will usually be found to be incompatible in the field. The converse, however, is not always true. Favorable performance is no guarantee that actual end-use conditions have been duplicated. Therefore, these results should be used as a guide only and it is recommended that the user test the products under actual end-use conditions.

MAINTENANCE

RECOMMENDED FILLING INSTRUCTIONS FOR HYDRAULIC RESERVOIRS

When filling or checking the oil level, the unit should be parked on a level surface, shut "OFF", and allowed sufficient time to cool to ambient temperature. Use caution when removing the pressurized breather. Do not place face over opening when removing the breather.

The reservoir should be filled to the top of the lower sight glass on the side of the tank. Do not over-fill. The reservoir has been over-filled when oil is visible in the upper sight glass. If tank has too much oil, the excess may be expelled through the pressurized breather.

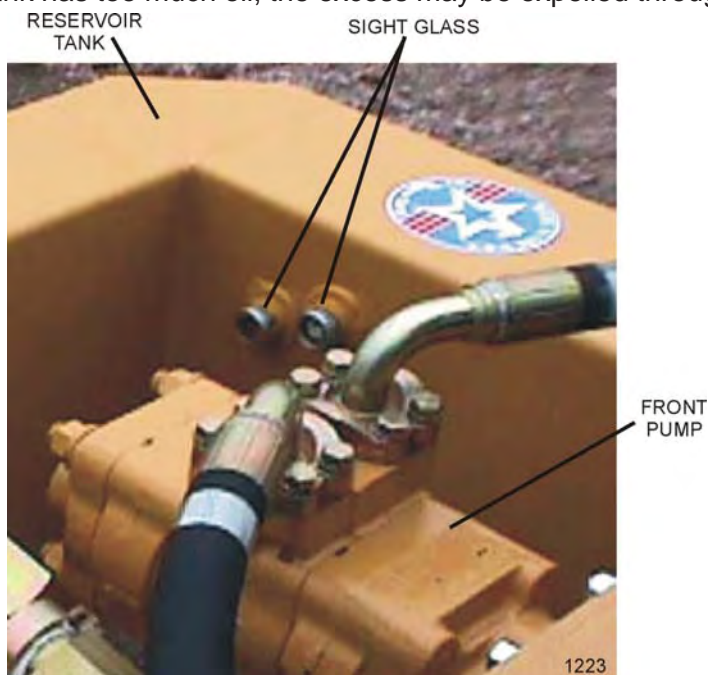

DETAILED MAINTENANCE

REPLACING IN-TANK HYDRAULIC FILTER:

Loosen the four bolts on the top cover of the filter housing. Turn cover counter-clockwise until cover is free. Remove and replace filter. Replace top cover and cover bolts in opposite order as removed.

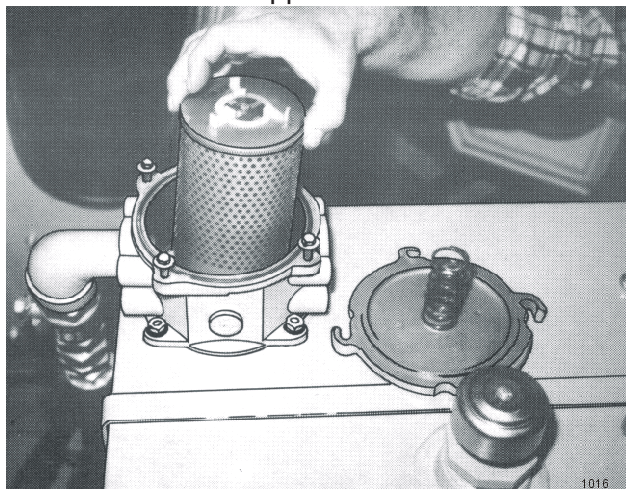

MAINTENANCE

DETAILED MAINTENANCE

REPLACING HIGH PRESSURE HYDRAULIC FILTER ELEMENT:

Assure system has been shut down and de-pressurized. Locate High Pressure Filter housing. Confirm that the element that is about to be installed matches the element p/n on the filter model tag. Example: V3.0510-06 (world line 100, HD049 model) Locate the bottom of the High Pressure Bowl, and use the appropriate spanner wrench –or- ratchet that matches the hex pattern. Using the spanner wrench -or- ratchet and turning in a counterclockwise rotation, (looking at the bottom of the bowl) remove the bowl from the head, The first couple rotations will seam tight as the o-ring passes the sealing flats, once the o-ring has cleared the sealing flats the bowl should spin freely. Taking care not to drop the bowl, finish removing the bowl from the head. **WARNING:** bowl will be full of oil! Pour the oil from the bowl into a container, this oil should be considered contaminated due to the flow direction through the element is outside ~ in. Clean the inside of the bowl if “dirt” is present. Remove the old element from the filter head by pulling with a rotation motion. Dispose of the used element properly. Remove the new element from the packaging. Using your finger, dab and lubricate the o-ring in the top of the new element. Install the new element into and on the mounting boss with in the head; assure that the element is fully seated on the boss. Clean and inspect the o-ring that is affixed in the bowl, lubricate with oil. Using a clockwise rotation, screw the bowl back into the head, assuring that the bowl has not been cross threaded into the head. Continue “tighten” the bowl into the head, using the spanner wrench –or- ratchet, the rotation of the bowl will become tighter once the o-ring engages the sealing flats. Once the bowl has been fully inserted into the head, and the o-ring has reached the sealing flats, the bowl can no longer be “tightened” and bottoms out. Once the bowl has bottomed out, “back-off” the bowl by 1/6 turn, this assures that the o-ring is seated properly with in the sealing flats. Element change out and re-assembly is now complete. Start the machine and inspect the filter area checking that there is no oil leaking from the filter assembly. This is first to be done at 50 hours of operation, then yearly(500 hours) or when indicated by restriction indicator.

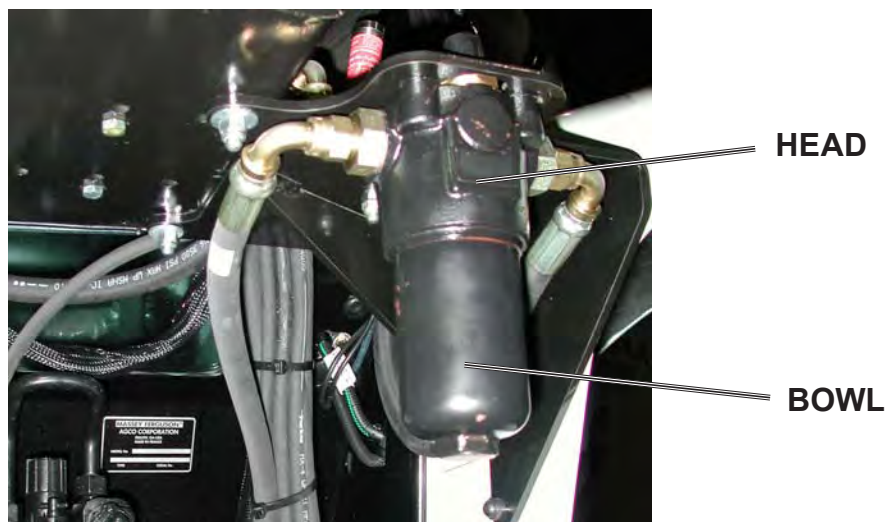

MAINTENANCE

GREASING INNER AND OUTER DRAFT BEAM PIVOT POINTS

Locate the grease zerks on the inner and outer draft beam pivot bosses. Inject Lithium-Complex Extreme Pressure grease conforming to NLGI2-ISO 320 specifications into each zerk until grease protrudes from joints. Grease all pivots daily or every 8 hours of service.

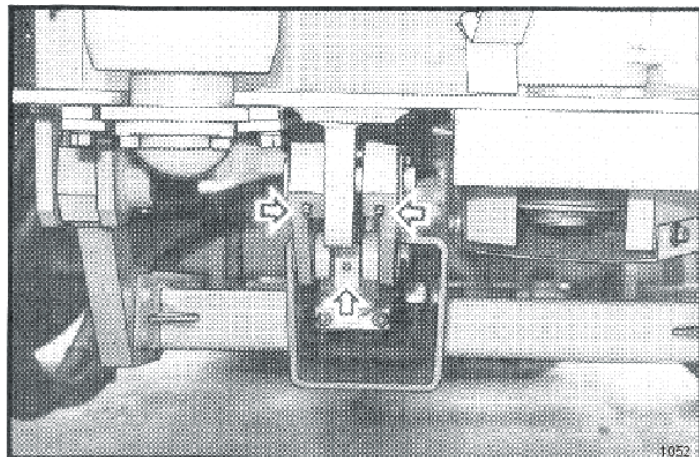
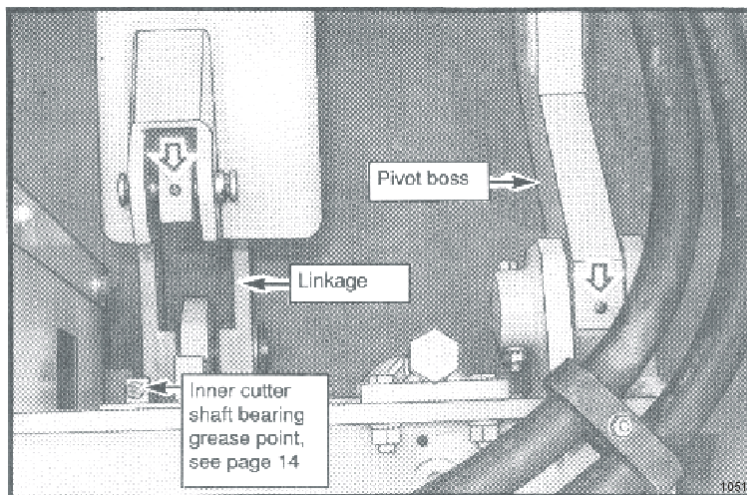
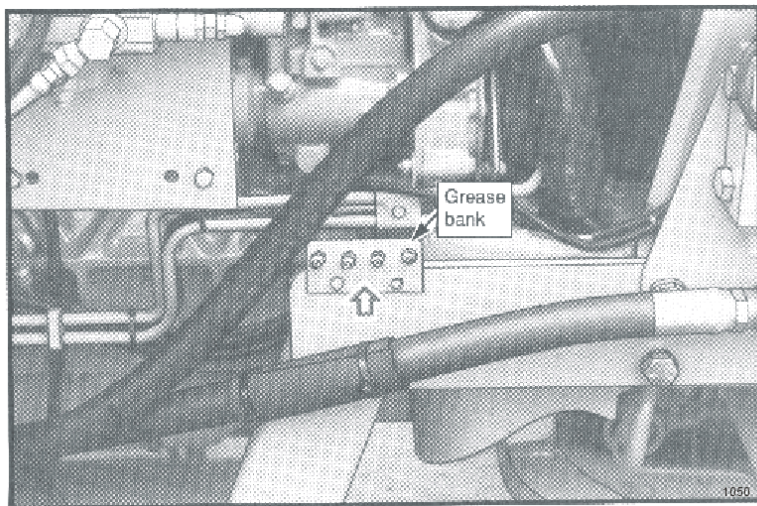

With the cutter head lowered, locate the grease zerks on the linkage and pivot bosses. Inject Lithium-Complex Extreme Pressure grease conforming to NLGI2-ISO 320 specifications until it protrudes from the ends. With the cutter head in this position it is also possible to grease the draft beam cylinder anchors and pins. Now raise the cutter head to expose the remaining zerks on the deck tilt linkages and on the other end of the cylinder.

MAINTENANCE

GREASING THE REAR DRIVE BEARING AND EXTENSION COUPLER SHAFT

Locate the grease zerks for the rear flail drive extension shaft. Make sure the zerks are clean before injecting grease. One pump of grease into flange zerk and shaft coupler once every day or for every 8 hours of service.

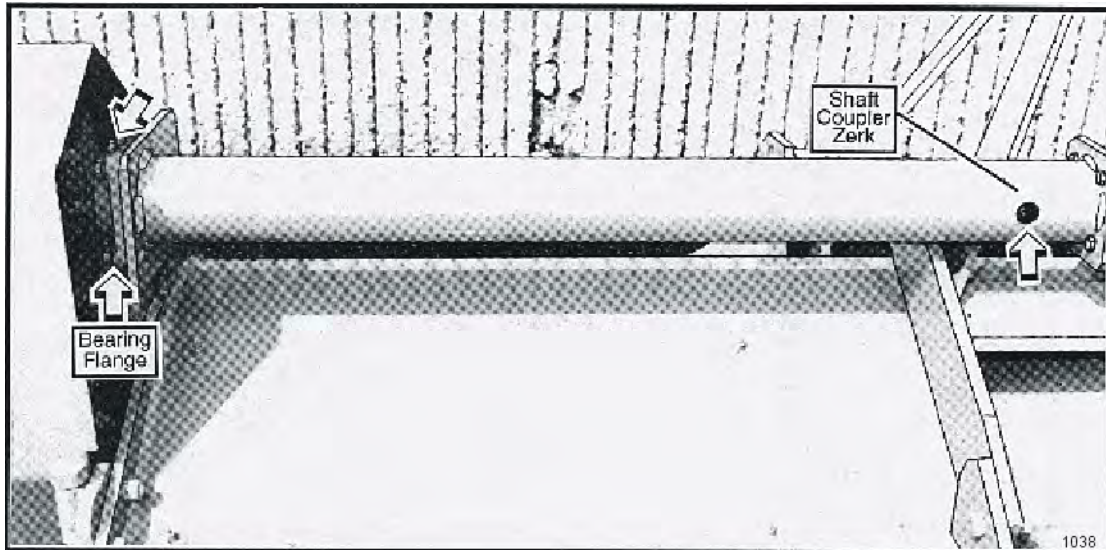

GREASING PUMP DRIVE SHAFT COUPLER

With engine stopped, ensure drive shaft alignment by grasping coupler and sliding back and forth. Coupler should slide freely with approximately 1/8" of end play. If coupler does not slide freely, inspect for loose pump mount bolts, or damaged or loose crank shaft adapter. Inject Lithium-Complex Extreme Pressure grease conforming to NLG12-ISO 320 specifications into coupler until grease begins to protrude from ends. Grease daily or every 10 hours. Do not over grease.

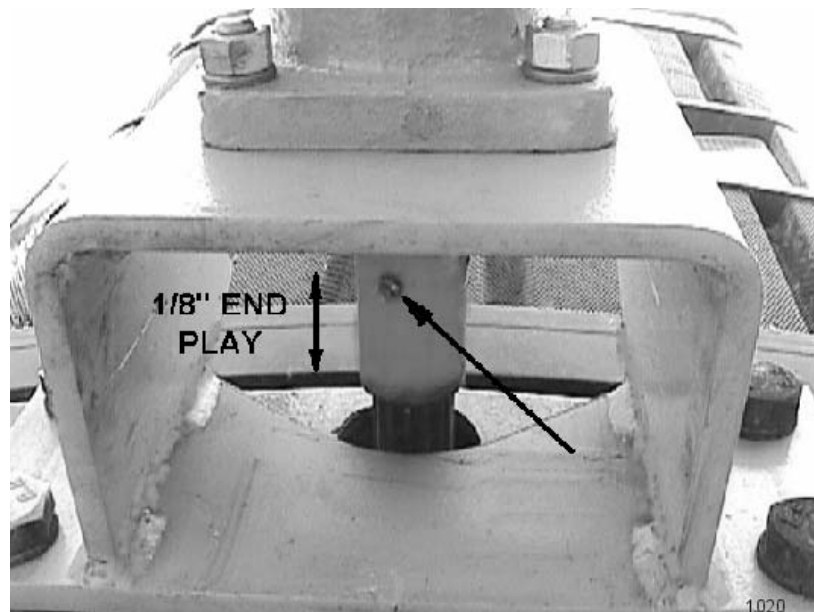

MAINTENANCE

ADJUSTING THE CUTTING HEIGHT

Loosen the four ground roller bracket lock nuts. Loosen the adjustment rod lock nut and turn the adjustment rod to adjust the cutting height. The cutting height is indicated by the end of the adjustment rod on the cutting height decal. When cutting height has been achieved, tighten the ground roller bracket lock nuts and the adjustment rod lock nut securely. Be sure both sides of the flail are adjusted the same.

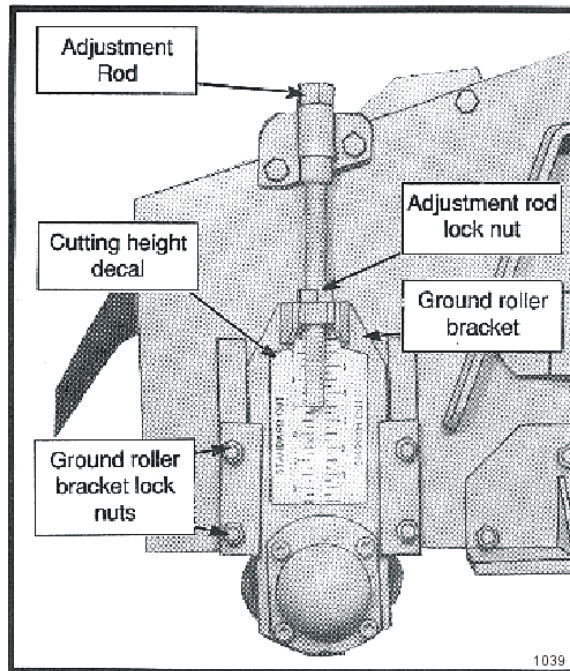

ADJUSTING STANDARD DUTY CUT HEIGHT

To adjust the cutting height of the standard duty flail head the two nuts on the roller shaft brackets must be taken off and moved to the desired location / height. See diagram below. Be sure that both sides of the shaft are adjusted to corresponding holes so the shaft remains level.

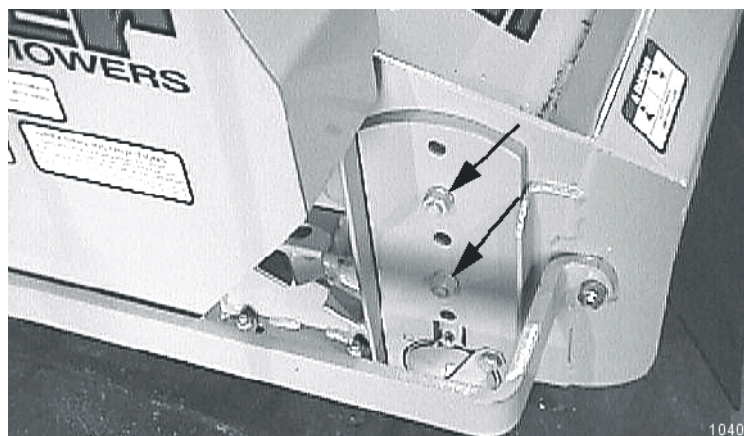

MAINTENANCE

GREASING P.T.O. SHAFTS

After bringing the tractor to a complete stop, shut off the engine and remove the P.T.O. shaft from the tractor. Slide the shaft apart to expose the grease zerk. Grease the shaft with 5 pumps of grease and the U-joints until grease protrudes from caps per the scheduled interval in the maintenance section.

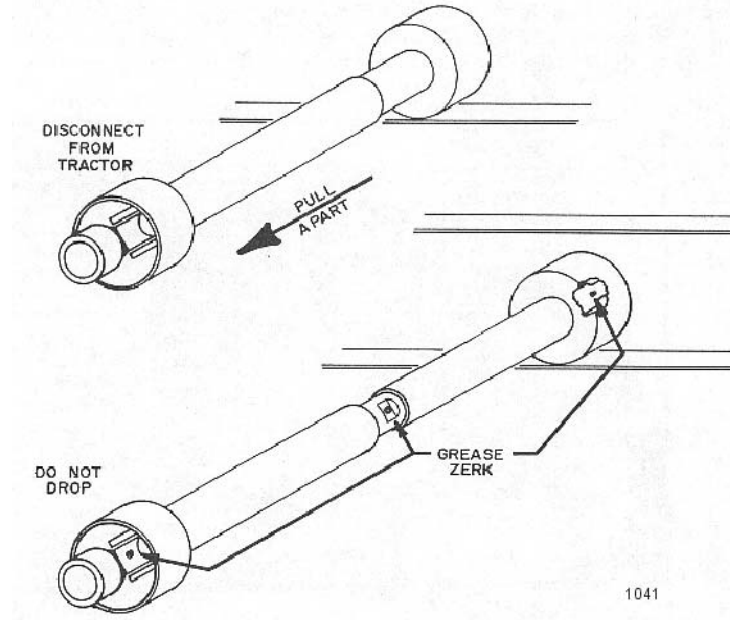

BALL VALVES

The ball valves at the hydraulic reservoir may need to be closed during certain maintenance or repair procedures. **THE BALL VALVES MUST BE OPEN (handle parallel with valve) WHEN TRACTOR IS RE-STARTED OR PUMP IS COUPLED TO MOTOR OR P.T.O. !** Failure to do so may result in component failure!



MAINTENANCE

GREASING CUTTER SHAFT – FLAIL MOWERS

Locate grease zerks on each end of cutter shaft(s), these are located on the bearing cover. Normal conditions require one or two pump in each bearing, using Lithium-Complex Extreme Pressure grease conforming to NLGI2-ISO 320 specifications. This is to be done with a standard grease gun daily or at **8 hour intervals**. **CAUTION: Over greasing may cause premature seal failure.**

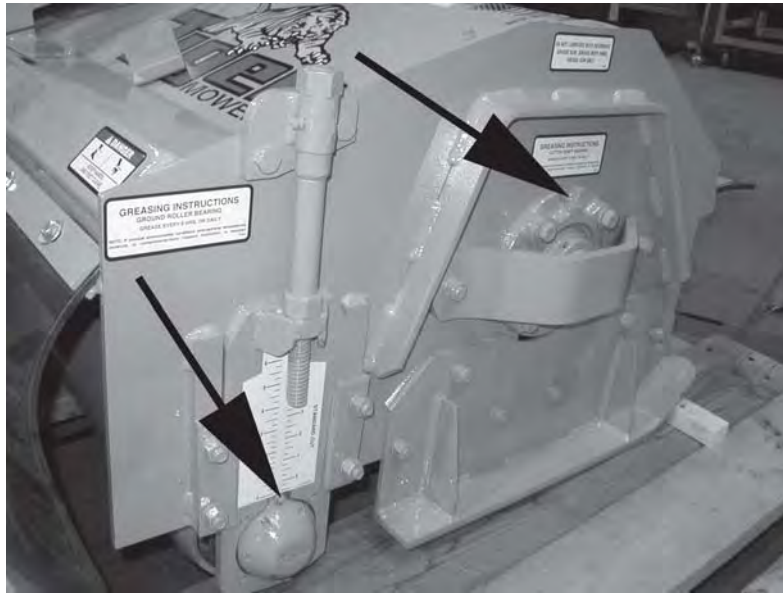

GREASING GROUND ROLLER SHAFT – FLAIL

Locate grease zerks on each end of roller tube at lower rear of head. Normal conditions require one or two pump in each bearing, using Lithium-Complex Extreme Pressure grease conforming to NLGI2-ISO 320 specifications. This is to be done with a standard grease gun daily or at **8 hour intervals**. **CAUTION: Over greasing may cause premature seal failure.**

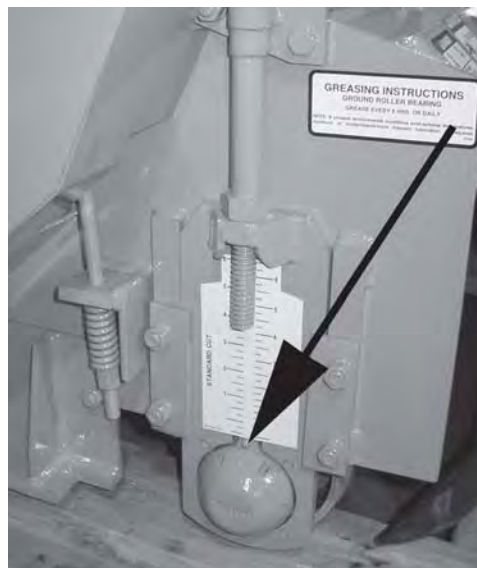

MAINTENANCE

GREASING THE IDLER TENSION ARMS

Locate the access holes and grease zerks in the belt shields of the side and rear flails. Normal conditions require one pump daily or every 8 hours of service with multi purpose grease.

IDLER TENSIONING

Locate the idler tensioning rod for each flail. Loosen the locking nut. Turn the adjusting nut until the washer in between the spring and nuts is flush with the spring housing or guide. Tighten locking nut securely. For standard cut on side flail adjust until the spring washer is flush with the top of the spring housing, as shown below. Use this same method to adjust hydraulically driven rear flails.

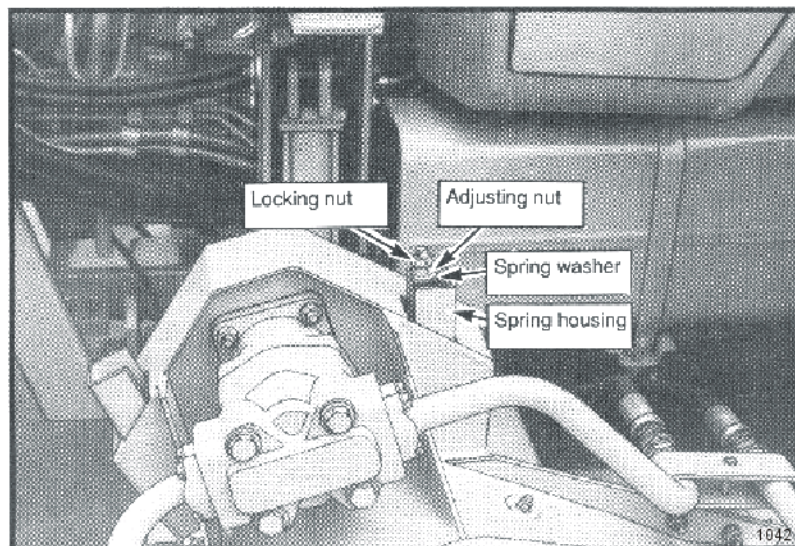

For standard cut on the mechanically driven rear flail mower, adjust so that the spring washer is flush with the spring guide as shown below.

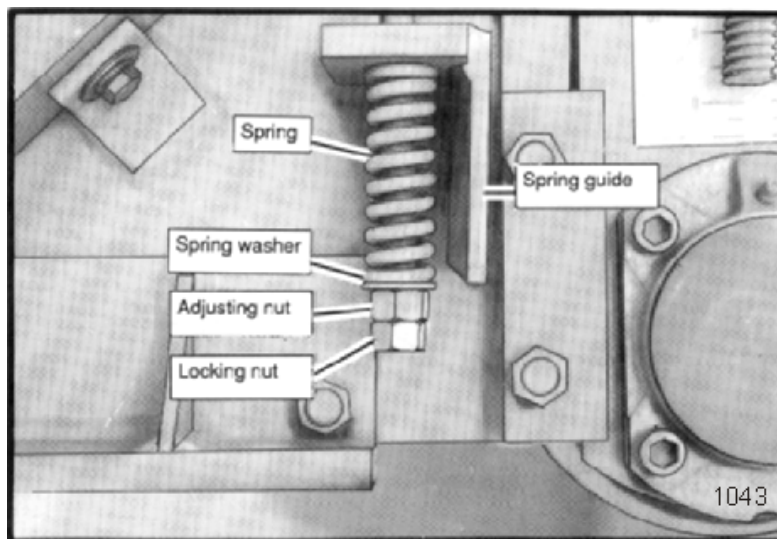

MAINTENANCE

ROSTA TENSIONER - STD DTY REAR FLAILS

Remove the guard over the belt shield. Then remove the belt shield that covers the tensioner, belt and sheaves.



BELT SHIELD

CUTTERSHAFT
GUARD

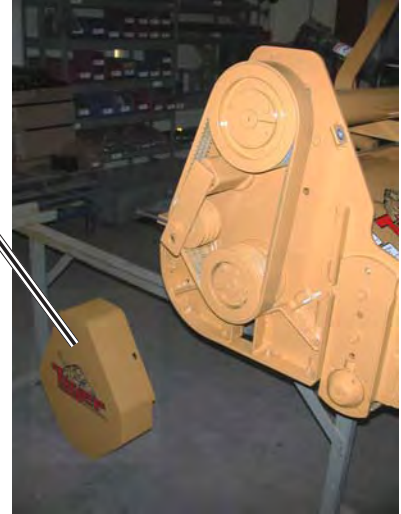

Place a straight edge over both sheaves and measure the belt tension (See TENSIONER MEASUREMENT PROCEDURE). To adjust the Rosta Tensioner, first, loosen the Rosta Stop and Rosta bolt that secures the Rosta to the flail. Next use the Wrench (PN# 06401023 available) to adjust the tension of the belt. After the tension has been set, secure the Rosta Stop and re-torque the Rosta Bolt to specs.

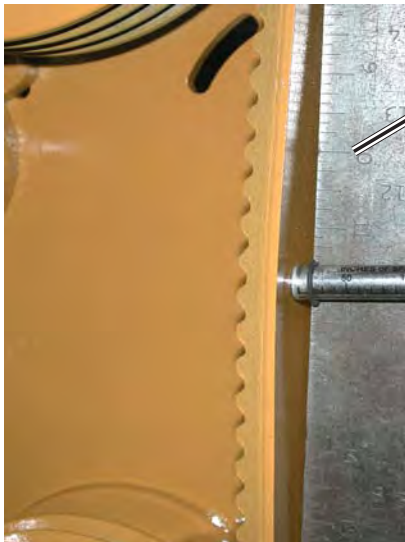

STRAIGHT EDGE

ROSTA STOP

ROSTA WRENCH

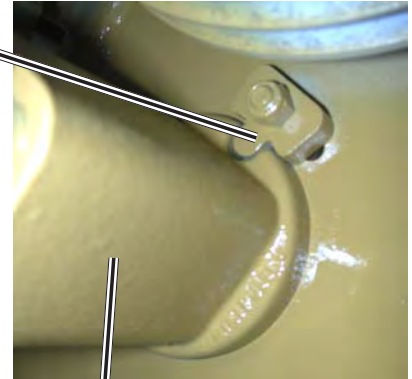

ROSTA
ARM

MAINTENANCE

TENSIONER MEASUREMENT PROCEDURE

1. Measure the Belt Span (SEE SKETCH).
2. Position the bottom of the Large "O" Ring on the Span Scale at the measured Belt Span.
3. Set the Small "O" Ring on the Deflection Force Scale to zero.
4. Place the tension gauge squarely on the belt at the center of the belt span. Apply a force on the plunger perpendicular to the belt span until the bottom of the Large "O" Ring is even with the bottom of a straight edge laid across the sheaves.
5. Remove the tension gauge and read the force applied from the bottom of the Small "O" Ring on the Deflection Force Scale.
6. Compare the force denoted by the Small "O" Ring with the values shown. The force should be between the values given for either a New Belt or Used Belt.
7. Make sure to use the force values in pounds if the span is measured in inches. Use kilograms of force if the span is measured in centimeters.
8. NOTE: The ratio of the deflection to belt span is 1/64 in either units of measurements.

Deflection Force Values - Standard Duty

New Belt: 20 to 25 pounds

Used Belt: 12 to 20 pounds

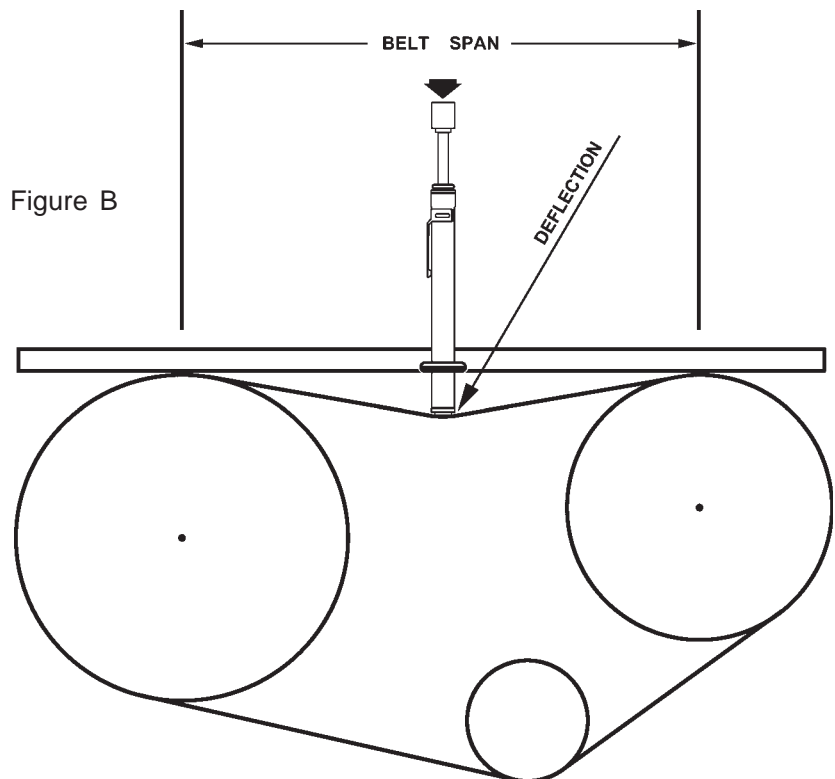
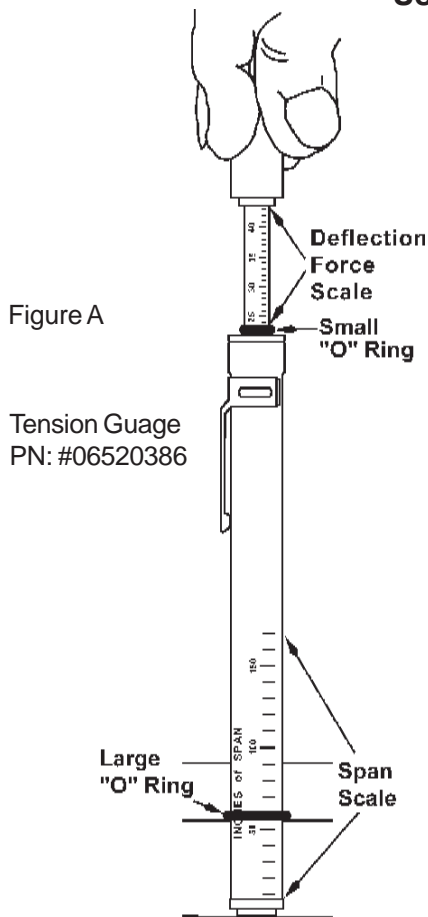

MAINTENANCE

REVERSING MOWER ROTATION OF SIDE AND REAR HYDRAULIC FLAIL MOWERS

To reverse the rotation of the side and hydraulically driven rear flail, a different idler arm is needed only for side flail. Part No. TF4346 is used in standard rotation. Part No. TF4345 is used in reverse rotation.

When before attempting this procedure be sure all dirt is cleaned away from the motor and around all hose connections. This is to prevent the oil from becoming contaminated. 1-Start by removing the belt shield from the flail mower. 2-Remove the locking and adjusting nut, spring washer and spring from the idler tensioning rod. 3-Disconnect the tensioning rod from the idler arm. 4-Remove the idler arm with the idler pulley attached. 5-Remove the idler pulley from the idler arm and reinstall on the short end of the new idler arm.

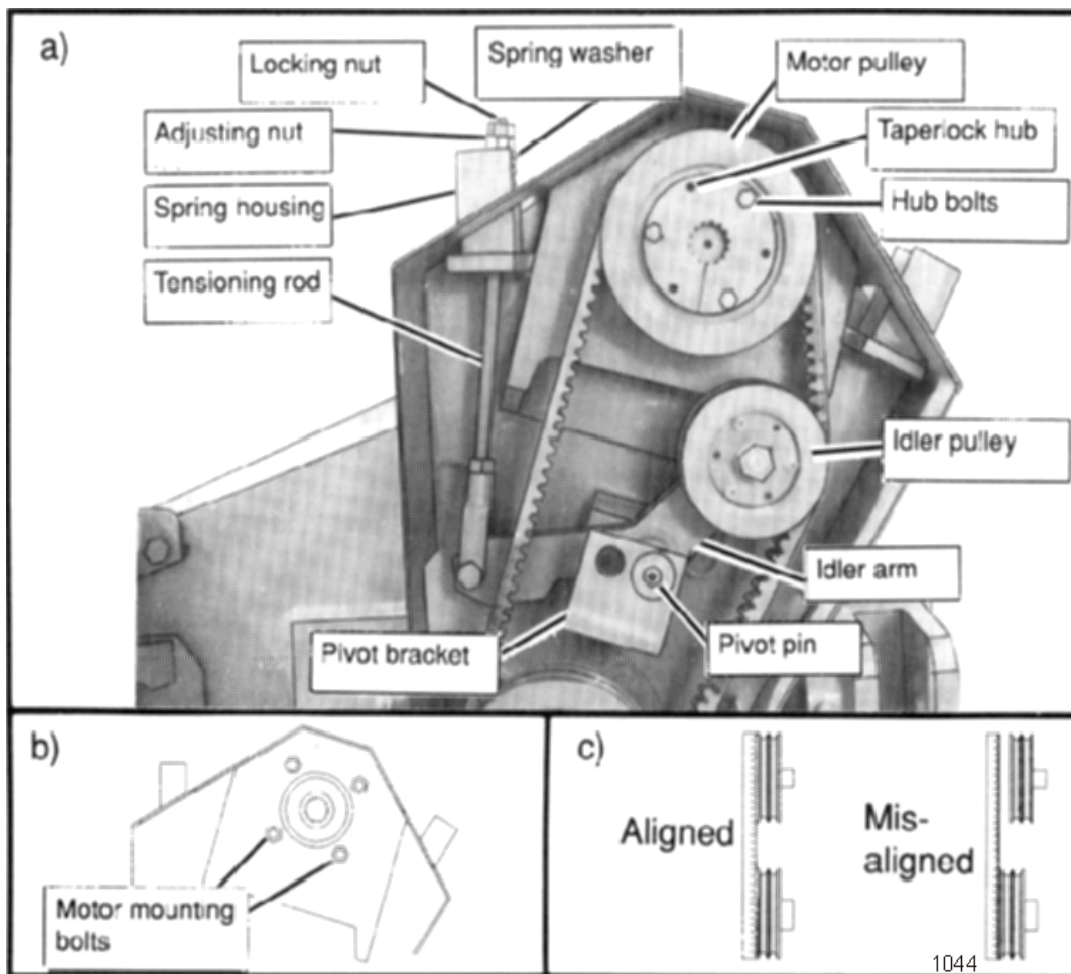

Reinstall the idler arm and pivot pin. The pivot pin is installed into the hole in the pivot bracket closest to the idler pulley. When assembling for **standard** cut rotation, the idler arm is installed with the idler pulley toward the front of the mower with the pivot pin in the front hole. When assembling for **reverse** rotation, with smooth cut knives, the idler arm is installed with the idler pulley toward the rear of the mower with the pivot pin in the rear hole.

(continued on next page)

MAINTENANCE

Now disconnect the hoses and fittings from the motor and remove the taper-lock hub and pulley from the motor by removing the three hub bolts from the existing positions and inserting simultaneously into the threaded holes. Remove the four bolts holding the motor. Rotate the motor 180° so the hump is opposite the prior position. Reinstall the motor bolts and torque to 75 ft. lbs. Reconnect the hoses and fittings to the motor in the same configuration as before, i.e. the hose that was connected to the front port on the motor should now be connected to the port that is now facing the front.

Reinstall the taper-lock hub and pulley on the motor by installing the hub bolts in the original holes and tightening until the hub just contacts the pulley. Then, position the pulley on the motor shaft approximately 3/16" beyond the idler pulley and tighten and torque the hub bolts to 18 ft. lbs. Be sure the pulleys are vertically aligned when tight (see diagram on previous page) , loosen and readjust if needed.

Reinstall the belts and idler tensioning rod. Tighten and lock the tensioning rod as shown previously in the maintenance section. Reinstall the belt shield.

With the motor rotation changed, now all of the knives on the cutter shaft must be changed as required. The cutter shaft rotates in the same direction as the tractor tires when going forward for standard cut knives. The shaft rotates opposite to standard rotation for smooth cut knives. Smooth cut knives should be installed so the cutting edge is forward.

When operating in standard rotation, the front shield must be removed and the baffle installed. When operating in reverse rotation, remove the baffle and install the front shield. Finally, reposition the wear pads on the hoses and replace the zip ties as needed to prevent the hydraulic hoses from rubbing or chafing.

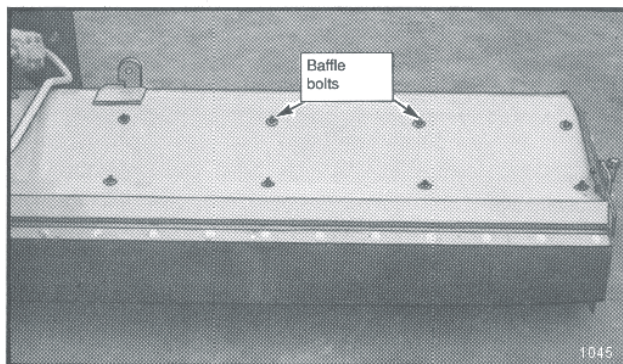
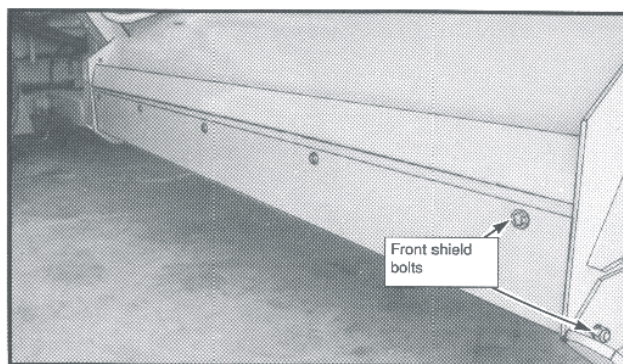

MAINTENANCE

REVERSING MOWER ROTATION REAR MECHANICAL DRIVEN FLAIL MOWERS

Remove the rear shaft guard and disconnect the chain coupling to the shaft. Disconnect the P.T.O. drive shaft from the right angle gear box. Remove the gear box from the flail frame and lay down flat so that gear oil does not leak out.

Switch the top breather vent plug with the drain plug on the bottom. Remove the input shaft guard. The input shaft must be pressed through or turned around so the rear extension is equal to what the original front dimension was. Turn the gear box 180° and install on the flail frame so the chain coupling sprockets are side by side and the breather vent plug is on the top of the case.

The sprockets must be aligned and spaced approximately 3/8" apart. When changing from standard cut to smooth cut rotation, a spacer plate may have to be installed between the gear box and the frame. When changing from smooth cut to standard cut rotation the spacer plate is to be omitted. Install the chain for the chain coupling. If there is any binding, or no free movement in the chain, the bearing next to the coupler may be shimmed as required to eliminate the chain binding.

Change all the knives on the cutter shaft as required. The cutter shaft rotates in the same direction as the tractor tires when going forward for standard knives. The cutter shaft rotates opposite the tractor tires for smooth cut knives.

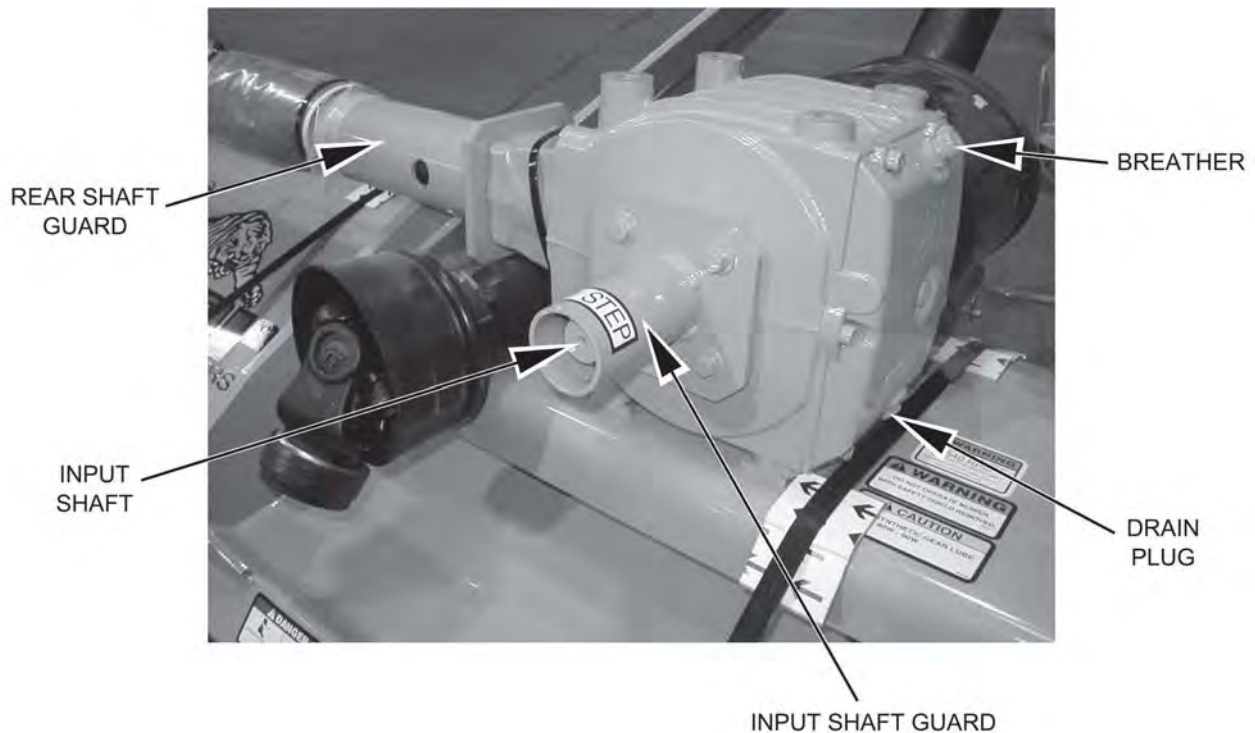

(continued on next page)

MAINTENANCE

Remove the belt shield. Then remove the adjusting nuts, washer and spring from the idler tensioning rod. Remove the clevis rod and small bushing from the idler arm. Remove the idler arm with the pulley attached. Remove the idler pulley from the idler arm and install the pulley on the other end of the idler arm. Reinstall the idler arm in the pivot bracket. For standard cut rotation the pulley is toward the front, for reverse rotation with smooth knives, the idler pulley is toward the rear. Install the small bushing in the idler arm and connect the idler tensioning rod.

Tighten the adjusting nuts for the idler arm tensioner as shown previously in the maintenance section. Install the belt shield, the shaft guard and P.T.O. shaft guards.

When operating the mower in reverse rotation with smooth cut knives, remove the baffle and install the front shield. When operating the mower in standard rotation with standard cut knives, remove the front shield and install the baffle.

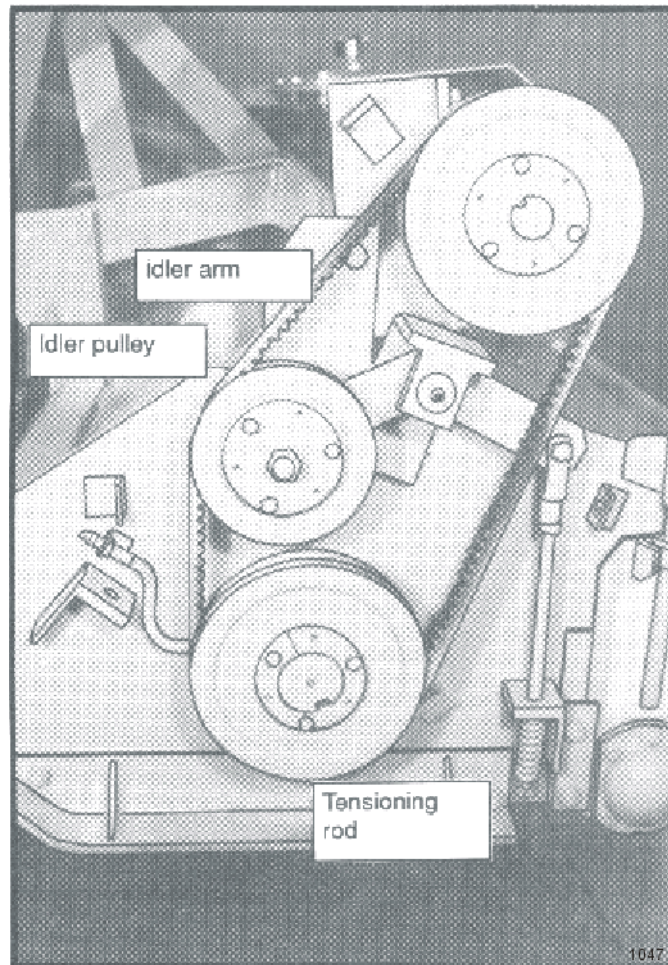

MAINTENANCE

STANDARD OR HEAVY DUTY SIDE OR REAR FLAIL KNIFE REPLACEMENT

- 1 – If knives are damaged or badly worn, they will need to be replaced as a set. Replacing a single knife can cause severe vibration and possible damage to the mower.
- 2 – Assemble knives, bushings, collars, bolts and nuts as shown in part section of manual.
- 3 – Install locking hex nut so that the flat face of nut is towards the knife.
- 4 – Torque nut to 35 FT. LBS. Knife must swing freely.

WARNING!



DO NOT re-use the locking hex nuts for mounting the knives. If hex nut become loose, or require removal for knife replacement or any other reason, they must be discarded and replaced with new nuts.

WARNING!



Knives should not be welded on for any reason.

MAINTENANCE

RECOMMENDED FILLING INSTRUCTIONS FOR REAR FLAIL GEAR BOX

When filling or checking the fluid level, the unit should be parked on a level surface with rear flail down on surface, shut “**OFF**”, and cold, (at ambient temperature).

Remove the fluid level plug located on the side of the gear box. The gear box should be filled to the bottom of the fluid level hole. If necessary, use 75 - 90 wt. PAO Synthetic Extreme Pressure Gear Lube to raise level to bottom of the hole.

Do not over-fill. excessive gear oil will run back out of the hole. Reinstall fluid level plug into gear box. If gear box has been over-filled, the excess may be expelled through the pressurized breather.

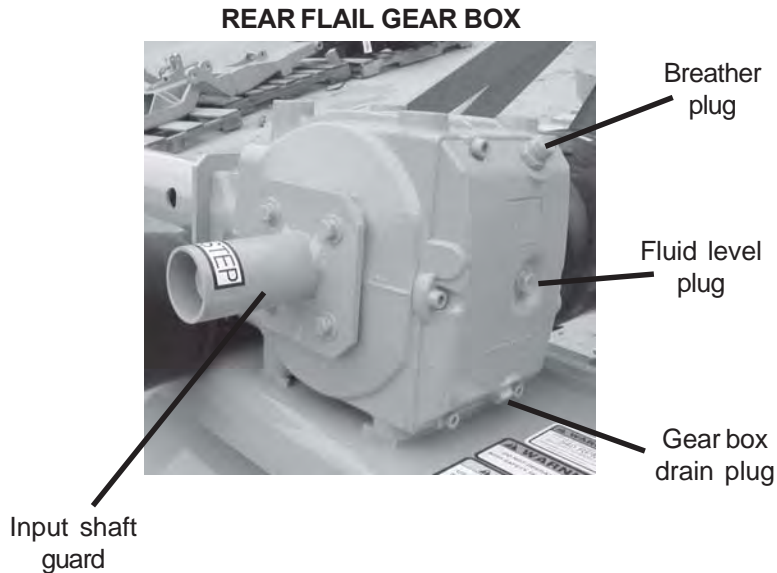

MAINTENANCE

DAILY MAINTENANCE SCHEDULE

The following services should be performed **daily** or every **8 hours** of service, following the detailed maintenance instructions in the operators manual.

_____ Pump Drive Shaft: Check for end play in drive shaft / coupler and lubricate at zerks.

_____ Crankshaft adapter: If equipped with rubber grommets check condition, replace if missing or damaged.

_____ Pivot points: Inject grease until it appears at ends.

_____ Hydraulic fittings: Check for leaks with paper or cardboard. Tighten fittings or replace hoses immediately.

_____ Knives: Inspect for missing or damaged knives, change (only complete sets) as needed.

_____ Belts: Check / Tighten / Replace belts as needed.

_____ Main Frame / Deck: Unless otherwise specified retorque bolts according to torque specifications in this section.

_____ Hydraulic Fluid Level: Add, if required, per fluid recommendations.

_____ Rear Flail Drive, Bearing
Flange and Shaft Couplers: Grease as instructed in the detailed (if applicable) maintenance section.

_____ Cutter Shaft and Ground Roller: Grease as instructed in the detailed maintenance section

Service performed by: _____ Date: ____/____/____ Hour
Meter: _____

Maintenance Section

** This page may be copied and used as part of the daily maintenance routine.

JD 5525 / 5093-5101E TRIPLE FLAIL, CAB

**PARTS
SECTION**

PARTS ORDERING GUIDE

The following instructions are offered to help eliminate needless delay and error in processing purchase orders for the equipment in this manual.

1. The Parts Section is prepared in logical sequence and grouping of parts that belong to the basic machine featured in this manual. Part Numbers and Descriptions are given to help locate the parts and quantities required.

2. The Purchase Order must indicate the **Name and Address** of the person or organization ordering the parts, **who should be charged**, and if possible, the **serial number of the machine** for which the parts are being ordered.

3. The purchase order must clearly list the **quantity of each part**, the complete and correct **part number**, and the basic **name of the part**.

4. The manufacturer reserves the right to substitute parts where applicable.

5. Some parts may be unlisted items which are special production items not normally stocked and are subject to special handling. Request a quotation for such parts before sending a purchase order.

6. The manufacturer reserves the right to change prices without prior notice.

NOTE: When ordering replacement decals, refer to the part numbers and descriptions listed in the safety section in the front of this manual.



1000

For maximum safety and to guarantee optimum product reliability, always use genuine **Tiger** replacement parts. The use of inferior replacement parts may cause premature or catastrophic failure which could result in serious injury or death.

Direct any questions regarding parts to:

Tiger Corporation
3301 N. Louise Ave.
Sioux Falls, SD 57107
1-800-843-6849
1-605-336-7900

PARTS SECTION TABLE OF CONTENTS

SECTION	PAGE
TRACTOR SPECIFIC PARTS:	
TRAC. MT. KIT – MAIN FRAME, 5525-CAB	5-4
TRACTOR MOUNT KIT – FUEL TANK CAB	5-6
TRACTOR MOUNT KIT – HYDRAULICS	5-8
LIFT VALVE - 4SP CAB 5525	5-10
LIFT VALVE - 4SP CAB 5093-5101E	5-12
4SP HUSCO – BREAKDOWN	5-14
DRAFT BEAM – RIGHT HAND	5-16
DRAFT BEAM – LEFT HAND	5-18
HYDRAULIC COOLER - CAB 5525	5-20
POLYCARBONATE SAFETY WINDOW	5-22
SOLENOID WIRING	5-23
EGRESS SYSTEM	5-25
COMMON PARTS SECTION	6-1

TRACTOR MOUNT KIT - MAIN FRAME, CAB, 5525

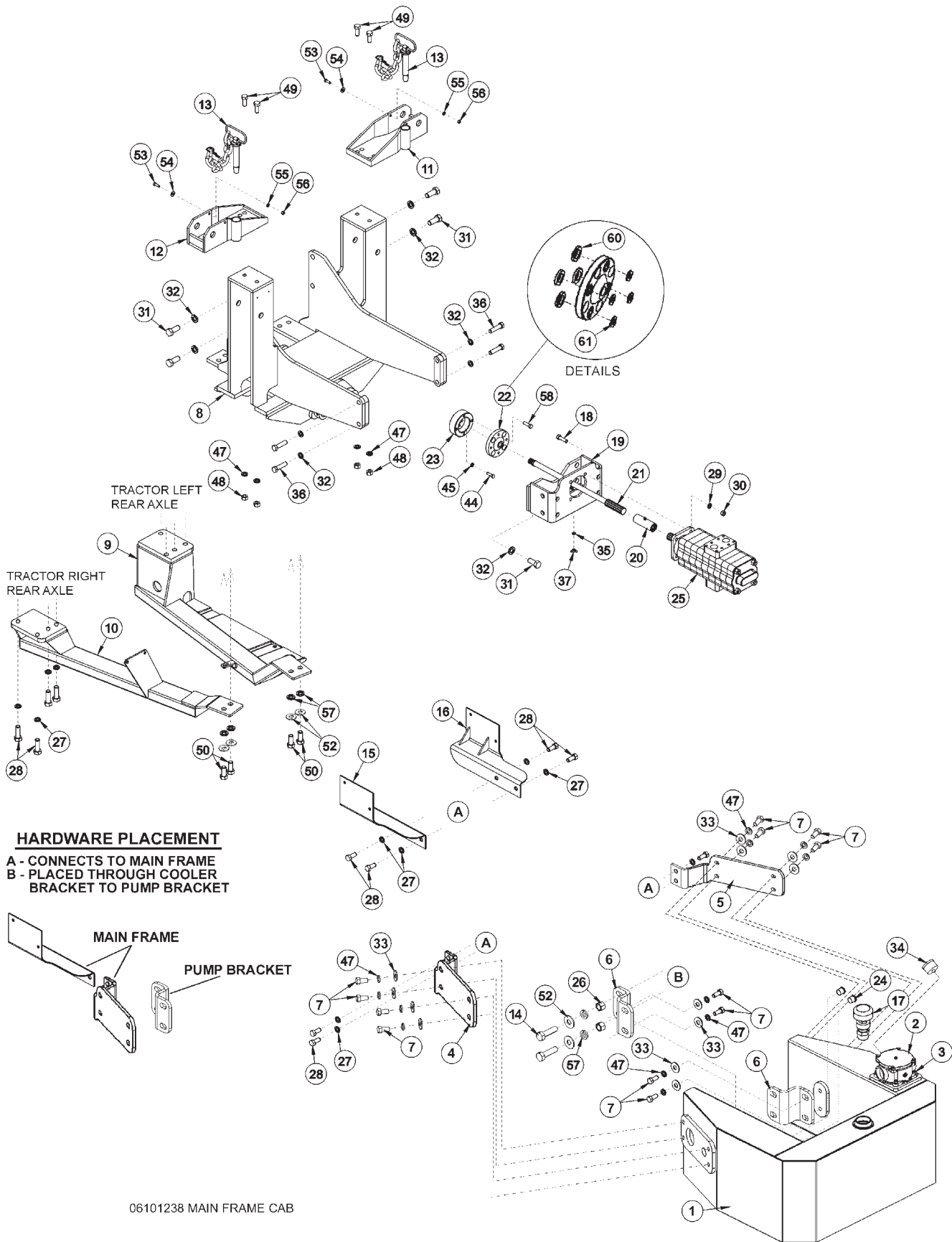

06101238 MAIN FRAME CAB

TRACTOR MOUNT KIT - MAIN FRAME, CAB, 5525

ITEM	PART NO.	QTY.	DESCRIPTION
1	34666	1	RESERVOIR TANK
2	35269	1	IN-TANK FILTER ASSY.
3	21627	4	NYLOCK NUTS
4	06410259	1	RIGHT HAND TANK BRACKET
5	06410258	1	LEFT HAND TANK BRACKET
6	06410150	2	SMALL MOUNT PLATE
7	21780	12	CAPSCREW, 5/8" X 1 1/4"
8	06300036	1	MAIN FRAME
9	06300038	1	AXLE BRACE LEFT HAND
10	06300037	1	AXLE BRACE RIGHT HAND
11	TF4253LA	1	TRAVEL LOCK BRACKET LH
12	TF4253RA	1	TRAVEL LOCK BRACKET RH
13	TF4250	2	TRAVEL LOCK PIN W/ CHAIN
14	21835	4	CAPSCREW, 3/4" X 2-3/4" NC
15	32323	1	SOLENOID BRACKET - RH
16	32324	1	SOLENOID BRACKET - LH
17	31004	1	PRESSURE CAP ASY.
18	21732	4	CAPSCREW 1/2" X 1 3/4"
19	32642	1	PUMP MOUNTING BRACKET
20	6T0375B	1	DRIVE SHAFT COUPLER
21	06520135	1	PUMP DRIVE SHAFT
22	6T0389	1	CRANKSHAFT ADAPTER
23	06400307	1	CRANKSHAFT SPACER
24	6T1209	2	TANK SIGHT GLASS
25	TF4450	1	HYDRAULIC PUMP
26	21825	4	HEX NUT , 3/4" NC
27	6T2625	8	LOCKWASHER,16MM
28	22421	8	CAPSCREW,16MMX40MM(2.0 PITCH)
29	21990	4	LOCKWASHER 1/2"
30	21725	4	HEX NUT 1/2"
31	24860	8	CAPSCREW,20MMX40MM(2.5 PITCH)
32	24881	12	LOCKWASHER,20MM
33	22020	12	FLATWASHER 5/8"
34	6T0649	1	FILTER GAUGE
35	22014	1	FLATWASHER 1/4"
36	25341	4	CAPSCREW 20MM X 70MM (2.5 PITCH)
37	32519	1	WING NUT 1/4"
44	6T2501	4	CAPSCREW 10MM X 60MM
45	32691	4	LOCKWASHER 10MM
47	21992	16	LOCKWASHER 5/8"
48	21775	4	HEX NUT 5/8"
49	21783	4	CAPSCREW,5/8 X 2 NC
50	21831	4	CAPSCREW 3/4" X 1 3/4"
52	22021	8	FLATWASHER 3/4"
53	21580	2	CAPSCREW 5/16" X 1"
54	22015	2	FLATWASHER 5/16"
55	21987	2	LOCKWASHER 5/16"
56	21575	2	HEX NUT 5/16"
57	21993	8	LOCKWASHER 3/4"
58	6T2260	4	CAPSCREW 7/16" X 1 1/2" CUT
60	06537004	4	WASHER,NEOPRENE,.75x1.25x.19
61	24937	4	FLATWASHER

TRACTOR MOUNT KIT - FUEL TANK, CAB, 5525

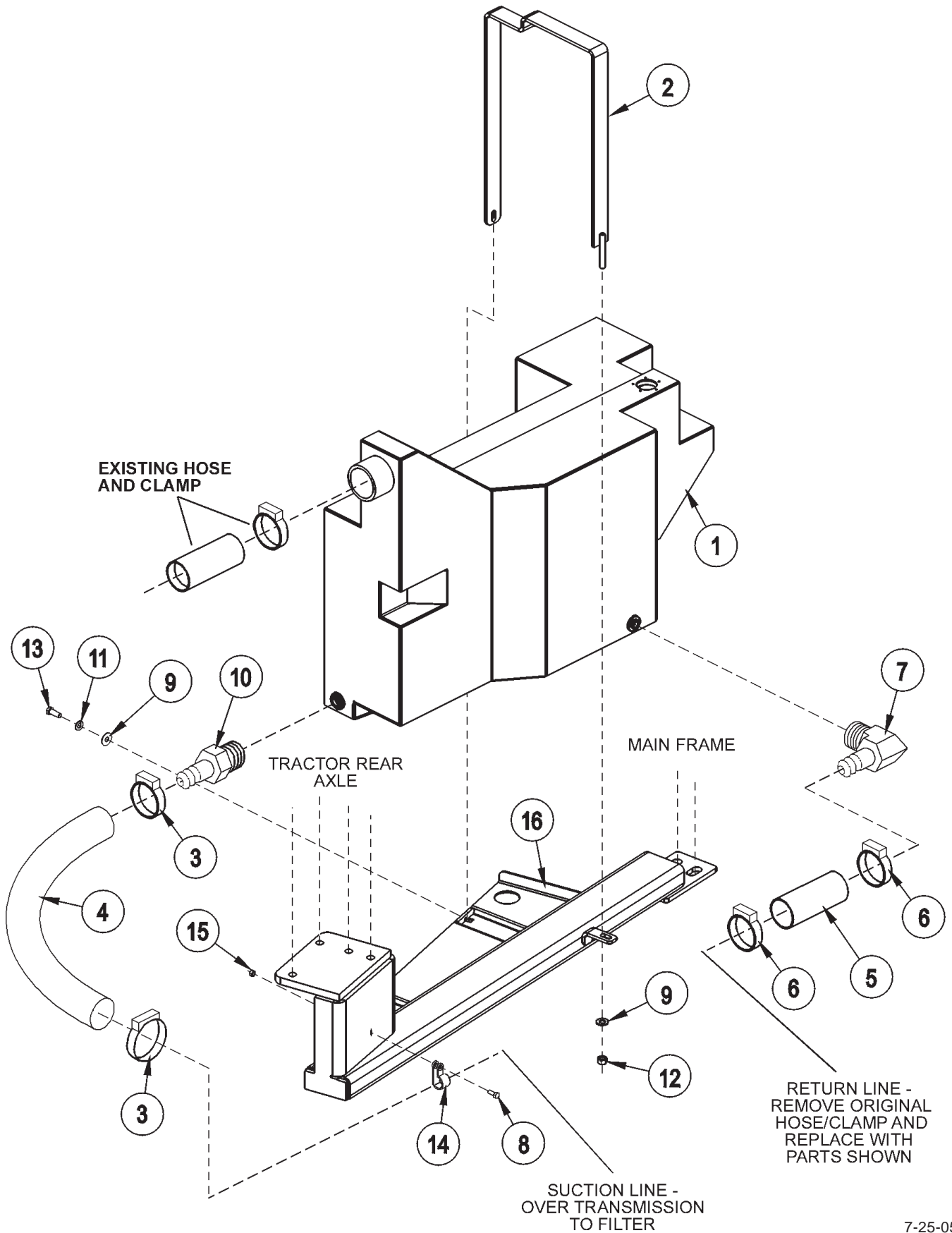

TRACTOR MOUNT KIT - FUEL TANK, CAB, 5525

ITEM	PART NO.	QTY.	DESCRIPTION
1	06370033	1	FUEL TANK
2	06370034	1	TANK STRAP
3	35091	2	HOSE CLAMP, #6
4	34380	4'	FUEL LINE, 3/8"
5	34602	4'	FUEL LINE, 1/4"
6	35086	2	HOSE CLAMP, #4
7	06503092	1	ELBOW, 1/4BARB x 1/4MP
8	21529	1	CAPSCREW 1/4" X 3/4"
9	22016	2	FLATWASHER 3/8"
10	06503038	1	ADAPTER, 3/8BARB x 3/8MP
11	21988	1	LOCKWASHER 3/8"
12	21527	1	NYLOCK NUT 3/8"
13	21630	1	CAPSCREW 3/8" X 1"
14	35119	1	INSULATED CLAMP, 5/8"
15	21525	1	HEX NUT, 1/4" NC
16	*	REF.	AXLE BRACE - REFER TO MAIN FRAME PARTS

TRACTOR MOUNT KIT - HYDRAULICS 5525

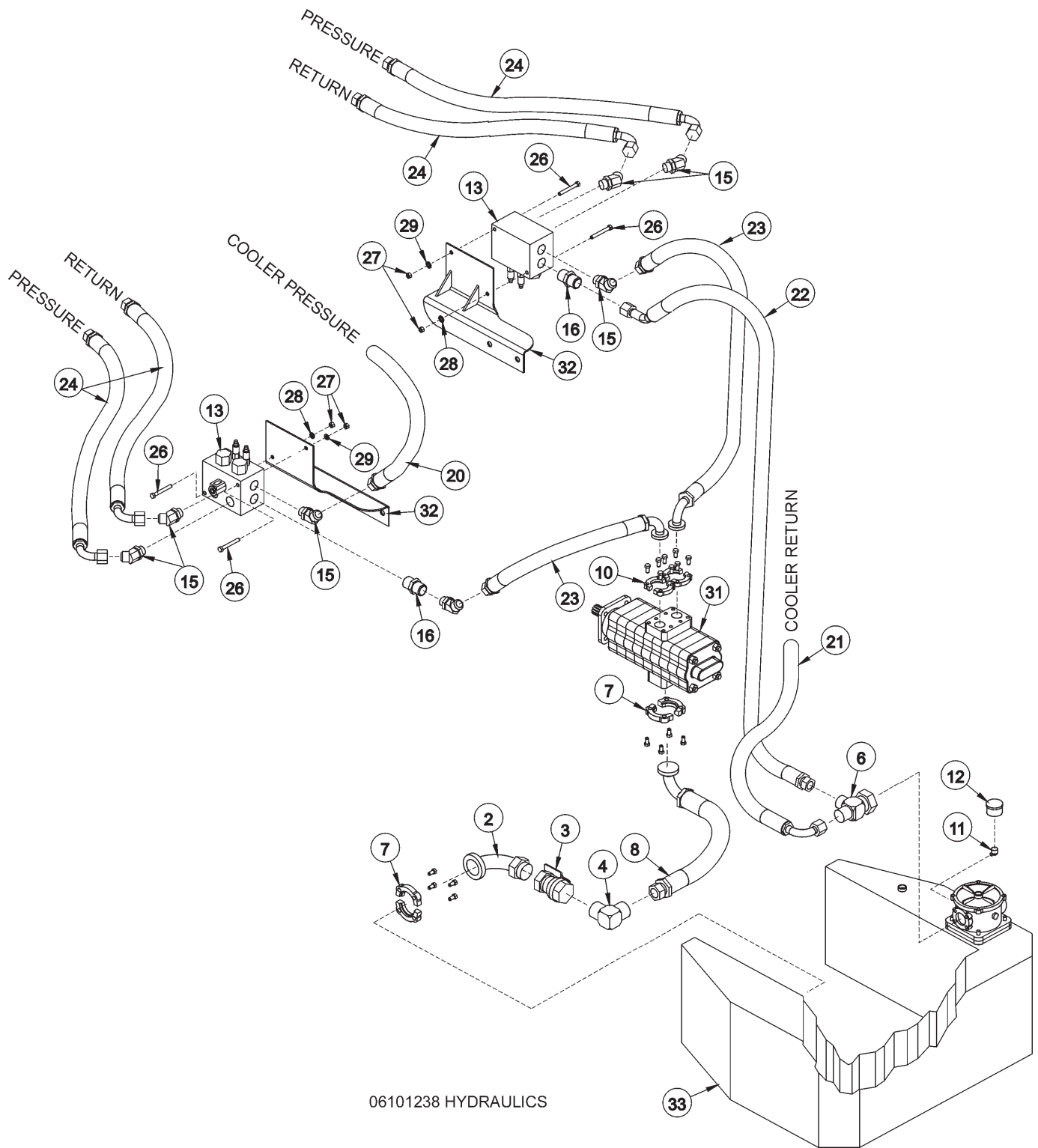

06101238 HYDRAULICS

TRACTOR MOUNT KIT - HYDRAULICS 5525

ITEM	PART NO.	QTY.	DESCRIPTION
2	34389	1	ELBOW, 1 1/2"ORB X 32FLG 90
3	34309	1	BALL VALVE
4	34655	1	ELBOW 1 1/2"ORB X 1 1/2MJ
6	34656	1	TEE,RUN, 1 1/4ORB x 1 1/4MJ x 1 1/4MJ
7	TF4431	2	FLANGE KIT #32
8	06500119	1	HOSE, 1 1/2" X 28"
10	TF4852	2	FLANGE KIT #20
11	TF4887	1	STREET ELBOW
12	6T0649	1	FILTER GAUGE
13	34115	2	BRAKE VALVE
14	24724	1	SWIVEL, 1"MJ X 1"FJX 45
15	33554	6	ELBOW 1"ORB X 1"MJIC 45
16	33555	2	ADAPTER 1"ORB X 1"MJIC
17	6T3200	8	SPLIT HOSE - NOT PICTURED
18	6T1823	12	ZIP TIES 14" - NOT PICTURED
20	06500179	1	HOSE 1" X 50" (COOLER PRESSURE)
21	06500116	1	HOSE 1" X 18" (COOLER RETURN)
22	06500178	1	HOSE 1" X 43"
23	06500177	2	HOSE 1" X 40"
24	34384	4	HOSE 1" X 106"
26	21644	4	CAPSCREW 3/8" X 5"
27	21625	4	HEX NUT 3/8"
28	21988	4	LOCKWASHER 3/8"
31	*	REF.	PUMP - REFER TO MAIN FRAME PARTS
32	*	REF.	SOLENOID BRACKET - REFER TO MAIN FRAME PARTS
33	*	REF.	HYDRAULIC RESERVOIR - REF. TO MAIN FRAME PARTS

LIFT VALVE - 4SP CAB 5525

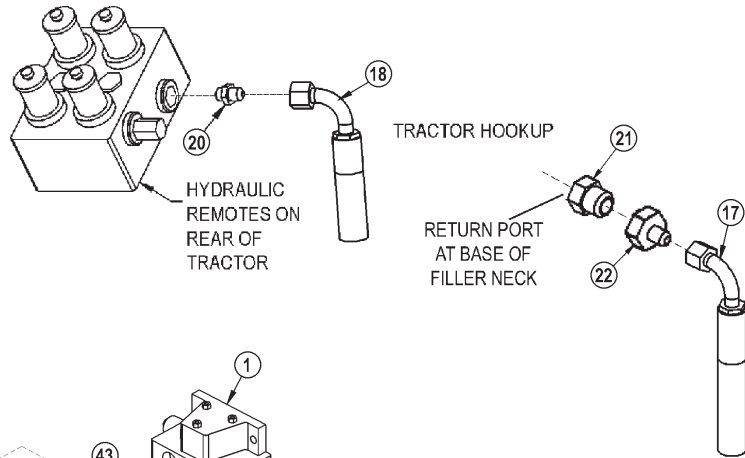

HOSE ROUTING

- A - TO RH OUTBOARD CYLINDER GLAND
- B - TO RH OUTBOARD CYLINDER BUTT
- C - TO RH INBOARD CYLINDER GLAND
- D - TO LH INBOARD CYLINDER GLAND
- E - TO LH OUTBOARD CYLINDER BUTT
- F - TO LH OUTBOARD CYLINDER GLAND

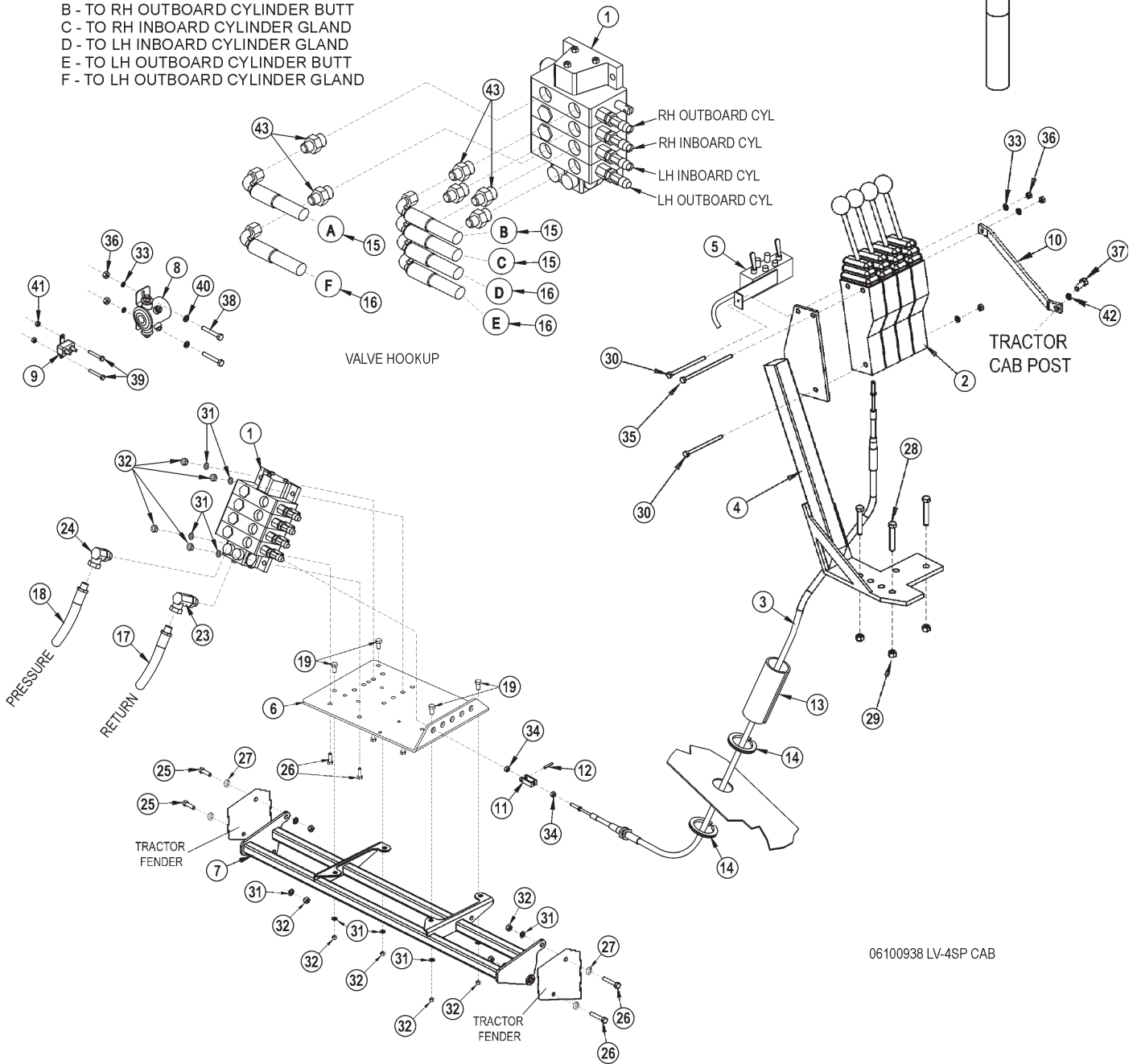

06100938 LV-4SP CAB

LIFT VALVE - 4SP CAB 5525

ITEM	PART NO.	QTY.	DESCRIPTION
1	TF4210	1	VALVE
2	6T1251	4	CABLE CONTROL BOX
3	34623	4	CONTROL CABLE
4	23865B	1	CABLE CONTROL MOUNT BRACKET
5	06510027	1	SWITCH BOX, REV FAN
6	34622	1	VALVE MOUNTING PLATE
7	06340017	1	VALVE MOUNTING BRACKET
8	6T3927	1	CONTINUOUS SOLENOID
9	6T3957	1	CIRCUIT BREAKER
10	06410230	1	CABLE BOX MOUNT SUPPORT
11	6T4411	4	CABLE CONTROL CLEVIS
12	6T3017	4	ROLL PIN
13	6T3200	1	SPLIT HOSE
14	TB3440	8"	TRIM LOCK
15	33364	3	HOSE 1/4" X 120"
16	06500136	3	HOSE 1/4" X 140
17	06500163	1	HOSE 1/2" X 50"
18	06500170	1	HOSE 5/8" x 30"
19	21630	4	CAPSCREW 3/8" X 1"
20	RE62868	1	ADAPTER, PB, JD5525
21	06503032	1	ADAPTER,33MMORBx1MJ
22	06503031	1	ADAPTER,1FJx1/2MJ
23	33748	1	ELBOW,5/8MORB LONG X 5/8MJ
24	06503033	1	ELBOW,5/8MORB X 5/8MJX90
25	21631	2	CAPSCREW 3/8" X 1 1/4"
26	21632	6	CAPSCREW 3/8" X 1 1/2"
27	6T2615	4	FENDER WASHER
28	21634	3	CAPSCREW 3/8" X 2"
29	21627	3	NYLOCK NUT 3/8"
30	21546	2	CAPSCREW 1/4" X 7"
31	21988	12	LOCKWASHER 3/8"
32	21625	12	HEX NUT 3/8"
33	21986	5	LOCKWASHER 1/4"
34	21500	8	HEX NUT 1/4"NF
35	21547	1	CAPSCREW 1/4" X 8"
36	21525	5	HEX NUT 1/4"
37	33534	1	CAPSCREW,10MMX20MM
38	21529	2	CAPSCREW 1/4" X 3/4"
39	30333	2	MACHINE SCREW, 10/32" X 1/2"
40	32360	2	LOCKWASHER, #8
41	27990	2	HEX NUT, 10/32" X 1/2"
42	32724	1	FLATWASHER,10MM
43	33271	6	ADAPTER,1/2 MOR X 3/8 MJ

LIFT VALVE - 4SP CAB 5093-5101E

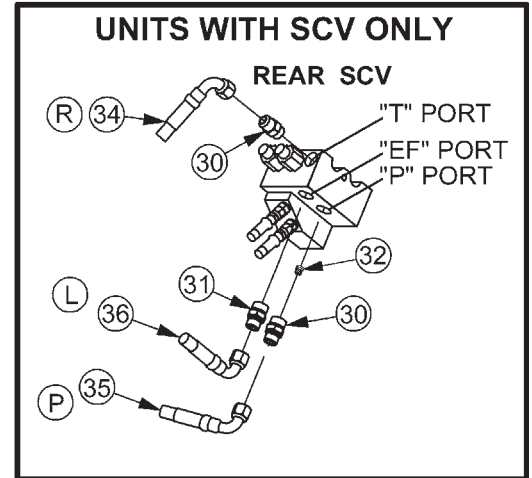
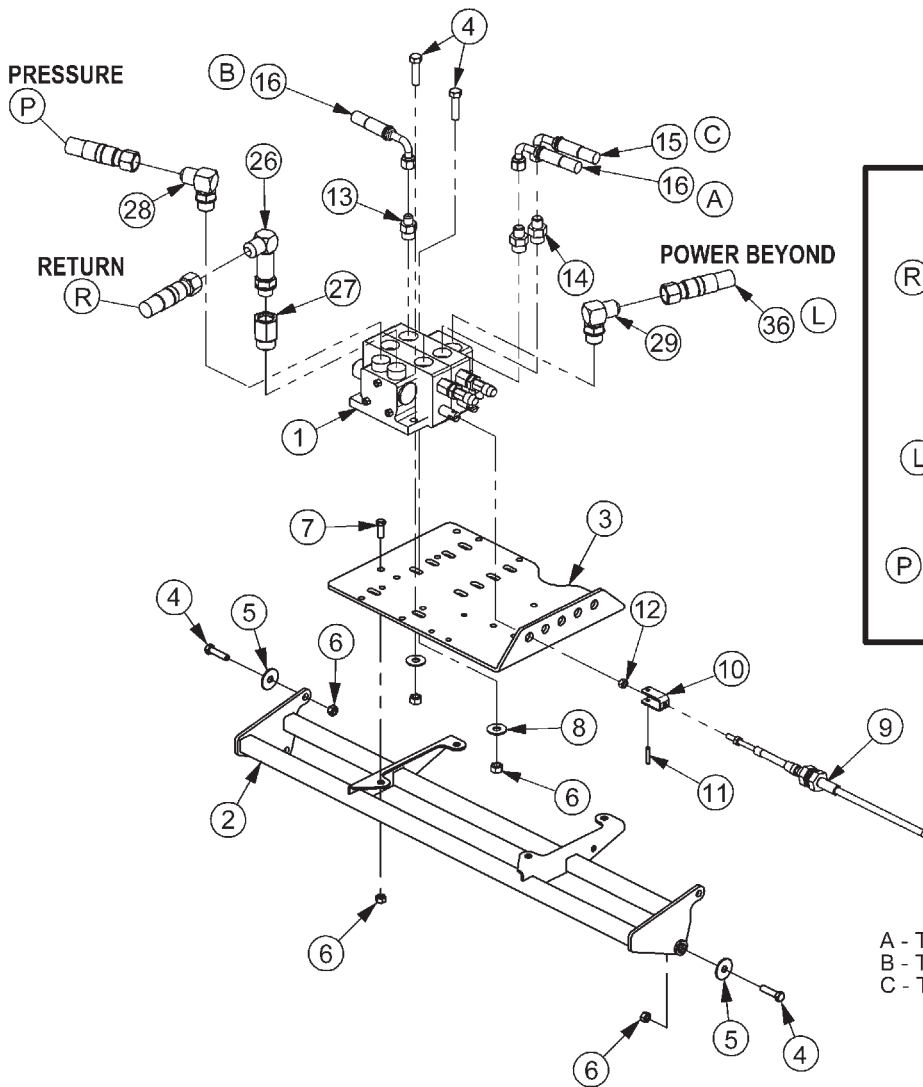

HOSE ROUTING

- A - TO INBOARD CYLINDER GLAND
- B - TO OUTBOARD CYLINDER BUTT
- C - TO OUTBOARD CYLINDER GLAND

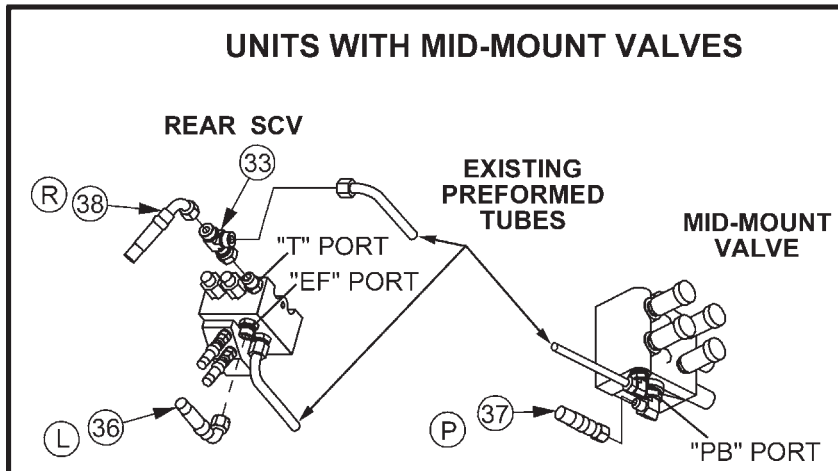

LIFT VALVE - 4SP CAB 5093-5101E

ITEM	PART NO.	QTY.	DESCRIPTION
1		1	VALVE,5SP,HSC,TRB,PB
2	06340017	1	VALVE MNT,JD5525
3	34622	1	PLATE,VALVE,REAR MNT
4	21632	9	CAPSCREW,3/8 X 1-1/2 NC
5	6T2615	4	WASHER,FENDER 3/8
6	21627	13	NYLOCK NUT,3/8 NC
7	21630	4	CAPSCREW,3/8 X 1 NC
8	22016	4	FLATWASHER,3/8
9	06505100	2	CBL,CNTRL,108
10	6T4411	2	CLEVIS,CBL CTRL,3/16
11	6T3017	2	ROLLPIN,3/16 X 1
12	21500	4	HEX NUT,1/4 NF
13	06502036	2	VLV,CHECK,W/.06 ORF,1/2MORx3/8
14	33271	3	ADAPTER,1/2 MOR X 3/8 MJ
15	33745	1	HOSE,#4x100(6FJX90x6FJX)
16	33364	2	HOSE,#4x120(6FJX90x6FJX)
17	21627	1	HOSE,1/4X128(3/8FJX90X3/8FJX)
18	06500164	1	HOSE,1/4X216(3/8FJX90X3/8FJX)
19	33745	1	HOSE,1/4X100(3/8FJX90X3/8FJX)
20	06503029	1	TEE,RUN,1/2ORBx3/8MJx3/8MJ
21	33470	1	ACCUMULATOR,30 CU IN.,1150 PSI
22	23888	1	BRKT,ACCUMULATOR
23	06420054	2	SPACER,75x41 .x2.50
24	21641	2	CAPSCREW,3/8 X 3 3/4 NC
25	21988	2	LOCKWASHER,3/8
26	33293	1	ELBOW,LONG,1/2MOR X 1/2MJIC 90
27	32678	1	ADAPTER,5/8ORB x 1/2FOR
28	33383	1	ELBOW,5/8MORB X 1/2MJ X 90
29	06503033	1	ELBOW,5/8ORBx5/8MJ
30	33463	2	ADAPTER,22mm ORB x 1/2MJ
31	34424	1	FITTING,ADAPTER,22MMX5/8MFS
32	31171	1	PLUG,PIPE 3/8 SKT
33	32872	1	SWIVEL NUT RUN TEE
34	33486	1	HOSE,#8x45(8FJX90x8FJX)
35	33595	1	HOSE,#8x65(8FJX90x8FJX)
36	06500399	1	HOSE,#8x41(10FFSX90x10FJX)
37	06500391	1	HOSE,#8x97(12FFSXx8FJX)
38	06500392	1	HOSE,#8x62(10FFSX90x8FJX)

4SP HUSCO - OPEN CENTER (TF4210)

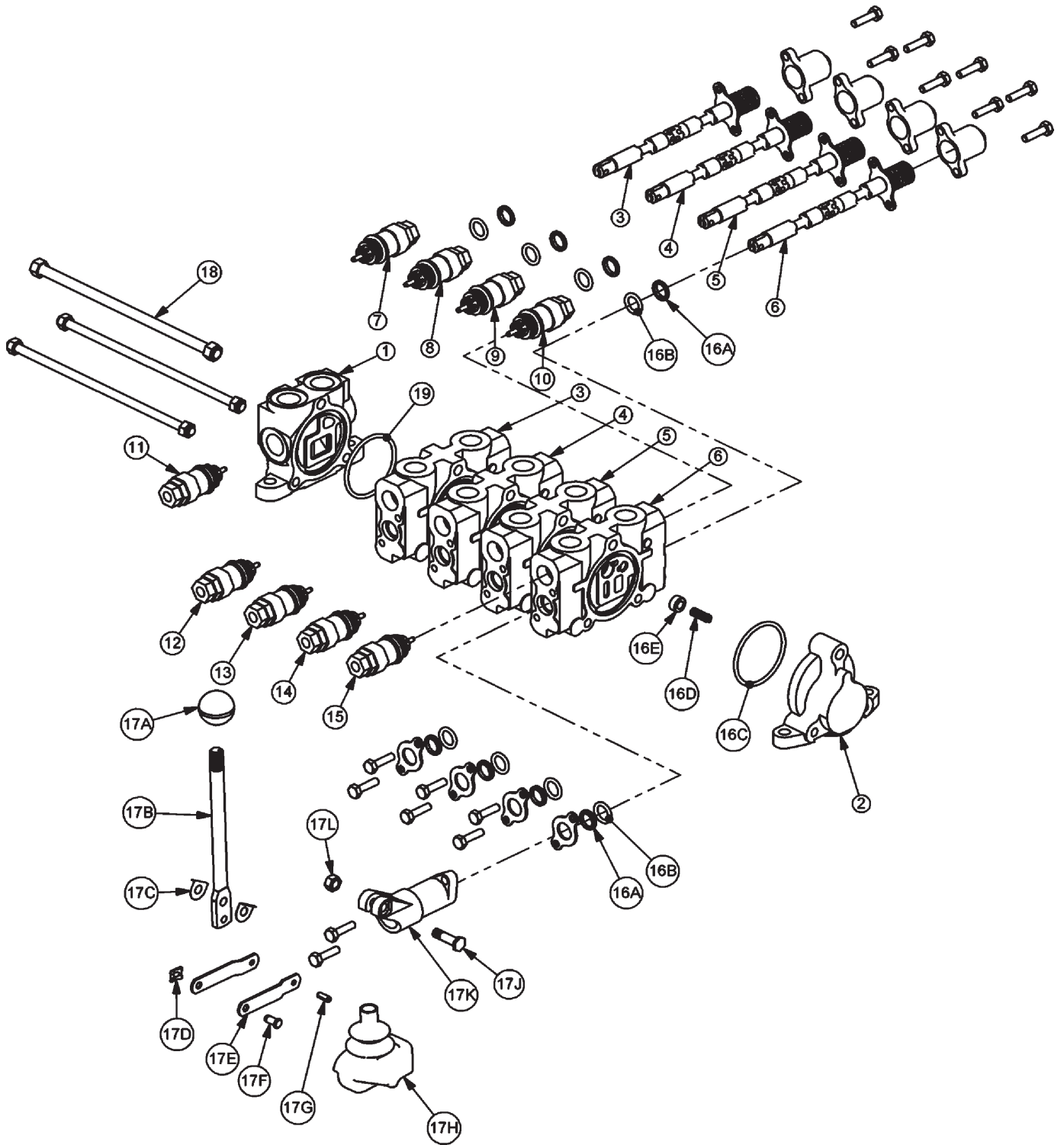

4SP HUSCO - OPEN CENTER (TF4210)

ITEM	PART NO.	QTY	DESCRIPTION
1	TB1017S	1	INLET END COVER
2	TB1701	1	END COVER, OPEN CENTER
3	TF3009	1	VALVE SECTION (DOUBLE ACTING, DETENT - FLOAT)
4	TF3009	1	VALVE SECTION (DOUBLE ACTING, DETENT - FLOAT)
5	TF3009	1	VALVE SECTION (DOUBLE ACTING, DETENT - FLOAT)
6	TF3009	1	VALVE SECTION (DOUBLE ACTING, DETENT - FLOAT)
7	TF4212	1	RELIEF VALVE, 200 PSI
8	06503067	1	RELIEF PLUG
9	06503067	1	RELIEF PLUG
10	TF4212	1	RELIEF VALVE, 200 PSI
11	TF4213	1	RELIEF VALVE, 2000 PSI
12	TB1017M	1	SHUT-OFF PLUG
13	TB1017M	1	SHUT-OFF PLUG
14	TB1017M	1	SHUT-OFF PLUG
15	TB1017M	1	SHUT-OFF PLUG
16	TB1017A	4	VALVE SEAL KIT (FOR ONE SECTION)
16A		2	WIPER
16B		2	O-RING SMALL
16C		1	O-RING LARGE
16D		1	SPRING
16E		1	PUCKET
17	TB1017L	4	LEVER KIT (FOR ONE SECTION)
17A		1	LEVER KNOB
17B		1	LEVER
17C		2	LEVER WASHER
17D		1	LEVER CLIP
17E		2	LINKAGE
17F		1	LEVER PIN
17G		1	ROLL PIN
17H		1	LEVER BOOT
17J		1	LEVER BOLT
17K		1	LEVER DUST COVER
17L		1	LEVER NUT
18	TB1017U	1	TIE ROD KIT
19	24214	1	O-RING, LARGE

DRAFT BEAM - RIGHT HAND

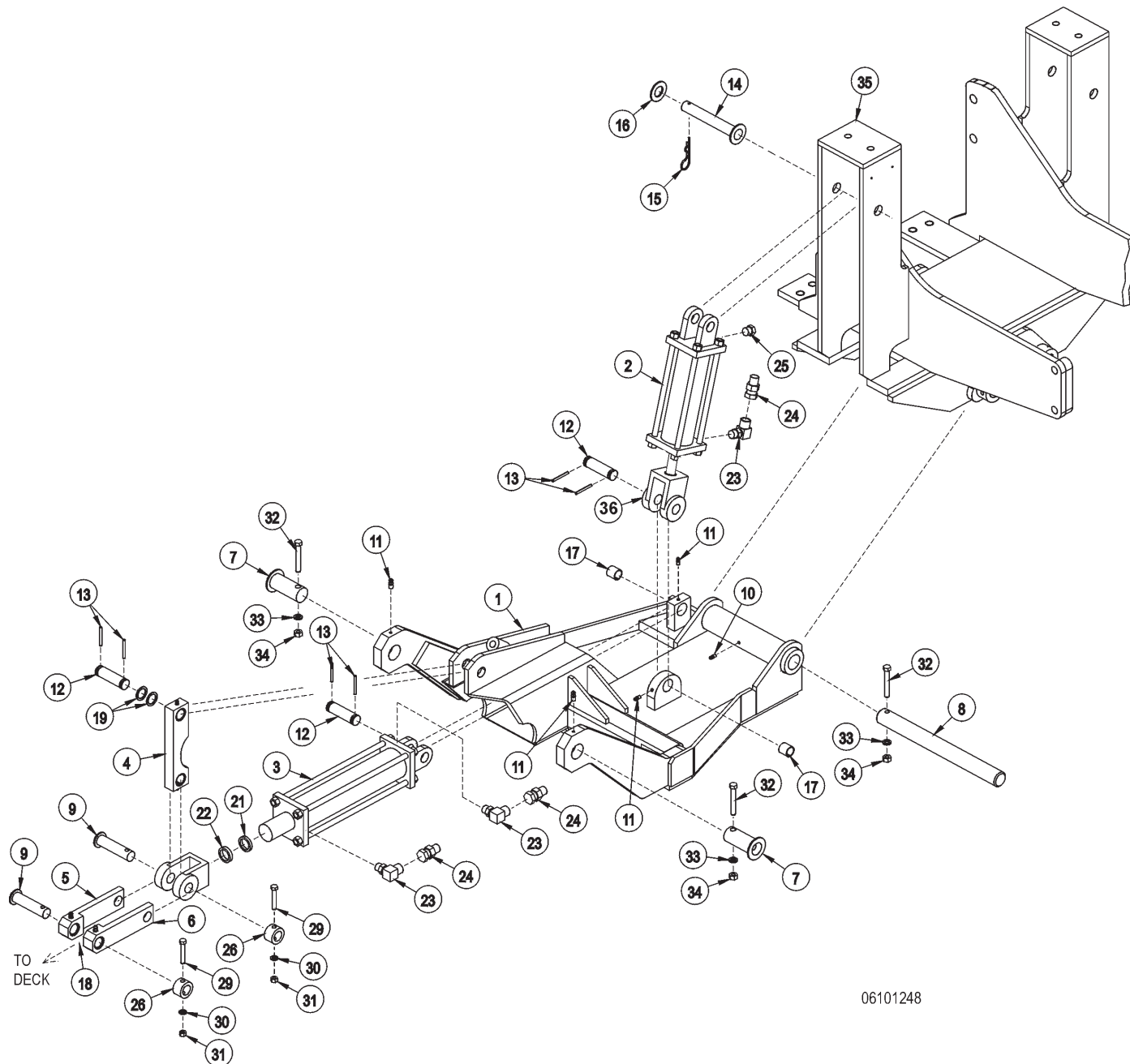

06101248

DRAFT BEAM - RIGHT HAND

ITEM	PART NO.	QTY.	DESCRIPTION
1	32164	1	RIGHT HAND DRAFT BEAM
2	31211	1	INBOARD CYLINDER W/ SPACER
3	32215	1	OUTBOARD CYLINDER
4	TF4500A	1	PIVOT ARM
5	TF4506B	1	LIFT ARM - LH
6	TF4507B	1	LIFT ARM - RH
7	30126B	2	PIN
8	6T3001	1	PIN
9	TF4519	2	PIN
10	6T3207	1	GREASE ZERK
11	6T3211	4	GREASE ZERK
12	TB1033	3	CLEVIS PIN
13	06537021	6	ROLL PIN
14	6T3005	1	CYLINDER PIN
15	6T3004	1	R-CLIP
16	6T2614	1	FLATWASHER - 1"
17	TB3010	2	BUSHING
18	23724	3	SPACER - AS NEEDED
19	22973A	2	SHIM
21	22076	2	SPACER - AS NEEDED
22	22077	2	SPACER - AS NEEDED
23	34244	3	ELBOW 1/2 ORB X 1/2 FOR
24	34396	3	ADAPTER RESTRICTOR
25	6T4258	1	BREATHER
26	22847	2	BOSS
29	21635	2	CAPSCREW - 3/8" X 2 1/4"
30	21988	2	LOCKWASHER - 3/8"
31	21625	2	HEX NUT - 3/8"
32	21688	3	CAPSCREW - 7/16" X 3 1/4"
33	21989	3	LOCKWASHER - 7/16"
34	21675	3	HEX NUT - 7/16"
35	*	REF.	MAIN FRAME - REFER TO MAIN FRAME PARTS

DRAFT BEAM - LEFT HAND

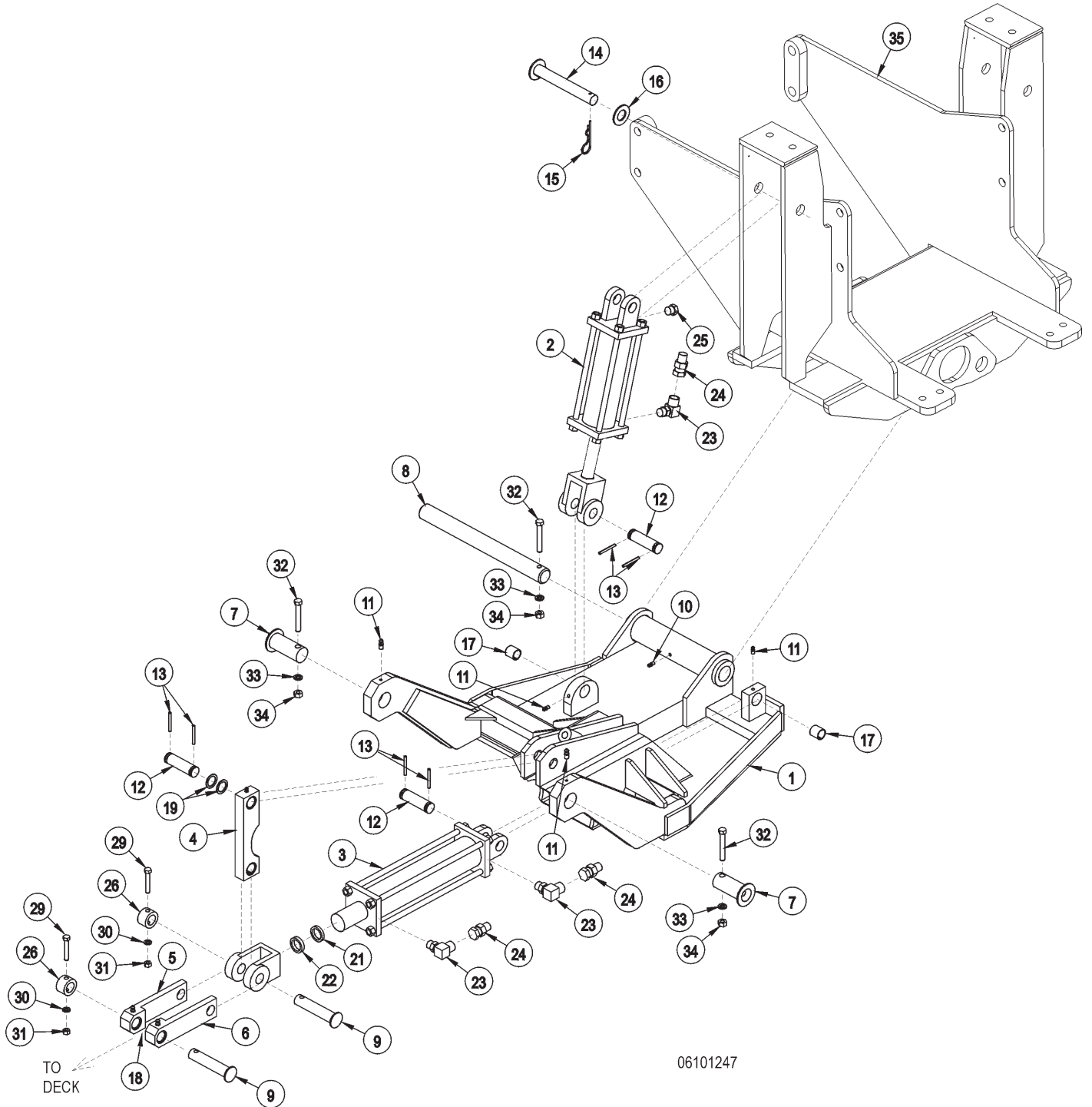

DRAFT BEAM - LEFT HAND

ITEM	PART NO.	QTY.	DESCRIPTION
1	32165	1	LEFT HAND DRAFT BEAM
2	30481	1	INBOARD CYLINDER W/ SPACER
3	32215	1	OUTBOARD CYLINDER
4	TF4500A	1	PIVOT ARM
5	TF4506B	1	LIFT ARM - LH
6	TF4507B	1	LIFT ARM - RH
7	30126B	2	PIN
8	6T3001	1	PIN
9	TF4519	2	PIN
10	6T3207	1	GREASE ZERK
11	6T3211	4	GREASE ZERK
12	TB1033	3	CLEVIS PIN
13	06537021	6	ROLL PIN
14	6T3005	1	CYLINDER PIN
15	6T3004	1	R-CLIP
16	6T2614	1	FLATWASHER - 1"
17	TB3010	2	BUSHING
18	23724	3	SPACER - AS NEEDED
19	22973A	2	SHIM
21	22076	2	SPACER - AS NEEDED
22	22077	2	SPACER - AS NEEDED
23	34244	3	ELBOW 1/2 ORB X 1/2 FOR
24	34396	3	ADAPTER RESTRICTOR
25	6T4258	1	BREATHER
26	22847	2	BOSS
29	21635	2	CAPSCREW - 3/8" X 2 1/4"
30	21988	2	LOCKWASHER - 3/8"
31	21625	2	HEX NUT - 3/8"
32	21688	3	CAPSCREW - 7/16" X 3 1/4"
33	21989	3	LOCKWASHER - 7/16"
34	21675	3	HEX NUT - 7/16"
35	*	REF.	MAIN FRAME - REFER TO MAIN FRAME PARTS

HYDRAULIC COOLER ASSEMBLY, CAB

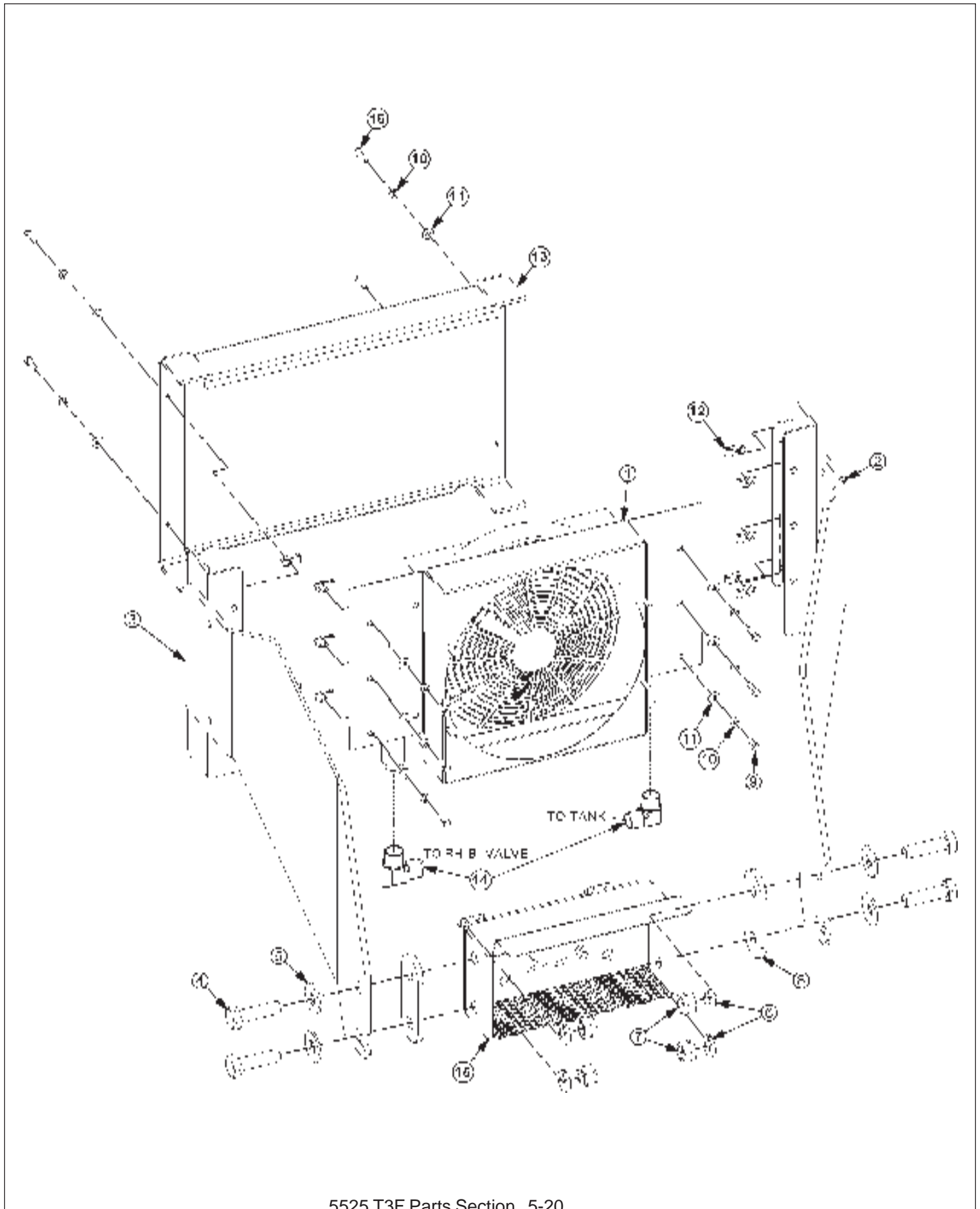

HYDRAULIC COOLER ASSEMBLY, CAB

ITEM	PART NO.	QTY.	DESCRIPTION
1	06510026	1	COOLER, SNGL FAN, 350BTU
	06510029	AVAIL.	FAN ASSY, COOLERS, 06510025-26
2	06370012	1	COOLER MNT, RH, FRNT, PMP MNT
3	06370013	1	COOLER MNT, LH, FRNT, PMP MNT
4	21835	4	CAPSCREW, 3/4 X 2-3/4 NC
5	22021	4	FLATWASHER, 3/4
6	21993	4	LOCKWASHER, 3/4, GR 8
7	21825	4	HEX NUT, 3/4 NC
8	06400165	2	SPACER, COOLER, FRONT
9	21529	10	CAPSCREW, 1/4 X 3/4" NC
10	21986	10	LOCKWASHER, 1/4
11	22014	10	FLATWASHER, 1/4
12	35176	10	U-NUT, 1/4, 3/4 TO CENTER
13	06370015	1	SCREEN, COOLER, FRNT
14	34117	2	ELBOW, 1MOR X 1MJ90, FORGED
15	32408	1	PUMP MTG BRKT, FD81-8560
16	21530	1	CAPSCREW, 1/4" X 1" NC

POLYCARBONATE SAFETY WINDOW - 5525, CAB

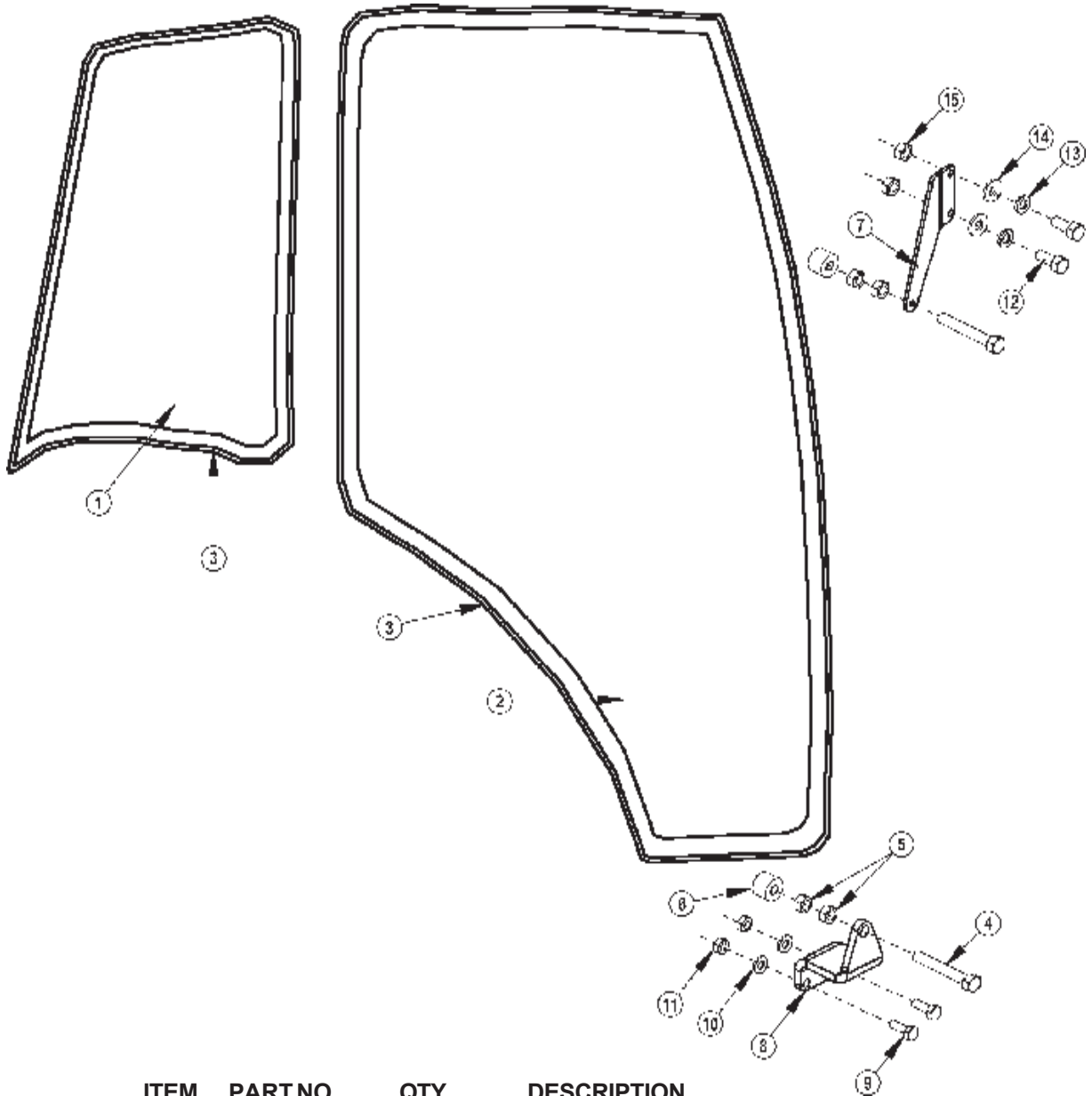

ITEM	PART NO.	QTY.	DESCRIPTION
1	06490014	1	POLYCARB, FRMD, REAR
2	06490013	1	POLYCARB, FRMD, DOOR
3	31965	25'	TRIM SEAL
4	21584	2	CAPSCEW, 5/16" X 2" NC
5	21575	6	HEX NUT, 5/16" NC
6	33477	2	VIBRATIONISOLATOR
7	06410268	1	TOP BRACKET
8	06410269	1	BOTTOM BRACKET
9	21529	2	CAPSCEW, 1/4" X 3/4" NC
10	21986	2	LOCKWASHER, 1/4"
11	21525	2	HEX NUT, 1/4" NC
12	27508	2	CAPSCEW, 8MMX20MM(1.25)
13	6T2619	2	LOCKWASHER, 8MM
14	34948	2	WASHER, 8MM
15	*	2	HEX NUT
	06537005	1	3M ADHESIVE

SOLENOID VALVE SWITCH AND WIRING

TWIN & TRIPLE WIRING SCHEMATIC REAR MOUNTED COOLER

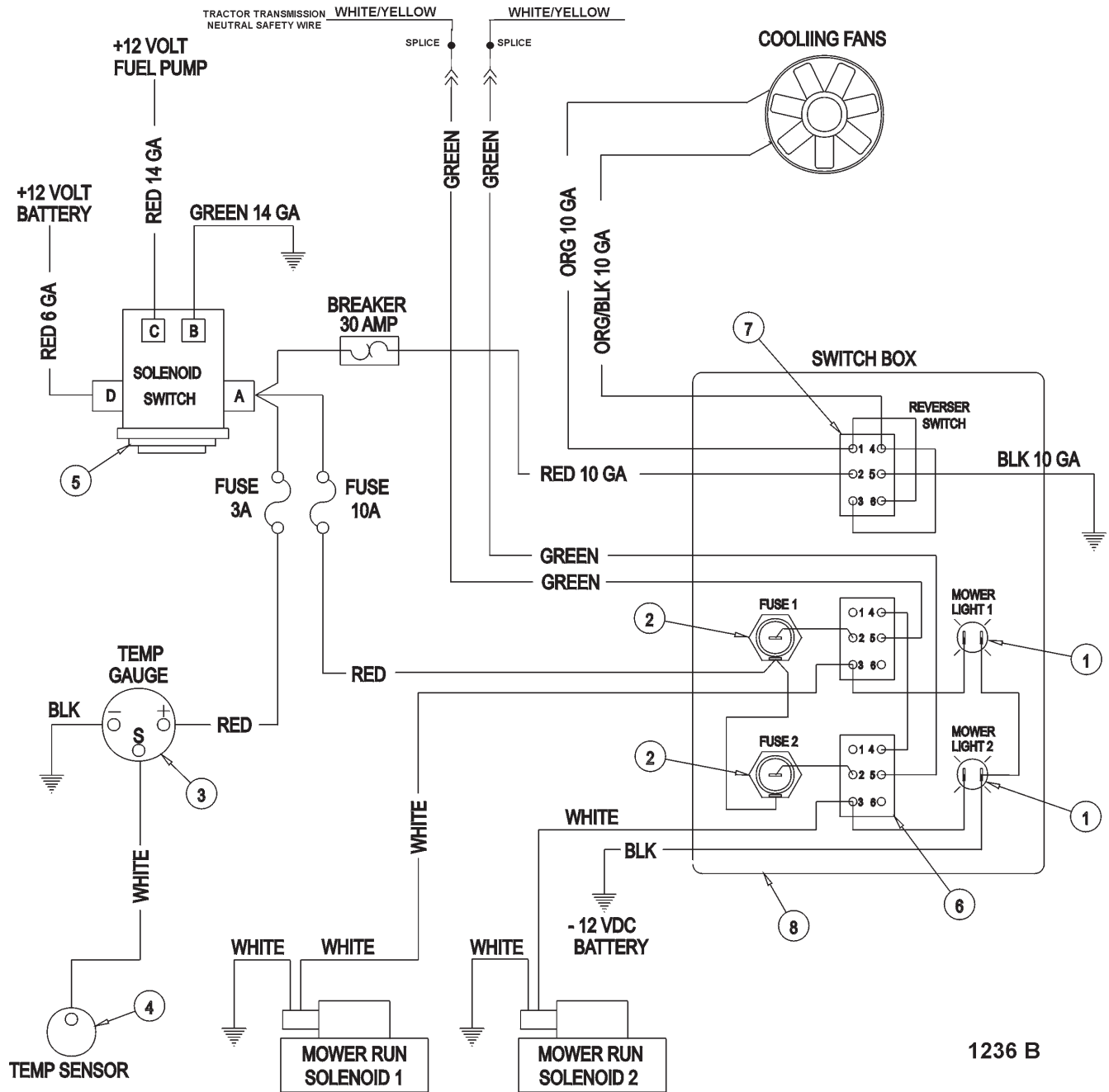

1236 B

ITEM	PART NO.	QTY.	DESCRIPTION
	34522	AVAIL	SWITCH BOX ASY (COMPLETE)
1	6T3923	1	INDICATOR LIGHT
2	6T3924	1	FUSE HOLDER
3	6T3934	OPT.	TEMPERATURE GAUGE
4	6T3931	OPT.	TEMPERATURE SENSOR
5	6T3927	1	CONTINUOUS SOLENOID SWITCH
6	PT3905A	1	TOGGLE SWITCH, MOWER RUN
7	30260	1	TOGGLE SWITCH, REVERSER SWITCH
8	34325	1	SWITCH BOX

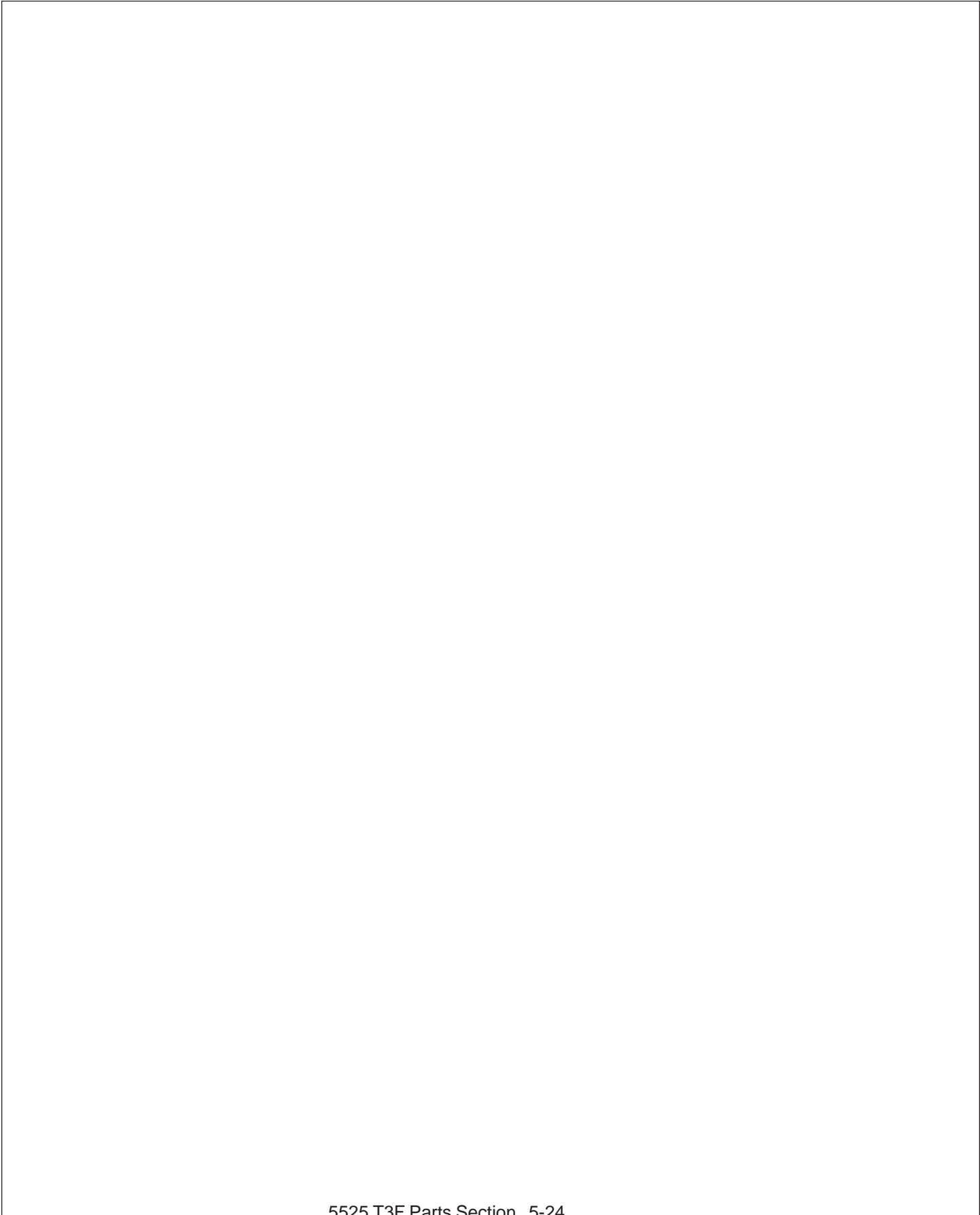

TRIPLE MOWER COMMON SECTION

COMMON PARTS SECTION

TABLE OF CONTENTS

SECTION SPECIFIC PARTS	PAGE
DRAFT BEAM - LEFT HAND	6-4
DRAFT BEAM - RIGHT HAND	6-6
STD DUTY 63" SIDE DECK	6-8
STD DUTY 75" SIDE DECK	6-12
STD DUTY SIDE FLAIL DRIVE ASSEMBLY	6-16
HVY DUTY 75" SIDE DECK	6-18
HVY DUTY 90" SIDE DECK	6-22
HVY DUTY SIDE FLAIL DRIVE ASSEMBLY	6-26
STD DUTY 75" REAR DECK	6-28
STD DUTY 90" REAR DECK	6-32
STD DUTY REAR FLAIL DRIVE ASSY	6-36
STD DUTY PTO DRIVE ASSY	6-38
HVY DUTY 75" REAR DECK	6-40
HVY DUTY 75" REAR DRIVE ASSEMBLY	6-44
HVY DUTY 90" REAR DECK	6-46
HVY DUTY 90" REAR DRIVE ASSEMBLY	6-50
HVY DUTY 96" REAR DECK	6-52
HVY DUTY 96" REAR DRIVE ASSEMBLY	6-56
HVY DUTY 102" REAR DECK	6-58
HVY DUTY 102" REAR DECK DRIVE ASSEMBLY	6-62
GEAR BOX ASSY	6-64
REAR FLAIL PTO SHAFT ASSEMBLIES	6-68
CLUTCH ASSEMBLY	6-70
RESERVOIR TANK FILTER ASSEMBLY	6-72
FRONT PUMP ASSEMBLY	6-73
SIDE DECK MOTORS	6-74
HYDRAULIC LIFT CYLINDER	6-78
FLAIL LIFT VALVE	6-82
COOLER ASSEMBLY	6-86
CASTER WHEEL, REAR DECK	6-88
SIDE FLAIL TRAVEL LOCK	6-90
SOLENOID BRAKE VALVE ASSEMBLY	6-91
BRAKE VALVE ASSEMBLY W/METRI PAK	6-92
SOLENOID BRAKE VALVE HYDRO SCHEMATIC	6-93
DECAL LOCATION	6-94
SWITCHBOX	6-95
SWITCHBOX SCHEMATIC	6-96
PTO STAND	6-97

PARTS ORDERING GUIDE

The following instructions are offered to help eliminate needless delay and error in processing purchase orders for the equipment in this manual.

1. The Parts Section is prepared in logical sequence and grouping of parts that belong to the basic machine featured in this manual. Part Numbers and Descriptions are given to help locate the parts and quantities required.

2. The Purchase Order must indicate the **Name and Address** of the person or organization ordering the parts, **who should be charged**, and if possible, the **serial number of the machine** for which the parts are being ordered.

3. The purchase order must clearly list the **quantity of each part**, the complete and correct **part number**, and the basic **name of the part**.

4. The manufacturer reserves the right to substitute parts where applicable.

5. Some parts may be unlisted items which are special production items not normally stocked and are subject to special handling. Request a quotation for such parts before sending a purchase order.

6. The manufacturer reserves the right to change prices without prior notice.

NOTE: When ordering replacement decals, refer to the part numbers and descriptions listed in the safety section in the front of this manual.



1000

For maximum safety and to guarantee optimum product reliability, always use genuine **Tiger** replacement parts. The use of inferior replacement parts may cause premature or catastrophic failure which could result in serious injury or death.

Direct any questions regarding parts to:

Tiger Corporation
3301 N. Louise Ave.
Sioux Falls, SD 57107
1-800-843-6849
1-605-336-7900

DRAFT BEAM - LEFT HAND

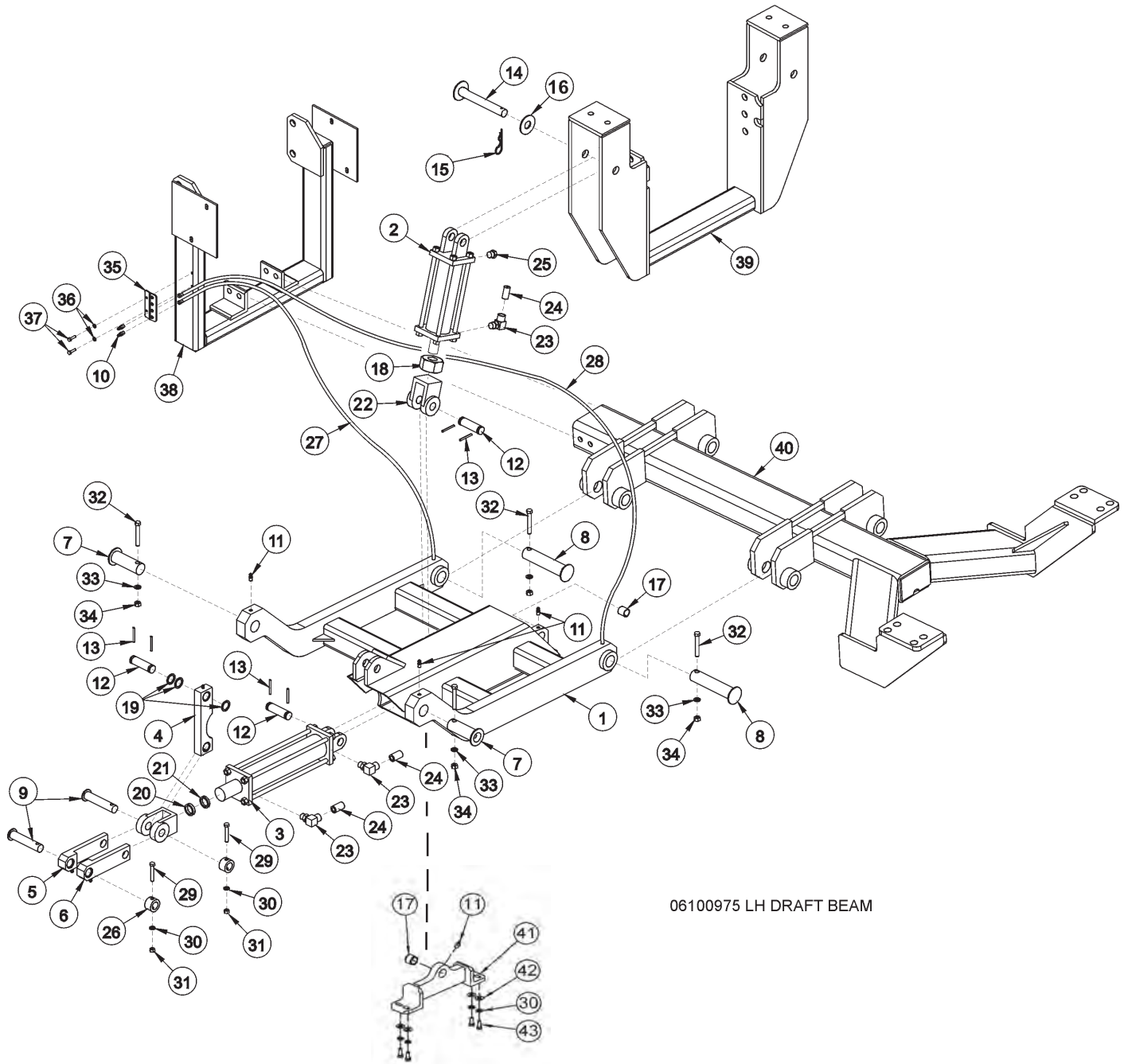

06100975 LH DRAFT BEAM

DRAFT BEAM - LEFT HAND

ITEM	PART NO.	QTY.	DESCRIPTION
1	30975B	1	LEFT HAND DRAFT BEAM
2	30481	1	INBOARD CYLINDER
3	25343	1	OUTBOARD CYLINDER
4	TF4500A	1	PIVOT ARM
5	TF4506B	1	LIFT ARM - LH
6	TF4507B	1	LIFT ARM - RH
7	TF4514A	2	PIN
8	TF4515	2	PIN 1 1/2" X 6 3/4"
9	TF4519	2	PIN
10	TF1033	2	GREASE ZERK 1/8"
11	6T3207	4	GREASE ZERK 1/4"
12	TB1033	3	CLEVIS PIN
13	06537021	6	ROLL PIN
14	6T3005	1	CYLINDER PIN
15	6T3004	1	R-CLIP
16	22023	1	FLATWASHER
17	TB3010	2	BUSHING
18	06531001	1	JAM NUT
19	22973A	3	SHIM
20	22076	1	SPACER (AS REQUIRED)
21	22077	1	SPACER (AS REQUIRED)
22	06520004	1	CLEVIS
23	34244	3	FITTING
24	34396	3	RESTRICTOR
25	6T4258	1	BREATHER
26	22847	2	BOSS
27	22851	1	HOSE 3/16" X 37"
28	22660	1	HOSE 3/16" X 70"
29	21635	2	CAPSCREW - 3/8" X 2 1/4"
30	21988	6	LOCKWASHER - 3/8"
31	21625	2	HEX NUT - 3/8"
32	21688	4	CAPSCREW - 7/16" X 3 3/4"
33	21989	4	LOCKWASHER - 7/16"
34	21675	4	HEX NUT - 7/16"
35	22625	1	GREASE HOSE BRACKET
36	21986	2	LOCKWASHER 1/4"
37	21529	2	CAPSCREW 1/4" X 3/4"
38	*	REF	HANGER - REFER TO TRACTOR PARTS SECTION
39	*	REF	MAST - REFER TO TRACTOR PARTS SECTION
40	*	REF	FRAME - REFER TO TRACTOR PARTS SECTION
41	06350000	1	CYLINDER ANCHOR
42	22016	4	FLATWASHER, 3/8"
43	21630	4	CAPSCREW, 3/8" X 1", NC

DRAFT BEAM - RIGHT HAND

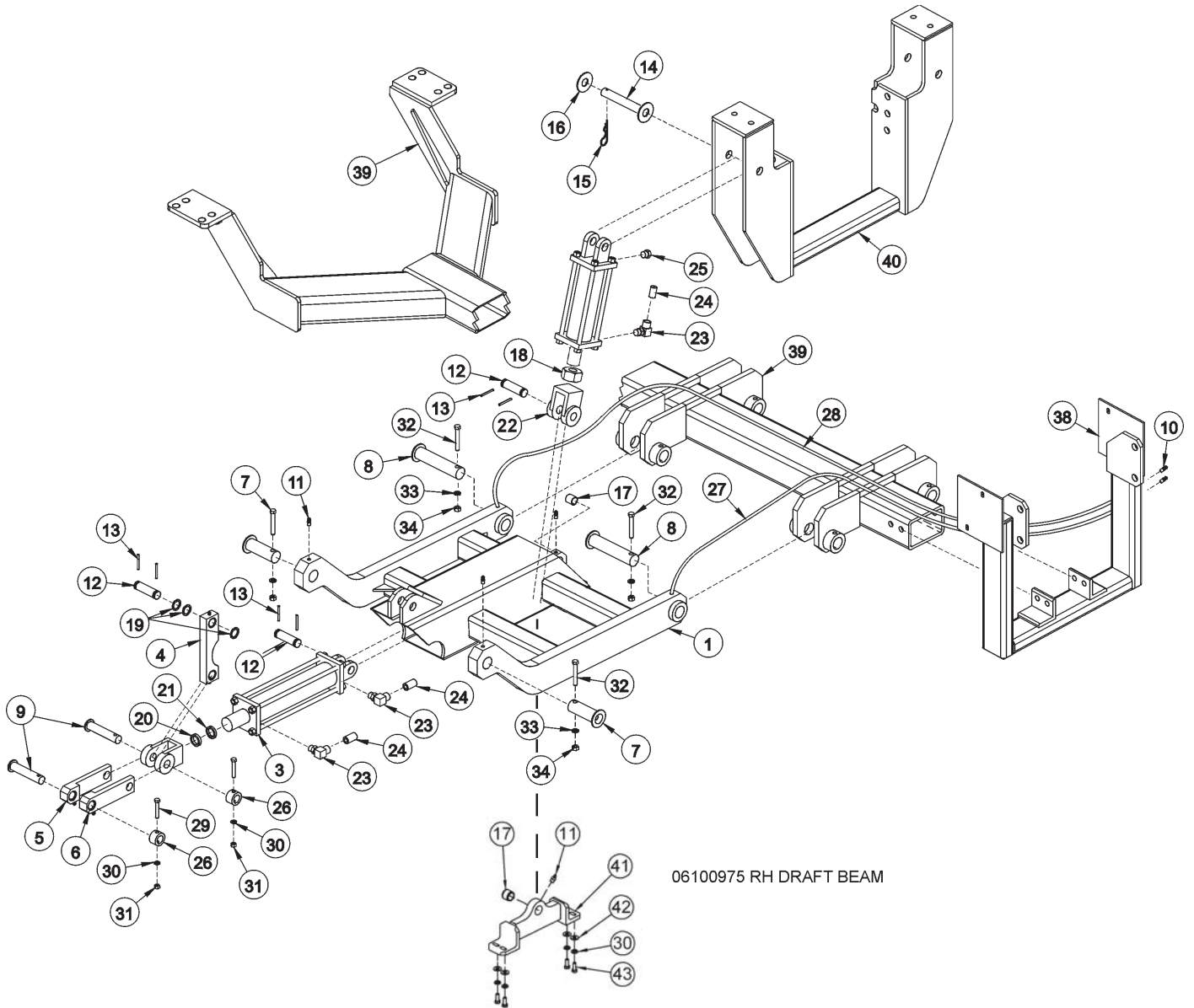

06100975 RH DRAFT BEAM

DRAFT BEAM - RIGHT HAND

ITEM	PART NO.	QTY.	DESCRIPTION
1	30974B	1	RIGHT HAND DRAFT BEAM
2	30481	1	INBOARD CYLINDER
3	25343	1	OUTBOARD CYLINDER
4	TF4500A	1	PIVOT ARM
5	TF4506B	1	LIFT ARM - LH
6	TF4507B	1	LIFT ARM - RH
7	TF4514A	2	PIN
8	TF4515	2	PIN 1 1/2" X 6 3/4"
9	TF4519	2	PIN
10	TF1033	2	GREASE ZERK 1/8"
11	6T3207	4	GREASE ZERK 1/4"
12	TB1033	3	CLEVIS PIN
13	06537021	6	ROLL PIN
14	6T3005	1	CYLINDER PIN
15	6T3004	1	R-CLIP
16	22023	1	FLATWASHER
17	TB3010	2	BUSHING
18	06531001	1	JAM NUT
19	22973A	3	SHIM
20	22076	1	SPACER (AS REQUIRED)
21	22077	1	SPACER (AS REQUIRED)
22	06520004	1	CLEVIS
23	34244	3	FITTING
24	34396	3	RESTRICTOR
25	6T4258	1	BREATHER
26	22847	2	BOSS
27	22851	1	HOSE 3/16" X 37"
28	22860	1	HOSE 3/16" X 70"
29	21635	2	CAPSCREW - 3/8" X 2 1/4"
30	21988	6	LOCKWASHER - 3/8"
31	21625	2	HEX NUT - 3/8"
32	21688	4	CAPSCREW - 7/16" X 3 1/4"
33	21989	4	LOCKWASHER - 7/16"
34	21675	4	HEX NUT - 7/16"
38	*	REF	HANGER - REFER TO TRACTOR PARTS SECTION
39	*	REF	FRAME - REFER TO TRACTOR PARTS SECTION
40	*	REF	MAST - REFER TO TRACTOR PARTS SECTION
41	06350000	1	CYLINDER ANCHOR
42	22016	4	FLATWASHER, 3/8"
43	21630	4	CAPSCREW, 3/8" X 1"

STD DUTY 63" SIDE FLAIL, STANDARD ROTATION

ITEM	P/N	QTY	DESCRIPTION
1	32433	1	BONNET,63,STD,T3F,RH (RIGHT FLAIL)
	32224	1	BONNET,63,STD,T3F,LH (LEFT FLAIL)
2	28665A	1	BAFFLE,63,STD ROT-STD
3	6T2283	8	CARRIAGE BOLT,3/8 X 1 NC
4	6T2615	8	WASHER,FENDER 3/8
5	21988	18	LOCKWASHER,3/8
6	21625	40	HEX NUT,3/8 NC
7	27975A	1	GUARD,CUTTERSCHAFT 5
8	21731	4	CAPSCREW,1/2 X 1-1/2 NC
9	21990	6	LOCKWASHER,1/2
10	21725	6	HEX NUT,1/2 NC
11	28735	2	GROUND ROLLER ADJ BRKT,STD DTY
12	06520028	2	BEARING,FLANGE,1 3/8,GRNDRLR
13	06520027	2	CAP,BEARING,GRNDRLR
14	06520029	2	O-RING,2 3/4x3/32,AS568A-148
15	06530001	12	CAPSCREW,SKT HD,8-32x1/2,SS
16	TF1045B	2	STUB SHAFT,GROUND ROLLER
17	28650A	1	GROUND ROLLER,63
18	6T2330	8	CAPSCREW,SKT HD,7/16X1-1/2NC
19	6T2331	8	CAPSCREW,SKT HD,7/16 X 1 NC
20	28086A	2	SKID SHOE,STD DUTY REAR FLAIL
21	30013	9	PLOW BOLT,3/8 X 1-1/4NC GR5
22	28743	1	CUTTERSCHAFT ASSY,STANDARD(22, 23, 24, 25 & 26)
23	33713	64	KNIFE,FLAIL,SHORT,FORGES GORCE
24	TF1020	32	KNIFE MTG CLEVIS,FLAIL
25	34011	32	CAPSCREW,7/16x3 7/16,NC GR8
26	21677	32	NYLOCK NUT,7/16 NC
	06200639	*	STRING GUARD KIT, SD (ITEMS 27,29,30)
27	33863	2	STRING GUARD, SD
28	28683	2	BEARING,FLANGE,1-15/16STD TSF
29	06530217	8	CAPSCREW,1/2 X 2,NC,L9
30	06533006	8	FLATWASHER,1/2,SAE,L9
31	21732	2	CAPSCREW,1/2 X 1-3/4 NC
32	28700	2	BAR,FLAP,TSF/TBF 63
33	28701	1	FLAP,DEFLECTOR,TSF 63
34	06520241	1	FLAP,63",FRONT
35	21632	22	CAPSCREW,3/8 X 1-1/2 NC
36	22016	44	FLATWASHER,3/8

STD DUTY 63" SIDE FLAIL, REVERSE ROTATION

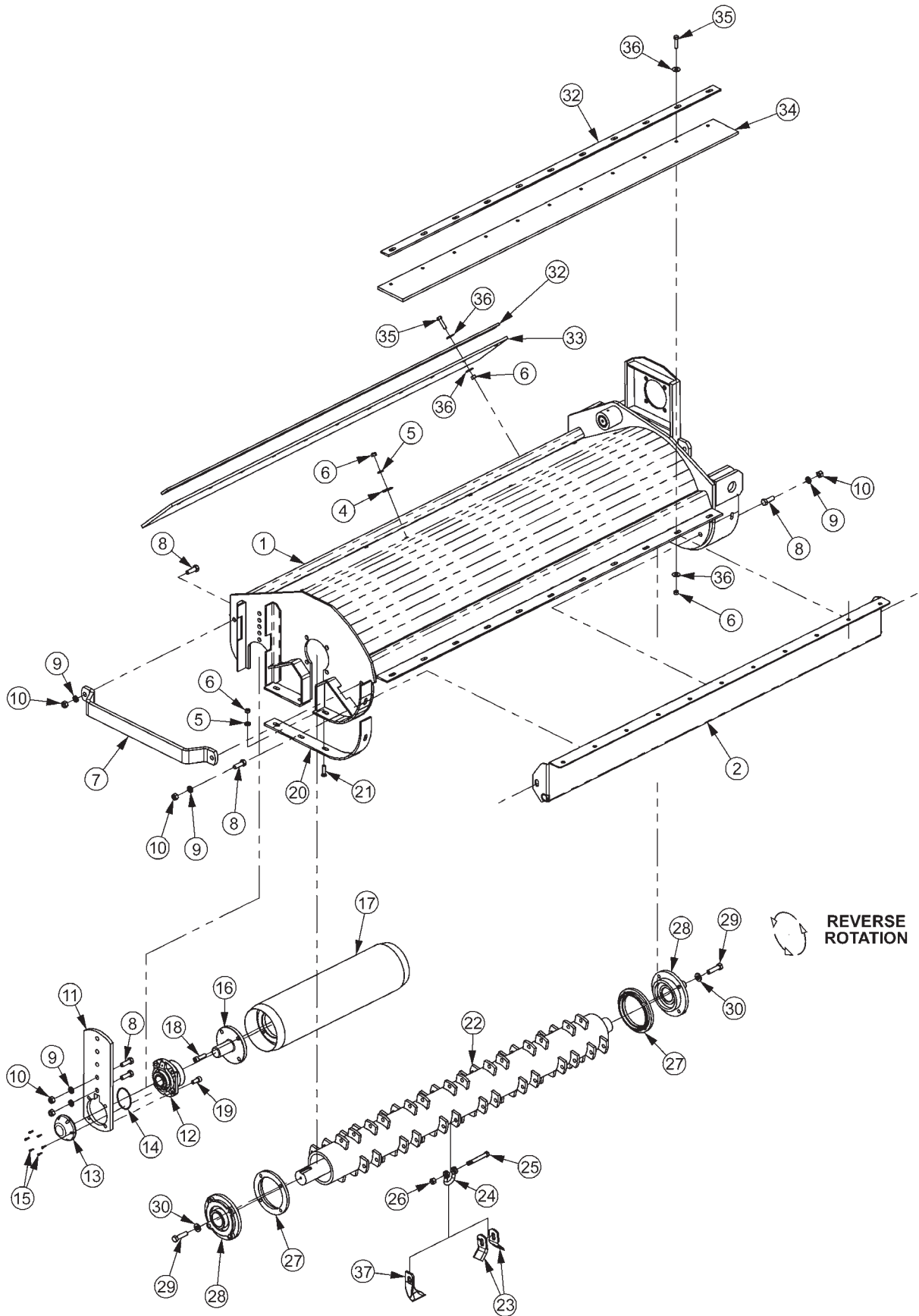

Triple Gang Flail Common Section 6 - 10

STD DUTY 63" SIDE FLAIL, REVERSE ROTATION

ITEM	P/N	QTY	DESCRIPTION
1	32433	1	BONNET,63,STD,T3F,RH (RIGHT FLAIL)
	32224	1	BONNET,63,STD,T3F,LH (LEFT FLAIL)
2	28969A	1	TRASH GUARD,63REV ROT-STD
3	6T2283	8	CARRIAGE BOLT,3/8 X 1 NC
4	6T2615	8	WASHER,FENDER 3/8
5	21988	18	LOCKWASHER,3/8
6	21625	40	HEX NUT,3/8 NC
7	27975A	1	GUARD,CUTTERSCHAFT 5
8	21731	8	CAPSCREW,1/2 X 1-1/2 NC
9	21990	8	LOCKWASHER,1/2
10	21725	8	HEX NUT,1/2 NC
11	28735	2	GROUND ROLLER ADJ BRKT,STD DTY
12	06520028	2	BEARING,FLANGE,1 3/8,GRNDRLR
13	06520027	2	CAP,BEARING,GRNDRLR
14	06520029	2	O-RING,2 3/4x3/32,AS568A-148
15	06530001	12	CAPSCREW,SKT HD,8-32x1/2,SS
16	TF1045B	2	STUB SHAFT,GROUND ROLLER
17	28650A	1	GROUND ROLLER,63
18	6T2330	8	CAPSCREW,SKT HD,7/16X1-1/2NC
19	6T2331	8	CAPSCREW,SKT HD,7/16 X 1 NC
20	28086A	2	SKID SHOE,STD DUTY REAR FLAIL
21	30013	9	PLOW BOLT,3/8 X 1-1/4NC GR5
22	28743	1	CUTTERSCHAFT ASSY,STANDARD (22, 23, 24, 25 & 26)
	28744	1	CUTTERSCHAFT ASSY,SMOOTH (22, 23, 24, 25 & 37)
23	33713	64	FLAIL KNIVES (STANDARD CUT)
24	TF1020	32	KNIFE MTG CLEVIS,FLAIL
25	34011	32	CAPSCREW,7/16x3 7/16,NC GR8
26	21677	32	NYLOCK NUT,7/16 NC
	06200639	*	STRING GUARD KIT, SD (ITEMS 27,29,30)
27	33863	2	STRING GUARD, SD
28	28683	2	BEARING,FLANGE,1-15/16STD TSF
29	06530217	8	CAPSCREW,1/2 X 2,NC,L9
30	06533006	8	FLATWASHER,1/2,SAE,L9
31	21732	2	CAPSCREW,1/2 X 1-3/4 NC
32	28700	2	BAR,FLAP,TSF/TBF 63
33	28701	1	FLAP,DEFLECTOR,TSF 63
34	06520241	1	FLAP,63",FRONT
35	21632	22	CAPSCREW,3/8 X 1-1/2 NC
36	22016	44	FLATWASHER,3/8
37	28184A	32	FLAIL KNIVES (SMOOTH CUT)

STD DUTY 75" SIDE FLAIL, STANDARD ROTATION

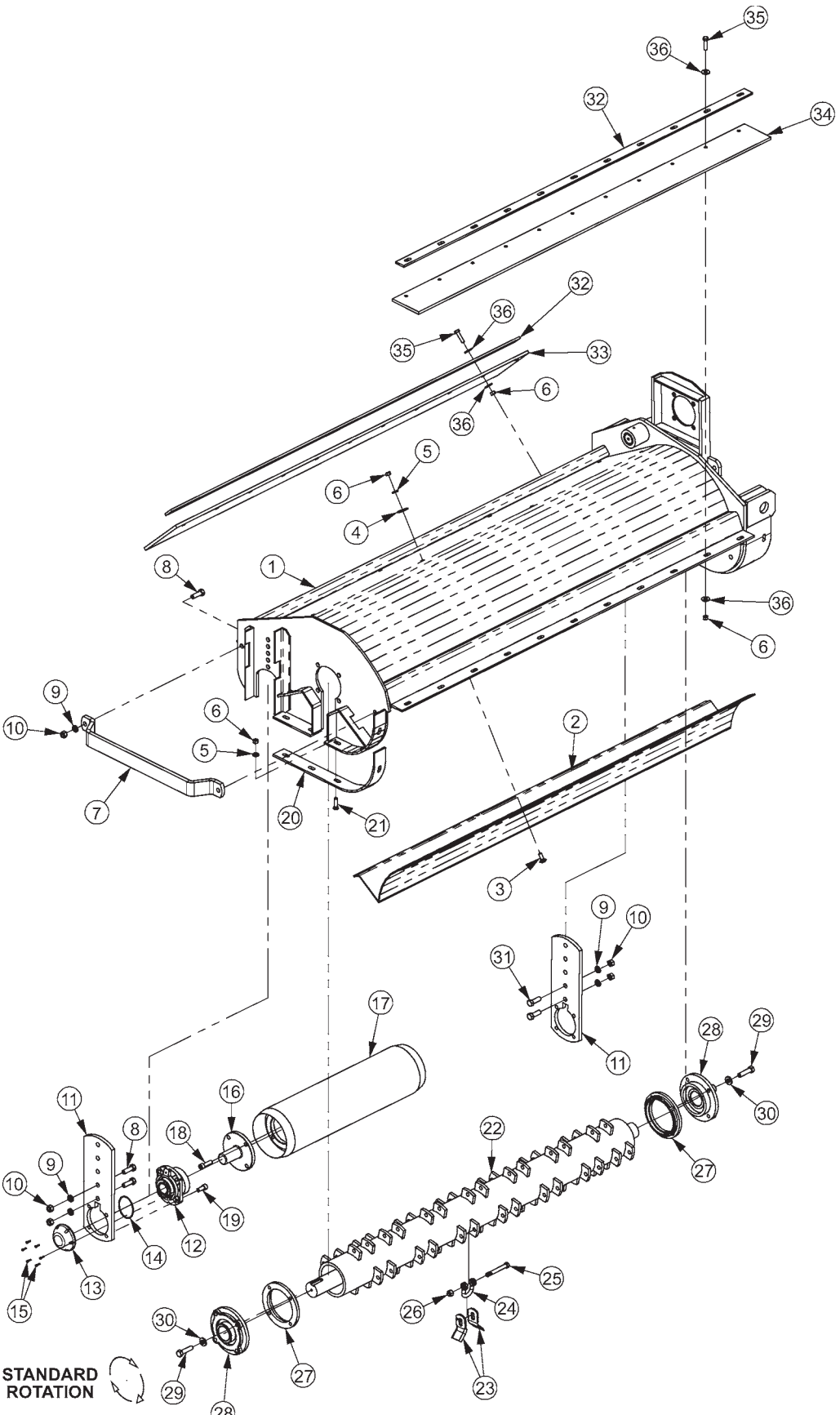

Triple Gang Flail Common Section 6 - 12

STD DUTY 75" SIDE FLAIL, STANDARD ROTATION

ITEM	P/N	QTY	DESCRIPTION
1	06320109	1	BONNET,75,STD,T3F,RT (RIGHT FLAIL)
	06320108	1	BONNET,75,STD,T3F,LT (LEFT FLAIL)
2	28737	1	BAFFLE,75,STD ROT-STD
3	6T2283	8	CARRIAGE BOLT,3/8 X 1 NC
4	6T2615	8	WASHER,FENDER 3/8
5	21988	18	LOCKWASHER,3/8
6	21625	40	HEX NUT,3/8 NC
7	27975A	1	GUARD,CUTTERSHAFT 5
8	21731	4	CAPSCREW,1/2 X 1-1/2 NC
9	21990	6	LOCKWASHER,1/2
10	21725	6	HEX NUT,1/2 NC
11	28735	2	GROUND ROLLER ADJ BRKT,STD DTY
12	06520028	2	BEARING,FLANGE, 1 3/8,GRNDRLR
13	06520027	2	CAP,BEARING,GRNDRLR
14	06520029	2	O-RING,2 3/4x3/32,AS568A-148
15	06530001	12	CAPSCREW,SKT HD,8-32x1/2,SS
16	TF1045B	2	STUB SHAFT,GROUND ROLLER
17	28738	1	GROUND ROLLER,75
18	6T2330	8	CAPSCREW,SKT HD,7/16X1-1/2NC
19	6T2331	8	CAPSCREW,SKT HD,7/16 X 1 NC
20	28086A	2	SKID SHOE,STD DUTY REAR FLAIL
21	30013	9	PLOW BOLT,3/8 X 1-1/4NC GR5
22	28747	1	CUTTERSHAFT ASSY,STANDARD(22, 23, 24, 25 & 26)
23	33713	80	KNIFE,FLAIL,SHORT,FORGES GORCE
24	TF1020	40	KNIFE MTG CLEVIS,FLAIL
25	34011	40	CAPSCREW,7/16x3 7/16,NC GR8
26	21677	40	NYLOCK NUT,7/16 NC
	06200639	*	STRING GUARD KIT, SD (ITEMS 27,29,30)
27	33863	2	STRING GUARD,STD
28	28683	2	BEARING,FLANGE, 1-15/16STD TSF
29	06530217	8	CAPSCREW,1/2 X 2,NC,L9
30	06533006	8	FLATWASHER,1/2,SAE,L9
31	21732	2	CAPSCREW,1/2 X 1-3/4 NC
32	28700	2	BAR,FLAP,TSF/TBF 63
33	28701	1	FLAP,DEFLECTOR,TSF 63
34	06520241	1	FLAP,63",FRONT
35	21632	22	CAPSCREW,3/8 X 1-1/2 NC
36	22016	44	FLATWASHER,3/8

STD DUTY 75" SIDE FLAIL, REVERSE ROTATION

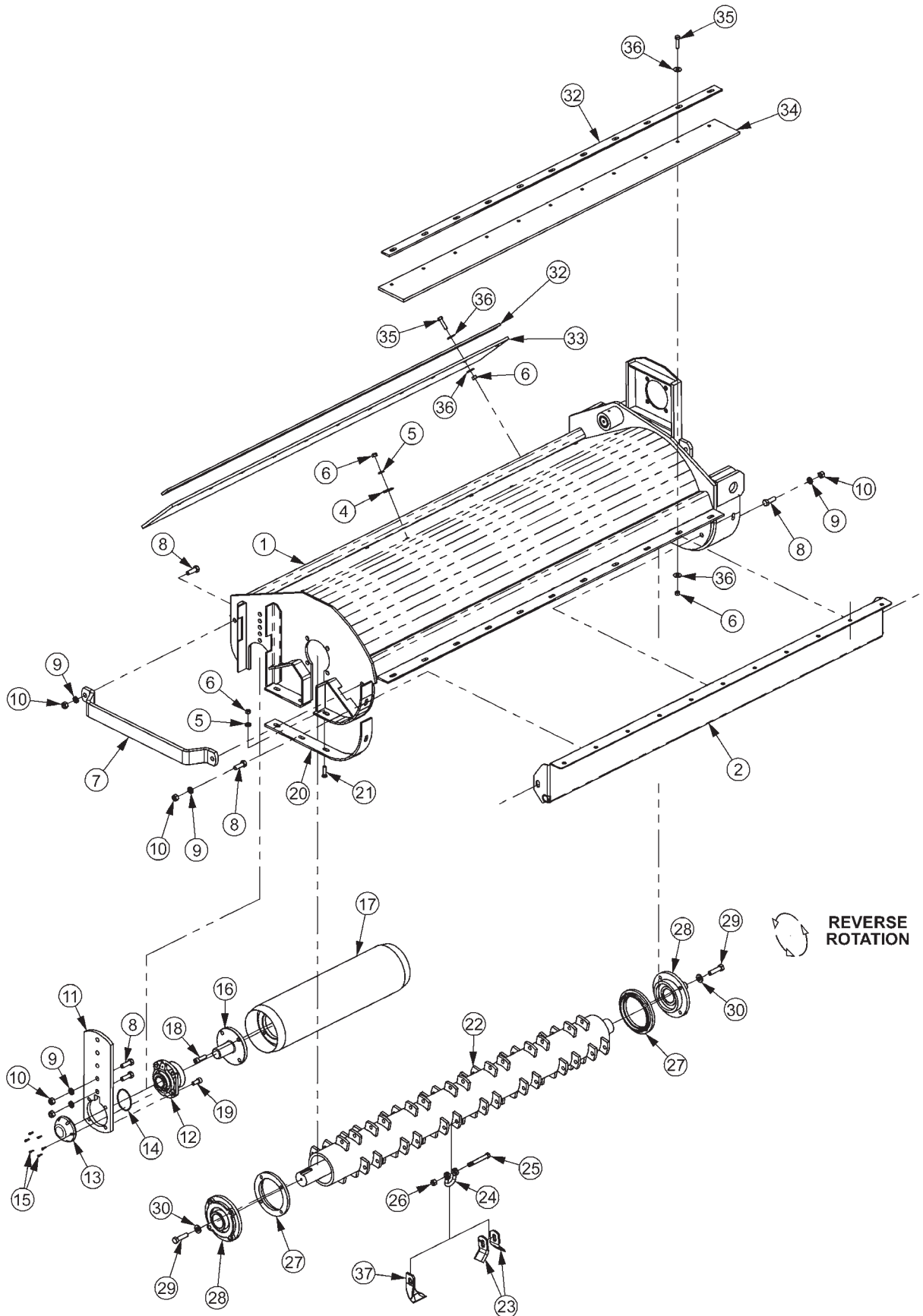

Triple Gang Flail Common Section 6 - 14

STD DUTY 75" SIDE FLAIL REVERSE ROTATION

ITEM	P/N	QTY	DESCRIPTION
1	06320109	1	BONNET,75,STD,T3F,RT (RIGHT FLAIL)
	06320108	1	BONNET,75,STD,T3F,LT (LEFT FLAIL)
2	28969A	1	TRASH GUARD,63REV ROT-STD
3	6T2283	8	CARRIAGE BOLT,3/8 X 1 NC
4	6T2615	8	WASHER,FENDER 3/8
5	21988	18	LOCKWASHER,3/8
6	21625	40	HEX NUT,3/8 NC
7	27975A	1	GUARD,CUTTERSCHAFT 5
8	21731	8	CAPSCREW,1/2 X 1-1/2 NC
9	21990	8	LOCKWASHER,1/2
10	21725	8	HEX NUT,1/2 NC
11	28735	2	GROUND ROLLER ADJ BRKT,STD DTY
12	06520028	2	BEARING,FLANGE,1 3/8,GRNDRLR
13	06520027	2	CAP,BEARING,GRNDRLR
14	06520029	2	O-RING,2 3/4x3/32,AS568A-148
15	06530001	12	CAPSCREW,SKT HD,8-32x1/2,SS
16	TF1045B	2	STUB SHAFT,GROUND ROLLER
17	28738	1	GROUND ROLLER,63
18	6T2330	8	CAPSCREW,SKT HD,7/16X1-1/2NC
19	6T2331	8	CAPSCREW,SKT HD,7/16 X 1 NC
20	28086A	2	SKID SHOE,STD DUTY REAR FLAIL
21	30013	9	PLOW BOLT,3/8 X 1-1/4NC GR5
22	28747	1	CUTTERSCHAFT ASSY,STANDARD (22, 23, 24, 25 & 26)
	28748	1	CUTTERSCHAFT ASSY,SMOOTH (22, 23, 24, 25 & 37)
23	33713	80	FLAIL KNIVES (STANDARD CUT)
24	TF1020	40	KNIFE MTG CLEVIS,FLAIL
25	34011	40	CAPSCREW,7/16x3 7/16,NC GR8
26	21677	40	NYLOCK NUT,7/16 NC
	06200639	*	STRING GUARD KIT, SD (ITEMS 27,29,30)
27	33863	2	STRING GUARD,STD
28	28683	2	BEARING,FLANGE,1-15/16STD TSF
29	06530217	8	CAPSCREW,1/2 X 2,NC,L9
30	06533006	8	FLATWASHER,1/2,SAE,L9
31	21732	2	CAPSCREW,1/2 X 1-3/4 NC
32	28700	2	BAR,FLAP,TSF/TBF 63
33	28701	1	FLAP,DEFLECTOR,TSF 63
34	06520241	1	FLAP,63",FRONT
35	21632	22	CAPSCREW,3/8 X 1-1/2 NC
36	22016	44	FLATWASHER,3/8
37	28184A	40	FLAIL KNIVES (SMOOTH CUT)

STD DUTY SIDE FLAIL DRIVE ASSEMBLY

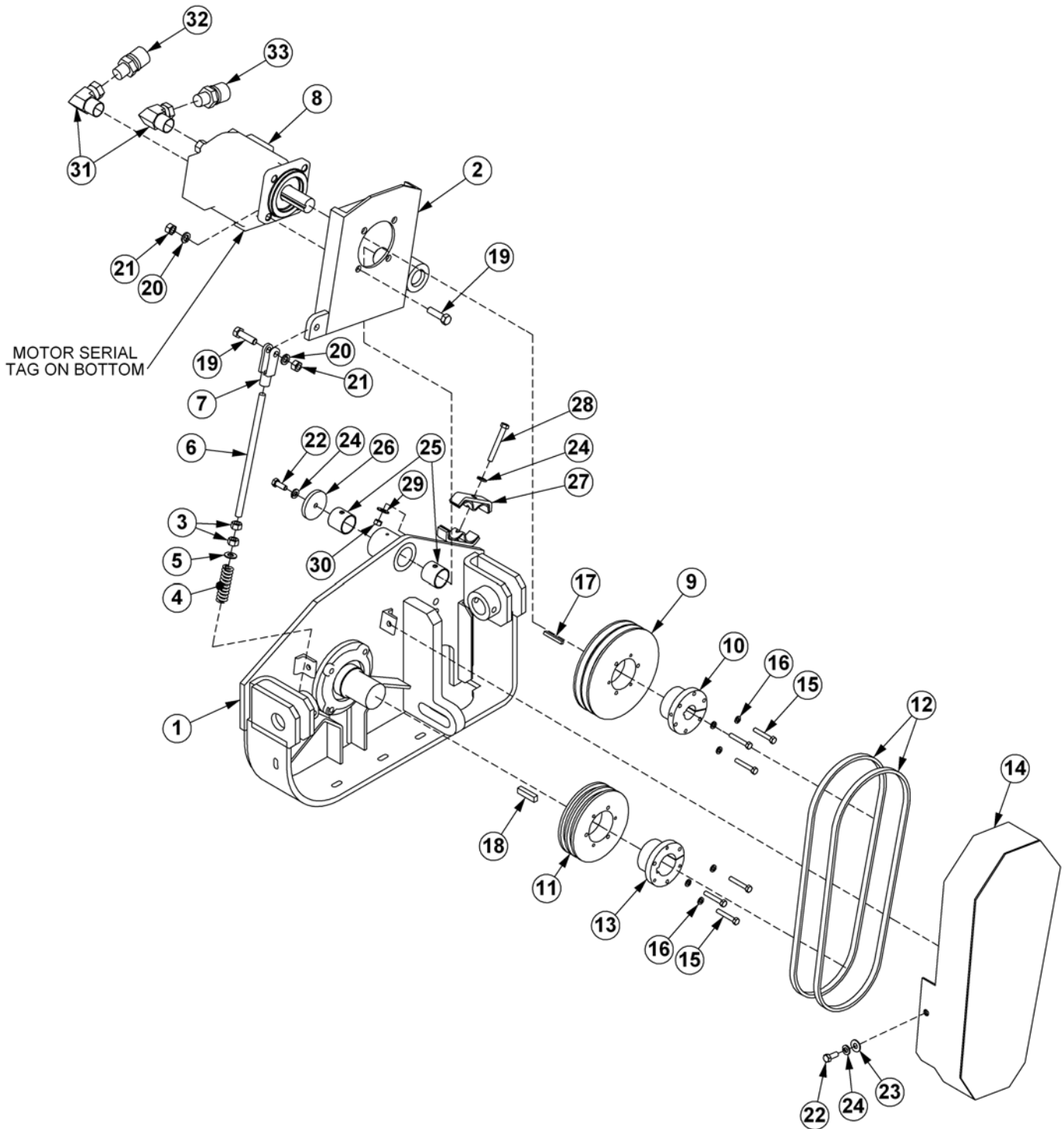

STD DUTY SIDE FLAIL DRIVE ASSEMBLY

ITEM	P/N	QTY	DESCRIPTION
1	REF.	*	BONNET - REFER TO HEAD PARTS
2	32287	1	RIGHT MOTOR MOUNT
	32286	1	LEFT MOTOR MOUNT
3	21700	2	HEX NUT, 1/2", NF
4	TF3620A	1	SPRING,TENSIONER
5	27938	1	BUSHING,MACH,1ODx1/2IDx14GA.
6	40496	1	ROD,THREADED,1/2NFX8
7	PT3611A	1	CLEVIS,6"
8	06504065	1	MOTOR (M350-1 GEAR)
9	TF3041	1	SHEAVE,6.7
10	TF3013	1	BUSHING,QD,SK 1-1/4
11	TF3040	1	SHEAVE,6.3
12	32252	2	V-BELT,(470)
13	28723	1	BUSHING,QD,SK 1-15/16
14	28703B	1	GUARD,BELT,TSF,STD
15	21584	6	CAPSCREW, 5/16 x 2,NC
16	21987	6	LOCKWASHER, 5/16"
17	06504028	1	KEY (KEY FROM MOTOR)
18	26142A	1	KEY,1/2 X 1/2 X 2
19	21732	5	CAPSCREW, 1/2 x 1 3/4,NC
20	21990	5	LOCKWASHER, 1/2"
21	21725	5	HEX NUT,1/2 NC
22	21630	3	CAPSCREW, 3/8 x 1,NC
23	22016	2	FLATWASHER,3/8"
24	21988	4	LOCKWASHER, 3/8"
25	27580	2	BEARING,DX,1-1/2",GRM
26	28682	1	RETAINING,WASHER 2-1/2 X 5/16
27	TB3031	1	HOSE CLAMP
28	21638	1	CAPSCREW,3/8 x 3,NC
29	22016	1	FLATWASHER,3/8
30	21625	1	HEX NUT,3/8,NC
31	34117	2	ELBOW,1MOR x 1MJIC
32	*	REF	HOSE (RETURN FOR STANDARD ROTATION)
33	*	REF	HOSE (PRESSURE FOR STANDARD ROTATION)

HEAVY DUTY 75" SIDE FLAIL, STANDARD ROTATION

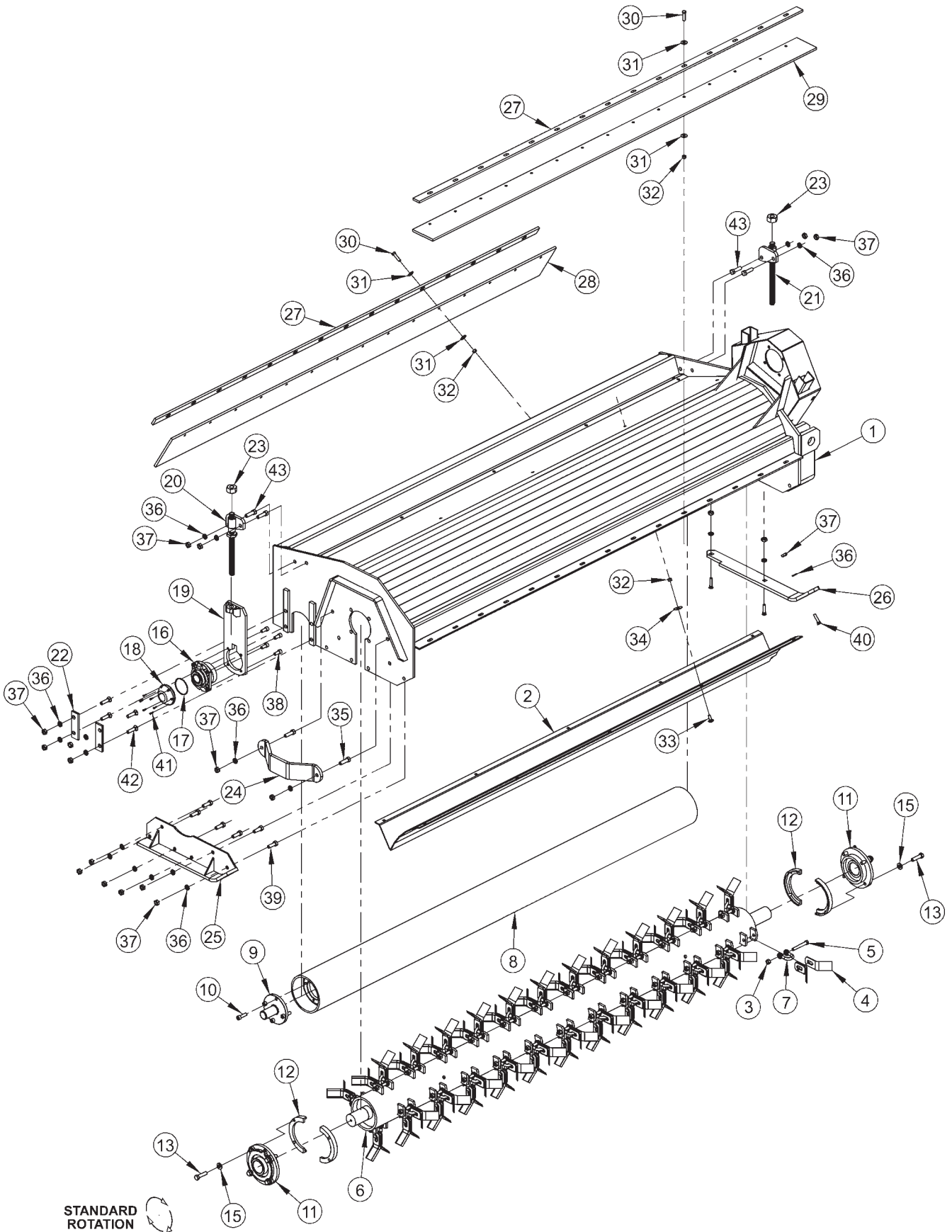

Triple Gang Flail Common Section 6 - 18

HEAVY DUTY 75" SIDE FLAIL, STANDARD ROTATION

ITEM	P/N	QTY	DESCRIPTION
1	21499A	1	BONNET,75,HD,T3F,RT (RIGHT)
1	21478A	1	BONNET,75,HD,T3F,LF
2	TF1402A	1	BAFFLE,FLAIL,75HD,STD ROT
	TF1002A	1	CUTSHFT ASSY,75HD,STD KNIVES
3	21677	40	NYLOCK NUT,7/16 NC
4	33714	80	KNIFE,FLAIL,STANDARD
5	34011	40	CAPSCREW,7/16x3 7/16,NC GR8
6	TF1002	1	CUTTERSHAFT,90,HD
7	TF1020	40	KNIFE MTG CLEVIS,FLAIL
8	28738	1	GROUND ROLLER,75
9	TF1045B	2	STUB SHAFT,GROUND ROLLER
10	6T2330	8	CAPSCREW,SKT HD,7/16X1-1/2NC
11	TF1018	2	BEARING,FLANGE,2-3/16
	06200347	*	STRING GUARD,KIT,HD(ITEMS 12,13,15)
12	31204	2	STRING GUARD, HD
13	06530217	8	CAPSCREW,1/2 X 2,NC,L9
15	06533006	12	FLATWASHER,1/2,SAE,L9
16	06520028	2	BEARING,FLANGE,1 3/8,GRNDRLR
17	06520029	2	O-RING,2 3/4x3/32,AS568A-148
18	06520027	2	CAP,BEARING,GRNDRLR
19	TF4333A	2	GROUND ROLLER ADJ,BRKT
20	TF4334	1	ROD,GROUND ROLLER ADJ,RT
21	TF4335	1	ROD,GROUND ROLLER ADJ,LF
22	TF4336	4	PLATE,GROUND ROLLER LOCK
23	21399	2	HEX NUT,3/4 (ACME) BULK
24	TF1040	1	GUARD,CUTTER SHAFT
25	TF4371	1	SKID SHOE,L/PROFILE-OUTER-(RIGHT)
25	TF4370	1	SKID SHOE,L/PROFILE-OUTER-(LEFT)
26	23272A	1	SKID SHOE,T3F,INNER (RIGHT)
26	27526	1	SKID SHOE,T3F,INNER LEFT,W/STE(LEFT)
27	TF1029	2	BAR,FLAP,TSF/TRF 75
28	TF1016	1	FLAP,DEFLECTOR,TSF/TRF 75
29	06520242	1	FLAP,75",FRONT
30	21632	30	CAPSCREW,3/8 X 1-1/2 NC
31	22016	60	FLATWASHER,3/8
32	21625	40	HEX NUT,3/8 NC
33	6T2283	10	CARRIAGE BOLT,3/8 X 1 NC
34	6T2615	10	WASHER,FENDER 3/8
35	21732	2	CAPSCREW,1/2 X 1-3/4 NC
36	21990	23	LOCKWASHER,1/2
37	21725	23	HEX NUT,1/2 NC
38	6T2331	8	CAPSCREW,SKT HD,7/16 X 1 NC
39	21730	6	CAPSCREW,1/2 X 1-1/4 NC
40	23293	3	PLOW,BOLT,1/2 X 1-3/4 NC
41	06530001	12	CAPSCREW,SKT HD,8-32x1/2,SS
42	6T2291	8	PLOW BOLT,1/2 X 2 NC GR5
43	21731	4	CAPSCREW,1/2 X 1-1/2 NC
**	33608	1	SAFETY STEP PLATE
**	33613	1	SAFETY STEP PLATE

HEAVY DUTY 75" SIDE FLAIL, REVERSE ROTATION

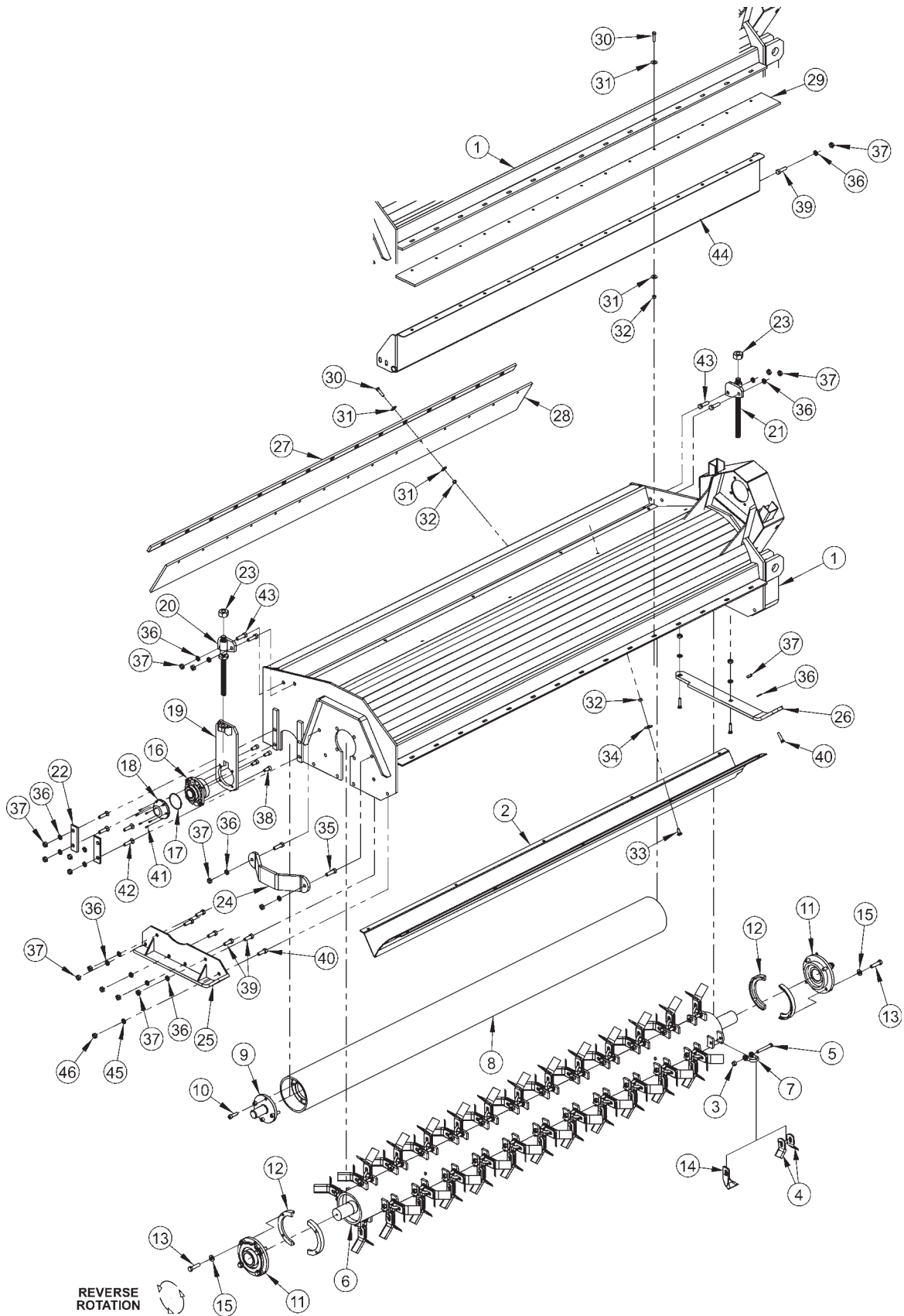

HEAVY DUTY 75" SIDE FLAIL REVERSE ROTATION

ITEM	P/N	QTY	DESCRIPTION
1	21499A	1	BONNET,75,HD,T3F,RT (RIGHT)
1	21478A	1	BONNET,75,HD,T3F,LF (LEFT)
2	TF1402A	1	BAFFLE,FLAIL,75HD (STANDARD ROTATION ONLY)
	TF1002A	1	CUTSHFT ASSY,75HD,STD KNIVE
3	21677	40	NYLOCK NUT,7/16 NC
4	33714	80	KNIFE,FLAIL,STANDARD
5	34011	40	CAPSCREW,7/16x3 7/16,NC GR8
6	TF1002	1	CUTTERSHAFT,75,HD
7	TF1020	40	KNIFE MTG CLEVIS,FLAIL
8	28738	1	GROUND ROLLER,75
9	TF1045B	2	STUB SHAFT,GROUND ROLLER
10	6T2330	8	CAPSCREW,SKT HD,7/16X1-1/2NC
11	TF1018	2	BEARING,FLANGE,2-3/16
	06200347	*	STRING GUARD,KIT,HD(ITEMS 12,13,15)
12	31204	2	STRING GUARD, HD
14	TF1019F	40	KNIFE,FLAIL (SMOOTH CUT)
13	06530217	8	CAPSCREW,1/2 X 2,NC,L9
15	06533006	12	FLATWASHER,1/2,SAE,L9
16	06520028	2	BEARING,FLANGE,1 3/8,GRNDRRLR
17	06520029	2	O-RING,2 3/4x3/32,AS568A-148
18	06520027	2	CAP,BEARING,GRNDRRLR
19	TF4333A	2	GROUND ROLLER ADJ,BRKT
20	TF4334	1	ROD,GROUND ROLLER ADJ,RT
21	TF4335	1	ROD,GROUND ROLLER ADJ,LF
22	TF4336	4	PLATE,GROUND ROLLER LOCK
23	21399	2	HEX NUT,3/4 (ACME) BULK
24	TF1040	1	GUARD,CUTTER SHAFT
25	TF4371	1	SKID SHOE,L/PROFILE-OUTER-(RIGHT)
25	TF4370	1	SKID SHOE,L/PROFILE-OUTER-(LEFT)
26	23272A	1	SKID SHOE,T3F,INNER (RIGHT)
26	27526	1	SKID SHOE,T3F,INNER LEFT,W/STE(LEFT)
27	TF1029	1	BAR,FLAP,TSF/TRF 75
28	TF1016	1	FLAP,DEFLECTOR,TSF/TRF 75
29	06520242	1	FLAP,75",FRONT
30	21632	30	CAPSCREW,3/8 X 1-1/2 NC
31	22016	60	FLATWASHER,3/8
32	21625	40	HEX NUT,3/8 NC
33	6T2283	10	CARRIAGE BOLT,3/8 X 1 NC
34	6T2615	10	WASHER,FENDER 3/8
35	21732	2	CAPSCREW,1/2 X 1-3/4 NC
36	21990	23	LOCKWASHER,1/2
37	21725	23	HEX NUT,1/2 NC
38	6T2331	8	CAPSCREW,SKT HD,7/16 X 1 NC
39	21730	6	CAPSCREW,1/2 X 1-1/4 NC
40	23293	3	PLOW,BOLT,1/2 X 1-3/4 NC
41	06530001	12	CAPSCREW,SKT HD,8-32x1/2,SS
42	6T2291	8	PLOW BOLT,1/2 X 2 NC GR5
43	21731	4	CAPSCREW,1/2 X 1-1/2 NC
44	TF1403	1	TRASH GUARD,75REV ROT-HD
45	22018	1	FLATWASHER,1/2,WIDE
46	21727	1	NYLOCK NUT,1/2 NC
**	33608	1	SAFETY STEP PLATE
**	33613	1	SAFETY STEP PLATE

HEAVY DUTY 90" SIDE FLAIL, STANDARD ROTATION

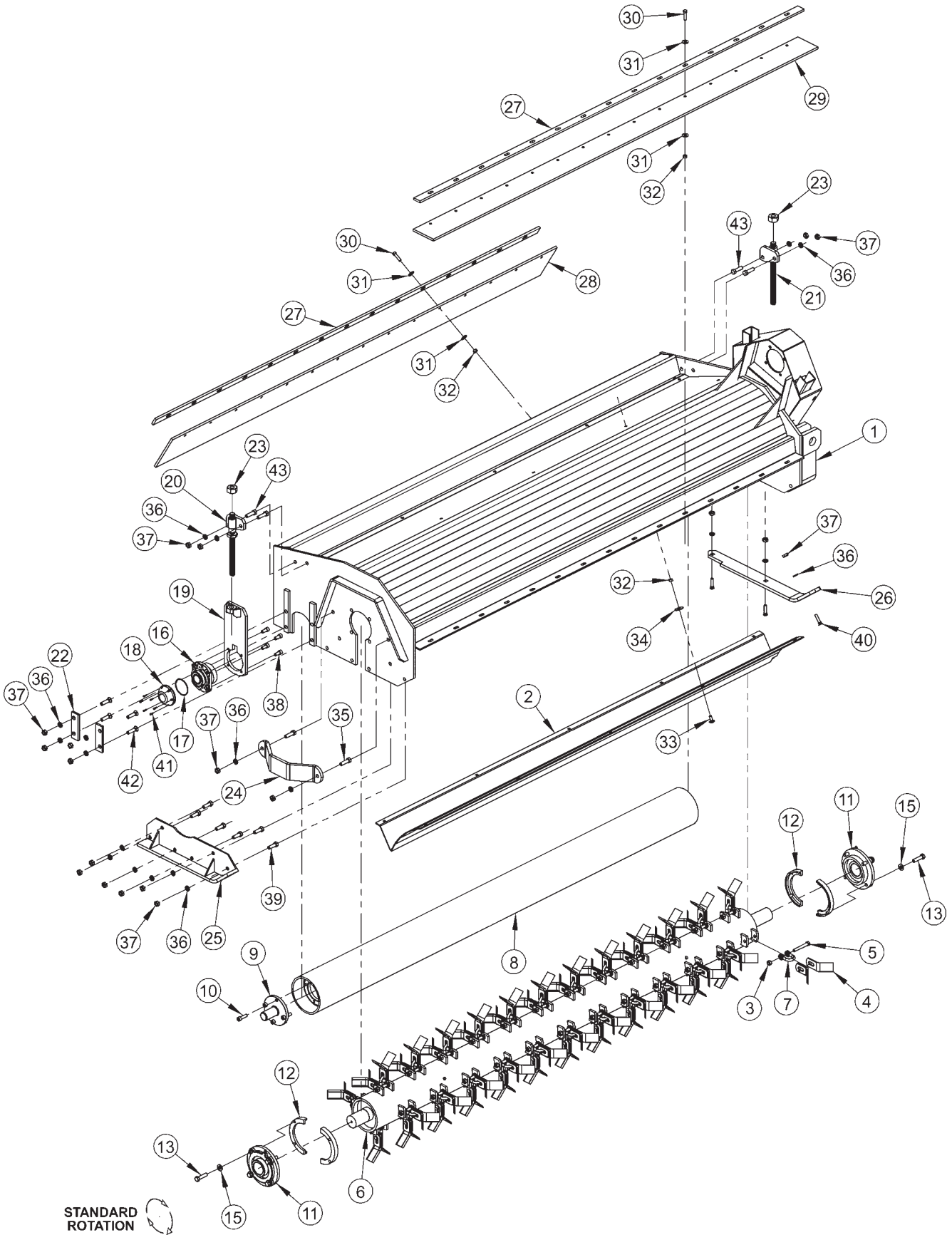

Triple Gang Flail Common Section 6 - 22

HEAVY DUTY 90" SIDE FLAIL, STANDARD ROTATION

ITEM	P/N	QTY	DESCRIPTION
1	22083A	1	BONNET,90,HD,T3F,RT (RIGHT)
1	22084A	1	BONNET 90" T3F (LEFT)
2	TF1502A	1	BAFFLE,FLAIL,90HD,STD ROT
	TF1102A	1	CUTSHFT ASSY,90HD,STD KNIVES
3	21677	48	NYLOCK NUT,7/16 NC
4	33714	96	KNIFE,FLAIL,STANDARD
5	34011	48	CAPSCREW,7/16x3 7/16,NC GR8
6	TF1102	1	CUTTERSHAFT,90,HD
7	TF1020	48	KNIFE MTG CLEVIS,FLAIL
8	27972A	1	GROUND ROLLER,90
9	TF1045B	2	STUB SHAFT,GROUND ROLLER
10	6T2330	8	CAPSCREW,SKT HD,7/16X1-1/2NC
11	TF1018	2	BEARING,FLANGE,2-3/16
	06200347	*	STRING GUARD,KIT,HD(ITEMS 12,13,15)
12	31204	2	STRING GUARD, HD
13	06530217	8	CAPSCREW,1/2 X 2,NC,L9
15	06533006	12	FLATWASHER,1/2,SAE,L9
16	06520028	2	BEARING,FLANGE,1 3/8,GRNDRLR
17	06520029	2	O-RING,2 3/4x3/32,AS568A-148
18	06520027	2	CAP,BEARING,GRNDRLR
19	TF4333A	2	GROUND ROLLER ADJ,BRKT
20	TF4334	1	ROD,GROUND ROLLER ADJ,RT
21	TF4335	1	ROD,GROUND ROLLER ADJ,LF
22	TF4336	4	PLATE,GROUND ROLLER LOCK
23	21399	2	HEX NUT,3/4 (ACME) BULK
24	TF1040	1	GUARD,CUTTER SHAFT
25	TF4371	1	SKID SHOE,L/PROFILE-OUTER-(RIGHT)
25	TF4370	1	SKID SHOE,L/PROFILE-OUTER-(LEFT)
26	23272A	1	SKID SHOE,T3F,INNER (RIGHT)
26	27526	1	SKID SHOE,T3F,INNER LEFT,W/STE(LEFT)
27	TF1135	2	BAR,FLAP,TSF/TRF 90
28	TF1116	1	FLAP,DEFLECTOR,TSF/TRF 90
29	06520243	1	FLAP,90",FRONT
30	21632	30	CAPSCREW,3/8 X 1-1/2 NC
31	22016	60	FLATWASHER,3/8
32	21625	40	HEX NUT,3/8 NC
33	6T2283	10	CARRIAGE BOLT,3/8 X 1 NC
34	6T2615	10	WASHER,FENDER 3/8
35	21732	2	CAPSCREW,1/2 X 1-3/4 NC
36	21990	23	LOCKWASHER,1/2
37	21725	23	HEX NUT,1/2 NC
38	6T2331	8	CAPSCREW,SKT HD,7/16 X 1 NC
39	21730	6	CAPSCREW,1/2 X 1-1/4 NC
40	23293	3	PLOW,BOLT,1/2 X 1-3/4 NC
41	06530001	12	CAPSCREW,SKT HD,8-32x1/2,SS
42	6T2291	8	PLOW BOLT,1/2 X 2 NC GR5
43	21731	4	CAPSCREW,1/2 X 1-1/2 NC
**	33608	1	SAFETY STEP PLATE
**	33613	1	SAFETY STEP PLATE

HEAVY DUTY 90" SIDE FLAIL, REVERSE ROTATION

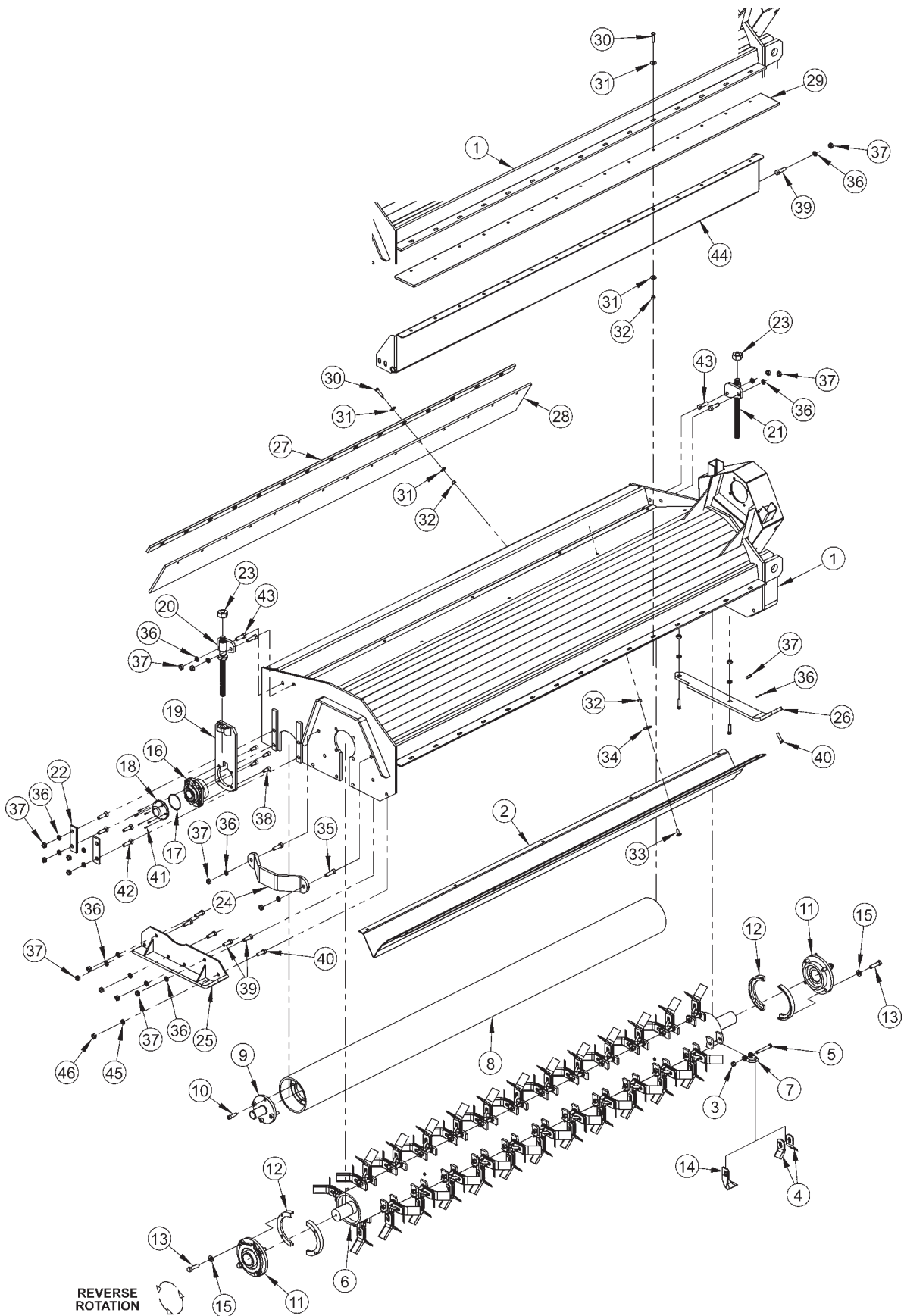

Triple Gang Flail Common Section 6 - 24

HEAVY DUTY 90" SIDE FLAIL, REVERSE ROTATION

ITEM	P/N	QTY	DESCRIPTION
1	22083A	1	BONNET,90,HD,T3F,RT (RIGHT)
1	22084A	1	BONNET 90" T3F (LEFT)
2	TF1502A	1	BAFFLE,FLAIL,90HD (STANDARD ROTATION ONLY)
	TF1102A	1	CUTSHFT ASSY,90HD,STD KNIVES
3	21677	48	NYLOCK NUT,7/16 NC
4	33714	96	KNIFE,FLAIL,STANDARD
5	34011	48	CAPSCREW,7/16x3 7/16,NC GR8
6	TF1102	1	CUTTERSHAFT,90,HD
7	TF1020	48	KNIFE MTG CLEVIS,FLAIL
8	27972A	1	GROUND ROLLER,90
9	TF1045B	2	STUB SHAFT,GROUND ROLLER
10	6T2330	8	CAPSCREW,SKT HD,7/16X1-1/2NC
11	TF1018	2	BEARING,FLANGE,2-3/16
	06200347	*	STRING GUARD,KIT,HD (ITEMS 12,13,15)
12	31204	2	STRING GUARD, HD
13	06530217	8	CAPSCREW,1/2 X 2,NC,L9
14	TF1019F	48	KNIFE,FLAIL (SMOOTH CUT)
15	06533006	12	FLATWASHER,1/2,SAE,L9
16	06520028	2	BEARING,FLANGE,1 3/8,GRNDRLR
17	06520029	2	O-RING,2 3/4x3/32,AS568A-148
18	06520027	2	CAP,BEARING,GRNDRLR
19	TF4333A	2	GROUND ROLLER ADJ,BRKT
20	TF4334	1	ROD,GROUND ROLLER ADJ,RT
21	TF4335	1	ROD,GROUND ROLLER ADJ,LF
22	TF4336	4	PLATE,GROUND ROLLER LOCK
23	21399	2	HEX NUT,3/4 (ACME) BULK
24	TF1040	1	GUARD,CUTTER SHAFT
25	TF4371	1	SKID SHOE,L/PROFILE-OUTER-(RIGHT)
25	TF4370	1	SKID SHOE,L/PROFILE-OUTER-(LEFT)
26	23272A	1	SKID SHOE,T3F,INNER (RIGHT)
26	27526	1	SKID SHOE,T3F,INNER LEFT,W/STE(LEFT)
27	TF1135	1	BAR,FLAP,TSF/TRF 90
28	TF1116	1	FLAP,DEFLECTOR,TSF/TRF 90
29	06520243	1	FLAP,90",FRONT
30	21632	30	CAPSCREW,3/8 X 1-1/2 NC
31	22016	60	FLATWASHER,3/8
32	21625	40	HEX NUT,3/8 NC
33	6T2283	10	CARRIAGE BOLT,3/8 X 1 NC
34	6T2615	10	WASHER,FENDER 3/8
35	21732	2	CAPSCREW,1/2 X 1-3/4 NC
36	21990	23	LOCKWASHER,1/2
37	21725	23	HEX NUT,1/2 NC
38	6T2331	8	CAPSCREW,SKT HD,7/16 X 1 NC
39	21730	6	CAPSCREW,1/2 X 1-1/4 NC
40	23293	3	PLOW,BOLT,1/2 X 1-3/4 NC
41	06530001	12	CAPSCREW,SKT HD,8-32x1/2,SS
42	6T2291	8	PLOW BOLT,1/2 X 2 NC GR5
43	21731	4	CAPSCREW,1/2 X 1-1/2 NC
44	TF1503	1	TRASH GUARD,90REV ROT-HD
45	22018	1	FLATWASHER,1/2,WIDE
46	21727	1	NYLOCK NUT,1/2 NC
**	33608	1	SAFETY STEP PLATE
**	33613	1	SAFETY STEP PLATE

HEAVY DUTY SIDE FLAIL DRIVE ASSEMBLY

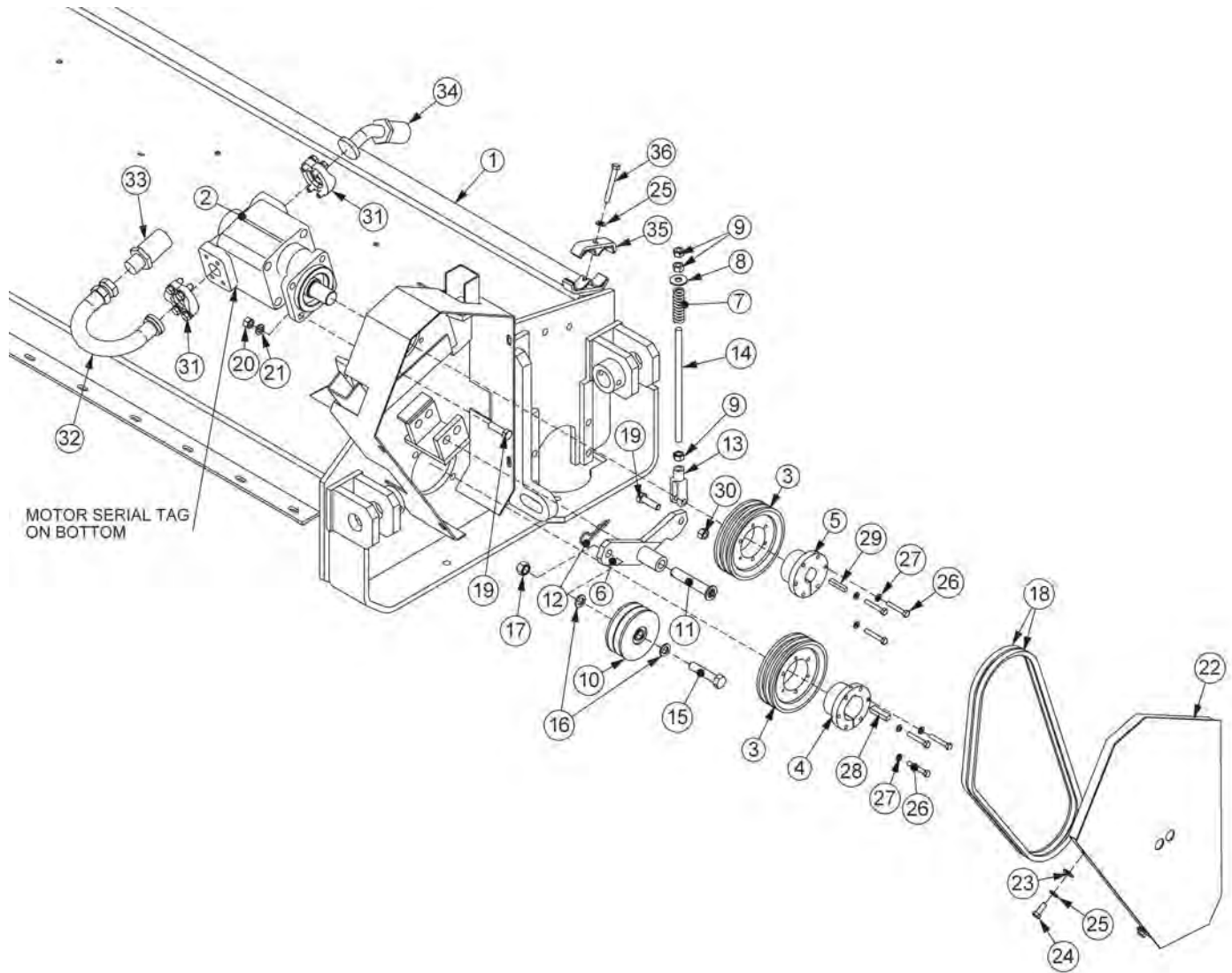

HEAVY DUTY SIDE FLAIL DRIVE ASSEMBLY

ITEM	P/N	QTY	DESCRIPTION
1	*	REF	BONNET - REFER TO FLAIL PARTS
2	06504066	1	MOTOR
3	TF3040	2	SHEAVE,6.3
4	TF3011	1	BUSHING,QD,SK,2-3/16"
5	TF3013	1	BUSHING,QD,SK 1-1/4"(RIGHT)
5	TF3013	1	BUSHING,QD,SK 1-1/4"(LEFT)
6	TF4345	1	IDLER ARM (REVERSE ROTATION / LEFT)
6	TF4346	1	IDLER ARM (STANDARD ROTATION / RIGHT)
7	TF3620A	1	SPRING,TENSIONER
8	22018	1	FLATWASHER,1/2",WIDE
9	21700	3	HEX NUT, 1/2", NF
10	31293	1	SHEAVE,IDLER ASSY, 4.4 O.D.
11	TF3605	1	PIN,IDLER ARM 3/4"X4-1/4"
12	6T3004	1	R-CLIP (HAIRPIN COTTER, 3/16")
13	PT3611A	1	CLEVIS,6"
14	32494	1	ROD, THREADED, 1/2-20NF
15	21787	1	CAPSCREW,5/8" x 3", NC
16	21992	2	LOCKWASHER, 5/8
17	21775	1	HEX NUT, 5/8
18	TF3020	2	V-BELT, (530)
19	21732	5	CAPSCREW, 1/2 x 1 3/4,NC
20	21725	4	HEX NUT, 1/2" NC
21	21990	4	LOCKWASHER, 1/2"
22	TF4564	1	BELT SHEILD (RIGHT)
22	TF4565	1	BELT SHEILD (LEFT)
23	22016	4	FLATWASHER,3/8"
24	21630	4	CAPSCREW, 3/8 x 1,NC
25	21988	5	LOCKWASHER, 3/8"
26	21584	6	CAPSCREW, 5/16 x 2,NC
27	21987	6	LOCKWASHER, 5/16"
28	TF1025	1	KEY,1/4" X 1/2" X 1-7/8" SQ
29	TF1125	1	KEY,3/8" X 1/2" X 1-7/8" SQ
30	21727	1	NYLOCK NUT,1/2,NC
31	TF4853	2	KIT,FLANGE,#16
32	32920	1	PREFORMED TUBE
33	*	REF	HOSE (RETURN FOR STANDARD ROTATION)
34	*	REF	HOSE (PRESSURE FOR STANDARD ROTATION)
35	TB3031	1	HOSE CLAMP
36	21638	1	CAPSCREW,3/8 x 3,NC

STD DUTY 75" REAR FLAIL STANDARD ROTATION

ITEM	P/N	QTY	DESCRIPTION
1	06320134	1	BONNET,75,STD,ROSTA
2	21731	6	CAPSCREW,1/2 x 1-1/2,NC
3	21990	6	LOCKWASHER,1/2
4	21725	6	HEX NUT,1/2,NC
5	27975A	1	GUARD,CUTTERSHAFT
6	TF1029	2	BAR,FLAP,TSF/TRF 75
7	06520242	1	FLAP,75",FRONT
8	21632	20	CAPSCREW,3/8 x 1-1/2,NC
9	22016	81	FLATWASHER,3/8,GR8
10	21625	40	HEX NUT,3/8,NC
11	06530217	8	CAPSCREW,3/4 x 2-1/2,GR8,NC
12	06533006	8	FLATWASHER,1/2,SAE,L9
13	28683	2	BEARING,FLANGE,1-15/16,STD
14	33863	2	STRING GUARD,STD
15	28643B	1	CUTTERSHAFT,75STD,W/EARS
16	6T2283	10	CARRIAGE BOLT,3/8 x 1,NC
17	21677	40	NYLOCK NUT,7/16,NC
18	TF1020	40	KNIFE MTG CLEVIS,FLAIL
19	33713	80	KNIFE,FLAIL,SHORT
20	34011	40	CAPSCREW,7/16 x 3-7/16,GR8,NC
21	TF1033	1	GREASE ZERK,1/8 FPT
22	TF1032	1	GRS HOSE,3/16 x 8
23	28737	1	BAFFLE,75,STD ROT-STD
24	28086A	2	SKID SHOE,STD DUTY,REAR FLAIL
25	30013	10	PLOW BOLT,3/8 x 1-1/4,GR5,NC
26	28738	1	GROUND ROLLER,75
27	TF1045B	2	STUB SHAFT,GROUND ROLLER
28	6T2330	8	CAPSCREW,SKT HD,7/16 x 1-1/2,NC
29	6T2331	4	CAPSCREW,SKT HD,7/16 x 1,NC
30	28735	2	GROUND ROLLER ADJ BRKT,STD DTY
31	06520028	2	BEARING,FLANGE,1-3/8,GRNDRLLR
32	06520029	2	O-RING,2-3/4 x 3/32,AS568A-148
33	06520027	2	CAP,BEARING,GRNDRLLR
34	06530001	12	CAPSCREW,SKT HD,8-32 x 1/2,SS
35	TF1016	1	FLAP,DEFLECTOR,75
36	6T2615	10	WASHER,FENDER,3/8
37	21988	10	LOCKWASHER,3/8

STD DUTY 75" REAR FLAIL REVERSE ROTATION

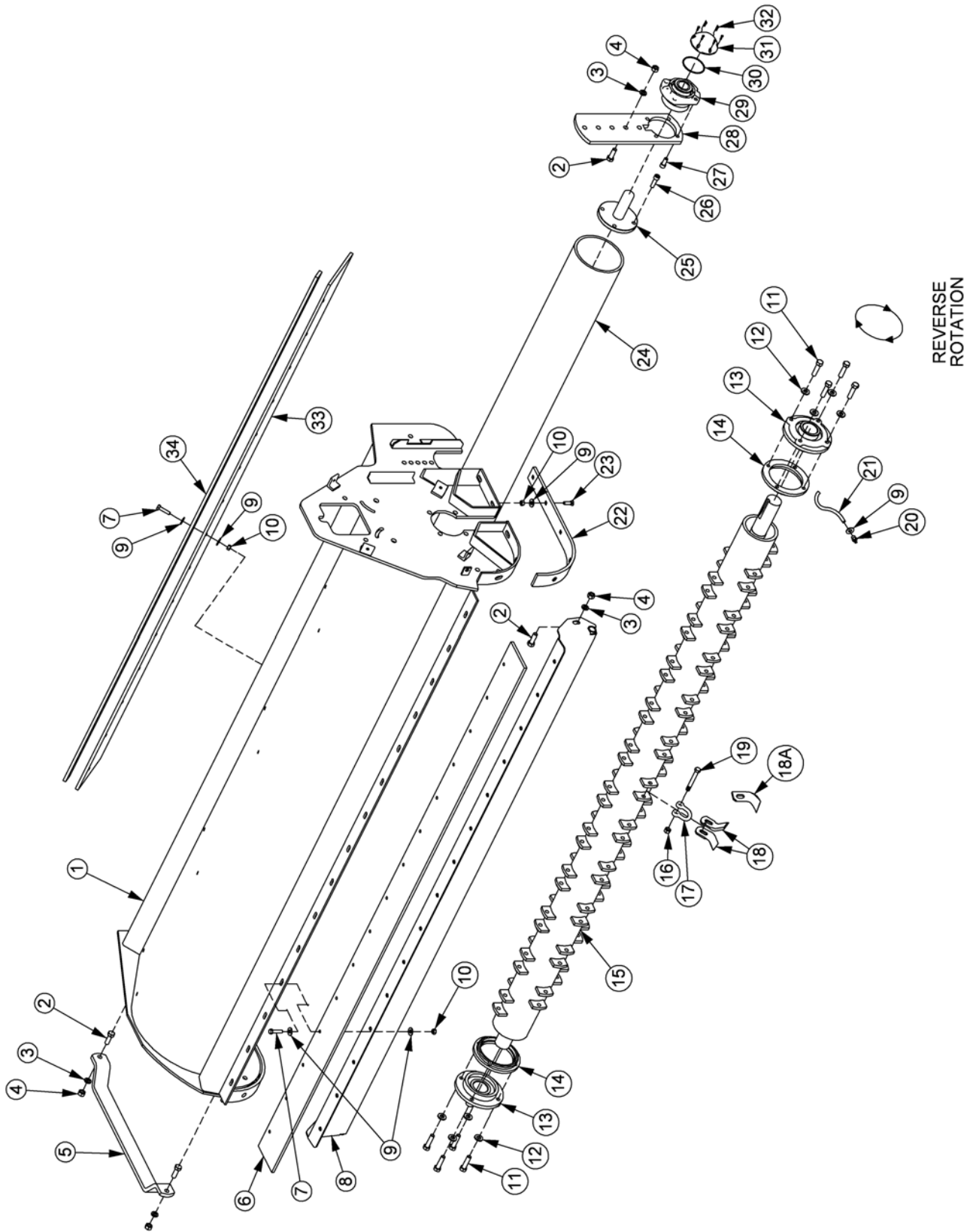

75" REAR FLAIL REVERSE ROTATION

ITEM	P/N	QTY	DESCRIPTION
1	06320134	1	BONNET,75,STD,ROSTA
2	21731	8	CAPSCREW,1/2 x 1-1/2,NC
3	21990	8	LOCKWASHER,1/2
4	21725	8	HEX NUT,1/2,NC
5	27975A	1	GUARD,CUTTERSHAFT
6	06520242	1	FLAP,75",FRONT
7	21632	20	CAPSCREW,3/8 x 1-1/2,NC
8	28968A	1	TRASH GUARD,75"
9	22016	81	FLATWASHER,3/8,GR8
10	21625	40	HEX NUT,3/8,NC
11	06530217	8	CAPSCREW,3/4 x 2-1/2,GR8,NC
12	06533006	8	FLATWASHER,1/2,SAE,L9
13	28683	2	BEARING,FLANGE,1-15/16,STD
14	33863	2	STRING GUARD,STD
15	28643B	1	CUTTERSHAFT,75STD,W/EARS
16	21677	40	NYLOCK NUT,7/16,NC
17	TF1020	40	KNIFE MTG CLEVIS,FLAIL
18	33713	80	KNIFE,FLAIL,SHORT
18A	28184A	40	KNIFE,FLAIL,SMC,STD
19	34011	40	CAPSCREW,7/16 x 3-7/16,GR8,NC
20	TF1033	1	GREASE ZERK,1/8 FPT
21	TF1032	1	GRS HOSE,3/16 x 8
22	28086A	2	SKID SHOE,STD DUTY,REAR FLAIL
23	30013	10	PLOW BOLT,3/8 x 1-1/4,GR5,NC
24	28738	1	GROUND ROLLER,75
25	TF1045B	2	STUB SHAFT,GROUND ROLLER
26	6T2330	8	CAPSCREW,SKT HD,7/16 x 1-1/2,NC
27	6T2331	4	CAPSCREW,SKT HD,7/16 x 1,NC
28	28735	2	GROUND ROLLER ADJ BRKT,STD DTY
29	06520028	2	BEARING,FLANGE,1-3/8,GRNDRLLR
30	06520029	2	O-RING,2-3/4 x 3/32,AS568A-148
31	06520027	2	CAP,BEARING,GRNDRLLR
32	06530001	12	CAPSCREW,SKT HD,8-32 x 1/2,SS
33	TF1016	1	FLAP,DEFLECTOR,75
34	TF1029	2	BAR,FLAP,TSF/TRF,75

STD DUTY 90" REAR FLAIL STANDARD ROTATION

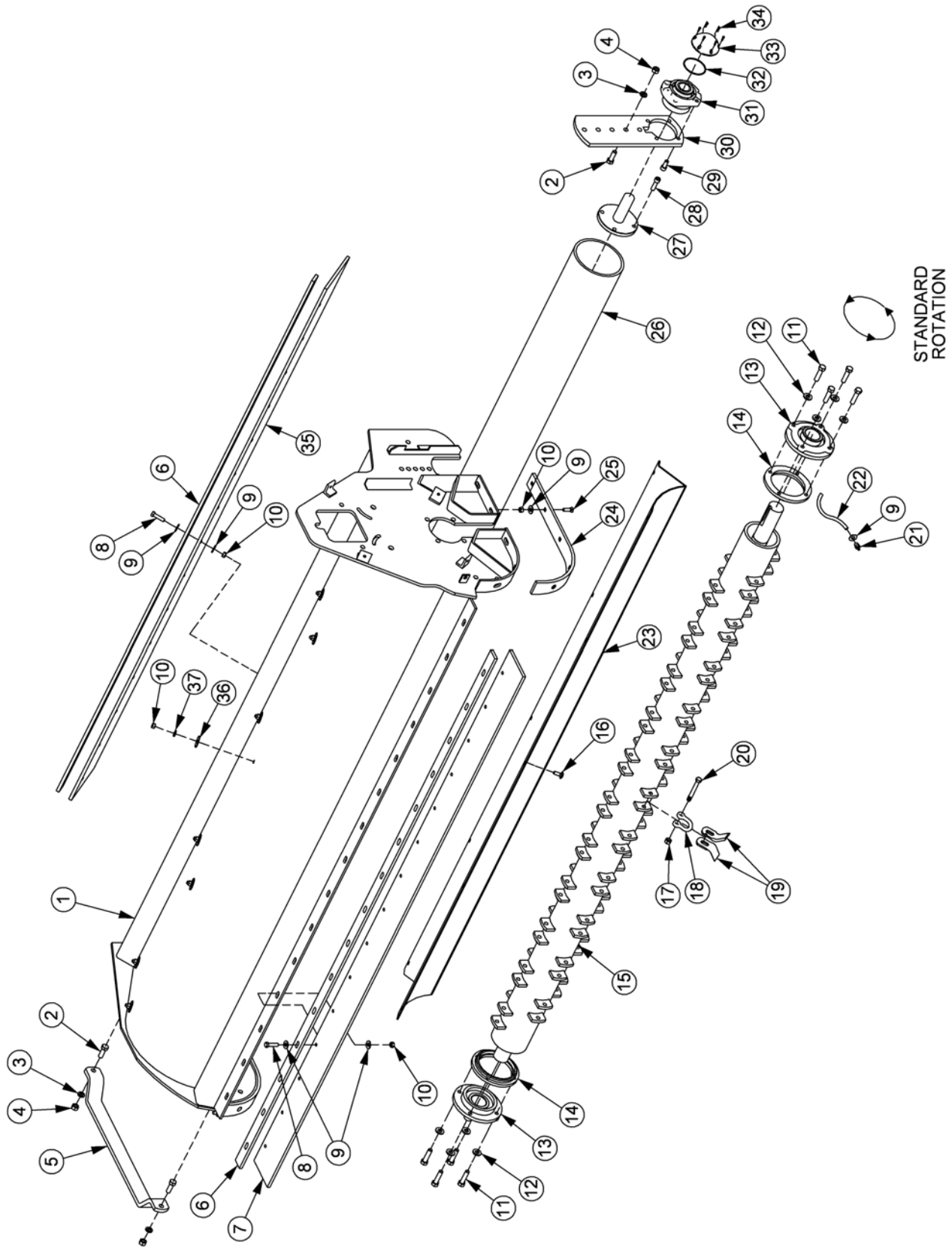

90" REAR FLAIL STANDARD ROTATION

ITEM	P/N	QTY	DESCRIPTION
1	06320115	1	BONNET,90,STD,ROSTA
2	21731	6	CAPSCREW,1/2 x 1-1/2,NC
3	21990	6	LOCKWASHER,1/2
4	21725	6	HEX NUT,1/2,NC
5	27975A	1	GUARD,CUTTERSHAFT
6	TF1135	2	BAR,FLAP,TSF/TRF 90
7	06520243	1	FLAP,90",FRONT
8	21632	20	CAPSCREW,3/8 x 1-1/2,NC
9	22016	81	FLATWASHER,3/8,GR8
10	21625	40	HEX NUT,3/8,NC
11	06530217	8	CAPSCREW,3/4 x 2-1/2,GR8,NC
12	06533006	8	FLATWASHER,1/2,SAE,L9
13	28683	2	BEARING,FLANGE,1-15/16,STD
14	33863	2	STRING GUARD,STD
15	27964C	1	CUTTERSHAFT,90STD,W/EARS
16	6T2283	10	CARRIAGE BOLT,3/8 x 1,NC
17	21677	48	NYLOCK NUT,7/16,NC
18	TF1020	48	KNIFE MTG CLEVIS,FLAIL
19	33713	96	KNIFE,FLAIL,SHORT
20	34011	48	CAPSCREW,7/16 x 3-7/16,GR8,NC
21	TF1033	1	GREASE ZERK,1/8 FPT
22	TF1032	1	GRS HOSE,3/16 x 8
23	27971	1	BAFFLE,90,STD ROT-STD
24	28086A	2	SKID SHOE,STD DUTY,REAR FLAIL
25	30013	10	PLOW BOLT,3/8 x 1-1/4,GR5,NC
26	28738	1	GROUND ROLLER,75
27	TF1045B	2	STUB SHAFT,GROUND ROLLER
28	6T2330	8	CAPSCREW,SKT HD,7/16 x 1-1/2,NC
29	6T2331	4	CAPSCREW,SKT HD,7/16 x 1,NC
30	28735	2	GROUND ROLLER ADJ BRKT,STD DTY
31	06520028	2	BEARING,FLANGE,1-3/8,GRNDRLLR
32	06520029	2	O-RING,2-3/4 x 3/32,AS568A-148
33	06520027	2	CAP,BEARING,GRNDRLLR
34	06530001	12	CAPSCREW,SKT HD,8-32 x 1/2,SS
35	TF1116	1	FLAP,DEFLECTOR,90
36	6T2615	10	WASHER,FENDER,3/8
37	21988	10	LOCKWASHER,3/8

STD DUTY 90" REAR FLAIL REVERSE ROTATION

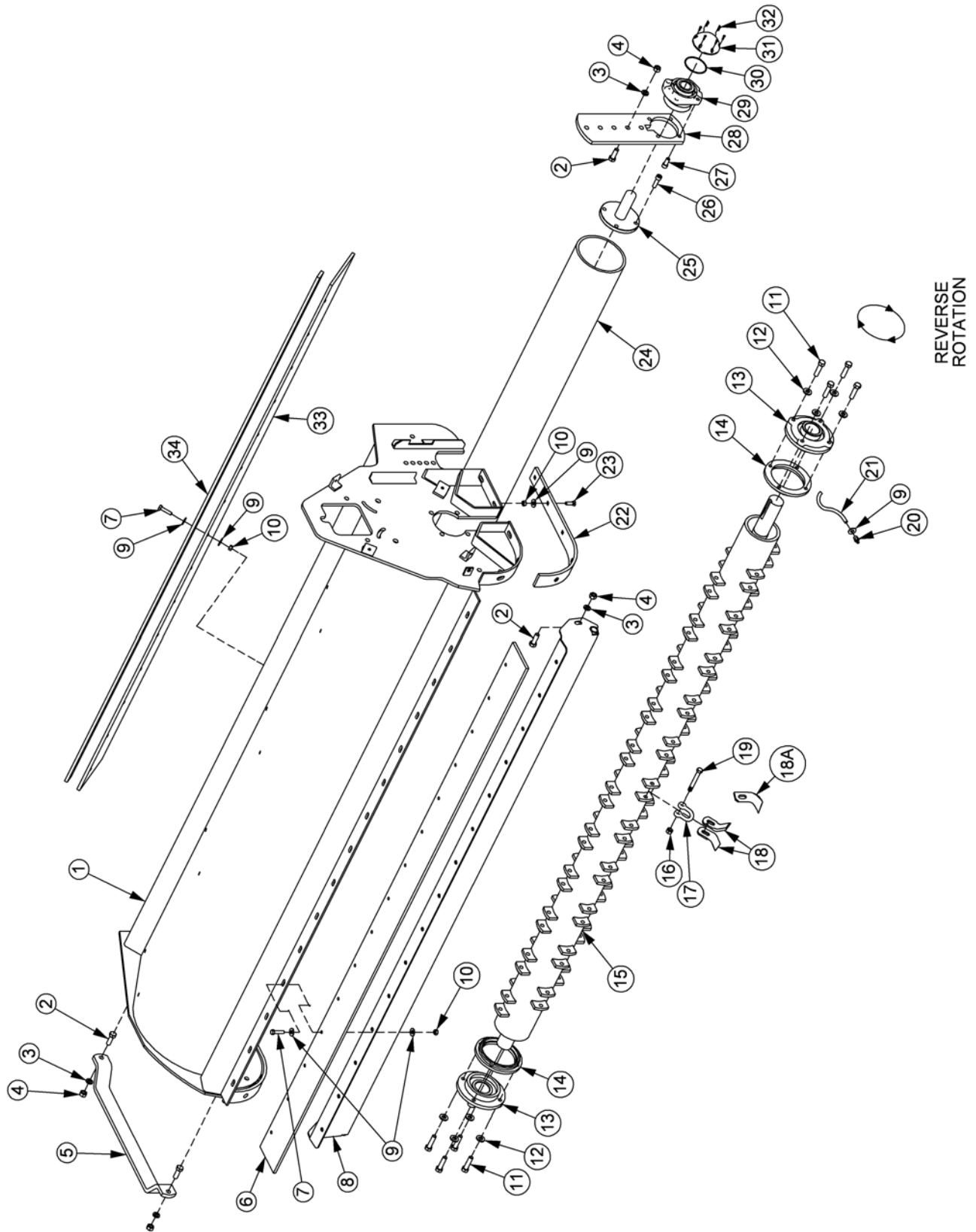

90" REAR FLAIL REVERSE ROTATION

ITEM	P/N	QTY	DESCRIPTION
1	06320115	1	BONNET,90,STD,ROSTA
2	21731	8	CAPSCREW,1/2 x 1-1/2,NC
3	21990	8	LOCKWASHER,1/2
4	21725	8	HEX NUT,1/2,NC
5	27975A	1	GUARD,CUTTERSHAFT
6	06520243	1	FLAP,90",FRONT
7	21632	20	CAPSCREW,3/8 x 1-1/2,NC
8	28967A	1	TRASH GUARD,90"
9	22016	81	FLATWASHER,3/8,GR8
10	21625	40	HEX NUT,3/8,NC
11	06530217	8	CAPSCREW,3/4 x 2-1/2,GR8,NC
12	06533006	8	FLATWASHER,1/2,SAE,L9
13	28683	2	BEARING,FLANGE,1-15/16,STD
14	33863	2	STRING GUARD,STD
15	27964C	1	CUTTERSHAFT,90STD,W/EARS
16	21677	48	NYLOCK NUT,7/16,NC
17	TF1020	48	KNIFE MTG CLEVIS,FLAIL
18	33713	96	KNIFE,FLAIL,SHORT
18A	28184A	48	KNIFE,FLAIL,SMC,STD
19	34011	48	CAPSCREW,7/16 x 3-7/16,GR8,NC
20	TF1033	1	GREASE ZERK,1/8 FPT
21	TF1032	1	GRS HOSE,3/16 x 8
22	28086A	2	SKID SHOE,STD DUTY,REAR FLAIL
23	30013	10	PLOW BOLT,3/8 x 1-1/4,GR5,NC
24	27972A	1	GROUND ROLLER,90
25	TF1045B	2	STUB SHAFT,GROUND ROLLER
26	6T2330	8	CAPSCREW,SKT HD,7/16 x 1-1/2,NC
27	6T2331	4	CAPSCREW,SKT HD,7/16 x 1,NC
28	28735	2	GROUND ROLLER ADJ BRKT,STD DTY
29	06520028	2	BEARING,FLANGE,1-3/8,GRNDRLLR
30	06520029	2	O-RING,2-3/4 x 3/32,AS568A-148
31	06520027	2	CAP,BEARING,GRNDRLLR
32	06530001	12	CAPSCREW,SKT HD,8-32 x 1/2,SS
33	TF1116	1	FLAP,DEFLECTOR,90
34	TF1035	2	BAR,FLAP,TSF/TRF,90

STD DUTY REAR FLAIL DRIVE ASSEMBLY

DRIVE
ORIENTATION

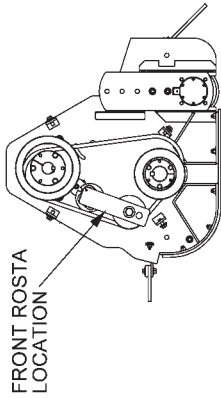

STANDARD ROTATION

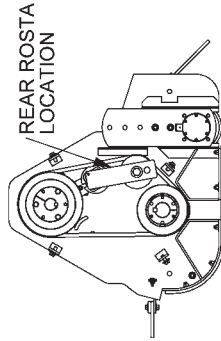

REVERSE ROTATION

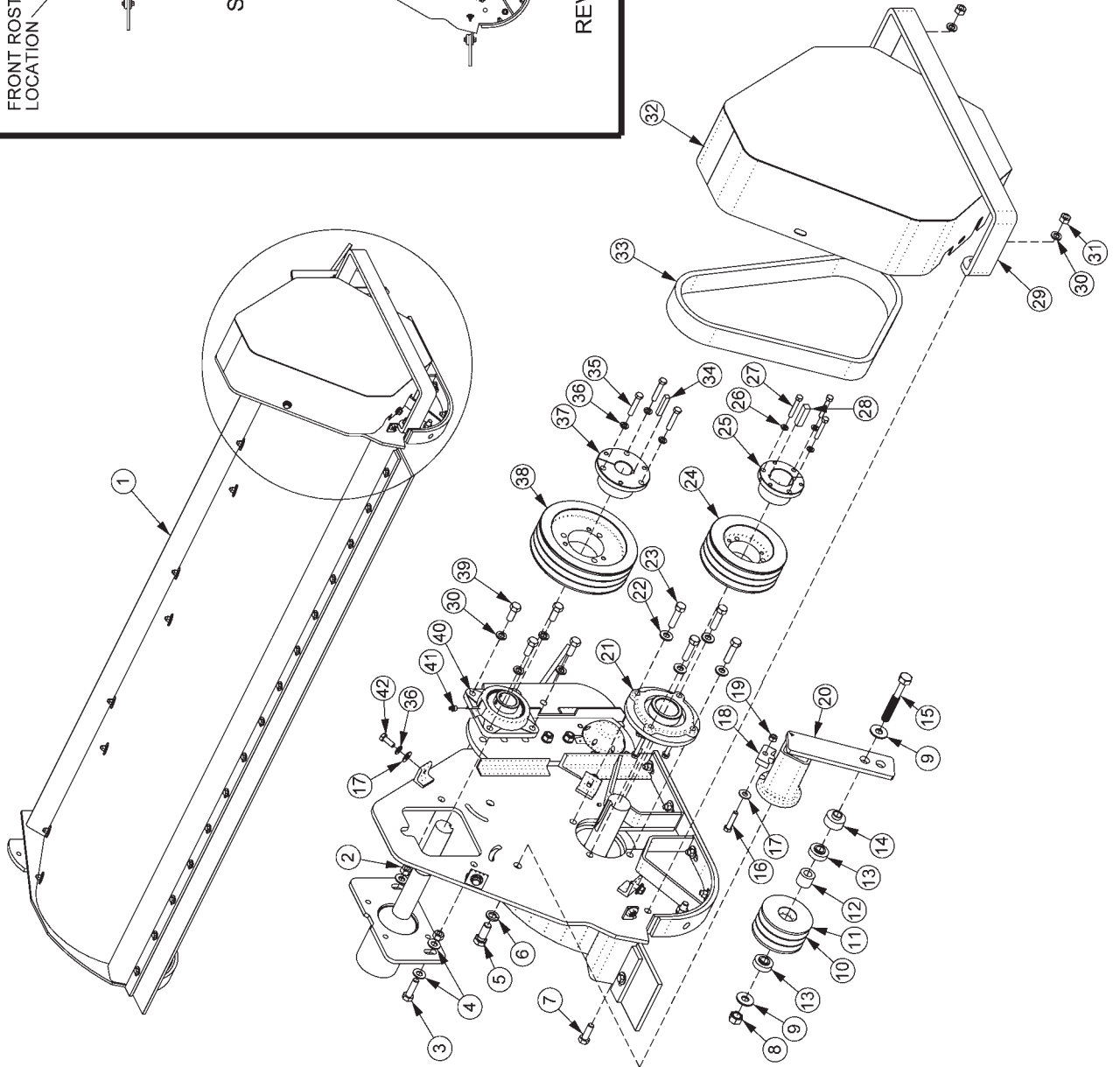

STD DUTY REAR FLAIL DRIVE ASSEMBLY

ITEM	P/N	QTY	DESCRIPTION
1	*	1	BONNET - REFER TO CUTTER ASSEMBLY
2	21727	2	NYLOCK NUT,1/2,NC
3	21732	2	CAPSCREW,1/2 x 1-3/4,NC
4	22018	4	FLATWASHER,1/2,WIDE
5	22421	REF	CAPSCREW,16MM x 40MM(2.0P)
6	31956	REF	FLATWASHER,16MM,HARDENED
7	21731	2	CAPSCREW,1/2 x 1-1/2,NC
8	32838	1	HEX NUT,5/8-11 UNC,GR8
9	25270	2	FLATWASHER,5/8,GR8,USS
10	06700092	REF	ASSY,SHEAVE,IDLER,3 GRV
11	06420072	1	SHEAVE,IDLER,3 GRV
12	31298	2	BRG,FAFNIR,203KRR2
13	06430072	1	SPACER,1.25 x .69 x 1.03
14	06420094	1	SPACER,1.00 x 1.63 x .64
15	33854	1	CAPSCREW,5/8 x 4-1/2,GR8,NC
16	21632	1	CAPSCREW,3/8 x 1-1/2,NC
17	22016	5	FLATWASHER,3/8,GR8
18	06400717	1	STOP,ROSTA
19	21627	1	NYLOCK NUT,3/8,NC
20	06520306	1	TNSNR,ROSTA,SE38,W/MTG BOLT
21	28683	2	BEARING,FLANGE,1-15/16,STD
22	06533006	8	FLATWASHER,1/2,L9,SAE
23	06530217	8	CAPSCREW,1/2 x 2,L9,NC
24	06520218	1	SHEAVE,6.7,3G5V,QD,SK
25	28723	1	BUSHING,QD,SK 1-15/16
26	21987	3	LOCKWASHER,5/16
27	21584	3	CAPSCREW,5/16 x 2,NC
28	26142A	1	KEY,1/2SQ x 2
29	06410723	1	BAR,RUB
30	21990	6	LOCKWASHER,1/2
31	21725	2	HEX NUT,1/2,NC
32	06320114	1	SHIELD,BELT,WLDMNT,STD
33	06520312	1	BELT,BANDED,3/5VX560
34	28224	1	KEY,3/8SQ x 2
35	21634	3	CAPSCREW,3/8 x 2,NC
36	21988	3	LOCKWASHER,3/8
37	06520304	1	BUSHING,QD,SF 1-1/2,3/8 KEY
38	02967325	1	SHEAVE,8.5,3G5V
39	21730	4	CAPSCREW,1/2 x 1-1/4,NC
40	06520308	1	BRNG,FLNG,1-1/2,GRIP-TIGHT
41	6T3208	1	ZERK,1/8 x 45°
42	21630	4	CAPSCREW,3/8 x 1,NC
43	06520286	1	GAGE,TENSION,PLUNGER (NOT SHOWN)

STD DUTY PTO DRIVE ASSEMBLY

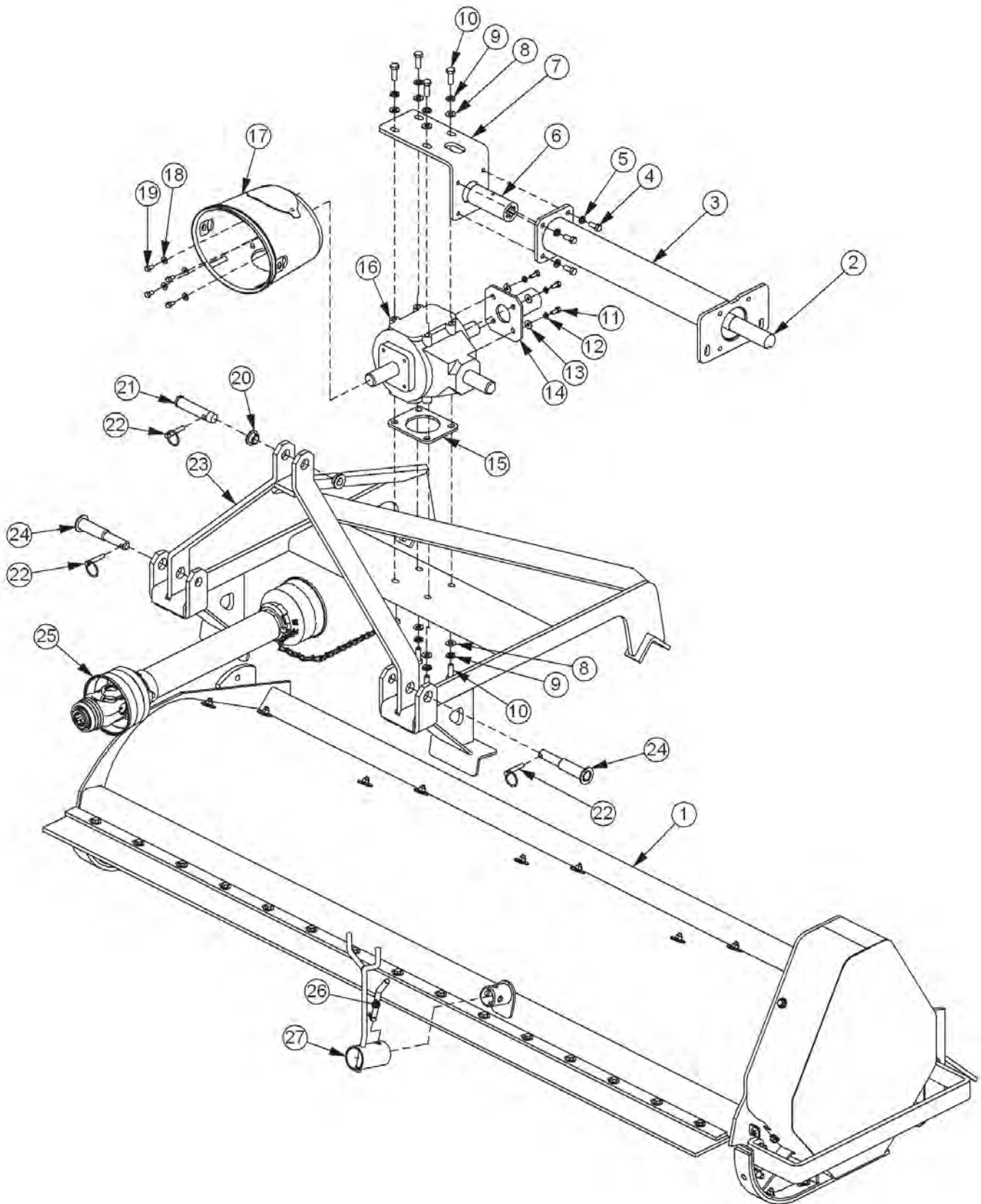

STD DUTY PTO DRIVE ASSEMBLY

ITEM	P/N	QTY	DESCRIPTION
1	06320134	1	BONNET,75,STD,ROSTA
*	06320115	AVAIL.	BONNET,90,STD,ROSTA
2	06420110	1	SHAFT,OUTPUT,TRF75
*	06420092	AVAIL.	SHAFT,OUTPUT,TRF90
*	06420109	AVAIL.	SHAFT,OUTPUT,TRF90(OFFSET)
3	06320133	1	TUBE,SAFETY,75,SD
*	06320117	AVAIL.	TUBE,SAFETY,90,SD
*	06320119	AVAIL.	TUBE,SAFETY,90(OFFSET)
4	21679	4	CAPSCREW,7/16 x 1,NC
5	21989	4	LOCKWASHER,7/16
6	28914	1	COUPLING,6 SPLINE W/ZERK
7	33204	1	PLATE,MNT,GUARD
8	27724	8	LOCKWASHER,12MM
9	22017	4	FLATWASHER,7/16
10	34890	8	CAPSCREW,12MM x 35MM(1.75P)
11	27508	4	CAPSCREW,8MM x 20MM(1.25P)
12	6T2619	4	LOCKWASHER,8MM
13	22015	4	FLATWASHER,5/16
14	28447E	1	GUARD,TRF,OUTPUT SHAFT
15	06400018	1	SPACER,REAR FLAIL (IF NECESSARY)
16	28950	1	GEAR BOX,540 RPM
17	06520181	1	SHIELD,PTO
18	34948	4	FLATWASHER,3/8
19	27507	4	CAPSCREW,8MM x 15MM(1.25P)
20	28235A	2	BUSHING,3PT,CAT II TO CAT I
21	TB1036	1	PIN,SEC BOOM SWIV 1 x 4-11/16
22	TF1143	3	PIN,LYNCH,7/16 x 2
23	06370154	1	FRM,3PT,STD
24	28234B	2	PIN,3PT,TRF,STD
25	06520414	1	PTO,DRV SHFT,TRF
*	06520415	AVAIL.	PTO,DRV SHFT,TRF,W/ CLUTCH
26	06520048	1	PIN,.5 x 2.5,BENT,W/R-CLIP
27	06370022	1	SUPPORT,PTO

HVY DUTY 75" REAR FLAIL STANDARD ROTATION

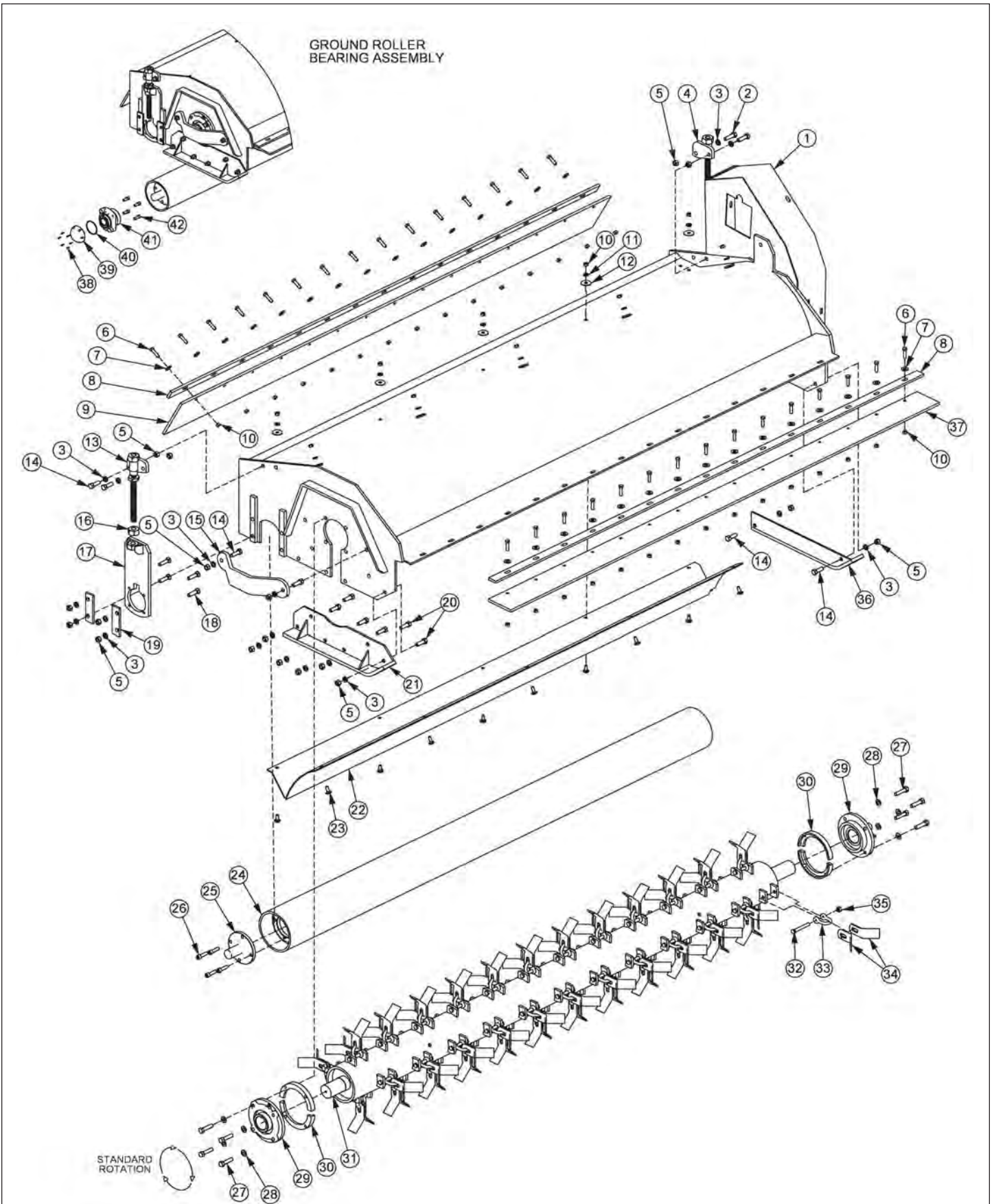

75" REAR FLAIL STANDARD ROTATION

ITEM	P/N	QTY	DESCRIPTION
1	22043J	1	BONNET,75,HD
2	21732	2	CAPSCREW,1/2 x 1-3/4,NC
3	21990	22	LOCKWASHER,1/2
4	TF4335	1	ROD,GROUND ROLLER ADJ,LF
5	21725	22	HEX NUT,1/2,NC
6	21632	26	CAPSCREW,3/8 x 1-1/2,NC
7	22016	26	FLATWASHER,3/8
8	TF1029	2	BAR,FLAP,TSF/TRF 75
9	TF1016	1	FLAP,DEFLECTOR,TSF/TRF 75
10	21625	36	HEX NUT,3/8,NC
11	21988	10	LOCKWASHER,3/8
12	6T2615	10	WASHER,FENDER,3/8
13	TF4334	1	ROD,GROUND ROLLER ADJ,RT
14	21731	6	CAPSCREW, 1/2 x 1-1/2,NC
15	TF1040	1	GUARD,CUTTERSHAFT
16	21399	2	HEX NUT,3/4,ACME THRD
17	TF4333A	2	GROUND ROLLER ADJ BRKT
18	6T2294	8	PLOW BOLT,1/2 x 2,NC
19	TF4336	4	PLATE,GROUND ROLLER LOCK
20	21730	6	CAPSCREW,1/2 x 1-1/4,NC
21	TF4371	1	SKID SHOE,L/PROFILE-OUTER
22	TF1402A	1	BAFFLE,FLAIL,75,HD
23	6T2283	10	CARRIAGE BOLT,3/8 x 1,NC
24	28738	1	GROUND ROLLER,75
25	TF1045B	2	GRND ROLLER STUB SHAFT
26	6T2330	8	CAPSCREW, 7/16 x 1-1/2, SKT HD
27	06530217	8	CAPSCREW,1/2 x 2,NC,L9
28	06533006	8	FLATWASHER,1/2,SAE,L9
29	TF1018	2	BEARING,FLANGE,2-3/16
30	31204	2	STRING GUARD,HD
31	TF1002	1	CUTTERSHAFT ASSY,75,HD
32	30411	40	KNIFE MOUNTING BOLT,FLAIL
33	TF1020	40	KNIFE MTG CLEVIS,FLAIL
34	33714	80	KNIFE,FLAIL,STANDARD
35	21677	40	NYLOCK NUT,7/16,NC
36	TF4365	1	SKID SHOE,L/PROFILE-INNER
37	06520242	1	FLAP,FRONT,75
38	06530001	12	CAPSCREW,SKT HD
39	06520027	2	CAP,BEARING
40	06520029	2	O-RING,2-3/4 x 3/32
41	06520028	2	BEARING,FLANGE,1-3/8
42	6T2331	8	CAPSCREW,7/16 x 1,SKT HD

HVY DUTY 75" REAR FLAIL REVERSE ROTATION

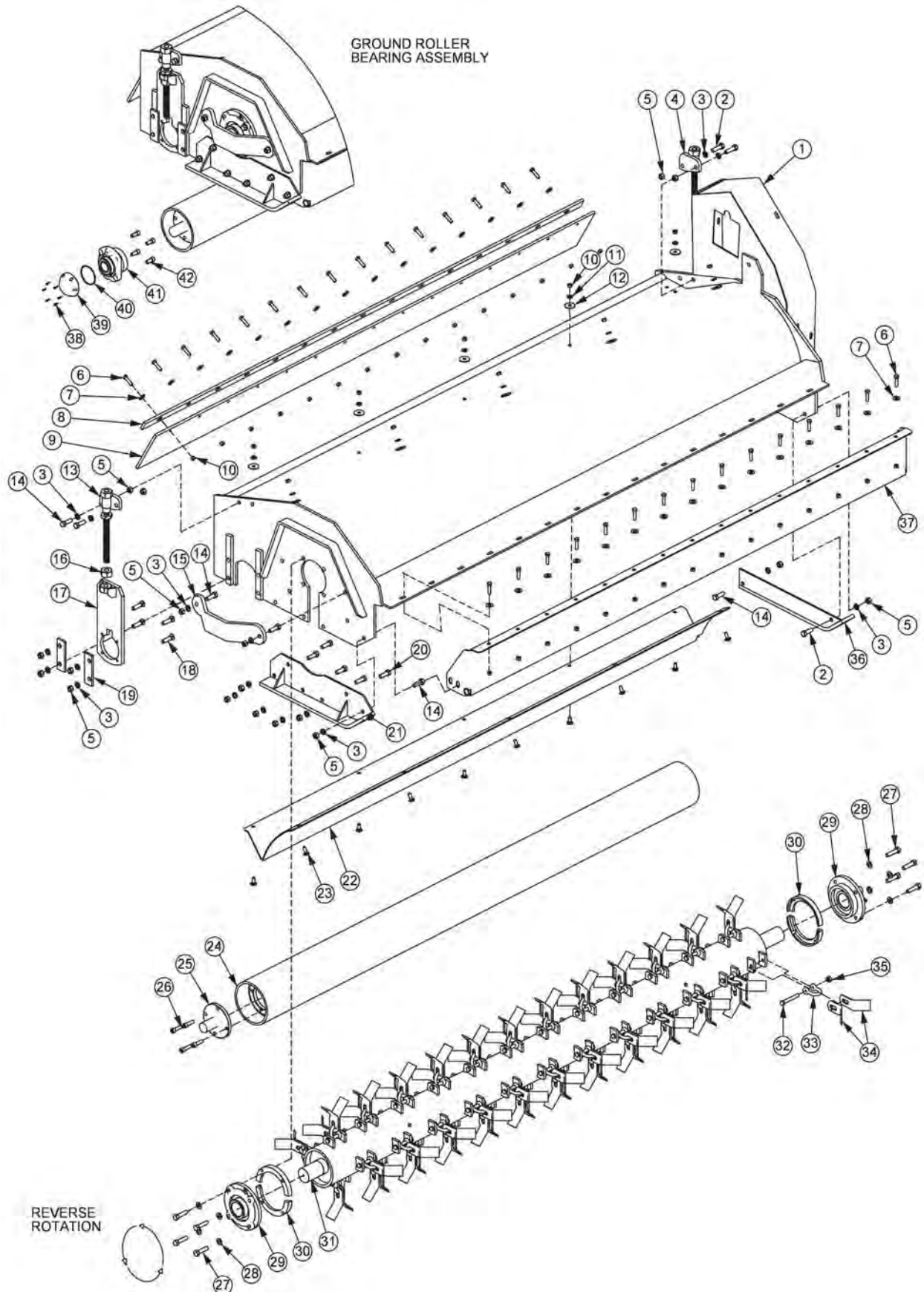

75" REAR FLAIL REVERSE ROTATION

ITEM	P/N	QTY	DESCRIPTION
1	22043J	1	BONNET,75,HD
2	21732	3	CAPSCREW,1/2 x 1-3/4,NC
3	21990	22	LOCKWASHER,1/2
4	TF4335	1	ROD,GROUND ROLLER ADJ,LF
5	21725	22	HEX NUT,1/2,NC
6	21632	26	CAPSCREW,3/8 x 1-1/2,NC
7	22016	26	FLATWASHER,3/8
8	TF1029	1	BAR,FLAP,TSF/TRF 75
9	TF1016	1	FLAP,DEFLECTOR,TSF/TRF 75
10	21625	36	HEX NUT,3/8,NC
11	21988	10	LOCKWASHER,3/8
12	6T2615	10	WASHER,FENDER,3/8
13	TF4334	1	ROD,GROUND ROLLER ADJ,RT
14	21731	6	CAPSCREW, 1/2 x 1-1/2,NC
15	TF1040	1	GUARD,CUTTERSHAFT
16	21399	2	HEX NUT,3/4,ACME THRD
17	TF4333A	2	GROUND ROLLER ADJ BRKT
18	6T2294	8	PLOW BOLT,1/2 x 2,NC
19	TF4336	4	PLATE,GROUND ROLLER LOCK
20	21730	5	CAPSCREW,1/2 x 1-1/4,NC
21	TF4371	1	SKID SHOE,L/PROFILE-OUTER
22	TF1402A	1	BAFFLE,FLAIL,75,HD
23	6T2283	10	CARRIAGE BOLT,3/8 x 1,NC
24	28738	1	GROUND ROLLER,75
25	TF1045B	2	GRND ROLLER STUB SHAFT
26	6T2330	8	CAPSCREW, 7/16 x 1-1/2, SKT HD
27	06530217	8	CAPSCREW,1/2 x 2,NC,L9
28	06533006	8	FLATWASHER,1/2,SAE,L9
29	TF1018	2	BEARING,FLANGE,2-3/16
30	31204	2	STRING GUARD,HD
31	TF1002	1	CUTTERSHAFT ASSY,75,HD
32	30411	40	KNIFE MOUNTING BOLT,FLAIL
33	TF1020	40	KNIFE MTG CLEVIS,FLAIL
34	33714	80	KNIFE,FLAIL,STANDARD
35	21677	40	NYLOCK NUT,7/16,NC
36	TF4365	1	SKID SHOE,L/PROFILE-INNER
37	TF1403	1	FRONT TRASH GUARD
38	06530001	12	CAPSCREW,SKT HD
39	06520027	2	CAP,BEARING
40	06520029	2	O-RING,2-3/4 x 3/32
41	06520028	2	BEARING,FLANGE,1-3/8
42	6T2331	8	CAPSCREW,7/16 x 1,SKT HD

HVY DUTY 75" REAR FLAIL DRIVE ASSEMBLY

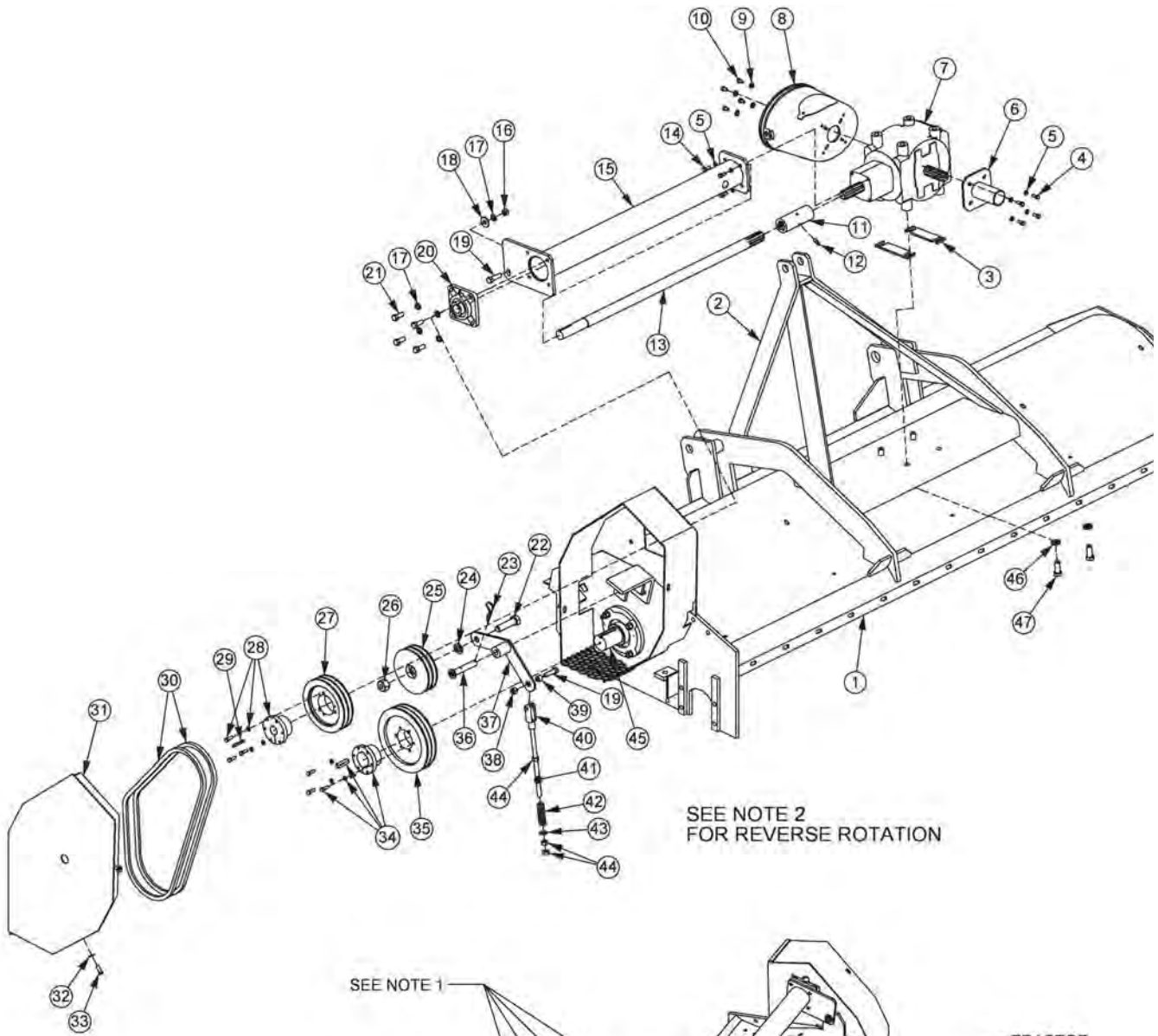

SEE NOTE 2
FOR REVERSE ROTATION

SEE NOTE 1

NOTE:

1. LOCATE AND FIT HITCH PER DRIVE ASSEMBLY PRIOR TO WELDING 3 POINT HITCH TO FLAIL BONNET
2. REVERSE ROTATION ASSEMBLY - PULLY HARDWARE (ITEMS 22, 24, 25 & 26) SWAP ENDS WITH TENSIONER HARDWARE (ITEMS - 19, 38, 39, 40, 41, 42 & 43) ON IDLER ARM ITEM - 37

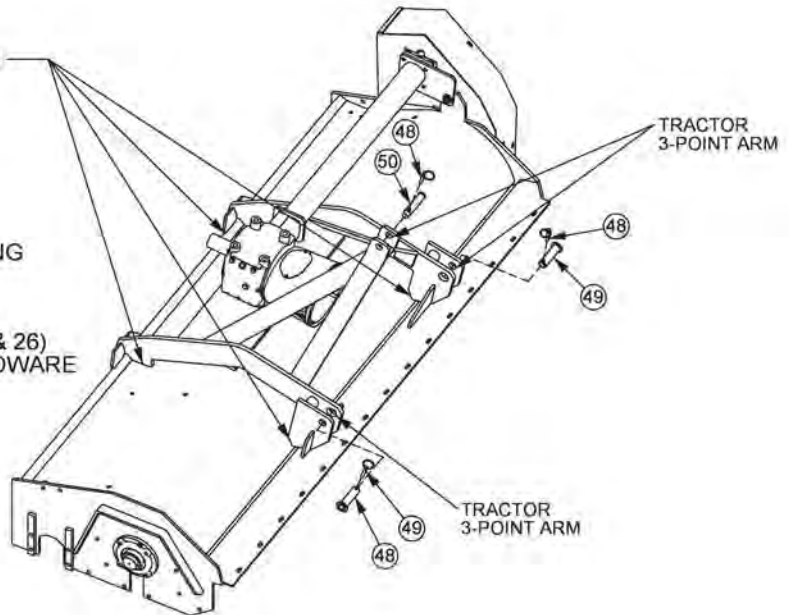

75" REAR FLAIL DRIVE ASSEMBLY

ITEM	P/N	QTY	DESCRIPTION
1	22043J	1	BONNET,75,HD
2	31279A	1	HITCH,3-POINT
3	40454	2	SPACER
4	27508	4	CAPSCREW,8MMx20MM(1.25)
5	6T2619	8	LOCKWASHER,8MM
6	28447E	1	GUARD,OUTPUT SHAFT
7	28505	1	GEARBOX,REAR FLAIL,COMER T22A
8	06520181	1	GUARD,PTO,GRBX
9	34948	4	FLATWASHER,8MM
10	27507	4	CAPSCREW,8MMx15MM(1.25)
11	28914	1	COUPLING,6 SPLINE
12	6T3209	1	GREASE ZERK,1/4 DRIVE
13	28414A	1	OUTPUT EXTENSION SHAFT,75RCM
	28416B	*	OUTPUT EXTENSION SHAFT,75OFF
14	30162	4	CAPSCREW,SKT HD,8MMx20MM(1.25)
15	28422A	1	SHAFT GRD,HD,75RCM
	28424B	*	SHAFT GRD,HD,75OFF
16	21725	1	HEX NUT,1/2,NC
17	21990	5	LOCKWASHER,1/2
18	22018	1	FLATWASHER,1/2,WIDE
19	21732	2	CAPSCREW,1/2x1-3/4,NC
20	28571	1	BEARING,FLANGE,1-1/4
21	21730	4	CAPSCREW,1/2x1-1/4,NC
22	28399	1	CAPSCREW,20MMx80MM(2.5),GR10.9
23	6T3004	1	R-CLIP,HAIRPIN COTTER,3/16
24	24881	1	LOCKWASHER,20MM
25	31295	1	SHEAVE,IDLER ASSY,6.3
26	31740	1	NYLOCK NUT,20MM(2.5)
27	TF3043	1	SHEAVE,7.5
28	30049	2	BUSHING,QD,SK 1-1/4,1/4 KEY
29	28572	1	KEY,1/4SQ x 2
30	TF3023	2	V-BELT(630)
31	31286A	1	SHIELD,BELT
32	21988	4	LOCKWASHER,3/8
33	21630	4	CAPSCREW,3/8x1,NC
34	TF3011	1	BUSHING,QD,SK 2-3/16
35	28570	1	SHEAVE,9.0
36	TF3605	1	PIN,IDLER ARM
37	TF1180	1	IDLER ARM
38	6T2418	1	HEX NUT,1/2,NC,GR8(STOVER)
39	TF3610	1	BUSHING,IDLER
40	PT3611A	1	CLEVIS
41	32482	1	ROD,THREADED,1/2-20,NF,12-1/2
42	TF3620A	1	SPRING,TENSIONER
43	27938	1	BUSHING,MACH,14GA
44	21700	3	HEX NUT,1/2,NF
45	TF1102A	1	CUTTERSHAFT W/ KNIVES
46	6T2625	4	LOCKWASHER,16MM
47	22421	4	CAPSCREW,16MMx40MM(2.0),GR10.9
48	TF1143	3	LYNCH PIN
49	TF1120	2	PIN,CAPPED
50	TB1036	1	PIN

90" REAR FLAIL STANDARD ROTATION

ITEM	P/N	QTY	DESCRIPTION
1	22044J	1	BONNET,90,HD
2	21732	2	CAPSCREW,1/2 x 1-3/4,NC
3	21990	22	LOCKWASHER,1/2
4	TF4335	1	ROD,GROUND ROLLER ADJ,LF
5	21725	22	HEX NUT,1/2,NC
6	21632	30	CAPSCREW,3/8 x 1-1/2,NC
7	22016	30	FLATWASHER,3/8
8	TF1135	2	BAR,FLAP,TSF/TRF 90
9	TF1116	1	FLAP,DEFLECTOR,TSF/TRF 90
10	21625	40	HEX NUT,3/8,NC
11	21988	10	LOCKWASHER,3/8
12	6T2615	10	WASHER,FENDER,3/8
13	TF4334	1	ROD,GROUND ROLLER ADJ,RT
14	21731	6	CAPSCREW, 1/2 x 1-1/2,NC
15	TF1040	1	GUARD,CUTTERSHAFT
16	21399	2	HEX NUT,3/4,ACME THRD
17	TF4333A	2	GROUND ROLLER ADJ BRKT
18	6T2294	8	PLOW BOLT,1/2 x 2,NC
19	TF4336	4	PLATE,GROUND ROLLER LOCK
20	21730	6	CAPSCREW,1/2 x 1-1/4,NC
21	TF4371	1	SKID SHOE,L/PROFILE-OUTER
22	TF1502A	1	BAFFLE,FLAIL,90,HD
23	6T2283	10	CARRIAGE BOLT,3/8 x 1,NC
24	27972A	1	GROUND ROLLER,90
25	TF1045B	2	GRND ROLLER STUB SHAFT
26	6T2330	8	CAPSCREW, 7/16 x 1-1/2, SKT HD
27	06530217	8	CAPSCREW,1/2 x 2,NC,L9
28	06533006	8	FLATWASHER,1/2,SAE,L9
29	TF1018	2	BEARING,FLANGE,2-3/16
30	31204	2	STRING GUARD,HD
31	TF1102	1	CUTTERSHAFT ASSY,90,HD
32	30411	48	KNIFE MOUNTING BOLT,FLAIL
33	TF1020	48	KNIFE MTG CLEVIS,FLAIL
34	33714	96	KNIFE,FLAIL,STANDARD
35	21677	48	NYLOCK NUT,7/16,NC
36	TF4365	1	SKID SHOE,L/PROFILE-INNER
37	06520243	1	FLAP,FRONT,90
38	06530001	12	CAPSCREW,SKT HD
39	06520027	2	CAP,BEARING
40	06520029	2	O-RING,2-3/4 x 3/32
41	06520028	2	BEARING,FLANGE,1-3/8
42	6T2331	8	CAPSCREW,7/16 x 1,SKT HD

HVY DUTY 90" REAR FLAIL REVERSE ROTATION

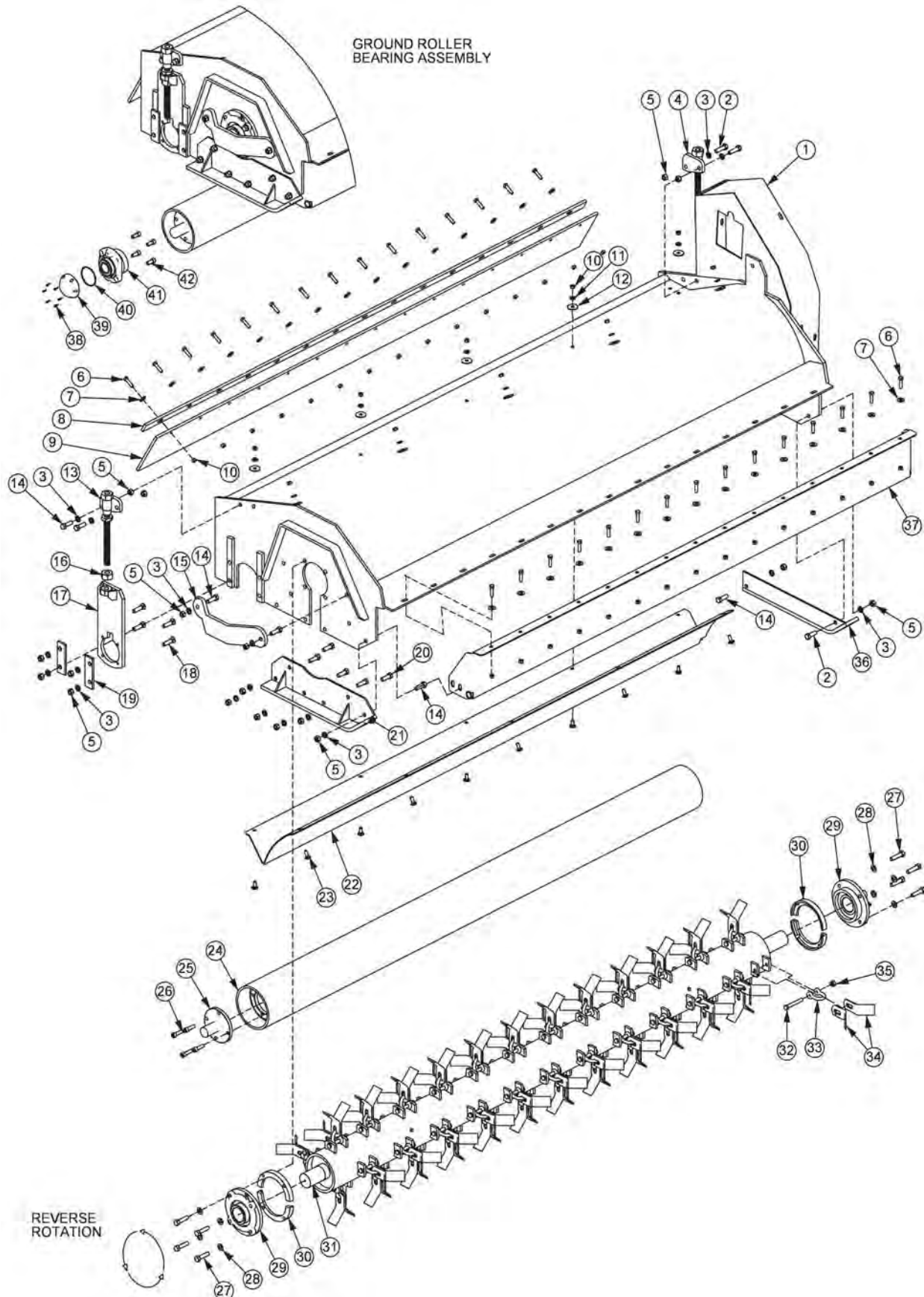

90" REAR FLAIL REVERSE ROTATION

ITEM	P/N	QTY	DESCRIPTION
1	22044J	1	BONNET,90,HD
2	21732	3	CAPSCREW,1/2 x 1-3/4,NC
3	21990	22	LOCKWASHER,1/2
4	TF4335	1	ROD,GROUND ROLLER ADJ,LF
5	21725	22	HEX NUT,1/2,NC
6	21632	30	CAPSCREW,3/8 x 1-1/2,NC
7	22016	30	FLATWASHER,3/8
8	TF1135	1	BAR,FLAP,TSF/TRF 90
9	TF1116	1	FLAP,DEFLECTOR,TSF/TRF 90
10	21625	40	HEX NUT,3/8,NC
11	21988	10	LOCKWASHER,3/8
12	6T2615	10	WASHER,FENDER,3/8
13	TF4334	1	ROD,GROUND ROLLER ADJ,RT
14	21731	6	CAPSCREW, 1/2 x 1-1/2,NC
15	TF1040	1	GUARD,CUTTERSHAFT
16	21399	2	HEX NUT,3/4,ACME THRD
17	TF4333A	2	GROUND ROLLER ADJ BRKT
18	6T2294	8	PLOW BOLT,1/2 x 2,NC
19	TF4336	4	PLATE,GROUND ROLLER LOCK
20	21730	5	CAPSCREW,1/2 x 1-1/4,NC
21	TF4371	1	SKID SHOE,L/PROFILE-OUTER
22	TF1502A	1	BAFFLE,FLAIL,90,HD
23	6T2283	10	CARRIAGE BOLT,3/8 x 1,NC
24	27972A	1	GROUND ROLLER,90
25	TF1045B	2	GRND ROLLER STUB SHAFT
26	6T2330	8	CAPSCREW, 7/16 x 1-1/2, SKT HD
27	06530217	8	CAPSCREW,1/2 x 2,NC,L9
28	06533006	8	FLATWASHER,1/2,SAE,L9
29	TF1018	2	BEARING,FLANGE,2-3/16
30	31204	2	STRING GUARD,HD
31	TF1102	1	CUTTERSHAFT ASSY,90,HD
32	30411	48	KNIFE MOUNTING BOLT,FLAIL
33	TF1020	48	KNIFE MTG CLEVIS,FLAIL
34	33714	96	KNIFE,FLAIL,STANDARD
35	21677	48	NYLOCK NUT,7/16,NC
36	TF4365	1	SKID SHOE,L/PROFILE-INNER
37	TF1503	1	FRONT TRASH GUARD
38	06530001	12	CAPSCREW,SKT HD
39	06520027	2	CAP,BEARING
40	06520029	2	O-RING,2-3/4 x 3/32
41	06520028	2	BEARING,FLANGE,1-3/8
42	6T2331	8	CAPSCREW,7/16 x 1,SKT HD

HVY DUTY 90" REAR FLAIL DRIVE ASSEMBLY

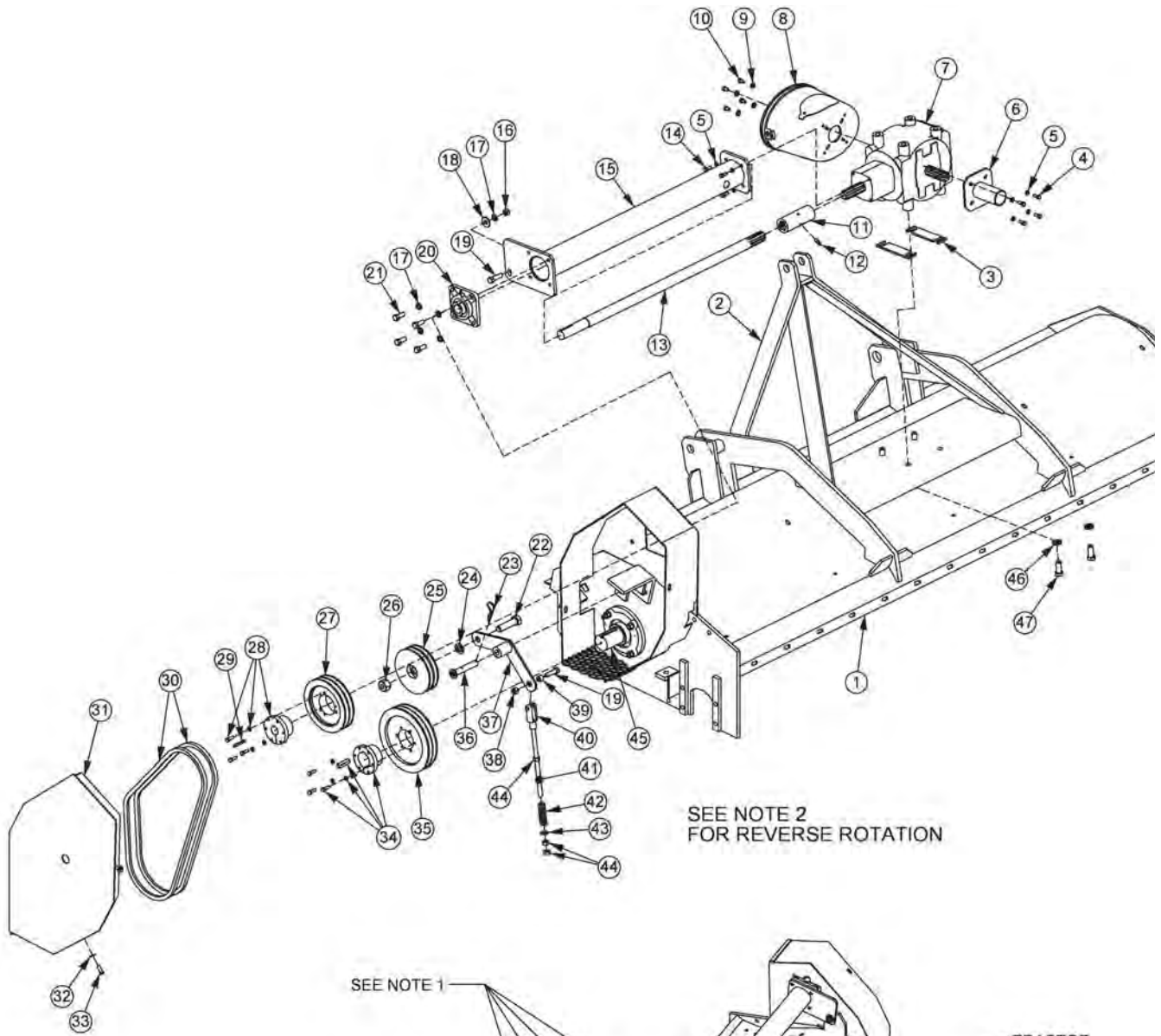

SEE NOTE 2
FOR REVERSE ROTATION

SEE NOTE 1

NOTE:

1. LOCATE AND FIT HITCH PER DRIVE ASSEMBLY PRIOR TO WELDING 3 POINT HITCH TO FLAIL BONNET
2. REVERSE ROTATION ASSEMBLY - PULLY HARDWARE (ITEMS 22,24,25 & 26) SWAP ENDS WITH TENSIONER HARDWARE (ITEMS - 19,38,39,40,41,42 & 43) ON IDLER ARM ITEM - 37

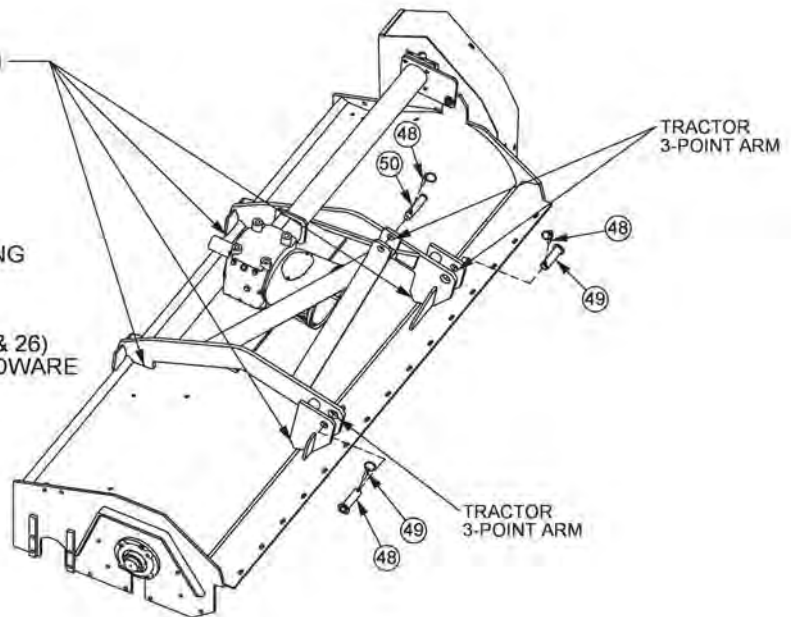

90" REAR FLAIL DRIVE ASSEMBLY

ITEM	P/N	QTY	DESCRIPTION
1	22044J	1	BONNET,90,HD
2	31279A	1	HITCH,3-POINT
3	40454	2	SPACER
4	27508	4	CAPSCREW,8MMx20MM(1.25)
5	6T2619	8	LOCKWASHER,8MM
6	28447E	1	GUARD,OUTPUT SHAFT
7	28505	1	GEARBOX,REAR FLAIL,COMER T22A
8	06520181	1	GUARD,PTO,GRBX
9	34948	4	FLATWASHER,8MM
10	27507	4	CAPSCREW,8MMx15MM(1.25)
11	28914	1	COUPLING,6 SPLINE
12	6T3209	1	GREASE ZERK,1/4 DRIVE
13	28415A	1	OUTPUT EXTENSION SHAFT,90RCM
	28416B	*	OUTPUT EXTENSION SHAFT,90R6F
	28420B	*	OUTPUT EXTENSION SHAFT,90OFF
14	30162	4	CAPSCREW,SKT HD,8MMx20MM(1.25)
15	28423A	1	SHAFT GRD,HD,90RCM
	28424B	*	SHAFT GRD,HD,90R6F
	28428B	*	SHAFT GRD,HD,90OFF
16	21725	1	HEX NUT,1/2,NC
17	21990	5	LOCKWASHER,1/2
18	22018	1	FLATWASHER,1/2,WIDE
19	21732	2	CAPSCREW,1/2x1-3/4,NC
20	28571	1	BEARING,FLANGE,1-1/4
21	21730	4	CAPSCREW,1/2x1-1/4,NC
22	28399	1	CAPSCREW,20MMx80MM(2.5),GR10.9
23	6T3004	1	R-CLIP,HAIRPIN COTTER,3/16
24	24881	1	LOCKWASHER,20MM
25	31295	1	SHEAVE,IDLER ASSY,6.3
26	31740	1	NYLOCK NUT,20MM(2.5)
27	TF3043	1	SHEAVE,7.5
28	30049	2	BUSHING,QD,SK 1-1/4,1/4 KEY
29	28572	1	KEY,1/4SQ x 2
30	TF3023	2	V-BELT(630)
31	31286A	1	SHIELD,BELT
32	21988	4	LOCKWASHER,3/8
33	21630	4	CAPSCREW,3/8x1,NC
34	TF3011	1	BUSHING,QD,SK 2-3/16
35	28570	1	SHEAVE,9.0
36	TF3605	1	PIN,IDLER ARM
37	TF1180	1	IDLER ARM
38	6T2418	1	HEX NUT,1/2,NC,GR8(STOVER)
39	TF3610	1	BUSHING,IDLER
40	PT3611A	1	CLEVIS
41	32482	1	ROD,THREADED,1/2-20,NF,12-1/2
42	TF3620A	1	SPRING,TENSIONER
43	27938	1	BUSHING,MACH,14GA
44	21700	3	HEX NUT,1/2,NF
45	TF1102A	1	CUTTERSHAFT W/ KNIVES
46	6T2625	4	LOCKWASHER,16MM
47	22421	4	CAPSCREW,16MMx40MM(2.0),GR10.9
48	TF1143	3	LYNCH PIN
49	TF1120	2	PIN,CAPPED
50	TB1036	1	PIN

HVY DUTY 96" REAR FLAIL STANDARD ROTATION

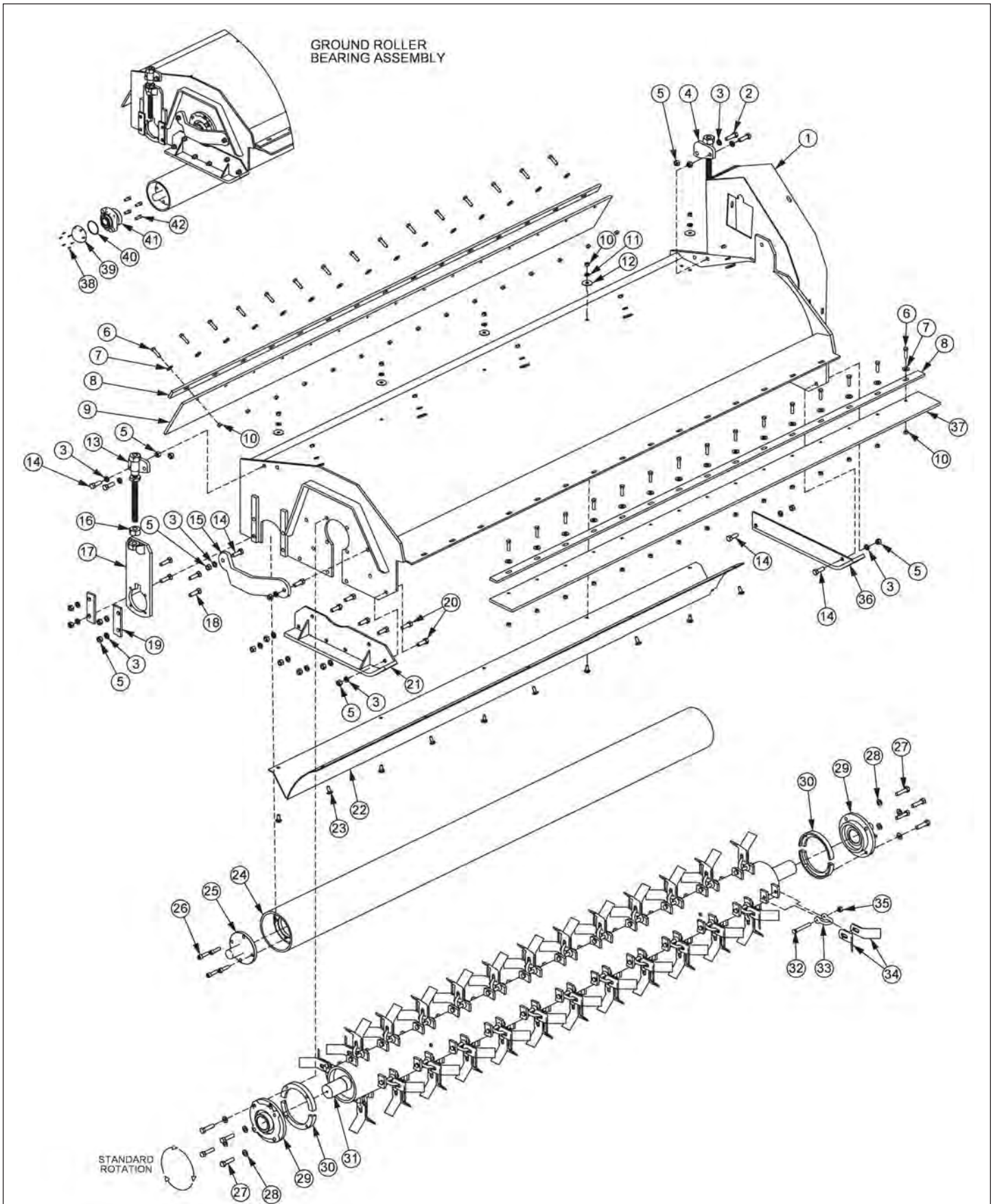

96" REAR FLAIL STANDARD ROTATION

ITEM	P/N	QTY	DESCRIPTION
1	22045J	1	BONNET,96,HD
2	21732	2	CAPSCREW,1/2 x 1-3/4,NC
3	21990	22	LOCKWASHER,1/2
4	TF4335	1	ROD,GROUND ROLLER ADJ,LF
5	21725	22	HEX NUT,1/2,NC
6	21632	34	CAPSCREW,3/8 x 1-1/2,NC
7	22016	34	FLATWASHER,3/8
8	TF1606	2	BAR,FLAP,TSF/TRF 96
9	TF1605	1	FLAP,DEFLECTOR,TSF/TRF 96
10	21625	44	HEX NUT,3/8,NC
11	21988	10	LOCKWASHER,3/8
12	6T2615	10	WASHER,FENDER,3/8
13	TF4334	1	ROD,GROUND ROLLER ADJ,RT
14	21731	6	CAPSCREW, 1/2 x 1-1/2,NC
15	TF1040	1	GUARD,CUTTERSHAFT
16	21399	2	HEX NUT,3/4,ACME THRD
17	TF4333A	2	GROUND ROLLER ADJ BRKT
18	6T2294	8	PLOW BOLT,1/2 x 2,NC
19	TF4336	4	PLATE,GROUND ROLLER LOCK
20	21730	6	CAPSCREW,1/2 x 1-1/4,NC
21	TF4371	1	SKID SHOE,L/PROFILE-OUTER
22	TF1607	1	BAFFLE,FLAIL,96,HD
23	6T2283	10	CARRIAGE BOLT,3/8 x 1,NC
24	TF1603	1	GROUND ROLLER,96
25	TF1045B	2	GRND ROLLER STUB SHAFT
26	6T2330	8	CAPSCREW, 7/16 x 1-1/2, SKT HD
27	06530217	8	CAPSCREW,1/2 x 2,NC,L9
28	06533006	8	FLATWASHER,1/2,SAE,L9
29	TF1018	2	BEARING,FLANGE,2-3/16
30	31204	2	STRING GUARD,HD
31	TF1602B	1	CUTTERSHAFT ASSY,96,HD
32	30411	52	KNIFE MOUNTING BOLT,FLAIL
33	TF1020	52	KNIFE MTG CLEVIS,FLAIL
34	33714	104	KNIFE,FLAIL,STANDARD
35	21677	52	NYLOCK NUT,7/16,NC
36	TF4365	1	SKID SHOE,L/PROFILE-INNER
37	06520244	1	FLAP,FRONT,96
38	06530001	12	CAPSCREW,SKT HD
39	06520027	2	CAP,BEARING
40	06520029	2	O-RING,2-3/4 x 3/32
41	06520028	2	BEARING,FLANGE,1-3/8
42	6T2331	8	CAPSCREW,7/16 x 1,SKT HD

HVY DUTY 96" REAR FLAIL REVERSE ROTATION

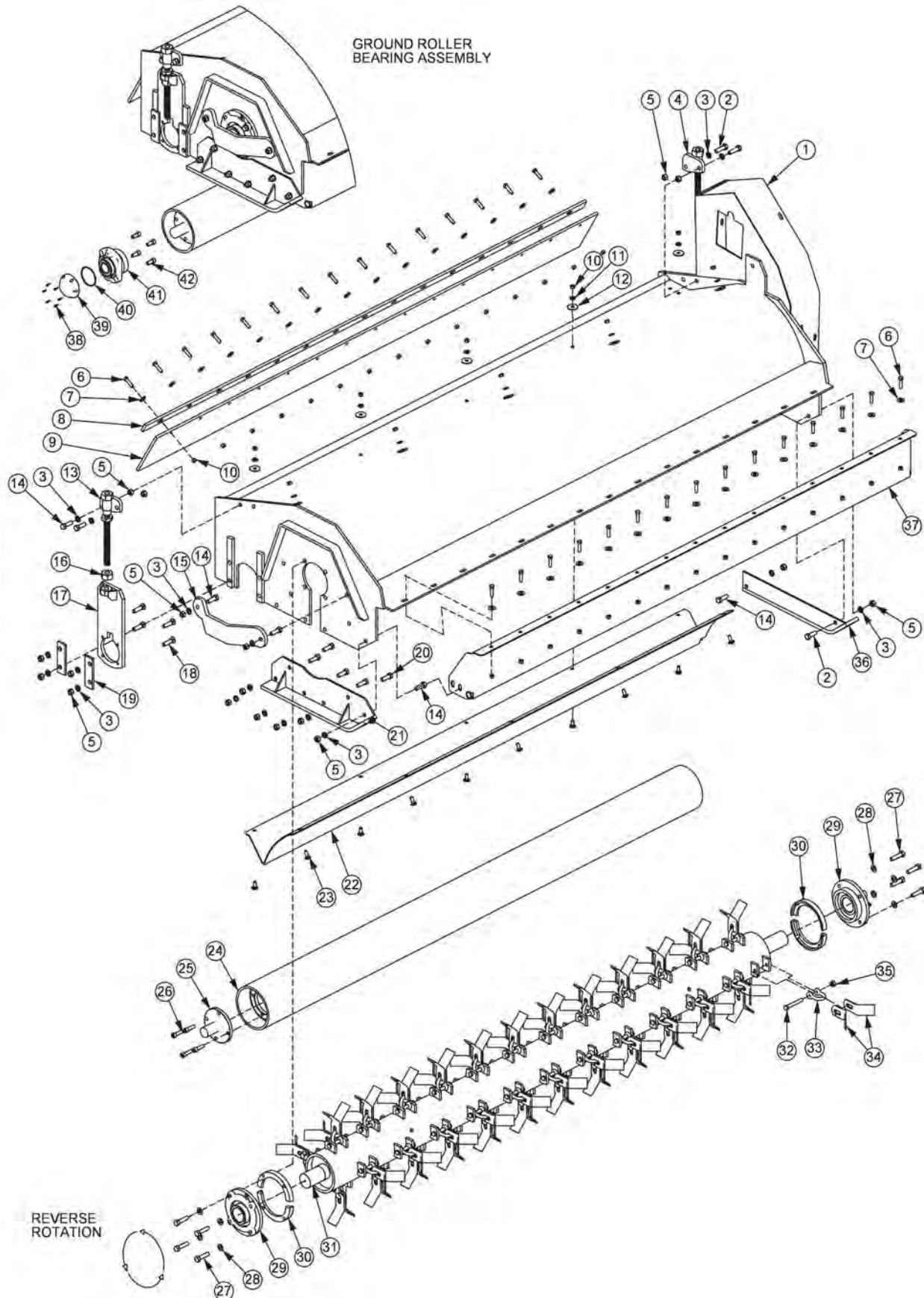

96" REAR FLAIL REVERSE ROTATION

ITEM	P/N	QTY	DESCRIPTION
1	22045J	1	BONNET,96,HD
2	21732	3	CAPSCREW,1/2 x 1-3/4,NC
3	21990	22	LOCKWASHER,1/2
4	TF4335	1	ROD,GROUND ROLLER ADJ,LF
5	21725	22	HEX NUT,1/2,NC
6	21632	34	CAPSCREW,3/8 x 1-1/2,NC
7	22016	34	FLATWASHER,3/8
8	TF1606	1	BAR,FLAP,TSF/TRF 96
9	TF1605	1	FLAP,DEFLECTOR,TSF/TRF 96
10	21625	44	HEX NUT,3/8,NC
11	21988	10	LOCKWASHER,3/8
12	6T2615	10	WASHER,FENDER,3/8
13	TF4334	1	ROD,GROUND ROLLER ADJ,RT
14	21731	6	CAPSCREW, 1/2 x 1-1/2,NC
15	TF1040	1	GUARD,CUTTERSHAFT
16	21399	2	HEX NUT,3/4,ACME THRD
17	TF4333A	2	GROUND ROLLER ADJ BRKT
18	6T2294	8	PLOW BOLT,1/2 x 2,NC
19	TF4336	4	PLATE,GROUND ROLLER LOCK
20	21730	5	CAPSCREW,1/2 x 1-1/4,NC
21	TF4371	1	SKID SHOE,L/PROFILE-OUTER
22	TF1607	1	BAFFLE,FLAIL,96,HD
23	6T2283	10	CARRIAGE BOLT,3/8 x 1,NC
24	TF1603	1	GROUND ROLLER,96
25	TF1045B	2	GRND ROLLER STUB SHAFT
26	6T2330	8	CAPSCREW, 7/16 x 1-1/2, SKT HD
27	06530217	8	CAPSCREW,1/2 x 2,NC,L9
28	06533006	8	FLATWASHER,1/2,SAE,L9
29	TF1018	2	BEARING,FLANGE,2-3/16
30	31204	2	STRING GUARD,HD
31	TF1602B	1	CUTTERSHAFT ASSY,96,HD
32	30411	52	KNIFE MOUNTING BOLT,FLAIL
33	TF1020	52	KNIFE MTG CLEVIS,FLAIL
34	33714	104	KNIFE,FLAIL,STANDARD
35	21677	52	NYLOCK NUT,7/16,NC
36	TF4365	1	SKID SHOE,L/PROFILE-INNER
37	TF1608	1	FLAP TRASH GUARD
38	06530001	12	CAPSCREW,SKT HD
39	06520027	2	CAP,BEARING
40	06520029	2	O-RING,2-3/4 x 3/32
41	06520028	2	BEARING,FLANGE,1-3/8
42	6T2331	8	CAPSCREW,7/16 x 1,SKT HD

HVY DUTY 96" REAR FLAIL DRIVE ASSEMBLY

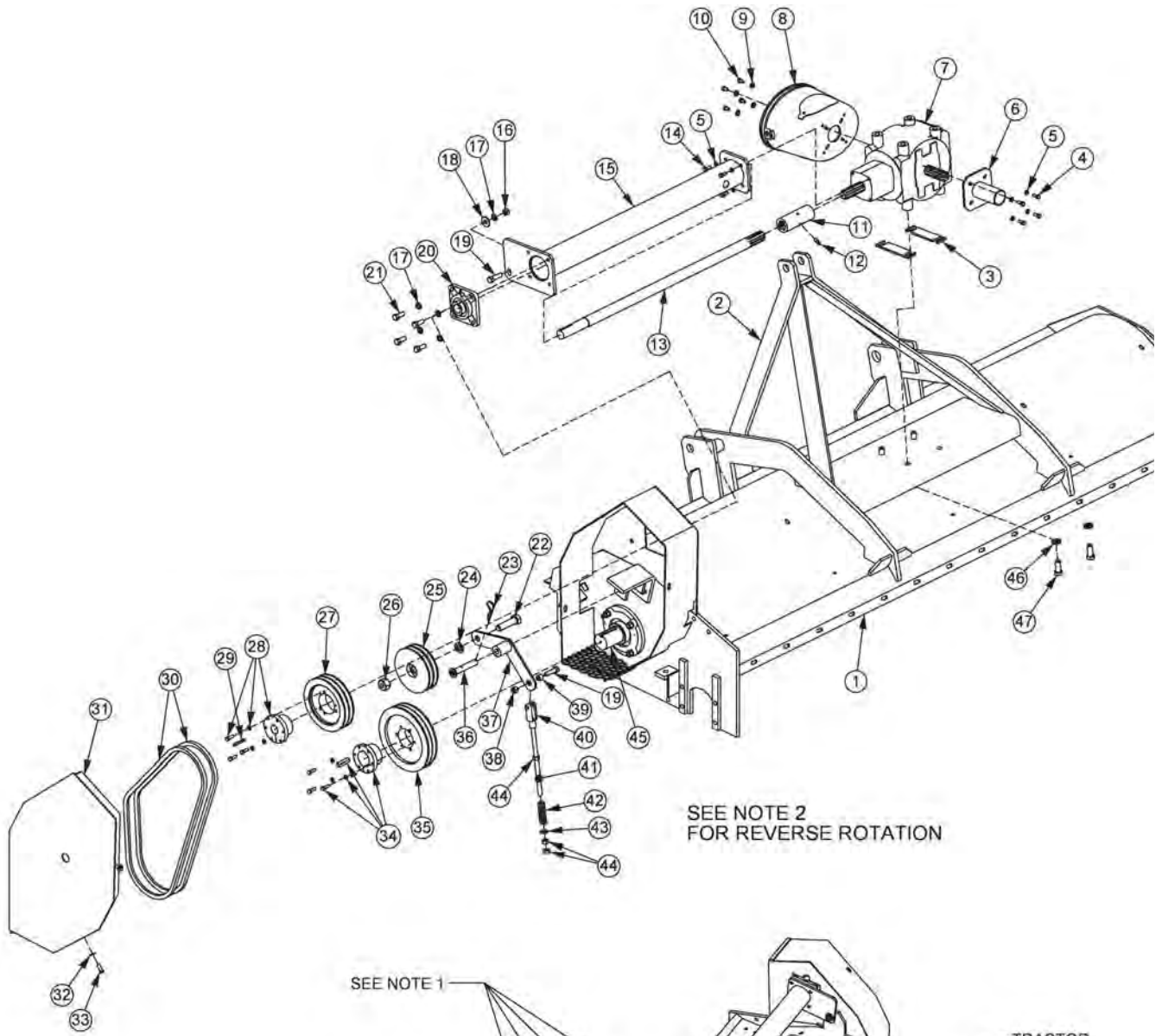

NOTE:

1. LOCATE AND FIT HITCH PER DRIVE ASSEMBLY PRIOR TO WELDING 3 POINT HITCH TO FLAIL BONNET
2. REVERSE ROTATION ASSEMBLY - PULLY HARDWARE (ITEMS 22, 24, 25 & 26) SWAP ENDS WITH TENSIONER HARDWARE (ITEMS - 19, 38, 39, 40, 41, 42 & 43) ON IDLER ARM ITEM - 37

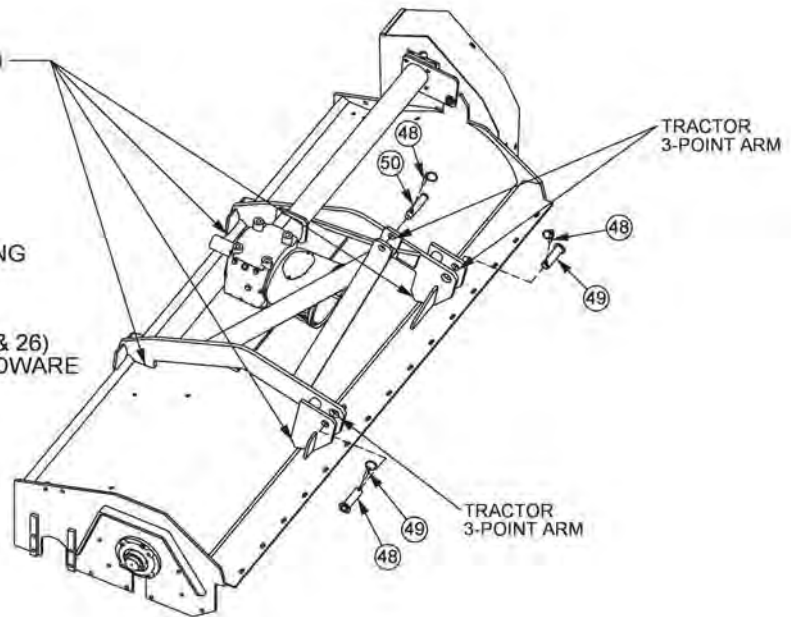

96" REAR FLAIL DRIVE ASSEMBLY

ITEM	P/N	QTY	DESCRIPTION
1	22045J	1	BONNET,96,HD
2	31279A	1	HITCH,3-POINT
3	40454	2	SPACER
4	27508	4	CAPSCREW,8MMx20MM(1.25)
5	6T2619	8	LOCKWASHER,8MM
6	28447E	1	GUARD,OUTPUT SHAFT
7	28505	1	GEARBOX,REAR FLAIL,COMER T22A
8	06520181	1	GUARD,PTO,GRBX
9	34948	4	FLATWASHER,8MM
10	27507	4	CAPSCREW,8MMx15MM(1.25)
11	28914	1	COUPLING,6 SPLINE
12	6T3209	1	GREASE ZERK,1/4 DRIVE
13	28418A	1	OUTPUT EXTENSION SHAFT,96RCM
	28420B	*	OUTPUT EXTENSION SHAFT,96R6F
	28416B	*	OUTPUT EXTENSION SHAFT,96RXF
	28419B	*	OUTPUT EXTENSION SHAFT,96OFF
14	30162	4	CAPSCREW,SKT HD,8MMx20MM(1.25)
15	28426A	1	SHAFT GRD,HD,96RCM
	28428B	*	SHAFT GRD,HD,96R6F
	28424B	*	SHAFT GRD,HD,96RXF
	28427B	*	SHAFT GRD,HD,96OFF
16	21725	1	HEX NUT,1/2,NC
17	21990	5	LOCKWASHER,1/2
18	22018	1	FLATWASHER,1/2,WIDE
19	21732	2	CAPSCREW,1/2x1-3/4,NC
20	28571	1	BEARING,FLANGE,1-1/4
21	21730	4	CAPSCREW,1/2x1-1/4,NC
22	28399	1	CAPSCREW,20MMx80MM(2.5),GR10.9
23	6T3004	1	R-CLIP,HAIRPIN COTTER,3/16
24	24881	1	LOCKWASHER,20MM
25	31295	1	SHEAVE,IDLER ASSY,6.3
26	31740	1	NYLOCK NUT,20MM(2.5)
27	TF3043	1	SHEAVE,7.5
28	30049	2	BUSHING,QD,SK 1-1/4,1/4 KEY
29	28572	1	KEY,1/4SQ x 2
30	TF3023	2	V-BELT(630)
31	31286A	1	SHIELD,BELT
32	21988	4	LOCKWASHER,3/8
33	21630	4	CAPSCREW,3/8x1,NC
34	TF3011	1	BUSHING,QD,SK 2-3/16
35	28570	1	SHEAVE,9.0
36	TF3605	1	PIN,IDLER ARM
37	TF1180	1	IDLER ARM
38	6T2418	1	HEX NUT,1/2,NC,GR8(STOVER)
39	TF3610	1	BUSHING,IDLER
40	PT3611A	1	CLEVIS
41	32482	1	ROD,THREADED,1/2-20,NF,12-1/2
42	TF3620A	1	SPRING,TENSIONER
43	27938	1	BUSHING,MACH,14GA
44	21700	3	HEX NUT,1/2,NF
45	TF1102A	1	CUTTERSHAFT W/ KNIVES
46	6T2625	4	LOCKWASHER,16MM
47	22421	4	CAPSCREW,16MMx40MM(2.0),GR10.9
48	TF1143	3	LYNCH PIN
49	TF1120	2	PIN,CAPPED
50	TB1036	1	PIN

HVY DUTY 102" REAR FLAIL STANDARD ROTATION

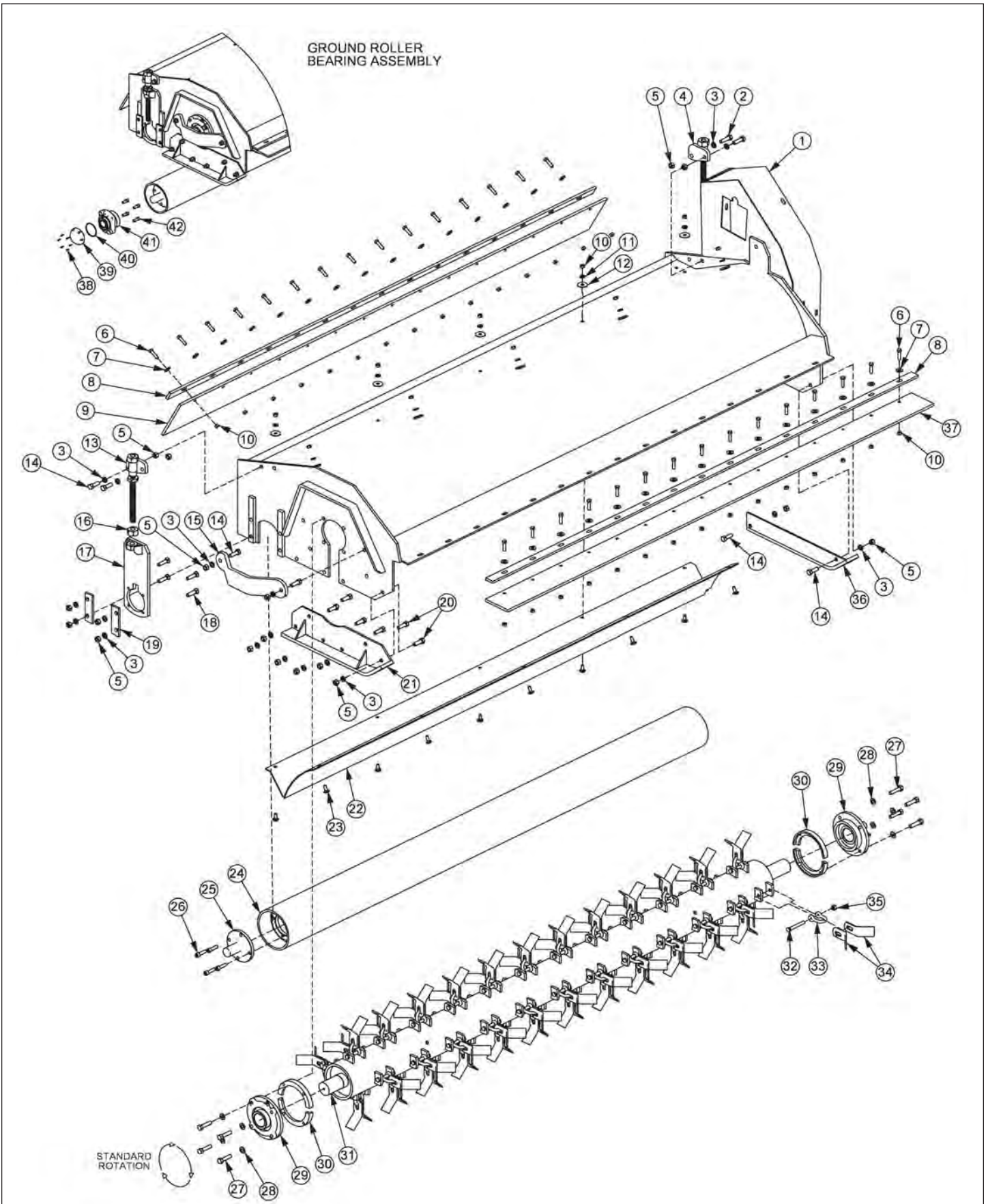

102" REAR FLAIL STANDARD ROTATION

ITEM	P/N	QTY	DESCRIPTION
1	22046J	1	BONNET,102,HD
2	21732	2	CAPSCREW,1/2 x 1-3/4,NC
3	21990	22	LOCKWASHER,1/2
4	TF4335	1	ROD,GROUND ROLLER ADJ,LF
5	21725	22	HEX NUT,1/2,NC
6	21632	36	CAPSCREW,3/8 x 1-1/2,NC
7	22016	36	FLATWASHER,3/8
8	TF1703	2	BAR,FLAP,TSF/TRF 102
9	TF1704A	1	FLAP,DEFLECTOR,TSF/TRF 102
10	21625	46	HEX NUT,3/8,NC
11	21988	10	LOCKWASHER,3/8
12	6T2615	10	WASHER,FENDER,3/8
13	TF4334	1	ROD,GROUND ROLLER ADJ,RT
14	21731	6	CAPSCREW, 1/2 x 1-1/2,NC
15	TF1040	1	GUARD,CUTTERSHAFT
16	21399	2	HEX NUT,3/4,ACME THRD
17	TF4333A	2	GROUND ROLLER ADJ BRKT
18	6T2294	8	PLOW BOLT,1/2 x 2,NC
19	TF4336	4	PLATE,GROUND ROLLER LOCK
20	21730	6	CAPSCREW,1/2 x 1-1/4,NC
21	TF4371	1	SKID SHOE,L/PROFILE-OUTER
22	TF1702	1	BAFFLE,FLAIL,102,HD
23	6T2283	10	CARRIAGE BOLT,3/8 x 1,NC
24	28999	1	GROUND ROLLER,102
25	TF1045B	2	GRND ROLLER STUB SHAFT
26	6T2330	8	CAPSCREW, 7/16 x 1-1/2, SKT HD
27	06530217	8	CAPSCREW,1/2 x 2,NC,L9
28	06533006	8	FLATWASHER,1/2,SAE,L9
29	TF1018	2	BEARING,FLANGE,2-3/16
30	31204	2	STRING GUARD,HD
31	TF1707C	1	CUTTERSHAFT ASSY,102,HD
32	30411	56	KNIFE MOUNTING BOLT,FLAIL
33	TF1020	56	KNIFE MTG CLEVIS,FLAIL
34	33714	112	KNIFE,FLAIL,STANDARD
35	21677	56	NYLOCK NUT,7/16,NC
36	TF4365	1	SKID SHOE,L/PROFILE-INNER
37	06520245	1	FLAP,FRONT,102
38	06530001	12	CAPSCREW,SKT HD
39	06520027	2	CAP,BEARING
40	06520029	2	O-RING,2-3/4 x 3/32
41	06520028	2	BEARING,FLANGE,1-3/8
42	6T2331	8	CAPSCREW,7/16 x 1,SKT HD

HVY DUTY 102" REAR FLAIL REVERSE ROTATION

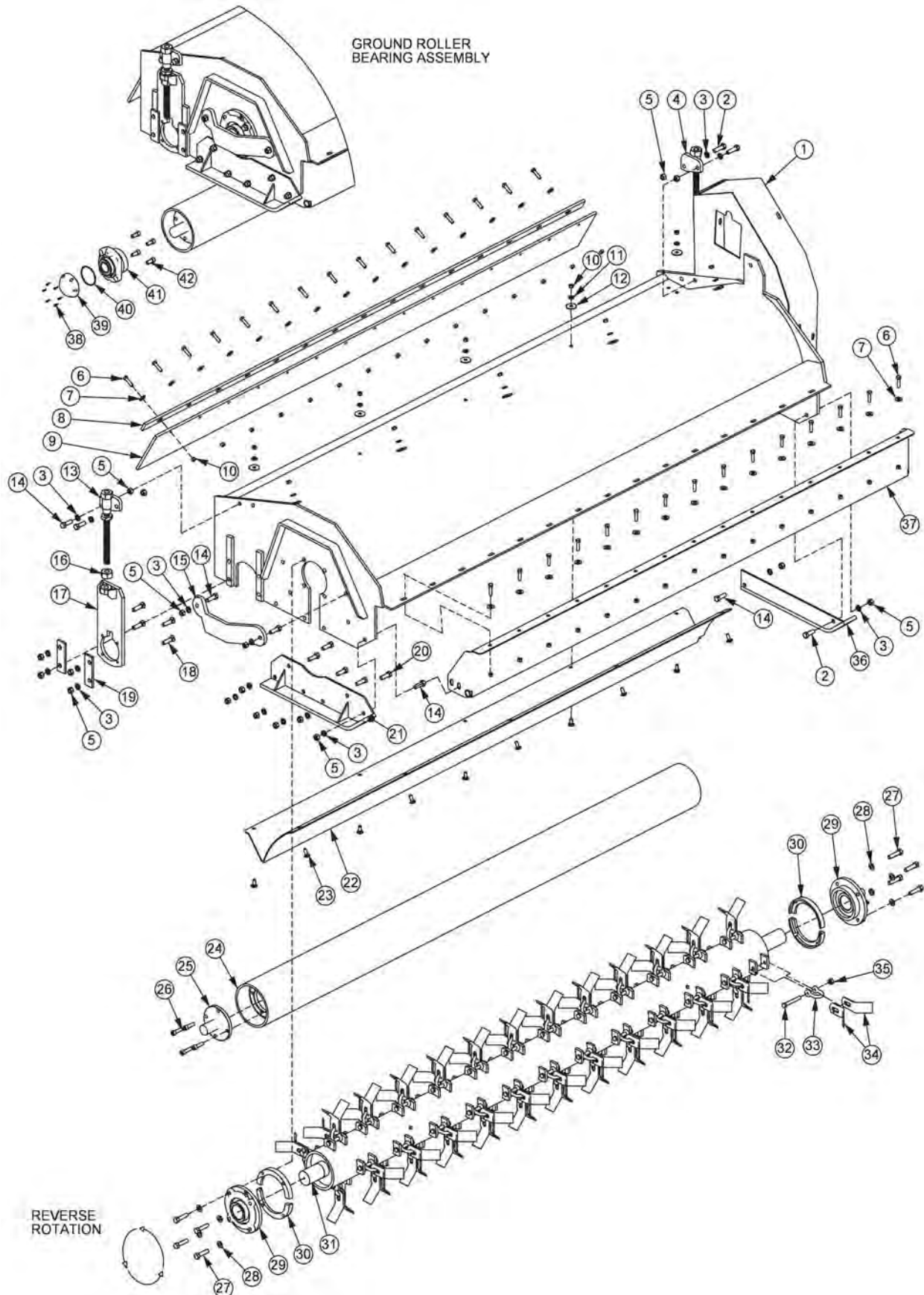

102" REAR FLAIL REVERSE ROTATION

ITEM	P/N	QTY	DESCRIPTION
1	22046J	1	BONNET,102,HD
2	21732	3	CAPSCREW,1/2 x 1-3/4,NC
3	21990	22	LOCKWASHER,1/2
4	TF4335	1	ROD,GROUND ROLLER ADJ,LF
5	21725	22	HEX NUT,1/2,NC
6	21632	36	CAPSCREW,3/8 x 1-1/2,NC
7	22016	36	FLATWASHER,3/8
8	TF1703	1	BAR,FLAP,TSF/TRF 102
9	TF1704A	1	FLAP,DEFLECTOR,TSF/TRF 102
10	21625	46	HEX NUT,3/8,NC
11	21988	10	LOCKWASHER,3/8
12	6T2615	10	WASHER,FENDER,3/8
13	TF4334	1	ROD,GROUND ROLLER ADJ,RT
14	21731	6	CAPSCREW, 1/2 x 1-1/2,NC
15	TF1040	1	GUARD,CUTTERSHAFT
16	21399	2	HEX NUT,3/4,ACME THRD
17	TF4333A	2	GROUND ROLLER ADJ BRKT
18	6T2294	8	PLOW BOLT,1/2 x 2,NC
19	TF4336	4	PLATE,GROUND ROLLER LOCK
20	21730	5	CAPSCREW,1/2 x 1-1/4,NC
21	TF4371	1	SKID SHOE,L/PROFILE-OUTER
22	TF1702	1	BAFFLE,FLAIL,102,HD
23	6T2283	10	CARRIAGE BOLT,3/8 x 1,NC
24	28999	1	GROUND ROLLER,102
25	TF1045B	2	GRND ROLLER STUB SHAFT
26	6T2330	8	CAPSCREW, 7/16 x 1-1/2, SKT HD
27	06530217	8	CAPSCREW,1/2 x 2,NC,L9
28	06533006	8	FLATWASHER,1/2,SAE,L9
29	TF1018	2	BEARING,FLANGE,2-3/16
30	31204	2	STRING GUARD,HD
31	TF1707C	1	CUTTERSHAFT ASSY,102,HD
32	30411	56	KNIFE MOUNTING BOLT,FLAIL
33	TF1020	56	KNIFE MTG CLEVIS,FLAIL
34	33714	112	KNIFE,FLAIL,STANDARD
35	21677	56	NYLOCK NUT,7/16,NC
36	TF4365	1	SKID SHOE,L/PROFILE-INNER
37	TF1701	1	FRONT TRASH GUARD
38	06530001	12	CAPSCREW,SKT HD
39	06520027	2	CAP,BEARING
40	06520029	2	O-RING,2-3/4 x 3/32
41	06520028	2	BEARING,FLANGE,1-3/8
42	6T2331	8	CAPSCREW,7/16 x 1,SKT HD

HVY DUTY 102" REAR FLAIL DRIVE ASSEMBLY

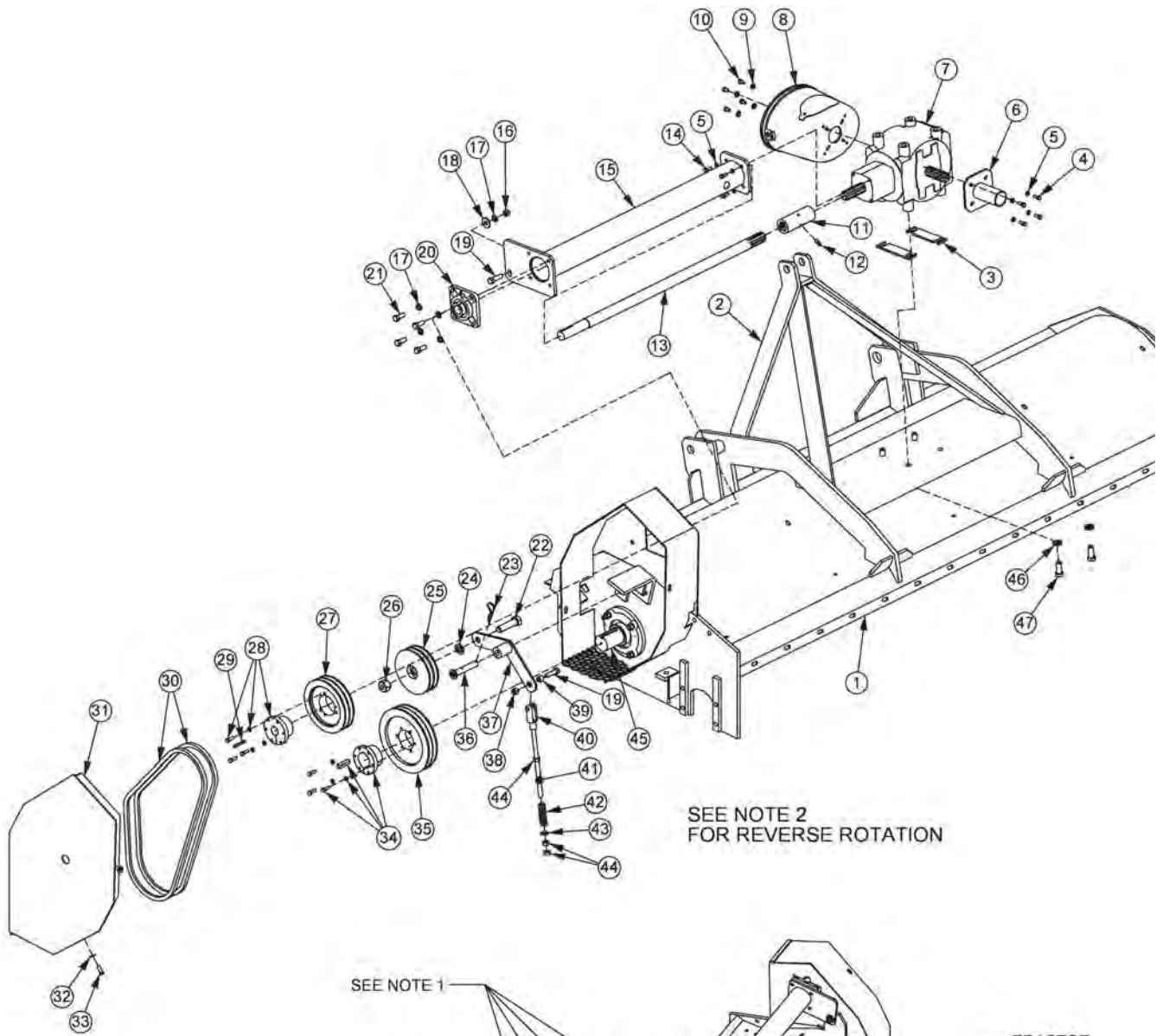

NOTE:

1. LOCATE AND FIT HITCH PER DRIVE ASSEMBLY PRIOR TO WELDING 3 POINT HITCH TO FLAIL BONNET
2. REVERSE ROTATION ASSEMBLY - PULLEY HARDWARE (ITEMS 22, 24, 25 & 26) SWAP ENDS WITH TENSIONER HARDWARE (ITEMS - 19, 38, 39, 40, 41, 42 & 43) ON IDLER ARM ITEM - 37

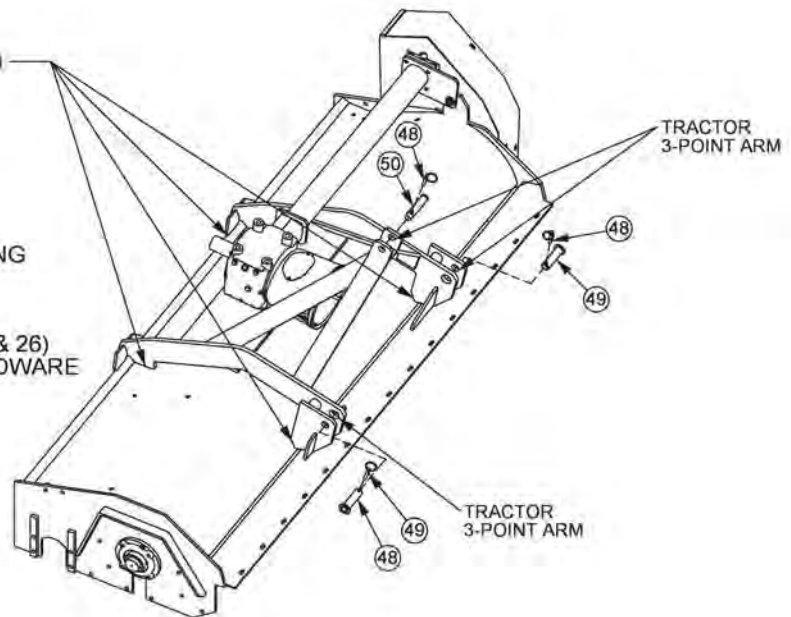

102" REAR FLAIL DRIVE ASSEMBLY

ITEM	P/N	QTY	DESCRIPTION
1	22046J	1	BONNET,102,HD
2	31279A	1	HITCH,3-POINT
3	40454	2	SPACER
4	27508	4	CAPSCREW,8MMx20MM(1.25)
5	6T2619	8	LOCKWASHER,8MM
6	28447E	1	GUARD,OUTPUT SHAFT
7	28505	1	GEARBOX,REAR FLAIL,COMER T22A
8	06520181	1	GUARD,PTO,GRBX
9	34948	4	FLATWASHER,8MM
10	27507	4	CAPSCREW,8MMx15MM(1.25)
11	28914	1	COUPLING,6 SPLINE
12	6T3209	1	GREASE ZERK,1/4 DRIVE
13	28421A	1	OUTPUT EXTENSION SHAFT,102RCM
	28417B	*	OUTPUT EXTENSION SHAFT,102R6F
	28419B	*	OUTPUT EXTENSION SHAFT,102OFF
14	30162	4	CAPSCREW,SKT HD,8MMx20MM(1.25)
15	28429A	1	SHAFT GRD,HD,102RCM
	28425B	*	SHAFT GRD,HD,102R6F
	28427B	*	SHAFT GRD,HD,102ROFF
16	21725	1	HEX NUT,1/2,NC
17	21990	5	LOCKWASHER,1/2
18	22018	1	FLATWASHER,1/2,WIDE
19	21732	2	CAPSCREW,1/2x1-3/4,NC
20	28571	1	BEARING,FLANGE,1-1/4
21	21730	4	CAPSCREW,1/2x1-1/4,NC
22	28399	1	CAPSCREW,20MMx80MM(2.5),GR10.9
23	6T3004	1	R-CLIP,HAIRPIN COTTER,3/16
24	24881	1	LOCKWASHER,20MM
25	31295	1	SHEAVE,IDLER ASSY,6.3
26	31740	1	NYLOCK NUT,20MM(2.5)
27	TF3043	1	SHEAVE,7.5
28	30049	2	BUSHING,QD,SK 1-1/4,1/4 KEY
29	28572	1	KEY,1/4SQ x 2
30	TF3023	2	V-BELT(630)
31	31286A	1	SHIELD,BELT
32	21988	4	LOCKWASHER,3/8
33	21630	4	CAPSCREW,3/8x1,NC
34	TF3011	1	BUSHING,QD,SK 2-3/16
35	28570	1	SHEAVE,9.0
36	TF3605	1	PIN,IDLER ARM
37	TF1180	1	IDLER ARM
38	6T2418	1	HEX NUT,1/2,NC,GR8(STOVER)
39	TF3610	1	BUSHING,IDLER
40	PT3611A	1	CLEVIS
41	32482	1	ROD,THREADED,1/2-20,NF,12-1/2
42	TF3620A	1	SPRING,TENSIONER
43	27938	1	BUSHING,MACH,14GA
44	21700	3	HEX NUT,1/2,NF
45	TF1102A	1	CUTTERSHAFT W/ KNIVES
46	6T2625	4	LOCKWASHER,16MM
47	22421	4	CAPSCREW,16MMx40MM(2.0),GR10.9
48	TF1143	3	LYNCH PIN
49	TF1120	2	PIN,CAPPED
50	TB1036	1	PIN

STD DUTY REAR GEAR BOX ASY (REAR ONLY)

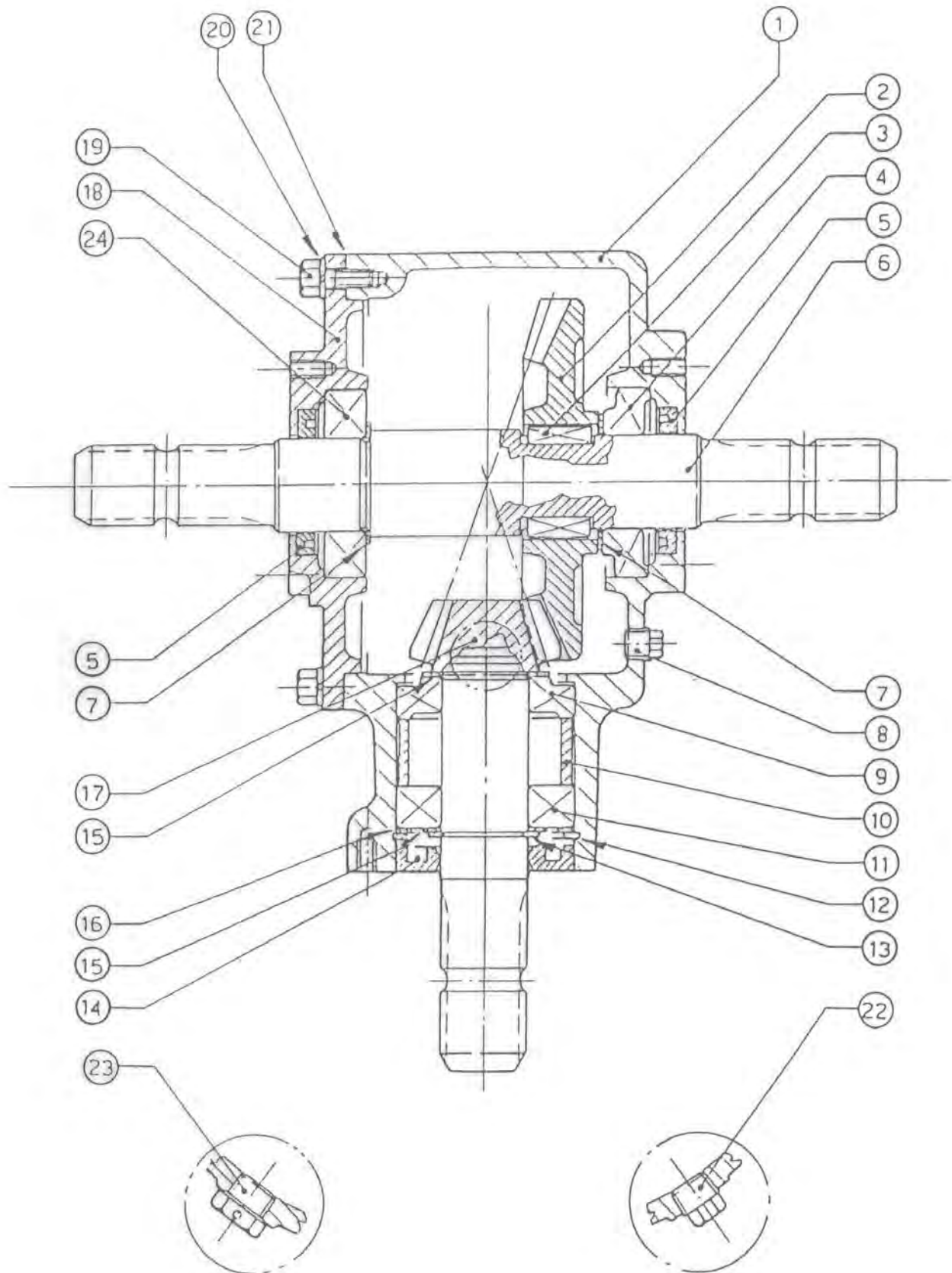

STD DUTY REAR GEAR BOX ASY (REAR ONLY)

ITEM	P/N	QTY	DESCRIPTION
1	30133	1	CASING,T4A GEARBOX
2	30134	1	CROWNWHEEL 230,T4A GEARBOX
3	30135	2	PARALLEL KEY,T4A GEARBOX
4	28604	1	BEARING
5	30136	2	OIL SEAL
6	30137	1	SHAFT
7	28603	2	SHIM
8	30138	1	PLUG
9	30139	1	BEARING,30207
10	30140	1	SPACER
11	30141	1	BEARING 6207
12	30142	1	INTERNAL CIRCLIP 72
13	30143	1	EXTERNAL CIRCLIP 72
14	30144	1	OIL SEAL,35X72X10
15	30145	2	SHIM,T4A GEARBOX
16	30146	1	SHIM,T4A GEARBOX
17	30147	1	PINION 210,T4A GEARBOX
18	30148	1	COVER,T4A GEARBOX
19	30149	6	HEX BOLT M8X22
20	30150	6	SINGLE COIL WASHER 8.1
21	30151	1	SEAL,T4A GEARBOX
22	30152	1	PLUG,T4A GEARBOX
23	30153	1	OIL FILTER PLUG,T4A GEARBOX
24	30154	1	BEARING 6208

HVY DUTY REAR GEAR BOX ASY (REAR ONLY)

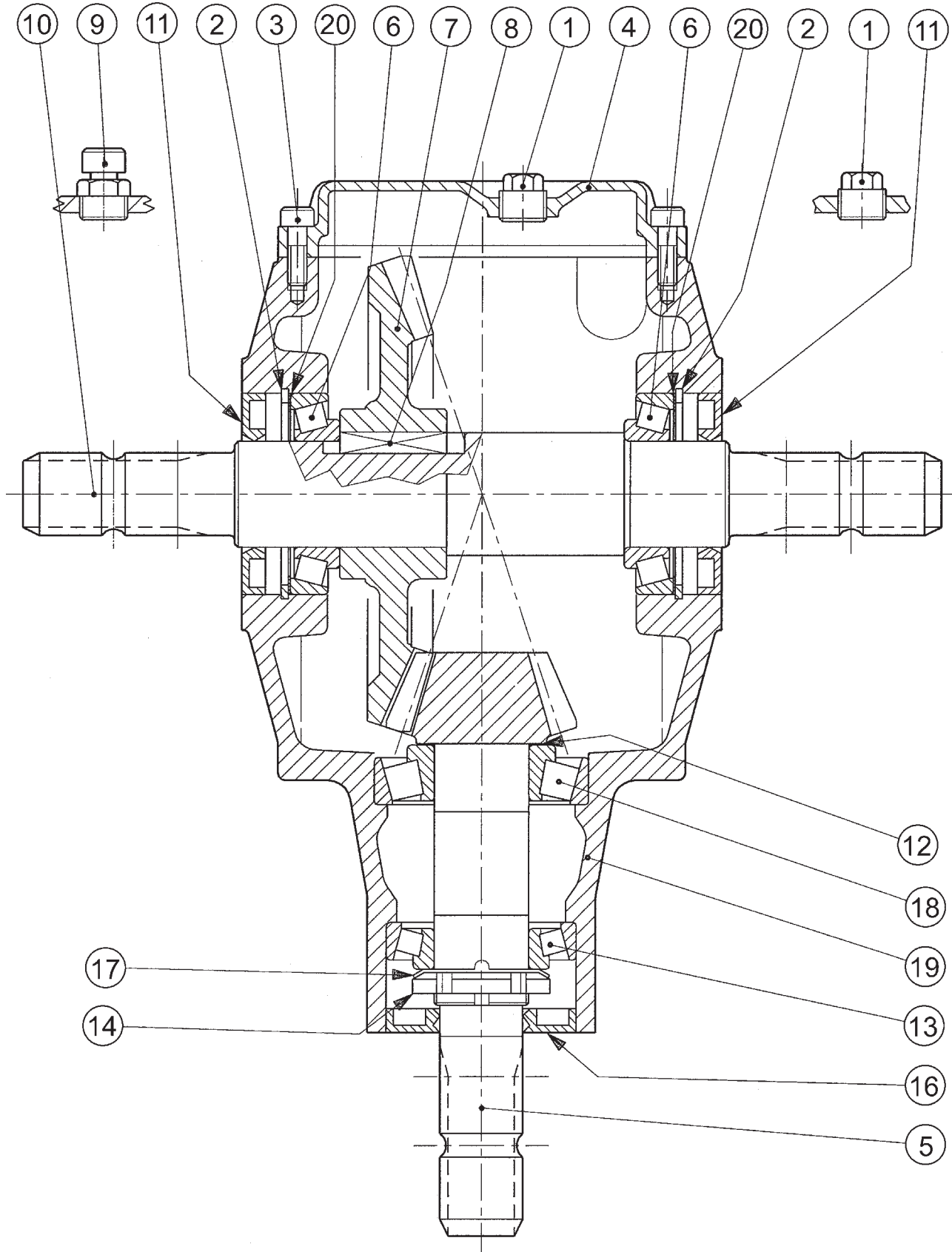

HVY DUTY REAR GEAR BOX ASY (REAR ONLY)

ITEM	P/N	QTY	DESCRIPTION
1	28592	2	PLUG 1/2" GAS
2	28593	2	SNAP RING
3	28594	6	BOLT 8MM X 25MM
4	28595	1	SHIM
6	28597	2	BEARING
7	28598	1	GEAR
8	28599	1	PARALLELL KEY
9	28600	1	OIL FILLER PUG
10	28601	1	SHAFT
11	28602	2	OIL SEAL
12	28603	1	SHIM
13	28604	1	BEARING
14	28605	1	LOCK NUT
15	28606	1	PINION
16	28607	1	DOUBLE LIP SEAL
17	28608	1	SPRING WASHER
18	28609	1	BEARING
19	28591	1	CASTING
20	28596	2	SHIM

PTO SHAFT ASSY (06520414)

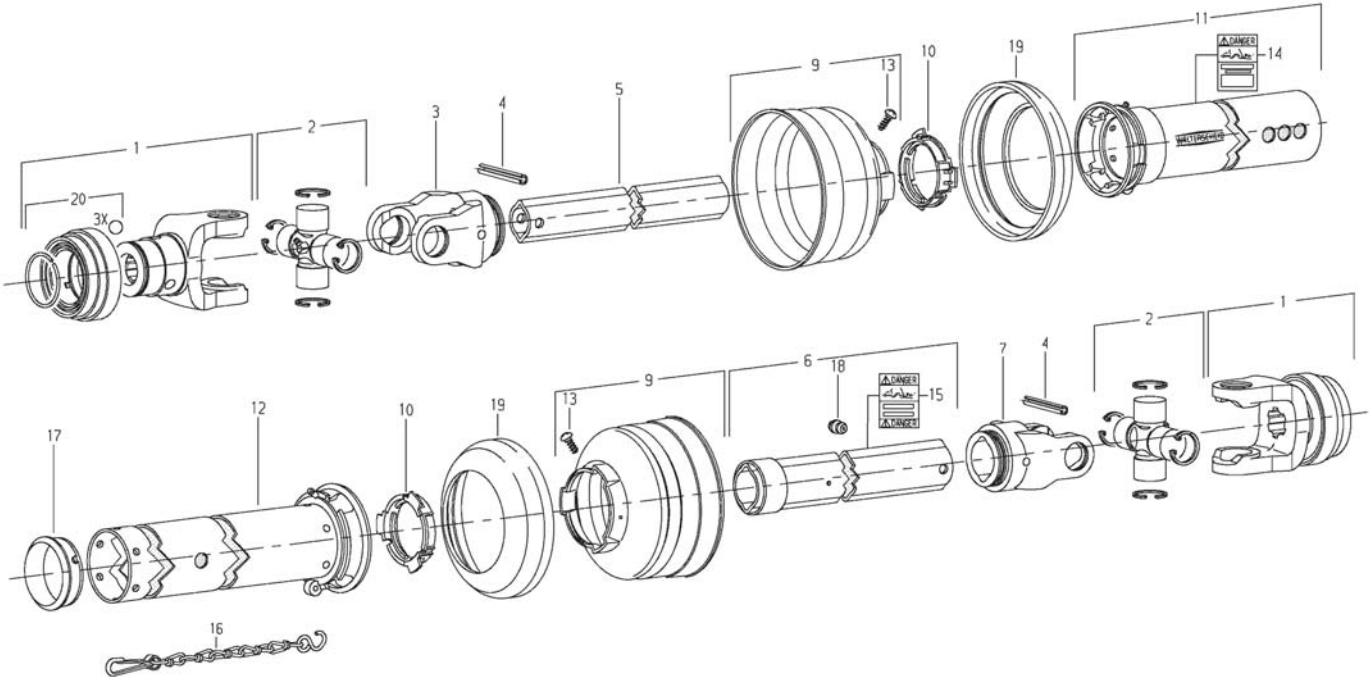

ITEM	P/N	QTY	DESCRIPTION
	06520414	REF	PTO,DRV SHFT,TRF
1	00775353	2	YOKE 1-3/8"-6 SPL.
2	00189700	2	CROSS & BEARING KIT
3	00775317	1	INBOARD YOKE 1b
4	00756934	2	SPRING PIN
5	*	1	INNER PROFILE 1b
6	*	1	PROFILE & SLEEVE
7	00775318	1	INBOARD YOKE 2a
9	06505010	2	GUARD CONE
10	8393	2	BEARING RING
11	*	1	GUARD TUBE, OUTER
12	*	1	GUARD TUBE, INNER
13	00759217	2	SCREW (ITEM 9)
14	00756005	1	DECAL, OUTER (ITEM 11)
15	00756004	1	DECAL, INNER (ITEM 6)
16	1416412	1	RESTRAINT CHAIN
17	*	1	SUPPORT BEARING
18	*	1	ZERK (ITEM 6)
19	*	2	REINFORCING COLLAR
20	00767954	AVAIL	KIT, COLLAR (ITEM 1)

PTO SHAFT ASSY WITH CLUTCH (06520415)

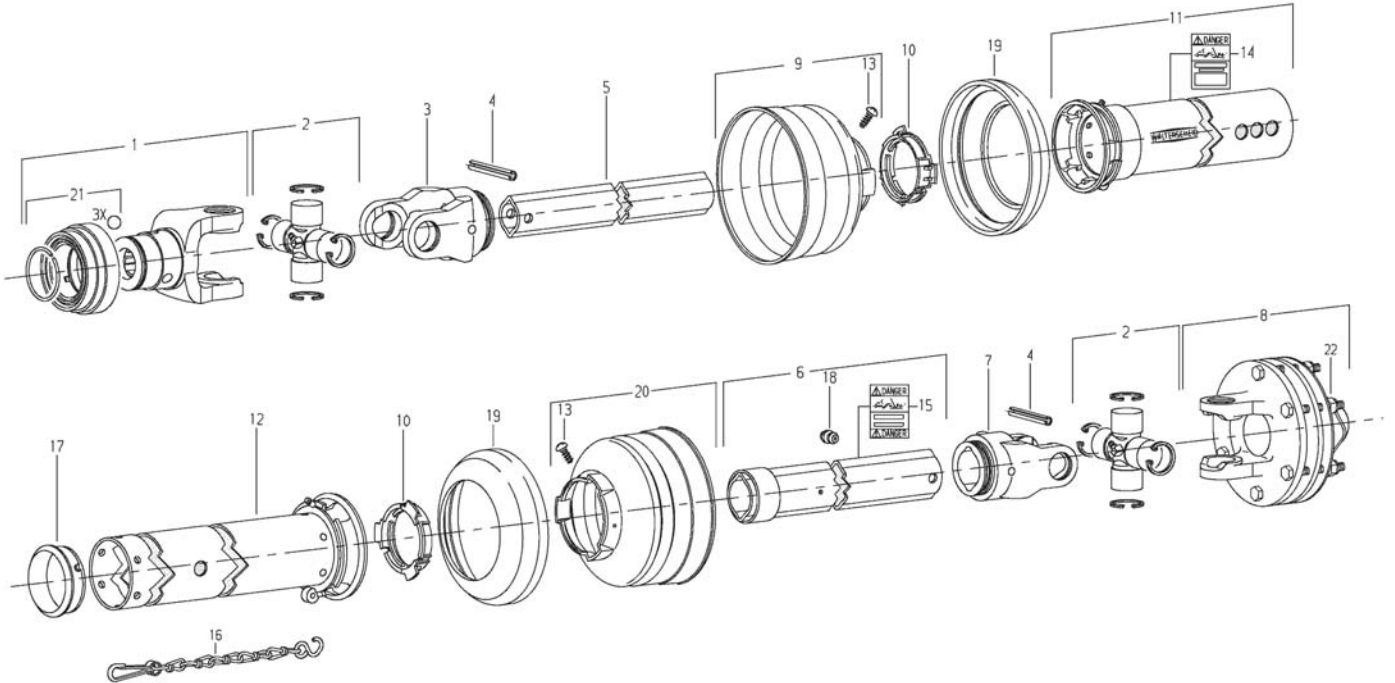

ITEM	P/N	QTY	DESCRIPTION
	06520415	REF	PTO,DRV SHFT,TRF,CLUTCH
1	00775353	1	YOKE 1-3/8"-6 SPL.
2	00189700	2	CROSS & BEARING KIT
3	00775317	1	INBOARD YOKE 1b
4	00756934	2	SPRING PIN
5	*	1	INNER PROFILE 1b
6	*	1	PROFILE & SLEEVE
7	00775318	1	INBOARD YOKE 2a
8	00775365	1	FRICTION CLUTCH
9	06505010	2	GUARD CONE
10	8393	2	BEARING RING
11	*	1	GUARD TUBE, OUTER
12	*	1	GUARD TUBE, INNER
13	00759217	2	SCREW (ITEM 9)
14	00756005	1	DECAL, OUTER (ITEM 11)
15	00756004	1	DECAL, INNER (ITEM 6)
16	1416412	1	RESTRAINT CHAIN
17	*	1	SUPPORT BEARING
18	*	1	ZERK (ITEM 6)
19	*	2	REINFORCING COLLAR
20	*	1	GUARD CONE
21	00767954	AVAIL	KIT, COLLAR (ITEM 1)
22	0921000470	AVAIL	KIT, FLANGE (ITEM 8)

CLUTCH ASSY (00775365)

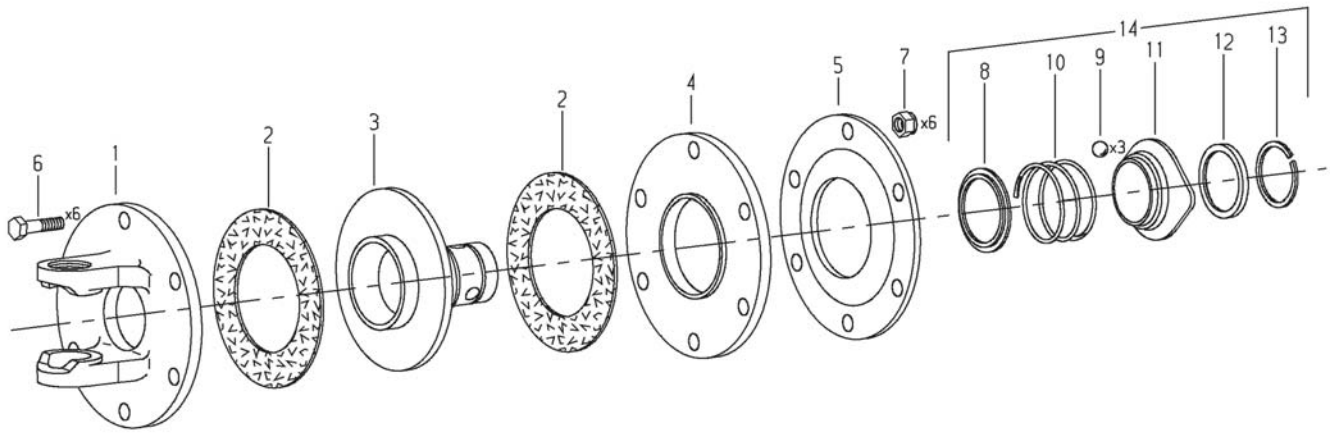

ITEM	PART NO.	QTY.	DESCRIPTION
	00775365	—	CLUTCH ASSY
1	*	1	FLANGE YOKE
2	*	2	FRICTION DISC
3	*	1	HUB
4	*	1	THRUST PLATE
5	*	1	BELLE VILLE SPRING
6	*	6	HEX BOLT
7	*	6	HEX LOCKNUT
8	*	1	BACK-UP RING
9	*	3	BALL
10	*	1	COMPRESSION SPRING
11	*	1	LOCK COLLAR
12	*	1	BACK-UP RING
13	*	1	SNAP RING
14	0921000470	AVAIL	KIT (ITEMS 8 THRU 13)

**PAGE
INTENTIONALLY
LEFT
BLANK**

RESERVOIR TANK FILTER ASSEMBLY

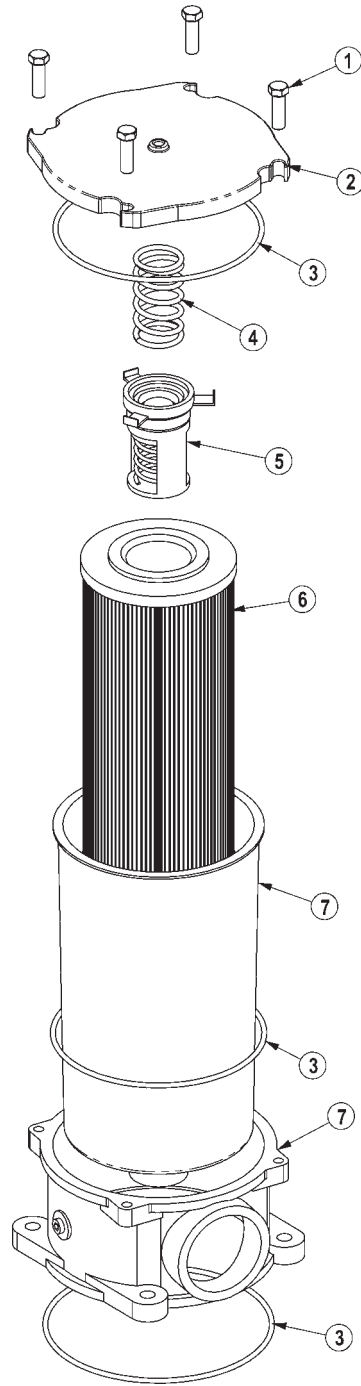

ITEM	PART NO.	QTY.	DESCRIPTION
	06505044	AVAIL	FILTER ASSY SAE 10 MICRON
1	28583	4	CAPSCREW,8MMX25MM(1.25 PITCH)
2	06505045	1	COVER
3	06505046	1	SEAL KIT
4	06505047	1	SPRING
5	06505048	1	BYPASS
6	35259	1	FILTER,10 MIC,RETURN LINE
7	06505049	1	CAN/BODY

FRONT PUMP ASY

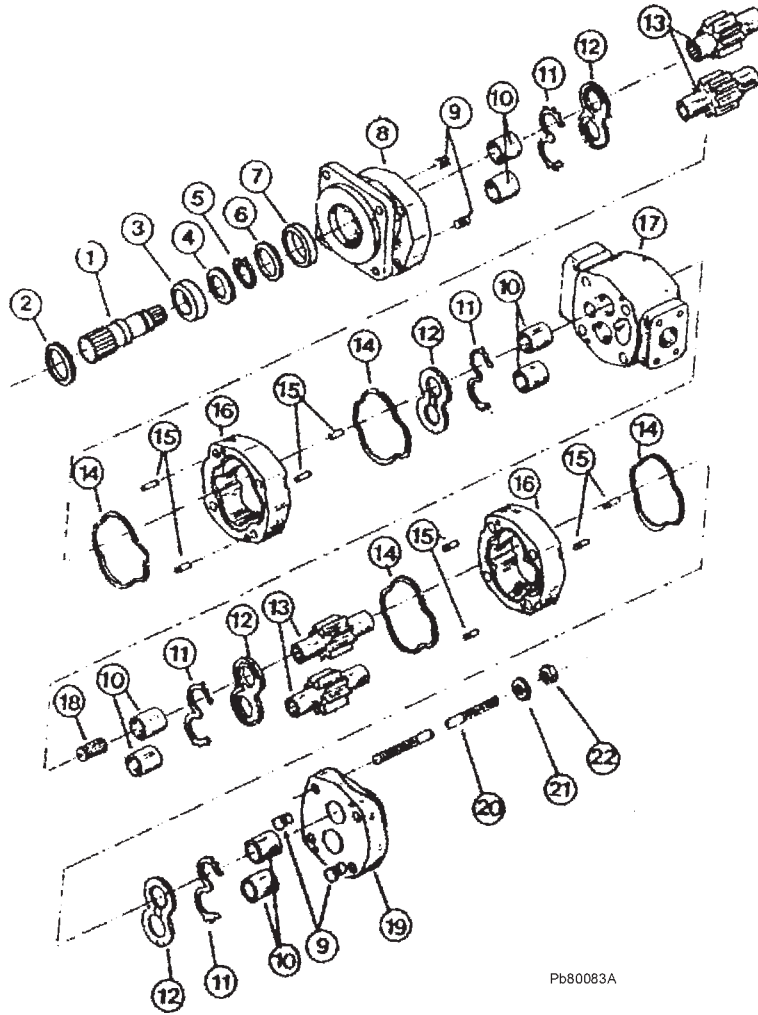

Pb80083A

ITEM	P/N	QTY	DESCRIPTION
	TF4450	AVAIL	FRONT MOUNTED PUMP P330
1	TF4459	1	CONTINENTAL SHAFT
2	TF4451	1	SNAP RING
3	TF4452	1	OUTBOARD BEARING
4	TF4467	1	BEARING RETAINER RING
5	TF4472	1	RETAINING RING
6	TF4473	1	SPACER
7	TF4453	1	LIP SEAL
8	TF4454	1	SHAFT END COVER
9	TF4455	4	PLUG
10	TF4456	8	BUSHING
11	TF4457	4	CHANNEL SEAL
12	TF4458	4	THRUST PLATE
13	TF4466	2 SET	MATCHED GEAR SET
14	TF4460	4	GASKET SEAL
15	TF4461	8	DOWEL PINS
16	TF4462	2	GEAR HOUSING (FOR 1 1/2" GEARS)
17	TF4463	1	BEARING CARRIER
18	TF4465	1	CONNECTING SHAFT
19	TF4468	1	PORT END COVER
20	TF4469	4	STUD
21	TF4415	4	WASHER
22	TF4471	4	NUT
	TF4474	AVAIL	SEAL KIT (INCLUDES ITEM 7, 11, AND 14)

SIDE DECK MOTOR – HIGH PRESSURE

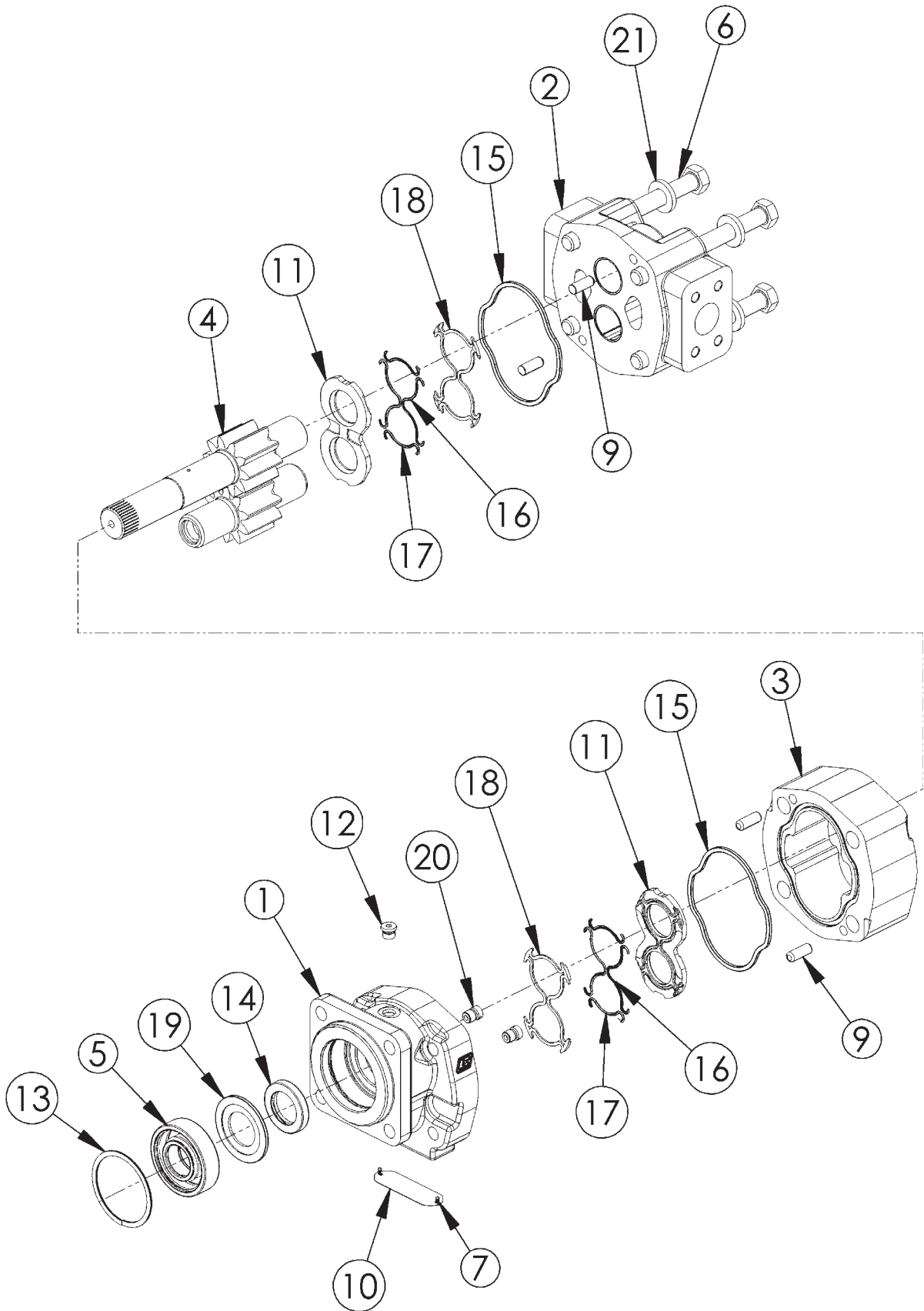

SIDE DECK MOTOR – HIGH PRESSURE

ITEM	PART NO.	QTY.	DESCRIPTION
*	06504066	AVAIL	MOTOR ASSEMBLY 350 - T3F
1	06504039	1	SHAFT END COVER
2	06504054	1	PORT END COVER
3	06504055	1	GEAR HOUSING
4	06504056	1	MATCHED GEAR SET
5	TF4402	1	BALL BEARING
6	06504057	4	CAP SCREW
7	06504044	2	SET SCREW
9	06504045	4	DOWEL PIN
10		1	NAMEPLATE
11	763759	2	THRUSTPLATE
12	02961940	1	HEX PLUG
13	TF4401	1	SNAP RING
14	06504049	1	LIP SEAL (INCLUDED IN SEAL KIT)
15	TF4410	2	GASKET SEAL (INCLUDED IN SEAL KIT)
16	06504046	4	SIDE SEAL (INCLUDED IN SEAL KIT)
17	06504047	4	END SEAL (INCLUDED IN SEAL KIT)
18	TF4407	2	BACK-UP SEAL (INCLUDED IN SEAL KIT)
19	02961932	1	SEAL RETAINER
20	6T5809	2	CHECK ASSEMBLY
21	02961917	4	WASHER
*	06504023	AVAIL	SEAL KIT (INCLUDES 14, 15, 16, 17, AND 18)

ITEM	PART NO.	QTY.	DESCRIPTION
*	06504065	AVAIL	MOTOR ASSEMBLY 350 - T3F STD DUTY
1	06504039	1	SHAFT END COVER
2	06504060	1	PORT END COVER
3	06504055	1	GEAR HOUSING
4	06504056	1	MATCHED GEAR SET
5	TF4402	1	BALL BEARING
6	06504057	4	CAP SCREW
7	06504044	2	SET SCREW
9	06504045	4	DOWEL PIN
10		1	NAMEPLATE
11	763759	2	THRUSTPLATE
12	02961940	1	HEX PLUG
13	TF4401	1	SNAP RING
14	06504049	1	LIP SEAL (INCLUDED IN SEAL KIT)
15	TF4410	2	GASKET SEAL (INCLUDED IN SEAL KIT)
16	06504046	4	SIDE SEAL (INCLUDED IN SEAL KIT)
17	06504047	4	END SEAL (INCLUDED IN SEAL KIT)
18	TF4407	2	BACK-UP SEAL (INCLUDED IN SEAL KIT)
19	02961932	1	SEAL RETAINER
20	6T5809	2	CHECK ASSEMBLY
21	02961917	4	WASHER
*	06504023	AVAIL	SEAL KIT (INCLUDES 14, 15, 16, 17, AND 18)

SIDE DECK MOTOR – HIGH PRESSURE

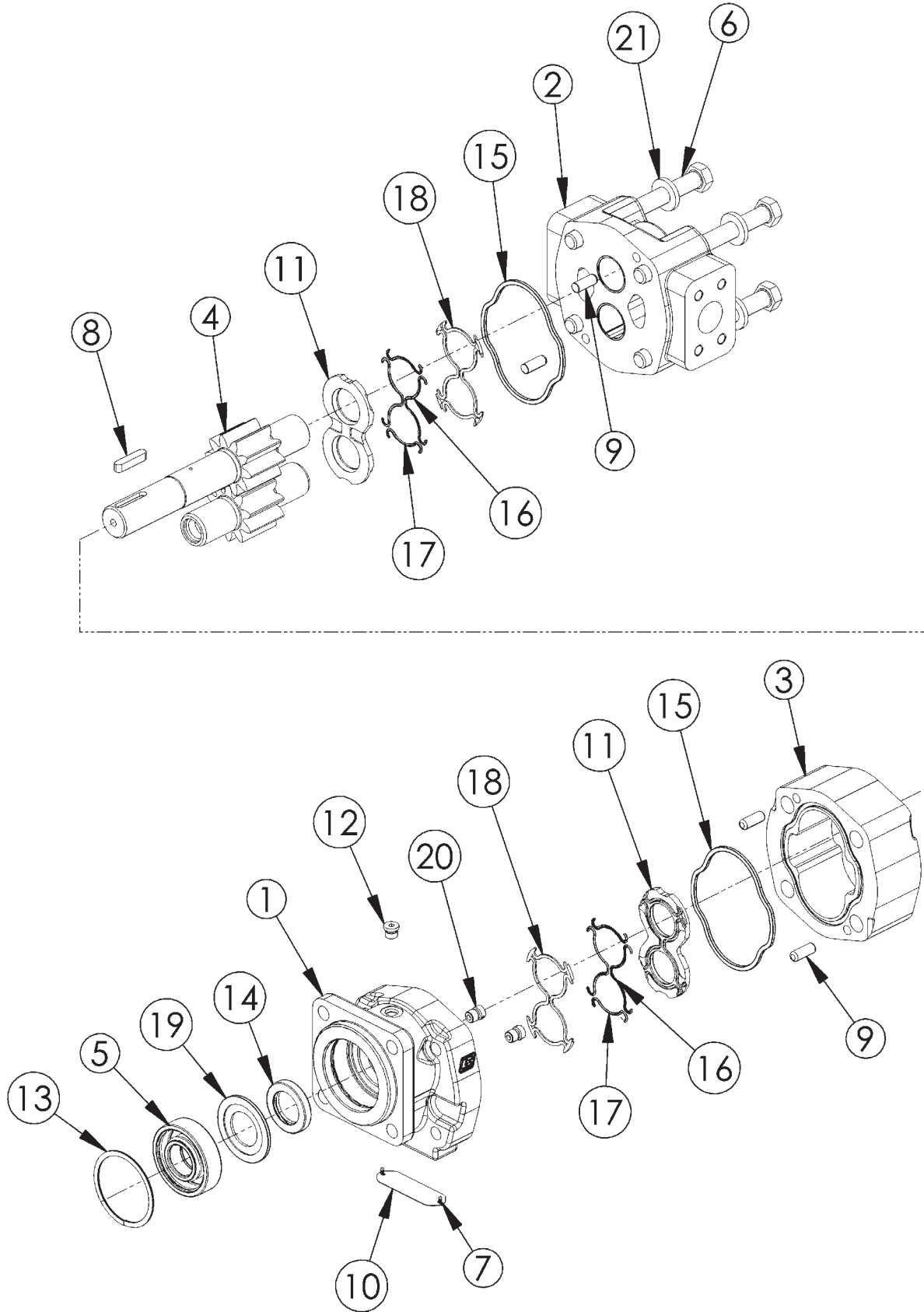

SIDE DECK MOTOR – HIGH PRESSURE

ITEM	PART NO.	QTY.	DESCRIPTION
*	06504013	AVAIL	MOTOR ASSEMBLY 350 - TSF
1	06504039	1	SHAFT END COVER
2	06504040	1	PORT END COVER
3	06504041	1	GEAR HOUSING
4	06504042	1	MATCHED GEAR SET
5	TF4402	1	BALL BEARING
6	06504043	4	CAP SCREW
7	06504044	2	SET SCREW
8	06504028	1	KEY
9	06504045	4	DOWEL PIN
10		1	NAMEPLATE
11	763759	2	THRUSTPLATE
12	02961940	1	HEX PLUG
13	TF4401	1	SNAP RING
14	06504049	1	LIP SEAL (INCLUDED IN SEAL KIT)
15	TF4410	2	GASKET SEAL (INCLUDED IN SEAL KIT)
16	06504046	4	SIDE SEAL (INCLUDED IN SEAL KIT)
17	06504047	4	END SEAL (INCLUDED IN SEAL KIT)
18	TF4407	2	BACK-UP SEAL (INCLUDED IN SEAL KIT)
19	06504048	1	SEAL RETAINER
20	6T5809	2	CHECK ASSEMBLY
21	02961917	4	WASHER
*	06504023	AVAIL	SEAL KIT (INCLUDES 14, 15, 16, 17, AND 18)

HYDRAULIC LIFT CYLINDER

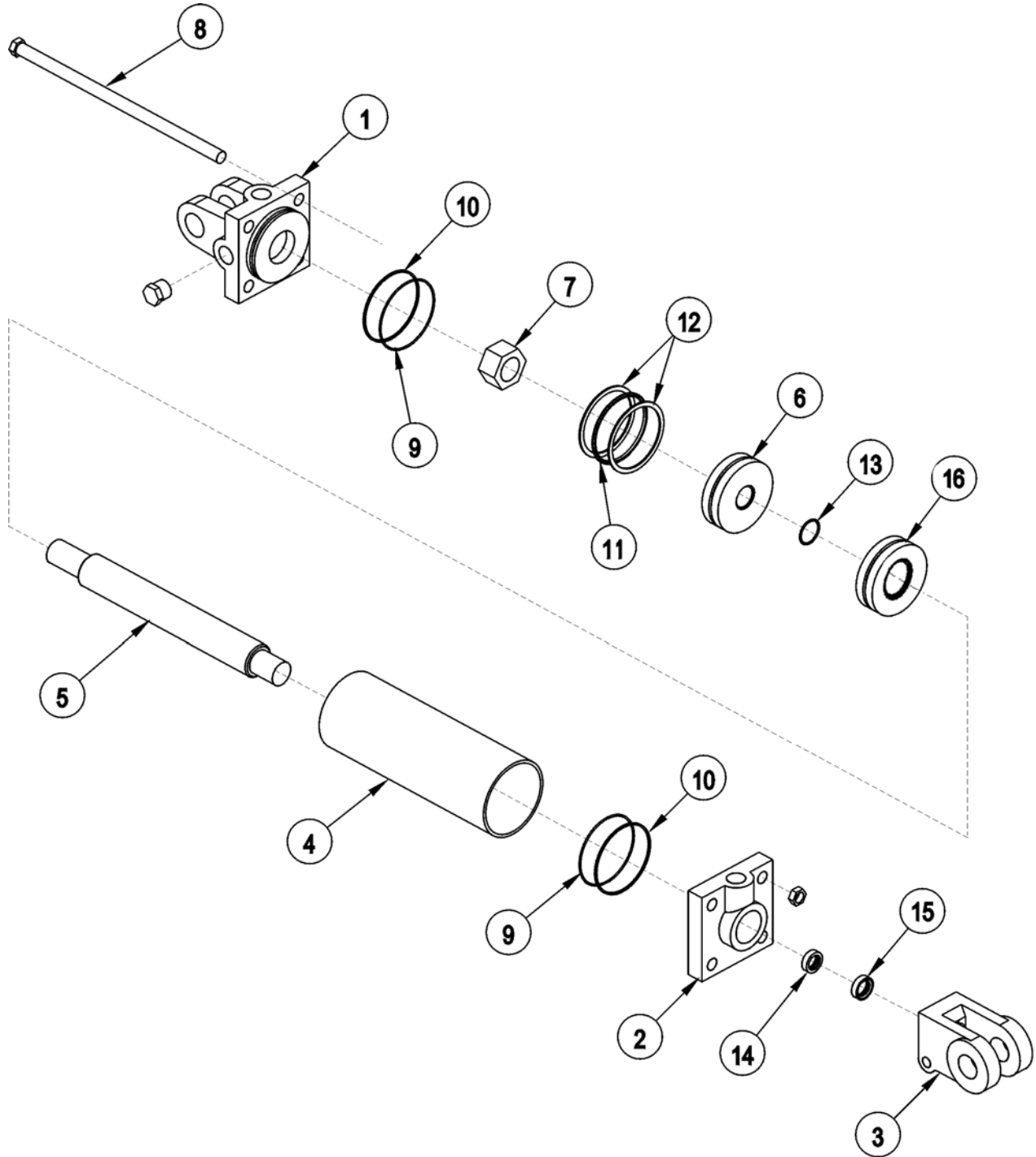

Tb1015

HYDRAULIC LIFT CYLINDER

3" X 10" CYLINDER #6T0151R

ITEM	PART NO.	QTY.	DESCRIPTION
1	6T0167	1	CYLINDER BUTT
2	6T0170	1	CYLINDER GLAND
3	6T0178	1	CLEVIS END
4	6T0164	1	CYLINDER TUBE
5	6T0161	1	PISTON ROD
6	6T0173	1	PISTON
7	6T0179	1	LOCKNUT
8	6T0176	4	TIE RODASY
	6T0187	AVAIL	SEAL KIT
9		2	O - RING
10		2	BACK - UP WASHER
11		1	O - RING
12		2	BACK - UP WASHER
13		1	O - RING
14		1	U - CUP
15		1	WIPER

3" X 11.5" CYLINDER #25343

ITEM	PART NO.	QTY.	DESCRIPTION
1	6T0167	1	CYLINDER BUTT
2	6T0170	1	CYLINDER GLAND
3	6T0178	1	CLEVIS END
4	23870	1	CYLINDER TUBE
5	23869	1	PISTON ROD
6	6T0173	1	PISTON
7	6T0179	1	LOCKNUT
8	21749	1	TIE RODASY
	6T0187	AVAIL	SEAL KIT
9		2	O - RING
10		2	BACK - UP WASHER
11		1	O - RING
12		2	BACK - UP WASHER
13		1	O - RING
14		1	U - CUP
15		1	WIPER

HYDRAULIC LIFT CYLINDER

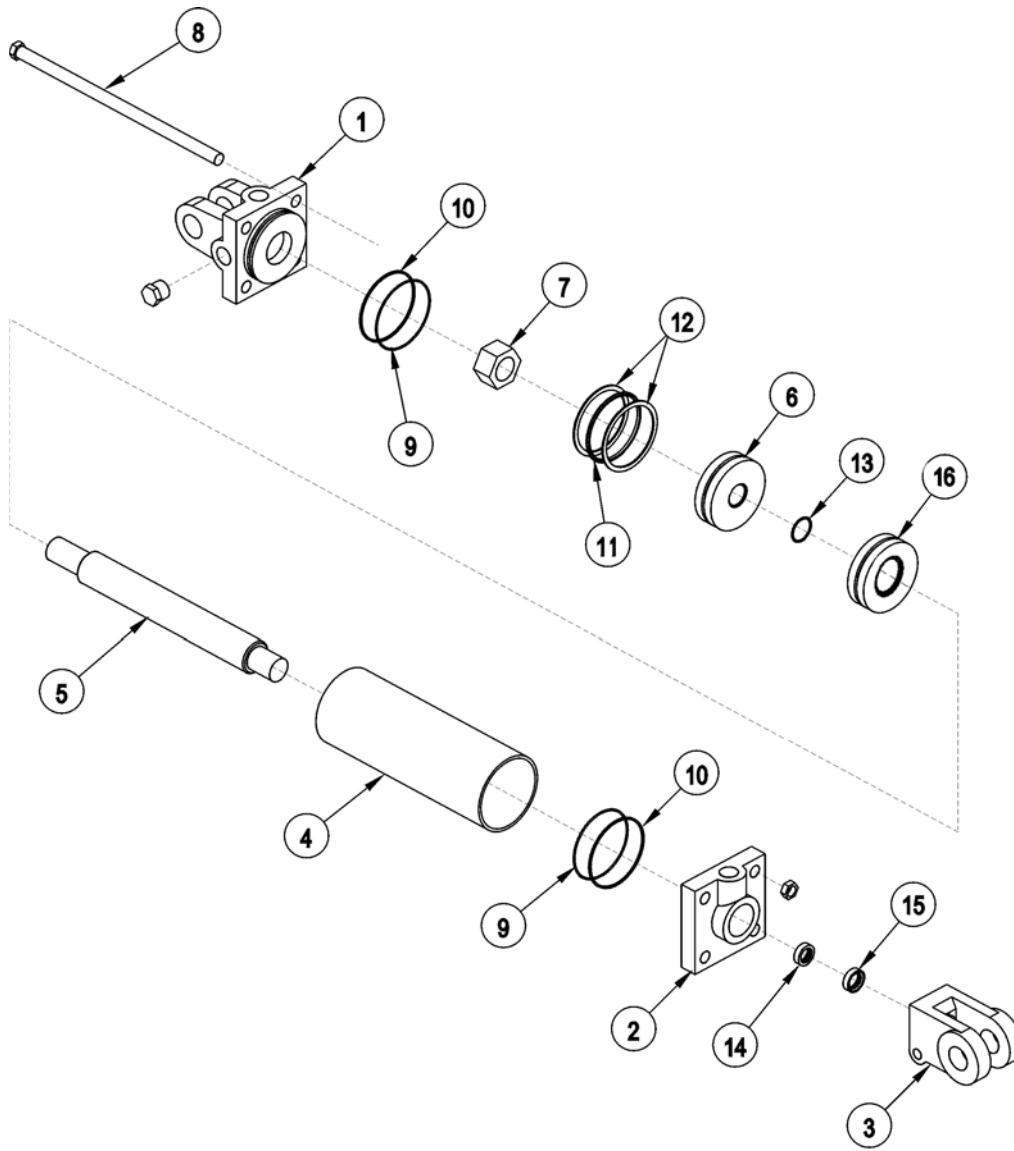

Tb1015

HYDRAULIC LIFT CYLINDER

3" X 8" CYLINDER # 31211

ITEM	P/N	QTY	DESCRIPTION
1	6T0167	1	CYLINDER BUTT
2	6T0170	1	CYLINDER GLAND
3	6T0178	1	CLEVIS END
4	23870	1	CYLINDER TUBE
5	23869	1	PISTON ROD
6	6T0173	1	PISTON
7	6T0179	1	LOCKNUT
8	21749	4	TIE ROD ASY
	6T0187	AVAIL	SEAL KIT
9		2	O - RING
10		2	BACK - UP WASHER
11		1	O - RING
12		2	BACK - UP WASHER
13		1	O - RING
14		1	U - CUP
15		1	WIPER

3" X 12" CYLINDER # 32215

ITEM	P/N	QTY	DESCRIPTION
1	6T0167	1	CYLINDER BUTT
2	6T0170	1	CYLINDER GLAND
3	6T0178	1	CLEVIS END
4	6T0204	1	CYLINDER TUBE
5	6T0203	1	PISTON ROD
6	6T0173	1	PISTON
7	6T0179	1	LOCKNUT
8	6T0205	1	TIE ROD ASY
	6T0187	AVAIL	SEAL KIT
9		2	O - RING
10		2	BACK - UP WASHER
11		1	O - RING
12		2	BACK - UP WASHER
13		1	O - RING
14		1	U - CUP
15		1	WIPER

4SP HUSCO VALVE - LOAD SENSE (31190)

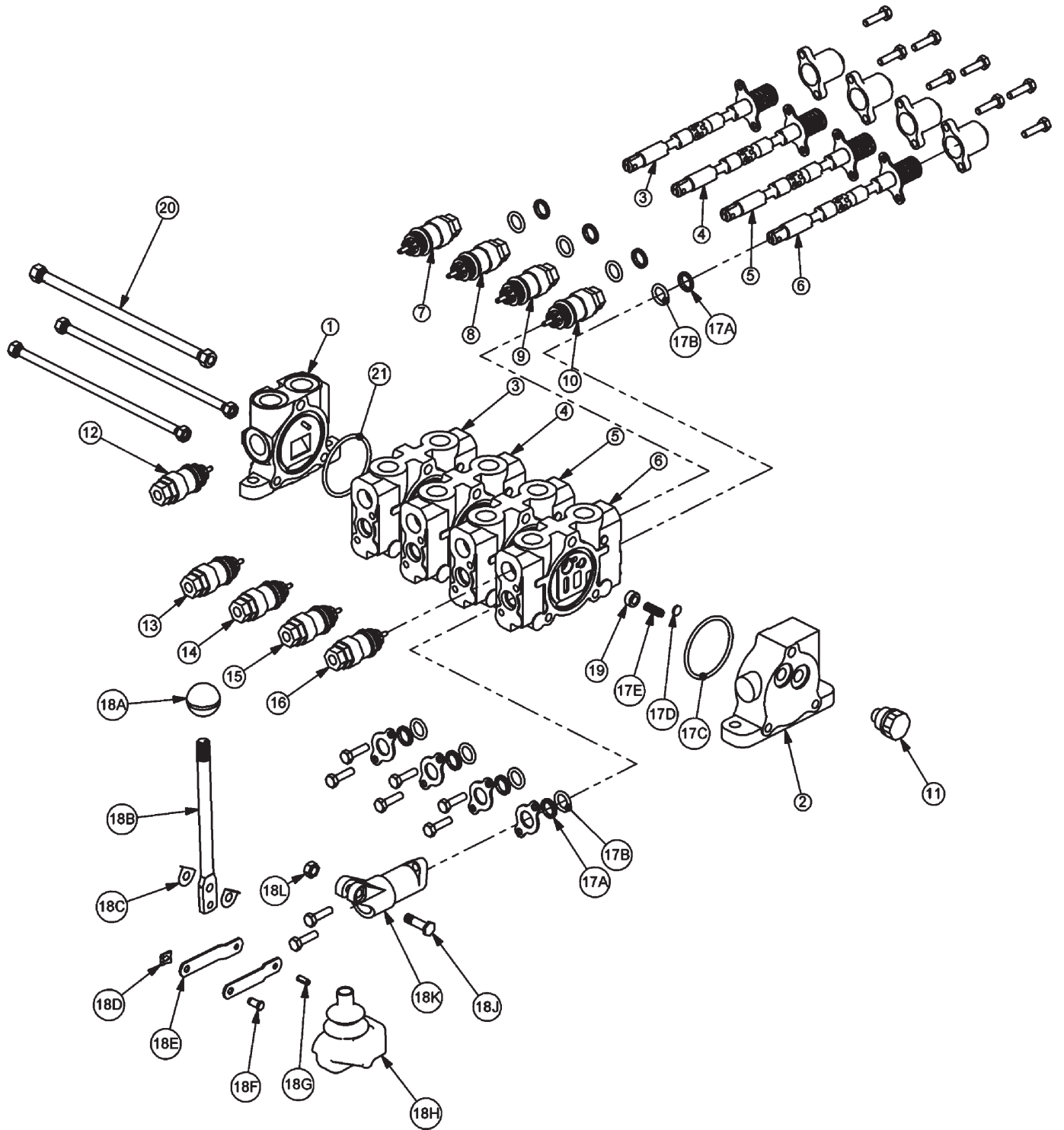

4SP HUSCO VALVE - LOAD SENSE (31190)

ITEM	PART NO.	QTY	DESCRIPTION
1	31595	1	INLET END COVER
2	31594	1	END COVER, LOAD SENSE
3	31600	1	VALVE SECTION (DOUBLE ACTING, DETENT - FLOAT)
4	31600	1	VALVE SECTION (DOUBLE ACTING, DETENT - FLOAT)
5	31600	1	VALVE SECTION (DOUBLE ACTING, DETENT - FLOAT)
6	31600	1	VALVE SECTION (DOUBLE ACTING, DETENT - FLOAT)
7	31861	1	RELIEF VALVE, 360 PSI
8	06503067	1	RELIEF PLUG
9	06503067	1	RELIEF PLUG
10	31861	1	RELIEF VALVE, 360 PSI
11	06503068	1	RELIEF PLUG
12	6T4209	1	RELIEF PLUG
13	31862	1	RELIEF VALVE, 2175 PSI
14	31862	1	RELIEF VALVE, 2175 PSI
15	31862	1	RELIEF VALVE, 2175 PSI
16	31862	1	RELIEF VALVE, 2175 PSI
17	31593	4	VALVE SEAL KIT (FOR ONE SECTION)
17A		2	WIPER
17B		2	O-RING SMALL
17C		1	O-RING LARGE
17D		1	SHUTTLE DISC
17E		1	SPRING
18	TB1017L	4	LEVER KIT (FOR ONE SECTION)
18A		1	LEVER KNOB
18B		1	LEVER
18C		2	LEVER WASHER
18D		1	LEVER CLIP
18E		2	LINKAGE
18F		1	LEVER PIN
18G		1	ROLL PIN
18H		1	LEVER BOOT
18J		1	LEVER BOLT
18K		1	LEVER DUST COVER
18L		1	LEVER NUT
19	31603	4	COMPENSATOR
20	TB1017U	1	TIE ROD KIT
21	24214	1	O-RING, LARGE

4SP HUSCO VALVE - LOAD SENSE (06502046)

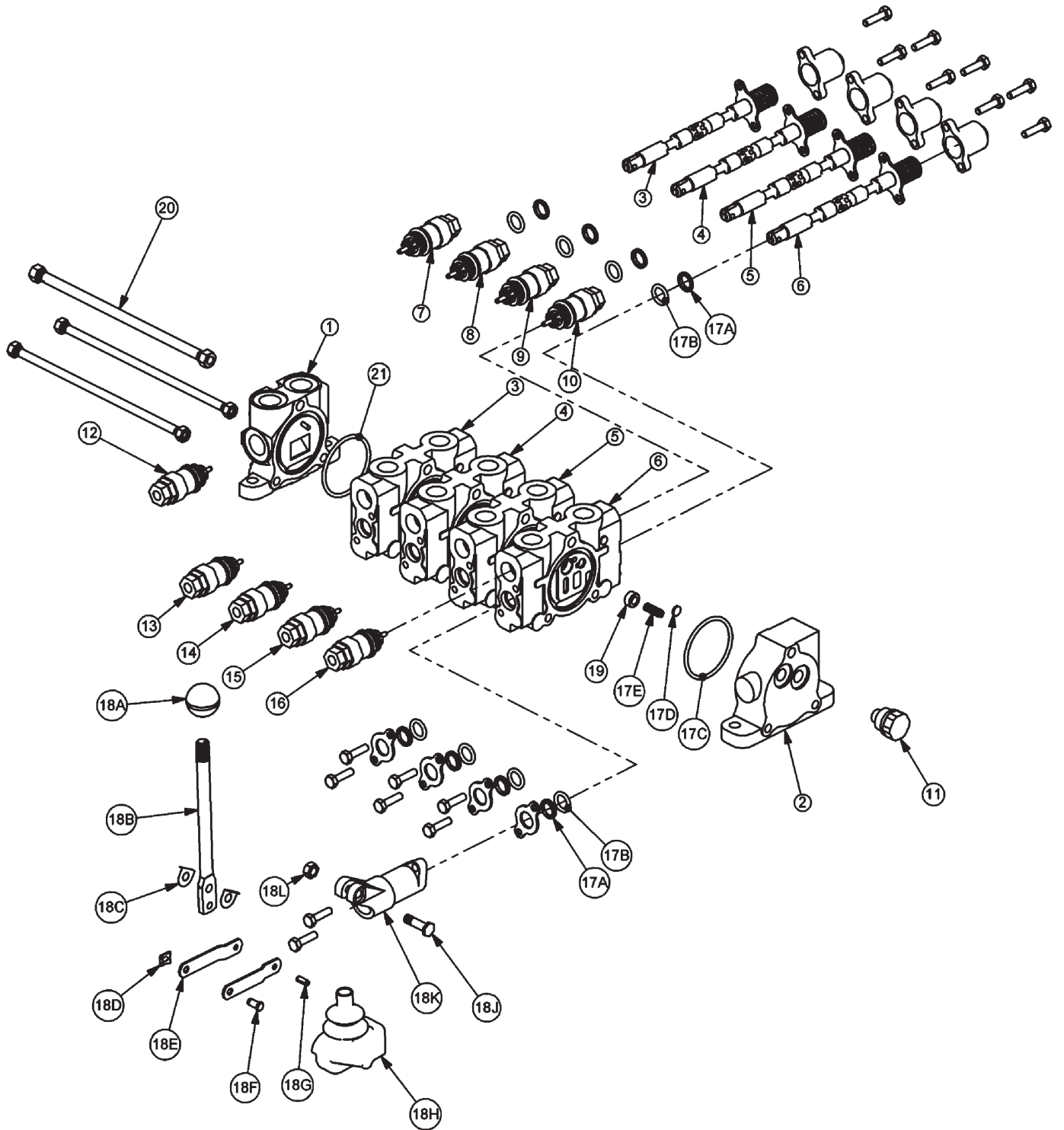

4SP HUSCO VALVE - LOAD SENSE (06502046)

ITEM	PART NO.	QTY	DESCRIPTION
1	31595	1	INLET END COVER
2	31594	1	END COVER, LOAD SENSE
3	31600	1	VALVE SECTION (DOUBLE ACTING, DETENT - FLOAT)
4	31600	1	VALVE SECTION (DOUBLE ACTING, DETENT - FLOAT)
5	31600	1	VALVE SECTION (DOUBLE ACTING, DETENT - FLOAT)
6	31600	1	VALVE SECTION (DOUBLE ACTING, DETENT - FLOAT) (REMOVE SHUTTLE DISC)
7	31861	1	RELIEF VALVE, 360 PSI
8	06503067	1	RELIEF PLUG
9	06503067	1	RELIEF PLUG
10	31861	1	RELIEF VALVE, 360 PSI
11	06503068	1	RELIEF PLUG
12	6T4209	1	RELIEF PLUG
13	31862	1	RELIEF VALVE, 2175 PSI
14	31862	1	RELIEF VALVE, 2175 PSI
15	31862	1	RELIEF VALVE, 2175 PSI
16	31862	1	RELIEF VALVE, 2175 PSI
17	31593	4	VALVE SEAL KIT (FOR ONE SECTION)
17A		2	WIPER
17B		2	O-RING SMALL
17C		1	O-RING LARGE
17D		1	SHUTTLE DISC
17E		1	SPRING
18	TB1017L	4	LEVER KIT (FOR ONE SECTION)
18A		1	LEVER KNOB
18B		1	LEVER
18C		2	LEVER WASHER
18D		1	LEVER CLIP
18E		2	LINKAGE
18F		1	LEVER PIN
18G		1	ROLL PIN
18H		1	LEVER BOOT
18J		1	LEVER BOLT
18K		1	LEVER DUST COVER
18L		1	LEVER NUT
19	31603	4	COMPENSATOR
20	TB1017U	1	TIE ROD KIT
21	24214	1	O-RING, LARGE

COOLER ASSEMBLY

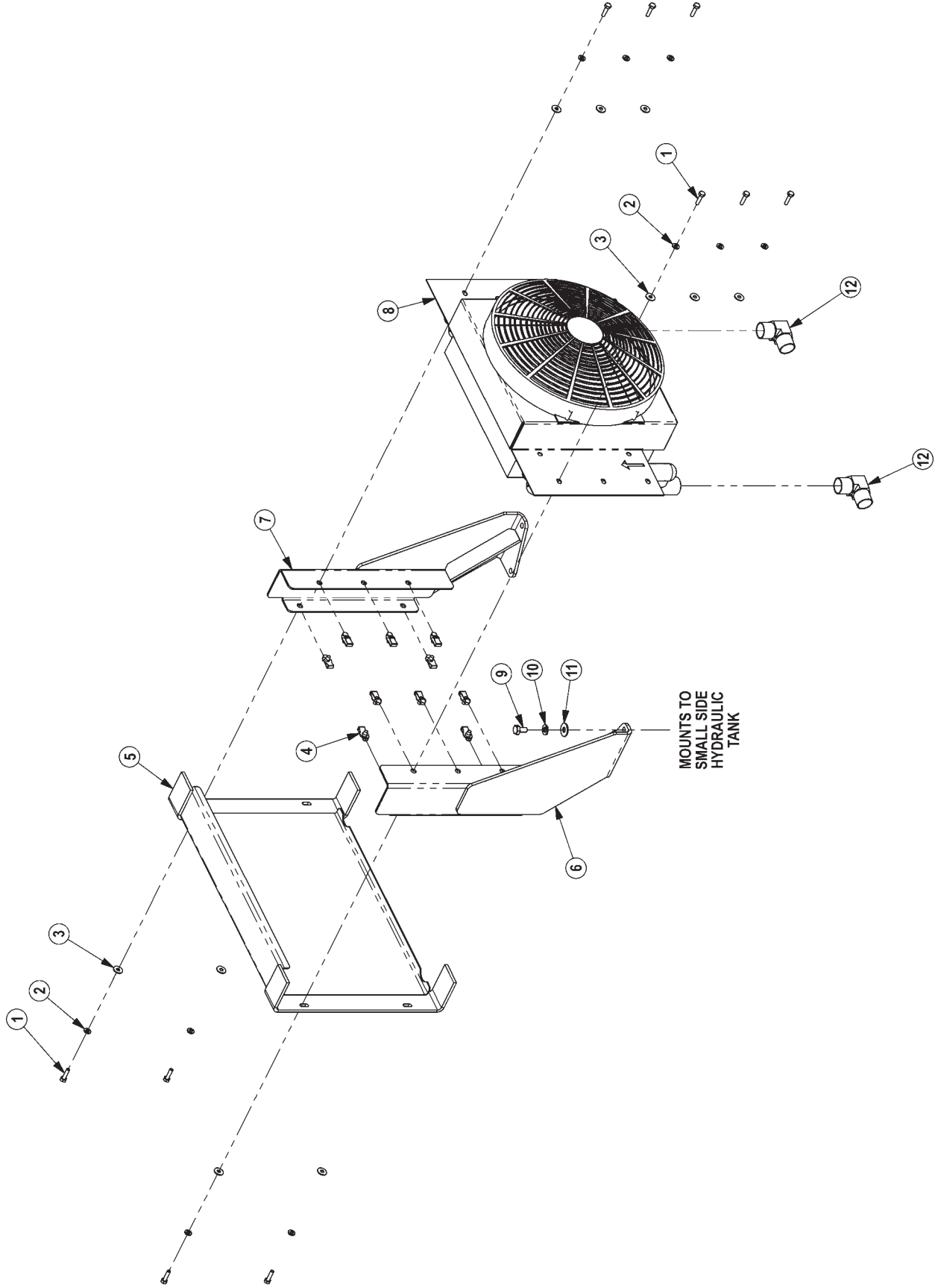

COOLER ASSEMBLY

ITEM	PART NO.	QTY.	DESCRIPTION
1	21530	10	CAPSCREW,1/4 X1 NC
2	21986	10	LOCKWASHER,1/4
3	22014	10	FLATWASHER,1/4
4	35176	10	1/4 U-NUT
5	06370015	1	SCREEN,COOLER,FRNT
6	06380006	1	MNT,COOLER,BUMPER TANK,RH
7	06380007	1	MNT,COOLER,BUMPER TANK,LH
8	06510026	1	COOLER,FRONT MNT
*	06510029	1	FAN ASSEMBLY
*	06510038	1	CABINET,SINGLE FAN
*	06510039	1	COOLING COIL,SINGLE FAN
9	21629	4	CAPSCREW,3/8 X 3/4 NC
10	21988	4	LOCKWASHER,3/8
11	22016	4	FLATWASHER,3/8
12	34117	2	ELBOW,1MOR X 1MJ90,FORGED

CASTER WHEEL REAR DECK

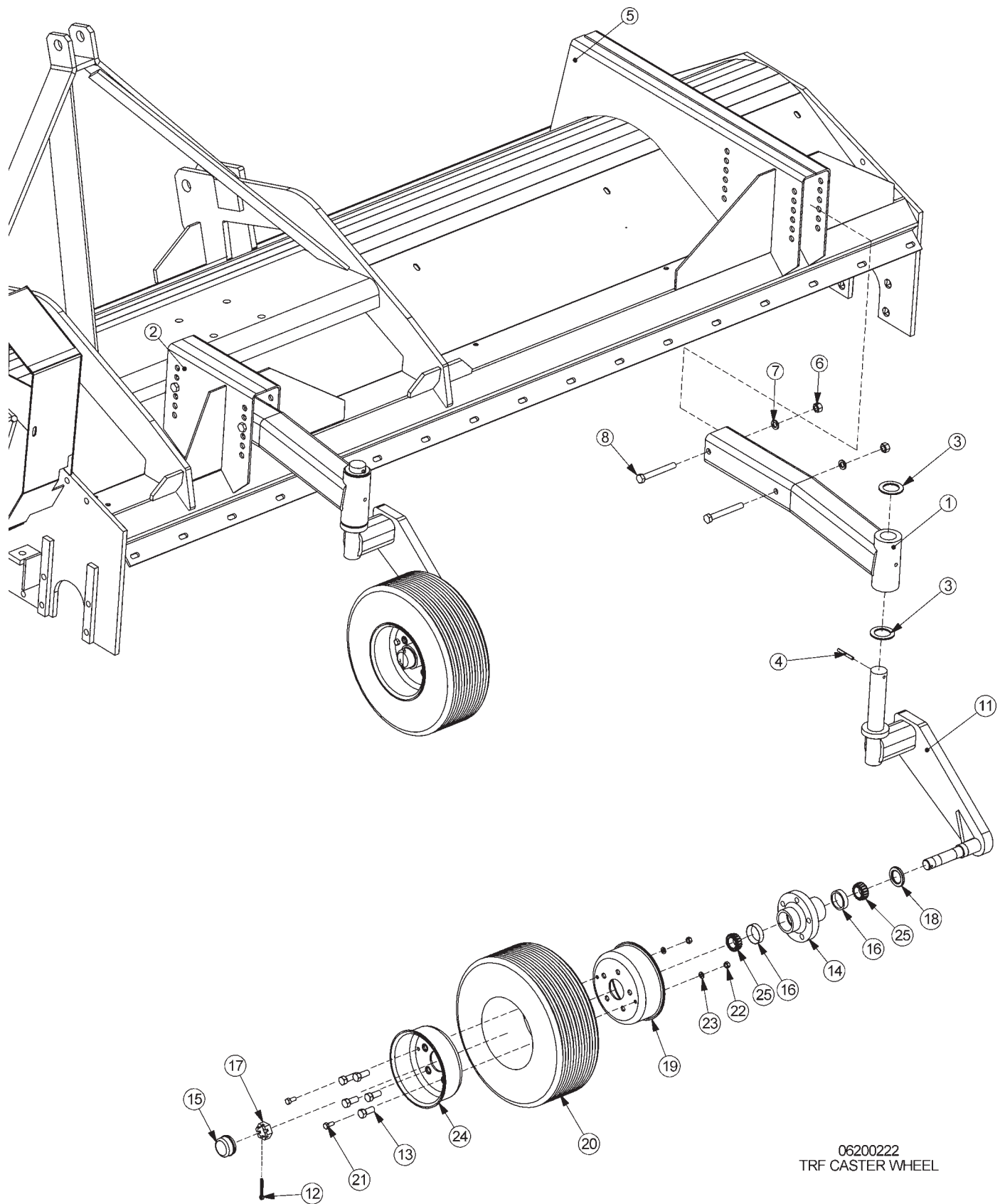

06200222
TRF CASTER WHEEL

CASTER WHEEL REAR DECK

ITEM	P/N	QTY	DESCRIPTION
1	TF3060	2	CASTER WHLARM,FLAIL
2	TF3052A	1	BRKT,REAR CASTER ADJ,LF
3	6T2617	4	BUSHING,MACH,1-1/2IDX 2-1/4OD
4	6T3014	2	ROLL PIN, 1/4" x 2"
5	TF3053	1	BRKT,REAR CASTER ADJ,RT
6	21725	4	HEX NUT, 1/2" NC
7	21990	4	LOCKWASHER, 1/2"
8	21741	4	CAPSCREW,1/2 x 5, NC
11	22057	2	SPINDLE, CASTER AXLE, ASSY
12	22533	2	COTTER PIN,3/16 X 2
13	22071	10	HUB STUD
14	22066	2	HUB,CASTER(REAR ROTARY)
15	22070	2	DUST CAP
16	6T0836	4	CUP,CASTER WHEEL
17	22073	2	HEX NUT,1NF(SLOTTED JAM NUT)
18	6T0838	2	SEAL
19	22696	2	RIM,REAR ROTARY CASTER
20	21416	2	TIRE,SOLID,RR-RTRY
21	21579	4	CAPSCREW,5/16 X 3/4 NC
22	21575	4	HEX NUT, 5/16,NC
23	21987	4	LOCKWASHER, 5/16"
24	22697	2	RIM,OUTER/RR RTRY CASTER ASSY
25	6t0830	4	BEARING,CONE,CASTER WHEEL

SIDE FLAIL TRAVEL LOCK

NOTE:
WITH THE BONNET IN THE TRANSPORT POSITION,
LOCATE THE PLACEMENT FOR ITEMS #3, & #4 AND
WELD ON AS NEEDED

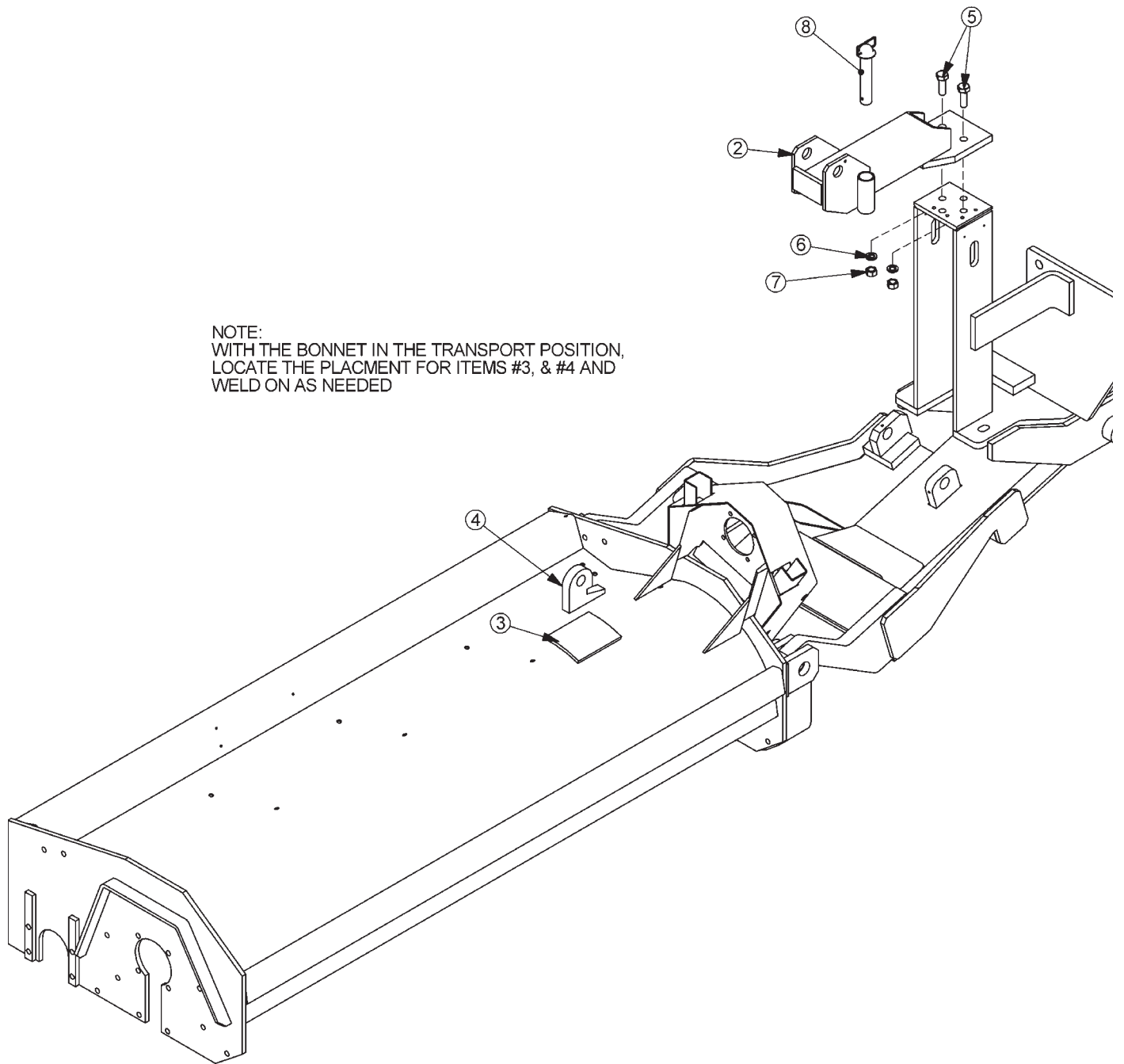

ITEM	PART NO.	QTY.	DESCRIPTION
*	REF	*	BONNET (REFER TO HEAD PARTS)
2	30531A	1	BRACKET, TRAVEL LOCK
3	TF4248	1	PLATE, TRAVEL LOCK
4	23745	1	TRAVEL LOCK HOOK
5	21783	2	CAPSCREW, 5/8"x2" NC
6	21992	2	LOCKWASHER, 5/8"
7	21775	2	HEX NUT, 5/8" NC
8	TF4250	1	PIN, TRAVEL LOCK

SOLENOID BRAKE VALVE ASSEMBLY

NOTE:

CAUTION - TORQUE COIL NUT TO 5 Ft. Lbs. MAXIMUM. DO NOT OVER TORQUE NUT, DAMAGE TO CARTRIDGE OR COIL WILL OCCUR.

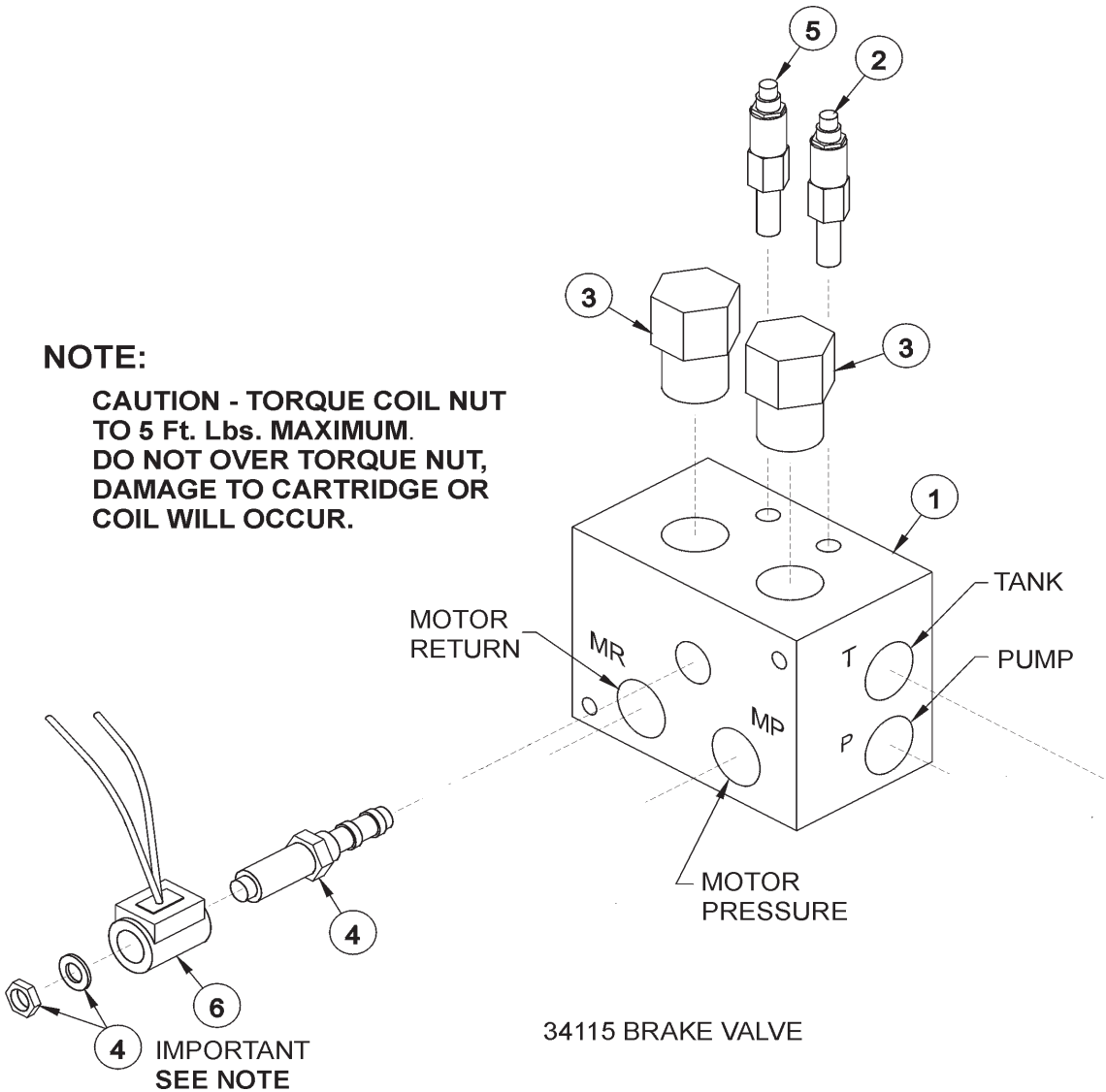

ITEM	P/N	QTY	DESCRIPTION
*	34115	AVAIL	SOLENOID BRAKE VALVE ASSEMBLY - HIGH PRESSURE
1	34092	1	BRAKE VALVE, BLANK
2	34095	1	RELIEF VALVE, 3000 PSI
3	34094	2	LOGIC ELEMENT
4	34093	1	CARTRIDGE, 2 POSITION, 3 WAY (WITH NUT & WASHER)
5	34091	1	RELIEF VALVE, 2600 PSI
6	34689	1	COIL, 12 VDC, BRAKE VALVE
**	34096	2	RELIEF SEAL KIT
**	34097	1	SOLENOID SEAL KIT
**	34098	2	ELEMENT SEAL KIT

BRAKE VALVE ASSEMBLY W/ METRI PAK

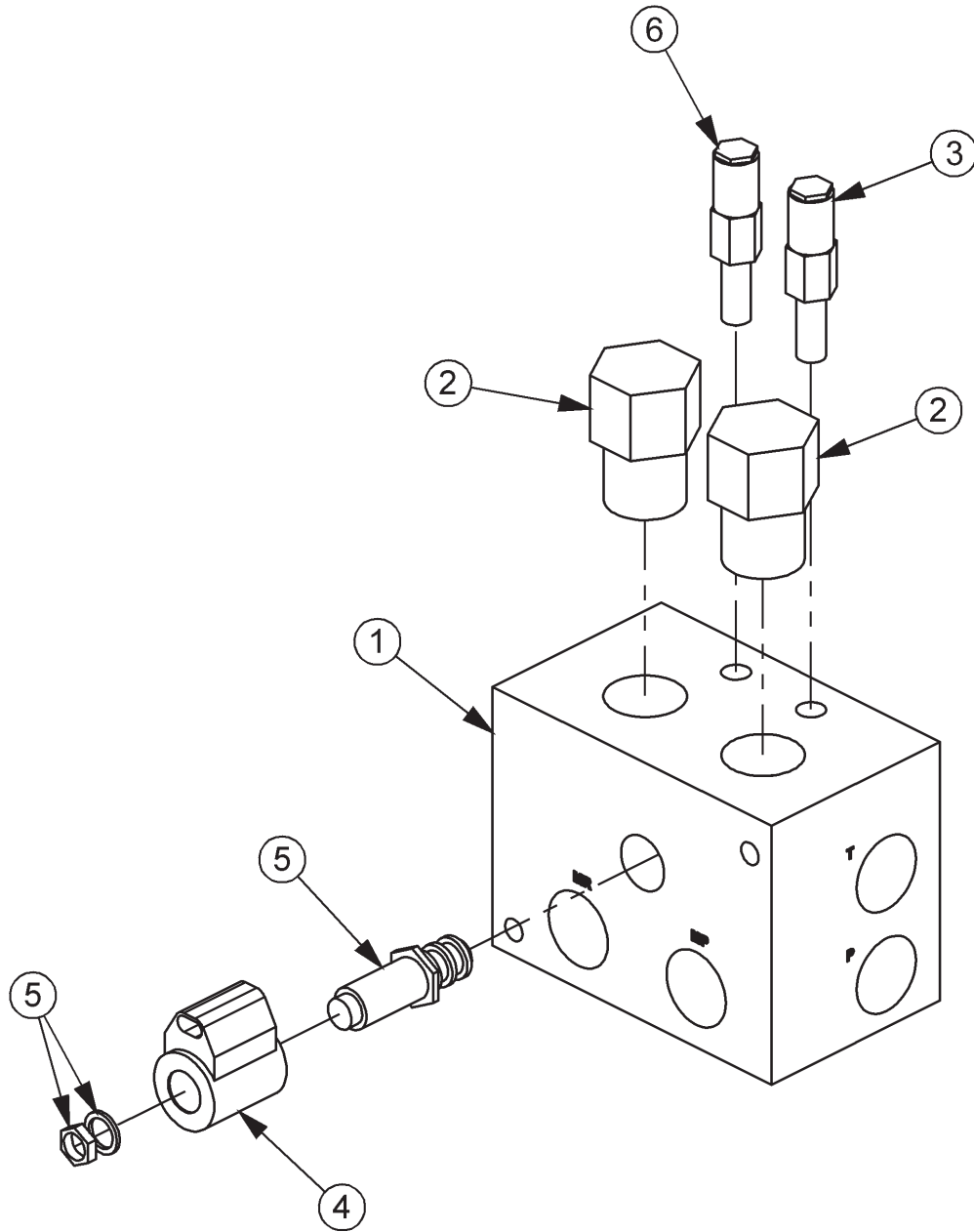

ITEM	PART NO.	QTY.	DESCRIPTION
1	34092	1	BRAKE VALVE, BLANK
2	34094	2	LOGIC ELEMENT
3	34095	1	RELIEF VALVE, 3000 PSI
4	06510095	1	METRI PAK COIL
5	34093	1	CARTRIDGE, 2 POSITION, 3 WAY (WITH NUT & WASHER)
6	34091	1	RELIEF VALVE, 2600 PSI

SOLENOID BRAKE VALVE HYDRAULIC SCHEMATIC

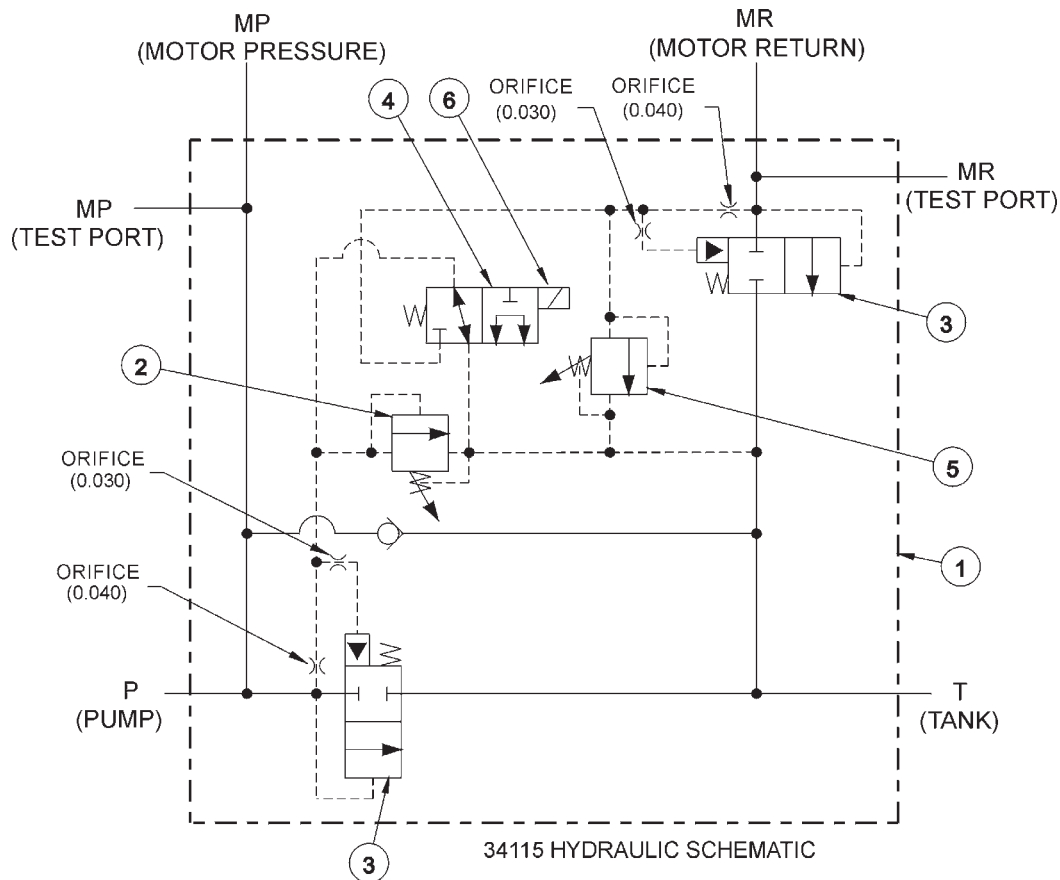

BRAKE VALVE TROUBLESHOOTING

FAILURE MODE:

- MOWER WILL NOT START - system pressure is low (engine not lugging).
- MOWER WILL NOT START - system pressure is high (engine lugging). "MR" port will be high pressure.
- MOWER WILL NOT ROTATE AT FULL SPEED - limited power.
- MOWER BLADE WILL NOT STOP - blade will not stop in proper time.

CHECK STEPS

- 1 thru 6
- 7
- 3 thru 5
- 7 thru 9

CORRECTIVE STEPS:

1. Check for voltage at solenoid (item 6), voltage must be between 10.2 volts and 13.8 volts.
2. Remove, inspect solenoid and cartridge (items 4, 6) for wear or contamination.
3. Remove, inspect logic elements near "P" port (item 3) for wear or contamination.
4. Remove, inspect 3000 psi relief valve (item 2) for wear or contamination.
5. Remove and inspect orifices near "P" port for contamination.
6. Remove "P" port hose and fitting, visually inspect for contamination, check ball for movement.
7. Remove and inspect orifices near "MR" port for contamination.
8. Remove, inspect 2600 psi relief valve (item 5) for wear of contamination.
9. Remove, inspect logic element near "MR" port (item 3) for wear or contamination.

DECAL LOCATION

DECALS FLAIL LOCATIONS

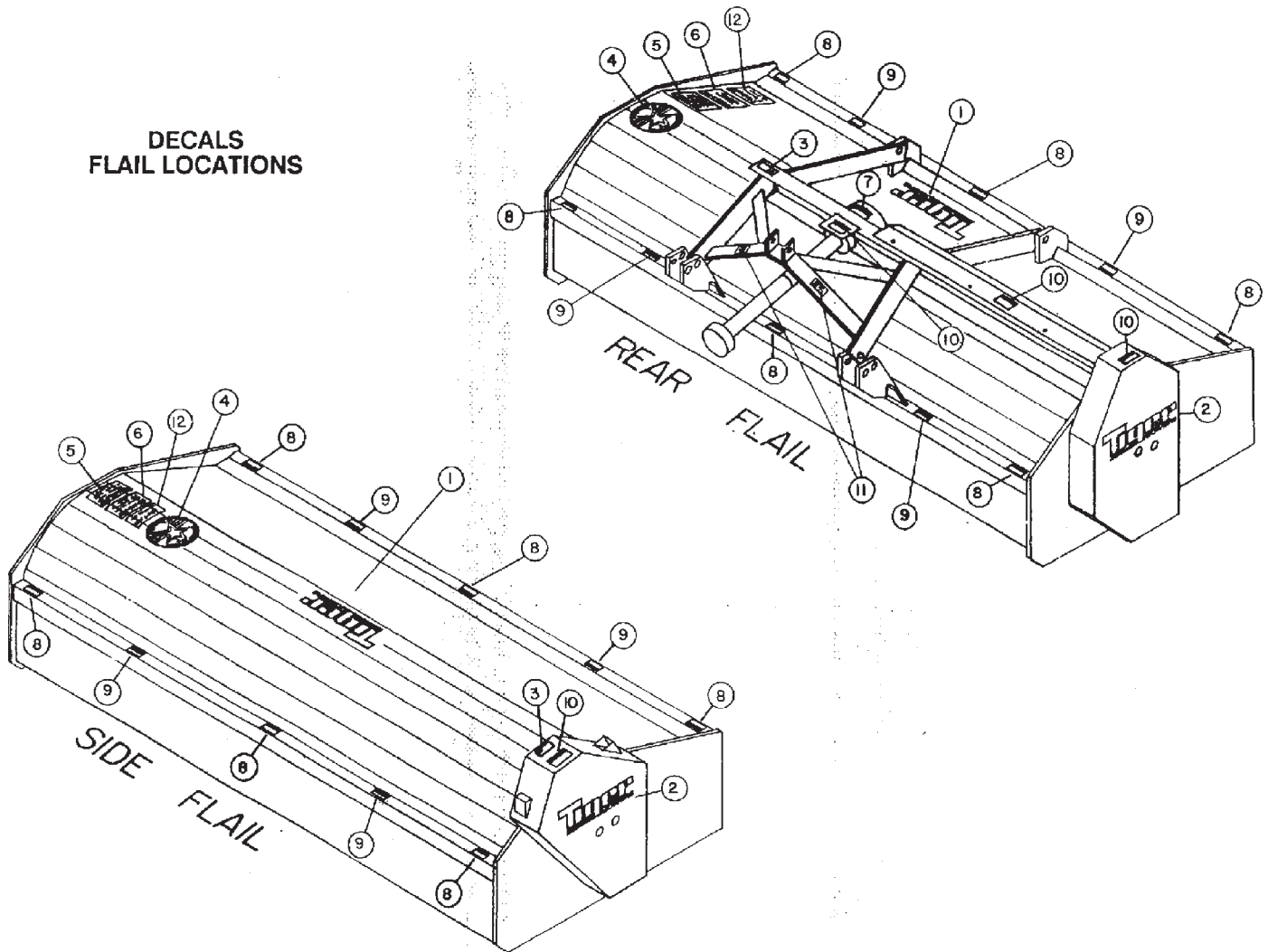

PB80068

ITEM	PART NO.	QTY.	DESCRIPTION
1	31522	6	DECAL, TIGER LOGO, 10" X 5.5"
2	22839	3	USE HAND GREASE GUN
3	N/A	3	SERIAL NUMBER PLATE
4	6T3236	3	MADE IN U.S.A.
5	6T3249A	3	LUBE CUTTER SHAFT BEARING
6	6T3261	3	LUBE GROUND ROLLER BEARING
7	6T3240	1	USE SYNTHETIC GEAR LUBE
8	6T3217	18	KEEP HANDS AND FEET CLEAR
9	6T3224	12	DANGER DISCHARGE OPENING
10	TB1011	5	DO NOT REMOVE
11	TF1112	2	KEEP LIFT ARMS IN SLOTS

SWITCHBOX SERVICE PARTS

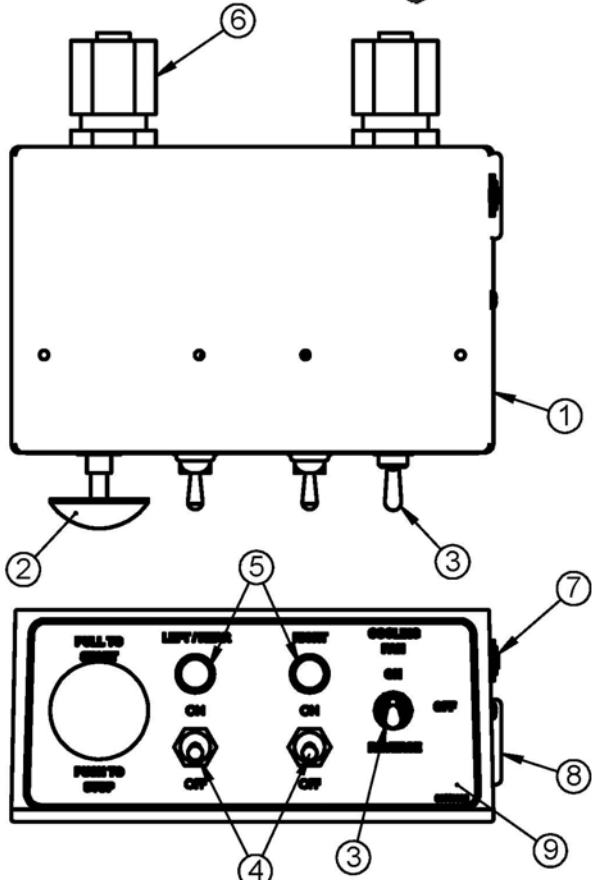

ITEM	P/N	QTY.	DESCRIPTION
1	06514011	1	SWBX,ALUM,BLK,06510097
2	35226	1	SWITCH,MOWER,COLEHERSEE
3	06510028	1	SWITCH,FORWARD/BRAKE/REV
4	33811	2	SWITCH,MASTER/DECK FLOAT
5	6T3923	2	INDICTATOR LIGHT,ON,RED
6	34540	2	STRAIN RELIEF,3/4,BLACK,NYLON
7	06514006	1	BREAKER,15A,SWBX
8	06514015	1	ALARM,SWBX,REVERSER
9	06550002	1	DECAL,SWTCHBX,TWIN/T3F,REV FAN
10	35227	1	RELAY,DP,DT,12V,LY2F,35226

SWITCHBOX SCHEMATIC

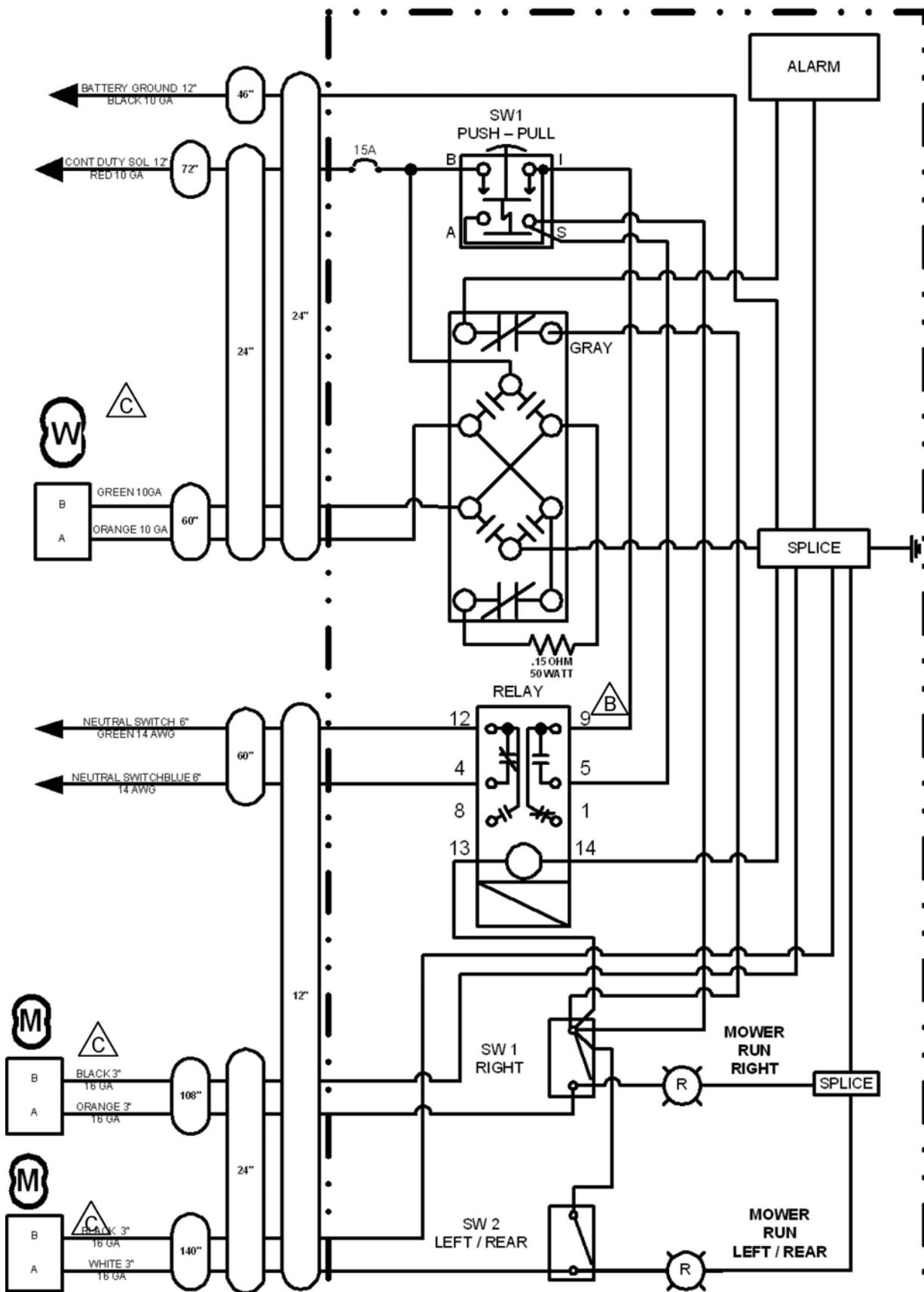

PTO STAND

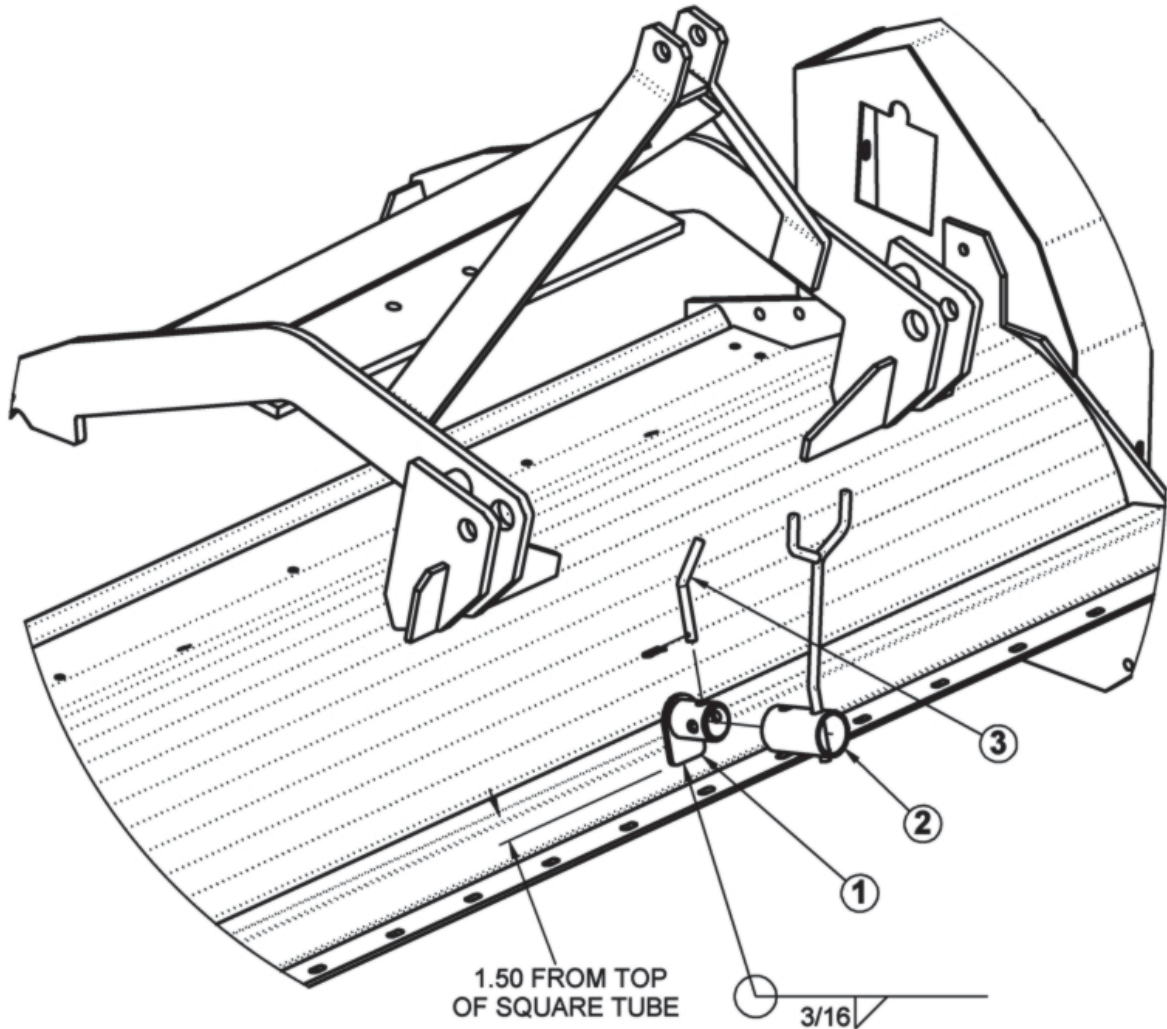

NOTES:

1. LOCATE ITEM 1 ON TUBE AS SHOWN, CENTER ON GEAR BOX SHAFT.
2. WELD ITEM 1 AS SHOWN AFTER LOCATING
3. AFTER WELDING, PIN ITEM 2 IN PLACE WITH ITEM 3.

ITEM	PART NO.	QTY.	DESCRIPTION
1	06370080	1	BRACKET,SUPPORT
2	06370022	1	SUPPORT, PTO
3	06520048	1	PIN, .5x2.5,BENT,W/R-CLIP

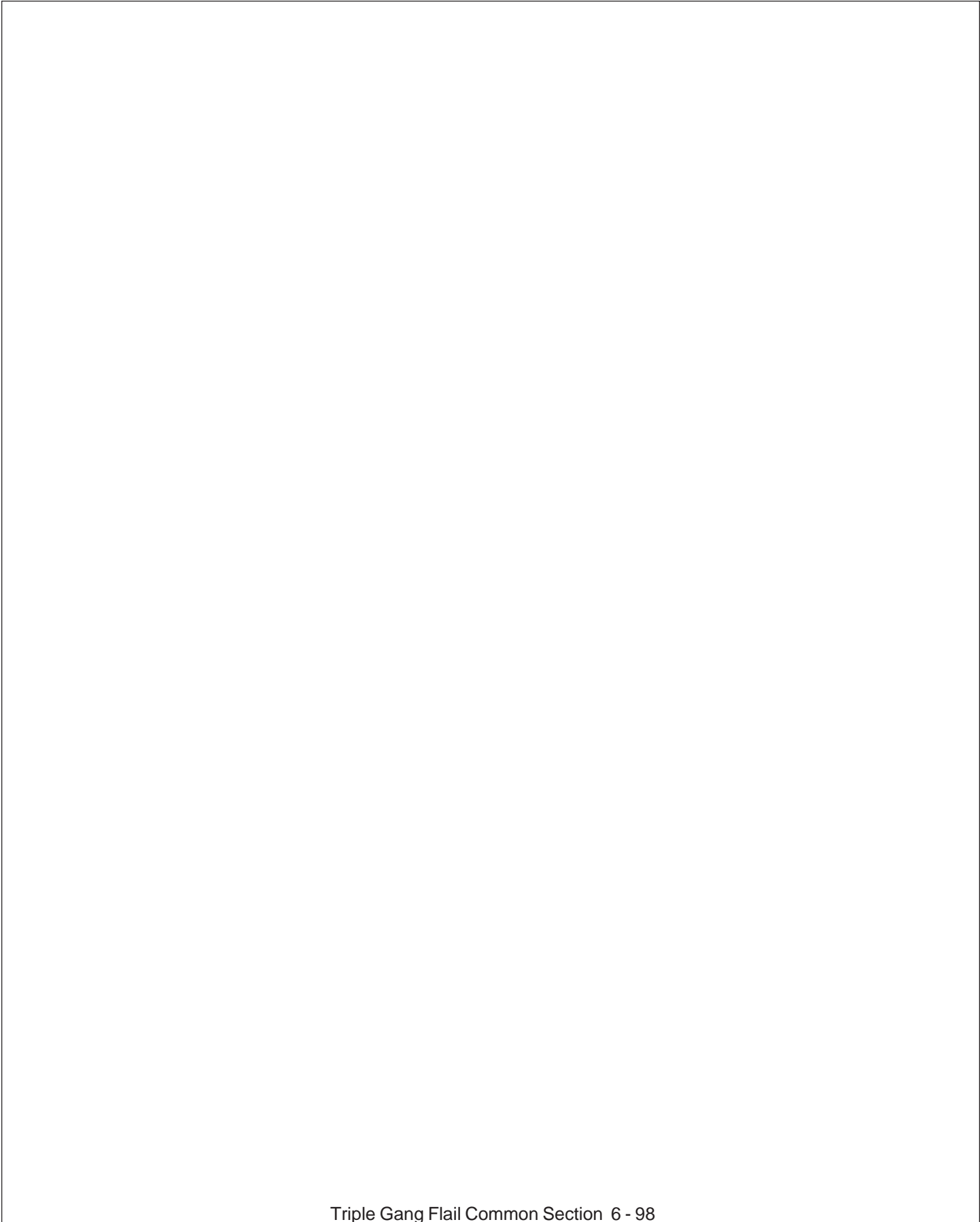
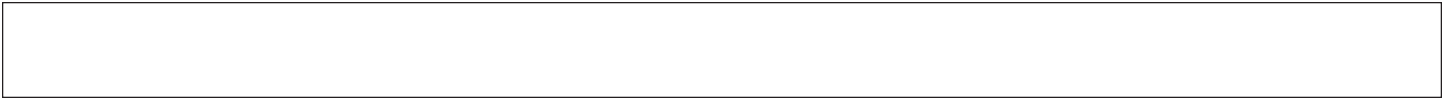

JD 52-5525 TRIPLE EGRESS

TRIPLE EGRESS SECTION

ASSEMBLY - TRIPLE EGRESS, CAB

TRIPLE EGRESS MOUNTING

Park the tractor on a flat, hard, level surface. Lower both side decks down onto the hard surface. Make sure the engine is off and the park brake has been set. Operate the lift controls several times to release any pressure contained in the hydraulic lift system. Disconnect the positive battery cable from the battery. Then remove the right rear wheel from the tractor. Next remove the left side deck lift hoses from the lift valve and both lift cylinders, mark or label valve ports and cylinders as hoses are removed.

Install the egress switch box brackets on the left side of the mower pump mounting bracket, using hardware supplied. See pictures on next page. After the bracket is secured, then remove the front cover from the switch box, and install the switch box back half to the switch box bracket with (4) 8/32 x 1/2" machine screws. Reinstall the front cover onto the switch box.

Install the egress pump mounting bracket onto the right side of the tractor located under the cab in front of the right rear axle using hardware provided. Next preassemble the rear half of the pump cover onto the egress pump with the hardware provided, do not tighten bolt at this time. Connect the hoses for the C1 port to the egress pump port only. Do not tighten hoses at this time. The pump is now ready to be mounted to the pump mounting bracket. Secure egress pump to the bracket with the hardware provided.

Locate the ports on the egress pump labeled "A1", "A2", "B1", "B2", "C1" and "C2", these ports will be the connection points for the hydraulic lift lines.

A1 port - to lift valve -- left hand outboard cylinder gland

A2 port - to cylinder -- left hand outboard cylinder gland

B1 port - to lift valve -- left hand outboard cylinder butt

B2 port - to cylinder -- left hand outboard cylinder butt

C1 port - to lift valve -- left hand inboard cylinder gland

C2 port - to cylinder -- left hand inboard cylinder gland

Route the hoses to the lift valve and or cylinder as specified above, tighten all hose fittings. Refer to the Parts section for the location of hose connections on the lift valve.

Now that the hydraulic lines are installed, connect the power cable from the positive post of the egress pump solenoid to the tractor starter solenoid positive post. Also connect the ground cable from the negative post on the egress pump electric motor to a bracket mounting bolt on the frame. Then route the cable from the switch box along the tractor to the egress pump and connect the male to the female plug. Secure cable with cable tie.

Next remove the drain plug on the bottom of the tractors transmission, **CAUTION** hydraulic oil will come out and maybe hot. Oil loss can be reduced by attaching a shop vacuum to the tractor transmission fill neck. Install fittings into the transmission drain hole, refer to part section for parts and illustrations. Connect the suction hose from the filter to the fittings on the tractor transmission, cut the hose to the required length. Install a hose clamp both end of the hose.

Install the front half of the cover onto the egress pump with provided hardware. Make sure all mounting hardware and hose connections are tight. Check hydraulic oil level and add if required. Reinstall the right rear wheel and reconnect the positive battery cable to the battery.

ASSEMBLY - TRIPLE EGRESS, CAB

TRIPLE EGRESS MOUNTING CONTINUED

NOTE: Use the egress pump **ONLY** to lifting or lowering the head for storage, or transportation by trailer. When the egress pump is not in use make sure the switch box key is in the "off" position and key has been removed.

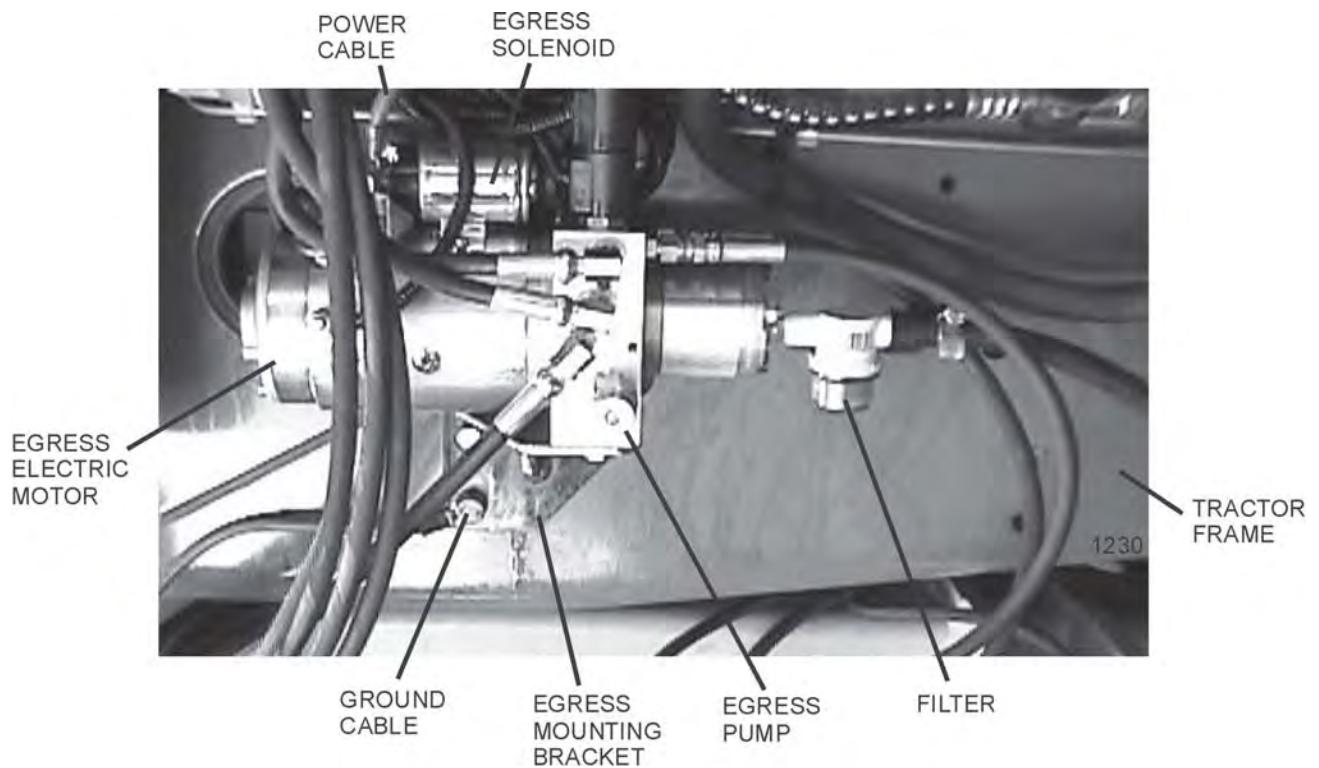
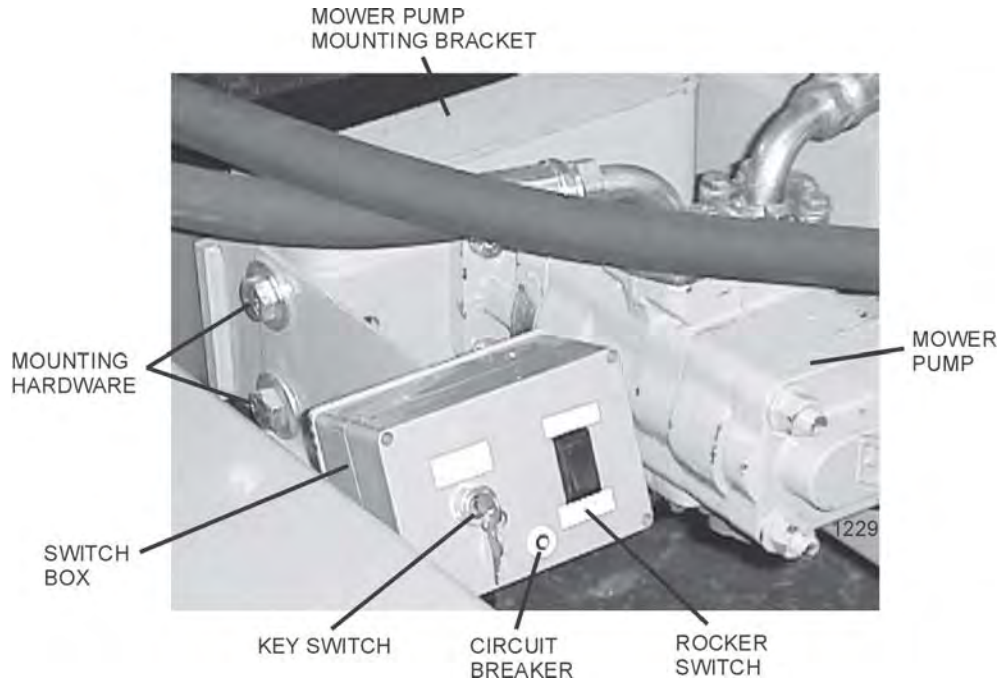

OPERATION - TRIPLE EGRESS, CAB

EGRESS OPERATION

When operating the egress system to lift the deck, turn the key to the "DRAFT" position and push the rocker switch to the "LIFT" position and it will lift the draft beam. Once the draft beam is lifted to the highest position, then turn the key to the "DECK" position and push the rocker switch to the "LIFT" position, and that will raise the deck up to the travel lock. To seat the deck into the travel lock turn the key back to the "DRAFT" position and push the rocker switch to the "LOWER" position, until the deck is fully seated into the travel lock. Turn the key to the "OFF" position and remove the key. To lower the deck in sert key and reverse the steps that were done to raise the deck.

WARNING!



CAUTION: Never leave the key in the egress switch box. Field conditions can shake the key out of the switch box and become lost. Also personal injury or death can occur from sudden dropping or inadvertent operation of the controls. Make certain the area is clear before lowering or raising the deck.

TRIPLE EGRESS HYDRAULIC DIAGRAM

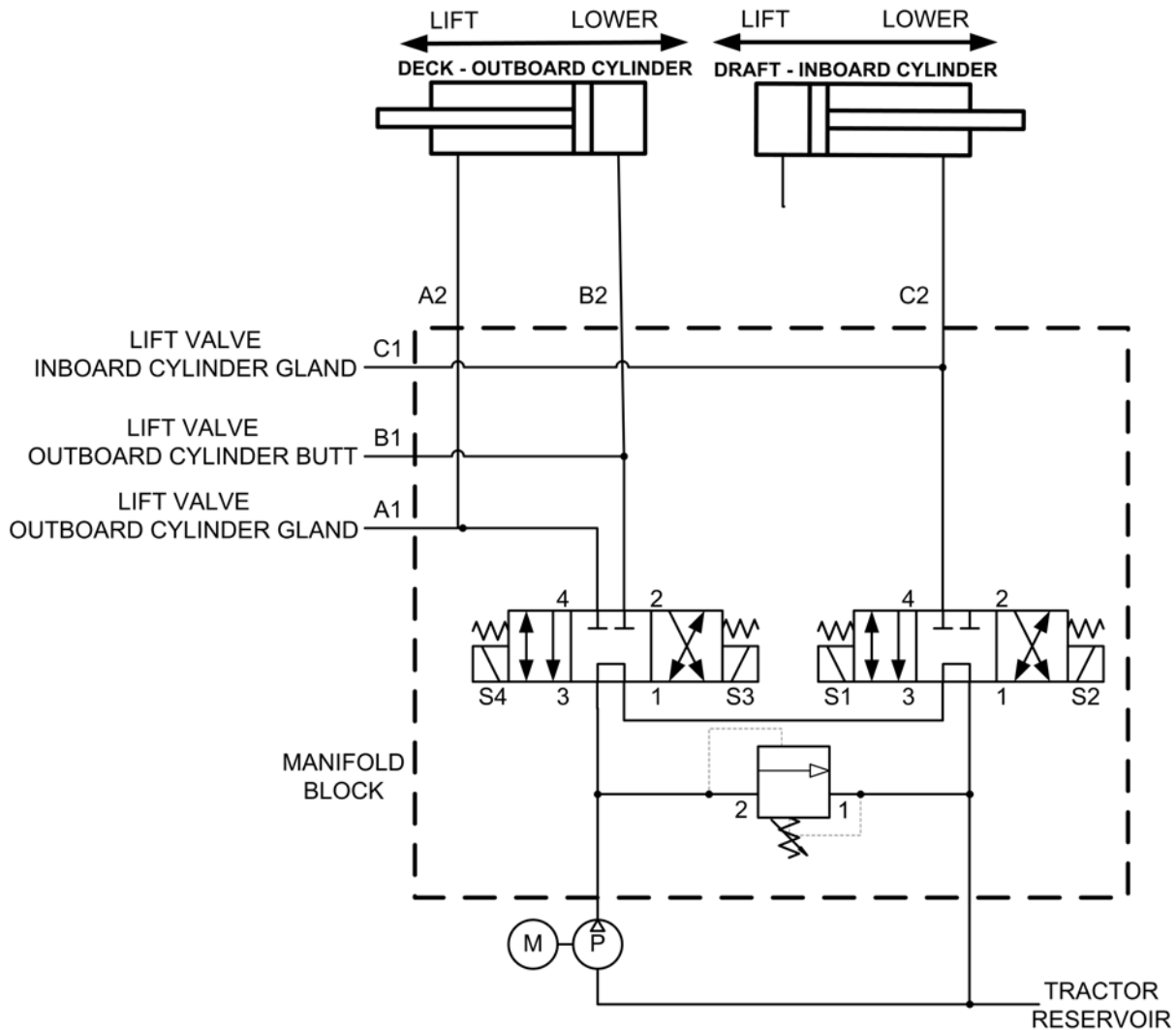

TRIPLE EGRESS TROUBLESHOOTING

FAILURE MODE:

- DECK OR DRAFT CYLINDER ONLY GOES ONE WAY.
- DECK OR DRAFT CYLINDER WILL NOT STAY IN POSITION.
- WILL OPERATE WITH LIFT VALVE, BUT NOT WITH EGRESS.
- EGRESS DOES NOT OPERATE AS FAST AS IT USED TO.

CHECK STEPS

- 1 and 2
- 1 and 2
- 3 and 5
- 3 and 4

CORRECTIVE STEPS:

1. Remove relief valve installed on tractor lift valve. Visually inspect for contamination.
2. Remove solenoid valve (S1, S2, S3, S4) from egress unit and verify spool shift.
3. Remove relief valve from egress unit and visually inspect for contamination.
4. Inspect suction strainer for contamination.
- 5a. Verify supply voltage at pump motor posts on egress.
- 5b. Verify voltage at pump motor relay while switches are activated.
- 5c. Verify voltage at solenoid valve (S1, S2, S3, S4) on egress unit.
- 5d. Check or reset circuit breaker.

NOTE:

1. All voltage readings must be between 10.2 volts and 13.8 volts.

PUMP MOUNTING - TRIPLE EGRESS, CAB

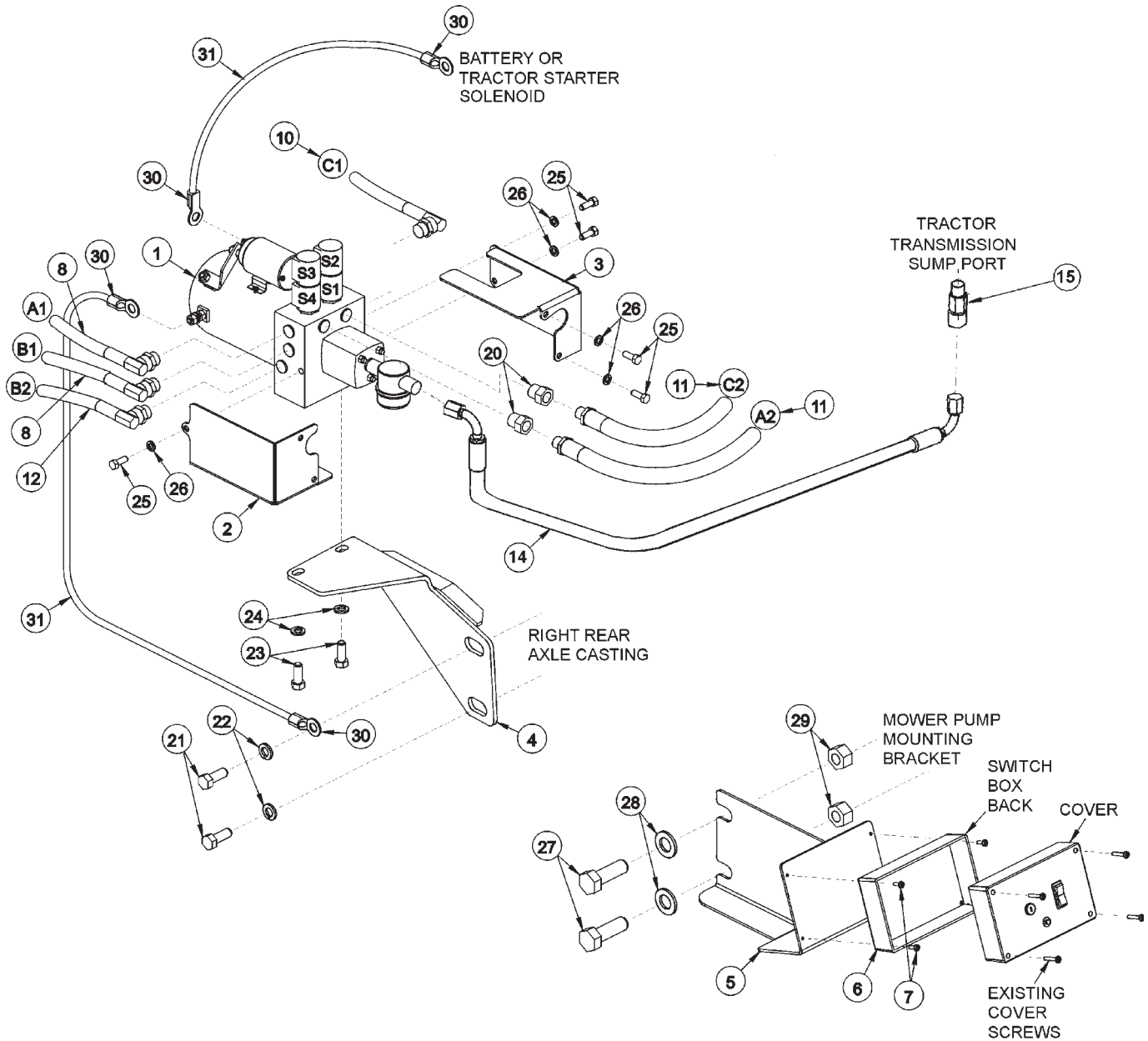

HOSE ROUTING

- A1 PORT - TO LIFT VALVE -- LEFT HAND OUTBOARD CYLINDER GLAND
- A2 PORT - TO CYLINDER -- LEFT HAND OUTBOARD CYLINDER GLAND
- B1 PORT - TO LIFT VALVE -- LEFT HAND OUTBOARD CYLINDER BUTT
- B2 PORT - TO CYLINDER -- LEFT HAND OUTBOARD CYLINDER BUTT
- C1 PORT - TO LIFT VALVE -- LEFT HAND INBOARD CYLINDER GLAND
- C2 PORT - TO CYLINDER -- LEFT HAND INBOARD CYLINDER GLAND

PUMP MOUNTING - TRIPLE EGRESS, CAB

ITEM	PART NO.	QTY.	DESCRIPTION
1	06510066	1	EGRESS PUMP
2	34306	1	COVER FRONT HALF
3	34307	1	COVER REAR HALF
4	34361	1	MOUNTING BRACKET EGRESS
5	34124	1	MOUNTING BRACKET SWITCH BOX
6	34123	1	SWITCHBOX
7	6T3951	4	SCREW MACHINE 8-32UNC X 1/2"
8	34437	2	HOSE 1/4" x 64" 1/2ORB90 x 3/8ORB90
10	34440	1	HOSE 1/4" x 64" 1/2ORB90 x
11	34439	2	HOSE 1/4" x 64" 3/8ORB90 x 3/8FJ
12	34438	1	HOSE 1/4" x 82" 3/8ORB90 x 3/8MJ
14	06500379	1	HOSE
15	06503103	1	ADAPTER
20	32901	2	ADAPTER
21	24860	2	CAPSCREW 20MM x 40MM
22	24881	2	LOCKWASHER 20MM
23	21629	2	CAPSCREW 3/8" X 3/4"
24	21988	2	LOCKWASHER 3/8"
25	21529	5	CAPSCREW 1/4" X 3/4"
26	21986	5	LOCKWASHER 1/4"
27	21833	2	CAPSCREW 3/4" X 2 3/4"
28	22021	2	FLATWASHER 3/4"
29	21825	2	HEX NUT 3/4"
30	23572	4	RING CONNECTOR 3/8" STUD
31	24201	12'	WIRE RED #6 GA

PUMP PARTS - TRIPLE EGRESS, CAB

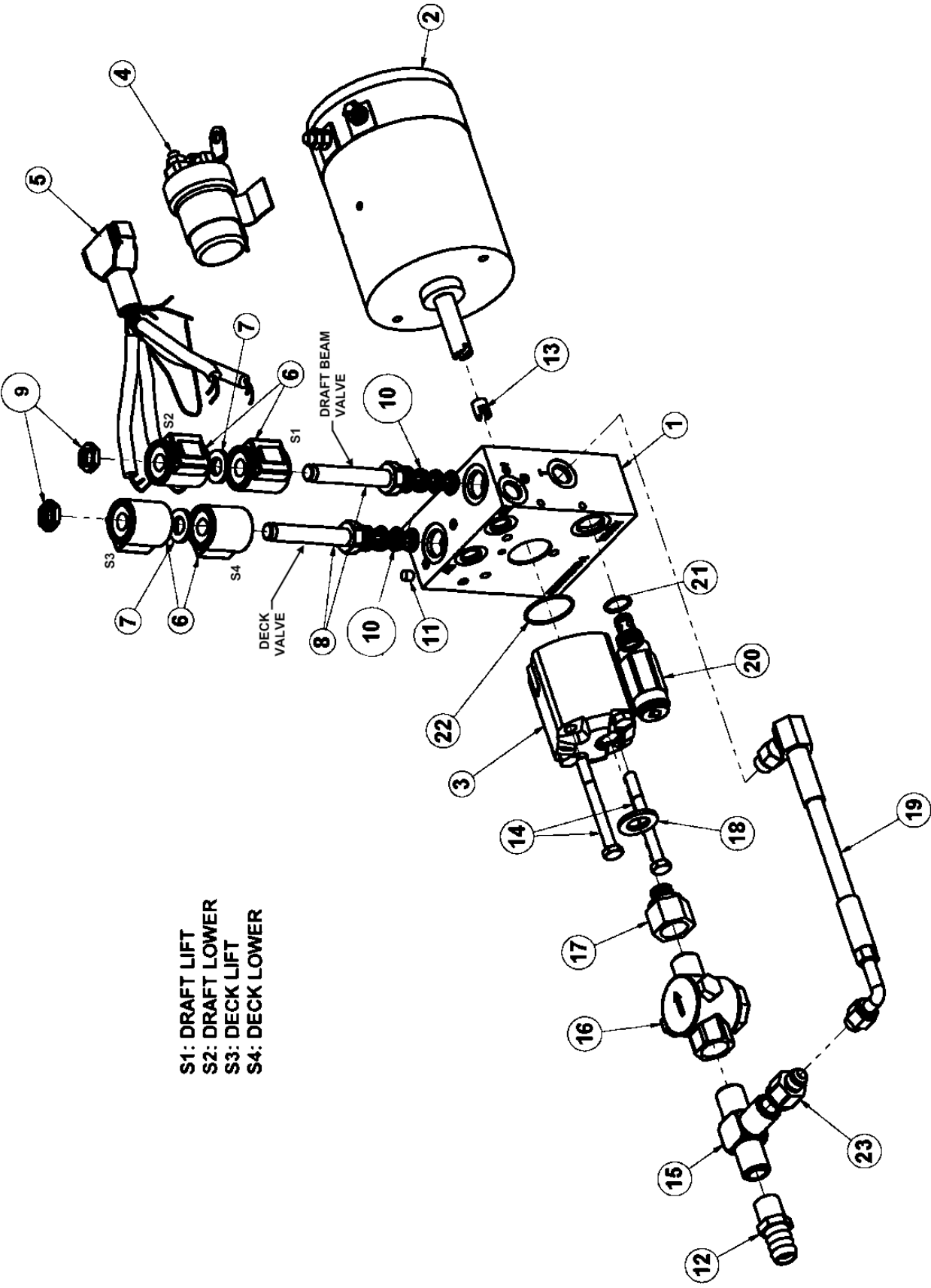

- S1: DRAFT LIFT
- S2: DRAFT LOWER
- S3: DECK LIFT
- S4: DECK LOWER

PUMP PARTS - TRIPLE EGRESS, CAB

ITEM	P/N	QTY	DESCRIPTION
1	06510067	1	MANIFOLD,EGRESS,HYTOST,T3F
2	06510068	1	MOTOR,EGRESS,HYTOS,T3F
3	06510070	1	PUMP,EGRESS,HYTOS,T3F
4	06510170	1	RELAY,06510066
5	06510171	1	HARNESS,06510066
6	06510172	4	COIL,06510066
7	06510173	2	SPACER,06510066
8	06510174	2	SPOOL,06510066
9	06510175	2	NUT,06510174
10	06510176	6	SEALKIT,06510174
11	06510177	1	PLUG,06510066
12	06510179	1	ADAPTER,BARBx1/2NPT,06510066
13	06510180	1	COUPLING,06510066
14	06510181	2	BOLT,06510070
15	06510182	1	TEE,06510066
16	06510183	1	FILTER,06510066
17	06510184	1	ADAPTER,06510066
18	06510185	1	WASHER,06510066
19	06510186	1	HOSE,06510066
20	06510187	1	RELIEF,06510066
21	06510188	1	SEAL,06510187
22	06510189	1	SEALKIT,06510066
-	06510178	1	O-RING,06510066
23	33380.	1	ADAPTER,3/8MORBx1/2FOR

SWITCH BOX PARTS - TRIPLE EGRESS, CAB

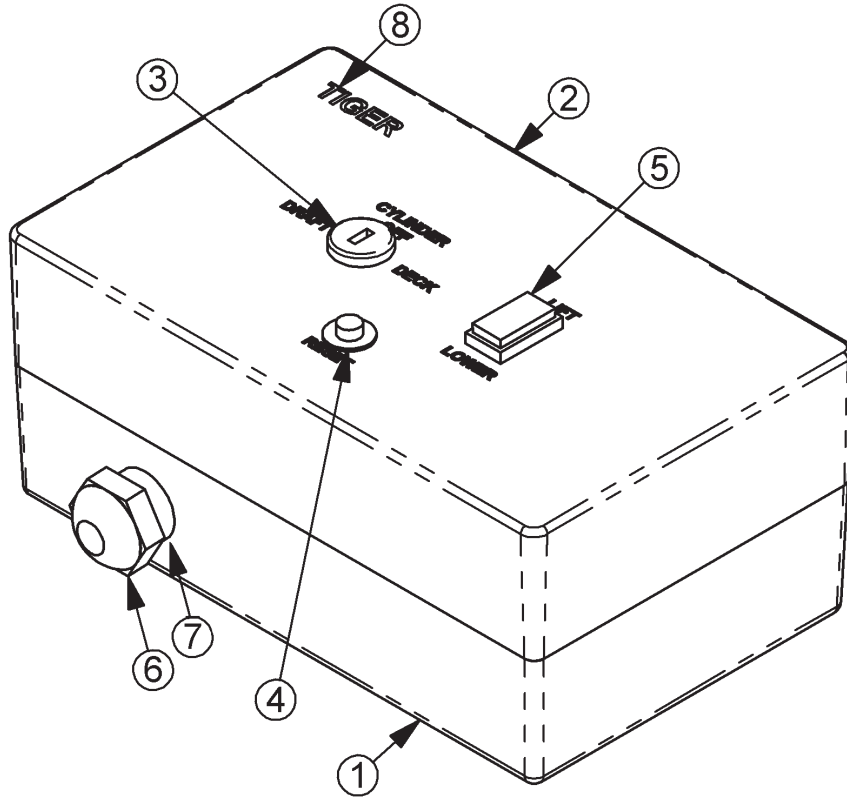

34123, SWITCH BOX ASSY, EGRESS T3F

ITEM	P/N	QTY	DESCRIPTION
1	34934	1	BOTTOM BOX, EGRESSES SWITCH BOX
2	34933	1	TOP BOX, EGRESSES SWITCHBOX
3	34937	1	KEY SWITCH, EGRESSES SWITCH BOX
4	34936	1	10 AMP CKT BRKR, EGRESSES SWITCH BOX
5	34935	1	ROCKER SWITCH, EGRESSES SWITCH BOX
6	34938	1	STRAIN RELIEF, EGRESSES SWITCH BOX
7	34939	1	3/4 LOCK NUT, EGRESSES SWITCH BOX
8	34940	1	DECAL, TIGER

TRIPLE EGRESS SCHEMATIC

TRIPLE EGRESS SCHEMATIC

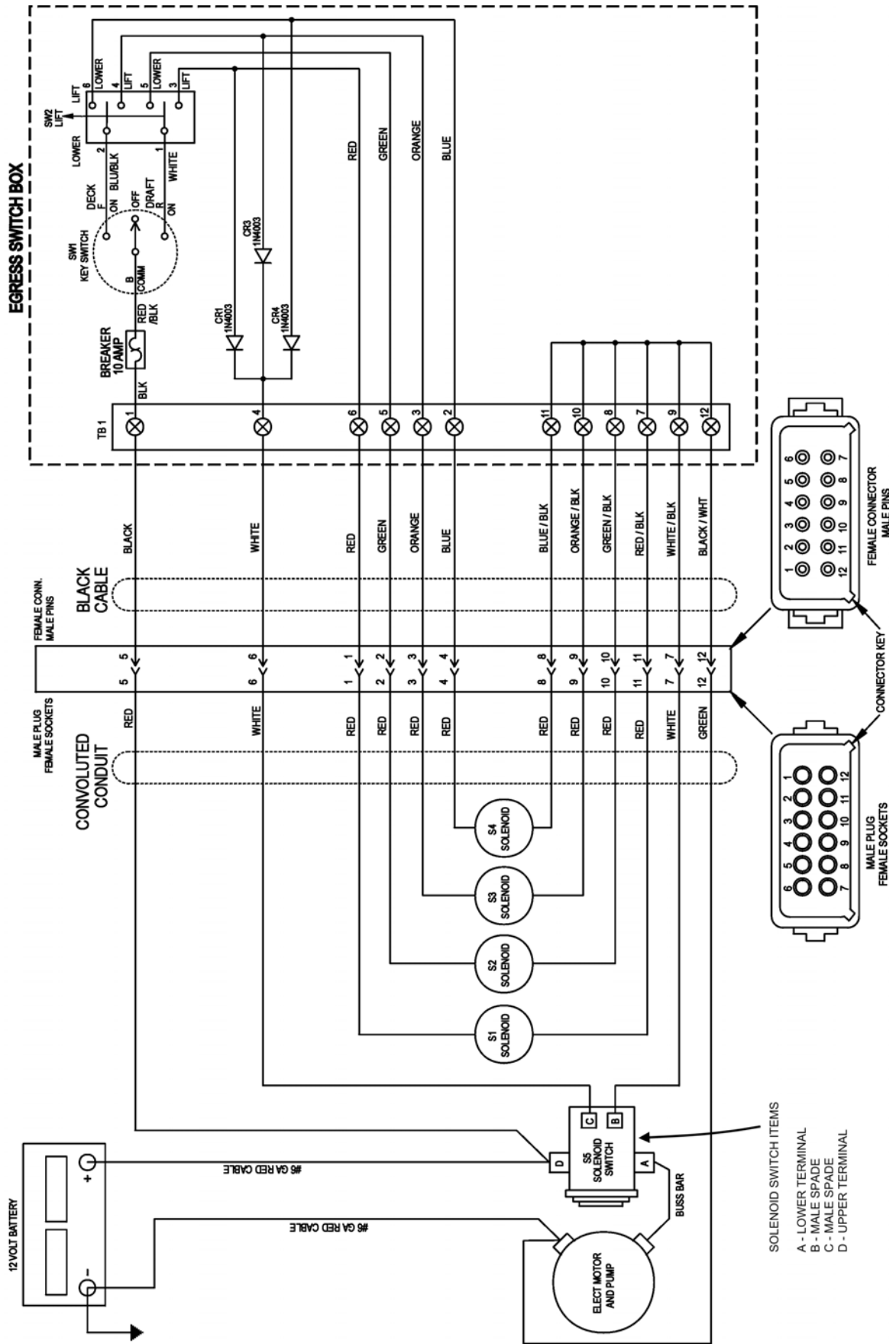

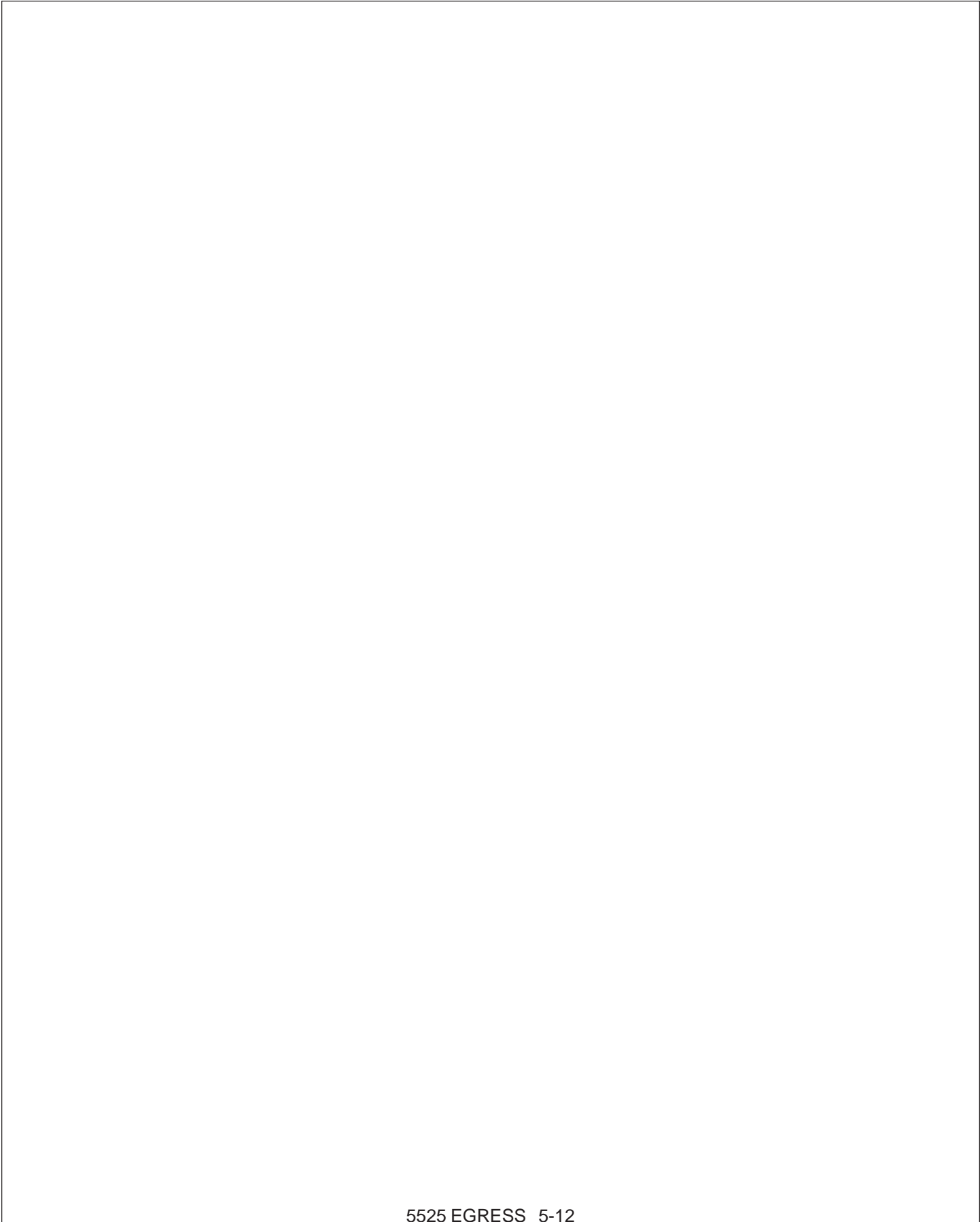

WARRANTY SECTION

WARRANTY INFORMATION

Tiger Corporation, 3301 N. Louise, Sioux Falls, South Dakota, warrants to the original Retail Customer, the new Tiger equipment is free of defects in material and workmanship. Any part of equipment that in Tiger's judgement, show evidence of such defects will be repaired or replaced without charge, provided that the failure of part(s) shall have occurred within twelve (12) months from the date of delivery of said equipment to the Retail Customer. Expendable components such as knives, oil, chain sprockets, skid shoes, knife mounting disks and the like are excluded but not limited to this warranty.

The Retail Customer must pay the transportation cost to and from the Tiger Dealer's service shop for warranty service. Warranty service will be performed by the Tiger Dealer from whom the equipment was purchased, during service shop regularly scheduled days and hours of operation.

All Tiger obligation under this warranty shall be terminated if the equipment is modified or altered in ways not approved in writing by Tiger, if repair parts other than genuine Tiger repair parts have been used, or if the equipment has been subject to misuse, neglect, accident, improper maintenance or improper operation.

Tiger Corporation reserves the right to make improvements in design or changes in specification at any time without incurring any obligation to owners of equipment previously sold.

No agent or person has authority to alter, add to or waive the above warranties which are agreed to be in the only warranties, representations or promises, expressed or implied, as to the quality or performance of the products covered and which do not include any implied warranty of merchantability or fitness. In no event will Tiger be liable for incidental or consequential damages or injuries, including, but not limited to, loss of profits, rental or substitute equipment or other commercial loss.

**THERE ARE NO WARRANTIES WHICH EXTEND
BEYOND THOSE EXPRESSED HEREIN.**

It is the Purchasers obligation to sign the warranty registration form **AFTER** he / she has Read and Understands the Operation and Safety Instructions stated within this manual.

ONE LAST WORD

This manual cannot possibly cover all of the potentially hazardous situations you will encounter. By being familiar with the safety rules, operating and maintenance instructions in this manual you can help prevent accidents. The objective of this manual is to help make you a better operator. Remember, **SAFETY IS YOU!**



1012

Your safety and the safety of those around you depends on **YOU**. Common sense should play a large role in the operation of this machine.

Since we at Tiger Corporation are constantly striving to improve our products, we reserve the right to change specifications or design at any time.

TO THE OWNER / OPERATOR / DEALER



To keep your implement running efficiently and safely, read your manual thoroughly and follow these directions and the Safety Messages in this manual and on the machine. The table of contents clearly identifies each section where you can easily find the information you need.

The Occupational Safety and Health Act (OSHA 1928.51 subpart C) makes the following minimum requirements for tractor operators.

OWNER REQUIREMENTS:

1. Provide a Roll-Over-Protective Structure that meets the requirements of this Standard; and
2. Provide Seatbelts that meet the requirements of this Standard and SAE J3C; and
3. Ensure that each employee uses such Seatbelt while the tractor is moving; and
4. Ensure that each employee tightens the Seatbelt sufficiently to confine the employee to the protected area provided by the ROPS.

OPERATOR REQUIREMENTS:

1. Securely fasten seatbelt if the tractor has a ROPS.
2. Where possible, avoid operating the tractor near steep ditches, embankments, and holes.
3. Reduce speed when turning, crossing slopes, and on rough, slick, or muddy surfaces.
4. Stay off slopes too steep for safe operation.
5. Watch where you are going – especially at row ends, on roads, and around trees.
6. Do Not permit others to ride.
7. Operate the tractor smoothly – no jerky turns, starts, or stops.
8. Hitch only to the draw-bar and hitch points recommended by the tractor manufacturer.
9. When the tractor is stopped, set brakes securely and use park lock, if available



Printed in USA
© Tiger Corporation