



BENGAL BRUTE ASSEMBLIES

JOHN DEERE 71-7330

PARTS LISTING WITH ASSEMBLY INSTRUCTIONS

Tiger Corporation
3301 N. Louise Ave.
Sioux Falls, SD 57107
1-800-843-6849
1-605-336-7900
www.tiger-mowers.com

TO THE OWNER / OPERATOR / DEALER

All implements with moving parts are potentially hazardous. There is no substitute for a cautious, safe-minded operator who recognizes the potential hazards and follows reasonable safety practices. The manufacturer has designed this implement to be used with all its safety equipment properly attached to minimize the chance of accidents.

BEFORE YOU START!! Read the safety messages on the implement and shown in this manual. Observe the rules of safety and use common sense!

READ AND UNDERSTAND THIS MANUAL! Non-English speaking operators will need to GET THE MANUAL TRANSLATED as needed!



DANGER

FAILING TO FOLLOW SAFETY MESSAGES AND OPERATING INSTRUCTIONS CAN CAUSE SERIOUS BODILY INJURY OR EVEN DEATH TO OPERATOR AND OTHERS IN THE AREA.

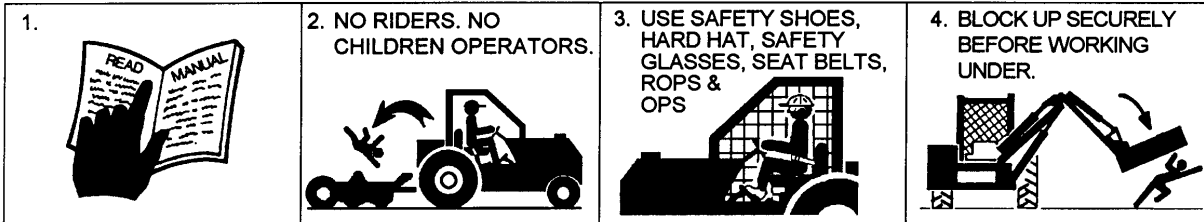

1. Study and understand Operator's Manuals, Safety Decals, and Instructional Decals for tractor and implement to prevent misuse, abuse, and accidents. Practice before operating in a confined area or near passersby.
 ● Learn how to stop engine suddenly in an emergency. Be alert for passersby and especially children

2. Allow no children on or near folding mower or tractor. Allow no riders on tractor or implement. Falling off may cause serious injury or death from being run over by tractor or mower or contact with rotating blades.

3. Operate only with tractor having Roll-Over Protective Structure (ROPS) and with seat belt securely fastened to prevent injury and possible death from falling off or tractor overturn.
 ● Personal Protective Equipment such as Hard Hat, Safety Glasses, Safety Shoes, & Ear Plugs are recommended.

4. Block up or support raised machine and all lifted components securely before putting hands or feet under or working underneath any lifted component to prevent crushing injury or death from sudden dropping or inadvertent operation of controls. Make certain area is clear before lowering or folding

5. Before transporting, put Lift Lever in detent or full-lift position. Install Transport Safety Devices securely on folding mowers. Put Booms securely in Transport Rest.
 ● Folding and Boom Mowers have raised center of gravity. Slow down when turning and on hillsides.

6. Make certain that SMV sign, warning lights, and reflectors are clearly visible. Follow local traffic codes.

7. Never operate with Cutting Head or Folding Section raised if passersby, bystanders, or traffic are in the area to reduce possibility of injury or death from objects thrown by Blades under Guards or mower structure.

8. Before dismounting, secure implement in transport position or lower to ground.
 ● Put tractor in park or set brake, disengage PTO, stop engine, remove key, and wait until noise of rotation has ceased to prevent crushing by entanglement in rotating parts which could cause injury or death.
 ● Never mount or dismount a moving vehicle. Crushing from runover may cause serious injury or death.

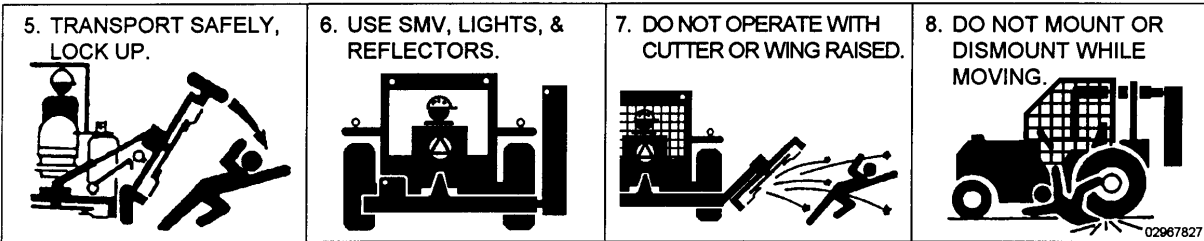

Warranty Information: Read and understand the complete Warranty Statement found in this manual. Fill out the Warranty Registration form in full and return it within 90 days. Make certain the Serial Number of the machine is recorded on the Warranty Card, and form that you retain.

FORWARD

This manual contains information about many features of the Tiger mowing and roadside maintenance equipment. Some of these include: Safety precautions, Assembly instructions, Operations, Maintenance and Parts. This manual will also assist you in the proper break-in, daily care, and troubleshooting of your new mower.

We recommend that you read carefully the entire manual before operating the unit. Also, time spent in becoming fully acquainted with its performance features, adjustments, and maintenance schedules will be repaid in a long and satisfactory life of the equipment.

Troubleshooting - Please, before you call, help us to help you!

Please look at the equipment to observe what is happening, then:

- Classify the problem
 - Hydraulic, electrical or mechanical - Read the trouble shooting section
 - Tractor or Truck chassis - Contact vehicle dealer

- If unable to correct the problem yourself, contact your local Tiger Dealer after gathering:
 - Machine model _____
 - Serial number _____
 - Dealer name _____
 - Detailed information about the problem including results of troubleshooting

Attention Owner / Operator / Dealer: It is your obligation to read, and understand, the warranty information section located at the back of this manual denoting that the purchaser understands the safety issues relating to this machine and has received and will read a copy of this manual.

If at any time, you have a service problem with your Tiger mower, Contact your local dealer for service and parts needed.

MANUFACTURED BY:

Tiger Corporation

3301 N. Louise Ave.

Sioux Falls, SD 57107

1-800-843-6849

1-605-336-7900

www.tiger-mowers.com

DISTRIBUTED BY:

1- _____ - _____ - _____

1- _____ - _____ - _____

TABLE OF CONTENTS

SAFETY SECTION_____	1
ASSEMBLY / MOUNTING SECTION_____	2
OPERATION SECTION_____	3
MAINTENANCE SECTION_____	4
PARTS SECTION_____	5
COMMON PARTS SECTION_____	6
WARRANTY INFORMATION_____	7



1012

This symbol means:

CAUTION – YOUR SAFETY IS AT RISK!

When you see this symbol, read and follow the associated instructions carefully or personal injury or damage may result.

Tiger is a registered trademark.



SAFETY SECTION

SAFETY

A safe and careful operator is the best operator. Safety is of primary importance to the manufacturer and should be to the owner / operator. Most accidents can be avoided by being aware of your equipment, your surroundings, and observing certain precautions. The first section of this manual includes a list of Safety Messages that, if followed, will help protect the operator and bystanders from injury or death. Read and understand these Safety Messages before assembling, operating or servicing this mower. This equipment should only be operated by those persons who have read the Manual, who are responsible and trained, and who know how to do so safely and responsibly.

The Safety Alert Symbol combined with a Signal Word, as seen below, is used throughout this manual and on decals which are attached to the equipment. The Safety Alert Symbol means: **“ATTENTION! BECOME ALERT! YOUR SAFETY IS INVOLVED!”** The symbol and signal word are intended to warn the owner / operator of impending hazards and the degree of possible injury when operating this equipment.

Practice all usual and customary safe working precautions and above all -- remember safety is up to YOU! Only YOU can prevent serious injury or death from unsafe practices.



This is the Safety Alert Symbol. When you see this symbol on your machine or in these instructions, be alert to the potential for personal injury.

CAUTION!



The lowest level of Safety Message; warns of possible injury. Decals located on the equipment with this signal word are Black and Yellow.

WARNING!



Serious injury or possible death! Decals are Black and Orange.

DANGER!



Imminent death / critical injury. Decals are Red and White.

READ, UNDERSTAND, and FOLLOW the following Safety Messages. Serious injury or death may occur unless care is taken to follow the warnings and instructions stated in the Safety Messages. Always use good common sense to avoid hazards. (SG-2)

SAFETY INSTRUCTIONS



SAFETY

PELIGRO!



Si no lee Ingles, pida ayuda a alguien que si lo lea para que le traduzca las medidas de seguridad. *UI /5+

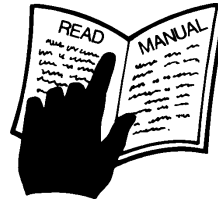

¡ LEA EL INSTRUCTIVO!

DANGER!



Never operate the Tractor or Implement until you have read and completely understand this Manual, the Tractor Operator's Manual, and each of the Safety Messages found in the Manual or on the Tractor and Implement. Learn how to stop the tractor engine suddenly in an emergency! Never allow inexperienced or untrained personnel to operate the Tractor and Implement without supervision. Make sure the operator has fully read and understood the manuals prior to operation. *UI /6+

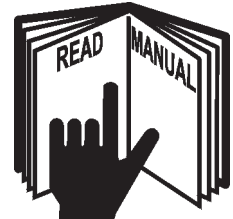

WARNING!



Always maintain the safety decals in good readable condition. If the decals are missing, damaged, or unreadable, obtain and install replacement decals immediately. *UI /7+

WARNING!



Make certain that the "Slow Moving Vehicle" (SMV) sign is installed in such a way as to be clearly visible and legible. When transporting the Equipment use the Tractor flashing warning lights and follow all local traffic regulations. *UI /8+

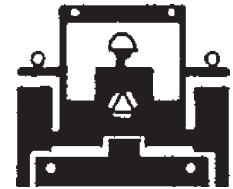

WARNING!



Operate this Equipment only with a Tractor equipped with an approved roll-over-protective system (ROPS). Always wear seat belts. Serious injury or even death could result from falling off the tractor--particularly during a turnover when the operator could be pinned under the ROPS. *UI /9+



WARNING!



Do not modify or alter this Implement. Do not permit anyone to modify or alter this Implement, any of its components or any Implement function. *UI /:+

DANGER!



BEFORE leaving the tractor seat, always engage the brake and/or set the tractor transmission in parking gear, disengage the PTO, stop the engine, remove the key, and wait for all moving parts to stop. Place the tractor shift lever into a low range or parking gear to prevent the tractor from rolling. Never dismount a Tractor that is moving or while the engine is running. Operate the Tractor controls from the tractor seat only. *UI /:+

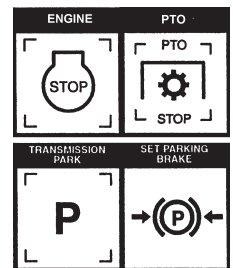

SAFETY

DANGER!



Never allow children or other persons to ride on the Tractor or Implement. Falling off can result in serious injury or death.

*****UI /32+



DANGER!



Never allow children to operate or ride on the Tractor or Implement.

*****UI /33+



WARNING!



Do not mount the Tractor while the tractor is moving. Mount the Tractor only when the Tractor and all moving parts are completely stopped.

34+

*****UI /



DANGER!



Start tractor only when properly seated in the Tractor seat. Starting a tractor in gear can result in injury or death. Read the Tractor operators manual for proper starting instructions. *UI /35+



DANGER!



Never work under the Implement, the framework, or any lifted component unless the Implement is securely supported or blocked up to prevent sudden or inadvertent falling which could cause serious injury or even death. ****UI /36+



DANGER!



Do not operate this Equipment with hydraulic oil leaking. Oil is expensive and its presence could present a hazard. Do not check for leaks with your hand! Use a piece of heavy paper or cardboard. High-pressure oil streams from breaks in the line could penetrate the skin and cause tissue damage including gangrene. If oil does penetrate the skin, have the injury treated immediately by a physician knowledgeable and skilled in this procedure. ***UI /37+



SAFETY

WARNING!



The operator and all support personnel should wear hard hats, safety shoes, safety glasses, and proper hearing protection at all times for protection from injury including injury from items thrown by the equipment. *UI /38+

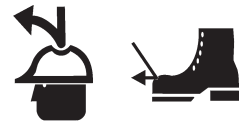

CAUTION!



PROLONGED EXPOSURE TO LOUD NOISE MAY CAUSE PERMANENT HEARING LOSS! Tractors with or without an Implement attached can often be noisy enough to cause permanent hearing loss. We recommend that you always wear hearing protection if the noise in the Operator's position exceeds 80db. Noise over 85db over an extended period of time will cause severe hearing loss. Noise over 90db adjacent to the Operator over an extended period of time will cause permanent or total hearing loss. *Note:* Hearing loss from loud noise [from tractors, chain saws, radios, and other such sources close to the ear] is cumulative over a lifetime without hope of natural recovery. *UI /19+



WARNING!



Transport only at safe speeds. Serious accidents and injuries can result from operating this equipment at unsafe speeds. Understand the Tractor and Implement and how it handles before transporting on streets and highways. Make sure the Tractor steering and brakes are in good condition and operate properly.



Before transporting the Tractor and Implement, determine the safe transport speeds for you and the equipment. Make sure you abide by the following rules:

1. Test the tractor at a slow speed and increase the speed slowly. Apply the Brakes smoothly to determine the stopping characteristics of the Tractor and Implement. As you increase the speed of the Tractor the stopping distance increases. Determine the maximum safe transport speed for you and this Equipment.
2. Test the equipment at a slow speed in turns. Increase the speed through the turn only after you determine that it is safe to operate at a higher speed. Use extreme care and reduce your speed when turning sharply to prevent the tractor and implement from turning over. Determine the maximum safe turning speed for you and this equipment before operating on roads or uneven ground.
3. Only transport the Tractor and Implement at the speeds that you have determined are safe and which allow you to properly control the equipment.



Be aware of the operating conditions. Do not operate the Tractor with weak or faulty brakes. When operating down a hill or on wet or rain slick roads, the braking distance increases: use extreme care and reduce your speed. When operating in traffic always use the Tractor's flashing warning lights and reduce your speed. Be aware of traffic around you and watch out for the other guy. (SG-19)

SAFETY

WARNING!



Never attempt to lubricate, adjust, or remove material from the Implement while it is in motion or while tractor engine is running. Make sure the tractor engine is off before working on the Implement.

*****UI /42+

WARNING!



Periodically inspect all moving parts for wear and replace when necessary with authorized service parts. Look for loose fasteners, worn or broken parts, and leaky or loose fittings. Make sure all pins are properly secured. Serious injury may occur from not maintaining this machine in good working order. *UI /43+



WARNING!



Always read carefully and comply fully with the manufacturers instructions when handling oil, solvents, cleansers, and any other chemical agent. *UI /44+



DANGER!



Never run the tractor engine in a closed building or without adequate ventilation. The exhaust fumes can be hazardous to your health.

*UI /45+

DANGER!



KEEP AWAY FROM ROTATING ELEMENTS to prevent entanglement and possible serious injury or death.

*****UI /46+



DANGER!



Never allow children to play on or around Tractor or Implement. Children can slip or fall off the Equipment and be injured or killed. Children can cause the Implement to shift or fall crushing themselves or others. *UI /47+

SAFETY

DANGER!



NEVER use drugs or alcohol immediately before or while operating the Tractor and Implement. Drugs and alcohol will affect an operator's alertness and coordination and therefore affect the operator's ability to operate the equipment safely. Before operating the Tractor or Implement, an operator on prescription or over-the-counter medication must consult a medical professional regarding any side effects of the medication that would hinder their ability to operate the Equipment safely. **NEVER** knowingly allow anyone to operate this equipment when their alertness or coordination is impaired. Serious injury or death to the operator or others could result if the operator is under the influence of drugs or alcohol. *UI /49+



DANGER!



Operate the Tractor and/or Implement controls only while properly seated in the Tractor seat with the seat belt securely fastened around you. Inadvertent movement of the Tractor or Implement may cause serious injury or death. *UI /4; +

WARNING!



Mow only in conditions where you have clear visibility in daylight or with adequate artificial lighting. Never mow in darkness or foggy conditions where you cannot clearly see at least 100 yards in front and to the sides of the tractor and mower. Make sure that you can clearly see and identify passersby, steep slopes, ditches, drop-offs, overhead obstructions, power lines, debris and foreign objects. If you are unable to clearly see this type of items discontinue mowing. *UI 0/3+

DANGER!



There are obvious and hidden potential hazards in the operation of this Mower. **REMEMBER!** This machine is often operated in heavy brush and in heavy weeds. The Blades of this Mower can throw objects if shields are not properly installed and maintained. Serious injury or even death may occur unless care is taken to insure the safety of the operator, bystanders, or passersby in the area. Do not operate this machine with anyone in the immediate area. Stop mowing if anyone is within 100 yards of mower. *UI 0/4+



DANGER!



All Safety Shields, Guards and Safety devices including (but not limited to) - the Deflectors, Chain Guards, Steel Guards, Gearbox Shields, PTO integral shields, and Retractable Door Shields should be used and maintained in good working condition. All safety devices should be inspected carefully at least daily for missing or broken components. Missing, broken, or worn items must be replaced at once to reduce the possibility of injury or death from thrown objects, entanglement, or blade contact. *UI 0/5+

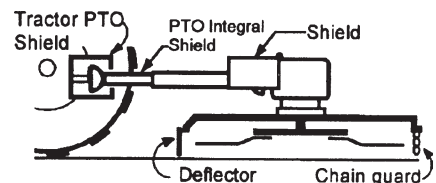

SAFETY

DANGER!



The rotating parts of this machine have been designed and tested for rugged use. However, the blades could fail upon impact with heavy, solid objects such as metal guard rails and concrete structures. Such impact could cause the broken objects to be thrown outward at very high velocities. To reduce the possibility of property damage, serious injury, or even death, never allow the cutting blades to contact such obstacles. *UI O/6+

WARNING!



Extreme care should be taken when operating near loose objects such as gravel, rocks, wire, and other debris. Inspect the area before mowing. Foreign objects should be removed from the site to prevent machine damage and/or bodily injury or even death. Any objects that cannot be removed must be clearly marked and carefully avoided by the operator. Stop mowing immediately if blades strike a foreign object. Repair all damage and make certain rotor or blade carrier is balanced before resuming mowing. *UI O/7+



WARNING!



Many varied objects, such as wire, cable, rope, or chains, can become entangled in the operating parts of the mower head. These items could then swing outside the housing at greater velocities than the blades. Such a situation is extremely hazardous and could result in serious injury or even death. Inspect the cutting area for such objects before mowing. Remove any like object from the site. Never allow the cutting blades to contact such items. **UI O/8+

WARNING!



Mow at the speed that you can safely operate and control the tractor and mower. Safe mowing speed depends on terrain condition and grass type, density, and height of cut. Normal ground speed range is from 0 to 5 mph. Use slow mowing speeds when operating on or near steep slopes, ditches, drop-offs, overhead obstructions, power lines, or when debris and foreign objects are to be avoided. *UI O/9+

WARNING!



Avoid mowing in reverse direction when possible. Check to make sure there are no persons behind the mower and use extreme care when mowing in reverse. Mow only at a slow ground speed where you can safely operate and control the tractor and mower. Never mow an area that you have not inspected and removed debris or foreign material. ***UI O/; +

WARNING!



Do not put hands or feet under mower decks. Blade Contact can result serious injury or even death. Stay away until all motion has stopped and the decks are securely blocked up. *UI O/; +



DANGER!



Replace bent or broken blade with new blades. NEVER ATTEMPT TO STRAIGHTEN OR WELD ON BLADES SINCE THIS WILL LIKELY CRACK OR OTHERWISE DAMAGE THE BLADE WITH SUBSEQUENT FAILURE AND POSSIBLE SERIOUS INJURY FROM THROWN BLADES. ****UI O/32+

SAFETY

WARNING!



Do not mow with two machines in the same area except with Cab tractors with the windows closed. *U O/33+

DANGER!



Rotary and Flail Mowers are capable under adverse conditions of throwing objects for great distances (100 yards or more) and causing serious injury or death. Follow safety messages carefully. **STOP MOWING IF PASSERSBY ARE WITHIN 100 YARDS UNLESS:**

- Front and Rear Deflectors are installed and in good, working condition;
- Mower Head is running close to and parallel to the ground without exposed Blades;
- Passersby are outside the existing thrown-object zone;
- All areas have been thoroughly inspected and all foreign material such as rocks, cans, glass, and general debris has been removed.



NOTE: Where there are grass and weeds high enough to hide debris that could be struck by the blades, the area should be: inspected and large debris removed, mowed at an intermediate height, inspected closely with any remaining debris being removed, and mowed again at desired final height. *UDO/3+



DANGER!



Use extreme caution when raising the Mower head. Stop the Blades from turning when the Mower Head is raised and passersby are within 100 yards. Raising the Mower head exposes the Cutting Blades which creates a potentially serious hazard and can cause serious injury by objects thrown from the Blades or by contact with the Blades. *****UDO/4+

DANGER!



Be particularly careful in transport. The Mower has raised the center of gravity for the tractor and has increased the possibility of overturn. Turn curves or go up slopes only at low speed and using a gradual turning angle. Slow down on rough or uneven surfaces. *UDO/5+



WARNING!



Never Leave the mower unattended while the head is in the raised position. The mower could fall causing serious injury to anyone who might inadvertently be under the mower. *****UDO/6+



WARNING!



The rotating parts of this machine continue to rotate even after the Tractor has been turned off. The operator should remain in his seat for 60 seconds after the brake has been set, the PTO disengaged, the tractor turned off, and all evidence of rotation has ceased. *UDO/7+

“Wait a minute...Save a life!”

SAFETY



Relieve hydraulic pressure prior to doing any maintenance or repair work on the Implement. Place the Mower Head on the ground or securely supported on blocks or stands, disengage the PTO, and turn off the engine. Push and pull the control Levers or Joystick several times to relieve pressure prior to starting any maintenance or repair work. *UDO /8+

DANGER!



Always keep a careful lookout and use extreme care when working around overhead obstructions. Never allow the Mower head or boom within 10 feet of any power line. When working close to overhead power lines consult your electric company for a safe code of operation. *UDO /9+

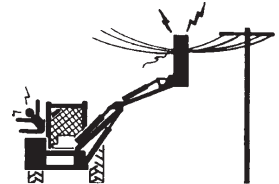

DANGER!



When transporting Boom Mower on a truck or trailer, the height or width may exceed legal limits when the boom is in the transport position. Contact with side or overhead structures or power lines can cause property damage or serious injury or death. If necessary lower boom to reduce height and/or remove mowing head to reduce width to the legal limits. *UDO /; +

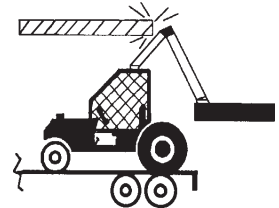

DANGER!



Never operate the Tractor and Mower Unit without an OPS (Operators Protective Structure) or Cab to prevent injury from objects thrown from ground or from overhead trimming. Stop mowing if workers or passersby are within 100 yards. *UDO /; +



DANGER!



Each Rear Wheel must have a minimum of 1500 pound contact with the surface to prevent lateral instability and possible tip-over which could result in serious bodily injury or even death. Widen the wheel tread and add weights if needed. Refer to the mounting instructions or call Customer Service if you need assistance with Counterweight Procedure. *UDO /33+



DANGER!



Always disconnect the wire leads from the mower pump solenoid before performing service on the Tractor or Mower. Use caution when working on the Tractor or Mower. Tractor engine must be stopped before working on Mower or Tractor. The Mower Blades could inadvertently be turned on without warning and cause immediate dismemberment, injury or death. ***UDO /34c+

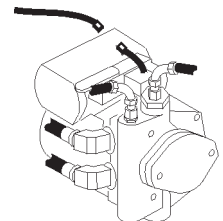

DANGER!



The flail cutter shaft is designed for standard rotation (same rotation as the tractor wheels during forward travel). **Never operate the cutter shaft in the reverse rotation.** Operating this mower in reverse rotation may cause objects to be thrown out the front of the mower head.

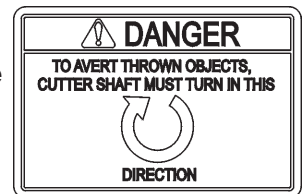

SAFETY

WARNING!



Engine Exhaust, some of its constituents, and certain components contain or emit chemicals known to the state of California to cause cancer and birth or other reproductive harm.

WARNING!



Battery posts, terminals and related accessories contain lead and lead compounds, chemicals known to the state of California to cause cancer and birth or other reproductive harm. **Wash hands after handling!**

Tiger mowers use balanced and matched system components for blade carriers, blades, cutter-shafts, knives, knife hangers, rollers, drive-train components and bearings. These parts are made and tested to Tiger specifications. Non-genuine “will fit” parts do not consistently meet these specifications. The use of “will fit” parts may reduce mower performance, void mower warranties and present a safety hazard. Use genuine Tiger mower parts for economy and safety.

SEE YOUR  DEALER

In addition to the design and configuration of this Implement, including Safety Signs and Safety Equipment, hazard control and accident prevention are dependent upon the awareness, concern, prudence, and proper training of personnel involved in the operation, transport, maintenance, and storage of the machine. Refer also to Safety Messages and operation instruction in each of the appropriate sections of the Tractor and Equipment Manuals. Pay close attention to the Safety Signs affixed to the Tractor and Equipment. (SG-18)

SAFETY

DANGER

FAILING TO FOLLOW SAFETY MESSAGES AND OPERATING INSTRUCTIONS CAN CAUSE SERIOUS BODILY INJURY OR EVEN DEATH TO OPERATOR AND OTHERS IN THE AREA.



1. Study and understand Operator's Manuals, Safety Signs, and Instructional Decals for tractor & flail mower to prevent misuse, abuse, & accidents. Practice before operating mower in a confined area or near passersby.
 - Learn how to stop engine suddenly in an emergency. Be alert for passersby and especially children.
2. Allow no children on or near implement or tractor. Allow no riders on tractor or implement. Falling off can cause serious injury or death from being runover by tractor or mower or contact with Flail Mower Blades.
3. Operate only with tractor having Roll-Over Protective Structure (ROPS) and with seatbelt fastened securely and snugly to prevent injury and possible death from falling off or tractor overturn. Personal Protective Equipment such as Hard Hat, Safety Glasses, Safety Shoes, and Ear Plugs are recommended.
4. Block up or support raised machine and all lifted components securely before putting hands or feet under or working underneath any lifted component to prevent crushing injury or death from sudden dropping or inadvertent operation of controls. Make certain that area is clear before lowering or folding.
 - Install **Restrictor in folding circuit to slow down lowering and unfolding if action is faster than is desirable.
5. Before transporting, put Lift Lever in detent or full-lift position. Install Transport Safety Devices securely on folding implements. Slow down when turning and on hillsides.
 - Install **Restrictor in folding circuit to slow down lowering and unfolding if action is faster than is desirable.
6. Make certain that SMV sign, Warning Lights, and Reflectors are clearly visible. Follow local traffic codes.
7. Never operate with Flail Mower or Folding Section raised if passersby, bystanders or traffic are in the area to reduce possibility of injury or death from objects thrown by Blades under Shields or implement structure.
8. Before dismounting, secure flail mower in transport position or lower to ground.
 - Put tractor in park or set brake, disengage PTO, stop engine, remove key, and wait until noise of rotation has ceased to prevent entanglement in rotating parts which may cause injury or death.
 - Never mount or dismount a moving vehicle. Crushing from runover may cause injury or death.

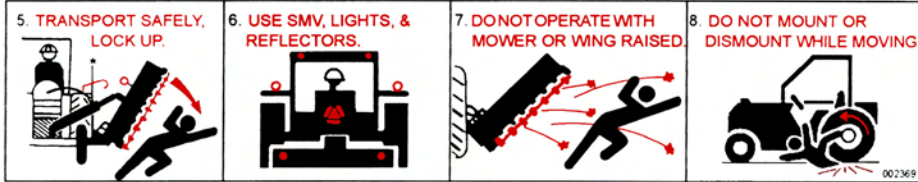

PART NO.
LOCATION

002369
HYDRAULIC TANK

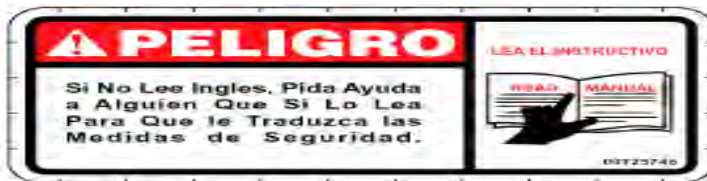

00725746
INSIDE OF CAB

DANGER

THROWN OBJECTS

CUTTING BLADES



KEEP AWAY - ROTATING BLADES

BEING HIT BY THROWN OBJECTS OR CONTACTING ROTATING BLADES CAN CAUSE INJURY OR DEATH.

- Stop mowing if passersby enter the area of thrown objects (See Operator's Manual).
- Use special care if Mower Head or Wing is raised off the ground. (See Manual).
- Operate only if all Guards-Deflectors are in place and in good condition.

00769737

00769737
MOWER DECK

SAFETY



PART NO.
LOCATION

00758194
MOWER DECK



02962764
MAIN BOOM, SECONDARY BOOM, MAIN FRAME



02962765
MAIN FRAME

02965262
HYDRAULIC TANK

SAFETY

DANGER

CUTTING BLADES



THROWN OBJECTS



PART NO.
LOCATION

02967668
MOWER DECK

KEEP AWAY - ROTATING BLADES

BEING HIT BY THROWN OBJECTS OR CONTACTING ROTATING BLADES CAN CAUSE INJURY OR DEATH

- Stop mowing if passersby enter the area of thrown objects. (See Operator's Manual)
- Use special care when Flail or Wing is raised off the ground. (See Oper. Manual)
- Operate only if all Guards-Deflectors are in place and in good condition.

02971123
HYDRAULIC TANK



03200285
OUTSIDE OF CAB

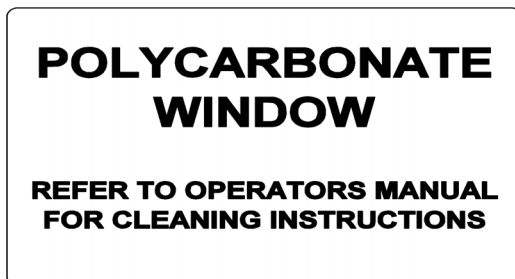

22645
INSIDE OF CAB

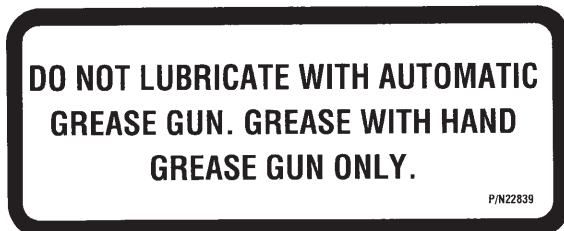

22839
MOWER DECK

SAFETY



PART NO.
LOCATION

22840
INSIDE OF CAB



24028
MOWER DECK

25387
INSIDE OF CAB



10" x 5.5" 31522
MOWER DECK, MAIN BOOM
18.25" x 10" 31523
HYDRAULIC TANK
13.5" x 7" 31513

SAFETY

WARNING

Valve section TF3009 with detented float to be used with only Boom Flail mower. DO NOT operate a Boom rotary mower with the float section installed.

P/N 27001

PART NO.
LOCATION

27001
INSIDE OF CAB

LOCK

↑

TRAVEL LOCK

↓

UNLOCK

31935

31935
INSIDE OF CAB

DANGER

1. EACH REAR WHEEL MUST HAVE A MINIMUM OF 1500 POUNDS CONTACT WITH THE SURFACE TO PREVENT LATERAL INSTABILITY AND POSSIBLE TIP-OVER WITH BODILY INJURY. WIDEN WHEEL TREAD AND ADD WEIGHTS IF NEEDED. SEE MANUAL OR CALL TIGER CUSTOMER SERVICE FOR COUNTERWEIGHT PROCEDURE.
2. TRANSPORT CAREFULLY! SLOW DOWN EVEN MORE ON SLOPES AND WHEN TURNING; NEVER TURN UP A SLOPE SHARPLY OR AT HIGH SPEED; AND USE EXTRA CARE IN ROUGH OR BUMPY AREAS TO PREVENT OVERTURN AND POSSIBLE CRUSHING INJURY OR DEATH. IF YOUR VIEW TO THE REAR IS BLOCKED, IT IS YOUR RESPONSIBILITY TO INSTALL MIRRORS THAT PROVIDE A REAR VIEW TO PREVENT ACCIDENTS FROM BLIND SPOTS.
3. REAR-MOUNTED BOOM MOWERS MOVE CENTER OF GRAVITY TO THE REAR AND REMOVE WEIGHT FROM FRONT WHEELS. ADD FRONT BALLAST UNTIL AT LEAST 20% OF TRACTOR'S WEIGHT IS ON FRONT WHEELS TO PREVENT REARING UP, LOSS OF STEERING CONTROL, AND POSSIBLE INJURY.
4. NEVER OPERATE UNIT WITHOUT AN OPS (OPERATOR PROTECTIVE STRUCTURE) OR CAB TO PREVENT INJURY FROM OBJECTS THROWN FROM GROUND AND OVERHEAD TRIMMING. STOP CUTTING IF ANYONE IS WITHIN 100 YARDS.
5. KEEP THE BOOM AND CUTTERHEAD AT LEAST 10 FEET FROM ELECTRIC LINES AND PIPE LINES TO PREVENT ACCIDENTAL CONTACT AND POSSIBLE SERIOUS INJURY OR EVEN DEATH.
6. WHEN TRANSPORTING BOOM MOWERS ON A TRUCK OR TRAILER, THE HEIGHT OR WIDTH MAY EXCEED LEGAL LIMITS. CONTACT WITH SIDE OR OVERHEAD STRUCTURES OR POWER LINES CAN CAUSE SERIOUS INJURY OR DEATH. LOWER BOOM TO REDUCE HEIGHT AND/OR REMOVE MOWING HEAD TO REDUCE WIDTH TO THE LEGAL LIMITS, IF NEEDED.

32707

32707
HYDRAULIC TANK

DANGER

TO AVERT THROWN OBJECTS,
CUTTER SHAFT MUST TURN IN THIS

↻

DIRECTION

42350

42350
MOWER DECK

SAFETY

ATTENTION

**SERVICE HYDRAULIC SYSTEM
WITH UNIVERSAL TRACTOR
HYDRAULIC OIL.**

32708

PART NO.
LOCATION

32708
HYDRAULIC TANK

CAUTION

For your safety and to guarantee optimum product reliability, always use genuine TIGER replacement parts. The use of inferior "will-fit" parts will void warranty of your TIGER implement and may cause premature or catastrophic failure which can result in serious injury or death. If you have any questions concerning the repair parts you are using, contact TIGER, 3301 N. LOUISE AVE., SIOUX FALLS, SD 57107

32709

32709
INSIDE OF CAB

33224
MOWER DECK

Tiger™

33438
MAIN BOOM

SAFETY

PART NO.
LOCATION

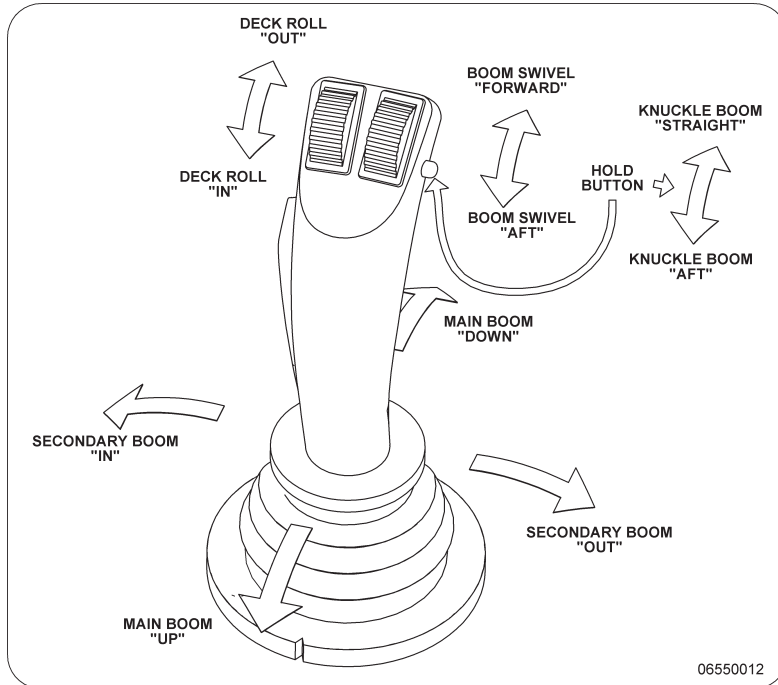

06550012
INSIDE OF CAB

MOWING SAFETY TIPS

- 1 Read & understand the Operators Manual.
- 2 Wear Your Seat Belt.
- 3 Keep all shields and guards in place.
- 4 Make sure equipment is in proper working condition.
- 5 Never attempt to get off or on a moving tractor.
- 6 Never allow riders on tractor or equipment.
- 7 Only start the tractor from the seat with the key.
- 8 Always inspect the area before mowing. Remove all foreign debris.
- 9 Always keep bystanders and coworkers a minimum of 300 feet away.
- 10 Never allow the mower blades to contact solid objects or foreign material.
- 11 Never approach rotating elements.
- 12 Disengage the PTO, place transmission in "Park", set parking brake, shut off engine, and remove key and wait until all rotating motion has stopped before leaving seat.

Tiger

33743

33743
INSIDE OF CAB

SAFETY

PART NO.
LOCATION



RED 42399
REFLECTIVE TAPE
MOWER DECK

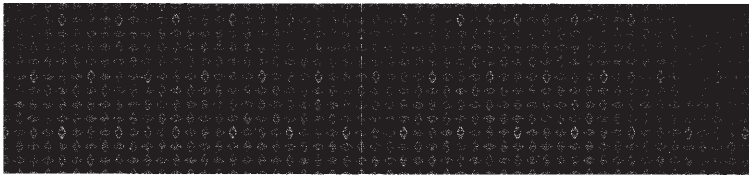

AMBER 424006
REFLECTIVE TAPE
MOWER DECK



6T3217
MOWER DECK



6T3219
INSIDE OF CAB

6T3220
FRONT PUMP MOUNT

SAFETY

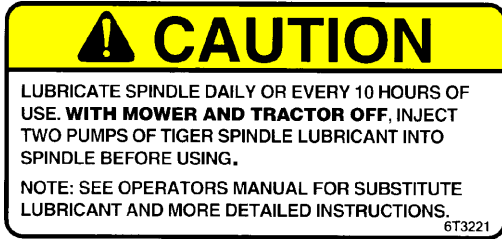

PART NO.
LOCATION

6T3221
INSIDE OF CAB

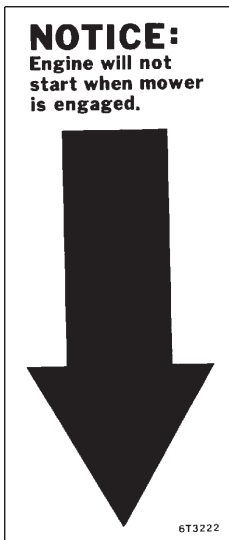

6T3222
INSIDE OF CAB



6T3224
MOWER DECK

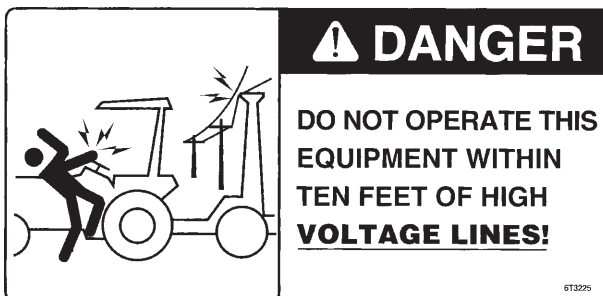

6T3225
INSIDE OF CAB

SAFETY

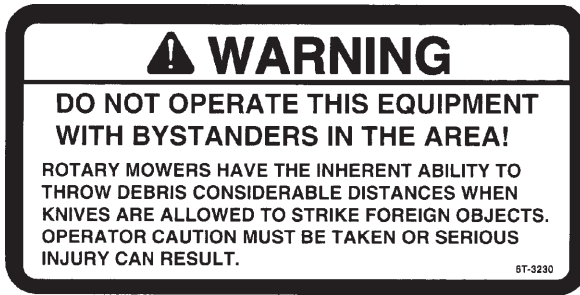

PART NO.
LOCATION

6T3230
INSIDE OF CAB



6T3231
INSIDE OF CAB



6T3233
HYDRAULIC TANK



6T3234
INSIDE OF CAB



6T3236
MOWER DECK

SAFETY

⚠ WARNING

WHEN CUTTING HEAVY BRUSH,
BLADE BOLTS SHOULD BE
INSPECTED HOURLY AND
RETORQUED TO 600 FT. LBS.

6T-3237

6T3237

PART NO.
LOCATION
6T3237
INSIDE OF CAB

<p>DOWN ↑ MAIN BOOM ↓ UP</p>	<p>OUT ↑ SECONDARY BOOM ↓ IN</p>	<p>OUT ↑ DECK ROLL ↓ IN</p>	<p>CLOSE ↑ SHIELD ↓ OPEN</p>	<p>FORWARD ↑ SWIVEL ↓ AFT</p>	<p>IN ↑ SWITCH / KNUCKLE ↓ OUT</p>
---	---	--	---	--	---

06550008
INSIDE OF CAB

<p style="text-align: center;">⚠ WARNING</p> <p style="font-size: x-small;">IT IS RECOMMENDED THAT THE BOLT AND LOCK NUT BE REPLACED WHENEVER BLADES ARE REPLACED. REPLACE THESE ANY TIME THEY ARE DAMAGED OR WORN AS FAILURE TO DO SO CAN LEAD TO BLADES COMING OFF CAUSING SERIOUS INJURY OR DEATH.</p>	<p style="text-align: center;">IMPORTANT</p> <ul style="list-style-type: none"> • WHEN REPLACING BLADES, IT IS RECOMMENDED THAT ALL BLADES BE REPLACED FOR PROPER BALANCE TO AVOID EXCESSIVE VIBRATIONS WHICH CAN DAMAGE SPINDLE ASSEMBLY. • SEE YOUR OPERATOR'S MANUAL FOR PROPER INSTALLATION INSTRUCTIONS. <p style="text-align: right; font-size: x-small;">6T-3243</p>
--	--

6T3243
INSIDE OF CAB

GREASING INSTRUCTIONS

CUTTER SHAFT BEARING

GREASE EVERY 8 HRS. OR DAILY

NOTE: If unusual environmental conditions exist-extreme temperatures, moisture, or contaminants-more frequent lubrication is required.

6T3249A

6T3249A
MOWER DECK

GREASING INSTRUCTIONS

GROUND ROLLER BEARING

GREASE EVERY 8 HRS. OR DAILY

NOTE: If unusual environmental conditions exist-extreme temperatures, moisture, or contaminants-more frequent lubrication is required.

6T3261

6T3261
MOWER DECK

SAFETY



TB1011
MOWER DECK



Tiger Corporation

800-843-6849
 www.tiger-mowers.com

Description	Application	General Specification	Recommended Lubricant
Tractor Hydraulics	Reservoir	JD-20C	Mobilfluid® 424
Mower Hydraulics Cold Temperatures 0°F Start-up Normal Temperatures 10°F Start-up Normal Temperatures 15°F Start-up High Operating Temperatures Above 90°F Ambient	Reservoir	ISO 46 Anti-Wear/ Low Temp JD-20C ISO 46 Anti-Wear ISO 100 Anti-Wear	Mobil DTE® 15M Mobilfluid® 424 Mobil DTE® 25 Mobil DTE® 18M
Flail Rear Gearbox	Reservoir	PAO Synthetic Extreme Pressure Gear Lube	Mobilube SHC® 75W-90, Mobil 1 Synthetic Gear Lubricant
Cutter Shaft and Ground Roller Shaft (Flail)	Grease Gun	Lithium Complex, NLGI 2 ISO 320	Mobilgrease® CM-S
Drive Shaft Coupler (Rotary and Flail) Drive Shaft Yoke, U - Joint and Stub Shaft	Grease Gun	Lithium Complex, NLGI 2 ISO 320	Mobilgrease® CM-S
Boom Swivel, Boom Cylinder Pivots (Rotary and Flail Boom Type)	Grease Gun	Lithium Complex, NLGI 2 ISO 320	Mobilgrease® CM-S
Deck Boom Pivot & Deck Stop Adjustment (Rotary and Flail)	Grease Gun	Lithium Complex, NLGI 2 ISO 320	Mobilgrease® CM-S
Deck Spindle (Rotary)	Grease Gun	Tiger Spindle Lubricant	Tiger Part #25351

For Mobil product information, availability, or technical information, call 1-800-662-4525.

Tiger PN 34852

34852
HYDRAULIC TANK

SAFETY

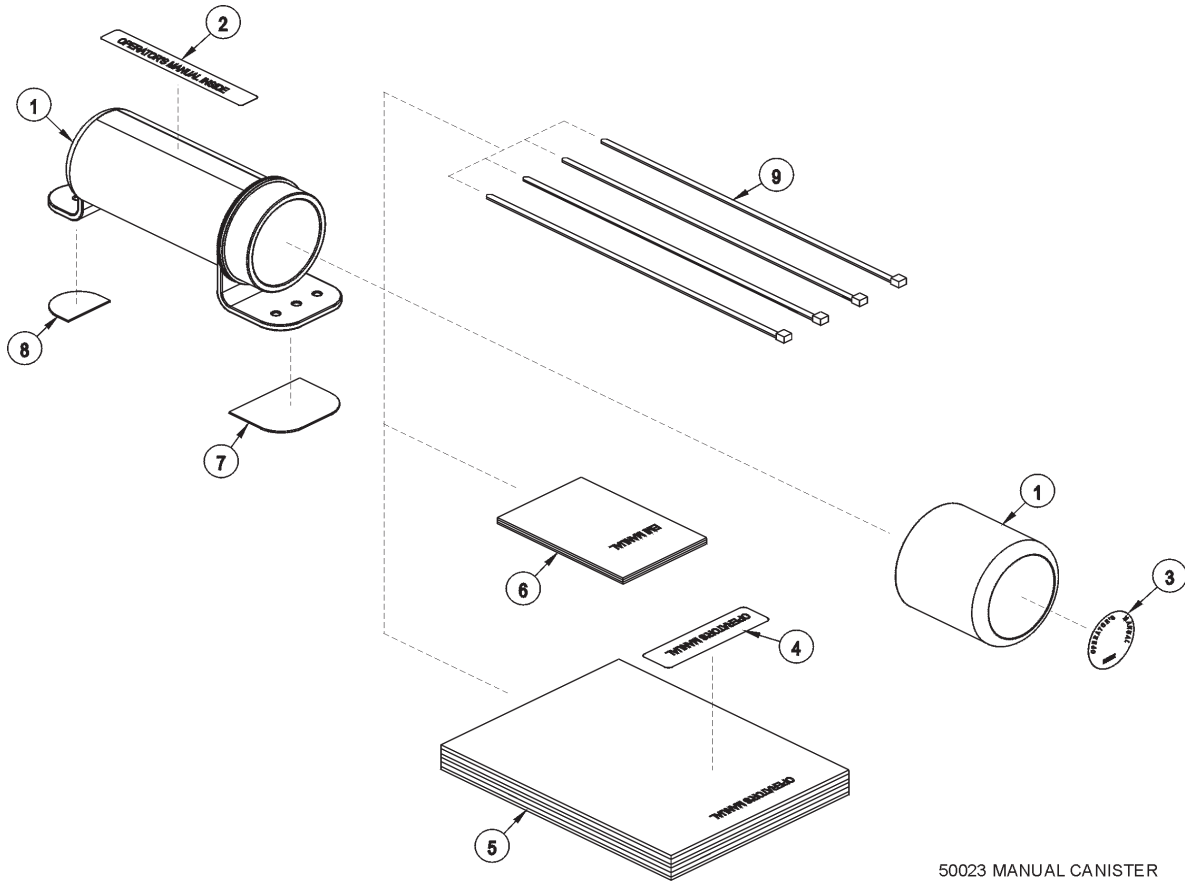

ITEM	PART NO.	QTY.	DESCRIPTION
	50023	AVAIL	MANUAL CANISTER COMPLETE
1	00776031	1	ROUND MANUAL CANISTER
	33997	1	DECAL, SHEET, MANUAL CANISTER
2		*	DECAL
3		*	DECAL
4		*	DECAL
5	*	AVAIL	SPECIFIC PRODUCT MANUAL
6	33753	1	E M I SAFETY MANUAL
7	34296	1	FRONT ADHESIVE PAD
8	34297	1	REAR ADHESIVE PAD
9	6T1823	4	ZIP TIE 14" LONG

NOTE:

The manual canister can be bolted, zip tied or adhered to a variety of surfaces. Locate a protected area within the view of the operator. Then select an installation method and attach the canister. **CAUTION - AVOID DRILLING HOLES INTO UNKNOWN AREAS**, wires and other parts may be located behind these areas. When adhering the canister to a surface, thoroughly clean that surface before installing the canister.

SAFETY

FEDERAL LAWS AND REGULATIONS

This section is intended to explain in broad terms the concept and effect of federal laws and regulations concerning employer and employee equipment operators. This section is not intended as a legal interpretation of the law and should not be considered as such.

Employer-Employee Operator Regulations

U.S. Public Law 91-596 (The Williams-Steiger Occupational and Health Act of 1970) OSHA

This Act Seeks:

“...to assure so far as possible every working man and woman in the nation safe and healthful working conditions and to preserve our human resources...”

DUTIES

Sec. 5 (a) Each employer-

(1) shall furnish to each of his employees employment and a place of employment which are free from recognized hazards that are causing or are likely to cause death or serious physical harm to his employees;

(2) shall comply with occupational safety and health standards promulgated under this Act.

(b) Each employee shall comply with occupational safety and health standards and all rules, regulations and orders issued pursuant to this Act which are applicable to his own actions and conduct.

OSHA Regulations

OSHA regulations state in part: “At the time of initial assignment and at least annually thereafter, the employer shall instruct every employee in the safe operation and servicing of all equipment with which the employee is, or will be involved.”

Employer Responsibilities:

To ensure employee safety during Tractor and Implement operation, it is the employer’s responsibility to:

1. Train the employee in the proper and safe operation of the Tractor and Implement.
2. Require that the employee read and fully understand the Tractor and Implement Operator’s manual.
3. Permit only qualified and properly trained employees to operate the Tractor and Implement.
4. Maintain the Tractor and Implement in a safe operational condition and maintain all shields and guards on the equipment.
5. Ensure the Tractor is equipped with a functional ROPS and seat belt and require that the employee operator securely fasten the safety belt and operate with the ROPS in the raised position at all times.
6. Forbid the employee operator to carry additional riders on the Tractor or Implement.
7. Provide the required tools to maintain the Tractor and Implement in a good safe working condition and provide the necessary support devices to secure the equipment safely while performing repairs and service.

Child Labor Under 16 Years of Age

Some regulations specify that no one under the age of 16 may operate power machinery. It is your responsibility to know what these regulations are in your own area or situation. (Refer to U.S. Dept. of Labor, Employment Standard Administration, Wage & Home Division, Child Labor Bulletin #102.)

SAFETY

5 GG9 A 6 @ MG9 7 HCB

5 GG9 A 6 @M

6 YZcfY UHya dhjb['hc'a ci bhnci f' H][Yf'a ck Yfz'h]g'ja dcfhUbh
hc' fYUX'Ub'i bXYfghUbX' U''cZ H Y' GUZYmIA YggU[Yg'jb'H Y'GUZYm
'GYWjcb'cZH Jg'a Ubi U"

Ô@&Á&{ }|c'Á@{ ^} o'á o'á aá • o'á@Á aá a' Áá o'á Á a'Á~|Á@|ÁáÁ[ÁÁ
• @!áá^• ÉÁÁ a'Á&|áá Á@Áááá |Á [á^|Á Á@Áá]| |ááÁ } ^Á |Á@Á [, ^|Á^&ááÁ



OE, á•Á•^ÁÁ[[|Áá É@ á o'Á |Á |Á o'Á Áá o'Á áÁá^Á@áá Á áá•É

Ü^ááÁá áÁ } á^|• áá áÁ@Á } á^Áá•^ { á|Á^ &á } Áá • d' &á } • Áá^ |Áááá { } áá * Áá Á [~ } c
^ [~ |Áá^ |Á [, ^|ÉÁÜ^~|Á Á@Ááá• Á^ &á } Á Á@Á áá ~ áá |Áá^ áá |Áá • d' áá } • Áá |Áá &ááá }
] áá• É (ASM-C-0001)

HF 57 HCF DF 9 D5 F 5 HCB

OE Ü^ { [ç^Áá @áá áÁ^~Á@á áÁc'] • É

OE Öá & } } ^ & áááá |Ááá |Á^ |Á [{ Áá [c@ááá |á • É

OE Ü^ { [ç^Á } * á^Á ááÁ áá |Á • É |Ááá^Á@ [áÁ |Ááá••Á [] o'Á ~ ||^É

OE Ü^ { [ç^Á |Á^ * Á [{ Áááá |Ááá áá * Á @|Á^ áá ~ áá ^Áá áÁ^ {] Á [~ } o'Á á |Áá^ áááá @ áÉ

OE Ü^ { [ç^Áá ^Á [] o'Á ^á @ Áá áÁ ^á @Á^] | | • É

OE Üáá^Á@Áááá |Á } d' Ááá É áá • Áá áÁ^ { [ç^Á@Áá @áá áÁ^~Á^ ááá @Á^ • É

(ASM-JD-0001)

7 F 5 B? G<5 : H' 5 8 5 DH9 F

GA^&••á^Á^ { [ç^Á@Á^ |Ááá &^ , •Á [{ Á@Áááá |Ááá ~ ||^ ÉÁ@ } Áá • áá |Áááá |Ááá |Áá
• @ááááá c'ÁÁ Á@Á^ ||^ Áá áááá • &^ , • Áá áÁ |Áá , áá @ |Áá Á @ , } Áá Á@Ááá• Á^ &á } É
(ASM-JD-0051)

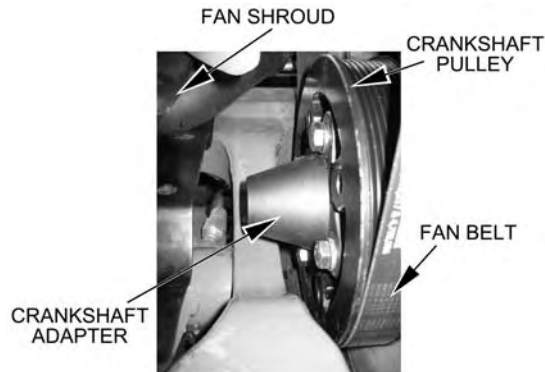

5 GG9 A 6 @M

8 F=J9 G<5 : H/ ' : FCBH'DI AD'ACI BH=B;

Q•cahÁ}æ^iÁ|æ^Á}Áæ&f|Á} *á^Á•á *Á[|oÁæ}áÁ| & , æ @!•Áæ Á @ , }Á ÁæoÁÚ^&ç} ÉÁ
 Ö!^æ^Á|^ç^Á^&ç} Á Á@Áiá^•@eoa}áÁ•cahÁ{| Á@Áæ^Á Á@Á} *á^Á{| }æd ^}ÉÁ
 U) &^Á[^ Á@æ^Á@Á|^ç^Á^&ç} Á Á|æ^ÉÁ|oÁ Á}æ^iÁ|æ^Á•á *Á[|oÁæ}áÁ| & , æ @!•Áæ Á
 • @ , }Á ÁæoÁÚ^&ç} ÉÁQ•cahÁ @eoa}áÁ Áiá^•@eoa@ ^ * @Á] ^} á *Áæ}áÁ d Áiá^•@eoa|^ç^ÉÁ
 Ú@eoa}áÁ|^ç^Á[\ ^ Á @ ^ |áÁ^Áæ} ^áÉÁ @eoa[^ Á [oÁ } ^ i oÁæ}áÁ|^ç^ÉÁ } Á @eoa
 Fí €ÉÁ}áÁ@} Á •cahÉÁ} Á@Á [&@ Á } Á@Á @eoa}áÁ [\ ^ Á æ}áÁ @ , }Á Á æç ^ Á Á [| , É
**G UziYbX'a i ghVY]bgHU`YX]b VcfffYwcf]YbHU]cbzZU]i fYlc`Xc`gc`a UnifYgi`h]b`XUa U] Y`lc`
 fUWcf`UbX#cf`Xf]j Yg UZH`Ce`Á } •cahæ} Á Á @eoa}áÁ •cahÁ {] Á [^ } ÉÁ^çÉÁ •cahÁ {] ÉÁ
 Ce`Á {] Á Á & ^ Á ÉÁ •cahÁiá^•@eoa}Á Á {] Á @eoa@ Á }áÁ Áiá^•@eoa @ ^ |áÁ Á [Á
 { [\ ^ Á @ Á Á Áæ}áÁ { } Á }æç}áÁ {] Á @ ^ •á ÉÁv @ } Á }á }á *Á [|oÁ } Áiá^•@eoa}áÁ
 áiá^•@eoa}áÁ & @ & Á Á @ ^ • ÉÁ}áÁ * ^ ÉÁ Á {] ÉÁ {] Á [^ } ÉÁiá^•@eoa}áÁ [^ }á * Á |æ^Á Á
 ^ } ^ Á Á Áæ}áÁ } Áiá^•@eoa}áÁ }áÁ Á [\ ^ Á } Áiá^•@eoa}áÁ } É**

75I HCB. 8C' BCH'GH5 FH'H<9 HF57 HCF' I BH=@5 @@< CG9G'5 F9'5 HH57 <98 ZH5 B?`
 G: =@@8 'K #k`DFCD9F`C=@5 B8`65 @@J5 @9G'5 F9`CD9B`GH5 FHB; `5H'H<G`HA9`
 K=@75I G9`G9F`C I G'85 A5; 9`HC`H<9`DI AD` (ASM-JD-0007)

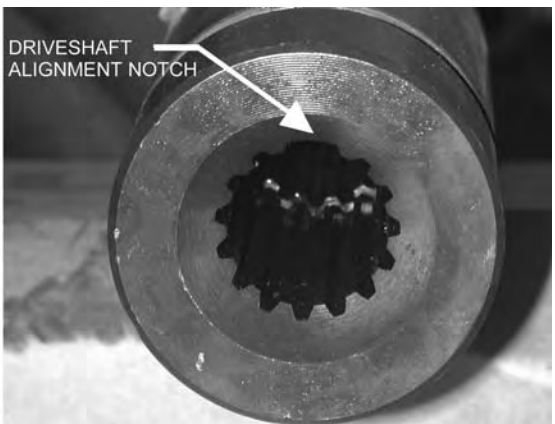
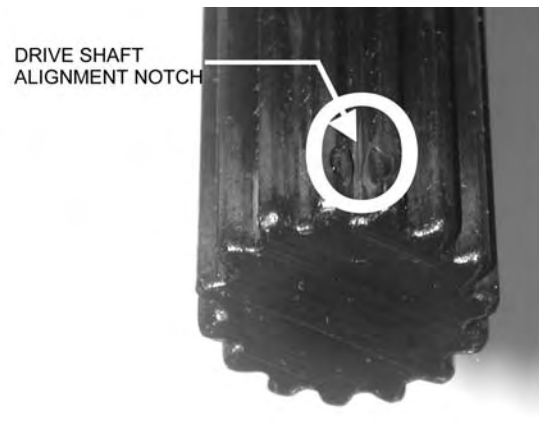

58>I GH=B; `F95 F`K <99 @G

Üæ^Á^æÁ Áæ&f|Á} d Áæ É ç}á ÉÁÁ c`ck`h Y]bgf]i W]cbg`j]b`h Y`fUWcf`ck bYfg
 a Ubi U`Zcf`UX1 gh]b[`HfYg`UbX`f]a g ÉÁV@^ÁæÁ @^| Á WUVÁ Á Áæb`ç`áÁ Á@Á æ ^•c
 • ^ç}á ÉÁUVÒÁÁ @ Á æ Á ^`á^Á , æç}á Á@Á @^| Á Á] [] •æ^Áæ^Á Á Áæ&f| ÉÁOÉ [Áæ^
 } [ç^Á Áæ^Á æç}á^•çç}á • Á @ } Á ç}á] [] ç}á Á Áæ^Á ÉÁOÉ | Áæ^Á Á •cahæ} ÉÁÁ Á^•oÁ
 \ æ^Á@ÁæÁ @^| Á { [ç^Á Áiá^•Á } Á •cahæ} Á Á@Á [, ^ ÉÁ (ASM-B-0001)



5 GG9 A6 @M

: 9B89F`AC8 = 75HCB

QÁ |á^!Á Áe[ãÁ[[{ Á c!-!^} &^Á ã@Á ~!Á ãd |É@Á ã @Á ã^Á} á^!Á @ ~!á^Á &^ cÁ Á
• @ ,) Á^| , ÉÁ ^-!^Á &^ cÁ * Á@Á} á^!É ã \ Á@Á [[!Á ã Á@Á} &^ cÁ ãd Á@Á} á^!Á Á |É
ç^} cÁ &^ ã@Á • ÉÁ Éc^!Á &^ cÁ * Á@Á} á^!É ã] | Á ã Á &^ Á Á@Á á^! • É (ASM-JD-0222)



5 GG9 A 6 @M

DC @M7 5 F 6 CB5H9 'G5 : 9 HMK -B8 CK

PUVÒKQ • cãġ * Ácã[[{ Á [, ^!Á~ a• Ácãġ Á Ácãġ @Ácãġ ġ ġ , • Ácãġ] cãġ Ácãġ Á
] | c & cãġ cãġ [| & cãġ] cãġ ġ ġ , ÉV @ Á @ ġ Ácãġ] ^ Ácãġ | Ácãġ [~ } cãġ * Ácãġ cãġ Ácãġ ^ É
 FÉÖã & } ^ & cãġ cãġ @ & Ácãġ [| ÉV ^ [cãġ @ Ácãġ @ Ácãġ Ácãġ [| É ġ ġ , Ácãġ Ácãġ [{ Ácãġ | Ácãġ
 à Ácãġ [cãġ * Ácãġ * ^ ġ ġ • ÉV • ÉV ^ [cãġ Ácãġ cãġ @ Ácãġ ġ ġ , É
 GÉV ^ [cãġ @ Ácãġ cãġ * Ácãġ , cãġ Ácãġ á Ácãġ & cãġ Ácãġ | Ácãġ Ácãġ [| Ácãġ ġ ġ , É
 HÉV cãġ Ácãġ { cãġ Ácãġ Ácãġ @ • cãġ Ácãġ cãġ Ácãġ cãġ { Ácãġ @ Ácãġ Ácãġ & Ácãġ à Ácãġ cãġ É
 | ÉV • cãġ Ácãġ Ácãġ & Ácãġ à Ácãġ cãġ } Ácãġ [| & cãġ] cãġ Ácãġ cãġ * Ácãġ @ Ácãġ } cãġ Ácãġ [{ Ácãġ | Ácãġ] cãġ [| cãġ] É
 í ÉV • cãġ Ácãġ cãġ * Ácãġ , cãġ Ácãġ [cãġ Ácãġ [{ Ácãġ Ácãġ [| Ácãġ ġ ġ , Ácãġ Ácãġ [| & cãġ] cãġ É
 î ÉV • cãġ Ácãġ [| & cãġ] cãġ Ácãġ ^ { à | Ácãġ Ácãġ Ácãġ cãġ cãġ * Ácãġ á Ácãġ] | Ácãġ cãġ , cãġ É
 ï ÉV cãġ Ácãġ cãġ ġ * Ácãġ Ácãġ } Ácãġ] ^ Ácãġ [cãġ ġ ġ , ^ Ácãġ [cãġ Ácãġ] | Ácãġ Ácãġ Ácãġ [| É
 ġ ġ , Ácãġ @ Ácãġ { { Ácãġ & ^ , É
 ð ÉV cãġ Ácãġ cãġ Ácãġ Ácãġ Ácãġ cãġ { Ácãġ @ Ácãġ [| Ácãġ Ácãġ] á Ácãġ Ácãġ , } Ácãġ Ácãġ • cãġ } Ácãġ
 à | , ÉV | Ácãġ Ácãġ Ácãġ Ácãġ Ácãġ cãġ Ácãġ cãġ Ácãġ Ácãġ [| Ácãġ É
 JÉV ġ Ácãġ GÉV | Ácãġ | Ácãġ Ácãġ [| Ácãġ Ácãġ Ácãġ Ácãġ Ácãġ , Ácãġ ġ ġ [~ } Ácãġ Ácãġ Ácãġ É
 FÉV • cãġ Ácãġ cãġ @ Ácãġ cãġ [| Ácãġ ġ ġ , Ácãġ cãġ Ácãġ @ Ácãġ Ácãġ cãġ | Ácãġ ġ ġ , Ácãġ cãġ Ácãġ [cãġ Ácãġ] | É
 & cãġ ^ ÉV (ASM-JD-0052)

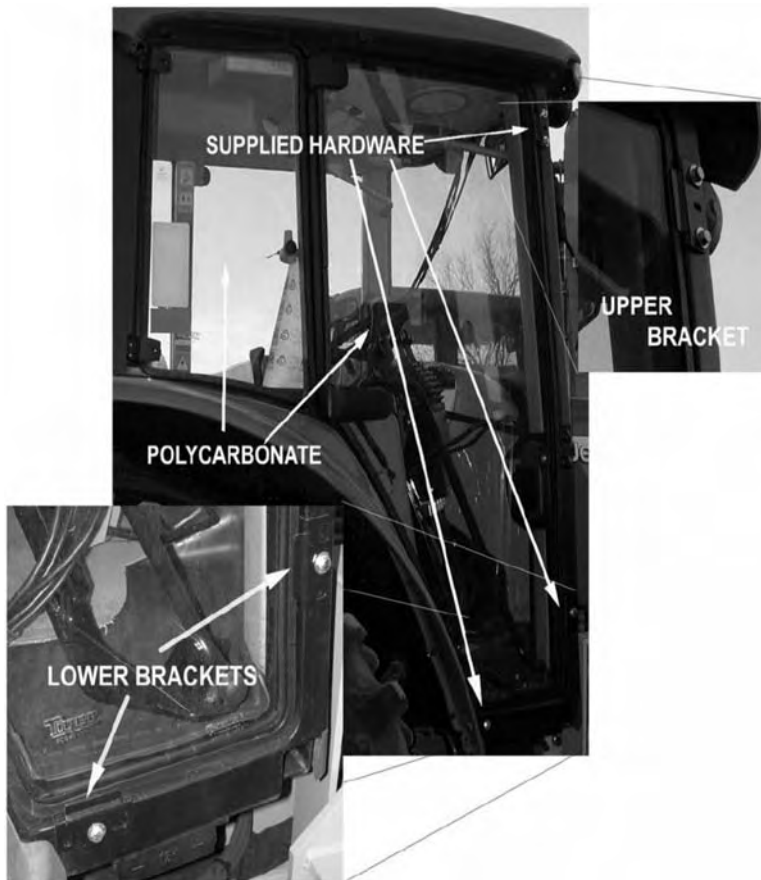

5 GG9 A 6 @M

G-89`A=FFCF`ACI BHB;

Öã•^ç à|^Á@Áã @Áã^Á à||Áãã^ÉÖ`óóÁ~ æ^Á| áãã áÁã^Á@. } ÁÁãç|^Á à^|, DÁÉFD+ÉÖE•^ç à|^Á@{ Áç* @@@ÉÁ[~} óóÁã @Á áÁã|Áãã^Áãã áÁããã, æ^Á|}Á||^Á|ã @Áç|}^Á|Áããç|ÁããÁã@, } ÁÁãç|^Áã||, ÉÜ^~Á|Á@ÁãóÁ^&ç} Éæç Á&^Á} ÉããÁ ç|^Á@Áãã, æ^Áã^çã ÉÁ (ASM-JD7220-0001)

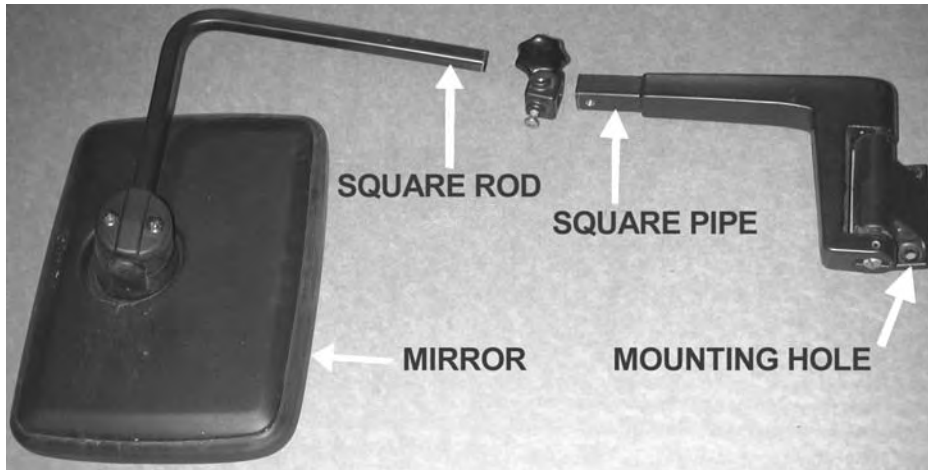

A5-B: F5 A 9`BGH5 @@HCB

Yãóã Áç|^@ãã@ãã áÁã|Áãã É çãã•Éãã^Á}^Áãã^Á-Á@Áãç^Á}Áç@Áç||^&ç^Á { æç@*Á[~}ç*Áç|^ÉÖE•ç|Áãç&^, •ÁããáÁã@Áããã, æ^ÁãÁ@, } ÁÁãç|^Áã ÁãóÁ^&ç}Áç^Á&|^Á@Áãã^Á-Á@Áã çããç^Áç@Áããç|Áããç*ÉÖÜÁUVÁã@}Áãã@Á çã^ÉÜ^~{[ç^Á@Áãç&^, •Á|^Áãããã^Áããã||^ÁãóÁãã||&ç*Áç^}ÉÜ^ã•^|óóÁ&ç&^, •Áããáã@}Áç|^~^Áçãç^~Á[ç^Áã@Áç|^~^&çóç|ÁãããÁã@Áãçç}ç&^Á^&ç}Á-Á@Áãç~çÉ (ASM-C-0003)



7 5 6 @ ' 7 C B H F C @ @ J 9 F ' G H 5 B 8

U } A @ & { } ! ^ I ^ S @ & A [• d i x a s A A [a s e f E H - A [{ A @ A a • @ I a s e a C G E F D - A [{ A @ A [I L A @ } A s o a H D + A s e e ^ c i A Q I A Q [~ * @ a @ A ^ c i A j e c e A @ I I E V @ A a I A Q [• ^ A a @ ^ a a A c ^ I A a [• • A e A a e a e @ a @ & { } d [I A [c A ~]] [i o a i a e A ^ e

V @ A ^ a s A [] ! ^ I ^ A o A S e a i ^ A [] d [I A c a a s A A j e s a A a e j] [c a e e I ^ A E F D - A [{ A o A a ^ A - A o A a e E V @ A [] } c A ^ a ^ A - A o A c a a s A A] A e e a e • o a @ & { } ! ^ I ^ S e a A [• o a a s o A a [I A a I A a A - A o A a e E N O ^ - I ^ A [^ A s e A i A a i A s e ^ A Q I ^ E A & @ & A e I A ~] [i o j e e • A I A s a • A] a i A o A a s B A o A S e a A H [[I E A U V O K O ~ c a * A d j A e e • A I A a • A e s a • A [I ^ A [I A A ^ c i A [] ^ A s e a s i j a s A s e a s * ^ I ~ • E N Y @) A [^ A] , A @ i ^ A o A a s a • E j e e • A a E A s e A] ^ A - A o A A [~ } c a * A Q I ^ E A O i a i A a I A D - A Q I A Q [~ * @ a @ A s e a a s o A [~ * @ a @ A [I A - A c o A S e a E A ^ c d A o a o A a s A] A e a A a s A o A A c o i A s [A Q I ^ o A [] A o A S e a A [[I E N O i a i A o A Q I ^ o A Q [~ * @ a @ A [[I E A T s e A o A A { a s e a a s i a i A o A A c o i A s [A H - A Q I ^ E V ^ A s e f A Q I A s e A a s a s o a s e f A Q I A Q [~ * @ a @ A s e A c i A a s o a H - A Q I ^ E A U ^ & ^ I ^ A o A c a a s A e A o A A [[I A a o a o A] s e I ^ E a e j • & ^ , • A e a A ^ [] & A ^ o A i [c a a a E

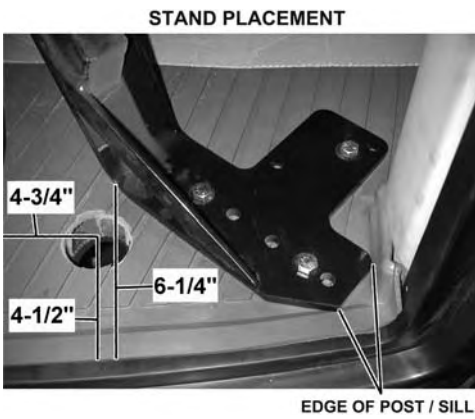

UNDER FLOOR OF CAB

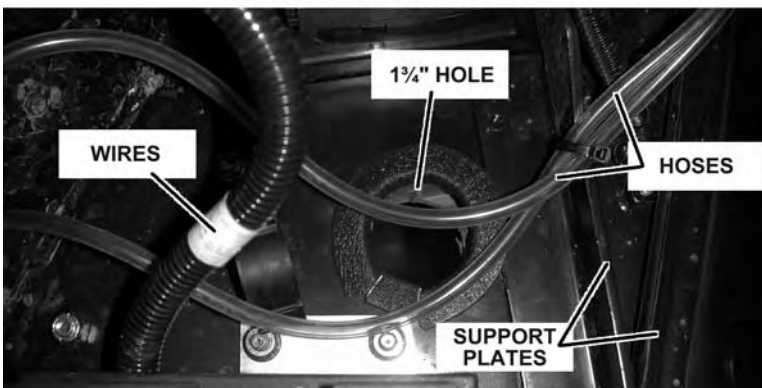

O ~ a s e f E H - A Q I A s A o A [[I A A [~ c A o A S e a i ^ A s e a A a ^ A o A [~ * @ E N Y ^ a • A i A c e s A s e f D - A & ^ a e a e & A e I A o A a a e A [& E N O ^ - I ^ A [^ A s e A i A a i A s e ^ A Q I ^ E A & @ & A e I A ~] [i o j e e • A I A s a • A ^ c i A [] ^ A s e a s i j a s A s e a s * ^ I ~ • E N Y [I A] a i A o A A [[I A ^ - I S e a i ^ A s e a a A j e e • A o A e A [^ A ^ a A e A s e j e E V @ A Q I A A • Q ~ j a s A s e] [c a e e I ^ A E F D - A [{ A o A A [[I A a I A e a s a s a I E H - A [{ A o A A a A - A o A a s A] a i A o A & { } • [I E N Y • c a i A o A d a A [& A e j ~ } a s o A A ^ c a A a ^ A - A o A A Q I ^ E A o A A [~ c A c o A & { } d [I S e a i ^ A s e a a s a s a ^ A o A [~ * @ a @ A Q I ^ E A



P U V O K O ~ c a * A d j A e e • A I A a • A e s a • A [I ^ A [I A e I A A ^ c i A [] ^ A s e a s i j a s A s e a s * ^ I ~ • E N Y [I A] a i A o A A [[I A ^ - I S e a i ^ A s e a a A j e e • A o A e A [^ A ^ a A e A s e j e E V @ A Q I A A • Q ~ j a s A s e] [c a e e I ^ A E F D - A [{ A o A A [[I A a I A e a s a s a I E H - A [{ A o A A a A - A o A a s A] a i A o A & { } • [I E N Y • c a i A o A d a A [& A e j ~ } a s o A A ^ c a A a ^ A - A o A A Q I ^ E A o A A [~ c A c o A & { } d [I S e a i ^ A s e a a s a s a ^ A o A [~ * @ a @ A Q I ^ E A

P ^ c d A [a s A o A S e a i ^ A s e a o a o A A +] j a Q I ^ o A s o A A [a c A c o A ^ A e e • A o A [~ * @ a @ A Q I ^ E A s a A & ^ I ^ A o A A e a E N Y] I A U V X A ^ a e I A s e a s e j ~ } a s a a e a s e s e a i ^ A s e a a A] j a Q I ^ o A E s e a s e a s e a a i o a e A A - A o A S e a A [A s A , a e i A a c o A a e E N Y • c a i A] ^ I A ~] [i o a i a e A ^ c i A [{ A s e a A [• o A s A o A & { } d [I A ^ c i A c a a e

(ASM-JD CBL MNT-0002)



5 GG9 A 6 @M

GK #H7 <6 CL 'K ≠B;

U[, ^!ÁÍ !Á@Á, æ&@ [cÁ Áæ&••^áÁ@ [* @Á@Á [!ÁÍ ææ^áÁ } Á@ÁÍ, ^!Áá @Á^æÁ Á@Á
 ææÉÖZ@ @ ÁÖ^!ÁÍ * ÁÁ^áÉ æó } { à!ÁÜÖÍ ÍÍ FÉÜUÁ UVÁ } } ^&@ÁÍ * ÁÍ Á@ÁæÁ
] [!Á } cÁ@Á áá * ÁÁ {] | Á@ÁÉV@Á á^ Á@ÁÍ * ÁÁÁÍ [!ÁÁÜÖÖÉÖÖÖÁ áÁÜÜÖÖÖÖÁ
 V@ÁÜÖÖÁ á^Á áÁ, æ•Á^Á@ cÁ [ÁÁ^á ÁÁÁ } ^áÉÖÖæ&@ } } ^&@ !ÁÍ H ÁÍ Á } áÁ-Á
 ÜÖÖÁ á^Á áÁ^Á á^ÁæÁ } ÁÁ-ÉV@ÁÖÖÖÁ áÁÜÜÖÖÖÖÁ á^ÁÁ@ cÁ @ } Áæ&@ !Á^Á
 áÁ } ^áÁ Á@ ÉÖ } } ^&@ÁÖÖÖÖÁ á^Á Á@ÁÍ * ÁÍ Á@ÁÖÖÖÖÁ á^ÁÍ { Á@Á, æ&@ [cÁÁ
 V@ } ÁÍ } } ^&@ÁÜÜÖÖÖÖÁ á^Á Á@ÁÍ * ÁÍ Á@ÁÜÖÖÁ á^ÁÍ { Á@Á, æ&@ [cÉ
 V@Á [ÁÜÜÖÖÖÁ á^Á ~ •ÁÁ } } ^&@ÁÁ Á@Á^ dæÁæcÁ á^ÁÁ cÁ * Á@Á^ dæÁ
 •æcÁ á^Á áÁ } } ^&@Á^ ÁÜÜÖÖÖÁ á^Á } } ^&@Á áÁ@Á @!ÁÜÜÖÖÖÁ á^Á Á@Á @!ÉÁ
 Ü^Á!Á Á@Á, æ&@ [cÁ&@ { æá } áÁ áá * Ááá } ÁÍ Ááá } } { | { æá } É
GH5B85F8 AC89 @G. Á^ dæÁæcÁ á^Á ÁÁÍ, } Á áÁÍ ææ^áÁ } á^ÁÁ^ * ÁÍ { } ÉÖÖ cÁ
 æá [cÁ Á@Á @Á á^Á ÁÍ { } ÁÍ Áæ&••ÉY ÖVÖPÁUWÁÍ !Á cÁ cÁ * Á á^É
DF9A A AC89 @G. Á^ dæÁæcÁ á^Á Á@ÁÍ ^ÁÍ é Í ÖÉÁ á^ÁÍ ææ^áÁ } á^ÁÁ @Á áÁ
 & } • [ÁÉÜ [cÁ á^Á } á^Á@ÁÍ } • [ÁÉ
 ÖÉ!ÁÍ } } ^&@ * Á@ÁÍ, ^!ÁÍ Á@Á, æ&@ [cÁÁ ~ cÁ@ÁæÁ^Á } * Á@ÁÍ [!ÁÍ Á@ÁÍ, ^!Á
 !á @ÁÍ } } ^!Á Á@Á^æÁÁ áá, ÉÁÜ æá^ cÁç^ } ÉÁ@ÁY PÖVÁWÚPÁ UVÁVÚÁ
 ÇÍ Í HÍ ÉFFÖÖÖÁ Á@Á^ÁFÖ%Á@ Á@ÁÍ } • [Á^ÉHÁ -Á@ÁÍ [!ÉÁÍ ~ Á æÁ á ÖÁ Á^ [cÁÁ@Á
 & } • [ÁÍ Á æÁ^!Á^ Á [cÁç^ cÁç^ Á á^ÁÉV@ÁæÁÁ ÁÁÁ@ * @Á@Á^ • ÖÁ [~] ÖÁ áÁ
 , !á Á@ { Á@ } áÁ@ÁæÁ^ÁÍ { Á@Á, æ&@ [cÁ Á@Á áá, ÉÁ ÖÖÖÁWÜÖÁ@ÁæÁ^Á
 æá • æá^ÉÖÖÖÁ UVÁ ÖPÖÖÖÖÖÖ cÁ { æÁ@ Á@Á [cÁ Á@Á áá, ÉÁÜPÖÖÖÖÖÖÁ } [* @Á
 cÁ ÁÍ, Á@ÁæÁ^Á@ * ÉÁÜ || Á@ÁæÁ^Á@ * @Á@Á@ Á } cÁ@Á^!Á ÁÁ [!ÁÁ [cÁç^] cÁ ÁÁÁ
 Á^Á@ÁæÁÉÁ !á Á@ÁæÁ^Á áÁÜ | áÁ^ ÁÁ^ cÁ@Á * @Á@Á@ ÁÉÁ æÁ^!Á@ÁæÁ^Á
 áÁá @ÁÍ [^ÁÍ { Á@Á, æ&@ [cÁ Á@Áá cÁ áÁÉV@Á @ } Á@Á áÁ áÁ { [cÁÁ@Á c&••Á
 cÁ ÉÖ] cÁ ^Á áÁ@Á @!Á [ÉÁ [cÁ * ÁÁÁÁÍ { Á@ÁæÁ^ÁÁ^ Á [cÁÁ, æáÁ@ÁæÁ Á-Á
 @ÁæÁÉÁÜ || ÁÁ^ Á cÁæÁ^Á@ * @Á@Á@ ÁÉÁæá * Á [^ÁÁÁ áÁ^!Á } áÁ@Á^Á áÁ
 cÁ^É

U [cÁ@ÁÖá } • ÁÍ } } ^&@ !ÁÍ Á@ÁÍ * Á } Á@Áçç^ÉÁÜ [cÁ@ÁÁÍ !á * ÁÉÁÁÁ ÉÁ
 , @ÁÁ á^Á Á@ÁÍ [cÁ Á@Áæ&@ ÁÁ } * Á áÁ@Á@ • • ÉÖÖ } } ^&@ áÁ áÁ-ÉV@ÁÍ !á * ÁÁ
 , á^Á áÁ } ^Á Á@ÁÁÁ Á á^Á [^ÁÁÁ Á Á@ÁÁÁÍ & Á } Á@ÁÖá } • Áçç^ÉÁÜ@Á @Á áÁ
 áÁÁ Á á^Á [^Á Á@ÁÁá^Áçç^Á } Á@Á áá } ^á ÉÖÖÖÁ @Á Á áÁ@Á, æ&@ [cÁ&@ { æá } Á
 ááá } } { | { æá } É (ASM-JD-0008)



JOHN DEERE PLUG

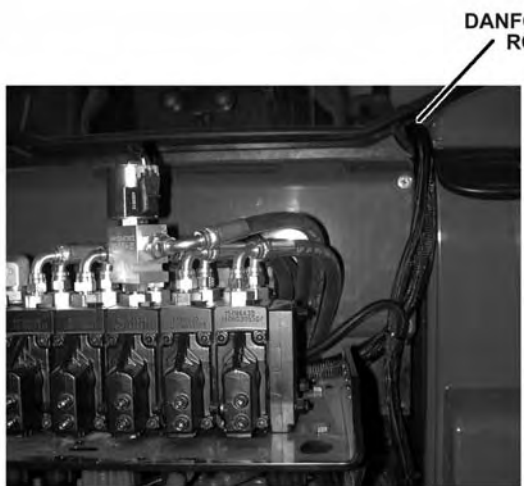

DANFOSS CABLE ROUTING



5 GG9 A 6 @M

>CMGH7 ? 'GK #H7 < '6 CL 'ACI BH#B;

Š [&ae^ Á@ ÁGÁ [^ Á@ Áa @Á [] oš [] ^ Á Á@ Áa Áaš ^ ÉWV @ Á Á [^] q̄ * Á @ Á Á@ ÁGÁ [^] q̄ * Á [| o Á Á@ Á, š@ @ [c Á aš ^ ÉWV ^ Á šc | ^ Á Á [, ÉWV [^] oš @ Á aš ^ oÁ * q̄ * Á @ Á@ a, aš ^ Á]] a á Éa Á [c á š Á @ Á aš o Á ^ š q̄] É (ASM-JD7000-0001)

CORNER MOUNTING BOLTS



SWITCH BOX MOUNTING BOLTS

=JH'>CMGH7 ? 'ACI BH#B; 'fGK #H7 < '6 CLŁ

Q • cš Á @ Á ^ • cš Á [^] q̄ * Á aš ^ oÁ Á @ Á aš Á Á@ Á, š@ @ [c Á aš ^ ÉWV ^ Á @ Á aš ^ š q̄ Á @ Á aš o Á ^ š q̄] š q̄ Á @ Á šc | ^ Á Á [, Á Á aš ^ { a | ^ Á @ Á ^ • cš Á aš ^ { a | Á Á @ Á Á VE Á Ee^ Á @ Á ^ • cš Á Á aš ^ Á [^] c á Á aš aš aš • q ^ } oš q̄ Á aš ^ aš aš ^ Á Á Á @ Á [a Á] Á @ Á [^] q̄ * Á aš ^ oÁ BchYH Ya ci bh [W a dcbYbg'a i ghVY^cWUNX'gc'bc hlc 'j b h f Z f Y f' k] h ' c h Y f W b h f c g ' Á Á [^] c á @ Á ^ • cš Á aš ^ Á Á [{ Á @ Á } d [| Á [c Á Á @ Á ^ • cš Á ÉWV ^ Á ^ Á Á Á Á Á] * @ Á aš Á Á @ Á aš ^ Á Á [, Á Á [c Á ^ } oÁ Á @ Á ^ • cš Á ÉWV ^ Á ^ Á @ Á aš ^ Á @ Á { [^] q̄ * Á aš ^ oÁ š@ @ Á Á aš ^ ÉWV ^ Á Á cš Á aš] ÉWV ^ Á @ Á aš ^ Á Á [{ Á @ Á, š@ @ [c Á Á @ Á aš oÁ cš ^ Á @ Á] * @ Á aš Á aš ^ Á @ Á aš Á q̄ aš , ÉWV [c Á Á aš] aš aš aš Á aš ^ Á Á aš aš ^ Á aš aš & aš] • Á aš ^ Á aš ^ • aš ÉWV (ASM-JD IVT SWITCHBX-0001)

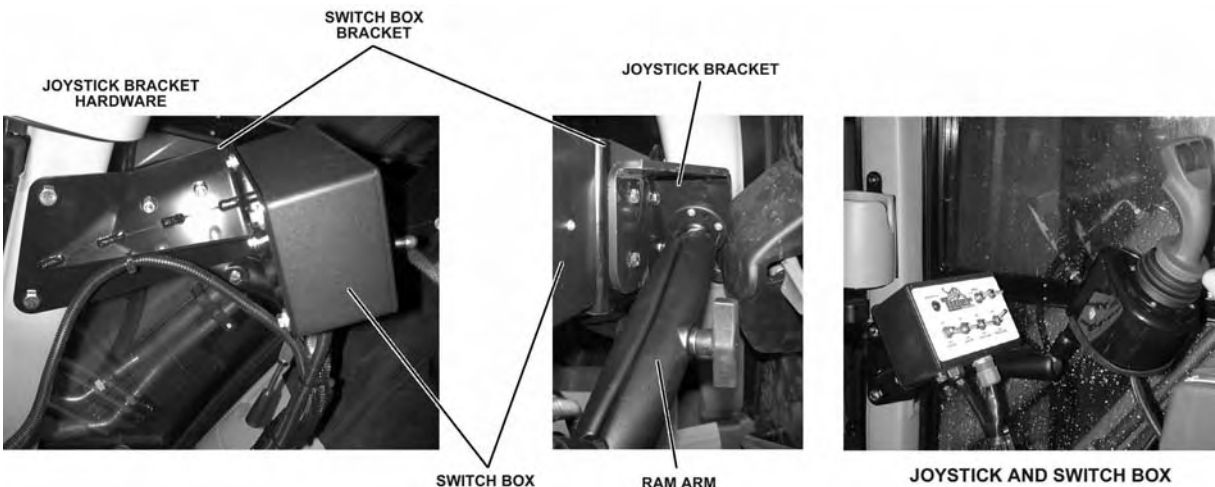

5 GG9 A 6 @M

≡H'>CMGH7 ? 'A CI BH-B; 'fG95H'ACI BH-L

Úææþ|Á@Áá^Á-Á@ÁVÁ^•æÁ [] ÖÁ Á@Áá^Á-Á@ÁæÁæ Áæ áÁ æÁ Á@Á@|Á•Á
 { |Á|á|á * ÉÁ:á|á áÁæ Á [ÁD+ÁQ|Á•Á@|~ * @Á@ÁæÁ|æÁ á@ÁÁ ÉÁ:á|á|áææ@ ^} ÉÁ:á|á
 [] |Á@|~ * @Á@ÁæÁ|æÁ [Á@|~ * @Á@~@ * Á|•É

Öææ@Á@ÁVÁ^•æÁ [] ÖÁ Á@ÁæÁ|æÁ á@ÁD+Áæ•&^, •Ç@æáÁ ÉÁ|&|Á@Á
 { [] Á á@Á@Á| &, æ @|•Áæ á@Á@Á~Á| [ÇæáÉ

Y^á^Á@Áæ áÁ~Áæ áÁ} [áÁ} Ç Á@Á^@&^, Áæ á@ÁæÁæÁæ Ç Á@ÁæÁ-Á@Á^•æÁ
 { [] ÉÁQ^!Á@Á^ [] Á•@ * Áæ á@Á@Á| { ^áÁ| áÁ Ç Á@Á-áÁ-Á@Á^•æÁ [] ÖÁ áÁ
 ç@} Á@Á} [áÉ^&|á * Á@Á| { ^áÁ| áÉ

Q^!Á@Á^ [] Á•@ * Á| Á@Á^•æÁ Áæ Ç Á@Á-áÉÁ ^á^Á@Áæ áÁ~Áæ áÁ} [áÁ
 [] Ç Á@Á^@&^, Áæ á@ÁæÁæÁæ Ç Á@ÁæÁ-Á@Áæ ÉÁ|æÁ Á@ÁæÁ} Á@Á| { ^áÁ| áÁæ áÁ
 ç@} Á@Á^@&^, Áæ áÁ} [áÉÖææ@Á@Á^•æÁ Á@ÁæÁ á@Á@Á^@&^, •Á| [ÇæáÉ

BCH9. 5 X1 ghH Y'cmgh|W'gc'H Y'Wca dcbYb|g'Xc'bch|bhYfZYf'k|H'H Y'ch Yf'Wb|fc'g"Á

Ü|~ ÇÁ@Á^•æÁ Áæ|Á Á@Á| [|Á-Á@ÁæÁ-Á@Áæ@Á} •|ÁÉÁ@} Á| { Á@Á|} •|ÁÁ Á
 @Á, áæ@Á| ÇÉÁ^!Á^!ÁÁæ^Á} [~ * @|æÁ Á@ÁæÁ|Áæ|, Á|Á [Ç{ ^} ÖÁ Á@Á^•æÁ ÉÁ
 Ú^ÁÁ, áæ@Á| ÇÁ áá * Á|Á { |æ} Á} Á^&|á * Áæ|Á-Á| Á@Á|} •|ÁÉ

(ASM-JD IVT JYSTK SEAT MNT-0001)

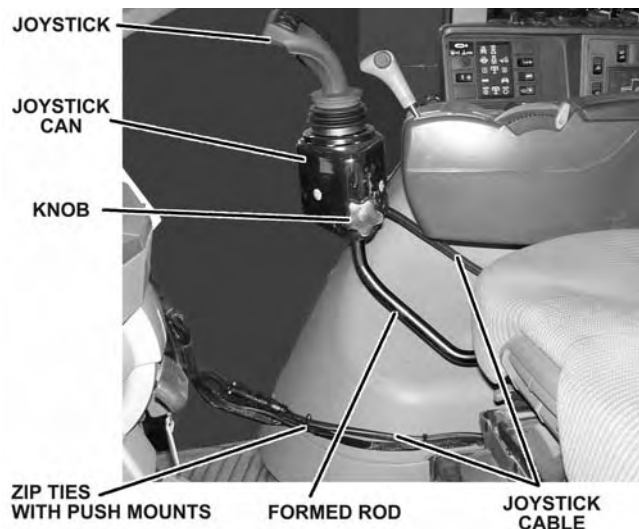
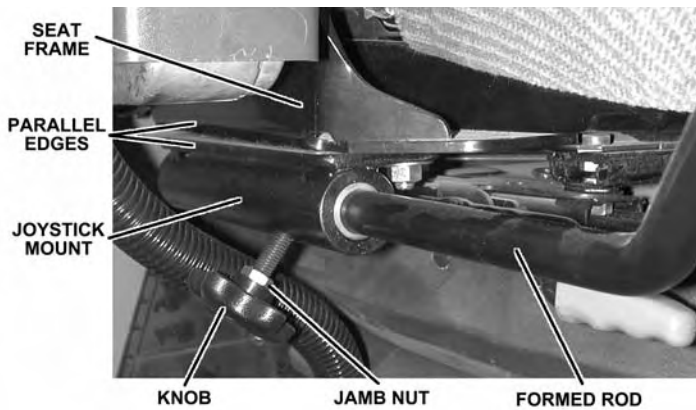

5 GG9 A 6 @M

DF9A≠ A`5 FAF9GH>CMGH7 ?`ACI BH≠B;

K #k `5 F`F`89`G95HI D; F589

Ü^ { [ç^Á@ÁE { !^•dÄ

Ú|æ^Á@Á^•cæÁ [~ } ç * Á!æ^Á } Á@Á { !^•dÄ^Á@Á!æ^Á } |^•Á Á æ Á@Á@^Á
@|^•Á Á!á|Á@ [~ * @Á@Á { !^•dÄ^ { [ç^Á@Á { !^•cæ áÁ!á|Á@^Á Á@|^•Á@ [~ * @Á@Á •cæ^Á
[-Á@Á { !^•dÄÁ!á áÁ -Á|^•Á@ [~ * @Á@Á •cæ^Á Á -Á|æ cæÁ!Á@Á æ@^Á&^, •Á Á [Á
@ [~ * @

Ú|æ^Á@Á^•cæÁ [~ } ç * Á!æ^Á } Á@Á { !^•c [Á@Á } c!Á } [àÁæ Á ç Á@Á|^Á áÁ@Á|^•Á
~] Á^ç ^Á } Á@Á [~ } ç * áÁ@Á { !^•dÄ^Á@Á!æ^Á } æ@^Á&^, •Á Á^&!^Á@Á^•cæÁ
{ [~ } ç * Á@Á { !^•dÄ

U } &^Á@Á |á!Á ç •cæ^Á } Á@Á { !^•dÄ } |æ^Á@Á { !^•dÄ (ASM-JD PRM JYSTK ARMST-0001)

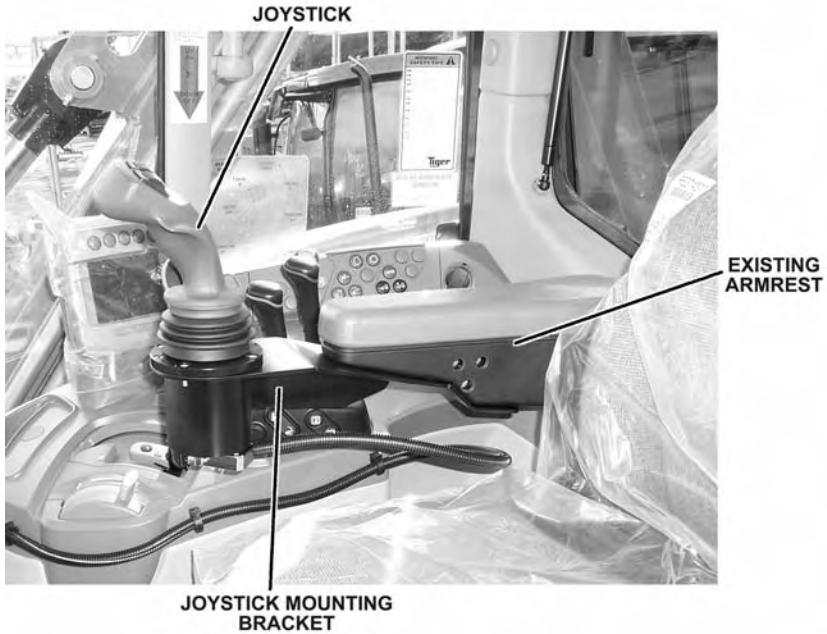

5 GG9 A 6 @M

< M8 F 5 I @7 ' DCF HG fDF9A4 AL

V@•^Á [!o Áe^Á [&æ^áÁ } á^!Á@ Áe&ç !Á^æÁ^ [(c•Áe) áÁe^Á [&æ^áÁe Á @, } Áe Á@Á
ã æ^Á^ [, ÉÁÚ^Á Áe Á@Áe Á^&ç } Áe Áeááã } æÁe { !{ æç } É
(ASM-JD60-7030-0002)

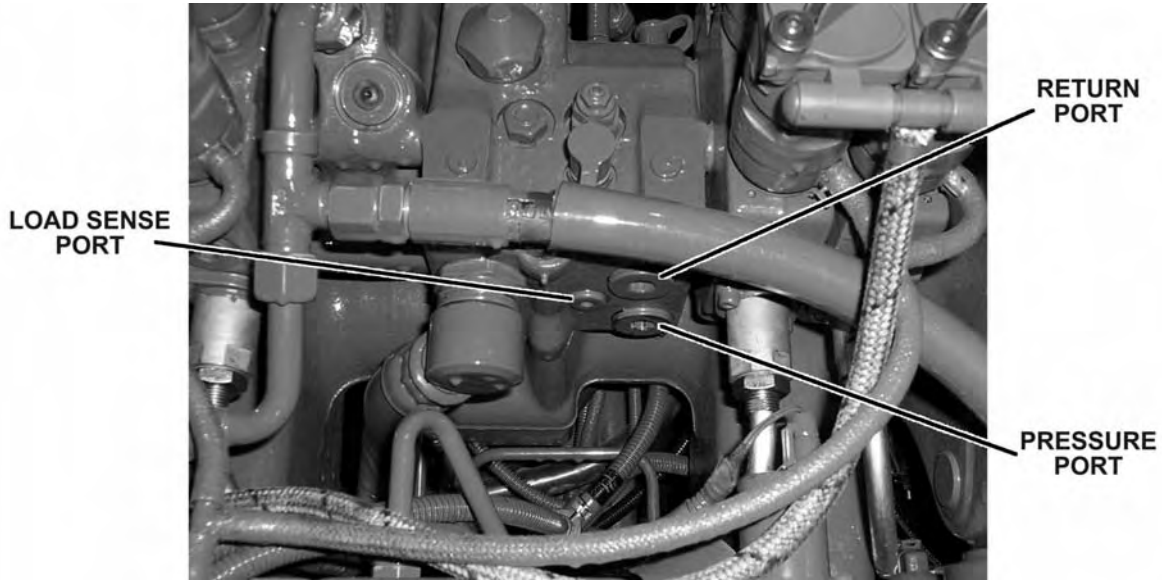

< M8 F 5 I @7 ' DCF HG fGH5 B8 5 F 8 L

V@•^Á [!o Áe^Á [&æ^áÁe Á@Áe Á^ Á@Áe&ç !ÉÁ } á^!Á@ Áe&ç^ÉÁ @!^Á@ Áe&ç^Á [~ } É
á * Áe Áe^ Áe&ç^ Áe Á@Áe&ç !ÉÁV@Á æáÁ^ •^Á [!Áe Á } Áe] ÉÁ@ } Á@Á!••!^Áe áÁe æÁ^ Á
c@Á^c !} Á [!Áe Á @, } Áe Á@Áe æ^Á^ [, ÉÁÚ^Á Áe Á@Áe Á^&ç } Áe Áeááã } æÁe { !{ æÉ
ç } ÉÁ (ASM-JD60-7030-0004)

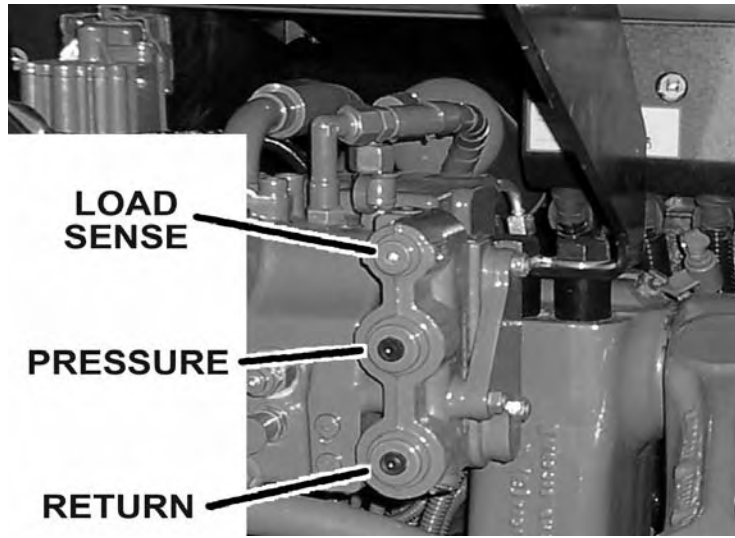

5 GG9 A 6 @M

<M8 F5I @7' @B9'D@ A6-B; .

DF9 GGI F9' @B9'-BGH5 @@5HCB

V@Á@a|æ|æÁ|·~|^Áq^Á q|Á^Á| { à^áq ç Á@Á^æÁ Á@Á^æq |Á^ { [ç^áç^ÉÁŠ |æ^Á @Á|^·~|^Á| |ç| } Á@Á^æÁ^ { [ç·Áq áÁ^ { [ç^Á@Á| * Á^Á|Á Á@Á^á|æ|æÁ| |çÁ |çÁ q|·dæq } Áq áÁ@ÁÚæ·Á^&ç } Áæ^·Á|Á|·q } Á Á@Á|^·~|^Á| |çÁ|Á@Á| * Á Á |^ { [ç^á@ } Á·ç|Á| { { Áqç ç|Á|Á| } } ^&ÁFÁ@·Á| { Á@Á^æq |Á^ { [ç^áç^Á Á @Á^á^|çç^É (ASM-27mmPRESSURE-0001)

F9HI FB' @B9'-BGH5 @@5HCB

V@Á^ç| } Áq^Á q|Á^Á| { ^á^çç Á@Á|^·~|^Áq^Á } Á@Á^æq |Á^ { [ç^áç^ÉÁŠ |æ^Á @Á|^ç| } Á| |çÁ| áÁ^ { [ç^Á@Á| * Á^Á|Á Á@Á^á|æ|æÁ| |çÁ| |çÁ|·dæq } Áq áÁ@ÁÚæ·Á^&ç } Á ç|Á@Á|·q } Á Á@Á^ç| } Á| |çÁ|Á@Á| * Á Á^ { [ç^á@ } Á·ç|Á| { { Áqç ç|Á|Á| } , ÉÁ P^çç } } ^&ÁFÁ@·Á| { Á@Á^æq |Á^ { [ç^áç^Á Á@Á^á^|çç^É (ASM-27mmRETURN-0001)

@C58'G9BG9' @B9'-BGH5 @@5HCB

V@Á| çá^·~|^Áq^Á q|Á^Á| { à^áq ç Á@Á|ç| { Á Á@Á^æq |Á^ { [ç^áç^Á^Á|Á Á@Á P^á|æ|æÁ| |çÁ| |çÁ|·dæq } Áq áÁ@ÁÚæ·Á^&ç } Áæ^·Á|Á|·q } Á Á@Á| çá^·~|^Á| |çÁ| Š |æ^Á@Á| * Á } Á@Á^æq |Á^æÁ^ { [ç·Á|Á@Á| çá^·~|^Áq^Á } Áq áÁ^ { [ç^Á@Á| * ÉÁ·ç|Á Á FI { { Áqç ç|Á|Á| } , Áq áÁ^ } ÁFÁ@·Á| { Á@Á^ { [ç·Á|Á@Á^á^|çç^ÉÁ^Á|Á Á@Á Úæ·Á^&ç } Áæ^·Á|Á|Á| | à^áq ç Á Á@Á^æq |Á^ { [ç^áç^Á@| } É (ASM-14mmLOAD SENSE-0001)

9 @7 HF CB=7' @ H'J5 @9'DCFHG

(ASM-C-0089)Á

DANFOSS VALVE

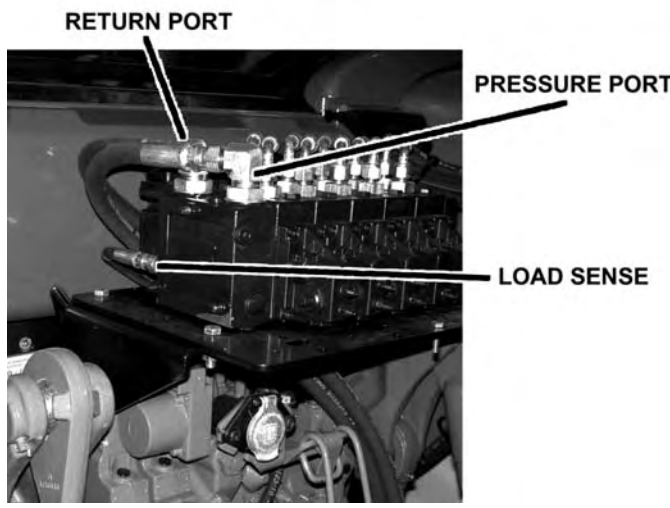

5 GG9 A 6 @M

A5 BI 5 @@ H'J5 @9 'DCFHG

Á

LOAD SENSE

RETURN PORT

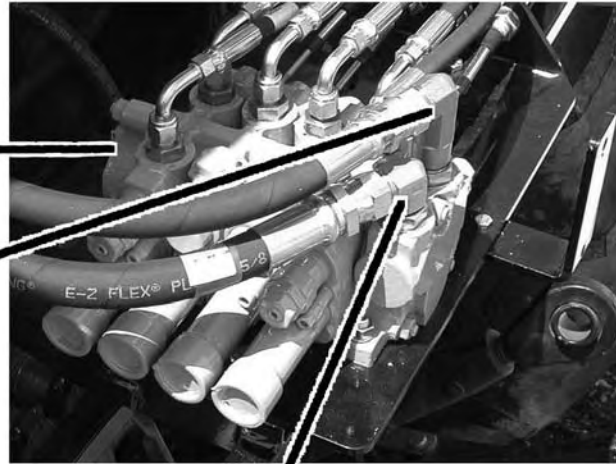

PRESSURE PORT

(ASM-C-0057)



5 GG9 A 6 @M

G9 @7 HCF`J5 @9`BGF5 @@5 HCB`

BCH9.Ü^~!Ä Ä@ÁÚæÜ^&ç}Äè àÄ|~•dæä}Ä^||, Ä|Äæä, æ^Äè àÄ|•æä}É
V@Ä^|^&ç|Äçç^Ä Äææ&@äÄ Ä@Ä[[{ Ä•dÄV@ÄFD+ÄQ•^•Ä|{ Ä@Ä, ä^|^|^&ç}Ä Ä@Ä
|äççç^Äè^Ä|{ ä^äÄ Ä@ÄGÄè äÄGÄ|{|Ä Ä@Ä^|^&ç|Äçç^ÄGÄ}Ä^Ä ÄæäàäÄ Ä@Ä
|^c|}Ä^&ç}Ä Ä@Ääççç^ÄGÄæ&@ÄÄFD+ÄQ•^•Ä|{ Ä@ÄVÄ|{|Ä Ä@Ä^|^&ç|Äçç^Ä Ä@Ä
|^}Ä^Ä}Ä@Ääççç^ÄFD+ÄQ•^•Äææ&@äÄ Ä@ÄGÄ+ÄGÄGÄ+ÄGÄGÄ|{|Ä}Ä@Ä
•^|^&ç|Äçç^Ä Ä@Ä} &|^Ä&|ä ä^Äè äÄ, ä^|^&ç|Äè^Ä(ASM-SLCTR VLV INSTLN-0001)

FROM SWIVEL SECTION
ON LIFT VALVE RETURN TO VALVE

GLAND
KNUCKLE
CYLINDER
BUTT
BUTT
SWIVEL
CYLINDER
GLAND

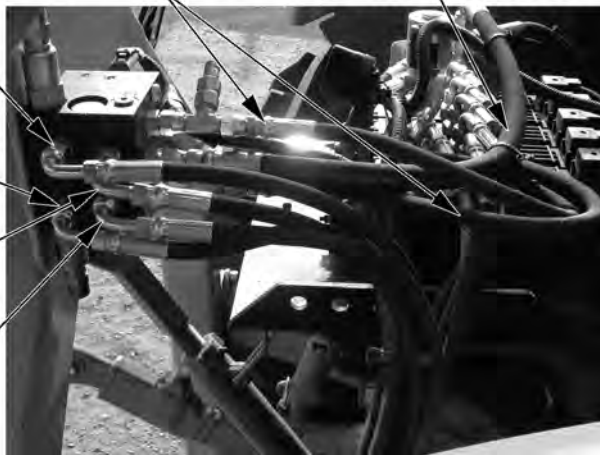

5 GG9 A 6 @M

F95 F`GHCK`69B; 5 @<CG9`FCI HB;

K5FB-B; BCH9.ÁV@Á·áá^}Á!^æ^Á-@áæ|æ Á|!··!^Á&|~!á&æ·^Á@Á~ áá^}
 { [ç^ ^} of Á^!^Á@æ Áæo ÉÁO [^}^Á@Á æÁ-@·^Áæo&|~!á&æ·^Á@Á~ áá^}
 ÓUÁUVÁSSUY Á@·^Á@áæ|æÁQ·^Á Á ÓUÓCSÁ:ÁÓWÜUVÁ Á!á!Á Á!^ç^} @@áæ|æÁæ!^
 Tæ^Á~!^Á@ÁQ·^ÁÁ[Á] of á&@Á!Ád^&@Á Á[[Á [ç·ÉÁ^æ~!^ÁVY ÓÓ&@&ÁVY ÓÓ
 @}Á!| &^áÁ æO&æ ç}É

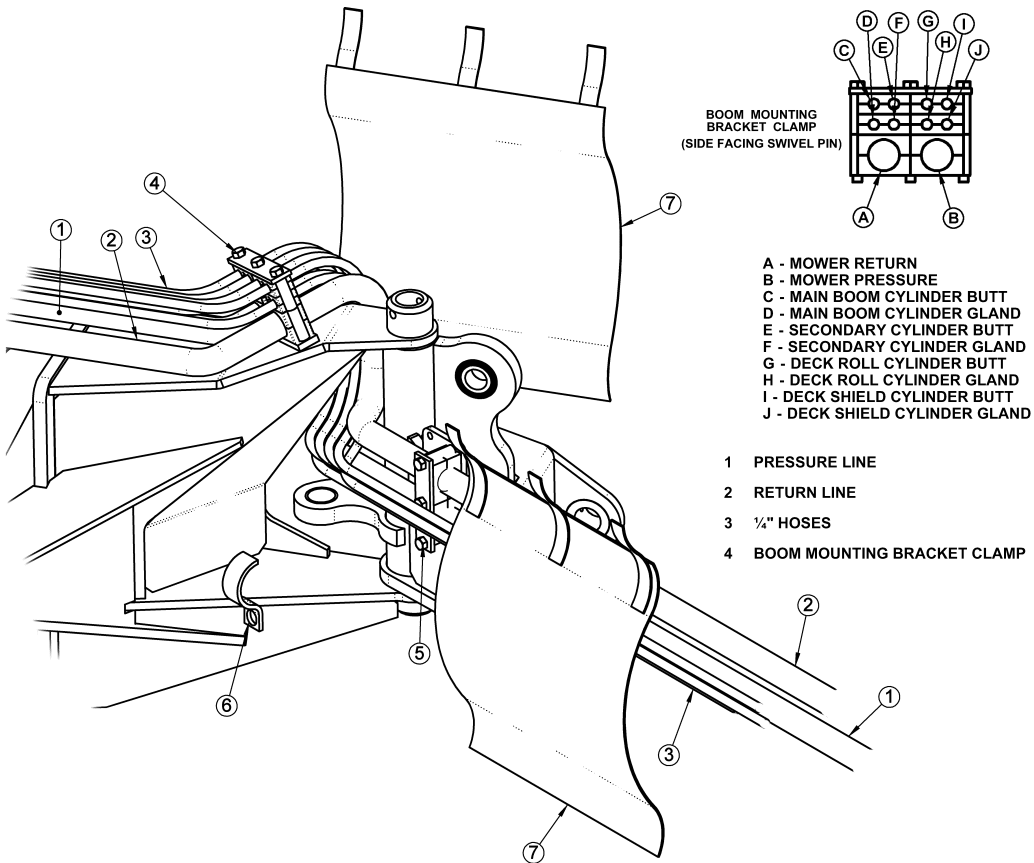

T æ\ Á@ Á^+Á^ç } ÁQ·^Á Á ÁHÁBÁ!+Á[{ Á@Á} áÁ@Á á!&| } ^&@Á Á@Á!^!{ ^á&æ·^Á@Á
 V@·^Á æ·Á á!Á^Á!æááÁ@ÁQ·^Á&æ]·ÉÁV@ Á^+Á!··!^ÁQ·^Á@~!á&æ·^Á@Á~ áá^} Á!|
 @Á^ç!} ÁQ·^ÁÉÁU[~ Á@ÁQ·^Á@~ * @Á@Á] æÁ^Á^ç ^} Á@Á, æ^!Áæ áÁ@Á[[{ Á [~ } ç*
 á!æ^ÉÁO[] ^&@ÁQ·^Á Á@Á!^!{ ^á&æ·^Á@Á} áÁ [ç^Á@Á[[{ Á@Á Á! Á@Á, Á^ÁÁ[{
 ~!Á!|, æáÉÁO·^} à^Á@Á, æ^!Á&æ] Áæ áÁ!æ Á@Á^ç!} ÁQ·^Á!Á@Á [ç!Á} Á!] Áæ áÁ@
]!··!^ÁÁ^Á} Á@Á[ç{ ÉÁU]æÁ@Á+ÁQ·^Á Á@ÁQ·^Á&æ] Áæ áÁááÁÁ Á@Á[ç{ Á&^,
 [Á@Á, æ^!Á&æ] ÉÁ^çÁ æ\^Á~!^Á@Á!^ÁÁ[~ * @Á]æ Á! Á@ÁQ·^Á Á æ! Á@Á@Á á c
 , @!^Á@Á æ Á[[{ Á@Á Á!} á·Á@Á, æ^!Á@ÁQ, } Á@Á Á ^çÁ æ^Á@Á áÁ@Á } Á@
 Q·^Á Á@Á&æ] ÉÁASM-30S, 3PS HOSE ROUTING-0001A)



5 GG9 A 6 @M

F95 F`GHCK `69B; 5 @<CG9`FCI H-B; `f7 CBHL

BEFORE TIGHTENING
HOSES IN CLAMP,
MAKE SURE HOSES
CAN PASS THROUGH
CENTER POINT OF
BOOM PIN. THIS WILL
ENSURE PROPER
HOSE LENGTH FOR
ALL BOOM POSITIONS.

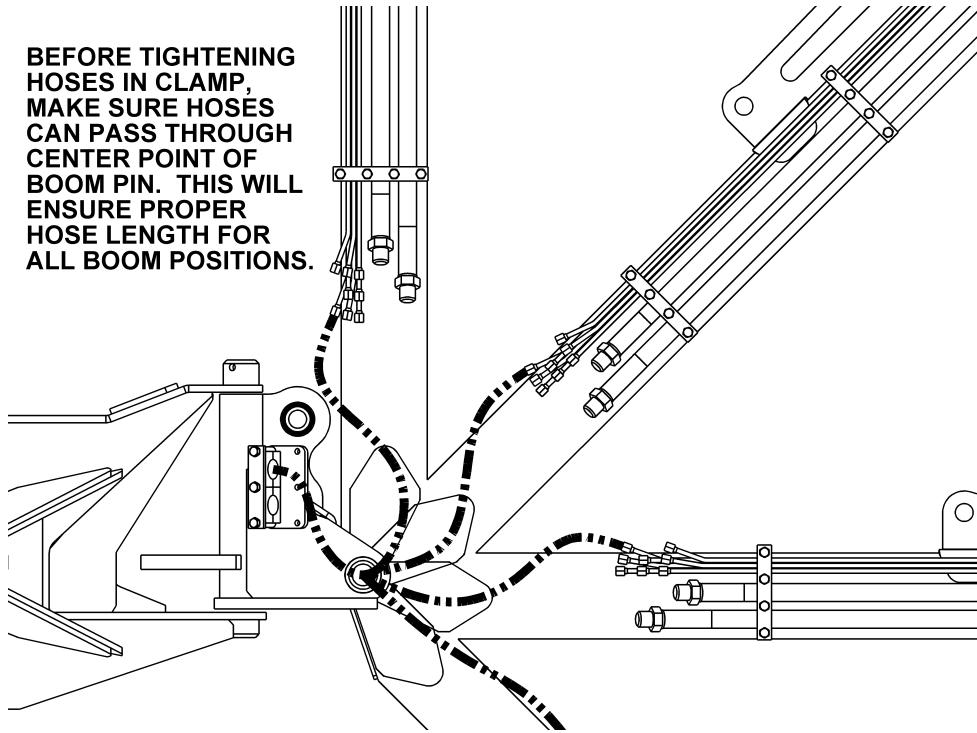

CE!aǝ *^A@AQ. ^•A A@&|ǝ] A@A@A@•A A@A[[{ A [˘} cǝ *A!ǝA^A@A@, } Aa[c^E
, a@A@A@A [d!AQ. ^•A| .^•A A@A!ǝA^A@A@A^c! } AQ. ^•A| .^•A A@A[[{ A@{ EAU ||
c@AQ. ^•A } *A![[A@A, a^A A@A [˘} cǝ *A!ǝA^A@A@] Eǝ @} A aǝ A[[{ A A c|A! , aǝE
ǝǝ aAǝ @˘} A@AQ. ^•A A@&|ǝ] E

T aǝ^A˘!^A@A@A@A [d!AQ. ^•A| A [A cǝ A A@A [[{ A@{ A A A [c^a Aǝ d A@A d , a *
][•aǝ } EYGA@A@] ^} •A@A [d!AQ. ^•A } A@A^A A A A @!c} ^aE^A&ǝ ^A@!^A A [A˘ &@
@. ^A A cǝ ^A } A|ǝ] E(ASM-30S, 3PS HOSE ROUTING-0001B)

5771 AI @HCF`BGF5 @@HCB

Q. cǝA@A&& { ˘|ǝ! A!ǝA^A@A } A@Aǝ @A aǝ Aǝ ^A a d! A a cǝ A [˘} dǝAǝ] | aǝA^Eǝ
, a@A@A@A &^, Eǝ| &, a @!•Aǝ aǝA] aǝ!•EǝAǝ] | aǝA^Eǝ A @, } A A@A@A@A^&cǝ } EǝA
Q. cǝA@A&& { ˘|ǝ! A A@A!ǝA^A@A aǝA^& :!^A a@A@A@A, a^A @, } EǝQ. cǝA@A@A *•Aǝ aǝA
@. ^•A A@&|ǝ] aǝ! A aǝ A|ǝ } d[| A cǝ A A A @, } A A@A@A@A^&cǝ } EǝA gYHZcb`HdYcb`U`
d]dY ZH]b[g fM WdhC!f]b[gL^A(ASM-C-0012)



5 GG9 A 6 @M

(ASM-C-0094)

REAR STOW BOOM HYDRAULIC DIAGRAM

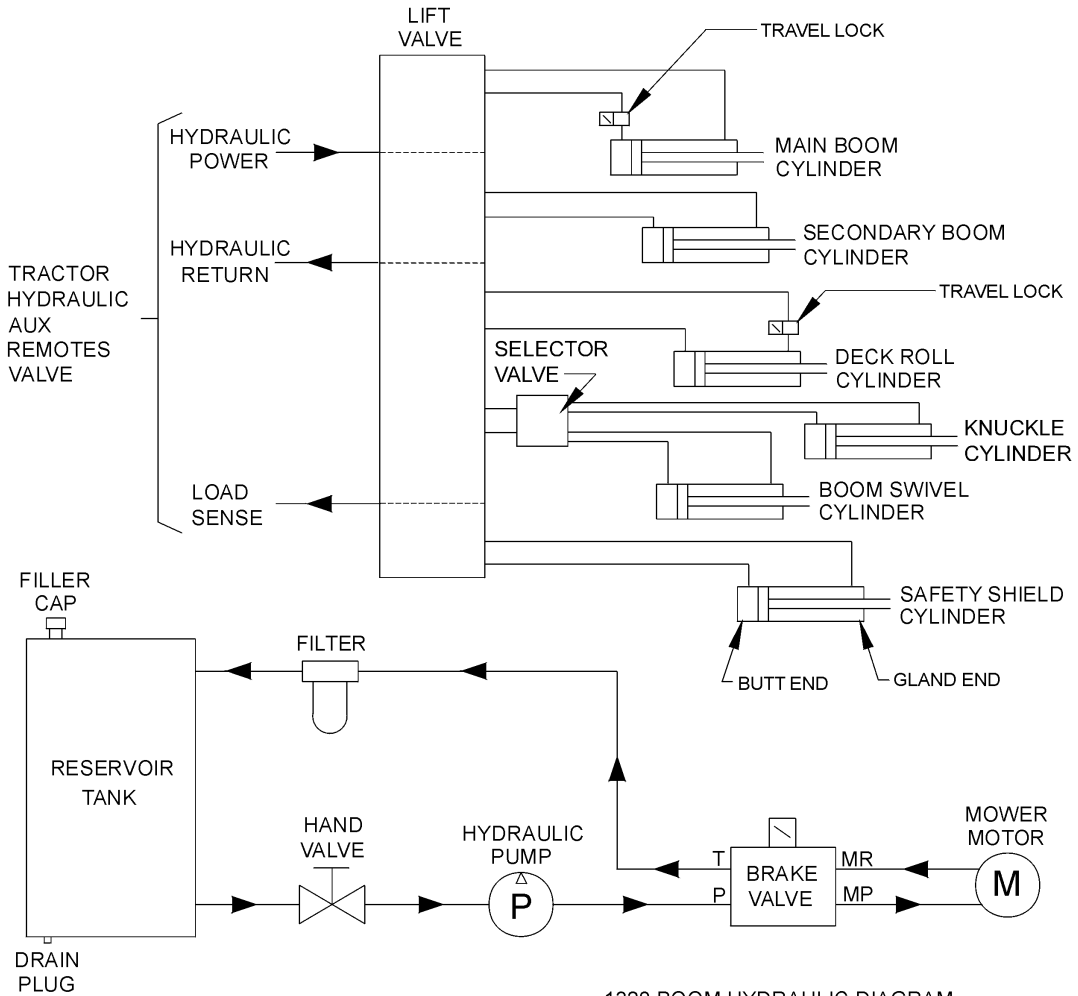

: =@@B; ` < M8 F5I @7` F9 G9 F J C = F

Ü^~!Á Á@Á æ c} æ & Á^&á } Á |Á|á * Á] ^&áá } • Á @á:æ |á| á^~ á{ ^} • È

BCH9. GHUhb[`cf'fi bb]b[`nci f'H][Yf' a ck Yf' VYZfY Z`]b[`fYgYfj c]f'k]`WU gY gYf]ci g'XuU U` Y'lc \ nXfU `]Wdi a d"

(ASM-C-0004hydro resrv)

; 9B9F5 @ < CG9` =BGH5 @@5HCB

Ü^~!Á Á@Á æ c} æ & Á^&á } Á |Á|á * Á] ^&áá } • Á @á:æ |á| á^~ á{ ^} • È

(ASM-C-0011)



5 GG9 A 6 @M

K < 99 @K 9 = < H' A C I B H B ;

Q | A s H A [, ^ | . A . a * A s A [[{ A [, ^ | E s A @ ^ | A ^ a @ A a | A ^ A ~ a ^ a A | A @ A ^ A s A @ ^ | E A Q , a | A ^ A ^ & ^ . . s ^ A A [~ } o A @ A H E E A [~ } a A @ ^ | A ^ a @ A a | A ^ A @ ^ | A . a * A @ A [} * A s a . & ^ . . E [[& , s e | . E A s s e @ | . E A s a A @ C A ~ o A ^ | A s s | s A s @ A U s o A U ^ & c A } E

Q . c a | s s a } A A [. o A s a A s [} ^ A s o A s { a | A | \ A s c A . ^ | c a * A s A | \ A s A @ A s } c | A [c A A o @ ^ | A ^ a @ A A V @ A @ s A A o A A s a . & ^ . . A s A A s A A s , s a A o @ A U W U O O A A A o A A ^ a @ A s o + s s s e @ | . A } A s | o A s . s e A s a A ~ o s e A A A o A s e . ^ { a | E

V @ A ^ A s A s A A ~ . o s [A A A a | a A s o A s a c | A A A s e | A s a A s a s a { A s Q | s e A s e a | ~ o A ^ [[~ } a A ^ | A s a | } E A v a A s A | ^ . . ^ | A Q | a A A A s s s a A s s | a s * A A o A A s s c } s e A U ^ & c A } E (ASM-B-0002)

FG'5 L @ '6 F 5 7 9 ' A C I B H B ;

A V @ A ^ s A s a Q , A s e | A s | s e ^ A s A A A s A A [~ } c a A } a ^ | A o A ^ s A s e | A A o A A s s Q | E A V @ A c @ | ^ } a A A o A s e | A s | s e A A [~ } o A } A o A A ~ o s e A A o A A , ^ | A ^ s A s | } ^ | . A A o A A s s ^ s e ^ E A C E e | s e s e Q * A o A s [[{ A . c A A Q | a A A A o | A s a A ^ c | A } a ^ | A o A A s s | E A C e s o A o A s e | A s | s e A Q D A c @ A s s A s a A s o A s a , s e A A Q , } A s A o A U s o A U ^ & c A } A s a A s a c } E A C e s o A o A s e | A s | s e ^ A s c @ A ^ s A s e | A A . a * A o A A [~ } c a * A s a , s e A A Q , } A s A o A A s o A ^ & c A } E A o O U A U V A s c } E A

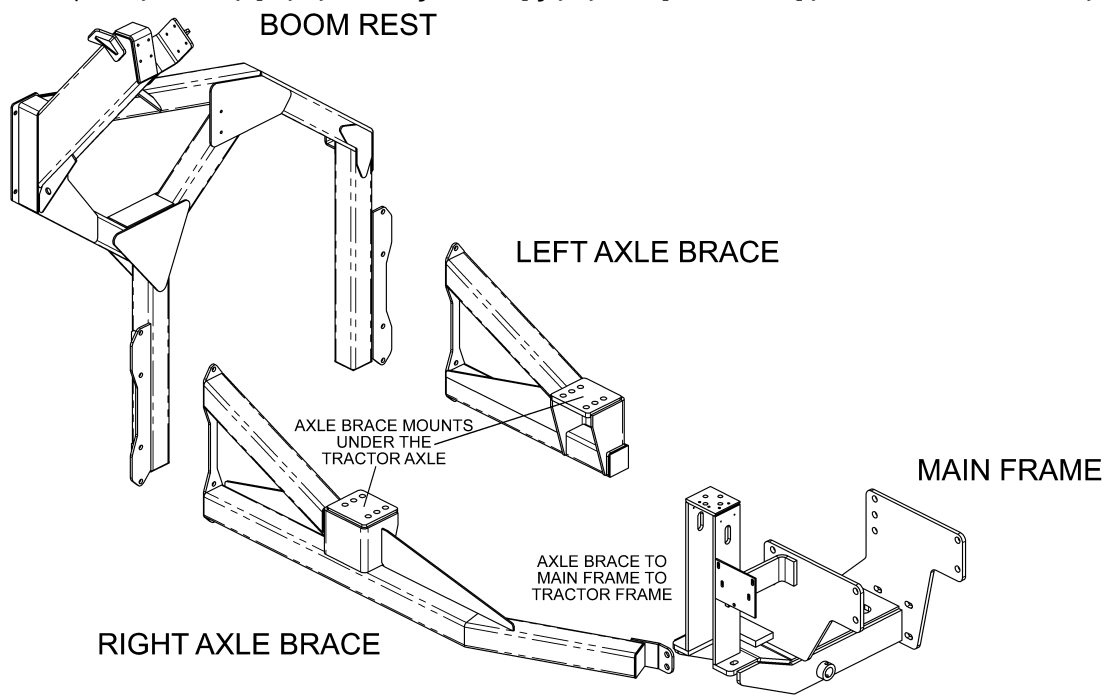

FG'6 C C A F 9 G H ' A C I B H B ;

O s e ~ | | A s e A o A ^ s A s a Q , A s [[{ | . o s a a A s a } A o A Q | . A s o A Q . ^ A A o A s e | A s | s e A E A [, a . c a | A s | s e s e Q * A s a , s e A s e A Q , } A s A o A U s o A U ^ & c A } A [. ^ | E A s a | , A | A o A s a } { ^ } c A s o c @ A ^ A s a A A @ A s e | A s | s e A v a c } A s | ~ ^ A s A o s a , s e A A } A o A s | s e A s a A o A s [[{ | . E Q s e | E s a a A o A . o c a . A A o A s [[{ | . s e A Q , } A s A o A U s o A U ^ & c A } E (ASM-JDBOOM-0001)



5 GG9 A 6 @M

' !DC=BH'GD5 7 9 F '6 @C7 ? G

V [Á@] Á caãã ^Á@ Á-È [à Áe{ • Á } Á [~ !Ác&ç !Á[!ÁU] ^ } ÁUç , ÈS^* çÁÜ^æÁUç , Á !ÁV!á | ^
+aaÁç] |ãcaã } • È-ÈU[à ÁU] æ^! • ÁÇUÐ ÁÈ HÌ ÈÈ Ì ÁBÁÈ HÌ ÈÈ JÐ , ^^áÁç Á^Áç • caç^áÈÁM Ácaç&@
@Á] æ^! Áa[& • Á } ÁRÖI | HÈÁç áÁRÖI FHEÁUç çáæáÁc&ç ! • ÈÇET T Áç &^ , • ÁÇUÐ ÁG Ì Ì ÈDáç á
HD +Áçæ , æ @! • ÁÇUÐ ÁHÌ Ì ÈD , ç!Á^ Á^ • ^áÈÁU } ÁRÖI GHEÁç áÁRÖI HHEÁUç çáæáÁc&ç ! • ÈFÍ T T
&ç • &^ , • ÁÇUÐ ÁÈ Ì HÈI G Dç çáÁ Ð +Áçæ , æ @! • ÁÇUÐ ÁHÌ Ì D , ç!Á^ Á^ Á^ Á^ • ^áÈÁM (ASM-C-0036)

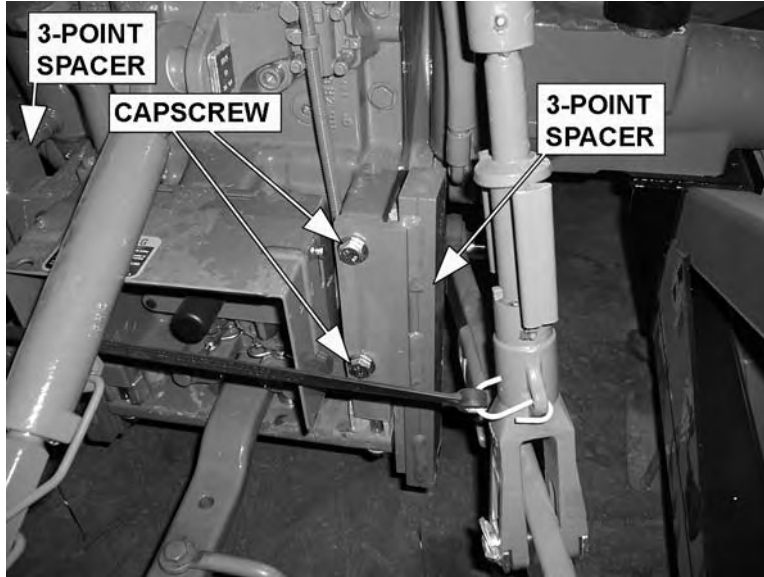

5 GG9 A 6 @M

; F95 G9 @ GG'6 95 F=B; 'BGH5 @ @5 HCB'

Q5 A^& { ^ } a^a^@A!^e^A^ A^A^A^] | a^A^ A^@ A^ | ^A^ A^A^ A^ A^ • A^ | A^ } A^ A^ | ^e^ A^ | ••
 à^æâ * B^ ASM-GRSLSS BRNG-0009)

Assembly

When a PolyLube™ bearing is press fit into a housing, it expands into the housing and creates a highly loaded press fit condition. This is possible because of the elastic properties of the bearing's backing material. Press fits on wall thicknesses up to 1/8" have demonstrated

that the close-in ratio is one-to-one (0.001 press yields a 0.001 close in). However, press fits should be minimized, even though the tube will readily take presses of 0.004" to 0.005". The use of a standard H7 housing bore is also recommended.

Due to thermal lag, the bearing wear surface may be hotter than the adjacent housing, when heat is generated from running friction. As a result, the installed bearing may expand inward, reducing the shaft clearance. For optimum performance, Polygon recommends a smooth, hardened steel shaft with a 16 micro finish. However, PolyLube's rugged bearing surface will permit use of a rougher finished shaft, such as a standard drill rod, if the bearing to shaft clearance is increased. (See Part # listings for recommended shaft clearances).

Shaft clearances should be increased for dry running applications with high rubbing velocities. Fluid cooling and lubricants will reduce the operating temperatures, permitting tighter shaft clearances. Heat transfer through the bearing wall is inversely proportional to the wall thickness. The thinner the wall, the greater the transfer of heat. Thermal conductivity, for example, is 1.8 to 2.3 Btu • in/(hr • ft² • °F).

Typical installation tools are illustrated below:

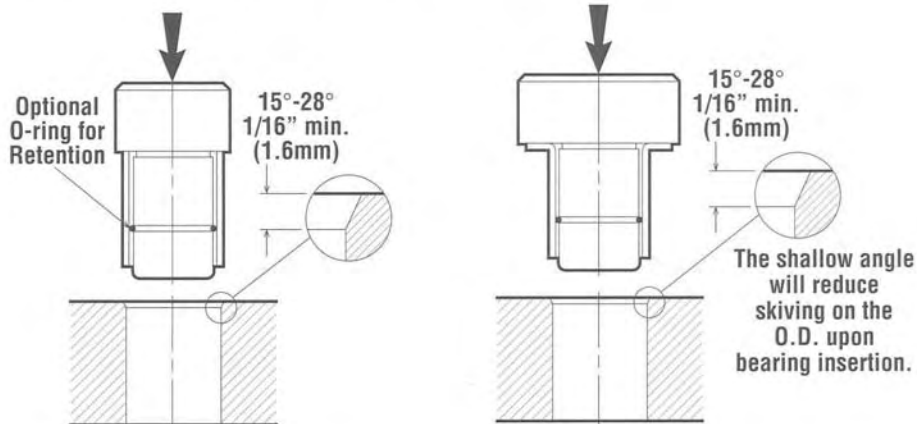
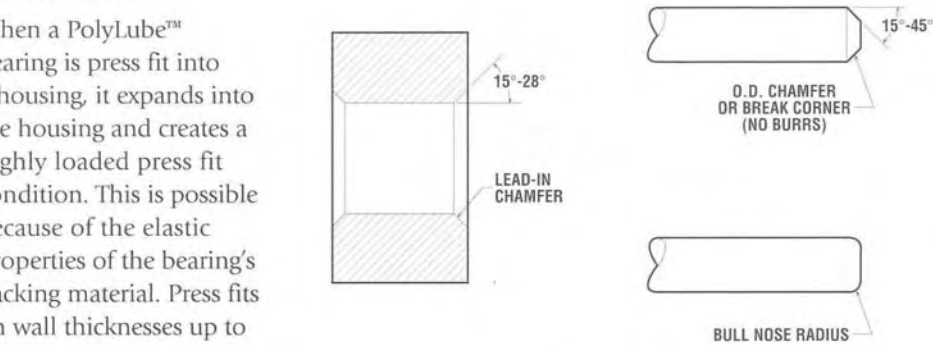

STANDARD BEARING INSTALLATION

FLANGED BEARING INSTALLATION



5 GG9 A 6 @M

DF9: CFA98`HI 69`BGF5 @@HCB

Šæ Á[[{ • Á } Á[[[Á[Á@ Á ä^ Á ä@ Á ~ Á | ä^ Á } Á Á] ÉÁÁ [~ } ç * Á ä ä @ ! Á @ ä ä É
 [] | Á @ Á ä ä Á[[{ Á à^ Á • ç | ä ä } Á Á ~ ä^ Á ÉÁÁ & ä Ä ç Á à^ Á & ä] • Á ä Á • ç | Á @ { Á [• Á |
 ä Á @ Á | ä^ Á } • Á } Á @ Á - Á ä^ Á Á @ Á[[{ • É

Ö! ä * ^ Á @ Á à^ Á ä ä Á @ • Á Ä ~ ç ä^ Á Á @ Á ä @ Á ^ & ä } Á ä ä ! ä ÉÁÁ • ç | Á @ Á { ç | Á Á à^
 & [• Á • Ä Á @ Á[[{ Á ä { ÉÁÁ ä * Á ä ~ | Á [Ä Á ä] & @ Á Á à^ Á ÉÁÁ ä Á @ Á ä * ^ Á à^ Á ~
 @ Á { ç | Á à^ Á ÉÁÁ } * Á ä | ä ä] Á | | ÉÁÁ ä Á [Á ä @ } ÉÁÁ @ & Á ç | Á à^ Á | Á | ! ^ & ä ä } { ^ } c
 ä ä Á @ Á [] ^ Á ä Á ä & @ ä Á | Á ^ } ÉÁÁ @ Á ä ä] Á | | & ä Á [, Á ^ Á ä @ } ^ ä ÉÁÁ (ASM-C-0016)

897?`5H57<A9BH

V @ Á ç | ä ä • ^ } à | Á Á • ^ Á Á ä ä @ Á @ ä ä Á Á @ Á ^ & [] ä ä Á Á[[{ ÉÁÁ • ç | Á @ Á ^ & Á ä ç | c
 & | ä ä^ Á • ä * Á @ Á ä • Á ä ä ä ä , ä^ ÉÁÁ @ Á Á | • ç ä ä ä Á @ Á { { [] Á ^ & ä } É

Ö [] ^ & Á @ Á ä ä * Á ä ä Á @ • Á Á | { Á @ Á ç | ä ä | ä ä^ Á Á @ Á { ç | Á | ^ | { ^ ä Á à^ Á } Á @
 à [{ Á ä { ÉÁÁ Ö [] } ^ & Á @ Á ä ä * Á ä ä Á @ • Á Á | { Á @ Á [ç | Á Á Á ä * ^ Á | ^ | { ^ ä Á à^ Á } Á @
 à [{ Á ä { ÉÁÁ Ö [] } ^ & Á ç | Á ^ } ä ä ä * Á @ • Á Á | { Á @ Á & [] d [| Ä ç ä ^ Ä ç Á @ Á & | ä ä^ Á • Á ä ä Á |
 | ^ | { ^ ä Á à^ Á } Á @ Á[[{ Á ä { ÉÁÁ ^ Á | Á | Á | { { [] Á ^ & ä } Á | Á ä ä ä ä • ÉÁÁ (ASM-C-0018)

K 95H<9F!D57?#A9HF≠D57?`5 GG9 A 6 @M

V @ • ^ Á • d ~ & ä } • Á ä | | Á Á [ç | Á ^ ä @ ! ÉÁÁ ä ä ä ä Á ^ d ä ä ä & [] ^ & | • É

BCH9.1 gYh YgdYWZWrcc`Zcf`h Y`hdY`cZWbbYWcf`nci`UfY`UggYa V`b[]
 (ASM-C-0009)

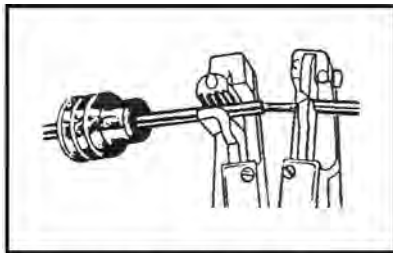

1. Apply seal to cable, before stripping insulation.



2. Align seal with cable insulation.

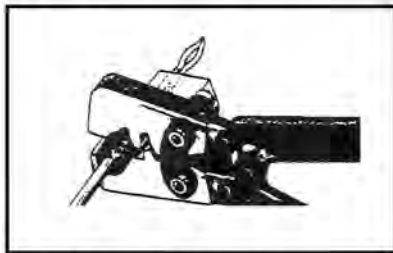

3. Put terminal in crimping tool, then

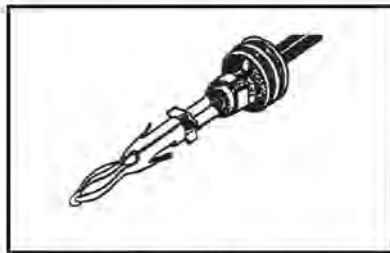

4. Crimp and visually inspect for a good



5 GG9 A 6 @M

Ü~ } Áæ&ç | Áæ } | { æ } | ^ | ææ * ÁÜÜT Áæ Áæb • ó@ Á ^ çæ * • Áæ Áæ || | , • É

GYHh Y'XYUX'VUBX'Wta dYbgU]cb'dchYb]ca YHf'Zfgh'

Ü^ ó@ Áæ Áæ áæ áæ | { } ^ } • ææ } Á [ç) ç { ^ ç | Áæ Áæ ÉÁ ÉÁ | Áæ , æ Áæ ç ^ } Á ~ || Áæ | & , æ ^ Áæ á ~ || Áæ ~ } ç | ÉÁ | & , æ ^ É

Ü^ çæ * ÁÜæ } æ Áæ æ ææ } ÁÜ [ç) ç { ^ ç | • K

Öä & } } ^ & ó@ ÁÖ^ • & @ Áæ } } ^ & ç | • Á [{ Áó@ Áæ ç æ | • Á - Áó@ Áæ ç ^ ÉÁV ^ Áæ Áæ [| ÉU @ Á ^ ç | Áæ { ^ æ ~ | ^ Á æ } æ Áç | çæ ^ Áæ á Áæ b • ó@ Á æ } æ Áæ æ ææ } Á [ç) ç { ^ ç | • Áæ Áæ ^ á á á ÉÁÜá ÁÁ Áæ dæ&ç | Á ~] | Áç | çæ ^ ÉÁÜá ÁÁF/Á Áæ } æ Áç | çæ ^ Á [{ Áó@ Áæ ^ çæ ÉÁæ á Á á ÁÁ/Á Á | ~ } á ÉÁÖá • ç { ^ æ ~ | ^ Á ~] | Áç | çæ ^ Áæ ç ^ } Á á • Á Áæ á á ÉÁV @ } Á ^ æ ~ | ^ Á æ } æ Áç | çæ ^ Áæ ç ^ } Á á • Á Áæ á Há @ Áæ á çæ * Áó@ Áæ ^ çæ Áæ } & ç } Á ~ | Áæ Áæ | çó@ Áó@ Áæ á Áó@ Áæ | | óá á & ç } ÉÁÖá æ Áó@ Áæ } æ ç | çæ ^ Áæ Áó@ Áæ ~] | Áç | çæ ^ Áæ Áæ ç á } æ Áç | çæ ^ Áæ Áæ Áæ Áæ ~] | Áç | çæ ^ ÉÁV @ Á Á | & } çæ ^ • @ ~ | á Á | óá Áæ • Áó@ Áæ Á Á Áæ | Áæ | Áæ Áæ Áæ Áó@ Áæ | { ÉÁV & } áæ Áó@ Áæ | { ÉÁV ÁÜ , æ ^ | ~ } & ç } ÉÁV @ Á Á | & } çæ ^ Á @ ~ | á Á | óá Áæ • Áó@ Áæ Á ÉÁ Á Á | Áæ | Áó@ Áæ Á GÁ Áæ | Áó@ Áæ & ÁÜ | || ~ } & ç } ÉÁV [ç Áó@ Áæ áæ Áæ çæ * • Áæ | Áó@ Áó@ & ÁÜ | || Áæ ~ } & ç } Á @ ~ | á Á | ^ ç } ó@ Áæ | | | Áæ | { • @ çæ * Áæ ç Áæ æ Áæ After making this first adjustment to deck roll if the spool still goes into float, adjust the "B" port screw additionally counterclockwise.

Ü^ & } } ^ & ó@ ÁÖ^ • & @ Áæ } } ^ & ç | • Á } Áæ | ç | | Áó@ Áæ ^ Áæ Áæ ç æ | • Á [Áó@ Áæ } Áó@ Áæ ç { • Áç æ ç ^ ÉÁÜ ~ } Áæ æ ç | ~ } ç Áó@ á á æ | Áæ ^ • ç { Áæ Áæ Áæ | ^ | ææ * Áæ { } | ^ æ ~ | ^ ÉÁV [, Á ^ á Áó@ Áæ b • ç ^ } ç Á - Áó@ Áæ á } æ ææ ææ } Á [ç) ç { ^ ç | • Áæ | Áæ | çó@ Áó@ Áæ á Áó@ Áæ | | ó Áæ | Áæ | | | | ç } æ Á ~ } & ç } • Áæ Áæ ç ^ Áó@ - | | | , á * Áæ } & ç } Áæ ^ ÉÁV [ç Áæ | } á * Á [ç) ç { ^ ç | Áæ | & , æ ^ Áæ & ^ æ ^ Áó@ Áæ | , Á | Áó@ Áæ } & ç } •] ^ á ÉÁæ á áæ | } á * Áó@ { Áæ ~ } ç | ÉÁ | & , æ ^ Áæ & ^ æ ^ Áó@ Áæ | , Á | Áó@ Áæ } & ç } Á ^ á ÉÁV [ç ÉÁæ á | á * Áó@ Áæ | | & á ~ | ^ Áó@ Áæ á Á [ç) ç { ^ ç | Áæ Áæ ç Áæ ~ || Áæ ~ } ç | & | & , æ ^ Áæ ~ ó@ Áæ } & ç } Áæ • ç | Áæ | Áæ ç Áæ ^ Áó@ Áæ ^ & ç } æ Áæ ç } • Áæ Áó@ Áæ æ ~ æ Áæ ç æ | Áæ } á Á - Áó@ Áæ ç ^ Áæ & ç } Áæ Áæ | çó@ | | á á Áæ | , ÉÁV | } Áæ á á & ^ , Áæ Á | Áæ | & , æ ^ Áæ Áæ á Áæ | , ÉÁV @ Á] | ^ Áæ á á & ^ , Áæ á Áæ | , Áæ Áó@ É] | | ç Áæ á Áó@ Áæ | , ^ Áæ á á & ^ , Áæ á Áæ | , Áæ Áó@ É | | ç Áæ | , ^ ç | Áó@ Áæ UV Áæ b • ó@ Áæ á á & ^ , Á } % É | | ç Áæ Áæ & Á | || Áæ ~ } & ç } ÉÁV áæ * Áó@ É | | ç Áæ | Áæ | ^ ç } ó@ Áæ æ Áæ } & ç } É



5 GG9 A 6 @M

A5-B6CCA. %GEÁU[:dZÖ [{ ÁM K Á ÈÉÁ^& } á•

(Note: Extend secondary boom completely; roll deck to be level with ground, and lower main boom until deck is on ground. Now index main boom “up” function and determine the time required for main boom to rise completely.)

%GEÁU[:dZÖ [{ ÄÖ [, } K î È Á^& } á•

(Note: Extend secondary boom completely, roll deck to be level with ground, and raise the main boom to “full up”. Then index the main boom “down” function to determine the amount of time required for the deck to contact the ground. CAUTION: Stop the boom just as the deck contacts the ground.)

G97CB85FM

6CCA K %GEÁU[:dZÖ [{ ÁÚ d K î ÈÉÁ^& } á•

(Position main boom full up, roll deck out until deck cylinder is fully retracted, and bring secondary boom in completely. Then index the secondary boom “out” function and determine the time required for boom to extend out completely.)

ÄÄ

%GEÁU[:dZÖ [{ ÁQ K î ÈÉÁ^& } á•

(Position the main boom full up, roll deck out until deck cylinder is fully retracted, and extend secondary boom completely. Then index the secondary boom “in” function and determine the time required for boom to come in.)

897?FC@@ %GEÁU[:dZÖ ^ & ÁÚ d Ä È Á^& } á•

(Raise main boom to vertical, extend secondary boom out slightly so that deck can be articulated without contacting the main boom, and roll deck in until deck cylinder is completely extended. Then index the deck roll “out” function and determine the time required for the deck to roll out.)

%GEÁU[:dZÖ ^ & ÁQ K Ä * ^ Ä È Á^& } á• ÁÚ d ÖUÁ U V Á • ^ Ä Ä ä Á^& , D

(Raise main boom to vertical, extend secondary boom out slightly so that deck can be articulated without contacting the main boom, and roll deck out until deck cylinder is completely retracted. Then index the deck roll “in” function and determine the time required for the deck to roll in.)

6CCA

GK =J9 @% %GEÁU[:dZÖ [{ ÁÉÄÄ F I È Î Á^& } á•

(Extend booms completely; rotate head to be level with ground, lower main boom until deck is just above ground, and swivel boom full forward. Then index the boom swivel “aft” function and determine the time required for the boom to swivel aft. Use caution when doing this, stop boom before main boom contacts tire.)

%GEÁU[:dZÖ [{ ÁQ [, æ ä K F I È Î Á^& } á•

(Extend booms completely, rotate head to be level with ground, lower main boom until deck is just above ground, and swivel boom aft and until near tire. Then index the boom swivel “forward” function and determine the time required for the boom to swivel full forward.)



5 GG9 A 6 @M

(ASM-DF CALIBRATION LRS-0001)

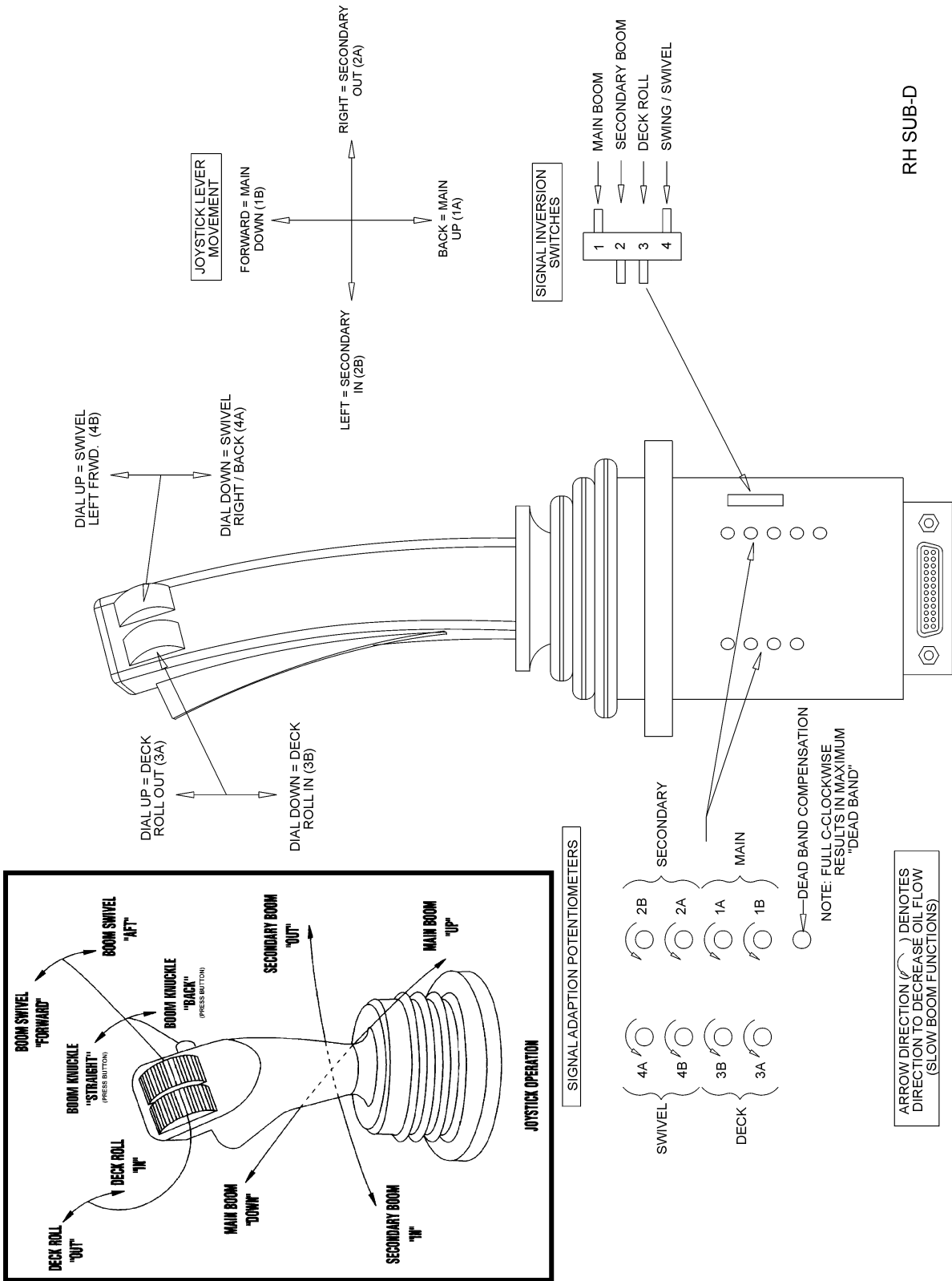

5 GG9 A 6 @M

: B5 @DF9 D5 F5 HCB: CF`CD9 F5 HCB

Ujæ^Á] ^iæ | CÁ æ^c Áæ áÁ] ^iææ } Á^&æ^ Á } Á@Á c^iá * Á[{ } Áæ áÁ æ^Á } . [| Á @ | ^ c@ ^ Áæ^Á^æ | Áæ æ^Á Á@ Á] ^iææ | ÉÁV@ . ^ Á^&æ^ Á @ | áÁ^Á } á^ . d [áÁ^ Áæ@] ^iææ | Á ~ c@ Á æ@ ^ Á } b } &æ } Á æ@ Áæ^c Áæ áÁ] ^iææ } Á^&æ } Á Á@ Á [| ÉÁV@ Á^&æ^ Áæ^Á á^Á } ææ ^ áÁ Á [| áÁ } áæ } Áæ Áæ^ { } á^ Á d Á@ Á] ^iææ | ÉÁæ áÁ @ | áÁ^Á^ | æá áÁ áæ æ^ áÉ

Qæ æ^ ÉÁæÁ [. . . ÉÁ] á . Áæ áÁ æ [ó] [á . Á . áÁ] ^ áÁ Á^ áÁ Á^ Áæ^ áÁ Áæ . d ~ &c^ áÁ Ác@ Á ææ c } æ & Á^&æ } Á Ác@ Á æ æ ÉÁÁV@ Á@ áæ | Á^ . ^ . c [áÁææ Áæ . [Áá^Áá^ áÁ æ@ Á ^ Á { { } } á^ áÁ^ áÁæ^ Áæ c } æ & Á^&æ } Dæ áÁc@ Ác^ Áá . æ^ áÁ Á@ Á] Á Ác@ Á æ | É Ö | á^ Á@ & Á Áæ^ Áæ * . Áæ áÁæ c } ^ . ÁÓÓÓUÜÓÁ ææ * Áææd | ÉÁV@ [Á^&^ Áæ^ Á [. . Á@ . . d * ^ c@ | Á æ@ áÁ Áæ . Áæ áÁ | æ Á æ@ | áÁ . . Á @ | áÁ^ Áæ } Á æ Á & Á] Ác@ Á . . É



ÓÓÓUÜÓÁ ææ * Á | Á] ^iææ * Á@ Áææd | Á [^ Á ~ . c^ áÁ Áæ áÁ } á^ . cæ áÁc@ Á Áæ^c Áæ áÁ] ^iææ } Á^&æ } . Á Ác@ Á æ æ^ { } | ^ c | É

69`G1 F9`H<9`65 @J5 @9G`5F9`CD9B`... Uææ^c Áææd | Áæ áÁæ [, Áæ . d { } ^ } c Á Áææá^ É Wá * Áææ áÁ Á æ^ Á] Áææá [æáÁ Á [c^ áÁ Ác@ Áæ^c Áæ áÁ ææ c } æ & Á^&æ } . É&@ & Áæ ææ * . Áæ áÁ } } ^ &æ } . Á | Á@ áæ | Áæ^ . É

Qæ^ Áæ Áæ Á^ } áÉ [^ Á ~ . c^ @ áÁ [, } Ác@ Áææd | É^ . c^ @ Áæ^ c^ Á] Ác@ Á^ | } áÉÁÓ^ | ^ ææ { } cæ * Á Áæ^ Ác@ Áæ É [^ Á ~ . c^ ææ Ác@ Áæ^ cæ^ Ác@ á^ . Á^ c^ Áæ^ . Á d Á^ | áÁæ^ | ^ . . ^ | ^ Ác@ Áá . É

6 YZ`fY`cdYfUjB [`H`Y`a`ck`YfÉ@ &^ c^ Á@ ææáæ áÁ [[Á @ | áÁ^Á] , | Á [c^ áÁc@ | ^ * @ | ^ c @ Á | Áæ * ^ Á Á [cæ] ÉÁV æ&@ Á Áæ^ Á } áæ } Ác@ Á [| áÁæ . . Á á &æ * Á | Ác@ . . Á d . . Á } c@ Á@ . . ÉÁV@ Á c^ iá * Áæ áÁ [} Áæ^ Áæ^ Á @ | áÁæ [Á^ Áæ^ ~ | Á [c^ áÁc@ | ^ * @ | áÁ | | æ * ^ Á Á [cæ] ÉÁV Áæ^ Á } áæ } Á &æ ! . Á Á @ Ác@ Á@ . . Á } ææc@ Áá . Éc@ Á c^ iá * Áæ áÁ [| Á] Áæ^ Áæ^ Áæ áÁ ^ áÁ Áá áÁ Áæ Áá . & æ^ áÁ Ác@ Áææd | Á] ^iææ | CÁ æ æ ÉÁV@ . @ | áÁæ [Á^ Á] ^ Ác@ Áá . Á áÉ | Áæ^ Ác^ | ^ Á [. . Á Áæ^ Á c@ | Á ææ Ác@ Á [, ^ Á ~ &æ c@ Á@ áæ | Áæ } Á | Áææ^ Áæ ÉÁV@ Á ææ & ^ áÁæáá * Á @ . É | Áæ b . cæ * Á d | Á [c^ Ác@ Ác@ dææd | Á] cæ Á [c^ Ác@ Á] | á^ { ÉÁV @ | Ác@ & á * Á [cæ] É [^ Á @ | áÁæ [&@ & Ác@ Ác@ Á] d [&æ æ Áæ^ Á } } ^ &c^ áÁææ | áá * Á Ác@ Á] ^iææ | CÁæ^ Á Ác@ Áæ^ Ác@ á^ . É

ACK 9F`H9GHB;

Væ Ác@ Áææd | Á Áæ | Áæ^ Á^ Á [. . Á ab & Á] Ác@ Á [^ } áÉÁV] ^iææ Ác@ Áæ | áá^ . Ác@ | ^ * @ c@ áÁ | Áæ * ^ Á Á [cæ] Áæ ææ ÉÁ Áæ^ Ác@ Áá . Á Áæ ÉÁV [| | , Ác@ Áæ . d ~ &æ } . Á Ác@ Á] ^iææ } . ^ &æ } Á Á] ^iææ Ác@ Á [, ^ ÉÁV áææ } Á Ác@ Á [, ^ Á @ | áÁ^ Á á á æææ Áá . ÉÁV c^ Áá { } á^ c^ Á . c^ } Éc@ Á } áÁ | c^ Á @ | áÁ^ Á^ d | ^ áÁæ áÁ } & Áæ ææ Áæ^ Ác@ Áá . c^ , Á@ | ^ . Á ~ [] ^iææ } É

Z UbmIdUfhg`cZk`Jg`5`ggYa`V`mGYWj`cbžcf`Ubmich`Yf`gYWj`cb`cZk`Jg`a`Ubi`U`UfY`bchWYUf`mii`bXYfglcc`X`nci`a`i`ghWc`bHJWinc`i`f`XYUYf`cf`H`Y`UXXfYgg`cb`H`Y`Z`cbhcZ`H`Jg`a`Ubi`U`Z`f`Uggj`ghUbwW` (ASM-C-0010)



CD9 F5 HCB'G97 HCB

UJ^!aa } A^&a } A#

CD9F5HCB

%CD9F5HCF`F9EI`F9A9BHG

Ùæ^Á] ^íææ } Á -Á@Á } æÁ Á@Á | ^•[]] •æææ Á -Áæ~ ææá áÁ] ^íææ | ÈÁÓÁ~ ææá áÁ] ^íææ | Á@Á ^ææÁæ á
 ~ } á^•ææ á Á@Á Á] | ^{ ^ } óææ áÁæææ | ÁU] ^íææ | çÁT æ } æ Áææ áÁæ Áæ] ^íææ } &^áÁ Á] | ^{ ^ } óææ áÁæææ |
 [] ^íææ } Áæ áÁæ | Áæ • [&ææ áÁæææ Á] æææ • ÈÁÓÁæááá } Áç Á@Áæææ Á ^••æ^•Áæ } ææ ^áÁ Á@Á æ } ææ
 •æææ Á æ } • Áæ^Áæææ^áÁ Á@Á Á] | ^{ ^ } óææ áÁæææ | ÈÁÓÁæ } Á æóÁ -Á@Á] ^íææ } Áæ áÁææÁ •^Á -Á@Á
 ^~ æ { ^ } óæ Á] óæ { } | ^{ ^ } Á } á^•ç [áææ] • | óææ Áæ ç | á^áÁæææ^Áæ | Áææ { } | ^{ ^ } ç] æææ } È

ÇÁ@Á] ^íææ | Áææ } [óÁææÁ@Á æ } æ Á] Á@Á { •^ç^•Á] Á [óæ { } | ^{ ^ } Á } á^•ææ áÁ@Á] ^íææ } Á -Á@Á
 ^~ æ { ^ } óæ Á Á@Á^•[]] •æææ Á -Áæ~ ^íçæ [| Á Á^ææÁæ áÁæ] ææ Á@Á æ } æ Èæææ Á] æææ • Èææ á
 [] ^íææ } Á • ç & ç } • Áç Á@Á] ^íææ | È

Ùæ^Á] ^íææ } Á -Á~ æ { ^ } óÁ~ á^•Á@Á@Á] ^íææ | Á ^æÁæ } | ç^áÁU^•[]] æÁU | ç&ç^Á@~ æ { ^ } óçUÓU
 ç | Á@Á áÁæ] ááá } • Á @ } Áææææ } • È] ^íææ } È^íçææ } Èææ áÁ^] æææ } Á@Á~ æ { ^ } óÁUÓUÁæÁæ • æ } ^áÁæ
] | çæ^Á] ^íææ | Á] | ç&ç } Áæ áÁæ &^ á^•Á@Á Á] | , æ } Áæææ Á ^ææ

D9FGCB5 @DFCH97HJ9`9EI`DA9BH`DD9L

- ~ Çæ • Á ^æÁæææ Á@æ • •
- ~ PæáÁææ
- ~ Ùæ^Á] ^íææææ Áç [ç ^æ
- ~ Ó] ç^•
- ~ P^æææ } ÁU | ç&ç }
- ~ Ó] •^Áæææ } Á@æ } çææ }
- ~ Ù^•] áææ | Á] Á@Á ç^Áæ \ Áç^ ^ } á^•Á } Á
 [] ^íææ } Áæ } ááá } • È (OPS-U-0002)

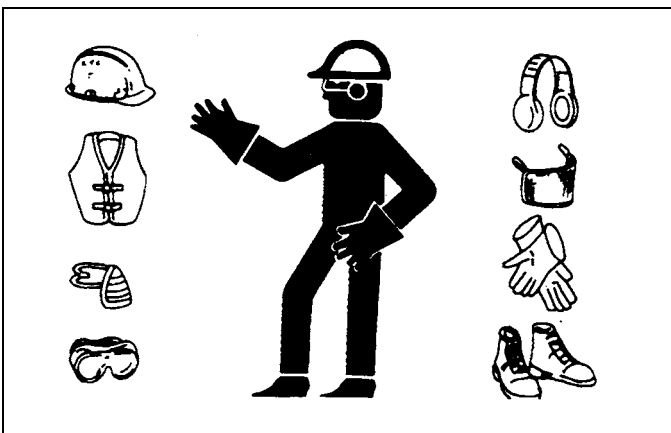

ΠΟΧΟΥΑ^•Áæi^••Á] Áæææ ç | Áæ { ^áææ^ Áæ^ç | ^Á] Á @^Á] ^íææ } Á@Á
 V íæææ | Áææ áÁæ] | ^{ ^ } óÁU^••Áæ áÁ æææ ç | Á, ç | Áææ^æ&Áææ Á] ^íææ | ç
 æ^ç^••Áæ áÁæ [| ááæ æææ } Áææ áÁ@Á^ç | ^Áææ&Á@Á] ^íææ | ç Áææææ Áæ
 [] ^íææ Á@Á~ æ { ^ } óÁææ^ ÈÁU^ç | ^Á] ^íææ } • Á@Á íæææ | Á] Á@Á] | ^{ ^ } óæ
 æ Á] ^íææ | Á } Á] ^•&æ çæ } Á] Á ç^íç@Èæ } ç^íÁ ^áææææ } Á ~ óæ } • | ç
 ææ ^áææææ | | ^••æ } æÁ^•ææææ } Áæ } Áæ^Áæ&Á -Á@Á ^áææææ } Á@æ
 , [^ | áÁ@Á á^•Á@Á@Áææææ Áæ Á] ^íææ Á@Á@Á~ æ { ^ } óÁææ^ ÈÁΠÓΧÓU
 \ } , æ } ^Áæ] , Áæ ^ [] ^Áæ Á] ^íææ Á@Á~ æ { ^ } óÁ @ } Á@Áææ^ç^••Á]
 & [| ááæ æææ } Áæ Á] ææ^áÁU^íá } • Áæ ç^Á] Áææææ Á@Á] ^íææ | Á] Á@Á
 &^ | áÁ^• | óæ Á@Á] ^íææ | Áæ } á^•Á@Á ç^ ^ } &^ Áæi^••Á] Áææ ç | ÈÁUÈÈÈ D

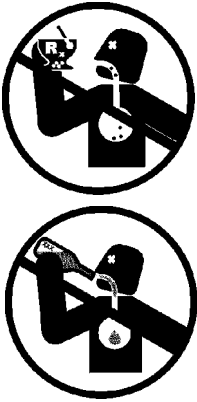

CD9F5HCB

Ó] { U] ^íææ } ÁU&ç } ÁÈH

CD9F5HCB

CD9F5HCB

Uphill

When operating the boom on level ground, the maximum weight of the boom is 1500 lbs. When operating on a 5-degree slope, the counterweight must be used to maintain stability. The counterweight is located at the rear of the machine and is used to balance the boom when it is fully extended. The counterweight is not used when operating on level ground.

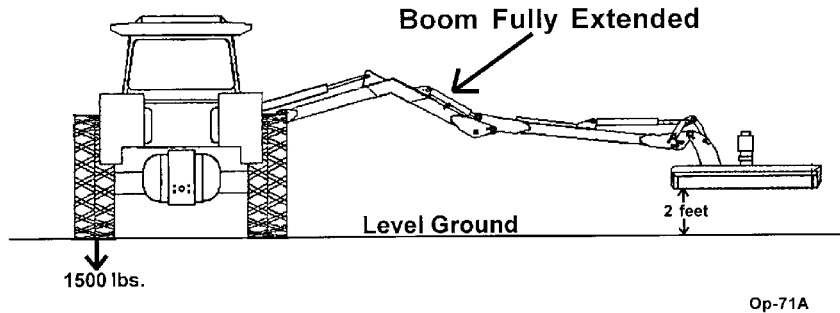

When operating the boom on a 5-degree slope, the counterweight must be used to maintain stability. The counterweight is located at the rear of the machine and is used to balance the boom when it is fully extended. The counterweight is not used when operating on level ground.

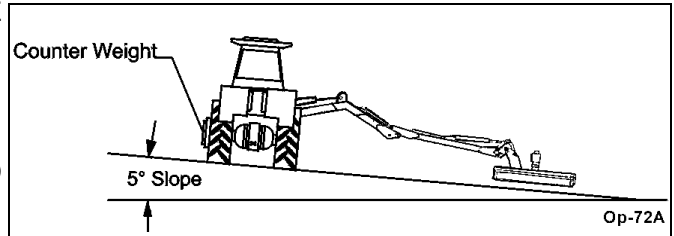

9HCB; CB5B8C: : H<9HF57HCF

When operating the boom on a 5-degree slope, the counterweight must be used to maintain stability. The counterweight is located at the rear of the machine and is used to balance the boom when it is fully extended. The counterweight is not used when operating on level ground.

WARNING

When operating the boom on a 5-degree slope, the counterweight must be used to maintain stability. The counterweight is located at the rear of the machine and is used to balance the boom when it is fully extended. The counterweight is not used when operating on level ground.



Uphill

Uphill

CD9F5HCB

CD9F5HCB

('GH5 FHCB; 'H<9 'HF57 HCF

V@Á] ^iæ |Á ~ • Á@æ^ Áæ [] | ^ Á } á ^ i • æ ã ä * Á ~ Á@Á | æ { ^ } &ç } Èæ ã Á] ^ i æ } æ Á • ^ Á ~ Áæ dæç | Á [] d | • Á ^ i | ^ Á æ ç * Á@ Á æç | ÈÁ ^ ç ä, Á@ Á æç | Á] ^ i æ | ç Á æ ~ æ Áæ á Á [] • | çæ Áæ ç | ä á á ^ æ | Á | Á æç | Á] ^ i æ } / • d ~ &ç } • Á ^ á á á È

Ö • ^ } æ Á i æç | Á [] d | • K

- " S | æ Á @ Á } æ } Á ^ È, æ & @
- " S | æ Á @ Á } * ä ^ Á @ ç ~ Á [] d |
- " S | æ Á @ Á @ ä i æ | æ Á [] d | | Á ç ^ i • Á
- " S | æ Á @ Á ä @ Á [] d | | Á ç ^ i
- " S | æ Á @ Á i æ ^ Á ^ ä æ ç æ ä & @
- " S | æ Á @ Á VU Á [] d | | Á
- " S | æ Á @ Á Á [ä ç @ & @] d | | Á ç ^ i
- " S | æ Á @ Á [[{ Á] ^ i æ } Á [] d | | Á ^ • æ Á | Á ç ^ Á æ } \ D

Ö ^ i | ^ Á æ ç * Á@ Á æç | Á } • | ^ Á @ Á [] | | , ä * Á

- " Ö [] ä ~ &ç | Á | ^ È æ ç | ^ i æ } / • | ^ &ç } Á æ á Á ^ ç æ Á æç | ä ä * Á Á@ Á æç | Á] ^ i æ | ç Á æ ~ æ Á
- " T æ ^ Á ~ | ^ Á | ^ Á ~ æ á • È @ | ä • È æ á Á @ | Á æ ç Á ^ ç æ Á • Á ^ Á ^ & | ^ | / Á | æ È
- " V@Á æ ä ä * Á i æ ^ Á } È
- " V@Á æç | Á æ { ä • ä } Á ç ^ i • Á æ Á æ | Á | Á ^ d æ È
- " V@Á [[{ Á] ^ i æ } Á [] d | | Á ^ Á @ Á ^ d æ æ á Á ~ Á [• æ } È
- " V@Á VU Á [] d | | Á ç ^ i / Á æ ^ } * æ ^ á È
- " V@Á @ ä i æ | æ Á { [ç Á [] d | | Á ç ^ i • Á æ Á @ Á ^ d æ Á [• æ } È

Ü ^ Á | Á Á@ Á æç | Á , } ^ i ç Á æ ~ æ Á | Á æç | Á æ ç * Á [& á ~ | ^ • ÈÁ] | ^ Á æ ç Á@ Á æç | Á @ Á ^ æ á Á æ á á | ç á Á Á@ Á æç | Á] ^ i æ | ç Á ^ æ È Á ^ ç ^ i Á } æ • Á @ Á } æ } Á, æ & @ Á ^ Á @ | ç ä & æ * Á@ Á æ ç | Á [] | [æ È Ö ç | Á@ Á æç | Á } * ä ^ Á ^ } } ä * Èæ [æ Á æ æ ^ } æ Á } æ ç, æ @ Á@ Á æç | Á æ { ä • ä } Á | Á ç ^ i ç ^ á á } æ á Á ^ ç | ^ & ç á Á æç | Á [ç ^ { ^ } ÈÁ OPS-B- 0003



Þ ^ ç ^ i Á ~ } Á@ Á i æç | Á } * ä ^ Á æ Á æ [• á Á ä ä ä * Á | Á æ ç ~ ç æ æ ^ ~ æ ^ Á ç ^ } ç æ } ÈÁ @ ^ ç • ç { ^ • Á æ Á Á æ æ á [~ • Á | Á ~ | Á @ æ ç ÈÁ



Ü ç ç Á æç | Á } | ^ Á @ } Á [] | ^ | Á ^ æ á Á Á@ Á i æç | Á ^ æ ÈÁ ç ç * Á æ d æç | Á Á ^ æ Á æ Á ^ • | ç Á ä | ^ Á | Á ^ æ ÈÁ ^ æ Á@ Á i æç | Á] ^ i æ | { æ ~ æ Á | Á [] ^ i Á æ ç * / • d ~ &ç } • ÈÁ



Ö [{ U] ^ i æ } Á ^ &ç } Á È

CD9F5HCB

CD9F5HCB

'7CBB97HB; '5H57<-B; <958G'HC'H<9'6CCA'

FÉÁÚ cæóÁÀ Áææ&@ * Ác@Á æç| óÁ:æ& ^çDÁ Ác@ÁÀ [{ çD
 ~•å * Á ç Dæ áÁcæá, æ^ÉÁ^çææ&@c& &| å áÁ:Á Ác@
] æç| óÁ:æ& ^çDÁ •å * Á ç Dæ áÁ:| Á å •É

GÁV@ } Áææ&@c@ÁÀ [* |* ç DÁ Ác@Á [, ^çDÁ •å * Á ç D
 æ áÁcæá, æ^É

HÉÁ^ÁæÁç æ ç Á Á, ^Ác@ÁÀ [{ çDÁ [} Á Ác@Á [, ^çDÉ
 Ç•Ác@Á]] Á ç Dæ [~ @c@Á] áÁ Ác@ÁÀ [{ Áæ áÁc@
 { [, ^Áæ&@, æçæá, æ^É

I ÉV@ } Áææ } Ác@ÁÀ [* |* ç Dæ áÁc@Á æç| óÁ:æ& ^çDÁæ&@
 , æç ç ç Dæ áÁcæá, æ^É

Í Éç æç Á æ^Á ^ÁæÁÀ | ç É ~ ç Éæ áÁ ç •Áæ^Áæ @ } ^ÁÁ
 ^Á& [{ ^ } áÁÁÁ | ~ ^ÉOPS-B-0004_D

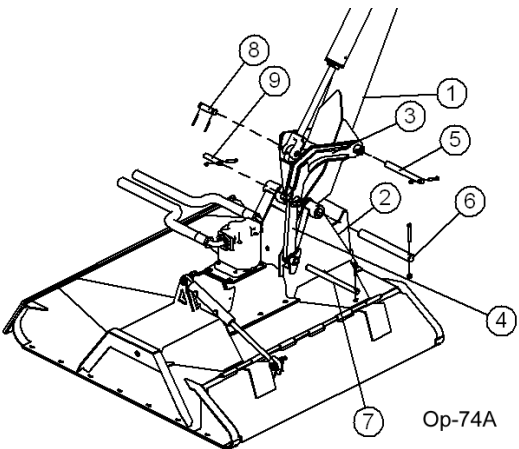

Çç| æÁ& } æ&ç æçç ç ^-æ& Áæ &| åå * Ác@áæ |æç çÁæ \ •É] { } É [ç | Éçæç^ Áæ á
 @ •^Á& } } ^æç } ÉÁÚ | ç Ác@áæ |æç | ^•• ^Áæ^ | ^Á | | | ç * Á æç ç } æ & Á | Á^ } æ •É
 W^Á& [ç^ Áæ áÁ^ Á | | ç &ç } Á @ } Á^ çæç * Áç ç | [] ^ } ÉÁÓ [} æ&ç æçç ç ^-æ&
 [Á^ æÁæ } Áæ •^Á^ ç ~ Áæ ç | Á [{ Á } • Á | Á &ç ç * ÉÁçÉD



Ö | Á [ç] ^Áæ Ác@ÁÓ ~ ç { ^ } ç æçç áæ |æç çÁ: ^Á^æ ç * ÉÁÚ ç
 æ áÁ ^Áæ^Áç [] • æ^Áæ áÁc@á | ^•^ } & Á& | áÁ | ^•^ } çææ æáÉÁÓ
 } [ç&ç & Á | Á^æ • Á æç [^Áæ æÁæ ç É] ^•• ^Á ç áÁ ç æ • Á | [{
 á^æ • Áæ Ác@Á ç ^Á& | áÁ ^ } ^çæ Ác@Á | ç Áæ áÁæ •^Áæ •^Áæ æ^
 ç &| åå * Á ç * ^ } ^ÁÉÁ &ç & Á | Áæç •^Á ç ÉÁPWÁc@Á } æçç ç ç
 UççÁæ áÁ^ [ç^ Áæ Ác@áæ |æç | ^•• ^ÁÉÁ ^æç çÁ [] ^ } ^çæ^Á [ç^ É
 •æç Á | æ^Áæ áÁ •^Áçæáæ | æáÁ &ç & Á | Áçæ^ } & Á - Á ç Áæ • ÉÁç
 ^ [^ •] ^çææ æ ÉÁÓ UççÁc@ Á UÜÁæ áÁc@ç Áæ • ç áÁæçç ç Á É
 ç Á Á [^•Á^ } ^çæ Ác@Á ç ÉÁç Ác@Áæ ç | Á^æ áÁ { ^áæ | Áæ
] @ • æç Á [, | ^•^ææ^Áæ áÁ ç | áÁ Ác@Á | & á ^ÁÉÁçÉD



* 'DF9!CD9F5HCB' -BGD97HCB'5B8'G9FJ=79

Ó ç | ^Áæ&@ • ^ÉÁ | ^É] | Áææ } Áæ •] ^æç } Áæ áÁ^ çæç Ác@Á [| { ^ } çæ áÁæç | Á ~ • óÁÁ | | | ^áÉ
 Vç Áæ &| áÁ Á | ç ^Á æç ç } æ & Áæ áÁ &ç á | áÁ^ á | æææ } É } ^æç * Ác@Áæ | Áæç Áæç Áæ^Á ~ ç] ^á
 æ áÁ^ } &ç } æÉæ áÁ | | | ç * Á ^ááÁ^ } æ • ÉÁÓ Á ç UÁ | | Áæ Ác@Á } áÁc@Á | | É] | Áææ } Áæ •] ^æç
 | ç^ ç ç Áæ ^ Á& | áæ } Áæ^ çç * Áæ^ Á | | Áææ } ÉÁÚ | | | Á^ } æç Áá^ } |æç | ^ } ç Áææ æ^áÁæ áÁ ç • ç *
] æç Á Á [] Á Á [ç ÁæÉÁÓ Á | | | ç * Áæç | | ~ ç | | É] | Áææ } Áæ •] ^æç } Áæ áÁ^ çæç Éæ æ | Á [, } Áæ ^
 æ áÁ^ } æ&ç | • çæ Áæ^Áæ [æ^áÉOPS-U-0029

Ó [{ U] | Áææ } Á^ &ç } ÁÉ

CD9F5HCB

CD9F5HCB

WARNING

U^i q a a e q A a j . ^ & o A e q A [c a * A] a e o A f i A , ^ a e A a a i ^ | a e A , @ } ^ & . . a e A a o a e o q i a ^ a A ^ i c a e A a e o E A S [[A i A [[. ^ A a e o } ^ i . E a [i] [i A a i \ ^) A j a e o E a j a A ^ a e A i A [[. ^ A a e q * E A T a e A ^ i ^ A e q A j a A o e A a e a e o * A o a a , a e E A U ^ i q ~ A b i ^ A e A & & i A i { A [o i a e a e q * A o e { a e o ^ A a A [[a A [i \ a * A i a ^ i E A U O E F E D

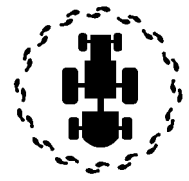

DANGER

O q i U a e c A U @ | a . E O ^ a a . A e a a U a e c A a ^ c a . A e & i a q * A G a ^ o y [c j a a a A q D E a o A O ^ i & q i . E O a e A O ^ a a . E U e ^ i A O ^ a a . E O ^ a e a i c U @ | a . E U V U A e o i a e A @ | a . E a j a A U ^ c a e a e A O [[i A U @ | a . A @ ~ i a a A ^ . ^ a A e a A e a e a A a A j A [[a A [i \ a * A e j } a a e j } E A O q i A e c A a ^ c a . A @ ~ i a A a a q .] ^ & o a A e a e ~ | | a e A a e o a e a e A i A a . a q * A i A i \ ^) & i { [] ^) o E A T a . a q * E a i \ ^) E [i A a [i] A e { . A ^ . o a A A } | a e a a e a } & A e A a a ^ & A o A j [. . a e a e A e b i ^ A i A e a e @ + [{ A o [, } A a b & o E a } a e * i ^ ^) e A i A i a e A e j } a e d E A U O T E D

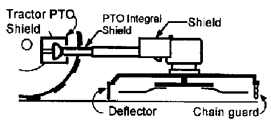

*** % H U W c f ' D f Y ! C d Y f U i c b ' b g d Y W i c b # G Y f j I W**

U ^ a i A q A o @ A c a e q i A j ^ i a e j i q A e j a e A i A . ^ i A e e & i {] i ^ e A i ^ E j ^ i a e e j } A a j .] ^ & q } A e a a A e @ a ^ i a . ^ i c a e A a e A i ^ i { i a A a e e j i a q * A q A o { a e ~ a e c i ^ i . A i ^ e j { { ^ } a e e j } . E A V @ A t I I I , q * a e A i { ^ A A o A e { . A o e A ^ ~ a ^ A e a e A i c a e A e a a q .] ^ & q } K



- " V a ^ A e j } a a e j } E a a j i A . . ^ i A
- " Y @ ^ i A ^ * A i | o A
- " U e ^ i q * A j \ a e ^
- " U V U A @ | a A
- " U T X A a } A e A e a e A e a A e a e A
- " V i a e q i q A a @ A e A e A e a e a e } & q } a e
- " V i a e q i A U a e A e A e A e A [[a A e j } a a e j } A
- " V i a e q i A U U U U A e A e A [[a A e j } a a e j }
- " U U U U A e A e A o A a e a e a A [. a e j }
- " E [A i a e q i A a A e a e . A
- " U a a e e j i A ^ A A A e a i a A
- " O) * a ^ A a A c ^ i A e a A e j } a a e j }
- " O) * a ^ A e j [i e o A c ^ i A e a A e j } a a e j } A
- " U [, ^ i A i a e A e a e A e A e A
- " U [, ^ i A e ^ i q * A e a e A e A e A
- " O ^ A e j } a a e j } A e a A e A e A
- " U ~ a e } o i a i a e e j } A e a e A e a e A e A [a o
- " O a A e A e j } a a e j } A O P S - U - 0 0 3 0

O i { U j ^ i a e j } A ^ & q } A e e

CD9F5 HCB

WARNING

Ü|aç^A@áiæ|æA|!••|^A|q|!A|!æ[q *æ^ A æ c) æ &A|A^| æA [| \A } A@AQ] | \A } dÉ
 Ú|æ^A@A [, |A^ææA } A@A| [~ } áA|A^&|^|A^~] [| c áA } A [& •A|Aæ á •ÉæA } *æ^
 c@ÁVUÉæ áA } | A -A@A } * q ^ÉÁ • @æ áA ~ |A@A } d [|Aç^A • A |A } •æA Aç^AæA
 ç A|aç^A|!••|^A|q|!A|!æ c) æ &A|A^| æA [| \A } A@AQ] | \A } dÉ

WARNING

Þ^ç^Aç^A@A [, |A^ææ } á^áA @^A@A@æA A A@Aæ^á
 [[•æ } ÉV@A [, |A|A~|áAæ|ææ • q *A^|q • A b|^A|æ } ^ [] ^A @
 { a @æ æç^A } ç A^A } á^A@A [, |A. AÚT É D



CD9F5 HCB

OUUT AEUJ AEUJOT OSY

- " Q • | ^ & A } áæ } A -Aæ@æ { A^&ç } A |á { ^ } c
- " O } • | ^ A | A } • Aæ^A | æ^É
- " O } • | ^ A | A | | • É } • Aæ áA [] | q • Aæ^A | [] | ^ | A
q • æ^AÉ
- " O @ & A } áæ } A -A • @ * • AæA [[] A ç [c
] [q • Aæ áA@áiæ |æ & | q á^|Aæ } *É
- " O } • | ^ Aæ@A@áiæ |æ & | q á^|Aæ } • æ^Aæ áA
|^æ^áA | | ^ & ç É O } • | ^ A @ A | [] | ^ A á^A } • A
æ^A • ^áA | Aæ A@ & | q á^|Aæ } • æ^Aæ áA
• ^ & | ^ áA | [] | ^ | É OPS-B- 0022_D



WARNING

Þ^ç^Aç^A@A [] cA | A^ | áææ Éæ b • É | A^ [ç^A | æ | æA [{ A@AQ] | \A } cA @^AæA
 [[ç] A | A @^Aæç | A } * q ^ A } } q * É AÚT É D

PYOUÇVSOASO OAD UJOOVQJP

- " O @ & A | A@áiæ |æ Aæ • Aæ } * Aq • ^ É
& | q á^|Aæ } • Aæ áAæ } • É = A D C F H B H A O U A V A
~ • ^ A [~ | A@æ á • Aæ & @ & A | A } q Aæ • É V • ^ A
] æ & A -A@æ^A æ | A | Aæ áA [æ áAæ & @ & A | A
@áiæ |æ A } q Aæ • É A
- " Q • | ^ & A @ A } áæ } A -A@Aç^A [] ç } q * É
- " O } • | ^ Aæ } • Aæ^A | [] | ^ | A } } ^ & ç áÉ
OPS-B- 0023_D

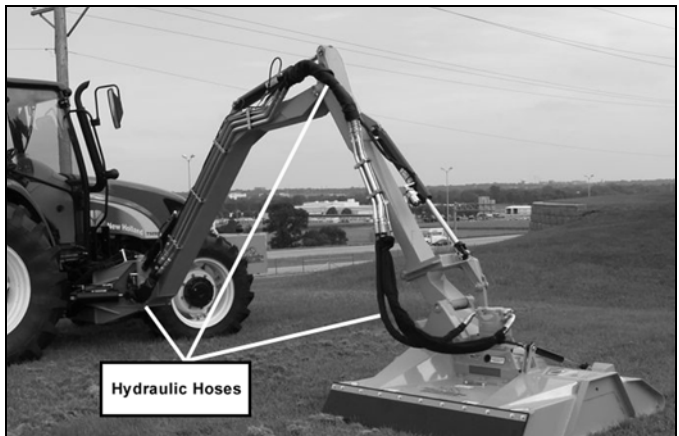

Ó [{

U | ^ æ } A ^ & ç } A É G

CD9F5HCB

CD9F5HCB

ÜUVÖÿÿÁÏÒÖÁÐÜÚÒÖVQIP

- “ Q.] ^&ö|æ^• Æ å Æ|æ^Æ [| Ö Á | Á [• ^] • • Á æ å Å ç & • • æ ^ Á ^ æ Æ Ü [æ ^ Á Á Ö Å Á æ ^ Á ÷ | Æ @ & å * Å æ Æ Æ Ü ^] æ ^ Æ æ æ ^ å Æ [] Æ æ å Å æ • å * Æ | æ ^ • Æ Å Æ [] | Ö Á ^ Ö Á Á { æ æ Á | æ ^ Æ æ æ & É
- “ Ö.] ^ Á [÷ | Æ [| Ö Á å Å ~ Ö Å ^ Å @] ^ å Á Á @ Å] | [] | æ ^ Á | ^ É
- “ Ö.] ^ Á ^ à Æ Æ ^ ÷ & ÷ | • Æ ^ Å Á [• æ] Å å Á } [ö æ æ ^ å Æ Ü ^] æ ^ Á [] Æ [\ ^] Æ å Á { æ • å * Å ^ & ç } • Æ { ^ å æ ^ É
- “ Ö.] ^ Á @ Æ æ | æ Å ^ • Æ ^ Á [] ^ | Æ } } ^ & ç å Á ÷ Á @ Á @ Æ æ | æ Á [÷ | Æ @ & Á | Á @ Æ æ | æ Á | æ • Å [] * Á • • Å å Å æ * • Æ Ü Á UV Á • Á ^ [^ Á @ å • Å Æ & Á | Á æ • Æ ^ Á æ Æ & Á [Á @ æ ^ Á æ ^ Á | Æ æ à Æ æ Å Æ & Á Á @ Æ æ | æ Á æ • É
- “ Q.] ^ & ö @ Å [] å æ } Á Æ & Á | æ Á @ ^ • Å å å, æ ^ Ö OPS-B-0025



WARNING

Ö | Á [Ö] ^ Ö æ å • Á | Á ^ Á } å ^ Á [, ^ | Á & • Æ Ö | æ ^ Á Ö] æ ö & æ Á ^ ~ | ç å Å ^ å ~ • Å Æ | ^ Á | Á ç ^ Á æ æ Ö Ü æ Å æ æ Á } ç | Á [ç] Á @ Á ÷ [] ^ å æ å Å @ Æ & • Æ ^ Á ^ & ^ | Æ [& ^ å Á] Æ



DANGER

Ö Á Ü æ ^ ç Á Ü @ | å • Æ Ö ~ æ å • Å æ å Á [@ | Á • æ ç Á å ç æ • Å & ^ å å * Á ç ~ Ö] [Ö] æ å Á ç Æ Ö Ö ^ ÷ & ÷ | • Æ Ü ç ^ | Á Ö ~ æ å • Å æ å Á Ö æ å [ç Á Ü @ | å • Á ^ ~ Ö å ^ Á • ^ å Å æ å Á | æ æ ^ å Å å Á [] å , [\ å * Å] å æ } Æ Ö Á æ ç Æ ^ Á @ ^ | å Æ ^ Å •] ^ & ç å å æ ~ | | Å ç æ ö æ æ Á | Á æ • å * [| Æ [\ ^] Æ [] [] ^ Ö Æ æ • å * Æ [\ ^] Æ | Á [] Æ ^ { • Á ~ ö Å Á ^] æ å Å ç } & Á Á ^ å ~ & @ Á [• • æ ç Á Å Æ | ^ Á | Á æ ç Ö [{ Á @ [, } Á å ö & Æ] æ * | ^ ^ ç | Á | æ ^ Á } æ ç

Ö [{ U] ^ | æ } Á ^ & ç } Á Æ |

CD9F5HCB

CD9F5HCB

OPERATION

- Read the manual before operating the machine.
- Do not operate the machine if you are under the influence of alcohol or drugs.
- Do not operate the machine if you are tired or if you have been drinking alcohol or drugs.
- Do not operate the machine if you are wearing headphones or earplugs.
- Do not operate the machine if you are wearing a hat or any other headgear that could obstruct your vision.
- Do not operate the machine if you are wearing loose clothing or jewelry that could get caught in the machine.
- Do not operate the machine if you are wearing safety glasses or contact lenses that could be damaged by the machine.
- Do not operate the machine if you are wearing a watch or any other jewelry that could get caught in the machine.
- Do not operate the machine if you are wearing a hat or any other headgear that could obstruct your vision.
- Do not operate the machine if you are wearing loose clothing or jewelry that could get caught in the machine.
- Do not operate the machine if you are wearing safety glasses or contact lenses that could be damaged by the machine.
- Do not operate the machine if you are wearing a watch or any other jewelry that could get caught in the machine.



Read the manual before operating the machine. Do not operate the machine if you are under the influence of alcohol or drugs. Do not operate the machine if you are wearing headphones or earplugs. Do not operate the machine if you are wearing a hat or any other headgear that could obstruct your vision. Do not operate the machine if you are wearing loose clothing or jewelry that could get caught in the machine. Do not operate the machine if you are wearing safety glasses or contact lenses that could be damaged by the machine. Do not operate the machine if you are wearing a watch or any other jewelry that could get caught in the machine.



Read the manual before operating the machine. Do not operate the machine if you are under the influence of alcohol or drugs. Do not operate the machine if you are wearing headphones or earplugs. Do not operate the machine if you are wearing a hat or any other headgear that could obstruct your vision. Do not operate the machine if you are wearing loose clothing or jewelry that could get caught in the machine. Do not operate the machine if you are wearing safety glasses or contact lenses that could be damaged by the machine. Do not operate the machine if you are wearing a watch or any other jewelry that could get caught in the machine.

U] ^{

U] ^{

CD9F5HCB

Tractor PRE-OPERATION Inspection



Mower ID# _____ Make _____

Date: _____ Shift _____



WARNING Read the operator's manual for the tractor and mower before operating. The operator must be trained and qualified to operate the tractor and mower. The operator must wear the seat belt and use proper operating procedures. The operator must not drink alcohol or use drugs before operating the tractor and mower. The operator must not operate the tractor and mower if they are tired or impaired. The operator must not operate the tractor and mower on a slope that is too steep. The operator must not operate the tractor and mower near children or bystanders. The operator must not operate the tractor and mower near power lines. The operator must not operate the tractor and mower near water. The operator must not operate the tractor and mower near traffic. The operator must not operate the tractor and mower near other equipment. The operator must not operate the tractor and mower near trees or other obstacles. The operator must not operate the tractor and mower near power lines. The operator must not operate the tractor and mower near water. The operator must not operate the tractor and mower near traffic. The operator must not operate the tractor and mower near other equipment. The operator must not operate the tractor and mower near trees or other obstacles.

CD9F5HCB

Item	Condition at Start of Shift	Specific Comments if not O.K.
The flashing lights function properly		
The SMV Sign is clean and visible		
The tires are in good condition with proper pressure		
The wheel lug bolts are tight		
The tractor brakes are in good condition		
The steering linkage is in good condition		
There are no visible oil leaks		
The hydraulic controls function properly		
The ROPS or ROBS Cab is in good condition		
The seatbelt is in place and in good condition		
The 3-point hitch is in good condition		
The drawbar pins are securely in place		
The PTO master shield is in place		
The engine oil level is full		
The brake fluid level is full		
The power steering fluid level is full		
The fuel level is adequate		
The engine coolant fluid level is full		
The radiator is free of debris		
The air filter is in good condition		

Operator's Signature: _____

DO NOT OPERATE an UNSAFE TRACTOR or MOWER

If you are not trained and qualified to operate the tractor and mower, do not operate the tractor and mower. If you are not wearing your seat belt, do not operate the tractor and mower. If you are not using proper operating procedures, do not operate the tractor and mower. If you are not wearing your seat belt, do not operate the tractor and mower. If you are not using proper operating procedures, do not operate the tractor and mower.

©

U] ^! a& } Á ^ & } Á È Ì

CD9F5HCB

Boom PRE-OPERATION Inspection



Mower ID# _____ Make _____
 Date: _____ Shift _____



WARNING 6 YZ:fY'W:bXi W]b['H Y]bgdYW]cbžā U_Y gi fY'H Y'fUWcf 'Yb[]bY]g'cZZU''fcHU]cb'\ Ug
 glcddYX' UbX' H Y'fUWcf']g']b' dUf_ 'k]H ' H Y' dUf_]b[' VfU_Y Yb[U] YX'' AU_Y gi fY' H Y'
 a ck Yf ']g'fYg]b] 'cb' H Y] fci bX'cf'gYW fYmiV'cW_YX'i d'UbX'U''\ mXfU']WdfYggi fY'\ Ug
 VYYb'fY]Y] YX''

Table 1:

Item	Condition at Start of Shift	Specific Comments if not O.K.
The Operator's Manual is in the tractor		
All safety decals are in place and legible		
The mounting frame bolts are in place and tight		
The boom connection bolts & pins are tight		
There are no cracks in boom		
The hydraulic cylinders pins are tight		
The hydraulic pump hose connections are tight		
The hydraulic valve controls function properly		
There are no leaking or damaged hoses		
The hydraulic oil level is full		
There is no evidence of hydraulic leaks		
The blades are not chipped, cracked or bent		
The blade bolts are tight		
The deflectors are in place and in good condition		
The boom shields are in place and in good condition		
The skid shoes are in good condition and tight		
There are no cracks or holes in boom deck		
The hydraulic motor mounting bolts are tight		
The boom head spindle housing is tight and lubricated		

Operator's Signature: _____

DO NOT OPERATE an UNSAFE TRACTOR or MOWER

Ó [{

U] ^! aā } Á ^ & cā } Á Ē Ì

CD9F5HCB

CD9F5HCB

Cable Controlled Mowers

OPERATOR'S MANUAL FOR THE CD9F5HCB CABLE CONTROLLED MOWER. THIS MANUAL CONTAINS IMPORTANT INFORMATION FOR THE OPERATOR. READ THIS MANUAL CAREFULLY AND KEEP IT FOR FUTURE REFERENCE.

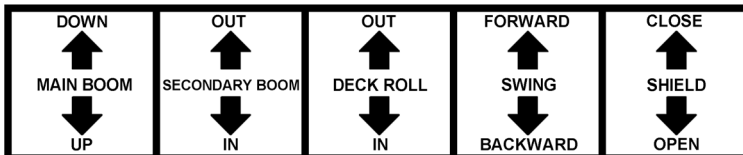

OPERATOR'S MANUAL FOR THE CD9F5HCB CABLE CONTROLLED MOWER. THIS MANUAL CONTAINS IMPORTANT INFORMATION FOR THE OPERATOR. READ THIS MANUAL CAREFULLY AND KEEP IT FOR FUTURE REFERENCE.

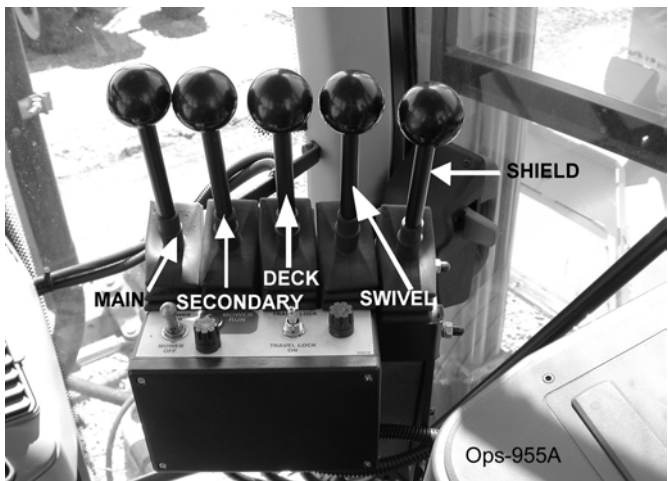
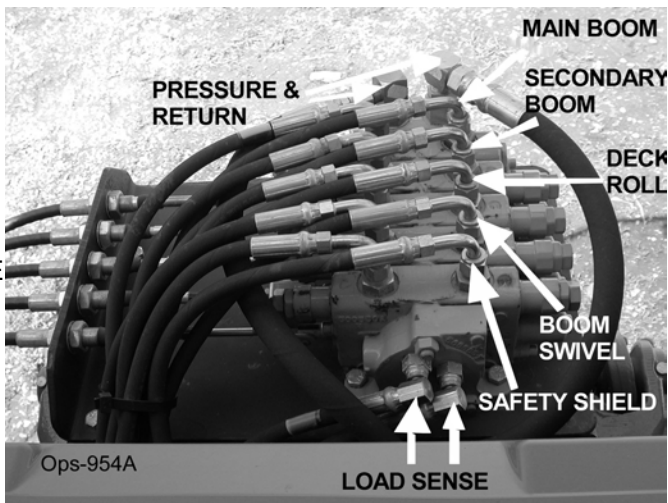

CD9F5HCB

CD9F5HCB

CD9F5HCB

* 'Y 'Gk JHW Vcl

V@ÁÚæc ÁÚ@|áÁç'íÁ] ^} • Áæ áÁ&| [• ^ • Á@Á @|á
 || &æ áÁ } Á@Á [] ç' Á@Á &ç' ç' Á@Á æÉY @) Á [çá *
 æÁ !Á ^æ Á@Á ! [~ } áÉæ, æ • Á@ç ^ Á@Á @|áÁ Á@
 &| • ^ áÁ [• æá } ÉY @) Á [, á * Áá Á@Á! ~ • @| !Áá
 ç^ • Áæ [ç' Á ! [~ } áÁ ç' | Á@ Á @|áÁ æ Á^ Á] ^ } ^ á
 † ! Á æ á ! Á &ç' çá * ÉÚ ^ æá Áæ áÁ || , Á@Á æ } á * Á }
 ç Á^ &ç' @ , } Á^ | , ÉÖ [Á [ç' ~ } Á@Á &ç' ç' Á@Á æ
 á ç Á æ' áá Áæ * ^ ! Á@ç Á ^ Áæ ^ ç' É

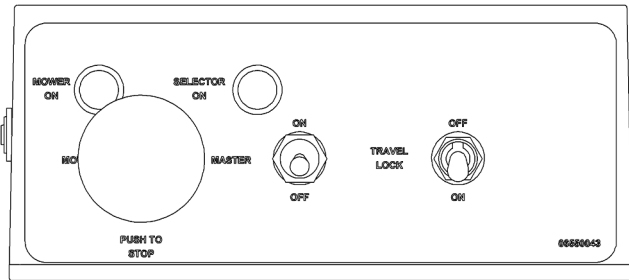

DANGER

SAFETY SHIELD & DEFLECTOR OPERATION

DEFLECTOR

- Failure to close Safety Shield and Deflector may allow objects to be thrown outward with great force which can cause property damage, bodily injury, or death.

1. Keep Safety Shield and Deflector fully closed when cutting grass and weeds to reduce possibility of objects being thrown outward by the Blades if persons are in the area.
2. Before Cutting brush, trimming limbs, or other such operations, raise the Deflector and Safety Shield fully to allow the blades to contact the material if area is clear of passerby. Operator must stop cutting and close shield if passerby enters the thrown objects area or blade contact area.
3. Repair or replace Safety Shield and Deflectors as needed.
4. Always transport with Safety Shield and Deflector closed.

02967867

Ö [{ U] ^ ! æá } Á ^ & çá } Á É Ç

CD9F5HCB

CD9F5HCB

ŠÒXÒÜÄÄFÄT ÖÄÄÓUUT

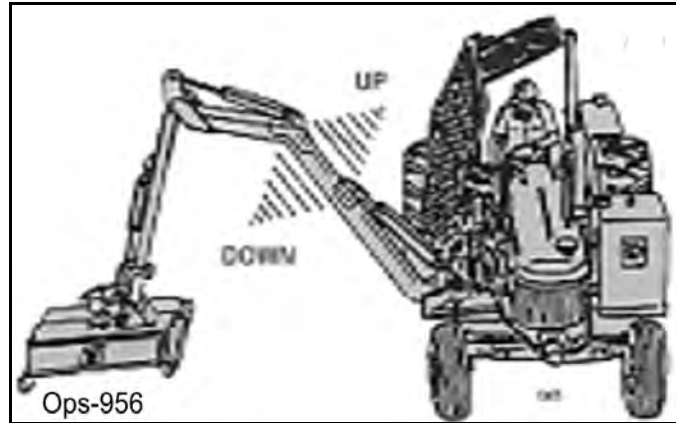

ŠÒXÒÜÄÄGÄÜÒÖUÄÖÄÜÄÓUUT

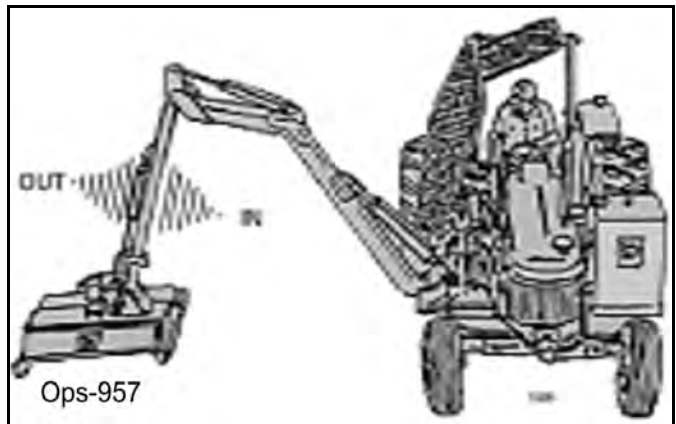

ŠÒXÒÜÄÄHÖÖÖSÄÜUŠŠ

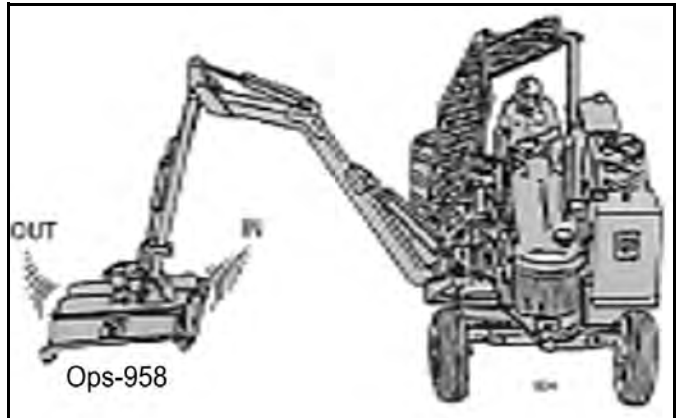

Ó[[{

U] ^! aä } Ä ^ & ä } Ä Ä F

CD9F5 HCB

CD9F5 HCB

ΣΧΟΔΙΑΣΜΟΣ ΑΥΤΟΜΑΤΟ

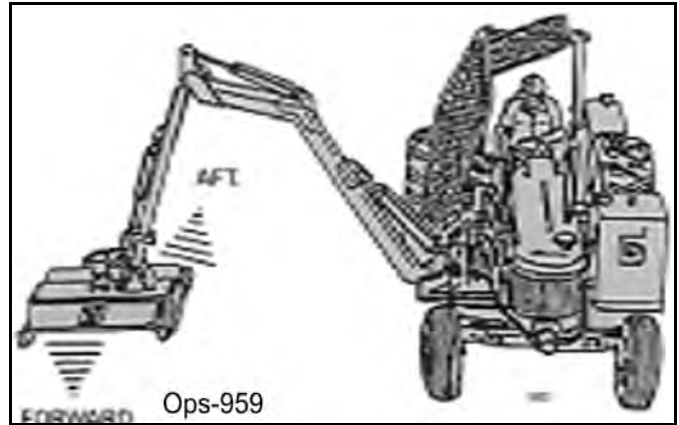

ΣΧΟΔΙΑΣΜΟΣ ΑΥΤΟΜΑΤΟ

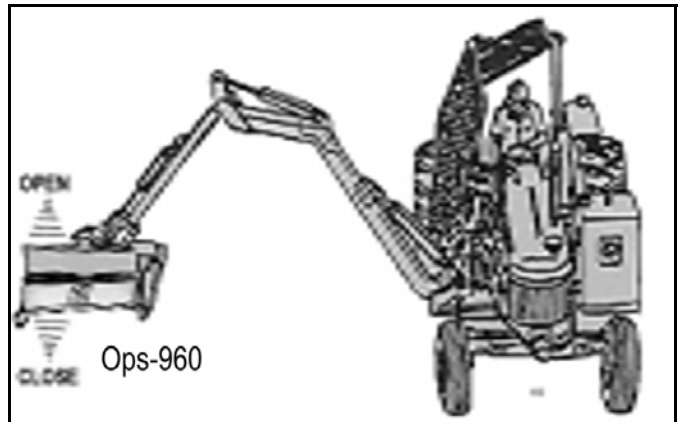

Όλες οι πληροφορίες σχετικά με τον CD9F5 HCB

είναι διαθέσιμες στην ιστοσελίδα μας www.alamogroup.com

CD9F5HCB

CD9F5HCB

WARNING

WARNING

Before operating the machine, read the operator's manual. Failure to read and understand the operator's manual may result in injury or death.

Always use proper lifting techniques. Do not lift or carry loads that are too heavy or awkward, or that require twisting or reaching in unusual positions. Always use proper body mechanics. Do not lift or carry loads that are too heavy or awkward, or that require twisting or reaching in unusual positions.

CAUTION

Always use proper lifting techniques. Do not lift or carry loads that are too heavy or awkward, or that require twisting or reaching in unusual positions. Always use proper body mechanics. Do not lift or carry loads that are too heavy or awkward, or that require twisting or reaching in unusual positions.

CAUTION

Before operating the machine, read the operator's manual. Failure to read and understand the operator's manual may result in injury or death.

Always use proper lifting techniques. Do not lift or carry loads that are too heavy or awkward, or that require twisting or reaching in unusual positions. Always use proper body mechanics. Do not lift or carry loads that are too heavy or awkward, or that require twisting or reaching in unusual positions.

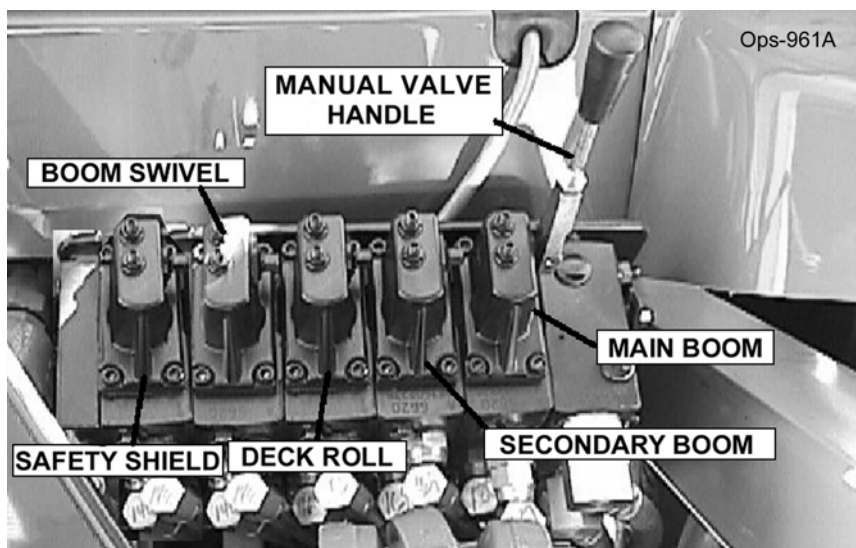

©

U] ^! } ^& } ^H

CD9F5HCB

CD9F5HCB

Control Panel

The control panel is located on the right side of the mower deck. It contains the following controls:

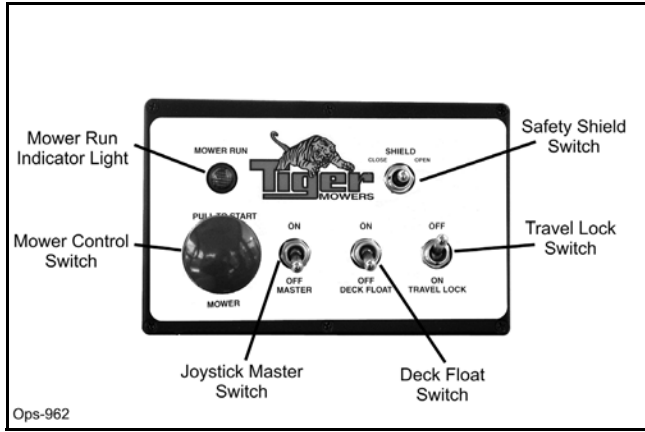

The control panel is used to operate the mower. The Mower Run Indicator Light indicates when the mower is running. The Mower Control Switch is used to start and stop the mower. The Joystick Master Switch is used to control the mower's movement. The Safety Shield Switch is used to engage the safety shield. The Travel Lock Switch is used to lock the travel control. The Deck Float Switch is used to adjust the deck height.

! DANGER

SAFETY SHIELD OPERATION

- Failure to close Safety Shield may allow objects to be thrown outward with great force which can cause property damage, bodily injury, or death.

1. Keep Safety Shield fully closed when cutting grass and weeds to reduce possibility of objects being thrown outward by the Blades and to prevent contact with the Blades if persons are in the area.
2. Before cutting brush, trimming limbs, or other such operations, raise Safety Shield fully to allow the blades to contact the material if area is clear of passersby. Operator must stop cutting and close shield if passerby enters the thrown objects area or blade contact area.
3. Repair or replace Safety Shield as needed.
4. Always transport with Safety Shield closed. Ops-963

©2011 Alamo Group Inc.

CD9F5HCB

CD9F5HCB

>cmghjW `7 cbhfc`

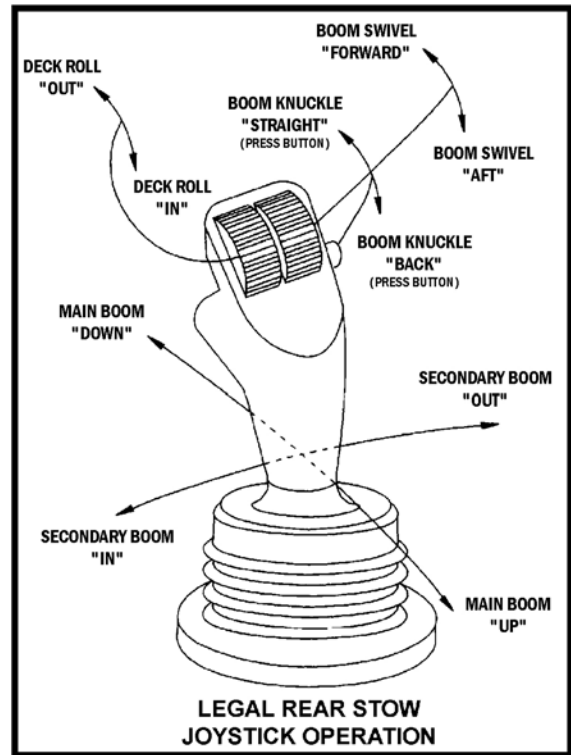
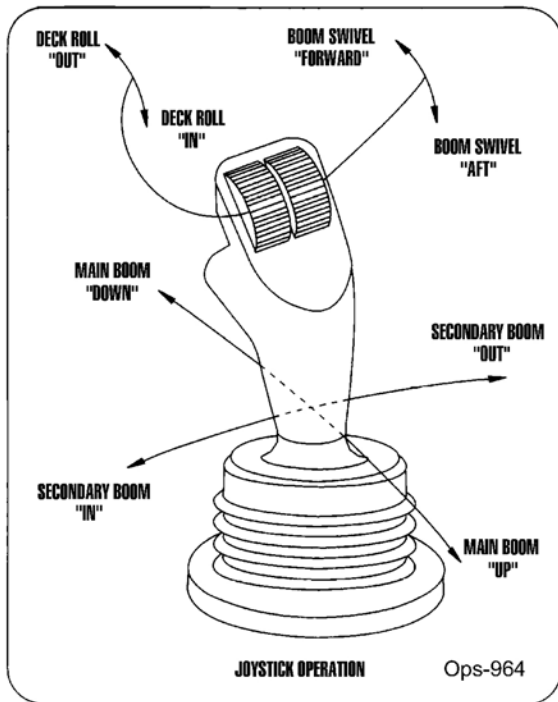

RUÿÙVÔSÁY ÖÖCÔSÁ UXÒÙÁ CD ÁÓUT

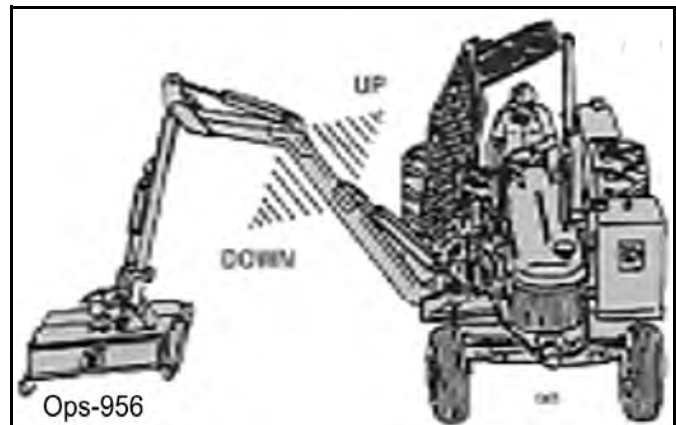

Ó[[{

U] ^! aã } Á ^ & ç } Á Ë Ì

CD9F5 HCB

CD9F5 HCB

RU'YUVWXSASZVWXPVAT UXOU'AU'OU'PO'AY' OOUT

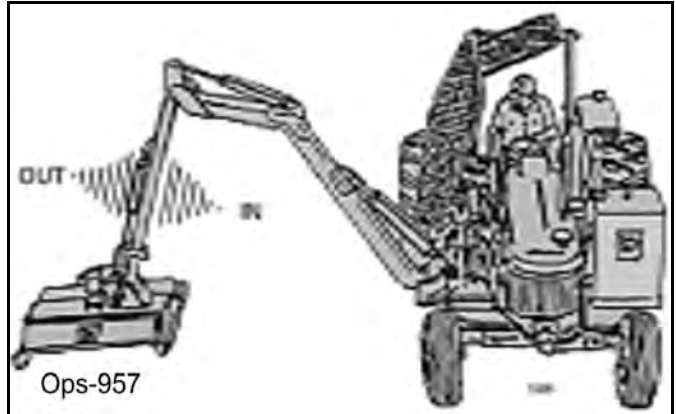

SZV'RU'YUVWXS'AU'SSOU'AT UXOU'AO'OS'AU'SS

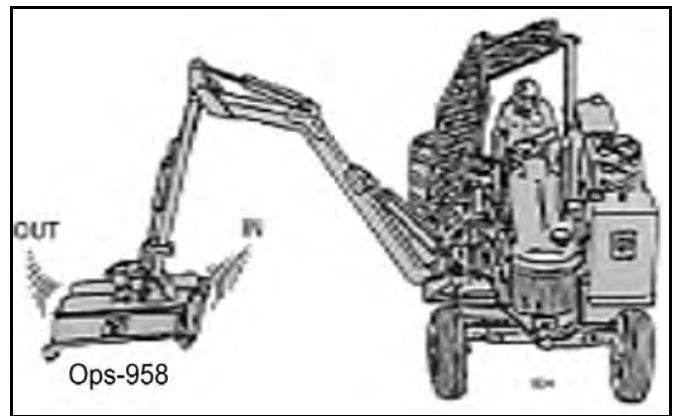

U'OPVA'RU'YUVWXS'AU'SSOU'AT UXOU' A OOUT UY'XOS

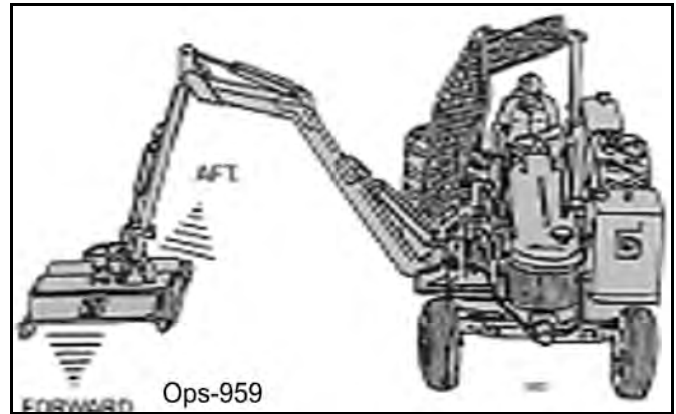

U'OPVA'RU'YUVWXS'AU'SSOU'AT UXOU' A OOUT UY'XOS

U'OPVA'RU'YUVWXS'AU'SSOU'AT UXOU' A OOUT UY'XOS

CD9F5HCB

CD9F5HCB

ÜÖPVARJYÜVÖSÄÜÜŠŠÖ ÜÄY PŠÖÄÜÜÖ ÜÜÖÖ
 ÓWVUPÁŦ UXÖÜÁÜUT ÁŠPWÖŠÖÁUPÁÖŠÖÖÖŠ
 ÜÖÖÜÁVUY ÁÜUT

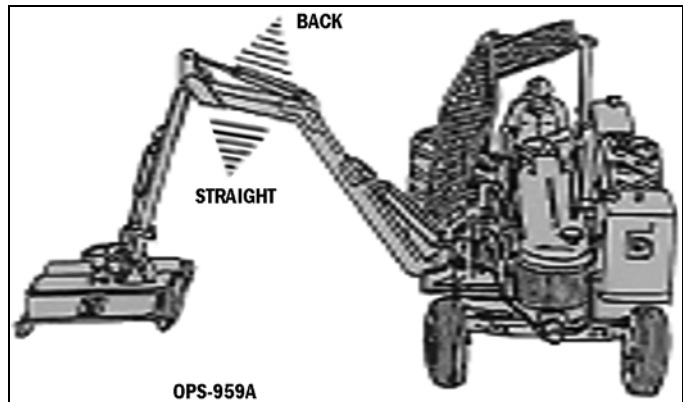

ÜPÖŠÖÄ ÜY ÖÖPŦ } Á •, ŠŠÖÄ äŦ ÖDÁ UÜÖÜÖVÖÜ
 ÜÖÖÖVYÁUPÖŠÖ

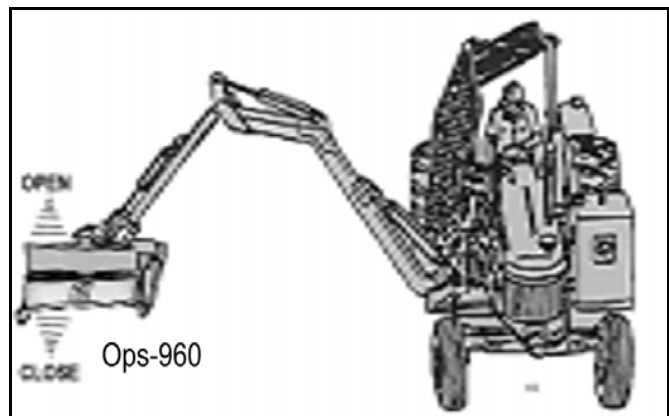

.'8 F=J-B; 'H<9 'HF57 HCF '5 B8 'A D@A9 BH

Üæ^ÁtædŦ!Átæ } [Ŧ!Á^~ ä^ÁÖ@Á] ^!æŦ!Át Á [••••ÁÖ@Ŧ! [~ @Á] [Ŧ!á^ÁŦ -ÁÖ@Á [ä^Áä^ * Á] ^!æ^á
 æ äÁŦ ^æ cŦ } •Át Áæ ^ÁŦ @^ÁäŦ * ÁŦ @Ŧ! Áææ&@äÁŦ] Ŧ{ ^ } ÖÖÖ • ^ÁÖ@ÁtædŦ!ÁÖ@ÁÖææ æšc Át
 Öæ äŦÁÖ@ÁŦ ^š @Ŧ! -ÁÖ@ÁŦ [Ŧ! Át äÁÖ@ÁtædŦ!ÁŦ] ^!æŦ! * ÁŦ } dŦ! • ÁŦ ^ÁŦ ^ÁŦ! Áæ^Átæ } [Ŧ!ÖÖÁŦ] • ^ÁŦæc
 , @^ÁäŦ * ÁÖ@ÁtædŦ!ÁŦ @Ŧ! [Ŧ! ÖÖÁŦ, ÁÖ@ÁŦ] , ä * É

Ü^æÄŦ!Áæc ÁŦ • dŦ! &cŦ } • ÖÖÖ &cŦ ÁŦ] ÁÖ@ÁŦ [Ŧ! ÁŦ æŦ! ÁŦ] ÁŦ æŦ! |æŦ! äÁŦ ~ |Ŧ! ^ÁÖææä • ÖÖ [Ŧ! ^ÁŦ &cŦ
 æ^Áææ&@äÁŦ [^ÁŦ ÁŦ] æŦ! -ÁÖ@ÁŦ [Ŧ! ÁŦ @Ŧ! ^ÁÖ@ÁŦ ÁŦ] [••••ÁÖ@Ŧ! æäÖÜ^ææ Át äÁŦ æ^ÁŦ ^ÁŦ [~
 ~] äŦ! • Öæ äÁÖ@ÁŦæc ÁŦ ^•••æ^ÁŦ! ^ÁŦ [~ ÁŦ] ^!æŦ! ÁÖ@ÁŦ] Ŧ{ ^ } ÖÖÖ ÁŦ ^ÁŦ &cŦ ÁŦ!æŦ! Át äÁŦææŦ!
 ÜŦ! |æŦ! • ÖŦ! ÁŦæ æ^ÁŦ &cŦ ÖÖ^ÁŦ! ÁŦæc ÁŦ &cŦ } ÁŦ! [Ŧ! Ŧ! { æŦ! } É

S^Ŧ! ÁŦ! ^!• [] ÖÁŦ ^!ÁŦ! ÁŦ! ÁŦ [, ^ÁŦ & ÁŦ! ÁŦ! ÁŦ! ÁŦ! , ÁŦ! äŦ & ÁŦ! @Ŧ! ^ÁŦ! ÁŦ! |Ŧ! &cŦ ÁŦ! ÁŦ! } • äŦ! äŦ!
 äŦ! & ÁŦ! ÖÖÖ ÖÖÖ ÖÖÖ ÖÖÖ OPS-B- 0005

ÖŦ! { UŦ! æŦ! } ÁŦ! &cŦ } ÁŦ! ÖÖ

CD9F5HCB

DANGER

Read the manual carefully before operating the machine. Failure to read the manual may result in injury or death. The operator must read and understand the manual before operating the machine. The manual contains important safety information. The operator must read the manual before operating the machine. The manual contains important safety information. The operator must read the manual before operating the machine. The manual contains important safety information.

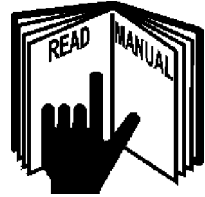

WARNING

Be aware of the danger of the machine. The operator must read and understand the manual before operating the machine. The manual contains important safety information. The operator must read the manual before operating the machine. The manual contains important safety information. The operator must read the manual before operating the machine. The manual contains important safety information.

DANGER

Do not operate the machine until you have read and understood the manual. Failure to read the manual may result in injury or death. The operator must read and understand the manual before operating the machine. The manual contains important safety information. The operator must read the manual before operating the machine. The manual contains important safety information. The operator must read the manual before operating the machine. The manual contains important safety information.

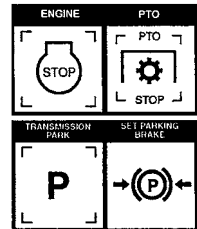

CD9F5HCB

CD9F5HCB

CD9F5HCB

- "G i Hbf '8ck b'h Y5 HUW YX< YUX!': cf'GfubXUF'9ei]da Ybh

V| Á @ oÁ[,) Áææ@áÁ [, ^!Á@ææÉá•oÁiá * Á@ dæd |ÁÁ ÁæÁ {] |ÁÁÁ d] ÉÖ^ & ^æ^Á * á ^ÁÚÚT d Ái |Á@) Áæ^ * æ^Áæ^ | @æÉV@Á [, ^!Á@ææ , áÁÁ { ^ÁÁ ÁæÁ & {] |ÁÁÁ d] Á , æ@ Áæ^ ææ|Á æ [~] oÁ ÁÁ ^ÉÖ[Á [oÁ) * æ^Á!Áá^ * æ^Á@ & æ^ | @æ•ÁæÁæÁ @ÁÚÚT Á } |Á•Á@!ÁÁá Áæ) ^ (^! * ^) & Áæ ææ } É



On-Off Switch

Úæ\ Á@Áæ æd |Á [] ÁæÁ^ç^Á~ | æÁÉ |æÁ@ dæ• { á•á } Áá Áæ Á |Á) ^ dæÁæ áÁæ] |Á@] æá * ÁææÉá @ oÁ[,) Á@Á * á ^ÉV { [ç^Á@ \ ^Éæ áÁ æÁ |ÁÁ [ç] ÁÁ & { ^ÁÁ ÁæÁ {] |Á • d] Á^ | ^Ááá * Á@Áæd |É OPS-B-0011_D



OOZUOÁæá * Á@Áæd |ÁÁææ, æ•Á^Á@Áæá * ÁæÁæá áá |Á^c @Áæd |Áæ { á•á } Áá Áæ á * Á^æÉáá^ * æ^Á@ÁÚVÉ d] Á@ ^ * á ^ÉV { [ç^Á@Á^Éæ áÁ æÁ |ÁÁ [çá * ÁæÁ Á d] ÉÁ |æÁ@ dæd |Á @Á^ç^ÁÁ d ÁÁ , Áæ^Á |Áæá * Á^æÁÁ |Á^ç^ oÁÁæd |Á { Á |á * ÉÁ^ç^Áá { [~] oÁÁæd |Á@ÁÁ [çá * Á |Á @Á@Á * á ^ áÁ } } á * ÉÁ |ÁæÁ@Áæd |Á d |Á { Á@Áæd |ÁÁæ } |ÉÜÖBĐ

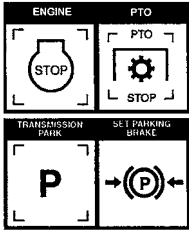

Ó [{ U] ^ææ } Á^ & ç } ÁÉU

CD9F5HCB

CD9F5HCB

Operating Instructions: On-Off Switch

Operating instructions for the On-Off Switch, detailing its location and function within the operator's compartment.



Additional operating instructions and safety warnings, including information about the PTO and other machine controls.



Final operating instructions and safety warnings, including the reference code OPS-B-0013_D.

© 2011 Alamo Group Inc. U.S. Patent & Trademark Office

CD9F5HCB

CD9F5HCB

%%&HfUbgdcfjbl`cb`Di V]WFcUXk Ung

Òcđ^{\ ^Ếcẽ ầ } Á @`jảÁÁ^Á·^áÁ @}Ácđ·][lầ *Ác@Ácđđ |Áđ áÁ [, ^!Á }Á`àl&Ál ầ, ầ·ẾÁ/@Ácđđ | { ··ÁÁÁ~ ầ }l^áÁ ầ@ẾÁÁ~`á^áÁầc^Á ầ }ầ *Áầ`!·Á ầ }ầ *Áầ^ÚT XÁ\` à\{ Áđ áÁầ @`*Á ầ }ầ * lầ @`Á Á^!oá!ầ^!·Á Ác@Ácđđ |qÁ^·^&ẾÁ^ ^{ à^!Ác@Á ầ, ầ·Á^Álầ ầđ^!Á·á }^áÁl |Ác đ { [ầ^ á!ầ^!·Áđ áÁ [·oá!ầ^!·Á ầlÁ [oáÁ [lầ *Á`Á^!Á^`Ế@!^!l^Ế[~Á`·oÁ [lầ^oÁ |Á^Á |Áầ^ cầ, Á ầl[!·Á^~^}đ^Áđ áÁ^ ^{ à^!Ác@Á^oÁ^Á ầlầ }! ầ@Á ầ |^Á^&ầ·^Á |Ác@Ácđđ |qÁ, ^! ·]^^áẾÁÁ cđ^ ^!^Ácẽ ầ`·Á @}Ác@Á ầ&ÁÁ·Á`ầ } ^}Ác@Á [^Á^Álầ^ *ẾÁ Á ầ^!Ác@Ácđđ |ÁÁ , ầc@Á ầđ |Ác}·á·Á^` }áÁ^`lầ^ÁÁ·Ác@Á ầẾÁ OPS-B-0014

V@Á ÚT XÁ Q]l , Ế [ầ *Á X^ẾÁ^Á ^{ à\{ Á ầ ` }ầ^!·ầ^!·{ ầ |Á·^!Á ầ^!` |oá!ầ^!·Á |Ác@]!·^·^&Á·Á·`ầ { ^}Ácđđ |ầ *Á }Á [ầ, ầ·Áầầ··[, Á·]^^áẾÁÚT XÁ ầ }·Áầ^Ácđđ ầ *|ầÁ:lầ @ [lầ *Á ầ^!·^&ầ^Á^!áÁđ ầ |Á:lầ c@Á^·Áầ ầ áÁ ầ @^ ầ ầầầ ẾÁT ầ^Á·^Ác@ÚT XÁ ầ }Á ầ^! ầ ầ áÁ ầ ầ^!^!{ Ác@Á^!·Ác@Á } ầ^! ^!^ dầ }][lầ *Ác@Ácđđ |Áđ áÁ]|^ ^}Á }Á` àl& :l ầ, ầẾÁÚ^l ầ^Ác@ÁÚT XÁ^ à\{ ÁÁ·ầ^!áẾ ầ ầ^!áẾ |Á [}·^!Á^~&ầ^Ế OPS-U-0020



Op-43

T ầ^·^!Ác@Ácđđ |Ác@`*Á ầ }ầ *Á ầ @E @ầlầ @ Ế ầ áÁ àlầ^Ếầ |ầ Á ầ^Á·} &ầ }ầ *][|^!Á^!·Á^!Á |&^!á ầ *Á }đ Á]`àl&Á | ầ·Ế Y @Á^, ^!Á [á^!Ácđđ |·Ác@Á^!·cÁ·Á ầ * đ Á]cầ^Á ầ }ầ *Á ầ }ầ·Á ầ^!Á^!·Á ầ *Ế { [·oÁ [lầ^!Á { [á·!Á, @!ÁÁ]!Á·~ ầ }l^áÁ, ầ []^!ầ *Á ầ @ ẾÁÁ []·^!Á ầ @ lầ^!Ácđđ | á^!Á^!Á |Á ầ *Á ầ ầ áÁ [ầầầ }·Á ầ ầ^!· đ Á]*lầ^Ác@Á ầ *Á }Á |á^!Ácđđ |Á [á^!·Ế OPS-B-0015



Op-103

Ó[{

U]^!ầ }Á^&ầ }ÁẾ G

CD9F5HCB

CD9F5HCB

OPS-U-0024

OPS-U-0024



Op - 46

⚠ DANGER

OPS-U-0024

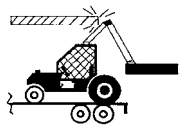

OPS-U-0025



Op-47

OPS-U-0025

CD9F5HCB

CD9F5HCB

OE:æ *^Ác@Á&@æ•Á•[Ác@æÁ, @}Áæ @^}^áÆÁc@
 &@æ•Á æ^Á~||æ*Á[], æáÁ æ áÁ æ ææ•c
 c@{•^|ç^•ÆÁæ^~||^Áæ @^}Ác@Á^&|æ*Á&@æ•Á!
 [c@!Áææç}^!•Á•æ*Áæ[[{^!•Á!Áææá^!•ÁçÁæ]]|^
 {ææ~{Áç}•æ}ÆÁÁ^Áæçd^ {^Á&æ^Á, @}
 æææ@*Áæ áÁ^ { çæ*Ác@Á^&|æ*Áæçæ•ÁæÁc@
 ^çd^ {^Áç}•æ}Áæ ç|ç^áÁ, @}Á!^ææ^áÁæÁc@
] [ç} ææÁ ç ç^Á!æ~•Áç b!^É



Y @^Áæ |æ*Ác@Ácæç!Áæ áÁæ]|^ (^) ç{ æ^
 [&ææ æ } æ^Áç]•Áç Á&@&Ác@æÁc@Ácæç!Áæ á
 æ]|^ (^) ç^Á^Á [ç^áÁ!Á çæáÁæ áÁc@Ác@
 •^&|æ*Á&@æ•Ác@æ^Á ææ ææ^áÁ}•æ}ÆÁÁ^!æ*
 çæ•][!çææáÁ!ææ*ÆÁç] Á!}æ*ÆÁ!Á, ^!çæ*
 ææç} Á æ^Á!ç|{^áÆÁç] ÁæÁc@Á^çææ^Á çææ]
 ç Áç•|&æÁc@Á^&|æ^Á Ác@Á çæÆÁOPS-U- 0026

CAUTION

Qææ^!Á[ç^!^&ç^Áç^!ÆÁc@Á[[{Á ç!Á} áÁÁ, æ*Á, æá•Ác@Á, ^!Áæ^ÆÁæ^Ác@!
]^!•[}]^!Áææ^ÁÁ[ç]d|ÁÁ, æ*æ*Á [ç] Á @}Á&|æ áÁ!Á çÁÁ^ { ç^áÆÁ æ^Á!^Ác@
]^!•[}]^!Áæ^Á [çæ]•æ} ÁÁ^Ác@Á!Á~•@áÁ^Á, æ*æ*Á[[{ÆÁ

Ü^çæÁ, æ^!Á çáÁæ áÁ&|Áæ Á æ Áæ ^ÆÁç] ç{ Á!, æáÁ Ác@Á} ç!Á Áææ^áÁ, ^!Á&Á ç
 c@Áæ^!Á^áÆÁ áÁ @ ç^Ác@Áæç |ÆÁçæç!Áæ áÁc@Á [, ^!Ác@æÁ ç^!áÁ [, Á&@æ^áÁ [, }Á&|Á!
 ç Ác@Áæ^!Á^áÆÁ

CAUTION

Qæ^Á æç^Ác@Á] ^!ææ*Á&ç]ÆÁ!Áæ^Ác@!Á&ç}Á Ác@Á æ~æ^Á [ç{]|^ç!
 ~}á^!ç [áÆÁ] çæÁ [^!Áæ^!Áæ^!Á!Ác@Áæá!•Á] Ác@Áç^!Á Ác@Á æ~æ^Á!
 æ•ææ&^Á

Ó[[{ U|^ææ}Á^&ç}ÁÆÍ

CD9F5HCB

CD9F5HCB

Ó[[{

U] ^! aã } Á ^ & ç } Á Ë î

MAINTENANCE SECTION

Maintenance Section 4-1

MAINTENANCE

General Instructions

Tiger Mowers are designed for high performance and rugged durability, yet with simplified maintenance. The purpose of this section of the manual is to help the operator in the regular servicing of the mower. Regular maintenance at the intervals mentioned will result in the maximum efficiency and long life of the Tiger Mower.

When you purchase a Tiger Mower you also acquire another valuable asset, Tiger's parts organization. Our rapid and efficient service has guaranteed the customer satisfaction for many years. Tiger parts keep up with the demands for efficiency, safety and endurance expected of the Tiger Mower.

Maintenance Precautions

- Be sure end of grease gun and zerks are clean before using. Debris injected into bearings, etc. with grease will cause immediate damage.
- DO NOT use a power grease gun to lubricate bearings. These require very small and exact amounts of lubrication. Refer to the detailed maintenance section for specific lubrication instructions. DO NOT over-grease bearings.
- Lexan windows should be washed with mild soap or detergent and lukewarm water, using a soft clean sponge or soft cloth. DO NOT use abrasive or alkaline cleaners or metal scrapers on lexan windows!
- Be alert to maintenance indicators such as the in-tank filter pressure gauge, hydraulic reservoir sight gauge, etc. Take the required action to correct any problems immediately.
- Release of energy from pressurized systems may cause inadvertent actuation of cylinders, or sudden release of compressed springs. Before disconnecting any hoses, relieve pressure by shutting tractor off, setting cutter on ground and actuating lift valve handles.

WARNING

DO NOT use hands to check for suspected leaks in hydraulic hoses! Hydraulic fluid escaping under pressure can have sufficient force to penetrate skin and cause serious injury. If fluid is injected into skin, it must be surgically removed within a few hours or gangrene may result. Use a small piece of wood or cardboard, not hands, to search for pin hose leaks. Be sure all connections are tight and hoses and lines are not damaged before applying pressure.

Break in Period

In addition to following the break-in instructions for your particular tractor, the in-tank hydraulic fluid filter should be replaced after the first 50 hours of service. The reafter the filter should be replaced every 500 hours, or yearly, which ever comes first.

Re-torque wheel lugs after first five hours of operation and periodically thereafter. See torque specifications listed in the tractor's service manual for your particular model. **Wheel lugs must always be re-torqued whenever a wheel is removed and reinstalled.**

DANGER

Never work under the Implement, the framework, or any lifted component unless the Implement is securely supported or blocked up to prevent sudden or inadvertent falling which could cause serious injury or even death. (SG-14)



MAINTENANCE



WARNING Do not modify or alter this Implement. Do not permit anyone to modify or alter this Implement, any of its components or any Implement function. (SG-8)



WARNING Relieve hydraulic pressure prior to doing any maintenance or repair work on the Implement. Place the Mower Head on the ground or securely supported on blocks or stands, disengage the PTO, and turn off the engine. Push and pull the control Levers or Joystick several times to relieve pressure prior to starting any maintenance or repair work. (SBM-6)



DANGER Always disconnect the wire leads from the mower pump solenoid before performing service on the Tractor or Mower. Use caution when working on the Tractor or Mower. Tractor engine must be stopped before working on Mower or Tractor. The Mower Blades could inadvertently be turned on without warning and cause immediate dismemberment, injury or death. (SBM-12a)

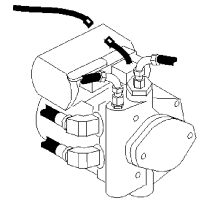

MAINTENANCE

MAINTENANCE

Regular Maintenance

The intervals at which regular servicing should be done are based on hours of operation. Use the tractors hour meter to determine when regular servicing is required.

Refer to the Detailed Maintenance section for further instructions on greasing. Copy and use the Daily Maintenance sheet located at the end of this section.

Daily or Every 8 Hours

ITEM	SERVICE	COMMENTS
Drive Shaft Yoke, U-Joint & Stub Shaft	Grease	Grease as instructed in detailed maintenance section
Pump Drive Shaft Coupler	Check and Lube	Insure driveshaft end play
Crankshaft Adapter	Check rubber grommets	Replace grommets if damaged or missing
Pivot Points	Lubricate	Inject grease until it appears at end
Hydraulic Fittings	Check for leaks	Tighten when needed. Do Not use hands to check for leaks, see maint. precautions
Knives	Check	Inspect for missing or damaged knives, change as needed.
Spindle mounting bolts (spindle to deck)	Check	Torque to 315 ft. lbs. lubricated Torque to 357 ft. lbs. dry
Knife mounting bolts (knife to disk or blade bar)	Check	Pre-lubricate threads with anti-seize torque to 800 ft. lbs.
Disk/Blade Bar mounting bolts (disk/blade bar to spindle)	Check	Torque to 180 ft. lbs. lubricated Torque to 204 ft. lbs. dry
Belts	Check/Adjust	Check if broken, tighten as required
Main Frame and Deck	Check	Retorque bolts to torque specifications in this section
Hydraulic Fluid Level	Check	Add if required per fluid recommendations
Rear Flail Drive(if applicable) Bear Flange and Shaft Coupler	Lubricate	Grease as instructed in detailed maintenance section
Cutter Shaft and Ground Roller	Lubricate	Grease as instructed in detailed maintenance section

Boom

Maintenance Section 4-4

MAINTENANCE

MAINTENANCE

WEEKLY OR EVERY 40 HOURS

ITEM	SERVICE	COMMENTS
Rotary Spindle	Lubricate	Every 40 hours or weekly

WEEKLY OR EVERY 50 HOURS

ITEM	SERVICE	COMMENTS
In Tank Hyd. Fluid Filter 10 micron filter)	Change	Change after first 50 hours only, then every 500 hours or yearly
In-Line High Pressure Filter (10 micron filter)	Change	Change after first 50 hours only, then every 500 hours or yearly

MONTHLY OR EVERY 150 HOURS

ITEM	SERVICE	COMMENTS
Hydraulic Fluid Level	Check	Add as needed
Hyd. Tank Breather	Clean/Check/Replace	Clean or replace element as required
Rear Tire Type	Max P.S.I.	
480/80R38	29	
18.4-34	26	
18.4-38	26	

YEARLY OR EVERY 500 HOURS

ITEM	SERVICE	COMMENTS
Spindle Grease	Change	
Hyd. Tank Fluid	Change	
In Tank Hyd. Fluid Filter (10 micron filter)	Change	
In-Line HP Filter (10 micron filter)	Change or	Change when indicated by restriction indicator.
Hyd. Tank Breather	Change	

MAINTENANCE

TROUBLESHOOTING

SYMPTOMS	CAUSE	REMEDY
Vibration	<ol style="list-style-type: none"> 1. Loose bolts 2. Cutter assembly unbalanced 	<ol style="list-style-type: none"> 1. Check all bolts and tighten to recommended torque specs. 2a. Check for damaged blades, disc or cuttershaft. Replace if needed. 2b. Check for wire, rope, etc. entangled in the cutter assembly
Mower will not lift	<ol style="list-style-type: none"> 1. Hyd. Fluid Low 2. Leaks in line ROU 3. Faulty relief valve 5. Faulty cylinder 	<ol style="list-style-type: none"> 1. Check and refill hyd fluid 2. Tighten or replace fittings and hoses 3. Check pressure in line. Line pressure in control valve should be at least 2500 P.S.I. 5. Inspect, repair or replace cylinder
Mower will not start or run	<ol style="list-style-type: none"> 1. Blown fuse 2. Ball valves closed 3. Low oil level 4. Line leak 5. Electronic solenoid faulty 	<ol style="list-style-type: none"> 1. Check fuse between mower switch and ignition/replace 2. Make sure valves are open 3. Check hyd. tank and fill 4. Check all fittings and lines, re-tighten or replace 5a. Without the tractor running, turn the mower switch to on. A low audible click should be heard if the solenoid is engaging the solenoid spool. If click is not heard, leave switch in on position and with a screwdriver or other steel object, touch the small nut on the end of the solenoid. If the metallic object is not attracted to the nut, check the fuse and wiring for an open circuit. If the object is attracted but no "click" is heard, replace the solenoid. 5b. Remove the four bolts holding the small block to the main block. Lift and remove small block being careful not to damage O-rings/filter. Clean filter and re-install. 5c. Remove large nut on side of large valve block. Remove spring, and use needle nose vise grip to pull spool from block. Check block and spool for contaminants and scratches. Clean parts or replace if scratched.

MAINTENANCE

MAINTENANCE

TROUBLESHOOTING (CONTINUED)





SYMPTOMS	CAUSE	REMEDY
Motor runs but will not cut.	1. Belts 2. Tensioner	1. Inspect belts and pulleys. Replace belts and repair as needed. 2. Adjust tensioner nut flatwasher washer is flush with top of guide.
Mower turns slowly or not at all.	1. Contaminants restricting spool movement in valve body. 2. Suction lines obstructed 3. Low oil level	1. Remove large nut on side of large valve block. Remove spring, and use needle nose vise grip to pull spool from block. Check block and spool for contaminants and scratches. Clean parts or replace if scratched. 2. Check for kinks or obstruction in suction hose. 3. Check hyd. tank level and fill.
Pump will not work	1. Excessive wear on internal parts	1. Disassemble and repair.
Motor will not work	1. Excessive wear on internal parts	1. Disassemble and repair.

NOTE: If flow meter is available, check pressure and flow volume for all suspected hydraulic problems.

If the solution to your problem cannot be found in this section, call the Technical Service representative at the number shown on the front cover of this manual.

MAINTENANCE

MAINTENANCE

Torque for Standard Fasteners													
Nominal Dia. (in.)	threads per inch	 Grade 2			 Grade 5			 Grade 8			 Grade 9		
		Tightening Torque			Tightening Torque			Tightening Torque			Tightening Torque		
		Lubed	Dry Plated	Dry plain	Lubed	Dry Plated	Dry plain	Lubed	Dry Plated	Dry plain	Lubed	Dry Plated	Dry plain
		K = 0.15	K = 0.17	K = 0.20	K = 0.15	K = 0.17	K = 0.20	K = 0.15	K = 0.17	K = 0.20	K = 0.15	K = 0.17	K = 0.20
Unified Coarse Thread Series													
1/4	20	49 in-lbs	59 in-lbs	66 in-lbs	76 in-lbs	86 in-lbs	101 in-lbs	107 in-lbs	122 in-lbs	143 in-lbs	126 in-lbs	143 in-lbs	168 in-lbs
5/16	18	101	122	135	157	178	209	221	251	295	259	294	346
3/8	16	15 ft-lbs	18 ft-lbs	20 ft-lbs	23 ft-lbs	26 ft-lbs	31 ft-lbs	33 ft-lbs	37 ft-lbs	44 ft-lbs	38 ft-lbs	43 ft-lbs	51 ft-lbs
7/16	14	24	29	32	37	42	49	52	59	70	61	70	82
1/2	13	37	44	49	57	64	75	80	90	106	94	106	125
9/16	12	53	63	70	82	92	109	115	130	154	135	153	180
5/8	11	73	87	97	113	128	150	159	180	212	186	211	248
3/4	10	129	155	172	200	227	267	282	320	376	331	375	441
7/8	9	125	150	167	322	365	429	455	515	606	533	604	710
1	8	187	225	250	483	547	644	681	772	909	799	905	1065
1 1/8	7	266	319	354	596	675	794	844	966	1288	1132	1283	1510
1 1/4	7	375	450	500	840	952	1121	1183	1363	1817	1597	1810	2130
1 1/2	6	652	783	869	1462	1657	1950	2051	2371	2688	2317	2779	3150
Fine Thread Series													
1/4	28	56 in-lbs	68 in-lbs	75 in-lbs	87 in-lbs	99 in-lbs	116 in-lbs	123 in-lbs	139 in-lbs	164 in-lbs	144 in-lbs	163 in-lbs	192 in-lbs
5/16	24	112	135	150	174	197	231	245	278	327	287	325	383
3/8	24	17 ft-lbs	20 ft-lbs	23 ft-lbs	26 ft-lbs	30 ft-lbs	35 ft-lbs	37 ft-lbs	42 ft-lbs	49 ft-lbs	43 ft-lbs	49 ft-lbs	58 ft-lbs
7/16	20	27	32	36	41	47	55	58	66	78	68	78	91
1/2	20	41	49	55	64	72	85	90	102	120	105	120	141
9/16	18	59	71	78	91	103	121	128	146	171	151	171	201
5/8	18	82	99	110	127	144	170	180	204	240	211	239	281
3/4	16	144	173	192	223	253	297	315	357	420	369	418	492
7/8	14	138	165	184	355	403	474	502	568	669	588	666	784
1	14	210	252	280	542	614	722	765	867	1020	896	1016	1195
1 1/8	12	298	357	397	668	757	890	1083	1227	1444	1269	1439	1693
1 1/4	12	415	498	553	930	1055	1241	1509	1710	2012	1768	2004	2358
1 1/2	12	734	880	978	1645	1865	2194	2668	3024	3557	3127	3544	4169

Torque values for 1/4 and 5/16-in series are in inch-pounds. All other torque values are in foot-pounds. K = 0.15 for "lubricated" conditions D = Nominal Diameter
 Torque values calculated from formula T=KDF, where K = 0.17 for zinc plated and dry conditions F = Clamp Load
 K = 0.20 for plain and dry conditions

Torque-Tension Relationship for Metric Fasteners													
Nominal Dia. (mm)	Pitch	Class 4.6			Class 8.8			Class 10.9			Class 12.9		
		Tightening Torque			Tightening Torque			Tightening Torque			Tightening Torque		
		Lubed	Dry Plated	Dry plain	Lubed	Dry Plated	Dry plain	Lubed	Dry Plated	Dry plain	Lubed	Dry plain	
		K = 0.15	K = 0.17	K = 0.20	K = 0.15	K = 0.17	K = 0.20	K = 0.15	K = 0.17	K = 0.20	K = 0.15	K = 0.20	
		(ft-lbs)	(ft-lbs)	(ft-lbs)	(ft-lbs)	(ft-lbs)	(ft-lbs)	(ft-lbs)	(ft-lbs)	(ft-lbs)	(ft-lbs)	(ft-lbs)	
3	0.5	0.28	0.32	0.38	0.73	0.82	0.97	1.0	1.2	1.4	1.2	1.6	
3.5	0.6	0.44	0.50	0.59	1.1	1.3	1.5	1.6	1.9	2.2	1.9	2.5	
4	0.7	0.66	0.74	0.87	1.7	1.9	2.3	2.4	2.7	3.2	2.8	3.8	
5	0.8	1.3	1.5	1.8	3.4	3.9	4.5	4.9	5.5	6.5	5.7	7.6	
6	1	2.3	2.6	3.0	5.8	6.6	7.7	8.3	9.4	11	9.7	13	
6	1.25	2.1	2.3	2.7	5.3	6.0	7.0	7.6	8.6	10	8.8	12	
7	1	3.8	4.3	5.0	9.7	11	13	14	16	19	16	22	
8	1	5.9	6.6	7.8	15	17	20	22	24	29	25	34	
8	1.25	5.5	6.2	7.3	14	16	19	20	23	27	24	31	
10	1.25	11	13	15	29	33	39	42	48	56	49	66	
10	1.5	11	12	14	28	32	37	40	45	53	47	62	
12	1.25	21	23	28	53	60	71	76	86	101	89	119	
12	1.5	20	22	26	51	58	68	73	82	97	85	113	
12	1.75	19	21	25	49	55	65	70	79	93	81	108	
14	1.25	26	29	34	66	75	89	95	108	127	111	148	
14	1.5	28	32	37	72	82	96	103	117	138	121	161	
14	2	30	34	40	78	88	104	111	126	148	130	173	
16	1.5	50	57	67	129	146	171	184	208	245	215	287	
16	2	47	53	62	121	137	161	173	196	230	202	269	
18	1.5	73	82	97	187	212	249	268	303	357	313	417	
18	2.5	65	73	86	167	189	222	239	270	318	279	372	
20	1.5	101	115	135	270	306	360	374	424	498	437	583	
20	2.5	91	104	122	236	267	314	337	382	449	394	525	

Clamp load calculated as 75% of the proof load for specified bolts. K = 0.15 for "lubricated" conditions D = Nominal Diameter
 All torque values are listed in foot-pounds K = 0.17 for zinc plated, dry conditions F = Clamp Load
 Torque values calculated from formula T=KDF, where K = 0.20 for plain and dry conditions

MAINTENANCE

LUBRICATION RECOMMENDATIONS

MAINTENANCE

Description	Application	General Specification	Recomended Mobil Lubricant
Tractor Hydraulics	Reservoir	JD-20C MF M1135,M1141 FNHM2C134D (FNH201)	Mobilfluid 424
Mower Hydraulics Cold Temperatures 0° F Start-Up	Reservoir	ISO 46 Anti-Wear-Low Temp	Mobil DTE 15M
Normal Temperatures 10° F Start-Up		JD-20C MF M1135,M1141 FNH M2C134D(FNH201)	Mobilfluid 424
Normal Temperatures 15° F Start Up		ISO 46 Anti-Wear	Mobil DTE 25
High Operating Temp. Above 90° F		ISO 100 Anti-Wear	Mobil DTE 18M
Flail Rear Gearbox	Grease	PAO Synthetic Extreme Pressure Gear Lube	Mobil SHC 75W-90 Mobil 1 Synthetic Gear
Cutter Shaft & Ground Roller Shaft(Flail)	Grease Gun	Lithium-Complex Extreme Pressure NLGI-ISO 320	Mobilgrease CM-S
Drive Shaft Coupler (Flail and Rotary)	Grease Gun	Lithium-Complex Extreme Pressure NLGI2-ISO 320	Mobilgrease CM-S
Drive Shaft Yoke, U-joint & Stub Shaft	Grease Gun	Lithium-Complex Extreme Pressure NLGI2-ISO 320	Mobilgrease CM-S
Boom Swivel Boom Cylinder Pivots (Rotary & Flail Boom)	Grease Gun	Lithium Complex Extreme pressure NLGI2-ISO 320	Mobilgrease CM-S
Deck Boom Pivot & Deck Stop Adjustment Rotary & Flail)	Grease Gun	Lithium Complex Extreme Pressure NLGI-ISO 320	Mobilgrease CM-S
Deck Spindle(Rotary)	Grease Gun	Tiger Spindle Lubricant part number 06540000	Mobilith SHC 220

Boom

Maintenance Section 4-9

MAINTENANCE

POLYCARBONATE CARE AND MAINTENANCE

The propriety UV and Abrasion Resistant Surface coating on SHIELDS SUPERCOATED polycarbonate significantly improves performance. Periodic cleaning using proper procedures and compatible cleaners are recommended to prolong service life. Tiger Corp. polycarbonate is SUPERCOATED on both sides.

CLEANING THE SUPERCOAT HARD-COAT

1. Wash with a mild solution of soap or detergent and lukewarm water.
2. Using a soft cloth or sponge, gently wash the sheet to loosen dirt and grime and rinse well with clean water.
3. To prevent water spotting, thoroughly dry with chamois or cellulose sponge.
4. Avoid the use of abrasive cleaners, squeegees and/or other cleaning implements that may mar or gouge the coating.

CLEANING AGENTS WHICH HAVE BEEN FOUND TO BE COMPATIBLE UNDER LABORATORY CONDITIONS:

Aqueous Solutions of Soaps and Detergents

Windex(1)	Top Job(2)	Joy(2)	Mr Clean(2)
Fantastik(3)	Formula 409(4)	Sumalight D12	Brucodecid

Organic Solvents

Butyl Cellosolve	Kerosene	Hexel, F.O. 554	Naphtha(VM&P grade)
Neleco-Placer	Turco 5042		

Alcohols

Methanol	Isopropyl
----------	-----------

All residual organic solvents should be removed with a secondary rinse.

GRAFFITI REMOVAL

Butyl cellosolve (for removal of paints, marking pen inks, lipstick, etc.) The use of masking tape, adhesive tape or lint removal tools work well for lifting off old weathered paints.

To remove labels, stickers, etc., the use of kerosene or VM&P naphtha is generally effective. When the solvent will not penetrate sticker material, apply heat (hair dryer) to soften the adhesive and promote removal.

IMPORTANT: If a material is found to be incompatible in a short-term test, it will usually be found to be incompatible in the field. The converse, however, is not always true. Favorable performance is no guarantee that actual end-use conditions have been duplicated. Therefore, these results should be used as a guide only and it is recommended that the user test the products under actual end-use conditions.

MAINTENANCE

MAINTENANCE

RECOMMENDED FILLING INSTRUCTIONS FOR HYDRAULIC RESERVOIRS

When filling or checking the oil level, the unit should be parked on a level surface, shut OFF, and allow sufficient time to cool to ambient temperature. Use caution when removing the pressurized breather. Do not place face over opening when removing breather.

If your reservoir has two sight glasses: The reservoir should be filled to the top of the lower sight glass on the side of the tank. Do not overfill. The reservoir has been overfilled when oil is visible in the upper sight glass. If tank has too much oil, the excess may be expelled through the pressurized breather.

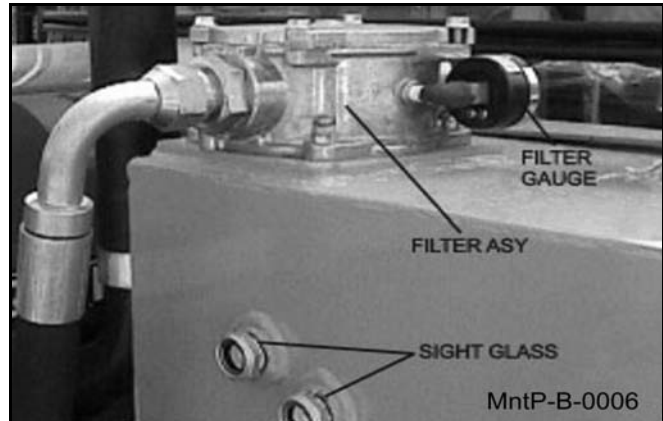

If your reservoir has one sight glass/temperature gage: The reservoir should be filled to the center of the sight glass on the side of the tank. Do not over-fill. If the tank has too much oil, the excess may be expelled through the pressurized breather.

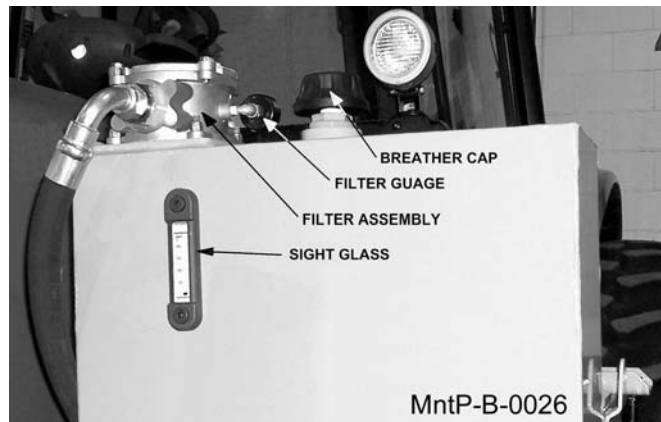

DETAILED MAINTENANCE

REPLACING IN-TANK HYDRAULIC FILTER:

Loosen the four bolts on the top cover of the filter housing. Turn cover counter-clockwise until cover is free. Remove and replace filter. Replace top cover and cover bolts in opposite order as removed.



MAINTENANCE

MAINTENANCE

DETAILED MAINTENANCE

REPLACING HIGH PRESSURE HYDRAULIC FILTER ELEMENT:

Ensure that the system has been shut down and de-pressurized. Locate High Pressure Filter housing. Confirm that the element that is about to be installed matches the element p/n on the filter model tag. *Example: V3.0510-06 (world line 100, HD049 model)* Locate the bottom of the High Pressure Bowl. Using the appropriate spanner wrench or ratchet, turn in a counter clockwise rotation, (looking at the bottom of the bowl) to remove the bowl from the head. The first couple of rotations will seem tight as the o-ring passes the sealing flats. Once the o-ring has cleared the sealing flats the bowl should spin freely. Taking care not to drop the bowl, finish removing the bowl from the head. **WARNING: bowl will be full of oil!**

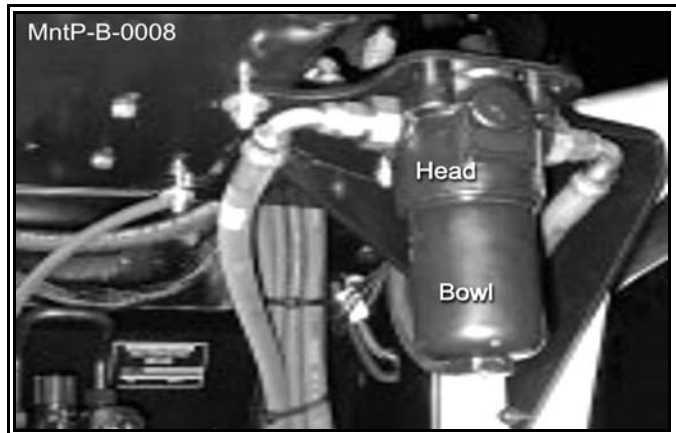

Pour the oil from the bowl into a container. This oil should be considered contaminated because the flow direction through the element is outside-in. Clean the inside of the bowl if "dirt" is present. Remove the old element from the filter head by pulling with a rotation motion. Dispose of the used element properly. Remove the new element from the packaging. Using your finger, dab and lubricate the o-ring in the top of the new element with oil. Install the new element into and on the mounting boss within the head. Ensure that the element is fully seated on the boss. Clean and inspect the o-ring that is affixed in the bowl and lubricate with oil. Using a clockwise rotation, screw the bowl back into the head, ensuring that the bowl has not been cross threaded into the head. Continue to tighten the bowl into the head, using the spanner wrench or ratchet. The rotation of the bowl will become tighter once the o-ring engages the sealing flats. Once the bowl has bottomed out, back-off the bowl by 1/6 turn. This ensures that the o-ring is seated properly within the sealing flats. Element change out and re-assembly is now complete. Start the machine and inspect the filter area, checking that there is no oil leaking from the filter assembly. Replace the filter element first at 50 hours of operation, then yearly (500 hours) or when indicated by restriction indicator.

GREASING CUTTERSHAFT -- FLAIL MOWERS

Locate grease zerks on each end of cuttershaft(s), these are located on the bearing cover. Normal conditions require one or two pumps in each bearing, using Lithium-Complex Extreme Pressure grease conforming to NLGI2-ISO 320 specifications. This is to be done with a standard grease gun daily or at **8 hour intervals**. **CAUTION: Over greasing may cause premature seal failure.**

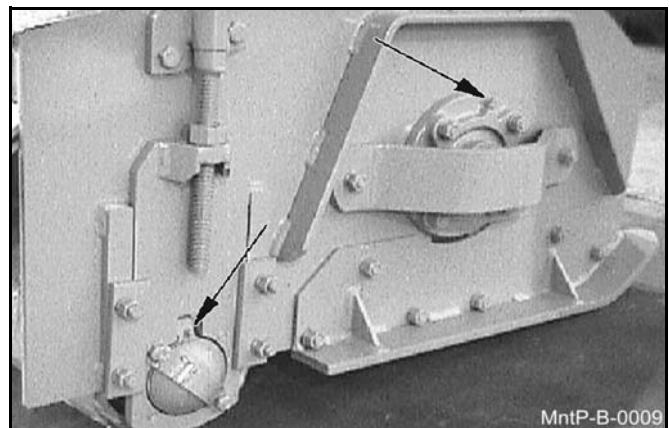

MAINTENANCE

MAINTENANCE

GREASING GROUND ROLLER SHAFT-- FLAIL

Locate grease zerks on each end of roller tube at lower end of head. Normal conditions require one or two pumps in each bearing, using Lithium-Complex Extreme Pressure grease conforming to NLGI2-ISO 320 specifications. This is to be done with a standard grease gun daily or at **8 hour intervals**. **CAUTION: Over greasing may cause premature seal failure.**



ADJUSTING/CHECKING BELT TENSION

To adjust belt tension or replace belts on flail cutter head, remove four bolts that secure the belt cover and remove cover. The hex nuts shown below can be adjusted to increase/decrease the belt tension as needed. (NOTE: Location of adjustment nuts may vary on flail cutter heads.) **Be sure to replace the belt cover BEFORE operating mower!**

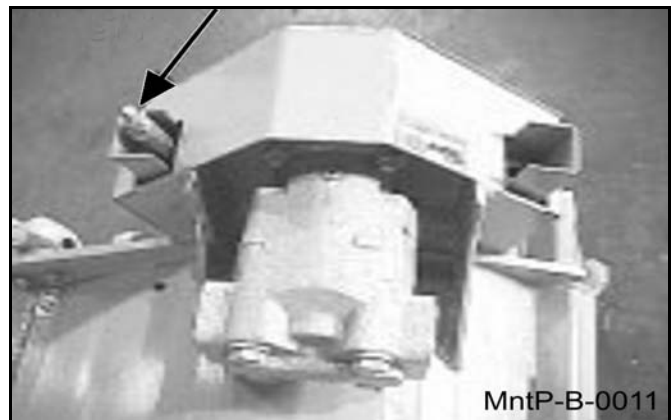

TIGHTENING KNIFE BOLTS AND DISK BOLTS:

After every 8 hours of operation or daily, the Knife Bolts and disk bolts should be tightened as follows:

Knife mounting bolts torque to 800 lubricated ft. lbs.

Disk mounting bolts (6ea.) torque to 204 dry or 180 lubricated ft. lbs.

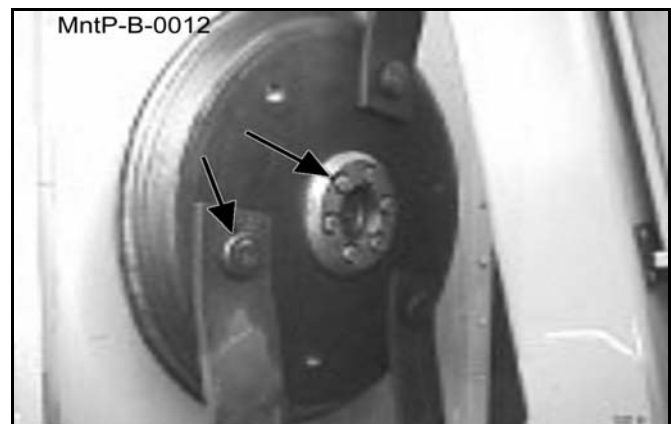

MAINTENANCE

MAINTENANCE

GREASING POINTS ON BOOM AND PIVOT

Locate grease zerks on deck pivot assembly, on the deck end of secondary boom, at main/secondary boom joint, and at swivel end of main boom. Inject Lithium-Complex Extreme Pressure grease conforming to NLGI2 -ISO 320 specifications until grease begins to protrude from ends.

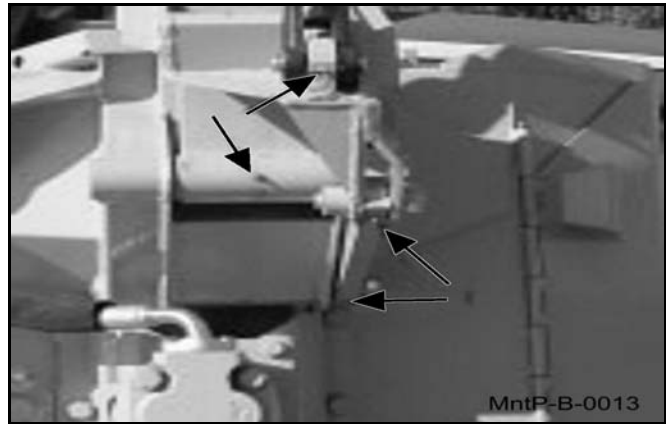

DECK STOP ADJUSTMENT

On boom flail, loosen locking nut. Turn adjustment bolt in, and run deck cylinder out to full extension. Adjust bolt out until the head just touches the boom, and tighten lock nut. **NOTE: Bolt should not hit boom before cylinder reaches full travel.**



GREASING SPINDLE

Locate grease fitting on inside of deck housing. Inject Tiger Spindle Lubricant, part number 06540000 into spindle housing. Fill with lubricant until lubricant weeps out of top spindle seal. Lubricate spindle weekly or every 40 hours of use.



MAINTENANCE

TIGHTENING SPINDLE BOLTS

The spindle mounting bolts should be checked and retorqued daily or every 8 hours of service. Torque the (6) bolts shown below to 357 dry or 315 ft. lbs. lubricated.

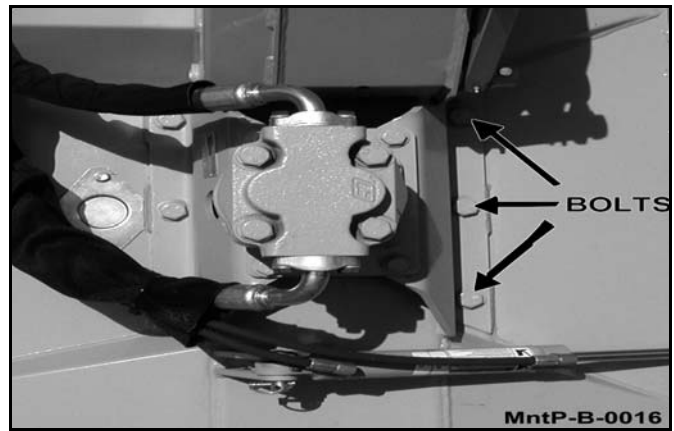

GREASING PUMP DRIVE SHAFT COUPLER

With engine stopped, ensure driveshaft alignment by grasping coupler and sliding back and forth. Coupler should slide freely with approximately 1/8" of end play. If coupler does not slide freely, inspect for loose pump mount bolts, or damaged or loose crankshaft adapter. Inject Lithium-Complex Extreme Pressure grease conforming to NLG12-ISO 320 specifications into coupler until grease begins to protrude from ends. Grease daily or every 8 hours. Do not over grease.



MAINTENANCE

MAINTENANCE

DRIVESHAFT YOKE, U-JOINT STUB SHAFT

With engine stopped, inject Lithium-Complex extreme pressure grease conforming to NLGI2-ISO 320 specifications into universal joints and slip yoke until grease appears at the seal. Grease them daily or every 8 hours.

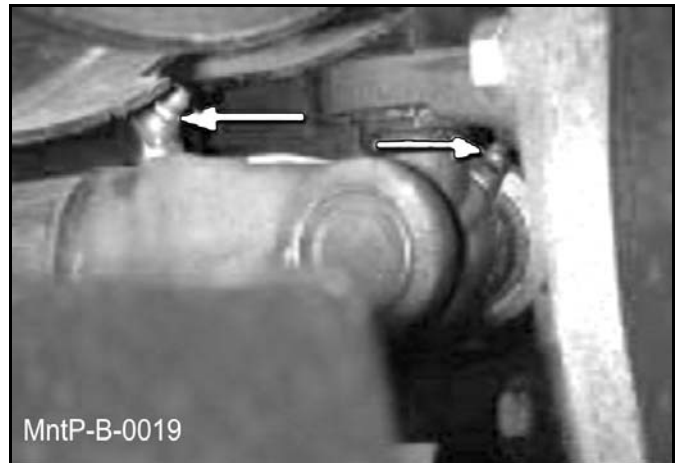
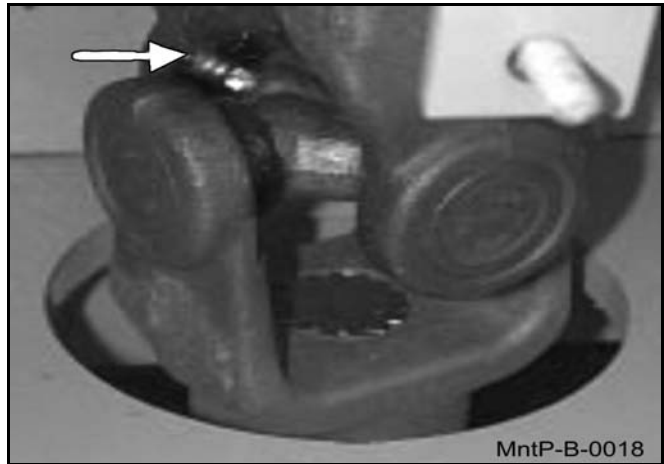

GREASING THE BOOM SWIVEL

Locate the zerks on the main swivel boss (if applicable), main boom pivot boss (if applicable) and on both ends of the boom swivel cylinder. Inject Lithium-Complex Extreme Pressure grease conforming to NLGI2-ISO 320 specification until grease begins to protrude from ends.

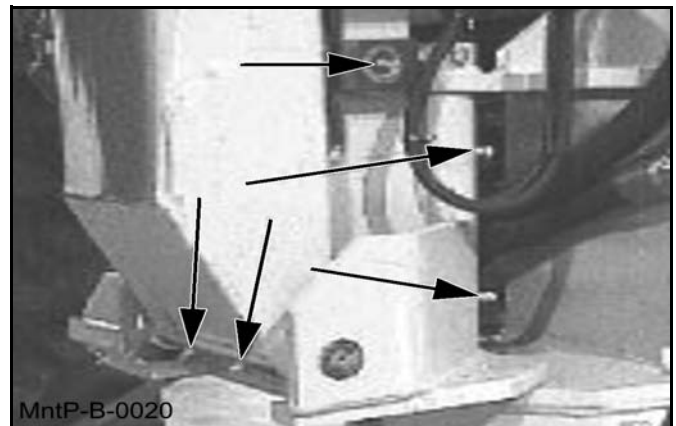

MAINTENANCE

MAINTENANCE

GREASING BOOM CYLINDER(S) PIVOT POINTS

Locate the zerk on the butt end tang of cylinder and on rod end tang. Inject Lithium-Complex Extreme Pressure grease conforming to NLGI2-ISO 320 specifications until grease begins to protrude from ends. This procedure is to be used on the main boom cylinder, secondary boom cylinder, deck pivot, and swivel cylinders daily or at 8 hour intervals.

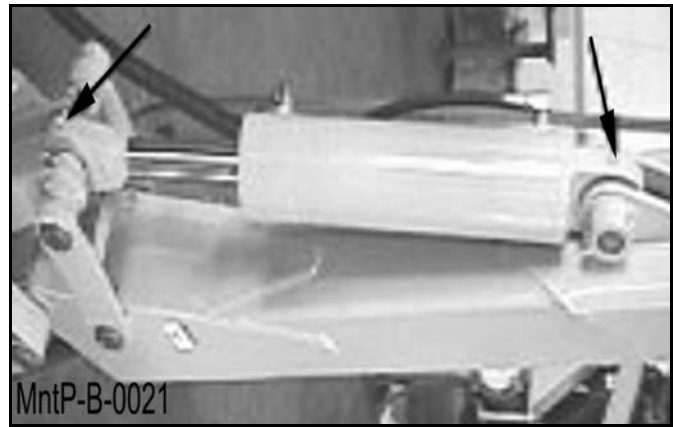

BALL VALVES

The ball valve at the hydraulic reservoir may need to be closed during certain maintenance or repair procedures. **THE BALL VALVES MUST BE OPEN (handle parallel with valve) WHEN TRACTOR IS RE-STARTED OR PUMP IS COUPLED TO MOTOR OR PTO!** Failure to do so will result in component failure!

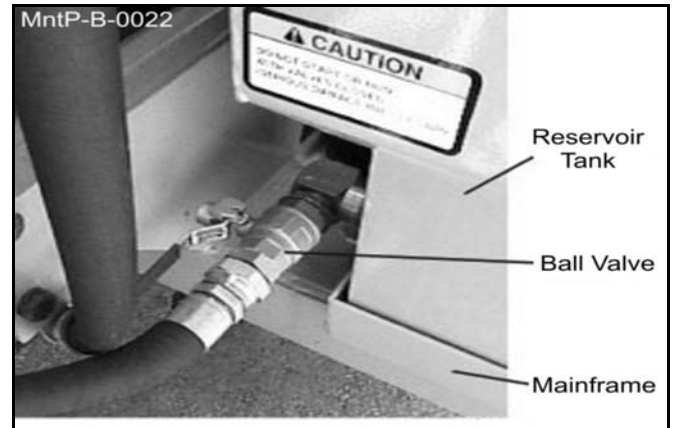

MAINTENANCE

Blades

Check the Blades for cracks and wear and Blade Bolts for tightness, daily. Blades should be replaced when they are worn excessively, bent, deformed, or out of balance.

CAUTION

Blades should always be replaced in pairs. Blades of different weights can cause serious imbalance and damage to the machine and personnel. When replacing blades, take care to replace the blade bolts, nuts, and washers.

Important

Make sure the mower blades are turning clockwise when looking down from the top of the mower. Follow the color coding on the hydraulic hoses and fittings to make sure the motor and hydraulics hoses are assembled properly. Connect the red hose connection only to red fitting. Connect the blue hose connection only to the blue fitting. The blade rotation on the leading edge of the mower should discharge the cut material away from the tractor and operator.

WARNING

If the leading edge of the mower blades are rotating backwards they can discharge material toward the operator. If this occurs discontinue mowing immediately and reverse the direction of the motor rotation by correctly installing the motor pressure and return hoses. Contact your dealer or Alamo Industrial for specific information on the hose routing.

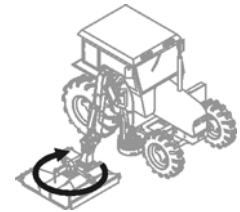

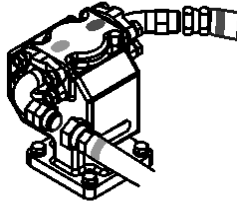
WARNING	ADVERTENCIA
TO AVOID SERIOUS INJURY AND DEATH FROM THROWN OBJECTS: <ul style="list-style-type: none">● MAKE CERTAIN blades rotate the correct direction.	PARA EVITAR LESION SERIA O MUERTE POR OBJETOS LANZADOS: <ul style="list-style-type: none">● ASEGURE que las cuchillas giran en la dirección correcta.
BLADE ROTATION  ROTACIÓN DE CUCHILLAS	
Return Retorno BLUE	 Pressure Presión RED

D619

MAINTENANCE

ROTARY KNIFE REPLACEMENT

1. Be sure you have a complete matching set of new knives for replacement.
2. Remove knives and inspect holes for damage. Also watch for cracks in the disk (if applicable) around the holes.
3. Lube threads with anti-seize. Install bolts through knife and disk from bottom side of disk/blade bar. Install new self-locking nuts and torque them to 800 ft. lbs.
4. The knives should swing freely to absorb shocks from impact when striking objects.



WHEN CUTTING HEAVY BRUSH, KNIFE BOLTS SHOULD BE INSPECTED HOURLY AND RETORQUED TO 800 LUBRICATED FT. LBS.

REPLACEMENT OF ROTARY DISK/BLADE BAR



Failure to follow the following warnings and instructions may result in serious injury or damage to the equipment or property!

1. The bolts that attach the disk to the spindle must be grade 8. These 5/8 inch bolts are to be torqued to 204 dry or 184 ft. lbs lubricated with Loctite 271.
2. A thread locking agent may be applied to threads of all mounting bolts before they are installed.
3. **Disks must be inspected daily for hairline cracks between spindle mounting bolts or around the knife mounting bolts. These cracks indicate metal fatigue caused by severe abuse. If cracks are present the disk must be replaced.**
4. Inspect the disk mounting bolts daily when checking tightness of knife mounting bolts. If a disk mounting bolt is loose, it must be removed, threads cleaned, fresh thread locking agent applied, and tightened to proper torque value.
5. If a knife mounting bolt is loose, the self locking nut must be replaced as a safety precaution. Lubricate threads with anti-seize. Install bolts through knife and disk/blade bar from bottom side. Install self locking nuts and torque them to 800 ft. lbs.

MAINTENANCE

Flail Blades Inspection



Inspect the Blades daily for abnormal wear. REPLACE ALL BLADES on the carrier IMMEDIATELY if any blades have:

- Become bent or deformed from its original shape, or
- Wear inside the blade bolt hole, or
- Any cracks are visible, or
- Deep gouges in the blade's surface are present, or
- Gouges or chipped areas in the cutting edge are larger than 1/4"(8mm), or
- The material on the leading edge has been worn away by more than 1/4"(8mm)

DO NOT straighten, sharpen, weld or hard-face blades

Failure to replace worn or damaged blades may lead to catastrophic failure of the blades and ejection of the broken part with tremendous force which may cause serious bodily injury or death.

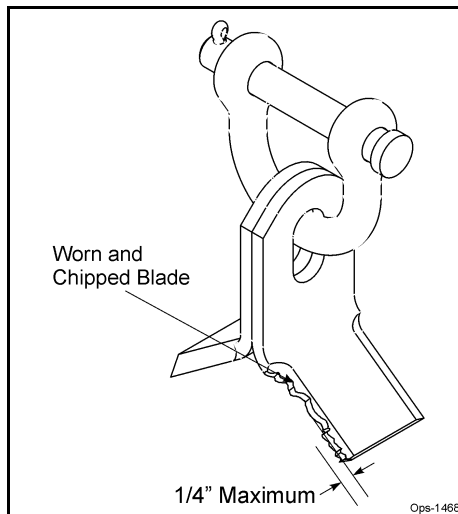

Always replace blades in sets

- Blades that are damaged may indicate severe service or abuse. If one blade is worn or damaged other blades on the same shaft will have been subjected to the same severe service or abuse.
- The Flail rotor turns at speeds exceeding 2000 RPM and is dynamically balanced at the factory. Differences in blade weight between used blades with loss of material from gouges or wear as compared to new blades can cause severe vibration and damage to the Flail rotor. Always replace blades as complete sets.

MAINTENANCE

Blade Pins and D-Ring Inspection

Inspect Blade Pins and D-Rings daily for wear or damage as follows:



Inspect the Blade pins and D-Rings daily for abnormal wear. Make sure the cotter pins are in place and properly spread. REPLACE BLADE Pins and D-Rings IMMEDIATELY if they have:

- Visible cracks or
- If a Pin or D-Ring has visible worn areas, or
- If a Pin or D-Ring has gouges or chipped areas

Failure to replace abnormally worn pins or D-Rings may lead to catastrophic failure and ejection of the broken part, which may cause serious bodily injury or death.

Always replace the pins and D-Rings whenever excessive wear is noticed.

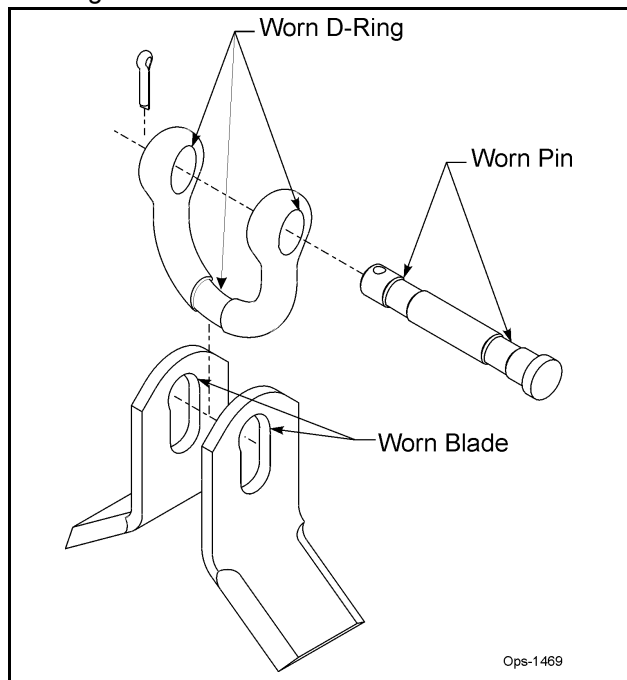

Important

If the cotter pins are broken by contact with other flail blades, remove the pin and reverse the direction the pin is inserted through the D-Ring so that the cotter pin is on the opposite side of the D-Ring. This will prevent the next set of blades from swinging back and hitting the cotter pin. OPS-U-0045

MAINTENANCE

MAINTENANCE

Flail Axe Blades Inspection



Inspect the Blades daily for ab normal wear. REPLACE ALL BLADES on the carrier IMMEDIATELY if any blades have:

- Become bent or deformed from its original shape, or
- Oval shape wear inside the blade bolt hole, or
- Any cracks are visible, or
- Deep gouges in the blade's surface are present, or
- Gouges or chipped areas in the cutting edge are larger than 1/4"(8mm), or
- The material on the leading edge has been worn away by more than 1/4"(8mm)

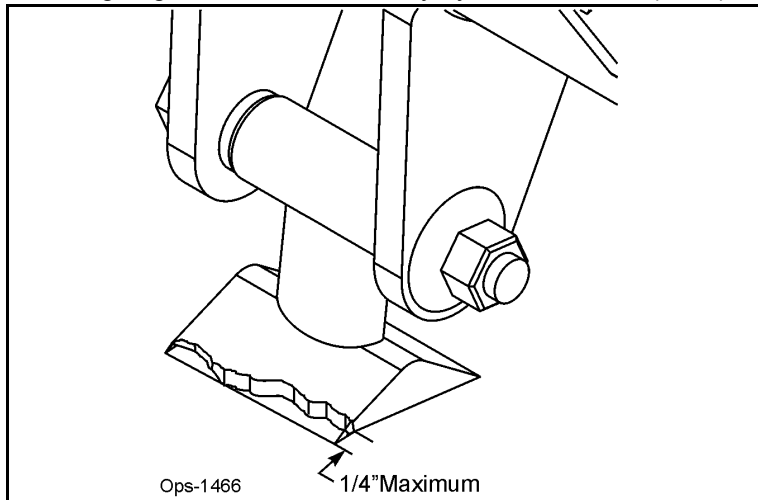

Failure to replace worn or damaged blades may lead to catastrophic failure of the blades and ejection of the broken part with tremendous force which may cause serious bodily injury or death.

Always replace blades in sets

- Blades that are damaged may indicate severe service or abuse. If one blade is worn or damaged other blades on the same shaft will have been subjected to the same severe service or abuse.
- The Flail Axe rotor turns at speeds exceeding 2000 RPM and is dynamically balanced at the factory. Differences in blade weight between used blades with loss of material from gouges or wear, as compared to new blades, can cause severe vibration and damage to the Flail Axe rotor. Always replace blades as complete sets.

Important

Use only genuine Alamo Industrial replacement blades, blade bolts and fasteners. Other blades and bolts may not meet the requirements of Alamo Industrial and may fail during operation, resulting in the part failing and being thrown out from under the mower.



Never attempt to sharpen blades. OPS-U-0042

MAINTENANCE

Flail Axe Blade Bolt Inspection

Inspect Blade Bolts daily for wear or damage as follows:



Inspect the Blade Bolt daily for abnormal wear. REPLACE ALL BLADE BOLTS on the carrier IMMEDIATELY if any bolts have:

- Visible cracks or
- If the blade bolt is worn or any recessed area is visible on the bolt, or
- If Blade Bolt has gouges or chipped areas. or
- If Bushing fits loose in the Rotor Shaft.

Failure to replace abnormally worn bolts or bushings may lead to catastrophic failure of the blades and ejection of the broken part, which may cause serious bodily injury or death.

Always replace Blade Bolts with new bolts and new bushings whenever replacing the Blades. To tighten bolts and nuts, first apply thread lock to nut. Make sure to tighten bolts and nuts just enough to allow the blades to swing freely and not bend the cuttershaft lugs. If cuttershaft lugs are bent together because of over tightening the blades will not swing freely. OPS-U-0043

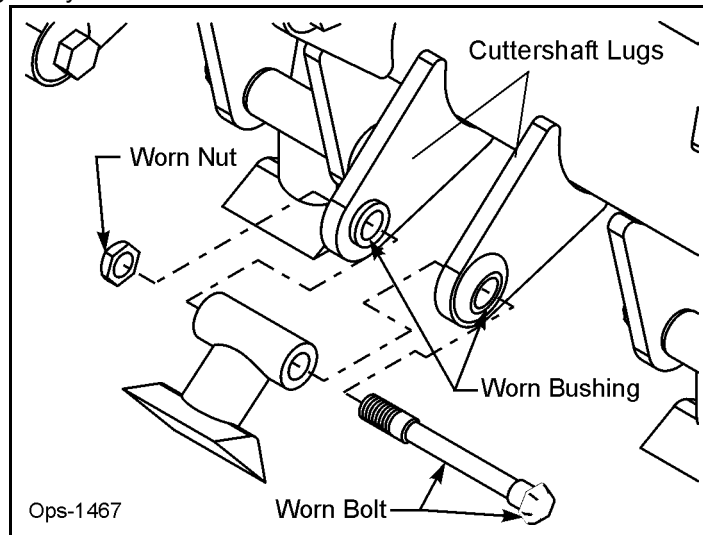

MAINTENANCE

50" FLAIL KNIFE BLADE REPLACEMENT

1. If knives are damaged or badly worn, they will need to be replaced as a set. Replacing a single knife can cause severe vibration and possible damage to the mower. The knife should not be welded on for any reason.
2. Always replace the knife bolts when replacing the knives. DO NOT REUSE THE KNIFE BOLTS OR NUTS.
3. Assemble knives, bushings, bolts and nuts as shown in part section of the manual.
4. Install the locking hex nut so that the flat face of the nut is towards the knife.
5. Apply Loctite 271 or equivalent to threads.
6. Torque nut to 50 ft. lbs. Knife must swing freely.



DO NOT re-use the locking hex nuts for mounting the knives. If hex nut becomes loose, or required removal for knife replacement or any other reason, they must be discarded and replaced with new nuts.

63" BOOM FLAIL KNIFE REPLACEMENT

1. If knives are damaged or badly worn, they will need to be replaced as a set. Replacing a single knife can cause severe vibration and possible damage to the mower.
2. Assemble knives, clevis, bolts and nuts as shown in part section of manual.
3. Install locking hex nut so that the flat face of nut is towards the knife.
4. Apply Loctite 271 or equivalent to threads.
5. Torque nut to 35 FT. LBS. Knife must swing freely.



DO NOT re-use the locking hex nuts for mounting the knives. If hex nut become loose, or require removal for knife replacement or any other reason, they must be discarded and replaced with new nuts.



Knives should not be welded on for any reason.

HEAVY DUTY SPINDLE ASSEMBLY INSTALLATION AND BEARING ADJUSTMENT

WARNING! A press MUST be used to install bearing cups, bearing cones, and seals. DO NOT use a hammer to install races, bearings, or seals. The parts of assembly may be damaged.

NOTE: The grease zerk and gussets are located on the top side of the spindle housing. Be sure the spindle is assembled correctly.

Be sure to wear eye protection and other protective equipment as needed when working on spindle assembly.

MAINTENANCE

MAINTENANCE

THE SPINDLE ASSEMBLY

See the diagram below for identification of spindle parts, while servicing.

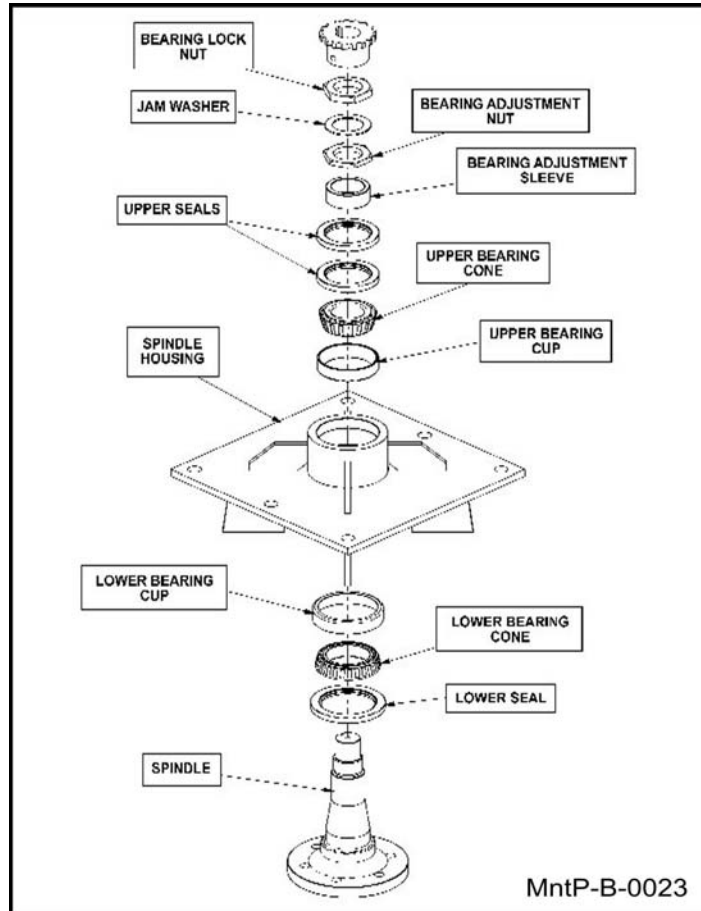

MAINTENANCE

BEARING INSTALLATION

1. Press upper bearing cup in to the spindle housing.
2. Turn the spindle housing over and press in the lower bearing cup.
3. Place the lower bearing cone in the bearing cup. Next press the seal into the spindle housing. The inner lip of the seal must be DOWN, towards the bearing, so lubricant is sealed inside the housing.
4. Install the spindle in the housing. Lightly press the spindle to seat the cone onto the spindle.
5. Support the bottom of the spindle and press the upper bearing cone and bearing adjustment sleeve onto the spindle.
6. **NOTE: The spindle housing must turn freely when seating the bearing cone and sleeve.**
7. Press the two upper seals into the spindle housing. The inner lip of the seals must be UP, away from the bearing, so excess lubricant can escape.
8. Install the bearing adjustment nut (thin nut) so there is 1-1/6" clearance between the nut and the sleeve. Install the jam washer, placing the tab into the key-way. Install the bearing lock nut (thin nut) and hand tighten against jam washer and adjustment nut. See the following section for bearing adjustment.
9. Position the spindle housing horizontally with the drain hole oriented "up". Grease through the zerk with Tiger Spindle Lubricant (part number 06540000) until the grease purges from the drain hole.
10. Install the plug into the drain hole.

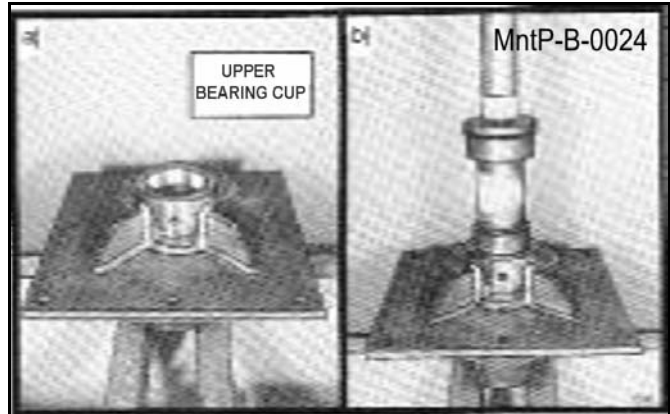

BEARING ADJUSTMENT

1. Clamp the bottom end of the spindle housing securely in a vise so the spindle housing turns freely.
2. Position a magnetic base dial indicator on the outer diameter of the spindle housing. Locate the end of the dial indicator against the flat end of the spindle shaft. The dial indicator will now measure accurately bearing end play.
3. Tighten the bearing adjustment nut until there is .012 inch movement when the spindle housing is pried upward away from the vise jaws.
4. When there is .012 inch free play between the spindle and housing, install the bearing lock nut (thick nut). Hold the adjusting nut securely and tighten the lock nut to 300 ft. lbs. of torque.
5. After the lock nut is tightened, there must be .001 inch to .003 inch of free play when lightly prying up on the spindle housing.

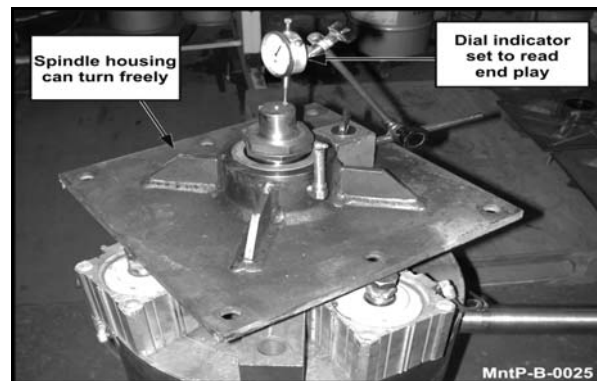

If the end play is correct, .001 inch to .003 inch, bend tabs up on jam washer to prevent the lock nut from loosening.

If the end play is NOT correct, loosen the lock nut and turn the adjustment nut as required and re-tighten the lock nut. Repeat first part of step 5.

MAINTENANCE

Boom Cylinder Removal and Replacement Instructions

1. Clear the area of all personnel before lowering the boom mower head.
2. From the tractor seat with your seat belt fastened around you, lower the boom mower head to the ground. Extend the boom to the furthest reach and lower the mower head flat on the ground. DO NOT attempt to replace the cylinders with the boom in the raised or transport position.
3. Shut off the tractor, engage the parking brake, place the tractor transmission in the park position, and remove the key before dismounting.
4. Allow the system to cool to room temperature before removing any hydraulic components
5. Wear safety glasses and impenetrable gloves when working with hydraulic hoses and fittings.
6. Release all oil pressure from the hydraulic circuit by manually stroking each valve section with the tractor engine off. Utilize the manual override function if the unit is equipped with an electric over hydraulic valve.
7. Utilize blocks, jack stands or a suitable over head hoist to support the weight of the boom section and remove pressure from the cylinder mounting pins.
8. Check to see that the cylinder to be replaced is not under pressure by moving the cylinder pins by hand. The pins should be loose and should slide from the pin bore easily. If the pins are tight and cannot be moved, the cylinder may be under pressure. Make sure the boom components are properly supported and that the pressure is relieved from the circuit.
9. Cylinder assemblies are heavy and can fall when the pins are removed. Support the hydraulic cylinder with a suitable hoist or jack.
10. Slowly loosen the hydraulic connections to the cylinder. Carefully unscrew hose fitting and allow any remaining pressure to bleed off. **Use extreme care.** Oil must be cool, and the technician should stand to the side to prevent exposure to any hydraulic oil. Always consult the Material Safety Data Sheet and wear any required Personal Protective Equipment. A catch pan may be required to retain any spilled oil.
11. Cap both ends of the fitting with suitably sized metal caps.
12. Remove the cylinder pins starting with the ROD end cylinder pin. Make sure the cylinder is properly supported, and remove the base end cylinder pin. The cylinder may be heavy-- use proper lifting techniques to lift and handle the cylinder. If needed, get assistance from another person to safely lift the cylinder from the machine.
13. Measure the distance between the cylinder pin holes and extend the new cylinder the correct length prior to attempting an installation.
14. Install the new cylinder in place and install both cylinder pins and retaining hardware.
15. Remove the metal caps and re-install the hydraulic hoses.
16. Check the hydraulic reservoir of the boom mower to ensure there is sufficient oil. Follow the manufacturer's recommendations for proper oil type and filtering techniques and requirements to add oil to the system.
17. Clear the area of all persons prior to starting the tractor.
18. Consult the Operator's Manual for instructions in regard to the proper operating procedure.
19. From the tractor seat, with the seat belt fastened, operate the boom to ensure proper operation of the boom function.
20. From the tractor seat, with the seat belt fastened, operate the boom controls to fully extend and retract the new cylinder several times to purge any trapped air from the system.
21. From the tractor seat, with the seat belt fastened, look for signs of an oil leak. If an oil leak is observed, shut the tractor down and follow the steps to remove pressure from the hydraulic circuit. Identify the source of the leak and resolve the issue.
22. Upon completion of the required repairs return to Step # 16 to recheck the cylinder for proper operation.

MAINTENANCE

CUTTERSHAFT BEARING REPLACEMENT

1. Remove existing cuttershaft, bearings and string guards.
2. Make sure that the end knives on each end of the cuttershaft are oriented as shown.
3. Apply anti-seize on cuttershaft as shown on next page.
4. Install non-drive side bearing first.
5. Install the top of the string guard on the non-drive side first. Use Loctite 271 or equivalent and torque (95 ft-lb or 104ft-lb if you use an extension).
6. Install the bearing and top string guard on the drive side.
7. Center the cuttershaft between the string guards. Use Loctite 271 or equivalent and torque (95ft-lb or 104ft-lb if you use an extension) the top string guard on the drive side.
8. Install, use Loctite 271 or equivalent, and torque (95ft-lb or 104ft-lb if you use an extension) the bottom string guard on both sides.
9. Make sure the cuttershaft is centered. On the non-drive side, tighten one set screw in the bearing onto the cuttershaft.
10. Remove the other set screw and drill a 5/16" hole into the cuttershaft 3/16" deep through the hole in the bearing. BE CAREFUL NOT TO DAMAGE THE THREADS IN THE BEARING HOLE.
11. Replace the set screw in the bearing, use Loctite 271 or equivalent, and tighten onto the cuttershaft through the new hole.
12. Remove the other set screw and repeat the drilling procedure (Step 10). Replace the set screw as stated in Step 11.
13. Repeat steps 9 through 12 on the drive side.
14. Grease both bearings properly.

See illustration on next page

MAINTENANCE

MAINTENANCE

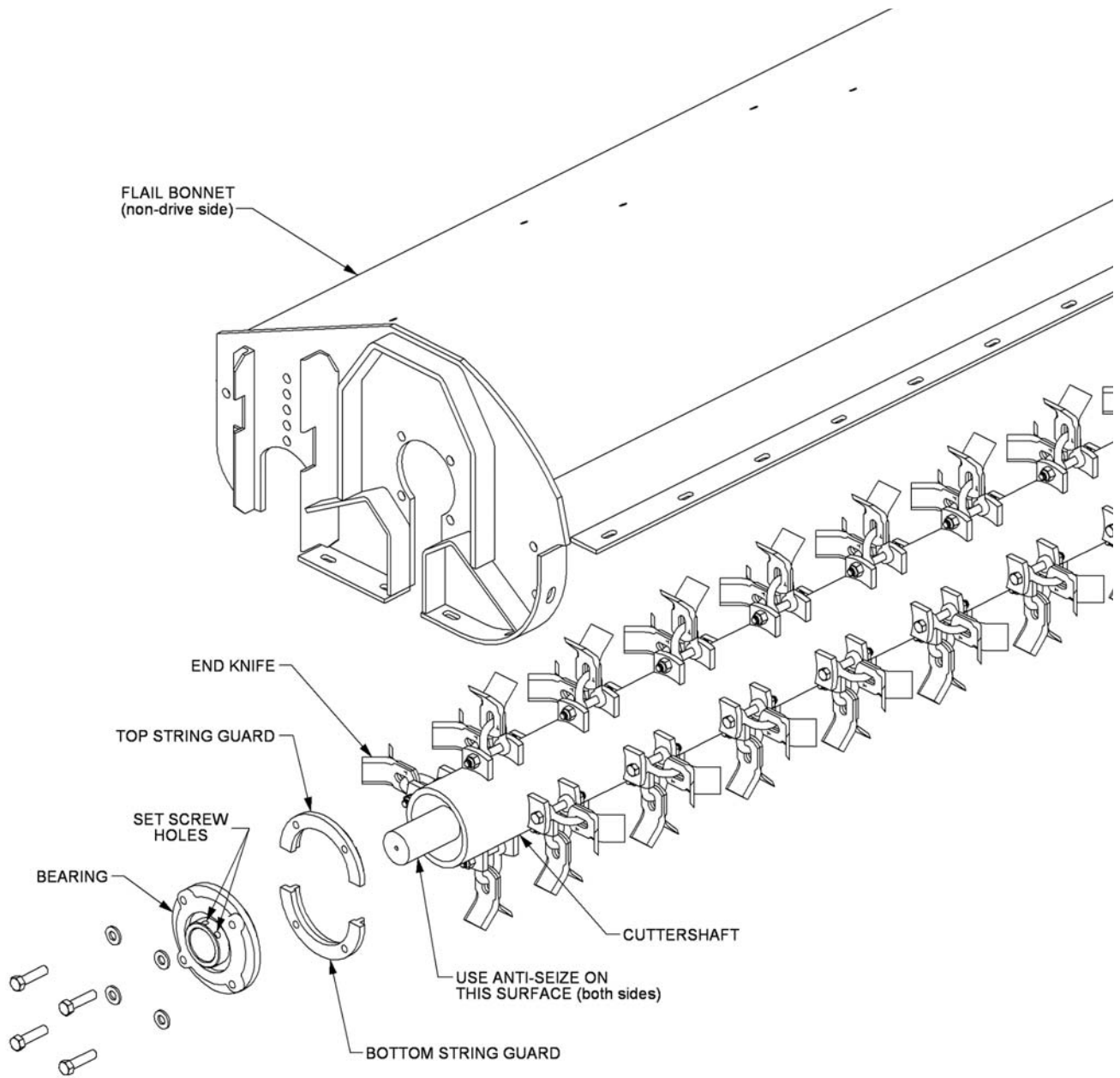

Boom

Maintenance Section 4-29

MAINTENANCE

MAINTENANCE

DAILY MAINTENANCE SCHEDULE

The following services should be performed daily or every 8 hours of service, following the detailed maintenance instructions in the operator's manual.

_____ Pump driveshaft: If required with drive shaft/coupler check for end play and lubricate at zerks.

_____ Crankshaft adapter: If equipped with rubber grommets check condition, replace if missing or damaged.

_____ Pivot points: Inject grease until it appears at ends.

_____ Hydraulic fittings: Check for leaks with paper or cardboard. Tighten fittings or replace hoses immediately.

_____ Knives: Inspect for missing or damaged knives, change (only complete sets) as needed.

_____ Belts: Check/tighten/replace belts as needed.

_____ Mainframe/deck: Unless otherwise specified retorque bolts according to torque specifications in this section.

_____ Hydraulic fluid level: Add, if required, per fluid recommendations.

_____ Rear flail drive, bearing flange and shaft couplers: Grease as instructed in the detailed maintenance section.

_____ Cuttershaft and ground roller: Grease as instructed in the detailed maintenance section.

Service performed by: _____ Date: ____/____/____ Hour

Meter: _____

Maintenance Section

**This page may be copied and used as part of the daily maintenance routine.

PARTS SECTION

PART NAME INDEX

RCTVUQTF GT&I 'I W&G	5
VTCEVQT'O QWP V'MK	6
VTCEVQT'O QWP V'MK/'J [FTCWN&E U	8
DQO 'O QWP V'MK	:
CZNG'DTCEG.'TGCT'UVQY	32
6"URQNE'CDNG'E QP VTQN'O QWP V	34
ECDNG*'O CP WCN+'N&H'XCNXG'/'6"URQNE	36
ECDNG*'O CP WCN+'N&H'XCNXG'/'6"URQNE.'EQP V&P WGF	38
7"URQNE'CDNG'E QP VTQN'O QWP V	3:
ECDNG*'O CP WCN+'N&H'XCNXG'/'7"URQNE	42
ECDNG*'O CP WCN+'N&H'XCNXG'/'7"URQNE.'EQP V&P WGF	44
LQ[UV&M'CP F 'UY &EJ DQZ 'O QWP V	46
CK'T&F'LQ[UV&M'CP F 'UY &EJ 'DQZ	48
LQ[UV&M'CP F 'UY &EJ DQZ '&V'O QWP V	4:
GNGEVTQP &E'RTQRQTVQPCN'N&H'XCNXG	52
VTCEVQT'TGO QVG'RQTVU*UVP F CTF	54
VTCEVQT'TGO QVG'RQTVU*RTGO KWO	55
ECDNG*'O CP WCN+'N&H'XCNXG'DTGCMF QY P '/'2872425:	56
ECDNG*'O CP WCN+'N&H'XCNXG'DTGCMF QY P '/'28724279	58
ECDNG*'O CP WCN+'N&H'XCNXG'DTGCMF QY P '/'287242; 5	5:
RWO R'F T&G UJ CHV'CUUGO DN[62
RQN[ECTDQP CVG'UCHGV['Y &F QY '*UVP F CTF	63
RQN[ECTDQP &G'UCHGV['Y &F QY '*RTGO KWO	64
P QVGU'3	65
RQN[ECTDQP CVG'UCHGV['Y &F QY '*RCP QTCO &E	66
UCHGV['UETGGP .'Y QE	68
HTQP V'72'I CNNQP 'VCP M'O QWP V	6:
Y J GGN'Y GK J V/'UVGGN'F KUJ	72
Y J GGN'Y GK J V/'ECUV'F KUJ	73
P QVGU'4	74

PARTS ORDERING GUIDE

The following instructions are offered to help eliminate needless delay and error in processing purchase orders for the equipment in this manual.

1. The Parts Section is prepared in logical sequence and grouping of parts that belong to the basic machine featured in this manual. Part Numbers and Descriptions are given to help locate the parts and quantities required.
2. The Purchase Order must indicate the **Name and Address** of the person or organization ordering the parts, **who should be charged**, and if possible, the **serial number of the machine** for which the parts are being ordered.
3. The purchase order must clearly list the **quantity of each part**, the complete and correct **part number**, and the basic **name of the part**.
4. The manufacturer reserves the right to substitute parts where applicable.
5. Some parts may be unlisted items which are special production items not normally stocked and are subject to special handling. Request a quotation for such parts before sending a purchase order.
6. The manufacturer reserves the right to change prices without prior notice.

NOTE: When ordering replacement decals, refer to the part numbers and descriptions listed in the safety section in the front of this manual.



For maximum safety and to guarantee optimum product reliability, always use genuine **Tiger** replacement parts. The use of inferior replacement parts may cause premature or catastrophic failure which could result in serious injury or death.

Direct any questions regarding parts to:

Tiger Corporation
3301 N. Louise Ave.
Sioux Falls, SD 57107
1-800-843-6849
1-605-336-7900

TRACTOR MOUNT KIT

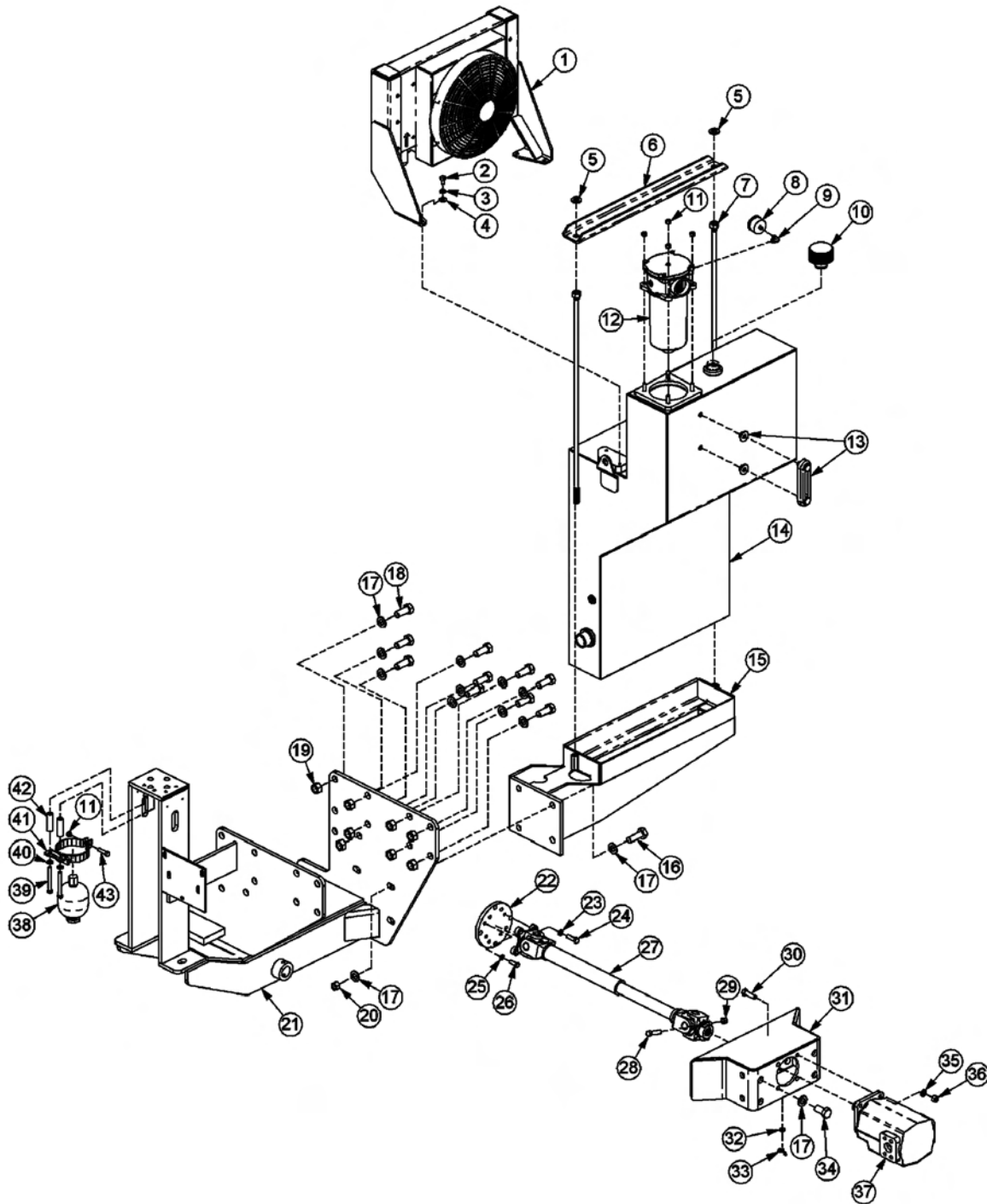

ITEM	PART NO.	QTY.	DESCRIPTION
3	/////	/	EQQNGT"CUUGO DN["QRVIQP
4	4384;	6	ECRUETGY .51 \$Z'5'6\$.PE
5	43; ::	6	NQEMY CUJ GT.51: \$
6	44238	6	HNCVY CUJ GT.51: \$

TRACTOR MOUNT KIT

Continued...

ITEM	PART NO.	QTY.	DESCRIPTION
7	55986	4	HNCVY CUJ GT.71 \$I T: .UCG
8	28632574	3	EJ CPPGN.OP V.VCP.MVKG/DQNV
9	285: 2236	4	VKG/DQNV.URFGVCP.MJ [FTQ
:	8V286;	3	HKNVGT'I CI G
;	VH6: ::	3	UVTGGV'GNDQY .31 \$
32	28727299	3	DTGCVJ GT'ECR
"/	289222; 2	/	TGUGTXQKT"VCP.MCUU 0
33	43849	7	P [NQEMP.WV.51 \$.PE
34	28727266	3	R/VCP.MHKNVGT'CUU
35	28727289	3	UK J V'I CI G
"/	28725358	3	UGCN'MK/UK J V'I CI G*PQV'UJ QY P+
36	285: 2234	3	J [FTCWNE'TGUGTXQKT"VCP.M
37	28522282	3	OP.V.J [FTQ"VCP.MLF8222
38	43: 55	6	ECRUETGY .516\$Z'4/316\$.PE
39	55: : 2	54	HNCVY CUJ GT.516\$.I T: .UCG
3:	53953	42	ECRUETGY .42O O'Z'72O O .40'RKWEJ
3:	53944	38	J GZ'P.W.42O O.I T320'.HNP I
42	43: 47	6	J GZ'P.W.516\$.PE
43	285222; 4	3	O CR'HTCO.G.IF9352
44	56; ; :	3	URCEGT.F.TK&GUJ CHV
45	43; ; :	6	NQEMY CUJ GT.9B8\$
46	438: 2	6	ECRUETGY .9B8\$Z'3/316\$.PE
47	548; 3	6	NQEMY CUJ GT.32O O
48	45335	6	ECRUETGY .32O O'Z'52O O .30'RKWEJ
49	56; ; :	3	FTK&GUJ CHV.WLQRP V
4:	4387:	3	ECRUETGY .9B8\$Z'4\$.PHI T:
4:	56: 6:	3	J GZ'P.W.9B8\$.PHI T:
52	43954	6	ECRUETGY .314\$Z'3/516\$.PE
53	56; ; 5	3	RWO.R'OP.V.IF.WFT&G
54	44236	3	HNCVY CUJ GT.316\$
55	5473;	3	P.W.Y R'I .316/42"WPE
56	46: 82	6	ECRUETGY .42O O'Z'62O O *40'RKWEJ +
57	43; ; 2	6	NQEMY CUJ GT.314\$
58	43947	6	J GZ'P.W.314\$.PE
59	45374	3	RWO.R.R572/3/516'I GCT
5:	46522	3	CEEWO.WNCVQT
5:	43862	4	51 \$Z'5/314\$.PE
62	43; ; :	4	NQEMY CUJ GT.51 \$
63	45: ; :	3	DTMV.CEEWO.WNCVQT
64	28642276	4	URCEGT.516\$QF'Z'35154\$F'Z'4/314\$
65	43854	3	ECRUETGY .51 \$Z'3/314\$.PE

JD7X30 BENGAL BRUTE

TRACTOR MOUNT KIT - HYDRAULICS

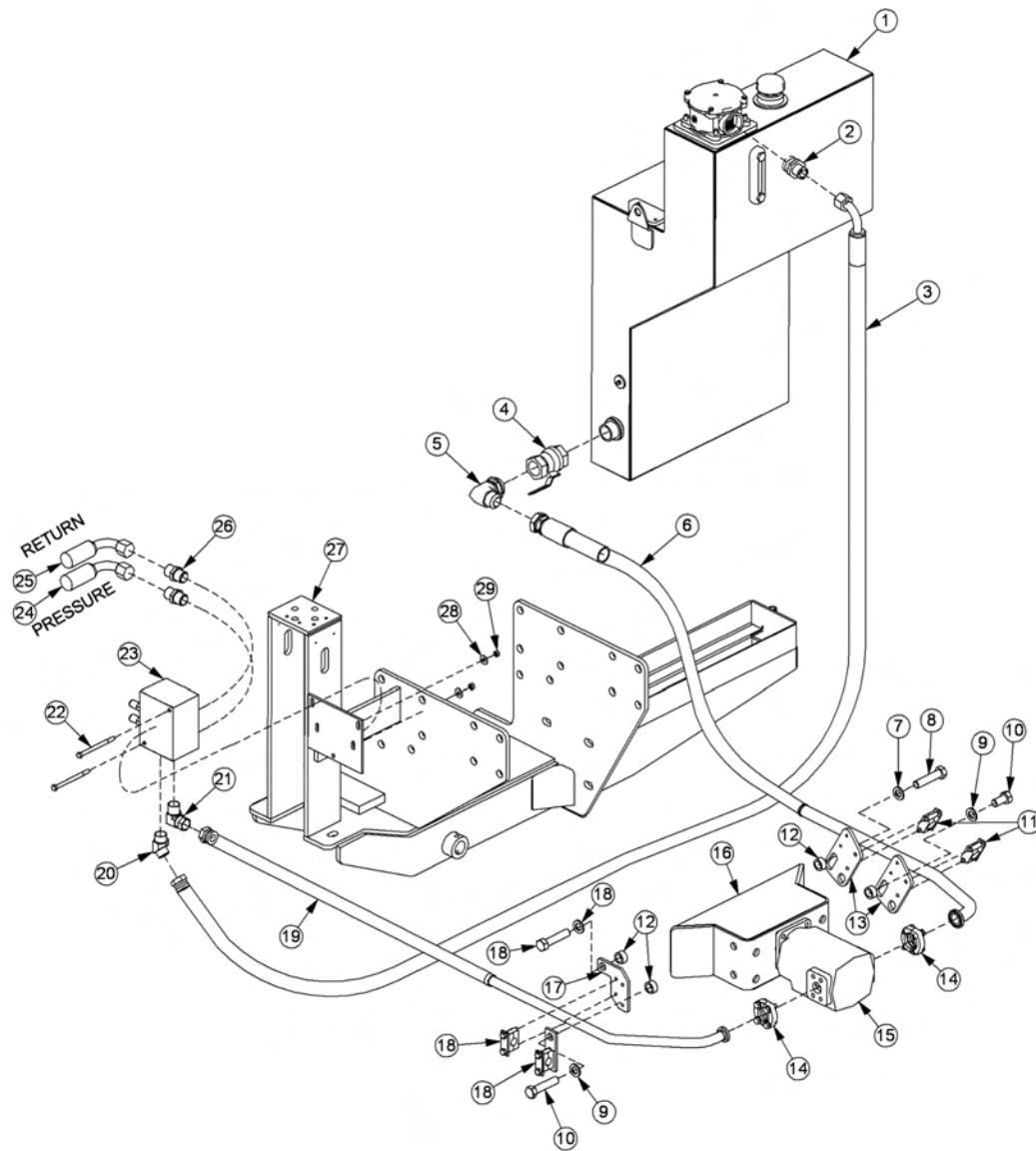

TRACTOR MOUNT KIT - HYDRAULICS

Continued...

ITEM	PART NO.	QTY.	DESCRIPTION
3	"/"////	3	VCPM', TGHGT"VQ"VTCEVQT"O QWP V'MK'RCI G
4	56286	3	CF CRVGT"3/3 16\$O QT"Z"3\$O L
5	28722292	3	J QUG.3\$Z"; 5\$
6	5652;	3	DCNN'XCNXG.3/3 4\$HQT
7	56877	3	GNDQY .3/3 4\$O QT"Z"3/3 4\$O L
8	28728258	3	J QUGIVWDG.3/3 4\$Z"9; \$
9	56: 55	3	HNCVY CUI GT.38O O
:	44645	3	ECRUETGY .38O O"Z"72O O.4ØR
;	55: : 2	4	HNCVY CUI GT.516\$.I T: .UCG
32	5292:	4	ECRUETGY .42O O"Z"; 2O O.4ØR
33	28727239	4	ENCOR'MK'.3\$J QUG.UR' I NG
34	46: 6;	6	URCEGT
35	286229: 8	4	DTMV.ENCOR.VWDG.UWEVQIP
36	VH6: 74	4	MK'.HNCPI G.%42
37	"/"////	3	RWOR", TGHGT"VQ"VTCEVQT"O QWP V'MK'RCI G
38	"/"////	3	RWO"O QWP V", TGHGT"VQ"VTCEVQT"O QWP V'MK'RCI G
39	56848	3	DTCEMGV.VWDGIENCOR
3:	56298	4	ENCOR'MK'.3\$
3;	28728259	3	J QUGIVWDG.3\$Z"; 2\$
42	55776	3	GNDQY .3\$O QT"Z"3\$O L67à
43	56339	3	GNDQY .3\$O QT"Z"3\$O L; 2à
44	43866	4	ECRUETGY .51: \$Z"7\$.PE
45	287322: 5	3	XCNXG.DTCMG.UQN.5222RUKO GVTK
46	2872254;	3	J QUG.RTGUWTG
47	2872254:	3	J QUG.TGVWTP
48	55777	4	CF CRVGT.3\$O QT"Z"3\$O L
49	"/"////	3	O C'R'HTCO G', TGHGT"VQ"VTCEVQT"O QWP V'MK'RCI G
4:	44238	4	HNCVY CUI GT.51: \$
4;	43847	4	J GZ" P WW.51: \$.PE

BOOM MOUNT KIT

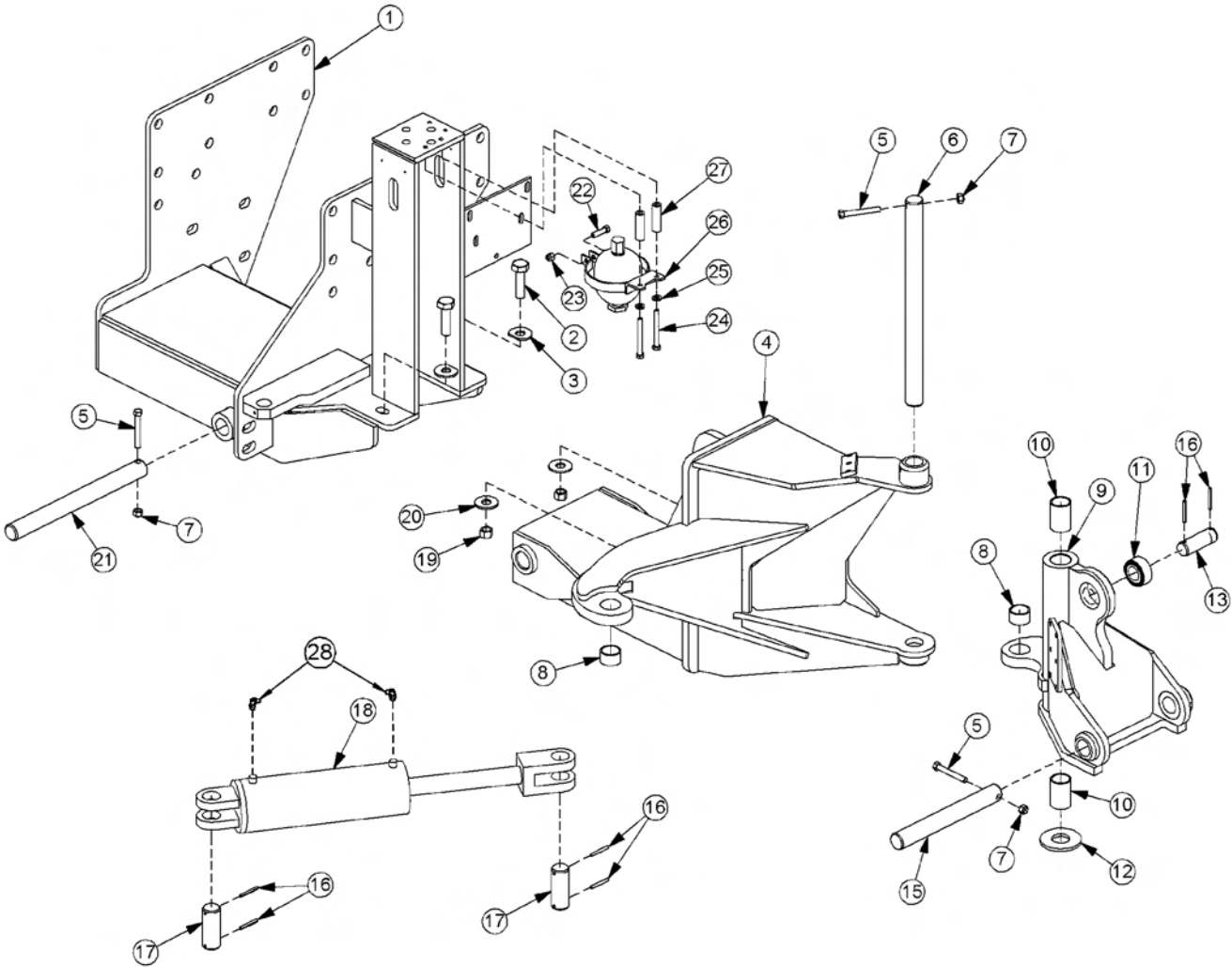

BOOM MOUNT KIT

Continued...

ITEM	PART NO.	QTY.	DESCRIPTION
3	/////	/	O CR 'HTCO G', TGHGT"VQ"VTCEVQT"O QWP VRCI G
4	43: 57	4	ECRUETGY .516\$Z"4/516\$.PE
5	8V4829	4	HNCVY CUI GT.516\$.EWW
6	2892225;	3	OP V'DTMV.DQOQO.TUCUJ
7	438: :	5	ECRUETGY .9B8\$Z"5/316\$.PE
8	28642235	3	RIP .3/314\$Z"3: /91: \$
9	43899	5	P[NQEMP WW.9B8\$.PE
:	2874232:	4	DGCTRI .3/314\$Z"3\$.EQOR
;	28922239	3	UY KGN.TGCT"UVQY .CUJ
32	28742633	4	DGCTRI .3/314\$Z"4/314\$
33	/////	/	URJ GTIECN'DGCTRI ", TGHGTGPE'QPNI
34	2874226;	3	DGCTRI .Y CUI GT.UY RI
35	28642322	3	RIP .3/316\$Z"6\$
37	28642244	3	RIP .3/314\$Z"34\$
38	VD3245	8	TQNNRIP .9154\$Z"4\$
39	28642245	4	RIP .3/314\$Z"5/71: \$
3:	2872323;	3	E[NIPFGT.6\$Z"; \$
3;	43: 47	4	J GZ"PW.516\$.PE
42	44243	4	HNCVY CUI GT.516\$
43	8V5223	3	RIP .RPT"FTHV"DO"3/314\$Z"37/516\$
44	43854	3	ECRUETGY .51: \$Z"3/314\$.PE
45	43849	3	P[NQEMP WW.51: \$.PE
46	43862	4	ECRUETGY .51: \$Z"5/314\$.PE
47	43: :	4	NQEMY CUI GT.51: \$
48	45: :	3	DTCEMGV.CEEWO WNCVQT
49	28642276	4	URCEGT
4:	54: 32	4	GNDQY

AXLE BRACE, REAR STOW

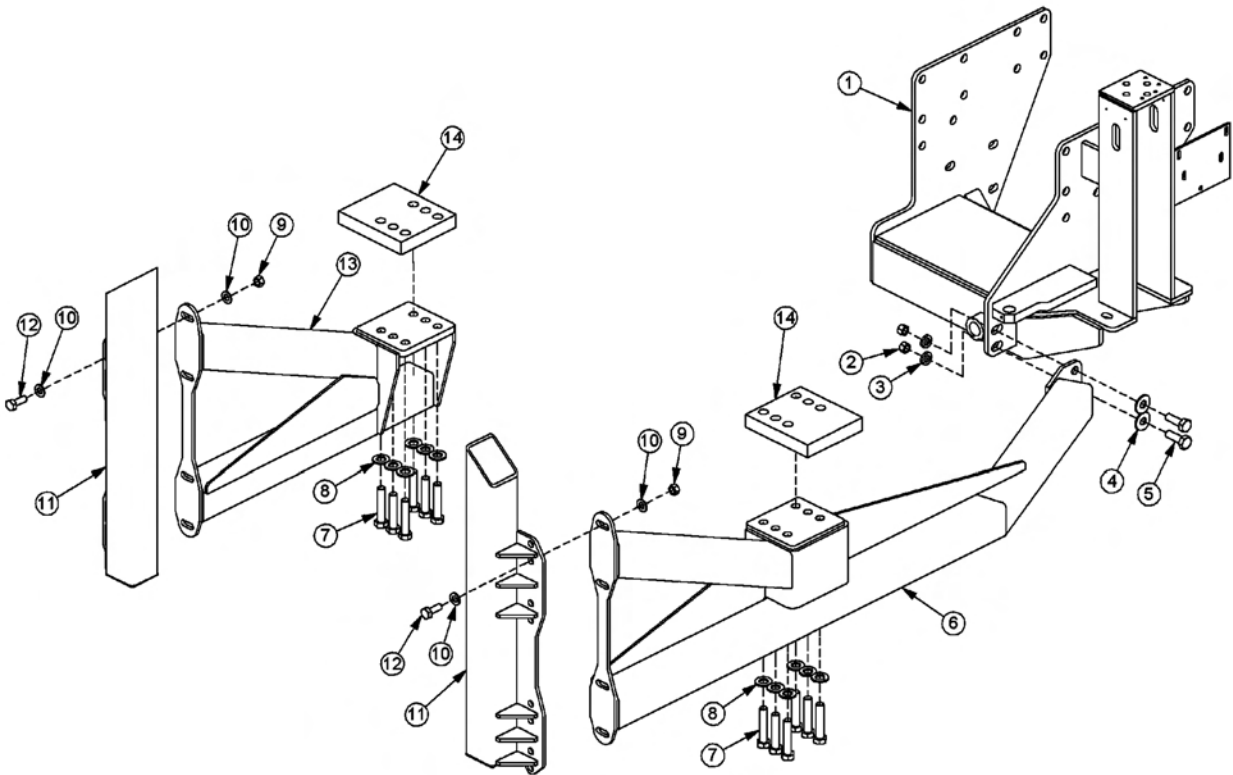

AXLE BRACE, REAR STOW

Continued...

ITEM	PART NO.	QTY.	DESCRIPTION
3	285222; 4	3	O CR 'HTCOG
4	43; 47	4	J GZ 'P WW.5 16\$.PE
5	43; ; 5	4	NQEMY CUJ GT.5 16\$.I T"
6	44243	4	HNCVY CUJ GT.5 16\$
7	43; 55	4	ECRUETGY .5 16\$Z "4/3 16\$.PE
8	285222; 5	3	CZNG'DTCEG.TJ
9	54925	34	ECRUETGY .42O O "Z "322O O "40"RWEJ +
:	28755222	34	HNCVY CUJ GT.9 16\$.UCG
;	43997	:	J GZ 'P WW.7 16\$.PE
32	43; ; 4	38	NQEMY CUJ GT.7 16\$.S
33	28532257	3	DQQO TGUV.DCUG.TU
34	439; 4	:	ECRUETGY .7 16\$Z "3/5 16\$.PE
35	285222; 6	3	CZNG'DTCEG.NJ
36	28622395	4	URCEGT.CZNG'DTCEG"LF9352"('9452"QP N +

4 SPOOL CABLE CONTROL MOUNT

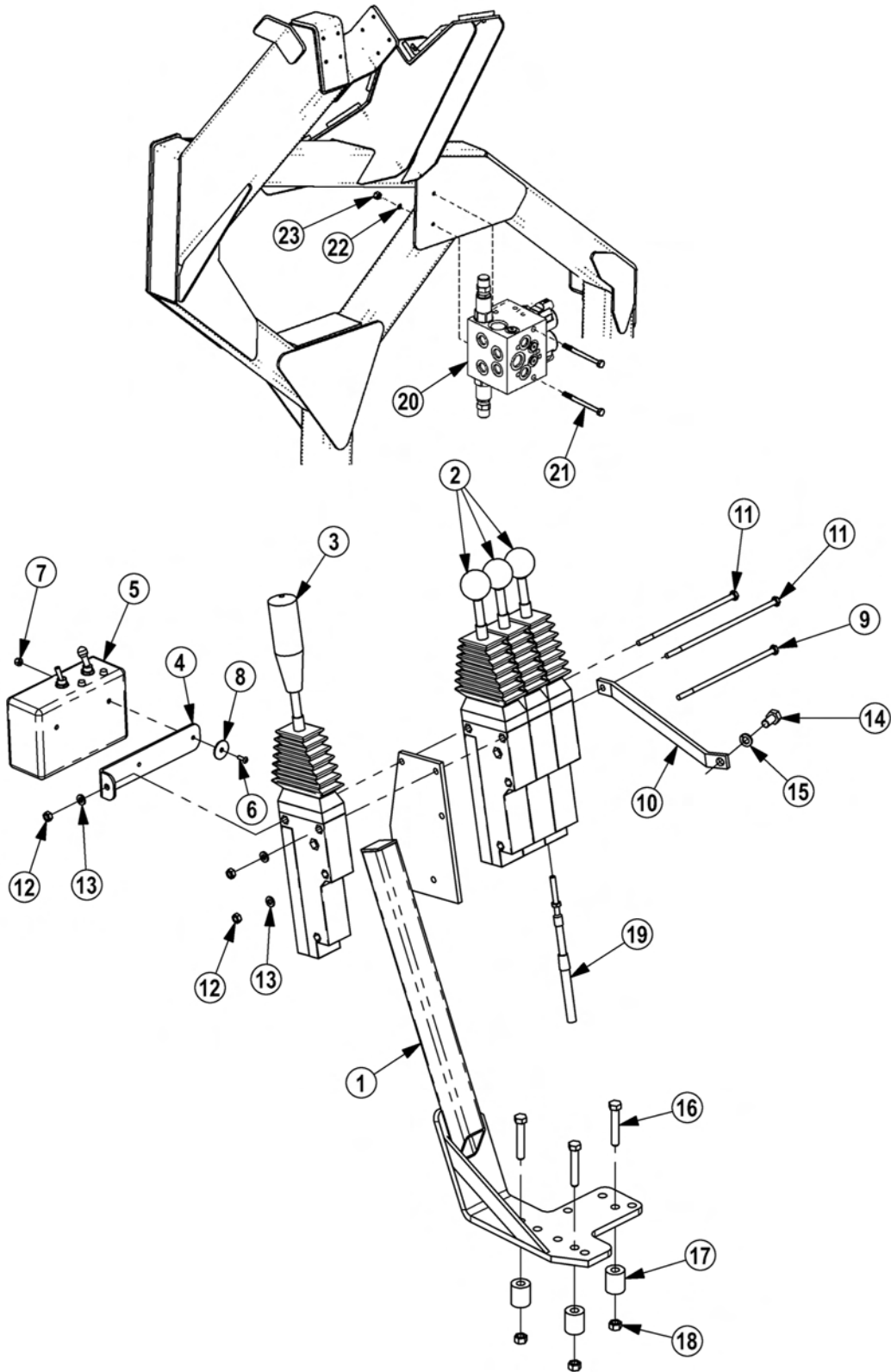

4 SPOOL CABLE CONTROL MOUNT

Continued...

ITEM	PART NO.	QTY.	DESCRIPTION
3	45: 87D	3	EDNEVTN'O V'DTM
4	8V3473	5	EDNEVTN'DQZ.3: 2'F GI
5	28727245	3	EDNEVTN'DQZ.3: 2'F GI .Y IDWVQP
6	566; 8	3	DTMV.UY KVEJ DQZ.WP K
7	2873226;	3	UY KVEJ DQZ 'CUUJ .DQOQO .TU
8	8V5; 73	4	UETGY .O CEJ KPG: 54\$Z'34\$
9	8V5; 74	4	J GZ 'P WW.: 54\$.P [NQEM
:	5672:	4	Y CUJ GT.HGP FGT.%2
;	43768	3	ECRUETGY .3 16\$Z'9\$.PE
32	52972C	3	DTMV.EDNEVTN
33	43769	4	ECRUETGY .3 16\$Z'\$. \$.PE
34	43747	5	J GZ 'P WW.3 16\$.PE
35	43; : 8	5	NQEMY CUJ GT.3 16\$
36	55756	3	ECRUETGY .320 O 'Z'420 O .307RWEJ
37	548; 3	3	NQEMY CUJ GT.320 O
38	43857	5	ECRUETGY .51 \$Z'4/3 16\$.PE
39	492: 4D	5	URCEGT
3:	43849	5	P [NQEMP WW.51 \$.PE
3;	56845	6	EDNEP VTN.344
42	28724277	3	XNX.UGNGEVQT.TU
43	437; 5	4	ECRUETGY .7B8\$Z'6/34\$.PE
44	43; : 9	4	NQEMY CUJ GT.7B8\$
45	43797	4	J GZ 'P WW.7B8\$.PE

CABLE (MANUAL) LIFT VALVE - 4 SPOOL

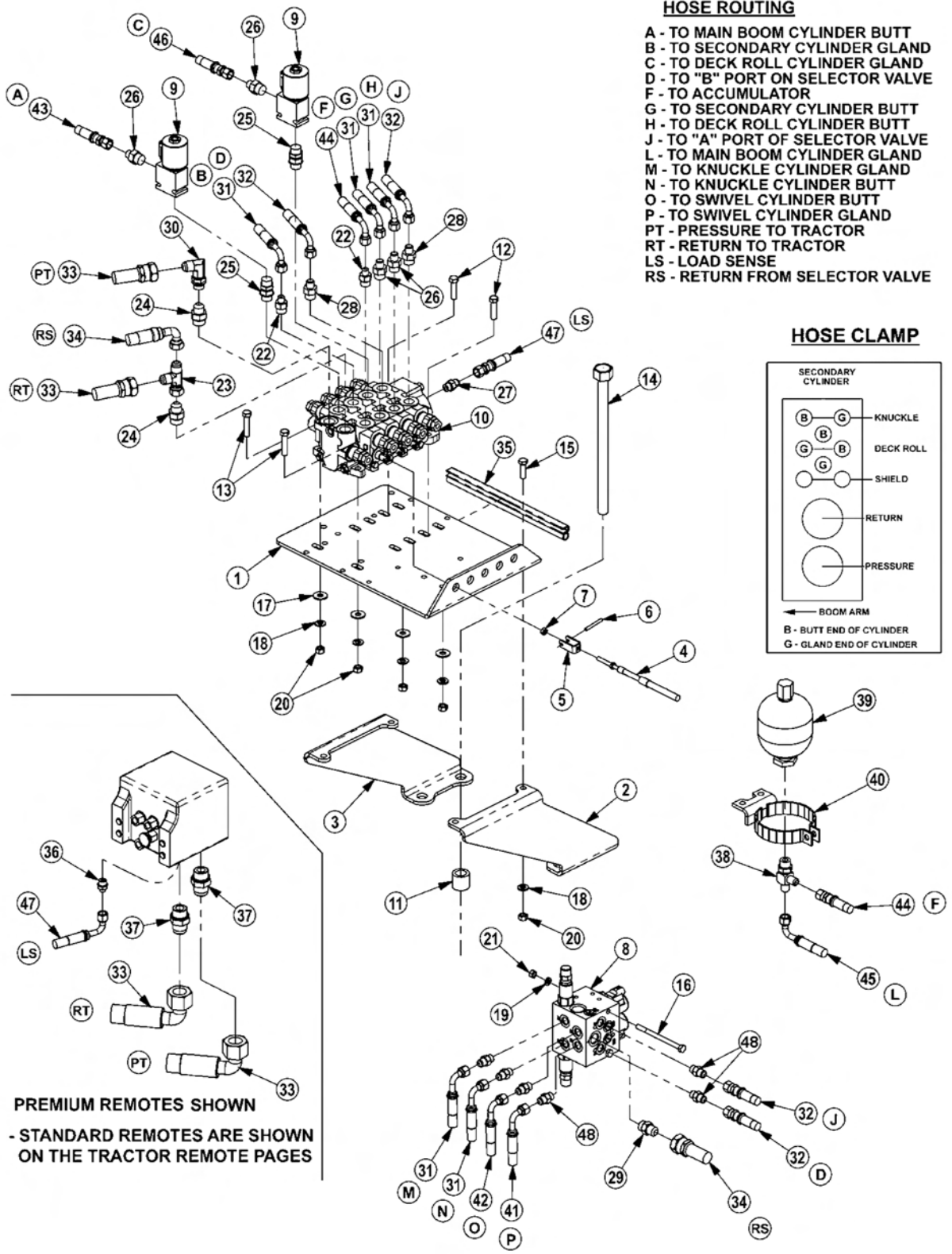

HOSE ROUTING

- A - TO MAIN BOOM CYLINDER BUTT
- B - TO SECONDARY CYLINDER GLAND
- C - TO DECK ROLL CYLINDER GLAND
- D - TO "B" PORT ON SELECTOR VALVE
- F - TO ACCUMULATOR
- G - TO SECONDARY CYLINDER BUTT
- H - TO DECK ROLL CYLINDER BUTT
- J - TO "A" PORT OF SELECTOR VALVE
- L - TO MAIN BOOM CYLINDER GLAND
- M - TO KNUCKLE CYLINDER GLAND
- N - TO KNUCKLE CYLINDER BUTT
- O - TO SWIVEL CYLINDER BUTT
- P - TO SWIVEL CYLINDER GLAND
- PT - PRESSURE TO TRACTOR
- RT - RETURN TO TRACTOR
- LS - LOAD SENSE
- RS - RETURN FROM SELECTOR VALVE

HOSE CLAMP

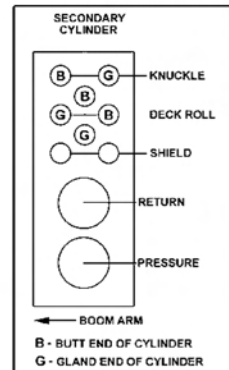

PREMIUM REMOTES SHOWN
 - STANDARD REMOTES ARE SHOWN ON THE TRACTOR REMOTE PAGES

CABLE (MANUAL) LIFT VALVE - 4 SPOOL

Continued...

ITEM	PART NO.	QTY.	DESCRIPTION
3	56844	3	RNCVG.XCNXG.TGCT"O P V
4	2863264;	3	O QWP V.XCNXG.TK J V
5	28632652	3	O QWP V.XCNXG.NGHV
6	56845	6	EDNEP.VTN.344\$
7	8V6633	6	ENGXKUEDN'EVTN.5B8\$
8	8V5239	6	TQNNRP .5B8\$Z'3\$
9	43722	6	J GZ'P WW.3 16\$.PH
:	28724277	3	XNX.UGNGEVQT.TU
;	28732272	4	VTX"NEMO GVT"RCEME"EQN
32	287242; 5	3	XNX.6URJ UE.VTD.NUTU*"TQVCT['O QY GTU+
///	28724279	3	XNX.6URJ UE.VDHNUTU*"HNCN'O QY GTU+
33	5673;	6	URCEGT.3/3 16\$Z'35B8\$Z'3/3 1\$
34	43854	4	ECRUETGY .5 1\$Z'3/3 14\$.PE
35	43855	4	ECRUETGY .5 1\$Z'3/5 16\$.PE
36	28752736	6	ECRUETGY .3: O O'Z'4; 2O O.40RI T32Q
37	43853	6	ECRUETGY .5 1\$Z'3/3 16\$.PE
38	437; 5	4	ECRUETGY .7B8\$Z'6/3 14\$.PE
39	44238	6	HNCVY CUI GT.5 1\$
3:	43; : :	:	NQEMY CUI GT.5 1\$
3;	43; : 9	4	NQEMY CUI GT.7B8\$
42	43847	:	J GZ'P WW.5 1\$.PE
43	43797	4	J GZ'P WW.7B8.PE
44	28724258	4	XNX.EJ GEMY 128\$QTH
45	8V5; ; 4	3	TWP "VGG.3 14\$O LZ'3 14\$HZ'Z'3 14\$O L
46	28725233	4	CF CRVGT.7 1\$O QT'Z'3 14\$O L
47	5354;	4	CF CRVGT.3 14\$O QT'Z'3 14\$O QT.CFL
48	55493	6	CF CRVGT.3 14\$O QT'Z'5 1\$O L
49	54; 23	3	CF CRVGT.5 1\$O QT'Z'5 1\$O L*"UVCP FCTF "VTCEVQT+
///	28725364	3	CF CRVGT.EJ GEM"XCXG*"RTGO KWO "VTCEVQT+
4:	565; 8	4	CFRCVGT.TUVTEVT.3 14\$O QT'Z'5 1\$O L
4;	5574:	3	CF CRVGT.3 14\$O QT'Z'3 14\$O L
52	28725244	3	GNDQY .3 14\$HZ'Z'3 14\$O L; 2a
53	2872236:	7	J QUG.3 16\$Z'432\$
54	55633	4	J QUG.3 16\$Z'46\$
55	/////	/	J QUG', TGHGT"VQ"VTCEVQT"TGQ QVGURCI G
56	556: :	3	J QUG.3 14\$Z'47\$
57	4: 275	3	VTO "NM; B8'Z'3 1\$ HP "RDN, 322/3 1\$
58	/////	/	CF CRVGT", TGHGT"VQ"VTCEVQT"TGQ QVGURCI G
59	/////	/	CFRVGT", TGHGT"VQ"VTCEVQT"TGQ QVGURCI G
5:	2872524;	3	VGG.TWP .3 14\$O QT'Z'5 1\$O LZ'5 1\$O L
5;	46522	3	CEEWO WNCVGT

JD7X30 BENGAL BRUTE

CABLE (MANUAL) LIFT VALVE - 4 SPOOL, CONTINUED

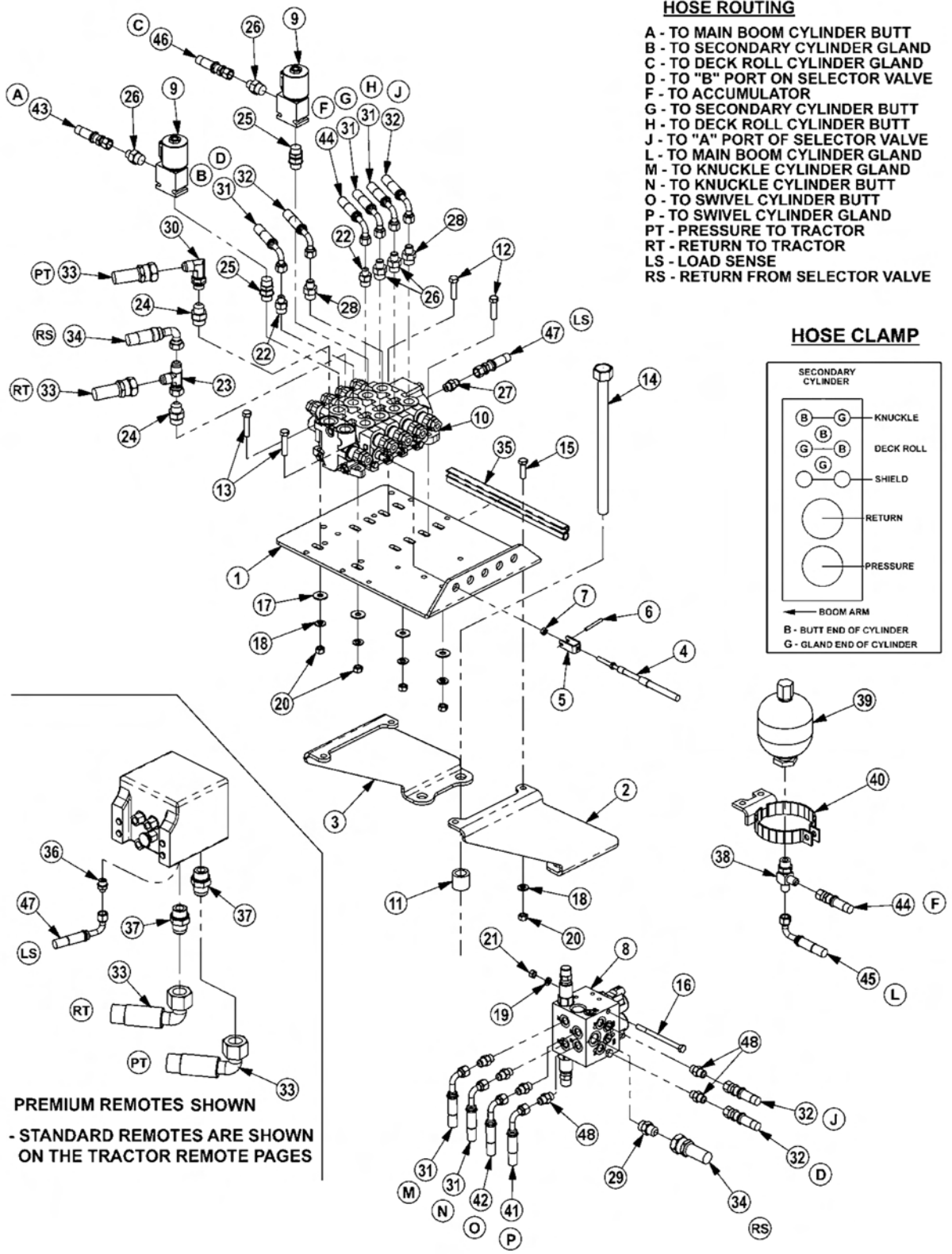

CABLE (MANUAL) LIFT VALVE - 4 SPOOL, CONTINUED

Continued...

ITEM	PART NO.	QTY.	DESCRIPTION
62	45: : :	3	DTMV.CEEWO WNCVQT
63	56853	3	J QUG.3 16\$Z"348\$
64	5657;	3	J QUG.3 16\$Z"332\$
65	2872236;	3	J QUG.3 16\$Z"442\$
66	28722372	3	J QUG.3 16\$Z"364\$
67	28722373	3	J QUG.3 16\$Z"334\$
68	28722397	3	J QUG.3 16\$Z"432\$
69	//////	/	J QUG', TGHGT"VQ"VTCEVQT" TGO QVGURCI G
6:	54; 23	8	CF CRVGT.5E \$O QT"Z"5E \$OL
///	28727257	3	XCNXGEQXGT"/"P QP" ECD'QP N[" *P QV"UJ QY P+

5 SPOOL CABLE CONTROL MOUNT

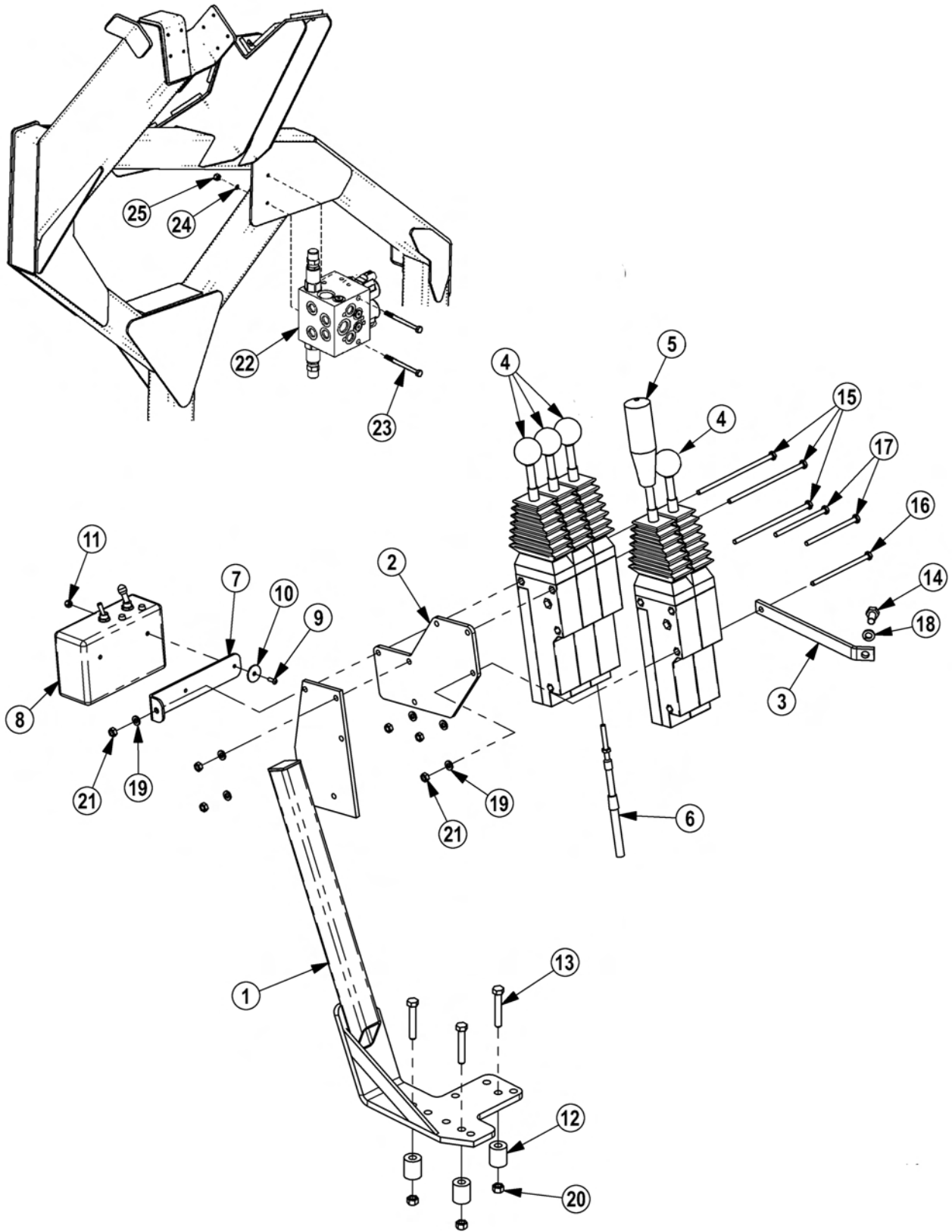

5 SPOOL CABLE CONTROL MOUNT

Continued...

ITEM	PART NO.	QTY.	DESCRIPTION
3	45: 87D	3	EDNEVTN'O V'DTM
4	2862239;	3	O P V.CF RVT.EP VTN'DQZ.4" TQY
5	2863245;	3	UWRRQTV.O P V.EP VTN'DQZ.4" TQY
6	8V3473	6	EDNEVTN'DQZ.3: 2' FGI
7	28727245	3	EDNEVTN'DQZ.3: 2' FGI .Y IDWVQP
8	56845	7	EDNEPVTN.344
9	566; 8	3	DTMV.UY KVEJ DQZ.WP K
:	2873226;	3	UY KVEJ DQZ 'CUUJ .DQOQO .TU
;	8V5; 73	4	UETGY .OCEJ R G: 154\$Z'34\$
32	5672:	4	Y CUJ GT.HGP FGT.%2
33	8V5; 74	4	J GZ'P WW.: 154\$.P [NQEM
34	492: 4D	5	URCEGT
35	43857	5	ECRUETGY .51 \$Z'4/316\$.PE
36	55756	3	ECRUETGY .32O O'Z'42O O .30RWEJ
37	43767	5	ECRUETGY .316\$Z'8\$.PE
38	43765	3	ECRUETGY .316\$Z'6/34\$.PE
39	43764	4	ECRUETGY .316\$Z'6\$.PE
3:	548; 3	3	NQEMY CUJ GT.32O O
3;	43; : 8	8	NQEMY CUJ GT.316\$
42	43849	5	P [NQEMP WW.51 \$.PE
43	43747	8	J GZ'P WW.316\$.PE
44	28724277	3	XNX.UGNGEVQT.TU
45	437; 5	4	ECRUETGY .7B8\$Z'6/34\$.PE
46	43; : 9	4	NQEMY CUJ GT.7B8\$
47	43797	4	J GZ'P WW.7B8\$.PE

CABLE (MANUAL) LIFT VALVE - 5 SPOOL

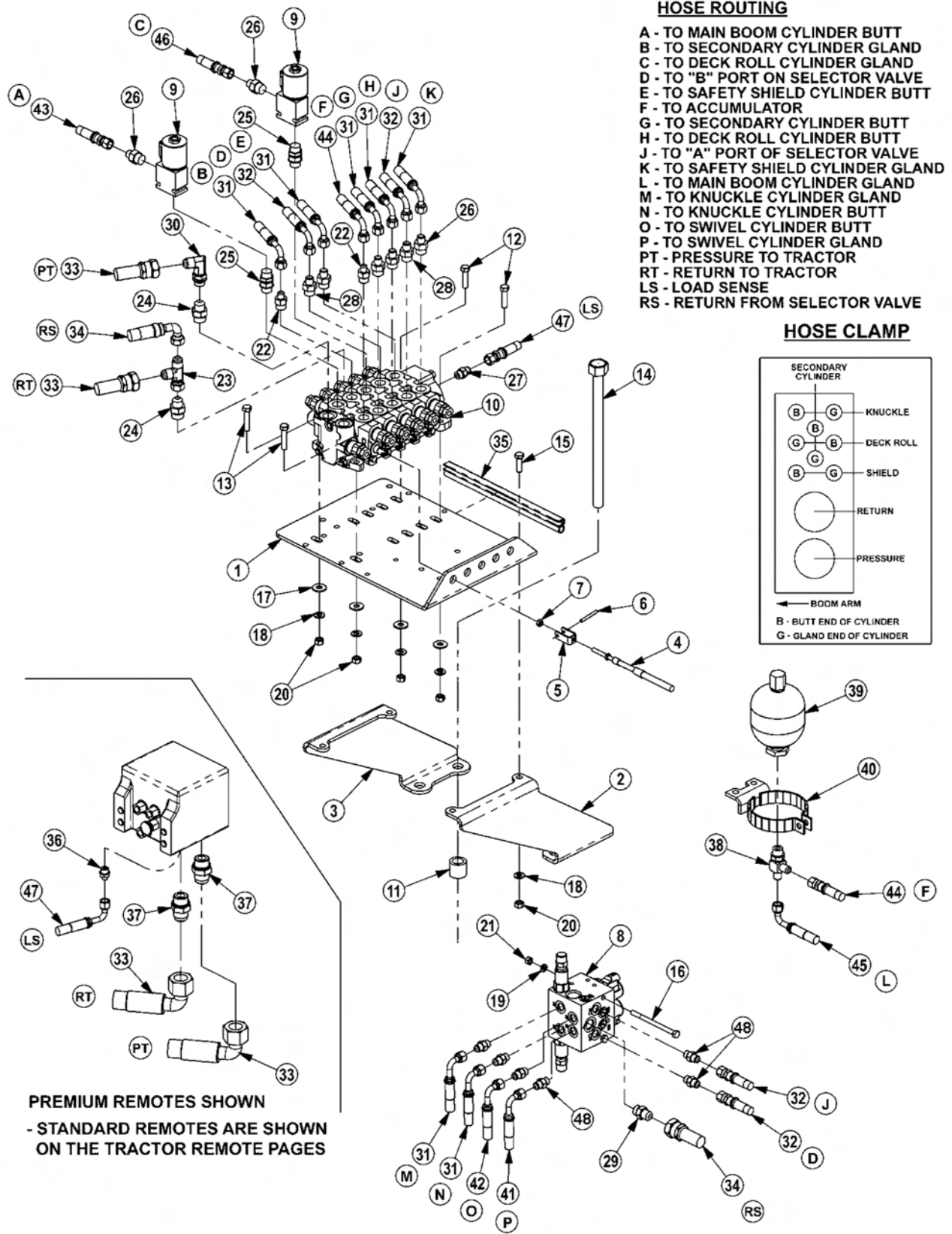

CABLE (MANUAL) LIFT VALVE - 5 SPOOL

Continued...

ITEM	PART NO.	QTY.	DESCRIPTION
3	56844	3	RNCVG.XCNXG.TGCT"O P V
4	2863264;	3	O QWP V.XCNXG.TK J V
5	28632652	3	O QWP V.XCNXG.NGHV
6	56845	7	EDNEP VTN.344\$
7	8V6633	7	ENGXKUEDN'EVTN.5 B8\$
8	8V5239	7	TQNNRRP .5 B8\$Z '3\$
9	43722	7	J GZ 'P WW.3 16\$.PH
:	28724277	3	XNX.UGNGEVQT.TU
;	28732272	4	VTX"NEMO GVT RRCEMEQKN
32	2872425:	3	XNX.7URI UE.VTD.NUTU* TQVCT['O QY GTU+
33	5673;	6	URCEGT.3/3 16\$Z '35 B8\$Z '3/3 1\$
34	43854	4	ECRUETGY .5 1\$Z '3/3 14\$.PE
35	43855	4	ECRUETGY .5 1\$Z '3/5 16\$.PE
36	28752736	6	ECRUETGY .3: O O 'Z '4; 2O O .40R.I T32Q
37	43853	6	ECRUETGY .5 1\$Z '3/3 16\$.PE
38	437; 5	4	ECRUETGY .7 B8\$Z '6/3 14\$.PE
39	44238	6	HNCVY CUJ GT.5 1\$
3:	43; : :	:	NQEMY CUJ GT.5 1\$
3;	43; : 9	4	NQEMY CUJ GT.7 B8\$
42	43847	:	J GZ 'P WW.5 1\$.PE
43	43797	4	J GZ 'P WW.7 B8.PE
44	28724258	4	XNX.EJ GEMY 128\$QTH
45	8V5; ; 4	3	TWP "VGG.3 14\$O LZ '3 14\$HLZ 'Z '3 14\$OL
46	28725233	4	CF CRVGT.7 1\$O QT'Z '3 14\$OL
47	5354;	4	CF CRVGT.3 14\$O QT'Z '3 14\$O QT.CFL
48	55493	8	CF CRVGT.3 14\$O QT'Z '5 1\$OL
49	54; 23	3	CF CRVGT.5 1\$O QT'Z '5 1\$OL*UVCP FCTF 'VTCEVQT+
///	28725364	3	CF CRVGT.EJ GEM'XCNXG*RTGO KWO 'VTCEVQT+
4:	565; 8	4	CF CRVGT.TUVTEVT.3 14\$O QT'Z '5 1\$OL
4;	5574:	3	CF CRVGT.3 14\$O QT'Z '3 14\$OL
52	28725244	3	GNDQY .3 14\$HLZ 'Z '3 14\$O L; 2
53	2872236:	9	J QUG.3 16\$Z '432\$
54	55633	4	J QUG.3 16\$Z '46\$
55	/////	/	J QUG', TGHGT"VQ"VTCEVQT"TGQ QVGURCI G
56	556: :	3	J QUG.3 14\$Z '47\$
57	4: 275	3	VTO 'NM; B8'Z '3 1\$ HP 'RDN, 322/3 1\$
58	/////	/	CF CRVGT", TGHGT"VQ"VTCEVQT"TGQ QVGURCI G
59	/////	/	CF RVGT", TGHGT"VQ"VTCEVQT"TGQ QVGURCI G
5:	2872524;	3	VGG.TWP .3 14\$O QT'Z '5 1\$O LZ '5 1\$OL
5;	46522	3	CEEWO WNCVGT

JD7X30 BENGAL BRUTE

CABLE (MANUAL) LIFT VALVE - 5 SPOOL, CONTINUED

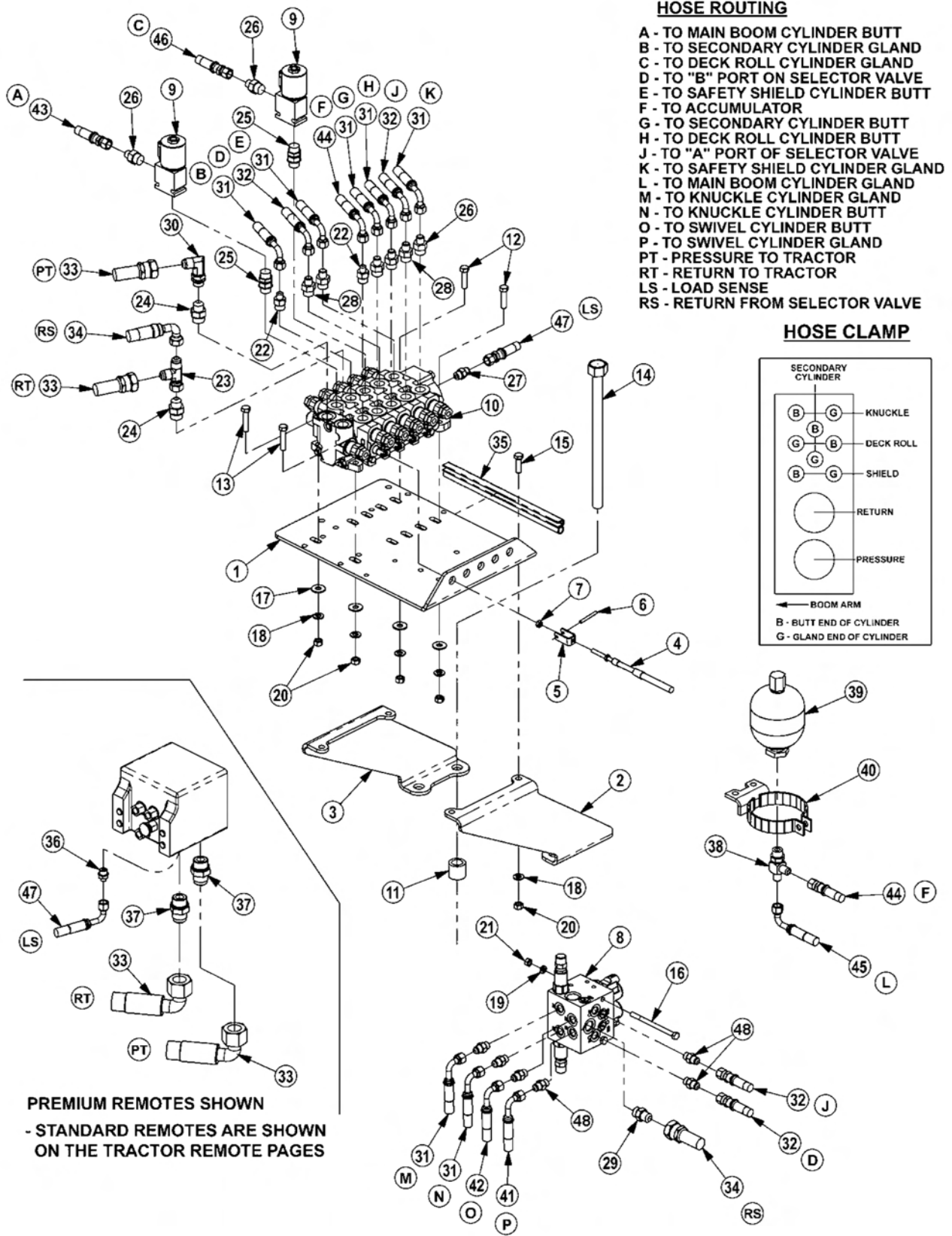

CABLE (MANUAL) LIFT VALVE - 5 SPOOL, CONTINUED

Continued...

ITEM	PART NO.	QTY.	DESCRIPTION
62	45: : :	3	DTMV.CEEWO WNCVQT
63	56853	3	J QUG.3 16\$Z"348\$
64	5657;	3	J QUG.3 16\$Z"332\$
65	2872236;	3	J QUG.3 16\$Z"442\$
66	28722372	3	J QUG.3 16\$Z"364\$
67	28722373	3	J QUG.3 16\$Z"334\$
68	28722397	3	J QUG.3 16\$Z"432\$
69	/////	/	J QUG', TGHGT"VQ"VTCEVQT"TGQ QVGURCI G
6:	54; 23	8	CF CRVGT.51 \$O QT"Z"51 \$OL
///	28727257	3	XCNXGEQXGT"/"P QP"ECD'QPN["P QV"UJ QY P+

JOYSTICK AND SWITCHBOX MOUNT

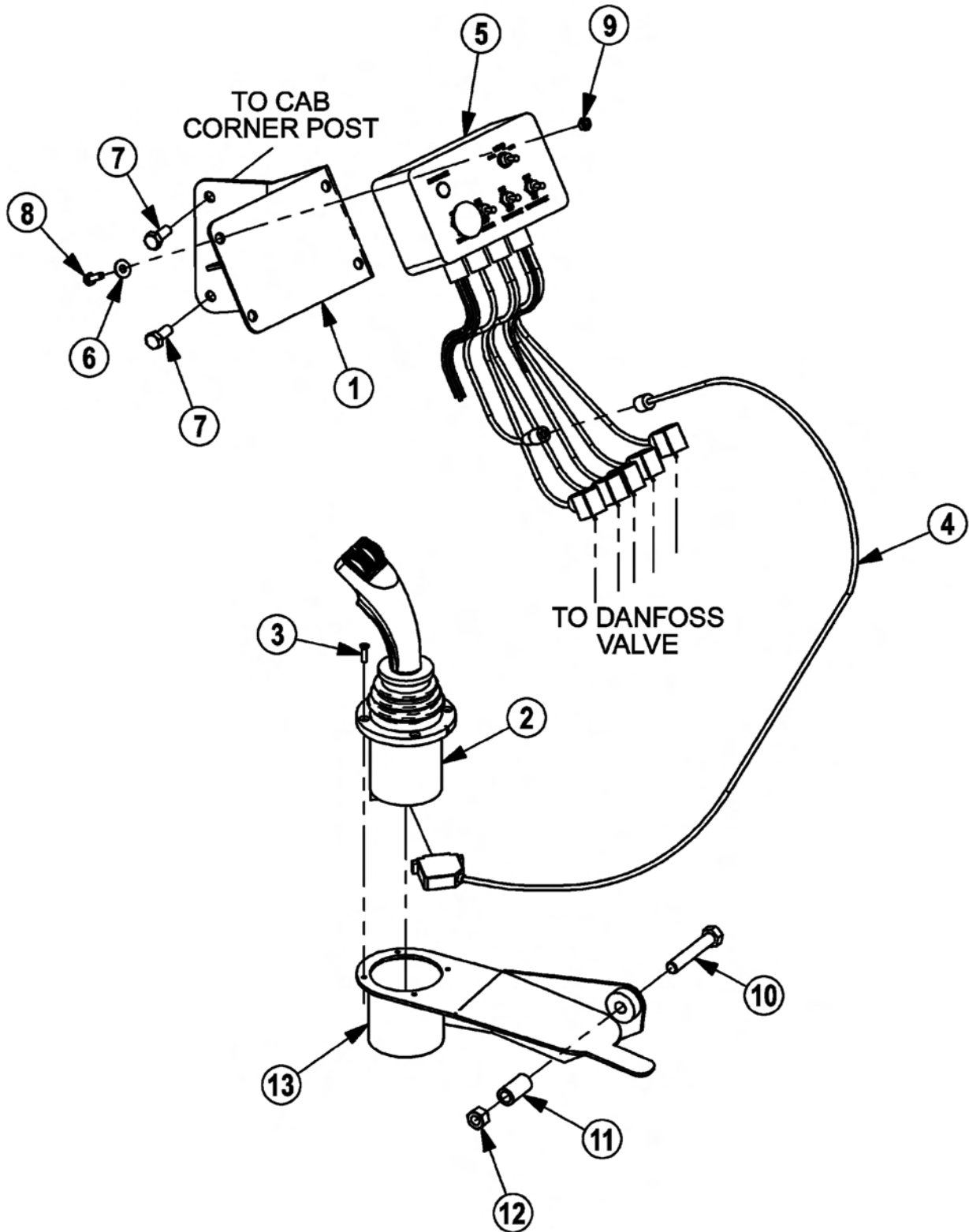

JOYSTICK AND SWITCHBOX MOUNT

Continued...

ITEM	PART NO.	QTY.	DESCRIPTION
3	55577	3	OP V.DTMV.UY K/EJ 'DQZ
4	28732268	3	LQ[UV.6CZKUTJ .FHY IUSD/F'EQP P
5	54; 4;	6	UETGY .OCEJ P G.32/54Z516.HNCVJ F
6	558; 5	3	EDN.GZV.6HV.LQ[UV.Y IUSD/F'EQP P
7	287323; 7	3	UY K/EJ DQZ
8	44236	6	HNCVY CUI GT.316
9	49735	4	ECRUETGY .32O OZ47O O *30'RK/EJ +
:	4374;	6	ECRUETGY .316'Z'516'PE
;	43749	6	P[NQEMP WW.316'PE
32	43959	3	ECRUETGY .34'Z'5'PE
33	5557;	3	VWDG.URCEGT.LF 8222'LUVEM
34	43949	3	P[NQEMP WW.34'PE
35	55578	3	CTOTGUV.LQ[UVEM

AIR RIDE JOYSTICK AND SWITCH BOX

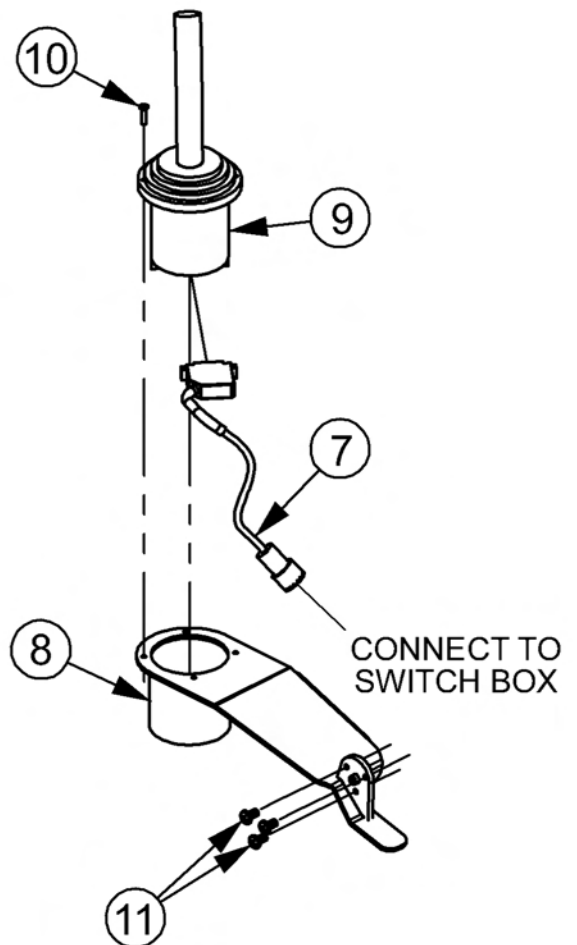
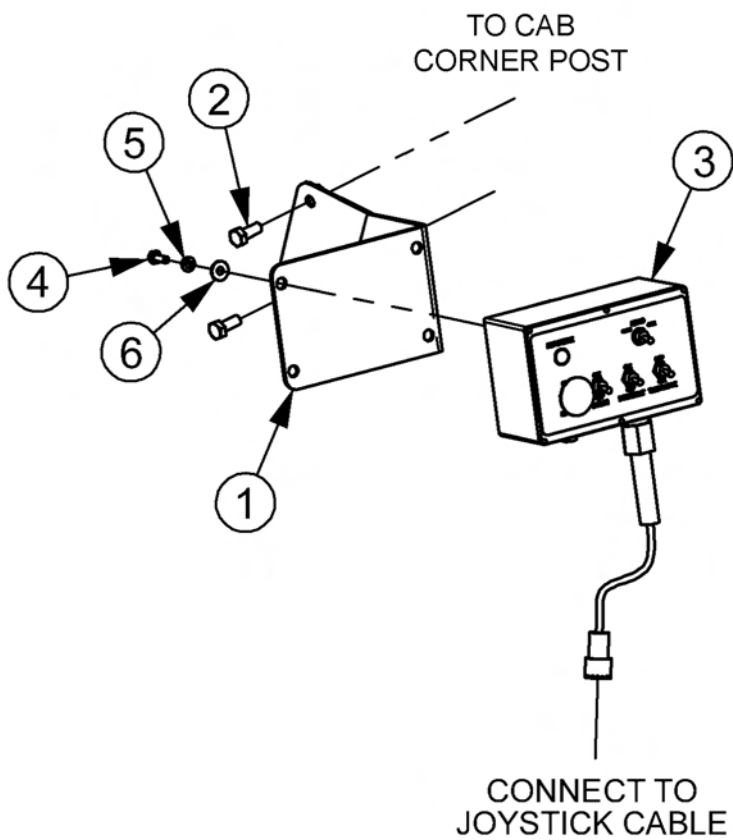

AIR RIDE JOYSTICK AND SWITCH BOX

Continued...

ITEM	PART NO.	QTY.	DESCRIPTION
3	55577	3	OP V.DTMV.UY KVEJ "DQZ
4	49735	4	ECRUETGY .320 O "Z"470 O .3ØR
5	287323; 7	3	UY KVEJ "DQZ.DQOQ
6	4374;	6	ECRUETGY .316\$Z"516\$.PE
7	43; : 8	6	NQEMY CUJ GT.316\$
8	44236	6	HNCVY CUJ GT.316\$
9	558; 5	3	EDN.GZ V.LQ[UVÆM
:	285922; 7	3	OP V.LQ[UVÆM
;	28732268	3	LQ[UVÆM
32	54; 4;	6	UETGY .OCEJ R G.32/54"Z"516\$.HNVI F
33	54625	5	UETGY .OCEJ R G.316/42"Z"314\$.RCP

JOYSTICK AND SWITCHBOX IVT MOUNT

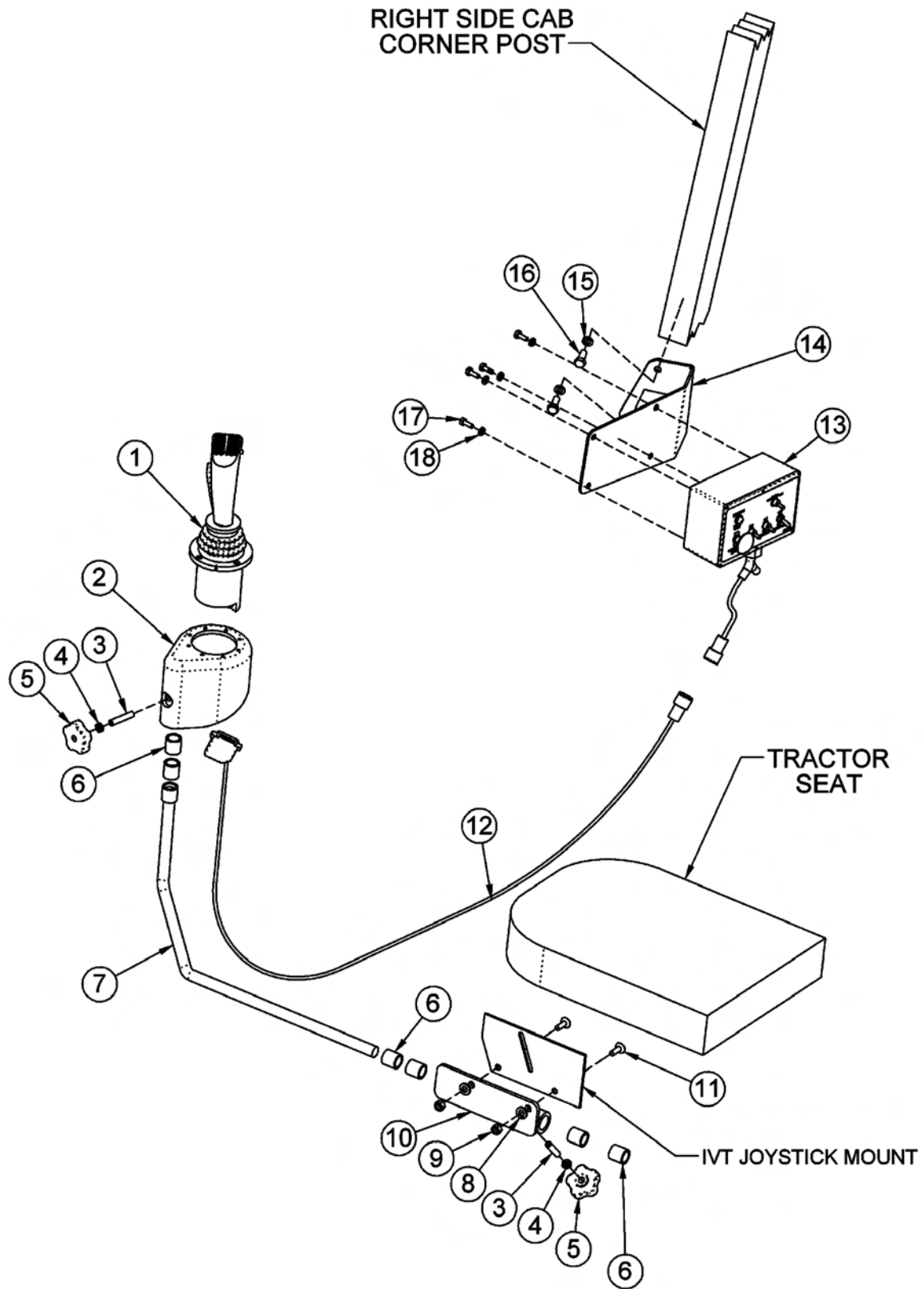

JOYSTICK AND SWITCHBOX IVT MOUNT

Continued...

ITEM	PART NO.	QTY.	DESCRIPTION
3	28732268	3	IQ[UVÆM
4	57255	3	ECP.IQ[UVÆM
5	57427	4	UGVUETGY .5I "Z"4.PE.MP WTNGF
6	57428	4	J GZ"P WW.ICOD.5I .PE
7	57426	4	MP QD
8	57478	9	DWUJ RPI .P[NQP
9	286422; 7	3	TQF .HQTO GF
:	43; : :	4	NQEMY CUJ GT.5I
;	43847	4	J GZ"P WW.5I .PE
32	285922; 5	3	OP V.IQ[UVÆMIF/K&V
33	4; 956	4	ECRUETGY .HNVUUV"J F.5I "Z"3.PE
34	558; 5	3	EDN.GZ V.6HV.IQ[UV.Y IUWD/F"EQP P
35	287323; 8	3	UY K&EJ DQZ
36	285922; 7	3	OP V.UY K&EJ DQZ
37	548; 3	4	NQEMY CUJ GT.32O O
38	473; :	4	ECRUETGY .32O O"Z"37O O *3ØR+
39	4374;	6	ECRUETGY .3I6"Z"5I6.PE
3:	43; : 8	6	NQEMY CUJ GT.3I6

ELECTRONIC PROPORTIONAL LIFT VALVE

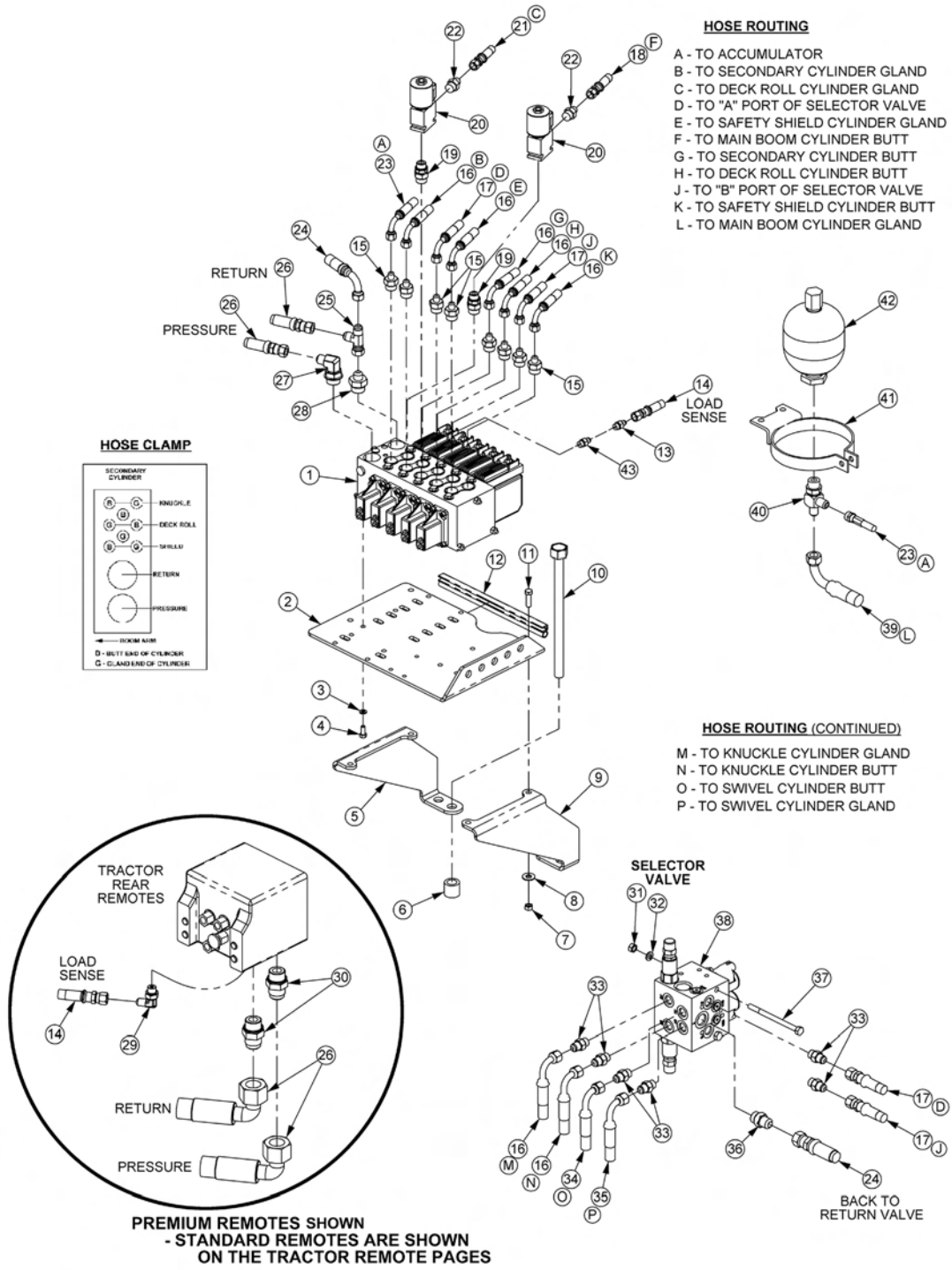

ITEM	PART NO.	QTY.	DESCRIPTION
3	287242; 9	3	GNGE VT QP KE 'N8HV'XCXNG//7'URQQN
4	56844	3	XCXNG'O QWP V8P I 'RNCVG
5	43; : 9	6	NQEMY CUI GT.7 B8\$
6	4379;	6	ECRUETGY .7 B8\$'Z "5 K\$.P.E

ELECTRONIC PROPORTIONAL LIFT VALVE

Continued...

ITEM	PART NO.	QTY.	DESCRIPTION
7	28632652	3	O QWP V.XCNXG.NGHV
8	5673;	6	URCEGT
9	43847	6	J GZ'P WW.51: 6.PE
:	43; ::	6	NQEMY CUJ GT.51: 6
;	2863264;	3	O QWP V.XCNXG.TK J V
32	28752736	6	ECRUETGY .3: O O 'Z'4; 2O O .40R
33	43853	6	ECRUETGY .51: 8'Z'3/3166.PE
34	4: 275	3	VTIO 'NQEM; B8\$
35	555; 4	3	CF CRVGT'*UVC P F CTF "VTCEVQT+
///	28725364	3	CF CRVGT.EJ GEM'XCXNG*'RTGO KWO "VTCEVQT+
36	/////	/	J QUG', TGHGT"VQ"VTCEVQT"TGQ QVGURCI G
37	54: 29	;	CF CRVGT
38	2872236:	9	J QUG.316\$Z'432\$
39	55633	4	J QUG.316\$Z'46\$
3:	2872236;	3	J QUG.316\$Z'4426
3;	53833	4	CF CRVGT.71: QT'Z'34"CF LQT
42	28732272	4	VTXGN'NQEM
43	28722397	3	J QUG.3166\$Z'4326
44	55493	4	CF CRVGT.34O QT'Z'51: O L
45	556; 4	3	J QUG.316\$Z'35: \$
46	556: :	3	J QUG.3146\$Z'476
47	8V5; ; 4	3	VGG.34O L'Z'34O L'Z'34HLZ
48	/////	/	J QUG', TGHGT"VQ"VTCEVQT"TGQ QVGURCI G
49	554; 6	4	GNDQY
4:	557; 3	3	CF CRVGT.516O QT'Z'34O L
4;	/////	/	CF CRVGT", TGHGT"VQ"VTCEVQT"TGQ QVGURCI G
52	/////	/	CF CRVGT", TGHGT"VQ"VTCEVQT"TGQ QVGURCI G
53	43797	4	J GZ'P WW.7B8\$.PE
54	43; : 9	4	NQEMY CUJ GT.7B8\$
55	54; 23	8	CF CRVGT.51: O QT'Z'51: O L
56	5657;	3	J QUG.3166\$Z'3326
57	56853	4	J QUG.3166\$Z'3486
58	5574:	3	CF CRVGT.34O QTD'Z'34O LK
59	437; 5	4	ECRUETGY .7B8\$Z'6/34\$.PE
5:	28724277	3	UGNGEVQT"XCXNG
5;	28722373	3	J QUG.316\$Z'334\$
62	2872524;	3	TWP "VGG
63	45: ::	3	DTMV.CEEWO WNCVQT
64	46522	3	CEEWO WNCVQT
65	28725265	3	CF CRVGT.7B8O QT'Z'51: HQT*"RTGO KWO "VTCEVQTUQP.N[+
///	28727257	/	XCXNGEQXGT"/PQP/ECD'QPN["PQV"UJ QY P+

JD7X30 BENGAL BRUTE

TRACTOR REMOTE PORTS (STANDARD)

STANDARD SERIES TRACTOR

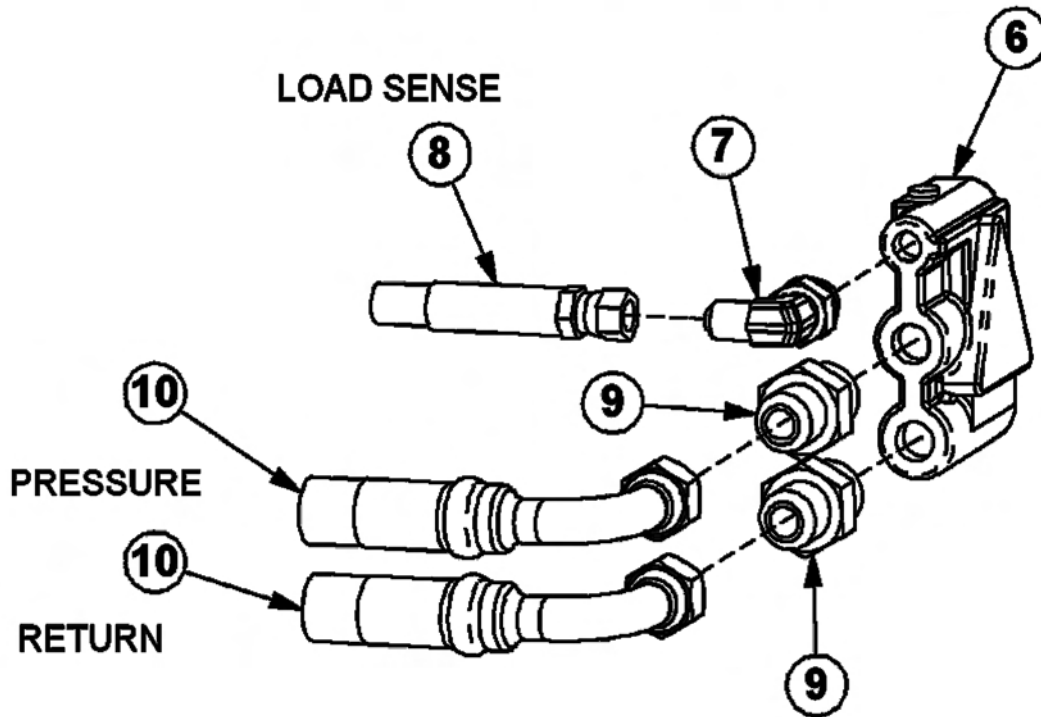

ITEM	PART NO.	QTY.	DESCRIPTION
8	/////	3	VTCEVQT" TGO QVGU*UWCP F CTF +
9	28725235	3	GNDQY .360 O "QTD"Z"7 B80L
:	28722622	3	J QUG.3 16\$Z"52\$
	28722572	3	J QUG.3 16\$Z"48\$
;	55685	4	CF CRVGT.440 O "QTD"Z"3 140L
32	56834	4	J QUG.3 14\$Z"56

TRACTOR REMOTE PORTS (PREMIUM)

PREMIUM SERIES TRACTOR

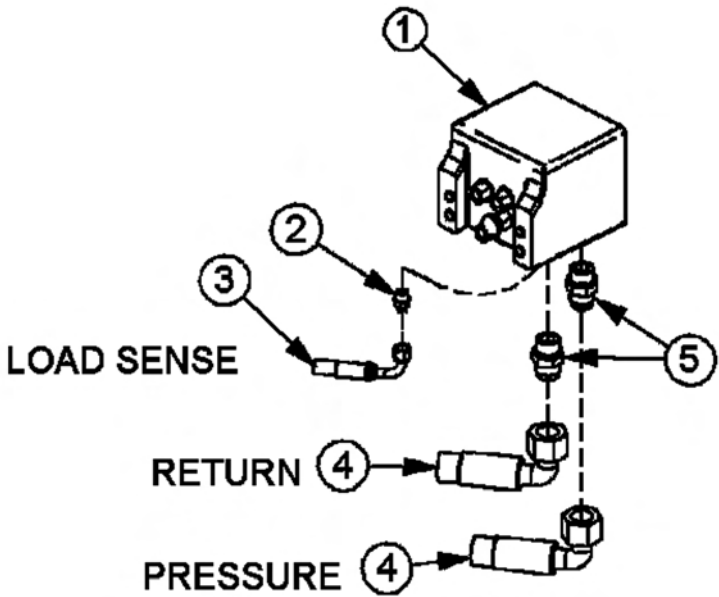

ITEM	PART NO.	QTY.	DESCRIPTION
3	/////	3	VTCEVQT" TGO QVGU
4	2872528;	3	CF CRVGT.360 O "QTD"Z"51: OL
5	28722489	3	J QUG.316\$Z"52\$
6	2872248;	4	J QUG.314\$Z"62\$
7	28725234	4	CF CRVGT.490 O "QTD"Z"516OL

CABLE (MANUAL) LIFT VALVE BREAKDOWN - 06502038

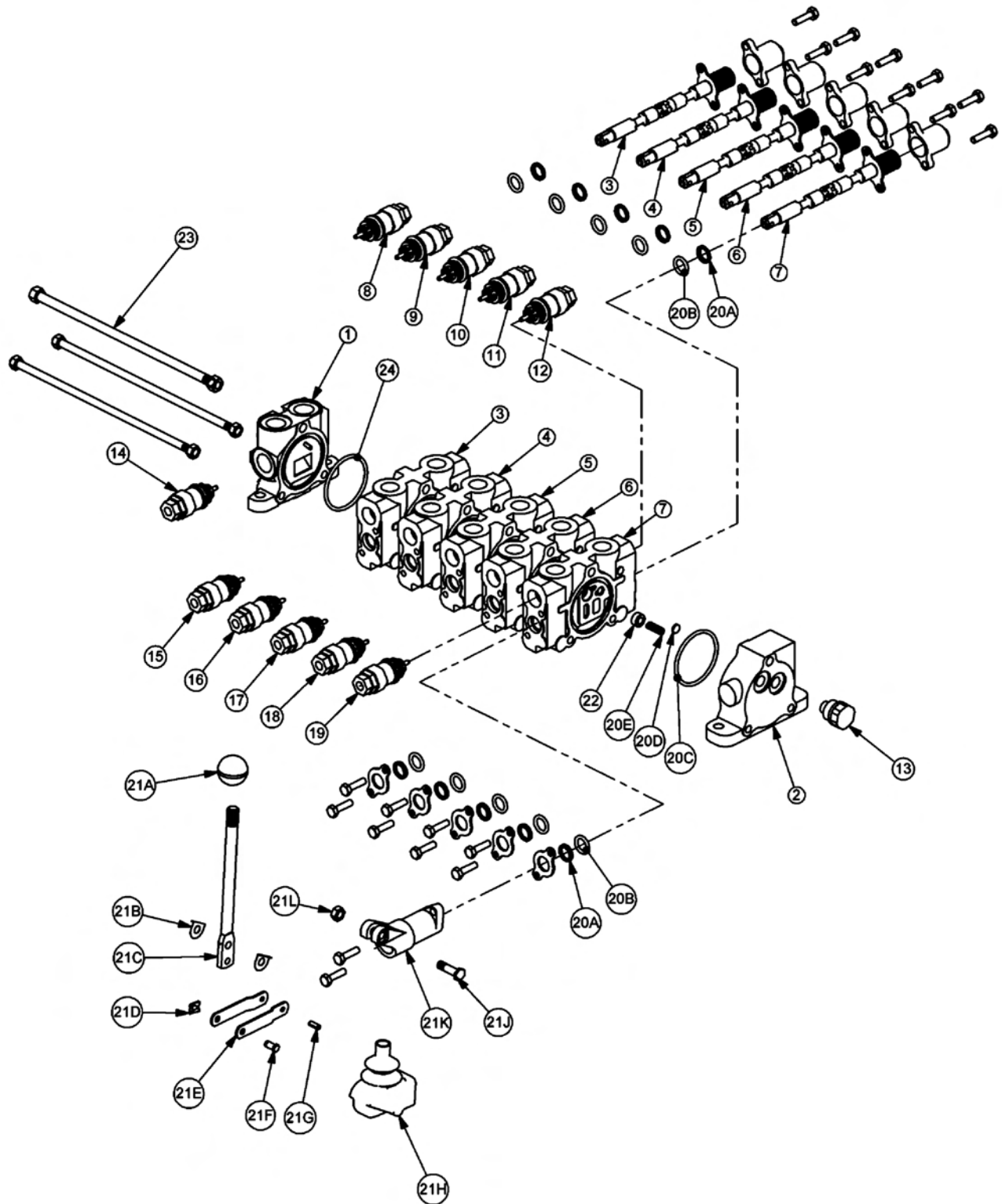

CABLE (MANUAL) LIFT VALVE BREAKDOWN - 06502038

Continued...

ITEM	PART NO.	QTY.	DESCRIPTION
3	537; 7	3	R NGV"GP F "EQXGT
4	537; 6	3	GP F "EQXGT ."NQCF "UGP UG
5	537; 9	3	XCNXG"UGE VIQP "F QWDNG"CEVRI . "EGP VGT"URTRI +
6	537; 9	3	XCNXG"UGE VIQP "F QWDNG"CEVRI . "EGP VGT"URTRI +
7	537; 9	3	XCNXG"UGE VIQP "F QWDNG"CEVRI . "EGP VGT"URTRI +
8	537; :	3	XCNXG"UGE VIQP "F QWDNG"CEVRI . "EGP VGT"URTRI ."O GVTGF +
9	537; 9	3	XCNXG"UGE VIQP "F QWDNG"CEVRI . "EGP VGT"URTRI +*TGO QXG"UJ WVNNG"FRUE+
:	VH6434	3	TGNKGH"XCNXG."422"RUK
;	VD3239M	3	TGNKGH"XCNXG."4372"RUK
32	VD3239L	3	TGNKGH"XCNXG."3: 22"RUK
33	287242; ;	3	TGNKGH"XCNXG."4622"RUK
34	447; :	3	TGNKGH"XCNXG."722"RUK
35	2872528:	3	%8"Q/TRI "RNW
36	8V642;	3	%82"Q/TRI "RNW
37	287242: 7	3	TGNKGH"XCNXG."5222"RUK
38	VD3239H	3	TGNKGH"XCNXG."3722"RUK
39	VD3239H	3	TGNKGH"XCNXG."3722"RUK
3:	8V5; 2:	3	TGNKGH"XCNXG."4322"RUK
3;	447; :	3	TGNKGH"XCNXG."722"RUK
42	537; 5	7	XCNXG"UGC"NK"MQT"QP G"UGEVIQP +
	/////	4	Y RGT
	/////	4	Q/TRI "UO CNN
	/////	3	Q/TRI "NCTI G
	/////	3	UJ WVNNG"FRUE
	/////	3	URTRI
43	VD3239N	7	NGXGT"MK"MQT"QP G"UGEVIQP +
	/////	3	NGXGT"MP QD
	/////	3	NGXGT
	/////	4	NGXGT"Y CUJ GT
	/////	3	NGXGT"ENR
	/////	4	NK MCI G
	/////	3	NGXGT"RP
	/////	3	TQNN"RP
	/////	3	NGXGT"DQQV
	/////	3	NGXGT"DQNV
	/////	3	NGXGT"FWUVEQXGT
	/////	3	NGXGT"PP WW
44	53825	7	EQO RGP UC VQT
45	VD3239X	3	VGTQF "MK
46	46436	3	Q/TRI ."NCTI G

CABLE (MANUAL) LIFT VALVE BREAKDOWN - 06502057

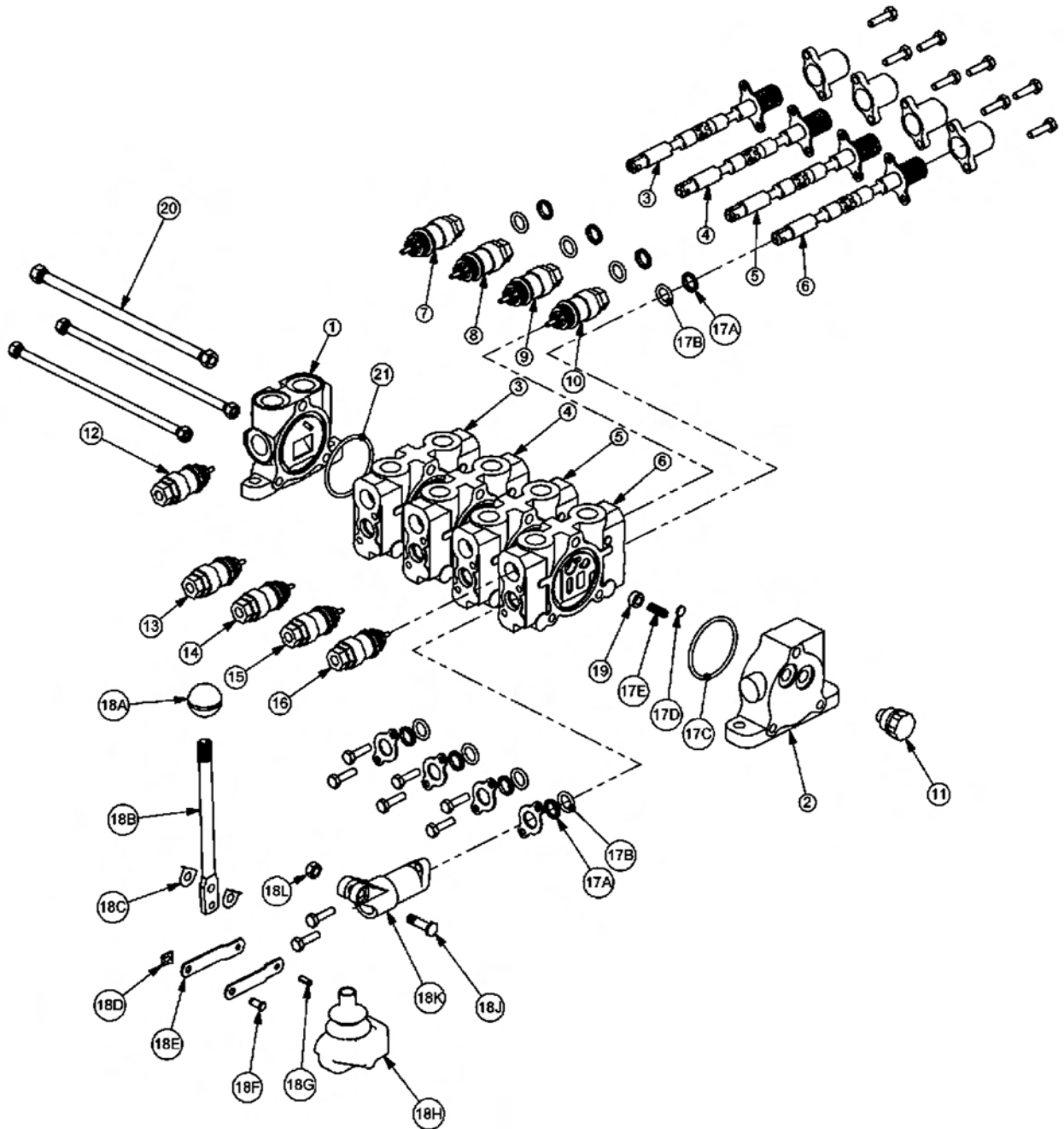

CABLE (MANUAL) LIFT VALVE BREAKDOWN - 06502057

Continued...

ITEM	PART NO.	QTY.	DESCRIPTION
3	537; 7	3	R NGV"GP F "EQXGT
4	537; 6	3	GP F "EQXGT ."NQCF "UGP UG
5	537; 9	3	XCNXG"UGE VIQP "F QWDNG"CEV R I . "EGP VGT"URT R I +
6	537; 9	3	XCNXG"UGE VIQP "F QWDNG"CEV R I . "EGP VGT"URT R I +
7	53822	3	XCNXG"UGE VIQP "F QWDNG"CEV R I . "F G VGP V" "HNQC V+
8	537; :	3	XCNXG"UGE VIQP "F QWDNG"CEV R I . "EGP VGT"URT R I . "O G VGT GF +*T GO QXG"UJ W VNG" F R U E+
9	VH6434	3	TGNKGH"XCNXG."422"RUK
:	VD3239M	3	TGNKGH"XCNXG."4372"RUK
;	VD3239L	3	TGNKGH"XCNXG."3: 22"RUK
32	287242; ;	3	TGNKGH"XCNXG."4622"RUK
33	2872528:	3	%8"Q/T R I "RNW
34	8V642;	3	%82"Q/T R I "RNW
35	287242: 7	3	TGNKGH"XCNXG."5222"RUK
36	VD3239H	3	TGNKGH"XCNXG."3722"RUK
37	VD3239H	3	TGNKGH"XCNXG."3722"RUK
38	8V5; 2:	3	TGNKGH"XCNXG."4322"RUK
39	537; 5	6	XCNXG"UGC N"MK" "HQT"QP G"UGE VIQP +
	/////	4	Y RGT
	/////	4	Q/T R I "UO CNN
	/////	3	Q/T R I "NCTI G
	/////	3	UJ W VNG" F R U E
	/////	3	URT R I
3:	VD3239N	6	NGXGT"MK" "HQT"QP G"UGE VIQP +
	/////	3	NGXGT"MP QD
	/////	3	NGXGT
	/////	4	NGXGT"Y CU GT
	/////	3	NGXGT"ENR
	/////	4	N R MCI G
	/////	3	NGXGT"R R
	/////	3	TQNN"R R
	/////	3	NGXGT"DQ QV
	/////	3	NGXGT"DQ NV
	/////	3	NGXGT" F WUV"EQXGT
	/////	3	NGXGT" P W W
3;	53825	6	EQO RGP UC VQT
42	VD3239W	3	VIG" TQF "MK
43	46436	3	Q/T R I . "NCTI G

CABLE (MANUAL) LIFT VALVE BREAKDOWN - 06502093

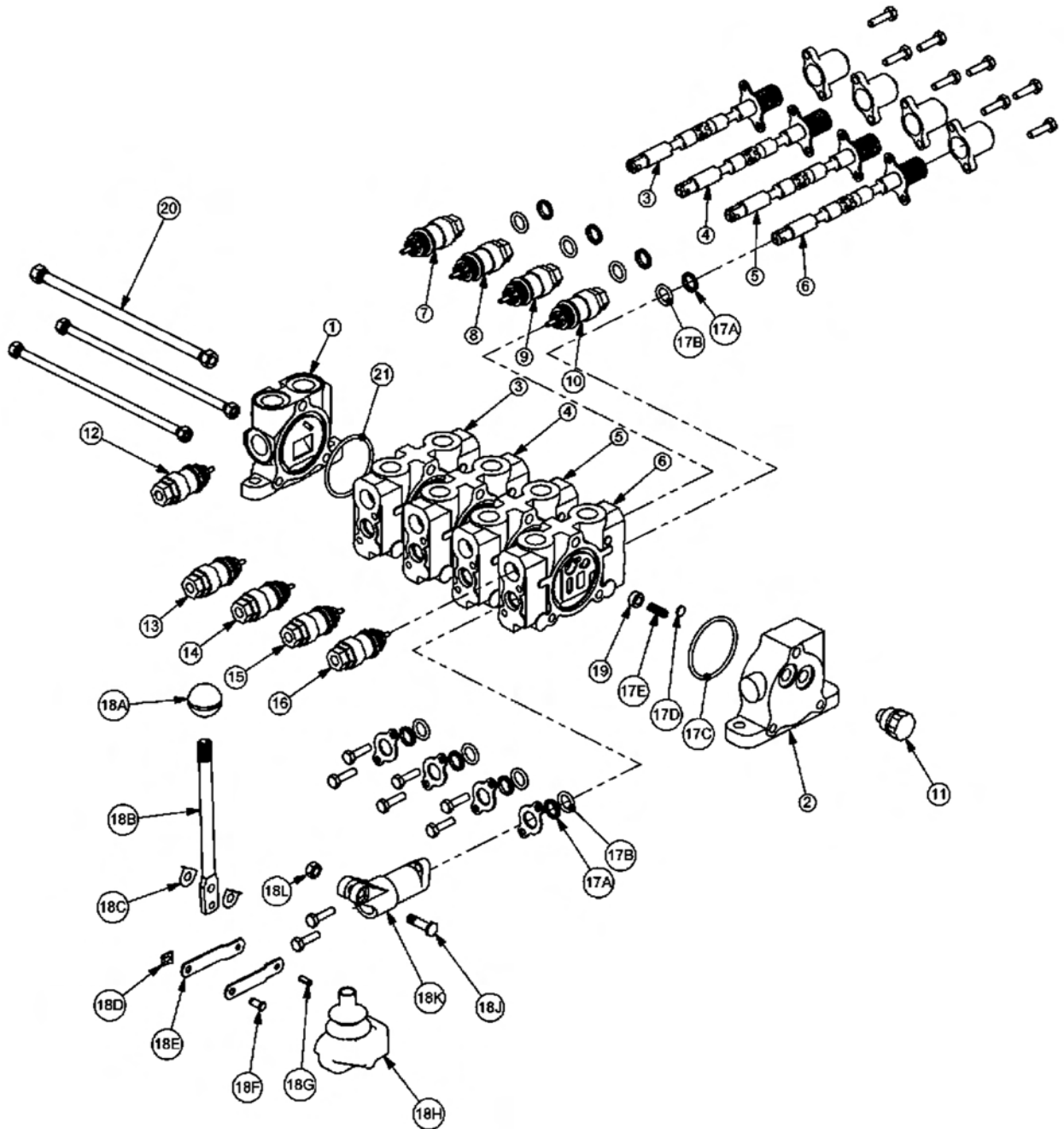

CABLE (MANUAL) LIFT VALVE BREAKDOWN - 06502093

Continued...

ITEM	PART NO.	QTY.	DESCRIPTION
3	537; 7	3	R NGV"GP F "EQXGT
4	537; 6	3	GP F "EQXGT ."NQCF "UGP UG
5	537; 9	3	XCNXG"UGE VIQP "F QWDNG"CEV R I . "EGP VGT"URT R I +
6	537; 9	3	XCNXG"UGE VIQP "F QWDNG"CEV R I . "EGP VGT"URT R I +
7	537; 9	3	XCNXG"UGE VIQP "F QWDNG"CEV R I . "EGP VGT"URT R I +
8	537; :	3	XCNXG"UGE VIQP "F QWDNG"CEV R I . "EGP VGT"URT R I . "O G VGT"GF +*T GO QXG"UJ W VVNG" F R U E +
9	VH6434	3	TGNKGH"XCNXG."422"RUK
:	VD3239M	3	TGNKGH"XCNXG."4372"RUK
;	VD3239L	3	TGNKGH"XCNXG."3: 22"RUK
32	287242; ;	3	TGNKGH"XCNXG."4622"RUK
33	2872528:	3	%8"Q/T R I "RNW
34	8V642;	3	%82"Q/T R I "RNW
35	287242: 7	3	TGNKGH"XCNXG."5222"RUK
36	VD3239H	3	TGNKGH"XCNXG."3722"RUK
37	VD3239H	3	TGNKGH"XCNXG."3722"RUK
38	8V5; 2:	3	TGNKGH"XCNXG."4322"RUK
39	537; 5	6	XCNXG"UGC N"MK" *HQT"QP G"UGE VIQP +
	/////	4	Y RGT
	/////	4	Q/T R I "UO CNN
	/////	3	Q/T R I "NCTI G
	/////	3	UJ W VVNG" F R U E
	/////	3	URT R I
3:	VD3239N	6	NGXGT"MK" *HQT"QP G"UGE VIQP +
	/////	3	NGXGT"MP QD
	/////	3	NGXGT
	/////	4	NGXGT"Y CUJ GT
	/////	3	NGXGT"ENR
	/////	4	N R MCI G
	/////	3	NGXGT"R R
	/////	3	TQNN"R R
	/////	3	NGXGT"DQQV
	/////	3	NGXGT"DQNV
	/////	3	NGXGT" F WUV"EQXGT
	/////	3	NGXGT" P W W
3;	53825	6	EQO RGP UC VQT
42	VD3239W	3	VIG" TQF "MK
43	46436	3	Q/T R I . "NCTI G

PUMP DRIVESHAFT ASSEMBLY

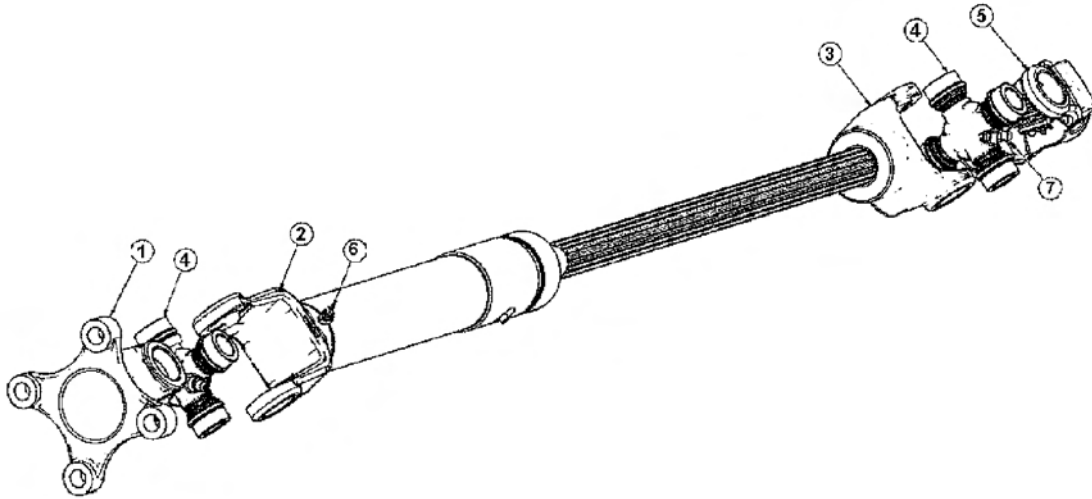

ITEM	PART NO.	QTY.	DESCRIPTION
b/////	56; ; ;	3	FTK&GUJ CHV.WLQ&P V
3	28727226	3	[QMG'RWNNG]
4	28727227	3	UNGGXG
5	28727228	3	UJ CHV
6	28727229	4	ETQUU
7	2872722:	3	[QMG'FTK&G
8	8V5425	3	I TGCUG\ GTM.3 1/2" 67a
9	8V5429	5	I TGCUG\ GTM.3 1/2" UVT

POLYCARBONATE SAFETY WINDOW (STANDARD)

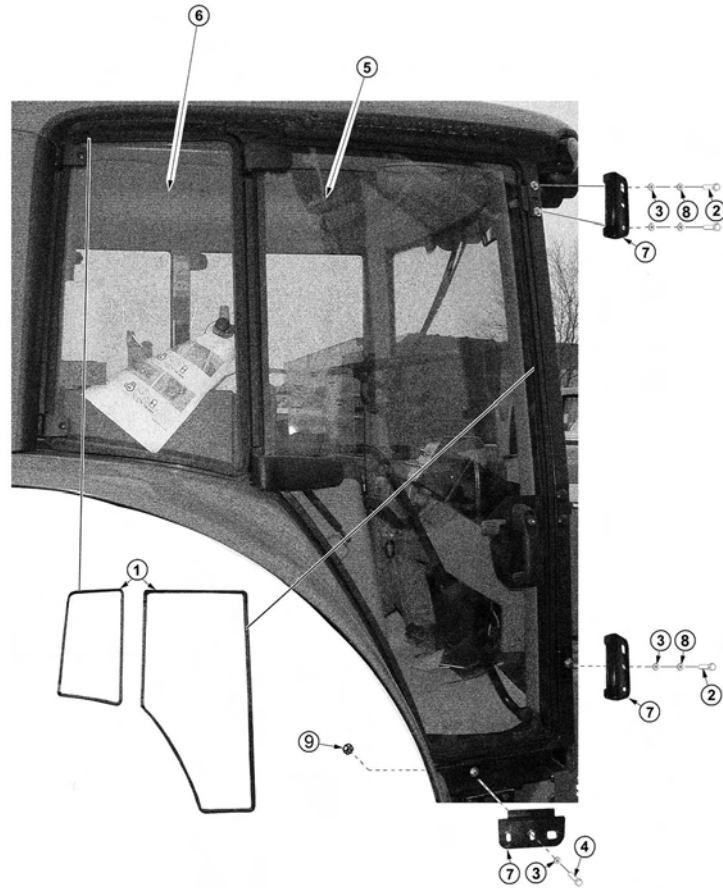

ITEM	PART NO.	QTY.	DESCRIPTION
3	53; 87	44	VTIO "UGCN"*HGGV+
4	4972;	5	ECRUETGY .: O O "Z"42O O *3047R+
5	44237	8	HNCVY CUI GT.7B8\$
6	437; 3	3	ECRUETGY .7B8\$Z"3/316\$.PE
7	286; 2227	3	RQN[ECTD.HFO F.FQQT.TJ
8	286; 2249	3	RQN[ECTD.HFO F.TGCT.TJ
9	28742262	5	DTCEMGV.TGVCR R I
:	8V483;	5	NQEMY CUI GT.: O O
;	43799	3	P[NQEMP WW.7B8\$.PE

POLYCARBONITE SAFETY WINDOW (PREMIUM)

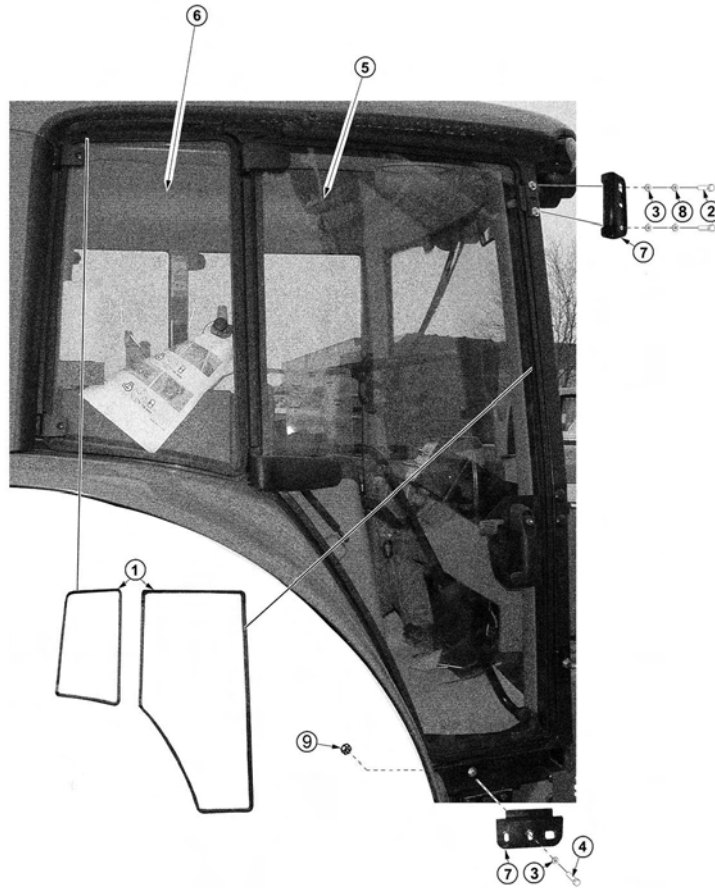

ITEM	PART NO.	QTY.	DESCRIPTION
3	53; 87	44	VTIO "UGCN" *HGGV+
4	4972;	4	ECRUETGY .: O O "Z" 42O O .3047R
5	44237	7	HNCVY CUI GT. 7B8\$
6	437; 3	3	ECRUETGY .7B8\$Z "3/316\$.PE
7	286; 2229	3	RQN[ECTD.HFO F.FQQT.TJ
8	286; 2249	3	RQN[ECTD.HFO F.TGCT.TJ
9	28742262	4	DTCEMGV.TGVCR R I
:	8V483;	4	NQEMY CUI GT.: O O
;	43799	3	P[NQEMP WW.7B8\$.PE

NOTES

POLYCARBONATE SAFETY WINDOW (PANORAMIC)

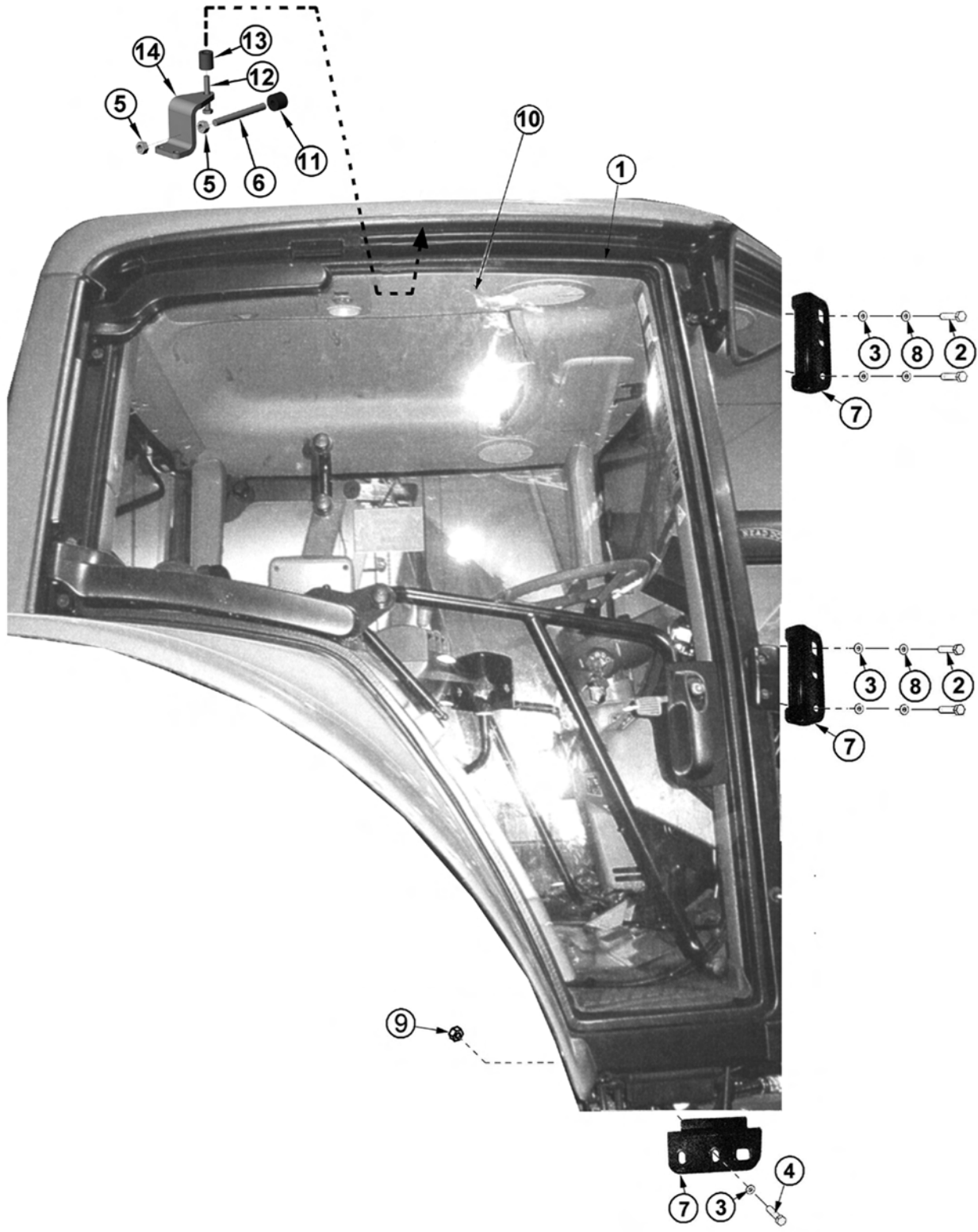

POLYCARBONATE SAFETY WINDOW (PANORAMIC)

Continued...

ITEM	PART NO.	QTY.	DESCRIPTION
3	53; 87	42	VTKO "UGCN" *HGGV+
4	4972;	6	ECRUETGY .: O O 'Z' 42O O *3047R+
5	44237	7	HNCVY CUI GT. 7B8\$
6	437: 3	3	ECRUETGY .7B8\$Z'3/316\$.PE
7	43797	4	J GZ 'P WW.7B8\$.PE
8	5569:	3	TQF .VJ TGCF GF .7B8\$Z'5\$
9	28742262	5	DTMV.IF .RQN .TGVCIP
:	8V483;	6	NQEMY CUI GT.: O O
;	43799	3	P [NQEMP WW.7B8\$.PE
32	286; 2257	3	RQN ECTD.HFO F .RCP .IF 8/9252
33	55699	3	XKDTCVIQP "KQNCVQT.7B8\$.PE
34	28752747	3	ECRUETGY .8O O 'Z' 62O O *30R+I T: 0
35	53256	3	URCEGT.7E \$QF 'Z' 5E \$F 'Z' 516\$
36	2863248;	3	DTMV.UHV 'UETP .DQVVQO
37	28759227	3	CFJ GUK&G.Y VJ T 'UVTR.DNM*P QV'UI QY P+
38	44867	3	F GECN.RQN ECTDQPCVG'Y K F QY 'P QV'UI QY P+

SAFETY SCREEN, WOC

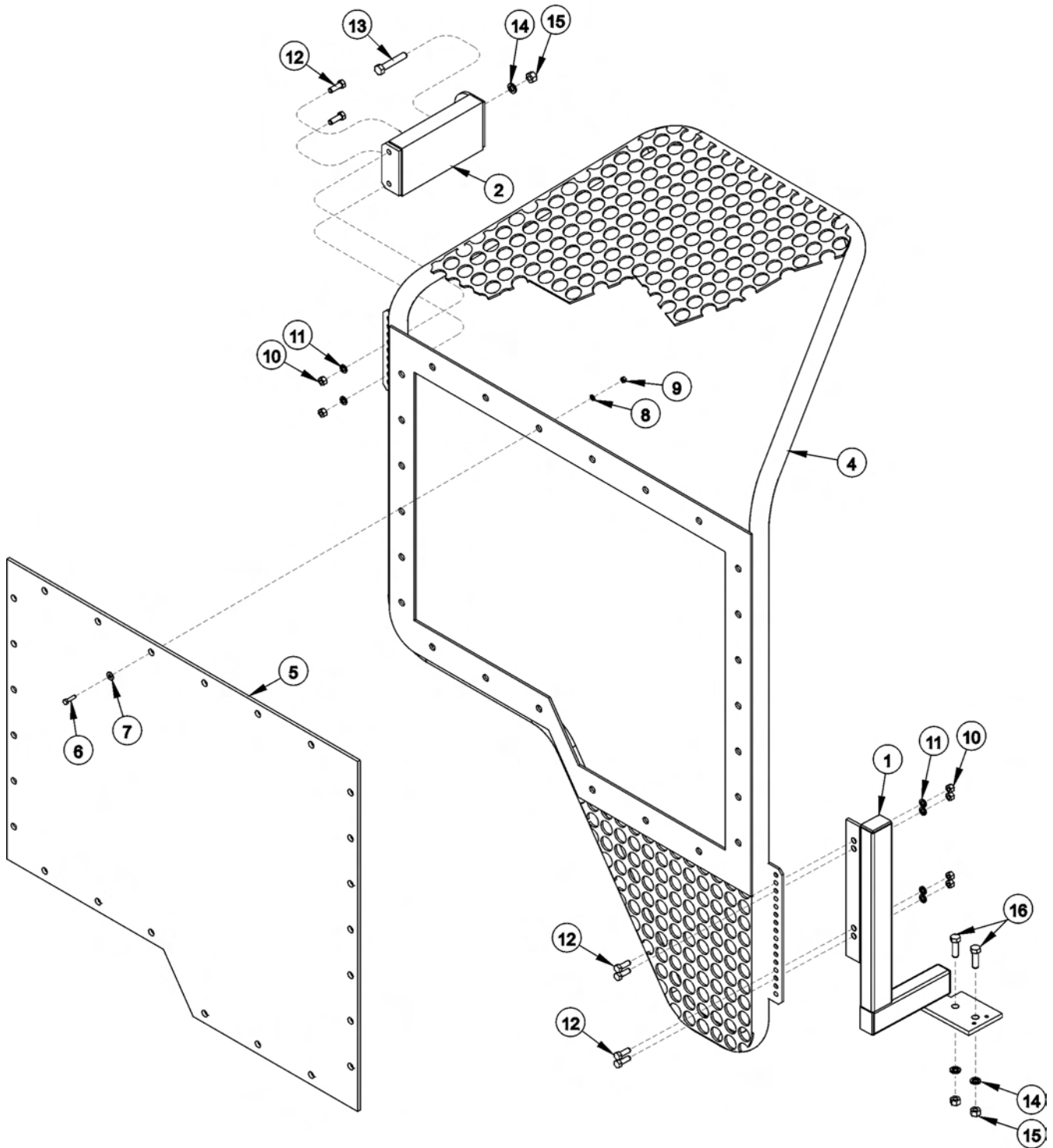

SAFETY SCREEN, WOC

Continued...

ITEM	PART NO.	QTY.	DESCRIPTION
3	569; 3	3	UCHGV["UETGGP "DTCEMGV.NQY GT
4	54876	3	UCHGV["UETGGP "DTCEMGV.WRRGT
5	54868	3	UCHGV["UETGGP "CUUGO DN[
6	""54859	3	""UCHGV["UETGGP
7	""5485:	3	""NGZCP"Y R F QY
8	""437: 3	47	""ECRUETGY .7B86"Z"3"3166"PE
9	""44237	47	""HNCVY CUJ GT.7B86
:	""43; : 9	47	""NQEMY CUJ GT.7B86
;	""43797	47	""J GZ" P W.7B86"PE
32	43947	8	J GZ" P W.346"PE
33	43; : 2	8	NQEMY CUJ GT.346
34	43953	8	ECRUETGY .346"Z"3"346"PE
35	439; :	3	ECRUETGY .71 6"Z"5"346"PE
36	43; : 4	5	NQEMY CUJ GT.71 6
37	43997	5	J GZ" P W.71 6"PE
38	439: 5	4	ECRUETGY .71 6"Z"46

FRONT 50 GALLON TANK MOUNT

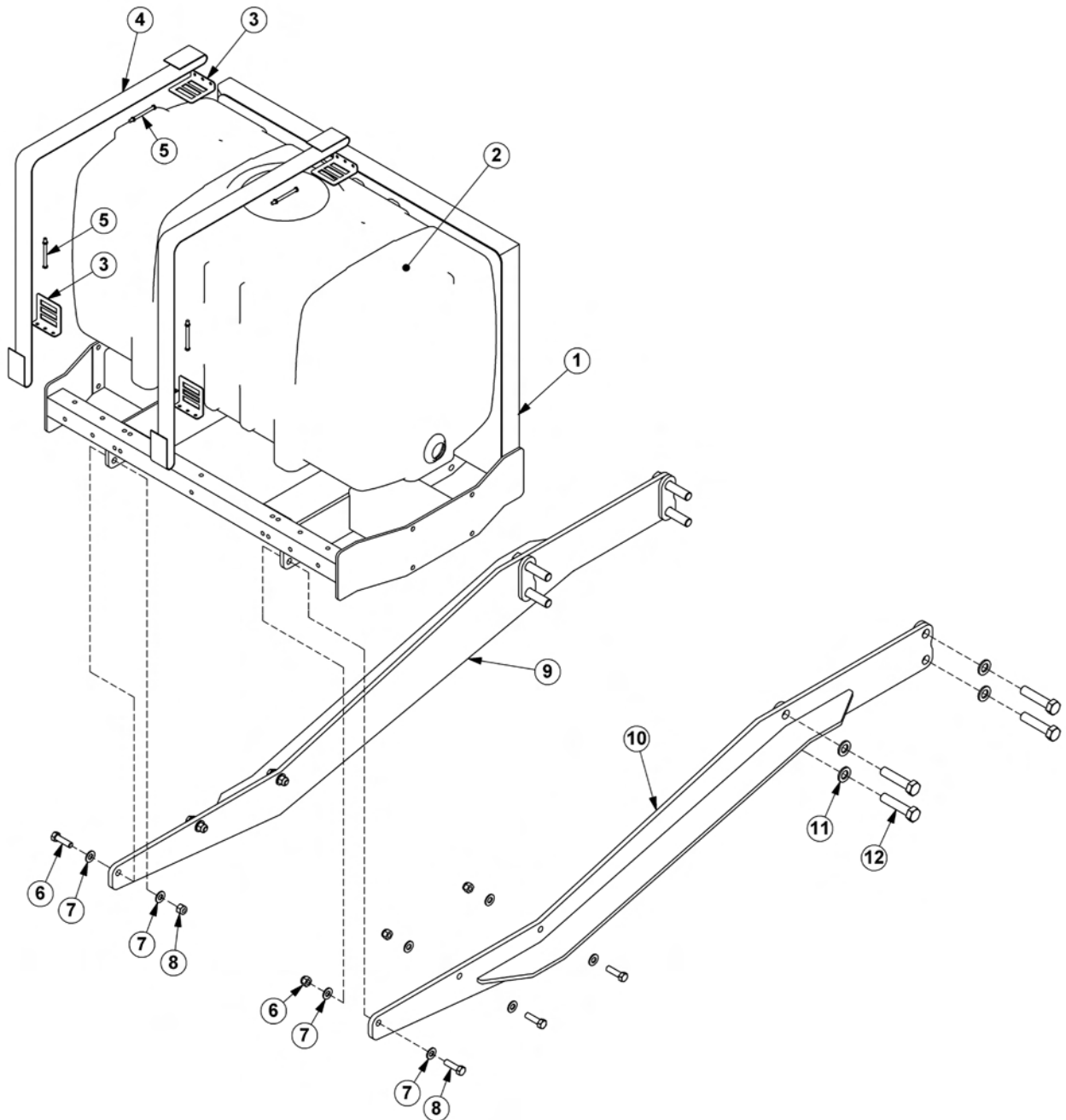

FRONT 50 GALLON TANK MOUNT

Continued...

ITEM	PART NO.	QTY.	DESCRIPTION
3	28592426	3	OP V.VCPMHFP V.72" CNNQP
4	28742564	3	VCPM72" CNNQP
5	28742565	6	CPEJ QT.UVTCR
6	28742567	4	UVTCR
7	28742566	6	DQNV("P WW.UVTCR.VCP M
8	43949	8	P[NQEMP WW.34\$.PE
9	28755226	34	HNCVY CUI GT.34\$.UCG
:	43954	8	ECRUETGY .34\$Z'3/516\$.PE
;	28592428	3	OP V.VCPMTJ
32	28592427	3	OP V.VCPMNI
33	55: : 2	:	HNCVY CUI GT.516\$.UCG
34	5292:	:	ECRUETGY .420 O "Z"; 20 O .40R

WHEEL WEIGHT - STEEL DISH

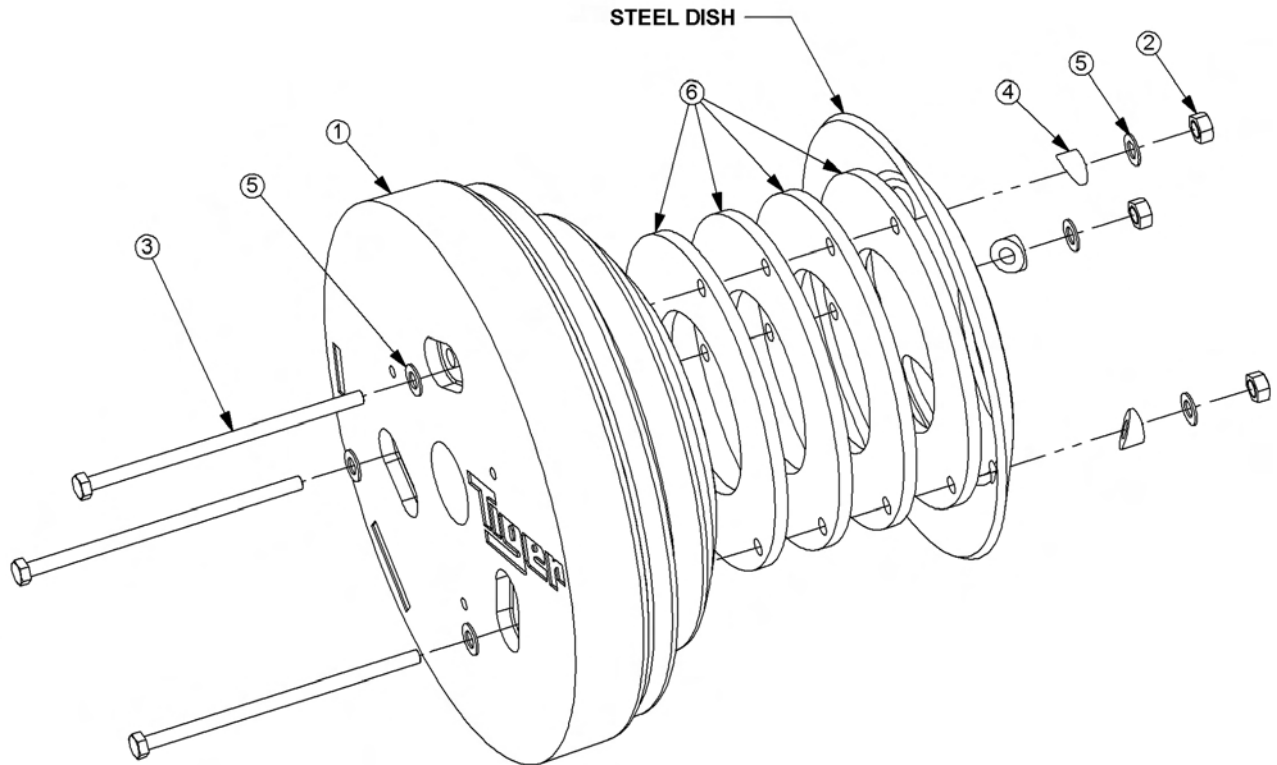

ITEM	PART NO.	QTY.	DESCRIPTION
3	54837	3	Y J GGN"Y GK J V.3922%
4	28753222	5	J GZ" P WW.9B8.PE.I T:
5	28752435	5	ECRUETGY .91 \$Z"38\$.PE.I T:
6	53957	5	URCEGT.DQNV.Y J N"Y J V*"RTGO KWO "VTCEVQTU"QPNI +
7	28755222	8	HNCVY CUI GT.91E .I T:
8	28622632	6	URCEGT.TU

WHEEL WEIGHT - CAST DISH

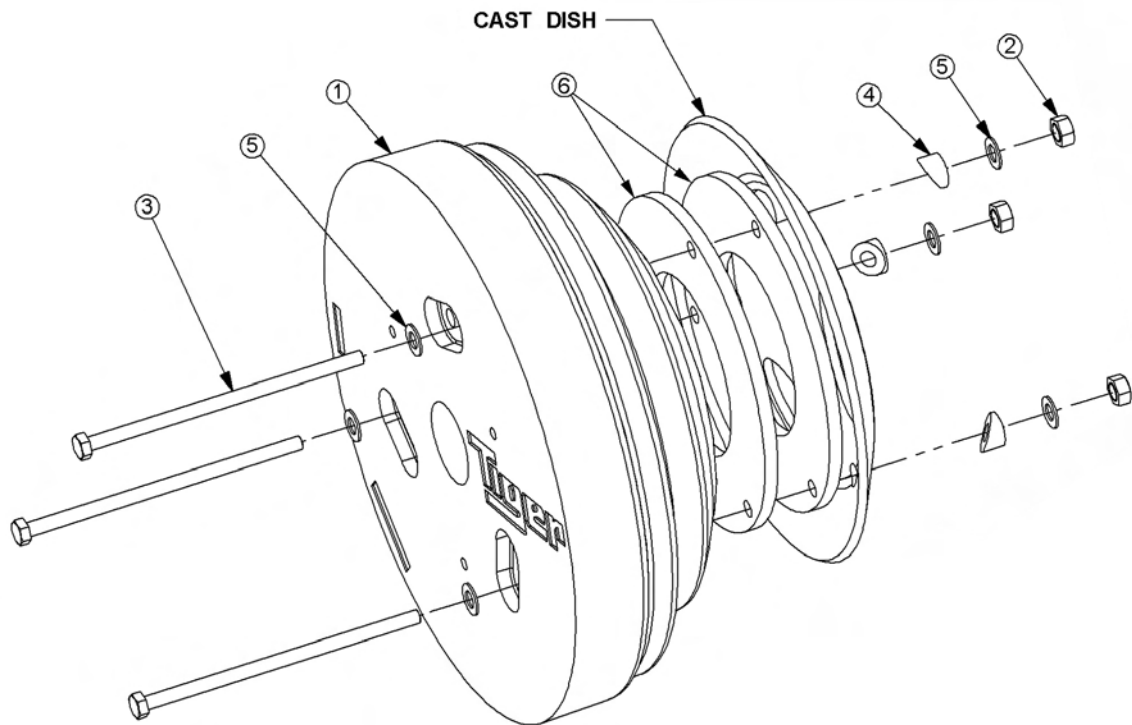

ITEM	PART NO.	QTY.	DESCRIPTION
3	54837	3	Y J GGN"Y GK J V.3922%
4	28753222	5	J GZ'P WW.9B8.PE.I T:
5	2875243;	5	ECRUETGY .91 \$Z"3; /344\$.PE.I T:
6	28652343	5	URCEGT.ECUV'TIO
7	28755222	8	HNCVY CUI GT.9E .I T:
8	28622632	4	URCEGT.TU

JD7X30 BENGAL BRUTE

NOTES

COMMON LEGAL REAR STOW

PARTS SECTION

PART NAME INDEX

RCTVUQTF GT&I 'I W&G	6
DGPI CN'DTWG'J QUG'TQW&I	7
NGI CN'TGCT'UVQY 'DQO 'CUU	8
NGI CN'TGCT'UVQY 'DQO 'J [F 'CUU	:
DQO TGUV/'DGPI CN'DTWG	32
DQO TGUV/'RCP VJ GT	34
NGI CN'TGCT'UVQY 'TVT['R&QV'CUU	36
NGI CN'TGCT'UVQY 'HCK'NR&QV'CUU	38
72R 'TQVCT['O QY GT'CUUGO DN	3:
82R 'TQVCT['O QY GT'CUUGO DN	42
72R 'TQVCT['MP &GU'CPF 'F KU	44
72R 'TQVCT['DNCF G'DCT'CPF 'MP &GU	45
82R 'TQVCT['MP &GU'CPF 'F KU	46
82R 'TQVCT['DNCF G'DCT'CPF 'MP &GU	47
72R 'HCK'NF T&G'CUUGO DN	48
72R 'HCK'NO QY GT'CUUGO DN	4:
72R 'HCK'NO QY GT'CUU . 'RCU/VJ TQW J 'MP &GU	52
85R 'HCK'NF T&G'CUUGO DN	54
85R 'HCK'NO QY GT'CUUGO DN	56
5R 'Z'32R 'Y GNF GF 'E[NR F GT'DTGCMF QY P	58
5R 'Z'3: R 'Y GNF GF 'E[NR F GT'DTGCMF QY P	59
5/3 4R 'Z'42R 'Y GNF GF 'E[NR F GT'DTGCMF QY P	5:
6R 'Z'; R 'Y GNF GF 'E[NR F GT'DTGCMF QY P	5;
6R 'Z'42R 'Y GNF GF 'E[NR F GT'DTGCMF QY P	62
P QVGU'3	63
EQQNGT'CUUGO DN	64
TQVCT['O QY GT'UR F NG'CUUGO DN	66
RWO R'CPF 'I T&N'I WCTF 'QRVQP	68
TGUGT'XQT'VCP M&N'VT'CUUGO DN	69
7'URQQN'NGEVTQP &'XCXG/'DGPI CN'DTWG	6:
7'URQQN'NGEVTQP &'XCXG/'RCP VJ GT	72
HTQP VJ [F TCW&'RWO R	74
72R 'CPF'82R 'TQVCT['O QVQT'DTGCMF QY P	76
72R 'CPF'85R 'HCK'NO QVQT'DTGCMF QY P	78
O CP WCN'NHV'XCXG'UY &EJ 'DQZ	7:
O CP WCN'NHV'XCXG'UEJ GO CV&	7;
NGEVTQP &'NHV'XCXG'UY &EJ 'DQZ	82
NGEVTQP &'NHV'XCXG'UEJ GO CV&'TGCT'UVQY	83
NGEVTQP &'NHV'XCXG'Y &I 'F KI TCO	84
DQO 'VTCXGN'NQEM	85

COMMON LRS

PART NAME INDEX

UGNGE VQT"XCNXG"UEJ GO C VKE	86
DT CMG"XCNXG"CUUGO DN[87
DT CMG"XCNXG"J [F T C W N E "UEJ GO C VKE	88
J [F T C W N E "VTQWDNGUJ QQV R I "I W F G	89
GNGE V T E C N "VTQWDNGUJ QQV R I "I W F G	8:
VTQWDNGUJ QQV R I	8;
VTQWDNGUJ QQV R I "E Q P V R W G F	92
ENGCP "E W V G T "J G C F	93
ENGCP "E W V G T "CUUGO DN[94
ENGCP "E W V G T "Q R G T C V R P	95
ENGCP "E W V G T "Q R G T C V R P "E Q P V R W G F	96
ENGCP "E W V G T "O C R V G P C P E C	97
ENGCP "E W V G T "D N C F G "C P F "V G G V J "R C T V U	98
E C T D E G "V R "T G R N C E G O G P V	99
P Q V G U "4	9:
H K T "G "U W R R T G U I Q P "U U V G O	9;
H K T "G "U W R R T G U I Q P "5 / R Q R V O Q W P V	: 2
H K T "G "U W R R T G U I Q P "H T Q P V O Q W P V	: 4
H K T "G "U W R R T G U I Q P "U U V G O "G N G E V T E C N "UEJ GO C VKE	: 6
Y G V E W W	: 7
Y G V E W W "72 "I C N N Q P "V C P M "5 R P V O Q W P V	: 8
Y G V E W W "322 "Q T "372 "I C N N Q P "V C P M "5 R P V O Q W P V	: 9
Y G V E W W "5 R P V R N W O D R I "72 R "O Q Y G T U	::
Y G V E W W "5 R P V R N W O D R I "N C T I G O Q Y G T U	: 2
Y G V E W W "H T Q P V R N W O D R I "72 R "O Q Y G T U	: 4
Y G V E W W "H T Q P V R N W O D R I "N C T I G O Q Y G T U	: 6
Y G V E W W "72 R "U R T C [G T "J G C F "C U U G O D N [: 8
Y G V E W W "82 R "U R T C [G T "J G C F "C U U G O D N [::
Y G V E W W "E C D N G U	322

PARTS ORDERING GUIDE

The following instructions are offered to help eliminate needless delay and error in processing purchase orders for the equipment in this manual.

1. The Parts Section is prepared in logical sequence and grouping of parts that belong to the basic machine featured in this manual. Part Numbers and Descriptions are given to help locate the parts and quantities required.
2. The Purchase Order must indicate the **Name and Address** of the person or organization ordering the parts, **who should be charged**, and if possible, the **serial number of the machine** for which the parts are being ordered.
3. The purchase order must clearly list the **quantity of each part**, the complete and correct **part number**, and the basic **name of the part**.
4. The manufacturer reserves the right to substitute parts where applicable.
5. Some parts may be unlisted items which are special production items not normally stocked and are subject to special handling. Request a quotation for such parts before sending a purchase order.
6. The manufacturer reserves the right to change prices without prior notice.

NOTE: When ordering replacement decals, refer to the part numbers and descriptions listed in the safety section in the front of this manual.



For maximum safety and to guarantee optimum product reliability, always use genuine **Tiger** replacement parts. The use of inferior replacement parts may cause premature or catastrophic failure which could result in serious injury or death.

Direct any questions regarding parts to:

Tiger Corporation
3301 N. Louise Ave.
Sioux Falls, SD 57107
1-800-843-6849
1-605-336-7900

BENGAL BRUTE HOSE ROUTING

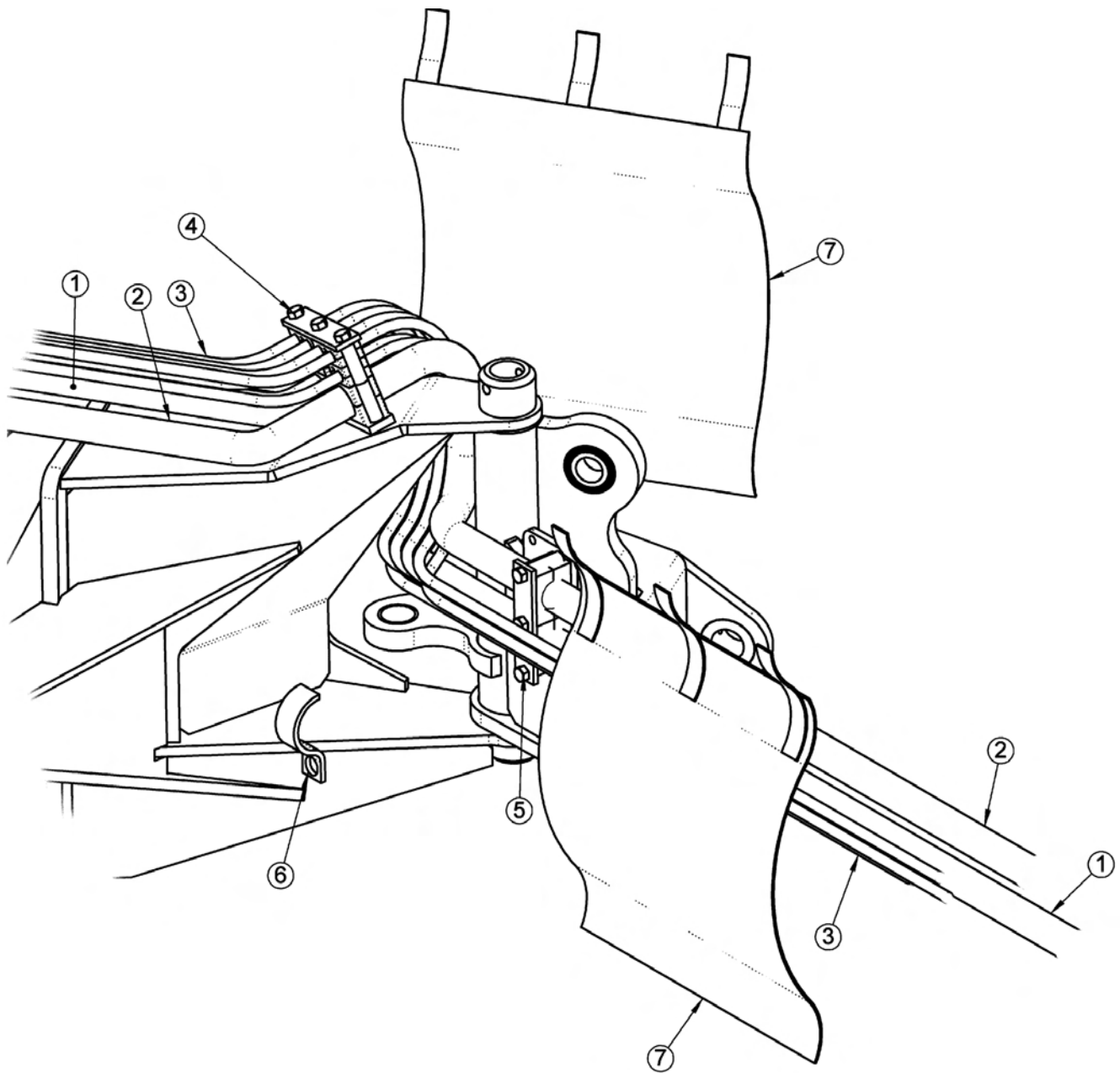

ITEM	PART NO.	QTY.	DESCRIPTION
3	"/"/"/	3	3\$J QUG'VQ'O C R 'DQQO "NQY GT"VWDG
4	"/"/"/	3	3\$J QUG'VQ'O C R 'DQQO "WRRGT"VWDG
5	"/"/"/	8	3 K\$J QUG'VQ'O C R 'DQQO
6	287272: 7	3	ENCOR'MK
7	57353	3	ENCOR'MK
8	VD5234	3	ENCOR
9	28727243	4	J QUG'EQXGT

COMMON LRS

LEGAL REAR STOW BOOM ASSY

NOTES

1. IMPORTANT: ALIGN GREASE HOLE IN BEARING (ITEMS 4 & 5) WITH GREASE ZERK IN BOOM. MAINTAIN ALIGNMENT DURING BEARING INSTALLATION
2. "X" JOINTS HAVE TWO BEARINGS

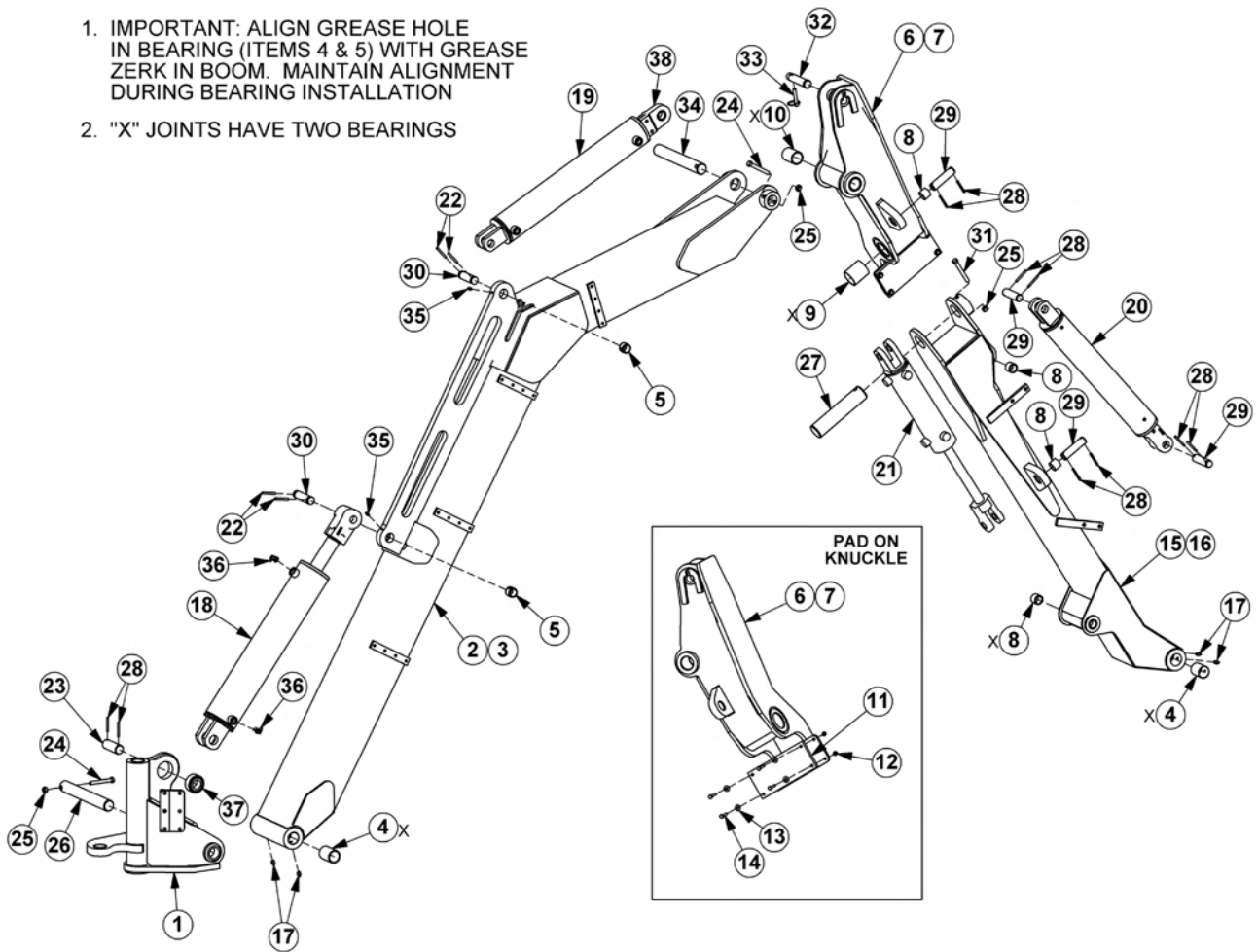

LEGAL REAR STOW BOOM ASSY

Continued...

ITEM	PART NO.	QTY.	DESCRIPTION
3	28922239	/	UY KGN'CUUJ ", TGHGT"VQ"VTCEVQT"O QWP V"MKV
4	28922253	3	O CR' DQOQO 'CTO 'CUUJ
5	28532235	3	O CR' DQOQO 'Y NFOPV
6	54543	6	DWUJ RPI .3/34R'Z"4
7	VD5232	4	DWUJ RPI .3R'
8	28922258	3	MP WEMNG'DQOQO 'CTO 'CUUJ
9	28532229	3	MP WEMNG'DQOQO 'Y NFOPV
:	28742298	6	DWUJ RPI .3R'Z"3
;	28742299	4	DWUJ RPI .4R'Z"3
32	28742633	4	DWUJ RPI .3/34R'Z"4/34
33	287422: 2	3	DQOQO "UVQR'RCF
34	43749	6	P[NQEMP WW.316.PE
35	44236	6	HNCVY CUJ GT.316
36	43754	6	ECRUETGY .316"Z"3/34
37	28922259	3	UGEQPFCT['DQOQO 'CTO 'CUUJ
38	2853222:	3	UGEQPFCT['DQOQO 'Y NFOPV
39	8V5933	6	I TGCUG\ GTM.316 \$PRV
3:	28723244	3	E[NR'FGT.6"Z"42
3;	28723246	3	E[NR'FGT.5/34"Z"42
42	28723245	3	E[NR'FGT.5"Z"3:
43	28723243	3	E[NR'FGT.5"Z"32
44	28759243	6	TQNNRRP .70 O
45	28642322	3	RRP .3/316"Z"5/71
46	438: :	4	ECRUETGY .918"Z"5/316.PE
47	43899	5	P[NQEMP WW.918.PE
48	28642244	3	RRP .3/314"Z"34/516
49	28642239	3	RRP .3/516"Z"1: /; 18
4:	VD3245	32	TQNNRRP .9154
4;	28642236	6	RRP .3"Z"5/71
52	VD3255	4	RRP .3"Z"5/34
53	438: ;	3	ECRUETGY .918"Z"5/314
54	VD3258	3	RRP .3"Z"6/3318
55	VH365	3	N[PEJ 'RRP .918"Z"4
56	28642237	3	RRP .3/314"Z"33/516
57	8V5924	4	I TGCUG\ GTM.316
58	54: 32	4	GNDQY .34QTD"Z"51: O1; 2"CF L
59	/////	/	URJ GTIECN'DGCTRPI
5:	VD5255	3	ENGXRUY IURJ GTIECN'DGCTRPI

COMMON LRS

LEGAL REAR STOW BOOM HYD ASSY

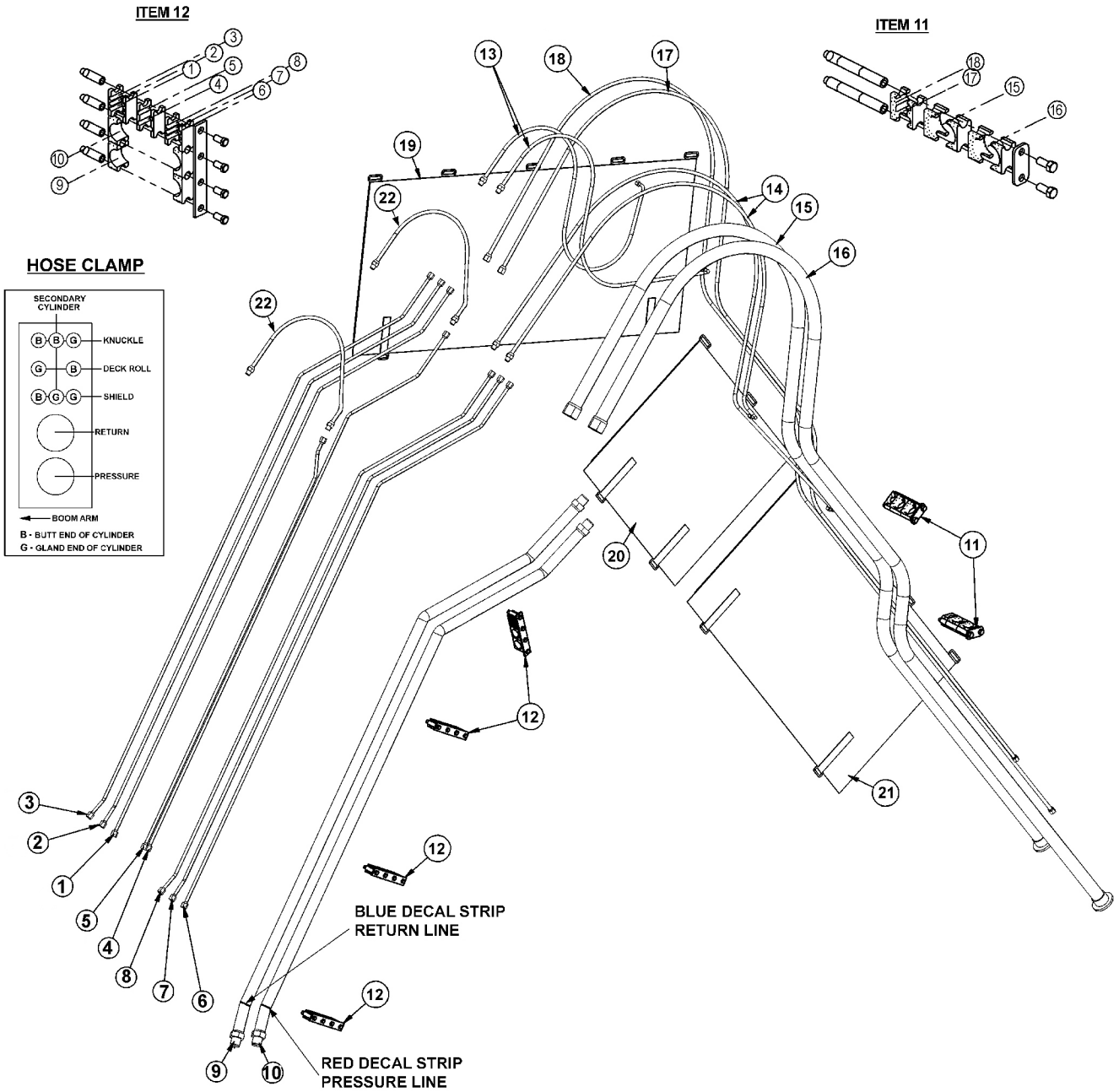

LEGAL REAR STOW BOOM HYD ASSY

Continued...

ITEM	PART NO.	QTY.	DESCRIPTION
1	06506013	1	PREFORMED TUBE #1
2	06506014	1	PREFORMED TUBE #2
3	06506015	1	PREFORMED TUBE #3
4	06506016	1	PREFORMED TUBE #4
5	06506017	1	PREFORMED TUBE #5
6	06506018	1	PREFORMED TUBE #6
7	06506019	1	PREFORMED TUBE #7
8	06506020	1	PREFORMED TUBE #8
9	06506021	1	PREFORMED TUBE #9
10	06506022	1	PREFORMED TUBE #10
11	06505024	2	CLAMP KIT
12	06505019	4	CLAMP KIT
13	06500152	2	HOSE, 1/4" X 66"
14	06500153	2	HOSE, 1/4" X 70"
15	06500154	1	HOSE, 1" X 141"
16	06500155	1	HOSE, 1" X 126"
17	06500156	1	HOSE, 1/4" X 143"
18	06500157	1	HOSE, 1/4" X 154"
19	06505020	1	HOSE WRAP
20	06505021	1	HOSE WRAP
21	06505022	1	HOSE WRAP

COMMON LRS

BOOMREST - BENGAL BRUTE

NOTE: FOR TRANSPORTING ON A FLATBED, THE FLAIL HEAD MUST BE STOWED IN THE UPPER MOST POSITION, THE 50" ROTARY MUST BE STOWED IN THE LOWER POSITION AND THE 60" ROTARY MUST BE STOWED IN THE LOWER POSITION ON THE STOP (06310017)

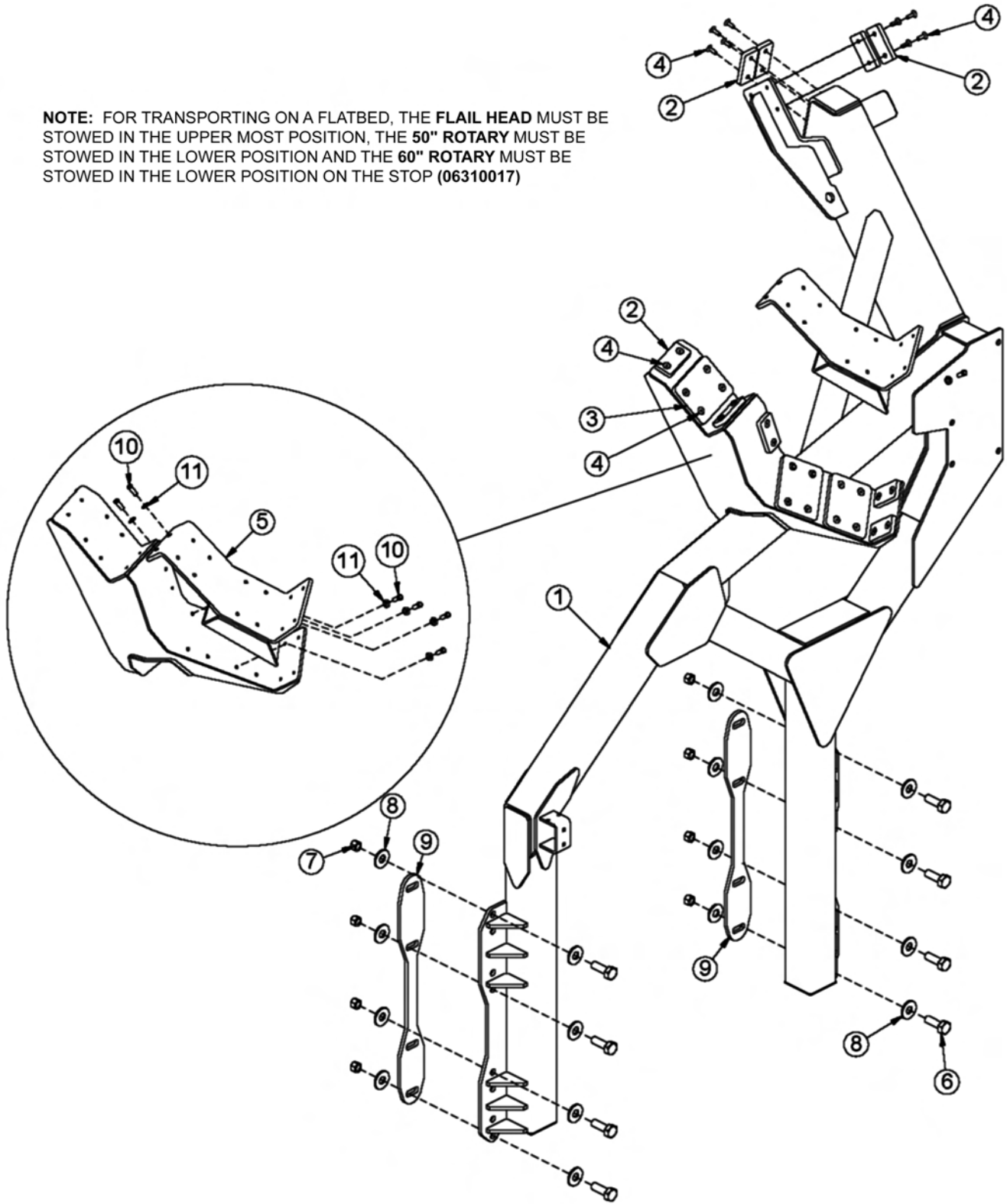

BOOMREST - BENGAL BRUTE

Continued...

ITEM	PART NO.	QTY.	DESCRIPTION
3	2853225;	3	DQQO TGUV.NTU
4	2874229;	:	UVTIR.TGUV.UGE.3
""4c	""2874229;	4	UVTIR.TGUV.UGE.3", HNCN'O QY GT
""4d	""2874229;	5	UVTIR.TGUV.UGE.3", 72\$TVT['O QY GT
""4e	""2874229;	4	UVTIR.TGUV.UGE.3", 82\$TVT['O QY GT
5	2874229;	5	UVTIR.TGUV.UGE.4
""5c	""2874229;	3	UVTIR.TGUV.UGE.4", HNCN'O QY GT
""5d	""2874229;	4	UVTIR.TGUV.UGE.4", 72\$TVT['O QY GT
""5e	""2874229;	4	UVTIR.TGUV.UGE.4", 82\$TVT['O QY GT
6	4: 956	52	ECRUETGY .HNVUMVJ F .5: \$Z'3\$.PE
""6c	""4: 956	:	ECRUETGY .HNVUMVJ F .5: \$Z'3\$.PE", HNCN'O QY GT
""6d	""4: 956	36	ECRUETGY .HNVUMVJ F .5: \$Z'3\$.PE", 72\$TVT['O QY GT
""6e	""4: 956	36	ECRUETGY .HNVUMVJ F .5: \$Z'3\$.PE", 82\$TVT['O QY GT
7	28532239	3	UVQR.VTD82.TU', 82\$TVT['O QY GT"QPN[
8	439: 4	:	ECRUETGY .7: \$Z'3/516\$.PE
9	43999	:	P[NQEMP WW.7: \$.PE
:	55986	38	HNCVY CUJ GT.7: \$.UCG
;	////	/	CZNG'DTCEG', TGHGT"VQ"VTCEVQT'O QWP V'MK
32	43852	8	ECRUETGY .5: \$Z'3\$.PE
33	43; : :	8	NQEMY CUJ GT.5: \$

COMMON LRS

BOOMREST - PANTHER

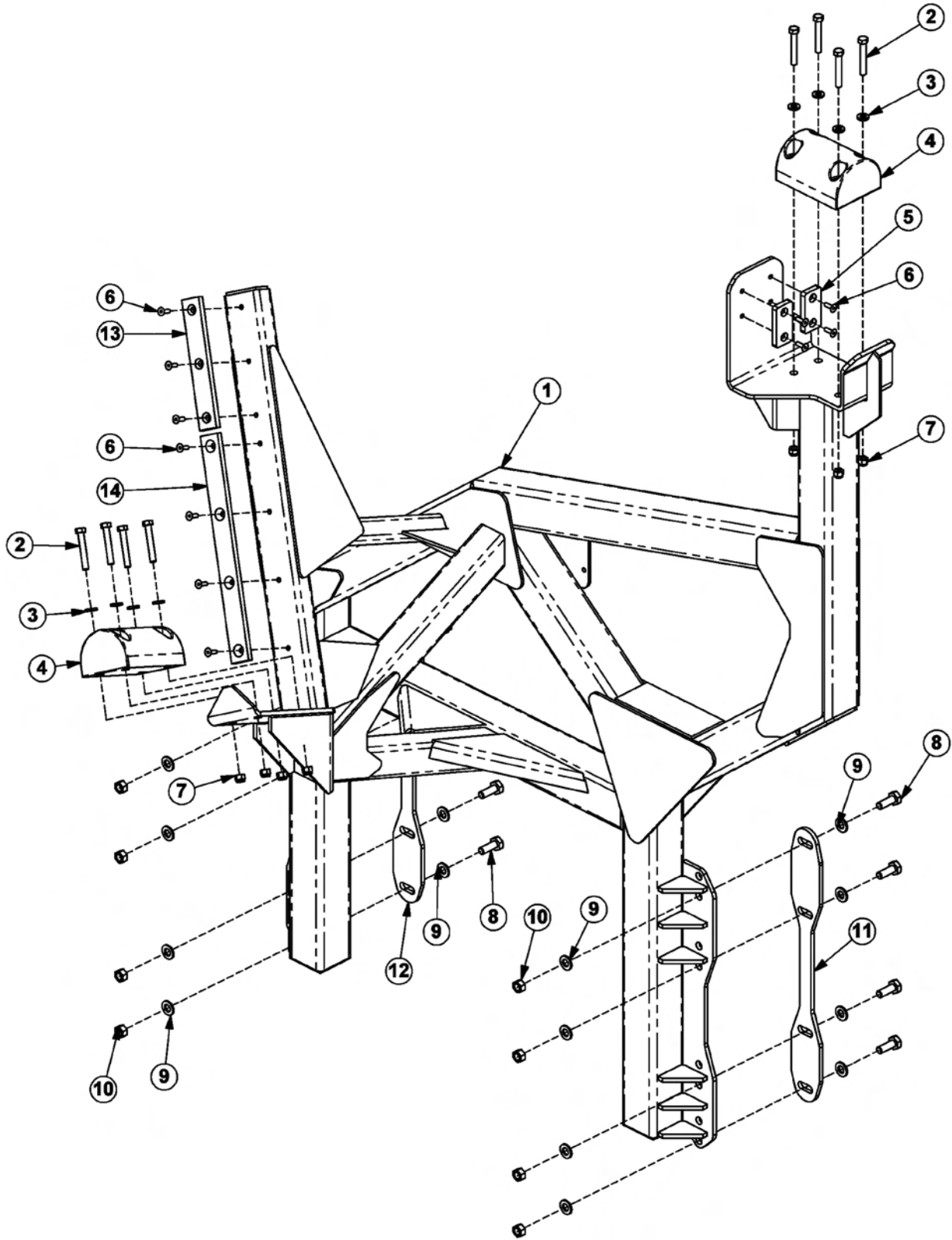

BOOMREST - PANTHER

Continued...

ITEM	PART NO.	QTY.	DESCRIPTION
3	285322: 8	3	DQQTGUV.RCP VJ GT.NTU
4	4395:	:	ECRUETGY .34\$Z'5/316\$.PE
5	44226	:	HNCVY CUJ GT.34\$.PCTTQY
6	28742658	4	DWORGT.TPF
7	2874229:	4	UVT R .TGUV
8	4: 956	33	ECRUETGY .51 \$Z'3\$.UMV'J F.PE
9	43949	:	P[NQEMP WW.34\$.PE
:	439: 4	:	ECRUETGY .71 \$Z'3/516\$.PE
;	55986	38	HNCVY CUJ GT.71 \$.UCG
32	43999	:	P[NQEMP WW.71 \$.PE
33	/////	/	CZNG'DTCEG.TK J V", TGHGT"VQ"VTCEVQT"O QWP V"MKV
34	/////	/	CZNG'DTCEG.NGHV", TGHGT"VQ"VTCEVQT"O QWP V"MKV
35	548: 8	3	Y GCTRCF .NQPI
36	54893	3	I W F G.RNCUV E

LEGAL REAR STOW RTRY PIVOT ASSY

MOTOR SERIAL TAG ON
SHIELD SIDE OF MOWER
(MOTOR OFFSET TOWARDS BACK)

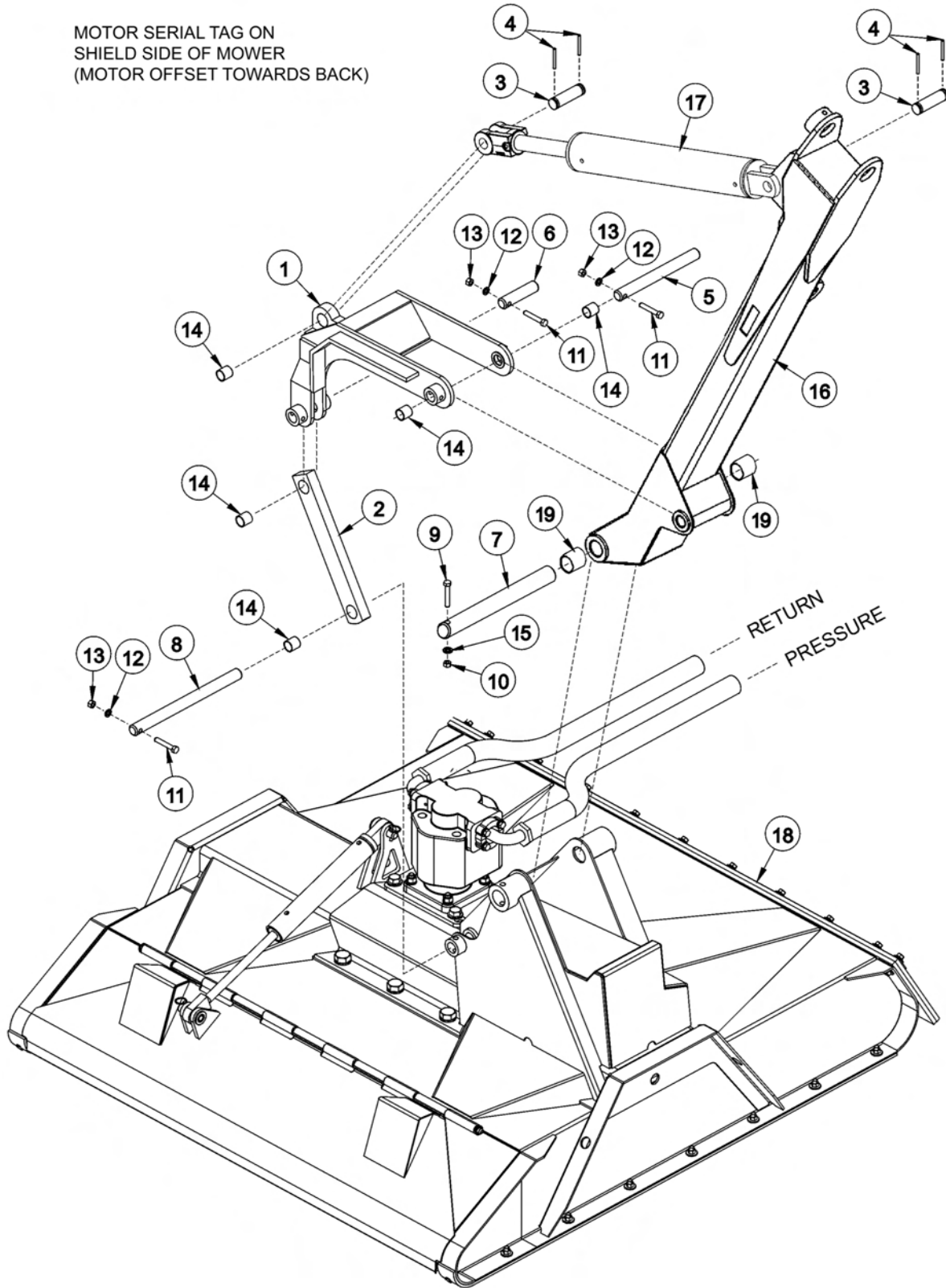

LEGAL REAR STOW RTRY PIVOT ASSY

Continued...

ITEM	PART NO.	QTY.	DESCRIPTION
3	28922238	3	RKQV'CUUGO DN[
4	28922237	3	RKQV'CTO 'CUUGO DN[
5	28642236	4	RK . 'ENGXU
6	VD3245	6	TQNNR
7	2864223;	3	RK
8	28642242	3	RK
9	28642238	3	RK
:	28642243	3	RK
;	438; :	3	ECRUETGY "9B8ö"Z"4/5 16ö."PE
32	43897	3	J GZ'P WW.'9B8ö."PE
33	43857	5	ECRUETGY "51 ö"Z"4"3 16ö
34	43; ; :	5	NQEMY CU GT"51 ö
35	43847	5	J GZ'P WW"51 ö
36	28742298	7	DGCTI . '3F"Z"3
37	43; ; ;	3	NQEMY CU GT"9B8ö
38	/////	/	UGEQPFCT['DQQO ", TGHGT"VQ'DQQO 'CTO 'CUU[
39	/////	/	E[NFGT", TGHGT"VQ'DQQO 'CTO 'CUU[
3:	/////	/	TQVCT['O QY GT"J GCF ", TGHGT"VQ" TQVCT['FGEM
3;	28742633	4	DGCTI . '302F"Z"402

LEGAL REAR STOW FLAIL PIVOT ASSY

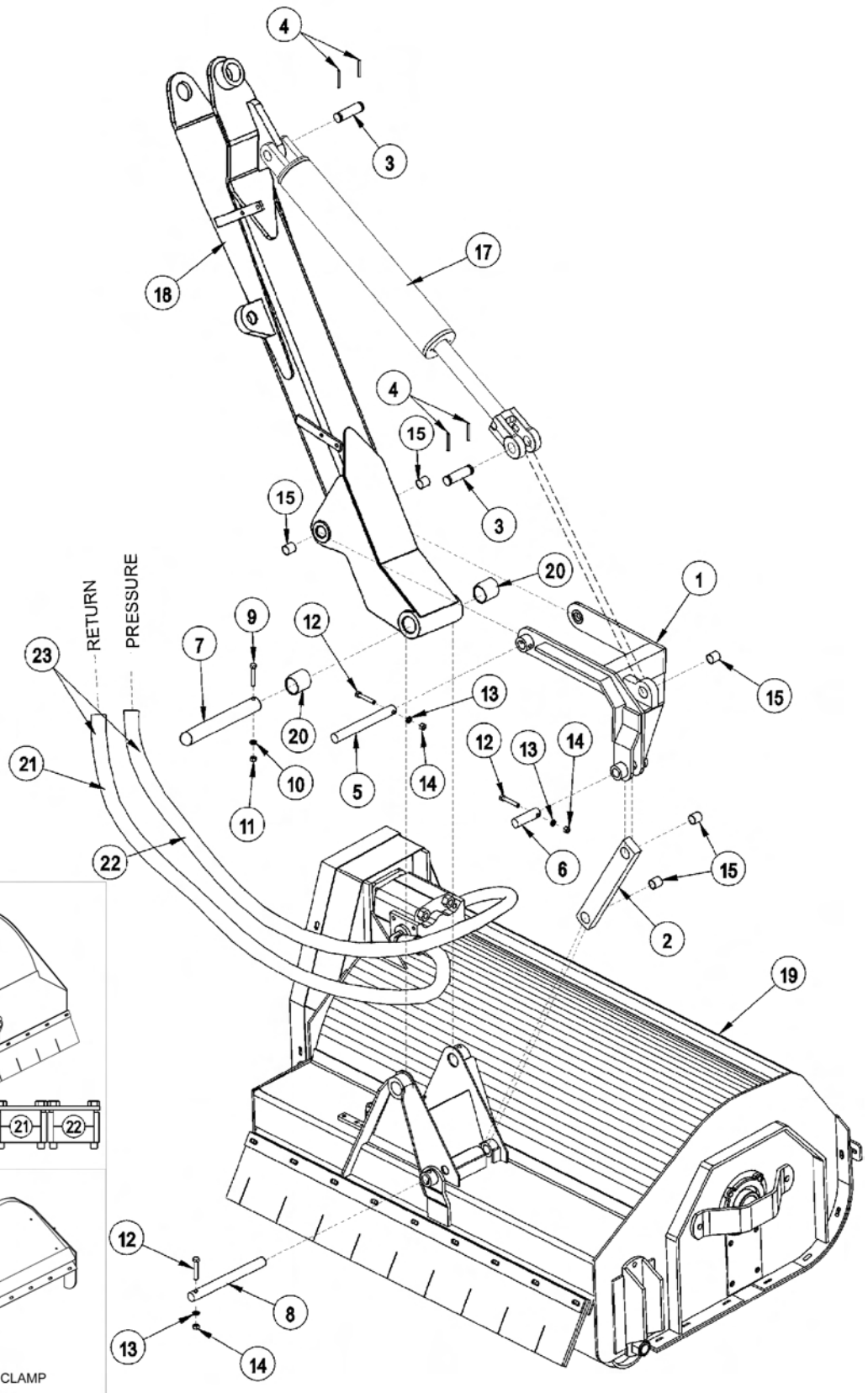

MOTOR SERIAL TAG
ON TOP

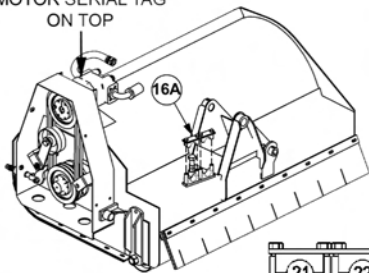

TBF50 HOSE CLAMP

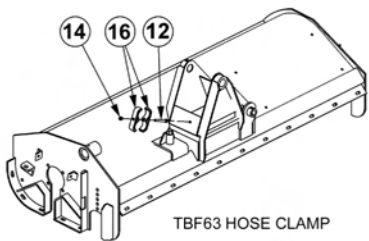

TBF63 HOSE CLAMP

LEGAL REAR STOW FLAIL PIVOT ASSY

Continued...

ITEM	PART NO.	QTY.	DESCRIPTION
3	2892224;	3	RKQV'CUUGO DN[
4	28922237	3	RKQV'CTO 'CUUGO DN[
5	28642236	4	RK'ENGXKU
6	VD3245	6	TQNNRKP
7	2864223;	3	RKP
8	28642242	3	RKP
9	2864223:	3	RKP
:	28642243	3	RKP
;	438: :	3	ECRUETGY "9B8ø"Z"5"3 16ø
32	43: ; :	3	NQEMY CUJ GT"9B8ø
33	43897	3	J GZ'P WW"9B8ø
34	43857	4	ECRUETGY "5: ø"Z"4"3 16ø
35	43: ; :	4	NQEMY CUJ GT"5: ø
36	43847	4	J GZ'P WW"5: ø
37	28742298	7	DGCTRP I . "3F"Z"3
38	VD5253	3	F QWDNG'J QUG'ENCOR" *WUGF 'QP "VJ G'85ø"HNCKN+
38C	53945	3	ENCOR'MK V."VDH"72" *WUGF 'QP "VJ G'72ø"HNCKN+
39	/////	/	E[NRFGT", TGHGT"VQ'DQOQO 'CTO 'CUJ
3:	/////	/	UGEQPFCT['DQOQO ", TGHGT"VQ'DQOQO 'CTO 'CUJ
3:	/////	/	HNCKN"O QY GT"J GCF ", TGHGT"VQ'HNCKN'EWWVGT"CUJ
42	28742633	4	DGCTRP I . "3Ø2K"Z"4Ø2
43	2872237:	3	J QUG."3ø"Z"367ø" *WUGF 'QP "VJ G'72ø"HNCKN+
44	2872237;	3	J QUG."3ø"Z"37: ø" *WUGF 'QP "VJ G'72ø"HNCKN+
45	2872237;	4	J QUG."3ø"Z"37: ø" *WUGF 'QP "VJ G'85ø"HNCKN+

50IN ROTARY MOWER ASSEMBLY

LINK TO THE SHIELD (OPTIONAL)

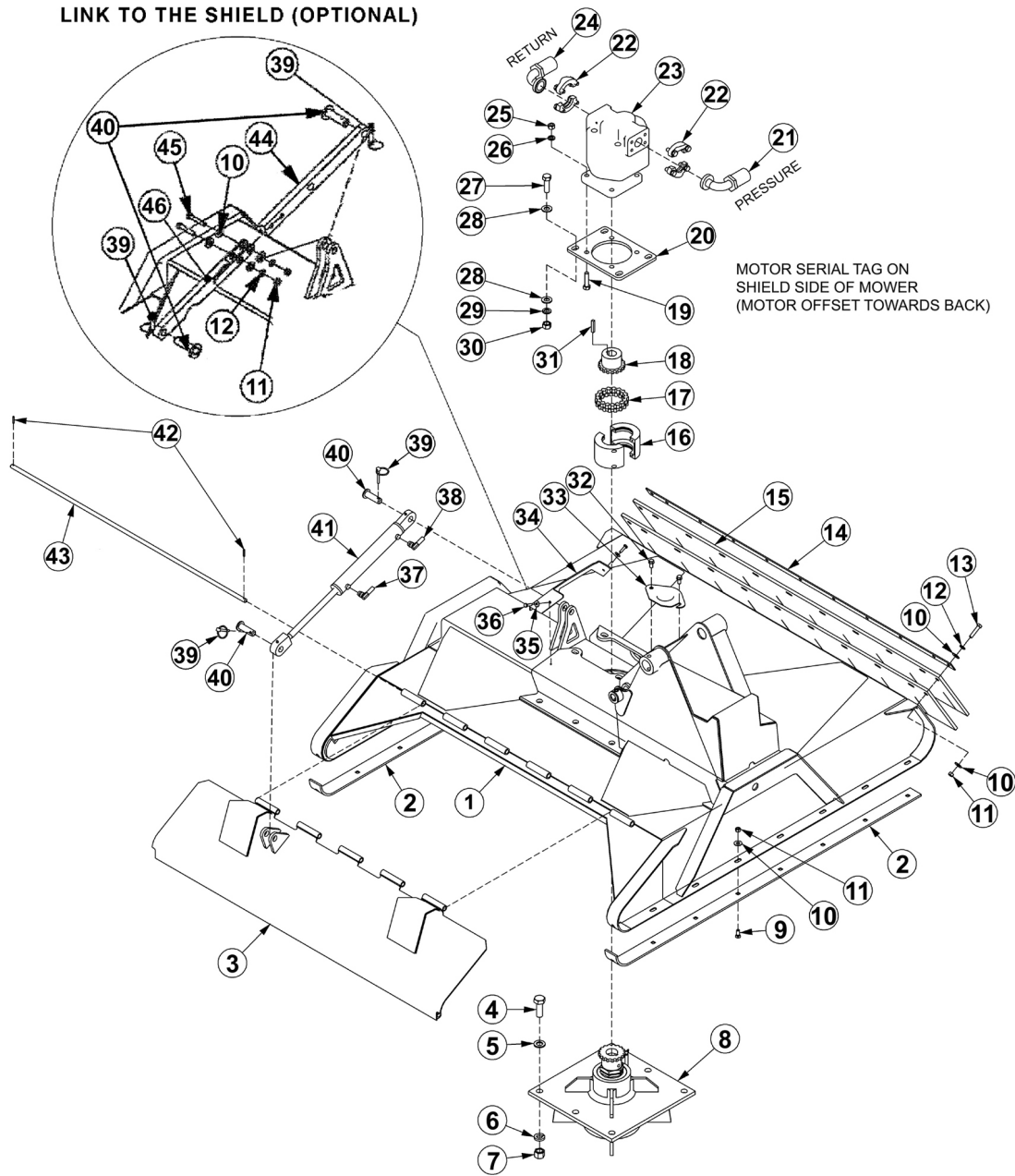

ITEM	PART NO.	QTY.	DESCRIPTION
1	33780	1	DECK,WLDMNT,50" RTRY
2	33777	2	SKID SHOE,50" RTRY
3	33754	1	SHIELD,50"RTRY
4	33879	6	CAPSCREW, 3/4 X 2 1/4,NF GR 8
5	33880	6	FLATWASHER,3/4",GR 8,SAE
6	21993	6	LOCKWASHER,3/4",GR 8
7	6T2413	6	HEX NUT,3/4,NF,GR 8
8	6T1024H5	1	SPINDLE ASSY,CPLT,HD,5/8 HOLES

COMMON LRS

50IN ROTARY MOWER ASSEMBLY

Continued...

ITEM	PART NO.	QTY.	DESCRIPTION
9	6T2270	16	PLOW BOLT,3/8" X 1" NC
10	22016	33	FLATWASHER,3/8"
11	21625	20	HEX NUT,3/8",NC
12	21988	11	LOCKWASHER, 3/8"
13	21633	11	CAPSCREW, 3/8 X 1 3/4,NC
14	33774	1	FLAP RETAINER,50" RTRY
15	33775	2	FLAP,50" RTRY
16	6T1033	1	COUPLER COVER
17	6T1029	1	COUPLER CHAIN
18	21223	1	SPROCKET
19	21733	4	CAPSCREW, 1/2 X 2,NC
20	33776	1	MOTOR MOUNT,PLATE,50" RTRY
21	24490	1	HOSE - PRESSURE
---	06500155	1	HOSE- PRESSURE (LRS ONLY)
22	TF4852	2	FLANGE KIT - #20
23	06504012	1	MOTOR
24	24489	1	HOSE - RETURN
---	06500154	1	HOSE-RETURN (LRS ONLY)
25	21725	4	HEX NUT, 1/2" NC
26	06533004	4	FLATWASHER, 1/2"
27	6T2290	4	CAPSCREW,5/8X2,NF GR 8
28	33764	8	FLATWASHER,5/8",GR 8,SAE
29	21992	4	LOCKWASHER, 5/8
30	6T2408	4	HEX NUT, 5/8, NF
31	TF1124	1	SQUARE KEY
32	33881	2	CAPSCREW,FLG, 3/8 X 3/4,NC
33	33779	1	PLATE,COVER,KNF HOLE
34	06410439	1	COVER
35	22014	2	FLATWASHER,1/4
36	21530	2	CAPSCREW,1/4 X 1,NC
37	34187	1	HOSE 1/4" X 75"
38	34186	1	HOSE 1/4" X 66"
39	RD1032	2	LYNCH PIN
40	33984	2	PIN,SHIELD,50"
41	33785	1	1-1/2" X 8", CYLINDER, WELDED
42	6T3017	2	ROLLPIN
43	33778	1	HINGE PIN,50" RTRY
44	33772	1	LINK, SHIELD 50" RTRY
45	21634	2	CAPSCREW, 3/8" X 2, NC
46	33773	1	LINK 2, SHIELD 50" RTRY

COMMON LRS

60IN ROTARY MOWER ASSEMBLY

LINK TO THE SHIELD (OPTIONAL)

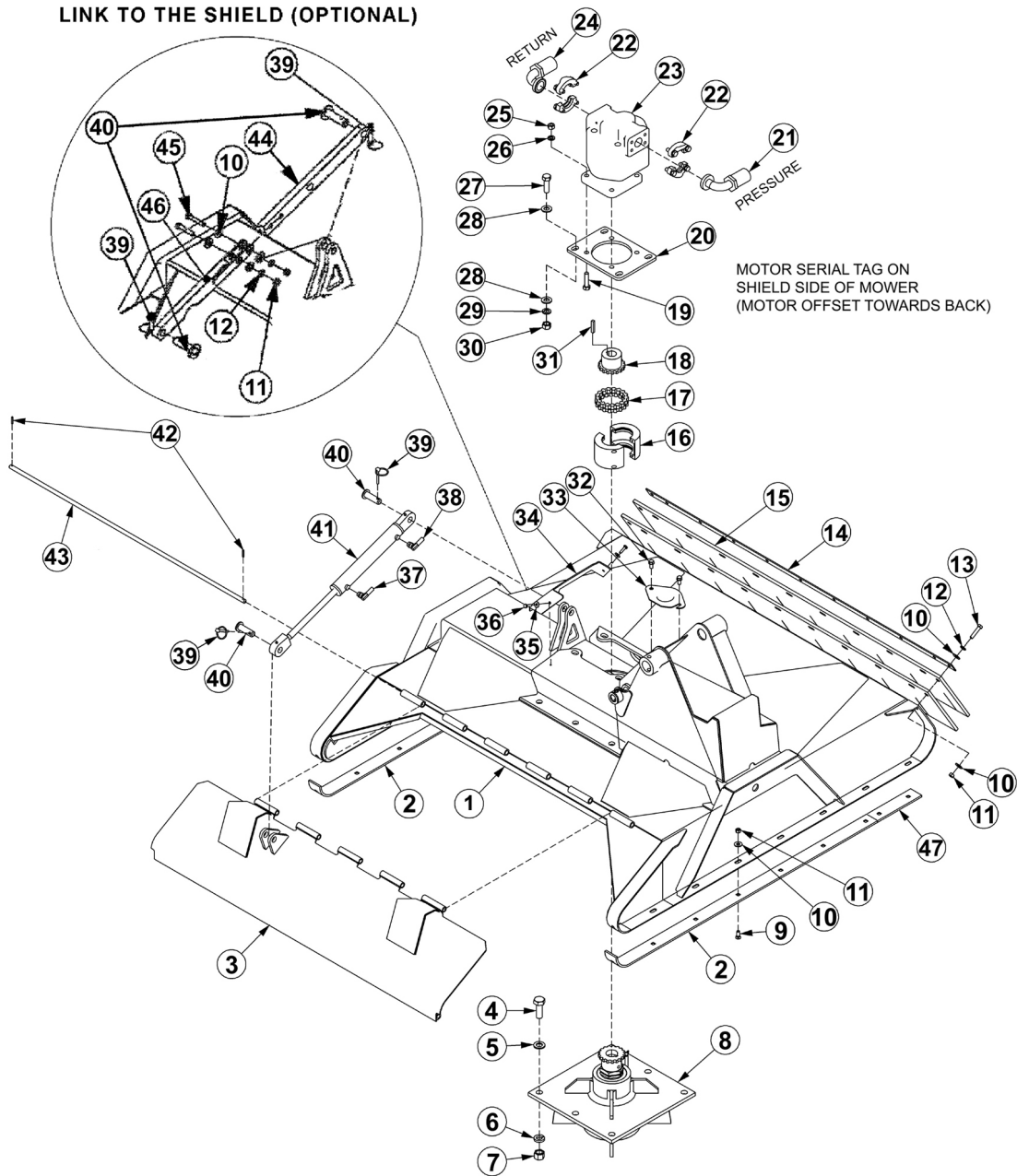

ITEM	PART NO.	QTY.	DESCRIPTION
1	06320159	1	DECK,WLDMNT,60" RTRY
2	33777	2	SKID SHOE,RTRY
3	06320162	1	SHIELD,60"RTRY
4	33879	6	CAPSCREW, 3/4 X 2 1/4,NF GR 8
5	33880	6	FLATWASHER,3/4",GR 8,SAE
6	21993	6	LOCKWASHER,3/4",GR 8
7	6T2413	6	HEX NUT,3/4,NF,GR 8
8	6T1024H5	1	SPINDLE ASSY,CPLT,HD,5/8 HOLES

COMMON LRS

60IN ROTARY MOWER ASSEMBLY

Continued...

ITEM	PART NO.	QTY.	DESCRIPTION
9	6T2270	16	PLOW BOLT,3/8" X 1" NC
10	22016	33	FLATWASHER,3/8"
11	21625	20	HEX NUT,3/8",NC
12	21988	11	LOCKWASHER, 3/8"
13	21633	11	CAPSCREW, 3/8 X 1 3/4,NC
14	6T0823	1	FLAP RETAINER,60" RTRY
15	06520238	2	FLAP,60" RTRY
16	6T1033	1	COUPLER COVER
17	6T1029	1	COUPLER CHAIN
18	21223	1	SPROCKET
19	21733	4	CAPSCREW, 1/2 X 2,NC
20	33776	1	MOTOR MOUNT,PLATE,RTRY
21	24490	1	HOSE - PRESSURE
---	06500155	1	HOSE-PRESSURE (LRS ONLY)
22	TF4852	2	FLANGE KIT - #20
23	6504011	1	MOTOR
24	24489	1	HOSE - RETURN
---	06500154	1	HOSE-RETURN (LRS ONLY)
25	21725	4	HEX NUT, 1/2" NC
26	06533004	4	FLATWASHER, 1/2"
27	6T2290	4	CAPSCREW,5/8X2,NF GR 8
28	33764	8	FLATWASHER,5/8",GR 8,SAE
29	21992	4	LOCKWASHER, 5/8
30	6T2408	4	HEX NUT, 5/8, NF
31	TF1124	1	SQUARE KEY
32	33881	2	CAPSCREW,FLG, 3/8 X 3/4,NC
33	33779	1	PLATE,COVER,KNF HOLE
34	06410439	1	COVER
35	22014	2	FLATWASHER,1/4
36	21530	2	CAPSCREW,1/4 X 1,NC
37	34187	1	HOSE 1/4" X 75"
38	34186	1	HOSE 1/4" X 66"
39	RD1032	2	LYNCH PIN
40	33984	2	PIN,SHIELD
41	33785	1	1-1/2" X 8", CYLINDER, WELDED
42	6T3017	2	ROLLPIN
43	06420139	1	HINGE PIN,60" RTRY
44	33772	1	LINK, SHIELD,RTRY
45	21634	2	CAPSCREW, 3/8" X 2, NC
46	33773	1	LINK 2, SHIELD,RTRY
47	06401245	2	SKID SHOE,TRB60

COMMON LRS

50IN ROTARY KNIVES AND DISH

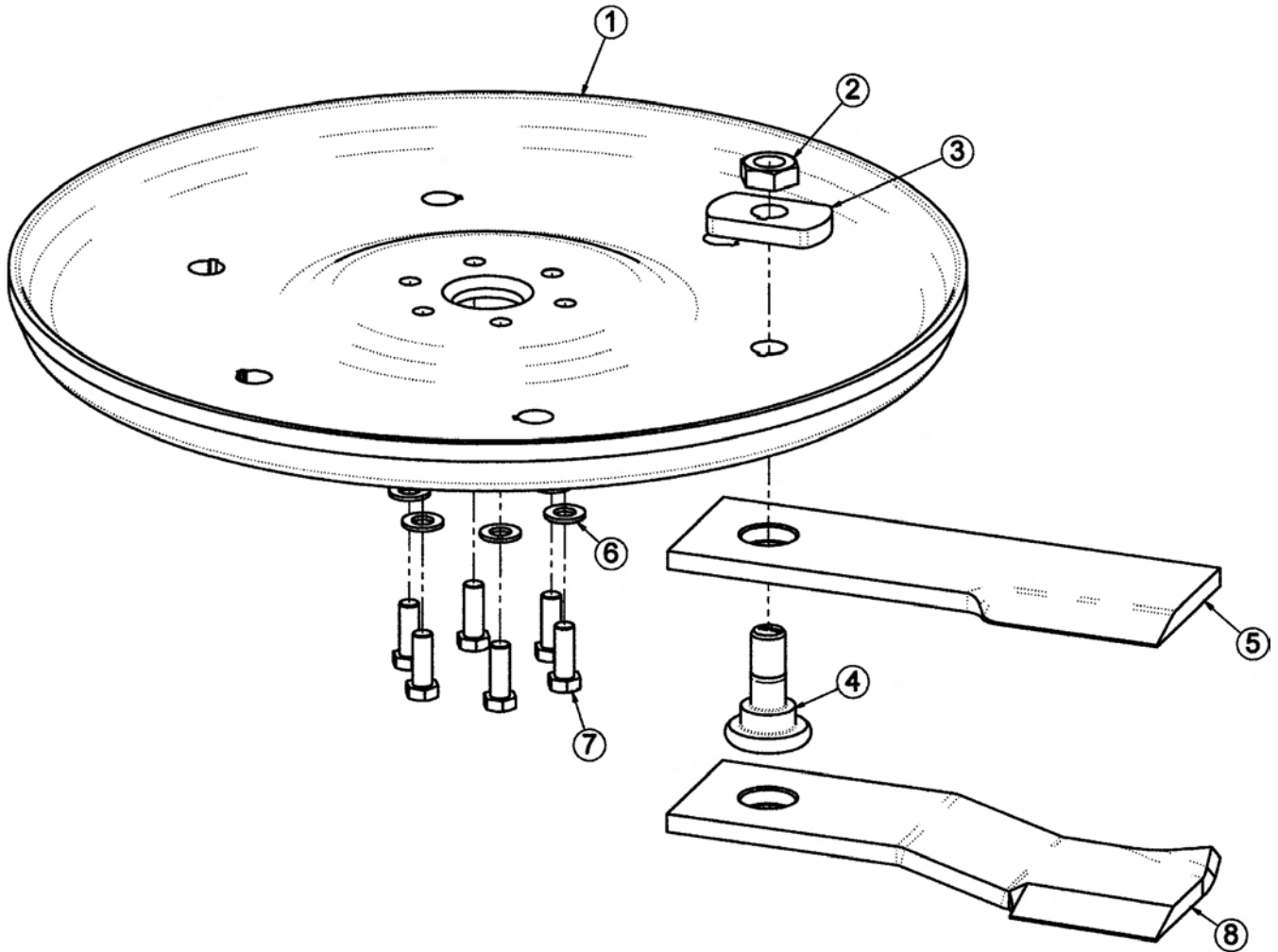

ITEM	PART NO.	QTY.	DESCRIPTION
//////	289222; ;	/	MKV.VTD72.F KUMY IDQNV'MKV"MP ENWF GU'KVG+ U'3.5"('9+
3	28992225	3	DNCF G'O QWP VR I 'F KUM
4	8V3245T	4	P [NQEMJ GZ 'P W'"3'3E ö
5	56: 9:	4	URCEGT
6	2875: 222	4	MP KEG'O QWP VR I 'DQNV
7	28743223	4	UVCP F CTF 'MP KEG
8	55986	8	HNCVY CUI GT
9	8V447;	8	ECRUETGY
//////	28992234	/	DQNV'MKV"MP ENWF GU'KVG+ U'8.'9('NQEVK/G+
:	28743224	4	I TCU'MP KEG"QRVIQP CN+
//////	8V3: 47	/	NQEVK/G/"WUGF 'QP 'CNNF KUM'O QWP VR I 'DQNVU

COMMON LRS

50IN ROTARY BLADE BAR AND KNIVES

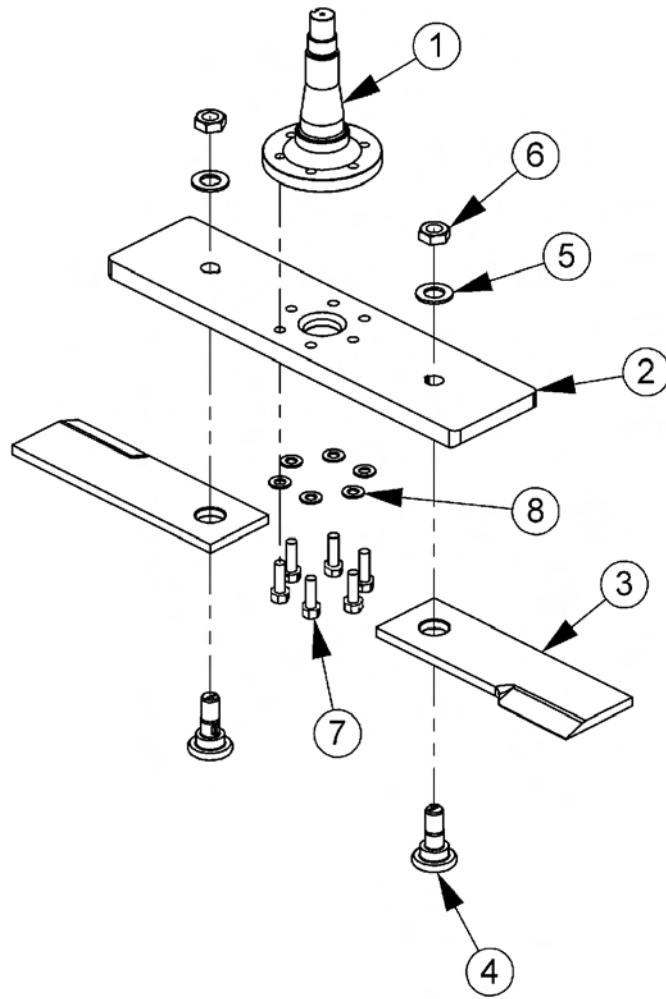

ITEM	PART NO.	QTY.	DESCRIPTION
3	RV323: J 7	3	URP FNG.7E J QNGUJ F.Y QIVCDU
4	286225: :	3	DCT.DNCF G.VTD
5	28743223	4	MP H'G' VTD72.7E
6	2875: 222	4	MP H'G' O VI 'DQNV.7E 'UJ QWNFGT
7	28755224	4	HNCVY CUJ GT.3'3E .I T':
8	8V3245T	4	MP H'G' O VI 'P WV.3'3E .PHI T:
9	8V447;	8	ECRUETGY .7E Z3/516.PHI T:
:	55986	8	HNCVY CUJ GT.7E .I T': .UCG

COMMON LRS

60IN ROTARY KNIVES AND DISH

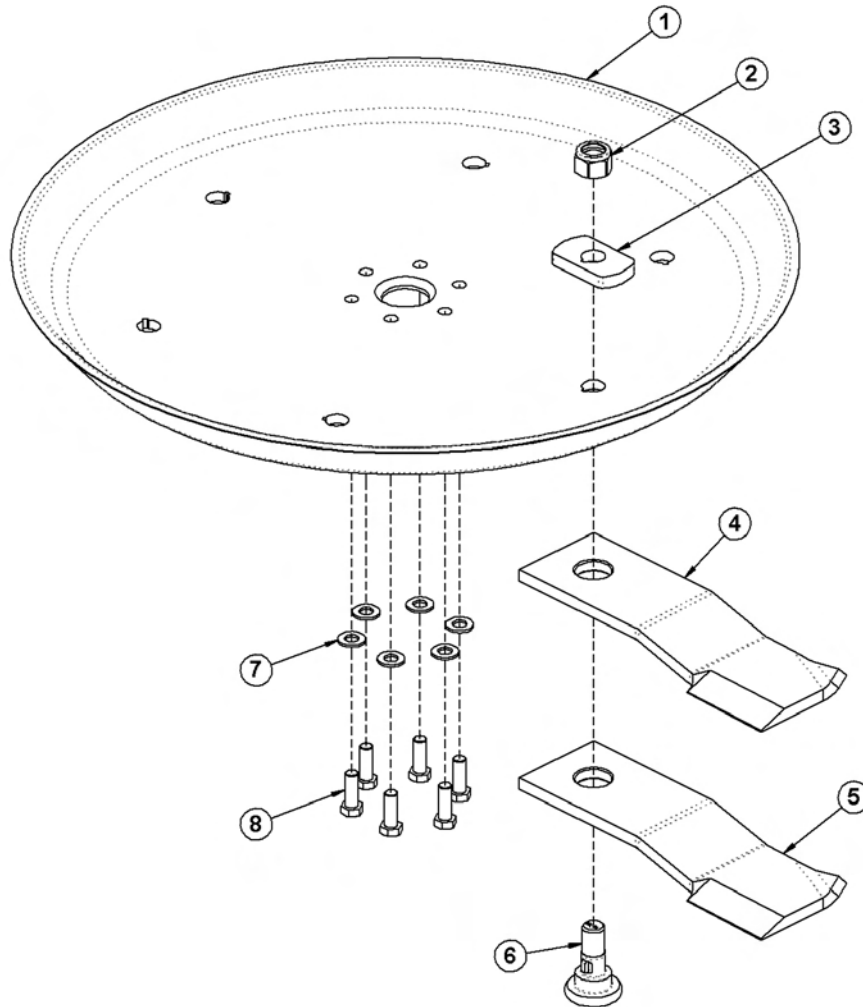

ITEM	PART NO.	QTY.	DESCRIPTION
3	56: 98	3	DNCFG'QWP VPI 'FKU .82\$
4	8V3245T	4	P[NQEMPWV.3/31 \$.PH
5	56: 9:	4	URCEGT
6	568: 6	4	UVCPTCTF'I TCUUMP KIG
7	568: 7	4	J K J 'UWEVQP'I TCUUMP KIG*QRVQP CN+
8	566: 9	4	MP KIG'QWP VPI 'DQNV
9	47492	8	HNCVY CUI GT.71 \$I T: .WUU
:	8V447;	8	ECRUETGY .71 \$Z'3/516\$.PHI T:
///	8V3: 47	3	NQEMVK/G*WUGF 'QP 'K/GO ': +
////	49389	/	DQNV'MK/'P ENWF GU'K/GO U9'(' ': +
///	55: ; 5	/	MP KIG'MK/'P ENWF GU'K/GO U'4.'6'(' '8+

COMMON LRS

60IN ROTARY BLADE BAR AND KNIVES

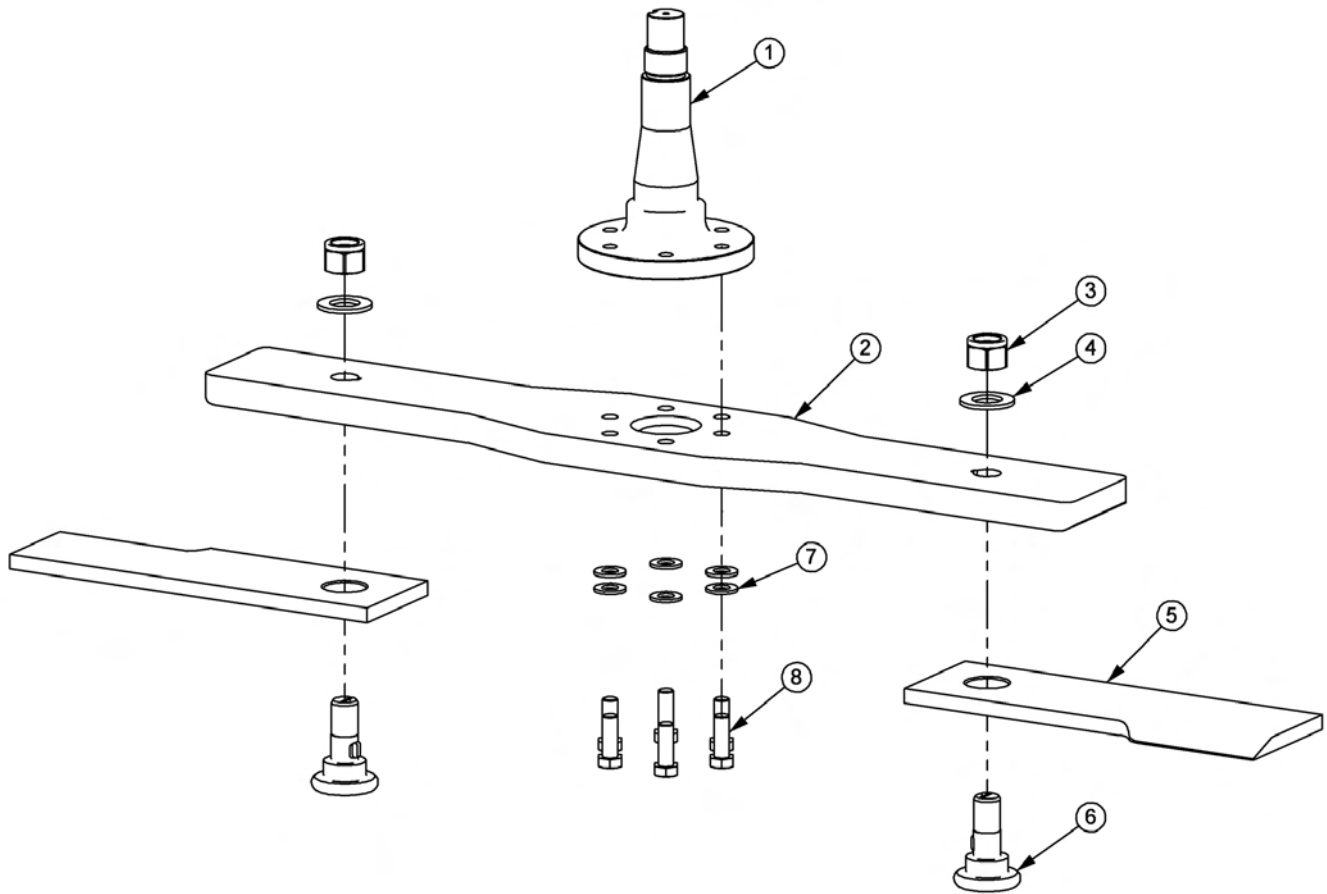

ITEM	PART NO.	QTY.	DESCRIPTION
3	RV323; J 7	3	URRPFNG
4	286228; 2	3	DCT.DNCFGTVT[82
5	8V3245T	4	MPKHOVI 'PWW.3/3E.P[NQEMPH
6	28755224	4	HNCVY CUJ GT.3/3E.I.T:
7	28743223	4	MPKHOVI 'DQNV.7E 'UJ QWNFGT
8	2875; 222	4	MPKHOVI 'DQNV.7E 'UJ QWNFGT
9	55986	8	HNCVY CUJ GT.7E.I.T'.UCG
:	8V447;	8	ECRUETGY .7E 'Z'3/516.PHI T:

COMMON LRS

50IN FLAIL DRIVE ASSEMBLY

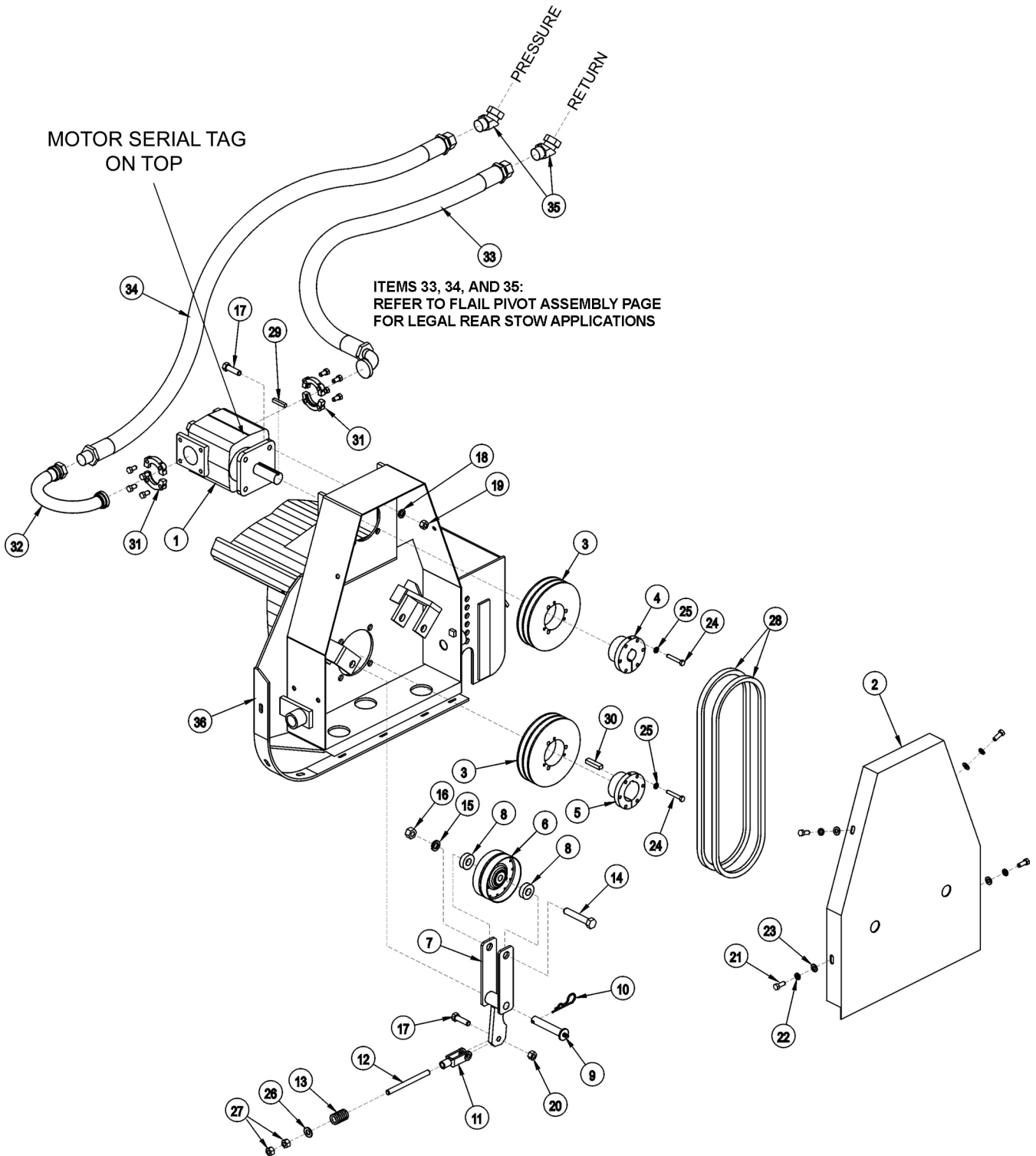

50IN FLAIL DRIVE ASSEMBLY

Continued...

ITEM	PART NO.	QTY.	DESCRIPTION
1	06504013	1	MOTOR (M350-1 3/4" GEAR)
2	TF3006	1	BELT GUARD
3	TF3043	2	SHEAVE
4	TF3013	1	BUSHING
5	TF3011	1	BUSHING
6	TF3034	1	IDLER PULLEY
7	TF3205	1	IDLER ARM
8	TF3206	2	IDLER PULLEY SPACER
9	TF3605	1	IDLER ARM PIN WITH ZERK
10	6T3004	1	R - CLIP
11	PT3611A	1	CLEVIS
12	32481	1	THREADED ROD
13	TF3620	1	COMPRESSION SPRING
14	21789	1	CAPSCREW 5/8" X 3 1/2"
15	21992	1	LOCKWASHER 5/8"
16	21775	1	HEX NUT 5/8"
17	21732	5	CAPSCREW 1/2" X 1 3/4"
18	21990	4	LOCKWASHER 1/2"
19	21725	4	HEX NUT 1/2"
20	6T2418	1	LOCK NUT 1/2"
21	21630	4	CAPSCREW 3/8" X 1"
22	21988	4	LOCKWASHER 3/8"
23	22016	4	FLATWASHER 3/8"
24	21584	6	CAPSCREW 5/16" X 2"
25	21987	6	LOCKWASHER 5/16"
26	27938	1	FLATWASHER 1/2"
27	21700	2	HEX NUT 1/2" NF
28	TF3021	2	BELT
29	TF1125	1	SQUARE KEY
30	TF1025	1	SQUARE KEY MOTOR
31	TF4852	2	FLANGE KIT
32	34227	1	PREFORMED TUBE
33	31218	1	HOSE - RETURN
34	34331	1	HOSE - PRESSURE
35	24724	2	SWIVEL FITTING
36	-----	-	CUTTER HEAD *REFER TO CUTTER HEAD ASSY

COMMON LRS

50IN FLAIL MOWER ASSEMBLY

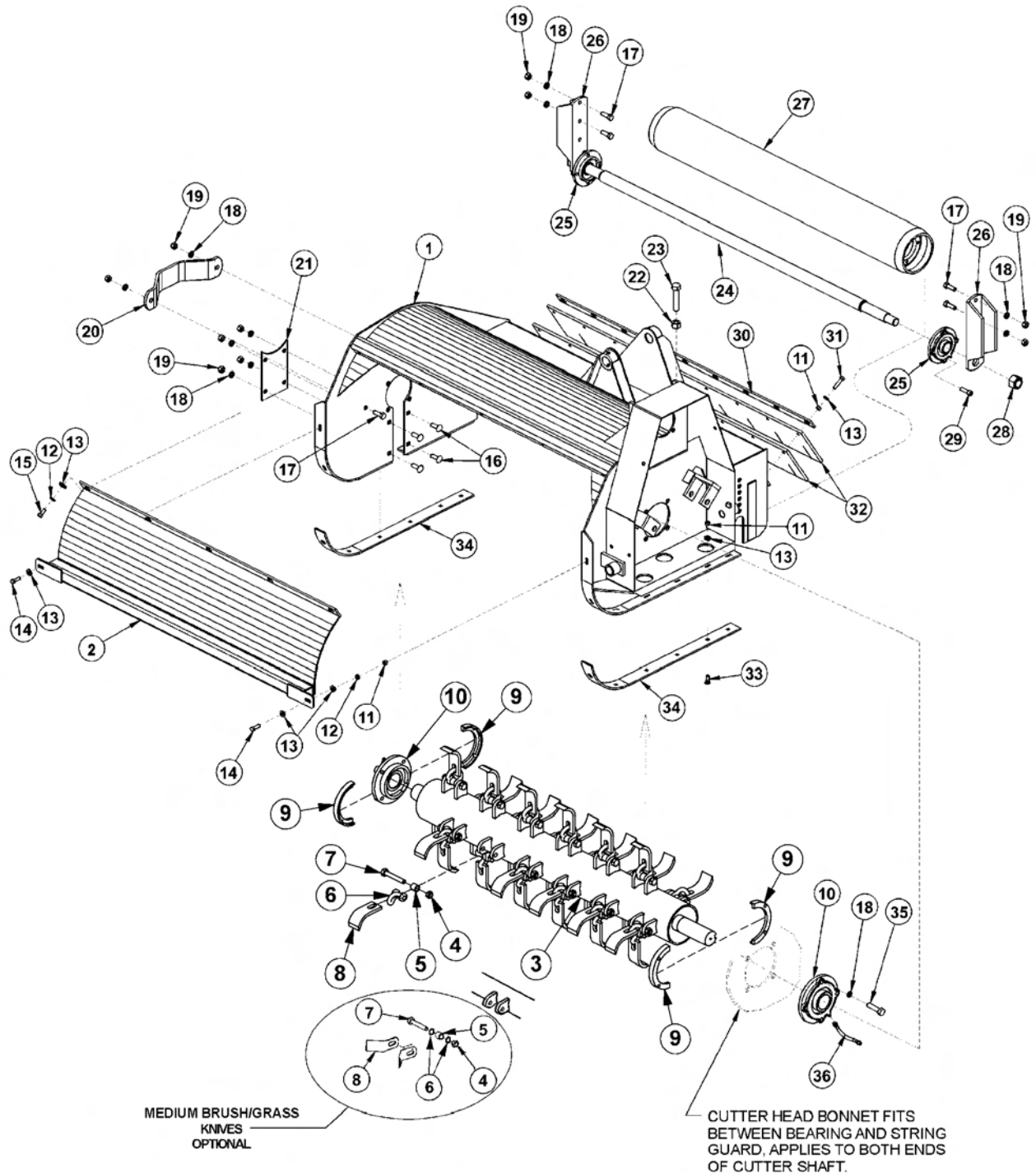

ITEM	PART NO.	QTY.	DESCRIPTION
///	569: 9	3	HCKNDQOQ.72.DTWUJ .ERNVCUUJ *NK J V'DTWUJ II TCUU+
	28964355	3	HCKNDQOQ.72.OF'I TCUEARNVCUUJ *OGFKWO'DTWUJ II TCUU+
3	VH5225H	3	EWVGT'J GCF'DQPPGV
4	VH5226	3	HI'QP V'UJ KGNF

COMMON LRS

50IN FLAIL MOWER ASSEMBLY

Continued...

ITEM	PART NO.	QTY.	DESCRIPTION
5	569: 5	3	VDH72"NK J VDTWUJ II TCUMPKGCUUJ +
////	28922337	3	VDH72"O GF KWO 'DTWUJ II TCUMPKGCUUJ +
6	8V463;	46	J GZ'P WW.; B8ö.P.E.UVQXGT
7	63947023J V	46	DWUJ RPI .3SQF"Z"7E SF
8	569: 4	46	ENGXU"NK J VDTWUJ II TCUMPKGU+
////	28652344	6:	URCEGT"O GF KWO 'DTWUJ II TCUMPKGU+
9	569: 8	46	ECRUETGY .; B8ö"Z"5/34ö.PE
:	569: 2	46	MPKG"NK J VDTWUJ II TCUEWVRI +
////	28743229	6:	MPKG"O GF KWO 'DTWUJ II TCUEWVRI +
;	53426	4	UVTRPI 'I WCTF "UGV""4"RIGEGURGT"UGV+
32	VH23:	4	HNCPI G'DGCTRI .4/5B8ö
33	43847	45	J GZ'P WW.5E ö.PE
34	43; ; :	9	NQEMY CUJ GT.5E ö
35	44238	52	HNCVY CUJ GT.5E ö
36	43853	4	ECRUETGY .5E ö"Z"3/34ö.PE
37	43852	7	ECRUETGY .5E ö"Z"3ö.PE
38	8V9253F	6	RNQY "DQNV.34ö"Z"3/34ö.PE
39	43953	8	ECRUETGY .34ö"Z"3/34ö.PE
3:	43; ; 2	3:	NQEMY CUJ GT.34ö
3;	43947	32	J GZ'P WW.34ö.PE
42	VH262	3	EWVGT"UI CHVI WCTF
43	VH5229C	3	EQXGT"RNCVG
44	43: 47	3	J GZ'P WW.7E ö.PE
45	43: 5:	3	ECRUETGY .516ö"Z"5/34ö.PE
46	VH5628	3	I TQWPF "TQNNGT"VKGTQF
47	VH244	4	HNCPI G'DGCTRI .3/5E ö
48	VH5629	4	I TQWPF "TQNNGT"CF LWUVO GP VDTCEMGV
49	VH5627	3	I TQWPF "TQNNGT
4:	8V3245T	4	P[NQEMP WW.3/3E ö.PH
4;	8V4552	:	ECRUETGY .9B8ö"Z"3/34ö.UQEMGV"J GCF
52	VD322:	3	HNCRTGVCRI RPI 'DCT
53	43855	;	ECRUETGY .5E ö"Z"3/516ö.PE
54	VD3228C	4	F GHNGEVQT"HNCR
55	8V4492	34	RNQY DQNV.5E ö"Z"3ö.PE
56	VH5223	4	UMF "UI QG
57	2875243:	:	ECRUETGY .34ö"Z"3/516ö.PE
58	VH254	3	HNCPI G'DGCTRI 'I TGCUGJ QUG

COMMON LRS

50IN FLAIL MOWER ASSY, PASS-THROUGH KNIVES

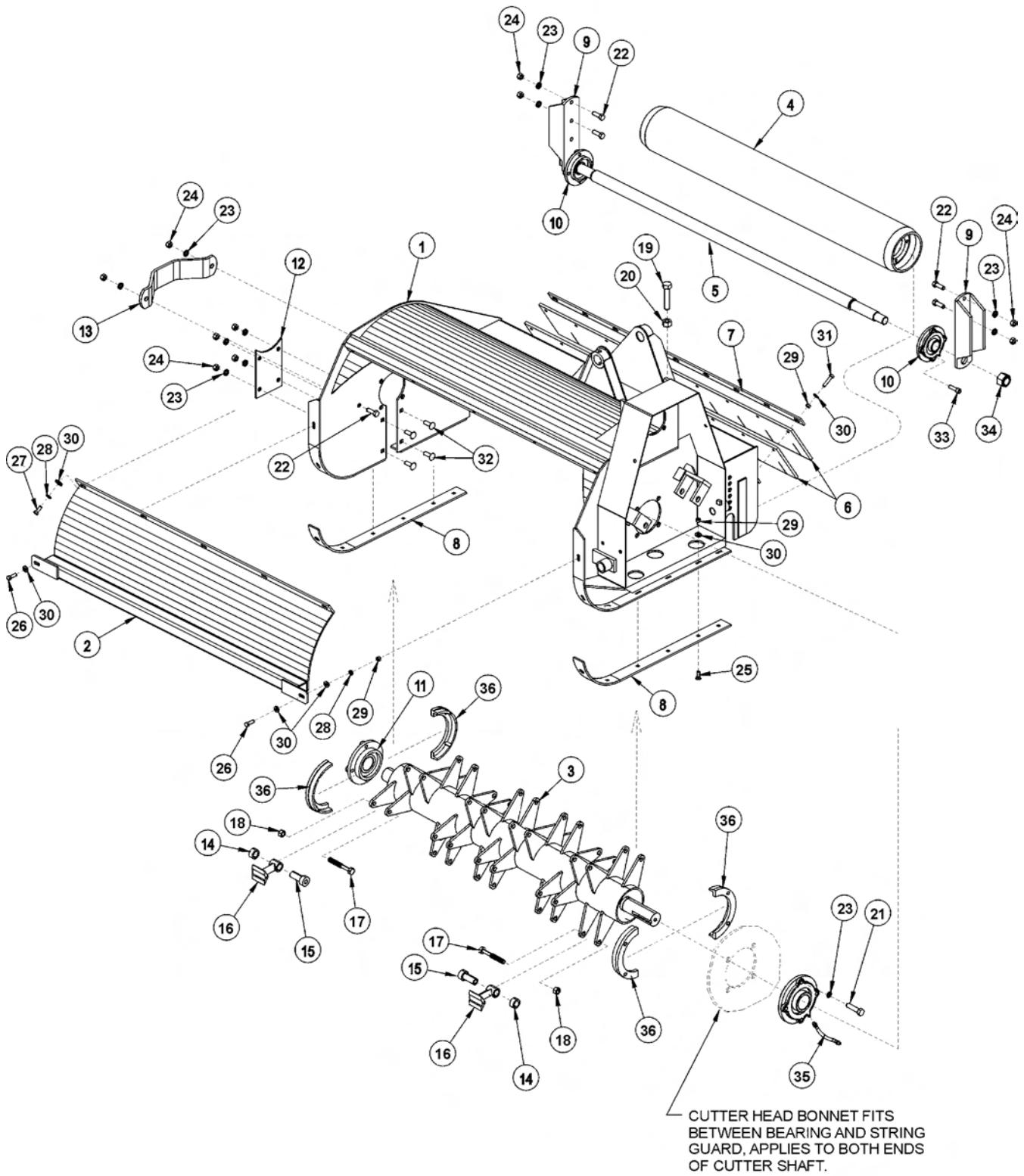

50IN FLAIL MOWER ASSY, PASS-THROUGH KNIVES

Continued...

ITEM	PART NO.	QTY.	DESCRIPTION
///	56394	3	HNCNKDQOQO.72.ERNV'CUUJ
3	VH5225H	3	EWVVG'T'J GCF'DQP P'GV
4	VH5226	3	H'QP V'UJ KGNF
5	55939	3	VDH72.EWVVG'T'UJ CHV.RCUU'VJ TWMP &GU
6	VH5627	3	I TQWPF'T'QNNGT
7	VH5628	3	I TQWPF'T'QNNGT'VKGTQF
8	VD3228C	4	F GHNGEVQT'HNCR
9	VD322:	3	HNCR'TGVC'R P'I 'DCT
:	VH5223	4	UMF'UJ QG
;	VH5629	4	I TQWPF'T'QNNGT'CF LWUVO GP V'DTCEMGV
32	VH244	4	HNCPI G'DGCT'R I .3/5 1/2
33	VH23:	4	HNCPI G'DGCT'R I .4/5 B86
34	VH5229C	3	EQXGT'RNCVG
35	VH262	3	EWVVG'T'UJ CHV'I WCTF
36	55: 7:	46	URCEGT.EQNNCT
37	55: 79	46	UJ QWNF'GT.DWUJ R'I
38	685: ; 03	46	MP H'G.HNCKN.HQTI GF
39	55: 76	46	ECRUETGY .71 \$Z'6/3 1/4\$.PE
3:	54896	46	J GZ'P WW.71 \$.PE
3:	43: 5:	3	ECRUETGY .5 1/6 \$Z'5/3 1/4\$.PE
42	43: 47	3	J GZ'P WW.71 1/2\$.PE
43	43954	:	ECRUETGY .3 1/4 \$Z'3/5 1/6\$.PE
44	43953	8	ECRUETGY .3 1/4 \$Z'3/3 1/4\$.PE
45	43: ; 2	3:	NQEMY CUJ GT.3 1/4
46	43947	32	J GZ'P WW.3 1/4\$.PE
47	8V4492	34	RNQY DQNV.51 1/2 \$Z'3 1/4\$.PE
48	43853	4	ECRUETGY .51 1/2 \$Z'3/3 1/6\$.PE
49	43852	7	ECRUETGY .51 1/2 \$Z'3 1/4\$.PE
4:	43: ; :	9	NQEMY CUJ GT.51 1/2
4:	43847	45	J GZ'P WW.51 1/2 \$.PE
52	44238	52	HNCVY CUJ GT.51 1/2
53	43855	;	ECRUETGY .51 1/2 \$Z'3/5 1/6\$.PE
54	8V9253F	6	RNQY 'DQNV.3 1/4 \$Z'3/3 1/4\$.PE
55	8V4552	:	ECRUETGY .9 B86 \$Z'3/3 1/4\$.PE.UEMV'J F
56	8V3245T	4	P[NQEMP WW.3/3 1/2 1/2\$.PH
57	VH254	3	HNCPI G'DGCT'R I 'I TGCUG'J QUG
58	53426	4	UVT'R I 'I WCTF 'UGV''RIGEGU'RGT'UGV+

COMMON LRS

63IN FLAIL DRIVE ASSEMBLY

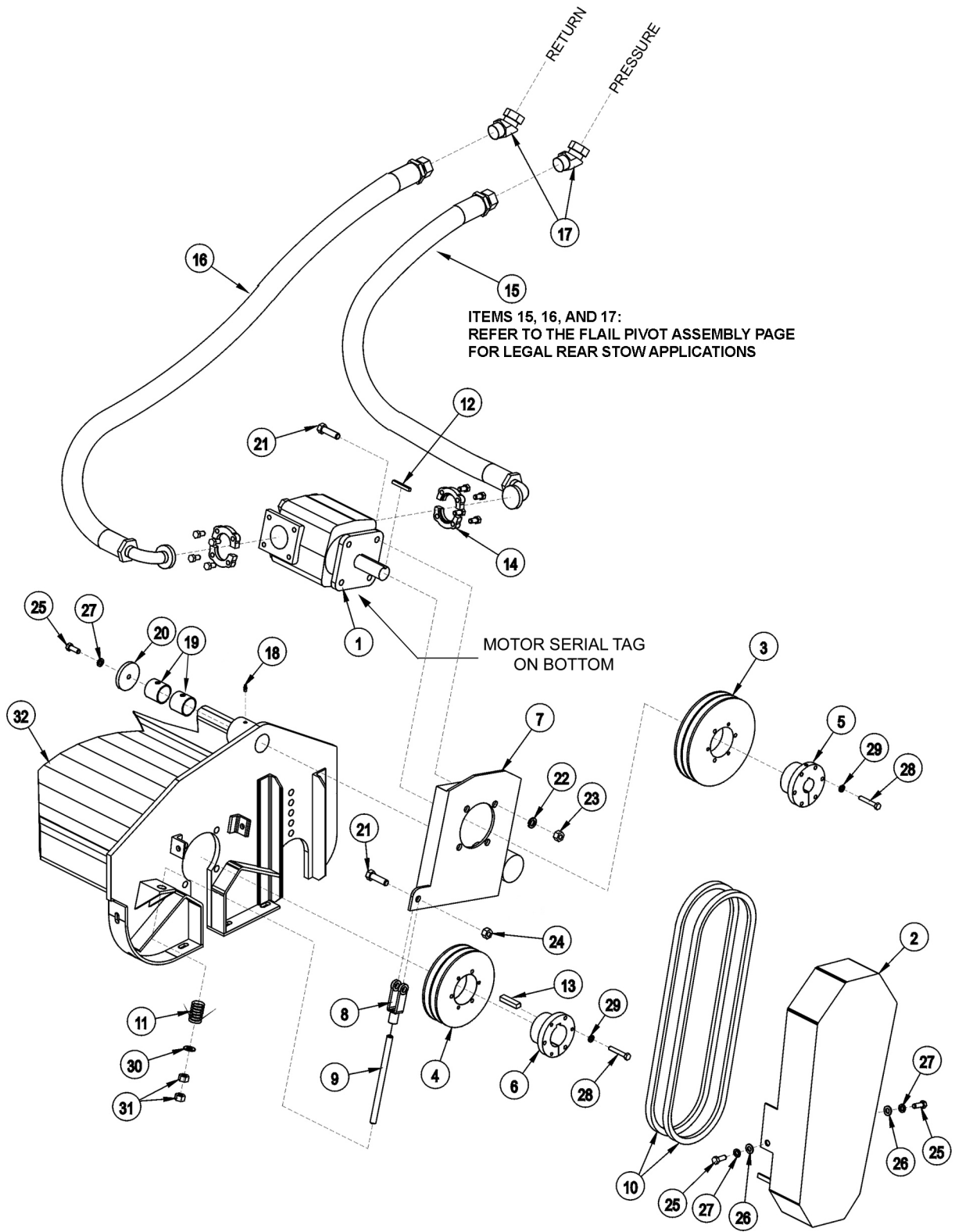

63IN FLAIL DRIVE ASSEMBLY

Continued...

ITEM	PART NO.	QTY.	DESCRIPTION
1	06504132	1	MOTOR (M350-1 3/4 GEAR)
2	32569	1	BELT GUARD
3	TF3044	1	UPPER SHEAVE
4	TF3040	1	LOWER SHEAVE
5	TF3013	1	BUSHING
6	28723	1	BUSHING
7	28679B	1	MOTOR CHANNEL
8	PT3611A	1	CLEVIS
9	40496	1	THREADED ROD
10	28702	2	BELT
11	TF3620A	1	TENSIONER SPRING
12	28572	1	SQUARE KEY
13	26142A	1	SQUARE KEY
14	TF4852	2	FLANGE KIT
15	30308	1	HOSE,1 X 69 - PRESSURE
16	30309	1	HOSE,1 X 78 - RETURN
17	24724	2	SWIVEL FITTING
18	TF1033	1	GREASE ZERK
19	27580	2	BUSHING
20	28682	1	MOTOR CHANNEL WASHER
21	21732	5	CAPSCREW 1/2" X 1 3/4"
22	21990	4	LOCKWASHER 1/2"
23	21725	4	HEX NUT 1/2"
24	6T2418	1	STOVER NUT 1/2"
25	21630	3	CAPSCREW 3/8" X 1"
26	22016	2	FLATWASHER 3/8"
27	21988	3	LOCKWASHER 3/8"
28	21584	6	CAPSCREW 5/16" X 2"
29	21987	6	LOCKWASHER 5/16"
30	27938	1	FLATWASHER 1/2"
31	21700	2	HEX NUT 1/2" NF
32	-----	-	CUTTER HEAD *REFER TO MOWER ASSY

COMMON LRS

63IN FLAIL MOWER ASSEMBLY

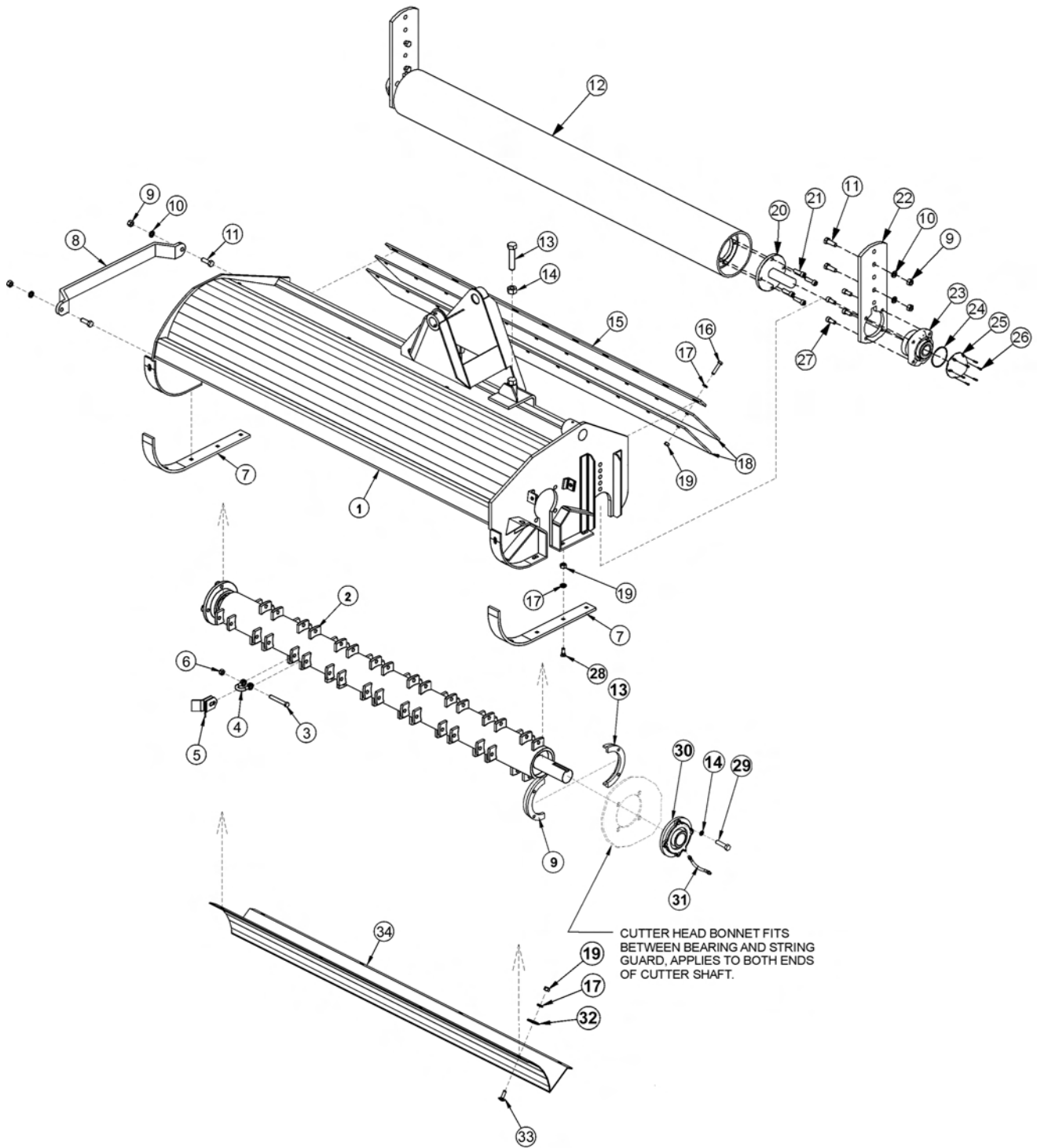

63IN FLAIL MOWER ASSEMBLY

Continued...

ITEM	PART NO.	QTY.	DESCRIPTION
//////	28422493	/	HNCN.DQOQO .85.I TCUERNV'CUU
3	4: 87; J	3	EWWVGT'J GCF'DQPPGV
4	4: 965	/	EWWVGT'UJ CHV'TMP HIG'CUUJ ""UVCP FCTF'I TCUU
//////	4: 864E	3	""EWWVGT'UJ CHV.85.UVF
5	56233	58	""HNCN'MP HIG'O QWP VRI 'DQNV
6	VH242	58	""HNCN'MP HIG'O QWP VRI 'ENGXIU
7	55935	94	""HNCN'MP HIG/'UVCP FCTF
8	43899	58	""P[NQEMPWW
9	4: 2: 8C	4	UMF'UJ QG
:	49; 97C	3	EWWVGT'UJ CHV'I WCTF
;	43947	36	J GZ'PWW'346
32	43; ; 2	36	NQEMY CUJ GT'"346
33	43953	8	ECRUETGY "'346'Z'3'346
34	4: 872C	3	I TQWPF'TQNNGT
35	55: 85	4	UVTR'I 'I WCTF.UVF
36	28755228	:	HNCVY CUJ GT'.34\$.UCG.N;
37	4: 922	3	HNCRTGVCR'R'I 'DCT
38	43855	33	ECRUETGY "'5: 6'Z'3'5166
39	43; ; :	4:	NQEMY CUJ GT"'5: 6
3:	4: 923	4	FHGNGEVQT'HNCR
3;	43847	4:	J GZ'PWW"'5: 6
42	VH267D	4	I TQWPF'TQNNGT'UVWD'UJ CHV
43	8V4552	:	ECRUETGY "'9B86'Z'3'346'UQEMGV'J GCF
44	4: 957	4	CFLWUVC DNG'TQNNGT'DTCEMGV
45	2874224:	4	DGCT'R'I .HNCPI G.3/5: .I TPFTNNT
46	2874224;	4	Q/TR'I
47	28742249	4	ECR.DGCT'R'I .I TQWPF'TQNNGT
48	28752223	34	ECRUETGY .UMV'J F.: /54'Z'34.UU
49	8V4553	:	ECRUETGY "'9B86'Z'36'UQEMGV'J GCF
4:	8V4492	32	RNQY 'DQNV"'5: 6'Z'3'3166
4;	28752439	:	ECRUETGY "'346'Z'46.N;
52	4: 8: 5	4	HNCPI G'DGCT'R'I
53	VH254	3	HNCPI G'DGCT'R'I 'I TGCUG'J QUG
54	8V4837	9	HGPFGT'Y CUJ GT"'5: 6
55	8V44: 5	9	ECTTKI G'DQNV"'5: 6'Z'36
56	4: 887C	3	DCHNG'P UFG'WRRGT'TGCT'QHEWVGT'J GCF +

COMMON LRS

3IN X 10IN WELDED CYLINDER BREAKDOWN

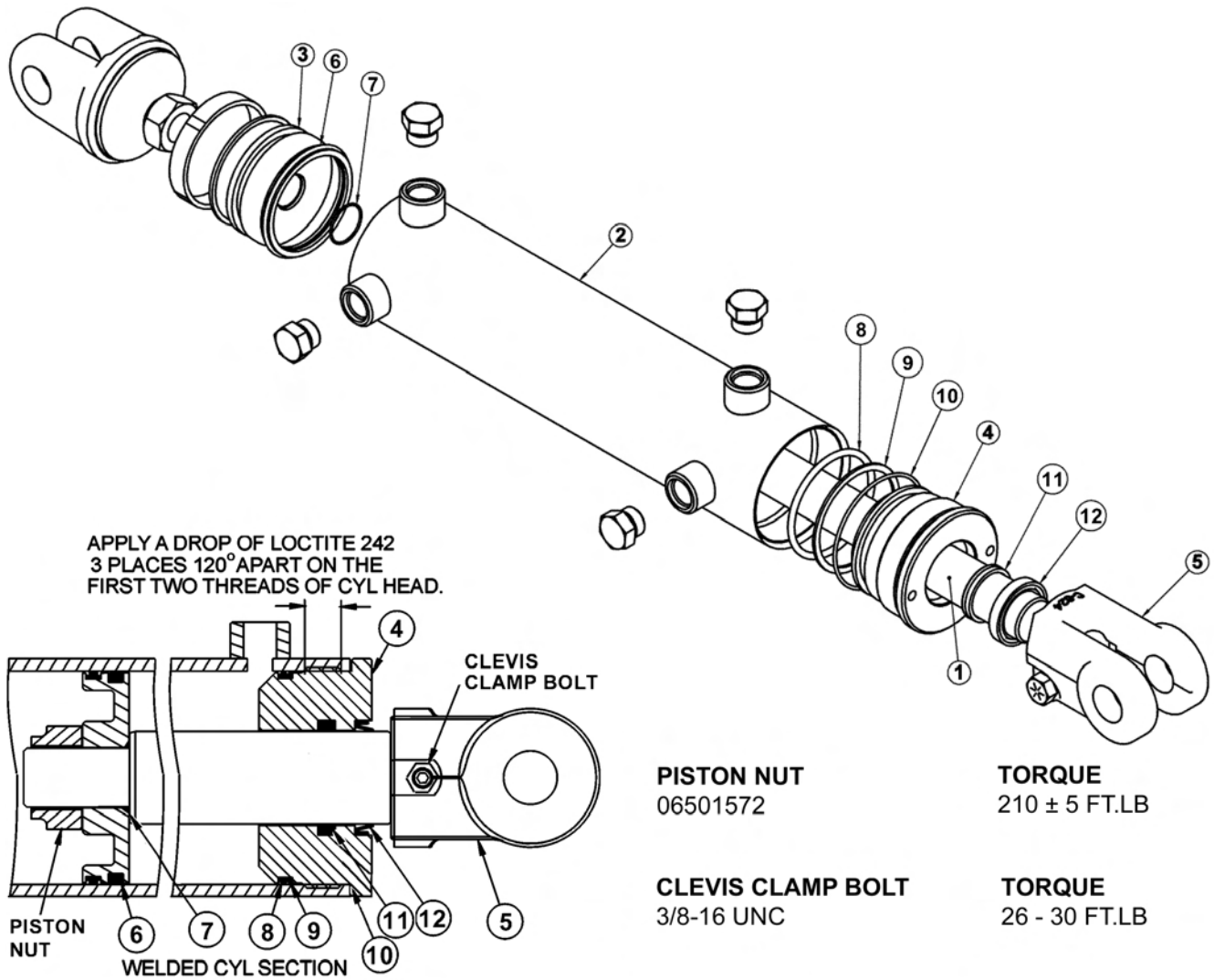

WARNING - MECHANICAL FASTENERS MUST BE TORQUED TO RECOMMENDED SPECIFICATIONS DURING REPAIR TO PREVENT PERSONAL INJURY OR EQUIPMENT DAMAGE.

ITEM	PART NO.	QTY.	DESCRIPTION
/////	28723243	/	J [FTCWNRE'E[NR PGT'EQORNGVG
3	28723772	3	TQF
4	28723773	3	VWDG'Y GNFO GP V
5	28723774	3	RKUVQP
6	28723775	3	E[NR PGT"J GCF
7	28723776	3	ENGXRU
/////	28723777	/	UGCNTGRCKT"MK"K/GO U8"VJ TQW J "34+

3IN X 18IN WELDED CYLINDER BREAKDOWN

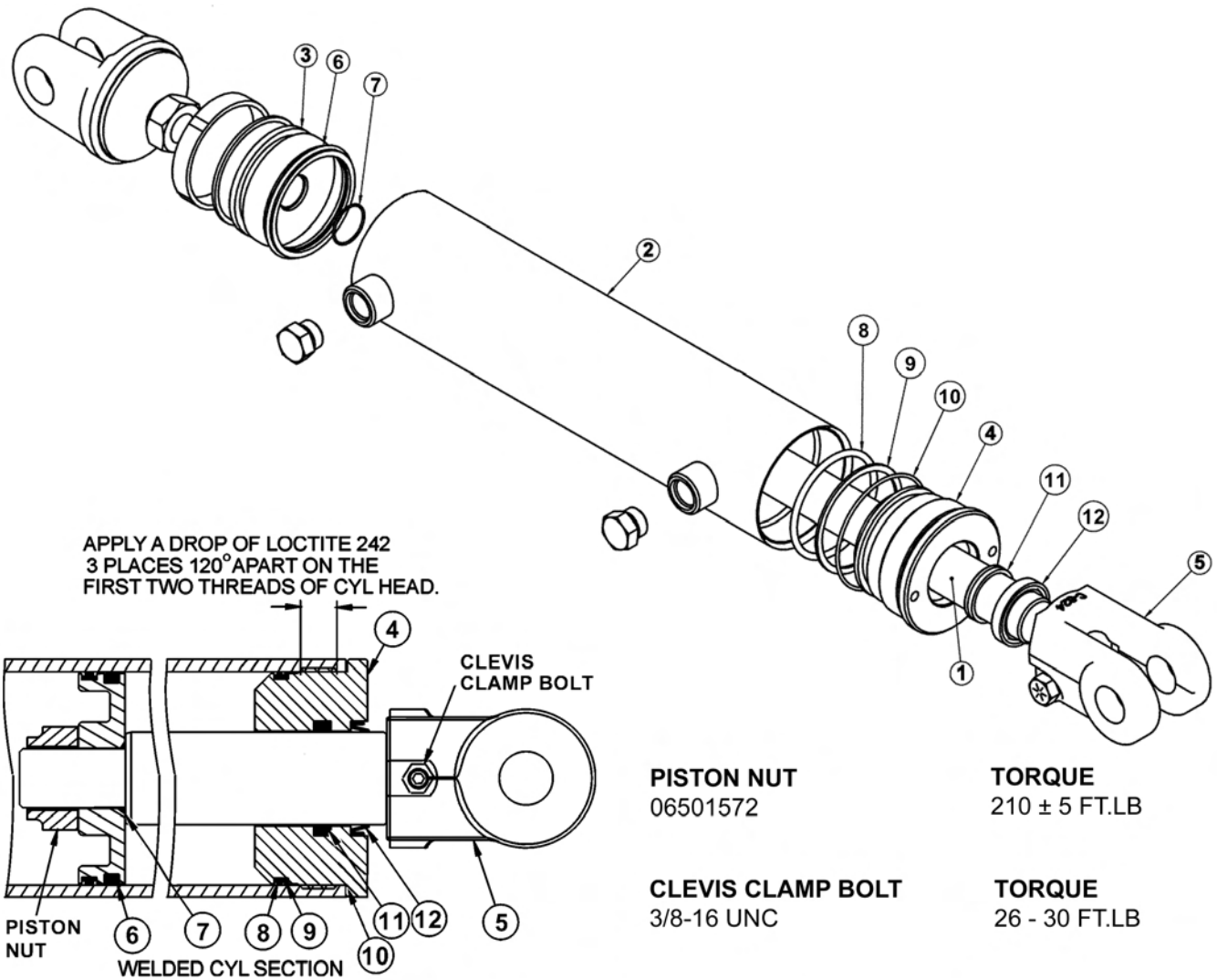

WARNING - MECHANICAL FASTENERS MUST BE TORQUED TO RECOMMENDED SPECIFICATIONS DURING REPAIR TO PREVENT PERSONAL INJURY OR EQUIPMENT DAMAGE.

ITEM	PART NO.	QTY.	DESCRIPTION
/////	28723245	/	J [F T C W N I E ' E [N I P F G T ' E Q O R N G V G
3	28723783	3	T Q F
4	28723784	3	V W D G ' Y G N F O G P V
5	28723774	3	R K U V Q P
6	28723785	3	E [N I P F G T ' J G C F
7	28723776	3	E N G X R U
/////	28723786	/	U G C N ' T G R C K ' M K ' W / G O U 8 ' V J T Q W J ' 3 4 +

3-1/2IN X 20IN WELDED CYLINDER BREAKDOWN

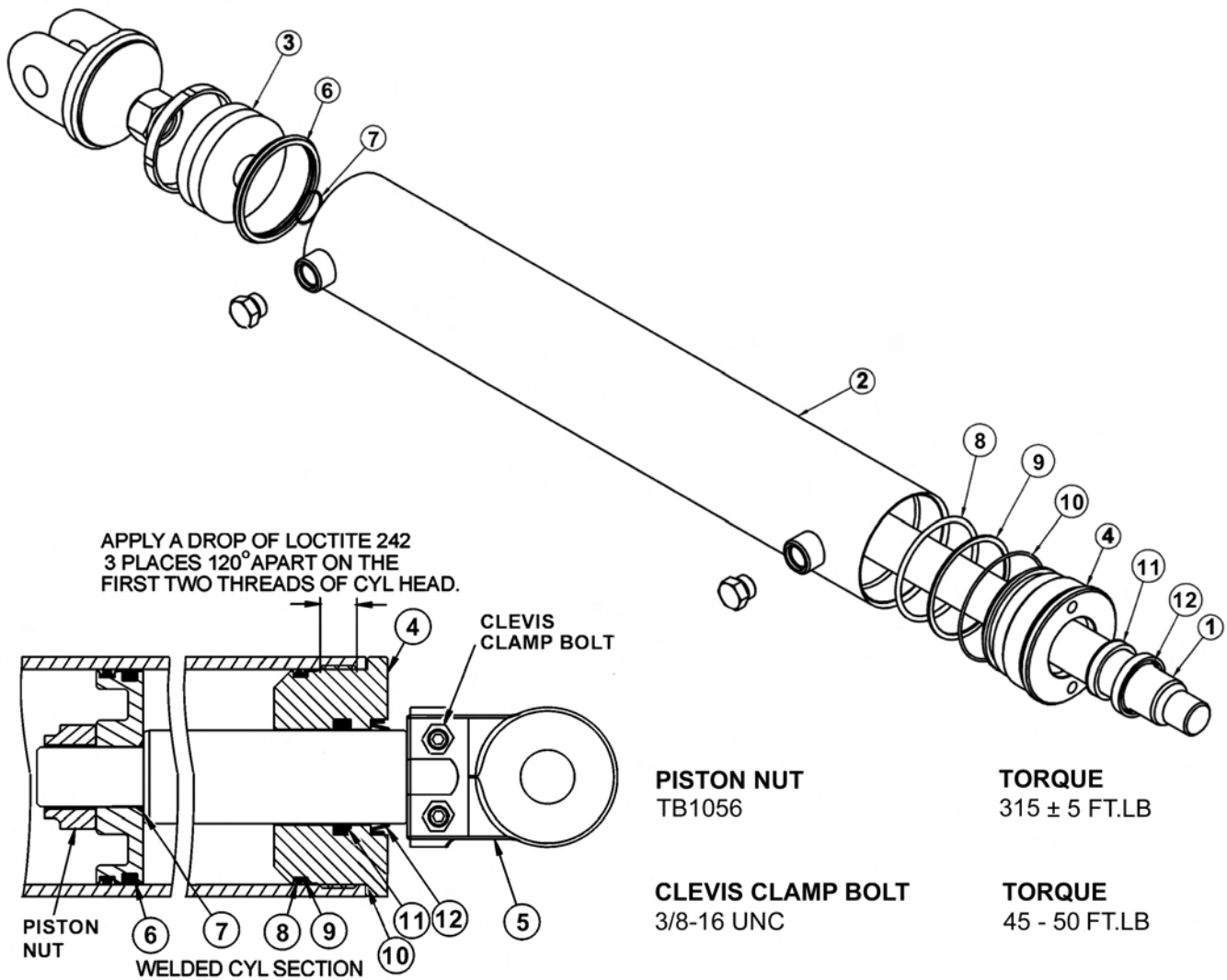

WARNING - MECHANICAL FASTENERS MUST BE TORQUED TO RECOMMENDED SPECIFICATIONS DURING REPAIR TO PREVENT PERSONAL INJURY OR EQUIPMENT DAMAGE.

ITEM	PART NO.	QTY.	DESCRIPTION
/////	28723246	/	J [F T C W N E ' E [N P F G T ' E Q O R N G V G
3	28723787	3	T Q F
4	28723788	3	V W D G ' Y G N F O G P V
5	28723789	3	R K U V Q P
6	2872378:	3	E [N P F G T ' J G C F
7	VD5255	/	E N G X R U
/////	2872378;	/	U G C N ' T G R C K T ' M K ' W G O U 8 ' V J T Q W J ' 34+

COMMON LRS

4IN X 9IN WELDED CYLINDER BREAKDOWN

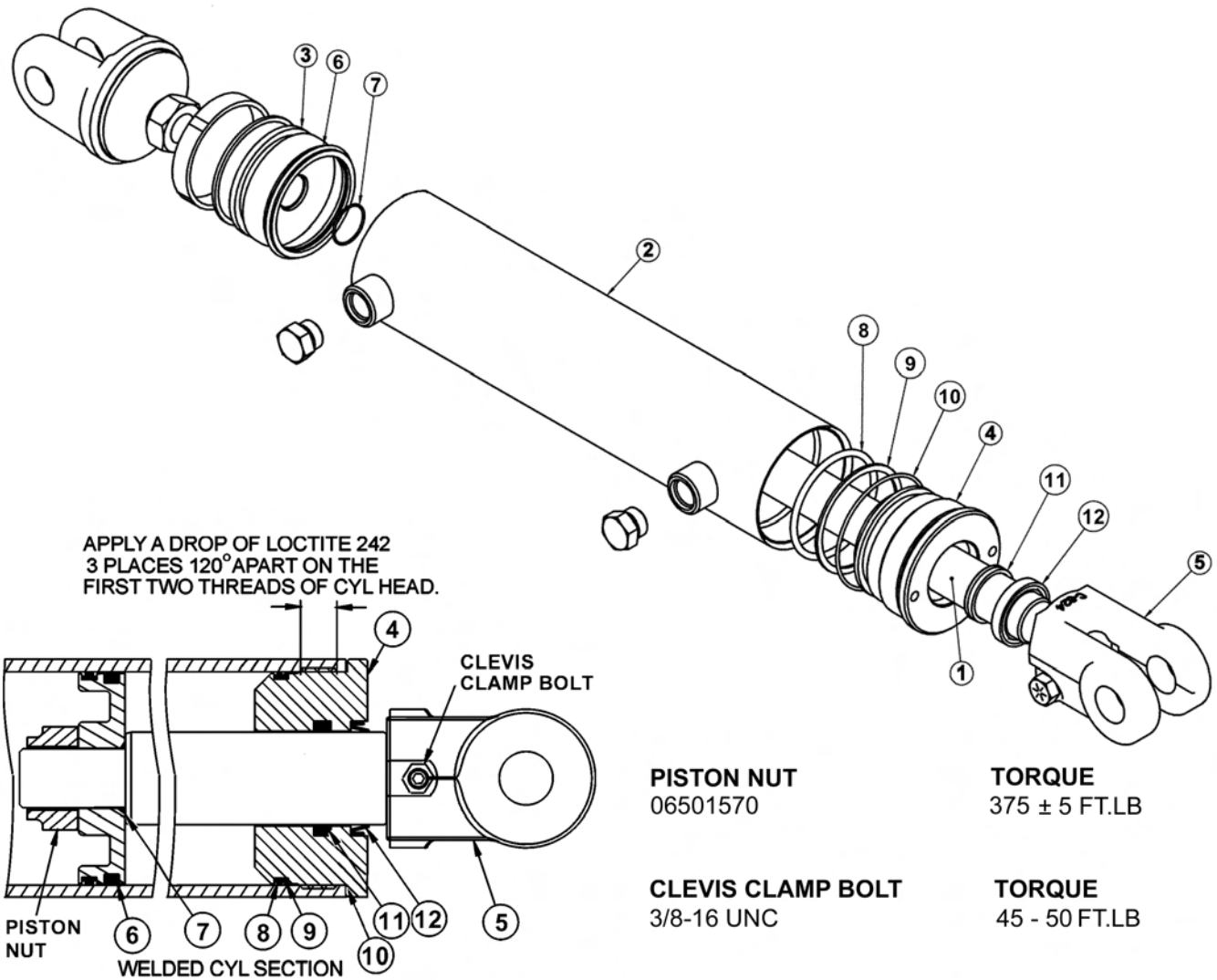

WARNING - MECHANICAL FASTENERS MUST BE TORQUED TO RECOMMENDED SPECIFICATIONS DURING REPAIR TO PREVENT PERSONAL INJURY OR EQUIPMENT DAMAGE.

ITEM	PART NO.	QTY.	DESCRIPTION
/////	2872323;	/	J [F T C W N I E ' E [N I P F G T ' E Q O R N G V G
3	2872375;	3	T Q F
4	2872375;	3	V W D G ' Y G N F O G P V
5	28723762	3	R K U V Q P
6	28723763	3	E [N I P F G T ' J G C F
7	28723764	3	E N G X R U
/////	28723765	/	U G C N T G R C K T ' M K ' W / G O U 8 ' V J T Q W J ' 34 +

COMMON LRS

4IN X 20IN WELDED CYLINDER BREAKDOWN

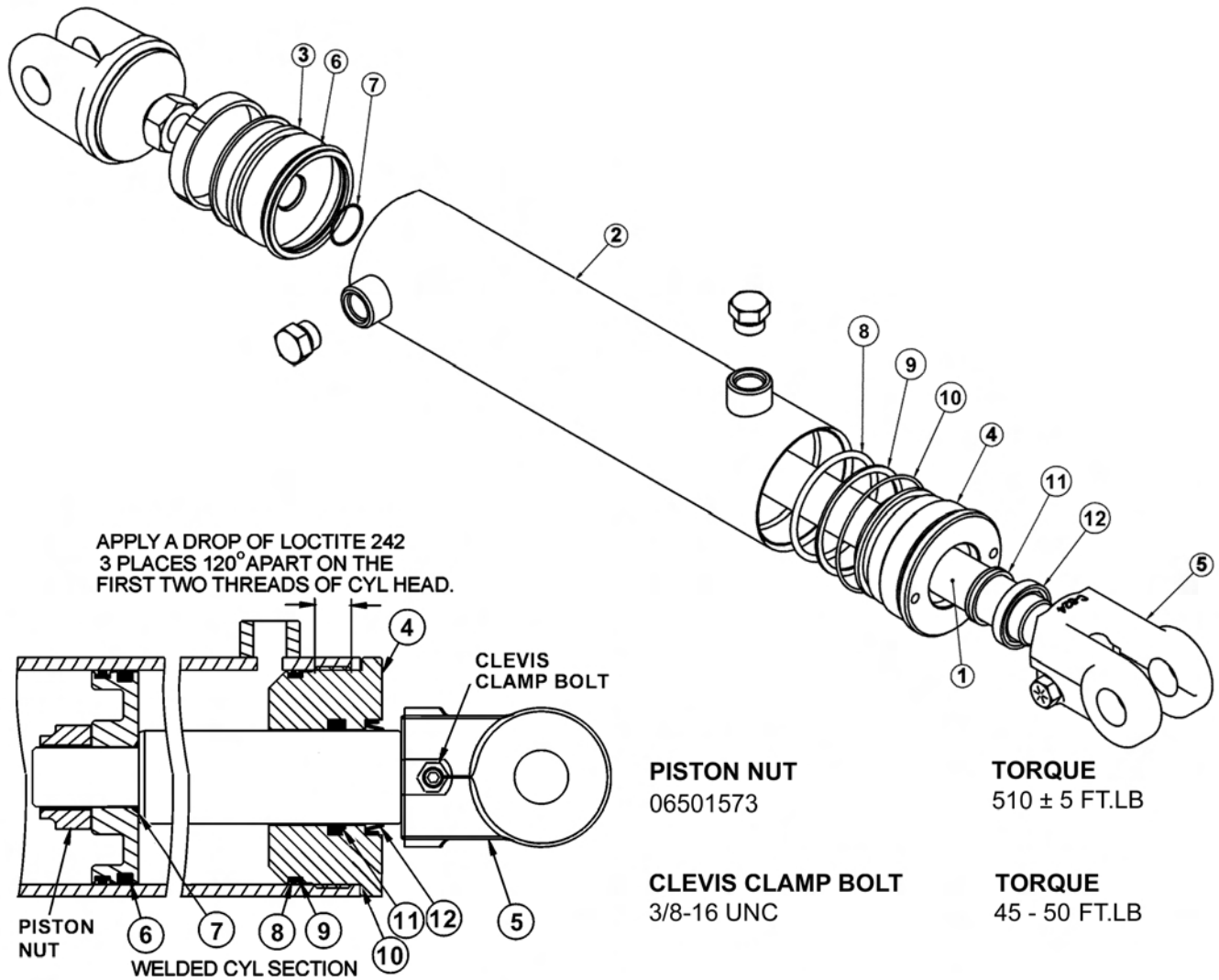

WARNING - MECHANICAL FASTENERS MUST BE TORQUED TO RECOMMENDED SPECIFICATIONS DURING REPAIR TO PREVENT PERSONAL INJURY OR EQUIPMENT DAMAGE.

ITEM	PART NO.	QTY.	DESCRIPTION
/////	28723244	/	J [F T C W N I E ' E [N I P F G T ' E Q O R N G V G
3	28723778	3	T Q F
4	28723779	3	V W D G ' Y G N F O G P V
5	2872377:	3	R K U V Q P
6	2872377;	3	E [N I P F G T ' J G C F
7	8V2394	3	E N G X I U
7C	52394	/	E N G X I U ' H Q T ' G Z V G P F G F ' D Q Q O +
/////	28723782	/	U G C N ' T G R C K T ' M K ' ' K V G O U ' 8 ' V J T Q W I J ' 34+

COMMON LRS

NOTES

COOLER ASSEMBLY

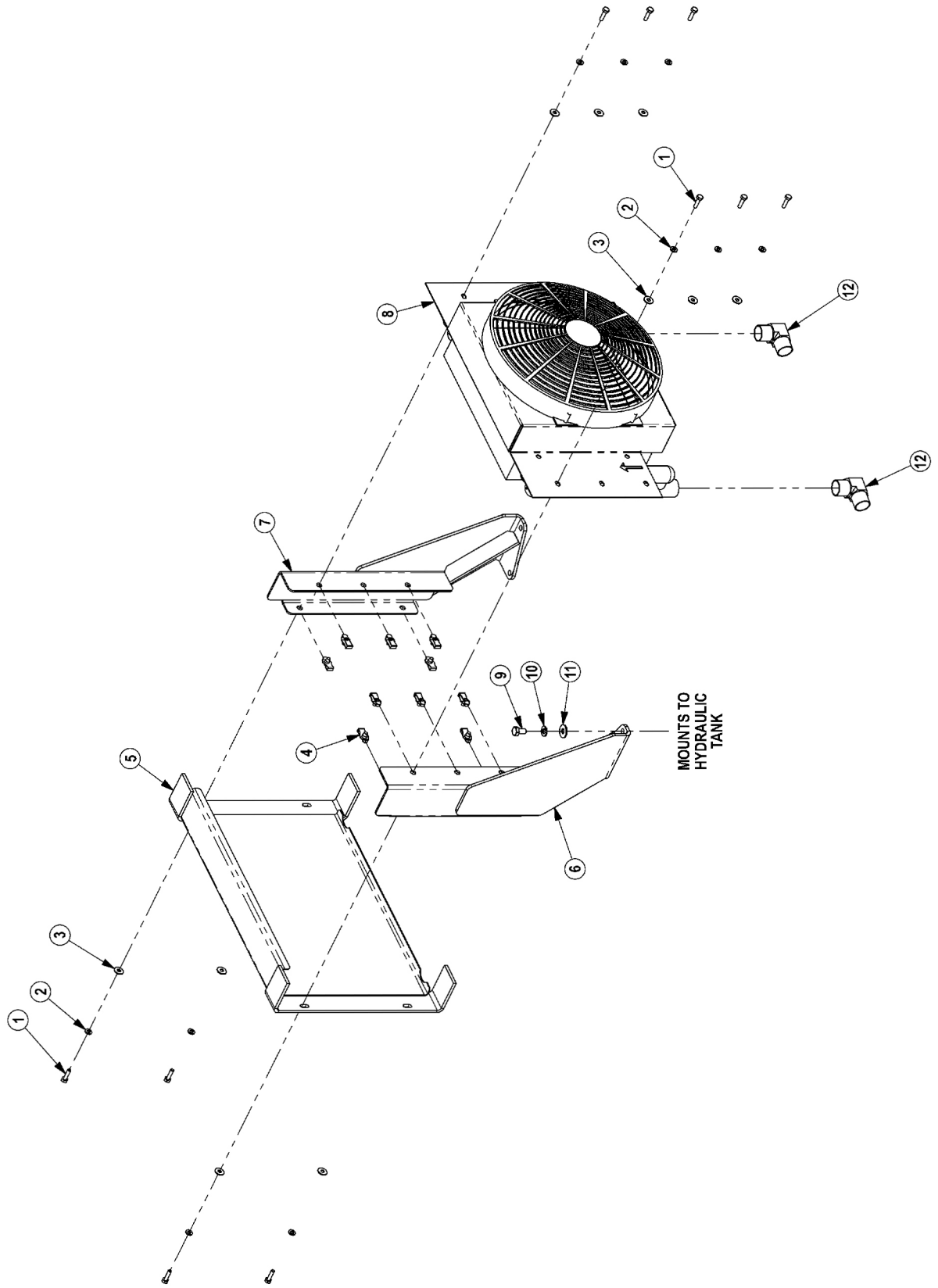

COOLER ASSEMBLY

Continued...

ITEM	PART NO.	QTY.	DESCRIPTION
1	21530	10	CAPSCREW,1/4 X 1 NC
2	21986	10	LOCKWASHER,1/4
3	22014	10	FLATWASHER,1/4
4	35176	10	1/4 U-NUT
5	06370015	1	SCREEN,COOLER,FRNT
6	06380006	1	MNT,COOLER,BUMPER TANK,RH
7	06380007	1	MNT,COOLER,BUMPER TANK,LH
8	06510026	1	COOLER,FRONT MNT
---	06510029	1	FAN ASSEMBLY ONLY
9	21629	4	CAPSCREW,3/8 X 3/4 NC
10	21988	4	LOCKWASHER,3/8
11	22016	4	FLATWASHER,3/8
12	34117	2	ELBOW,1MOR X 1MJ90,FORGED

COMMON LRS

ROTARY MOWER SPINDLE ASSEMBLY

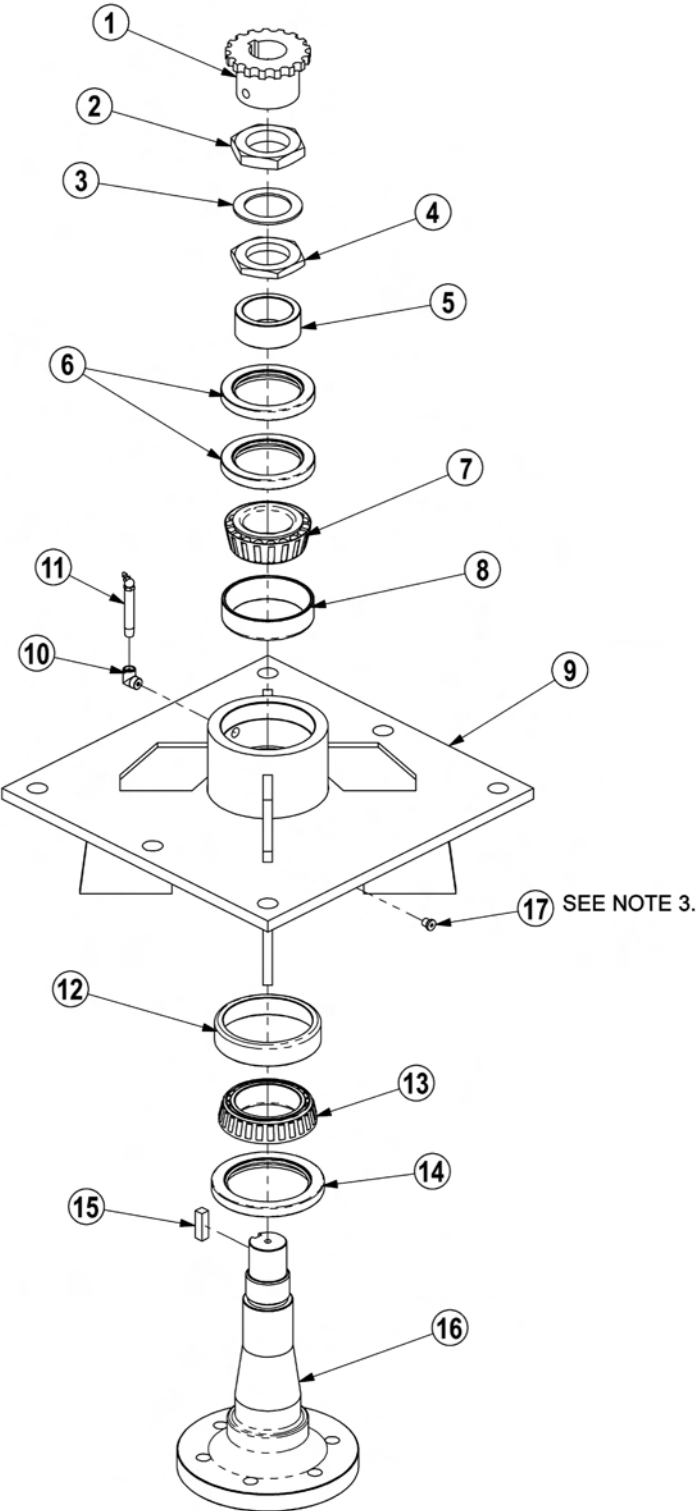

- NOTES:
1. FREEPLAY: .001" - .003"
 2. GREASE: FILL WITH MOBILITH SHC 220.
 3. APPLY LOCTITE "271" TO O-RING PLUG THRDS.

ROTARY MOWER SPINDLE ASSEMBLY

Continued...

ITEM	PART NO.	QTY.	DESCRIPTION
//////	8V3246J 7	/	URRFNG'CUUGO DN['EQO RNVG
3	8V3253	3	URTQEMGV
4	8V3238	3	DGCTRFI 'NQEMP WW/'VJ KEM
5	447; 8	3	ICO 'Y CUI GT
6	8V3237	3	DGCTRFI 'CF LWUVO GP V'P WW/'VJ R
7	8V3236	3	DGCTRFI 'CF LWUVO GP V'UNGGXG
8	8V3233	3	WRRGT'UGCNI'UGV'QH4
9	8V3234	3	DGCTRFI 'EQP G
:	8V3235	3	DGCTRFI 'EWR
;	8V3232J	3	URRFNG'J QWUR I
32	52792	3	HKVRFI 'UVTGGV'GNDQY
33	55; ; 2	3	I TGCUG\ GFM
34	8V3235J	3	DGCTRFI 'EWR
35	8V3234J	3	DGCTRFI 'EQP G
36	8V3233J	3	NQY GT'UGCNI
37	8V323;	3	URRFNG'MG[
38	RV323: J /7	3	URRFNG
39	28725286	3	Q/TR I 'RNWI .3E ö
//////	53993	/	URRFNG'TGDWKNF 'MKV'RF ENWF GU'K'GO U4'/' : 'CP F '34'/'37+

COMMON LRS

PUMP AND GRILL GUARD OPTIONS

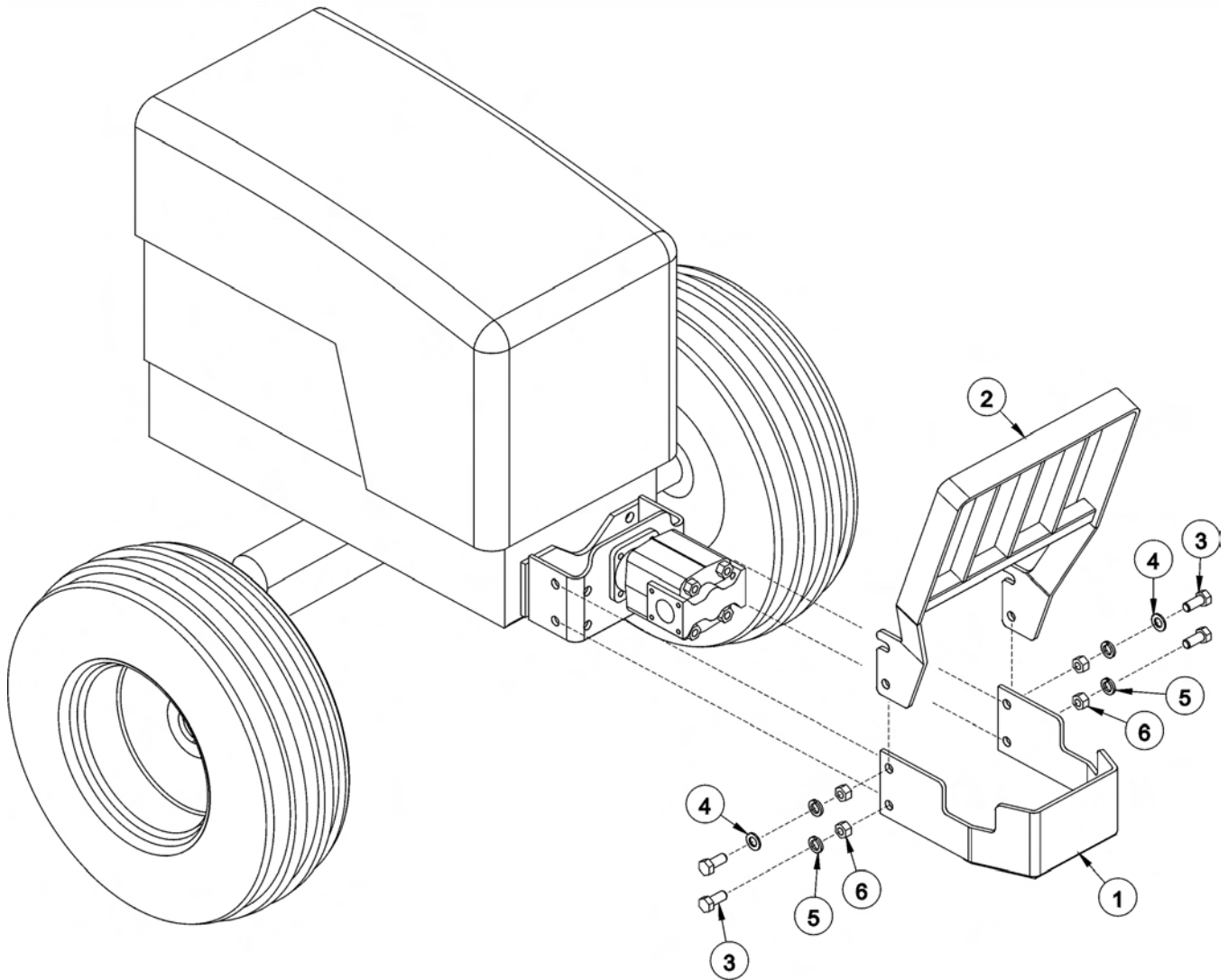

ITEM	PART NO.	QTY.	DESCRIPTION
3	54652	3	WP>UCN'RWOR'I WCTF
4	54959	3	WP>UCN'I T&NN'I WCTF
5	43: 55	6	ECRUETGY .516\$Z'4/316\$,PE
6	44243	4	HNCVY CUJ GT.516\$
7	43; ; 5	6	NQEMY CUJ GT.516\$
8	43: 47	6	J GZ'P WW.516\$,PE

COMMON LRS

RESERVOIR TANK FILTER ASSEMBLY

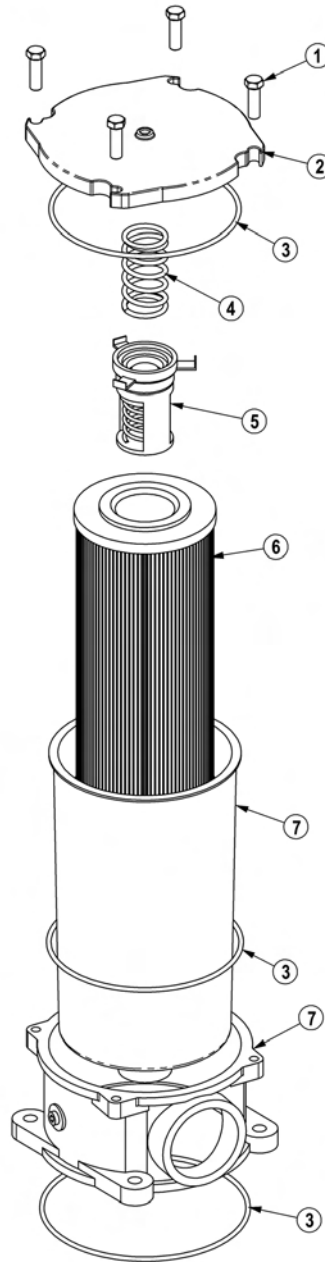

ITEM	PART NO.	QTY.	DESCRIPTION
//////	28727266	/	HKVGT"CUUj "UCG'32"O HETQP
3	4: 7: 5	6	ECRUETGY .: O O 'Z"47O O *3047"RKVEJ +
4	28727267	3	EQXGT
5	28727268	3	UGC'N'MKV
6	28727269	3	URTP I
7	2872726:	3	D[RCUU
8	5747;	3	HKVGT.32"O H.E.TGVWTP'NKG
9	2872726;	3	ECP IDQF [

COMMON LRS

5 SPOOL ELECTRONIC VALVE - BENGAL BRUTE

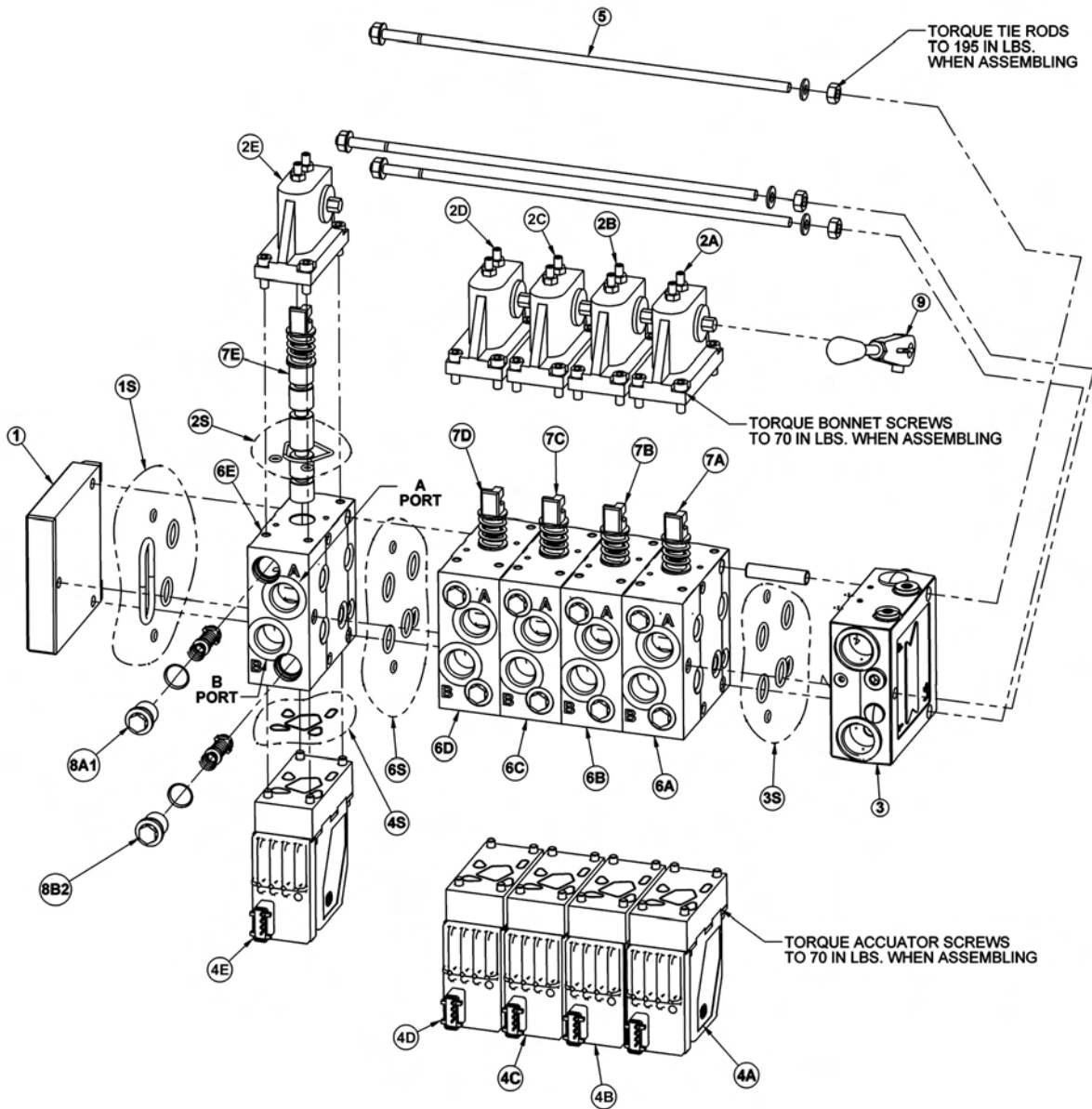

ITEM	PART NO.	QTY.	DESCRIPTION
/////	287242; 9	3	XNX.7UR.54RXI .TGCT'UVQY
3	28724296	3	GP F 'RNCVG
'''3U	28727235	3	'''GP F 'RNCVG'UGC N'MKV
4	/////	7	DQP P GV
'''4U	28727264	3	'''DQP P GV'UGC N'MKV
'''4C	643; 9	3	'''O C R' 'DQOQ 'DQP P GV
'''4D	643; 9	3	'''UGEQP F CT['DQOQ 'DQP P GV
'''4E	643; 9	3	'''F GEM TQNN'DQP P GV
'''4F	643; 9	3	'''DQOQ 'UY KGN'DQP P GV
'''4G	643; 9	3	'''F GEM'UJ KGN'DQP P GV

COMMON LRS

5 SPOOL ELECTRONIC VALVE - BENGAL BRUTE

Continued...

ITEM	PART NO.	QTY.	DESCRIPTION
5	5652:	3	R NGV UGE VQ P
""5U	28727235	3	R NGV UGE VQ P UGC N M V
6	/////	7	GNGE VT Q P K E CEE WC VQT
""6C	28724323	3	""O C R P DQ QO GNGE VT Q P K E CEE WC VQT
""6D	28724323	3	""UGE Q P F C T I DQ QO GNGE VT Q P K E CEE WC VQT
""6E	28724322	3	""F G E M T Q N N G N G E V T Q P K E C E E W C V Q T
""6F	28724323	3	""DQ QO UY K G N G N G E V T Q P K E C E E W C V Q T
""6G	287242; ;	3	""F G E M U J K G N F G N G E V T Q P K E C E E W C V Q T
7	64424	3	VIG D Q N V M V
8	/////	7	U G E V Q P
""8U	28727235	3	""U G E V Q P U G C N M V
""8C	648; ;	3	""O C R P DQ QO U G E V Q P
""8D	648; ;	3	""U G E D Q Q O U G E V Q P
""8E	28724298	3	""F G E M T Q N N U G E V Q P
""8F	648; ;	3	""DQ QO UY K G N U G E V Q P
""8G	28724299	3	""U J K G N F U G E V Q P
9	/////	7	U R Q Q N
""9C	648; 9	3	""O C R P DQ QO U R Q Q N
""9D	648; 9	3	""U G E D Q Q O U R Q Q N
""9E	6464328	3	""F G E M T Q N N U R Q Q N
""9F	28724295	3	""DQ QO UY K G N U R Q Q N
""9G	64423	3	""F G E M U J K G N F U R Q Q N
:	/////	32	C P V K E C X I U J Q E M T G N I G H
"": C3	287242: 6	3	""O C R P DQ QO C R Q T V T G N I G H
"": C4	287242: 3	3	""O C R P DQ QO D R Q T V T G N I G H
"": D3	644; 8	3	""U G E D Q Q O C R Q T V T G N I G H
"": D4	287242: 4	3	""U G E D Q Q O D R Q T V T G N I G H
"": E3	644; 7	3	""F G E M T Q N N C R Q T V T G N I G H
"": E4	287242: 4	3	""F G E M T Q N N D R Q T V T G N I G H
"": F3	28724292	3	""DQ QO UY K G N C R Q T V T G N I G H
"": F4	287242: 5	3	""DQ QO UY K G N D R Q T V T G N I G H
"": G3	287242: 3	3	""F G E M U J K G N F C R Q T V T G N I G H
"": G4	287242: 3	3	""F G E M U J K G N F D R Q T V T G N I G H
;	5567;	3	J C P F N G

COMMON LRS

5 SPOOL ELECTRONIC VALVE - PANTHER

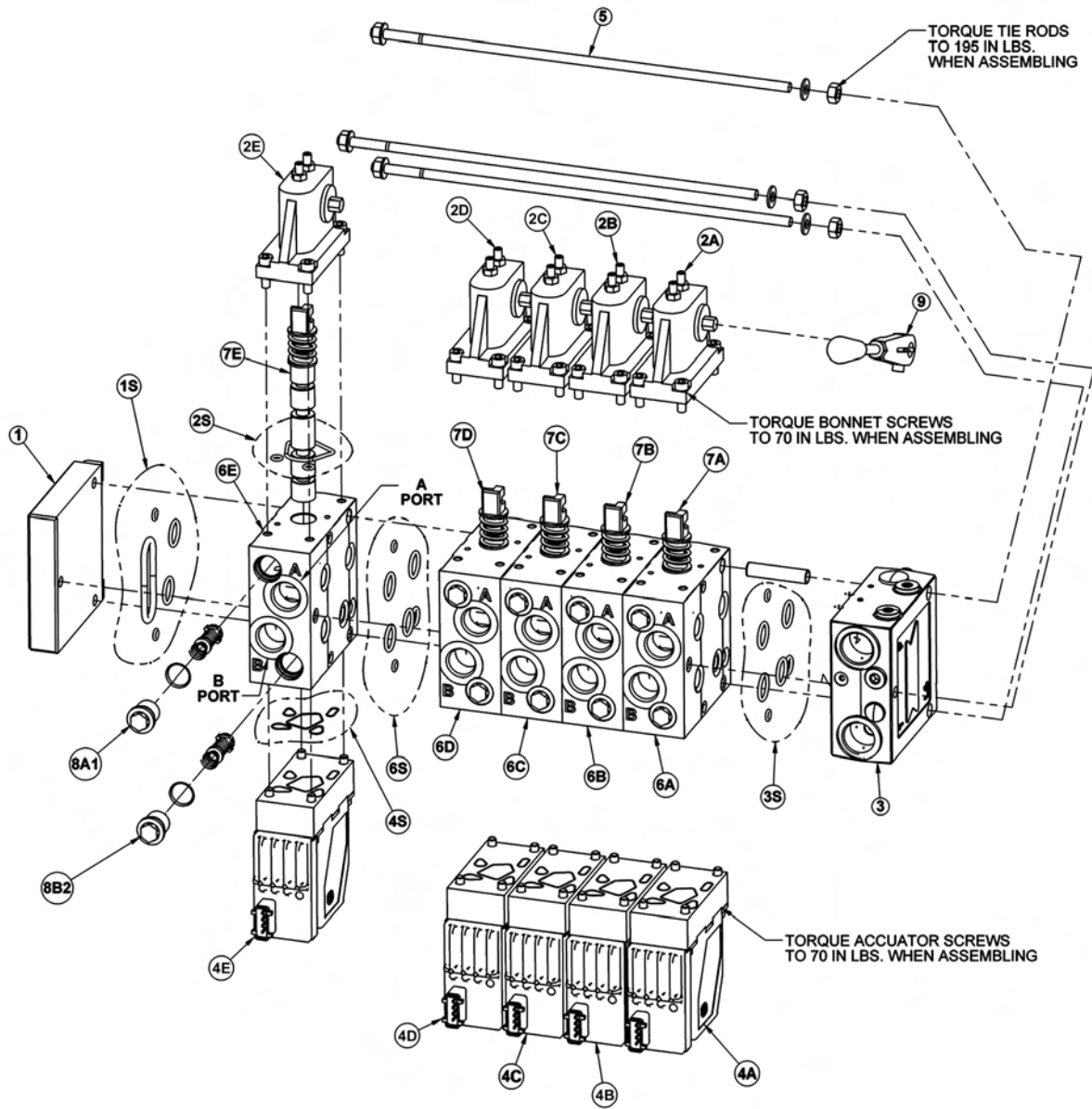

ITEM	PART NO.	QTY.	DESCRIPTION
/////	287242; 8	3	XNX.7UR.54RXI .RCP VJ GT
3	28724296	3	GP F 'RNCVG
'''3U	28727235	3	'''GP F 'RNCVG'UGC N'MKV
4	/////	7	DQP P GV
'''4U	28727264	3	'''DQP P GV'UGC N'MKV
'''4C	643; 9	3	'''O C R 'DQOQ 'DQP P GV
'''4D	643; 9	3	'''UGE Q P F CT['DQOQ 'DQP P GV
'''4E	643; 9	3	'''F GEM T QNN'DQP P GV
'''4F	643; 9	3	'''DQOQ 'UY KGN'DQP P GV
'''4G	643; 9	3	'''F GEM'UJ KGN'DQP P GV

COMMON LRS

5 SPOOL ELECTRONIC VALVE - PANTHER

Continued...

ITEM	PART NO.	QTY.	DESCRIPTION
5	5652:	3	R NGV UGE VQ P
""5U	28727235	3	""R NGV UGE VQ P UGC N M V
6	/////	7	GNGE VT Q P K E CEE WC VQT
""6C	28724323	3	""O C R 'DQ QO 'GNGE VT Q P K E CEE WC VQT
""6D	28724323	3	""UGE Q P F C T 'DQ QO 'GNGE VT Q P K E CEE WC VQT
""6E	28724322	3	""F G E M T Q N N 'GNGE VT Q P K E CEE WC VQT
""6F	28724323	3	""DQ QO 'U Y & G N 'GNGE VT Q P K E CEE WC VQT
""6G	287242; ;	3	""F G E M U J K G N F 'GNGE VT Q P K E CEE WC VQT
7	64424	3	VIG D Q N V M V
8	/////	7	U G E V Q P
""8U	28727235	3	""U G E V Q P U G C N M V
""8C	648; ;	3	""O C R 'DQ QO 'U G E V Q P
""8D	648; ;	3	""U G E 'DQ QO 'U G E V Q P
""8E	28724298	3	""F G E M T Q N N 'U G E V Q P
""8F	648; ;	3	""DQ QO 'U Y & G N 'U G E V Q P
""8G	28724299	3	""U J K G N F 'U G E V Q P
9	/////	7	U R Q Q N
""9C	648; 9	3	""O C R 'DQ QO 'U R Q Q N
""9D	648; 9	3	""U G E 'DQ QO 'U R Q Q N
""9E	6464328	3	""F G E M T Q N N 'U R Q Q N
""9F	28724295	3	""DQ QO 'U Y & G N 'U R Q Q N
""9G	64423	3	""F G E M U J K G N F 'U R Q Q N
:	/////	32	C P V K E C X I U J Q E M T G N I G H
"": C3	64872	3	""O C R 'DQ QO 'C 'R Q T V T G N I G H
"": C4	2872428;	3	""O C R 'DQ QO 'D 'R Q T V T G N I G H
"": D3	64872	3	""U G E 'DQ QO 'C 'R Q T V T G N I G H
"": D4	644; 7	3	""U G E 'DQ QO 'D 'R Q T V T G N I G H
"": E3	644; 8	3	""F G E M T Q N N 'C 'R Q T V T G N I G H
"": E4	644; 7	3	""F G E M T Q N N 'D 'R Q T V T G N I G H
"": F3	644; 7	3	""DQ QO 'U Y & G N 'C 'R Q T V T G N I G H
"": F4	644; 7	3	""DQ QO 'U Y & G N 'D 'R Q T V T G N I G H
"": G3	2872428;	3	""F G E M U J K G N F 'C 'R Q T V T G N I G H
"": G4	2872428;	3	""F G E M U J K G N F 'D 'R Q T V T G N I G H
;	5567;	3	J C P F N G

COMMON LRS

FRONT HYDRAULIC PUMP

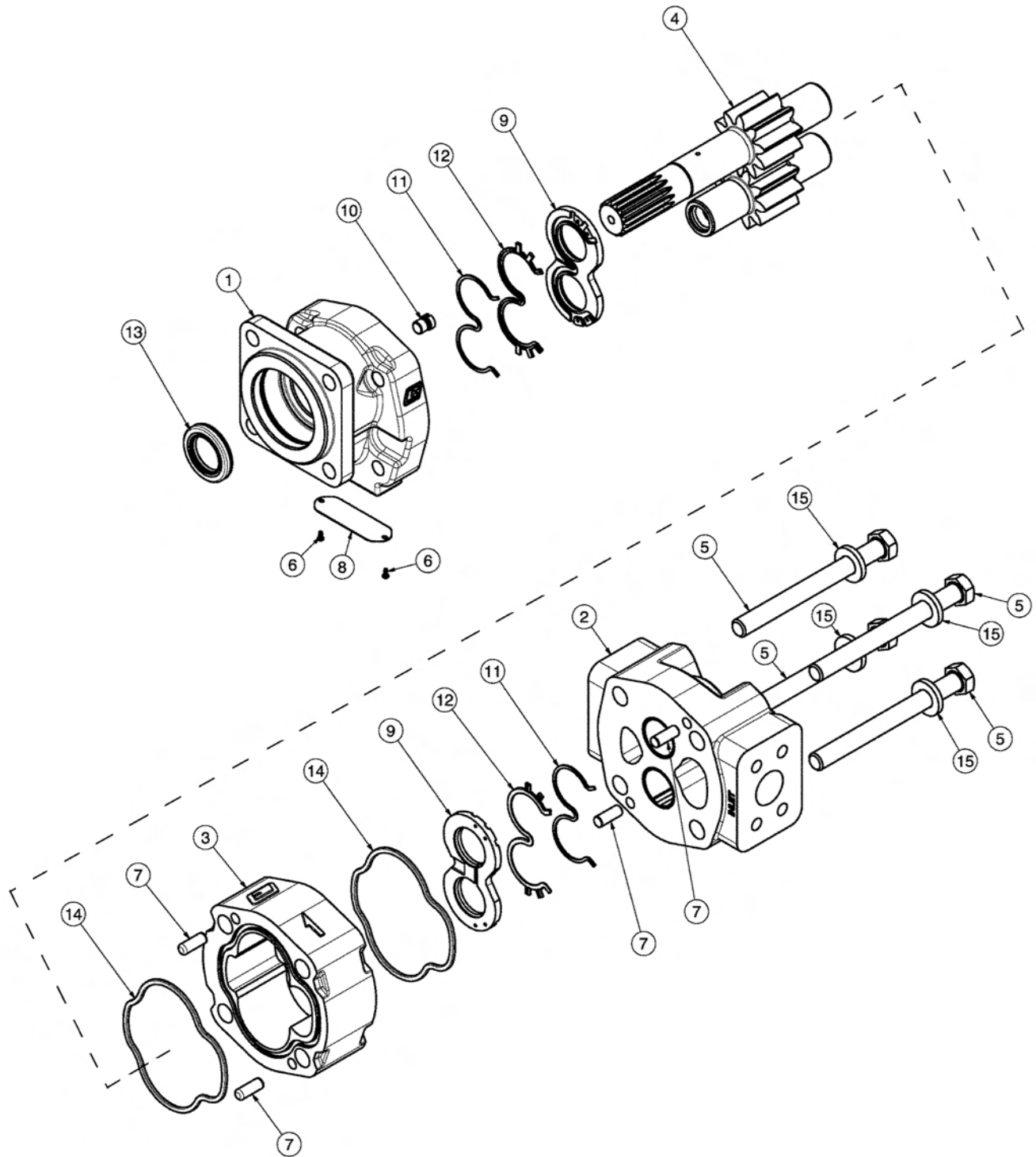

COMMON LRS

FRONT HYDRAULIC PUMP

Continued...

ITEM	PART NO.	QTY.	DESCRIPTION
///	45374	3	RWO R'CUUGO DN[.3/5 166.EQO RNGVG
3	44988	3	UJ CHV'GP F'EQXGT
4	4499;	3	RQT V'GP F'EQXGT
5	44996	3	I GCT'J QWUR I .3/5 166
6	44993	3	I GCT'UGV
7	45: 46	6	ECRUETGY
8	2872629:	4	UETGY .FT&G
9	44995	6	FQY GN'R U
:	28726299	3	P CO GRNCVG
;	44992	4	VJ TWU' RNCVG
32	44989	3	RNWI
33	28726297	4	UGC.N.DM'WR
34	28726296	4	UGC.N.EJ CP
35	44987	3	UGC.N.NR
36	28726298	4	UGC.N.US /T
37	24; 83; 39	6	Y CUJ GT
///	46372	3	UGC.N.MK' "R ENWF GU'33.'34.'35'CP F"36+

COMMON LRS

50IN AND 60IN ROTARY MOTOR BREAKDOWN

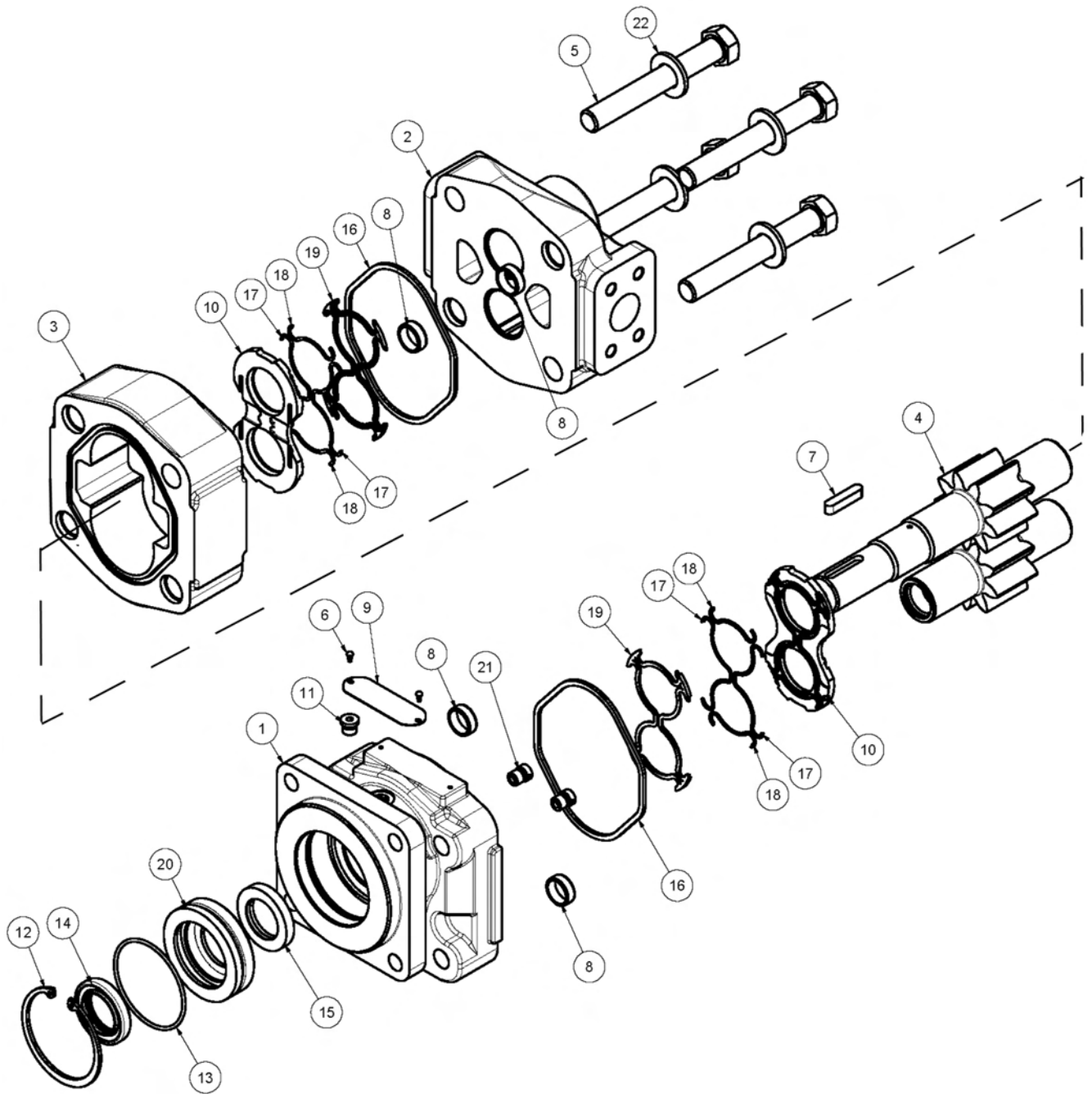

COMMON LRS

50IN AND 60IN ROTARY MOTOR BREAKDOWN

Continued...

ITEM	PART NO.	QTY.	DESCRIPTION
	06504011	-	MOTOR ASSEMBLY,TRB60
	06504012	-	MOTOR ASSEMBLY,TRB50
1	22790	1	HOUSING, SEC
2	06504088	1	HOUSING, PEC
3	06504062	1	HOUSING, GEAR,TRB60
-----	06504089	-	HOUSING, GEAR,TRB50
4	06504090	1	SET, GEAR SHAFT
5	06504104	4	CAP SCREW,TRB60
-----	06504091	-	CAP SCREW,TRB50
6	06504078	2	SCREW, DRIVE
7	06504092	1	KEY
8	06504093	4	PIN, DOWEL
9	06504094	1	NAME PLATE
10	06504095	2	THRPL
11	2961940	1	PLUG, ODT
12	2962200	1	RING, SNAP
13	06504096	1	O RING
14	6T5101	1	SEAL, LIP
15	06504097	1	SEAL, LIP
16	22797	2	SEAL, SQ-R
17	06504098	4	SEAL, SIDE CHAN
18	06504099	4	SEAL, END CHAN
19	06504100	2	SEAL, BK-UP
20	06504101	1	RTNR, SEAL
21	6T5809	2	CHECK ASS'Y
22	06504102	4	WASHER
-----	06504103	-	SEAL KIT

COMMON LRS

50IN AND 63IN FLAIL MOTOR BREAKDOWN

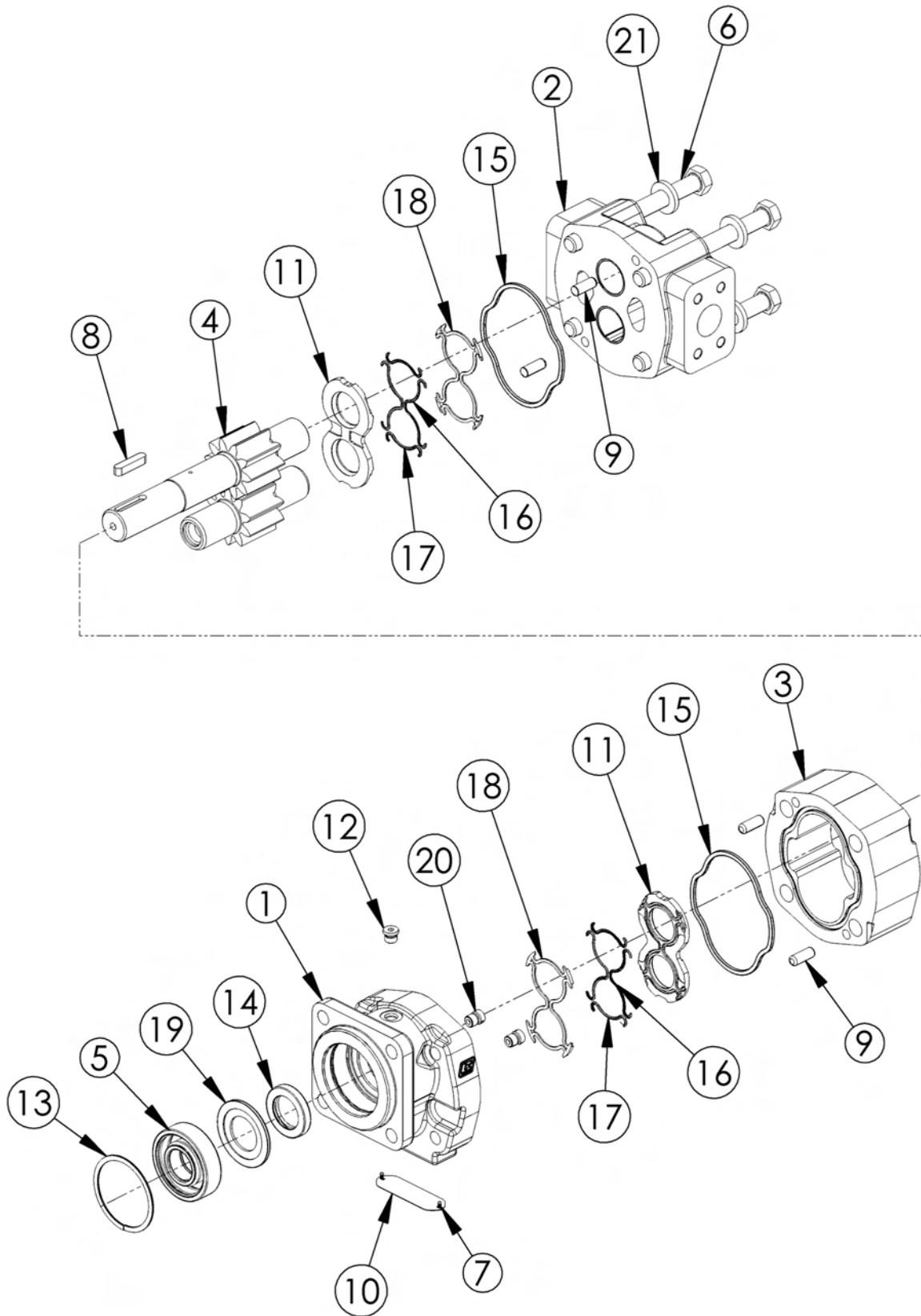

COMMON LRS

50IN AND 63IN FLAIL MOTOR BREAKDOWN

Continued...

ITEM	PART NO.	QTY.	DESCRIPTION
-----	06504013	-	MOTOR ASSEMBLY 350 - TBF50, TBF63
1	06504039	1	SHAFT END COVER
2	06504040	1	PORT END COVER
3	06504041	1	GEAR HOUSING
4	06504042	1	MATCHED GEAR SET
5	TF4402	1	BALL BEARING
6	06504043	4	CAP SCREW
7	06504044	2	SET SCREW
8	06504028	1	KEY
9	06504045	4	DOWEL PIN
10	-----	1	NAMEPLATE
11	763759	2	THRUSTPLATE
12	02961940	1	HEX PLUG
13	TF4401	1	SNAP RING
14	06504049	1	LIP SEAL
15	TF4410	2	GASKET SEAL
16	06504046	4	SIDE SEAL
17	06504047	4	END SEAL
18	TF4407	2	BACK-UP SEAL
19	06504048	1	SEAL RETAINER
20	6T5809	2	CHECK ASSEMBLY
21	02961917	4	WASHER
-----	06504023	-	SEAL KIT (INCLUDES 14, 15, 16, 17, AND 18)

COMMON LRS

MANUAL LIFT VALVE SWITCH BOX

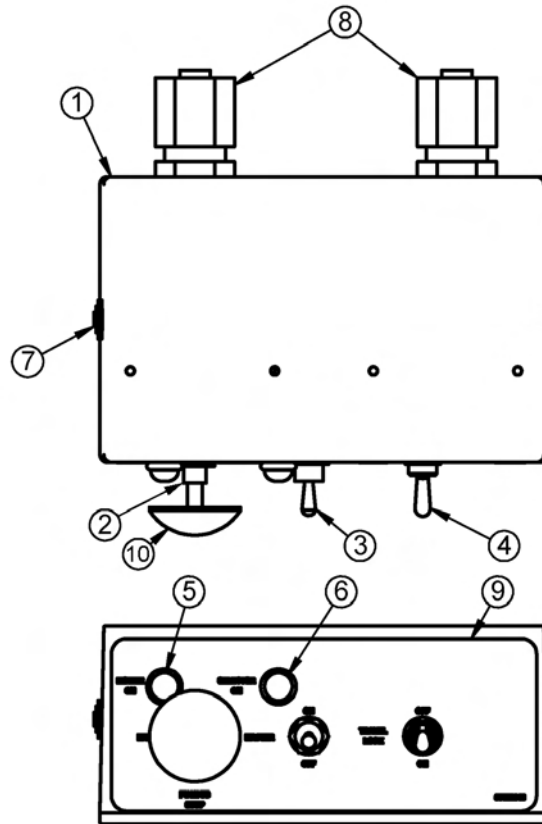

ITEM	PART NO.	QTY.	DESCRIPTION
1	06514010	1	SWBX, ASSY
2	35226	2	SWITCH, MOWER, COLEHERSEE
3	33811	1	SWITCH, MASTER/DECK FLOAT
4	34532	1	SWITCH, TRVL LCK
5	6T3923	1	INDICATOR LIGHT, ON, RED
6	06510193	1	INDICTATOR LIGHT, ON, GREEN
7	06514006	1	BREAKER, 15A, SWBX
8	34540	2	STRAIN RELIEF
9	06550043	1	DECAL, SWTCHBX
10	02964063	1	KNOB, RED
11	35227	1	RELAY, DP, DT, 12V, LY2F (NOT SHOWN)

MANUAL LIFT VALVE SCHEMATIC

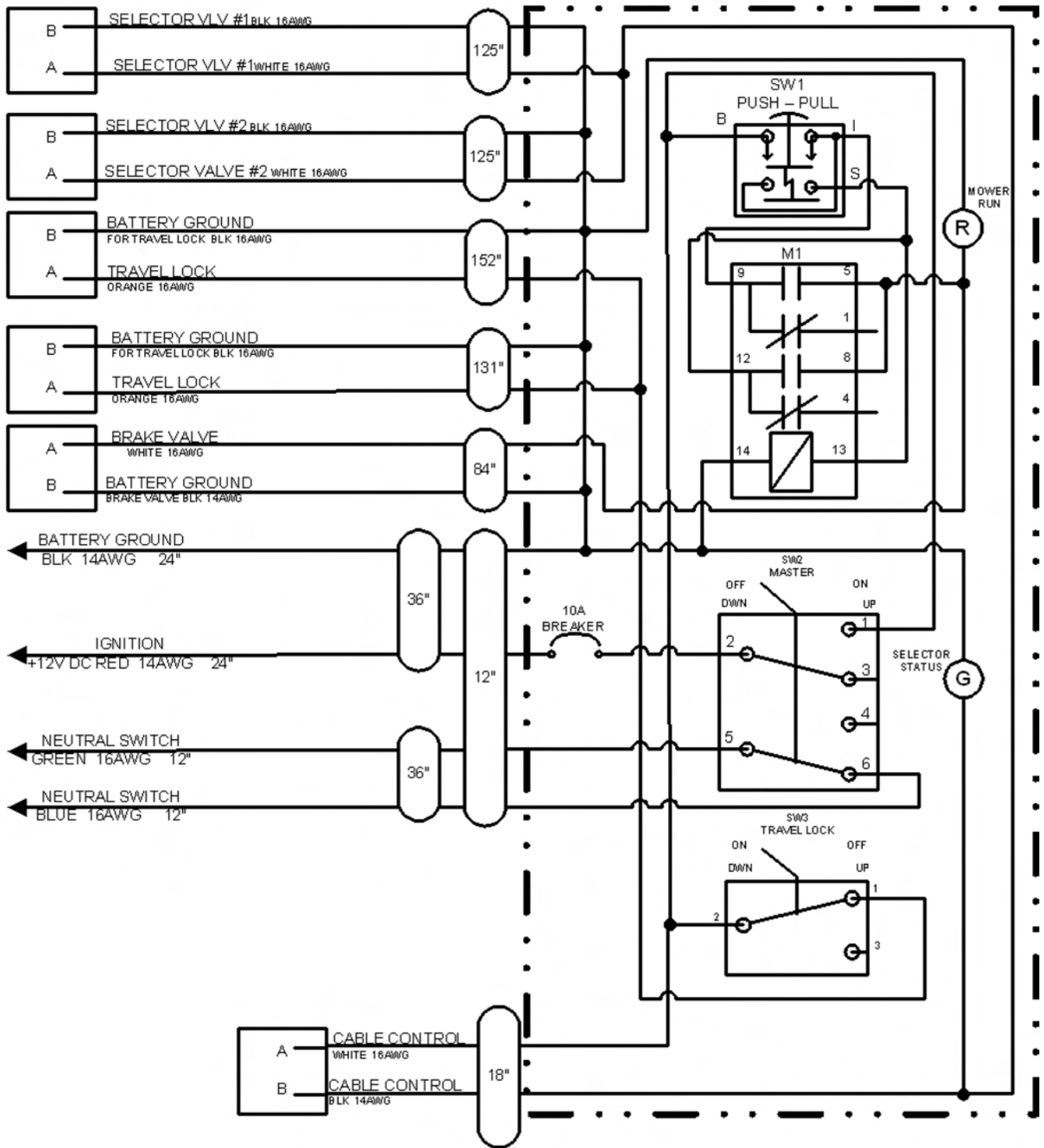

ELECTRONIC LIFT VALVE SWITCH BOX

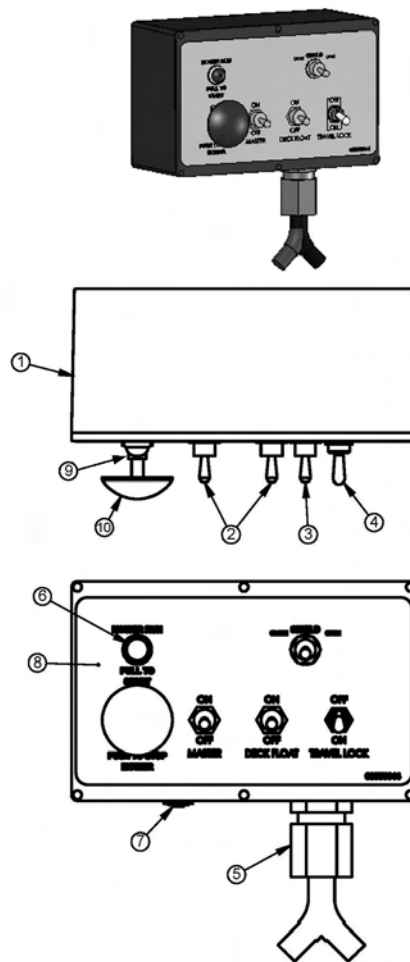

ITEM	PART NO.	QTY.	DESCRIPTION
1	06510195	1	SWBX,ASSY
2	33811	2	SWITCH,MASTER/DECK FLOAT
3	33813	1	SWITCH,SFTY SHIELD
4	34532	1	SWITCH,TRVL LCK
5	34540	1	STRAIN RELIEF,3/4",BLACK,NYLON
6	6T3923	1	INDICTATOR LIGHT,ON,RED
7	06514006	1	BREAKER,15A,SWBX
8	06550044	1	DECAL,SWBX,06510047
9	35226	1	SWITCH,MOWER,COLEHERSEE
10	35227	1	RELAY,DP,DT,12V,LY2F,35226

COMMON LRS

ELECTRONIC LIFT VALVE SCHEMATIC - REAR STOW

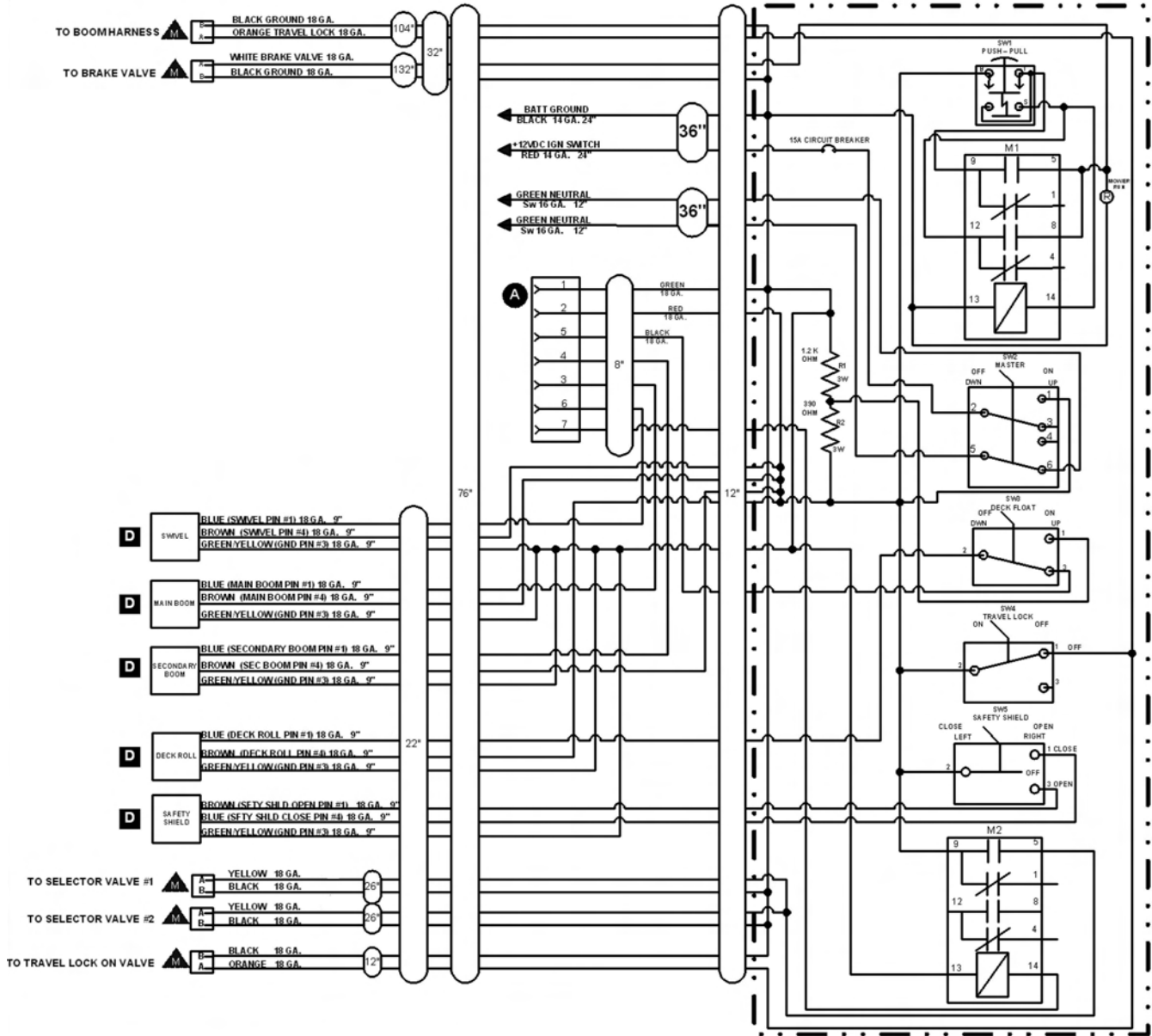

ELECTRONIC LIFT VALVE WIRING DIAGRAM

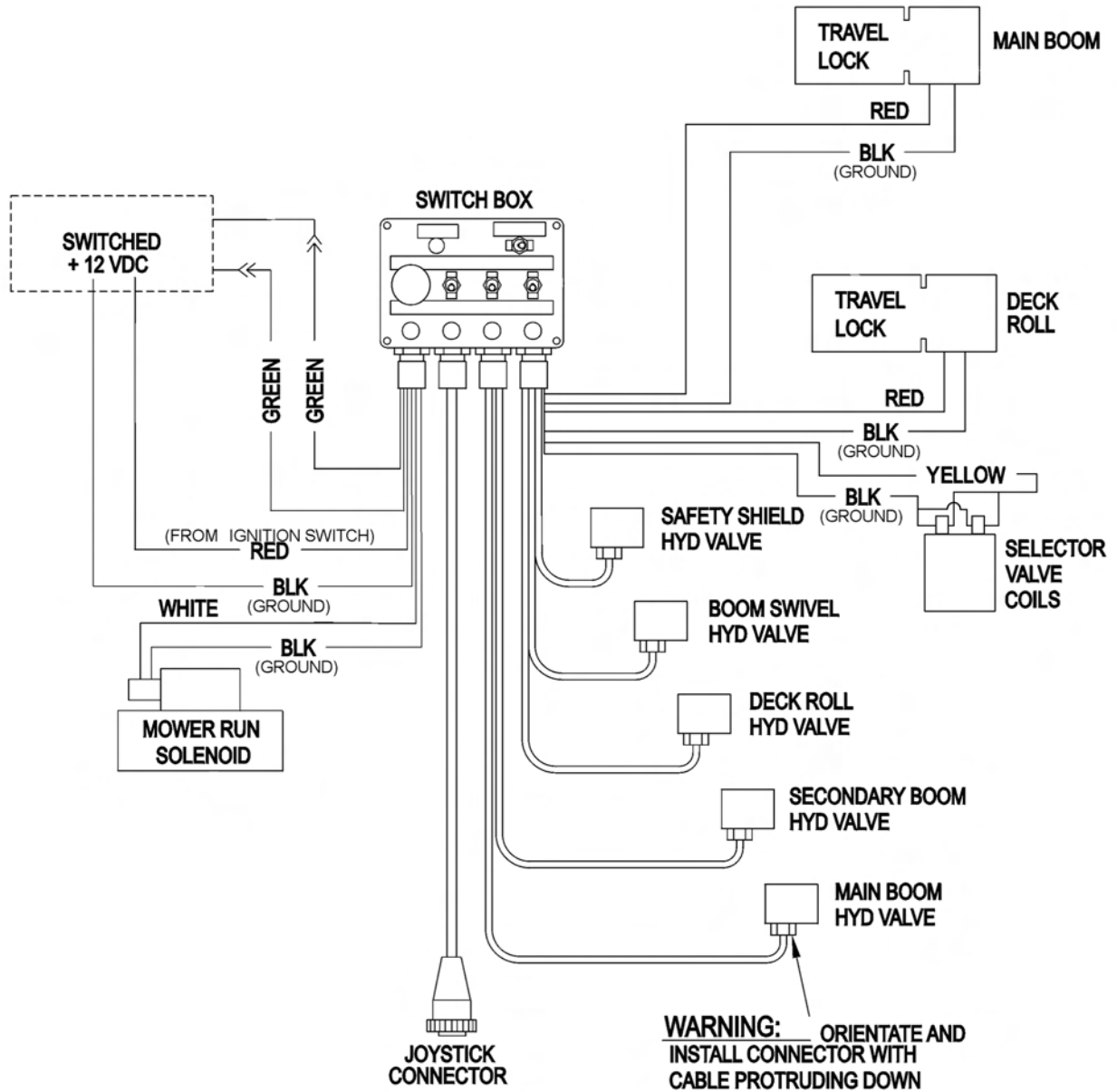

BOOM TRAVEL LOCK

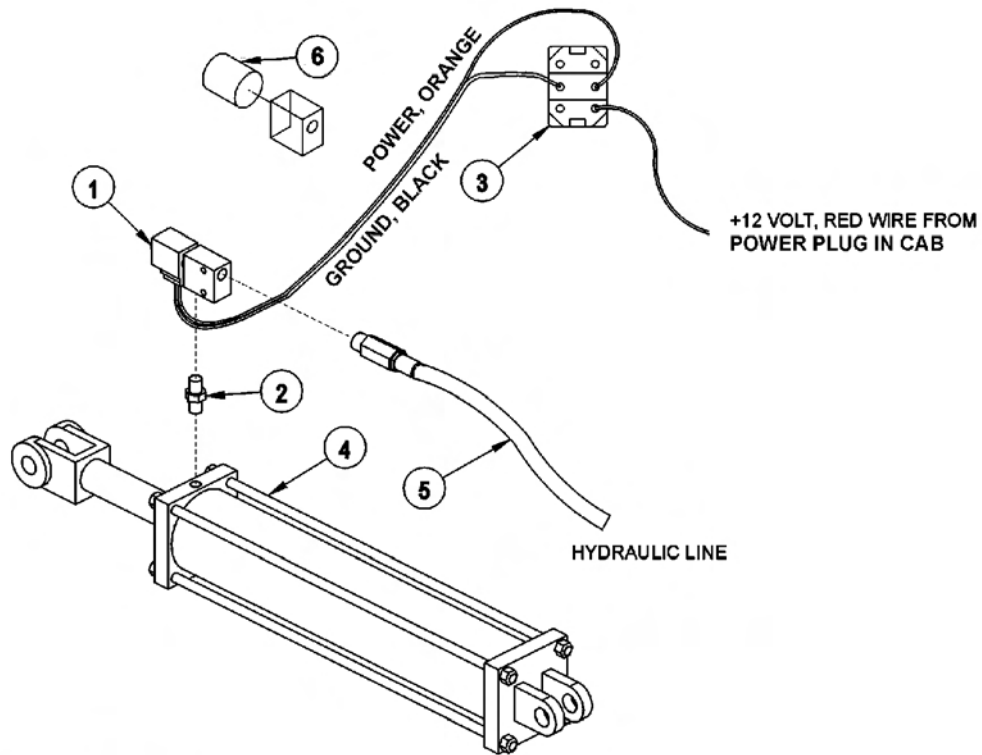

DANFOSS SWITCH BOX



TRAVEL LOCK
SWITCH

HUSCO SWITCH BOX



TRAVEL LOCK
SWITCH

ITEM	PART NO.	QTY.	DESCRIPTION
1	06510050	1	HYDRAULIC TRAVEL LOCK VALVE
2	31329	1	ADAPTER - STANDARD BOOM
3	34532	1	SWITCH,TRAVEL LOCK
4	-----	-	MAIN BOOM CYLINDER *REFER TO BOOM ASSY
5	-----	-	HOSE / FITTINGS *REFER TO BOOM HYD ASSY
6	06510092	1	COIL ,TRAVEL LOCK

COMMON LRS

SELECTOR VALVE SCHEMATIC

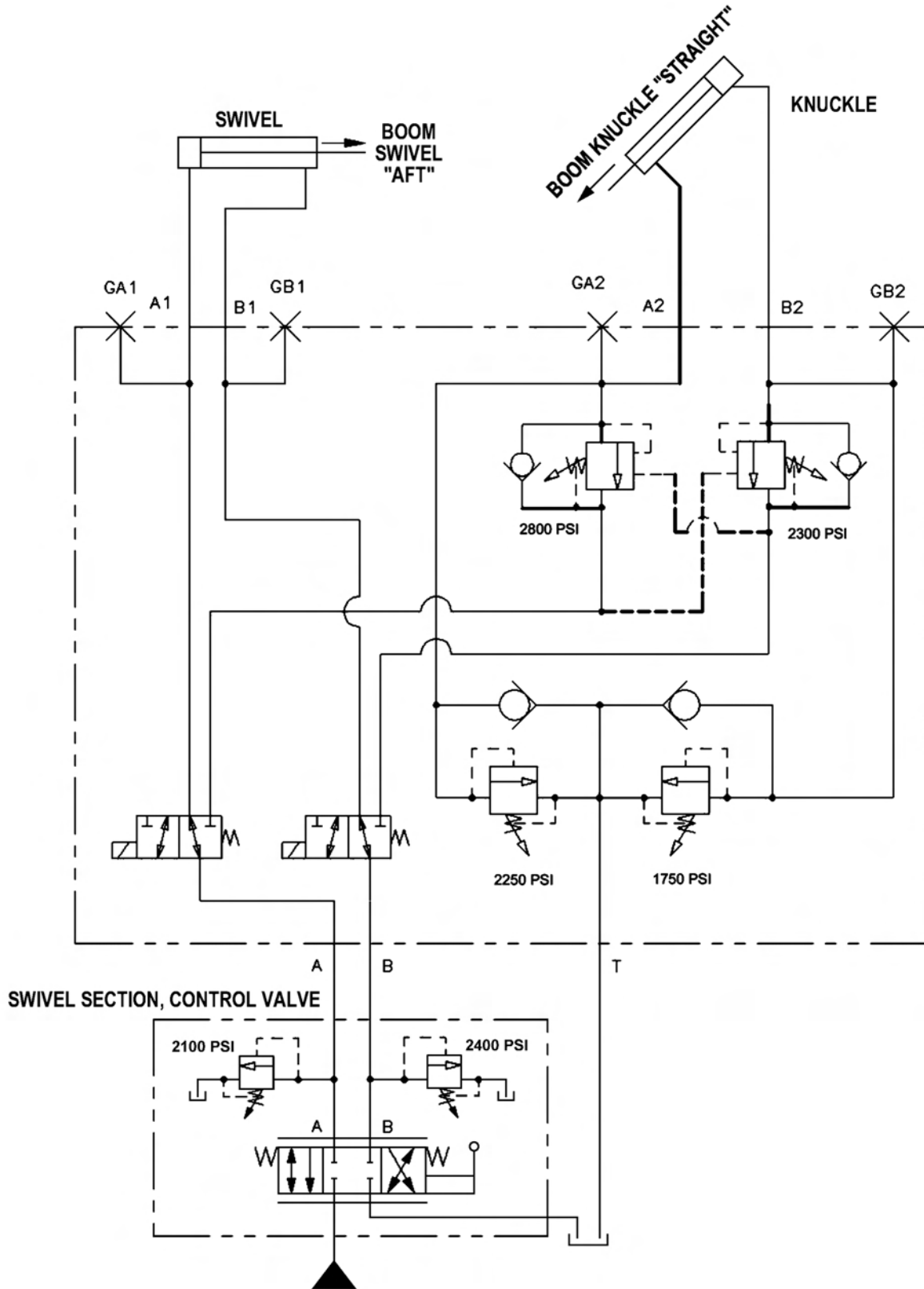

BRAKE VALVE ASSEMBLY

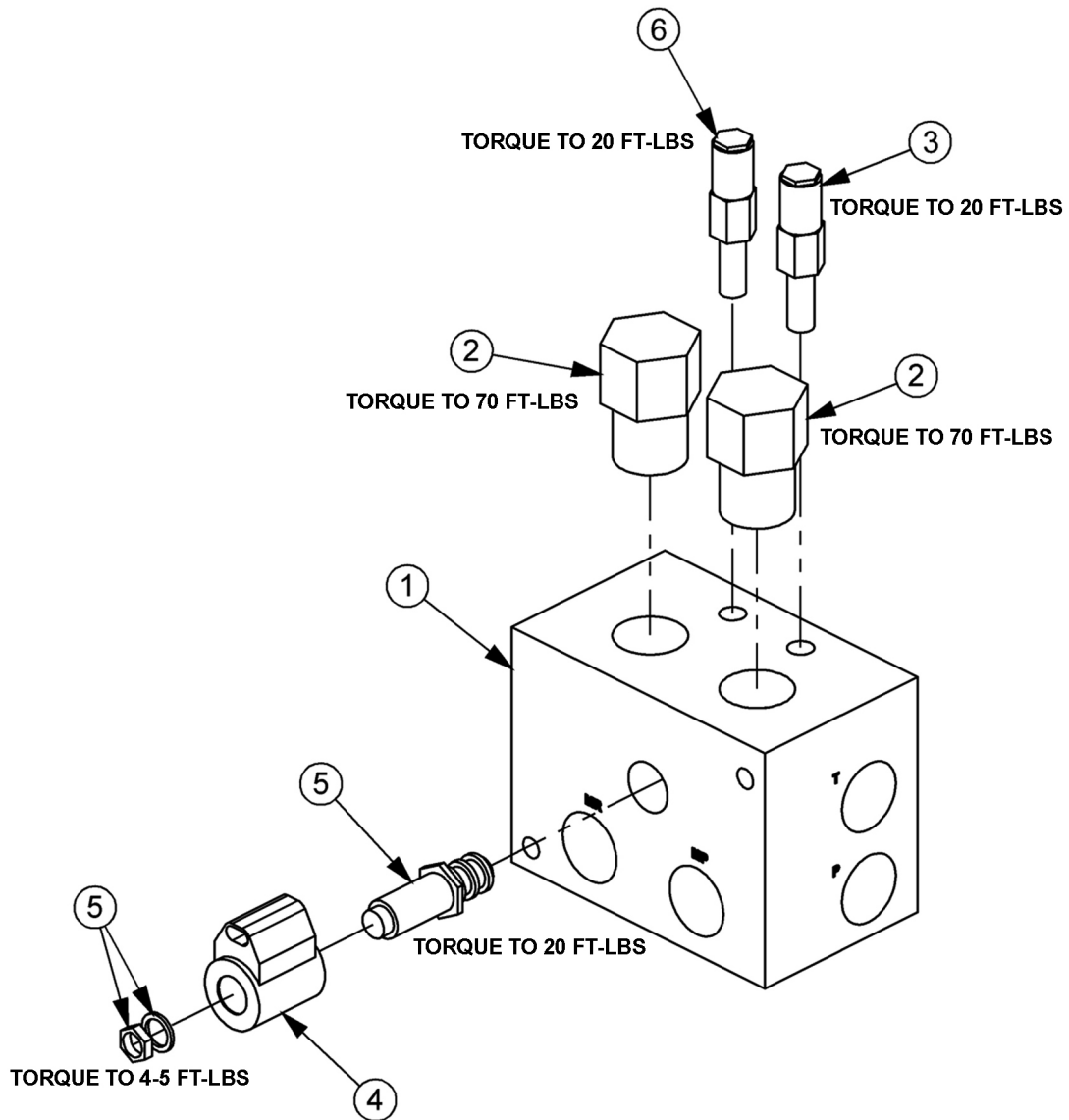

ITEM	PART NO.	QTY.	DESCRIPTION
---	06510083	1	BRAKE VALVE, ASSY
1	34092	1	BRAKE VALVE, BLANK
2	34094	2	LOGIC ELEMENT
3	34095	1	RELIEF VALVE, 3000 PSI
4	06510095	1	METRI PAK COIL
5	34093	1	CARTRIDGE, 2 POSITION, 3 WAY (WITH NUT & WASHER)
6	34091	1	RELIEF VALVE, 2600 PSI
---	34096	2	RELIEF SEAL KIT
----	34097	1	SOLENOID SEAL KIT
---	34098	2	ELEMENT SEAL KIT

COMMON LRS

BRAKE VALVE HYDRAULIC SCHEMATIC

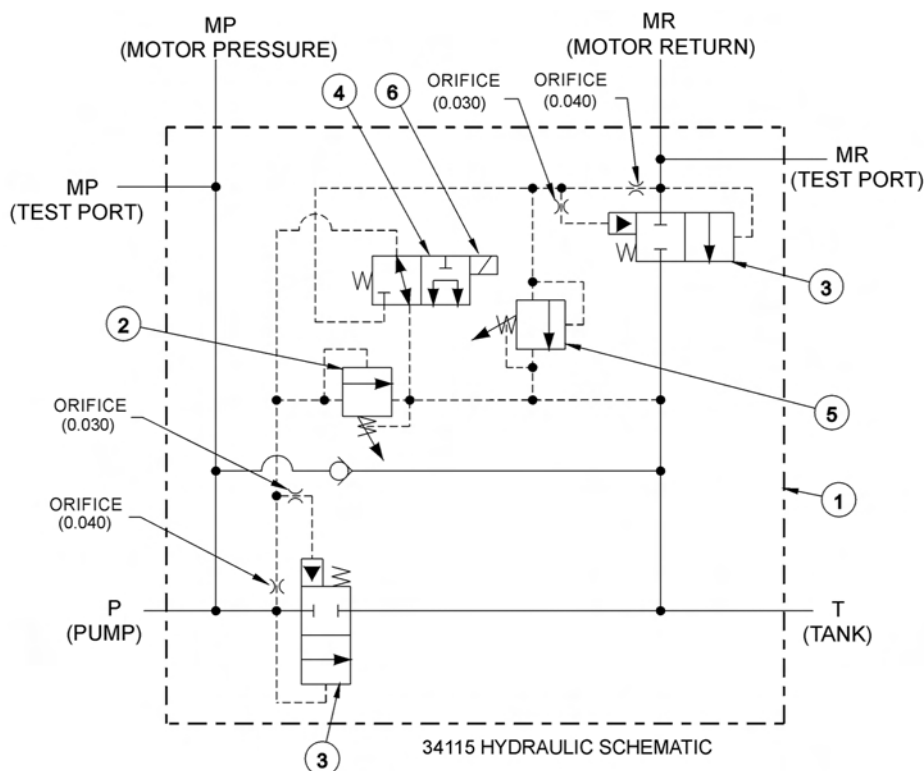

BRAKE VALVE TROUBLESHOOTING

FAILURE MODE:

- MOWER WILL NOT START - system pressure is low (engine not lugging).
- MOWER WILL NOT START - system pressure is high (engine lugging). "MR" port will be high pressure.
- MOWER WILL NOT ROTATE AT FULL SPEED - limited power.
- MOWER BLADE WILL NOT STOP - blade will not stop in proper time.

CHECK STEPS

- 1 thru 6
- 7
- 3 thru 5
- 7 thru 9

CORRECTIVE STEPS:

1. Check for voltage at solenoid (item 6), voltage must be between 10.2 volts and 13.8 volts.
2. Remove, inspect solenoid and cartridge (items 4, 6) for wear or contamination.
3. Remove, inspect logic elements near "P" port (item 3) for wear or contamination.
4. Remove, inspect 3000 psi relief valve (item 2) for wear or contamination.
5. Remove and inspect orifices near "P" port for contamination.
6. Remove "P" port hose and fitting, visually inspect for contamination, check ball for movement.
7. Remove and inspect orifices near "MR" port for contamination.
8. Remove, inspect 2600 psi relief valve (item 5) for wear of contamination.
9. Remove, inspect logic element near "MR" port (item 3) for wear or contamination.

HYDRAULIC TROUBLESHOOTING GUIDE

Hydraulic Troubleshooting guide

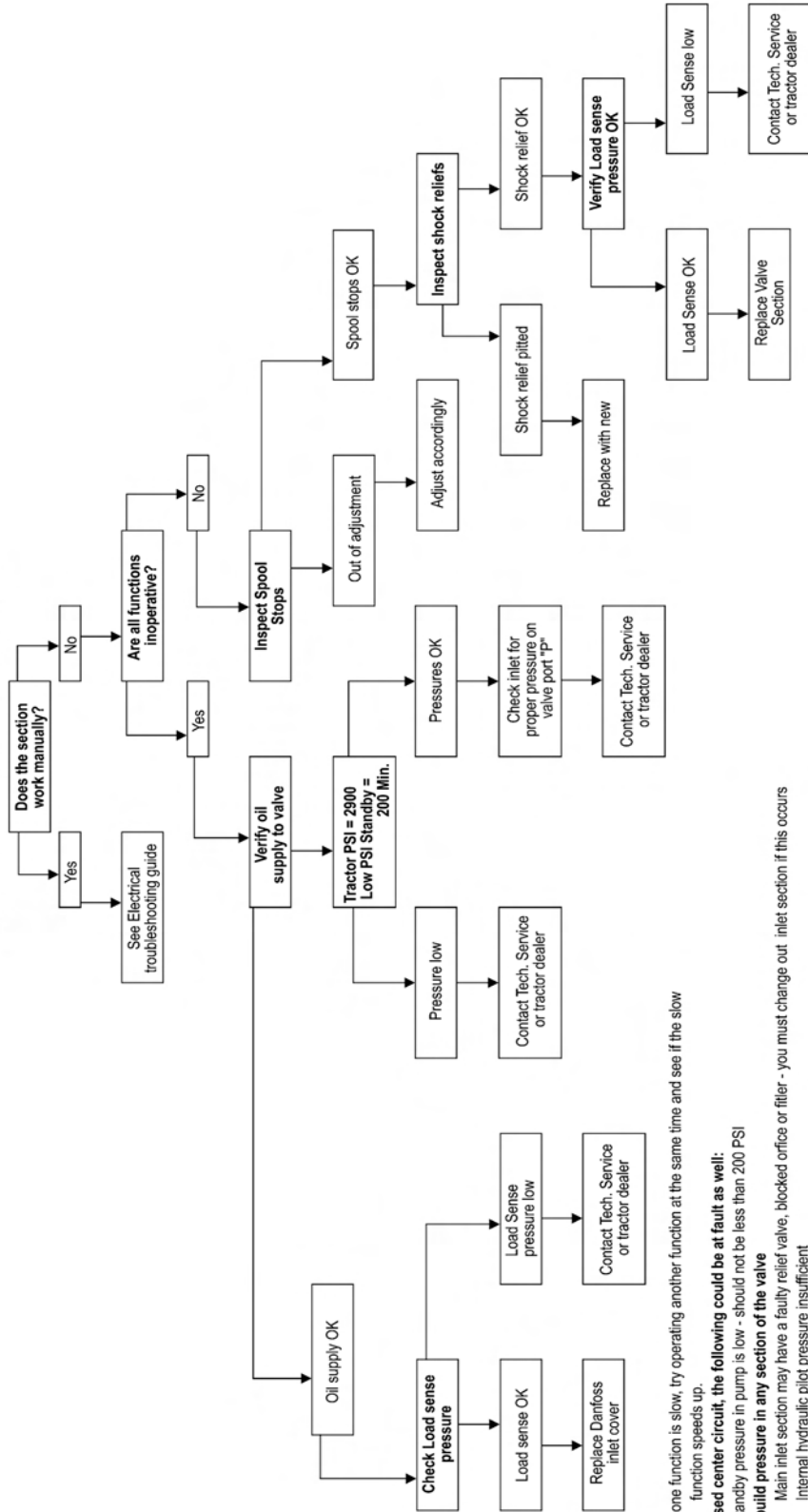

Notes: If one function is slow, try operating another function at the same time and see if the slow function speeds up.

On a closed center circuit, the following could be at fault as well:

Tractor standby pressure in pump is low - should not be less than 200 PSI

Cannot build pressure in any section of the valve

Main inlet section may have a faulty relief valve, blocked orifice or filter - you must change out inlet section if this occurs
Internal hydraulic pilot pressure insufficient

ELECTRICAL TROUBLESHOOTING GUIDE

Joystick Electrical Troubleshooting guide

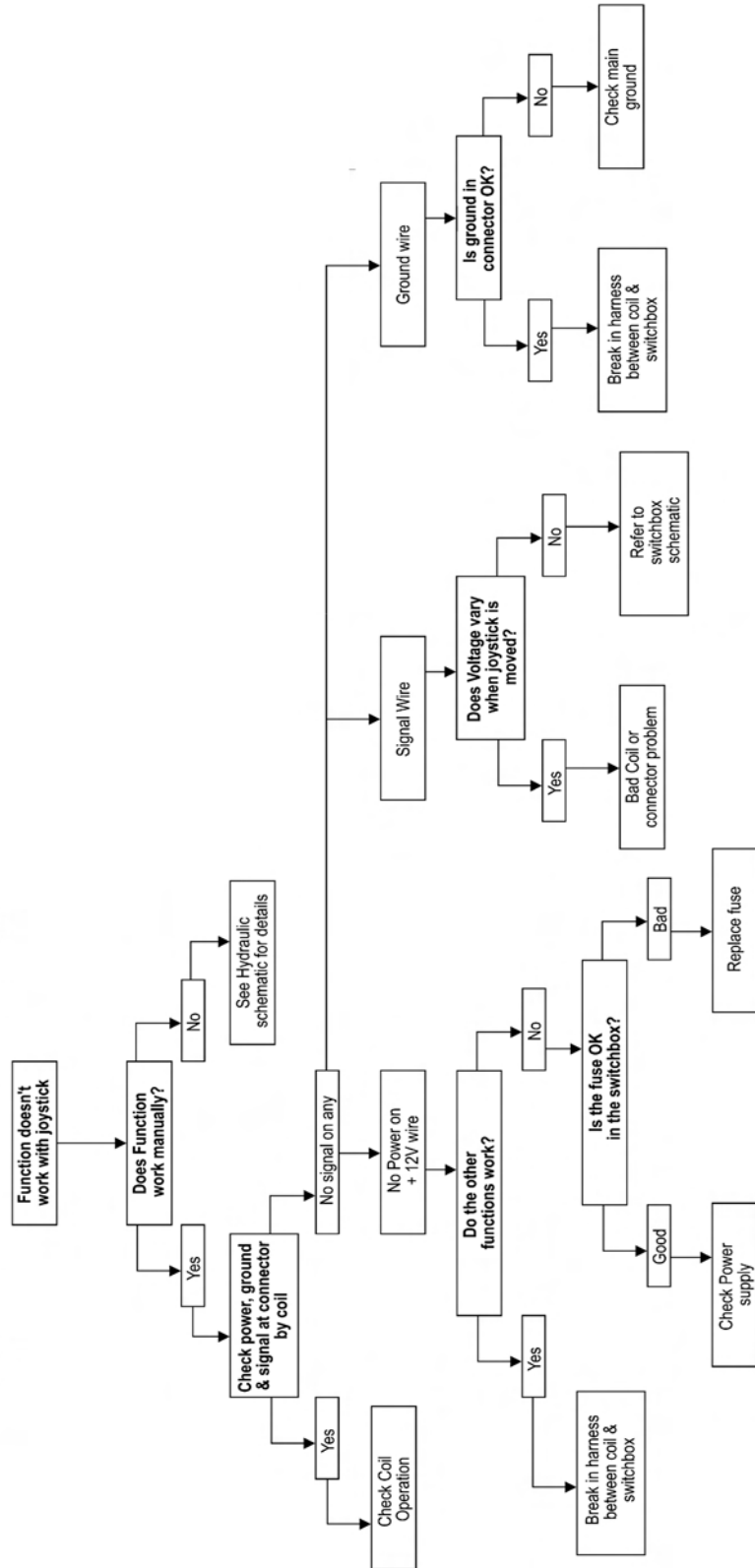

TROUBLESHOOTING

JOYSTICK TROUBLESHOOTING

Boom operation not responding to joystick movement.
Isolate hydraulic vs. electronic symptom.

Turn off electronic master switch (preventing electronic actuator on valve from attempting to hold spool in neutral position). With tractor engine running, operate the valve section with the manual handle. If function operates normally, continue with electronic inspection. If function does not operate normally, continue with hydraulic inspection.

Electronic inspection.

Connect a voltmeter to the cable connector of the valve section that is not operating. This will allow you to measure supply and signal voltage when the joystick is operated.

Main, Secondary, and Swivel Valves – signal voltage should be 50% of supply voltage with joystick in Neutral position, up to 75% of supply voltage in B direction, down to 25% of supply voltage in A direction. Signal voltage should change smoothly with lever movement.

Pin #1 – Supply Voltage Pin #2 – Signal Voltage Pin #gnd – ground

Deck Roll Valve or Float Valve – signal voltage should be 50% of supply voltage with joystick in Neutral position, up to 65% of supply voltage in B direction, down to 35% of supply voltage in A direction. Signal voltage should change smoothly with lever movement. Signal voltage should be approximately 75% of supply voltage when float switch is operated.

Pin #1 – Supply Voltage Pin #2 – Signal Voltage Pin #gnd – ground

Shield Valve or On/Off Valve – Voltage on pin #1 should be equal to supply voltage when switch is operated in A direction. Voltage on pin #2 should be equal to supply voltage when switch is operated in B direction.

Pin #1 – Signal Voltage Pin #2 – Signal Voltage Pin #gnd – ground

If none of the valve will operate with electrical signal, verify that there is oil pressure at the valve inlet. Electrical Valves must have pilot supply oil to move the spools.

Possible electronic problems.

Open circuit (broken wire, bad connection or loose connection in switch box).

Shorted to positive, ground, or other.

Incorrect voltage signal from joystick.

Continued on next sheet

TROUBLESHOOTING - CONTINUED

Hydraulic inspection.

Install 3 pressure gauges, on the valve inlet (use M port, or tee into hose supplying oil from the pump to the inlet), on the workport that is not operating, and on the LS port.

With the spools in Neutral

Gear pump – P should be approximately 200 psi, LS = 0, workport – pressure on cylinder or function.

LS pump – P should equal pump standby pressure, LS = 0, workport – pressure on cylinder or function.

Pressure Comp pump – P should equal pump standby pressure, LS = 0, workport – pressure on cylinder or function.

Gear pump – P should be approximately 200 psi higher than LS, LS should equal workport, workport – pressure on cylinder or function.

LS pump – P should be LS + standby, LS should equal workport, workport – pressure on cylinder or function.

Pressure Comp pump – P should equal pump standby pressure, LS should equal workport, workport – pressure on cylinder or function.

Operate one spool, measure pressures with function at end of travel or stop

Gear pump – P should equal valve relief setting or workport shock valve setting. LS should equal workport. Workport should equal relief setting or workport shock valve setting.

LS pump – P should equal valve relief setting, pump max pressure setting, or workport shock valve setting. LS should equal workport. Workport should equal relief setting, pump max pressure setting, or workport shock valve setting.

Pressure Comp pump – P should equal pump standby pressure, LS should equal workport. Workport should equal pump standby pressure or workport shock valve setting.

Operate more than one spool.

Gear pump – P should approximately 200 psi higher than LS. LS should equal highest workport pressure. Workport – pressure on cylinder or function.

LS pump – P should be LS + standby pressure. LS should equal highest workport pressure. Workport – pressure on cylinder or function.

Pressure Comp pump. P should equal pump standby pressure. LS should equal highest workport pressure. Workport – pressure on cylinder or function.

Possible hydraulic problems.

Cylinder leak.

LS signal leaking to tank before reaching pump LS port.

Hydraulic system or pump not supplying flow to valve.

CLEAN CUTTER HEAD

**CLEAN CUTTER
SECTION**

COMMON LRS

CLEAN CUTTER ASSEMBLY

CAUTION!



Failure to follow the following warnings and instructions may result in serious injury or damage to the equipment or property!

CAUTION!



WARNING: The blade alone weighs approximately 145 lbs. Be sure its weight can be supported before attempting to replace. The use of a lift mechanism will ease replacement.

CLEAN CUTTER BLADE MOUNTING

The CLEAN CUTTER blade was designed for installation onto a standard TRB50 spindle. It is equipped with replaceable carbide tipped teeth. Carbide is very hard, it will chip or break on impact. Handle the saw blade with care. **DO NOT** roll saw on any hard surface or allow it to strike a hard object. Set it down on a piece of belting or wood to avoid damaging carbide tips. Install two temporary(2) threaded studs into (2) opposite holes in the spindle. Align the bolt holes in adapter (part number 33875) with the studs and slide adapter over studs, be sure to index adapter so as the protruding 2 7/8" diameter pilot on the adapter faces outward away from spindle. Then slide the saw blade (part number 33874) over the studs and onto the 2 7/8" diameter pilot of the adapter. **NOTE:** Orient blade for clockwise rotation (blade rotates clockwise when looking down on top of mower deck). Then slide the collar (part number 33876) over the studs with the chamfered edge of collar to the outside, be sure the counterbore bolt holes face outward. Apply Loctite "271" to the threads of the 5/8-18 x 3" UNF Grade 8 bolts (part number 33877), and install lock washers (part number 21992) onto the bolts, then install bolts through collar, blade, and adapter into the spindle. Remove the threaded studs, and replace with bolts and lockwashers. Torque bolts in an alternating pattern to 184 Ft-lbs.

DANGER!



Never work under the Implement, the framework, or any lifted component unless the Implement is securely supported or blocked up to prevent sudden or inadvertent falling which could cause serious injury or even death.



CLEAN CUTTER OPERATION

DANGER!



Never operate the Tractor or Implement until you have read and completely understand this Manual, the Tractor Operator's Manual, and each of the Safety Messages found in the Manual or on the Tractor and Implement. Learn how to stop the tractor engine suddenly in an emergency. Never allow inexperienced or untrained personnel to operate the Tractor and Implement without supervision. Make sure the operator has fully read and understood the manuals prior to operation.



OPERATING INSTRUCTIONS

Inspect clean cutter saw before each use. Re-torque spindle bolts to 204 Ft-lbs. Inspect blade around collar and near the teeth for bends and cracks. Check for loose, broken, chipped, dull or missing teeth. Tighten all loose teeth by hammering and or replacing rivets. If teeth are broken, chipped, or missing or if blade is cracked or becomes bent remove blade and have it repaired at an approved service center. Call Tiger Service Department for replacement parts and service.

The TRB50 Clean Cutter is intended for clean cutting trees and brush up to six (6) inches in diameter maximum. Turn mower "ON" while tractor is running at idle RPM. Then increase tractor speed to 1,950 RPM maximum. Note, this tractor engine speed produces a mower speed of 1,500 RPM. **DO NOT operate the clean cutter mower at speeds in excess of 1,500 RPM.** If saw blade wobbles in excess of two (2) inches while tractor is idling, **STOP**, remove the blade and have it repaired in an approved service center. Call Tiger Service Department for replacement parts and service.

Allow saw to accelerate to maximum speed before moving into foliage. Advance mower head smoothly in foliage. Allow saw to cut through material, do not force or over feed. If saw slows excessively, move the head out of the foliage, and allow the saw to achieve maximum speed. **DO NOT** move up or down or roll mower head while cutting through heavy foliage. **DO NOT** use clean cutter mower on the ground. The saw blade is equipped with carbide tips, which are very hard. Striking rocks, steel, concrete, or other similar debris will break these tips.

Badly worn teeth increase stress to the saw blade and require more horsepower to cut than sharp teeth. Set-up a scheduled maintenance program for the saw before the teeth are dull. The saw will last longer, product a better cut, cut large diameter foliage without binding, and will cost less to operate.

Check adapter and collar every time saw is changed, maintain the .004 inch taper on face (surface against the saw blade) of these two (2) items. Always clean adapter and collar before mounting the blade. If adapter or collars are worn or damaged, they must be replaced.

Familiarize yourself with the machines operation and correct operating safety precautions.

CLEAN CUTTER OPERATION - CONTINUED

WARNING!



Excessive wobble will generate heat in the blade, rapidly accelerating the loss of tension. The overheated blade will then rub against the foliage as it is cutting, again increasing the heat in the blade and intensifying the wobble. The blade may then weaken, crack and eventually fail. **NEVER RUN A BLADE THAT IS CRACKED OF BENT.**

DANGER!



Always keep a careful lookout and use extreme care when working around overhead obstructions. Never allow the Mower head or boom within 10 feet of any power line. When working close to overhead power lines consult your electric company for a safe code of operation.



WARNING!



Do not put hands or feet under mower decks. Blade Contact can result serious injury or even death. Stay away until all motion has stopped and the decks are securely blocked up.



DANGER!



Never operate the Tractor and Mower Unit without an OPS (Operators Protective Structure) or Cab to prevent injury from objects thrown from ground or from overhead trimming. Stop mowing if workers or passersby are within 100 yards.



WARNING!



CAUTION: Never leave the key in the ignition switch. Also personal injury or death can occur from sudden dropping or inadvertent operation of the controls. Make certain the area is clear before lowering or raising the deck.

MAINTENANCE INSTRUCTIONS

Inspect clean cutter saw before each use. Re-torque spindle bolts in an alternating pattern to 204 ft-lbs. Check for loose, broken, chipped, dull or missing teeth. Tighten all loose tooth assemblies by hammer and or replacing rivets. If teeth tips are broken, chipped, or missing, replace tip or replace entire tooth assembly. **NEVER RUN SAW BLADE WITH MISSING TOOTH ASSEMBLY.** If saw blade is cracked, becomes bent or wobbles in excess of two (2) inches while the tractor is idling, **STOP**, remove blade and have it repaired at an approved service center. Call Tiger Service Department for replacement parts and service.

These saw blades are pre-tensioned after the tooth assemblies are riveted in place. This pre-tensioning ensures that the blade runs true and remains true under normal cutting load. Removal of more than one or two complete tooth assemblies at a time may effect the tensioning of the blade. Before cutting always check for wobble while machine is running at idle. If blade wobbles in excess of two (2) inches, **STOP**, remove blade and have it repaired at an approved service center. The teeth tips can be replaced without removing the tooth bodies from the saw blade (see TIP REPLACEMENT PROCEDURE). This method is preferred over the entire removal of tooth assemblies.

Check adapter and collar every time saw is changed, maintain the .004 to .006 inch taper (see figure below) on inside face (surface against saw blade) of these two (2) items. Always clean inside face of adapter and collar before mounting the blade. If adapter or collars are worn, chipped, or damaged, they must be replaced.

Any saw blade (regardless of condition) that has seen regular use should be serviced at least once a year at an approved service center.

Spare saw blades should be stored in a dry environment and transported only on the wooden crates that are supplied with the saw blade.

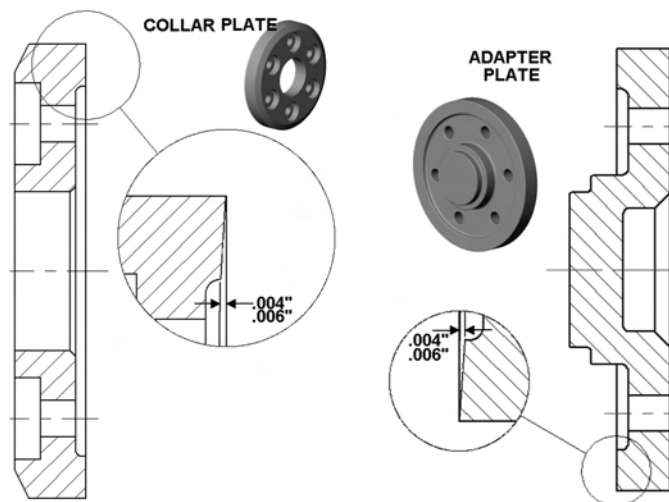

CLEAN CUTTER BLADE AND TEETH PARTS

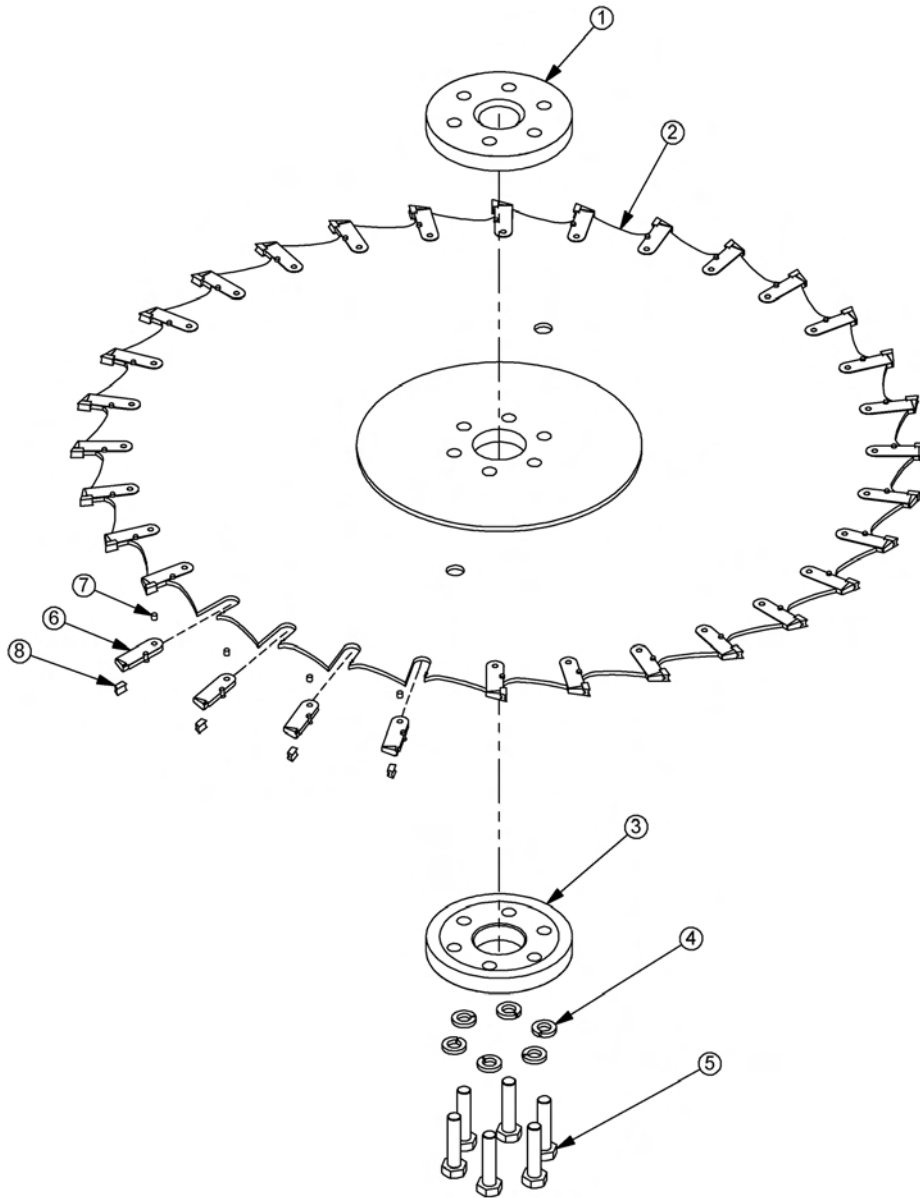

ITEM	PART NO.	QTY.	DESCRIPTION
1	06420024	1	ADAPTER,SAW,TRB50,RNFRCD
2	06520224	1	BLADE, 48" SAW WITH TEETH
3	06420037	1	COLLAR,SAW,TRB50,RNFRCD
4	33764	6	FLATWASHER,5/8,GR 8,SAE
5	06530209	6	CAPSCREW,5/8 X 3 3/4 NF, GR 8
6	06520225	30	TOOTH WITH RIVET, SAW BLADE
7	34703	30	TOOTH RIVET, SAW BLADE
-----	34704	-	RIVET REMOVER TOOL (NOT SHOWN)
8	34702	30	TOOTH TIP, SAW, CARBIDE
-----	34705	-	SHARPENING TOOL (NOT SHOWN)

COMMON LRS

CARBIDE TIP REPLACEMENT

1. Heat face of tip to dull orange, remove tip, then brush tooth body clean of all debris (carbon).
2. Apply acetone to socket rail on tooth body and allow it to evaporate. Dab on soldering paste (black flux) to socket rail of tooth body and slide pre-tinned tip into place.
3. Then heat tip sides and base of socket rail to ensure silver solder flows completely around base of tip. Grasp tip with tweezers and gently twist tip back and forth to ensure complete bonding of silver solder.
4. Discontinue heat, and allow to cool. Then check braze by gently tapping tip with rubber mallet.

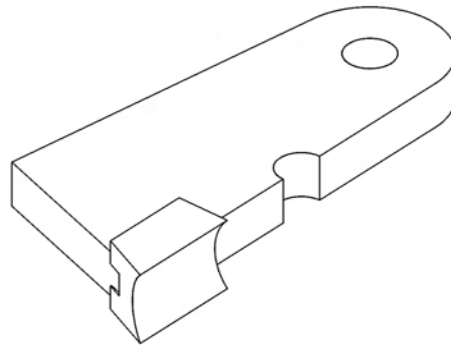

VIEW OF ASSEMBLED TOOTH

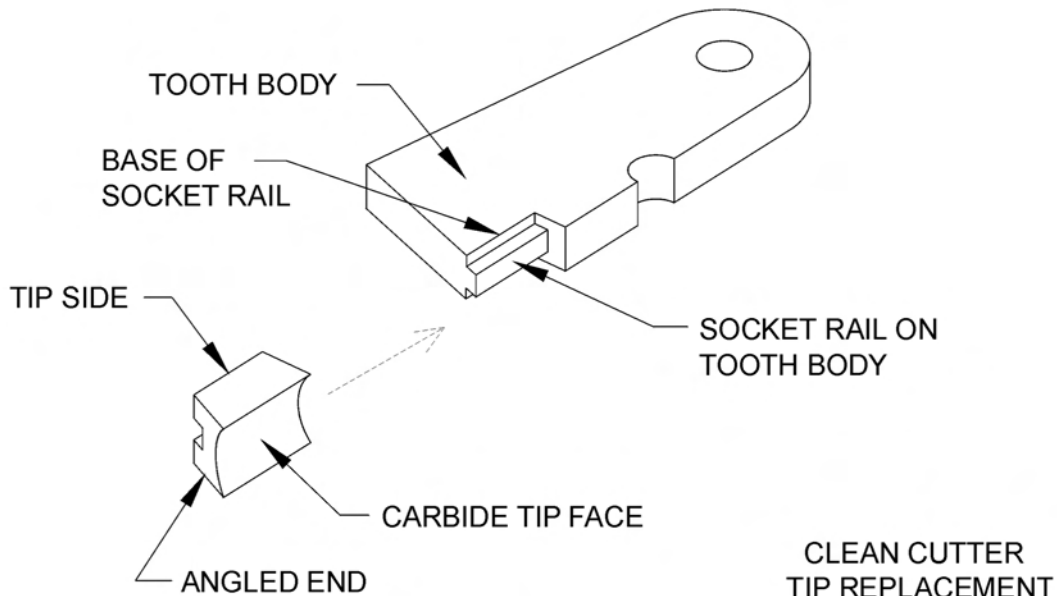

NOTES

**FIRE SUPPRESSION SYSTEM
SECTION**

FIRE SUPPRESSION 3-POINT MOUNT

Continued...

ITEM	PART NO.	QTY.	DESCRIPTION
1	06370137	1	MOUNT,3PNT,FIRE SYS
2	06503108	1	FITTING,1/2"BARB X 1/2"MP
3	35091	6	CLAMP,HOSE,#6
4	06520469	5	HOSE,1/2",BULK (FEET)
5	06503168	2	SWIVEL,1/2"STR,POLY
6	06520359	1	PUMP,LARGE
7	35176	4	U-NUT,1/4"
8	06520367	2	ELBOW,1/2"BARB X 1/2"MP,POLY
9	27329	1	U-BOLT,1/4"
10	06520361	1	FILTER
---	06520351	1	ELEMENT,FILTER
11	06520349	1	FITTING,BARB,HOSE
12	06503169	1	REDUCER,BUSHING (100 & 150 GALLON TANKS ONLY)
13	06520346	1	FITTING,BULKHEAD (50 GALLON TANKS ONLY)
14	21632	4	CAPSCREW,3/8" X 1-1/2",NC
15	21988	4	LOCKWASHER,3/8"
16	06520360	1	HOSE REEL
17	22016	4	FLATWASHER,3/8"
18	21627	4	NYLOCK NUT,3/8",NC
19	21529	2	CAPSCREW,1/4" X 3/4",NC
20	06510258	1	CLAMP,3/4"
21	22014	1	FLATWASHER,1/4"
22	21986	1	LOCKWASHER,1/4"
23	21525	2	HEX NUT,1/4",NC
24	06370121	1	HOLSTER
25	06430090	1	SLEEVE
26	06520366	1	GUN,FIRE SYS
27	6T3222	1	DECAL
28	21527	1	NYLOCK NUT,1/4",NC
29	06510257	1	CLAMP,3/8"
30	28055	5	WIRE,BLACK,14GA (FEET)
31	24200	5	WIRE,RED,14GA (FEET)
32	22802	5	WIRE WRAP (FEET)
33	PT3905A	1	SWITCH
34	06510256	4	CABLE,14GA,4WIRE (FEET)
35	06510255	1	PLUG,7PIN,TRCTR

COMMON LRS

FIRE SUPPRESSION FRONT MOUNT

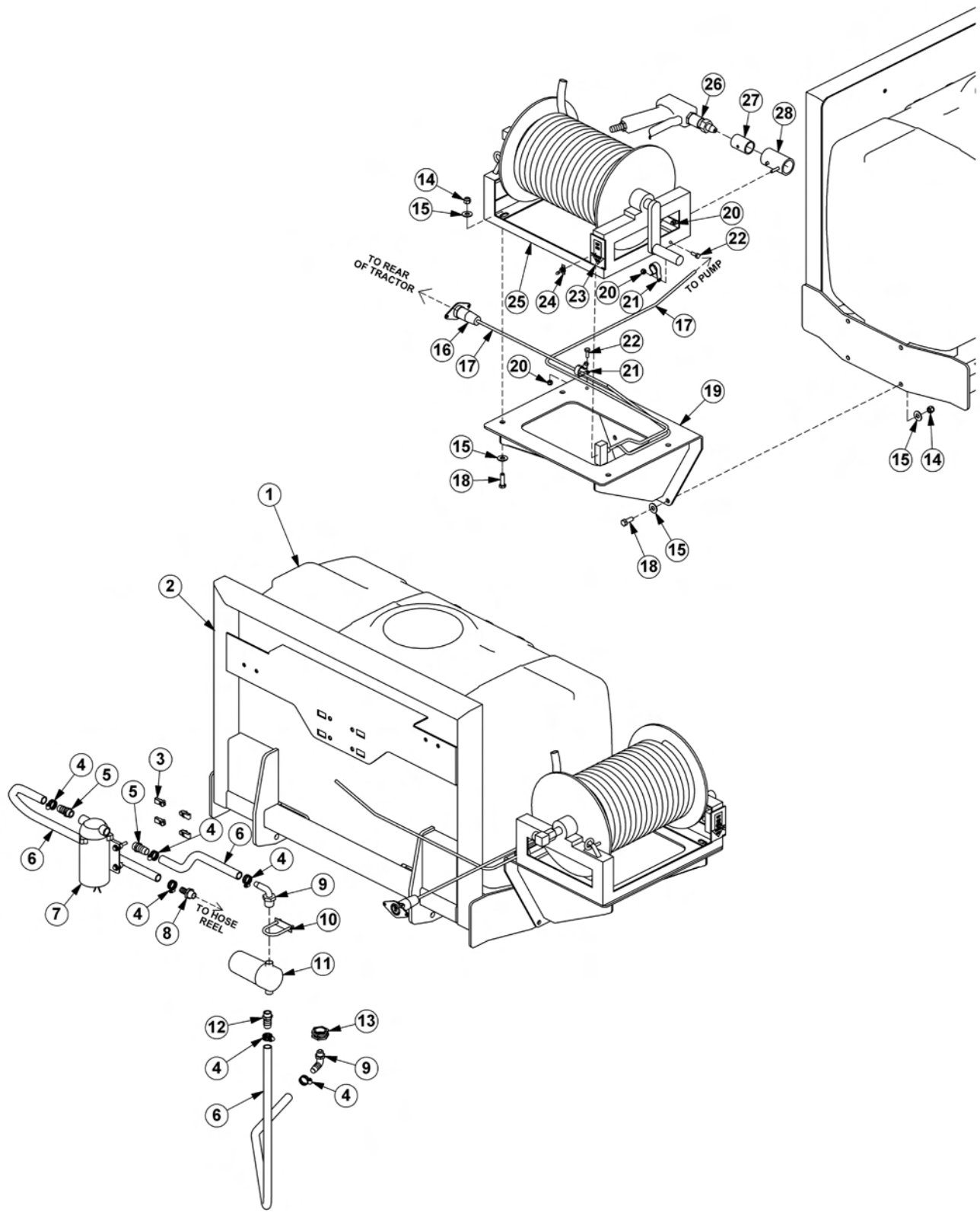

FIRE SUPPRESSION FRONT MOUNT

Continued...

ITEM	PART NO.	QTY.	DESCRIPTION
1	06520342	1	TANK,50 GALLON
2	06370204	1	MNT,TANK,FRNT,50 GALLON
3	35176	4	U-NUT,1/4,3/4 TO CENTER
4	35091	6	CLAMP,HOSE,#6
5	06503168	2	SWIVEL,1/2 STR,POLY
6	06520469	8	HOSE,1/2,SPRAYER
7	06520359	1	PUMP,FIRE KIT
8	06503108	1	FITTING,1/2" BARB X 1/2"MP
9	06520367	2	ELBOW,1/2MPX1/2BARB,POLY
10	27329	1	U-BOLT,1/4X2X1
11	06520361	1	FILTER,FIRE KIT,RAILKUT
---	06520351	1	STRAINER,40 MESH
12	06520349	1	FITTING,BARB,HOSE,WETCUT
13	06520346	1	FITTING,BULKHEAD
14	21627	8	NYLOCK NUT,3/8 NC
15	22016	16	FLATWASHER,3/8,GR8
16	06510255	1	PLUG,7PIN,TRCTR
17	06510256	22	WIRE,14GA,4WIRE (FEET)
18	21631	8	CAPSCREW,3/8X1 1/4, NC,GR8
19	06370207	1	MNT,FIRE SUPPRESSION
20	21527	3	NYLOCK NUT,1/4 NC
21	06510257	2	CLAMP,3/8X1/4,INS
22	21529	2	CAPSCREW,1/4 X 3/4 NC
23	6T3222	1	DECAL,CONTROL,ON-OFF SWITCH
24	PT3905A	1	SWITCH,MOWER
25	06520360	1	HOSE REEL,FIRE KIT,RAILKUT
26	06520366	1	GUN,FIRE KIT,RAILKUT
27	06430090	1	SLEEVE,GUN,FIRE SYS
28	06370121	1	HOLSTER,FIRESYS,RAILKUT

COMMON LRS

FIRE SUPPRESSION SYSTEM ELECTRICAL SCHEMATIC

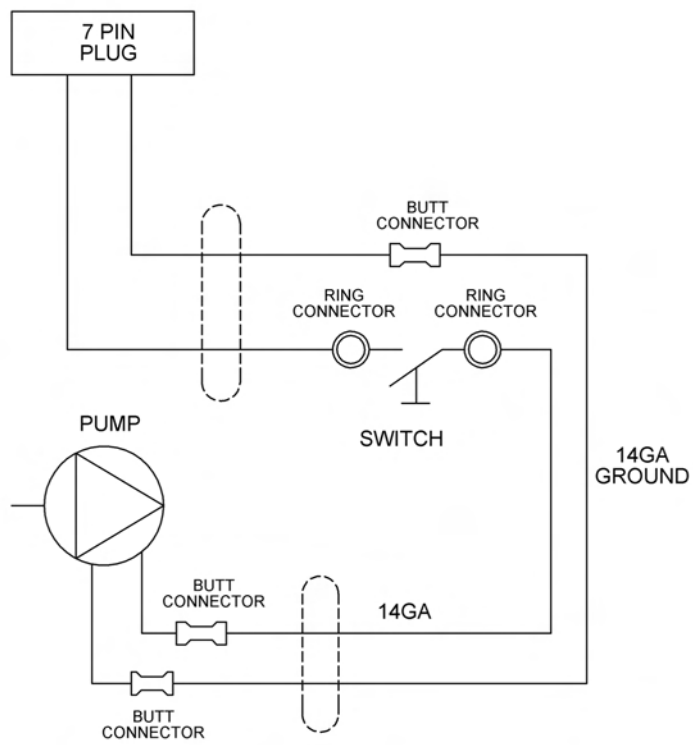

WETCUT

**WETCUT
SECTION**

WETCUT 50 GALLON TANK - 3PNT MOUNT

INSTALL ITEM 2 INTO ITEM 1 FIRST

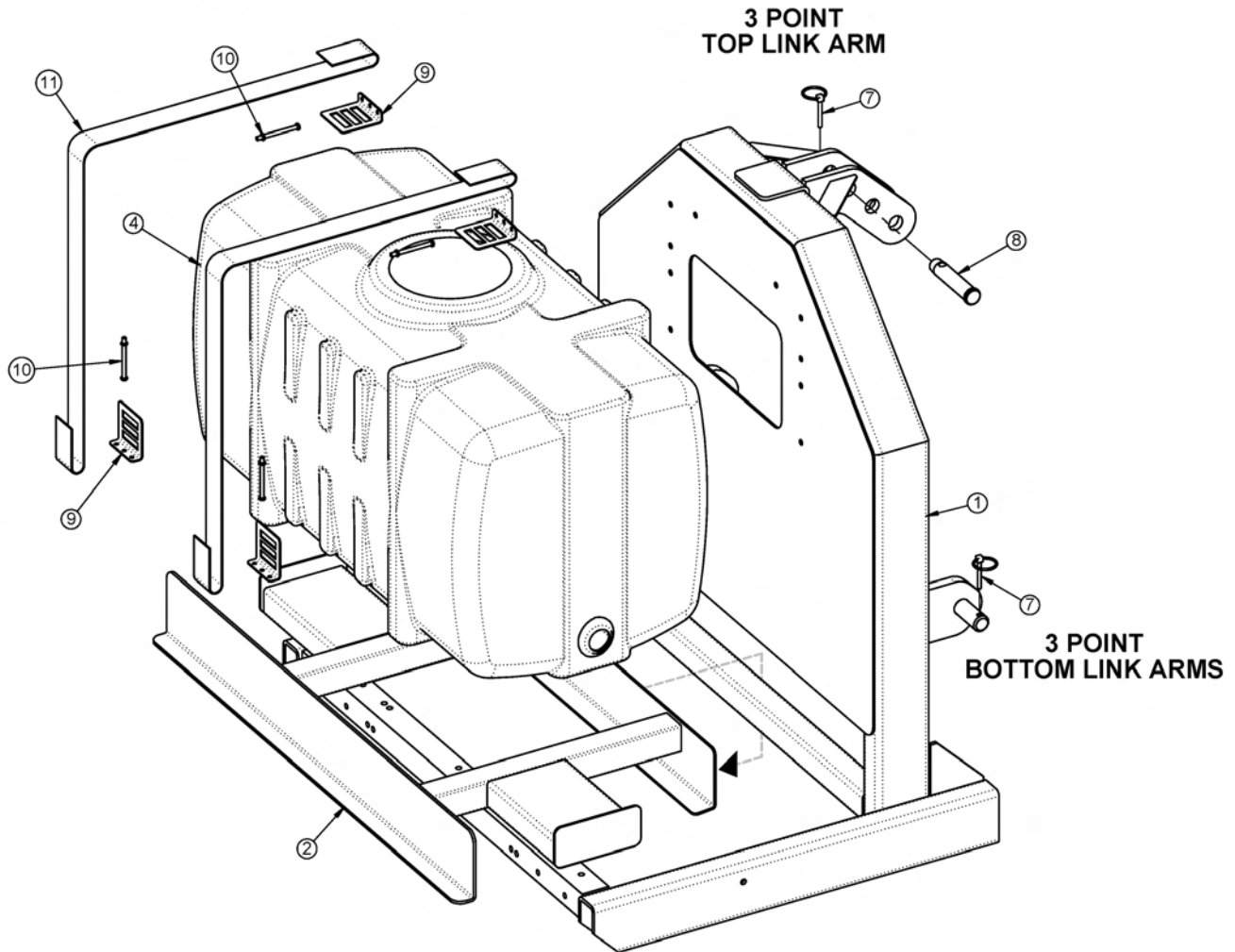

ITEM	PART NO.	QTY.	DESCRIPTION
1	06370128	1	MNT,3PNT,UNI
2	06370136	1	MNT,TANK,50GAL,WETCUT
4	06520342	1	TANK,50GA.,WETCUT
7	RD1032	3	PIN,LYNCH 1/4" X 2"
8	TB1036	1	PIN,SEC BOOM SWIV 1X4-11/16"
9	06520343	4	ANCHOR,STRAP,WETCUT
10	06520344	4	BOLT,STRAP,TANK,WETCUT
11	06520345	2	STRAP,TANK,WETCUT

COMMON LRS

WETCUT 100 OR 150 GALLON TANK - 3PNT MOUNT

INSTALL ITEM 2 INTO ITEM 1 FIRST

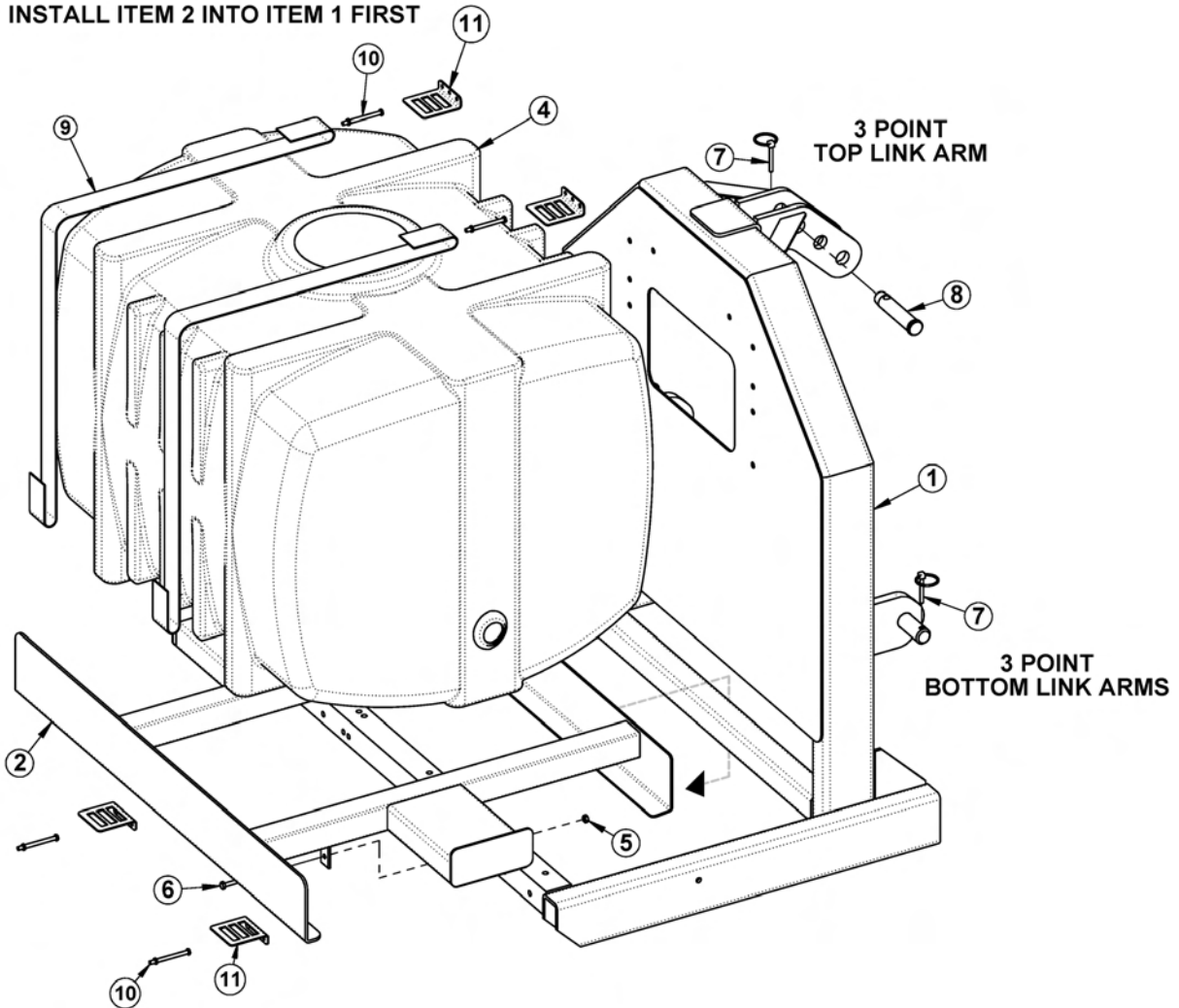

ITEM	PART NO.	QTY.	DESCRIPTION
1	06370128	1	MNT,3PNT,UNI
2	06370138	1	MNT,TANK,100GAL,WETCUT
-----	06370139	-	MNT,TANK,150GAL,WETCUT
4	06520372	1	TANK,100GA.,WETCUT
-----	06520373	-	TANK,150GA.,WETCUT
5	21527	2	HEX NUT,NYLOCK,1/4" NC
6	21530	2	CAPSCREW,1/4" X 1" NC
7	RD1032	3	PIN,LYNCH 1/4" X 2"
8	TB1036	1	PIN,SEC BOOM SWIV 1X4-11/16"
9	06520345	2	STRAP,TANK,WETCUT
10	06520344	4	BOLT,STRAP,TANK,WETCUT
11	06520343	4	ANCHOR,STRAP,WETCUT

COMMON LRS

WETCUT 3PNT PLUMBING - 50IN MOWERS

1. NOTE ORIENTATION ON ITEM ⑨
2. ITEMS ⑰ ⑱ ⑲ ⑳ CUT FROM SUPPLIED 1/2" HOSE
3. ITEMS ㉑ ㉒ ㉓ CUT FROM SUPPLIED 3/8" HOSE

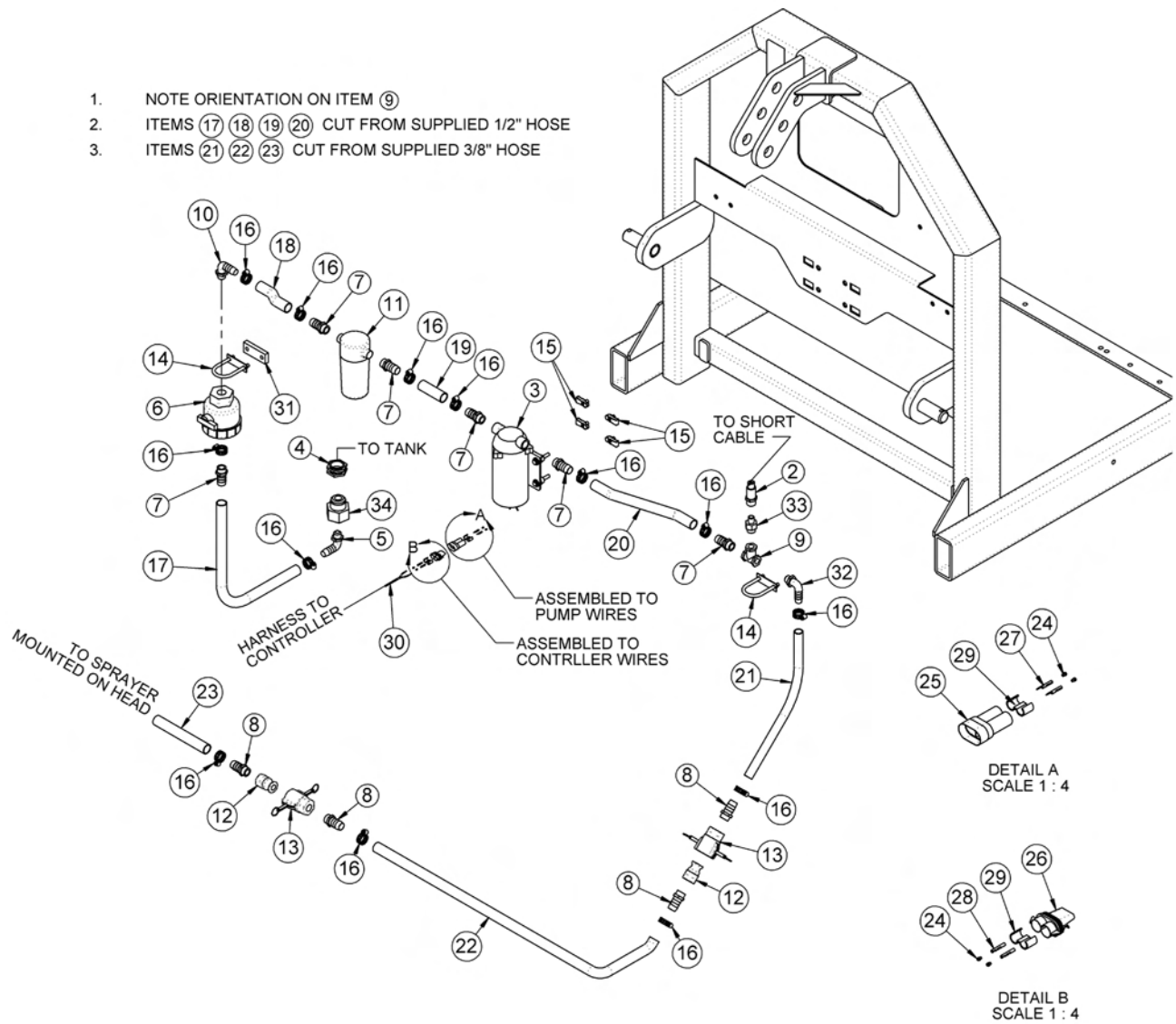

WETCUT 3PNT PLUMBING - 50IN MOWERS

Continued...

ITEM	PART NO.	QTY.	DESCRIPTION
1	06370128	1	MNT,3PNT,UNI
2	06520336	1	CNTRLR,SENSOR,06520333
3	06520341	1	PUMP,WETCUT
4	06520346	1	FITTING,BULKHEAD,WETCUT (50 GALLON TANKS ONLY)
5	06520347	1	FITTING,ELBOW,WETCUT
6	06520348	1	VLV,BALL,WETCUT
7	06520349	6	FITTING,BARB,HOSE,WETCUT
8	06503173	4	FITTING,BARB,1/2X3/8,WETCUT
9	06520353	1	FITTING,TEE,WETCUT
10	06520367	1	ELBOW,1/2X1/2BARB,POLY
11	06520361	1	FILTER,FIRE KIT,RAILKUT
12	06520400	2	QUIK CPLR,MALE,1/2,WETCUT
13	06520401	2	QUIK CPLR,FEM,1/2,WETCUT
14	27329	2	U-BOLT,1/4" X 1" X 2"
15	35176	4	U-NUT,1/4,3/4 TO CENTER
16	35091	13	CLAMP, HOSE #6
17 - 20	06520469	5	1/2" HOSE (FEET)
21 - 23	06520316	-	3/8" HOSE (INCLUDED WITH SPRAYER)
24	06510051	4	SEAL,16-18GA,METPAK
25	06510052	1	CONN.,BODY,MALE,METRIPACK 150
26	06510053	1	CONN.,BODY,FEM,METRIPACK 150
27	06510054	2	TERMINAL,MALE,16/18GA.METPAK
28	06510055	2	TERMINAL,FEM,16/18GA.METPAK
29	06510056	2	TPA
30	06520337	1	INCLUDED WITH CONTROLLER
31	06401133	1	SPACER,Ø.31X1.75X.38
32	06503165	1	ELBOW,1/2X3/8BARB,POLY
33	06520354	1	BUSHING,REDUCER,WETCUT
34	06503169	1	BUSHING,1MPX1/2FP (100 & 150 GALLON TANKS ONLY)

COMMON LRS

WETCUT 3PNT PLUMBING - LARGE MOWERS

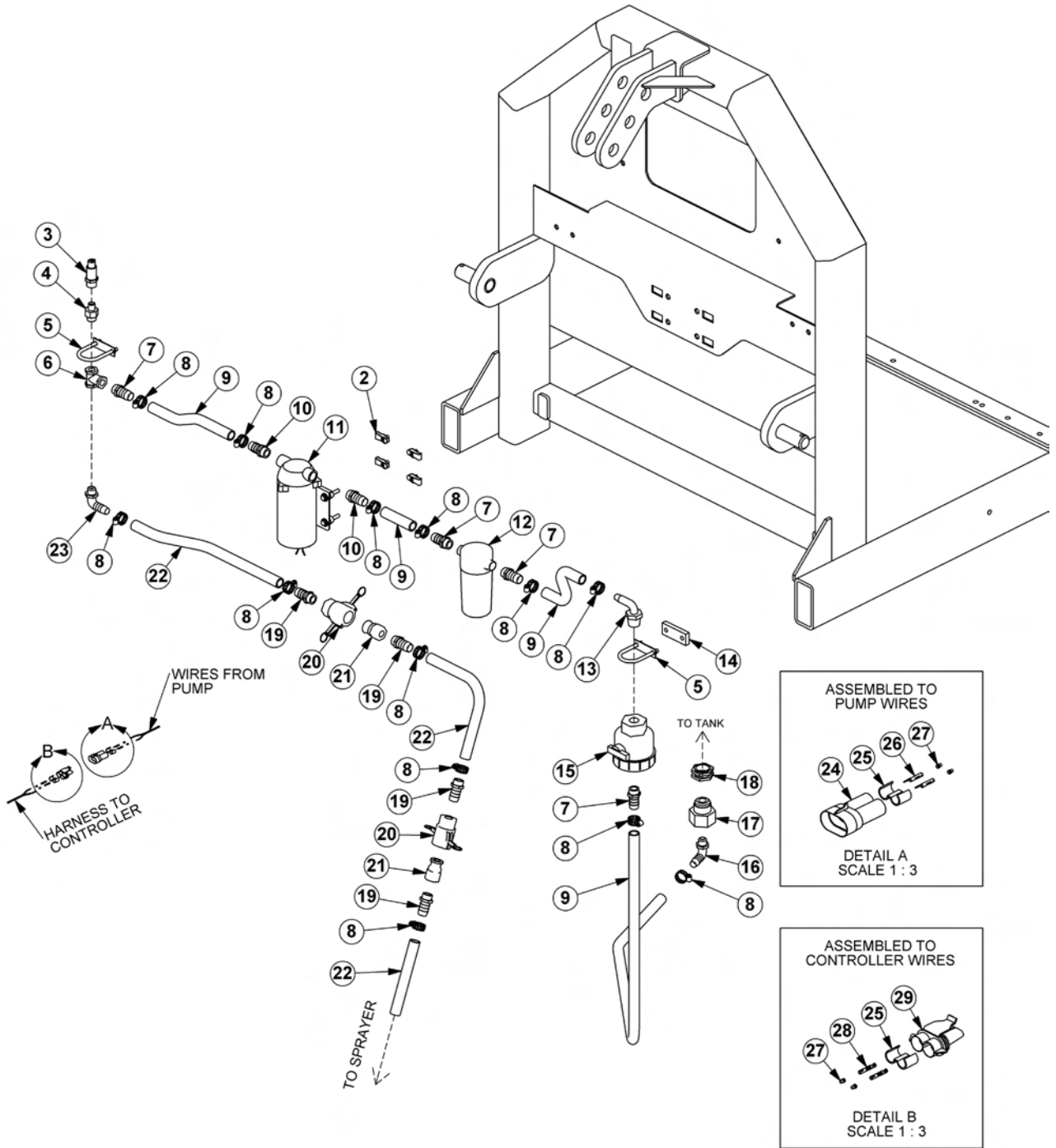

WETCUT 3PNT PLUMBING - LARGE MOWERS

Continued...

ITEM	PART NO.	QTY.	DESCRIPTION
1	06370128	1	MNT,3PNT,UNI
2	35176	4	U-NUT,1/4,3/4 TO CENTER
3	06520336	1	CNTRLR,SENSOR,06520333
4	06520354	1	BUSHING,REDUCER,WETCUT
5	27329	2	U-BOLT,1/4" X 1" X 2"
6	06520353	1	FITTING,TEE,WETCUT
7	06520349	4	FITTING,BARB,HOSE,WETCUT
8	35091	13	CLAMP, HOSE #6
9	06520469	5	1/2" HOSE (FEET)
10	06503168	2	SWIVEL,1/2" STR
11	06520359	1	PUMP,LARGE
12	06520361	1	FILTER,FIRE KIT,RAILKUT
---	06520351	1	STRAINER,40MESH
13	06520367	1	ELBOW,1/2X1/2BARB,POLY
14	06401133	1	SPACER,Ø.31X1.75X.38
15	06520348	1	VLV,BALL,WETCUT
16	06520347	1	FITTING,ELBOW,WETCUT
17	06503169	1	BUSHING,1MPX1/2FP (100 & 150 GALLON TANKS ONLY)
18	06520346	1	FITTING,BULKHEAD,WETCUT (50 GALLON TANKS ONLY)
19	06503173	4	FITTING,BARB,1/2X3/8,WETCUT
20	06520401	2	QUIK CPLR,FEM,1/2,WETCUT
21	06520400	2	QUIK CPLR,MALE,1/2,WETCUT
22	06520316	-	3/8" HOSE (INCLUDED WITH SPRAYER)
23	06503165	1	ELBOW,1/2X3/8BARB,POLY
24	06510052	1	CONN.,BODY,MALE,METRIPACK 150
25	06510056	2	TPA
26	06510054	2	TERMINAL,MALE,16/18GA.METPAK
27	06510051	4	SEAL,16-18GA,METPAK
28	06510055	2	TERMINAL,FEM,16/18GA.METPAK
29	06510053	1	CONN.,BODY,FEM,METRIPACK 150

COMMON LRS

WETCUT FRONT PLUMBING - 50IN MOWERS

1. NOTE ORIENTATION ON ITEM ⑨
2. ITEMS ⑰ ⑱ ⑲ ⑳ CUT FROM SUPPLIED 1/2" HOSE
3. ITEMS ㉑ ㉒ ㉓ CUT FROM SUPPLIED 3/8" HOSE

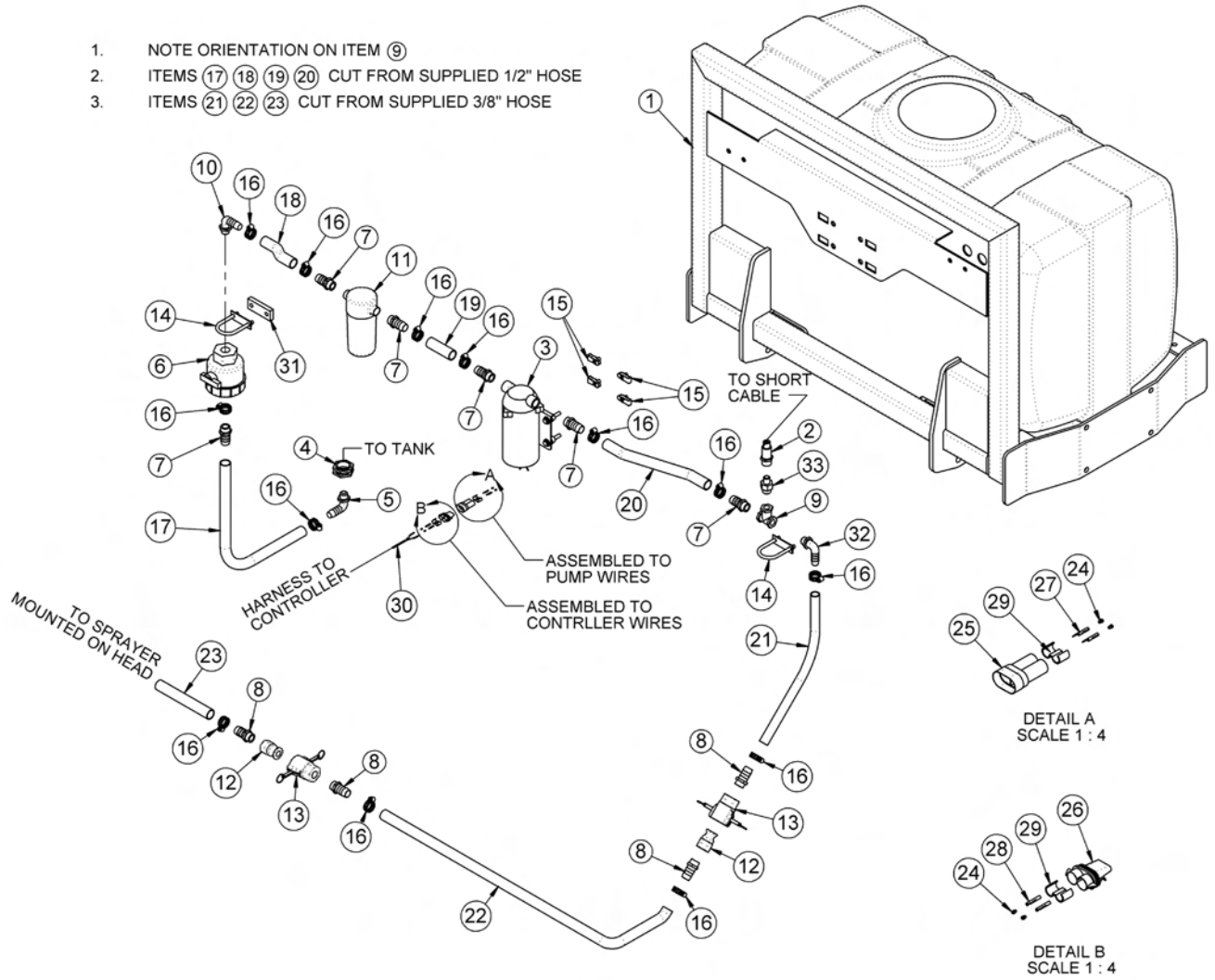

WETCUT FRONT PLUMBING - 50IN MOWERS

Continued...

ITEM	PART NO.	QTY.	DESCRIPTION
1	06370204	1	MNT,FRONT,UNI
2	06520336	1	CNTRLR,SENSOR,06520333
3	06520341	1	PUMP,WETCUT
4	06520346	1	FITTING,BULKHEAD,WETCUT
5	06520347	1	FITTING,ELBOW,WETCUT
6	06520348	1	VLV,BALL,WETCUT
7	06520349	6	FITTING,BARB,HOSE,WETCUT
8	06503173	4	FITTING,BARB,1/2X3/8,WETCUT
9	06520353	1	FITTING,TEE,WETCUT
10	06520367	1	ELBOW,1/2X1/2BARB,POLY
11	06520361	1	FILTER,FIRE KIT,RAILKUT
---	06520351	1	STRAINER,40MESH
12	06520400	2	QUIK CPLR,MALE,1/2,WETCUT
13	06520401	2	QUIK CPLR,FEM,1/2,WETCUT
14	27329	2	U-BOLT,1/4" X 1" X 2"
15	35176	4	U-NUT,1/4,3/4 TO CENTER
16	35091	13	CLAMP, HOSE #6
17 - 20	06520469	5	1/2" HOSE (FEET)
21 - 23	06520316	-	3/8" HOSE (INCLUDED WITH SPRAYER)
24	06510051	4	SEAL,16-18GA,METPAK
25	06510052	1	CONN.,BODY,MALE,METRIPACK 150
26	06510053	1	CONN.,BODY,FEM,METRIPACK 150
27	06510054	2	TERMINAL,MALE,16/18GA.METPAK
28	06510055	2	TERMINAL,FEM,16/18GA.METPAK
29	06510056	2	TPA
30	06520337	1	INCLUDED WITH CONTROLLER
31	06401133	1	SPACER,Ø.31X1.75X.38
32	06503165	1	ELBOW,1/2X3/8BARB,POLY
33	06520354	1	BUSHING,REDUCER,WETCUT

COMMON LRS

WETCUT FRONT PLUMBING - LARGE MOWERS

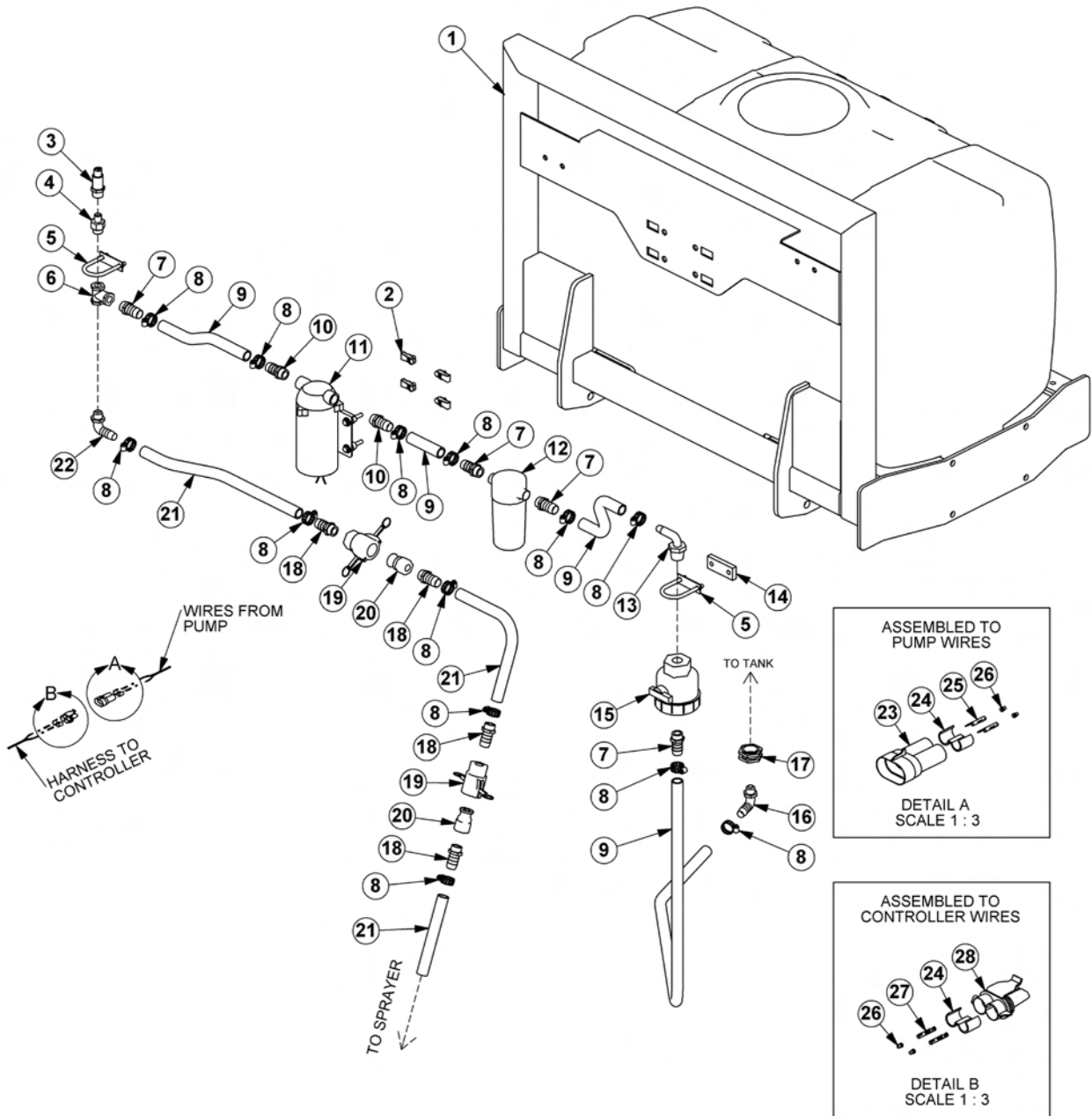

WETCUT FRONT PLUMBING - LARGE MOWERS

Continued...

ITEM	PART NO.	QTY.	DESCRIPTION
1	06370204	1	MNT,FRONT,UNIV
2	35176	4	U-NUT,1/4,3/4 TO CENTER
3	06520336	1	CNTRLR,SENSOR,06520333
4	06520354	1	BUSHING,REDUCER,WETCUT
5	27329	2	U-BOLT,1/4" X 1" X 2"
6	06520353	1	FITTING,TEE,WETCUT
7	06520349	4	FITTING,BARB,HOSE,WETCUT
8	35091	13	CLAMP, HOSE #6
9	06520469	5	1/2" HOSE (FEET)
10	06503168	2	SWIVEL,1/2" STR
11	06520359	1	PUMP,LARGE
12	06520361	1	FILTER,FIRE KIT,RAILKUT
---	06520351	1	STRAINER,40MESH
13	06520367	1	ELBOW,1/2X1/2BARB,POLY
14	06401133	1	SPACER,Ø.31X1.75X.38
15	06520348	1	VLV,BALL,WETCUT
16	06520347	1	FITTING,ELBOW,WETCUT
17	06520346	1	FITTING,BULKHEAD,WETCUT
18	06503173	4	FITTING,BARB,1/2X3/8,WETCUT
19	06520401	2	QUIK CPLR,FEM,1/2,WETCUT
20	06520400	2	QUIK CPLR,MALE,1/2,WETCUT
21	06520316	-	3/8" HOSE (INCLUDED WITH SPRAYER)
22	06503165	1	ELBOW,1/2X3/8BARB,POLY
23	06510052	1	CONN.,BODY,MALE,METRIPACK 150
24	06510056	2	TPA
25	06510054	2	TERMINAL,MALE,16/18GA.METPAK
26	06510051	4	SEAL,16-18GA,METPAK
27	06510055	2	TERMINAL,FEM,16/18GA.METPAK
28	06510053	1	CONN.,BODY,FEM,METRIPACK 150

COMMON LRS

WETCUT 50IN SPRAYER HEAD ASSEMBLY

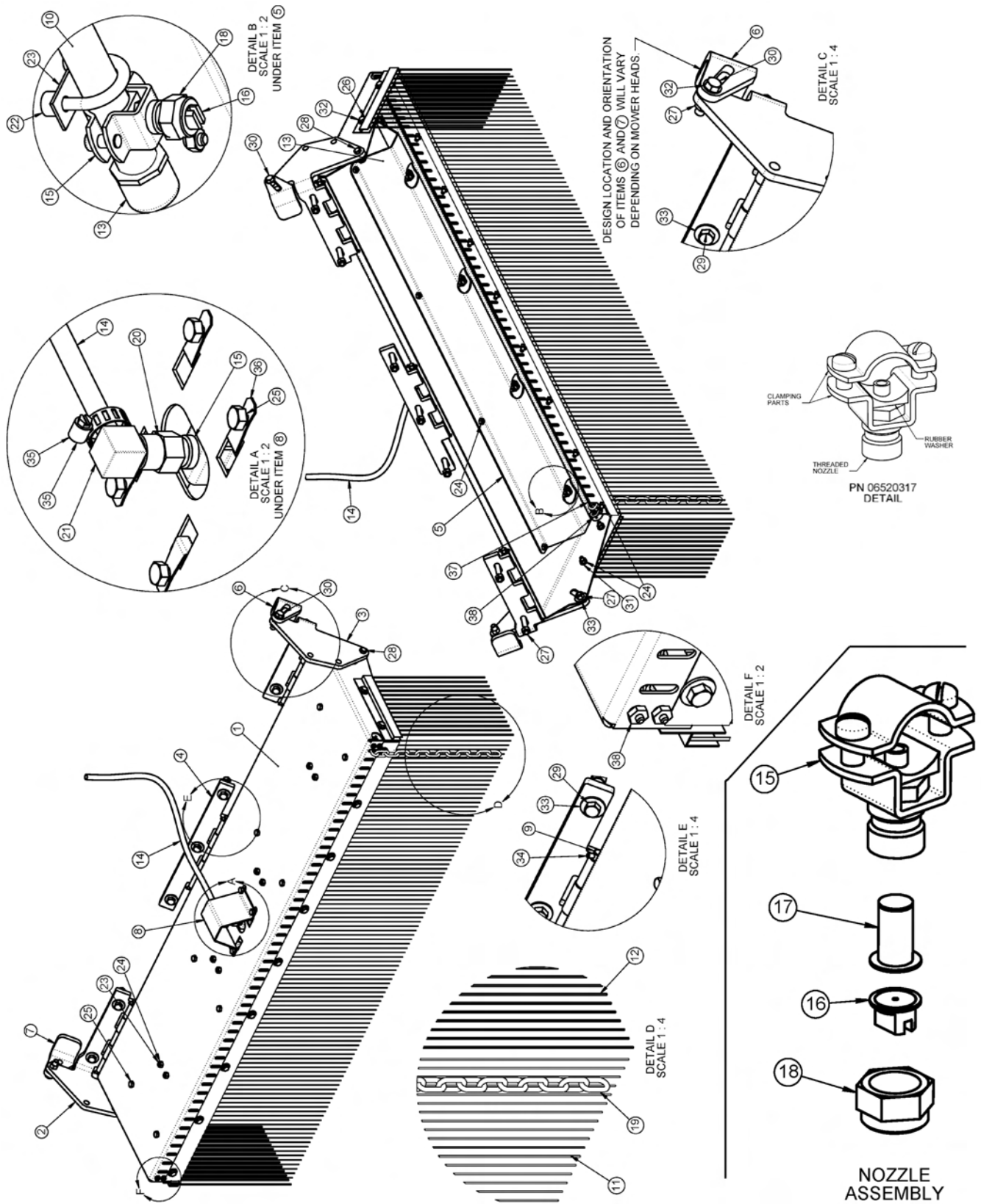

WETCUT 50IN SPRAYER HEAD ASSEMBLY

Continued...

ITEM	PART NO.	QTY.	DESCRIPTION
1	06370105	1	HOOD,SPRAYER
2	06370106	1	HINGE,LH,SPRAYER
3	06370107	1	HINGE,RH,SPRAYER
4	06370108	1	HINGE,CNTR,SPRAYER
5	06410668	1	GUARD,SPRAYER,WETCUT
6	06410753	1	MNT,RH,WET CUT (FLAIL)
---	06410942	1	MNT,RH,WET CUT (ROTARY)
7	06410754	1	MNT,LH,WET CUT (FLAIL)
---	06410943	1	MNT,LH,WET CUT (ROTARY)
8	06410796	1	GUARD,HOSE,WETCUT
9	06420069	3	PIN,HINGE,WET CUT
10	06497003	1	TUBE,LG,SPRAYER
11	06499012	1	SKIRT,ANTI SPRAY,50
12	06499013	2	SKIRT,ANTI SPRAY,7
13	06520314	2	TUBE,CAP,SPRAYER
14	06520316	15	HOSE,SPRAYER (FEET)
15	06520317	5	NOZZLE,SPRAYER
16	06520319	4	TIP,NOZZLE,SPRAYER
17	06520320	4	FILTER,NOZZLE,SPRAYER
18	06520321	4	NUT,NOZZLE,SPRAYER
19	06520322	49	CHAIN,.18" X 1.31" X 13LINKS
20	06520381	1	ADAPTER,1/4"NPT,WETCUT
21	06520382	1	ELBOW,BARB,3/8" X 1/4"NPT
22	06520383	8	SPACER,.50"O.D. X .252"I.D. X .38",NYLON
23	32550	4	U-BOLT,1/4" X 1" X 1" X 1-3/4"
24	21527	29	HEX NUT,NYLOCK,1/4",NC
25	21528	12	CAPSCREW,1/4" X 1/2",NC
26	21529	13	CAPSCREW,1/4" X 3/4",NC
27	21625	11	HEX NUT,3/8",NC
28	21630	2	CAPSCREW,3/8" X 1",NC
29	21634	7	CAPSCREW,3/8" X 2",NC
30	21632	2	CAPSCREW,3/8" X 1-1/2",NC
31	21986	4	LOCKWASHER,1/4"
32	22014	15	FLATWASHER,1/4"
33	22016	9	FLATWASHER,3/8",GR8
34	34698	6	ROLL PIN, PLAIN, 3/16" X 7/8"
35	35091	1	CLAMP,HOSE #6
36	35176	4	U-NUT,1/4",3/4" TO CENTER
37	06520376	5	CABLE,3/16"
38	06537022	2	U-BOLT,CABLE,3/16"

COMMON LRS

WETCUT 60IN SPRAYER HEAD ASSEMBLY

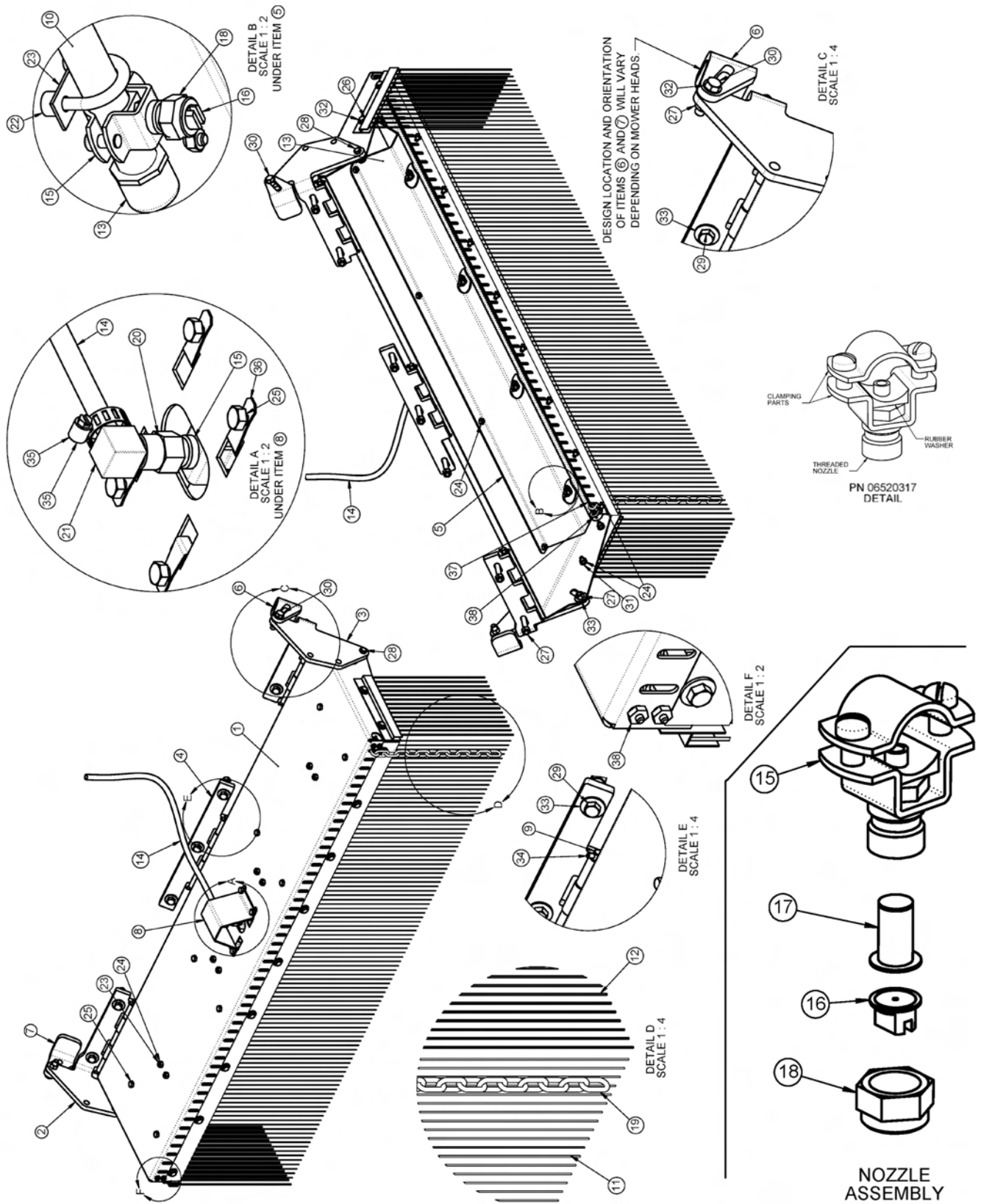

WETCUT 60IN SPRAYER HEAD ASSEMBLY

Continued...

ITEM	PART NO.	QTY.	DESCRIPTION
1	06370210	1	HOOD,SPRAYER
2	06370106	1	HINGE,LH,SPRAYER
3	06370107	1	HINGE,RH,SPRAYER
4	06370108	1	HINGE,CNTR,SPRAYER
5	06411234	1	GUARD,SPRAYER,WETCUT
6	06410753	1	MNT,RH,WET CUT (FLAIL)
---	06410942	1	MNT,RH,WET CUT (ROTARY)
7	06410754	1	MNT,LH,WET CUT (FLAIL)
---	06410943	1	MNT,LH,WET CUT (ROTARY)
8	06410796	1	GUARD,HOSE,WETCUT
9	06420069	3	PIN,HINGE,WET CUT
10	06497009	1	TUBE,LG,SPRAYER
11	06499018	1	SKIRT,ANTI SPRAY,60
12	06499013	2	SKIRT,ANTI SPRAY,7
13	06520314	2	TUBE,CAP,SPRAYER
14	06520316	15	HOSE,SPRAYER (FEET)
15	06520317	6	NOZZLE,SPRAYER
16	06520319	5	TIP,NOZZLE,SPRAYER
17	06520320	5	FILTER,NOZZLE,SPRAYER
18	06520321	5	NUT,NOZZLE,SPRAYER
19	06520322	61	CHAIN,.18" X 1.31" X 13LINKS
20	06520381	1	ADAPTER,1/4"NPT,WETCUT
21	06520382	1	ELBOW,BARB,3/8" X 1/4"NPT
22	06520383	10	SPACER,.50"O.D. X .252" I.D. X .38",NYLON
23	32550	5	U-BOLT,1/4" X 1" X 1" X 1-3/4"
24	21527	33	HEX NUT,NYLOCK,1/4",NC
25	21528	15	CAPSCREW,1/4" X 1/2",NC
26	21529	13	CAPSCREW,1/4" X 3/4",NC
27	21625	13	HEX NUT,3/8",NC
28	21630	2	CAPSCREW,3/8" X 1",NC
29	21634	7	CAPSCREW,3/8" X 2",NC
30	21632	4	CAPSCREW,3/8" X 1-1/2",NC
31	21986	4	LOCKWASHER,1/4"
32	22014	33	FLATWASHER,1/4"
33	22016	11	FLATWASHER,3/8",GR8
34	34698	6	ROLL PIN, PLAIN, 3/16" X 7/8"
35	35091	1	CLAMP,HOSE #6
36	35176	4	U-NUT,1/4",3/4" TO CENTER
37	06520376	6	CABLE,3/16" (FEET)
38	06537022	2	U-BOLT,CABLE,3/16"

COMMON LRS

WETCUT CABLES

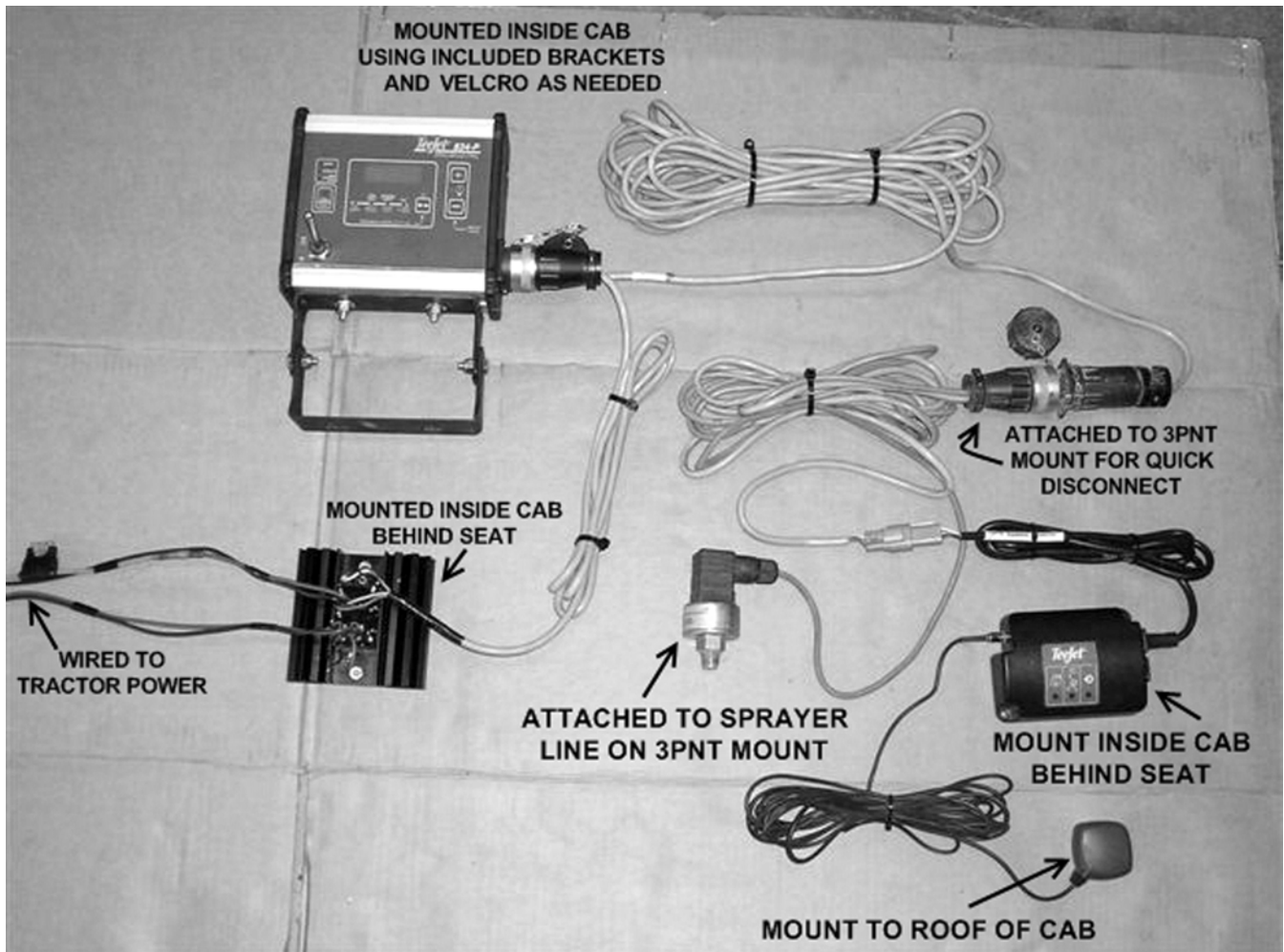



TIGER CORPORATION

WARRANTY INFORMATION

Tiger Corporation, 3301 N. Louise, Sioux Falls, South Dakota, warrants to the original Retail Customer, the new Tiger equipment is free of defects in material and workmanship. Any part of said equipment that in Tiger's adjustment, show evidence of such defects will be repaired or replaced without charge, provided that the failure of part(s) shall have occurred within twelve (12) months from the date of delivery of said equipment to the Retail Customer. Expendable components such as knives, oil, chain sprockets, skid shoes, knife mounting disks and the like are excluded but not limited to this warranty.

The Retail Customer must pay the transportation cost to and from the Tiger Dealer's service shop for warranty service. Warranty service will be performed by the Tiger Dealer from whom the equipment was purchased, in his service shop and during his regularly scheduled days and hours of operation.

All Tiger obligation under this warranty shall be terminated if the equipment is modified or altered in ways not approved in writing by Tiger, if repair parts other than genuine Tiger repair parts have been used, or if the equipment has been subject to misuse, neglect, accident, improper maintenance or improper operation.

Tiger Corporation reserves the right to make improvements in design or changes in specification at any time without incurring any obligation to owners of equipment previously sold.

No agent or person has authority to alter, add to or waive the above warranties which are agreed to be in the only warranties, representations or promises, expressed or implied, as to the quality or performance of the products covered and which do not include any implied warranty of merchantability or fitness. In no event will Tiger be liable for incidental or consequential damages or injuries, including, but not limited to, loss of profits, rental or substitute equipment or other commercial loss.

**THERE ARE NO WARRANTIES WHICH EXTEND
BEYOND THOSE EXPRESSED HEREIN.**

It is the Purchasers obligation to sign the warranty registration form **AFTER** he / she has Read and Understands the Operation and Safety Instructions stated within this manual.

ONE LAST WORD

This manual cannot possibly cover all of the potentially hazardous situations you will encounter. By being familiar, though, with the safety rules, operating and maintenance instructions in this manual you can help prevent accidents. The objective of this manual is to help make you a better operator. Remember, **SAFETY IS YOU!**



Your safety and the safety of those around you depends on **YOU**. Common sense should play a large role in the operation of this machine.

Since we at Tiger Corporation are constantly striving to improve our products, we reserve the right to change specifications or design at any time.