



JOHN DEERE 7X30
COUGAR BOOM

Current as of 01/17/2012



PARTS LISTING WITH
MOUNTING AND OPERATING
INSTRUCTIONS

Tiger Corporation
3301 N. Louise Ave.
Sioux Falls, SD 57107
1-800-843-6849
1-605-336-7900
www.tiger-mowers.com

TO THE OWNER / OPERATOR / DEALER

All implements with moving parts are potentially hazardous. There is no substitute for a cautious, safe-minded operator who recognizes the potential hazards and follows reasonable safety practices. The manufacturer has designed this implement to be used with all its safety equipment properly attached to minimize the chance of accidents.

BEFORE YOU START!! Read the safety messages on the implement and shown in this manual. Observe the rules of safety and use common sense!

READ AND UNDERSTAND THIS MANUAL! Non-English speaking operators will need to GET THE MANUAL TRANSLATED as needed!



DANGER

FAILING TO FOLLOW SAFETY MESSAGES AND OPERATING INSTRUCTIONS CAN CAUSE SERIOUS BODILY INJURY OR EVEN DEATH TO OPERATOR AND OTHERS IN THE AREA.



1. Study and understand Operator's Manuals, Safety Decals, and Instructional Decals for tractor and implement to prevent misuse, abuse, and accidents. Practice before operating in a confined area or near passersby.

● Learn how to stop engine suddenly in an emergency. Be alert for passersby and especially children

2. Allow no children on or near folding mower or tractor. Allow no riders on tractor or implement. Falling off may cause serious injury or death from being run over by tractor or mower or contact with rotating blades.

3. Operate only with tractor having Roll-Over Protective Structure (ROPS) and with seat belt securely fastened to prevent injury and possible death from falling off or tractor overturn.

● Personal Protective Equipment such as Hard Hat, Safety Glasses, Safety Shoes, & Ear Plugs are recommended.

4. Block up or support raised machine and all lifted components securely before putting hands or feet under or working underneath any lifted component to prevent crushing injury or death from sudden dropping or inadvertent operation of controls. Make certain area is clear before lowering or folding

5. Before transporting, put Lift Lever in detent or full-lift position. Install Transport Safety Devices securely on folding mowers. Put Booms securely in Transport Rest.

● Folding and Boom Mowers have raised center of gravity. Slow down when turning and on hillsides.

6. Make certain that SMV sign, warning lights, and reflectors are clearly visible. Follow local traffic codes.

7. Never operate with Cutting Head or Folding Section raised if passersby, bystanders, or traffic are in the area to reduce possibility of injury or death from objects thrown by Blades under Guards or mower structure.

8. Before dismounting, secure implement in transport position or lower to ground.

● Put tractor in park or set brake, disengage PTO, stop engine, remove key, and wait until noise of rotation has ceased to prevent crushing by entanglement in rotating parts which could cause injury or death.

● Never mount or dismount a moving vehicle. Crushing from rollover may cause serious injury or death.



02967827

Warranty Information: Read and understand the complete Warranty Statement found in this manual. Fill out the Warranty Registration form in full and return it within 90 days. Make certain the Serial Number of the machine is recorded on the Warranty Card, and form that you retain.

FORWARD

This manual contains information about many features of the Tiger mowing and roadside maintenance equipment. Some of these include: Safety precautions, Assembly instructions, Operations, Maintenance and Parts. This manual will also assist you in the proper break-in, daily care, and troubleshooting of your new mower.

We recommend that you read carefully the entire manual before operating the unit. Also, time spent in becoming fully acquainted with its performance features, adjustments, and maintenance schedules will be repaid in a long and satisfactory life of the equipment.

Troubleshooting - Please, before you call, help us to help you!

Please look at the equipment to observe what is happening, then:

- Classify the problem
 - Hydraulic, electrical or mechanical - Read the trouble shooting section
 - Tractor or Truck chassis - Contact vehicle dealer

- If unable to correct the problem yourself, contact your local Tiger Dealer after gathering:
 - Machine model _____
 - Serial number _____
 - Dealer name _____
 - Detailed information about the problem including results of troubleshooting

Attention Owner / Operator / Dealer It is your obligation to read, and understand, the warranty information section located at the back of this manual denoting that the purchaser understands the safety issues relating to this machine and has received and will read a copy of this manual.

If at any time, you have a service problem with your Tiger mower, Contact your local dealer for service and parts needed.

MANUFACTURED BY:

Tiger Corporation

3301 N. Louise Ave.

Sioux Falls, SD 57107

1-800-843-6849

1-605-336-7900

www.tiger-mowers.com

DISTRIBUTED BY:

1-_____-_____-_____

1-_____-_____-_____

JD 7X30 COUGAR FORWARD

TABLE OF CONTENTS

SAFETY _____	1-1
Safety Information_____	1-2
ASSEMBLY / MOUNTING SECTION _____	2-1
OPERATION SECTION _____	3-1
MAINTENANCE SECTION _____	4-1
PARTS SECTION _____	5-1
Parts Ordering Guide_____	5-2
Parts Table of Contents_____	5-3
COMMON SABER SECTION _____	6-1
WARRANTY INFORMATION _____	7-1



1012

This symbol means:

CAUTION – YOUR SAFETY IS AT RISK!

When you see this symbol, read and follow the associated instructions carefully or personal injury or damage may result.

Tiger is a registered trademark.



JD 7X30 COUGAR

SAFETY SECTION

SAFETY

A safe and careful operator is the best operator . Safety is of primary importance to the manufacturer and should be to the owner / operator. Most accidents can be avoided by being aware of your equipment, your surroundings, and observing certain precautions. The first section of this manual includes a list of Safety Messages that, if followed, will help protect the operator and bystanders from injury or death. Read and understand these Safety Messages before assembling, operating or servicing this mower . This equipment should only be operated by those persons who have read the Manual, who are responsible and trained, and who know how to do so safely and responsibly.

The Safety Alert Symbol combined with a Signal Word, as seen below, is used throughout this manual and on decals which are attached to the equipment. The Safety Alert Symbol means: **“ATTENTION! BECOME ALERT! YOUR SAFETY IS INVOLVED!”** The symbol and signal word are intended to warn the owner / operator of impending hazards and the degree of possible injury when operating this equipment.

Practice all usual and customary safe working precautions and above all -- remember safety is up to YOU! Only YOU can prevent serious injury or death from unsafe practices.



This is the Safety Alert Symbol. When you see this symbol on your machine or in these instructions, be alert to the potential for personal injury.

CAUTION!



The lowest level of Safety Message; warns of possible injury. Decals located on the equipment with this signal word are Black and Yellow.

WARNING!



Serious injury or possible death! Decals are Black and Orange.

DANGER!



Imminent death / critical injury. Decals are Red and White.

READ, UNDERSTAND, and FOLLOW the following Safety Messages. Serious injury or death may occur unless care is taken to follow the warnings and instructions stated in the Safety Messages. Always use good common sense to avoid hazards. (SG-2)

SAFETY INSTRUCTIONS



SAFETY

PELIGRO!



Si no lee Ingles, pida ayuda a alguien que si lo lea para que le traduzca las medidas de seguridad. (SG-3)



¡ LEA EL INSTRUCTIVO!

DANGER!



Never operate the Tractor or Implement until you have read and completely understand this Manual, the Tractor Operator's Manual, and each of the Safety Messages found in the Manual or on the Tractor and Implement. Learn how to stop the tractor engine suddenly in an emergency. Never allow inexperienced or untrained personnel to operate the Tractor and Implement without supervision. Make sure the operator has fully read and understood the manuals prior to operation. (SG-4)



WARNING!



Always maintain the safety decals in good readable condition. If the decals are missing, damaged, or unreadable, obtain and install replacement decals immediately. (SG-5)

WARNING!



Make certain that the "Slow Moving Vehicle" (SMV) sign is installed in such a way as to be clearly visible and legible. When transporting the Equipment use the Tractor flashing warning lights and follow all local traffic regulations. (SG-6)



WARNING!



Operate this Equipment only with a Tractor equipped with an approved roll-over-protective system (ROPS). Always wear seat belts. Serious injury or even death could result from falling off the tractor--particularly during a turnover when the operator could be pinned under the ROPS. (SG-7)



WARNING!



Do not modify or alter this Implement. Do not permit anyone to modify or alter this Implement, any of its components or any Implement function. (SG-8)

DANGER!



BEFORE leaving the tractor seat, always engage the brake and/or set the tractor transmission in parking gear, disengage the PTO, stop the engine, remove the key, and wait for all moving parts to stop. Place the tractor shift lever into a low range or parking gear to prevent the tractor from rolling. Never dismount a Tractor that is moving or while the engine is running. Operate the Tractor controls from the tractor seat only. (SG-9)



SAFETY

DANGER!



Never allow children or other persons to ride on the Tractor or Implement. Falling off can result in serious injury or death.

(SG-10)



DANGER!



Never allow children to operate or ride on the Tractor or Implement.

(SG-11)



WARNING!



Do not mount the Tractor while the tractor is moving. Mount the Tractor only when the Tractor and all moving parts are completely stopped.

12)

(SG-



DANGER!



Start tractor only when properly seated in the Tractor seat. Starting a tractor in gear can result in injury or death. Read the Tractor operators manual for proper starting instructions. (SG-13)



DANGER!



Never work under the Implement, the framework, or any lifted component unless the Implement is securely supported or blocked up to prevent sudden or inadvertent falling which could cause serious injury or even death. (SG-14)



DANGER!



Do not operate this Equipment with hydraulic oil leaking. Oil is expensive and its presence could present a hazard. Do not check for leaks with your hand! Use a piece of heavy paper or cardboard. High-pressure oil streams from breaks in the line could penetrate the skin and cause tissue damage including gangrene. If oil does penetrate the skin, have the injury treated immediately by a physician knowledgeable and skilled in this procedure. (SG-15)



SAFETY

WARNING!



The operator and all support personnel should wear hard hats, safety shoes, safety glasses, and proper hearing protection at all times for protection from injury including injury from items thrown by the equipment. (SG-16)

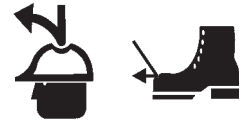

CAUTION!



PROLONGED EXPOSURE TO LOUD NOISE MAY CAUSE PERMANENT HEARING LOSS! Tractors with or without an Implement attached can often be noisy enough to cause permanent hearing loss. We recommend that you always wear hearing protection if the noise in the Operator's position exceeds 80db. Noise over 85db over an extended period of time will cause severe hearing loss. Noise over 90db adjacent to the Operator over an extended period of time will cause permanent or total hearing loss. *Note:* Hearing loss from loud noise [from tractors, chain saws, radios, and other such sources close to the ear] is cumulative over a lifetime without hope of natural recovery. (SG-17)



WARNING!



Transport only at safe speeds. Serious accidents and injuries can result from operating this equipment at unsafe speeds. Understand the Tractor and Implement and how it handles before transporting on streets and highways. Make sure the Tractor steering and brakes are in good condition and operate properly.



Before transporting the Tractor and Implement, determine the safe transport speeds for you and the equipment. Make sure you abide by the following rules:

1. Test the tractor at a slow speed and increase the speed slowly. Apply the Brakes smoothly to determine the stopping characteristics of the Tractor and Implement. As you increase the speed of the Tractor the stopping distance increases. Determine the maximum safe transport speed for you and this Equipment.
2. Test the equipment at a slow speed in turns. Increase the speed through the turn only after you determine that it is safe to operate at a higher speed. Use extreme care and reduce your speed when turning sharply to prevent the tractor and implement from turning over. Determine the maximum safe turning speed for you and this equipment before operating on roads or uneven ground.
3. Only transport the Tractor and Implement at the speeds that you have determined are safe and which allow you to properly control the equipment.

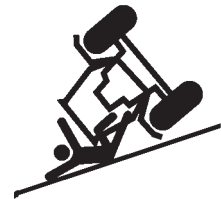

Be aware of the operating conditions. Do not operate the Tractor with weak or faulty brakes. When operating down a hill or on wet or rain slick roads, the braking distance increases: use extreme care and reduce your speed. When operating in traffic always use the Tractor's flashing warning lights and reduce your speed. Be aware of traffic around you and watch out for the other guy. (SG-19)

SAFETY

WARNING!



Never attempt to lubricate, adjust, or remove material from the Implement while it is in motion or while tractor engine is running. Make sure the tractor engine is off before working on the Implement.

(SG-20)

WARNING!



Periodically inspect all moving parts for wear and replace when necessary with authorized service parts. Look for loose fasteners, worn or broken parts, and leaky or loose fittings. Make sure all pins are properly secured. Serious injury may occur from not maintaining this machine in good working order. (SG-21)



WARNING!



Always read carefully and comply fully with the manufacturers instructions when handling oil, solvents, cleansers, and any other chemical agent. (SG-22)



DANGER!



Never run the tractor engine in a closed building or without adequate ventilation. The exhaust fumes can be hazardous to your health.

(SG-23)

DANGER!



KEEP AWAY FROM ROTATING ELEMENTS to prevent entanglement and possible serious injury or death.

(SG-24)



DANGER!



Never allow children to play on or around Tractor or Implement. Children can slip or fall off the Equipment and be injured or killed. Children can cause the Implement to shift or fall crushing themselves or others. (SG-25)

SAFETY

DANGER!



NEVER use drugs or alcohol immediately before or while operating the Tractor and Implement. Drugs and alcohol will affect an operator's alertness and coordination and therefore affect the operator's ability to operate the equipment safely. Before operating the Tractor or Implement, an operator on prescription or over-the-counter medication must consult a medical professional regarding any side effects of the medication that would hinder their ability to operate the Equipment safely. **NEVER** knowingly allow anyone to operate this equipment when their alertness or coordination is impaired. Serious injury or death to the operator or others could result if the operator is under the influence of drugs or alcohol. (SG-27)



DANGER!



Operate the Tractor and/or Implement controls only while properly seated in the Tractor seat with the seat belt securely fastened around you. Inadvertent movement of the Tractor or Implement may cause serious injury or death. (SG-29)

WARNING!



Mow only in conditions where you have clear visibility in daylight or with adequate artificial lighting. Never mow in darkness or foggy conditions where you cannot clearly see at least 100 yards in front and to the sides of the tractor and mower. Make sure that you can clearly see and identify passersby, steep slopes, ditches, drop-offs, overhead obstructions, power lines, debris and foreign objects. If you are unable to clearly see this type of items discontinue mowing. (SGM-1)

DANGER!



There are obvious and hidden potential hazards in the operation of this Mower. **REMEMBER!** This machine is often operated in heavy brush and in heavy weeds. The Blades of this Mower can throw objects if shields are not properly installed and maintained. Serious injury or even death may occur unless care is taken to insure the safety of the operator, bystanders, or passersby in the area. Do not operate this machine with anyone in the immediate area. Stop mowing if anyone is within 100 yards of mower. (SGM-2)



DANGER!



All Safety Shields, Guards and Safety devices including (but not limited to) - the Deflectors, Chain Guards, Steel Guards, Gearbox Shields, PTO integral shields, and Retractable Door Shields should be used and maintained in good working condition. All safety devices should be inspected carefully at least daily for missing or broken components. Missing, broken, or worn items must be replaced at once to reduce the possibility of injury or death from thrown objects, entanglement, or blade contact. (SGM-3)

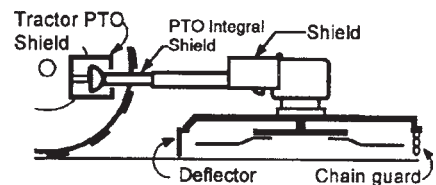

SAFETY

DANGER!



The rotating parts of this machine have been designed and tested for rugged use. However, the blades could fail upon impact with heavy, solid objects such as metal guard rails and concrete structures. Such impact could cause the broken objects to be thrown outward at very high velocities. To reduce the possibility of property damage, serious injury, or even death, never allow the cutting blades to contact such obstacles. (SGM-4)

WARNING!



Extreme care should be taken when operating near loose objects such as gravel, rocks, wire, and other debris. Inspect the area before mowing. Foreign objects should be removed from the site to prevent machine damage and/or bodily injury or even death. Any objects that cannot be removed must be clearly marked and carefully avoided by the operator. Stop mowing immediately if blades strike a foreign object. Repair all damage and make certain rotor or blade carrier is balanced before resuming mowing. (SGM-5)



WARNING!



Many varied objects, such as wire, cable, rope, or chains, can become entangled in the operating parts of the mower head. These items could then swing outside the housing at greater velocities than the blades. Such a situation is extremely hazardous and could result in serious injury or even death. Inspect the cutting area for such objects before mowing. Remove any like object from the site. Never allow the cutting blades to contact such items. (SGM-6)

WARNING!



Mow at the speed that you can safely operate and control the tractor and mower. Safe mowing speed depends on terrain condition and grass type, density, and height of cut. Normal ground speed range is from 0 to 5 mph. Use slow mowing speeds when operating on or near steep slopes, ditches, drop-offs, overhead obstructions, power lines, or when debris and foreign objects are to be avoided. (SGM-7)

WARNING!



Avoid mowing in reverse direction when possible. Check to make sure there are no persons behind the mower and use extreme care when mowing in reverse. Mow only at a slow ground speed where you can safely operate and control the tractor and mower. Never mow an area that you have not inspected and removed debris or foreign material. (SGM-8)

WARNING!



Do not put hands or feet under mower decks. Blade Contact can result serious injury or even death. Stay away until all motion has stopped and the decks are securely blocked up. (SGM-9)



DANGER!



Replace bent or broken blade with new blades. NEVER ATTEMPT TO STRAIGHTEN OR WELD ON BLADES SINCE THIS WILL LIKELY CRACK OR OTHERWISE DAMAGE THE BLADE WITH SUBSEQUENT FAILURE AND POSSIBLE SERIOUS INJURY FROM THROWN BLADES. (SGM-10)

SAFETY

WARNING!



Do not mow with two machines in the same area except with Cab tractors with the windows closed. (SGM-11)

DANGER!



Rotary and Flail Mowers are capable under adverse conditions of throwing objects for great distances (100 yards or more) and causing serious injury or death. Follow safety messages carefully. **STOP MOWING IF PASSERSBY ARE WITHIN 100 YARDS UNLESS:**

- Front and Rear Deflectors are installed and in good, working condition;
- Mower Head is running close to and parallel to the ground without exposed Blades;
- Passersby are outside the existing thrown-object zone;
- All areas have been thoroughly inspected and all foreign material such as rocks, cans, glass, and general debris has been removed.



NOTE: Where there are grass and weeds high enough to hide debris that could be struck by the blades, the area should be: inspected and large debris removed, mowed at an intermediate height, inspected closely with any remaining debris being removed, and mowed again at desired final height. (SBM-1)



DANGER!



Use extreme caution when raising the Mower head. Stop the Blades from turning when the Mower Head is raised and passersby are within 100 yards. Raising the Mower head exposes the Cutting Blades which creates a potentially serious hazard and can cause serious injury by objects thrown from the Blades or by contact with the Blades. (SBM-2)

DANGER!



Be particularly careful in transport. The Mower has raised the center of gravity for the tractor and has increased the possibility of overturn. Turn curves or go up slopes only at low speed and using a gradual turning angle. Slow down on rough or uneven surfaces. (SBM-3)



WARNING!



Never Leave the mower unattended while the head is in the raised position. The mower could fall causing serious injury to anyone who might inadvertently be under the mower. (SBM-4)



WARNING!



The rotating parts of this machine continue to rotate even after the Tractor has been turned off. The operator should remain in his seat for 60 seconds after the brake has been set, the PTO disengaged, the tractor turned off, and all evidence of rotation has ceased. (SBM-5)

“Wait a minute...Save a life!”

SAFETY



Relieve hydraulic pressure prior to doing any maintenance or repair work on the Implement. Place the Mower Head on the ground or securely supported on blocks or stands, disengage the PTO, and turn off the engine. Push and pull the control Levers or Joystick several times to relieve pressure prior to starting any maintenance or repair work. (SBM-6)

DANGER!



Always keep a careful lookout and use extreme care when working around overhead obstructions. Never allow the Mower head or boom within 10 feet of any power line. When working close to overhead power lines consult your electric company for a safe code of operation. (SBM-7)

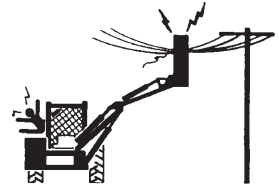

DANGER!



When transporting Boom Mower on a truck or trailer, the height or width may exceed legal limits when the boom is in the transport position. Contact with side or overhead structures or power lines can cause property damage or serious injury or death. If necessary lower boom to reduce height and/or remove mowing head to reduce width to the legal limits. (SBM-8)

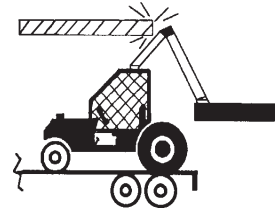

DANGER!



Never operate the Tractor and Mower Unit without an OPS (Operators Protective Structure) or Cab to prevent injury from objects thrown from ground or from overhead trimming. Stop mowing if workers or passersby are within 100 yards. (SBM-9)

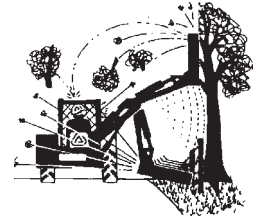

DANGER!



Each Rear Wheel must have a minimum of 1500 pound contact with the surface to prevent lateral instability and possible tip-over which could result in serious bodily injury or even death. Widen the wheel tread and add weights if needed. Refer to the mounting instructions or call Customer Service if you need assistance with Counterweight Procedure. (SBM-11)



DANGER!



Always disconnect the wire leads from the mower pump solenoid before performing service on the Tractor or Mower. Use caution when working on the Tractor or Mower. Tractor engine must be stopped before working on Mower or Tractor. The Mower Blades could inadvertently be turned on without warning and cause immediate dismemberment, injury or death. (SBM-12a)

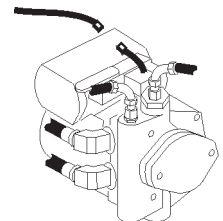

DANGER!



The flail cutter shaft is designed for standard rotation (same rotation as the tractor wheels during forward travel). **Never operate the cutter shaft in the reverse rotation.** Operating this mower in reverse rotation may cause objects to be thrown out the front of the mower head.

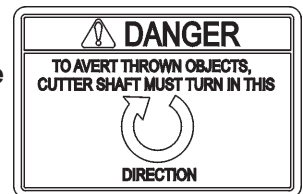

SAFETY

WARNING!



Engine Exhaust, some of its constituents, and certain components contain or emit chemicals known to the state of California to cause cancer and birth or other reproductive harm.

WARNING!



Battery posts, terminals and related accessories contain lead and lead compounds, chemicals known to the state of California to cause cancer and birth or other reproductive harm. **Wash hands after handling!**

Tiger mowers use balanced and matched system components for blade carriers, blades, cutter-shafts, knives, knife hangers, rollers, drive-train components and bearings. These parts are made and tested to Tiger specifications. Non-genuine “will fit” parts do not consistently meet these specifications. The use of “will fit” parts may reduce mower performance, void mower warranties and present a safety hazard. Use genuine Tiger mower parts for economy and safety.

SEE YOUR  DEALER

In addition to the design and configuration of this Implement, including Safety Signs and Safety Equipment, hazard control and accident prevention are dependent upon the awareness, concern, prudence, and proper training of personnel involved in the operation, transport, maintenance, and storage of the machine. Refer also to Safety Messages and operation instruction in each of the appropriate sections of the T ractor and Equipment Manuals. Pay close attention to the Safety Signs affixed to the T ractor and Equipment. (SG-18)

SAFETY

PART NO.
LOCATION

DANGER

FAILING TO FOLLOW SAFETY MESSAGES AND OPERATING INSTRUCTIONS CAN CAUSE SERIOUS BODILY INJURY OR EVEN DEATH TO OPERATOR AND OTHERS IN THE AREA.

<p>1.</p>	<p>2. NO RIDERS, NO CHILDREN OPERATORS</p>	<p>3. USE SAFETY SHOES, HARD HAT, SAFETY GLASSES, SEAT BELTS, & ROPS</p>	<p>4. BLOCK UP SECURELY BEFORE WORKING UNDER.</p>
-----------	--	--	---

1 Study and understand Operator's Manuals, Safety Signs, and Instructional Decals for tractor & flail mower to prevent misuse, abuse, & accidents. Practice before operating mower in a confined area or near passersby.

- Learn how to stop engine suddenly in an emergency. Be alert for passersby and especially children.

2 Allow no children on or near implement or tractor. Allow no riders on tractor or implement. Falling off can cause serious injury or death from being runover by tractor or mower or contact with Flail Mower Blades.

3 Operate only with tractor having Roll-Over Protective Structure (ROPS) and with seatbelt fastened securely and snugly to prevent injury and possible death from falling off or tractor overturn. Personal Protective Equipment such as Hard Hat, Safety Glasses, Safety Shoes, and Ear Plugs are recommended.

4 Block up or support raised machine and all lifted components securely before putting hands or feet under or working underneath any lifted component to prevent crushing injury or death from sudden dropping or inadvertent operation of controls. Make certain that area is clear before lowering or folding.

5 Before transporting, put Lift Lever in detent or full-lift position. Install Transport Safety Devices securely on folding implements. Slow down when turning and on hillsides.

- Install **Restrictor in folding circuit to slow down lowering and unfolding if action is faster than is desirable.

6 Make certain that SMV sign, Warning Lights, and Reflectors are clearly visible. Follow local traffic codes.

7 Never operate with Flail Mower or Folding Section raised if passersby, bystanders or traffic are in the area to reduce possibility of injury or death from objects thrown by Blades under Shields or implement structure.

8 Before dismounting, secure flail mower in transport position or lower to ground.

- Put tractor in park or set brake, disengage PTO, stop engine, remove key, and wait until noise of rotation has ceased to prevent entanglement in rotating parts which may cause injury or death.
- Never mount or dismount a moving vehicle. Crushing from runover may cause injury or death.

<p>5. TRANSPORT SAFELY, LOCK UP.</p>	<p>6. USE SMV, LIGHTS, & REFLECTORS.</p>	<p>7. DONOT OPERATE WITH MOWER OR WING RAISED.</p>	<p>8. DO NOT MOUNT OR DISMOUNT WHILE MOVING.</p>
--------------------------------------	--	--	--

002369
HYDRAULIC TANK

PELIGRO

Si No Lee Ingles, Pida Ayuda a Alguien Que Si Lo Lea. Para Que le Traduzca las Medidas de Seguridad.

LEA EL INSTRUCTIVO

00725746

00725746
INSIDE OF CAB

DANGER

THROWN OBJECTS

CUTTING BLADES

KEEP AWAY - ROTATING BLADES

BEING HIT BY THROWN OBJECTS OR CONTACTING ROTATING BLADES CAN CAUSE INJURY OR DEATH.

- Stop mowing if passersby enter the area of thrown objects (See Operator's Manual).
- Use special care if Mower Head or Wing is raised off the ground. (See Manual).
- Operate only if all Guards-Deflectors are in place and in good condition.

00769737

00769737
MOWER DECK

SAFETY



PART NO.
LOCATION

00758194
MOWER DECK



02962764
MAIN BOOM, SECONDARY BOOM, MAIN FRAME



02962765
MAIN FRAME

02965262
HYDRAULIC TANK

SAFETY

DANGER

CUTTING BLADES



THROWN OBJECTS



KEEP AWAY - ROTATING BLADES

BEING HIT BY THROWN OBJECTS OR CONTACTING ROTATING BLADES CAN CAUSE INJURY OR DEATH

- Stop mowing if passersby enter the area of thrown objects. (See Operator's Manual)
- Use special care when Flail or Wing is raised off the ground. (See Oper. Manual)
- Operate only if all Guards-Deflectors are in place and in good condition.

PART NO.
LOCATION

02967668
MOWER DECK

02971123
HYDRAULIC TANK

03200285
OUTSIDE OF CAB

22645
INSIDE OF CAB

22839
MOWER DECK

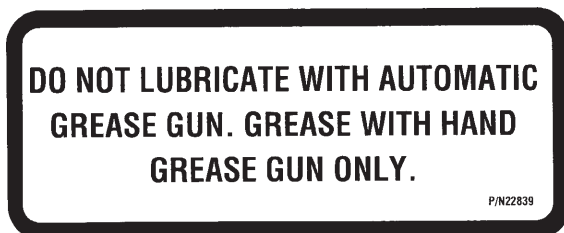

SAFETY



PART NO.
LOCATION

22840
INSIDE OF CAB



24028
MOWER DECK

25387
INSIDE OF CAB



10" x 5.5" 31522
MOWER DECK, MAIN BOOM
18.25" x 10" 31523
HYDRAULIC TANK
13.5" x 7" 31513

SAFETY



PART NO.
LOCATION

27001
INSIDE OF CAB

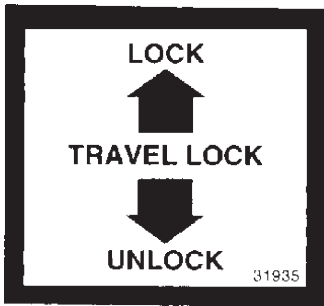

31935
INSIDE OF CAB

DANGER

1. EACH REAR WHEEL MUST HAVE A MINIMUM OF 1500 POUNDS CONTACT WITH THE SURFACE TO PREVENT LATERAL INSTABILITY AND POSSIBLE TIP-OVER WITH BODILY INJURY. WIDEN WHEEL TREAD AND ADD WEIGHTS IF NEEDED. SEE MANUAL OR CALL TIGER CUSTOMER SERVICE FOR COUNTERWEIGHT PROCEDURE.

2. TRANSPORT CAREFULLY! SLOW DOWN EVEN MORE ON SLOPES AND WHEN TURNING; NEVER TURN UP A SLOPE SHARPLY OR AT HIGH SPEED; AND USE EXTRA CARE IN ROUGH OR BUMPY AREAS TO PREVENT OVERTURN AND POSSIBLE CRUSHING INJURY OR DEATH. IF YOUR VIEW TO THE REAR IS BLOCKED, IT IS YOUR RESPONSIBILITY TO INSTALL MIRRORS THAT PROVIDE A REAR VIEW TO PREVENT ACCIDENTS FROM BLIND SPOTS.

3. REAR-MOUNTED BOOM MOWERS MOVE CENTER OF GRAVITY TO THE REAR AND REMOVE WEIGHT FROM FRONT WHEELS. ADD FRONT BALLAST UNTIL AT LEAST 20% OF TRACTOR'S WEIGHT IS ON FRONT WHEELS TO PREVENT REARING UP, LOSS OF STEERING CONTROL, AND POSSIBLE INJURY.

4. NEVER OPERATE UNIT WITHOUT AN OPS (OPERATOR PROTECTIVE STRUCTURE) OR CAB TO PREVENT INJURY FROM OBJECTS THROWN FROM GROUND AND OVERHEAD TRIMMING. STOP CUTTING IF ANYONE IS WITHIN 100 YARDS.

5. KEEP THE BOOM AND CUTTERHEAD AT LEAST 10 FEET FROM ELECTRIC LINES AND PIPE LINES TO PREVENT ACCIDENTAL CONTACT AND POSSIBLE SERIOUS INJURY OR EVEN DEATH.

6. WHEN TRANSPORTING BOOM MOWERS ON A TRUCK OR TRAILER, THE HEIGHT OR WIDTH MAY EXCEED LEGAL LIMITS. CONTACT WITH SIDE OR OVERHEAD STRUCTURES OR POWER LINES CAN CAUSE SERIOUS INJURY OR DEATH. LOWER BOOM TO REDUCE HEIGHT AND/OR REMOVE MOWING HEAD TO REDUCE WIDTH TO THE LEGAL LIMITS, IF NEEDED. 32707

32707
HYDRAULIC TANK



42350
MOWER DECK

SAFETY

ATTENTION

**SERVICE HYDRAULIC SYSTEM
WITH UNIVERSAL TRACTOR
HYDRAULIC OIL.**

32708

PART NO.
LOCATION

32708
HYDRAULIC TANK

CAUTION

For your safety and to guarantee optimum product reliability, always use genuine TIGER replacement parts. The use of inferior "will-fit" parts will void warranty of your TIGER implement and may cause premature or catastrophic failure which can result in serious injury or death. If you have any questions concerning the repair parts you are using, contact TIGER, 3301 N. LOUISE AVE., SIOUX FALLS, SD 57107

32709

32709
INSIDE OF CAB

33224
MOWER DECK

Tiger™

33438
MAIN BOOM

SAFETY

PART NO.
LOCATION

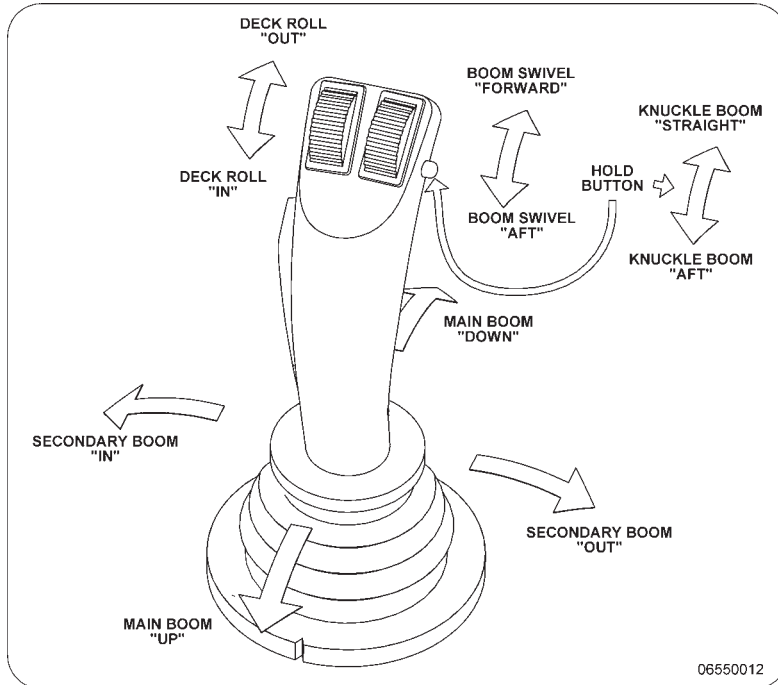

06550012
INSIDE OF CAB

MOWING SAFETY TIPS

- 1 Read & understand the Operators Manual.
- 2 Wear Your Seat Belt.
- 3 Keep all shields and guards in place.
- 4 Make sure equipment is in proper working condition.
- 5 Never attempt to get off or on a moving tractor.
- 6 Never allow riders on tractor or equipment.
- 7 Only start the tractor from the seat with the key.
- 8 Always inspect the area before mowing. Remove all foreign debris.
- 9 Always keep bystanders and coworkers a minimum of 300 feet away.
- 10 Never allow the mower blades to contact solid objects or foreign material.
- 11 Never approach rotating elements.
- 12 Disengage the PTO, place transmission in "Park", set parking brake, shut off engine, and remove key and wait until all rotating motion has stopped before leaving seat.

Tiger

33743

33743
INSIDE OF CAB

SAFETY

PART NO.
LOCATION



RED 42399
REFLECTIVE TAPE
MOWER DECK

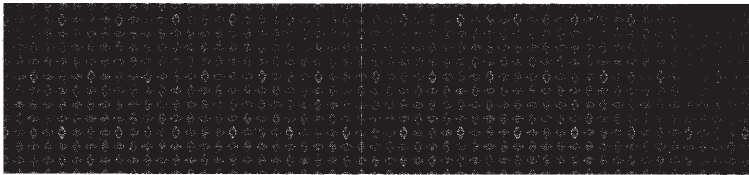

AMBER 4240006
REFLECTIVE TAPE
MOWER DECK



6T3217
MOWER DECK



6T3219
INSIDE OF CAB

6T3220
FRONT PUMP MOUNT

SAFETY



PART NO.
LOCATION

6T3221
INSIDE OF CAB

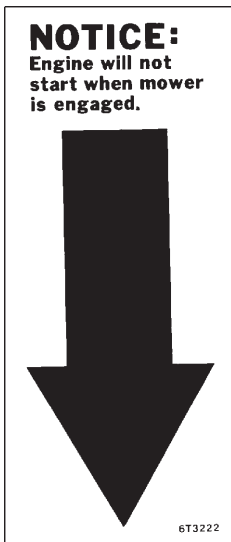

6T3222
INSIDE OF CAB



6T3224
MOWER DECK

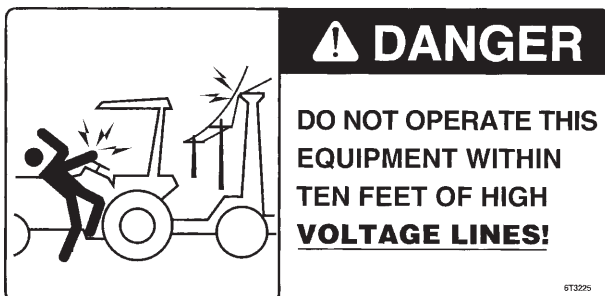

6T3225
INSIDE OF CAB

SAFETY

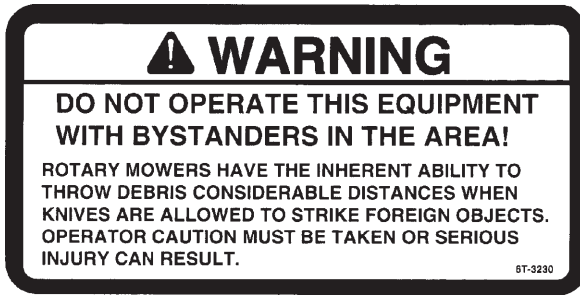

PART NO.
LOCATION

6T3230
INSIDE OF CAB



6T3231
INSIDE OF CAB



6T3233
HYDRAULIC TANK



6T3234
INSIDE OF CAB



6T3236
MOWER DECK

SAFETY

⚠ WARNING

WHEN CUTTING HEAVY BRUSH,
BLADE BOLTS SHOULD BE
INSPECTED HOURLY AND
RETORQUED TO 600 FT. LBS.

6T-3237

6T3237

PART NO.
LOCATION
6T3237
INSIDE OF CAB

<p>DOWN ↑ MAIN BOOM ↓ UP</p> <p><small>06650008</small></p>	<p>OUT ↑ SECONDARY BOOM ↓ IN</p>	<p>OUT ↑ DECK ROLL ↓ IN</p>	<p>CLOSE ↑ SHIELD ↓ OPEN</p>	<p>FORWARD ↑ SWIVEL / SWITCH ↓ AFT</p>	<p>IN ↑ KNUCKLE ↓ OUT</p>
---	--	---	--	--	---

06550008
INSIDE OF CAB

<p>⚠ WARNING</p> <p>IT IS RECOMMENDED THAT THE BOLT AND LOCK NUT BE REPLACED WHENEVER BLADES ARE REPLACED. REPLACE THESE ANY TIME THEY ARE DAMAGED OR WORN AS FAILURE TO DO SO CAN LEAD TO BLADES COMING OFF CAUSING SERIOUS INJURY OR DEATH.</p>	<p>IMPORTANT</p> <ul style="list-style-type: none"> • WHEN REPLACING BLADES, IT IS RECOMMENDED THAT ALL BLADES BE REPLACED FOR PROPER BALANCE TO AVOID EXCESSIVE VIBRATIONS WHICH CAN DAMAGE SPINDLE ASSEMBLY. • SEE YOUR OPERATOR'S MANUAL FOR PROPER INSTALLATION INSTRUCTIONS. <p><small>6T-3243</small></p>
--	--

6T3243
INSIDE OF CAB

GREASING INSTRUCTIONS
CUTTER SHAFT BEARING

GREASE EVERY 8 HRS. OR DAILY

NOTE: If unusual environmental conditions exist-extreme temperatures, moisture, or contaminants-more frequent lubrication is required.

6T3249A

6T3249A
MOWER DECK

GREASING INSTRUCTIONS
GROUND ROLLER BEARING

GREASE EVERY 8 HRS. OR DAILY

NOTE: If unusual environmental conditions exist-extreme temperatures, moisture, or contaminants-more frequent lubrication is required.

6T3261

6T3261
MOWER DECK

SAFETY

⚠ WARNING

**DO NOT OPERATE MOWER
WITH SAFETY SHIELD REMOVED.**

TB1011

TB1011
MOWER DECK



Tiger Corporation

800-843-6849
www.tiger-mowers.com

Description	Application	General Specification	Recommended Lubricant
Tractor Hydraulics	Reservoir	JD-20C	Mobilfluid® 424
Mower Hydraulics Cold Temperatures 0°F Start-up Normal Temperatures 10°F Start-up Normal Temperatures 15°F Start-up High Operating Temperatures Above 90°F Ambient	Reservoir	ISO 46 Anti-Wear/ Low Temp JD-20C ISO 46 Anti-Wear ISO 100 Anti-Wear	Mobil DTE® 15M Mobilfluid® 424 Mobil DTE® 25 Mobil DTE® 18M
Flail Rear Gearbox	Reservoir	PAO Synthetic Extreme Pressure Gear Lube	Mobilube SHC® 75W-90, Mobil 1 Synthetic Gear Lubricant
Cutter Shaft and Ground Roller Shaft (Flail)	Grease Gun	Lithium Complex, NLGI 2 ISO 320	Mobilgrease® CM-S
Drive Shaft Coupler (Rotary and Flail) Drive Shaft Yoke, U - Joint and Stub Shaft	Grease Gun	Lithium Complex, NLGI 2 ISO 320	Mobilgrease® CM-S
Boom Swivel, Boom Cylinder Pivots (Rotary and Flail Boom Type)	Grease Gun	Lithium Complex, NLGI 2 ISO 320	Mobilgrease® CM-S
Deck Boom Pivot & Deck Stop Adjustment (Rotary and Flail)	Grease Gun	Lithium Complex, NLGI 2 ISO 320	Mobilgrease® CM-S
Deck Spindle (Rotary)	Grease Gun	Tiger Spindle Lubricant	Tiger Part #25351

For Mobil product information, availability, or technical information, call 1-800-662-4525.

Tiger PN 34852

34852
HYDRAULIC TANK

SAFETY

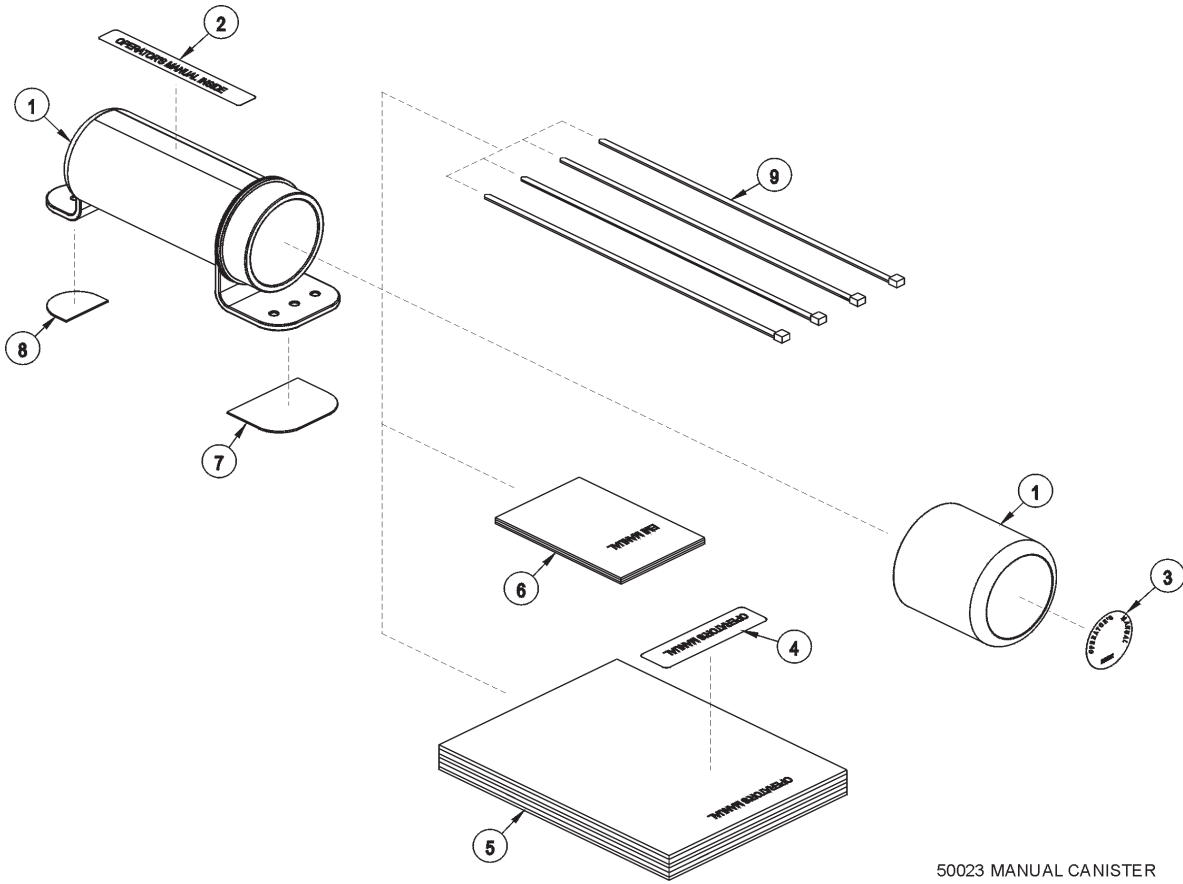

ITEM	PART NO.	QTY.	DESCRIPTION
	50023	AVAIL	MANUAL CANISTER COMPLETE
1	00776031 33997	1 1	ROUND MANUAL CANISTER DECAL, SHEET, MANUAL CANISTER
2		*	DECAL
3		*	DECAL
4		*	DECAL
5	*	AVAIL	SPECIFIC PRODUCT MANUAL
6	33753	1	E M I SAFETY MANUAL
7	34296	1	FRONT ADHESIVE PAD
8	34297	1	REAR ADHESIVE PAD
9	6T1823	4	ZIP TIE 14" LONG

NOTE:

The manual canister can be bolted, zip tied or adhered to a variety of surfaces. Locate a protected area within the view of the operator. Then select an installation method and attach the canister. **CAUTION - AVOID DRILLING HOLES INTO UNKNOWN AREAS**, wires and other parts may be located behind these areas. When adhering the canister to a surface, thoroughly clean that surface before installing the canister.

SAFETY

FEDERAL LAWS AND REGULATIONS

This section is intended to explain in broad terms the concept and effect of federal laws and regulations concerning employer and employee equipment operators. This section is not intended as a legal interpretation of the law and should not be considered as such.

Employer-Employee Operator Regulations

U.S. Public Law 91-596 (The Williams-Steiger Occupational and Health Act of 1970) OSHA

This Act Seeks:

“...to assure so far as possible every working man and woman in the nation safe and healthful working conditions and to preserve our human resources...”

DUTIES

Sec. 5 (a) Each employer-

(1) shall furnish to each of his employees employment and a place of employment which are free from recognized hazards that are causing or are likely to cause death or serious physical harm to his employees;

(2) shall comply with occupational safety and health standards promulgated under this Act.

(b) Each employee shall comply with occupational safety and health standards and all rules, regulations and orders issued pursuant to this Act which are applicable to his own actions and conduct.

OSHA Regulations

OSHA regulations state in part: “At the time of initial assignment and at least annually thereafter, the employer shall instruct every employee in the safe operation and servicing of all equipment with which the employee is, or will be involved.”

Employer Responsibilities:

To ensure employee safety during Tractor and Implement operation, it is the employer’s responsibility to:

1. Train the employee in the proper and safe operation of the Tractor and Implement.
2. Require that the employee read and fully understand the Tractor and Implement Operator’s manual.
3. Permit only qualified and properly trained employees to operate the Tractor and Implement.
4. Maintain the Tractor and Implement in a safe operational condition and maintain all shields and guards on the equipment.
5. Ensure the Tractor is equipped with a functional ROPS and seat belt and require that the employee operator securely fasten the safety belt and operate with the ROPS in the raised position at all times.
6. Forbid the employee operator to carry additional riders on the Tractor or Implement.
7. Provide the required tools to maintain the Tractor and Implement in a good safe working condition and provide the necessary support devices to secure the equipment safely while performing repairs and service.

Child Labor Under 16 Years of Age

Some regulations specify that no one under the age of 16 may operate power machinery. It is your responsibility to know what these regulations are in your own area or situation. (Refer to U.S. Dept. of Labor, Employment Standard Administration, Wage & Home Division, Child Labor Bulletin #102.)

SAFETY

ASSEMBLY SECTION

ASSEMBLY

Before attempting to mount your Tiger mower, it is important to read and understand all of the Safety Messages in the Safety section of this manual.

Check complete shipment list against the packing list to make sure there are no shortages. Make certain the tractor model is the appropriate one for the mower received!



Always use a floor jack, hoist or fork lift to lift and raise heavy parts.

Read and understand the entire assembly section instructions before attempting to mount your Tiger mower. Refer to the parts section of this manual for detailed illustrations to locate all parts. (ASM-C-0001)

TRACTOR PREPARATION

- A. Remove right and left hand steps.
- B. Disconnect battery cables from both batteries.
- C. Remove engine side panels, or raise hood to access front pulley.
- D. Remove plugs from tractor casting where main frame and pump mount will be attached.
- E. Remove any front weights and weight supports.
- F. Raise the tractor onto jack-stands and remove the right and left rear wheels.

(ASM-JD-0001)

CRANKSHAFT ADAPTER

If necessary remove the four capscrews from the crankshaft pulley. Then install the crankshaft adapter and spacer to the pulley with capscrews and lockwashers as shown in the parts section

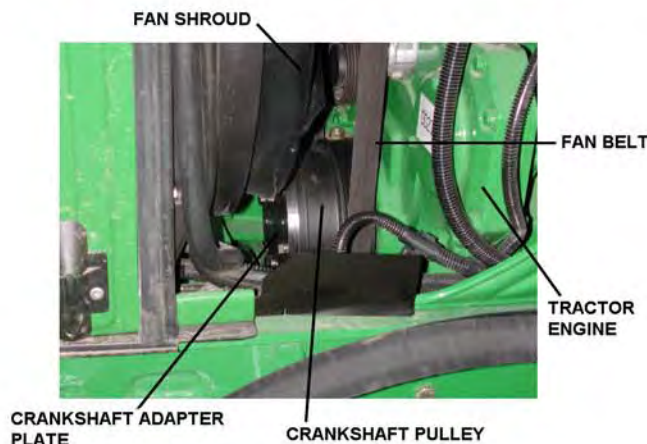

ASSEMBLY

DRIVESHAFT & FRONT PUMP MOUNTING

Install spacer plate on tractor engine using bolts and lockwashers as shown in parts section. Grease sleeve section of the driveshaft and install from the side of the engine compartment. Once you have the sleeve section in place, bolt to spacer plate using bolts and lockwashers as shown in parts section. Install shaft end of driveshaft through opening and into driveshaft sleeve. Shaft and sleeve yokes should be aligned, if shaft does not insert easily in sleeve, turn shaft 180°, and then install. Align the notches on the shaft and yoke tube as shown in picture below. **Shaft end must be installed in correct orientation, failure to do so may result in damage to tractor and/or driveshaft.** After installation of shaft end, install pump mount. Next, install pump. After pump is secured, install driveshaft in to pump shaft. The end of driveshaft should be no more than 1/2" away from contact with pump housing. Tighten crimping bolt on driveshaft. Lube driveshaft & check all hoses, flanges, the pump, pump mount, driveshaft and mounting plate to ensure all fasteners are tightened before operation.

CAUTION: DO NOT START THE TRACTOR UNTIL ALL HOSES ARE ATTACHED, TANK IS FILLED WITH PROPER OIL AND BALL VALVES ARE OPEN! STARTING AT THIS TIME WILL CAUSE SERIOUS DAMAGE TO THE PUMP. (ASM-JD-0002)

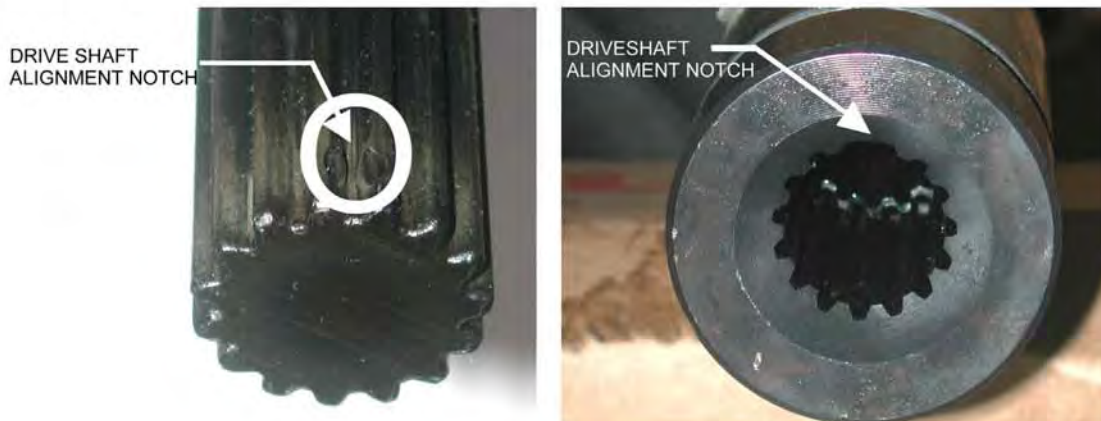

ADJUSTING REAR WHEELS

Raise rear of tractor onto jack-stands. Follow the instructions in the tractor owners manual for adjusting tires and rims. The back wheels MUST be adjusted to the widest setting. NOTE: This may require switching the wheels to opposite sides of tractor. Also take note of any width restrictions when transporting by trailer. (For ease of installation, it is best to leave the rear wheels removed during installation of the mower.) (ASM-B-0001)



ASSEMBLY

POLYCARBONATE SAFETY WINDOW

NOTE: Installing a boom mower requires that all of the right side windows be replaced, or protected with a polycarbonate window. This should be done before mounting the main frame.

- 1 Disconnect gas shock at door. Remove the right side cab door/window glass from tractor cab by removing hinge pins. Also, remove rear right side window.
- 2 Remove the existing hardware and discard factory glass door and window.
- 3 Place small bead of adhesive seal in the bottom of the trim lock bubble bead.
- 4 Install trim lock bubble seal on polycarbonate starting at the center bottom horizontal portion.
- 5 Install existing hardware removed from glass door and window on the polycarbonate.
- 6 Install the polycarbonate assembly in the cab with existing and supplied hardware.
- 7 Place the retaining brackets on the upper front and lower front of the cab door/window with the 8mm capscrews.
- 8 Place the third bracket at the bottom of the door by the fender as shown in the illustration below. Hold the bracket in place and mark the door jam.
- 9 Drill $21/64$ " hole in the door jam for the $5/16$ " capscrew and mount the bracket.
- 10 Install the right rear poly window into place where factory window was removed.

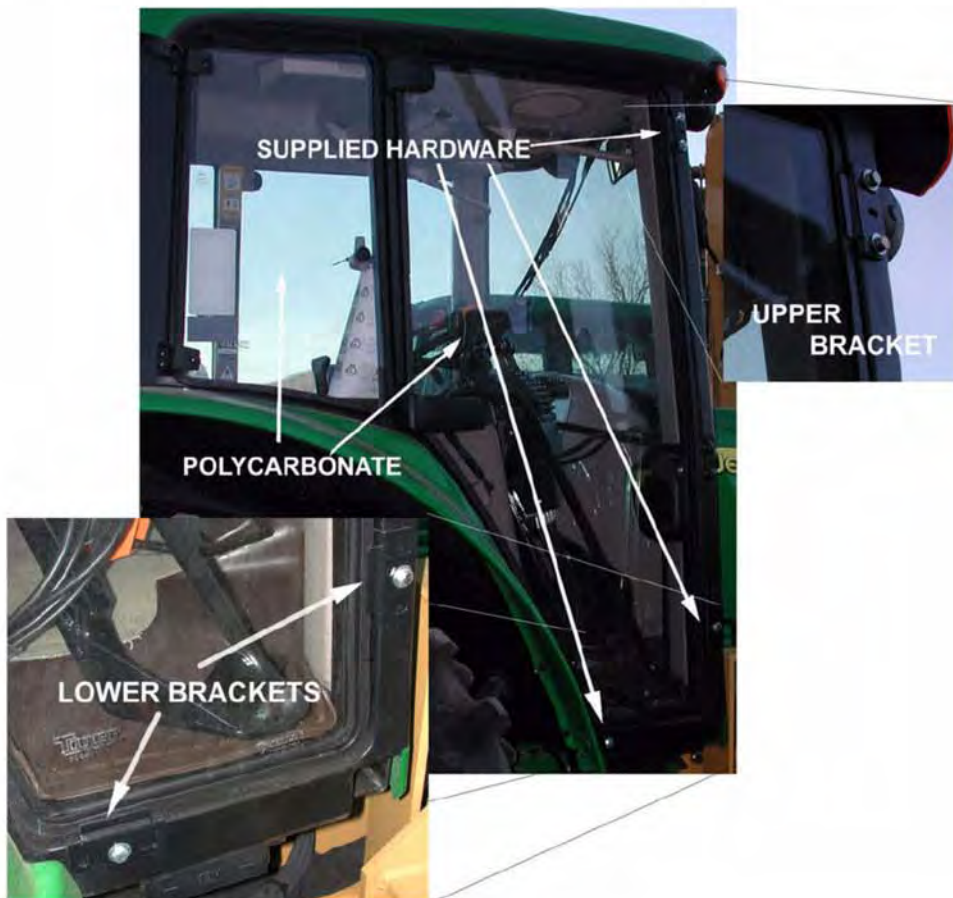

ASSEMBLY

SIDE MIRROR MOUNTING

Disassemble the right side mirror bracket. Cut the square rod and pipe (shown in picture below) 6-1/4". Assemble them together. Mount the right mirror bracket and hardware on upper right corner of tractor cab as shown in picture below. Refer the parts section-safety screen, cab for the hardware details. (ASM-JD7220-0001)

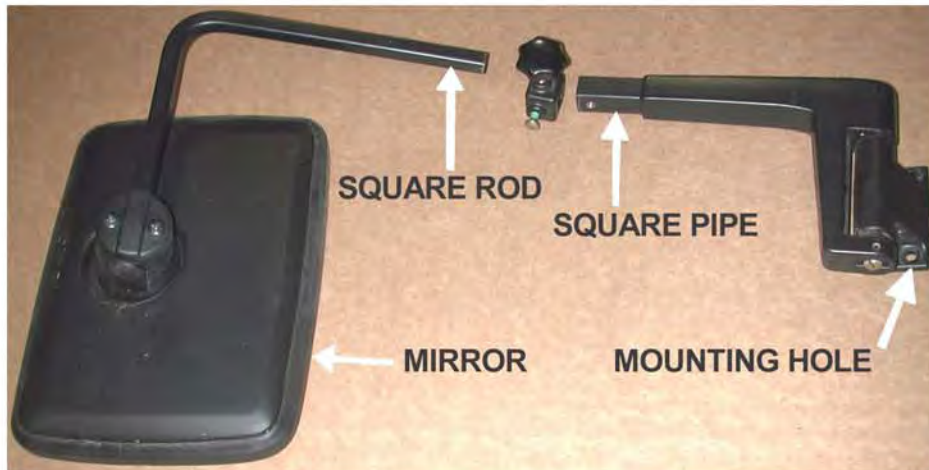

MAIN FRAME INSTALLATION

With an overhead hoist and / or jack-stands, raise one side of the frame up to the correctly matching mounting holes. Install capscrews and all other hardware as shown in main frame parts section to secure the sides of the main frame to the tractor casting, DO NOT tighten at this time. Remove the capscrews one at a time and apply a thread locking agent. Reinsert the capscrews and tighten / torque to values noted in the torque chart located in the maintenance section of this manual. (ASM-C-0003)



ASSEMBLY

CABLE CONTROL LEVER STAND

On the corner cab post, mark a point at 1-3/8" from the windshield and 22 1/2" from the floor; then cut a 3/4" diameter hole through the outer plastic shell. This will expose a threaded steel boss to attach the control box support bracket.

The rear corner of the cable control stand is placed approximately 5 3/4" from the edge of the mat. The front edge of the stand is up against the corner cab post and the door sill lip of the mat. Before you mark or drill any holes, check for support plates or wires under the mat & the cab floor. NOTE: Cutting into plates or wires makes more work for everyone and could be dangerous. When you know where the wires/plates lie, mark one of the mounting holes. Drill a 3/8" hole through the mat and through the floor of the cab. Next, lift the mat up and mark the other two holes on the cab floor. Drill the holes through the floor. Mark the mat and drill the other two 3/8" holes. Use a 1" hole saw and cut a 1" hole through the mat over each 3/8" hole.

Secure the stand to the floor with the spacers, capscrews and nylock nuts provided.



UNDER FLOOR OF CAB

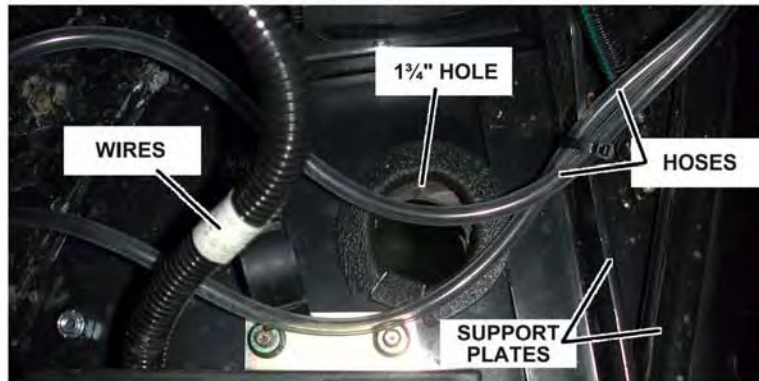

Cut a 1 3/4" hole in the floor to route the cables and wires through. It needs to have a 1/4" clearance for the trim lock. Before you mark or drill any holes, check for support plates or wires under the cab floor.

NOTE: Cutting into plates or wires makes more work for everyone and could be dangerous. Look under the floor for cables and plates that you need to avoid. The hole should be approximately 4 1/2" from the door sill and 4 3/4" from the lip of the mat under the console. Install the trim lock around the metal edges of the hole, then route the control cables and wires through the hole.

Next, wrap the cables with the 6" split hose at the point they pass through the hole, and secure the zip-ties. Apply RTV sealer in and around individual cables and split hose, inside and outside of the cab for a water tight seal. Install upper support bracket from cab post to the control lever stand. (ASM-JD CBL MNT-0002)



ASSEMBLY

SWITCH BOX WIRING

Power for the switch box is accessed through the port located on the lower right rear of the cab. A John Deere plug is used, part number RE67651. DO NOT connect the plug to the cab port until the wiring is completed. The wires in the plug are colored RED, BLACK and ORANGE. The RED wire will always be hot, so it needs to be capped. Attach connector 34538 to end of RED wire and tape wire back on itself. The BLACK and ORANGE wires are hot when tractor key is turned to "on". Connect the BLACK wire of the plug to the BLACK wire from the switch box. Then connect the ORANGE wire of the plug to the RED wire from the switch box.

The two GREEN wires must be connected to the neutral safety wire by cutting the neutral safety wire and connect one GREEN wire to one end and the other GREEN wire to the other. Refer to the switch box schematic and wiring diagram for additional information.

STANDARD MODELS: Neutral Safety wire is a brown wire located under steering column. Cut a slot in the right side of column to access, WATCH OUT for existing wires.

PREMIUM MODELS: Neutral Safety wire is the blue #6076AA wire located under right hand console. Route wires under the console.

After connecting the power to the switch box, route the cables along the floor to the lower right corner of the rear cab window. Space out evenly, the 3 WHITE PUSH MOUNTS (06537011). Drill three 1/4" holes in the console 1"-2" off the floor. You may wish to remove the console to make sure you don't cut into any wires. Thread zip ties through the push mounts and wrap them around the cables from the switch box to the window, MAKE SURE the cables are adjustable. DO NOT TIGHTEN. Cut a small hole in the boot of the window, ONLY large enough to allow the cables through. Pull the cables through the hole until there is a good amount of slack left in the cab. Wrap the cables with Split Hose and route through the hole. Make sure the cable is slightly loose from the switch box to the first zip tie. Tighten the zip tie and remove the excess tie. Continue with the other two, removing slack from the cable as you move toward the back of the cab. Pull any extra cable through the hole, leaving some slack and secure split hose with zip ties.

Route the Danfoss connectors to the plugs on the valve. Route the (1 orange/ 2 black/ 1 white) wires to the front of the tractor along with the hoses. Connect with zip ties. The orange wire and one of the black wires goes back to the travel lock on the Danfoss valve. The white and black wire goes to the brake valve on the main frame. Check with the switch box schematic for additional information. (ASM-JD-0008)



JOHN DEERE
PLUG



DANFOSS CABLE
ROUTING



ASSEMBLY

JOYSTICK SWITCH BOX MOUNTING

Locate the 2 holes in the right front corner of the cab frame. These will be the mounting holes for the 2 mounting bolts of the switch box bracket. See picture below. Mount the bracket using the hardware supplied, as noted in the parts section. (ASM-JD7000-0001)

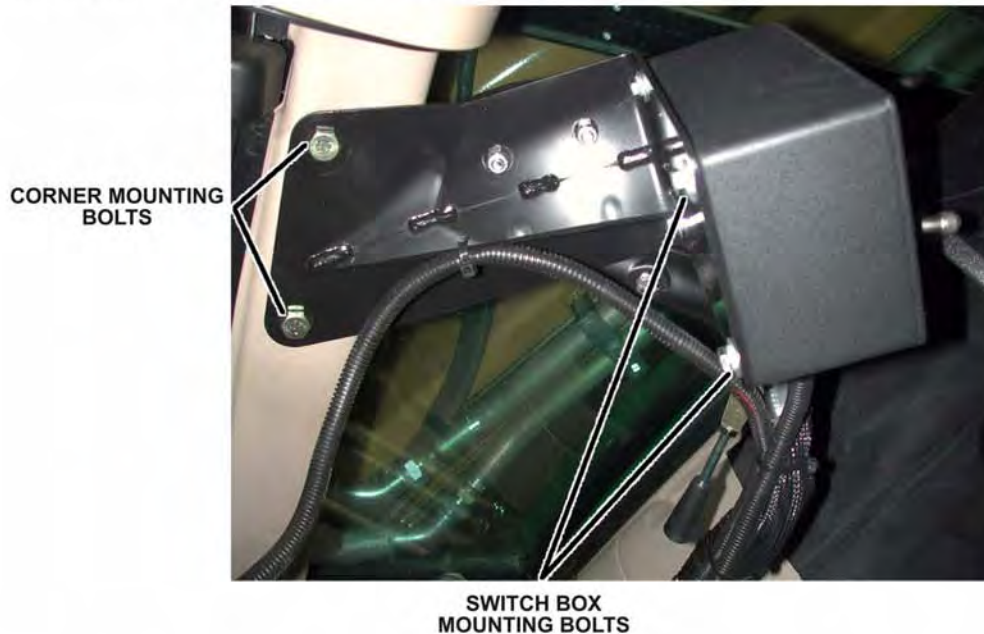

IVT JOYSTICK MOUNTING (SWITCH BOX)

Install the joystick mounting bracket to the side of the switch box bracket. Use the materials in the parts section and the pictures below to assemble the joystick assembly for the IVT.

After the joystick has been mounted final adjustment can be obtained by use of the knob on the mounting bracket. **Note the mounting components must be located so not to interfere with other controls.** Route the joystick cable from the control box to the joystick. Be sure to leave enough slack in the cable to allow for movement of the joystick. Secure the cable to the mounting bracket with cable ties.

(ASM-JD PRM JYSTK ARMST-0001)

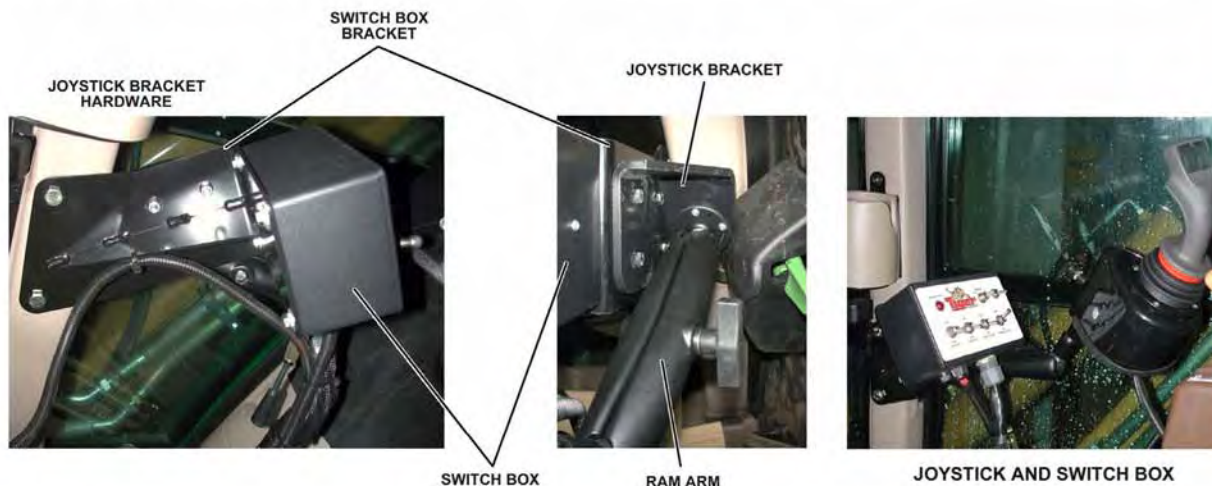

ASSEMBLY

IVT JOYSTICK MOUNTING (SEAT MOUNT)

Parallel the edge of the IVT joystick mount to the edge of the seat frame and mark the holes for drilling. Drill and ream two 3/8" holes through the seat plate with a 90° drill attachment. Drill only through the seat plate not through anything else.

Attach the IVT joystick mount to the seat plate with 3/8" capscrews(heads up.) Secure the mount with the lockwashers and hex nuts provided.

Wedge the jamb nut and knob onto the setscrew and thread it into the side of the joystick mount. Insert the nylon bushings and the formed rod into the tube of the joystick mount and tighten the knob, securing the formed rod.

Insert the nylon bushings for the joystick can into the tube. Wedge the jamb nut and knob onto the setscrew and thread it into the side of the can. Place the can on the formed rod and tighten the setscrew and knob. Attach the joystick to the can with the setscrews provided.

NOTE: Adjust the joystick so the components do not interfere with the other controls.

Route the joystick cable to the floor of the cab by the right console. Then from the console to the switch box. Be sure to leave enough slack in the cable to allow for movement of the joystick. See Switch Box Wiring for information on securing cables to the console.

(ASM-JD IVT JYSTK SEAT MNT-0001)

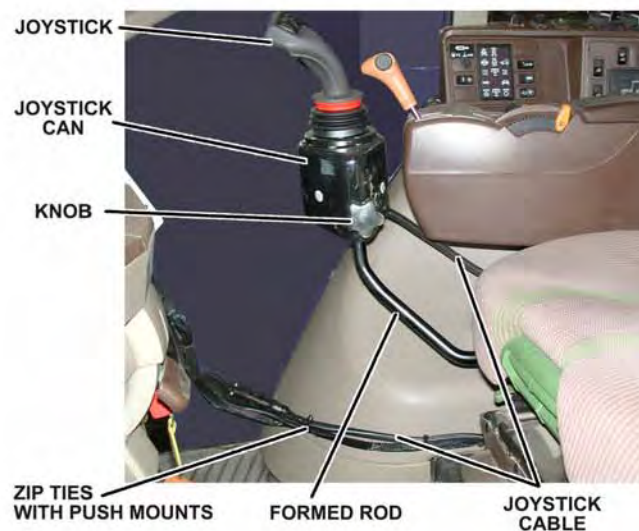
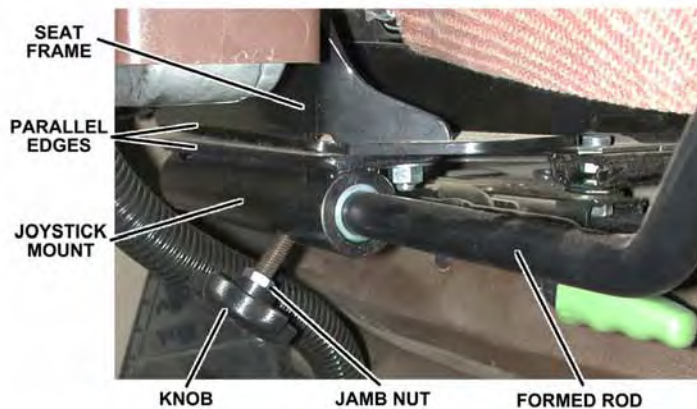

ASSEMBLY

STANDARD ARMREST JOYSTICK MOUNTING

To mount the joystick you will need to remove the right armrest of the seat. First, pop off the plastic cover where the armrest pivots. The nut will have to be removed (where there is an adjustment knob, the knob must be loosened and the cap on the end of the knob must be removed to take the nut off.)



Next, locate the rivet above the remaining bolt. Drill out the rivet with a 3/16" bit, without reaming the washer supporting the rivet. Save the washer for later use.

Use the joystick mounting bracket to mark where you need to drill into the armrest. Drill a 1/4" hole through the armrest and progress to a 1/2" hole for the capscrew.



Then on the drivers side of the armrest, die grind a 3/4" hole through the first metal plate to allow for the Tiger spacer.

Place the mounting bracket on the armrest over the hole. Insert the spacer into the 3/4" hole. Thread the capscrew into the bracket and through the armrest and the spacer. Secure the bracket to the armrest with the nylock nut provided.

Once the holder is installed on the armrest, replace the armrest on the bolt. Replace the washer over the hole where you removed the rivet. Reattach using a new 3/16" rivet. Finally, secure with the existing nut and replace all covers. Then install the joystick in the holder with the machine screws as shown in the parts section. (ASM-JD STD JYSTK ARMST-0001)



ASSEMBLY

PREMIUM ARMREST JOYSTICK MOUNTING

Remove the Armrest.

Place the joystick mounting bracket on the armrest. Use the bracket holes to mark the three holes to drill through the armrest. Remove the armrest and drill three $\frac{1}{4}$ " holes through the inside of the armrest. Die grind a $\frac{1}{2}$ " hole through the first layer of plastic for the Machine screws to go through.

Place the joystick mount on the armrest so the center knob fits into the hole and the holes line up between the mount and the armrest. Use the three machine screws to secure the joystick mount to the armrest.

Once the holder is installed on the armrest, replace the armrest. (ASM-JD PRM JYSTK ARMREST-0001)



ASSEMBLY

HYDRAULIC PORTS (PREMIUM)

These ports are located under the tractor rear remotes and are located as shown in the image below. Refer to the PARTS section for additional information.

(ASM-JD60-7030-0002)

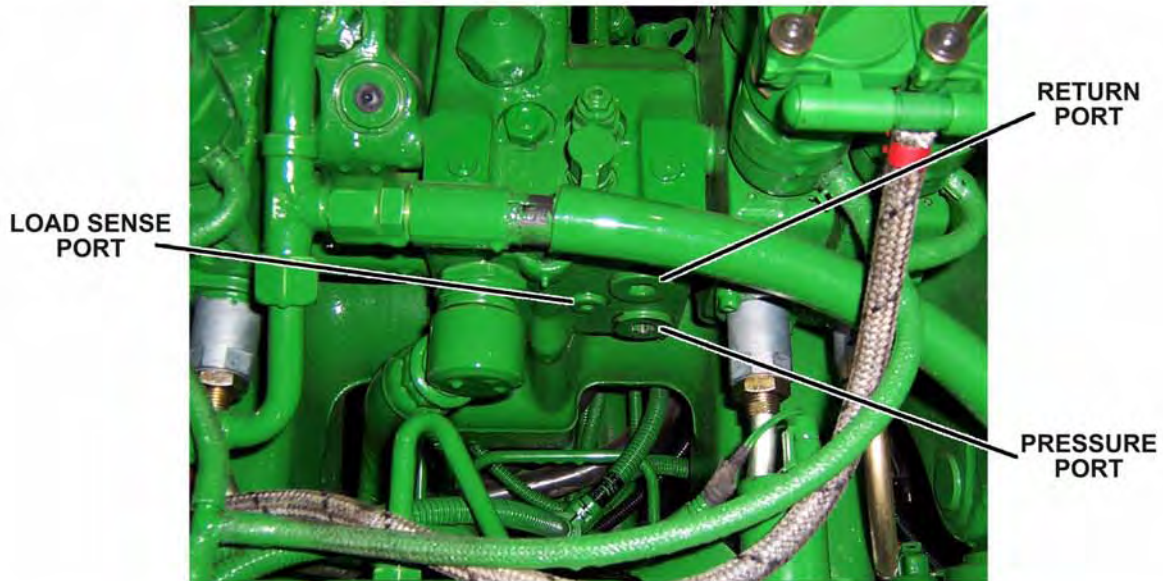

HYDRAULIC PORTS (STANDARD)

These ports are located at the rear of the tractor, under the lift valve, where the valve mounting bracket attaches to the tractor. The load sense port is on top, then the pressure and finally the return port, as shown in the image below. Refer to the PARTS section for additional information.

(ASM-JD60-7030-0004)

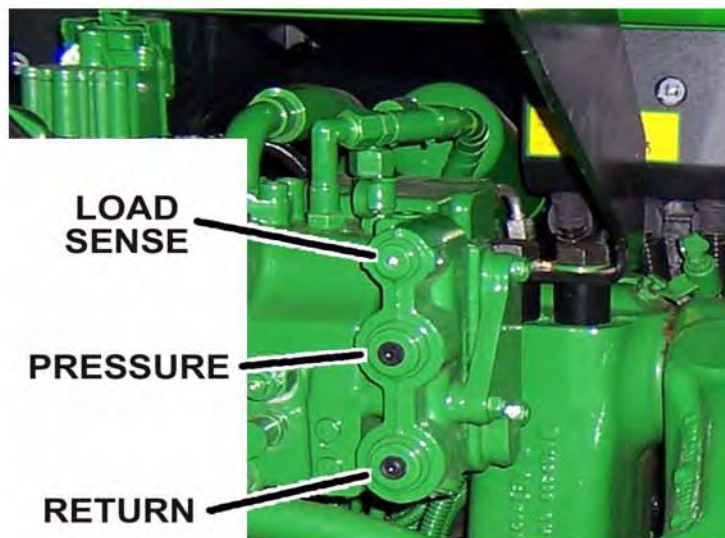

ASSEMBLY

HYDRAULIC LINE PLUMBING:

PRESSURE LINE INSTALLATION

The hydraulic pressure line will be plumbed into the rear of the tractor remote valve. Locate the pressure port on the rear remotes and remove the plug (refer to the Hydraulic Ports illustration and the Parts Section pages for position of the pressure port). After the plug is removed then install 27mm adapter. Next connect a 1/2" hose from the tractor remote valve to the Tiger valve. (ASM-27mmPRESSURE-0001)

RETURN LINE INSTALLATION

The return line will be plumbed next to the pressure line on the tractor remote valve. Locate the return port and remove the plug (refer to the Hydraulic Ports illustration and the Parts Section for the position of the return port). After the plug is removed then install 27mm adapter or elbow. Next connect a 1/2" hose from the tractor remote valve to the Tiger valve. (ASM-27mmRETURN-0001)

LOAD SENSE LINE INSTALLATION

The load sense line will be plumbed into the bottom of the tractor remote valve (refer to the Hydraulic Ports illustration and the Parts Section pages for the position of the load sense port). Locate the plug on the tractor rear remotes for the load sense, and remove the plug. Install a 14mm adapter or elbow and run a 1/4" hose from the remotes to the Tiger valve. Refer to the Parts Section pages for an exploded diagram of the tractor remote valve hookup. (ASM-14mmLODE SENSE-0001)

DANFOSS VALVE

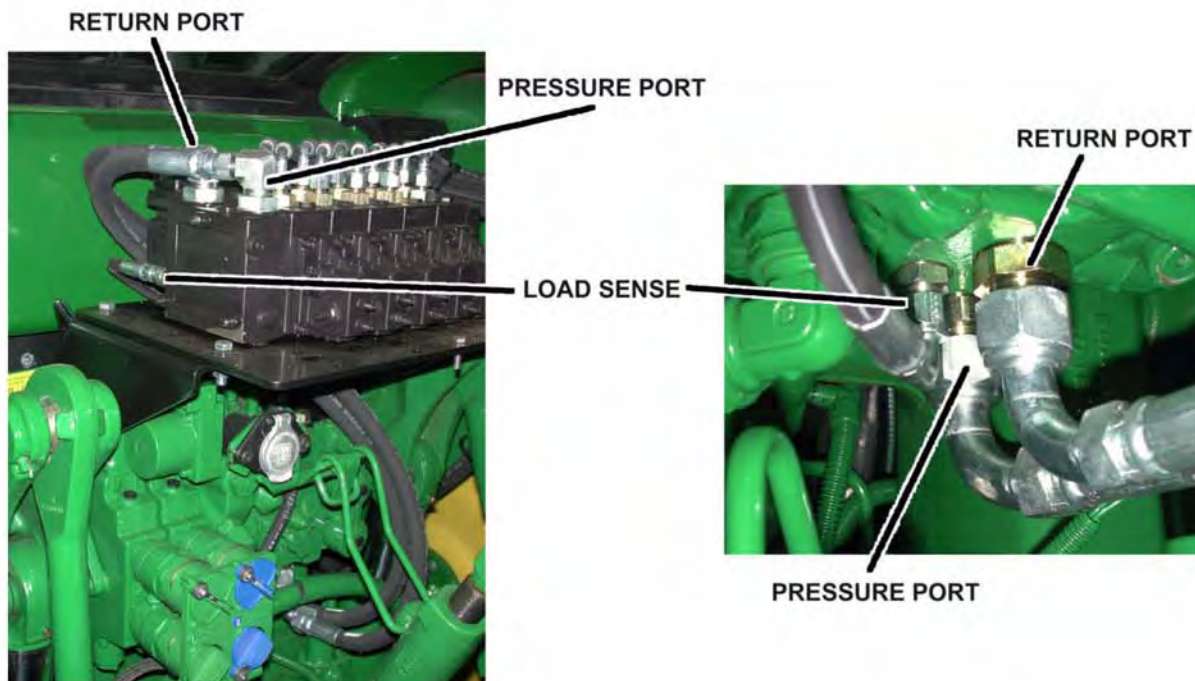

ASSEMBLY

HUSCO VALVE

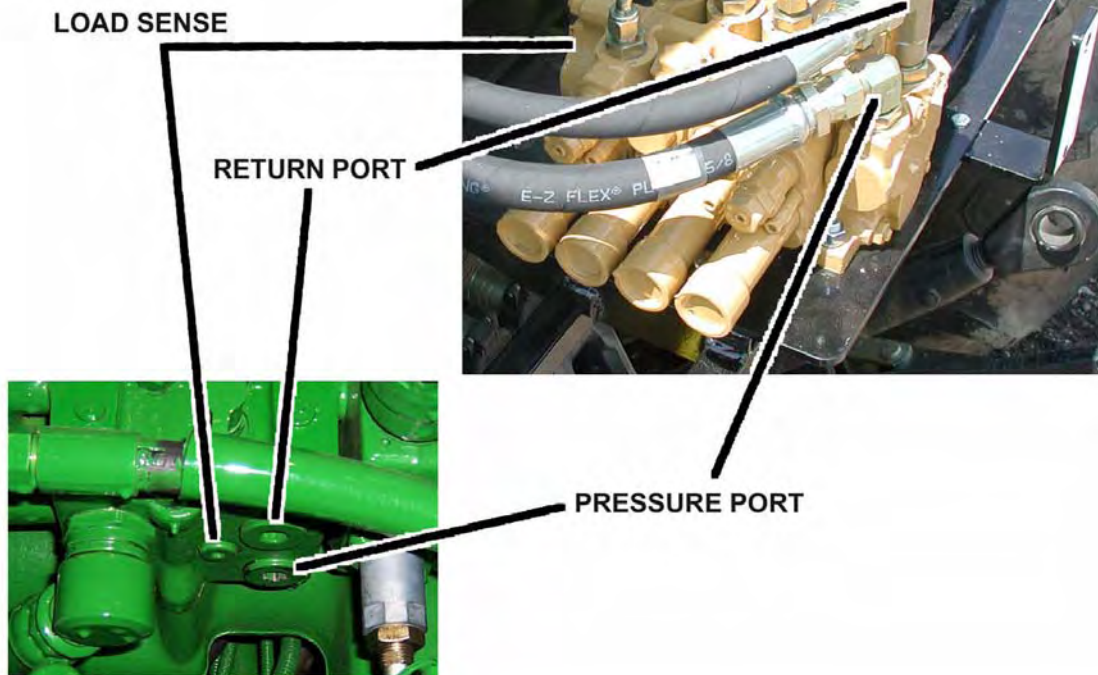

VALVE MOUNTING

Locate the existing holes on top of the tractor remote valve at the rear of the tractor. Spacers are needed under the valve mounting bracket to raise the valve mounting system to the required height. Secure the bracket to the tractor with hardware shown in the parts section of the manual. Attach the valve mounting plate to the valve mounting bracket on the rear of the tractor as shown below. Align the holes for the cables on the Husco control valves and center the Danfoss valve on the valve plate. Then align the holes on the valve with the plate holes and secure the lift valve on top of the mounting plate. Route the hydraulic lines from the lift valve to the hydraulic cylinders as noted on the lift valve page of the parts section. Install the control cables to the valve and the mounting plate on the Husco valves. On the Danfoss valves, attach the electrical control cables. (ASM-JD7X30-0001)

GENERAL HOSE INSTALLATION

Refer to the parts section for detailed information about hoses and fittings for this application. (ASM-C-0011)

ASSEMBLY

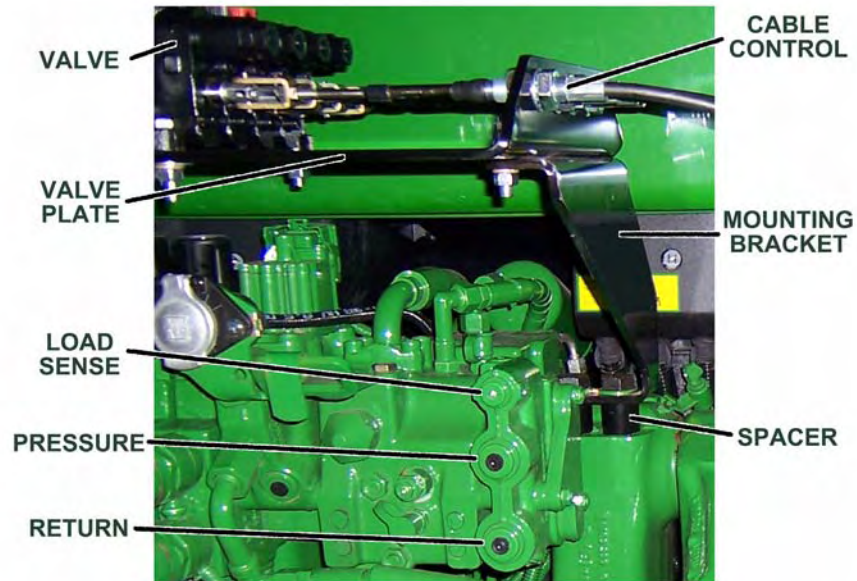

FILLING HYDRAULIC RESERVOIR

Refer to the maintenance section for filling specifications and hydraulic oil requirements.

NOTE: Starting or running your Tiger mower before filling reservoir will cause serious damage to hydraulic pump.

(ASM-C-0004hydro resrv)

PLUMBING DECK ROTATION ON TRACTOR REMOTES

Hose 34358 to main boom shall be connected to quick disconnects and connected to ports A and B of tractor remote valve #1. This should provide Deck Rotation function such that moving remote valve lever "forward" will cause deck to rotate "counter-clockwise" and moving lever "aft" will cause deck to rotate "clockwise". Note that the flow control for this tractor remote valve should be adjusted to rotate deck from the full "clockwise" position to the full "counter-clockwise" position in 15-20 seconds.



ASSEMBLY

REAR STOW BENGAL HOSE ROUTING

WARNING NOTE: The sudden release of hydraulic pressure could cause the sudden movement of very heavy parts. Anyone in the way of these parts could be severely hurt or killed. DO NOT ALLOW these hydraulic hoses to BREAK or BURST in order to prevent hydraulic failure. Make sure the hoses do not pinch or stretch as boom moves. Measure TWICE, check TWICE then proceed with caution.

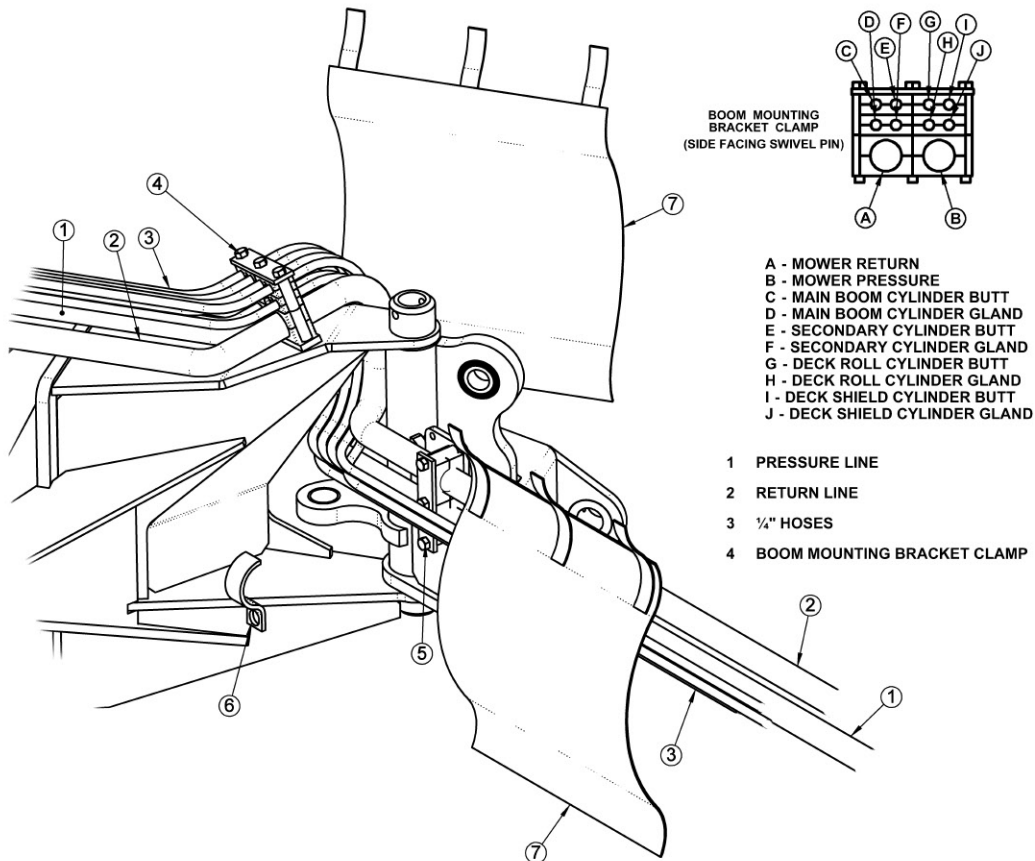

Route the hoses through the space between the swivel and the boom mounting bracket. Connect the hoses to the preformed tubes and move the boom arm to a few feet from full forward. Assemble the swivel clamp and place the return hose for the motor on top and the pressure line on the bottom. Place the 1/4" hoses in the "C" clamp and add it to the bottom screw of the swivel clamp. Next, make sure there is enough slack for all hoses to pivot at the joint where the main boom arm bends in the swivel, as shown in the next image, and tighten the hoses in the clamp.



ASSEMBLY

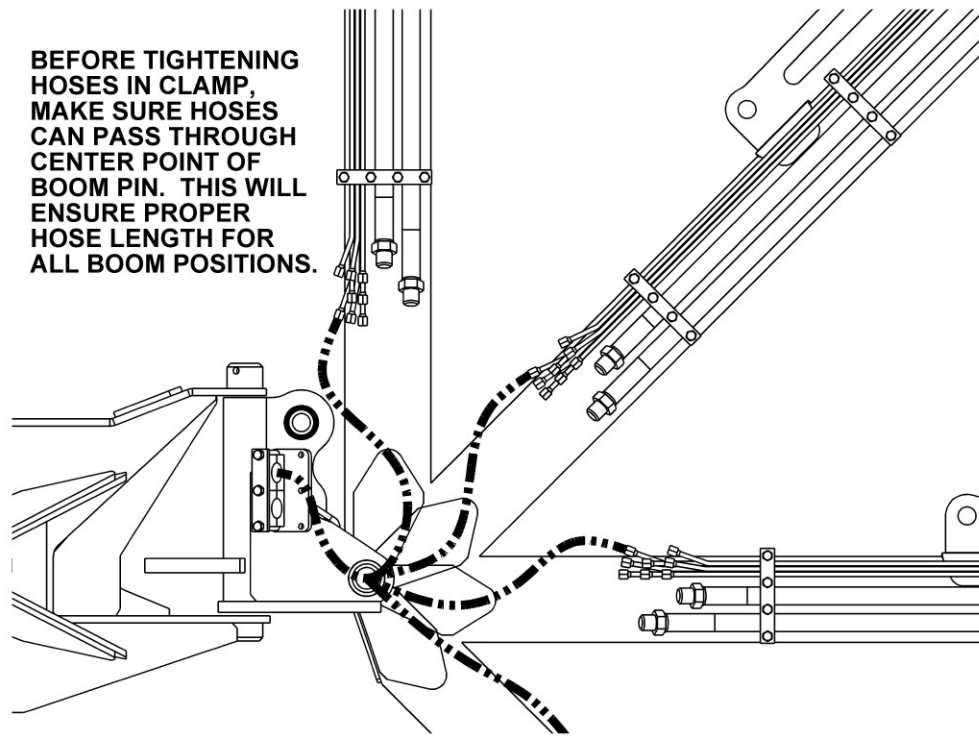

Arrange the hoses in the clamp that attaches to the boom mounting bracket as shown above, with the 1" motor hoses closest to the bracket and the return hose closest to the boom arm. Pull the hoses snug from the swivel to the mounting bracket clamps, when main boom is still forward, and tighten the hoses in the clamp.

Make sure the 1" motor hoses do not kink as the boom arm is moved into the stowing position. If this happens the motor hoses will have to be shortened, because there is too much hose between clamps. (ASM-30S, 3PS HOSE ROUTING-0001)



ASSEMBLY

BOOM HYDRAULIC DIAGRAM

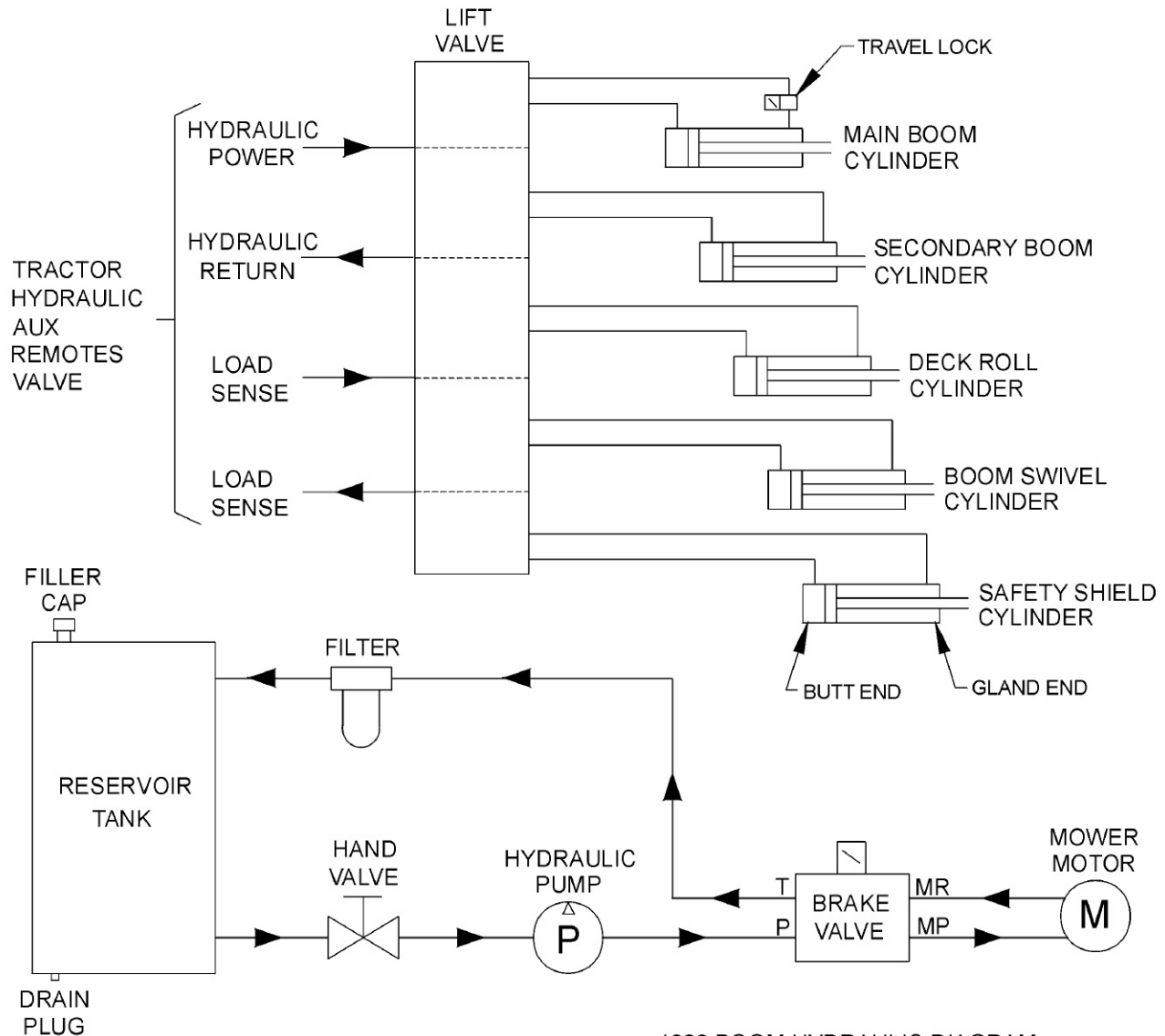

1320 BOOM HYDRAULIC DIAGRAM

HYDRAULIC TANK INSTALLATION

Install all fittings and tubes into tank and tank filter as shown in the parts section illustration. Insert tank sight glass into front side of tank.

Place the tank in the mounting bracket on the main frame as shown in the parts section. Secure the tank with the tank channel mount by placing the channel mount on top of the tank and the washers over the holes. Thread the tie bolts through the washers and holes to the threaded holes on the main frame. Tighten the tank channel mount by using the hex heads on the end of the tie bolts.

Install the filter gauge into the filter housing so that it points to the rear of the tractor and is clearly visible to the operator. The tank breather cap is ready for use as the tank is filled. Some of the for-metioned items may be already installed. (ASM-MOTOR HYDRO-0001)



ASSEMBLY

NOTE ON HUSCO CONTROL VALVES

Manual, cable controlled (Husco control valve) boom mowers require check valves with integral restricting orifice (#06502036) installed in the control valve work ports that are connected to the gland ends of the main and secondary boom cylinders. This check valve allows oil to free flow into the gland end of the main and secondary boom cylinders, but restricts flow out of the cylinder, thereby providing proper boom control. This check valve, #06502036 (Vendor #1968R-.063) is similar in appearance to hose adapter #33271 and Adapter #34396, with .06 orifice. These components can be identified as follows, and are to be installed per parts section for the lift valve. (ASM-HUSCO-0001)

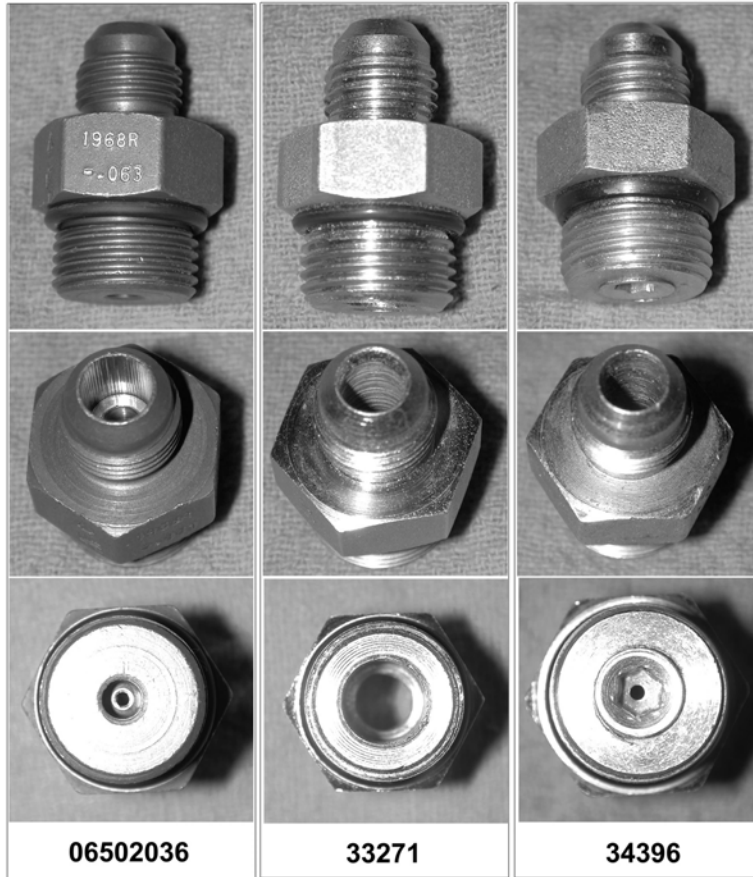

ACCUMULATOR INSTALLATION

Install the accumulator bracket on tab with holes provided on the right main frame with the capscrews and lockwashers shown. Install the accumulator in the bracket and secure with the hardware shown. Install fittings and hoses to the cylinder and control valve as shown in the parts section. **Use teflon tape on all pipe fittings (except O-rings).** (ASM-C-0012)



ASSEMBLY

AXLE BRACE MOUNTING

The axle braces are to be mounted under the rear axle of the tractor. The other end of the axle brace mounts on the outside of the lower rear corners of the main frame. After attaching the boom rest, it should fit tightly and level under the tractor. Attach the right axle brace to the main frame with hardware shown in the parts section and tighten. Attach the axle braces to the rear axle using the mounting hardware shown in the parts section, but DO NOT tighten.

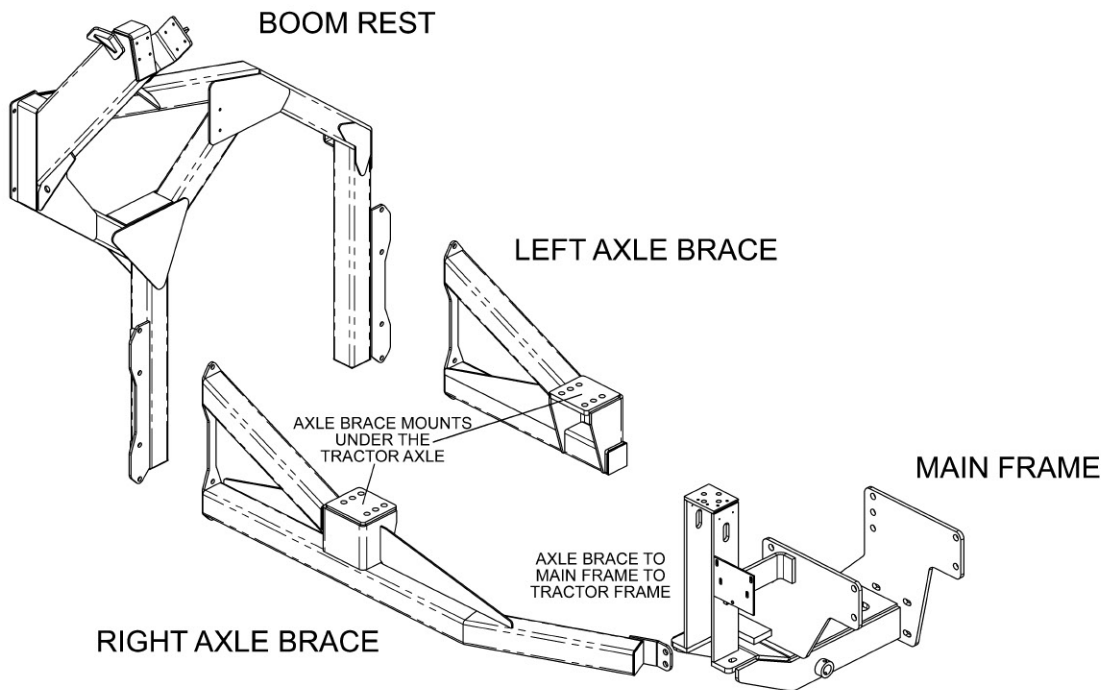

BOOM REST MOUNTING

Carefully raise the boom rest and align the holes with those of the axle brace. Now install all attaching hardware as shown in the parts section loosely, to allow for the alignment with the left and right axle brace. Tighten / torque all hardware on the brace and the boom rest. If mounting the 60" rotary head, attach the additional stop to the lower resting position as shown in the parts section. Finally, add the rest strips to the boom rest as shown in the parts section. (ASM-JDBOOM-0001)



ASSEMBLY

MAIN BOOM INSTALLATION

Install the boom swivel into the main frame as shown in the parts section using a hoist. Line up holes in swivel and main frame for large swivel pin and insert pin. Secure with hardware as shown.

Attach the inner end of the main boom to the swivel bracket with the cylinder anchors positioned upward, and at a right angle to the tractor. Secure it with the horizontal hinge pin. Secure the hinge pin in the boss with capscrews, etc. (see parts section).

Attach the butt end of the main boom cylinder to the swivel bracket anchor with the special "bracket head" cylinder pin and roll pin shown in parts section.

Install the travel lock on the rod end of the main boom cylinder. This should be facing the butt end of the cylinder after installation.

Install the fittings and hoses to the main boom cylinder per parts section.

GREASE HINGE PIN ZERKS ON BOOM AFTER ASSEMBLY, ONCE UNDER LOAD WITH BOOM ELEVATED AND AGAIN AT REST WITH BOOM SUPPORTED (ASM-C-0013)

WHEEL WEIGHT MOUNTING

For all mowers using a boom mower, a wheel weight will be required for the left side wheel. It will be necessary to mount the 1300 pound wheel weight in the wheel using the long capscrews, lockwashers, flatwashers, and hex nuts per diagram in the parts section.

Installation is most easily done with a small fork lift, inserting a fork in the center slot of the wheel weight. The head of the capscrews is to be toward the OUTSIDE of the weight, with flatwashers on both inside and outside of the assembly.

The left rear tire must also be filled with a mixture of water and calcium chloride at about five pound per gallon. Tire air pressure should be maintained at approximately 22 P.S.I. (ASM-C-0013)



ASSEMBLY

WEATHER-PACK/METRI-PACK ASSEMBLY

These instructions apply to both Weather-Pack and Metri-pack connectors.

NOTE: Use the specific tool for the type of connector you are assembling.

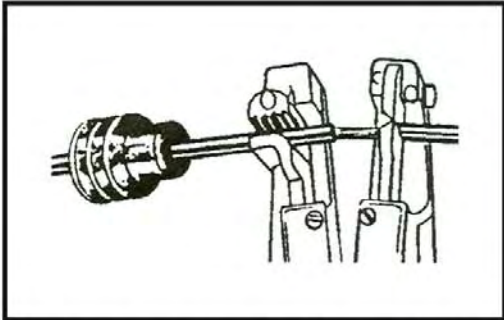

1. Apply seal to cable, before stripping insulation.



2. Align seal with cable insulation.

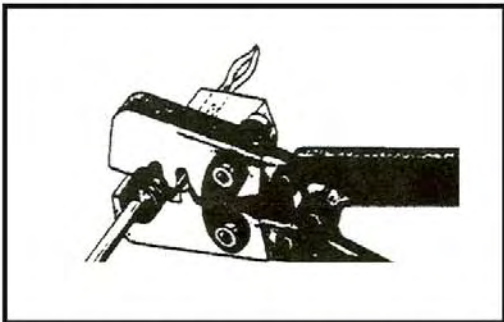

3. Put terminal in crimping tool, then position wire and seal in place.

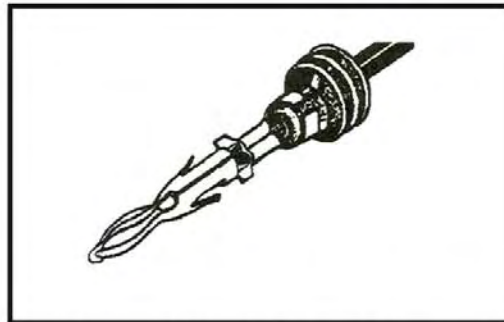

4. Crimp and visually inspect for a good crimp before installing in connector body.

(ASM-C-0009)



ASSEMBLY

BOOM JOYSTICK CONTROL CALIBRATION (FOR SIDE STOW) SUB-D

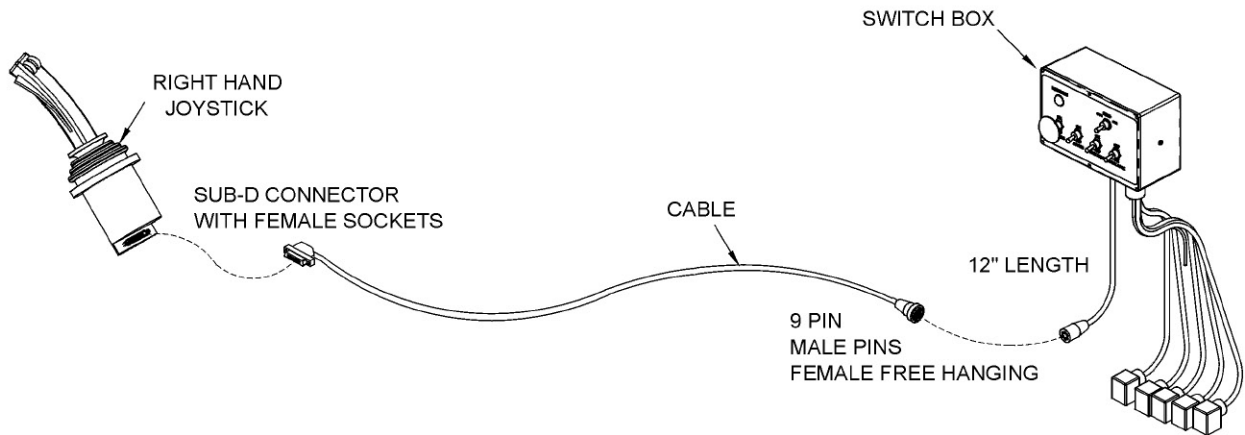

This Danfoss PVG32 control valve is now equipped with higher-resolution actuators on Main Boom, Secondary Boom, Deck Roll, and Swivel functions. These actuators have “active fault monitoring”. The Deck Shield section does not have “active fault monitoring”. The joystick is unchanged and provides a ratio-metric voltage signal. The neutral signal voltage is half or 50% of tractor supply voltage. A 25% signal voltage will shift the valve spool to full “A-Port”, and 75% signal voltage will shift the spool to full “B-Port” in the Main, Secondary, and Swivel valve sections. On the Deck Roll function a 34% signal voltage will shift the valve spool to full “A-Port” and a 68% signal voltage will shift the spool to full “B-port”. If an actuator with active fault monitoring receives a signal from the joystick that is less than 15% or greater than 85% of supply voltage the actuator will “fault out” and shut down. Also if there is an internal failure in the actuator or if the spool position is greater than that specified by the signal voltage from the joystick, the actuator will “fault out” and shut down. An “active fault” condition causes the actuator to drive the spool to neutral, shut down, and activate a “red” LED on the top of the actuator. The active fault can be canceled by simply cycling the Master Switch “OFF” and then “ON”, which resets the fault monitoring, and causes the LED on top of the actuator be “green” again.



The joystick control is equipped with signal adaption potentiometers.

These provide the capability to individually adjust the oil flow to each boom function. It is important that the boom functions do not travel too fast. Excessive boom speed can reduce the stability of the unit and decrease operator control.

Note: Use a Phillips screw driver and be sure to adjust the screws carefully! DO NOT turn the potentiometers beyond their stopping point, potentiometers are very delicate! Turning the “A” or “B” port potentiometers clockwise increases the oil flow to increase the boom function speed, and turning them counterclockwise decreases the oil flow to decrease the boom function speed. See the graphic on the next few pages for help in adjusting.



ASSEMBLY

Run tractor at normal operating RPM to adjust the settings as follows.

Set the dead band compensation potentiometer first.

Set the dead band compensation potentiometer at 50%, or halfway between full clockwise and full counter-clockwise.

Setting Signal Adaptation Potentiometers:

Disconnect the Deutsch connectors from the actuators of the valve. Use a Volt/Ohm meter to measure signal voltage and adjust the signal adaptation potentiometers as needed. Pin #4 is tractor supply voltage. Pin #1 is signal voltage from the joystick, and pin #3 is ground. First measure supply voltage between pins 4 and 3. Then measure signal voltage between pins 1 and 3 while indexing the joystick function fully in both the "A" and "B" port direction. Divide the signal voltage by the supply voltage to get signal voltage as a % of supply voltage. This percentage should not be less than 25% or greater than 75% for the Main Boom, Secondary Boom, or Swivel function. This percentage should not be less than 30% or greater than 62% for the Deck Roll function. Note these initial settings for the Deck Roll function should prevent the spool from shifting into float. *After making this first adjustment to deck roll if the spool still goes into float, adjust the "B" port screw additionally counterclockwise.*

Reconnect Deutsch connectors on control cables to actuators on Danfoss valve. Run tractor until hydraulic system is at operating temperature. Now refine the adjustments of the signal adaptation potentiometers for both "A" and "B" ports for all proportional functions to achieve the following function times. Note: turning potentiometer clockwise increases the flow or the function speed, and turning them counter-clockwise decreases the flow or the function speed. Note, if during this procedure the trim potentiometer is set to full "counterclockwise" but the function is still too fast, use the mechanical stops at the manual actuator end of the valve section to further limit flow. Turn limit screw in or clockwise to limit flow. The upper limit screw limits flow to "B-port", and the lower limit screw limits flow to "A-port". However DO NOT adjust the limit screw on "B-port" of deck roll function. Limiting "B-port" will prevent "float" function.



ASSEMBLY

MAIN BOOM: "A" Port, Boom UP: 7-9 Seconds

(Note: Extend secondary boom completely; roll deck to be level with ground, and lower main boom until deck is on ground. Now index main boom "up" function and determine the time required for main boom to rise completely.)

"B" Port, Boom Down: 6-8 Seconds

(Note: Extend secondary boom completely, roll deck to be level with ground, and raise the main boom to "full up". Then index the main boom "down" function to determine the amount of time required for the deck to contact the ground. CAUTION: Stop the boom just as the deck contacts the ground.)

SECONDARY

BOOM: "A" Port, Boom Out: 8-10 Seconds

(Position main boom full up, roll deck out until deck cylinder is fully retracted, and bring secondary boom in completely. Then index the secondary boom "out" function and determine the time required for boom to extend out completely.)

"B" Port, Boom In: 8-10 Seconds

(Position the main boom full up, roll deck out until deck cylinder is fully retracted, and extend secondary boom completely. Then index the secondary boom "in" function and determine the time required for boom to come in.)

DECK ROLL: "A" Port, Deck Out: 7-9 Seconds

(Raise main boom to vertical, extend secondary boom out slightly so that deck can be articulated without contacting the main boom, and roll deck in until deck cylinder is completely extended. Then index the deck roll "out" function and determine the time required for the deck to roll out.)

"B" Port, Deck In: Target 7-9 Seconds (but DO NOT use Limit Screw)

(Raise main boom to vertical, extend secondary boom out slightly so that deck can be articulated without contacting the main boom, and roll deck out until deck cylinder is completely retracted. Then index the deck roll "in" function and determine the time required for the deck to roll in.)

BOOM

SWIVEL: "A" Port, Boom Aft: 6-8 Seconds

(Extend booms completely; rotate head to be level with ground, lower main boom until deck is just above ground, and swivel boom full forward. Then index the boom swivel "aft" function and determine the time required for the boom to swivel full aft.)

"B" Port, Boom Forward: 6-8 Seconds

(Extend booms completely, rotate head to be level with ground, lower main boom until deck is just above ground, and swivel boom full aft. Then index the boom swivel "forward" function and determine the time required for the boom to swivel full forward.)



ASSEMBLY

(ASM-DF CALIBRATION SS-0001)

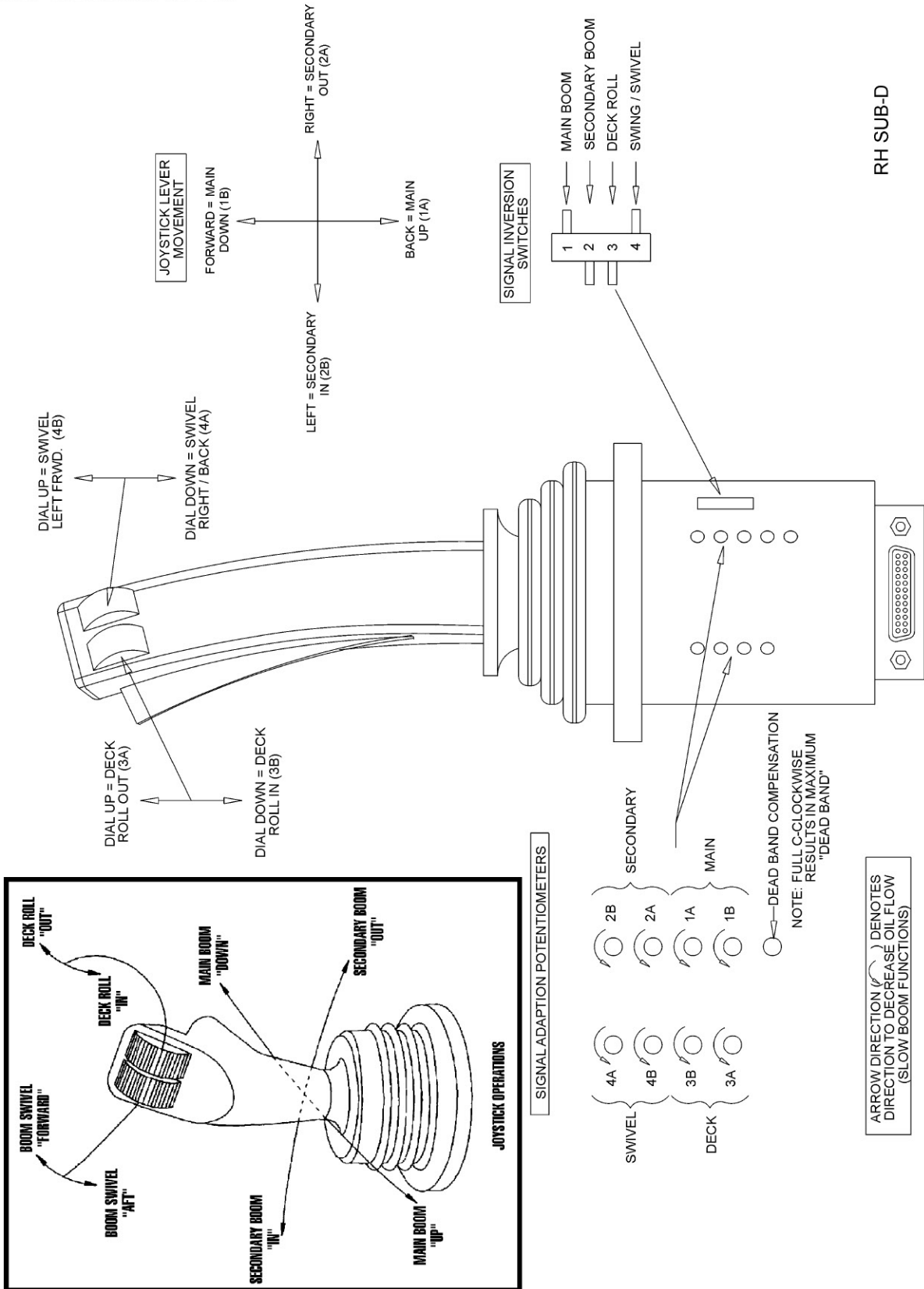

RH SUB-D



ASSEMBLY

BOOM JOYSTICK CONTROL CALIBRATION (FOR 3OS, 3PS) SUB-D

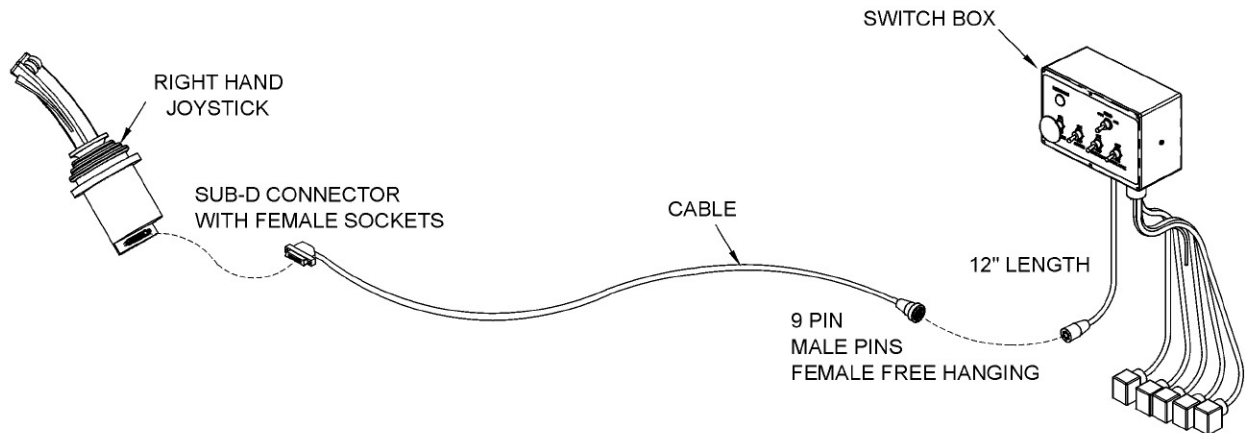

This Danfoss PVG32 control valve is now equipped with higher-resolution actuators on Main Boom, Secondary Boom, Deck Roll, and Swivel functions. These actuators have “active fault monitoring”. The Deck Shield section does not have “active fault monitoring”. The joystick is unchanged and provides a ratio-metric voltage signal. The neutral signal voltage is half or 50% of tractor supply voltage. A 25% signal voltage will shift the valve spool to full “A-Port”, and 75% signal voltage will shift the spool to full “B-Port” in the Main, Secondary, and Swivel valve sections. On the Deck Roll function a 34% signal voltage will shift the valve spool to full “A-Port” and a 68% signal voltage will shift the spool to full “B-port”. If an actuator with active fault monitoring receives a signal from the joystick that is less than 15% or greater than 85% of supply voltage the actuator will “fault out” and shut down. Also if there is an internal failure in the actuator or if the spool position is greater than that specified by the signal voltage from the joystick, the actuator will “fault out” and shut down. An “active fault” condition causes the actuator to drive the spool to neutral, shut down, and activate a “red” LED on the top of the actuator. The active fault can be canceled by simply cycling the Master Switch “OFF” and then “ON”, which resets the fault monitoring, and causes the LED on top of the actuator be “green” again..



The joystick control is equipped with signal adaption potentiometers.

These provide the capability to individually adjust the oil flow to each boom function. It is important that the boom functions do not travel too fast. Excessive boom speed can reduce the stability of the unit and decrease operator control.

Note: Use a Phillips screw driver and be sure to adjust the screws carefully! DO NOT turn the potentiometers beyond their stopping point, potentiometers are very delicate! Turning the “A” or “B” port potentiometers clockwise increases the oil flow to increase the boom function speed, and turning them counterclockwise decreases the oil flow to decrease the boom function speed. See the graphic on the next few pages for help in adjusting.



ASSEMBLY

Run tractor at normal operating RPM to adjust the settings as follows.

Set the dead band compensation potentiometer first.

Set the dead band compensation potentiometer at 50%, or halfway between full clockwise and full counter-clockwise.

Setting Signal Adaptation Potentiometers:

Disconnect the Deutsch connectors from the actuators of the valve. Use a Volt/Ohm meter to measure signal voltage and adjust the signal adaptation potentiometers as needed. Pin #4 is tractor supply voltage. Pin #1 is signal voltage from the joystick, and pin #3 is ground. First measure supply voltage between pins 4 and 3. Then measure signal voltage between pins 1 and 3 while indexing the joystick function fully in both the "A" and "B" port direction. Divide the signal voltage by the supply voltage to get signal voltage as a % of supply voltage. This percentage should not be less than 25% or greater than 75% for the Main Boom, Secondary Boom, or Swivel function. This percentage should not be less than 30% or greater than 62% for the Deck Roll function. Note these initial settings for the Deck Roll function should prevent the spool from shifting into float. *After making this first adjustment to deck roll if the spool still goes into float, adjust the "B" port screw additionally counterclockwise.*

Reconnect Deutsch connectors on control cables to actuators on Danfoss valve. Run tractor until hydraulic system is at operating temperature. Now refine the adjustments of the signal adaptation potentiometers for both "A" and "B" ports for all proportional functions to achieve the following function times. Note: turning potentiometer clockwise increases the flow or the function speed, and turning them counter-clockwise decreases the flow or the function speed. Note, if during this procedure the trim potentiometer is set to full "counterclockwise" but the function is still too fast, use the mechanical stops at the manual actuator end of the valve section to further limit flow. Turn limit screw in or clockwise to limit flow. The upper limit screw limits flow to "B-port", and the lower limit screw limits flow to "A-port". However DO NOT adjust the limit screw on "B-port" of deck roll function. Limiting "B-port" will prevent "float" function.



ASSEMBLY

MAIN BOOM: "A" Port, Boom UP: 7-9 Seconds

(Note: Extend secondary boom completely; roll deck to be level with ground, and lower main boom until deck is on ground. Now index main boom "up" function and determine the time required for main boom to rise completely.)

"B" Port, Boom Down: 6-8 Seconds

(Note: Extend secondary boom completely, roll deck to be level with ground, and raise the main boom to "full up". Then index the main boom "down" function to determine the amount of time required for the deck to contact the ground. CAUTION: Stop the boom just as the deck contacts the ground.)

SECONDARY

BOOM: "A" Port, Boom Out: 8-10 Seconds

(Position main boom full up, roll deck out until deck cylinder is fully retracted, and bring secondary boom in completely. Then index the secondary boom "out" function and determine the time required for boom to extend out completely.)

"B" Port, Boom In: 8-10 Seconds

(Position the main boom full up, roll deck out until deck cylinder is fully retracted, and extend secondary boom completely. Then index the secondary boom "in" function and determine the time required for boom to come in.)

DECK ROLL: "A" Port, Deck Out: 7-9 Seconds

(Raise main boom to vertical, extend secondary boom out slightly so that deck can be articulated without contacting the main boom, and roll deck in until deck cylinder is completely extended. Then index the deck roll "out" function and determine the time required for the deck to roll out.)

"B" Port, Deck In: Target 7-9 Seconds (but DO NOT use Limit Screw)

(Raise main boom to vertical, extend secondary boom out slightly so that deck can be articulated without contacting the main boom, and roll deck out until deck cylinder is completely retracted. Then index the deck roll "in" function and determine the time required for the deck to roll in.)

BOOM

SWIVEL:" A" Port, Boom Aft: 14-16 Seconds

(Extend booms completely; rotate head to be level with ground, lower main boom until deck is just above ground, and swivel boom full forward. Then index the boom swivel "aft" function and determine the time required for the boom to swivel aft. Use caution when doing this, stop boom before main boom contacts tire.)

"B" Port, Boom Forward: 14-16 Seconds

(Extend booms completely, rotate head to be level with ground, lower main boom until deck is just above ground, and swivel boom aft and until near tire. Then index the boom swivel "forward" function and determine the time required for the boom to swivel full forward.))



ASSEMBLY

(ASM-DF CALIBRATION 3OS 3PS-0001)

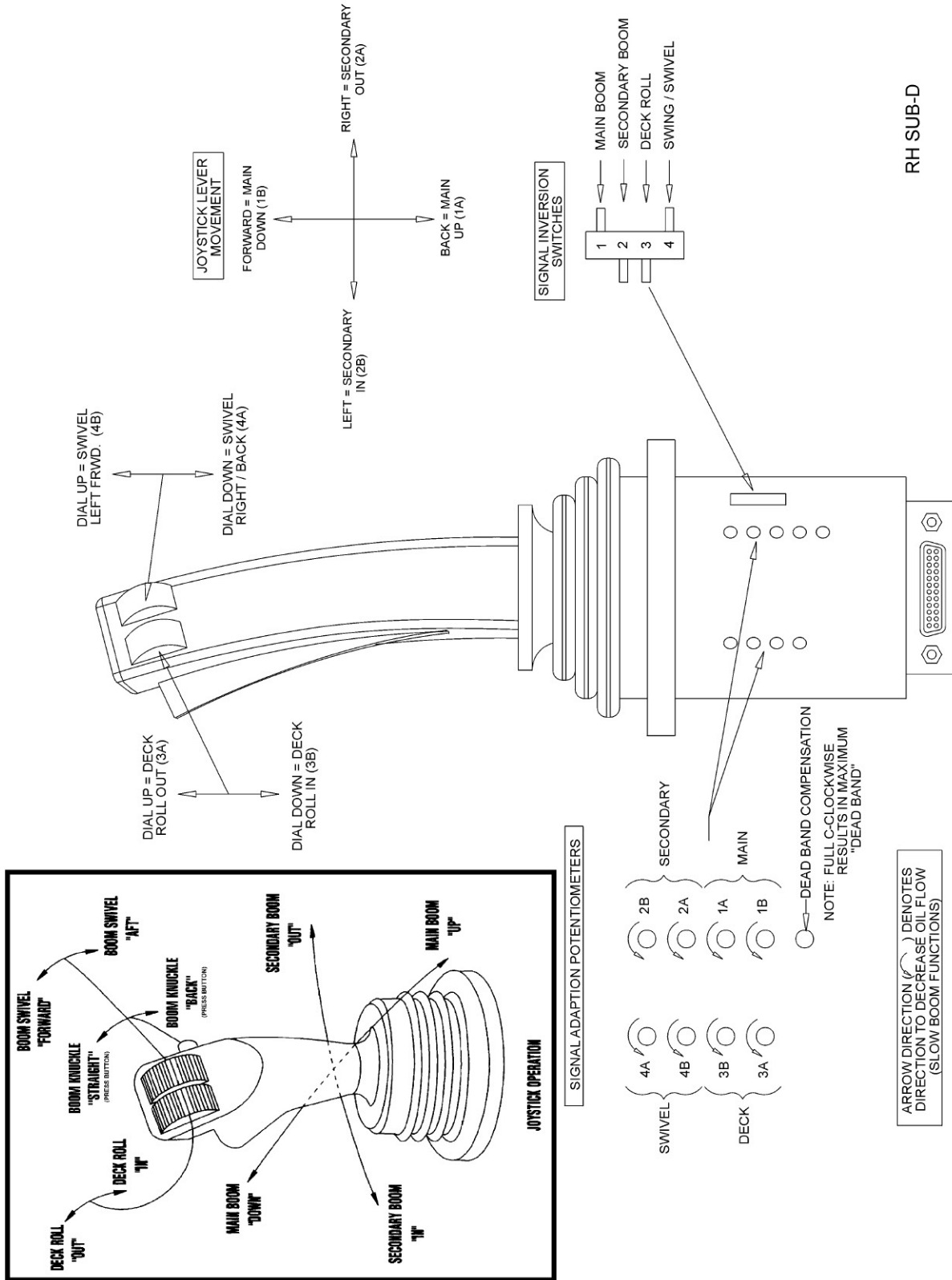

RH SUB-D



ASSEMBLY

FINAL PREPARATION FOR OPERATION

Place operators safety and operation decals on the steering column and side counsel where they are clearly visible to the operator. These decals should be understood by each operator of the machine in conjunction with the safety and operation section of this book. The decals are to be maintained in good condition as a reminder to the operator, and should be replaced if damaged.

Finally, all bosses, pins and pivot points will need to be greased as instructed in the maintenance section of this manual. The hydraulic reservoir can also be filled with the recommended fluid (see maintenance section) and the filter installed in the top of the tank. Double check all fittings and fasteners **BEFORE** starting tractor. Also secure any loose hoses together with zip ties and wrap with split hoses where friction may occur on the hoses.



BEFORE starting or operating the tractor you must read and understand the safety and operation sections of this manual completely.

BE SURE THE BALL VALVES ARE OPEN! Start tractor and allow instruments to stabilize. Using a piece of paper or cardboard as noted in the safety and maintenance sections, check all fittings and connections for hydraulic leaks.

If a leak is found, you must shut down the tractor, set the cutter on the ground. Before attempting to fix the leak, you must actuate the lift valve handles several times to relieve any pressure in the lines.

Before operating the mower, the cutter head and boom should be slowly moved throughout the full range of motion. Watch for any condition that would cause pinching or excess stress on the hoses. The steering and front axle travel should also be carefully moved through their full range of motion. If any condition occurs in which the hoses contact the tires, the steering and / or front axle travel may need to be limited as described in the tractor operators manual. This should also be done if the tires rub, or are extremely close to any other part of the mower such as the hydraulic tank or draft beam. This may include adding shims, or adjusting stop bolts in the tractor front to solve the problem. While checking motion, you should also check that the control circuits are connected according to the operators decal for the valve handles.

MOWER TESTING

Take the tractor to a place free of loose objects on the ground. Operate the cylinders through their full range of motion again, to clear the lines of air. Follow the instructions in the operation section to operate the mower. Vibration of the mower should be minimal at all times. After a 5 minute test run, the knife bolts should be retorqued and once again after the first few hours of operation.

If any parts of this assembly section, or any other section of this manual are not clearly understood you must contact your dealer or the address on the front of this manual for assistance!(ASM-C-0010)



ASSEMBLY



JD7X30 COUGAR

**OPERATION
SECTION**

OPERATION

Safety is of primary importance to the owner / operator and to the manufacturer. The first section of this manual includes a list of Safety Messages, that, if followed, will help protect the operator and bystanders from injury or death. Many of the messages will be repeated throughout the manual. The owner / operator / dealer should know these Safety Messages before assembly and be aware of the hazards of operating this mower during assembly, use, and maintenance.

The **Safety Alert Symbol** combined with a signal word, as seen below, is intended to warn the owner / operator of impending hazards and the degree of injury possible during operation.

CAUTION!



The lowest level of Safety Message; Warns of possible minor injury. Decals located on the cutter with this Signal Word are Black and Yellow.

WARNING!



Serious injury or possible death! Decals are Black and Orange.

DANGER!



Imminent death / critical injury. Decals are Red and White.

WARNING!



Many varied objects, such as wire, cable, rope, or chains, can become entangled in the operating parts of the mower head. These items could then swing outside the housing at greater velocities than the blades. Such a situation is extremely hazardous and could result in serious injury or even death. Inspect the cutting area for such objects before mowing. Remove any like object from the site. Never allow the cutting blades to contact such items. (SGM-6)

CAUTION!



Before any operation of tractor and mower, the user should read and understand the safety and operating instructions for both the tractor and the mower. The user should also be familiar with the location and functions of the units instruments and controls. Being familiar with the machine and it's controls will increase efficiency and reduce possibility of serious injury or damage to the unit. The operator should work slowly and carefully until he feels comfortable with the machine. Speed and skill will be attained much easier if the necessary time is spent to familiarize yourself with the machine and its operations.

Since tractor makes and models vary, we recommend reading and following the operators manual provided by the manufacturer pertaining to your particular unit.

WARNING!



Extreme care should be taken when operating near loose objects such as gravel, rocks, wire, and other debris. Inspect the area before mowing. Foreign objects should be removed from the site to prevent machine damage and/or bodily injury or even death. Any objects that cannot be removed must be clearly marked and carefully avoided by the operator. Stop mowing immediately if blades strike a foreign object. Repair all damage and make certain rotor or blade carrier is balanced before resuming mowing. (SGM-5)



OPERATION

STARTING TRACTOR AND MOWER

Check the operators manual received from the tractor manufacturer, for their recommendation and procedures pertaining to your particular make and model.

WARNING!



When rotating parts are in motion, serious injury may occur if caution is not used or danger is not recognized. Never allow bystanders within **300 feet** of the machine when mower is in operation.



Be sure the ball valves on the mower hydraulic tank are **OPEN** before starting the tractor. Serious damage to the hydraulic system can occur if the valves are not open.

WARNING!



Check to make sure mower switch is in the "**OFF**" position. The unit is designed not to start if the switch is in the "on" position. If tractor starts with switch on, turn off tractor and contact your local Tiger dealership for assistance.

Start the tractor and allow the instruments to stabilize. Without starting the mower, practice positioning the boom and deck. Remember, speed and skill will be attained easier if the necessary time is spent familiarizing yourself with the machine and its operations. When you feel comfortable at controlling the position of the mower, return the mower to the travel position, and transport the mower to the desired mowing location.

NOTE: Each mower head has a specific resting position for flatbed travel.

If mowing for the first time with a Tiger Boom Mower, we recommend choosing a ditch or area relatively flat with a minimum of sign posts, guard rails, etc. As always, you should inspect the area for other objects that can cause potential hazards and removing them before mowing.

The Mower Control switch turns the mower "ON" and "OFF. This switch is to be in the "OFF" position to start the tractor. If the switch is "ON" and the tractor ignition switch is turned to "ON" the red "mower run" indicator light will come on. However, the tractor will not start with the Mower Control switch in the "ON" position. Upon starting tractor the "mower run" indicator light may flash briefly, and may flash briefly again when tractor is shut down.

WARNING!



If tractor starts with switch on, turn off tractor and contact your local Tiger dealership for assistance.

NOTE: The tractor ignition switch and the Master Switch must be "ON" to allow movement of the mower deck.

OPERATION

CABLE CONTROLLED MOWERS

A control lever decal similar to the one shown below should be near the control valve to remind the operator of the lever functions.

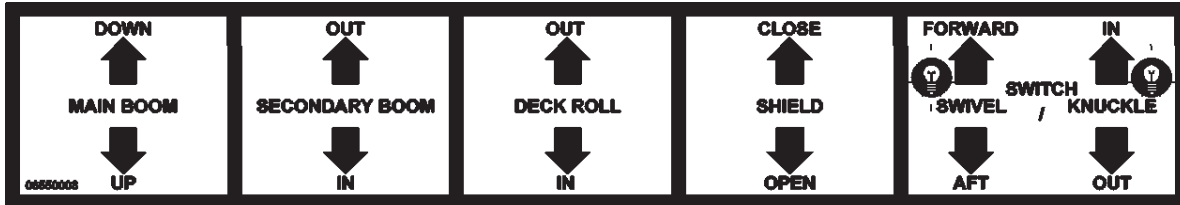

The main control valve on the Tiger Rear Stow Boom has multiple sections with tapered spools, located near the right side of the steering wheel. The malfunction of a section of the valve does not necessitate the replacement of the entire “bank”, only the faulty section. Each section of the valve controls a certain position of the boom or deck. Seated in the operators seat, the controls from left to right are #1 - primary(main) boom, #2 – secondary boom, #3 – deck roll, #4 – boom (swivel)swing & knuckle boom, and #5 boom(safety) shield.

Lever #4 is set up to be used for both the swivel function and the knuckle function. When using the knuckle, stop any movement of the boom. Then push the button on the end of Lever #4. At this time the indicator light on the switch box will light up, telling you the knuckle function is activated. You will then be able to straighten the knuckle and move it backward.

To switch back to the swivel function, stop any movement to the boom. Push the button on the end of Lever #4. The indicator light will shut off, letting you know that the swivel is now active.

NOTE: The mower head can still move if the switch box has no power.

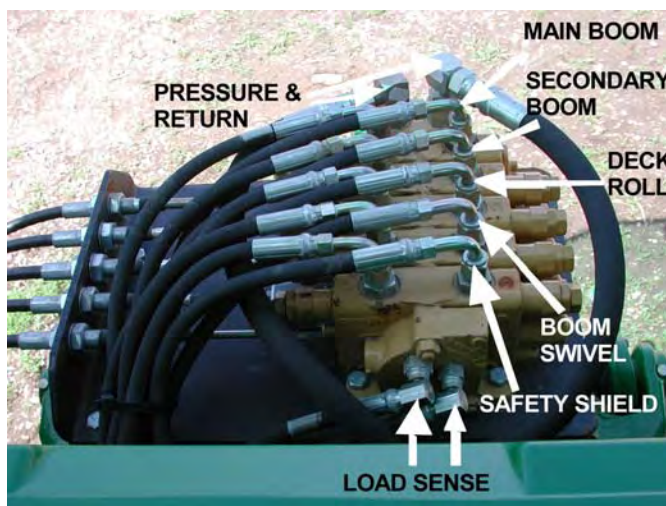

OPERATION

**LEVER #1
MAIN BOOM**

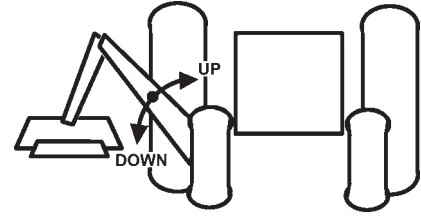

**LEVER #2
SECONDARY BOOM**

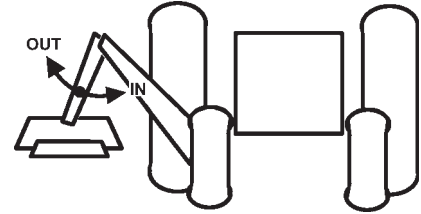

**LEVER #3
DECK ROLL**

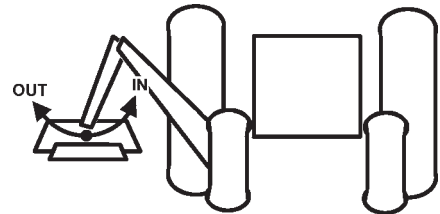

**LEVER #4
BOOM SWIVEL
INDICATOR LIGHT OFF**

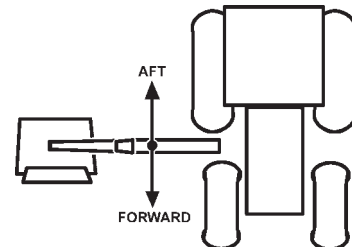

SWIVEL

**LEVER #4
WITH BUTTON PRESSED
BOOM KNUCKLE
INDICATOR LIGHT ON**

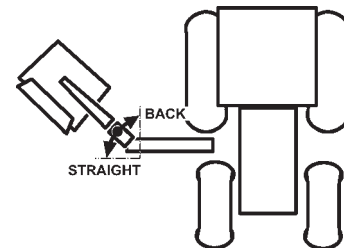

KNUCKLE

**LEVER # 5
BOOM SHIELD**

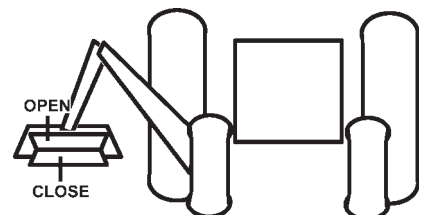

OPERATION

SWITCHBOX



The Safety Shield lever opens and closes the shield located on the front of the cutter head. When mowing at or near the ground, always have the shield in the closed position. When mowing in brush or in trees above ground level the shield may be opened for easier cutting. Read and follow the warnings on the decal shown below. **Do not run the cutter head into material larger than 6" diameter .**

DANGER

SAFETY SHIELD OPERATION

- **Failure to close Safety Shield may allow objects to be thrown outward with great force which can cause property damage, bodily injury, or death.**
1. **Keep Safety Shield fully closed when cutting grass and weeds to reduce possibility of objects being thrown outward by the Blades and to prevent contact with the Blades if persons are in the area.**
 2. **Before cutting brush, trimming limbs, or other such operations, raise Safety Shield fully to allow the blades to contact the material if area is clear of passersby. Operator must stop cutting and close shield if passerby enters the thrown objects area or blade contact area.**
 3. **Repair or replace Safety Shield as needed.**
 4. **Always transport with Safety Shield closed.**

OPERATION

MOWER OPERATION

WARNING!



When rotating parts are in motion, serious injury may occur if caution is not used or danger is not recognized. Never allow bystanders within **300 feet** of the machine when in operation. Extreme care should be taken when operating near loose objects – such as gravel, rocks and debris. These conditions should be avoided.

The rotating parts in this machine have been designed and tested for rugged use. However, they could fail upon impact with heavy solid objects – such as steel guard rails, concrete abutments, etc., causing them to be thrown at a very high velocity. Never allow cutter head to contact such objects. Inspecting the cutting area for such objects and removing them prior to mowing can help eliminate these potential hazards.

Once on location, lower the mower deck slightly above the material to be cut, so the mower does not have to start under a load. With the tractor at an idle, engage mower. Bring tractor R.P.M. up to 1900 – 2200 R.P.M. and **slowly** lower deck to ground level.

A flail mower deck should be carried so that part of the deck weight is carried by the boom and part carried by the ground roller, when mowing on the ground. When the flail mower is carried this way, the ground roller follows the contour of the ground more easily during mowing operations.

The rotary mower deck should always be carried rather than dragged on the skid shoes when mowing on the ground. Dragging the rotary mower deck increases the side loads on the boom, decreases the horsepower available to the cutter head, and reduces the ability of the accumulator to carry part of the weight of the boom during mowing operations.

During mower operation, the hand throttle must be used to maintain engine speed at 1900 – 2200 R.P.M. This prevents radical changes in mower spindle speeds, reducing the possibility of cutter assembly damage.

The horizontal positioning action of the boom is designed to position the cutting head and provide a limited pressure relief when excessive pressure is applied to the boom. Do not force the cutting head into heavy branches or stumps. Damage to the unit may result.

CAUTION!



When using the rotary cutting head for trimming trees and shrubs, let the mower saw into them. Do not lower the mower head down directly onto a tree or stump. The mower blades are designed to cut with the end, and misuse can cause damage to the blade and a hazardous situation for the operator.

CAUTION!



Powering the boom down, forcing mower deck onto ground may damage mower deck and it's attachment to the boom, creating a potentially hazardous situation.

OPERATION

To ensure a clean cut, engine speed should be maintained at approximately 1900 – 2200 R.P.M. If the tractor slows to less than 1800 R.P.M., shift to the next lower gear. **DO NOT** ride the clutch, this will cause premature clutch failure. **The engine should not be operated at any time at more than 2400 R.P.M. on the tractor tachometer.**

For cutting brush it is usually best to stop the tractor and swivel the boom and mower into foliage. The horizontal positioning action of the boom is designed to position the cutting head and provide a limited pressure relief when excessive pressure is applied to the boom.

CAUTION!



DO NOT use excessive force when positioning cutting head into heavy branches or stumps. Damage to the unit may result. It is best to let the cutter head “eat away” slowly at heavy cutting jobs.

CAUTION!



If foliage falls on top of mower deck causing tractor to become unstable, move the boom “Forward” and “Out” to relieve tipping of the tractor. Lower mower deck to ground and shut down unit. After all motion stops, remove foliage from mower deck.

The mower will operate more efficiently in tougher conditions and with less power if the knives are kept sharp. If the mower begins to vibrate, stop the tractor, check for wire wrapped in the spindle or damaged knives. When replacing knives, replace all knives with new knives to ensure proper balance so the mower will not vibrate. Severe vibration will result, if knives with unequal wear are used.

Begin a pass at the top side of the trees and work down with each consecutive pass. When cutting trees and shrubs, use a lower speed to allow the knives time to cut as well as mulch the foliage.

WARNING!



If bystanders approach within 300 feet while mower is in operation turn mower switch “OFF” immediately! After shutdown, never leave the tractor or allow bystanders to approach within **300 FEET** of the unit until all motion stops completely.

If cutter shaft jams and stops, turn mower switch to “OFF”, and swivel boom “AFT”. Normally this action will clear the cutter head. If not, roll mower deck until adjacent to the secondary boom, then lower boom to rest mower deck on ground. Shut off the tractor, set parking break, allow all motion to cease. At that point it is safe to leave the tractor and clear the cutter heads manually.

Begin each pass at the top side of the trees and work down with each consecutive pass. Use a low speed to allow the cutting blades time to mulch as well as cut the foliage. When the initial pass has been made, disengage the mower, and return boom to a safe travel position. Return to starting point and make next pass, etc..

After the first day of operation, all bolts should be checked and tightened securely. This should be done periodically to ensure the bolts do not become loose and cause damage to the tractor or mower, or injury to the operator.

OPERATION

DANFOSS JOYSTICK CONTROLLED MOWERS

WARNING!



NOTE: **DO NOT** operate mower head while boom mower is in the boom rest, or in the stored position! Red "Mower Run" light indicates mower is "ON".

The boom functions are controlled by an electronic joystick. The Joystick Master Switch enables the joystick control for controlling the boom motion functions. This switch is to be in the "OFF" position when starting the tractor and when boom is stowed for transporting the machine.

CAUTION!



If the joystick control is not operating properly, turn the master switch to the "OFF" position. Install the manual valve handle onto valve and operate the functions individually to stow boom. After boom is stowed in rest, transport the unit to the maintenance facility and contact your Tiger dealer for assistance.

CAUTION!



DO NOT attempt to operate the valve manually for mowing operations!

Note: Pushing manual valve handles "out" or "away" from the tractor cab will bring the main boom "up", secondary boom "out", roll deck "out", and swivel boom "aft". Pulling manual handles toward cab will let main boom "down", bring secondary boom "in", roll deck "in", and swivel boom "forward".

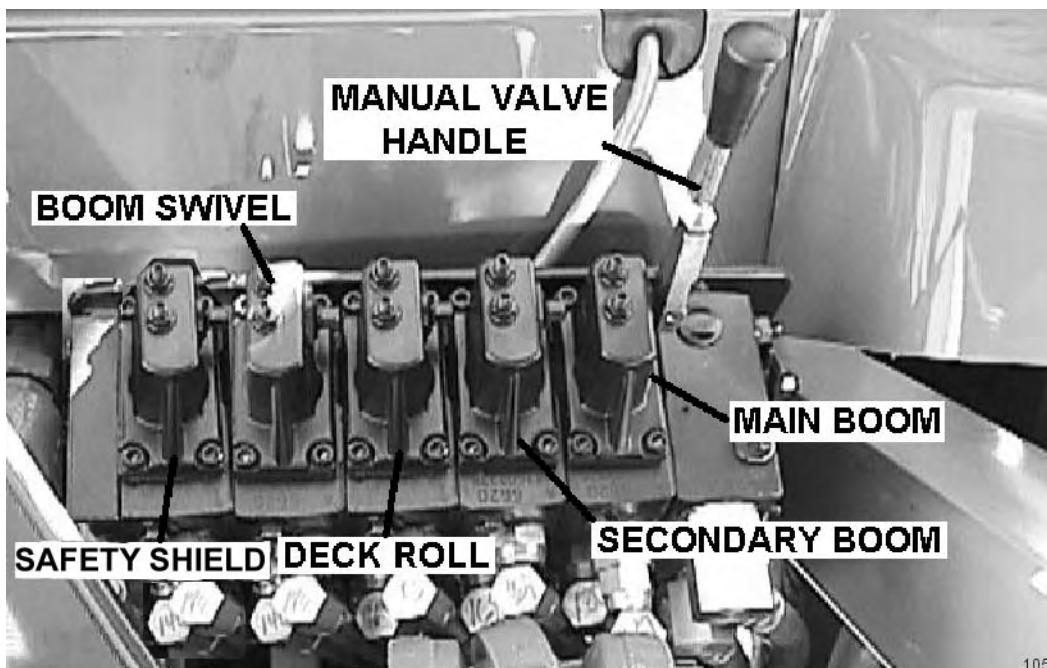

OPERATION

DANFOSS JOYSTICK CONTROL AND SWITCH BOX

The diagrams below and on the following pages show the functions that are performed through the use of the joystick controller.

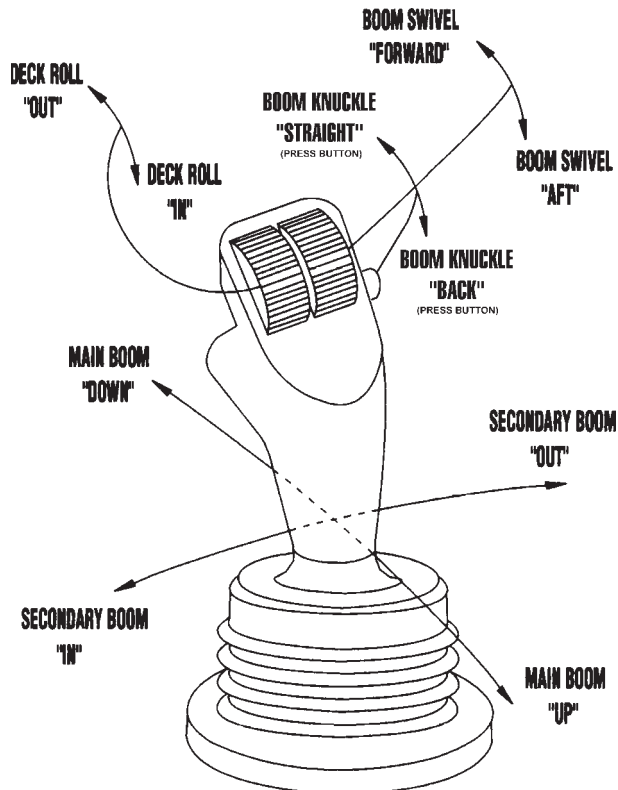
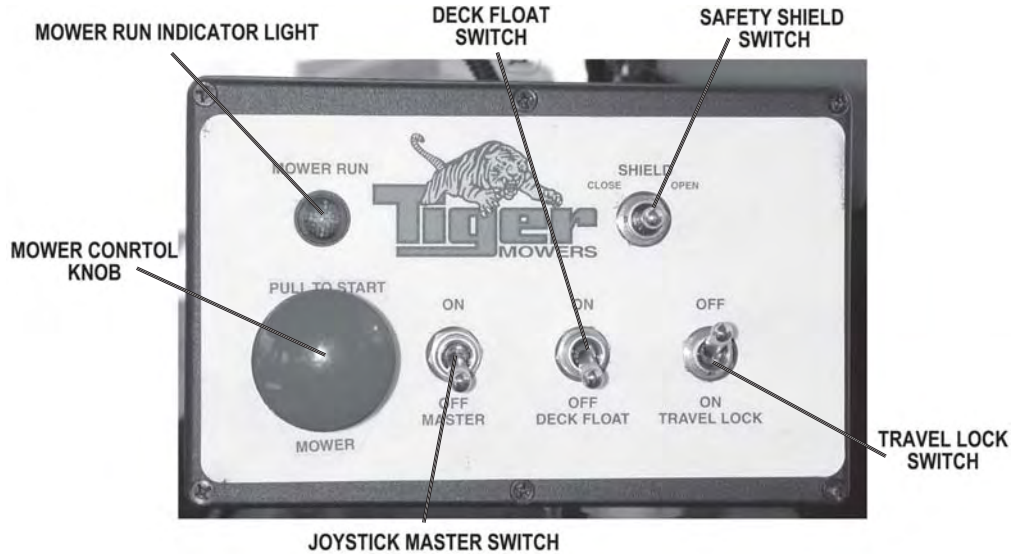

JOYSTICK OPERATION

OPERATION

**JOYSTICK FWD / BACK
MOVES MAIN BOOM**

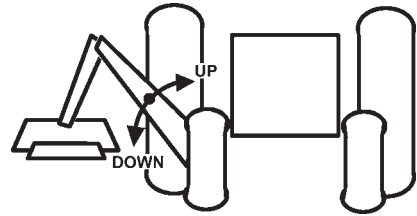

**JOYSTICK LEFT / RIGHT
MOVES SECONDARY BOOM**

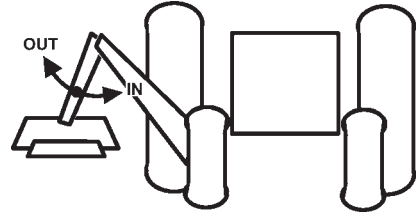

**LEFT JOYSTICK ROLLER
MOVES DECK ROLL**

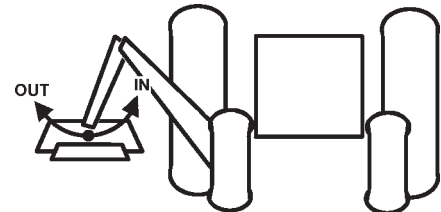

**RIGHT JOYSTICK ROLLER
MOVES BOOM SWIVEL**

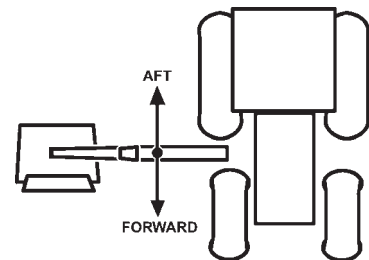

SWIVEL

**RIGHT JOYSTICK ROLLER
WITH BUTTON PRESSED
MOVES BOOM KNUCKLE**

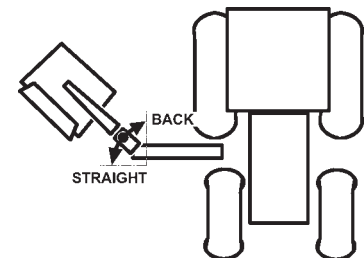

KNUCKLE

**SHIELD SWITCH
OPERATES SAFETY
SHIELD**

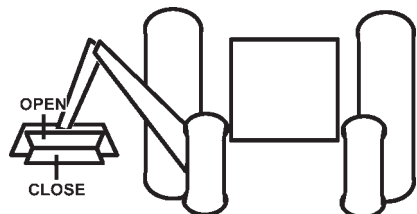

OPERATION

The Safety Shield switch opens and closes the shield located on the front of the cutter head. When mowing at or near the ground, always have the shield in the closed position. When mowing in brush or in trees above ground level the shield may be opened for easier cutting. Read and follow the warnings on the decal shown below. **Do not run the cutter head into material larger than 6" diameter .**



SAFETY SHIELD OPERATION

- **Failure to close Safety Shield may allow objects to be thrown outward with great force which can cause property damage, bodily injury, or death.**
- 1. **Keep Safety Shield fully closed when cutting grass and weeds to reduce possibility of objects being thrown outward by the Blades and to prevent contact with the Blades if persons are in the area.**
- 2. **Before cutting brush, trimming limbs, or other such operations, raise Safety Shield fully to allow the blades to contact the material if area is clear of passersby. Operator must stop cutting and close shield if passerby enters the thrown objects area or blade contact area.**
- 3. **Repair or replace Safety Shield as needed.**
- 4. **Always transport with Safety Shield closed.**

HEAVY DUTY ROTARY

The Heavy Duty Rotary mower was designed for cutting brush and foliage up to 6 inches in diameter or multiple branches that have a total cross section area equivalent to one 6 inch branch. Cutting multiple limbs at the same time may overload the mower causing it to slow down or stall completely. Regardless of the size of material being cut, the speed of the cutter head must be maintained. To ensure that the cutter head is running at maximum speed, run the tractor at full throttle during mowing operations. If the cutter head slows to the point that the knives are folding back, move the mower head away from the foliage and allow the cutter head to regain full speed.

OPERATION

WARNING!



Operating the mower in a manner that allows the cutting knives to continually fold back will cause permanent damage to the knives, rotary disk, and spindle assembly.

WARNING!



The Heavy Duty Rotary cutter head is designed for clockwise rotation (clockwise as seen from the top or the cutter head). **Never operate the cutter head in the counterclockwise rotation.** Operating this mower in counterclockwise rotation may cause objects to be thrown towards the tractor.

OPERATING DECK ROTATION WITH TRACTOR REMOTES

Orient the Mower Deck in a horizontal position before rotating mower deck. Push tractor remote valve lever forward to rotate deck counter - clockwise from stowed position to cutting position. Pull remote valve lever aft to rotate deck clockwise. Deck shall be rotated completely clockwise for stowing in the boom rest position.

UNSTOWING BOOM

To un-stow the boom from the boom rest, proceed as follows. Switch travel lock to "OFF". Move main boom "UP" to lift the secondary boom off of the boom support. Swivel boom "FORWARD" perpendicular to tractor. The head and booms are now ready for full operation.

TRANSPORTING MOWER

Transporting under the units own power:

NOTE: ONLY when transporting under the units own power is it permissible to rest the head in any of the resting positions. When transporting on a trailer the head MUST be resting on the position designed for the head you are using.

When transporting between job sites, the following procedure should be followed: Shut off the power to the cutting head and allow all motion to come to a complete stop. Roll the mower deck "OUT" all the way until it is adjacent to the secondary boom. Extend the secondary boom "OUT" to clear the boom rest. Next, swivel the boom "AFT" and maneuver the main boom until it rests on the boom rest. Switch over to the knuckle control and curl the knuckle "Back". Slowly and carefully lower the secondary boom until it contacts the desired cradle. Lastly, place the "Travel Lock" switch on the main control switch box to the "ON" position. The unit is now ready for self transportation. (See picture of stowed boom on next page).

OPERATION

JD 7X30 COUGAR

**MAINTENANCE
SECTION**

MAINTENANCE

Tiger Mowers are designed for high performance and rugged durability, yet with simplified maintenance. The purpose of this section of the manual is to help the operator in the regular servicing of the mower. Regular maintenance at the intervals mentioned will result in the maximum efficiency and long life of the Tiger Mower.

When you purchase a Tiger Mower you also acquire another valuable asset, Tiger's parts organization. Our rapid and efficient service has guaranteed the customer satisfaction for many years. Tiger parts keep up with the demands for efficiency, safety and endurance expected of the Tiger Mower.

MAINTENANCE PRECAUTIONS

- Be sure end of grease gun and zerks are clean before using. Debris injected into bearings, etc. with grease will cause immediate damage.
- DO NOT grease greaseless bearings. They can be identified by blackish/grey color. DO NOT use a power grease gun to lubricate bearings. These require very small and exact amounts of lubrication. Refer to the detailed maintenance section for specific lubrication instructions. DO NOT over-grease bearings.
- Polycarbonate windows should be washed with mild soap or detergent and luke warm water, using a soft clean sponge or **soft cloth**. DO NOT use abrasive or alkaline cleaners or metal scrapers on Polycarbonate windows!
- Be alert to maintenance indicators such as the in-tank filter pressure gauge, hydraulic reservoir sight gauge, etc. Take the required action to correct any problems immediately.
- Release of energy from pressurized systems may cause inadvertent actuation of cylinders, or sudden release of compressed springs. Before disconnecting any hoses relieve pressure by shutting tractor off, setting cutter on ground and actuating lift valve handles.

WARNING!



DO NOT use hands to check for suspected leaks in hydraulic hoses! Hydraulic fluid escaping under pressure can have sufficient force to penetrate skin and cause serious injury. If fluid is injected into skin, it must be surgically removed within a few hours or gangrene may result. Use a small piece of wood or cardboard, not hands, to search for pin hose leaks. Be sure all pressure is relieved whenever disconnecting lines. Be sure all connections are tight and hoses and lines are not damaged before applying pressure.

BREAK IN PERIOD

In addition to following the break in instructions for your particular tractor, the in-tank hydraulic fluid filter should be replaced after the first 50 hours of service. Thereafter the filter should be replaced every 500 hours, or yearly, whichever comes first.

Re-torque wheel lugs after first five hours of operation and periodically thereafter. See torque specifications listed in the tractor's service manual for your particular model. **Wheel lugs must always be re-torqued whenever a wheel is removed and reinstalled.**

MAINTENANCE

DANGER!



Never work under the Implement, the framework, or any lifted component unless the Implement is securely supported or blocked up to prevent sudden or inadvertent falling which could cause serious injury or even death. (SG-14)



WARNING!



Do not modify or alter this Implement. Do not permit anyone to modify or alter this Implement, any of its components or any Implement function. (SG-8)

WARNING!



Relieve hydraulic pressure prior to doing any maintenance or repair work on the Implement. Place the Mower Head on the ground or securely supported on blocks or stands, disengage the PTO, and turn off the engine. Push and pull the control Levers or Joystick several times to relieve pressure prior to starting any maintenance or repair work. (SBM-6)

DANGER!



Always disconnect the wire leads from the mower pump solenoid before performing service on the Tractor or Mower. Use caution when working on the Tractor or Mower. Tractor engine must be stopped before working on Mower or Tractor. The Mower Blades could inadvertently be turned on without warning and cause immediate dismemberment, injury or death. (SBM-12a)

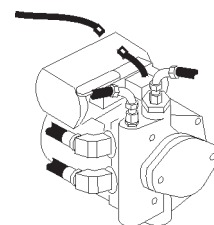

MAINTENANCE

REGULAR MAINTENANCE

The intervals at which regular servicing should be done are based on hours of operation. Use the tractors hour meter to determine when regular servicing is required.



This symbol indicates a point that needs to be greased at an interval noted in the section below. Refer to the Detailed Maintenance section for further instructions on greasing. Copy and use the Daily Maintenance sheet located at the end of this section.

DAILY OR EVERY 8 HOURS

ITEM	SERVICE	COMMENTS
Drive Shaft Yoke, U-Joint & Stub Shaft	Grease	Grease as instructed in detailed maint. section
Pump Drive Shaft Coupler	Check and Lube	Insure drive shaft end play
Crankshaft Adapter	Check rubber grommets	Replace grommets if damaged or missing
Main & Secondary Cylinder Pivot Points	Lubricate	Inject grease until it appears at ends
Hydraulic Fittings	Check for leaks	Tighten when needed. Do Not use hands to check for leaks, see maint. Precautions
Knives	Check	Inspect for missing or damaged knives, change or sharpen as needed
Spindle mounting bolts (spindle to deck)	Check	3/4" x 2" torque to 331 ft. lbs.
Knife mounting bolts (knife to disk)	Check	1-1/8" special bolt torque to 1070 dry or 800 oiled ft. lbs.
Disk mounting bolts (disk to spindle)	Check	5/8" x 1-3/4" bolt torque to 204 dry or 184 oiled ft. lbs.
Belts	Check / Adjust	Check if broken, tighten as required
Main Frame and Deck	Check	Retorque bolts to torque specifications in this section
Hydraulic Fluid Level	Check	Add if required per fluid recommendations
Rear Flail Drive (if applicable) Bearing Flange and Shaft Coupler	Lubricate	Grease as instructed in detailed maint. section
Cutter Shaft and Ground Roller Deck and Bonnet linkages	Lubricate	Grease as instructed in detailed maint. section

MAINTENANCE

WEEKLY OR EVERY 50 HOURS

ITEM	SERVICE	COMMENTS
In Tank Hyd. Fluid Filter (10 micron filter)	Change	Change after first 50 hours only, then every 500 hours or yearly
In-Line High Pressure Filter (10 micron filter)	Change	Change after first 50 hours only, then every 500 hours or yearly

MONTHLY OR EVERY 150 HOURS

Hydraulic Fluid Level	Check	Add as needed
Hyd. Tank Breather	Clean / Check / Replace	Clean or replace Element as required
Rear Tire Type	Max P.S.I.	
480/80R38	29	
18.4-34	26	
18.4-38	26	

YEARLY OR EVERY 500 HOURS

Spindle Grease	Change	
Hyd. Tank Fluid	Change	
In Tank Hyd. Fluid Filter (10 micron filter)	Change	
In-Line High Pressure Filter (10 micron filter)	Change	or Change when indicated by restriction indicator.
Hyd. Tank Breather	Change	

TROUBLESHOOTING

SYMPTOMS	CAUSE	REMEDY
Vibration	1. Loose bolts	1. Check all bolts and tighten to recommended torque specs.
	2. Cutter assembly Unbalanced	2a. Check for damaged blades, disc. or cutter shaft. Replace if needed. 2b. Check for wire, rope, etc. entangled in cutter assembly
Mower will not lift	1. Hyd. Fluid low	1. Check and refill Hyd Fluid
	2. Leaks in line	2. Tighten or replace fittings and hoses
	3. Faulty relief valve	3. Check pressure in line. Line pressure in Control Valve should be at least 2500 P.S.I.
	4. Kinked or blocked	4. Clean or replace lines
	5. Faulty cylinder	5. Inspect, repair or replace cylinder

MAINTENANCE

SYMPTOMS	CAUSE	REMEDY
Mower will not start or run	<ol style="list-style-type: none"> 1. Blown fuse 2. Ball valves closed 3. Low oil level 4. Line leak 5. Electronic solenoid faulty 	<ol style="list-style-type: none"> 1. Check fuse between mower switch and ignition / replace 2. Make sure valves are open 3. Check Hyd. tank and fill 4. Check all fittings and lines, re-tighten or replace 5a. Without the tractor running, turn the mower switch to on. A low audible click should be heard if the solenoid is engaging the solenoid spool. If click is not heard, leave switch in on position and with a screwdriver or other steel object, touch the small nut on the end of the solenoid. If the metallic object is not attracted to the nut, check the fuse and wiring for an open circuit. If the object is attracted but no "click" is heard, replace the solenoid. 5b. Remove the four bolts holding the small block to the main block. Lift and remove small block being careful not to damage O-rings / filter. Clean filter and re-install. 5c. Remove large nut on side of large valve block. Remove spring, and use needle nose vise grip to pull spool from block. Check block and spool for contaminants and scratches. Clean parts or replace if scratched.
Motor runs but will not cut.	<ol style="list-style-type: none"> 1. Belts 2. Tensioner 	<ol style="list-style-type: none"> 1. Inspect belts and pulleys. Replace belts and repair as needed. 2. Adjust tensioner nut until flat washer washer is flush with top of guide.
Motor turns slowly or not at all.	<ol style="list-style-type: none"> 1. Contaminants restricting spool movement in valve body. 2. Suction lines obstructed 3. Low oil level 	<ol style="list-style-type: none"> 1. Remove large nut on side of large valve block. Remove spring, and use needle nose vise grip to pull spool from block. Check block and spool for contaminants and scratches. Clean parts or replace if scratched. 2. Check for kinkes or obstruction in suction hose. 3. Check Hyd. tank level and fill.
Pump will not work	<ol style="list-style-type: none"> 1. Excessive wear on internal parts 	<ol style="list-style-type: none"> 1. Disassemble and repair.
Motor will not work	<ol style="list-style-type: none"> 1. Excessive wear on internal parts 	<ol style="list-style-type: none"> 1. Disassemble and repair.

MAINTENANCE

NOTE: If flow meter is available, check pressure and flow volume for all suspected hydraulic problems.

If the solution to your problem cannot be found in this section, call the Technical Service representative at the number shown on the front cover of this manual.

MAINTENANCE

TORQUE SPECIFICATIONS

Torque for Standard Fasteners													
Nominal Dia. (in.)	threads per inch	Grade 2			Grade 5			Grade 8			Grade 9		
		Tightening Torque			Tightening Torque			Tightening Torque			Tightening Torque		
		Lubed K = 0.15	Dry Plated K = 0.17	Dry plain K = 0.20	Lubed K = 0.15	Dry Plated K = 0.17	Dry plain K = 0.20	Lubed K = 0.15	Dry Plated K = 0.17	Dry plain K = 0.20	Lubed K = 0.15	Dry Plated K = 0.17	Dry plain K = 0.20
Unified Coarse Thread Series													
1/4	20	49 in-lbs	59 in-lbs	66 in-lbs	76 in-lbs	86 in-lbs	101 in-lbs	107 in-lbs	122 in-lbs	143 in-lbs	126 in-lbs	143 in-lbs	168 in-lbs
5/16	18	101	122	135	157	178	209	221	251	295	259	294	346
3/8	16	15 ft-lbs	18 ft-lbs	20 ft-lbs	23 ft-lbs	26 ft-lbs	31 ft-lbs	33 ft-lbs	37 ft-lbs	44 ft-lbs	38 ft-lbs	43 ft-lbs	51 ft-lbs
7/16	14	24	29	32	37	42	49	52	59	70	61	70	82
1/2	13	37	44	49	57	64	75	80	90	106	94	106	125
9/16	12	53	63	70	82	92	109	115	130	154	135	153	180
5/8	11	73	87	97	113	126	150	159	180	212	186	211	248
3/4	10	129	155	172	200	227	267	282	320	376	331	375	441
7/8	9	125	150	167	322	365	429	455	515	606	533	604	710
1	8	187	225	250	483	547	644	681	772	909	799	905	1065
1 1/8	7	266	319	354	596	675	794	966	1095	1288	1132	1283	1510
1 1/4	7	375	450	500	840	952	1121	1363	1545	1817	1597	1810	2130
1 1/2	6	652	783	869	1462	1657	1950	2371	2688	3162	2779	3150	3706
Fine Thread Series													
1/4	28	56 in-lbs	68 in-lbs	75 in-lbs	87 in-lbs	99 in-lbs	116 in-lbs	123 in-lbs	139 in-lbs	164 in-lbs	144 in-lbs	163 in-lbs	192 in-lbs
5/16	24	112	135	150	174	197	231	245	278	327	287	325	383
3/8	24	17 ft-lbs	20 ft-lbs	23 ft-lbs	26 ft-lbs	30 ft-lbs	35 ft-lbs	37 ft-lbs	42 ft-lbs	49 ft-lbs	43 ft-lbs	49 ft-lbs	58 ft-lbs
7/16	20	27	32	36	41	47	55	58	66	78	68	78	91
1/2	20	41	49	55	64	72	85	90	102	120	105	120	141
9/16	18	59	71	78	91	103	121	128	146	171	151	171	201
5/8	18	82	99	110	127	144	170	180	204	240	211	239	281
3/4	16	144	173	192	223	253	297	315	357	420	369	418	492
7/8	14	138	165	184	355	403	474	502	568	669	588	666	784
1	14	210	252	280	542	614	722	765	867	1020	896	1016	1195
1 1/8	12	298	357	397	668	757	890	1083	1227	1444	1269	1439	1693
1 1/4	12	415	498	553	930	1055	1241	1509	1710	2012	1768	2004	2358
1 1/2	12	734	880	978	1645	1865	2194	2668	3024	3557	3127	3544	4169

Torque values for 1/4 and 5/16-in series are in inch-pounds. All other torque values are in foot-pounds. K = 0.15 for "lubricated" conditions D = Nominal Diameter
 Torque values calculated from formula T=KDF, where K = 0.17 for zinc plated and dry conditions F = Clamp Load
 K = 0.20 for plain and dry conditions

Torque-Tension Relationship for Metric Fasteners													
Nominal Dia. (mm)	Pitch	Class 4.6			Class 8.8			Class 10.9			Class 12.9		
		Tightening Torque			Tightening Torque			Tightening Torque			Tightening Torque		
		Lubed K = 0.15	Dry Plated K = 0.17	Dry plain K = 0.20	Lubed K = 0.15	Dry Plated K = 0.17	Dry plain K = 0.20	Lubed K = 0.15	Dry Plated K = 0.17	Dry plain K = 0.20	Lubed K = 0.15	Dry Plated K = 0.17	Dry plain K = 0.20
3	0.5	0.26	0.32	0.38	0.73	0.82	0.97	1.0	1.2	1.4	1.2	1.6	
3.5	0.6	0.44	0.50	0.59	1.1	1.3	1.5	1.6	1.9	2.2	1.9	2.5	
4	0.7	0.66	0.74	0.87	1.7	1.9	2.3	2.4	2.7	3.2	2.8	3.8	
5	0.8	1.3	1.5	1.8	3.4	3.9	4.5	4.9	5.5	6.5	5.7	7.6	
6	1	2.3	2.6	3.0	5.8	6.6	7.7	8.3	9.4	11	9.7	13	
6	1.25	2.1	2.3	2.7	5.3	6.0	7.0	7.6	8.6	10	8.8	12	
7	1	3.8	4.3	5.0	9.7	11	13	14	16	19	16	22	
8	1	5.9	6.6	7.8	15	17	20	22	24	29	25	34	
8	1.25	5.5	6.2	7.3	14	16	19	20	23	27	24	31	
10	1.25	11	13	15	29	33	39	42	48	56	49	66	
10	1.5	11	12	14	28	32	37	40	45	53	47	62	
12	1.25	21	23	28	53	60	71	76	86	101	89	119	
12	1.5	20	22	26	51	58	68	73	82	97	85	113	
12	1.75	19	21	25	49	55	65	70	79	93	81	108	
14	1.25	26	29	34	66	75	89	95	108	127	111	148	
14	1.5	28	32	37	72	82	96	103	117	138	121	161	
14	2	30	34	40	78	88	104	111	126	148	130	173	
16	1.5	50	57	67	129	146	171	184	208	245	215	287	
16	2	47	53	62	121	137	161	173	196	230	202	269	
18	1.5	73	82	97	187	212	249	268	303	357	313	417	
18	2.5	65	73	86	167	189	222	239	270	318	279	372	
20	2.5	91	104	122	236	267	314	337	382	449	394	525	

Clamp load calculated as 75% of the proof load for specified bolts. K = 0.15 for "lubricated" conditions D = Nominal Diameter
 All torque values are listed in foot-pounds K = 0.17 for zinc plated, dry conditions F = Clamp Load
 Torque values calculated from formula T=KDF, where K = 0.20 for plain and dry conditions

* These are intended to be general specifications. See tractor operators or service manual for exact specifications for your unit.

MAINTENANCE

LUBRICATION RECOMMENDATIONS

Description	Application	General Specification	Recommended Mobil Lubricant
Tractor Hydraulics	Reservoir	JD-20C MF M1135,M1141 FNHM2C134D (FNH201)	Mobilfluid 424
Mower Hydraulics	Reservoir		
Cold Temperatures 0 F Start-Up		ISO 46 Anti-Wear - Low Temp	Mobil DTE 15M
Normal Temperatures 10 F Start-Up		JD-20C MF M1135,M1141 FNH M2C134D (FNH201)	Mobilfluid 424
Normal Temperatures 15 F Start-Up		ISO 46 Anti-Wear	Mobil DTE 25
High Operating Temp. Above 90 F		ISO 100 Anti-Wear	Mobil DTE 18M
Flail Rear Gearbox	Grease	PAO Synthetic Extreme Pressure Gear Lube	Mobil SHC 75W-90 Mobil 1 Synthetic Gear
Cutter Shaft & Ground	Grease	Lithium-Complex	Mobilgrease CM-S
Roller Shaft (Flail)	Gun	Extreme Pressure NLGI 2 - ISO 320	
Drive Shaft Coupler (Flail and Rotary)	Grease Gun	Lithium-Complex Extreme Pressure NLGI2 - ISO 320	Mobilgrease CM-S
Drive Shaft Yoke, U-Joint & Stub Shaft	Grease	Lithium-Complex	Mobilgrease CM-S
Deck rotation linkages	Gun	Extreme Pressure NLGI 2 - ISO 320	
Boom Swivel	Grease	Lithium-Complex	Mobilgrease CM-S
Boom Cylinder Pivots (Rotary & Flail Boom)	Gun	Extreme pressure NLGI2 - ISO 320	
Deck Boom Pivot & Deck Stop Adjustment (Rotary & Flail)	Grease Gun	Lithium-Complex Extreme pressure NLGI 2 - ISO 320	Mobilgrease CM-S
Deck Spindle (Rotary)	Grease Gun	Tiger Spindle Lubricant part number 06540000	Mobilith SHC 220

MAINTENANCE

RECOMMENDED FILLING INSTRUCTIONS FOR HYDRAULIC RESERVIORS

When filling or checking the oil level, the unit should be parked on a level surface, shut "OFF", and allowed sufficient time to cool to ambient temperature. Use caution when removing the pressurized breather. Do not place face over opening when removing the breather.

The reservoir should be filled to the top of the lower sight glass on the side of the tank. Do not over-fill. The reservoir has been over-filled when oil is visible in the upper sight glass. If tank has too much oil, the excess may be expelled through the pressurized breather.

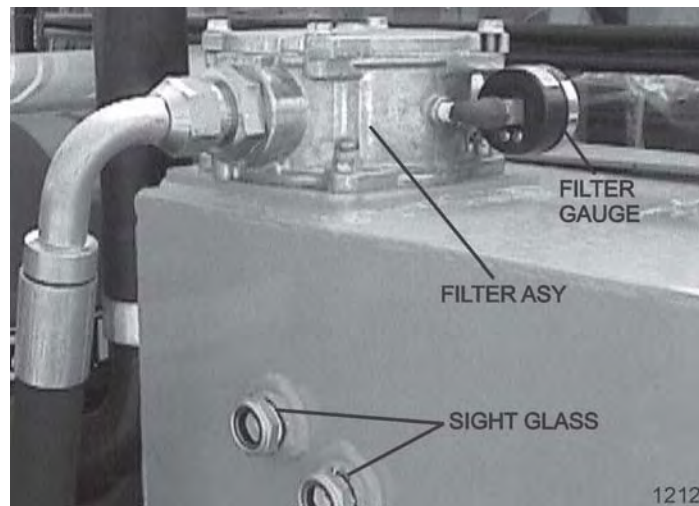

DETAILED MAINTENANCE

REPLACEING IN-TANK HYDRAULIC FILTER:

Loosen the four bolts on the top cover of the filter housing. Turn cover counter-clockwise until cover is free. Remove and replace filter. Replace top cover and cover bolts in opposite order as removed.

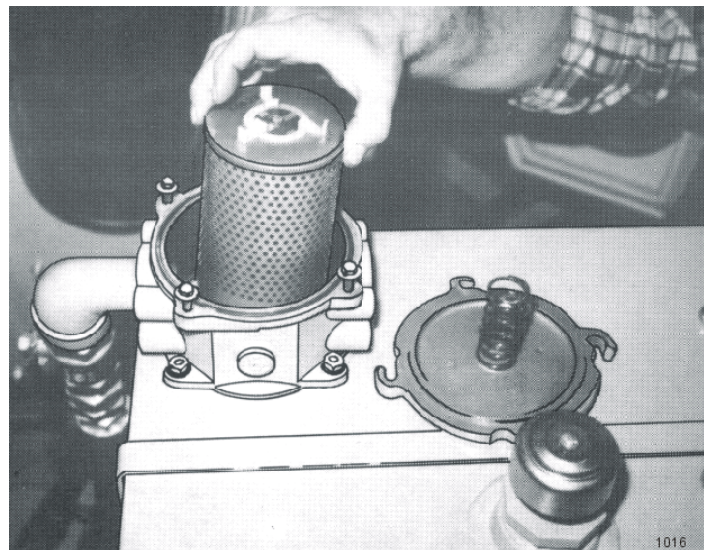

MAINTENANCE

DETAILED MAINTENANCE

REPLACING HIGH PRESSURE HYDRAULIC FILTER ELEMENT:

Assure system has been shut down and de-pressurized. Locate High Pressure Filter housing. Confirm that the element that is about to be installed matches the element p/n on the filter model tag. Example: V3.0510-06 (world line 100, HD049 model) Locate the bottom of the High Pressure Bowl, and use the appropriate spanner wrench –or- ratchet that matches the hex pattern. Using the spanner wrench -or- ratchet and turning in a counterclockwise rotation, (looking at the bottom of the bowl) remove the bowl from the head, The first couple rotations will seam tight as the o-ring passes the sealing flats, once the o-ring has cleared the sealing flats the bowl should spin freely. Taking care not to drop the bowl, finish removing the bowl from the head. **WARNING:** bowl will be full of oil! Pour the oil from the bowl into a container, this oil should be considered contaminated due to the flow direction through the element is outside ~ in. Clean the inside of the bowl if “dirt” is present. Remove the old element from the filter head by pulling with a rotation motion. Dispose of the used element properly. Remove the new element from the packaging. Using your finger, dab and lubricate the o-ring in the top of the new element. Install the new element into and on the mounting boss with in the head; assure that the element is fully seated on the boss. Clean and inspect the o-ring that is affixed in the bowl, lubricate with oil. Using a clockwise rotation, screw the bowl back into the head, assuring that the bowl has not been cross threaded into the head. Continue “tighten” the bowl into the head, using the spanner wrench –or- ratchet, the rotation of the bowl will become tighter once the o-ring engages the sealing flats. Once the bowl has been fully inserted into the head, and the o-ring has reached the sealing flats, the bowl can no longer be “tightened” and bottoms out. Once the bowl has bottomed out, “back-off” the bowl by 1/6 turn, this assures that the o-ring is seated properly with in the sealing flats. Element change out and re-assembly is now complete. Start the machine and inspect the filter area checking that there is no oil leaking from the filter assembly. This is first to be done at 50 hours of operation, then yearly(500 hours) or when indicated by restriction indicator.

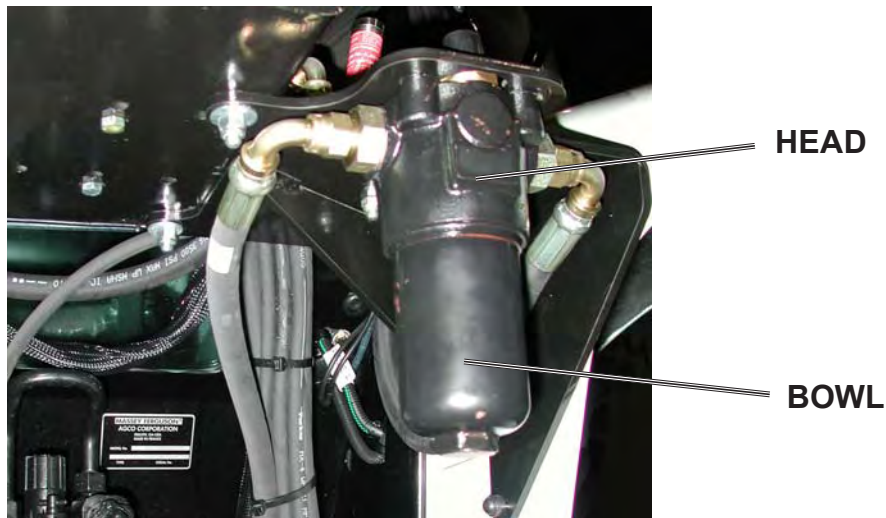

MAINTENANCE

GREASING CUTTER SHAFT – FLAIL MOWERS

Locate grease zerks on each end of cutter shaft(s), these are located on the bearing cover. Normal conditions require one or two pump in each bearing, using Lithium-Complex Extreme Pressure grease conforming to NLGI2-ISO 320 specifications. This is to be done with a standard grease gun daily or at **8 hour intervals**.

CAUTION: Over greasing may cause premature seal failure.



GREASING GROUND ROLLER SHAFT – FLAIL

Locate grease zerks on each end of roller tube at lower rear of head. Normal conditions require one or two pump in each bearing, using Lithium-Complex Extreme Pressure grease conforming to NLGI2-ISO 320 specifications. This is to be done with a standard grease gun daily or at **8 hour intervals**.

CAUTION: Over greasing may cause premature seal failure.

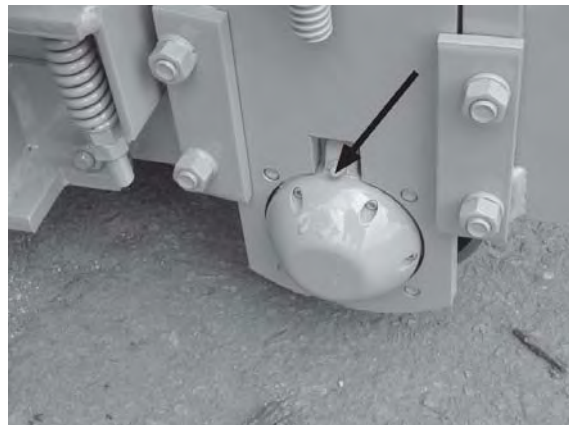

MAINTENANCE

GREASING PUMP DRIVE SHAFT COUPLER

With engine stopped, ensure drive shaft alignment by grasping coupler and sliding back and forth. Coupler should slide freely with approximately 1/8" of end play. If coupler does not slide freely, inspect for loose pump mount bolts, or damaged or loose crank shaft adapter. Inject Lithium-Complex Extreme Pressure grease conforming to NLGI2-ISO 320 specifications into coupler until grease begins to protrude from ends. Grease daily or every 8 hours. **Do not over grease.**

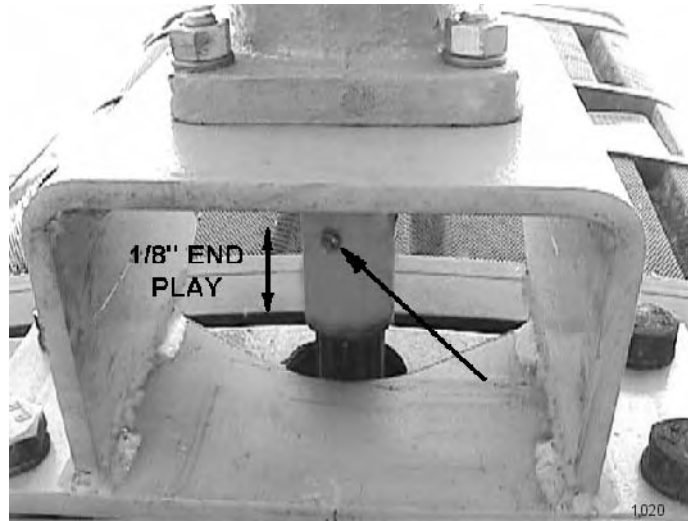

DRIVE SHAFT YOKE, U-JOINT & STUB SHAFT

With engine stopped, inject Lithium-Complex extreme pressure grease conforming to NLGI2-ISO 320 specifications into universal joints and slip yoke until grease appears at the seal. Grease them daily or every 8 hours .

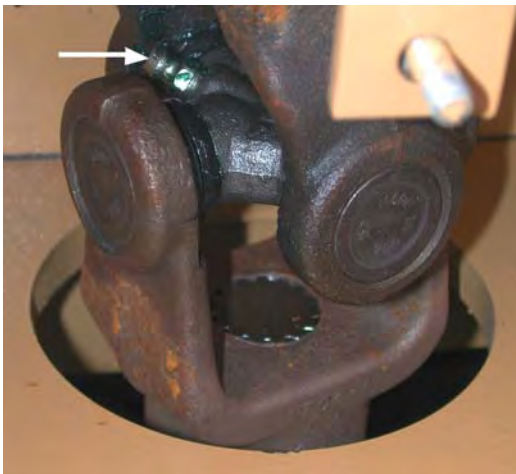

MAINTENANCE

VISUAL MAP OF GREASE POINTS

Please read the specific instructions for each area.

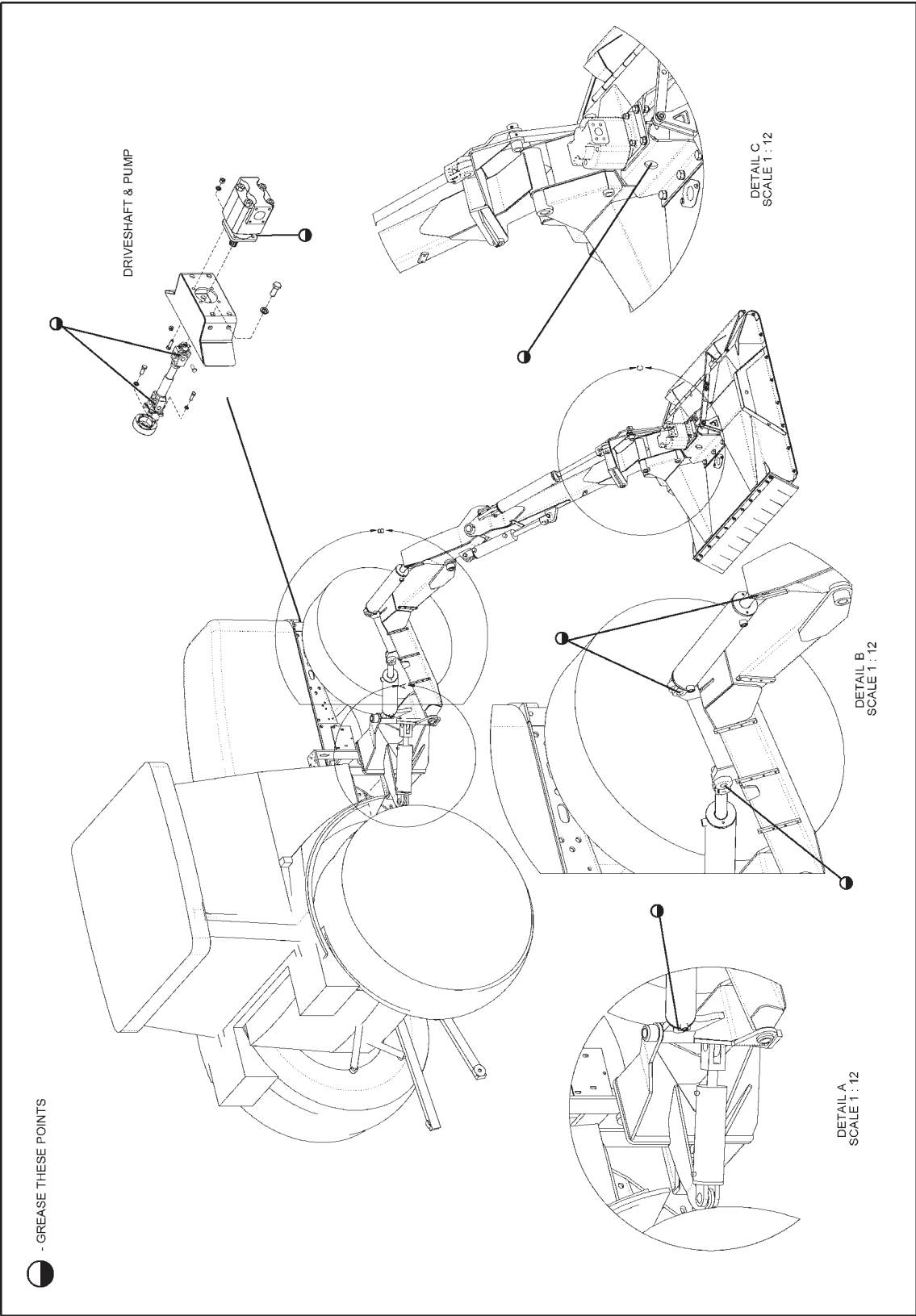

MAINTENANCE

GREASELESS BEARINGS ON THE BOOM

The pivot points on the boom have greaseless bearings. Check the guide on the last page for greasing points.

NOTE: The new greaseless bearing is blackish/gray in color and should not be greased.

GREASING BOOM CYLINDERS

Locate the zerk on the butt end tang and on rod end tang of the main and secondary boom cylinder. Inject Lithium-Complex Extreme Pressure grease conforming to NLG12-ISO 320 specifications until grease begins to protrude from ends. This procedure is to be performed daily or at 8 hour intervals.

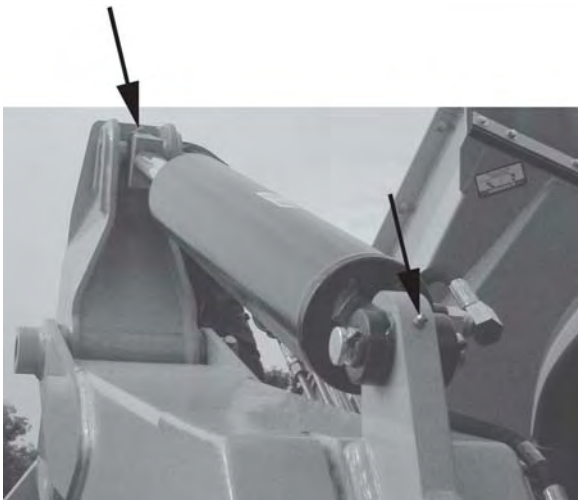

GREASING SPINDLE

Locate grease fitting on inside of deck housing. Inject Tiger Spindle Lubricant, part number 06540000 into spindle housing. Fill with lubricant until lubricant weeps out of top spindle seal. Lubricate spindle at end of day while mower is still warm.

GREASING DECK ROTATION LINKAGE

Locate grease zerks on linkages. Inject Lithium-Complex Extreme Pressure grease conforming to NLG12-ISO 320 specifications.. Fill with lubricant until lubricant weeps out of pin locations. Lubricate daily.

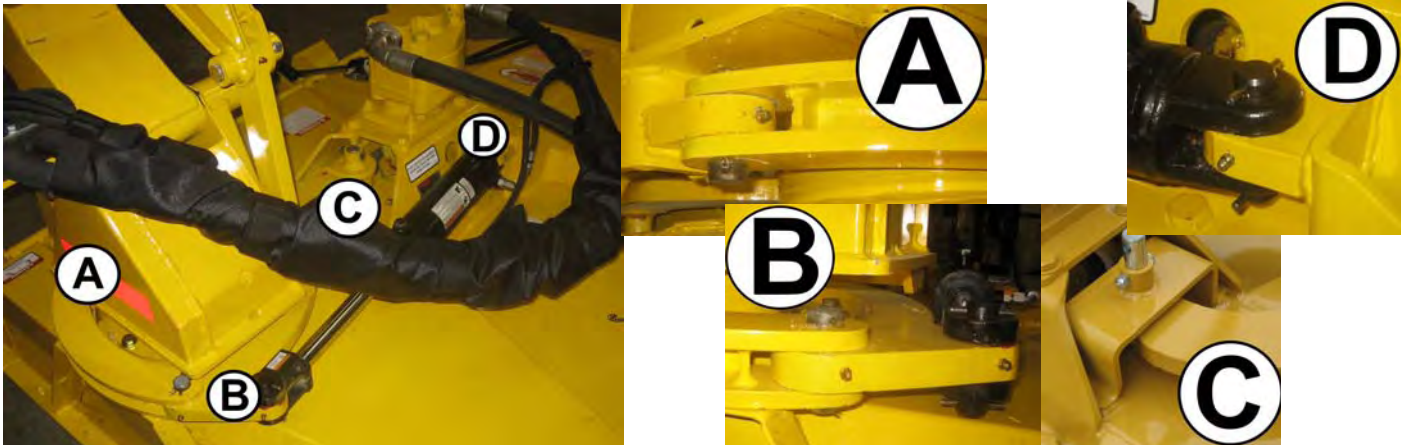

MAINTENANCE

ADJUSTING / CHECKING BELT TENSION

To adjust belt tension or replace belts on flail cutter head, remove four bolts that secure belt cover and remove cover. The hex nuts shown below can be adjusted to increase / decrease the belt tension as needed. (NOTE: Location of adjustment nuts may vary on flail cutter heads.) **Be sure to replace the belt cover BEFORE operating mower!**

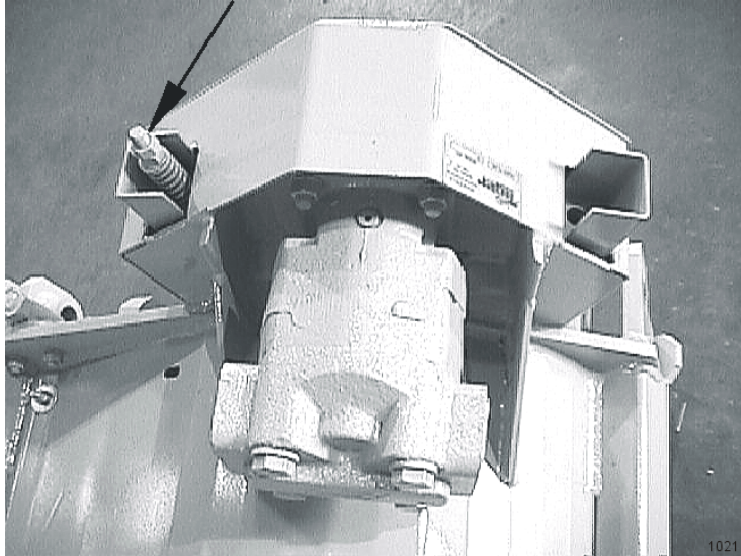

DECK STOP ADJUSTMENT

Loosen locking nut. Turn adjustment bolt in, and run deck cylinder out to full extension. Adjust bolt out until the head just touches the boom, and tighten lock nut. **NOTE: Bolt should not hit boom before cylinder reaches full travel.**



MAINTENANCE

TIGHTENING KNIFE BOLTS AND DISK BOLTS:

After every 8 hours of operation or daily, the Knife Bolts and Disk Bolts should be tightened as follows:

Knife mounting bolts (3ea.) torque to 1070 dry or 800 oiled ft. lbs.(Recomended oiled)

Disk mounting bolts (6ea.) torque to 204 dry or 184 oiled ft. lbs.(Recomended oiled)



TIGHTENING SPINDLE BOLTS

The spindle mounting bolts should be checked and retorqued daily or every 10 hours of service. Torque the (6) bolts shown below to 331 ft. lbs.

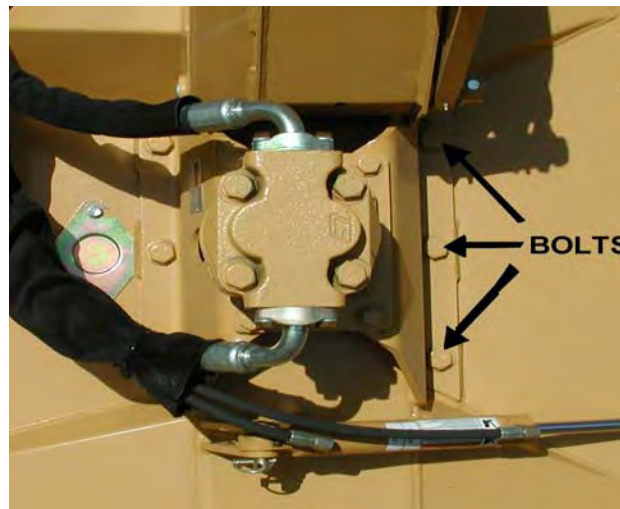

MAINTENANCE

BALL VALVES

The ball valve at the hydraulic reservoir may need to be closed during certain maintenance or repair procedures. **THE BALL VALVES MUST BE OPEN (handle parallel with valve) WHEN TRACT OR IS RE-STARTED OR PUMP IS COUPLED TO MOTOR OR P.T.O. !** Failure to do so will result in component failure!

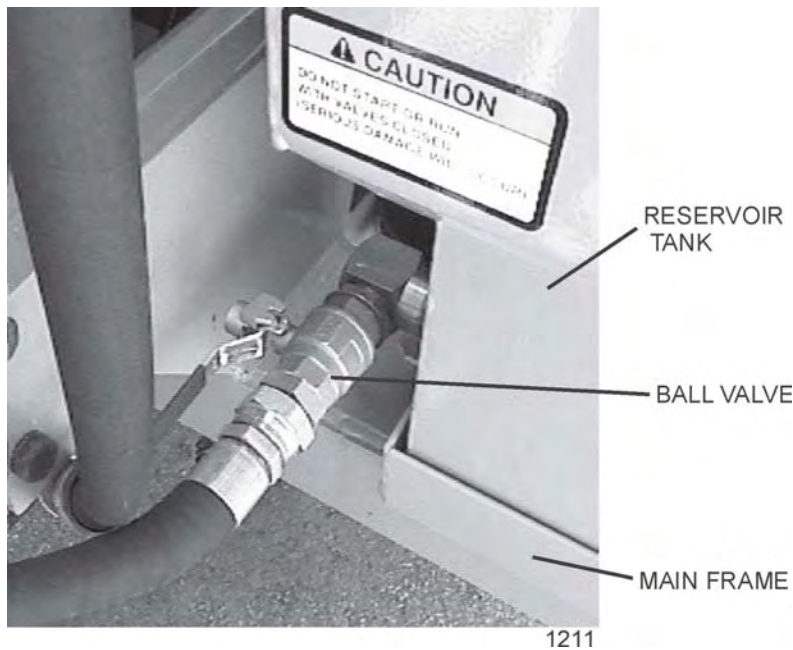

MAINTENANCE

INSPECTION OF ROTARY KNIFE

CAUTION!



Failure to follow the following warnings and instructions may result in serious injury or damage to the equipment or property!

- 1 – **DO NOT** weld on the knives or bolts. Damaged or worn knives must be replaced.
- 2 – Knives must be replaced in sets. **Knives with unequal wear may cause serious vibration and resulting structural damage to the mower .**
- 3 – The self-locking nuts for the knife mounting bolts must **NOT** be reused. If the self-locking nut is removed from the knife mounting bolt, the nut **must** be replaced with a new self-locking nut.
- 4 – Inspect the condition and tightness of the knife mounting bolts and disk mounting bolts daily.

ROTARY KNIFE REPLACEMENT

- 1 – Be sure you have a complete matching set of new knives for replacement.
- 2 – Remove knives and inspect holes for damage. Also watch for cracks in the disk around the holes.
- 3 – Install bolt through knife and disk from bottom side of disk. Install new self-locking nuts and torque them to 1070 dry or 800 oiled ft. lbs. It is recommended that they are oiled.
- 4 – The knives should swing freely to absorb shocks from impact when striking objects.

WARNING!



WHEN CUTTING HEAVY BRUSH, KNIFE BOLTS SHOULD BE INSPECTED HOURLY AND RETORQUED TO 1070 DRY OR 800 OILED FT. LBS.

MAINTENANCE

HEAVY DUTY SPINDLE ASSEMBLY INSTALLATION AND BEARING ADJUSTMENT

WARNING! A press MUST be used to install bearing cups, bearing cones, and seals. DO NOT use a hammer to install races, bearings, or seals. The parts of assembly may be damaged.

NOTE: The grease zerk and gussets are located on the top side of the spindle housing. Be sure the spindle is assembled correctly.

Be sure to wear eye protection and other protective equipment as needed when working on spindle assembly.

THE SPINDLE ASSEMBLY

See the diagram below for identification of spindle parts, while servicing.

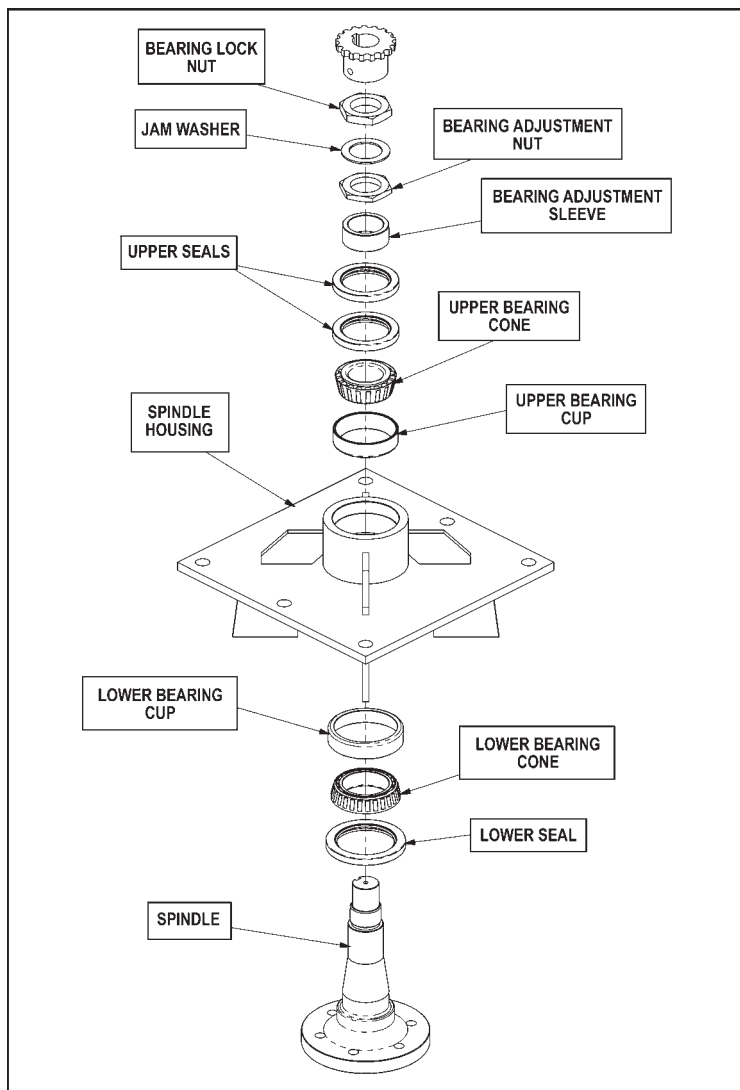

MAINTENANCE

BEARING INSTALLATION

- 1 – Press upper bearing cup into the spindle housing.
 - 2 – Turn the spindle housing over and press in the lower bearing cup.
 - 3 – Place the lower bearing cone in the bearing cup. Next press the seal into the spindle housing. The inner lip of the seal must be DOWN, towards the bearing, so lubricant is sealed inside the housing.
 - 4 – Install the spindle in the housing. Lightly tap the end of the spindle with a soft faced hammer to seat the spindle against the bearing inner race.
 - 5 – Turn the spindle housing over (up position) and fill with Tiger Spindle Lubricant (part number 06540000) to the top edge of the upper bearing cup.
 - 6 – Support the bottom of the spindle and press the upper bearing cone and bearing adjustment sleeve onto the spindle.
- NOTE: The spindle housing must turn freely when seating the bearing cone and sleeve.
- 7 – Press the two upper seals into the spindle housing. The inner lip of the seals must be UP, away from the bearing, so excess lubricant can escape.
 - 8 – Install the bearing adjustment nut (thin nut) so there is 1/16" clearance between the nut and the sleeve. Install the jam washer, placing the tab into the key-way. Install the bearing lock nut (thin nut) and hand tighten against jam washer and adjustment nut. See the following section for bearing adjustment.

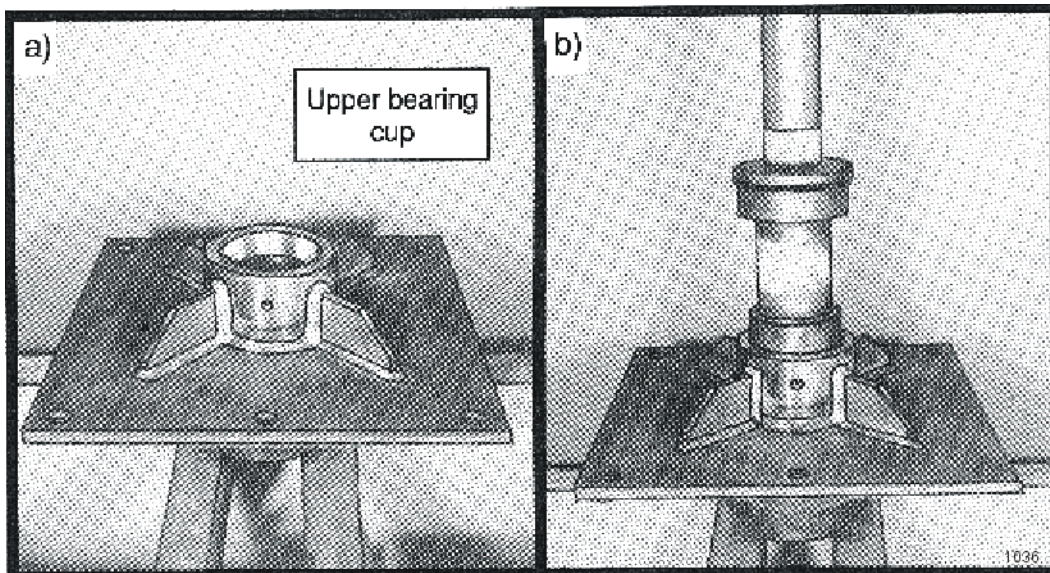

MAINTENANCE

BEARING ADJUSTMENT

1 – Clamp the bottom end of the spindle securely in a vise so the spindle housing turns freely.

2 – Position a magnetic base dial indicator on the outer diameter of the spindle housing. Locate the end of the dial indicator against the flat end of the spindle shaft. The dial indicator will now measure accurately bearing end play.

3 – Tighten the bearing adjustment nut until there is .012 inch movement when the spindle housing is pried upward away from the vise jaws.

4 – When there is .012 inch free play between the spindle and housing, install the bearing lock nut (thick nut). Hold the adjusting nut securely and tighten the lock nut to 300 ft. lbs. of torque.

5 – After the lock nut is tightened, there must be .001 inch to .003 inch of free play when lightly prying up on the spindle housing.

If the end play is correct, .001 inch to .003 inch, bend tabs up on jam washer to prevent the lock nut from loosening.

If the end play is NOT correct, loosen the lock nut and turn the adjustment nut as required and re-tighten the lock nut. Repeat first part of step 5.

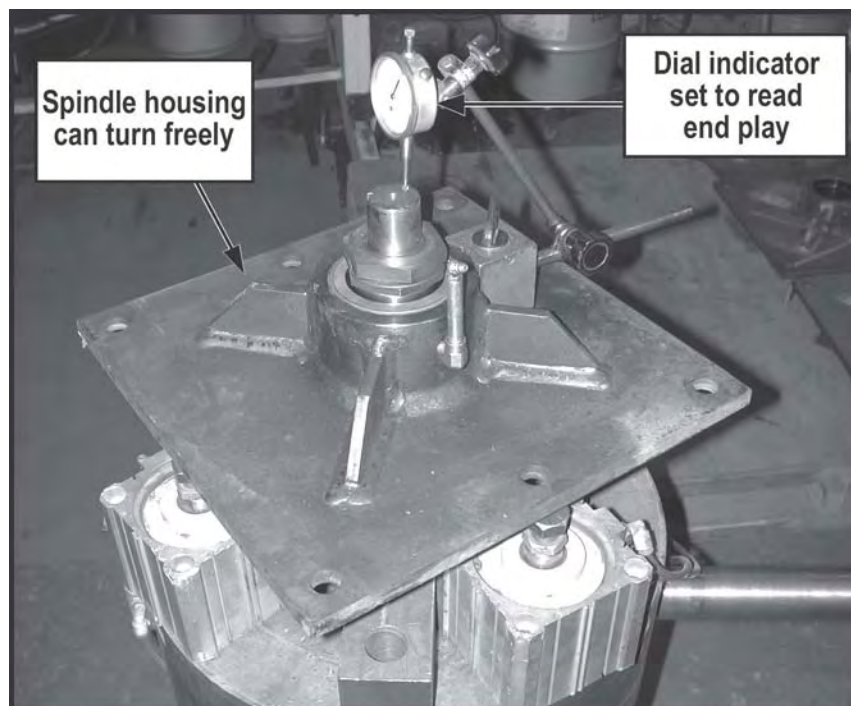

MAINTENANCE

DAILY MAINTENANCE SCHEDULE

The following services should be performed **daily** or every **8 hours** of service, following the detailed maintenance instructions in the operators manual.

- _____ Pump Drive Shaft: If required with drive shaft / coupler check for end play and lubricate at zerks.
- _____ Crankshaft adapter: If equipped with rubber grommets check condition, replace if missing or damaged.
- _____ Non-Greaseless Pivot points: Inject grease until it appears at ends. (Check Maintenance Section)
- _____ Hydraulic fittings: Check for leaks with paper or cardboard. Tighten fittings or replace hoses immediately.
- _____ Knives: Inspect for missing or damaged knives, change (only complete sets) as needed.
- _____ Belts: Check / Tighten / Replace belts as needed.
- _____ Main Frame / Deck: Unless otherwise specified retorque bolts according to torque specifications in this section.
- _____ Hydraulic Fluid Level: Add, if required, per fluid recommendations.
- _____ Rear Flail Drive, Bearing
Flange and Shaft Couplers: Grease as instructed in the detailed (if applicable) maintenance section.
- _____ Cutter Shaft and Ground Roller: Grease as instructed in the detailed maintenance section

Service performed by: _____ Date: ___/___/___ Hour
Meter: _____

Maintenance Section

** This page may be copied and used as part of the daily maintenance routine.

MAINTENANCE

JD 7X30 COUGAR

PARTS SECTION

PARTS ORDERING GUIDE

The following instructions are offered to help eliminate needless delay and error in processing purchase orders for the equipment in this manual.

1. The Parts Section is prepared in logical sequence and grouping of parts that belong to the basic machine featured in this manual. Part Numbers and Descriptions are given to help locate the parts and quantities required.

2. The Purchase Order must indicate the **Name and Address** of the person or organization ordering the parts, **who should be charged**, and if possible, the **serial number of the machine** for which the parts are being ordered.

3. The purchase order must clearly list the **quantity of each part**, the complete and correct **part number**, and the basic **name of the part**.

4. The manufacturer reserves the right to substitute parts where applicable.

5. Some parts may be unlisted items which are special production items not normally stocked and are subject to special handling. Request a quotation for such parts before sending a purchase order.

6. The manufacturer reserves the right to change prices without prior notice.

NOTE: When ordering replacement decals, refer to the part numbers and descriptions listed in the safety section in the front of this manual.



1000

For maximum safety and to guarantee optimum product reliability, always use genuine **Tiger** replacement parts. The use of inferior replacement parts may cause premature or catastrophic failure which could result in serious injury or death.

Direct any questions regarding parts to:

Tiger Corporation
3301 N. Louise Ave.
Sioux Falls, SD 57107
1-800-843-6849
1-605-336-7900

PARTS SECTION TABLE OF CONTENTS

SECTION	PAGE
TRACTOR MOUNT KIT – MAIN FRAME	5-4
TRCTR MNT KIT – HYD BRAKE VALVE	5-6
TRCTR MNT KIT - SWIVEL	5-8
JOYSTICK AND SWITCH BOX	5-10
LV-5 SP DANFOSS	5-12
LV-5 SP HUSCO	5-14
POLYCARBONATE SAFETY WINDOW	5-16
DRIVESHAFT	5-17
WHEEL WEIGHT	5-18
WHEEL SPACER	5-19
FRONT PUMP AND GRILL GUARD - OPTIONAL	5-20
SAFETY LIGHT KIT	5-21

TRACTOR MOUNT KIT - MAIN FRAME

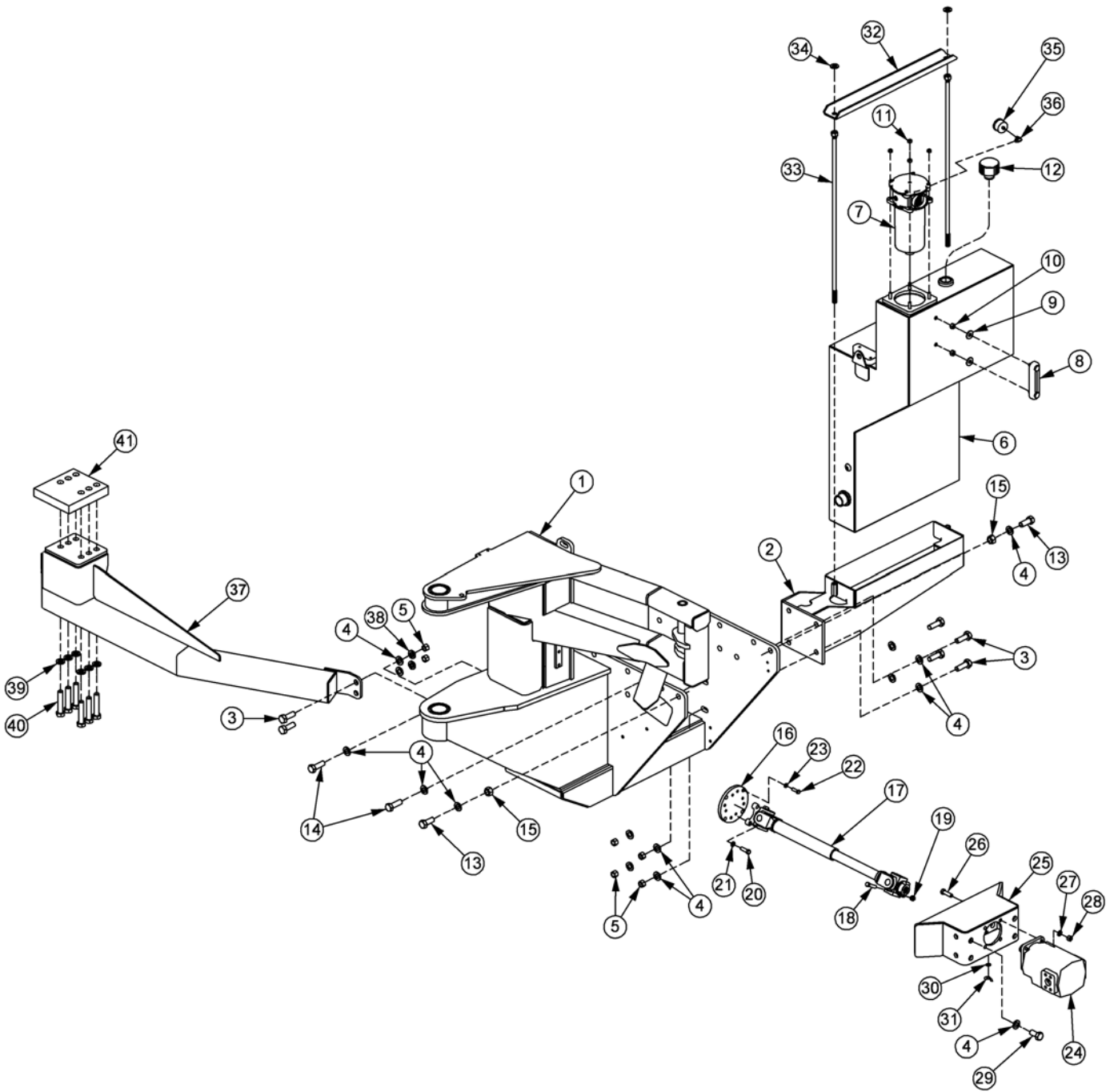

TRACTOR MOUNT KIT - MAIN FRAME

ITEM	PART NO.	QTY.	DESCRIPTION
1	06300105	1	MNFRM,JD7130,SBR,OS BOOMRST
2	06300060	1	MNT,HYDRO TANK,JD6000
3	21833	6	CAPSCREW,3/4 X 2-1/4 NC
4	33880	37	FLATWASHER,3/4,GR 8,SAE
5	21825	6	HEX NUT,3/4 NC
	06700090	1	TANK,RES,JD6000,ASSY
6	06380012	1	TANK,RES,JD60004WD(34GAL)
7	06505044	1	FLTR ASSY,IN-TANK CPLT,SAE10M
*	35259	1	FILTER ELEMENT
8	06505067	1	SIGHT GAUGE,JD6000,TANK,34GAL
9	22018	2	FLATWASHER,1/2,WIDE
10	21725	2	HEX NUT,1/2 NC
11	21627	4	NYLOCK NUT,3/8 NC
12	06505077	1	CAP,BREATHER,O-RING
13	31731	21	CAPSCREW,20MMX50MM(2.5 PITCH)
14	27281	2	CAPSCREW,20MMX60MM(2.5P)GR10.
15	31722	19	HEX NUT,20MM(2.5P)GR 10.9,FLN
16	34998	1	SPACER,DRIVESHAFT,JD72-7510/20
17	34999	1	DRIVESHAFT,U-JOINT,JD62-7510/2
18	21658	1	CAPSCREW,7/16 X 2 NF,GR8
19	34848	1	HEX NUT,7/16 NF,GR8 (STOVER)
20	21680	4	CAPSCREW,7/16 X 1-1/4NC GR5
21	21989	4	LOCKWASHER,7/16
22	23113	4	CAPSCREW,10MMX30MM(1.5 PITCH)
23	32691	4	LOCKWASHER,10MM
24	23152	1	PUMP,P350-1 3/4 GEAR
25	34993	1	PUMP MNT,JD,U DRIVE
26	21732	4	CAPSCREW,1/2 X 1-3/4 NC
27	21990	4	LOCKWASHER,1/2
28	21725	4	HEX NUT,1/2 NC
29	24860	4	CAPSCREW,20mmx40mm(2.5P)10.9
30	22014	1	FLATWASHER,1/4
31	32519	1	NUT,WING,1/4-20 UNC
32	06410352	1	CHANNEL,MNT,TANK,TIE-BOLT
33	06380014	2	TIE BOLT,SIDE TANK,HYDRO
34	33764	2	FLATWASHER,5/8,GR 8,SAE
35	6T0649	1	FILTER GAGE
36	TF4888	1	STREET ELBOW,1/8 X 90
37	06300123	1	AXLE BRACE,RH
38	21993	2	LOCKWASHER,3/4,GR 8
39	24881	6	LOCKWASHER,20MM
			JD73-7530 TRACTORS
40	27281	6	CAPSCREW,20MM x 60MM,2.5P
			JD71-7230 TRACTORS
40	32703	6	CAPSCREW,20MM x 100MM,2.5P
41	06400173	2	SPACER,AXLE

TRCTR MNT KIT - HYDRAULICS, BRAKE VALVE

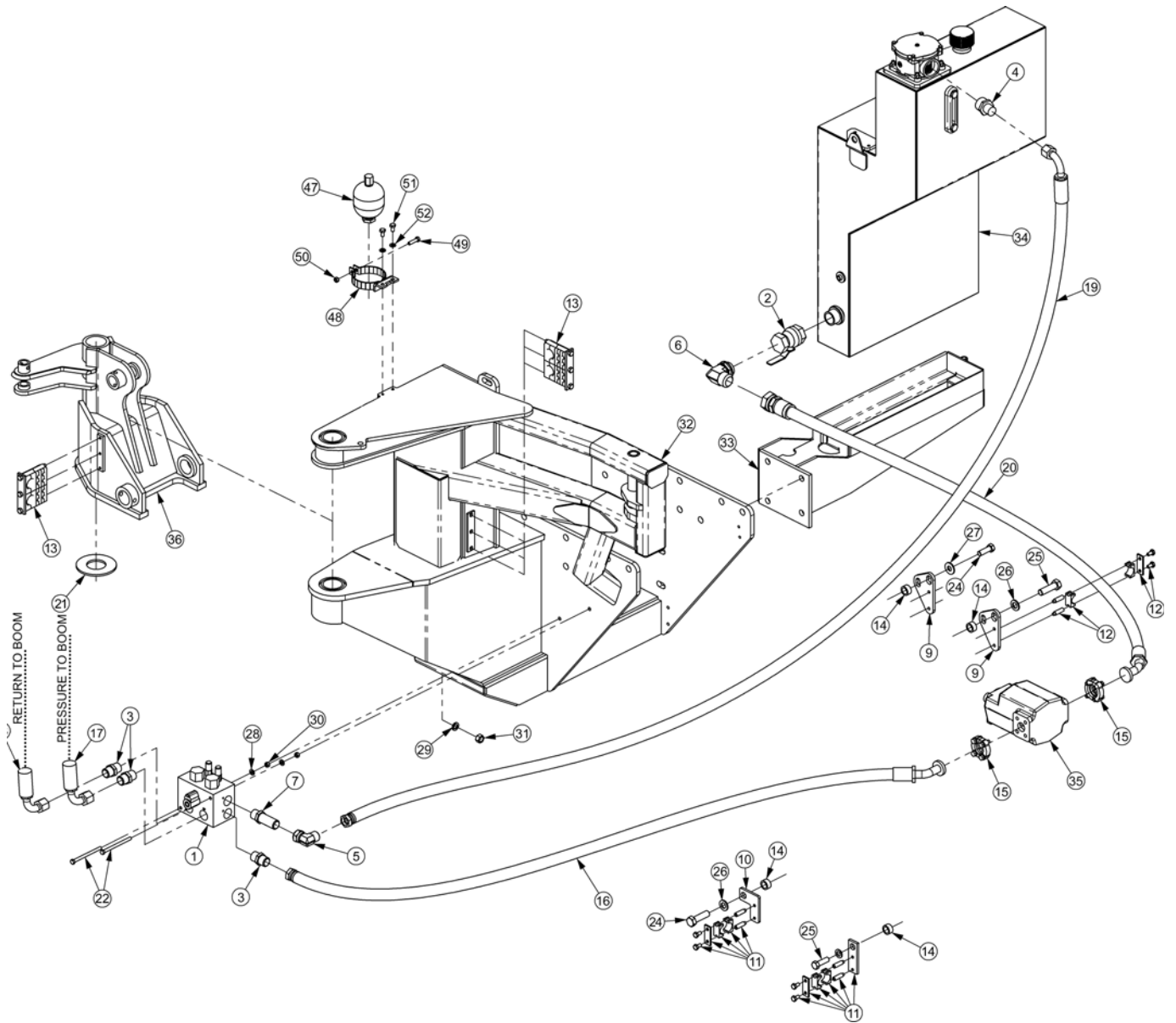

TRCTR MNT KIT - HYDRAULICS, BRAKE VALVE

ITEM	PART NO.	QTY.	DESCRIPTION
1	06510083	1	VALVE,BRAKE,SOL,3000PSI,METRI
2	34309	1	BALL VALVE,1 1/2 FOR
3	33555	3	ADAPTER,1MORBx1MJIC
4	34064	1	ADAPTER,1 1/4MOR X 1MJ
5	33259	1	ELBOW,1MJ X 1FJX 90
6	34655	1	ELBOW,1-1/2ORBx1-1/2MJ
7	32869	1	NIPPLE,MALE LONG,1MOR X 1MJ
8	32382	1	BRACKET,HOSE
9	06400786	2	BRKT,CLAMP,TUBE,SUCTION
10	34626	1	BRKT,TUBE,CLAMP
11	34076	2	CLAMP KIT,PRESSURE HOSE,1
12	06505017	2	CLAMP KIT,1"HOSE,SINGLE
13	06505085	2	HOSE CLAMP KIT
14	24849	4	SPACER,7/8 ID X 1-1/4 OD X 5/8
15	TF4852	2	KIT,FLANGE,#20
16	06506002	1	HOSE/TUBE,#16x66(16FJXx20FLH)
17	34412	1	HOSE,#16x85(16FJXx16FJX90)
18	34082	1	HOSE,#16x89(16FLXx16FJX90)
19	06500249	1	HOSE,#16x111(16FJX90x16FJX)
20	06506036	1	HOSE/TUBE,#24x79(24FJXx20FLH)
21	06520250	1	BEARING
22	6T2131	2	CAPSCREW,3/8 X 5-1/2 NC
23	21782	1	CAPSCREW,5/8 X 1-3/4 NC
24	22423	1	CAPSCREW,16MMX50MM(2.0 PITCH)
25	30708	2	CAPSCREW,20mmx90mm2.5P,GR10.9
26	33880	2	FLATWASHER,3/4,GR 8,SAE
27	34833	1	FLATWASHER,16MM
28	21988	4	LOCKWASHER,3/8
29	21992	1	LOCKWASHER,5/8
30	21625	2	HEX NUT,3/8 NC
31	21775	1	HEX NUT,5/8 NC
32	06300105	1	MAIN FRAME
33	06300060	1	TANK FRAME - REFER TO MAIN FRAME PAGE
34	06700163	1	HYDRAULIC TANK - REFER TO MAIN FRAME PAGE
35	23152	1	PUMP - REFER TO MAIN FRAME PAGE
36	06700150	1	SWIVEL - REFER TO BOOM MNTG KIT PAGE
47	24300	1	ACCUMULATER
48	23888	1	BRKT,ACCUMULATOR
49	21632	1	CAPSCREW,3/8 X 1-1/2 NC
50	21627	1	NYLOCK NUT,3/8 NC
51	21629	2	CAPSCREW,3/8 X 3/4 NC
52	21988	2	LOCKWASHER,3/8

TRACTOR MOUNT KIT - BOOM SWIVEL

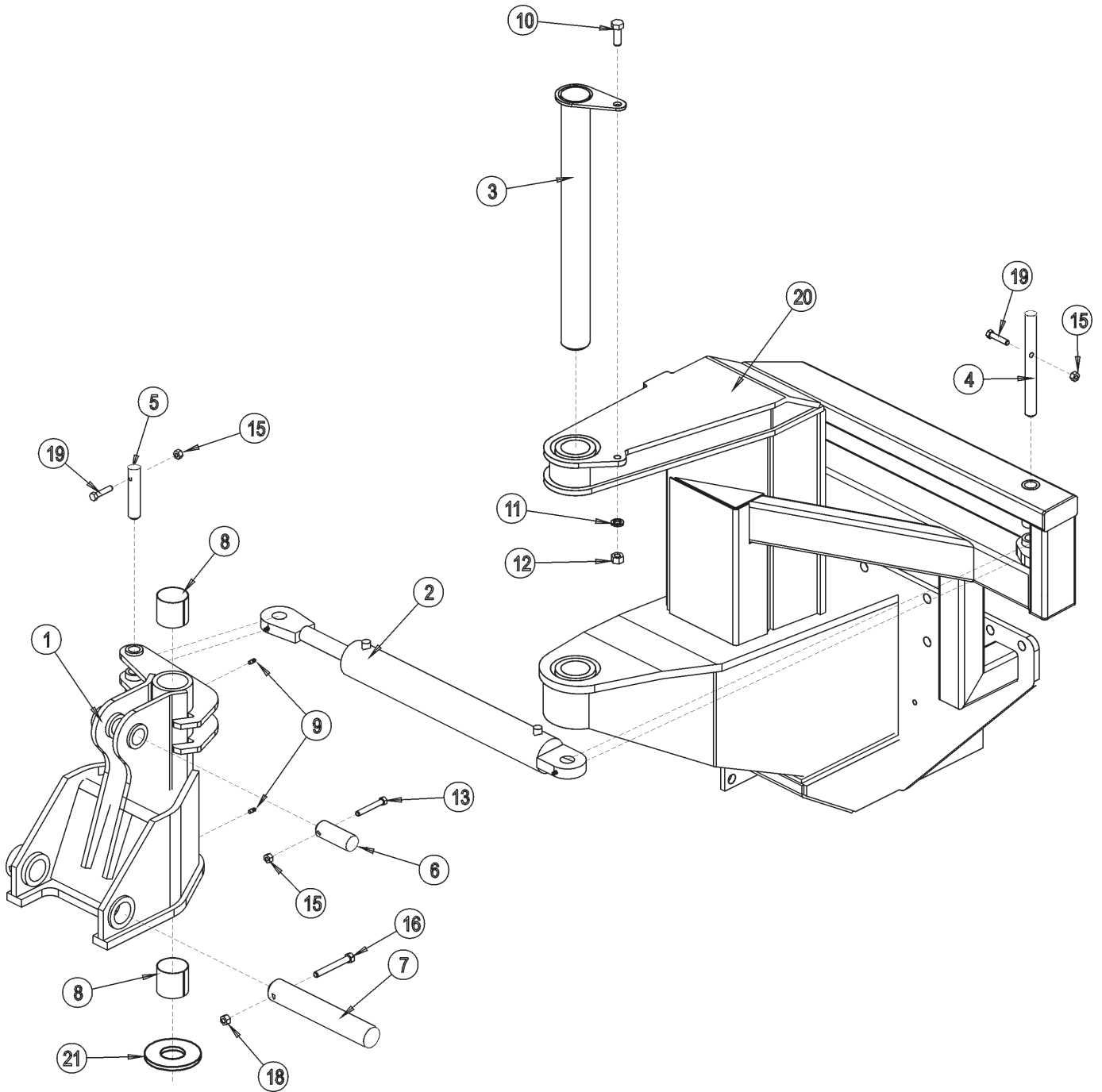

TRACTOR MOUNT KIT - BOOM SWIVEL

ITEM	PART NO.	QTY.	DESCRIPTION
1	06700150	1	SWIVEL,W/O BUSHING
2	33705	1	CYLINDER,3X17 1/2,WELDED
3	32381	1	PIN,2 1/2,SWIVEL,SABER
4	33710	1	PIN,CYLINDER,1,SWIVEL,SABER
5	32380	1	PIN,CYL,1,SWIVEL,SABER
6	32372	1	PIN,CYLINDER,STAGE,2ND
7	32378	1	PIN,BOOM TO SWIVEL,SABER
8	32322	2	BEARING,DX,2 1/2X2 1/2LONG,
9	6T3211	2	GREASE ZERK,1/8
10	21782	1	CAPSCREW,5/8 X 1-3/4 NC
11	21992	1	LOCKWASHER,5/8
12	21775	1	HEX NUT,5/8 NC
13	21687	1	CAPSCREW,7/16 X 3 NC
15	21677	3	NYLOCK NUT,7/16 NC
16	21741	1	CAPSCREW,1/2 X 4 NC
18	21727	1	NYLOCK NUT,1/2 NC
19	21683	2	CAPSCREW,7/16 X 2 NC
20	*	REF.	MAIN FRAME - REFER TO MAIN FRAME PARTS
21	06520049	1	BEARING, WASHER

JOYSTICK AND SWITCH BOX

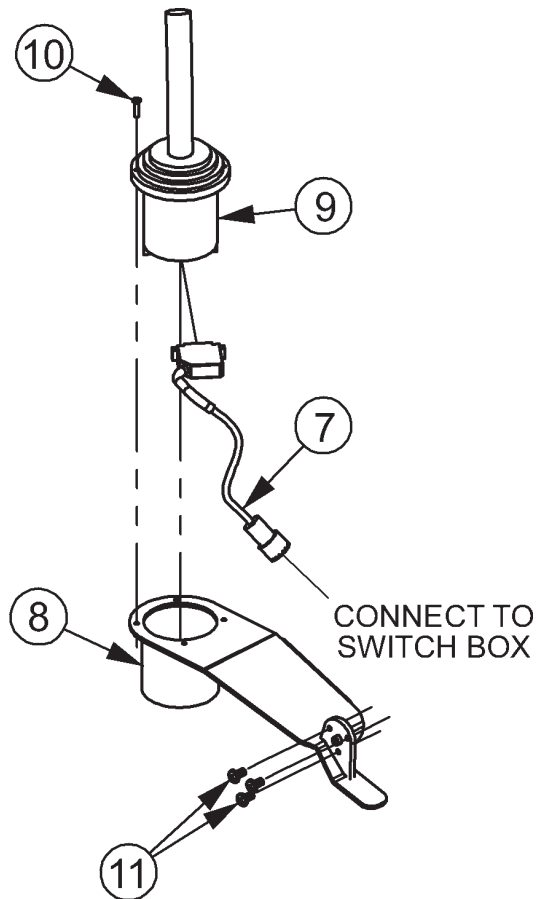
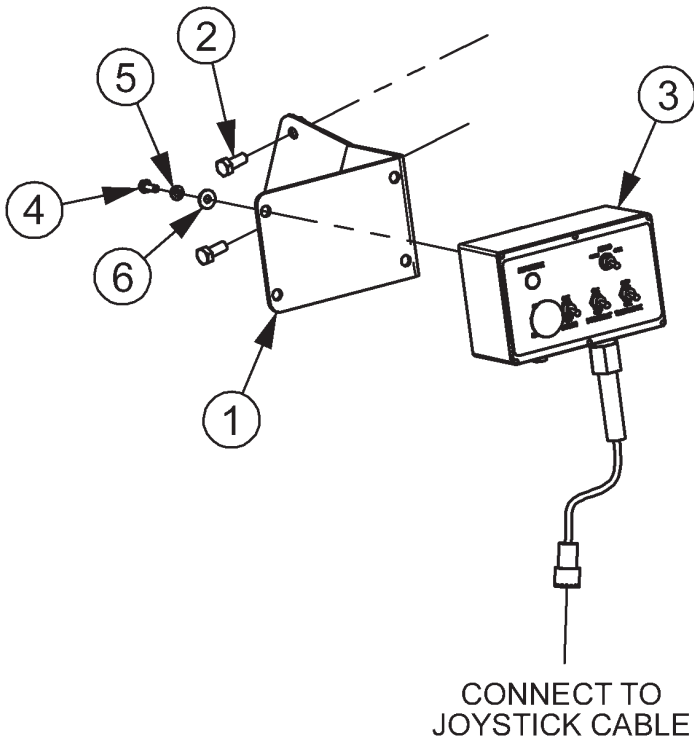

ITEM	PART NO.	QTY	DESCRIPTION
1	33355	1	MNT,BRKT,SWITCH BOX
2	27513	2	CAPSCREW,10MMX25MM(1.5 PITCH)
3	06510196	1	SWITCHBOX,BOOM,DF,GND
4	21529	4	CAPSCREW,1/4 X 3/4 NC
5	21986	4	LOCKWASHER,1/4
6	22014	4	FLATWASHER,1/4
7	33693	1	CBL,EXT,4FT,JOYST,W/SUB-D CONN
8	06370085	1	MNT,JOYSTICK,JD7130
9	33691	1	JOYST,4AXIS,RH,DF,W/SUB-D CONN
10	32829	4	SCREW,MACHINE,10-32X3/4,FLATH
11	32403	3	SCRW,MACH,1/4-20X1/2,PHY,PAN,Z

IVT JOYSTICK AND SWITCH BOX

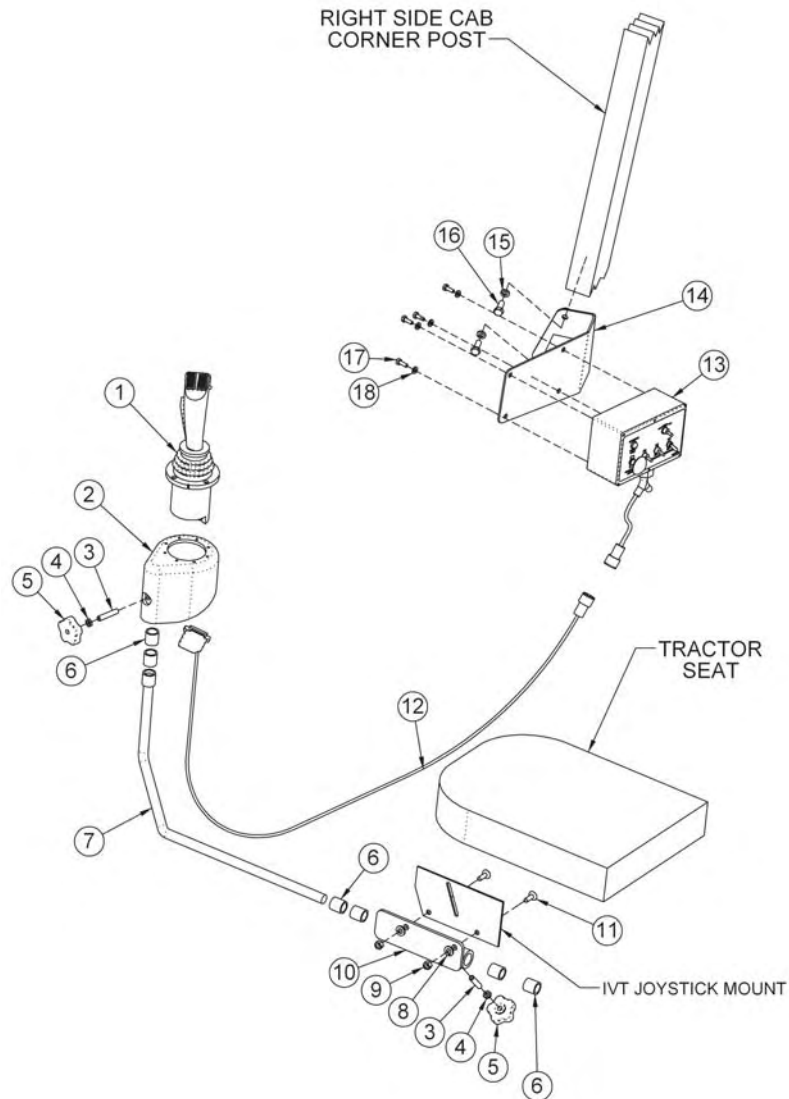

ITEM	PART NO.	QTY.	DESCRIPTION
1	33691	1	JOYSTICK
2	35033	1	CAN,JOYSTICK
3	35205	2	SETSCREW,3/8x2,NC,KNURLED
4	35206	2	HEX NUT,JAMB,3/8,NC
5	35204	2	KNOB
6	35256	7	BUSHING,NYLON
7	06420095	1	ROD,FORMED
8	21988	2	LOCKWASHER,3/8
9	21625	2	HEX NUT,3/8,NC
10	06370093	1	MNT,JOYSTICK,JD-IVT
11	28734	2	CAPSCREW,FLT/SKT HD,3/8 x 1,NC
12	33693	1	CBL,EXT,4FT,JOYST,W/SUB-D CONN
13	06510196	1	SWITCHBOX
14	06370095	1	MNT,SWITCHBOX
15	32691	2	LOCKWASHER,10mm
16	25188	2	CAPSCREW,10mm x 15mm(1.5P)
17	21529	4	CAPSCREW,1/4 x 3/4,NC
18	21986	4	LOCKWASHER,1/4

LIFT VALVE - 5 SP DANFOSS

HOSE ROUTING

- A - TO ACCUMULATOR
- B - TO SECONDARY CYLINDER GLAND
- C - TO DECK ROLL CYLINDER GLAND
- D - TO BOOM SWIVEL CYLINDER GLAND
- E - TO SHIELD CYLINDER GLAND
- F - TO MAIN BOOM CYLINDER BUTT
- G - TO SECONDARY CYLINDER BUTT
- H - TO DECK ROLL CYLINDER BUTT
- J - TO BOOM SWIVEL CYLINDER BUTT
- K - TO SHIELD CYLINDER BUTT
- L - TO MAIN BOOM CYLINDER GLAND
- R - RETURN, VALVE TO REMOTES
- P - PRESSURE, VALVE TO REMOTES
- LS - LOAD SENSE, VALVE TO REMOTES

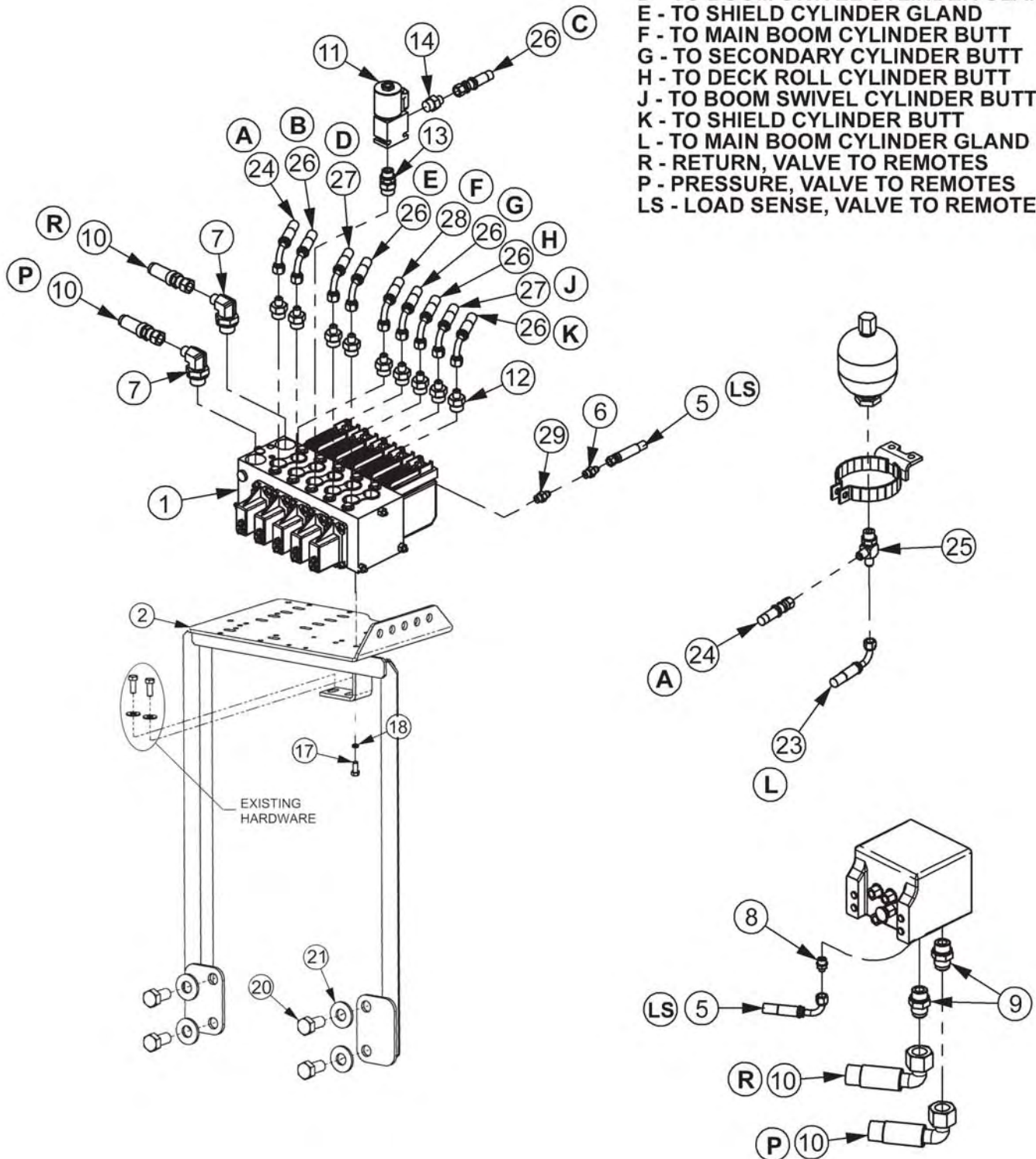

LIFT VALVE - 5 SP DANFOSS

ITEM	PART NO.	QTY	DESCRIPTION
1	06502096	1	VALVE, 5SP, DF, PVEA
2	06340032	1	VALVE MOUNT
5	06500400	1	HOSE,#4x34
6	33392	1	ADAPTER,5/16MORB X 3/8MJ (STANDARD TRACTORS)
	06503142	1	ADAPTER,CHECK VALVE (PREMIUM TRACTORS)
7	33294	2	ELBOW,3/4MOR X 1/2MJIC 90
8	06503069	1	ADAPTER,14mmORBx3/8MJ
9	06503012	2	ADPTR,27MMORBx3/4MJ
10	34612	2	HOSE,#8
11	06510050	1	TRV LCK,METRIPACK COIL
12	32807	9	ADAPTER,5/8MORB X 3/8MJ
13	31611	1	ADAPTER,5/8 OR X 1/2 ADJ OR
14	33271	1	ADAPTER,1/2 MOR X 3/8 MJ
17	21579	4	CAPSCREW,5/16 X 3/4 NC
18	21987	4	LOCKWASHER,5/16
20	24860	4	CAPSCREW,20MM x 40MM
21	28624	4	FLATWASHER,20MM
23	34631	1	HOSE,#6x126
24	06500150	1	HOSE,#6x142
25	06503029	1	TEE,RUN,1/2ORBx3/8MJx3/8MJ
26	34358	8	HOSE,#6x196
27	06500345	2	HOSE,#6x171
28	06500149	1	HOSE,#6x220
29	06503143	1	ADAPTER,5/16MOR X 3/8FOR (PREMIUM TRACTORS)

5 SP CABLE CONTROLS & SELECTOR VALVE

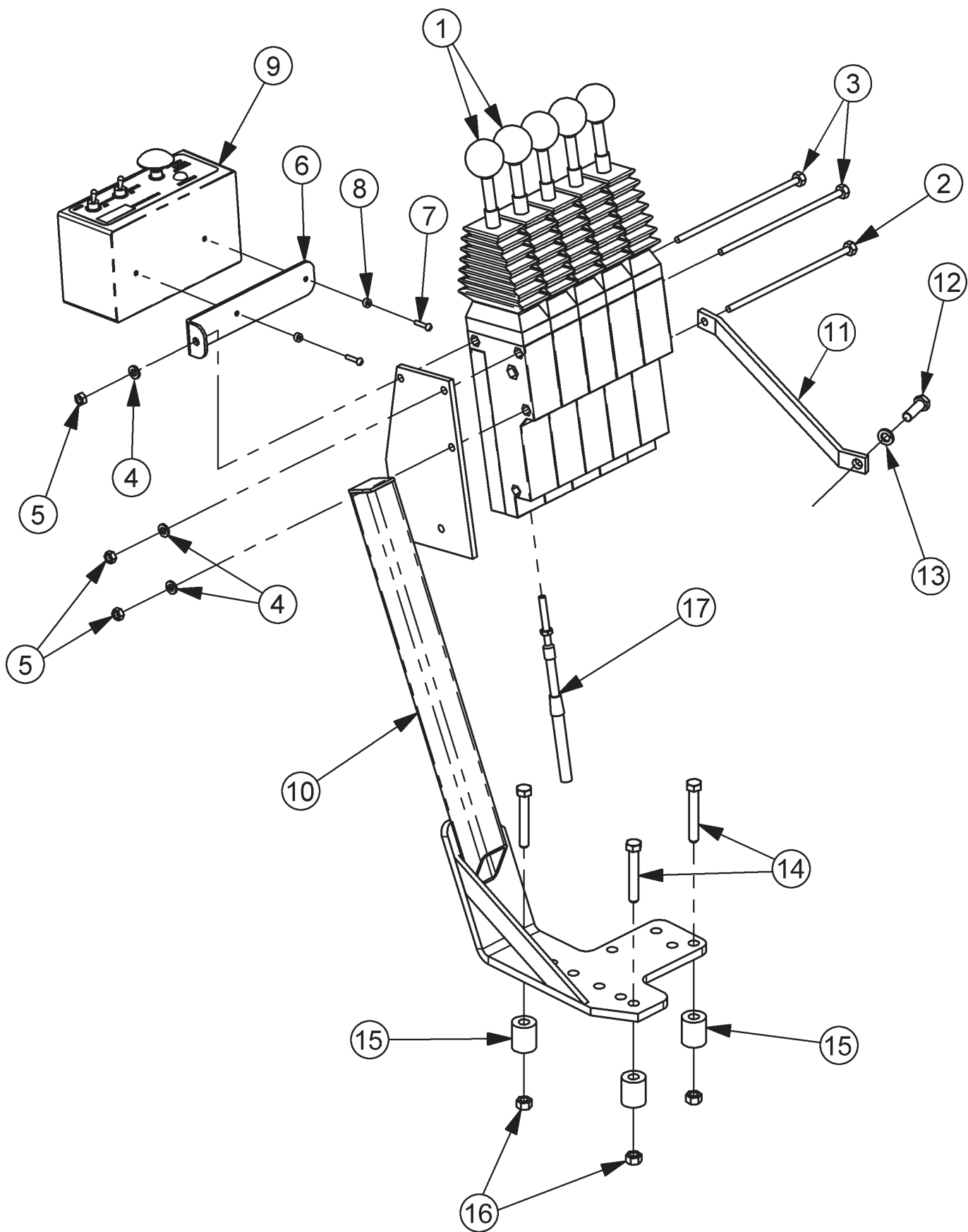

5 SP CABLE CONTROLS & SELECTOR VALVE

ITEM	PART NO.	QTY.	DESCRIPTION
1	6T1251	5	CBL CTRL BOX,180 DEG
2	34332	1	CAPSCREW, 1/4" X 9-1/4"
3	21548	2	CAPSCREW, 1/4" X 9" NC
4	21986	3	LOCKWASHER,1/4
5	21525	3	HEX NUT,1/4 NC0
6	34496	1	BRKT,SWITCHBOX,UNI
7	6T3951	2	SCREW,MACHINE 8/32 X 1/2
8	32360	2	LOCKWASHER,#8
9	06510100	1	SWITCHBOX,BOOM,GND
10	23865	1	CBL CTRL MT BRKT, 9030-
11	30750A	1	BRKT,CBL,CTRL,JD6000
12	33534	1	CAPSCREW,10MMx20MM
13	32691	1	LOCKWASHER,10MM
14	21636	3	CAPSCREW,3/8 X 2-1/2 NC
15	27082B	3	SPACER
16	21627	3	NYLOCK NUT,3/8 NC
17	34623	5	CBL,CNTRL,122

LIFT VALVE - 5 SP HUSCO

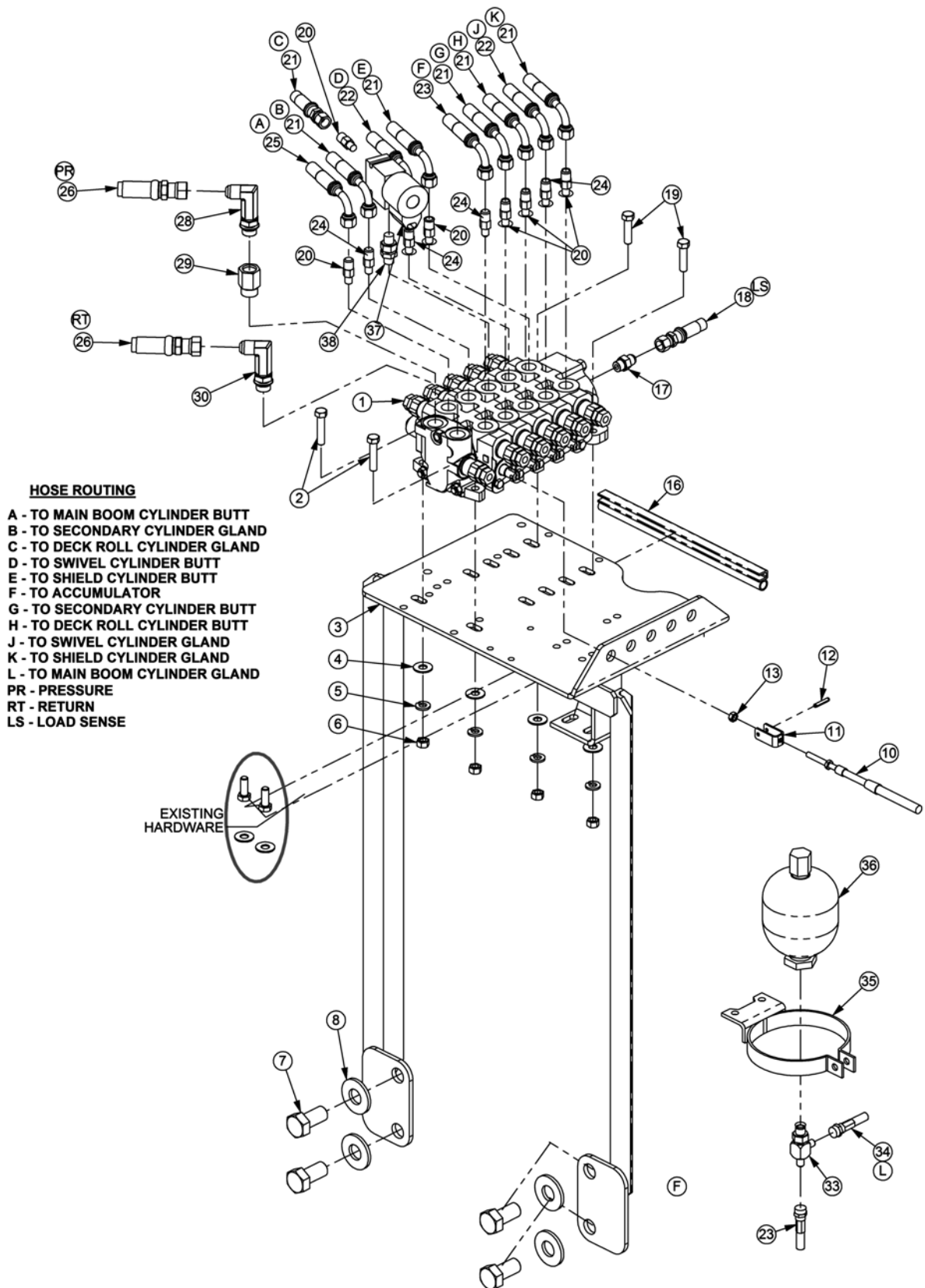

LIFT VALVE - 5 SP HUSCO

ITEM	PART NO.	QTY.	DESCRIPTION
1	06502103	1	VLV,5SP,HSC ROTARY MOWER
	06502115	1	VLV,5SP,HSC FLAIL MOWER
2	21633	2	CAPSCREW,3/8 X 1-3/4 NC
3	06340032	1	VALVE MNT
4	22016	4	FLATWASHER,3/8
5	21988	4	LOCKWASHER,3/8
6	21625	4	HEX NUT,3/8 NC
7	34860	4	CAPSCREW,20MMx40MM
8	38624	4	FLATWASHER
9	06410429	1	MOUNT,VALVE,RIGHT
10	34623	5	CBL,CNTRL,122
11	6T4411	5	CLEVIS,CBL CTRL,3/16
12	6T3017	5	ROLLPIN,3/16 X 1
13	21500	5	HEX NUT,1/4 NF
16	28053	1	TRM LK,9/16X1/8FN PBL*100-1/8
17	32901	1	ADAPTER,3/8 MOR X 3/8 MJ (STANDARD TRACTORS)
	06503142	1	ADAPTER,CHECK VALVE (PREMIUM TRACTORS)
18	06500400	1	HOSE, 1/4 x 34
19	21632	2	CAPSCREW,3/8 X 1-1/2 NC
20	33271	9	ADAPTER,1/2 MOR X 3/8 MJ
21	34358	8	HOSE,1/4 x 196
22	06500345	1	HOSE,1/4 x 171
23	34631	1	HOSE,1/4 x 126
24	06502036	4	RSTRCTR.06,OUT,1/2MBx3/8MJ
25	06500149	1	HOSE,1/4 x 220
26	34612	2	HOSE, 1/2 x 34
28	33293	1	ELBOW,LONG
29	32678	1	ADAPTER,5/8ORB x 1/2FOR
30	33383	1	ELBOW,LONG
33	06503029	1	TEE,BRANCH
34	06500150	1	HOSE,1/4 x 142
35	23888	1	BRKT,ACCUMULATER
36	24300	1	ACCUMULATER
37	06510050	1	TRAVEL LOCK
38	31329	1	ADAPTER,1/2 MOR X 1/2 ORB ADJ
39	06505035	1	VALVE COVER - NON CAB ONLY (NOT SHOWN)
40	32900	2	QUICK COUPLERS (TO TRACTOR REMOTES, NOT SHOWN)

TRACTOR REMOTES

PREMIUM SERIES TRACTOR

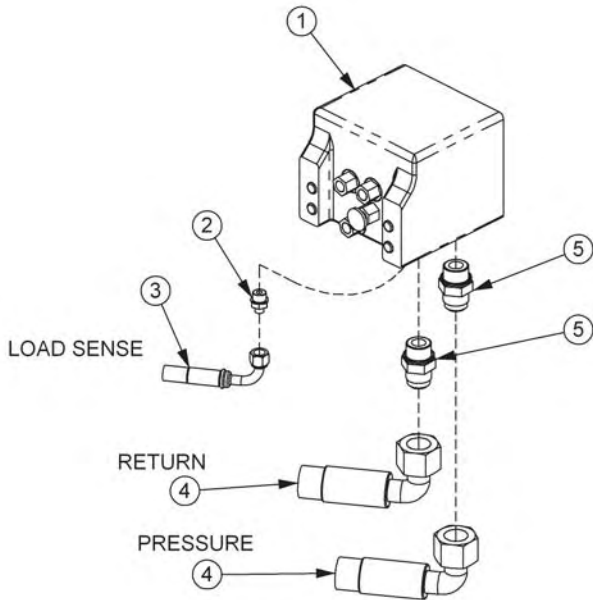

STANDARD SERIES TRACTOR

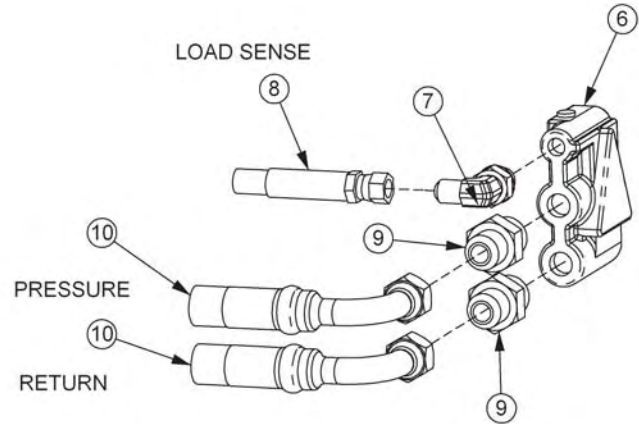

ITEM	PART NO.	QTY.	DESCRIPTION
1			TRACTOR REMOTES (PREMIUM)
2	06503069	1	ADAPTER,14mmORB x 3/8MJ
3	06500267	1	HOSE,1/4 x 30(6FJX x 6FJX90)
4	06500269	2	HOSE,1/2 x 40(8FJX x 12FJX90)
5	06503012	2	ADPTR,27mmORB x 3/4MJ
6			TRACTOR REMOTES (STANDARD)
7	06503013	1	ELBOW,14mmORB x 5/16MJ
8	06500400	1	HOSE,1/4 x 30(5FJX x 6FJX)
9	33463	2	ADAPTER,22mmORB x 1/2MJ
10	34612	2	HOSE,1/2 x 34(8FJX x 8FJX90)

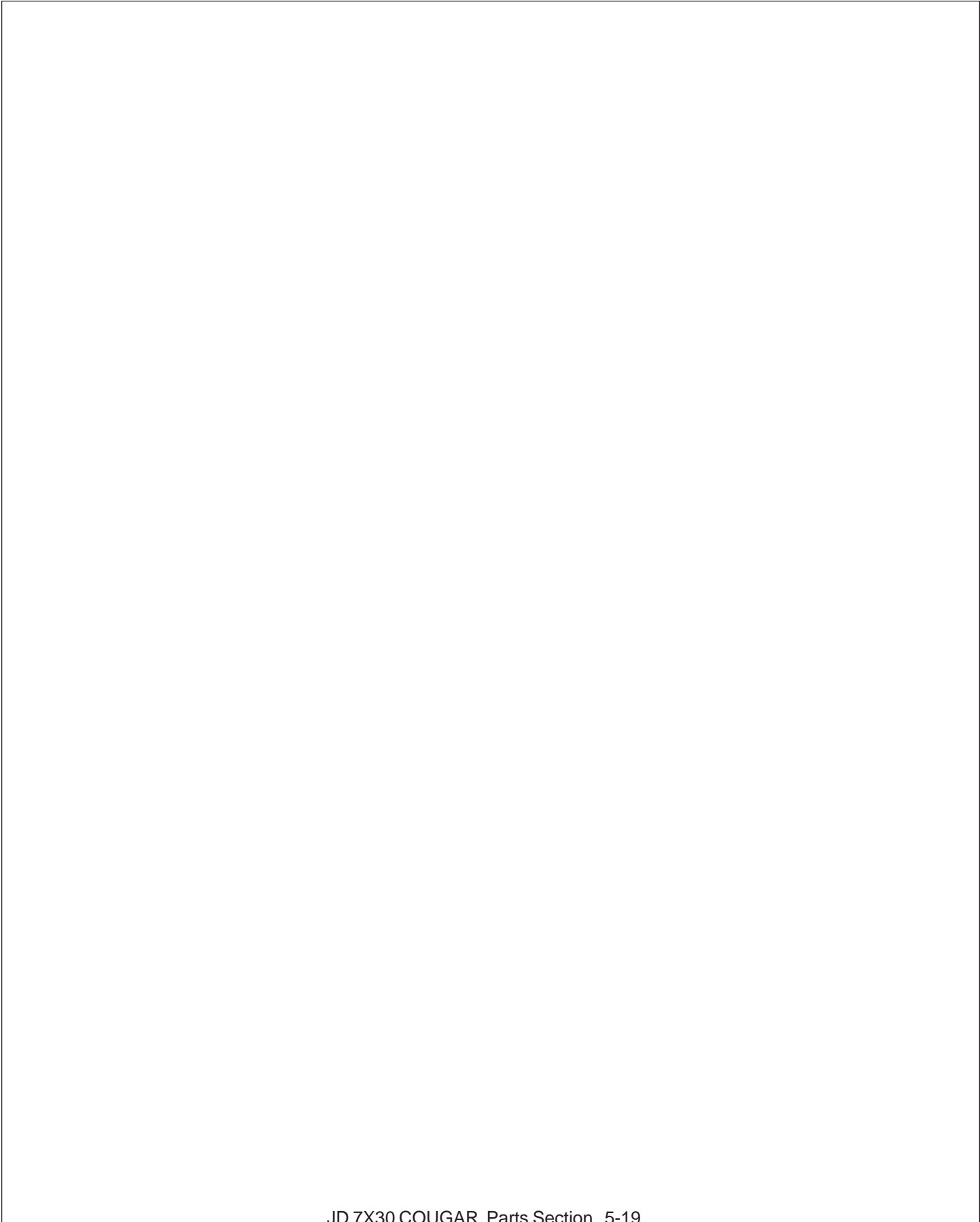

BOOM POLYCARBONATE CAB SAFETY WINDOW KIT

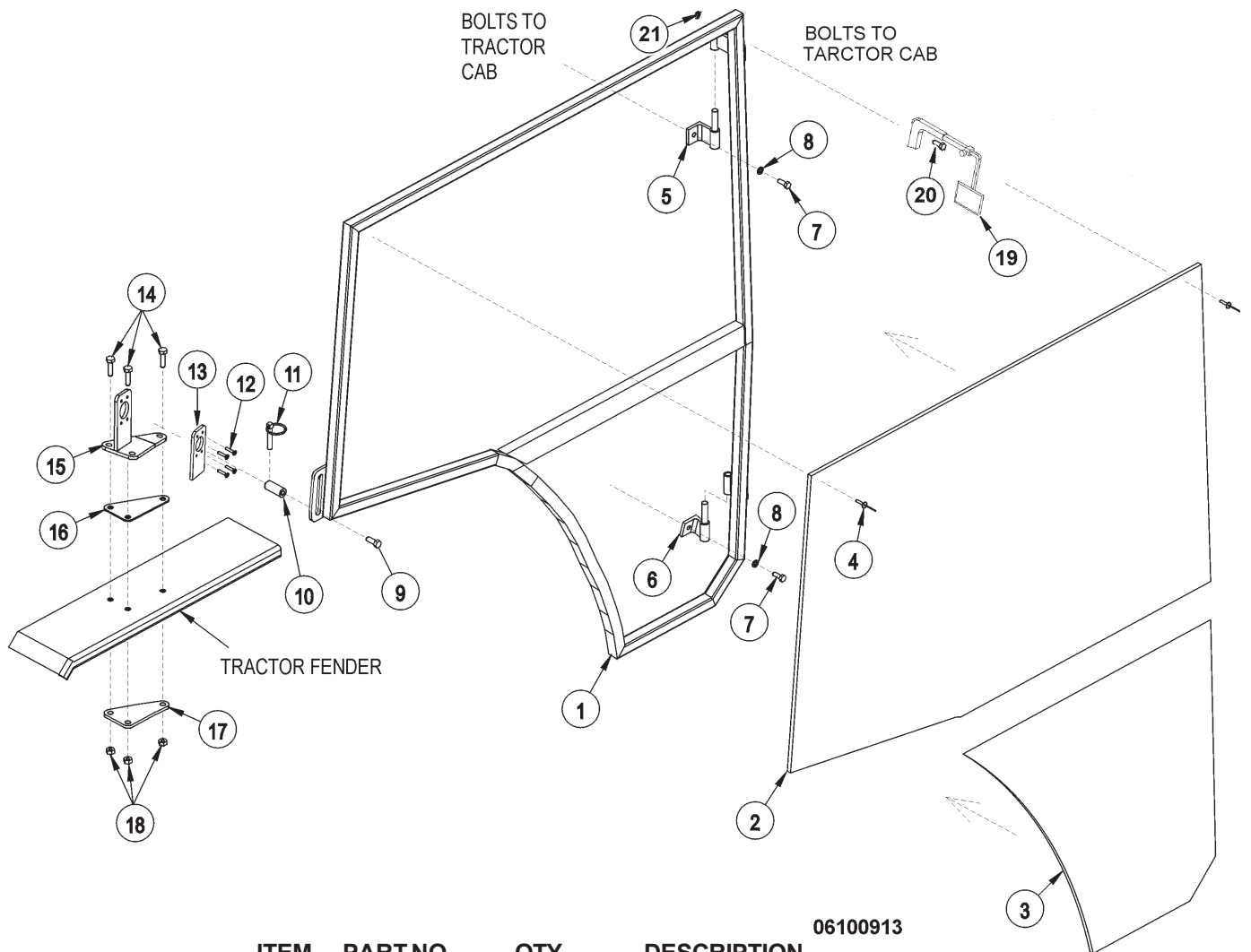

06100913

ITEM	PART NO.	QTY.	DESCRIPTION
	34625	AVAIL	FRAME AND WINDOW ASY
1	34619	1	WINDOW FRAME
2	28900A	1	LEXAN WINDOW
3	28901B	1	LEXAN WINDOW
4	6T3954	25	POP RIVET
5	28903A	1	HINGE - UPPER
6	28907A06	1	HINGE - LOWER
7	27508	2	CAPSCREW 8MM X 20MM
8	6T2619	2	LOCKWASHER 8MM
9	21630	1	CAPSCREW 3/8" X 1" NC
10	33583	1	PIN SAFETY SCREEN
11	RD1032	1	LYNCH PIN 1/4" X 2"
12	24889	4	MACHINE SCREW 10-32
13	06400005	1	GROMMET SAFETY SCREEN
14	21632	3	CAPSCREW 3/8" X 1 1/2"
15	06330000	1	SAFETY SCREEN LATCH
16	34270	1	PAD SAFETY SCREEN
17	34271	1	FENDER PLATE
18	21627	4	NYLOCK NUT 3/8"
19	AL77484	1	MIRROR BRKT, RH
20	21585	2	BOLTS 5/16"
21	21577	2	NYLOCK NUT 5/16"

PUMP DRIVESHAFT ASSEMBLY

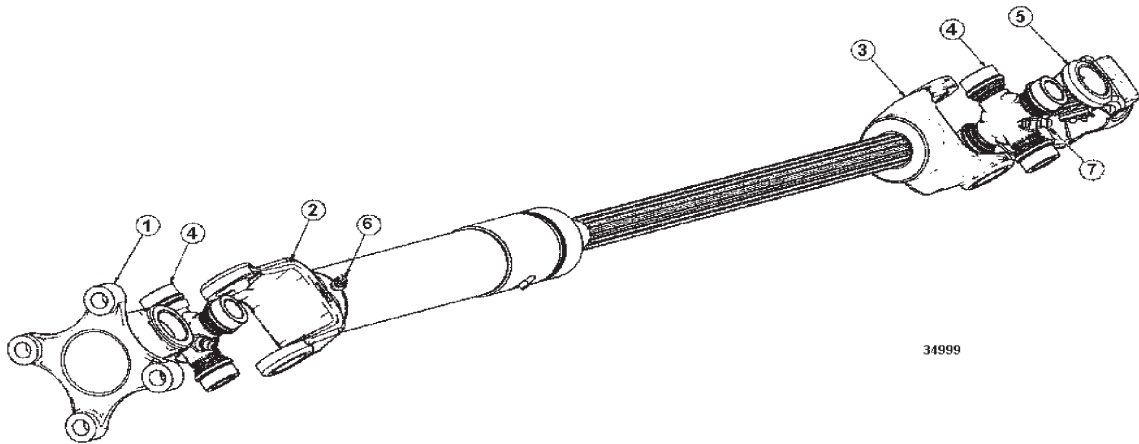

ITEM	PART NO.	QTY.	DESCRIPTION
*	34999	AVA	DRIVESHAFT,U-JOINT
1	06505004	1	YOKE PULLEY, 34999
2	06505005	1	SLEEVE, 34999
3	06505006	1	SHAFT, 34999
4	06505007	2	CROSS, 34999
5	06505008	1	YOKE DRIVE, 34999
6	6T3203	1	GREASE ZERK, 1/4 X 45
7	6T3207	3	GREASE ZERK, 1/4 X STR

WHEEL WEIGHT

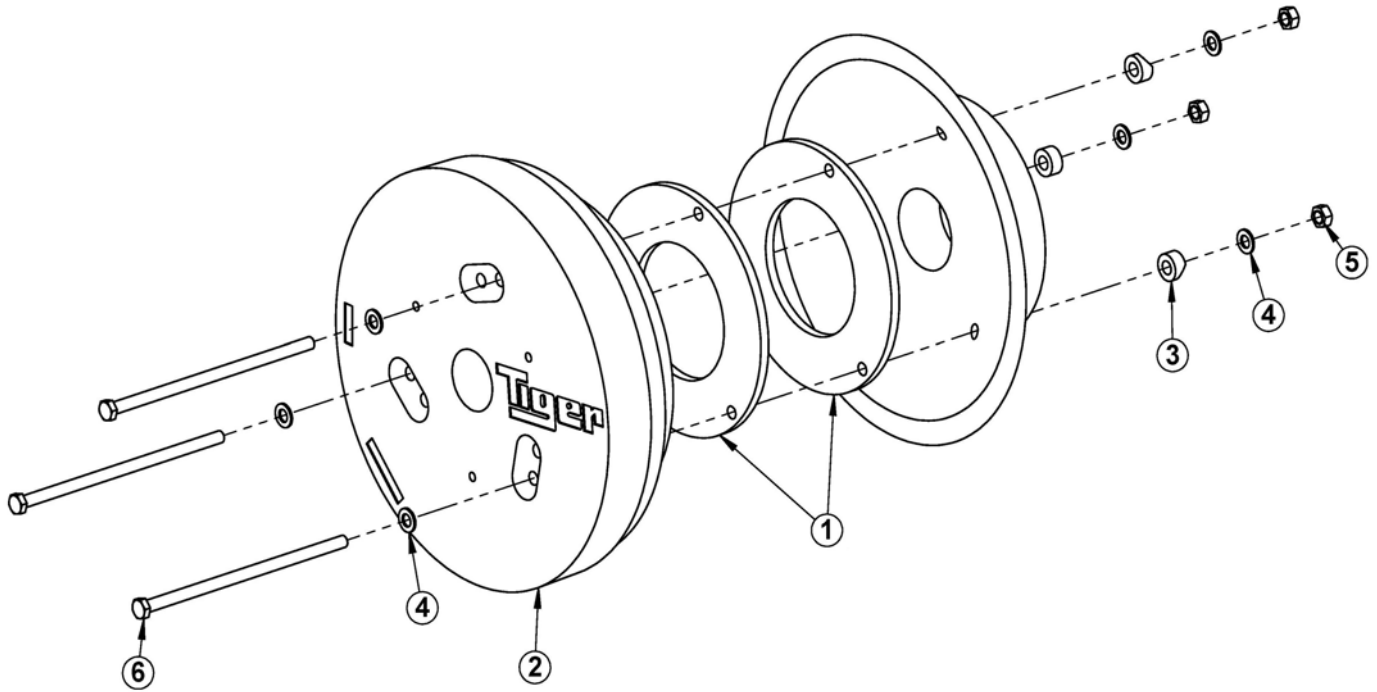

ITEM	PART NO.	QTY	DESCRIPTION
1	06400410	2	SPACER,JD,WHL WHT,RS
2	32615	1	WHL WT,INBOARD,1700#,DRLL&TAP 14.75OC,OUTBOARD
3	06430121	3	SPACER,JD,WHL WHT,RIM,CAST
4	06533000	6	FLATWASHER,7/8",GR8
5	06531000	3	HEX NUT, 7/8" NC,GR8
6	06530219	3	CAPSCREW,7/8x19-1/2,NC,GR8,4"THRD

WHEEL SPACER

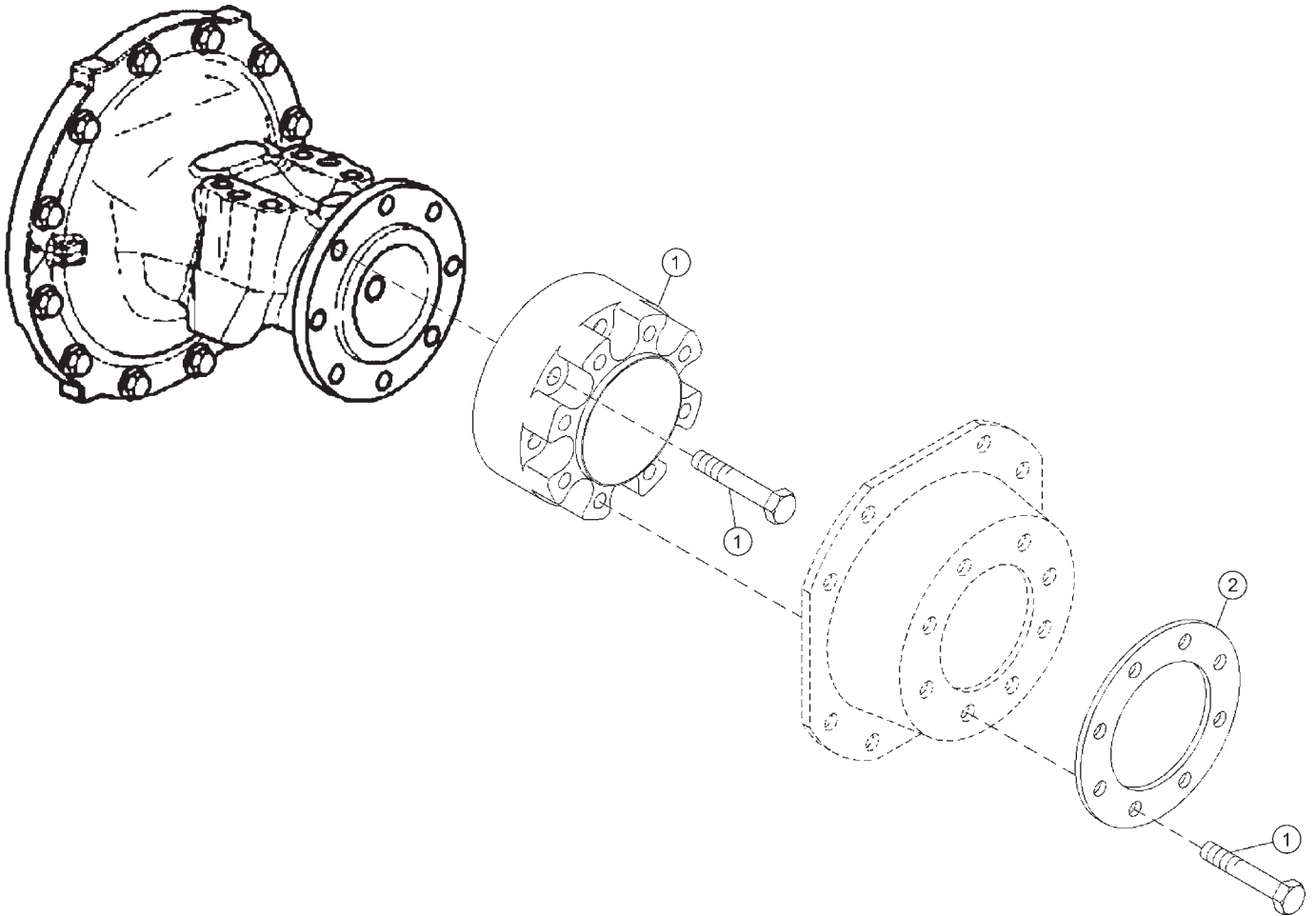

ITEM	PART NO.	QTY.	DESCRIPTION
1	06770025	1/2	KIT,SPCR,WHL,JD
2	*	*	JD WHEEL RING

OPTIONAL PUMP AND GRILL GUARD KIT

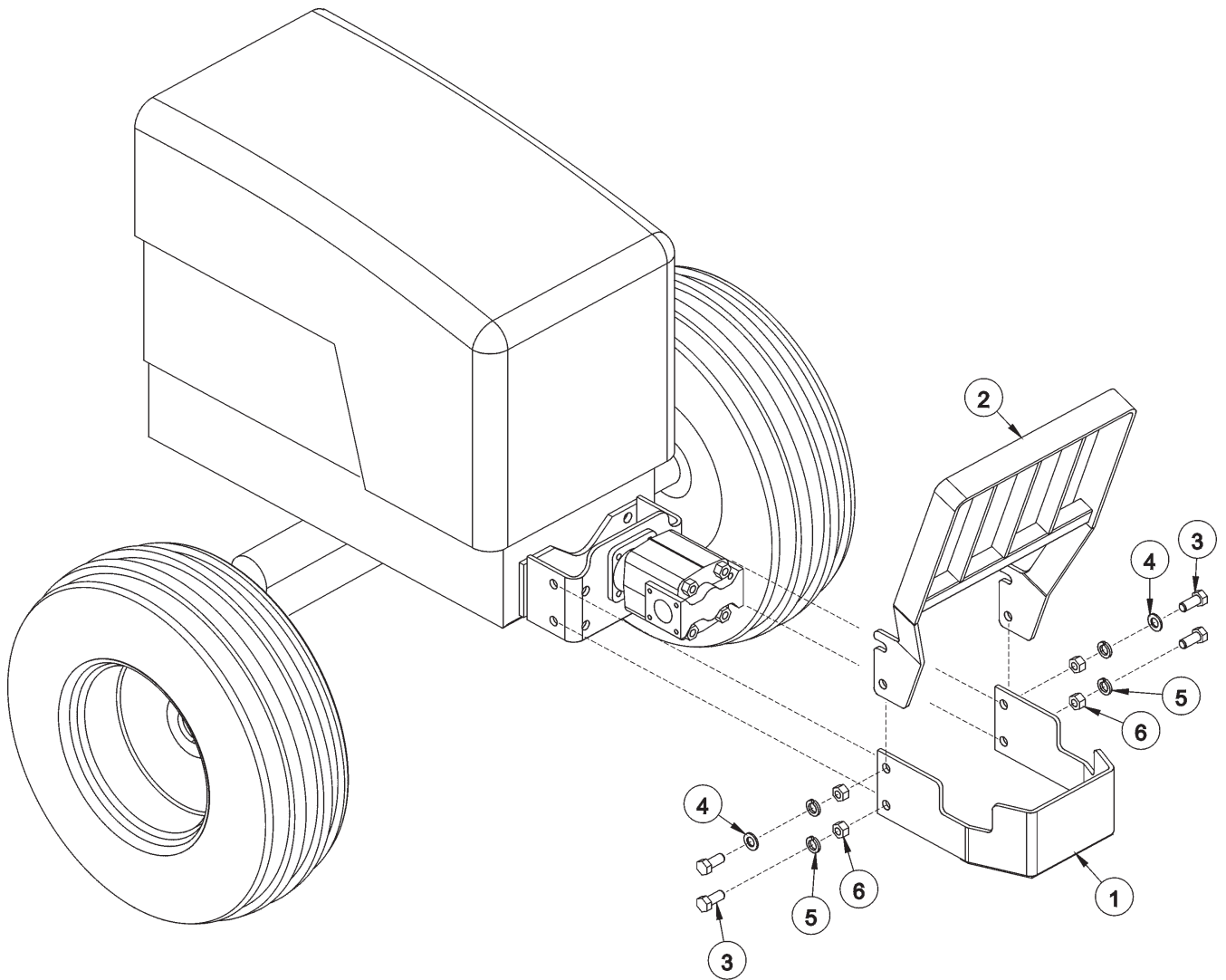

06200349

ITEM	PART NO.	QTY.	DESCRIPTION
1	32430	1	UNIVERSAL PUMP GUARD
2	32737	1	UNIVERSAL GRILL GUARD
3	21833	4	CAPSCREW - 3/4 X 2 1/4
4	22021	2	FLATWASHER - 3/4
5	21993	4	LOCKWASHER - 3/4
6	21825	4	HEX NUT - 3/4

SAFETY LIGHT ASSEMBLY

SAFETY LIGHT INSTALLATION

1. Remove ground wire (-) from the battery
2. Remove right rear tire
3. Remove the bottom cover from the tail light. Locate the wire connector on the tractor that has a brown & green wire
4. Remove panel from right rear of outside of cab under the window
5. Install light bar to mounting bracket
(Note: Wiring should be routed through the bracket & come out the hole on the top of the tube)
6. Install the light bar and bracket assembly in wheel well securing the three 1-1/4" bolts to the fender
7. Use the bracket as a guide to drill 2, 5/16" holes in the wheel well and install 2 remaining 1" capscrows and nylock nuts
8. Install the female 2-wire connector to the wires coming from the light making sure that the green wires are common
9. Reconnect the battery ground wire (-) and test for proper operation
(Note: The marker light should flash with hazard lights and the right turn signal. The light should burn steady with hazards and the left turn signal on.)
10. Reinstall all covers that were previously removed
11. Reinstall right side tire

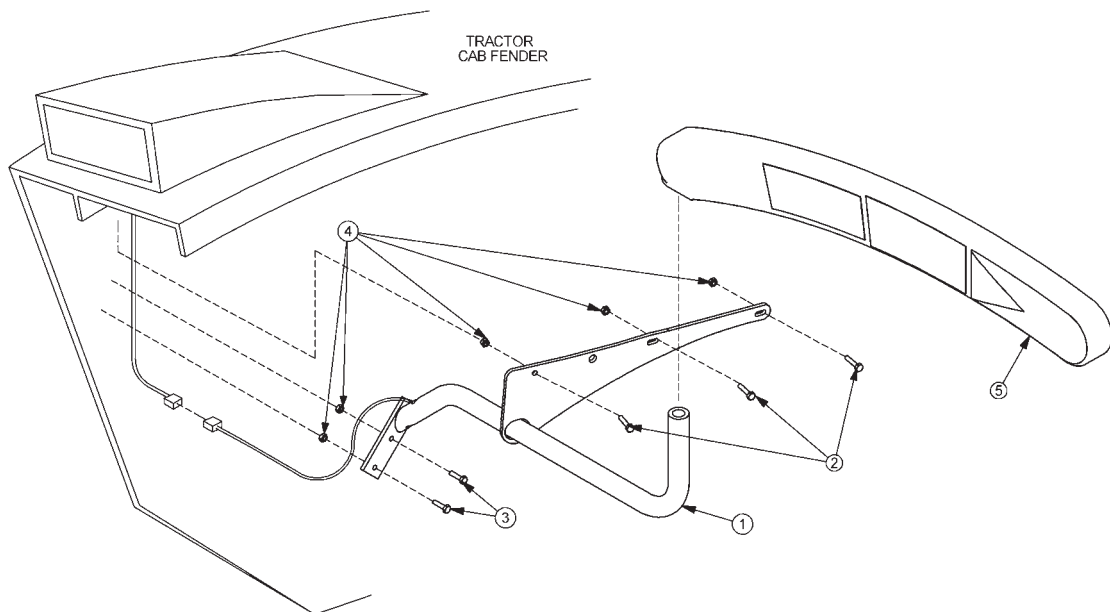

ITEM	PART NO.	QTY.	DESCRIPTION
1	34894	1	BRACKET, MOUNTING, JD72-7510,LIGHTING
2	21531	3	CAPSCREW, 1/4 x 1-1/4, NC
3	21530	2	CAPSCREW, 1/4 x 1, NC
4	21527	5	NYLOCK NUT, 1/4, NC
5	34859	1	MARKER LIGHT ASSEMBLY
*	6T1824	2	ZIP-TIE, 8" (NOT SHOWN)

COOLER ASSEMBLY

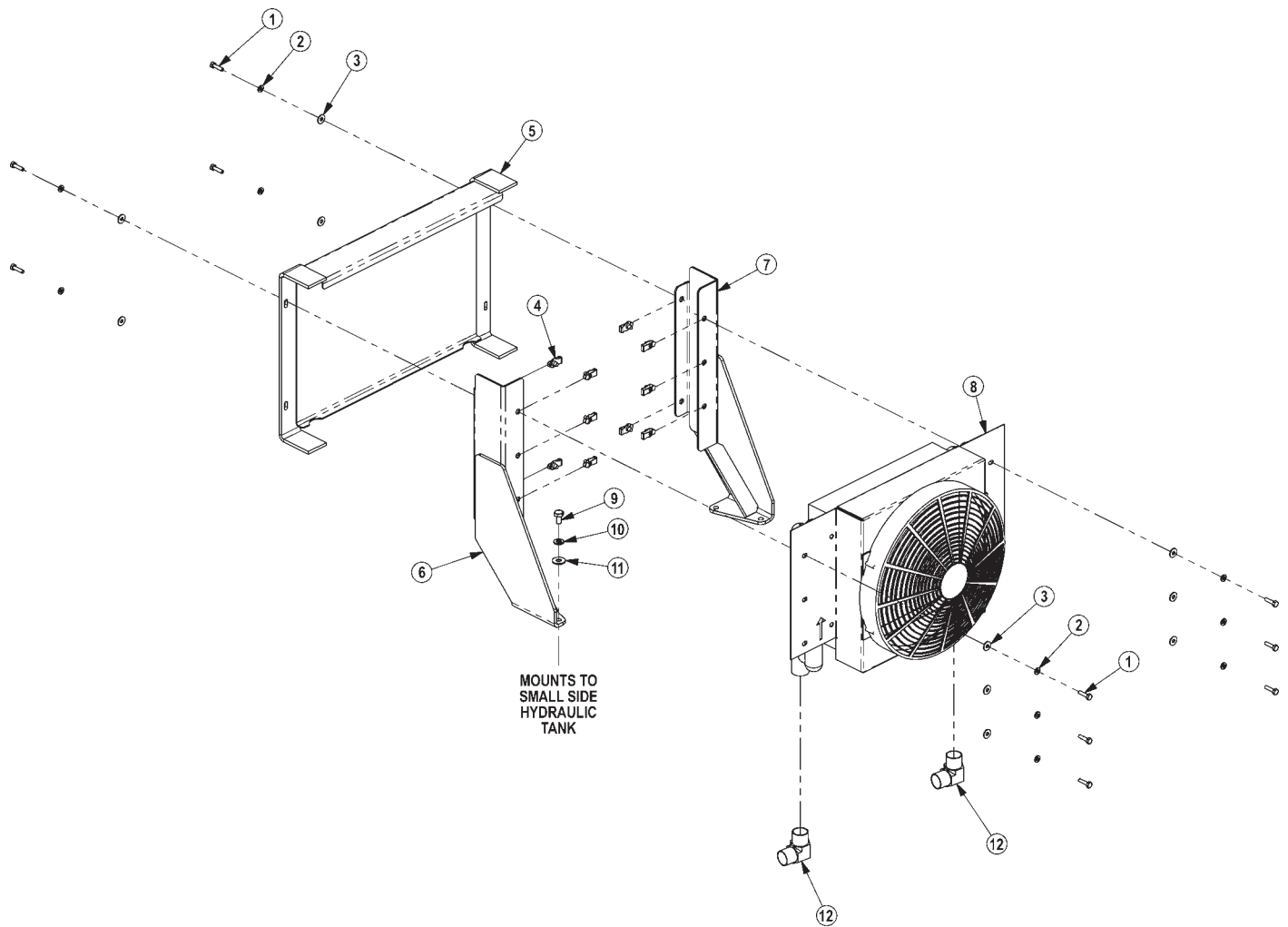

ITEM	PART NO.	QTY.	DESCRIPTION
1	21530	10	CAPSCREW,1/4 X1 NC
2	21986	10	LOCKWASHER,1/4
3	22014	10	FLATWASHER,1/4
4	35176	10	1/4 U-NUT
5	06370015	1	SCREEN,COOLER,FRNT
6	06380006	1	MNT,COOLER,BUMPER TANK,RH
7	06380007	1	MNT,COOLER,BUMPER TANK,LH
8	06510026	1	COOLER,FRONT MNT
*	06510029	1	FAN ASSEMBLY
*	06510038	1	CABINET,SINGLE FAN
*	06510039	1	COOLING COIL,SINGLE FAN
9	21629	4	CAPSCREW,3/8 X 3/4 NC
10	21988	4	LOCKWASHER,3/8
11	22016	4	FLATWASHER,3/8
12	34117	2	ELBOW,1MOR X 1MJ90,FORGED

SWITCHBOX ASSEMBLY

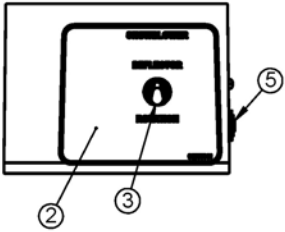
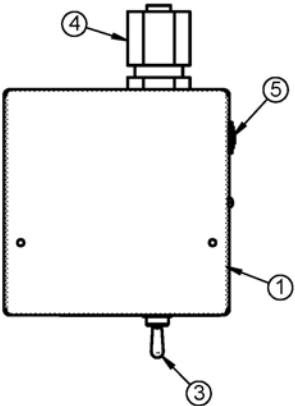
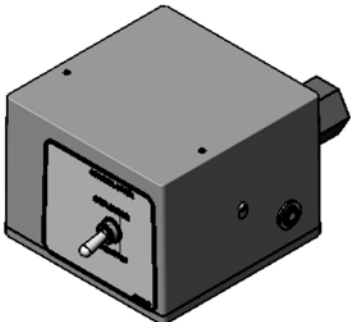
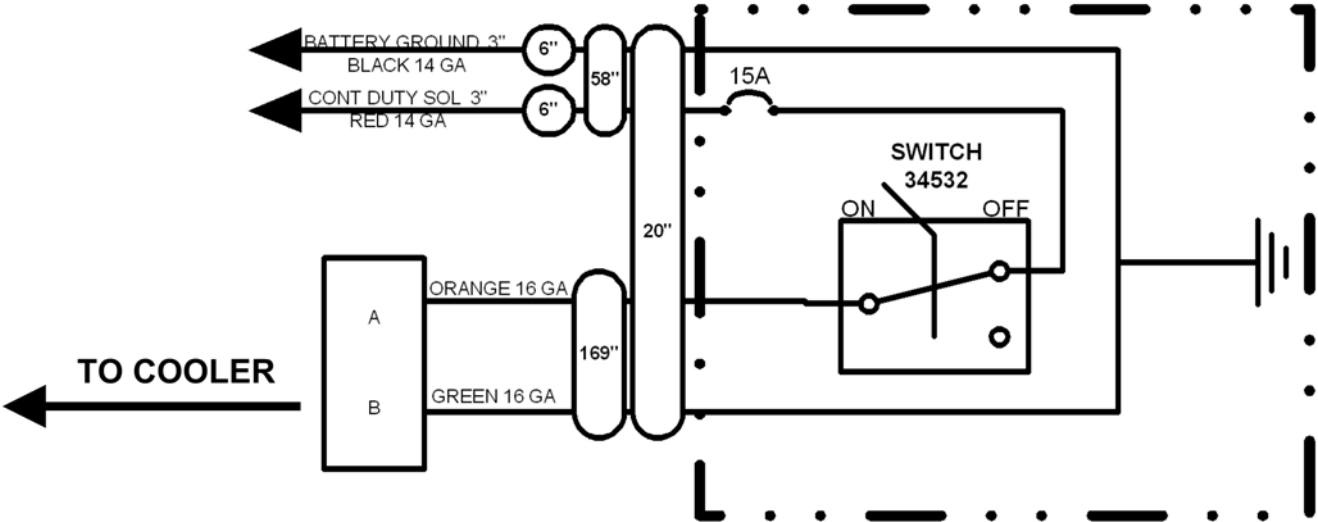

ITEM	PART NO	QTY	DESCRIPTION
1	06514019	1	SWBX,ALUM,BLK,06510225
2	06550041	1	DECAL,SWBX,06510225
3	34532	1	SWITCH,TRVL LCK
4	34540	1	STRAIN RELIEF,3/4,BLACK,NYLON
5	06514020	1	BREAKER,3A,SWBX

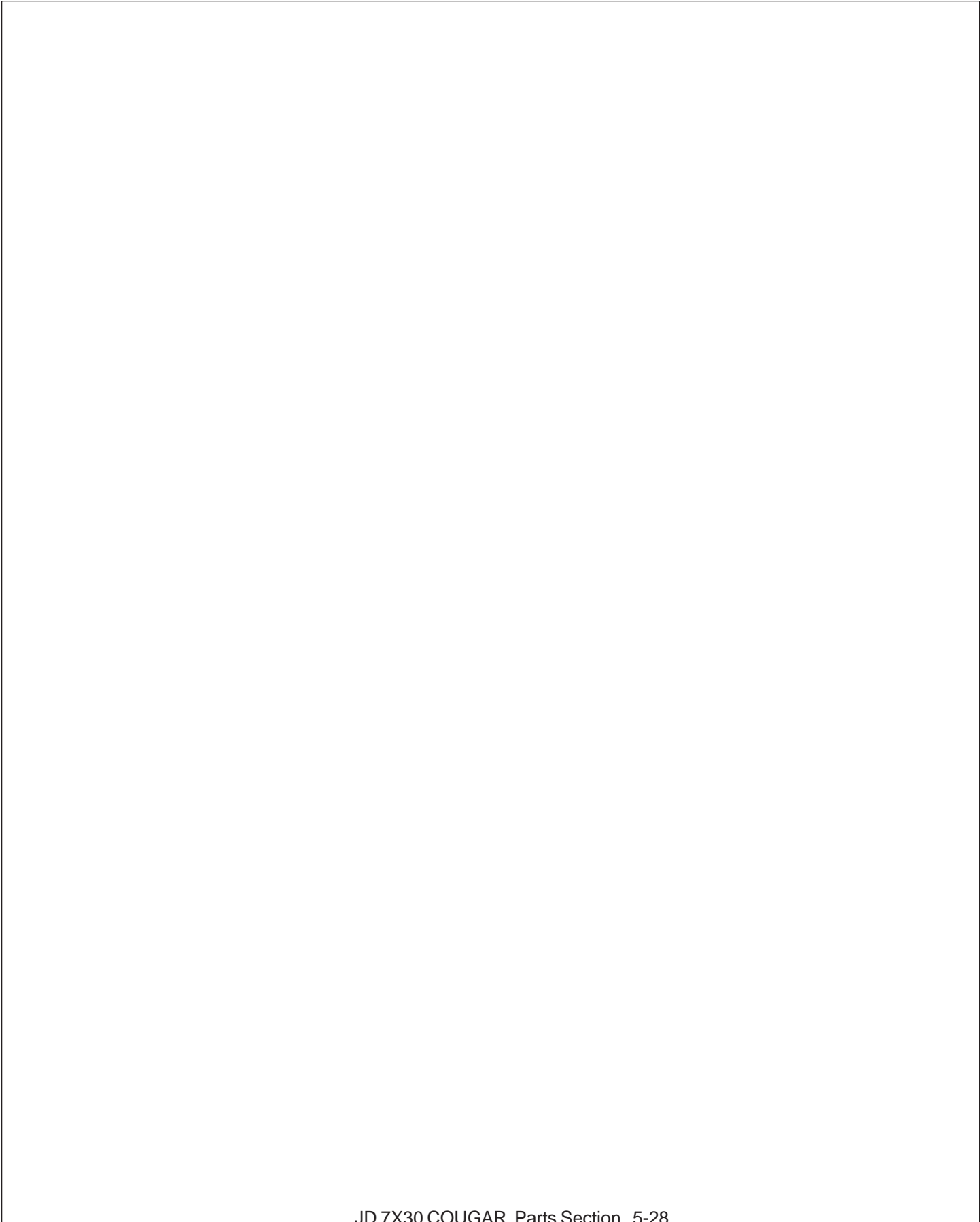
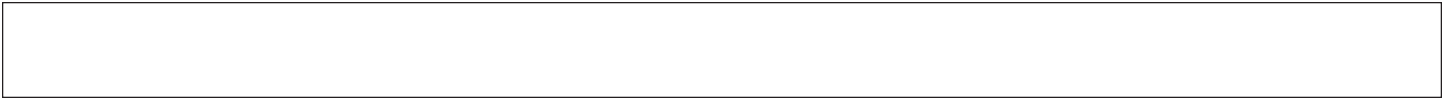

COUGAR BOOM MOWER

COMMON SECTION

TABLE OF CONTENTS

BOOM PARTS	PAGE
BOOM HOSE ROUTING	6-4
BOOM ARM ASSEMBLY	6-6
BOOM ARM HOSES & TUBES	6-8
SWIVEL ASSEMBLY	6-10
BOOM REST	6-11
60" ROTARY MOWER HEAD	6-12
ROTATING TREE ASSEMBLY	6-14
ROTARY MOWER BLADE BAR AND KNIVES	6-15
ROTARY MOWER PIVOT / BOOM ASSEMBLY	6-16
50" FLAIL MOWER HEAD ASSEMBLY	6-18
FLAIL MOWER DRIVE ASSEMBLY	6-20
FLAIL MOWER HYDRAULIC SHIELD ASSEMBLY	6-22
FLAIL MOWER PIVOT / BOOM ASSEMBLY	6-23
HYDRAULIC CYLINDERS	6-24
ROTARY MOWER SPINDLE	6-29
VALVE BREAKDOWNS	6-30
RESERVOIR TANK FILTER ASSEMBLY	6-36
FRONT HYDRAULIC PUMP	6-37
ROTARY MOWER MOTOR	6-38
FLAIL MOWER MOTOR	6-40
BOOM TRAVEL LOCK	6-42
HUSCO SWITCHBOX	6-43
SYSTEM SCHEMATIC	6-44
DAN FOSS SWITCHBOX	6-45
BRAKE VALVE	6-47
TROUBLESHOOTING	6-49

PARTS ORDERING GUIDE

The following instructions are offered to help eliminate needless delay and error in processing purchase orders for the equipment in this manual.

1. The Parts Section is prepared in logical sequence and grouping of parts that belong to the basic machine featured in this manual. Part Numbers and Descriptions are given to help locate the parts and quantities required.

2. The Purchase Order must indicate the **Name and Address** of the person or organization ordering the parts, **who should be charged**, and if possible, the **serial number of the machine** for which the parts are being ordered.

3. The purchase order must clearly list the **quantity of each part**, the complete and correct **part number**, and the basic **name of the part**.

4. The manufacturer reserves the right to substitute parts where applicable.

5. Some parts may be unlisted items which are special production items not normally stocked and are subject to special handling. Request a quotation for such parts before sending a purchase order.

6. The manufacturer reserves the right to change prices without prior notice.

NOTE: When ordering replacement decals, refer to the part numbers and descriptions listed in the safety section in the front of this manual.



1000

For maximum safety and to guarantee optimum product reliability, always use genuine **Tiger** replacement parts. The use of inferior replacement parts may cause premature or catastrophic failure which could result in serious injury or death.

Direct any questions regarding parts to:

Tiger Corporation
3301 N. Louise Ave.
Sioux Falls, SD 57107
1-800-843-6849
1-605-336-7900

BOOM HOSES ROUTING

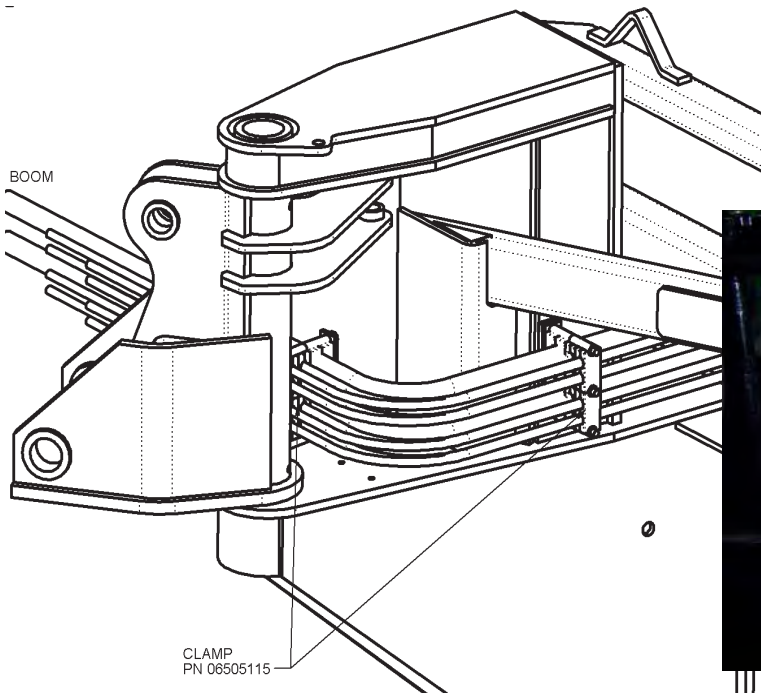

**BEFORE TIGHTENING
HOSES IN CLAMP,
MAKE SURE HOSES
CAN PASS THROUGH
CENTER POINT OF
BOOM PIN. THIS WILL
ENSURE PROPER
HOSE LENGTH FOR
ALL BOOM POSITIONS.**

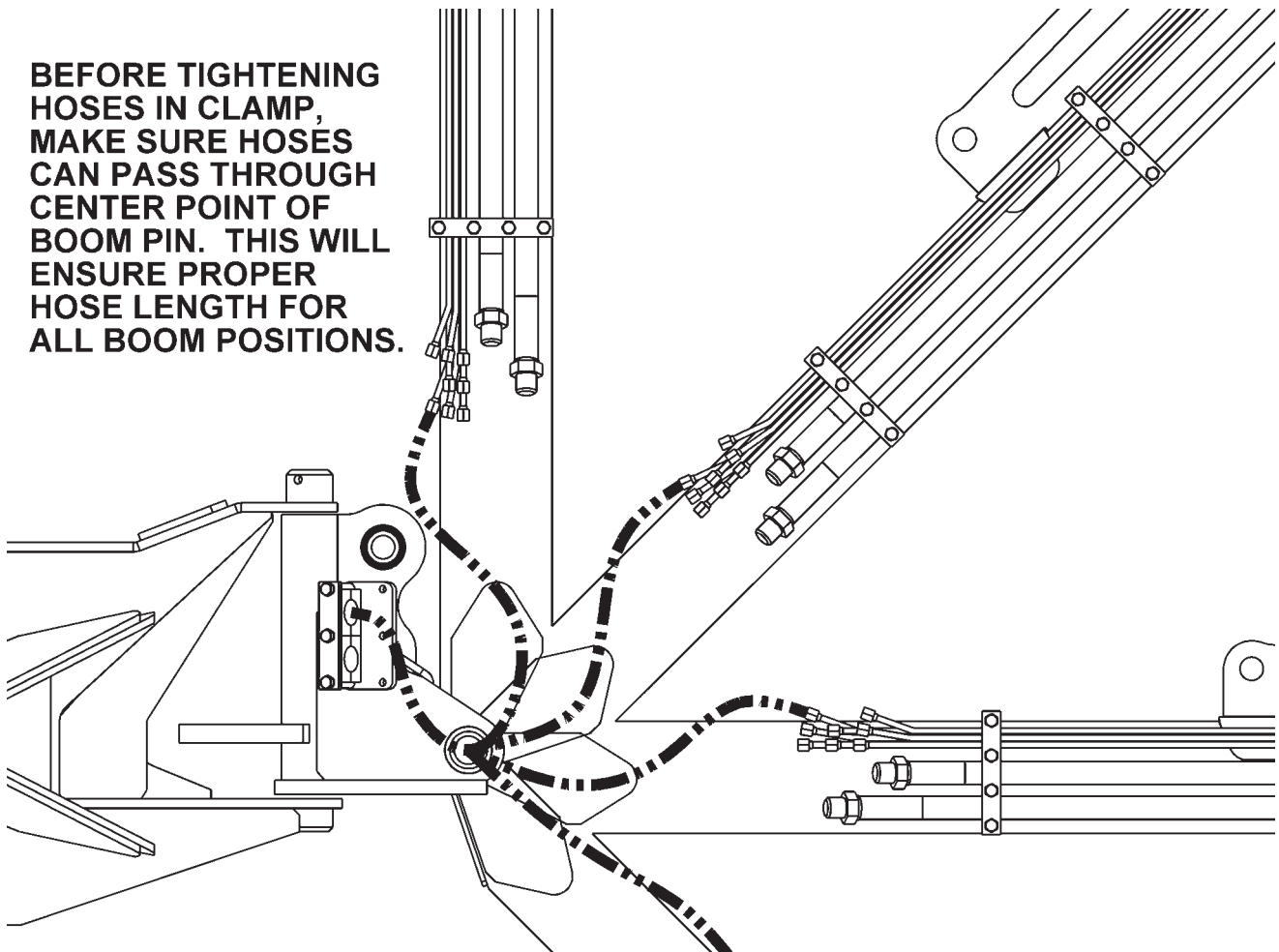

BOOM HOSES ROUTING

WARNING NOTE: The sudden release of hydraulic pressure could cause the sudden movement of very heavy parts. Anyone in the way of these parts could be severely hurt or killed. DO NOT ALLOW these hydraulic hoses to BREAK or BURST in order to prevent hydraulic failure. Make sure the hoses do not pinch or stretch as boom moves. Measure TWICE, check TWICE then proceed with caution.

Connect the hoses to the preformed tubes and move the boom arm to the farthest forward position. Arrange the hoses in the clamp as shown to the left, with the 1" motor hoses to the outside, and loosely connect to the swivel. Next, make sure there is enough slack for all hoses to pivot at the joint where the main boom arm bends in the swivel and tighten the hoses in the clamp.

Arrange the hoses in the clamp that attaches to the main frame as shown to the left & below, with the 1" motor hoses closest to the main frame. Pull the hoses snug from the swivel to the main frame clamps, when main boom is fully forward, and tighten the hoses in the clamp.

Make sure the 1" motor hoses do not kink as the boom arm is moved into the stowing position. If this happens the motor hoses will have to be tightened, because there is too much hose between clamps.

LOCATION OF HOSES IN CLAMPS NEEDS TO BE MAINTAINED TO ENSURE PROPER LENGTHS AND REACH

CONFIGURATION OF CLAMP ON SWIVEL

CONFIGURATION OF CLAMP ON MAINFRAME

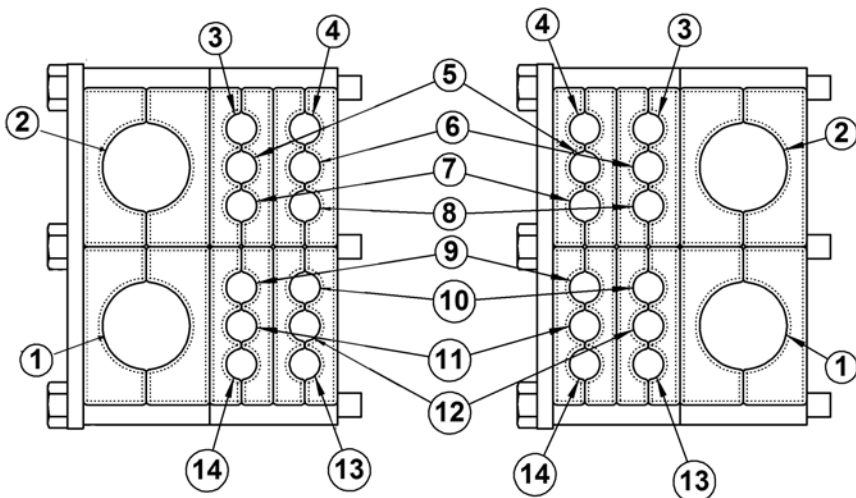

1. MOWER PRESSURE
2. MOWER RETURN
3. MAIN BOOM CYLINDER BUTT
4. MAIN BOOM CYLINDER GLAND
5. SECONDARY BOOM CYLINDER BUTT
6. SECONDARY BOOM CYLINDER GLAND
7. DECK ROLL CYLINDER BUTT
8. DECK ROLL CYLINDER GLAND
9. DECK SHIELD CYLINDER BUTT
10. DECK SHIELD CYLINDER GLAND
11. DECK ROTATION CYLINDER BUTT
12. DECK ROTATION CYLINDER GLAND

BOOM ASSEMBLY

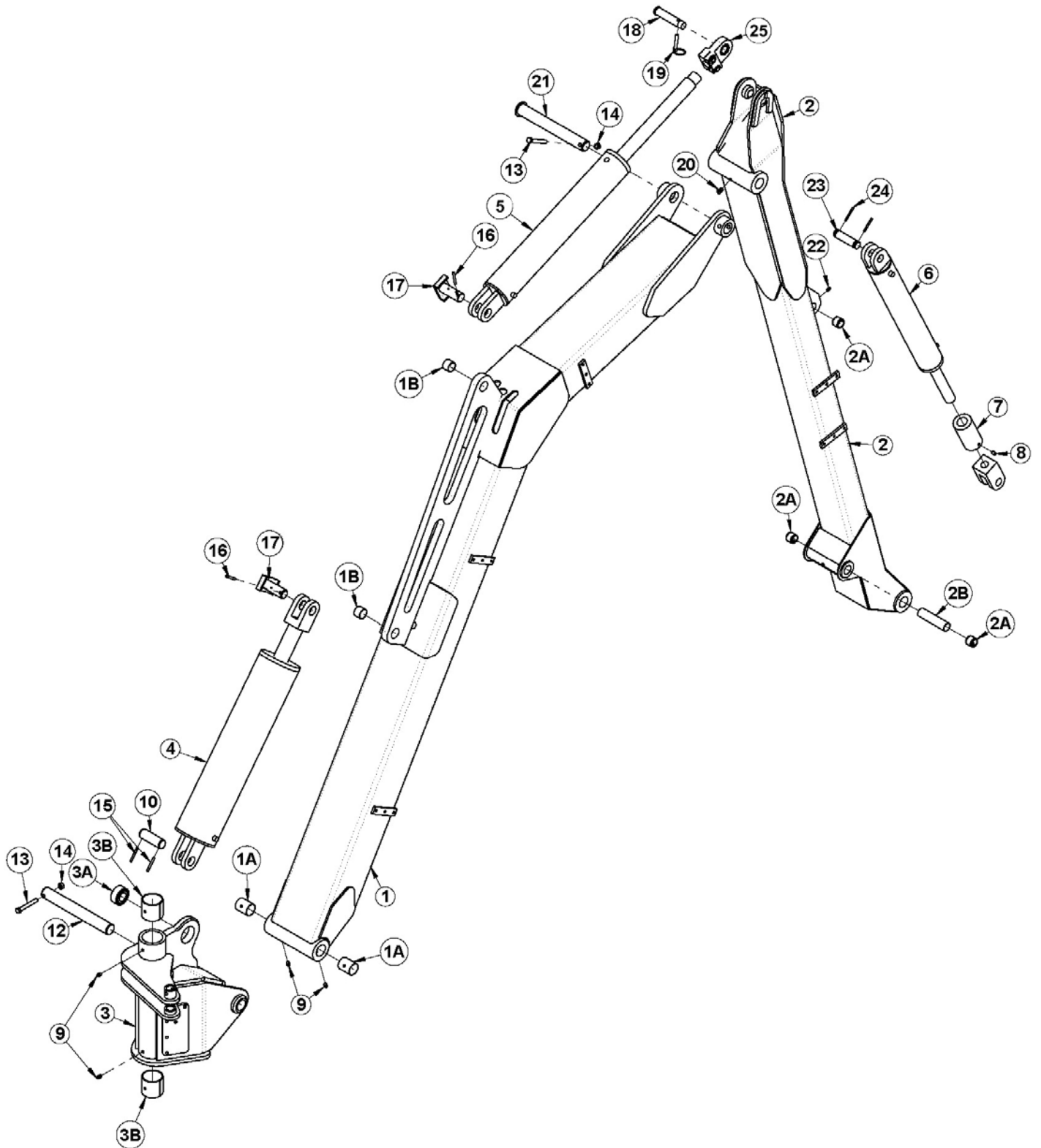

BOOM ASSEMBLY

ITEM	P/N	QTY.	DESCRIPTION
1	06700032	1	BOOM,MAIN,IT,W/BEARINGS
	06310010	1	WELDMENT,BOOM,MAIN
1A	32321	2	BEARING,DX,1 1/2X2LONG
1B	TB1044	2	BUSHING,1-1/4
2	06700094	1	BOOM,SEC,ASSY,EXTENDED
	30072C	1	WELDMENT,BOOM,SEC
2A	TB3010	3	BUSHING
2B	TB1035	1	SPACER
3	06700150	1	SWIVEL,TRB60,ROT,22',ASSY
	06310080	1	WELDMENT,SWIVEL
3A	06520303	1	BEARING,SPHERICAL
3B	32322	2	BEARING,DX,2 1/2X2 1/2LONG
4	06501020	1	CYLINDER,5x20,1.25PIN,BUTT,2.0
5	06501022	1	CYLINDER,4x20,1.25PIN,BUTT,2.0
6	06501023	1	CYLINDER,3x18,2.0
7	06430140	1	SPACER,2.50x1.39x4.75,TAPPED
8	6T2272	1	SETSCREW, 3/8 X 1/2
9	6T3211	4	GREASE ZERK, 1/8" X STR
10	06420100	1	PIN,2.25 x 3.69,NIT
12	06420022	1	PIN,1.50x12.00,W/.44 HOLES,NIT
13	21688	2	CAPSCREW, 7/16 x 3 1/4,NC
14	21677	2	NYLOCK NUT,7/16 NC
15	TB1023	2	ROLLPIN,7/32" X 2"
16	6t3014	2	ROLL PIN, 1/4" x 2"
17	TB1045B	2	PIN,PRIMARY CYL (BRKT HEAD)
18	TB1036	1	PIN,SEC BOOM SWIV 1X4-11/16"
19	TF1143	1	PIN, LYNCH, 7/16" x 2"
20	6T3210	1	GREASE ZERK, 1/8 X 90
21	TB1025	1	PIN,SEC BOOM SWIV 1-1/2" X 12"
22	6T3207	1	GREASE ZERK,1/4"
23	TB1033	1	PIN,CLEVIS,1x4
24	06537021	2	ROLL PIN, 5MM x 50MM
25	30172	1	CLEVIS

PREFORMED TUBES & HOSES

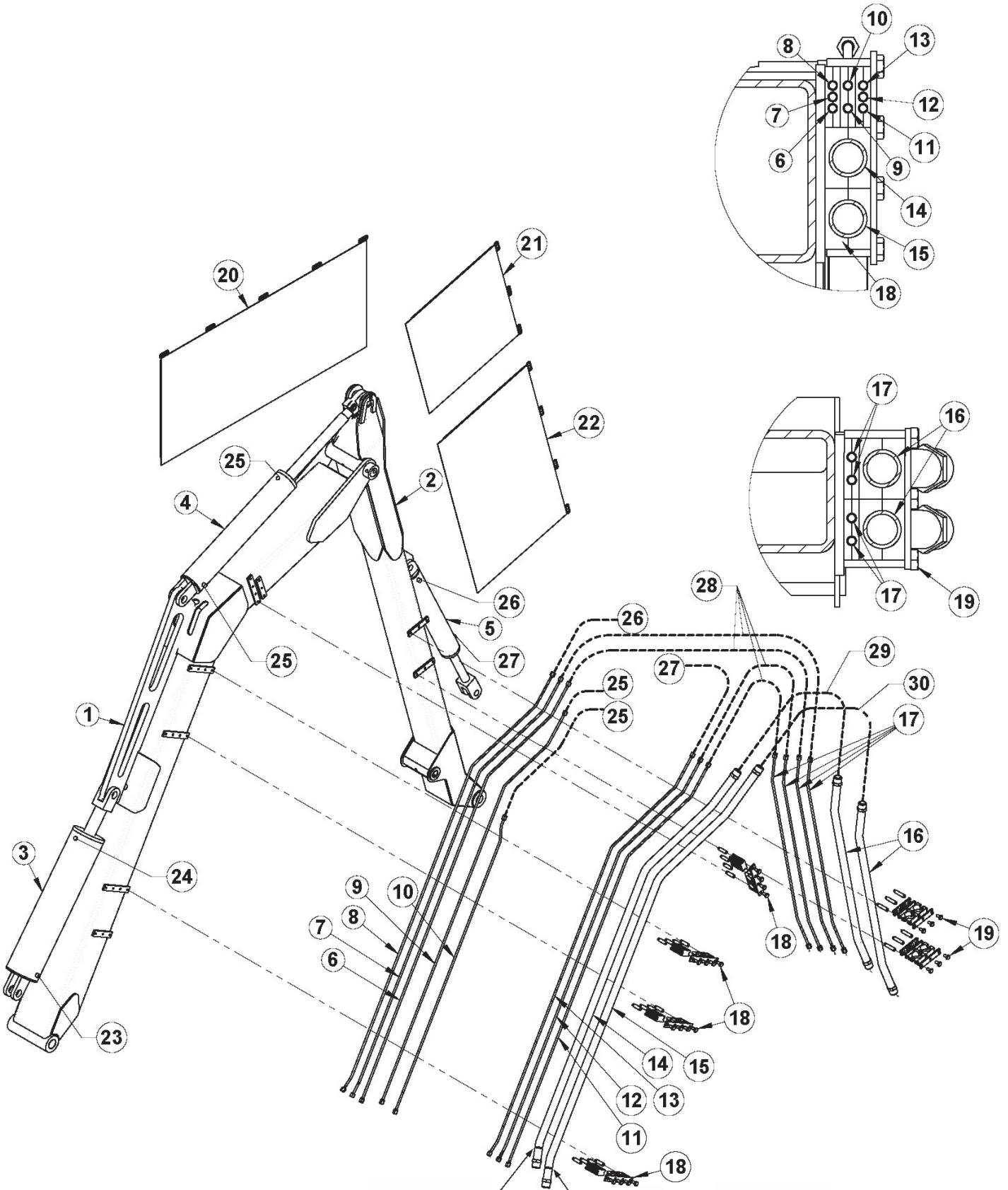

BLUE DECAL STRIP
 RETURN LINE
 ROTARY MOWER

RED DECAL STRIP
 PRESSURE LINE
 ROTARY MOWER

Cougar Common Section 6 - 8

PREFORMED TUBES & HOSES

ITEM	P/N	QTY.	DESCRIPTION
1	06700032	1	BOOM,MAIN,IT,W/BEARINGS
2	06700094	1	BOOM,SEC,ASSY,EXTENDED
3	06501020	1	CYLINDER,5x20,1.25PIN,BUTT,2.0
4	06501022	1	CYLINDER,4x20,1.25PIN,BUTT,2.0
5	06501023	1	CYLINDER,3x18,2.0
6	06506013	1	PRFRMD,1,MAIN,REAR STOW
7	06506014	1	PRFRMD,2,MAIN,REAR STOW
8	06506015	1	PRFRMD,3,MAIN,REAR STOW
9	06506016	1	PRFRMD,4,MAIN,REAR STOW
10	06506017	1	PRFRMD,5,MAIN,REAR STOW
11	06506018	1	PRFRMD,6,MAIN,REAR STOW
12	06506019	1	PRFRMD,7,MAIN,REAR STOW
13	06506020	1	PRFRMD,8,MAIN,REAR STOW
14	06506021	1	PRFRMD,9,MAIN,REAR STOW
15	06506022	1	PRFRMD,10,MAIN,REAR STOW
16	30169	2	TUBE,PREFORMED (HP)
17	34103	4	TUBE,PREFORMED,5/16,EXT,SEC
18	06505019	4	CLAMP KIT,TUBE,1.25x2,.31x8,4PST
19	30111	2	CLAMP KIT,TUBE,1.25x2,.31x4,3PST
20	06505020	1	COVER,HOSES,KNUCKLE,RS
21	06505021	1	COVER,HOSES,SEC,RS
22	06505022	1	COVER,HOSES,ROLL,RS
23	06500149	1	HOSE, 1/4 x 220
24	34631	1	HOSE, 1/4 x 126
25	34052	2	HOSE, 1/4 x 66
26	34051	1	HOSE, 1/4 x 93
27	34050	1	HOSE, 1/4 x 63
28	34104	4	HOSE, 1/4 x 42
29	06500254	1	HOSE, 1/4 x 45
30	24488	1	HOSE, 1/4 x 40

TRACTOR MOUNT KIT - BOOM SWIVEL

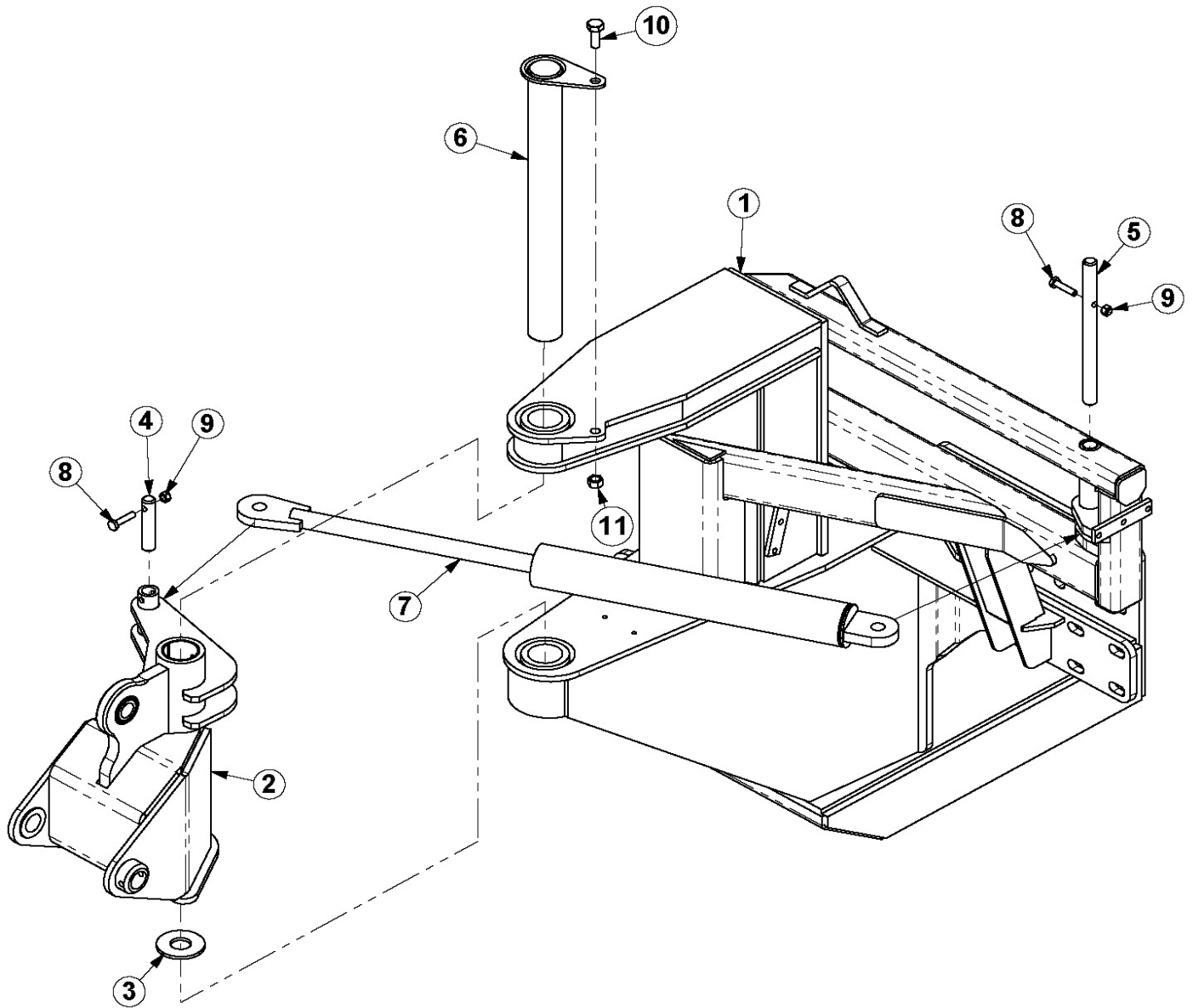

ITEM	P/N	QTY.	DESCRIPTION
1	-	1	MNFRM
2	06700150	1	SWIVEL,TRB60,ROT,22',ASSY
3	06520250	1	BEARING,WASHER,SWING
4	32380	1	PIN,CYL,1",SWIVEL,SABER
5	33710	1	PIN,CYL,1",SWIVEL,SABER
6	32381	1	PIN,2 1/2",SWIVEL,SABER
7	33705	1	CYLINDER,3 X 17-1/2
8	21683	2	CAPSCREW,7/16 X 2,NC
9	21677	2	NYLOCK NUT,7/16 NC
10	21782	1	CAPSCREW, 5/8 X 1-3/4,NC
11	21777	1	NYLOCK HEX NUT, 5/8

BOOMREST ASSEMBLY - 3 POINT STOW

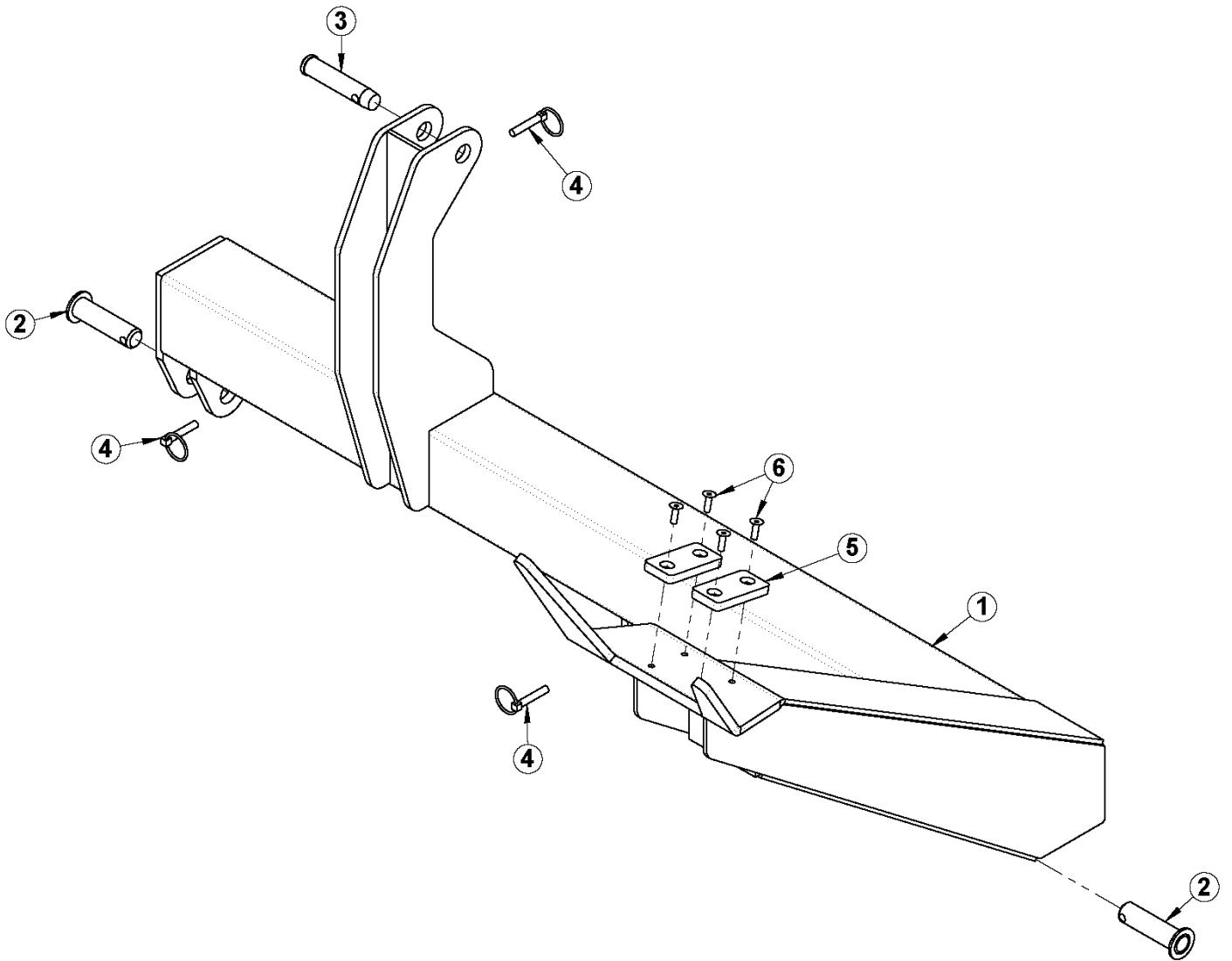

ITEM	PART NO.	QTY.	DESCRIPTION
1	06310082	1	BOOMREST,STD,3PNT
2	TF1120	2	PIN,(CAPPED),1-1/8 X 3-7/8
3	TB1036	1	PIN,SEC BOOM SWIV 1X4-11/16
4	TF1143	3	PIN,LYNCH 7/16 X 2
5	06520078	2	STRIP,REST
6	28734	4	CAPSCREW,FLT/SKT HD,3/4x1NC

60" ROTARY MOWER ASSEMBLY

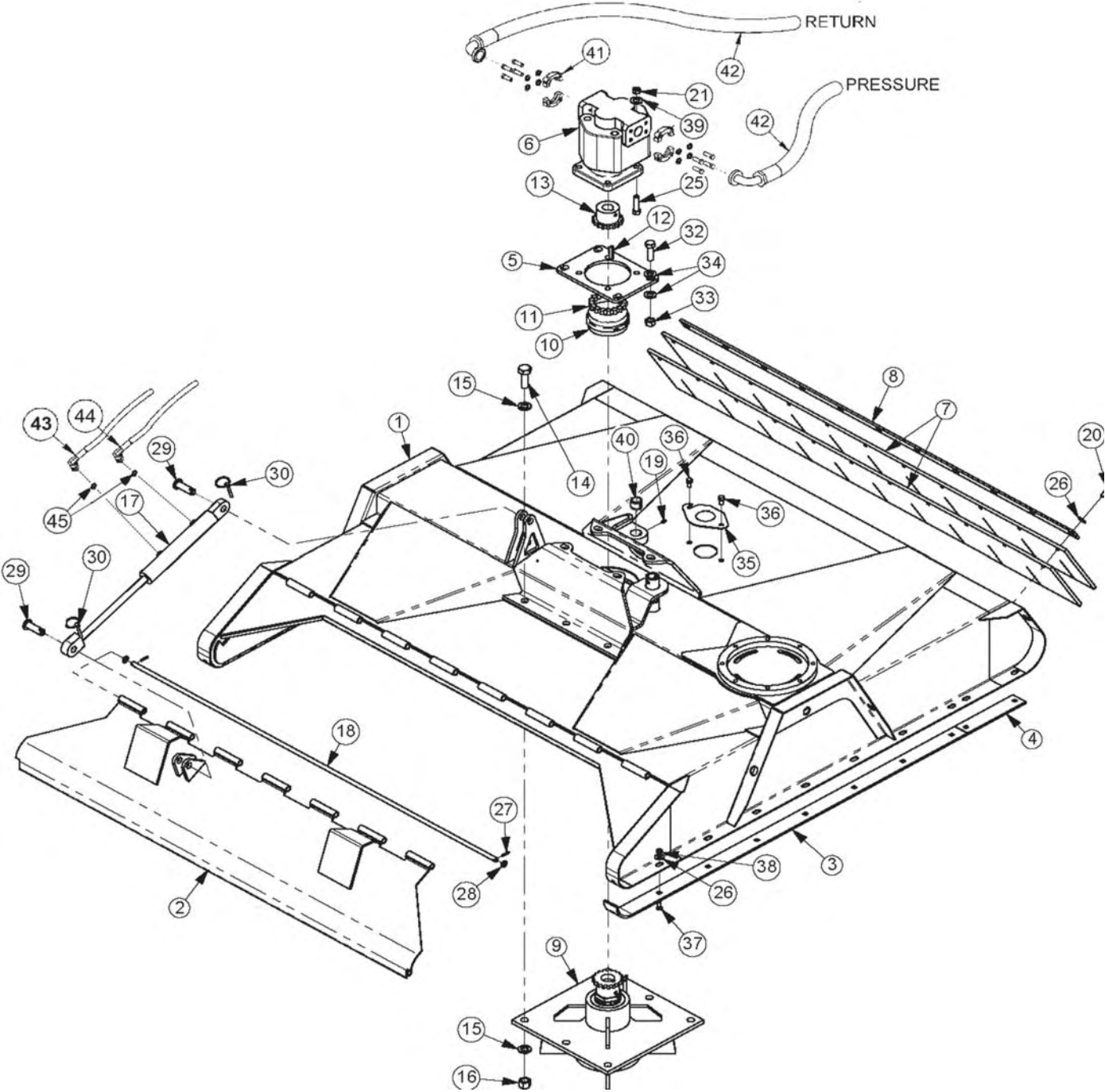

60" ROTARY MOWER ASSEMBLY

ITEM	P/N	QTY.	DESCRIPTION
1	06320160	1	DECK,TRB60,ROT,CPLT
2	06320162	1	SHIELD,TRB60,ROT
3	33777	2	SKID SHOE,50" RTRY
4	06401245	2	SKID SHOE,TRB60,ROT
5	33776	1	MOTOR MOUNT,PLATE,50" RTRY
6	06504011	1	MOTOR,(M365-1 1/2" GEAR)
7	06520238	2	FLAP, DEFLECTOR
8	06t0823	1	BAR, FLAP, TM60
9	6T1024H5	1	SPINDLE ASSY, CPLT, HD, 5/8 HOLES
10	6T1033	1	COVER,COUPLING
11	6t1029	1	CHAIN,COUPLING (5016)
12	TF1124	1	KEY,5/16 SQ X 1-1/2 RND
13	21223	1	SPROCKET, 1-1/4" BORE
14	33879	6	CAPSCREW, 3/4 x 2 1/4,NF GR 8
15	33880	12	FLATWASHER,3/4",GR 8,SAE
16	6T2413	6	HEX NUT,3/4,NF,GR 8
17	33785	1	CYL,1 1/2 x 8
18	06420139	1	PIN,HINGE,TRB60,ROT
19	6T3207	1	GREASE ZERK,1/4"
20	21633	11	CAPSCREW, 3/8x1 3/4,NC,GR8
21	21727	4	NYLOCK NUT, 1/2
22	21730	7	CAPSCREW, 1/2 X 1 1/4,NC
23	21731	7	CAPSCREW, 1/2 X 1 1/2,NC
25	21733	4	CAPSCREW, 1/2 x 2,NC
26	22016	31	FLATWASHER,3/8",GR8
27	6T3017	2	ROLLPIN,3/16" X 1"
28	33924	2	RETAINING RING,EXTERNAL,1/2"
29	33984	2	PIN,SHIELD,50"
30	RD1032	2	PIN,LYNCH 1/4" X 2"
32	6T2290	4	CAPSCREW,5/8x2,NF GR 8
33	6T2408	4	HEX NUT, 5/8, NF
34	33764	8	FLATWASHER,5/8",GR 8,SAE
35	33779	1	PLATE,COVER,KNF HOLE
36	33881	2	CAPSCREW,FLG, 3/8 x 3/4,NC
37	6t2270	20	PLOW BOLT,3/8x1,NC,GR5
38	21625	20	HEX NUT,3/8",NC
39	06533004	4	FLATWASHER
40	TB3010	1	BUSHING
41	TF4852	2	FLANGE KIT
42	06500458	2	HOSE,1x95, PRESSURE (RED DECAL STRIP)
	06500458	*	HOSE,1x95, RETURN (BLUE DECAL STRIP)
43	33601	1	HOSE,1/4x111
44	06500480	1	HOSE,1/4x107
45	06503057	2	ADAPTER,1/4ORBx3/8MJ

60" ROTARY MOWER TREE ASSEMBLY

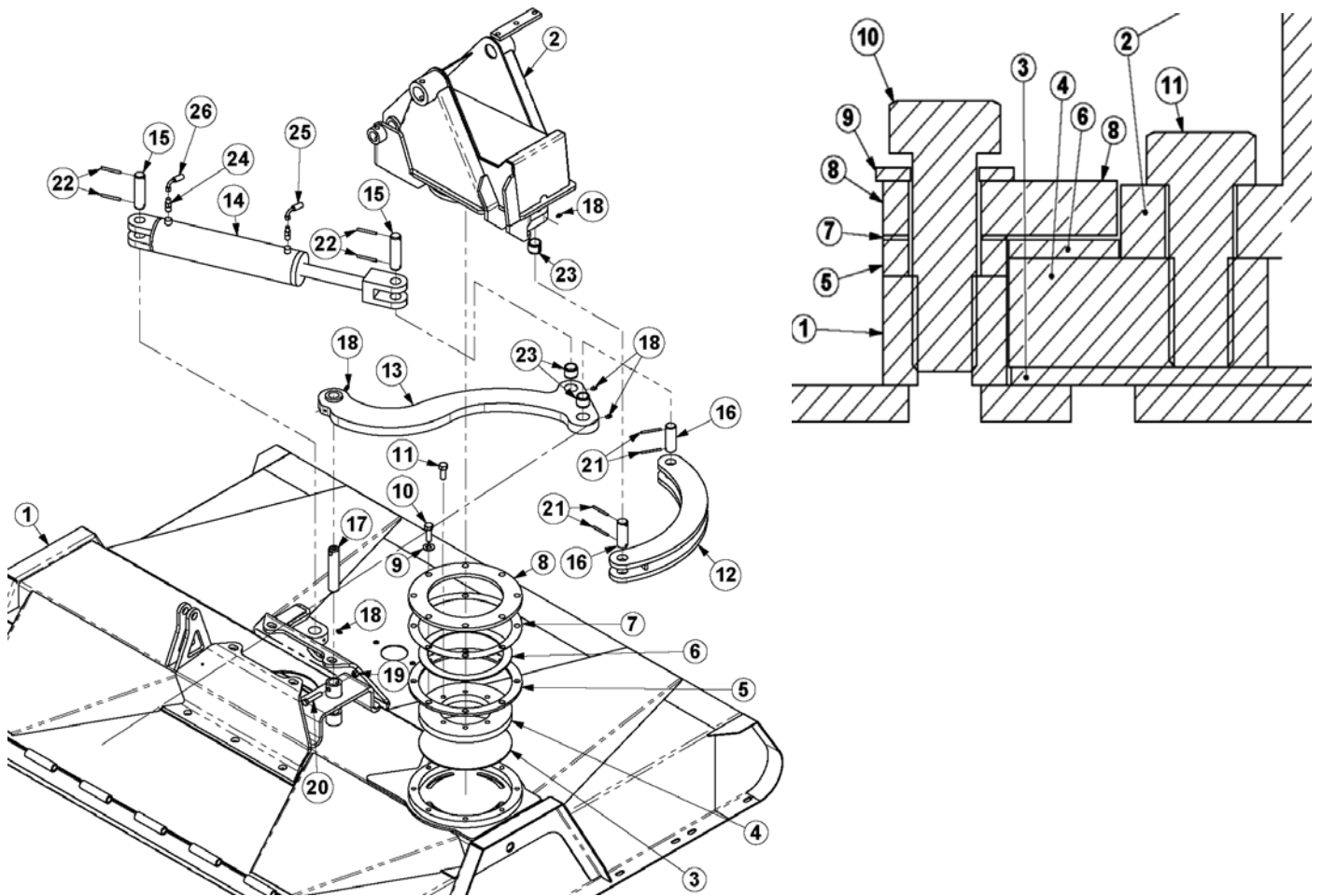

ITEM	P/N	QTY.	DESCRIPTION
1	06320160	1	DECK,TRB60,ROT,CPLT
2	06320163	1	TREE,TRB60,ROT
3	06497010	1	PAD,UHMW,06320163
4	06401250	1	RING,CAPTURE,06320163
5	06401251	1	RING,BOLT,06320164
6	06497011	1	RING,UHMW,06320163
7	06401253	1	RING,SHIM,06320164
8	06401252	1	RING,BOLT,06320164
9	06533004	16	FLAT WASHER,1/2,SAE,GR 8
10	6T2279	8	CAPSCREW, 1/2 X 1 1/2,NC,GR8
11	21730	8	CAPSCREW, 1/2 X 1 1/4,NC,GR8
12	06320164	1	LINKAGE,1,06320163
13	06741071	1	LINKAGE,2,06320163,ASSY
14	06501021	1	CYLINDER,3x10,2.0
15	06420014	2	PIN,1.00x3.84,W/.22 HOLES,NITRIDE
16	06420130	2	PIN,1.00.2.89,W/.19 HOLES
17	35191	1	PIN,SWIVEL,1x5,TRUCKAT
18	6T3207	5	GREASE ZERK,1/4"
19	21627	1	NYLOCK NUT,3/8",NC
20	21634	1	CAPSCREW, 3/8 x 2,NC
21	06537021	4	ROLL PIN, 5MM x 50MM
22	TB1023	4	ROLLPIN,7/32" X 2"
23	TB3010	1	BUSHING,1
24	33271	2	ADAPTER,1/2MORx3/8MJ
25	06500480	1	HOSE,#4x107
26	06500481	1	HOSE,#4x97

60" ROTARY BLADE BAR AND KNIVES

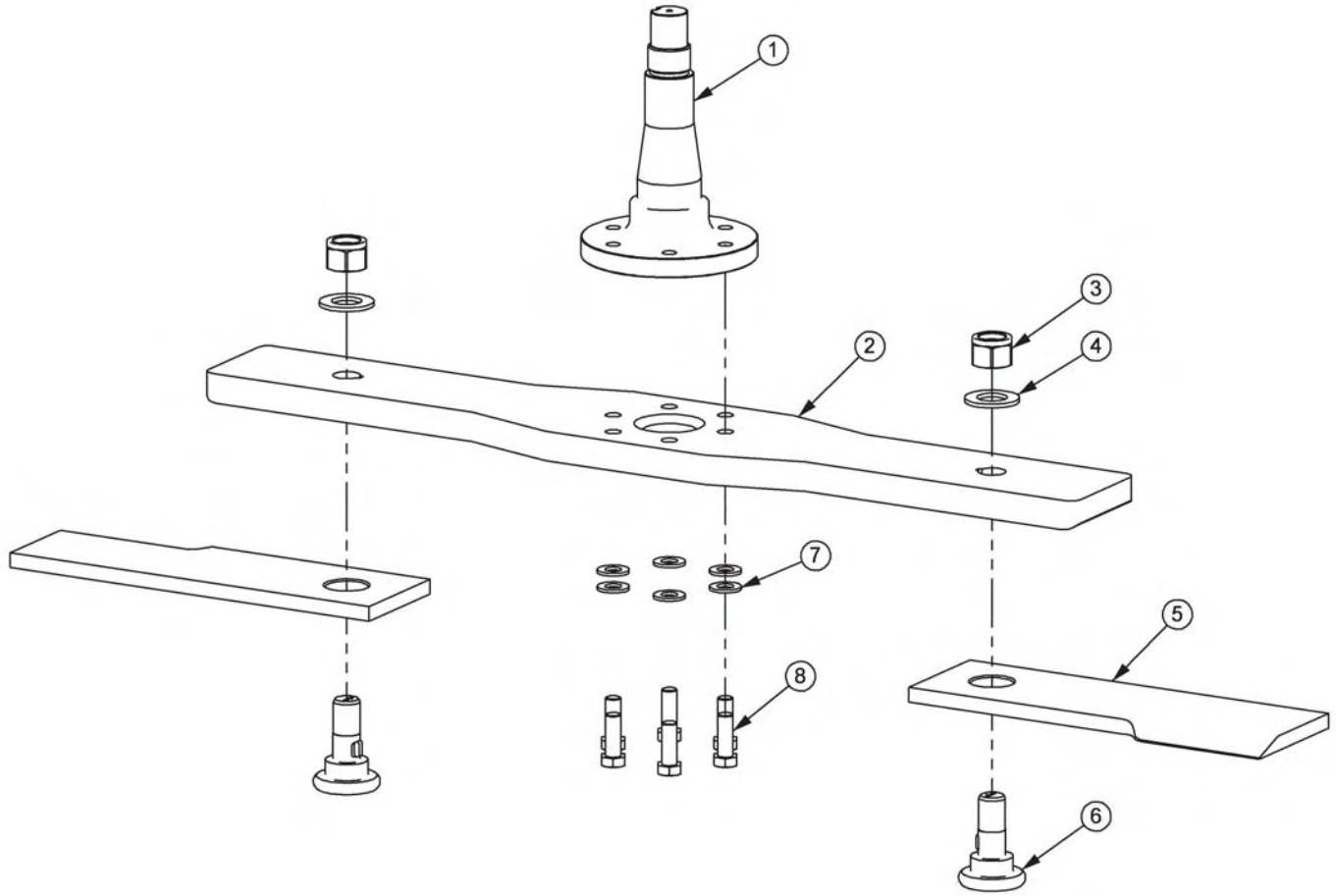

ITEM	PART NO.	QTY.	DESCRIPTION
1	PT1018H5	1	SPINDLE
2	06400690	1	BAR, BLADE, RTRY60
3	6T1023R	2	KNIFE MTG NUT, 1-1/8, NYLOCK, NF
4	06533002	2	FLATWASHER, 1-1/8, GR8
5	06521001	2	KNIFE, 5/8
*	06521006	AVAIL	KNIFE, DOUBLE EDGE
6	06538000	2	KNIFE MTG BOLT, 5/8 SHOULDER
7	33764	6	FLATWASHER, 5/8, GR 8, SAE
8	6T2259	6	CAPSCREW, 5/8 x 1-3/4, NF, GR8

60" ROTARY MOWER BOOM PIVOT ASSEMBLY

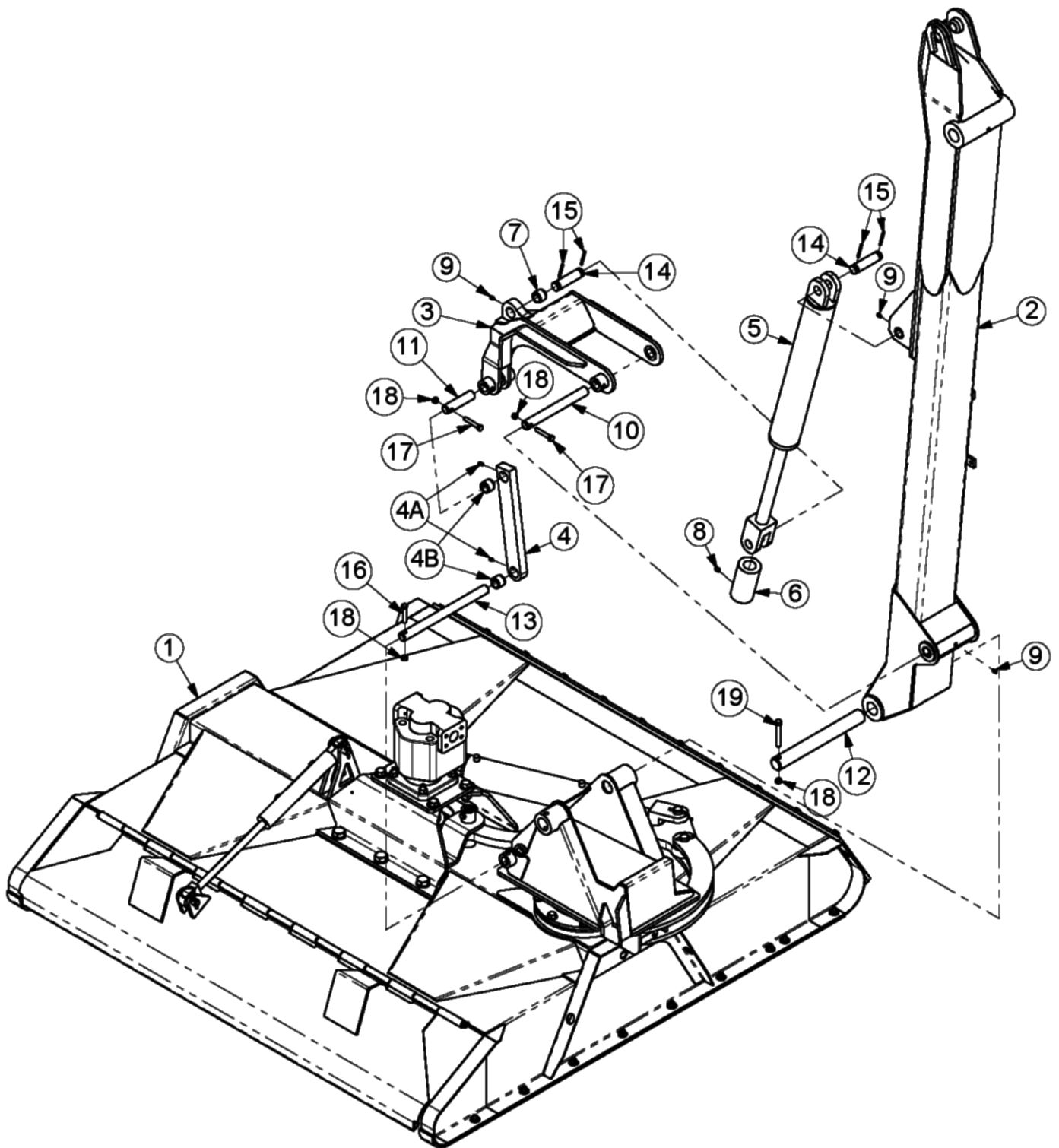

60" ROTARY MOWER BOOM PIVOT ASSEMBLY

ITEM	P/N	QTY.	DESCRIPTION
1	06741070	1	RTRY,TRB60,ROT,CPLT
2	06700094	1	BOOM,SEC,ASSY,EXTENDED
3	TB1032	1	PIVOT ASSY
4	TB1028	1	ARM, PIVOT W/BUSHINGS & ZERKS
5	06501023	1	CYLINDER,3x18,2.0
6	06430140	1	SPACER,2.50x1.39x4.75,TAPPED
7	TB3010	1	BUSHING,1
8	6T2272	1	SETSCREW, 3/8 X 1/2
9	6T3207	3	GREASE ZERK,1/4"
10	TF3097	1	PIN,DECK PVT ARM 1X9-1/2
11	TB1030	1	PIN,PVT ARM 1" X 4" CAPPED
12	33985	1	PIN,BOOM,50"
13	35191	1	PIN,BOOM,50"
14	TB1033	2	PIN,CLEVIS,1x4
15	06537021	4	ROLL PIN, 5MM x 50MM
16	21634	1	CAPSCREW, 3/8 x 2,NC
17	21635	2	CAPSCREW,3/8x2 1/4,NC
18	21627	4	NYLOCK NUT,3/8",NC
19	21687	1	CAPSCREW, 7/16 x 3,NC

50" FLAIL MOWER ASSEMBLY

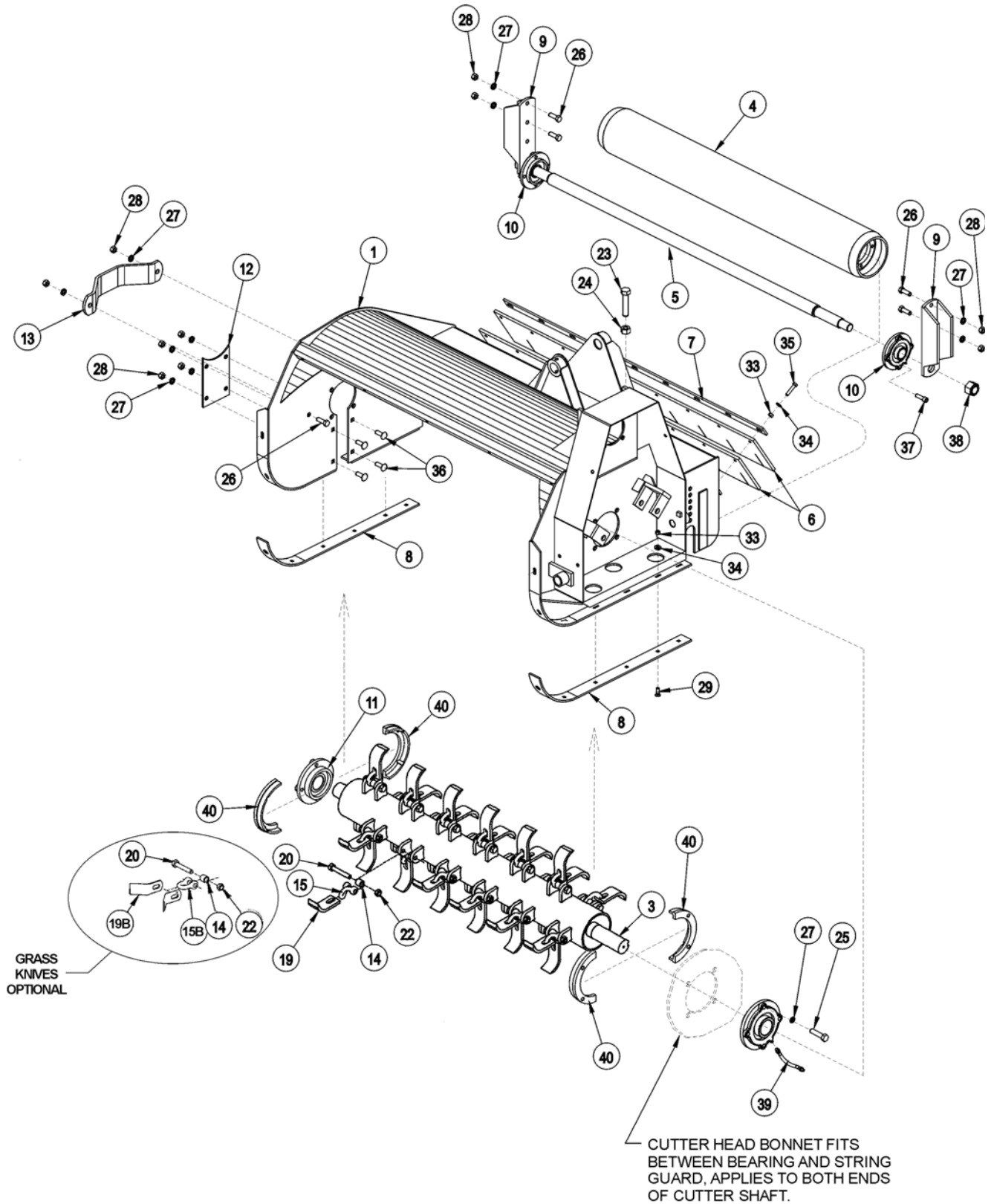

50" FLAIL MOWER ASSEMBLY

ITEM	PART NO.	QTY.	DESCRIPTION
-	06742078	AVAIL	FLAIL, BOOM,50,CPLT ASSY
1	06320170	1	CUTTER HEAD BONNET
3	34783	AVAIL	TBF50,BRUSH,KNIFE ASSY
3A	34784	AVAIL	TBF50,GRASS,KNIFE ASSY
4	TF3405	1	GROUND ROLLER
5	TF3406	1	GROUND ROLLER TIE ROD
6	TB1006A	2	DEFLECTOR FLAP
7	TB1008	1	FLAP RETAINING BAR
8	TF3001	2	SKID SHOE
9	TF3407	2	GROUND ROLLER ADJUSTMENT BRACKET
10	TF1022	2	FLANGE BEARING 1 3/8"
11	TF1018	2	FLANGE BEARING 2 3/16"
12	TF3007A	1	COVER PLATE
13	TF1040	1	CUTTER SHAFT GUARD
14	41725.01	24	BUSHING,1ODX5/8ID
15	34782	24	CLEVIS,BRUSH
15B	34781	24	CLEVIS,GRASS
19	34780	24	BRUSH KNIFE STANDARD
19B	33714	48	HD KNIFE - OPTIONAL
20	34786	24	CAPSCREW 9/16" X 3 1/2"
22	6T2419	24	HEX NUT 9/16"
23	21838	1	CAPSCREW 3/4" X 3 1/2"
24	21825	1	HEX NUT 5/8"
25	06530218	8	CAPSCREW 1/2" X 1 3/4"
26	21731	6	CAPSCREW 1/2" X 1 1/2"
27	21990	18	LOCKWASHER 1/2"
28	21725	10	HEX NUT 1/2"
29	6T2270	12	PLOWBOLT 3/8" X 1"
31	21630	4	CAPSCREW 3/8" X 1"
32	21988	3	LOCKWASHER 3/8"
33	21625	19	HEX NUT 3/8"
34	22016	26	FLATWASHER 3/8"
35	21633	9	CAPSCREW 3/8" X 1 3/4"
36	6T7031D	4	PLOW BOLT 1/2" X 1 1/2"
37	6T2330	8	CAPSCREW 7/16" X 1 1/2" SOCKET HEAD
38	6T1023R	2	NYLOCK NUT 1 1/8" NF
39	TF1032	1	FLANGE BEARING GREASE HOSE
40	31204	2 SETS	STRING GUARD SET (2 PIECES PER SET)

50" FLAIL MOWER DRIVE ASSEMBLY

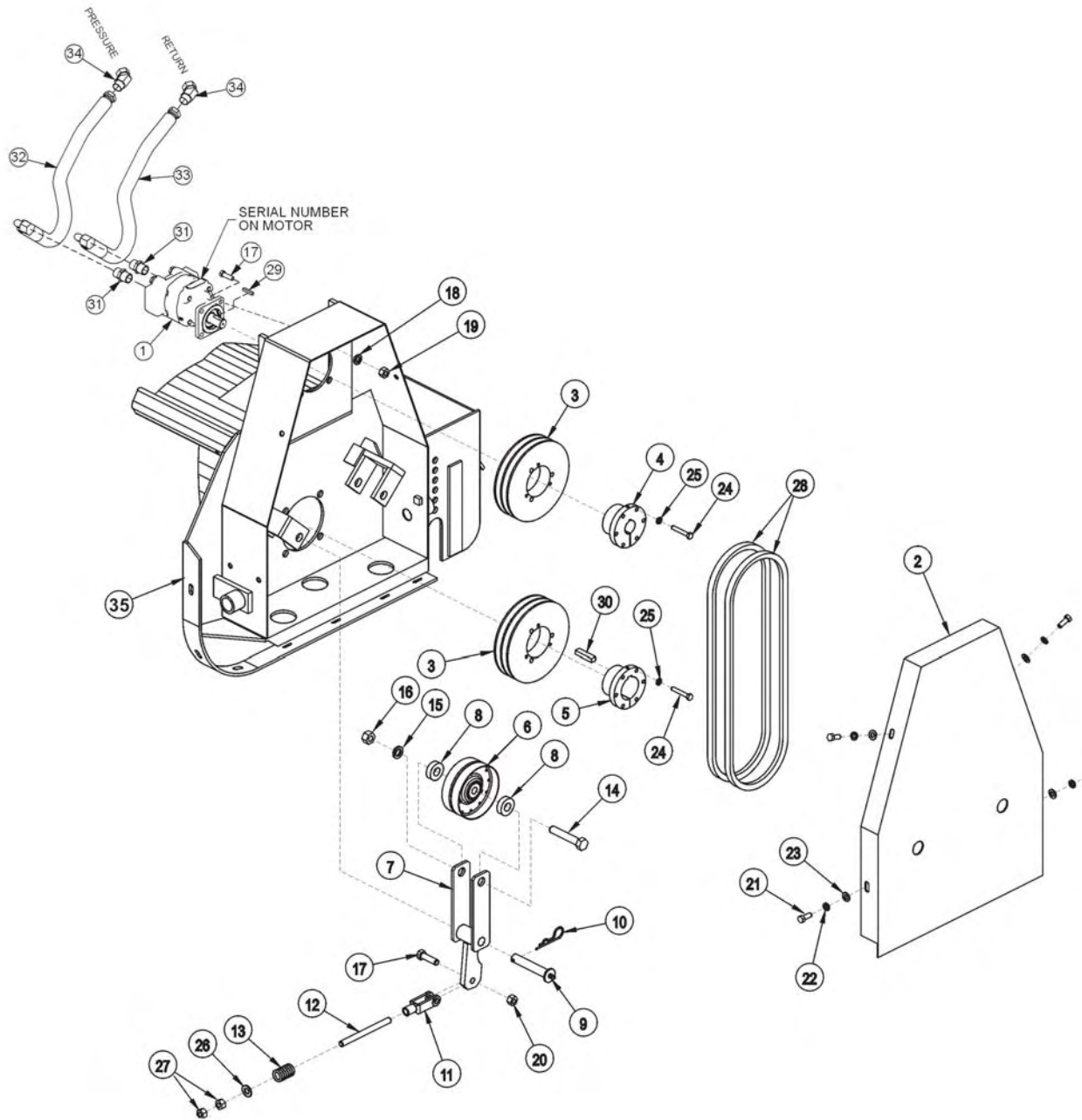

50" FLAIL MOWER DRIVE ASSEMBLY

ITEM	PART NO.	QTY.	DESCRIPTION
1	06504019	1	MOTOR
2	TF3006	1	BELT GUARD
3	TF3043	2	SHEAVE
4	TF3013	1	BUSHING
5	TF3011	1	BUSHING
6	TF3034	1	IDLER PULLEY
7	TF3205	1	IDLER ARM
8	TF3206	2	IDLER PULLEY SPACER
9	TF3605	1	IDLER ARM PIN WITH ZERK
10	6T3004	1	R - CLIP
11	PT3611A	1	CLEVIS
12	32481	1	THREADED ROD
13	TF3620	1	COMPRESSION SPRING
14	21789	1	CAPSCREW 5/8" X 3 1/2"
15	21992	1	LOCKWASHER 5/8"
16	21775	1	HEX NUT 5/8"
17	21732	5	CAPSCREW 1/2" X 1 3/4"
18	21990	4	LOCKWASHER 1/2"
19	21725	4	HEX NUT 1/2"
20	6T2418	1	LOCK NUT 1/2"
21	21630	4	CAPSCREW 3/8" X 1"
22	21988	4	LOCKWASHER 3/8"
23	22016	4	FLATWASHER 3/8"
24	21584	6	CAPSCREW 5/16" X 2"
25	21987	6	LOCKWASHER 5/16"
26	27938	1	FLATWASHER 1/2"
27	21700	2	HEX NUT 1/2" NF
28	TF3021	2	BELT
29	TF1125	1	SQUARE KEY
30	TF1025	1	SQUARE KEY MOTOR
31	33555	2	ADAPTER
32	34236	1	HOSE ,1 x 83 (PRESSURE)
33	06500485	1	HOSE,1 X 78 (RETURN)
34	24724	2	SWIVEL FITTING
35	*	REF.	CUTTER HEAD - REFER TO CUTTER HEAD ASY

50" FLAIL MOWER HYDRAULIC SHIELD ASSEMBLY

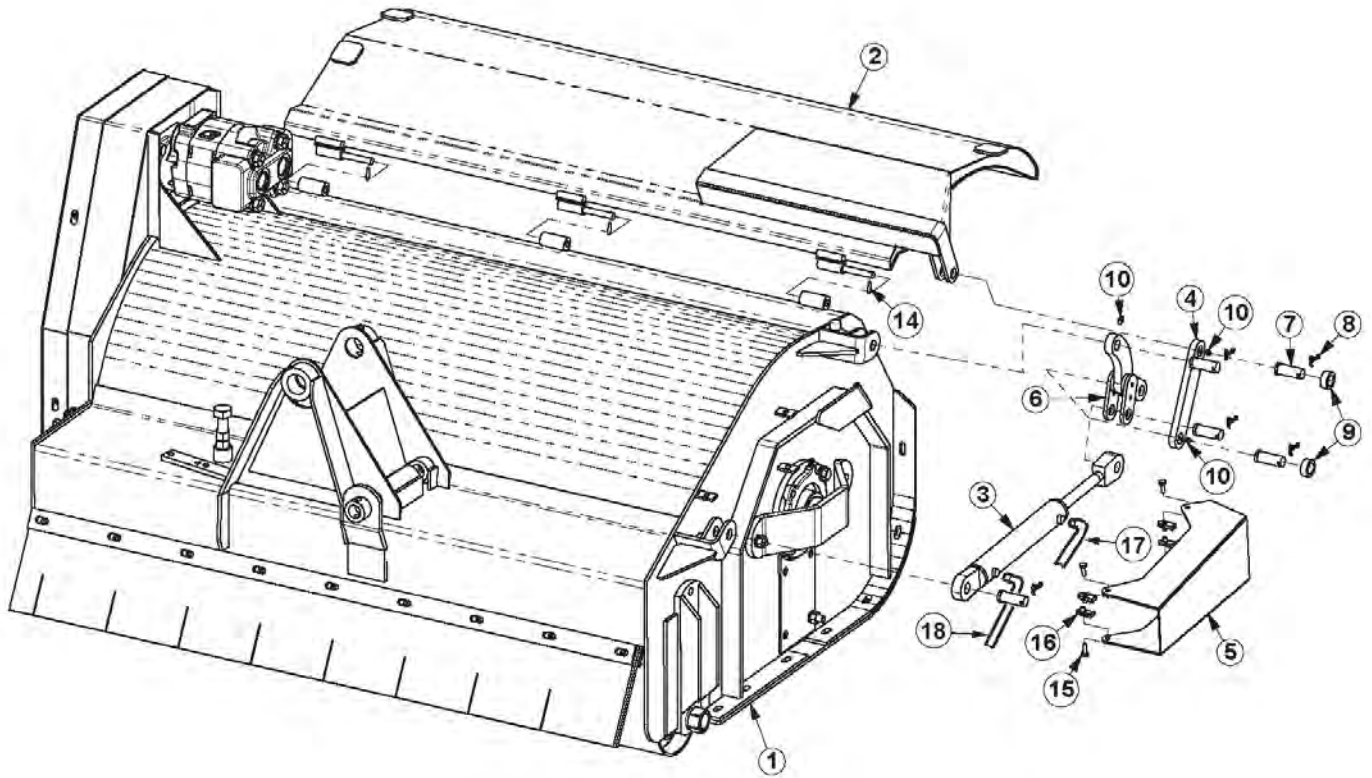

ITEM	P/N	QTY.	DESCRIPTION
1	06742078	1	TBF50,BRUSH,HS,CPLT
2	06320171	1	SHIELD,HYDRO,TBF50
3	33785	1	CYLINDER,1.5x8,.75PIN
4	06401255	1	LIMK,1,TBF50,HS
5	06370150	1	SHIELD,CYL,TBF50,HS
6	06370143	1	LINK,2,TBF50,HS
7	06537028	5	PIN,.75x1.61,SHLDR,5/32CTTR
8	22523	5	COTTER PIN,5/32x1 1/4
9	34518	2	SPACER,1 1/4x13/16x1/2
10	6T3207	3	GREASE ZERK,1/4"
11	33477	1	VIBRATION ISOLATOR,5/16 NC
12	06420036	1	ROD,THREADED,1/4 x 1 1/4 NC
13	21525	2	HEX NUT, 1/4" NC
14	34698	3	ROLL PIN, PLAIN, 3/16 X 7/8"
15	21529	4	CAPSCREW,1/4" X 3/4" NC
16	35176	4	U-NUT,1/4,3/4 TO CENTER
17	06500487	1	HOSE,1/4 x 117
18	06500486	1	HOSE,1/4 x 107

BOOM FLAIL PIVOT / HEAD ASSEMBLY

ITEM	PART NO.	QTY.	DESCRIPTION
1	TF3015	1	PIVOT ASY
2	TB1028	1	PIVOT ARM WITH BUSHINGS AND ZERKS
3	6T3003D	1	PIN CLEVIS
4	TB1023	2	ROLL PIN
5	TF3097	1	PIN
6	TF3090	1	PIN
7	TB1024	1	PIN
8	TB1027	1	PIN
9	31688	1	CAPSCREW 7/16" X 3 1/4"
10	21989	1	LOCKWASHER 7/16"
11	21675	1	HEX NUT 7/16"
12	21635	4	CAPSCREW 3/8" X 2 1/4"
13	21988	3	LOCKWASHER 3/8"
14	21625	4	HEX NUT 3/8"
15	TB1030	3	BUSHING
16	TB3031	1	DOUBLE HOSE
16	31723	1	CLAMP KIT, TBF 50
**	21679	4	CAPSCREW, 7/16" x 1" NC
**	31916	4	POST
**	31917	4	CUSHION
**	31955	1	PLATE

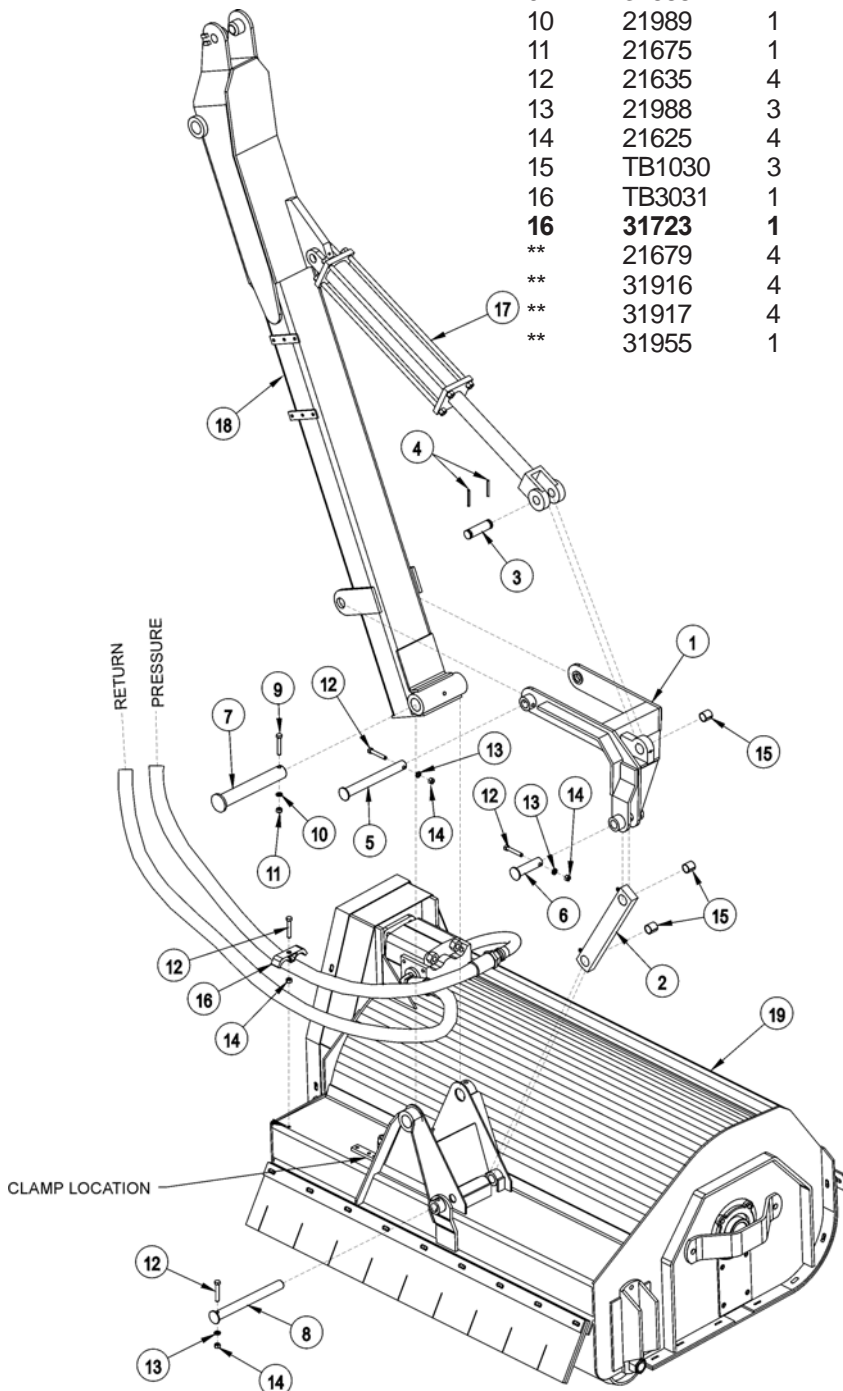

3" X 10" WELDED CYLINDER

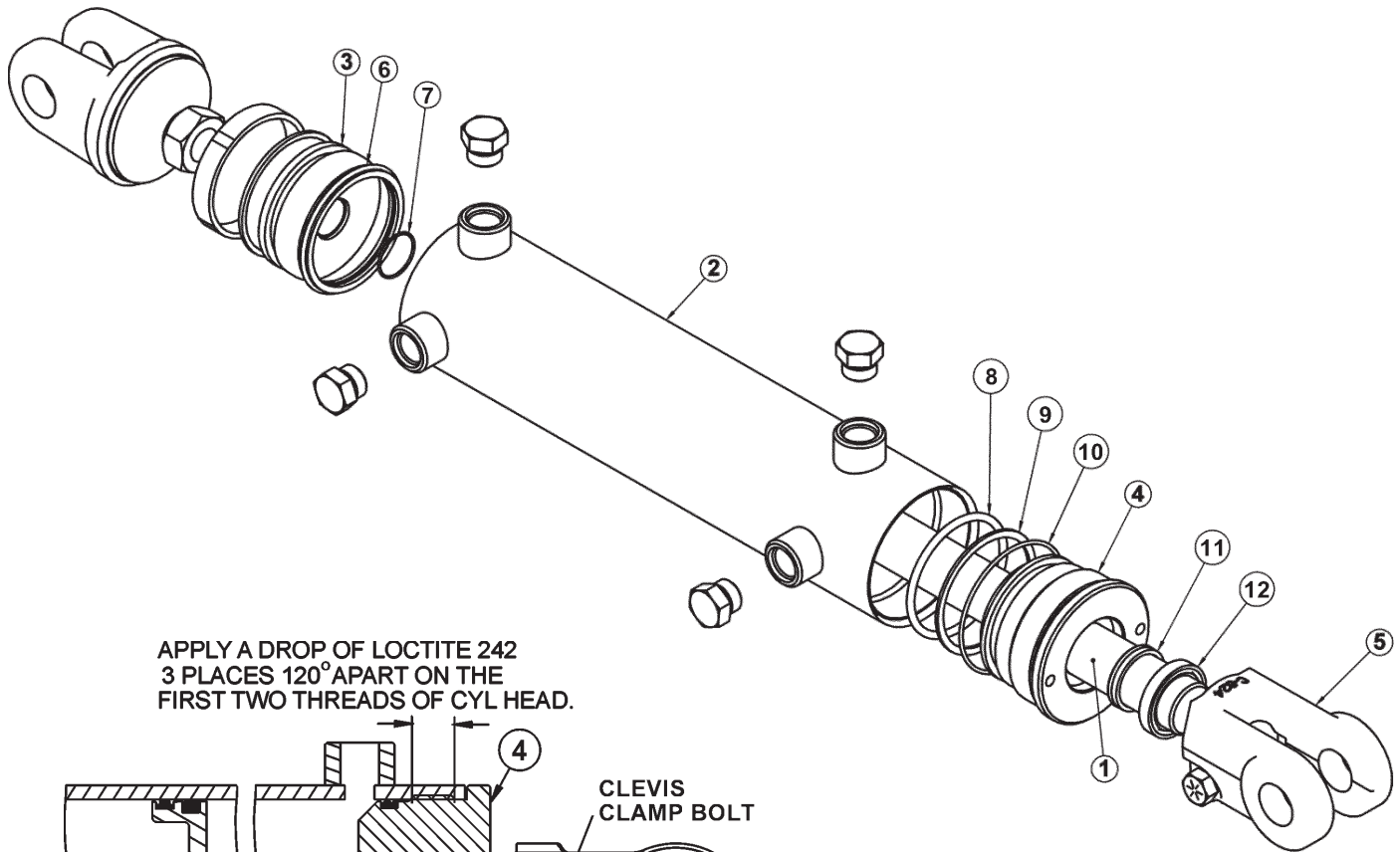

APPLY A DROP OF LOCTITE 242
3 PLACES 120° APART ON THE
FIRST TWO THREADS OF CYL HEAD.

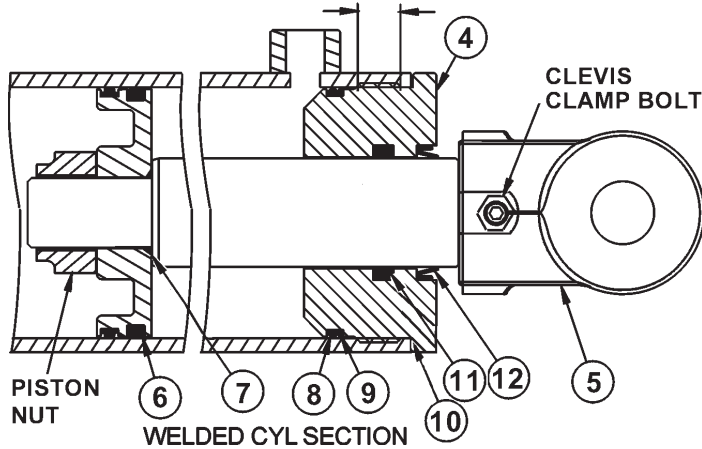

PISTON NUT

06501572

TORQUE

210 ± 5 FT. LB

CLEVIS CLAMP BOLT

3/8-16 UNC

TORQUE

26 - 30 FT. LB

WARNING - MECHANICAL FASTENERS MUST BE TORQUED TO RECOMMENDED SPECIFICATIONS DURING REPAIR TO PREVENT PERSONAL INJURY OR EQUIPMENT DAMAGE.

ITEM	PART NO.	QTY.	DESCRIPTION
*	06501021	AVAIL	HYDRAULIC CYLINDER COMPLETE
1	06501550	1	ROD
2	06501551	1	TUBE WELDMENT
3	06501552	1	PISTON
4	06501553	1	CYLINDER HEAD
5	06501554	1	CLEVIS
	06501555	AVAIL	SEAL REPAIR KIT (ITEM 6 THROUGH ITEM 12)

NOTE - ALL SEALS AND WEAR RINGS MUST BE PURCHASED IN COMPLETE SEAL REPAIR KIT.

3" X 17-1/2" WELDED CYLINDER

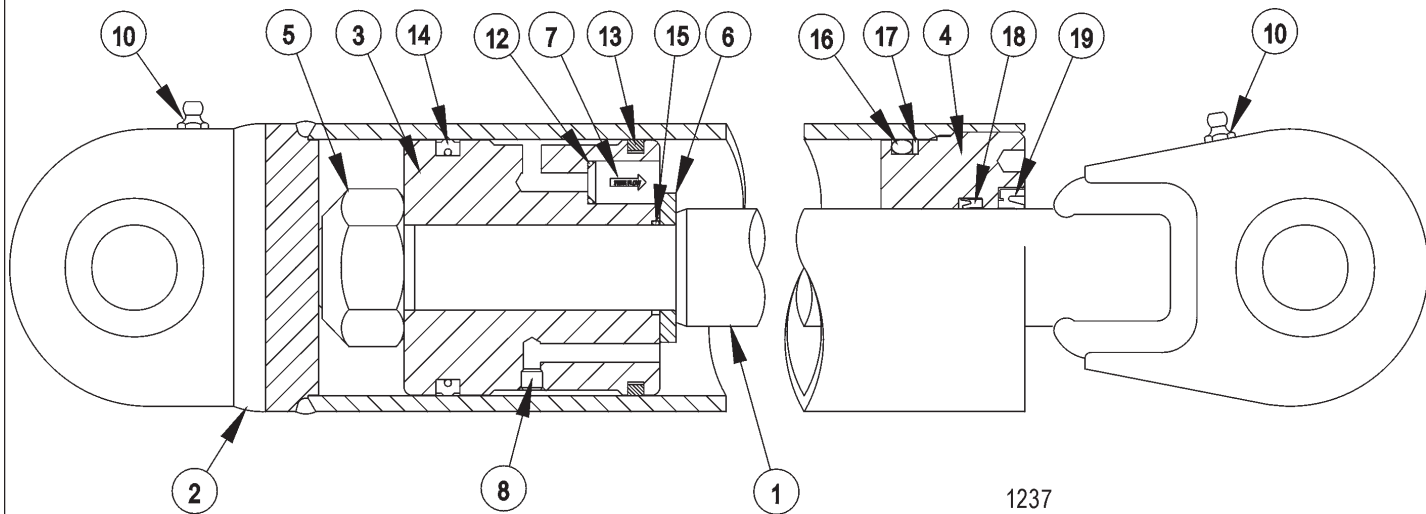

PISTON NUT

NUT 3/4-16 UNF. LOCKNUT
 NUT 1-14 UNS. LOCKNUT
 NUT 1-1/8-12 UNF. LOCKNUT
 NUT 1-1/4-12 UNF. LOCKNUT
 NUT 1-1/2-12 UNF. LOCKNUT
 NUT 1-3/4-12 UNF. LOCKNUT

TORQUE

130 FT. LB
 315 FT. LB
 350 FT. LB
 510 FT. LB
 750 FT. LB
 1800-2000 FT. LB

WARNING - MECHANICAL FASTENERS MUST BE TORQUED TO RECOMMENDED SPECIFICATIONS DURING REPAIR TO PREVENT PERSONAL INJURY OR EQUIPMENT DAMAGE.

3" X 17 1/2" CYLINDER #33705

ITEM	PART NO.	QTY.	DESCRIPTION
1	34571	1	PISTON ROD ASY
2	34572	1	BUTT & TUBE ASY
3	34573	1	PISTON
4	34574	1	GLAND
5	34575	1	LOCK NUT, 1"-14
6	34576	1	SPACER
7	34577	1	CHECK VALVE, KEPNER
8	34578	1	ORIFICE
9	33761	1	SEAL KIT, PACKING (INCLUDES ITEMS 12 THRU 19)
10		2	GREASE ZERK
12		1	O - RING
13		1	CAST IRON PISTON RING
14		1	CROWN SEAL
15		1	O - RING
16		1	O - RING
17		1	BACK - UP WASHER
18		1	U - CUP
19		1	WIPER
20	34334	AVAIL	SPHERICAL BEARING (NOT SHOWN)

3" X 18" WELDED CYLINDER

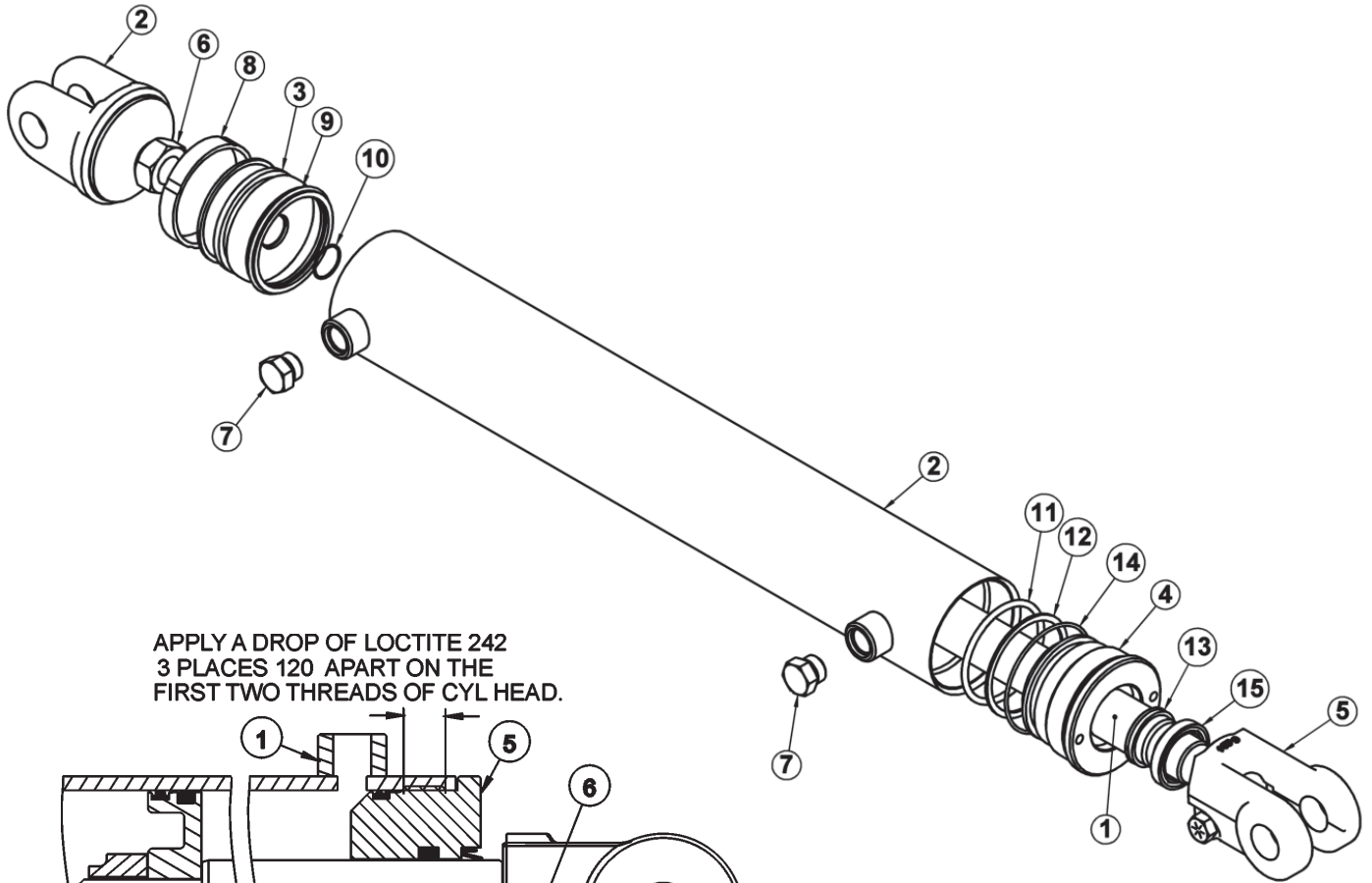

APPLY A DROP OF LOCTITE 242
3 PLACES 120 APART ON THE
FIRST TWO THREADS OF CYL HEAD.

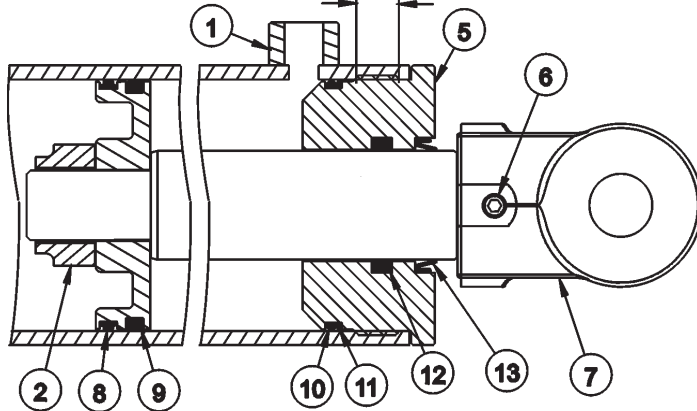

WELDED CYL SECTION

PISTON NUT

NUT 3/4-16 UNF LOCKNUT	130 FT. LB
NUT 1-14 UNS. LOCKNUT	300 FT. LB
NUT 1 1/8-12 UNF. LOCKNUT	350 FT. LB
NUT 1 1/4-12 UNF. LOCKNUT	525 FT. LB
NUT 1 1/2-12 UNF. LOCKNUT	750 FT. LB

TORQUE

ROD CLEVIS SET SCREW

3/8-16 UNC	20 FT. LB
------------	-----------

TORQUE

WARNING - MECHANICAL FASTENERS MUST BE TORQUED TO RECOMMENDED SPECIFICATIONS DURING REPAIR TO PREVENT PERSONAL INJURY OR EQUIPMENT DAMAGE.

ITEM	PART NO.	QTY.	DESCRIPTION
*	06501023	AVAIL	HYDRAULIC CYLINDER COMPLETE
1	06501561	1	ROD
2	06501562	1	TUBE WELDMENT
3	06501552	1	PISTON
4	06501563	1	CYLINDER HEAD
5	06501555	1	CLEVIS
	06501564	AVAIL	SEAL REPAIR KIT (INCLUDES ITEMS WITH "**")

NOTE - ALL SEALS AND WEAR RINGS MUST BE PURCHASED IN COMPLETE SEAL REPAIR KIT.

4" X 20" WELDED CYLINDER

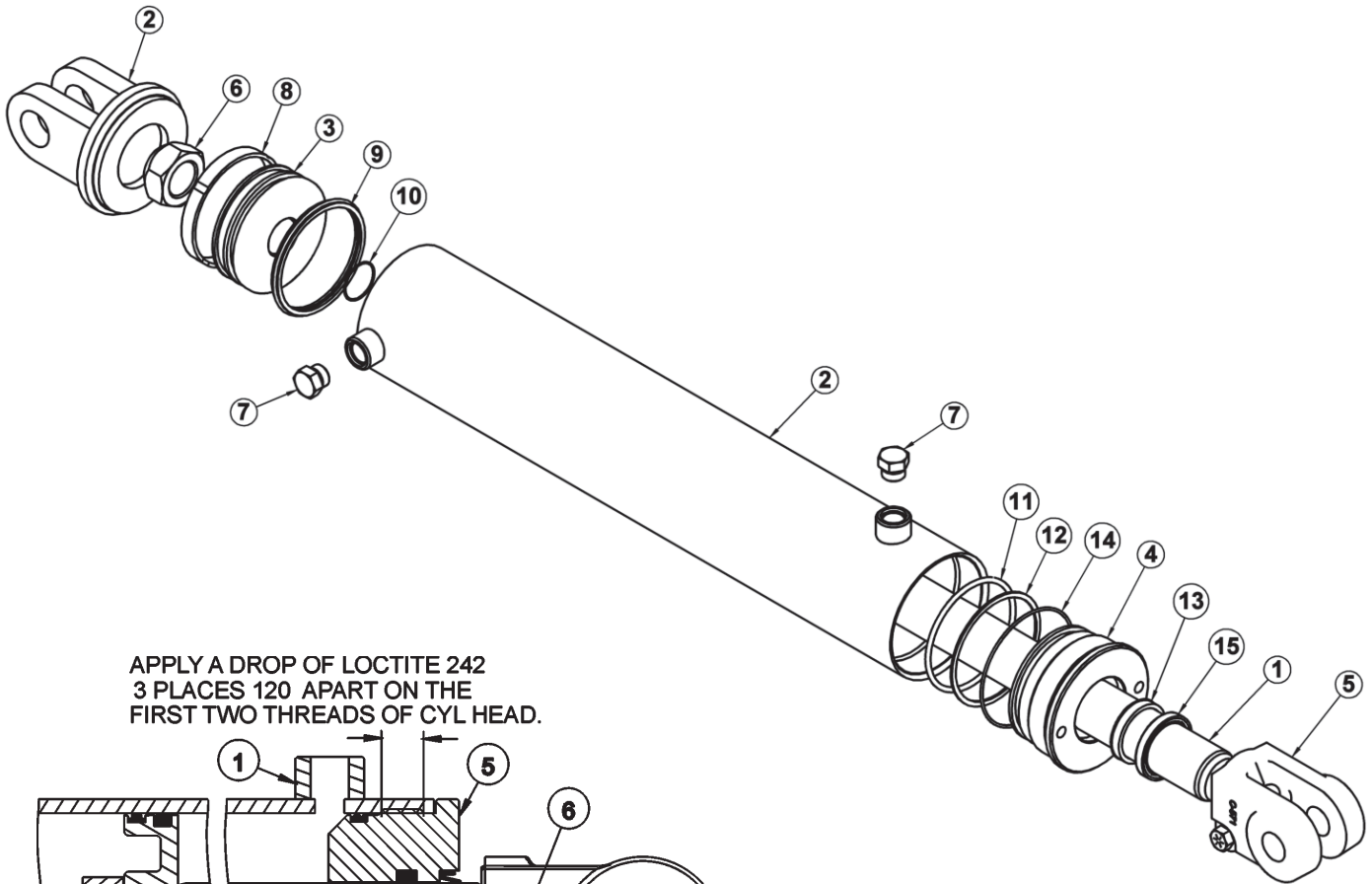

APPLY A DROP OF LOCTITE 242
3 PLACES 120 APART ON THE
FIRST TWO THREADS OF CYL HEAD.

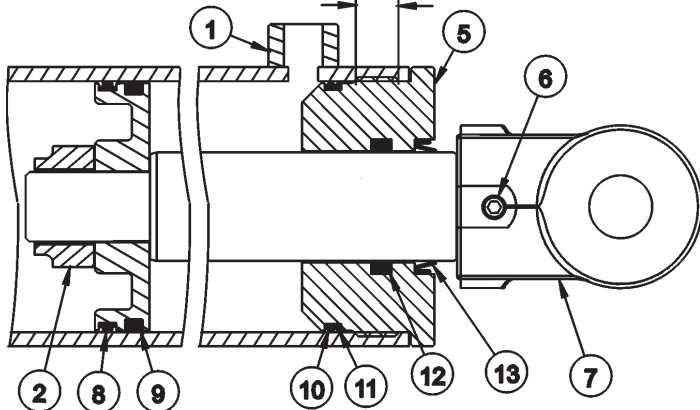

WELDED CYL SECTION

PISTON NUT

NUT 3/4-16 UNF LOCKNUT	130 FT. LB
NUT 1-14 UNS. LOCKNUT	300 FT. LB
NUT 1 1/8-12 UNF. LOCKNUT	350 FT. LB
NUT 1 1/4-12 UNF. LOCKNUT	525 FT. LB
NUT 1 1/2-12 UNF. LOCKNUT	750 FT. LB

TORQUE

ROD CLEVIS SET SCREW

3/8-16 UNC	20 FT. LB
------------	-----------

TORQUE

WARNING - MECHANICAL FASTENERS MUST BE TORQUED TO RECOMMENDED SPECIFICATIONS DURING REPAIR TO PREVENT PERSONAL INJURY OR EQUIPMENT DAMAGE.

ITEM	PART NO.	QTY.	DESCRIPTION
*	06501022	AVAIL	HYDRAULIC CYLINDER COMPLETE
1	06501556	1	ROD
2	06501557	1	TUBE WELDMENT
3	06501558	1	PISTON
4	06501559	1	CYLINDER HEAD
5	6T0172	1	CLEVIS
	06501560	AVAIL	SEAL REPAIR KIT

NOTE - ALL SEALS AND WEAR RINGS MUST BE PURCHASED IN COMPLETE SEAL REPAIR KIT.

5" X 20" WELDED CYLINDER

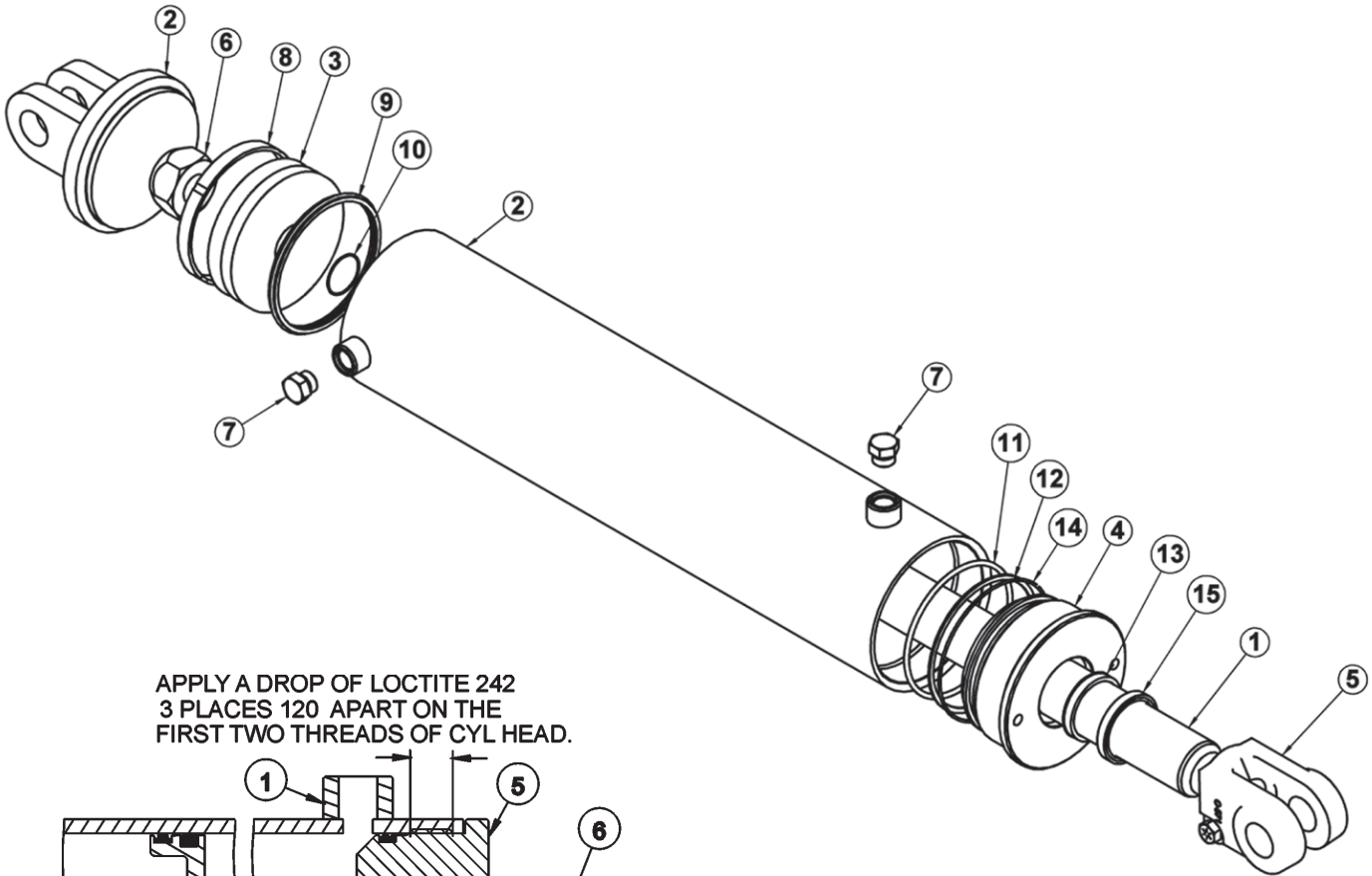

APPLY A DROP OF LOCTITE 242
3 PLACES 120 APART ON THE
FIRST TWO THREADS OF CYL HEAD.

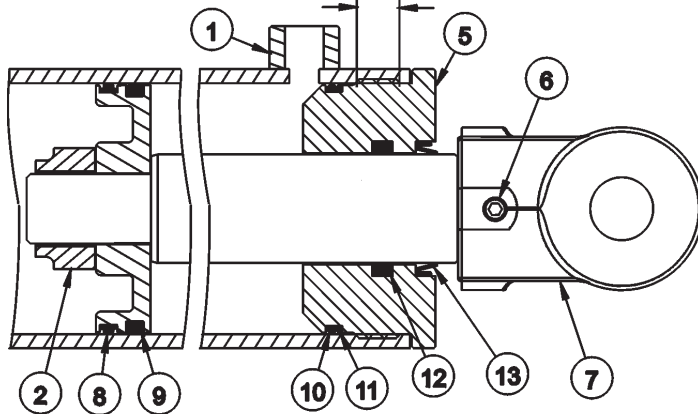

WELDED CYL SECTION

PISTON NUT

	<u>TORQUE</u>
NUT 3/4-16 UNF LOCKNUT	130 FT. LB
NUT 1-14 UNS. LOCKNUT	300 FT. LB
NUT 1 1/8-12 UNF. LOCKNUT	350 FT. LB
NUT 1 1/4-12 UNF. LOCKNUT	525 FT. LB
NUT 1 1/2-12 UNF. LOCKNUT	750 FT. LB

ROD CLEVIS SET SCREW

	<u>TORQUE</u>
3/8-16 UNC	20 FT. LB

WARNING - MECHANICAL FASTENERS MUST BE TORQUED TO RECOMMENDED SPECIFICATIONS DURING REPAIR TO PREVENT PERSONAL INJURY OR EQUIPMENT DAMAGE.

ITEM	PART NO.	QTY.	DESCRIPTION
*	06501020	AVAIL	HYDRAULIC CYLINDER COMPLETE
1	06501544	1	ROD
2	06501545	1	TUBE WELDMENT
3	06501546	1	PISTON
4	06501547	1	CYLINDER HEAD
5	06501548	1	CLEVIS
	06501549	AVAIL	SEAL REPAIR KIT

NOTE - ALL SEALS AND WEAR RINGS MUST BE PURCHASED IN COMPLETE SEAL REPAIR KIT.

ROTARY MOWER SPINDLE ASSEMBLY

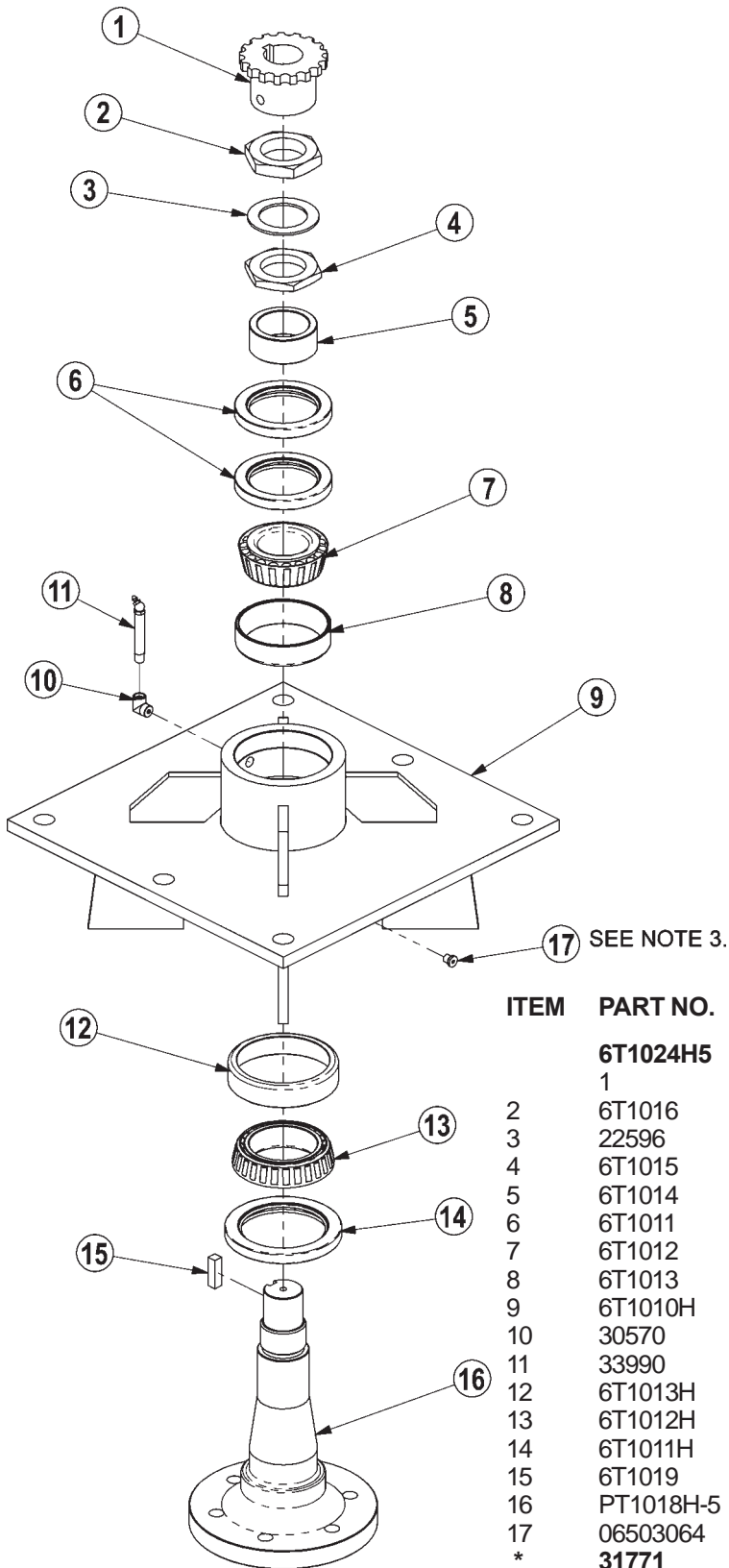

ITEM	PART NO.	QTY.	DESCRIPTION
	6T1024H5	AVAIL	SPINDLE ASSEMBLY COMPLETE
	1	6T1031	1 SPROCKET
2	6T1016	1	BEARING LOCK NUT - THICK
3	22596	1	JAM WASHER
4	6T1015	1	BEARING ADJUSTMENT NUT - THIN
5	6T1014	1	BEARING ADJUSTMENT SLEEVE
6	6T1011	1	UPPER SEAL - SET OF 2
7	6T1012	1	BEARING CONE
8	6T1013	1	BEARING CUP
9	6T1010H	1	SPINDLE HOUSING
10	30570	1	FITTING STREET ELBOW
11	33990	1	GREASE ZERK
12	6T1013H	1	BEARING CUP
13	6T1012H	1	BEARING CONE
14	6T1011H	1	LOWER SEAL
15	6T1019	1	SPINDLE KEY
16	PT1018H-5	1	SPINDLE
17	06503064	1	O-RING PLUG, 1/8"
*	31771	AVAIL	SPINDLE REBUILD KIT (INCLUDE ITEMS 2 THRU 8 AND 12 THRU 15)

NOTES:

1. FREEPLAY: .001" - .003"
2. GREASE: FILL WITH MOBILITH SHC 220.
3. APPLY LOCTITE "271" TO O-RING PLUG THRS.

5 SP HUSCO - LOAD SENSE (06502103)

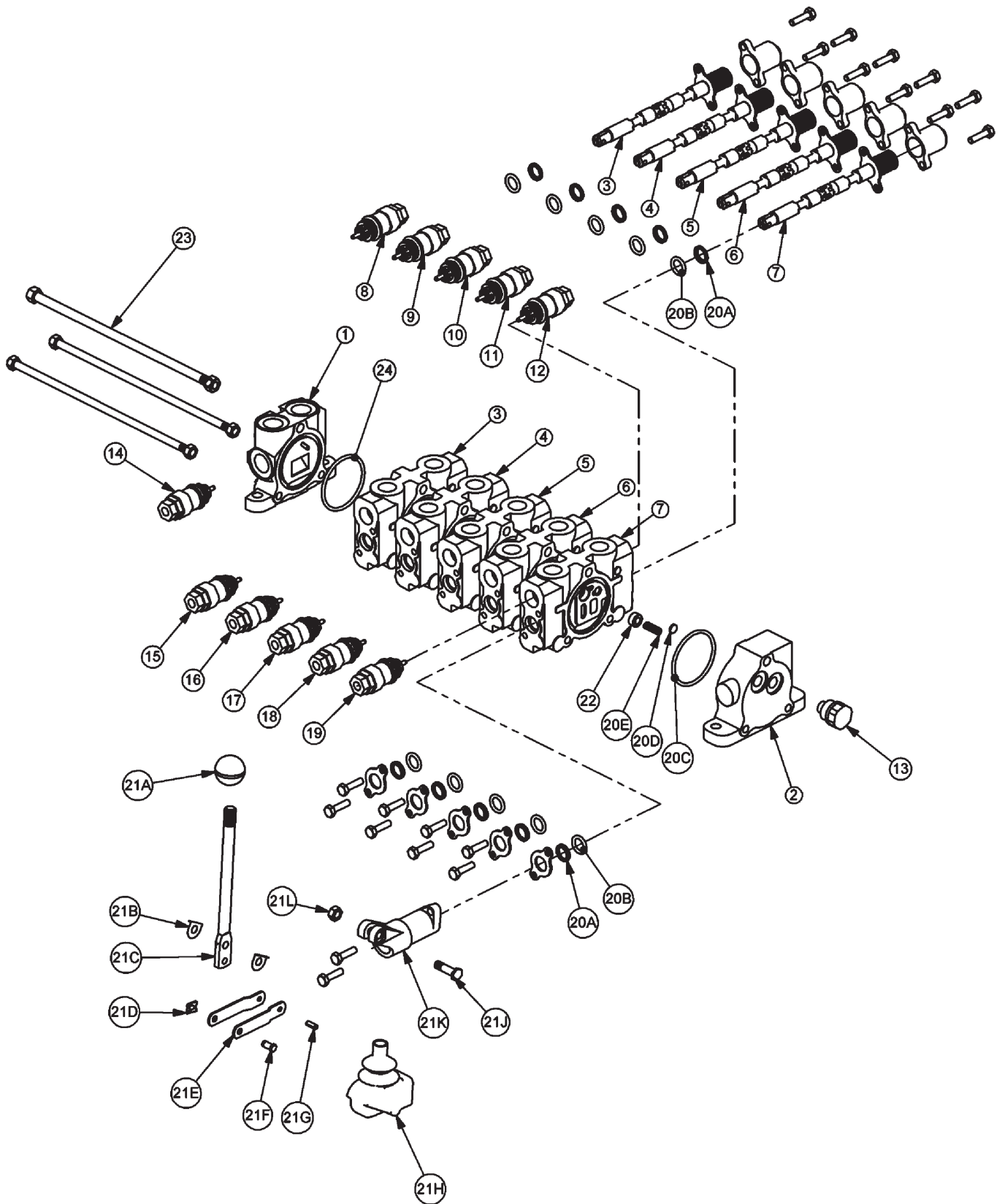

5 SP HUSCO - LOAD SENSE (06502103)

ITEM	PART NO.	QTY	DESCRIPTION
1	31595	1	INLET END COVER
2	31594	1	END COVER, LOAD SENSE
3	31597	1	VALVE SECTION (DOUBLE ACTING, CENTER SPRING)
4	31597	1	VALVE SECTION (DOUBLE ACTING, CENTER SPRING)
5	31597	1	VALVE SECTION (DOUBLE ACTING, CENTER SPRING)
6	31598	1	VALVE SECTION (DOUBLE ACTING, CENTER SPRING, METERED)
7	31597	1	VALVE SECTION (DOUBLE ACTING, CENTER SPRING) (REMOVE SHUTTLE DISC)
8	06503067	1	RELIEF PLUG
9	TB1017K	1	RELIEF VALVE, 2500 PSI
10	TB1017J	1	RELIEF VALVE, 2175 PSI
11	TB1017H	1	RELIEF VALVE, 1750 PSI
12	22588	1	RELIEF VALVE, 500 PSI
13	06503068	1	RELIEF PLUG
14	6T4209	1	RELIEF PLUG
15	06502003	1	RELIEF VALVE, 2500 PSI
16	TB1017F	1	RELIEF VALVE, 1750 PSI
17	TB1017F	1	RELIEF VALVE, 1750 PSI
18	TB1017H	1	RELIEF VALVE, 1750 PSI
19	22588	1	RELIEF VALVE, 500 PSI
20	31593	5	VALVE SEAL KIT (FOR ONE SECTION)
20A		2	WIPER
20B		2	O-RING SMALL
20C		1	O-RING LARGE
20D		1	SHUTTLE DISC
20E		1	SPRING
21	TB1017L	5	LEVER KIT (FOR ONE SECTION)
21A		1	LEVER KNOB
21B		1	LEVER
21C		2	LEVER WASHER
21D		1	LEVER CLIP
21E		2	LINKAGE
21F		1	LEVER PIN
21G		1	ROLL PIN
21H		1	LEVER BOOT
21J		1	LEVER BOLT
21K		1	LEVER DUST COVER
21L		1	LEVER NUT
22	31603	5	COMPENSATOR
23	TB1017V	1	TIE ROD KIT
24	24214	1	O-RING, LARGE

5 SP HUSCO - LOAD SENSE (06502115)

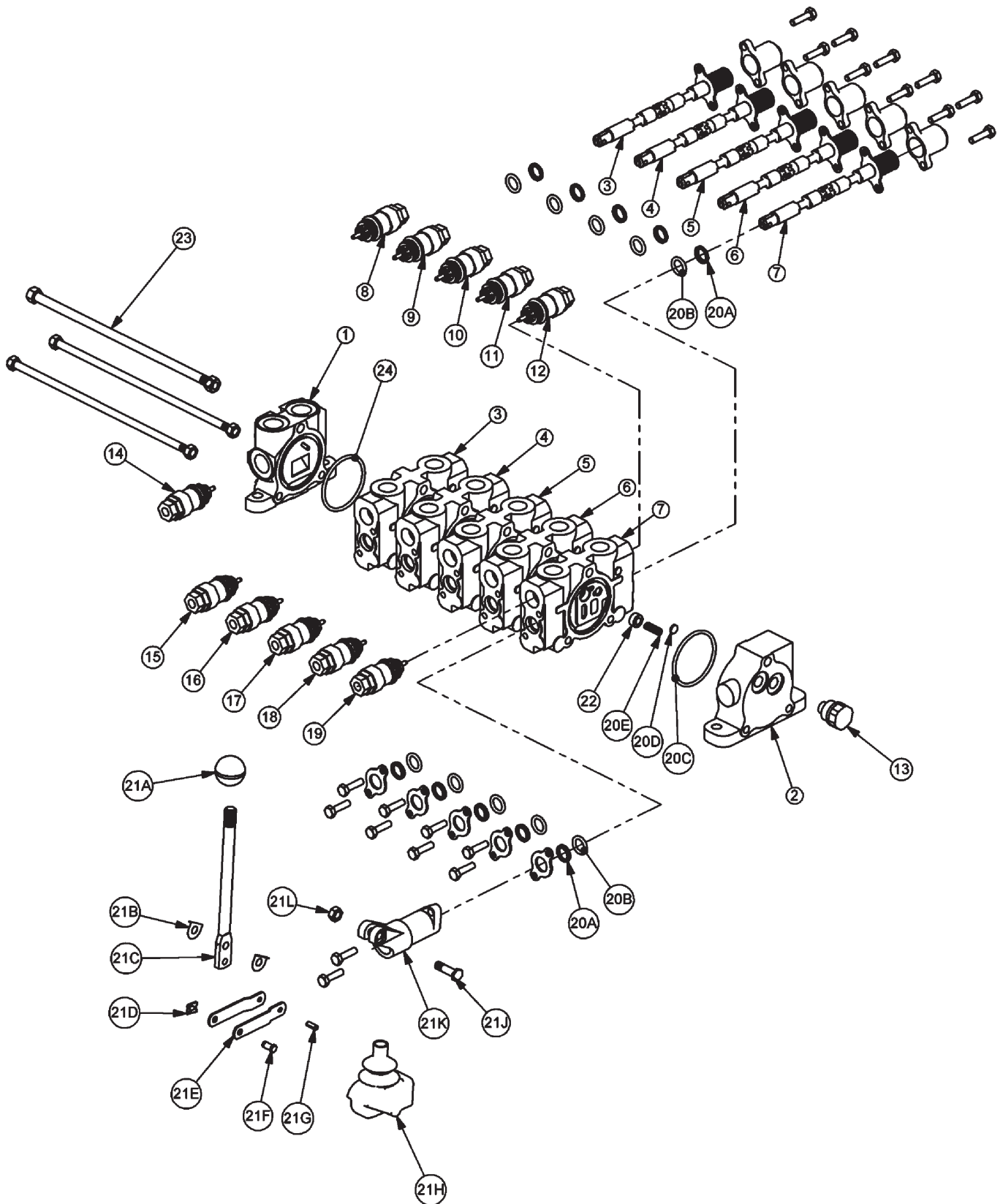

5 SP HUSCO - LOAD SENSE (06502115)

ITEM	PART NO.	QTY	DESCRIPTION
1	31595	1	INLET END COVER
2	31594	1	END COVER, LOAD SENSE
3	31597	1	VALVE SECTION (DOUBLE ACTING, CENTER SPRING)
4	31597	1	VALVE SECTION (DOUBLE ACTING, CENTER SPRING)
5	31600	1	VALVE SECTION (DOUBLE ACTING, DETENT-FLOAT)
6	31598	1	VALVE SECTION (DOUBLE ACTING, CENTER SPRING, METERED)
7	31597	1	VALVE SECTION (DOUBLE ACTING, CENTER SPRING) (REMOVE SHUTTLE DISC)
8	06503067	1	RELIEF PLUG
9	TB1017K	1	RELIEF VALVE, 2500 PSI
10	TB1017J	1	RELIEF VALVE, 2175 PSI
11	TB1017H	1	RELIEF VALVE, 1750 PSI
12	22588	1	RELIEF VALVE, 500 PSI
13	06503068	1	RELIEF PLUG
14	6T4209	1	RELIEF PLUG
15	06502003	1	RELIEF VALVE, 2500 PSI
16	TB1017F	1	RELIEF VALVE, 1750 PSI
17	TB1017F	1	RELIEF VALVE, 1750 PSI
18	TB1017H	1	RELIEF VALVE, 1750 PSI
19	22588	1	RELIEF VALVE, 500 PSI
20	31593	5	VALVE SEAL KIT (FOR ONE SECTION)
20A		2	WIPER
20B		2	O-RING SMALL
20C		1	O-RING LARGE
20D		1	SHUTTLE DISC
20E		1	SPRING
21	TB1017L	5	LEVER KIT (FOR ONE SECTION)
21A		1	LEVER KNOB
21B		1	LEVER
21C		2	LEVER WASHER
21D		1	LEVER CLIP
21E		2	LINKAGE
21F		1	LEVER PIN
21G		1	ROLL PIN
21H		1	LEVER BOOT
21J		1	LEVER BOLT
21K		1	LEVER DUST COVER
21L		1	LEVER NUT
22	31603	5	COMPENSATOR
23	TB1017V	1	TIE ROD KIT
24	24214	1	O-RING, LARGE

5 SP DANFOSS - LOAD SENSE

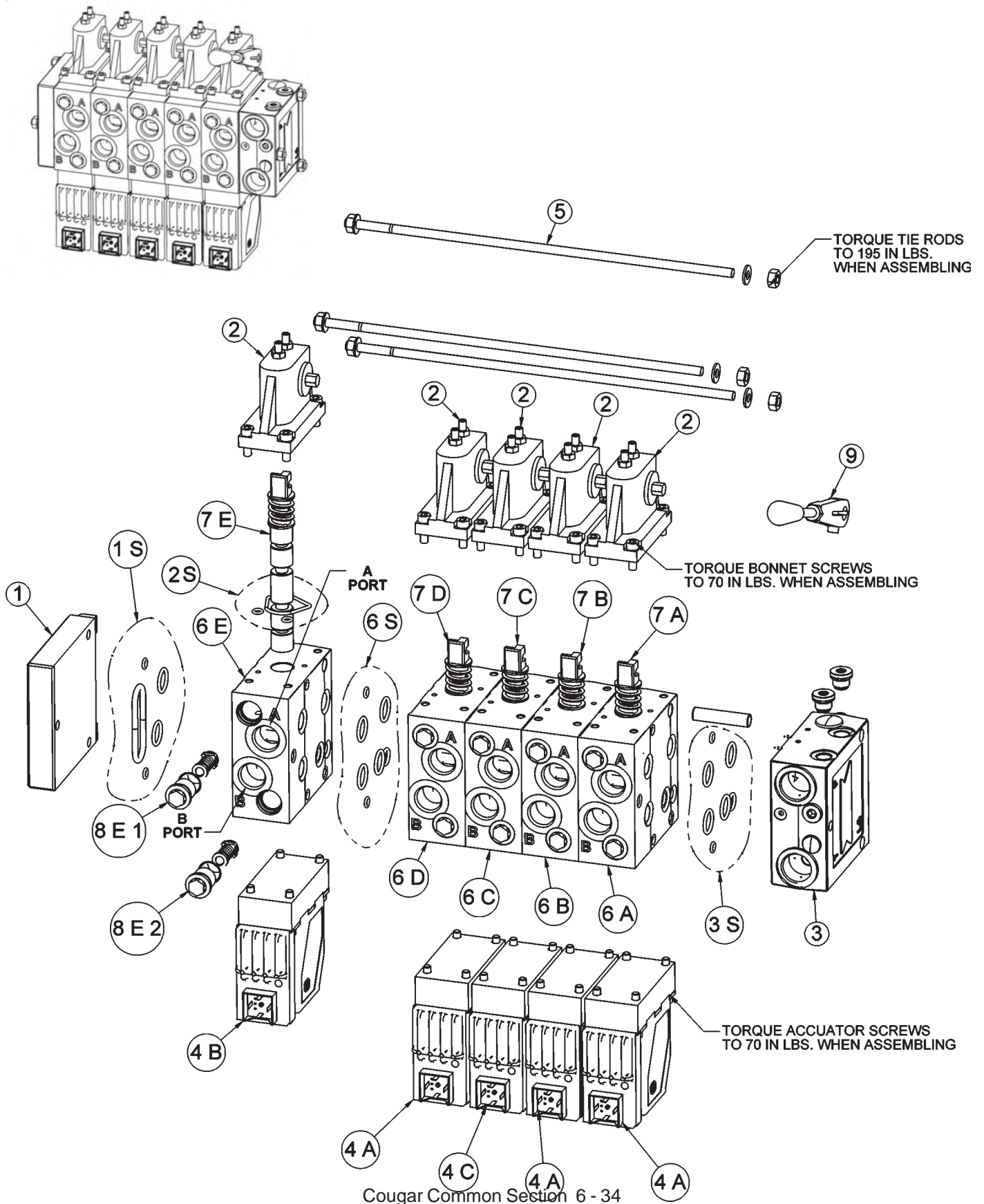

5 SP DANFOSS - LOAD SENSE

ITEM	PART NO.	QTY.	DESCRIPTION
	06502096		VLV,5SP,32PVG
1	06502074	1	END PLATE
1S	06505013	1	END PLATE SEAL KIT
2	*	5	BONNET
2S	06505042	1	BONNET SEAL KIT
2A	42197	1	MAIN BOOM BONNET
2B	42197	1	SECONDARY BOOM BONNET
2B	42197	1	DECK ROLL BONNET
2B	42197	1	BOOM SWIVEL BONNET
2B	42197	1	DECK SHIELD BONNET
3	34308	1	INLET SECTION
3S	06505013	1	INLET SECTION SEAL KIT
4	*	5	ELECTRONIC ACCUATOR
4A	06502101	1	MAIN BOOM ELECTRONIC ACCUATOR
4A	06502101	1	SECONDARY BOOM ELECTRONIC ACCUATOR
4C	06502100	1	DECK ROLL ELECTRONIC ACCUATOR
4A	06502101	1	BOOM SWIVEL ELECTRONIC ACCUATOR
4B	06502099	1	DECK SHIELD ELECTRONIC ACCUATOR
4B	42200	1	DECK SHIELD ELECTRONIC ACCUATOR
5	42202	1	TIE-BOLT KIT
6	*	5	SECTION
6S	06505013	1	SECTION SEAL KIT
6A	42698	1	MAIN BOOM SECTION
6B	42698	1	SEC BOOM SECTION
6C	06502076	1	DECK ROLL SECTION
6D	42698	1	BOOM SWIVEL SECTION
6E	06502077	1	SHIELD SECTION
7	*	5	SPOOL
7A	42697	1	MAIN BOOM SPOOL
7B	42697	1	SEC BOOM SPOOL
7C	4242106	1	DECK ROLL SPOOL
7D	06502073	1	BOOM SWIVEL SPOOL
7E	42201	1	DECK SHIELD SPOOL
8	*	10	ANTI CAV/SHOCK RELIEF
8A1	42650	1	MAIN BOOM A PORT RELIEF
8A2	06502069	1	MAIN BOOM B PORT RELIEF
8B1	42650	1	SEC BOOM A PORT RELIEF
8B2	42295	1	SEC BOOM B PORT RELIEF
8C1	42296	1	DECK ROLL A PORT RELIEF
8C2	42295	1	DECK ROLL B PORT RELIEF
8D1	42295	1	BOOM SWIVEL A PORT RELIEF
8D2	42295	1	BOOM SWIVEL B PORT RELIEF
8E1	06502069	1	DECK SHIELD A PORT RELIEF
8E2	06502069	1	DECK SHIELD B PORT RELIEF
9	33459	1	HANDLE

RESERVOIR TANK FILTER ASSEMBLY

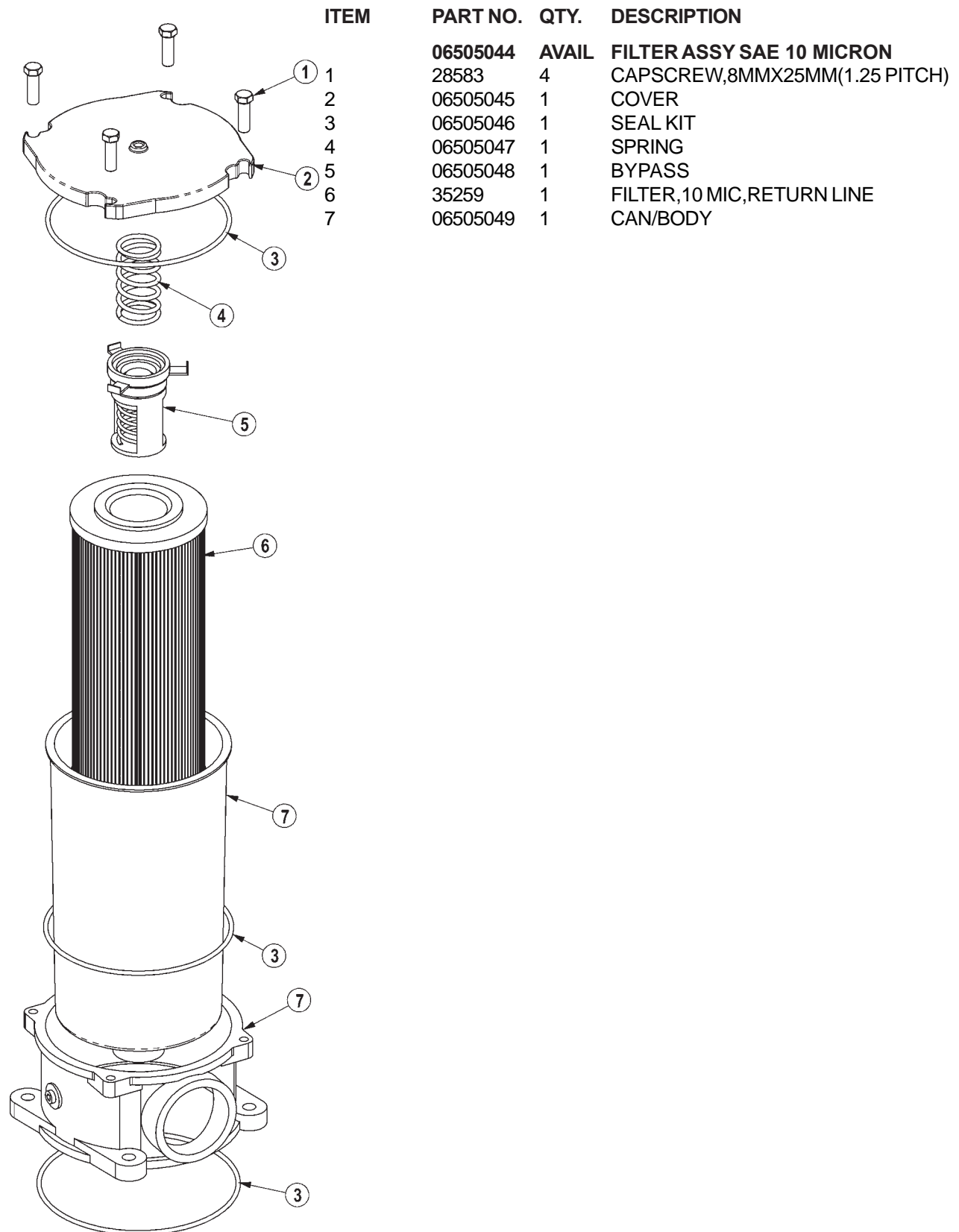

FRONT HYDRAULIC PUMP

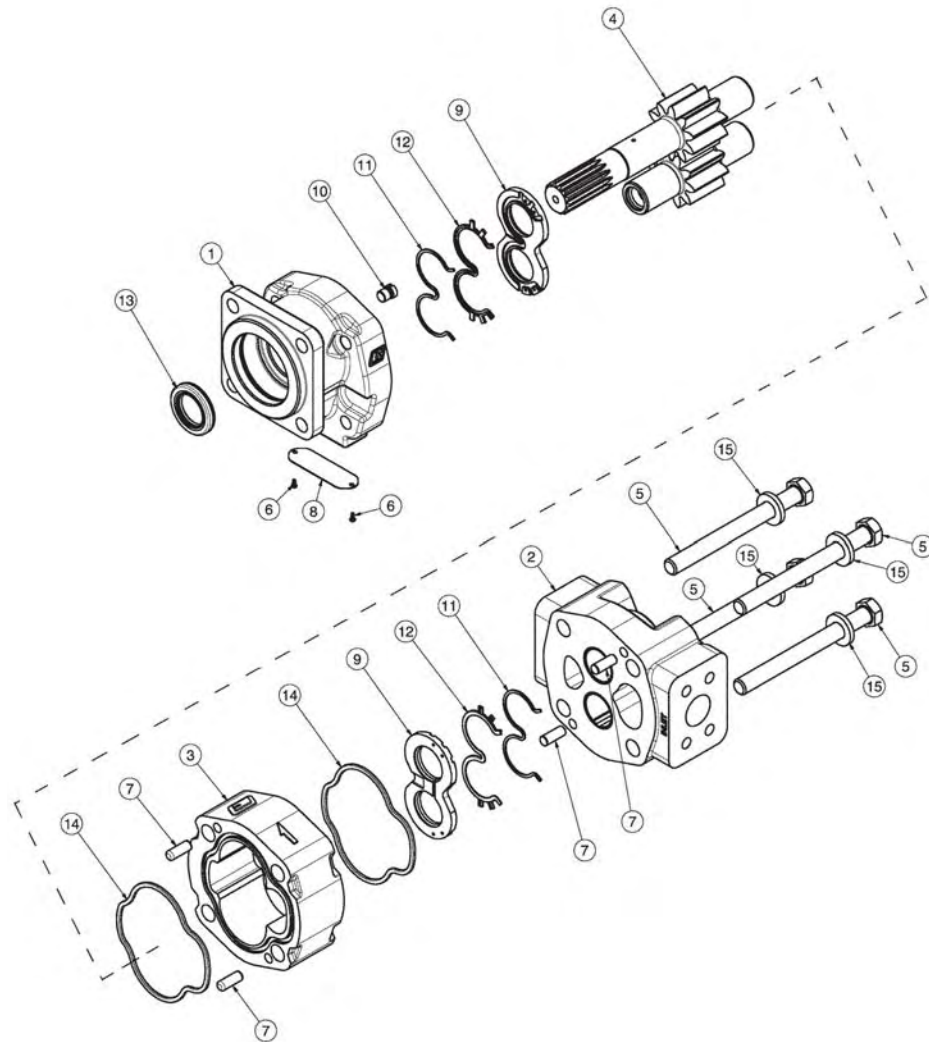

ITEM	PART NO.	QTY.	DESCRIPTION
*	23152	AVAIL	PUMP ASSEMBLY 1 3/4" COMPLETE
1	22766	1	SHAFT END COVER
2	22779	1	PORT END COVER
3	22774	1	HOUSING,GEAR
4	22771	1	SET,GEAR
5	23824	4	CAPSCREW
6	06504078	2	SCREW,DRIVE
7	22773	4	DOWEL PIN
8	06504077	1	NAME PLATE
9	22770	2	THRUST PLATE
10	06504087	1	PLUG
11	06504075	2	SEAL,BK-UP
12	06504074	2	SEAL,CHANNEL
13	22765	1	SEAL,LIP
14	06504076	2	SEAL,SQ-R
15	02961917	4	WASHER
	6T5322	AVAIL	SEAL APPLICATOR TOOL
	24150	AVAIL	SEAL KIT (INCLUDES 11, 12, 13 AND 14)

60" ROTARY MOTOR

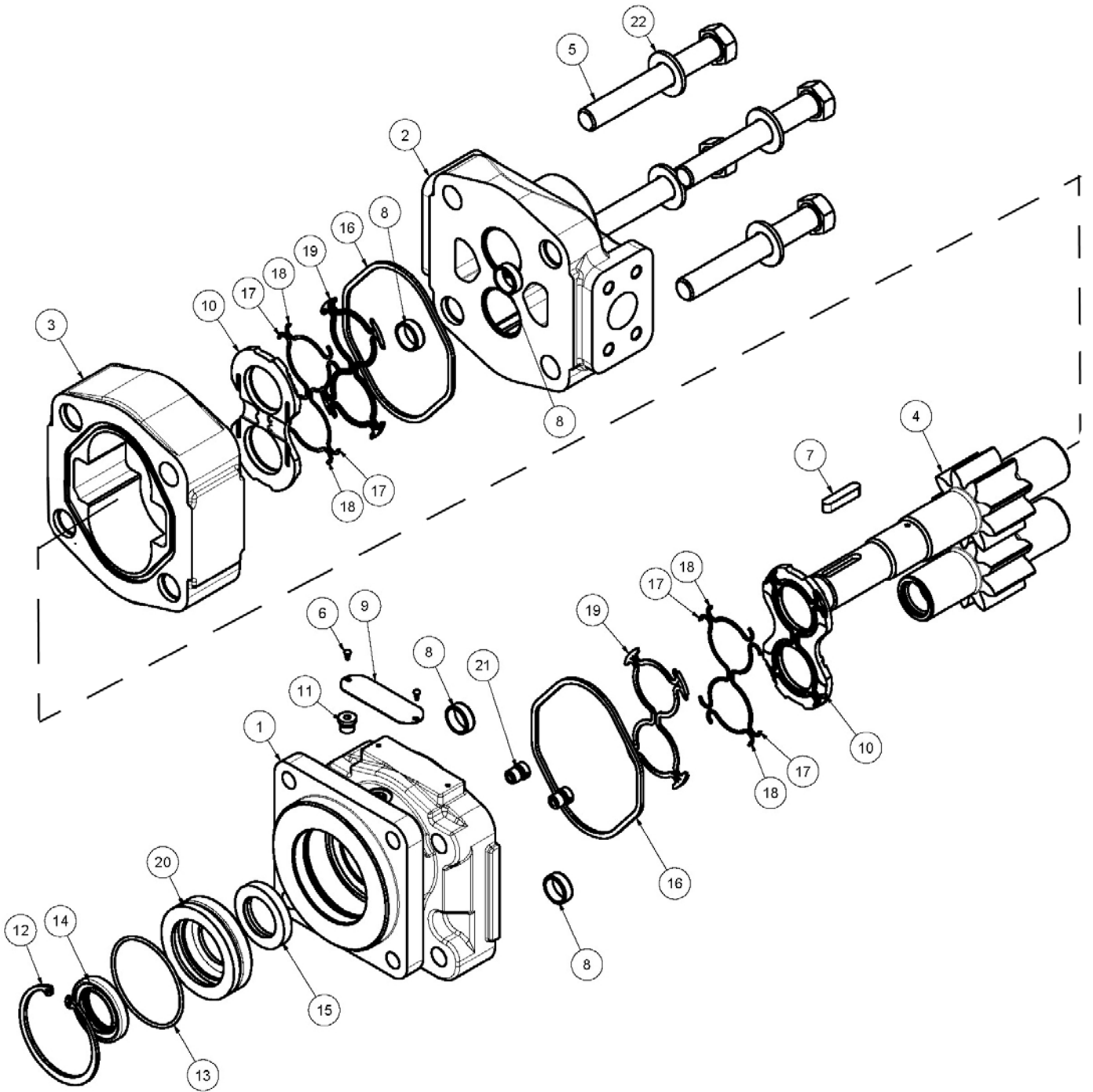

60" ROTARY MOTOR

ITEM	PART NO.	QTY.	DESCRIPTION
*	06504011	AVAIL	MOTOR ASSEMBLY 2 1/4" COMPLETE TRB60
	06504103	1	SEAL KIT
1	22790	1	HOUSING, SEC
2	06504088	1	HOUSING, PEC
3	06504062	1	HOUSING, GEAR
4	06504090	1	SET, GEAR SHAFT
5	06504104	4	CAP SCREW
6	06504078	2	SCREW, DRIVE
7	06504092	1	KEY
8	06504093	4	PIN, DOWEL
9	06504094	1	NAME PLATE
10	06504095	2	THRPL
11	02961940	1	PLUG, ODT
12	02962200	1	RING, SNAP
13	06504096	1	ORING
14	6T5101	1	SEAL, LIP
15	06504097	1	SEAL, LIP
16	22797	2	SEAL, SQ-R
17	06504098	4	SEAL, SIDE CHAN
18	06504099	4	SEAL, END CHAN
19	06504100	2	SEAL, BK-UP
20	06504101	1	RTNR, SEAL
21	6T5809	2	CHECK ASS'Y
22	06504102	4	WASHER

50" FLAIL MOTOR

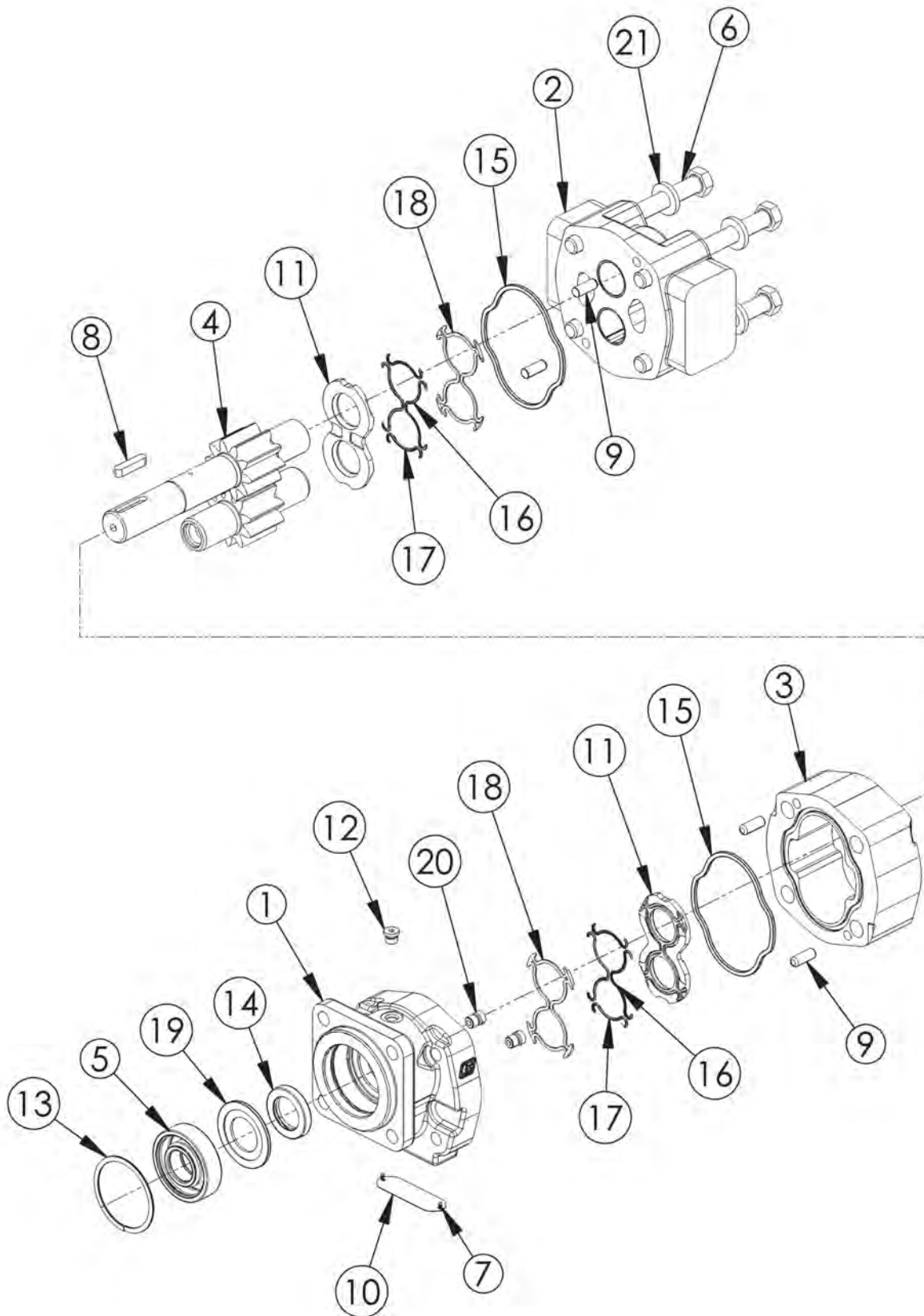

50" FLAIL MOTOR

ITEM	PART NO.	QTY.	DESCRIPTION
*	06504019	AVAIL	MOTOR ASSEMBLY TBF50
*	06504023	1	SEAL KIT (ITEMS 14,15,16,17 & 19)
1	06504039	1	SHAFT END COVER
2	06504060	1	PORT END COVER
3	06504041	1	HOUSING, GEAR
4	06504042	1	SET, GEAR SHAFT
5	TF4402	1	BALL BEARING
6	06504043	4	CAPSCREW
7	06504044	2	SCREW, DRIVE
8	06504028	1	KEY
9	06504045	4	PIN, DOWEL
10	-----	1	NAME PLATE
11	763759	2	THRUST PLATE
12	02961940	1	PLUG, HEX
13	TF4401	1	RING, SNAP
14	06504049	1	SEAL, LIP
15	TF4410	2	SEAL, GASKET
16	06504046	4	SEAL, SIDE
17	06504047	4	SEAL, END
18	TF4407	2	SEAL, BACK-UP
19	06504048	1	RETAINER, SEAL
20	6T5809	2	CHECK ASSEMBLY
21	02961917	4	WASHER

BOOM TRAVEL LOCK

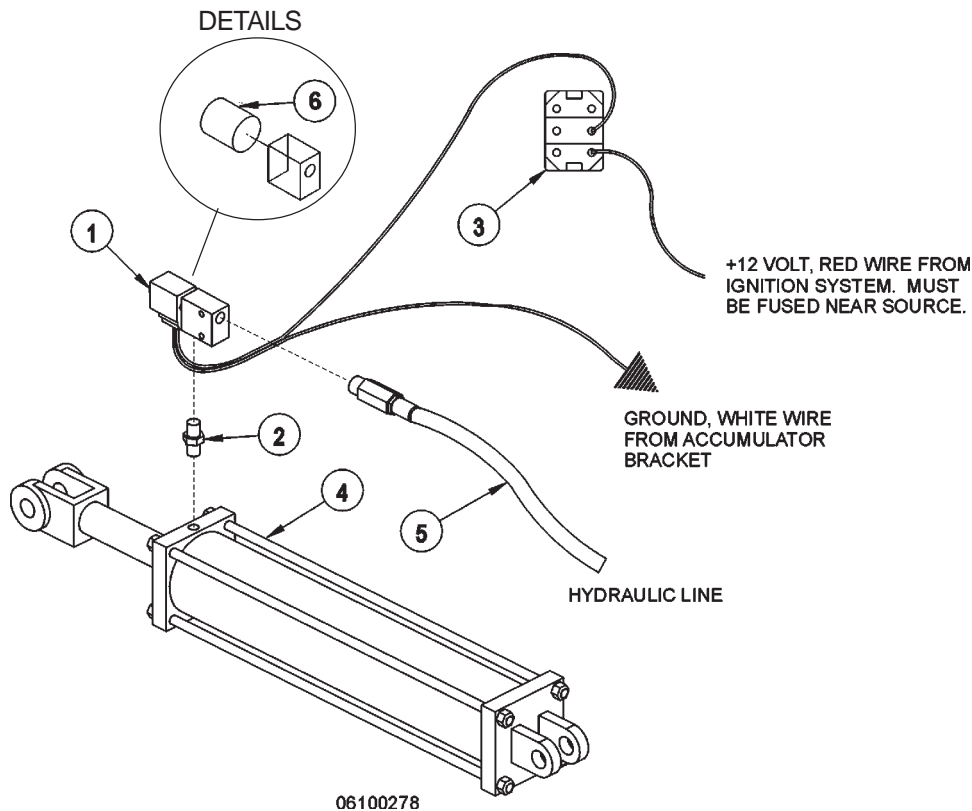

Danfoss Switch Box



Husco Switch Box



OLDER UNITS ONLY, SWITCH ON NEWER MODELS IN SWITCHBOX
Refer to your switchbox before drilling hole or wiring.

For cab units, drill a hole in an open area on the right side of the dash panel and install the toggle switch. For non-cab units, use the mounting bracket included to install the toggle switch on the under side of the valve stand. Install the decal for the toggle switch operation directly by the toggle switch.

ITEM	PART NO.	QTY.	DESCRIPTION
1	31328	1	HYDRAULIC TRAVEL LOCK VALVE
2	31329	1	ADAPTER - STANDARD BOOM
2A	31611	OPT.	ADAPTER - EXTENDED BOOM
3	34532	1	SWITCH, TRAVEL LOCK
4	*	REF.	MAIN BOOM CYLINDER - REFER OT BOOM ASY
5	*	REF.	HOSE / FITTINGS - REFER TO BOOM ASY
6	34796	1	COIL, TRAVEL LOCK

HUSCO CONTROLS SWITCHBOX

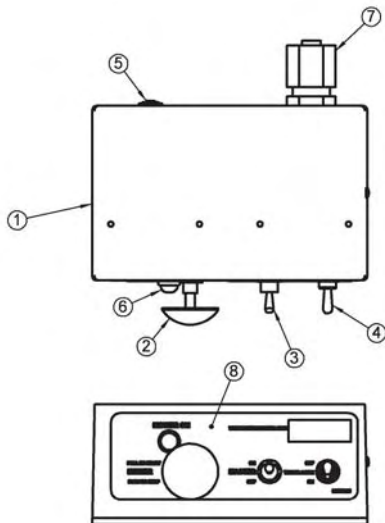
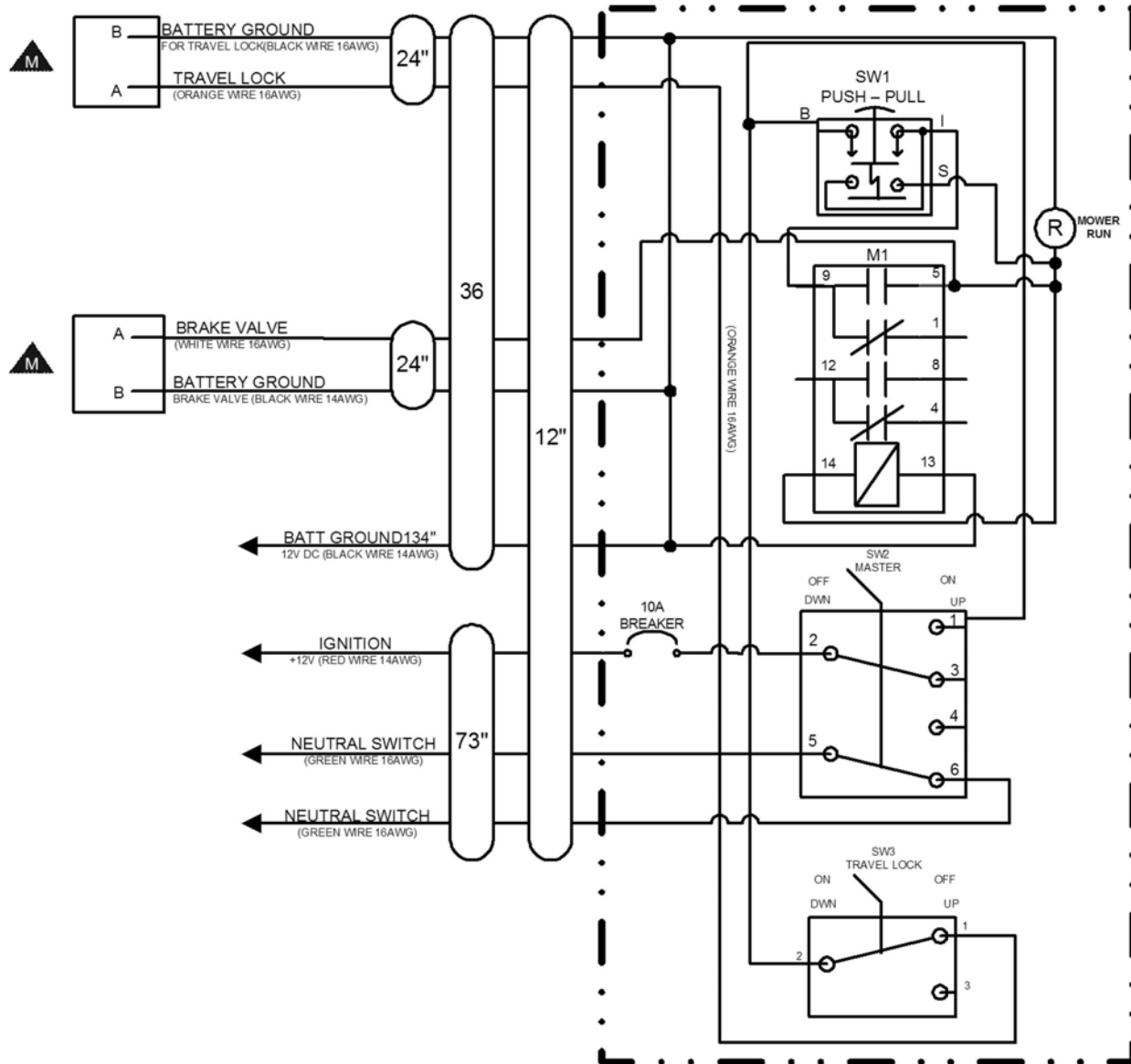

ITEM	P/N	QTY.	DESCRIPTION
1	06514012	1	SWBX,ALUM,BLK,06510100
2	35226	1	SWITCH,MOWER,COLEHERSEE
3	33811	1	SWITCH,MASTER/DECK FLOAT
4	34532	1	SWITCH,TRVL LCK
5	06514014	1	BREAKER,10A,SWBX
6	6T3923	1	INDICTATOR LIGHT,ON,RED
7	34540	1	STRAIN RELIEF,3/4,BLACK,NYLON
8	06550019	1	DECAL,SWTCHBX,BOOM,CG
9	35227	1	RELAY,DP,DT,12V,LY2F,35226

JOYSTICK AND SWITCH BOX WIRING

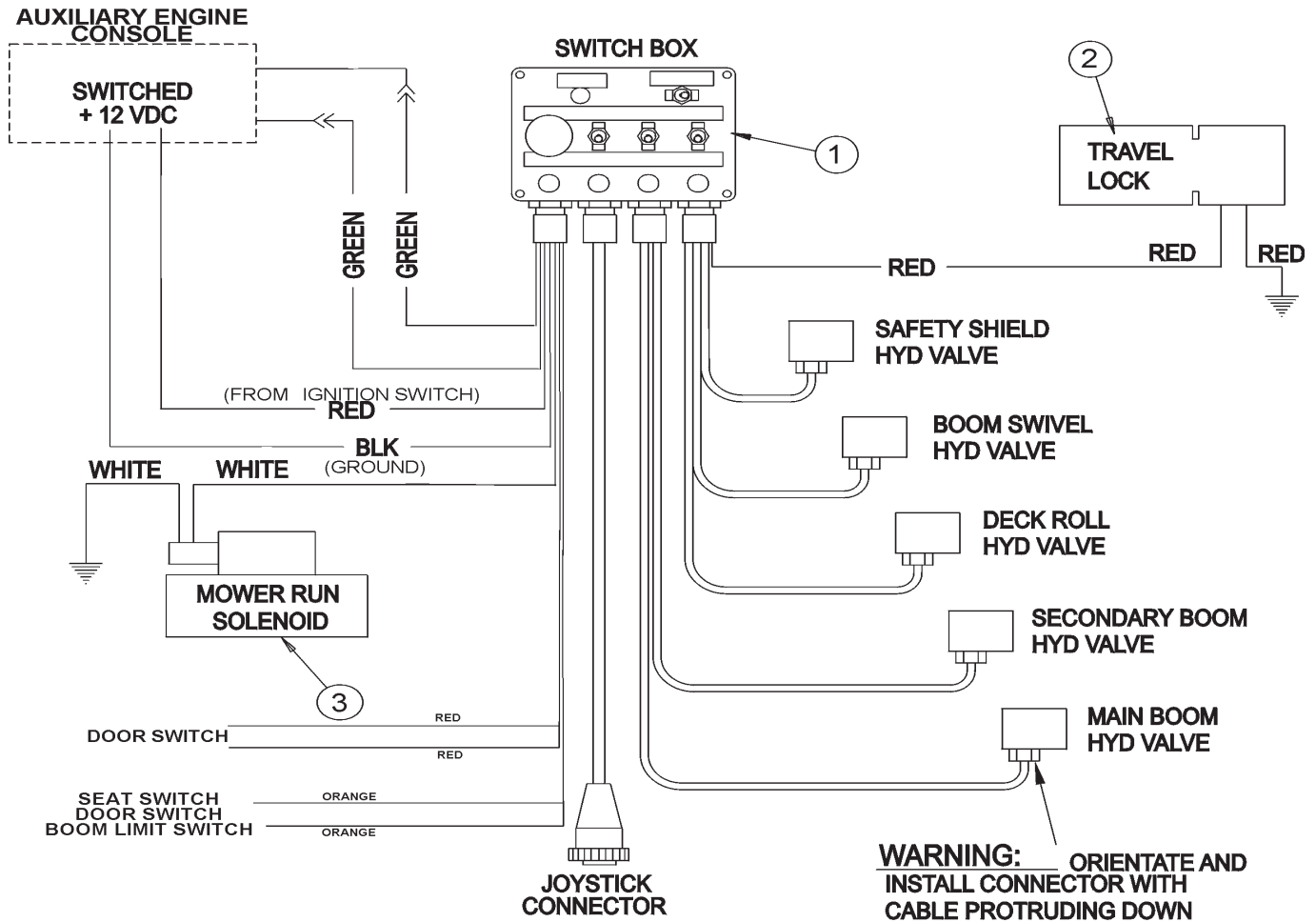

32731

ITEM	PART NO.	QTY.	DESCRIPTION
1	6T3934	OPT.	OIL TEMPERATURE GAUGE
2	6T3931	OPT.	TEMPERATURE SENSOR
3	REF.	*	SWITCH BOX - REFER TO LIFT VALVE
4	REF.	*	TRAVEL LOCK - REFER TO HYDRAULICS
5	REF.	*	SOLENOID - REFER TO MAIN FRAME

JOYSTICK SWITCHBOX SERVICE PARTS

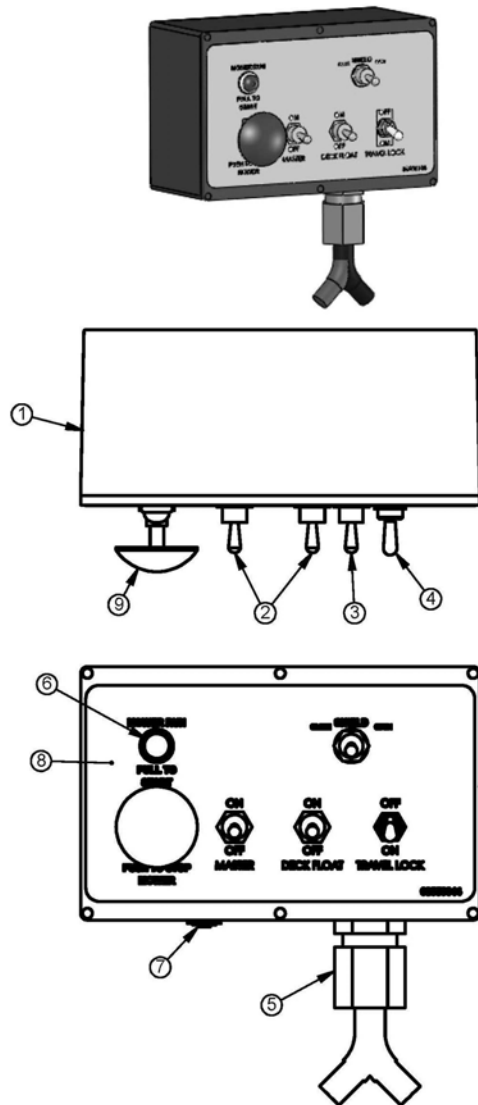

ITEM	P/N	QTY.	DESCRIPTION
1	06510196	1	SWBX,ALUM,ASSY
2	33811	2	SWITCH,MASTER/DECK FLOAT
3	33813	1	SWITCH,SFTY SHIELD
4	34532	1	SWITCH,TRVL LCK
5	34540	1	STRAIN RELIEF,3/4,BLACK,NYLON
6	6T3923	1	INDICTATOR LIGHT,ON,RED
7	06514006	1	BREAKER,15A,SWBX
8	06550044	1	DECAL,SWBX,06510047
9	35226	1	SWITCH,MOWER,COLEHERSEE
10	35227	1	RELAY,DP,DT,12V,LY2F,35226

JOYSTICK SWITCHBOX SCHEMATIC

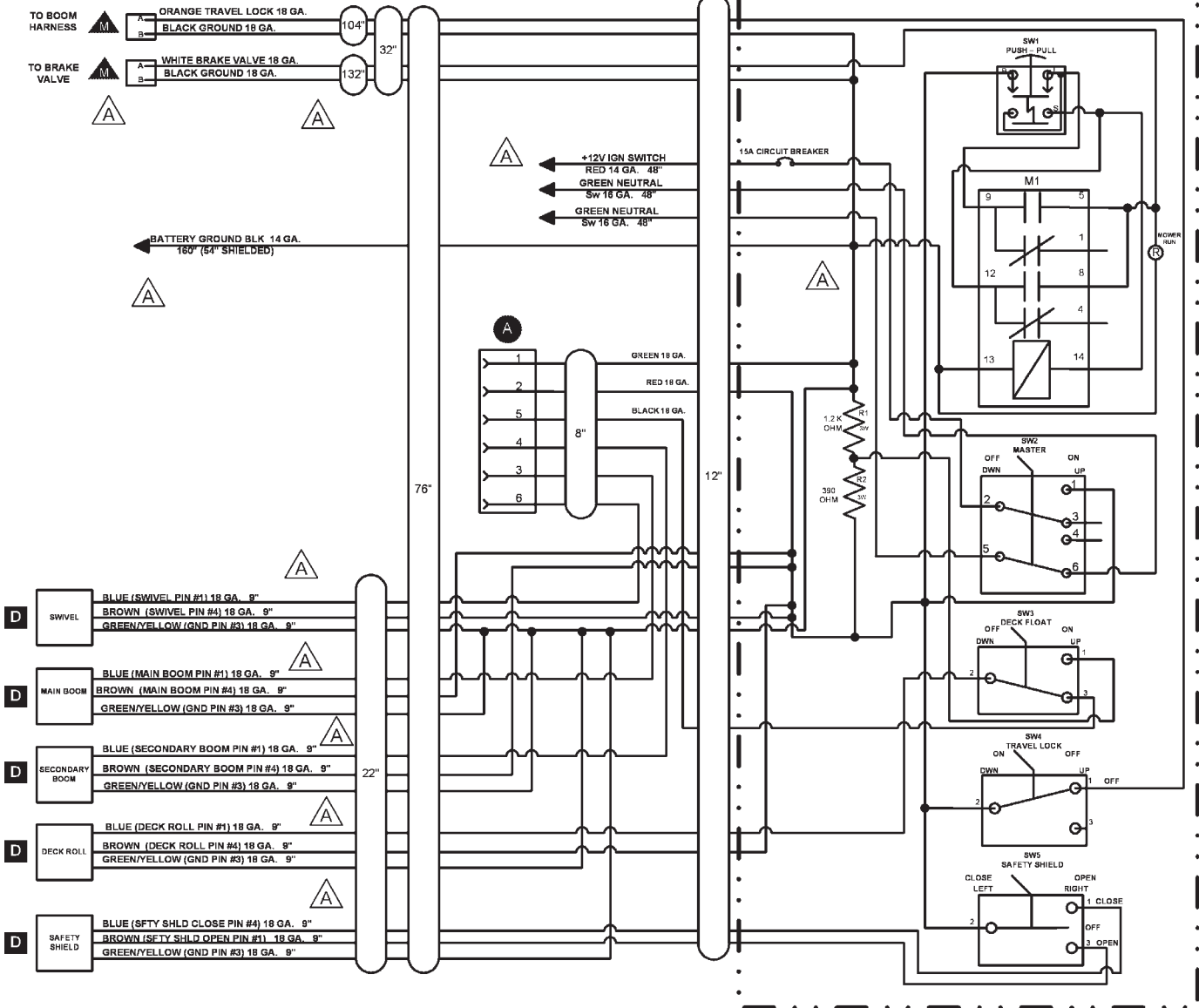

BRAKE VALVE ASSEMBLY

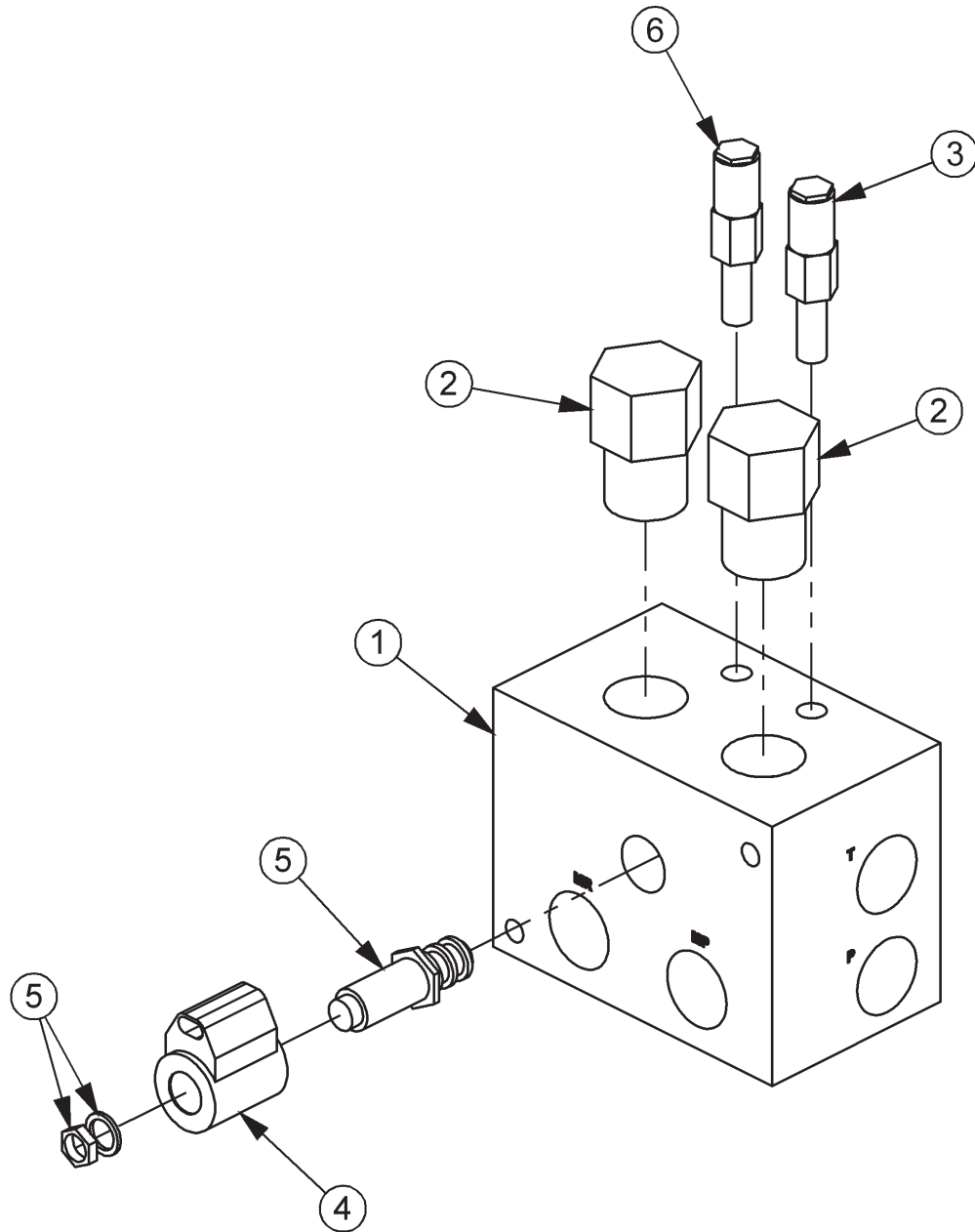

ITEM	PART NO.	QTY.	DESCRIPTION
*	06510083	AVAIL	BRAKE VALVE, ASSY
1	34092	1	BRAKE VALVE, BLANK
2	34094	2	LOGICELEMENT
3	34095	1	RELIEF VALVE, 3000 PSI
4	06510095	1	METRIPAK COIL
5	34093	1	CARTRIDGE, 2 POSITION, 3 WAY (WITH NUT & WASHER)
6	34091	1	RELIEF VALVE, 2600 PSI

BRAKE VALVE HYDRAULIC SCHEMATIC

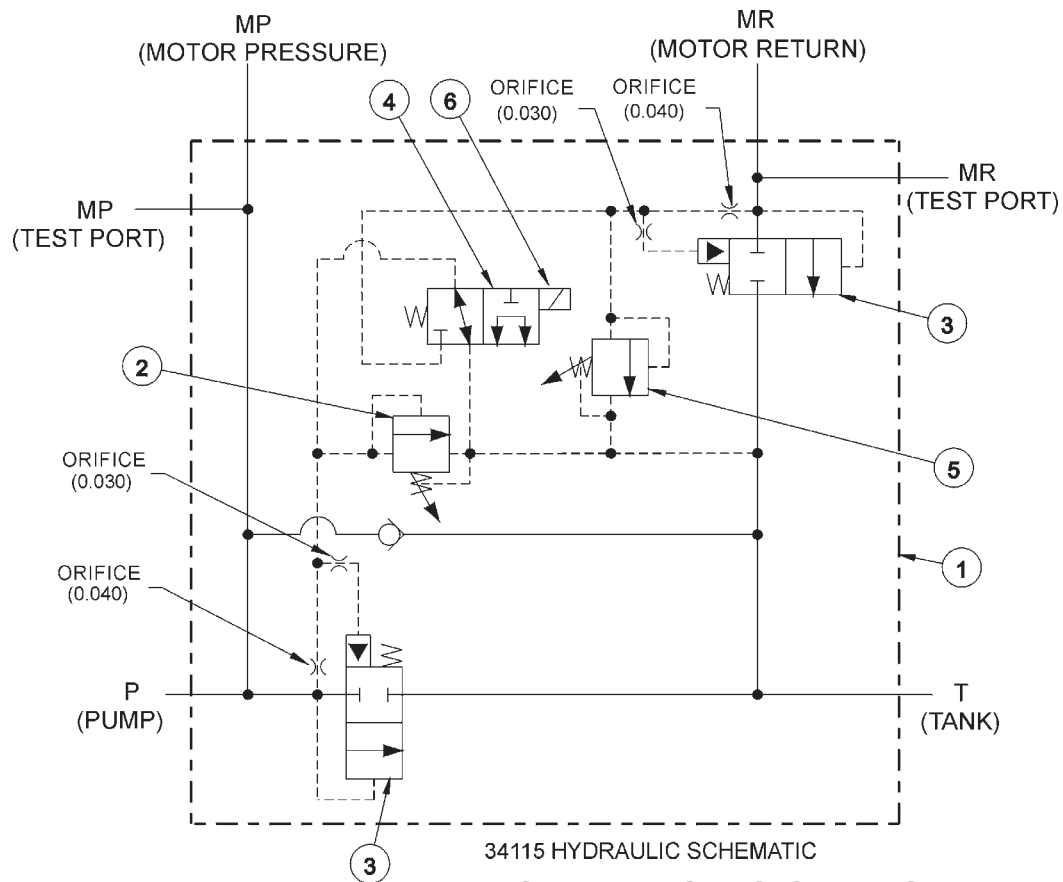

BRAKE VALVE TROUBLESHOOTING

FAILURE MODE:

- MOWER WILL NOT START - system pressure is low (engine not lugging).
- MOWER WILL NOT START - system pressure is high (engine lugging). "MR" port will be high pressure.
- MOWER WILL NOT ROTATE AT FULL SPEED - limited power.
- MOWER BLADE WILL NOT STOP - blade will not stop in proper time.

CHECK STEPS

- 1 thru 6
- 7
- 3 thru 5
- 7 thru 9

CORRECTIVE STEPS:

1. Check for voltage at solenoid (item 6), voltage must be between 10.2 volts and 13.8 volts.
2. Remove, inspect solenoid and cartridge (items 4, 6) for wear or contamination.
3. Remove, inspect logic elements near "P" port (item 3) for wear or contamination.
4. Remove, inspect 3000 psi relief valve (item 2) for wear or contamination.
5. Remove and inspect orifices near "P" port for contamination.
6. Remove "P" port hose and fitting, visually inspect for contamination, check ball for movement.
7. Remove and inspect orifices near "MR" port for contamination.
8. Remove, inspect 2600 psi relief valve (item 5) for wear or contamination.
9. Remove, inspect logic element near "MR" port (item 3) for wear or contamination.

ELECTRICAL - TROUBLESHOOTING GUIDE

Danfoss Electrical Troubleshooting guide

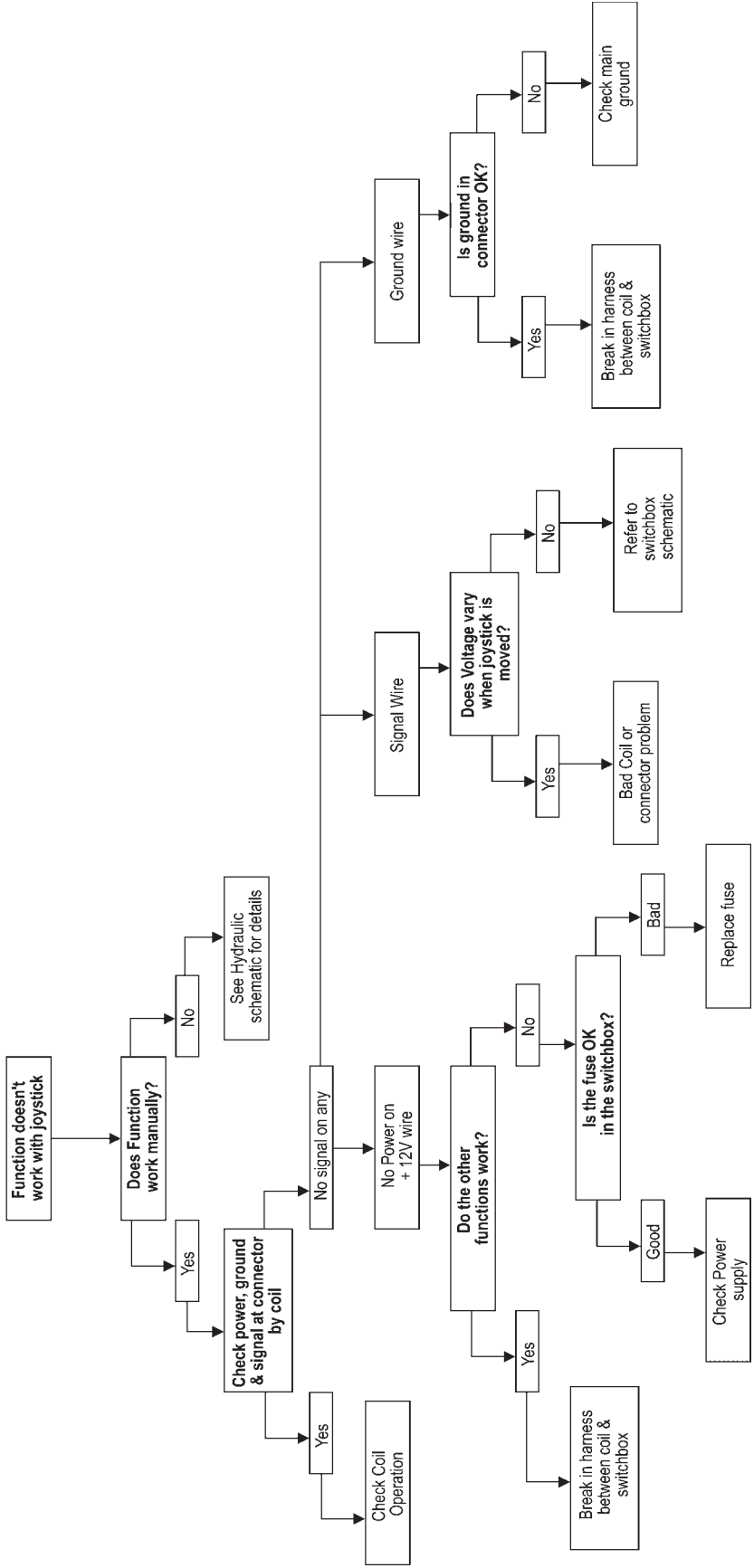

HYDRAULIC - TROUBLESHOOTING GUIDE

Hydraulic Troubleshooting guide

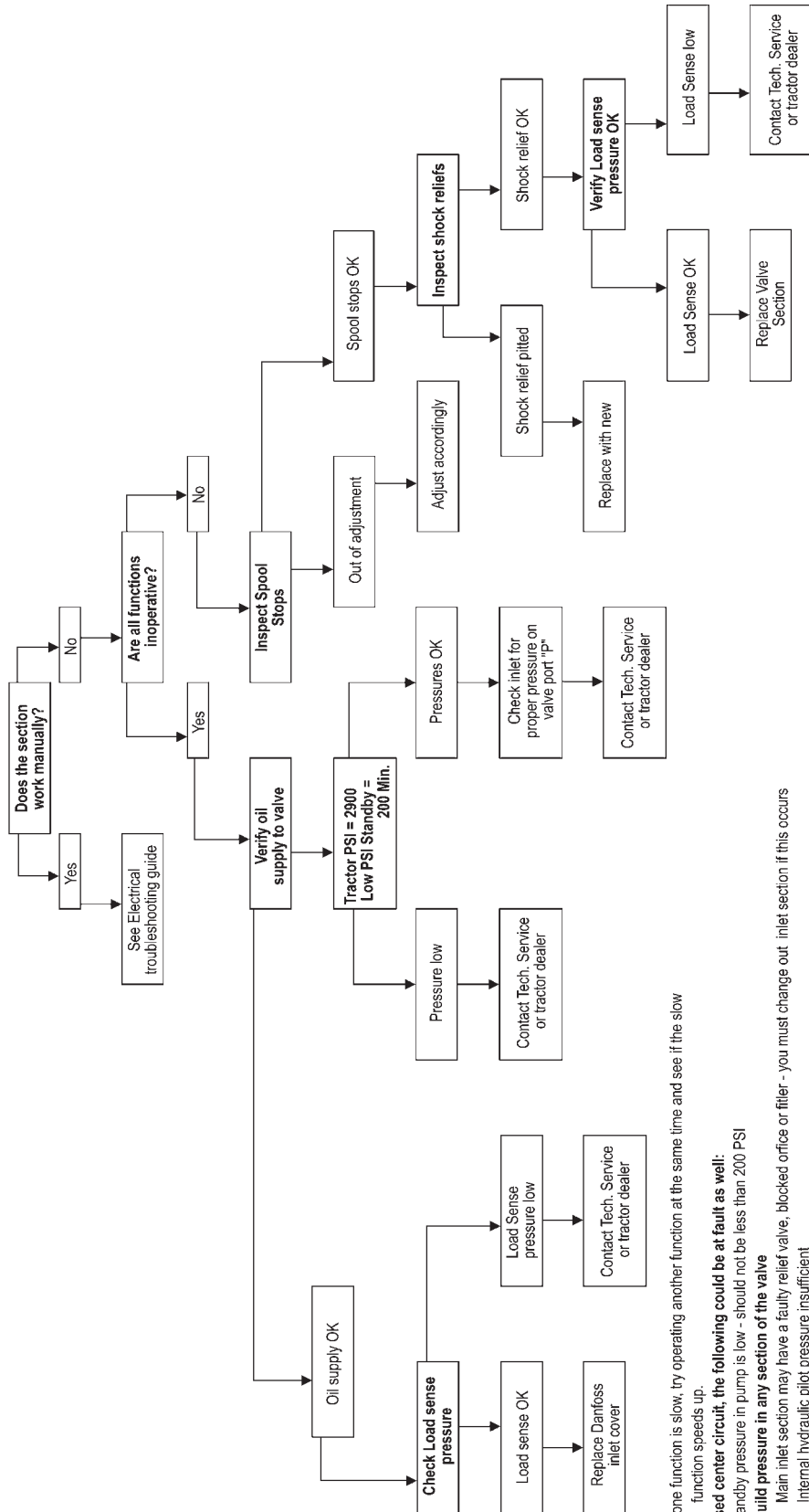

Notes: If one function is slow, try operating another function at the same time and see if the slow function speeds up.

On a closed center circuit, the following could be at fault as well:

Tractor standby pressure in pump is low - should not be less than 200 PSI

Cannot build pressure in any section of the valve

Main inlet section may have a faulty relief valve, blocked orifice or filler - you must change out inlet section if this occurs

Internal hydraulic pilot pressure insufficient

TROUBLESHOOTING

JOYSTICK TROUBLESHOOTING

Boom operation not responding to joystick movement.

Isolate hydraulic vs. electronic symptom.

Turn off electronic master switch (preventing electronic actuator on valve from attempting to hold spool in neutral position). With tractor engine running, operate the valve section with the manual handle. If function operates normally, continue with electronic inspection. If function does not operate normally, continue with hydraulic inspection.

Electronic inspection.

Connect a voltmeter to the cable connector of the valve section that is not operating. This will allow you to measure supply and signal voltage when the joystick is operated.

Main, Secondary, and Swivel Valves – signal voltage should be 50% of supply voltage with joystick in Neutral position, up to 75% of supply voltage in B direction, down to 25% of supply voltage in A direction. Signal voltage should change smoothly with lever movement.

Pin #1 – Supply Voltage Pin #2 – Signal Voltage Pin #gnd – ground

Deck Roll Valve or Float Valve – signal voltage should be 50% of supply voltage with joystick in Neutral position, up to 65% of supply voltage in B direction, down to 35% of supply voltage in A direction. Signal voltage should change smoothly with lever movement. Signal voltage should be approximately 75% of supply voltage when float switch is operated.

Pin #1 – Supply Voltage Pin #2 – Signal Voltage Pin #gnd – ground

Shield Valve or On/Off Valve – Voltage on pin #1 should be equal to supply voltage when switch is operated in A direction. Voltage on pin #2 should be equal to supply voltage when switch is operated in B direction.

Pin #1 – Signal Voltage Pin #2 – Signal Voltage Pin #gnd – ground

If none of the valve will operate with electrical signal, verify that there is oil pressure at the valve inlet. Electrical Valves must have pilot supply oil to move the spools.

Possible electronic problems.

Open circuit (broken wire, bad connection or loose connection in switch box).
Shorted to positive, ground, or other.
Incorrect voltage signal from joystick.

TROUBLESHOOTING

Hydraulic inspection.

Install 3 pressure gauges, on the valve inlet (use M port, or tee into hose supplying oil from the pump to the inlet), on the workport that is not operating, and on the LS port.

With the spools in Neutral

Gear pump – P should be approximately 200 psi, LS = 0, workport – pressure on cylinder or function.

LS pump – P should equal pump standby pressure, LS = 0, workport – pressure on cylinder or function.

Pressure Comp pump – P should equal pump standby pressure, LS = 0, workport – pressure on cylinder or function.

Gear pump – P should be approximately 200 psi higher than LS, LS should equal workport, workport – pressure on cylinder or function.

LS pump – P should be LS + standby, LS should equal workport, workport – pressure on cylinder or function.

Pressure Comp pump – P should equal pump standby pressure, LS should equal workport, workport – pressure on cylinder or function.

Operate one spool, measure pressures with function at end of travel or stop

Gear pump – P should equal valve relief setting or workport shock valve setting. LS should equal workport. Workport should equal relief setting or workport shock valve setting.

LS pump – P should equal valve relief setting, pump max pressure setting, or workport shock valve setting. LS should equal workport. Workport should equal relief setting, pump max pressure setting, or workport shock valve setting.

Pressure Comp pump – P should equal pump standby pressure, LS should equal workport. Workport should equal pump standby pressure or workport shock valve setting.

Operate more than one spool.

Gear pump – P should approximately 200 psi higher than LS. LS should equal highest workport pressure. Workport – pressure on cylinder or function.

LS pump – P should be LS + standby pressure. LS should equal highest workport pressure. Workport – pressure on cylinder or function.

Pressure Comp pump. P should equal pump standby pressure. LS should equal highest workport pressure. Workport – pressure on cylinder or function.

Possible hydraulic problems.

Cylinder leak.

LS signal leaking to tank before reaching pump LS port.

Hydraulic system or pump not supplying flow to valve.

WARRANTY SECTION

WARRANTY INFORMATION

Tiger Corporation, 3301 N. Louise, Sioux Falls, South Dakota, warrants to the original Retail Customer, the new Tiger equipment is free of defects in material and workmanship. Any part of equipment that in Tiger's judgement, show evidence of such defects will be repaired or replaced without charge, provided that the failure of part(s) shall have occurred within twelve (12) months from the date of delivery of said equipment to the Retail Customer. Expendable components such as knives, oil, chain sprockets, skid shoes, knife mounting disks and the like are excluded but not limited to this warranty.

The Retail Customer must pay the transportation cost to and from the Tiger Dealer's service shop for warranty service. Warranty service will be performed by the Tiger Dealer from whom the equipment was purchased, during service shop regularly scheduled days and hours of operation.

All Tiger obligation under this warranty shall be terminated if the equipment is modified or altered in ways not approved in writing by Tiger, if repair parts other than genuine Tiger repair parts have been used, or if the equipment has been subject to misuse, neglect, accident, improper maintenance or improper operation.

Tiger Corporation reserves the right to make improvements in design or changes in specification at any time without incurring any obligation to owners of equipment previously sold.

No agent or person has authority to alter, add to or waive the above warranties which are agreed to be in the only warranties, representations or promises, expressed or implied, as to the quality or performance of the products covered and which do not include any implied warranty of merchantability or fitness. In no event will Tiger be liable for incidental or consequential damages or injuries, including, but not limited to, loss of profits, rental or substitute equipment or other commercial loss.

**THERE ARE NO WARRANTIES WHICH EXTEND
BEYOND THOSE EXPRESSED HEREIN.**

It is the Purchasers obligation to sign the warranty registration form **AFTER** he / she has Read and Understands the Operation and Safety Instructions stated within this manual.

ONE LAST WORD

This manual cannot possibly cover all of the potentially hazardous situations you will encounter. By being familiar with the safety rules, operating and maintenance instructions in this manual you can help prevent accidents. The objective of this manual is to help make you a better operator. Remember, **SAFETY IS YOU!**



1012

Your safety and the safety of those around you depends on **YOU**. Common sense should play a large role in the operation of this machine.

Since we at Tiger Corporation are constantly striving to improve our products, we reserve the right to change specifications or design at any time.

TO THE OWNER / OPERATOR / DEALER



To keep your implement running efficiently and safely, read your manual thoroughly and follow these directions and the Safety Messages in this manual and on the machine. The table of contents clearly identifies each section where you can easily find the information you need.

The Occupational Safety and Health Act (OSHA 1928.51 subpart C) makes the following minimum requirements for tractor operators.

OWNER REQUIREMENTS:

1. Provide a Roll-Over-Protective Structure that meets the requirements of this Standard; and
2. Provide Seatbelts that meet the requirements of this Standard and SAE J3C; and
3. Ensure that each employee uses such Seatbelt while the tractor is moving; and
4. Ensure that each employee tightens the Seatbelt sufficiently to confine the employee to the protected area provided by the ROPS.

OPERATOR REQUIREMENTS:

1. Securely fasten seatbelt if the tractor has a ROPS.
2. Where possible, avoid operating the tractor near steep ditches, embankments, and holes.
3. Reduce speed when turning, crossing slopes, and on rough, slick, or muddy surfaces.
4. Stay off slopes too steep for safe operation.
5. Watch where you are going – especially at row ends, on roads, and around trees.
6. Do Not permit others to ride.
7. Operate the tractor smoothly – no jerky turns, starts, or stops.
8. Hitch only to the draw-bar and hitch points recommended by the tractor manufacturer.
9. When the tractor is stopped, set brakes securely and use park lock, if available



Printed in USA
© Tiger Corporation