



# REAR STOW SIDE BOOM ASSEMBLIES

JD6xxxD

Current as of 03/29/2014

---



PARTS LISTING WITH  
MOUNTING AND OPERATING  
INSTRUCTIONS

---

**Tiger Corporation**  
3301 N. Louise Ave.  
Sioux Falls, SD 57107  
1-800-843-6849  
1-605-336-7900  
[www.tiger-mowers.com](http://www.tiger-mowers.com)

06011021

# TO THE OWNER / OPERATOR / DEALER

All implements with moving parts are potentially hazardous. There is no substitute for a cautious, safe-minded operator who recognizes the potential hazards and follows reasonable safety practices. The manufacturer has designed this implement to be used with all its safety equipment properly attached to minimize the chance of accidents.

**BEFORE YOU START!!** Read the safety messages on the implement and shown in this manual. Observe the rules of safety and use common sense!

**READ AND UNDERSTAND THIS MANUAL! Non-English speaking operators will need to GET THE MANUAL TRANSLATED as needed!**



# DANGER

**FAILING TO FOLLOW SAFETY MESSAGES AND OPERATING INSTRUCTIONS CAN CAUSE SERIOUS BODILY INJURY OR EVEN DEATH TO OPERATOR AND OTHERS IN THE AREA.**

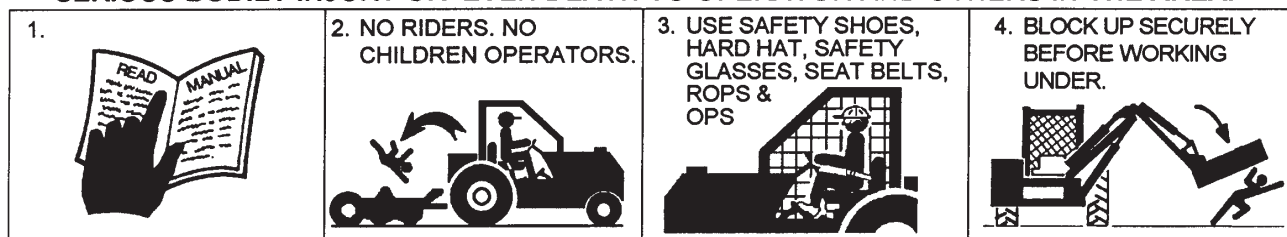

1. Study and understand Operator's Manuals, Safety Decals, and Instructional Decals for tractor and implement to prevent misuse, abuse, and accidents. Practice before operating in a confined area or near passersby.

● Learn how to stop engine suddenly in an emergency. Be alert for passersby and especially children

2. Allow no children on or near folding mower or tractor. Allow no riders on tractor or implement. Falling off may cause serious injury or death from being run over by tractor or mower or contact with rotating blades.

3. Operate only with tractor having Roll-Over Protective Structure (ROPS) and with seat belt securely fastened to prevent injury and possible death from falling off or tractor overturn.

● Personal Protective Equipment such as Hard Hat, Safety Glasses, Safety Shoes, & Ear Plugs are recommended.

4. Block up or support raised machine and all lifted components securely before putting hands or feet under or working underneath any lifted component to prevent crushing injury or death from sudden dropping or inadvertent operation of controls. Make certain area is clear before lowering or folding

5. Before transporting, put Lift Lever in detent or full-lift position. Install Transport Safety Devices securely on folding mowers. Put Booms securely in Transport Rest.

● Folding and Boom Mowers have raised center of gravity. Slow down when turning and on hillsides.

6. Make certain that SMV sign, warning lights, and reflectors are clearly visible. Follow local traffic codes.

7. Never operate with Cutting Head or Folding Section raised if passersby, bystanders, or traffic are in the area to reduce possibility of injury or death from objects thrown by Blades under Guards or mower structure.

8. Before dismounting, secure implement in transport position or lower to ground.

● Put tractor in park or set brake, disengage PTO, stop engine, remove key, and wait until noise of rotation has ceased to prevent crushing by entanglement in rotating parts which could cause injury or death.

● Never mount or dismount a moving vehicle. Crushing from rollover may cause serious injury or death.

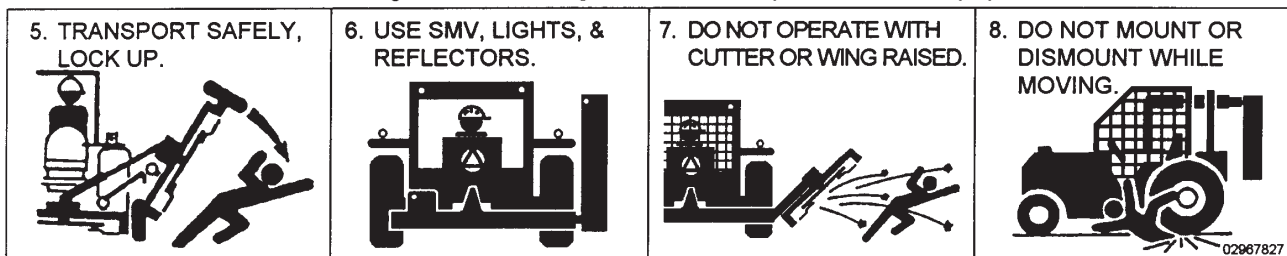

02967827

Warranty Information: Read and understand the complete Warranty Statement found in this manual. Fill out the Warranty Registration form in full and return it within 90 days. Make certain the Serial Number of the machine is recorded on the Warranty Card, and form that you retain.

# FORWARD

This manual contains information about many features of the Tiger mowing and roadside maintenance equipment. Some of these include: Safety precautions, Assembly instructions, Operations, Maintenance and Parts. This manual will also assist you in the proper break-in, daily care, and troubleshooting of your new mower.

We recommend that you read carefully the entire manual before operating the unit. Also, time spent in becoming fully acquainted with its performance features, adjustments, and maintenance schedules will be repaid in a long and satisfactory life of the equipment.

## **Troubleshooting - Please, before you call, help us to help you!**

Please look at the equipment to observe what is happening, then:

- Classify the problem
  - Hydraulic, electrical or mechanical - Read the trouble shooting section
  - Tractor or Truck chassis - Contact vehicle dealer
  
- If unable to correct the problem yourself, contact your local Tiger Dealer after gathering:
  - Machine model \_\_\_\_\_
  - Serial number \_\_\_\_\_
  - Dealer name \_\_\_\_\_
  - Detailed information about the problem including results of troubleshooting

**Attention Owner / Operator / Dealer:** It is your obligation to read, and understand, the warranty information section located at the back of this manual denoting that the purchaser understands the safety issues relating to this machine and has received and will read a copy of this manual.

If at any time, you have a service problem with your Tiger mower, Contact your local dealer for service and parts needed.

MANUFACTURED BY:

**Tiger Corporation**

3301 N. Louise Ave.

Sioux Falls, SD 57107

1-800-843-6849

1-605-336-7900

www.tiger-mowers.com

DISTRIBUTED BY:

\_\_\_\_\_

1- \_\_\_\_\_ - \_\_\_\_\_ - \_\_\_\_\_

1- \_\_\_\_\_ - \_\_\_\_\_ - \_\_\_\_\_



# TABLE OF CONTENTS

SAFETY SECTION_____	1
ASSEMBLY / MOUNTING SECTION_____	2
OPERATION SECTION_____	3
MAINTENANCE SECTION_____	4
PARTS SECTION_____	5
COMMON PARTS SECTION_____	6
WARRANTY INFORMATION_____	7



1012

**This symbol means:**

**CAUTION – YOUR SAFETY IS AT RISK!**

When you see this symbol, read and follow the associated instructions carefully or personal injury or damage may result.

Tiger is a registered trademark.





# SAFETY

# SAFETY SECTION

# SAFETY

## General Safety Instructions and Practices

A safe and careful operator is the best operator. Safety is of primary importance to the manufacturer and should be to the owner / operator. Most accidents can be avoided by being aware of your equipment, your surroundings, and observing certain precautions. The first section of this manual includes a list of Safety Messages that, if followed, will help protect the operator and bystanders from injury or death. Read and understand these Safety Messages before assembling, operating or servicing this mower. This equipment should only be operated by those persons who have read the Manual, who are responsible and trained, and who know how to do so safely and responsibly.



1000

The Safety Alert Symbol combined with a Signal Word, as seen below, is used throughout this manual and on decals which are attached to the equipment. The Safety Alert Symbol means: “**ATTENTION! BECOME ALERT! YOUR SAFETY IS INVOLVED!**” The symbol and signal word are intended to warn the owner / operator of impending hazards and the degree of possible injury when operating this equipment.

**Practice all usual and customary safe working precautions and above all -- remember safety is up to YOU! Only YOU can prevent serious injury or death from unsafe practices.**

DANGER!



Indicates an imminently hazardous situation that, if not avoided, WILL result in DEATH OR VERY SERIOUS INJURY.

WARNING!



Indicates an imminently hazardous situation that, if not avoided, COULD result in DEATH OR SERIOUS INJURY.

CAUTION!



Indicates an imminently hazardous situation that, if not avoided, MAY result in MINOR INJURY.

**IMPORTANT!**

Identifies special instructions or procedures that, if not strictly observed, could result in damage to, or destruction of the machine, attachments or the environment.

**NOTE:** *Identifies points of particular interest for more efficient or convenient operation or repair.* (SG-1)

READ, UNDERSTAND, and FOLLOW the following Safety Messages. Serious injury or death may occur unless care is taken to follow the warnings and instructions stated in the Safety Messages. Always use good common sense to avoid hazards. (SG-2)

**SAFETY INSTRUCTIONS**





# SAFETY

**PELIGRO!**



Si no lee Ingles, pida ayuda a alguien que si lo lea para que le traduzca las medidas de seguridad. (SG-3)



**¡ LEA EL INSTRUCTIVO!**

**DANGER!**



Never operate the Tractor or Implement until you have read and completely understand this Manual, the Tractor Operator's Manual, and each of the Safety Messages found in the Manual or on the Tractor and Implement. Learn how to stop the tractor engine suddenly in an emergency. Never allow inexperienced or untrained personnel to operate the Tractor and Implement without supervision. Make sure the operator has fully read and understood the manuals prior to operation. (SG-4)

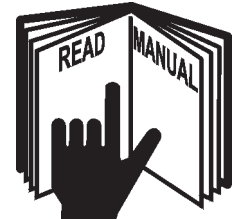

**WARNING!**



Always maintain the safety decals in good readable condition. If the decals are missing, damaged, or unreadable, obtain and install replacement decals immediately. (SG-5)

**WARNING!**



Make certain that the "Slow Moving Vehicle" (SMV) sign is installed in such a way as to be clearly visible and legible. When transporting the Equipment use the Tractor flashing warning lights and follow all local traffic regulations. (SG-6)



**WARNING!**



Operate this Equipment only with a Tractor equipped with an approved roll-over-protective system (ROPS). Always wear seat belts. Serious injury or even death could result from falling off the tractor--particularly during a turnover when the operator could be pinned under the ROPS. (SG-7)



**WARNING!**



Do not modify or alter this Implement. Do not permit anyone to modify or alter this Implement, any of its components or any Implement function. (SG-8)

**DANGER!**



BEFORE leaving the tractor seat, always engage the brake and/or set the tractor transmission in parking gear, disengage the PTO, stop the engine, remove the key, and wait for all moving parts to stop. Place the tractor shift lever into a low range or parking gear to prevent the tractor from rolling. Never dismount a Tractor that is moving or while the engine is running. Operate the Tractor controls from the tractor seat only. (SG-9)

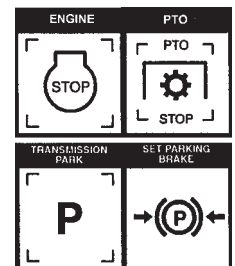

# SAFETY

**DANGER!**



Never allow children or other persons to ride on the Tractor or Implement. Falling off can result in serious injury or death.

(SG-10)



**DANGER!**



Never allow children to operate or ride on the Tractor or Implement.

(SG-11)



**WARNING!**



Do not mount the Tractor while the tractor is moving. Mount the Tractor only when the Tractor and all moving parts are completely stopped.

12)

(SG-



**DANGER!**



Start tractor only when properly seated in the Tractor seat. Starting a tractor in gear can result in injury or death. Read the Tractor operators manual for proper starting instructions. (SG-13)



**DANGER!**



Never work under the Implement, the framework, or any lifted component unless the Implement is securely supported or blocked up to prevent sudden or inadvertent falling which could cause serious injury or even death. (SG-14)



**DANGER!**



Do not operate this Equipment with hydraulic oil leaking. Oil is expensive and its presence could present a hazard. Do not check for leaks with your hand! Use a piece of heavy paper or cardboard. High-pressure oil streams from breaks in the line could penetrate the skin and cause tissue damage including gangrene. If oil does penetrate the skin, have the injury treated immediately by a physician knowledgeable and skilled in this procedure. (SG-15)



# SAFETY

## WARNING!



The operator and all support personnel should wear hard hats, safety shoes, safety glasses, and proper hearing protection at all times for protection from injury including injury from items thrown by the equipment. (SG-16)

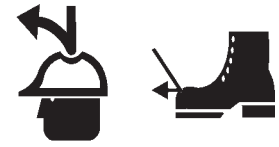

## CAUTION!



**PROLONGED EXPOSURE TO LOUD NOISE MAY CAUSE PERMANENT HEARING LOSS!** Tractors with or without an Implement attached can often be noisy enough to cause permanent hearing loss. We recommend that you always wear hearing protection if the noise in the Operator's position exceeds 80db. Noise over 85db over an extended period of time will cause severe hearing loss. Noise over 90db adjacent to the Operator over an extended period of time will cause permanent or total hearing loss. *Note:* Hearing loss from loud noise [from tractors, chain saws, radios, and other such sources close to the ear] is cumulative over a lifetime without hope of natural recovery. (SG-17)



## WARNING!



Transport only at safe speeds. Serious accidents and injuries can result from operating this equipment at unsafe speeds. Understand the Tractor and Implement and how it handles before transporting on streets and highways. Make sure the Tractor steering and brakes are in good condition and operate properly.



**Before transporting the Tractor and Implement, determine the safe transport speeds for you and the equipment. Make sure you abide by the following rules:**

1. Test the tractor at a slow speed and increase the speed slowly. Apply the Brakes smoothly to determine the stopping characteristics of the Tractor and Implement. As you increase the speed of the Tractor the stopping distance increases. Determine the maximum safe transport speed for you and this Equipment.
2. Test the equipment at a slow speed in turns. Increase the speed through the turn only after you determine that it is safe to operate at a higher speed. Use extreme care and reduce your speed when turning sharply to prevent the tractor and implement from turning over. Determine the maximum safe turning speed for you and this equipment before operating on roads or uneven ground.
3. Only transport the Tractor and Implement at the speeds that you have determined are safe and which allow you to properly control the equipment.



**Be aware of the operating conditions. Do not operate the Tractor with weak or faulty brakes. When operating down a hill or on wet or rain slick roads, the braking distance increases: use extreme care and reduce your speed. When operating in traffic always use the Tractor's flashing warning lights and reduce your speed. Be aware of traffic around you and watch out for the other guy.** (SG-19)

# SAFETY

**WARNING!**



Never attempt to lubricate, adjust, or remove material from the Implement while it is in motion or while tractor engine is running. Make sure the tractor engine is off before working on the Implement.

(SG-20)

**WARNING!**



Periodically inspect all moving parts for wear and replace when necessary with authorized service parts. Look for loose fasteners, worn or broken parts, and leaky or loose fittings. Make sure all pins are properly secured. Serious injury may occur from not maintaining this machine in good working order. (SG-21)



**WARNING!**



Always read carefully and comply fully with the manufacturers instructions when handling oil, solvents, cleansers, and any other chemical agent. (SG-22)



**DANGER!**



Never run the tractor engine in a closed building or without adequate ventilation. The exhaust fumes can be hazardous to your health.

(SG-23)

**DANGER!**



KEEP AWAY FROM ROTATING ELEMENTS to prevent entanglement and possible serious injury or death.

(SG-24)



**DANGER!**



Never allow children to play on or around Tractor or Implement. Children can slip or fall off the Equipment and be injured or killed. Children can cause the Implement to shift or fall crushing themselves or others. (SG-25)

# SAFETY

## DANGER!



**NEVER use drugs or alcohol** immediately before or while operating the Tractor and Implement. Drugs and alcohol will affect an operator's alertness and coordination and therefore affect the operator's ability to operate the equipment safely. Before operating the Tractor or Implement, an operator on prescription or over-the-counter medication must consult a medical professional regarding any side effects of the medication that would hinder their ability to operate the Equipment safely. **NEVER** knowingly allow anyone to operate this equipment when their alertness or coordination is impaired. Serious injury or death to the operator or others could result if the operator is under the influence of drugs or alcohol. (SG-27)



## DANGER!



Operate the Tractor and/or Implement controls only while properly seated in the Tractor seat with the seat belt securely fastened around you. Inadvertent movement of the Tractor or Implement may cause serious injury or death. (SG-29)

## WARNING!



Mow only in conditions where you have clear visibility in daylight or with adequate artificial lighting. Never mow in darkness or foggy conditions where you cannot clearly see at least 100 yards in front and to the sides of the tractor and mower. Make sure that you can clearly see and identify passersby, steep slopes, ditches, drop-offs, overhead obstructions, power lines, debris and foreign objects. If you are unable to clearly see this type of items discontinue mowing. (SGM-1)

## DANGER!



There are obvious and hidden potential hazards in the operation of this Mower. **REMEMBER!** This machine is often operated in heavy brush and in heavy weeds. The Blades of this Mower can throw objects if shields are not properly installed and maintained. Serious injury or even death may occur unless care is taken to insure the safety of the operator, bystanders, or passersby in the area. Do not operate this machine with anyone in the immediate area. Stop mowing if anyone is within 100 yards of mower. (SGM-2)



## DANGER!



All Safety Shields, Guards and Safety devices including (but not limited to) - the Deflectors, Chain Guards, Steel Guards, Gearbox Shields, PTO integral shields, and Retractable Door Shields should be used and maintained in good working condition. All safety devices should be inspected carefully at least daily for missing or broken components. Missing, broken, or worn items must be replaced at once to reduce the possibility of injury or death from thrown objects, entanglement, or blade contact. (SGM-3)

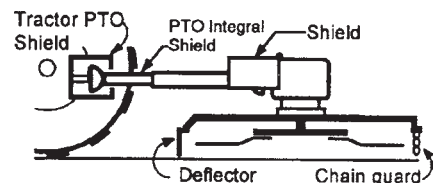

# SAFETY

## DANGER!



The rotating parts of this machine have been designed and tested for rugged use. However, the blades could fail upon impact with heavy, solid objects such as metal guard rails and concrete structures. Such impact could cause the broken objects to be thrown outward at very high velocities. To reduce the possibility of property damage, serious injury, or even death, never allow the cutting blades to contact such obstacles. (SGM-4)

## WARNING!



Extreme care should be taken when operating near loose objects such as gravel, rocks, wire, and other debris. Inspect the area before mowing. Foreign objects should be removed from the site to prevent machine damage and/or bodily injury or even death. Any objects that cannot be removed must be clearly marked and carefully avoided by the operator. Stop mowing immediately if blades strike a foreign object. Repair all damage and make certain rotor or blade carrier is balanced before resuming mowing. (SGM-5)



## WARNING!



Many varied objects, such as wire, cable, rope, or chains, can become entangled in the operating parts of the mower head. These items could then swing outside the housing at greater velocities than the blades. Such a situation is extremely hazardous and could result in serious injury or even death. Inspect the cutting area for such objects before mowing. Remove any like object from the site. Never allow the cutting blades to contact such items. (SGM-6)

## WARNING!



Mow at the speed that you can safely operate and control the tractor and mower. Safe mowing speed depends on terrain condition and grass type, density, and height of cut. Normal ground speed range is from 0 to 5 mph. Use slow mowing speeds when operating on or near steep slopes, ditches, drop-offs, overhead obstructions, power lines, or when debris and foreign objects are to be avoided. (SGM-7)

## WARNING!



Avoid mowing in reverse direction when possible. Check to make sure there are no persons behind the mower and use extreme care when mowing in reverse. Mow only at a slow ground speed where you can safely operate and control the tractor and mower. Never mow an area that you have not inspected and removed debris or foreign material. (SGM-8)

## WARNING!



Do not put hands or feet under mower decks. Blade Contact can result serious injury or even death. Stay away until all motion has stopped and the decks are securely blocked up. (SGM-9)



## DANGER!



Replace bent or broken blade with new blades. NEVER ATTEMPT TO STRAIGHTEN OR WELD ON BLADES SINCE THIS WILL LIKELY CRACK OR OTHERWISE DAMAGE THE BLADE WITH SUBSEQUENT FAILURE AND POSSIBLE SERIOUS INJURY FROM THROWN BLADES. (SGM-10)

# SAFETY

## WARNING!



Do not mow with two machines in the same area except with Cab tractors with the windows closed. (SGM-11)

## DANGER!



Rotary and Flail Mowers are capable under adverse conditions of throwing objects for great distances (100 yards or more) and causing serious injury or death. Follow safety messages carefully. **STOP MOWING IF PASSERSBY ARE WITHIN 100 YARDS UNLESS:**

- Front and Rear Deflectors are installed and in good, working condition;
- Mower Head is running close to and parallel to the ground without exposed Blades;
- Passersby are outside the existing thrown-object zone;
- All areas have been thoroughly inspected and all foreign material such as rocks, cans, glass, and general debris has been removed.



**NOTE:** Where there are grass and weeds high enough to hide debris that could be struck by the blades, the area should be: inspected and large debris removed, mowed at an intermediate height, inspected closely with any remaining debris being removed, and mowed again at desired final height. (SBM-1)



## DANGER!



Use extreme caution when raising the Mower head. Stop the Blades from turning when the Mower Head is raised and passersby are within 100 yards. Raising the Mower head exposes the Cutting Blades which creates a potentially serious hazard and can cause serious injury by objects thrown from the Blades or by contact with the Blades. (SBM-2)

## DANGER!



Be particularly careful in transport. The Mower has raised the center of gravity for the tractor and has increased the possibility of overturn. Turn curves or go up slopes only at low speed and using a gradual turning angle. Slow down on rough or uneven surfaces. (SBM-3)



## WARNING!



Never Leave the mower unattended while the head is in the raised position. The mower could fall causing serious injury to anyone who might inadvertently be under the mower. (SBM-4)



## WARNING!



The rotating parts of this machine continue to rotate even after the Tractor has been turned off. The operator should remain in his seat for 60 seconds after the brake has been set, the PTO disengaged, the tractor turned off, and all evidence of rotation has ceased. (SBM-5)

**“Wait a minute...Save a life!”**

# SAFETY



Relieve hydraulic pressure prior to doing any maintenance or repair work on the Implement. Place the Mower Head on the ground or securely supported on blocks or stands, disengage the PTO, and turn off the engine. Push and pull the control Levers or Joystick several times to relieve pressure prior to starting any maintenance or repair work. (SBM-6)

**DANGER!**



Always keep a careful lookout and use extreme care when working around overhead obstructions. Never allow the Mower head or boom within 10 feet of any power line. When working close to overhead power lines consult your electric company for a safe code of operation. (SBM-7)

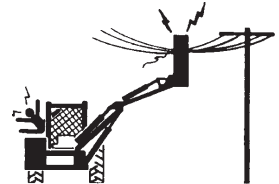

**DANGER!**



When transporting Boom Mower on a truck or trailer, the height or width may exceed legal limits when the boom is in the transport position. Contact with side or overhead structures or power lines can cause property damage or serious injury or death. If necessary lower boom to reduce height and/or remove mowing head to reduce width to the legal limits. (SBM-8)

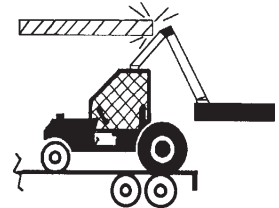

**DANGER!**



Never operate the Tractor and Mower Unit without an OPS (Operators Protective Structure) or Cab to prevent injury from objects thrown from ground or from overhead trimming. Stop mowing if workers or passersby are within 100 yards. (SBM-9)



**DANGER!**



Each Rear Wheel must have a minimum of 1500 pound contact with the surface to prevent lateral instability and possible tip-over which could result in serious bodily injury or even death. Widen the wheel tread and add weights if needed. Refer to the mounting instructions or call Customer Service if you need assistance with Counterweight Procedure. (SBM-11)



**DANGER!**



Always disconnect the wire leads from the mower pump solenoid before performing service on the Tractor or Mower. Use caution when working on the Tractor or Mower. Tractor engine must be stopped before working on Mower or Tractor. The Mower Blades could inadvertently be turned on without warning and cause immediate dismemberment, injury or death. (SBM-12a)

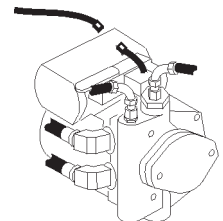

**DANGER!**



The flail cutter shaft is designed for standard rotation (same rotation as the tractor wheels during forward travel). **Never operate the cutter shaft in the reverse rotation.** Operating this mower in reverse rotation may cause objects to be thrown out the front of the mower head.

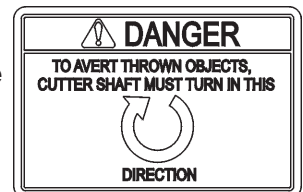



# SAFETY

**WARNING!**



Engine Exhaust, some of its constituents, and certain components contain or emit chemicals known to the state of California to cause cancer and birth or other reproductive harm.

**WARNING!**



Battery posts, terminals and related accessories contain lead and lead compounds, chemicals known to the state of California to cause cancer and birth or other reproductive harm. **Wash hands after handling!**

Tiger mowers use balanced and matched system components for blade carriers, blades, cutter-shafts, knives, knife hangers, rollers, drive-train components and bearings. These parts are made and tested to Tiger specifications. Non-genuine “will fit” parts do not consistently meet these specifications. The use of “will fit” parts may reduce mower performance, void mower warranties and present a safety hazard. Use genuine Tiger mower parts for economy and safety.

SEE YOUR  DEALER

**In addition to the design and configuration of this Implement, including Safety Signs and Safety Equipment, hazard control and accident prevention are dependent upon the awareness, concern, prudence, and proper training of personnel involved in the operation, transport, maintenance, and storage of the machine. Refer also to Safety Messages and operation instruction in each of the appropriate sections of the Tractor and Equipment Manuals. Pay close attention to the Safety Signs affixed to the Tractor and Equipment.** (SG-18)

# SAFETY

## DANGER

FAILING TO FOLLOW SAFETY MESSAGES AND OPERATING INSTRUCTIONS CAN CAUSE SERIOUS BODILY INJURY OR EVEN DEATH TO OPERATOR AND OTHERS IN THE AREA.



1. Study and understand Operator's Manuals, Safety Signs, and Instructional Decals for tractor & flail mower to prevent misuse, abuse, & accidents. Practice before operating mower in a confined area or near passersby.
  - Learn how to stop engine suddenly in an emergency. Be alert for passersby and especially children.
2. Allow no children on or near implement or tractor. Allow no riders on tractor or implement. Falling off can cause serious injury or death from being runover by tractor or mower or contact with Flail Mower Blades.
3. Operate only with tractor having Roll-Over Protective Structure (ROPS) and with seatbelt fastened securely and snugly to prevent injury and possible death from falling off or tractor overturn. Personal Protective Equipment such as Hard Hat, Safety Glasses, Safety Shoes, and Ear Plugs are recommended.
4. Block up or support raised machine and all lifted components securely before putting hands or feet under or working underneath any lifted component to prevent crushing injury or death from sudden dropping or inadvertent operation of controls. Make certain that area is clear before lowering or folding.
5. Before transporting, put Lift Lever in detent or full-lift position. Install Transport Safety Devices securely on folding implements. Slow down when turning and on hillsides.
  - Install \*\*Restrictor in folding circuit to slow down lowering and unfolding if action is faster than is desirable.
6. Make certain that SMV sign, Warning Lights, and Reflectors are clearly visible. Follow local traffic codes.
7. Never operate with Flail Mower or Folding Section raised if passersby, bystanders or traffic are in the area to reduce possibility of injury or death from objects thrown by Blades under Shields or implement structure.
8. Before dismounting, secure flail mower in transport position or lower to ground.
  - Put tractor in park or set brake, disengage PTO, stop engine, remove key, and wait until noise of rotation has ceased to prevent entanglement in rotating parts which may cause injury or death.
  - Never mount or dismount a moving vehicle. Crushing from runover may cause injury or death.

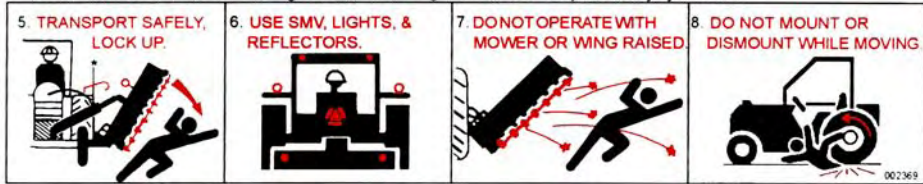

PART NO.  
LOCATION

002369  
HYDRAULIC TANK

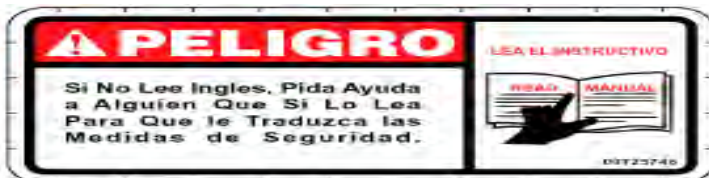

00725746  
INSIDE OF CAB

## DANGER

THROWN OBJECTS



CUTTING BLADES



### KEEP AWAY - ROTATING BLADES

BEING HIT BY THROWN OBJECTS OR CONTACTING ROTATING BLADES CAN CAUSE INJURY OR DEATH.

- Stop mowing if passersby enter the area of thrown objects (See Operator's Manual).
- Use special care if Mower Head or Wing is raised off the ground. (See Manual).
- Operate only if all Guards-Deflectors are in place and in good condition.

00769737

00769737  
MOWER DECK

# SAFETY



PART NO.  
LOCATION

00758194  
MOWER DECK



02962764  
MAIN BOOM, SECONDARY BOOM, MAIN FRAME



02962765  
MAIN FRAME

02965262  
HYDRAULIC TANK

# SAFETY

## **DANGER**

CUTTING BLADES



THROWN OBJECTS



### KEEP AWAY - ROTATING BLADES

BEING HIT BY THROWN OBJECTS OR CONTACTING ROTATING BLADES CAN CAUSE INJURY OR DEATH

- Stop mowing if passersby enter the area of thrown objects. (See Operator's Manual)
- Use special care when Flail or Wing is raised off the ground. (See Oper. Manual)
- Operate only if all Guards-Deflectors are in place and in good condition.

PART NO.  
LOCATION

02967668  
MOWER DECK

02971123  
HYDRAULIC TANK

03200285  
OUTSIDE OF CAB

22645  
INSIDE OF CAB

22839  
MOWER DECK

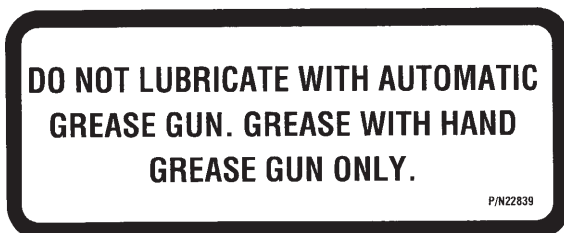
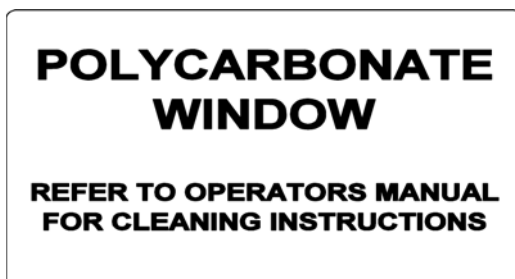

# SAFETY



PART NO.  
LOCATION

22840  
INSIDE OF CAB



24028  
MOWER DECK

25387  
INSIDE OF CAB



10" x 5.5" 31522  
MOWER DECK, MAIN BOOM  
18.25" x 10" 31523  
HYDRAULIC TANK

# SAFETY



PART NO.  
LOCATION

27001  
INSIDE OF CAB

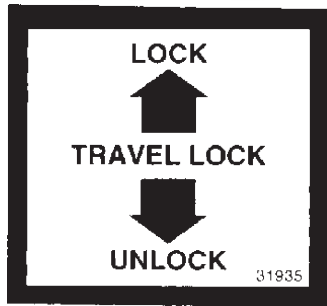

31935  
INSIDE OF CAB

## DANGER

1. EACH REAR WHEEL MUST HAVE A MINIMUM OF 1500 POUNDS CONTACT WITH THE SURFACE TO PREVENT LATERAL INSTABILITY AND POSSIBLE TIP-OVER WITH BODILY INJURY. WIDEN WHEEL TREAD AND ADD WEIGHTS IF NEEDED. SEE MANUAL OR CALL TIGER CUSTOMER SERVICE FOR COUNTERWEIGHT PROCEDURE.
2. TRANSPORT CAREFULLY! SLOW DOWN EVEN MORE ON SLOPES AND WHEN TURNING; NEVER TURN UP A SLOPE SHARPLY OR AT HIGH SPEED; AND USE EXTRA CARE IN ROUGH OR BUMPY AREAS TO PREVENT OVERTURN AND POSSIBLE CRUSHING INJURY OR DEATH. IF YOUR VIEW TO THE REAR IS BLOCKED, IT IS YOUR RESPONSIBILITY TO INSTALL MIRRORS THAT PROVIDE A REAR VIEW TO PREVENT ACCIDENTS FROM BLIND SPOTS.
3. REAR-MOUNTED BOOM MOWERS MOVE CENTER OF GRAVITY TO THE REAR AND REMOVE WEIGHT FROM FRONT WHEELS. ADD FRONT BALLAST UNTIL AT LEAST 20% OF TRACTOR'S WEIGHT IS ON FRONT WHEELS TO PREVENT REARING UP, LOSS OF STEERING CONTROL, AND POSSIBLE INJURY.
4. NEVER OPERATE UNIT WITHOUT AN OPS (OPERATOR PROTECTIVE STRUCTURE) OR CAB TO PREVENT INJURY FROM OBJECTS THROWN FROM GROUND AND OVERHEAD TRIMMING. STOP CUTTING IF ANYONE IS WITHIN 100 YARDS.
5. KEEP THE BOOM AND CUTTERHEAD AT LEAST 10 FEET FROM ELECTRIC LINES AND PIPE LINES TO PREVENT ACCIDENTAL CONTACT AND POSSIBLE SERIOUS INJURY OR EVEN DEATH.
5. WHEN TRANSPORTING BOOM MOWERS ON A TRUCK OR TRAILER, THE HEIGHT OR WIDTH MAY EXCEED LEGAL LIMITS. CONTACT WITH SIDE OR OVERHEAD STRUCTURES OR POWER LINES CAN CAUSE SERIOUS INJURY OR DEATH. LOWER BOOM TO REDUCE HEIGHT AND/OR REMOVE MOWING HEAD TO REDUCE WIDTH TO THE LEGAL LIMITS, IF NEEDED. 32707

32707  
HYDRAULIC TANK



42350  
MOWER DECK

# SAFETY

## ATTENTION

**SERVICE HYDRAULIC SYSTEM  
WITH UNIVERSAL TRACTOR  
HYDRAULIC OIL.**

32708

PART NO.  
LOCATION

32708  
HYDRAULIC TANK

## CAUTION

For your safety and to guarantee optimum product reliability, always use genuine TIGER replacement parts. The use of inferior "will-fit" parts will void warranty of your TIGER implement and may cause premature or catastrophic failure which can result in serious injury or death. If you have any questions concerning the repair parts you are using, contact TIGER, 3301 N. LOUISE AVE., SIOUX FALLS, SD 57107

32709

32709  
INSIDE OF CAB

33224  
MOWER DECK

# Tiger™

33438  
MAIN BOOM

# SAFETY

PART NO.  
LOCATION

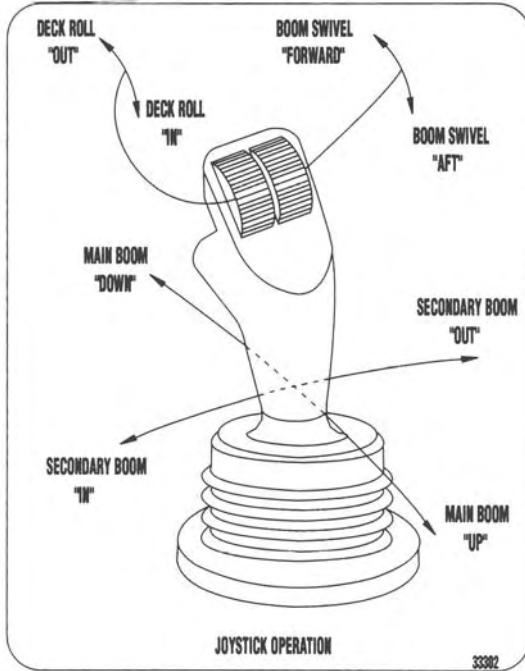

33302  
INSIDE OF CAB

### MOWING SAFETY TIPS

- Read & understand the Operators Manual.
- Wear Your Seat Belt.
- Keep all shields and guards in place.
- Make sure equipment is in proper working condition.
- Never attempt to get off or on a moving tractor.
- Never allow riders on tractor or equipment.
- Only start the tractor from the seat with the key.
- Always inspect the area before mowing. Remove all foreign debris.
- Always keep bystanders and coworkers a minimum of 300 feet away.
- Never allow the mower blades to contact solid objects or foreign material.
- Never approach rotating elements.
- Disengage the PTO, place transmission in "Park", set parking brake, shut off engine, and remove key and wait until all rotating motion has stopped before leaving seat.

Tiger

33743

33743  
INSIDE OF CAB



# SAFETY



PART NO.  
LOCATION  
RED 42399  
REFLECTIVE TAPE  
MOWER DECK

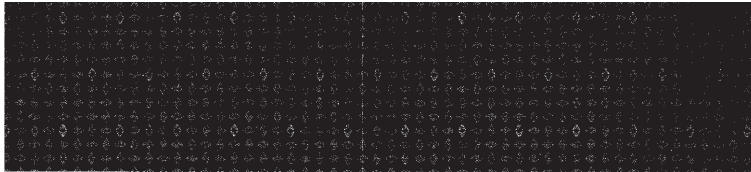

AMBER 42400  
REFLECTIVE TAPE  
MOWER DECK



6T3217  
MOWER DECK



6T3219  
INSIDE OF CAB

6T3220  
FRONT PUMP MOUNT

# SAFETY



PART NO.  
LOCATION

6T3221  
INSIDE OF CAB

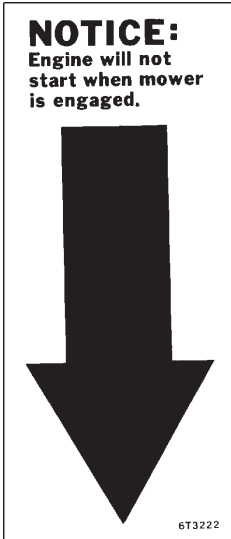

6T3222  
INSIDE OF CAB



6T3224  
MOWER DECK

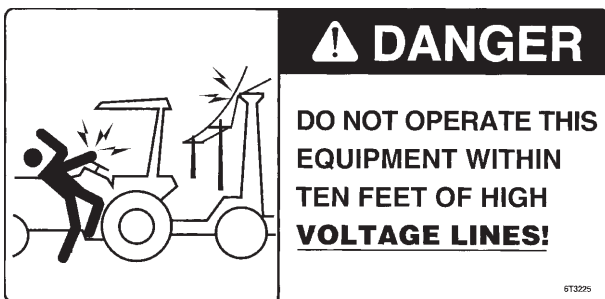

6T3225  
INSIDE OF CAB

# SAFETY

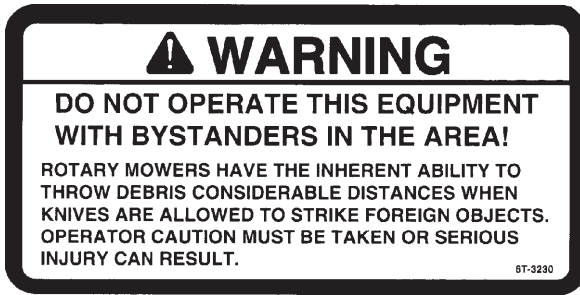

PART NO.  
LOCATION

6T3230  
INSIDE OF CAB



6T3231  
INSIDE OF CAB



6T3233  
HYDRAULIC TANK



6T3234  
INSIDE OF CAB



6T3236  
MOWER DECK

# SAFETY

**⚠ WARNING**

**WHEN CUTTING HEAVY BRUSH,  
BLADE BOLTS SHOULD BE  
INSPECTED HOURLY AND  
RETORQUED TO 600 FT. LBS.**

6T-3237

6T3237

PART NO.  
LOCATION  
6T3237  
INSIDE OF CAB

DOWN ↑ MAIN BOOM ↓ UP	OUT ↑ SECONDARY BOOM ↓ IN	OUT ↑ DECK ROLL ↓ IN	FORWARD ↑ SWING ↓ BACKWARD <small>6T-3241</small>
-----------------------------------	---------------------------------------	----------------------------------	---

6T3241

6T3241  
INSIDE OF CAB

DOWN ↑ MAIN BOOM ↓ UP	OUT ↑ SECONDARY BOOM ↓ IN	OUT ↑ DECK ROLL ↓ IN	FORWARD ↑ SWING ↓ BACKWARD	CLOSE ↑ SHIELD ↓ OPEN <small>34206</small>
-----------------------------------	---------------------------------------	----------------------------------	--	--

34206  
INSIDE OF CAB

<p style="text-align: center;"><b>⚠ WARNING</b></p> <p style="font-size: x-small;">IT IS RECOMMENDED THAT THE BOLT AND LOCK NUT BE REPLACED WHENEVER BLADES ARE REPLACED. REPLACE THESE ANY TIME THEY ARE DAMAGED OR WORN AS FAILURE TO DO SO CAN LEAD TO BLADES COMING OFF CAUSING SERIOUS INJURY OR DEATH.</p>	<p style="text-align: center;"><b>IMPORTANT</b></p> <ul style="list-style-type: none"> <li>• WHEN REPLACING BLADES, IT IS RECOMMENDED THAT ALL BLADES BE REPLACED FOR PROPER BALANCE TO AVOID EXCESSIVE VIBRATIONS WHICH CAN DAMAGE SPINDLE ASSEMBLY.</li> <li>• SEE YOUR OPERATOR'S MANUAL FOR PROPER INSTALLATION INSTRUCTIONS.</li> </ul> <p style="text-align: right; font-size: x-small;"><small>6T-3243</small></p>
--	---

6T3243  
INSIDE OF CAB

**GREASING INSTRUCTIONS**  
CUTTER SHAFT BEARING

GREASE EVERY 8 HRS. OR DAILY

NOTE: If unusual environmental conditions exist-extreme temperatures, moisture, or contaminants-more frequent lubrication is required.

6T3249A

6T3249A  
MOWER DECK

**GREASING INSTRUCTIONS**  
GROUND ROLLER BEARING

GREASE EVERY 8 HRS. OR DAILY

NOTE: If unusual environmental conditions exist-extreme temperatures, moisture, or contaminants-more frequent lubrication is required.

6T3261

6T3261  
MOWER DECK

# SAFETY



TB1011  
MOWER DECK



**Tiger Corporation**

800-843-6849  
www.tiger-mowers.com

Description	Application	General Specification	Recommended Lubricant
Tractor Hydraulics	Reservoir	JD-20C	Mobilfluid® 424
Mower Hydraulics Cold Temperatures 0°F Start-up  Normal Temperatures 10°F Start-up Normal Temperatures 15°F Start-up High Operating Temperatures Above 90°F Ambient	Reservoir	ISO 46 Anti-Wear/ Low Temp JD-20C ISO 46 Anti-Wear ISO 100 Anti-Wear	Mobil DTE® 15M  Mobilfluid® 424 Mobil DTE® 25 Mobil DTE® 18M
Flail Rear Gearbox	Reservoir	PAO Synthetic Extreme Pressure Gear Lube	Mobilube SHC® 75W-90, Mobil 1 Synthetic Gear Lubricant
Cutter Shaft and Ground Roller Shaft (Flail)	Grease Gun	Lithium Complex, NLGI 2 ISO 320	Mobilgrease® CM-S
Drive Shaft Coupler (Rotary and Flail)	Grease Gun	Lithium Complex, NLGI 2 ISO 320	Mobilgrease® CM-S
Boom Swivel, Boom Cylinder Pivots (Rotary and Flail Boom Type)	Grease Gun	Lithium Complex, NLGI 2 ISO 320	Mobilgrease® CM-S
Deck Boom Pivot & Deck Stop Adjustment (Rotary and Flail)	Grease Gun	Lithium Complex, NLGI 2 ISO 320	Mobilgrease® CM-S
Deck Spindle (Rotary)	Grease Gun	Tiger Spindle Lubricant	Mobilith SHC 220

**For Mobil product information, availability, or technical information, call 1-800-662-4525.**

Tiger PN 34852

34852  
HYDRAULIC TANK

# SAFETY

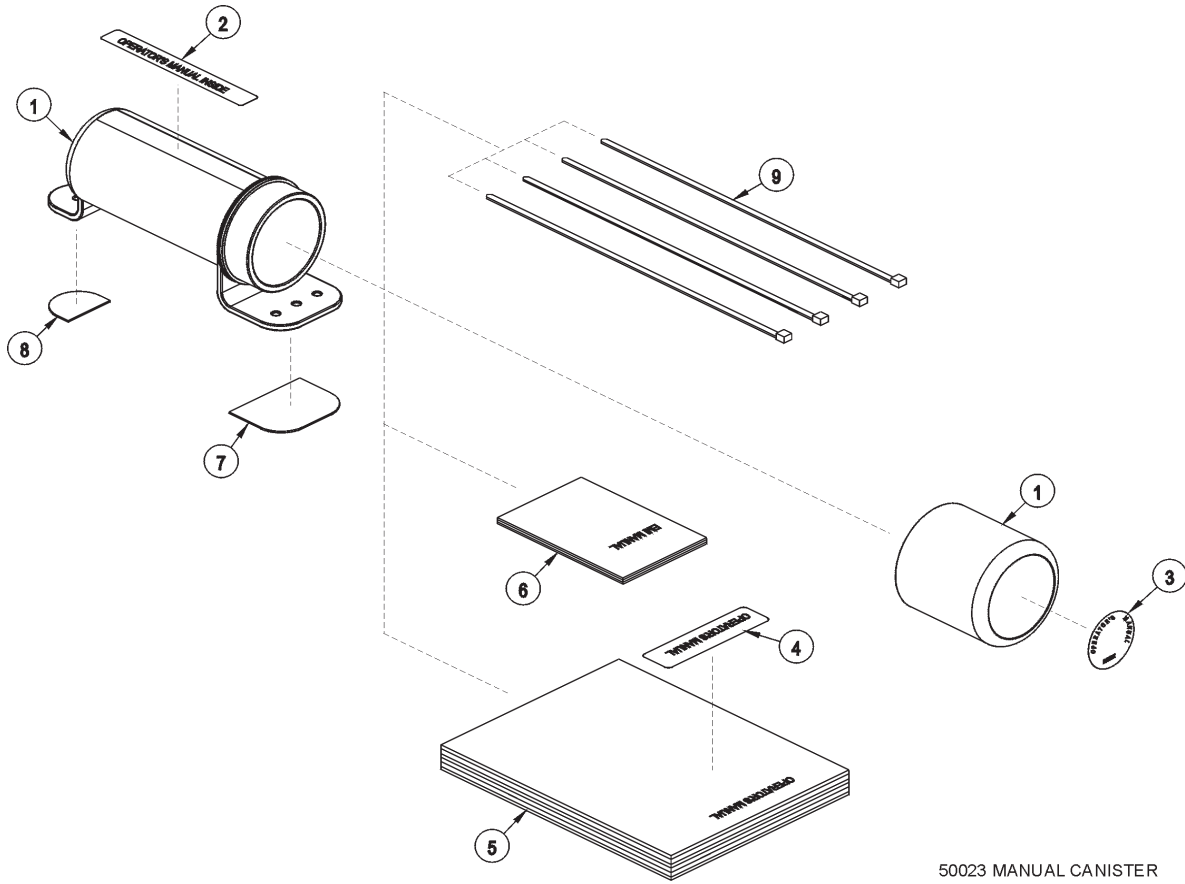

50023 MANUAL CANISTER

ITEM	PART NO.	QTY.	DESCRIPTION
	<b>50023</b>	<b>AVAIL</b>	<b>MANUAL CANISTER COMPLETE</b>
1	00776031	1	ROUND MANUAL CANISTER
	33997	1	DECAL, SHEET, MANUAL CANISTER
2		*	DECAL
3		*	DECAL
4		*	DECAL
5	*	AVAIL	SPECIFIC PRODUCT MANUAL
6	33753	1	E M I SAFETY MANUAL
7	34296	1	FRONT ADHESIVE PAD
8	34297	1	REAR ADHESIVE PAD
9	6T1823	4	ZIPTIE 14" LONG

**NOTE:**

The manual canister can be bolted, zip tied or adhered to a variety of surfaces. Locate a protected area within the view of the operator. Then select an installation method and attach the canister. **CAUTION - AVOID DRILLING HOLES INTO UNKNOWN AREAS**, wires and other parts may be located behind these areas. When adhering the canister to a surface, thoroughly clean that surface before installing the canister.

# SAFETY

## FEDERAL LAWS AND REGULATIONS

This section is intended to explain in broad terms the concept and effect of federal laws and regulations concerning employer and employee equipment operators. This section is not intended as a legal interpretation of the law and should not be considered as such.

### **Employer-Employee Operator Regulations**

U.S. Public Law 91-596 (The Williams-Steiger Occupational and Health Act of 1970) OSHA

#### **This Act Seeks:**

“...to assure so far as possible every working man and woman in the nation safe and healthful working conditions and to preserve our human resources...”

#### **DUTIES**

Sec. 5 (a) Each employer-

(1) shall furnish to each of his employees employment and a place of employment which are free from recognized hazards that are causing or are likely to cause death or serious physical harm to his employees;

(2) shall comply with occupational safety and health standards promulgated under this Act.

(b) Each employee shall comply with occupational safety and health standards and all rules, regulations and orders issued pursuant to this Act which are applicable to his own actions and conduct.

#### **OSHA Regulations**

OSHA regulations state in part: “At the time of initial assignment and at least annually thereafter, the employer shall instruct every employee in the safe operation and servicing of all equipment with which the employee is, or will be involved.”

#### **Employer Responsibilities:**

To ensure employee safety during Tractor and Implement operation, it is the employer’s responsibility to:

1. Train the employee in the proper and safe operation of the Tractor and Implement.
2. Require that the employee read and fully understand the Tractor and Implement Operator’s manual.
3. Permit only qualified and properly trained employees to operate the Tractor and Implement.
4. Maintain the Tractor and Implement in a safe operational condition and maintain all shields and guards on the equipment.
5. Ensure the Tractor is equipped with a functional ROPS and seat belt and require that the employee operator securely fasten the safety belt and operate with the ROPS in the raised position at all times.
6. Forbid the employee operator to carry additional riders on the Tractor or Implement.
7. Provide the required tools to maintain the Tractor and Implement in a good safe working condition and provide the necessary support devices to secure the equipment safely while performing repairs and service.

#### **Child Labor Under 16 Years of Age**

Some regulations specify that no one under the age of 16 may operate power machinery. It is your responsibility to know what these regulations are in your own area or situation. (Refer to U.S. Dept. of Labor, Employment Standard Administration, Wage & Home Division, Child Labor Bulletin #102.)

# SAFETY



# ASSEMBLY SECTION

# ASSEMBLY

**Before attempting to mount your Tiger mower, it is important to read and understand all of the safety messages in the Safety Section of this manual.**

Check complete shipment list against the packing list to make sure there are no shortages. Make certain the tractor model is the appropriate one for the mower received!



Always use a floor jack, hoist or fork lift to lift and raise heavy parts.

Read and understand the entire Assembly Section instructions before attempting to mount your Tiger mower. Refer to the Parts Section of this manual for detailed illustrations to locate all parts. (ASM-C-0001)

## TRACTOR PREPARATION

- A. Remove right and left hand steps.
- B. Disconnect battery cables from both batteries.
- C. Remove engine side panels, or raise hood to access front pulley.
- D. Remove plugs from tractor casting where mainframe and pump mount will be attached.
- E. Remove any front weights and weight supports.
- F. Raise the tractor onto jack-stands and remove the right and left rear wheels.

(ASM-JD-0001)

## MAINFRAME INSTALLATION

With an overhead hoist and / or jack-stands, raise one side of the frame up to the correctly matching mounting holes. Install capscrews and other hardware to secure the sides of the mainframe to the tractor casting, as shown on the tractor mount kit page in the Parts Section. **DO NOT** tighten at this time. Remove the capscrews one at a time and apply a thread locking agent. Reinsert the capscrews and tighten / torque to values noted in the torque chart located in the Maintenance Section of this manual. (ASM-C-0003)

## CRANKSHAFT ADAPTER

For JD6xxxD tractors with a front pump mount, install the John Deere pulley kit P/N: LVB24989 and follow the instructions. (ASM-JD-0250)

## ADJUSTING REAR WHEELS

Raise rear of tractor onto jack-stands. **Follow the instructions in the tractor owner's manual for adjusting tires and rims.** The back wheels **MUST** be adjusted to the widest setting. **NOTE:** This may require switching the wheels to opposite sides of tractor. Also take note of any width restrictions when transporting by trailer. (For ease of installation, it is best to leave the rear wheels removed during installation of the mower.) (ASM-B-0001)



# ASSEMBLY

## DRIVESHAFT AND FRONT PUMP MOUNTING

Install driveshaft into the crankshaft adapter.

Slide splined driveshaft coupler onto the pump driveshaft. Install the pump onto the mounting bracket. **NOTE:** the pump is offset to one direction and the pump should be installed with the offset side on top. Install hardware for securing pump to the pump mount, **DO NOT** tighten.

Install pump and align so that splined coupling can be moved (**FREE PLAY**) back and forth by hand. Rotate coupler and check free play every 1/4 turn. Tighten pump mounting bolts in succession, rechecking for spline coupling free play. Remove the pump mounting bracket bolts one at a time and apply a thread locking agent. Tighten these bolts in succession, again checking for free play in the driveshaft. After all bolts are torqued, the end play on the driveshaft should be 1/16" to 1/8", and coupler should move freely with hand pressure. If end play is less than 1/16", grind the end of the shaft to achieve the proper end play. If there is more than 1/4" of end play, return the shaft with specifications for a longer shaft.

**CAUTION: DO NOT START THE TRACTOR UNTIL ALL HOSES ARE ATTACHED, TANK IS FILLED WITH PROPER OIL AND BALL VALVES ARE OPEN! STARTING AT THIS TIME WILL CAUSE SERIOUS DAMAGE TO THE PUMP.** (ASM-C-0091)

## POLYCARBONATE SAFETY WINDOW

**NOTE:** Installing a boom mower requires that all right side windows be replaced or shielded by a lexan safety window. In most cases this should be done before mounting the mainframe. Carefully remove the existing right side cab windows, to be replaced with the matching polycarbonate windows provided.

Clean all of the surfaces around the window opening, once the right side windows are removed. Peel back the protective paper from the area around the window that will contact the window frame. Apply a bead of urethane window adhesive, supplied in kit, around the window opening. Carefully position the new window into position. Fill the remainder of the gap around the window with the adhesive to finish. Be sure to follow the instructions on the adhesive label when installing window.

Next, install the upper and lower door hinges along with the existing cab door hinges. To do this, you will remove the existing hinge hardware and install the existing hardware on the polycarbonate as shown in the Parts Section. Set the safety screen assembly on the hinges and attach the door to the tractor frame. Install the brackets with the hardware shown in the Parts Section. Assemble the rod with the vibration isolator and nuts and attach them to the brackets. Adjust the vibration isolator on the upper and lower brackets to achieve a good fit with the window. (ASM-JD-0061)

## MAINFRAME INSTALLATION

With an overhead hoist and / or jack-stands, raise one side of the frame up to the correctly matching mounting holes. Install capscrews and other hardware to secure the sides of the mainframe to the tractor casting, as shown on the tractor mount kit page in the Parts Section. **DO NOT** tighten at this time. Remove the capscrews one at a time and apply a thread locking agent. Reinsert the capscrews and tighten / torque to values noted in the torque chart located in the Maintenance Section of this manual. (ASM-C-0003)



# ASSEMBLY

## SWITCHBOX WIRING

Cover all wires with plastic wire wrap provided. Route the green wires along switchbox bracket and cab frame to the steering wheel console. Route the rest of the wires along the base of the right hand console and up to the rubber boot in the bottom right corner in the rear window of the cab. The red and black wires will be connected to the auxillary power plug in the back of the cab. After all wiring is complete, secure all wires to the console with zip ties and push mounts. Take up most of the slack so the wires are out of the way and tighten the zip ties.

With the panel under the steering wheel removed to access the wires, locate the brown wire and verify that this is the neutral safety wire with a test light or meter. Then cut the brown wire and connect a green wire from the switchbox to each end of the brown wire as shown in the wiring diagram. Cut a small hole for the green wires and the wire wrap to fit through and replace the console.

The red and black wires access power for the switchbox through a John Deere auxillary power plug in the rear of the cab.

**NOTE: The RED wire from the JD power plug should not be used because it is ALWAYS "Hot". +12 VOLTS ELECTRICAL POWER MUST BE TAKEN FROM A SOURCE LOCATION WHERE IT IS LIVE ONLY WHEN THE IGNITION SWITCH IS IN THE "ON" POSITION. THE RED WIRE MUST BE FUSED AT THE SOURCE LOCATION WITH A CLOSED END CONNECTOR (# 34538).**

Connect the red wire from the switchbox to the orange wire from the JD power plug. Connect the black wire from the switchbox to the black wire from the JD power plug.

Two sets of wires have Metri-Pak ends on them. The white and black wires plug into the brake valve. The orange and black wires plug into the travel lock.

Cut a crosshair pattern in the rubber boot in the right bottom corner of the rear window. The wires can be routed through and the rubber falls back into position. The hole should only be large enough for the wires to go through easily.

Route the Metri-Pak wires from the window boot to their location on the unit. Coil the excess wire and secure it to the tractor frame with zip ties to eliminate vibration and rubbing. (ASM-JD-0078)

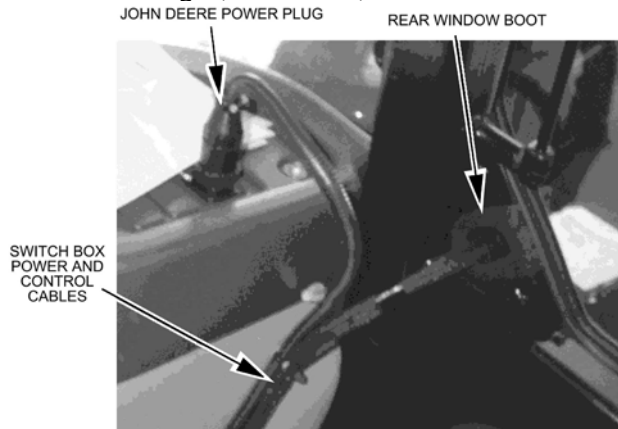

34538 - CLOSED END CONNECTOR



**NOTE:** When cutting or drilling a hole, be sure not to damage existing wires running behind panels.



# ASSEMBLY

## WEATHER-PACK / METRI-PACK ASSEMBLY

These instructions apply to both Weather-Pack and Metri-Pack connectors.

**NOTE: Use the specific tool for the type of connector you are assembling.**

(ASM-C-0009)

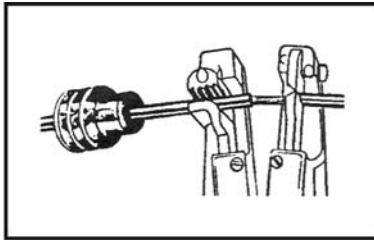

1. Apply seal to cable, before stripping insulation.

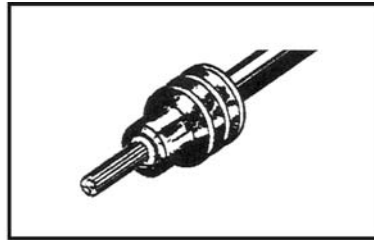

2. Align seal with cable insulation.

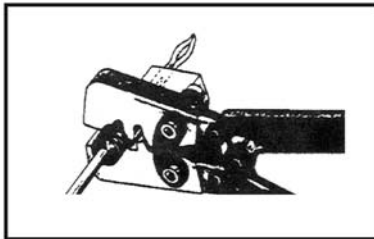

3. Put terminal in crimping tool, then position wire and seal in place.

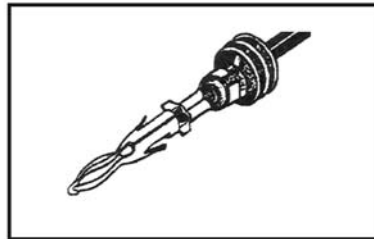

4. Crimp and visually inspect for a good crimp before installing in connector body.

## MANUAL SWITCHBOX MOUNTING

The switchbox is to be secured to the operator's side of the control handles, or valve stand. Refer to the Parts Section for assembly and components needed.

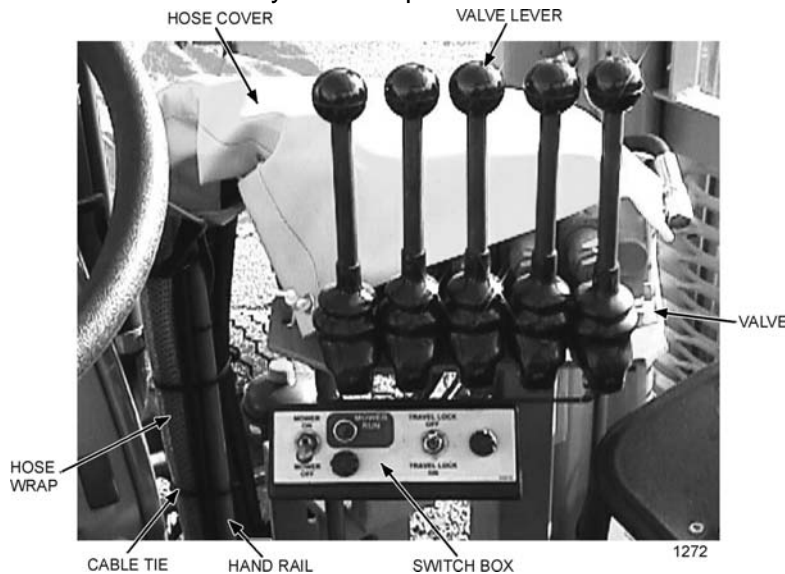

(ASM-C-0053)



# ASSEMBLY

## TRACTOR PLUMBING

Remove the stock pressure line to the remote valve. It will be necessary to temporarily remove other hoses and tubes that block access to connect the hoses. Install the pressure hose to the tractor pressure port. Install hose #06500783 from the power beyond port of the lift valve to the tractor SCV valve. Install pressure hose #06500782 from the tractor pressure on the side of the tractor to the upper port on the lift valve inlet. Install return hose #06500782 from lower port on lift valve inlet to the return filter on the tractor. See the Parts Section for parts used.

*(ASM-JD-0242 6xxxD)*

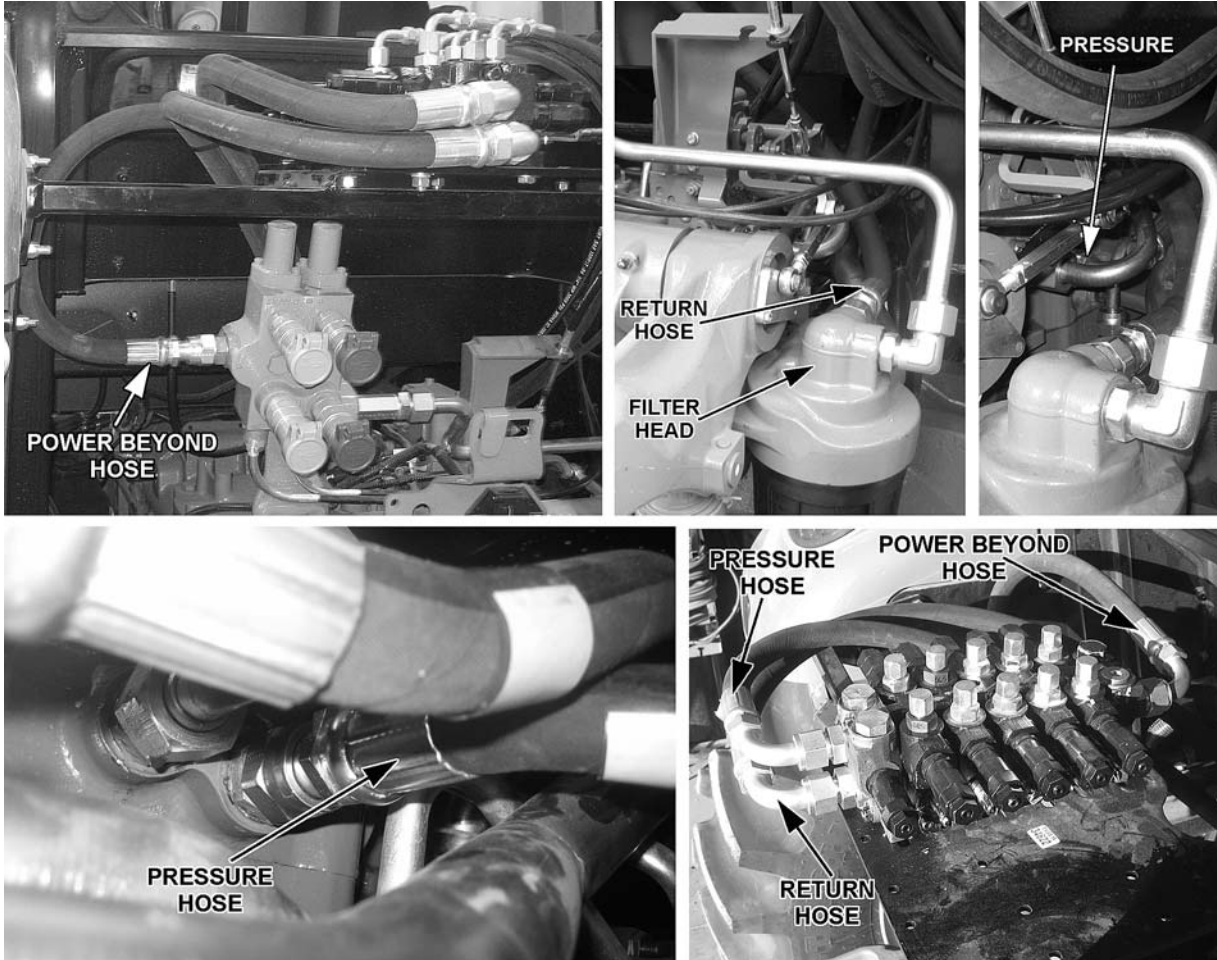

# ASSEMBLY

## MANUAL LIFT VALVE PORTS

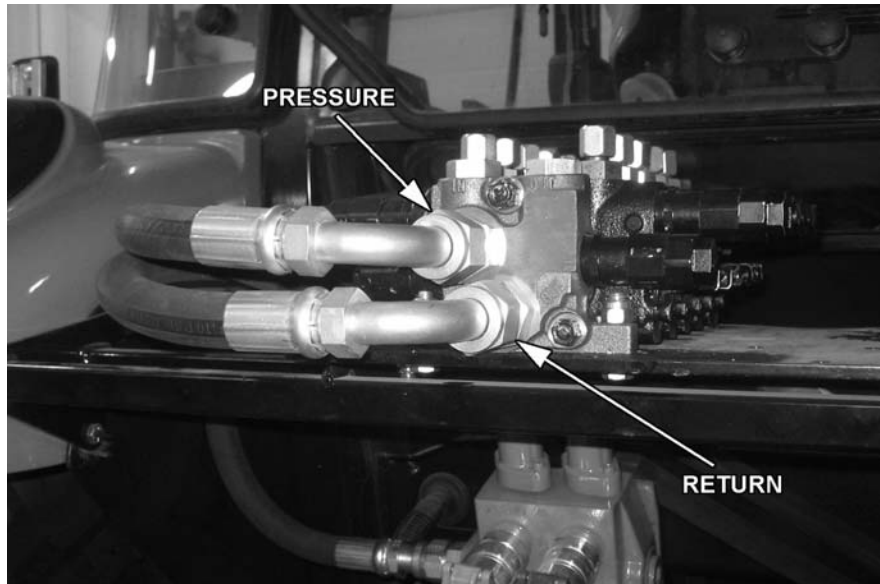

(ASM-C-0102 JD6xxxD)

## VALVE MOUNTING

Attach the rear valve mounting bracket to the fender of the tractor by removing the two rear bolts on the left fender and the two rear bolts on the right fender. See illustration below. Drill the square holes in the fenders to accept 3/8" capscrews. Use the hardware noted in the Parts Section to attach the valve mounting bracket to the tractor.

Next, attach the valve mounting plate to the mounting bracket. Align the holes on the plate to the holes on the bracket. Use the hardware shown in the Parts Section to attach the plate to the valve mounting bracket. Finally, place the valve on the valve mounting plate as shown in the Parts Section. Align the holes on the valve assembly to the holes in the plate. Use the hardware provided to secure the valve to the plate. Refer to the Parts Section for the placement of the valve and the hardware used. **Please handle the lift valve with care. It is extremely heavy and contains small parts.** (ASM-JD-0065)

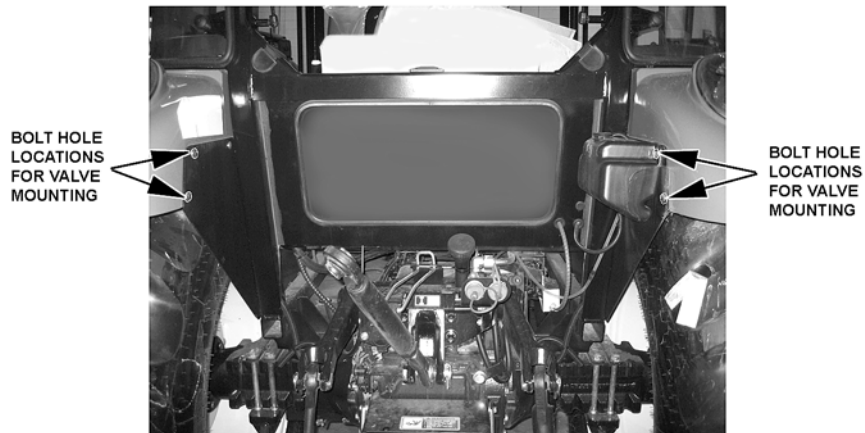

# ASSEMBLY

## HOSE AND WIRE ROUTING

Attach two clamps to the right rear wheel well for proper hose/wire routing. Drill one hole for each clamp. Use the lower rear corner of the wheel well as an origin for measuring. The holes should be 10mm or 3/8" reamed to accept 3/8" hardware.

Measure along the back edge of the wheel well 10-1/2" from the origin. Use a square to measure 2-1/2" up, from the last mark. Refer to the image below to see the first hole.

The second hole should run parallel to the bottom edge of the wheel well. Mark the hole 22" from the origin and 3-1/2" from the bottom edge. Use the images below for reference.

**NOTE: DO NOT CUT INTO TUBES / HOSES / WIRES WHEN DRILLING THROUGH METAL OR PLASTIC!** (ASM-JD-0068)

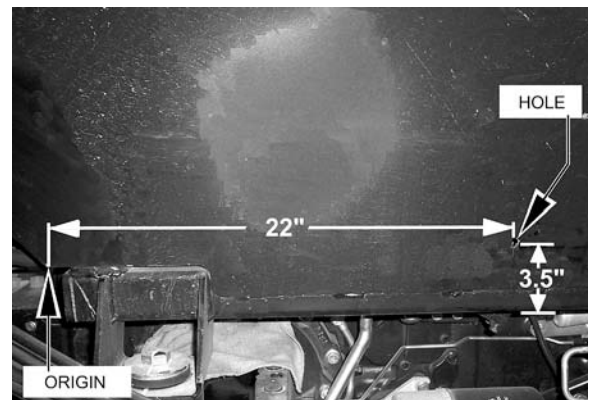
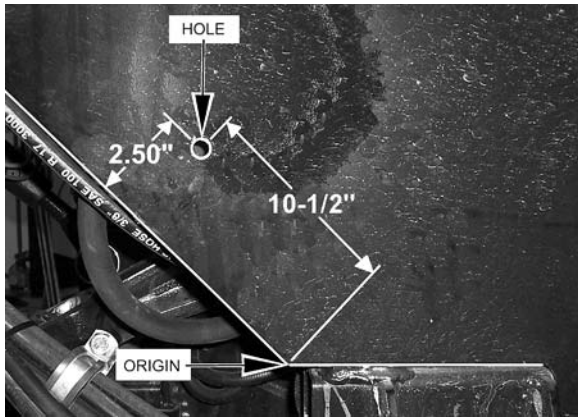

Place as many hoses in the clamp as will fit without compromising pressure. Then secure the (2) HOSE CLAMP (06520013) to the holes drilled with (1 EACH) CAPSCREW, 3/8 X 1 NC (21630) and (1 EACH) NYLOCK NUT, 3/8 NC (21627). The hoses that don't fit into the clamp are to be secured to the others with zip ties. For protection of hoses in contact with metal edges, wrap hoses with split hose sections and fasten with hose clamps or zip ties as needed.

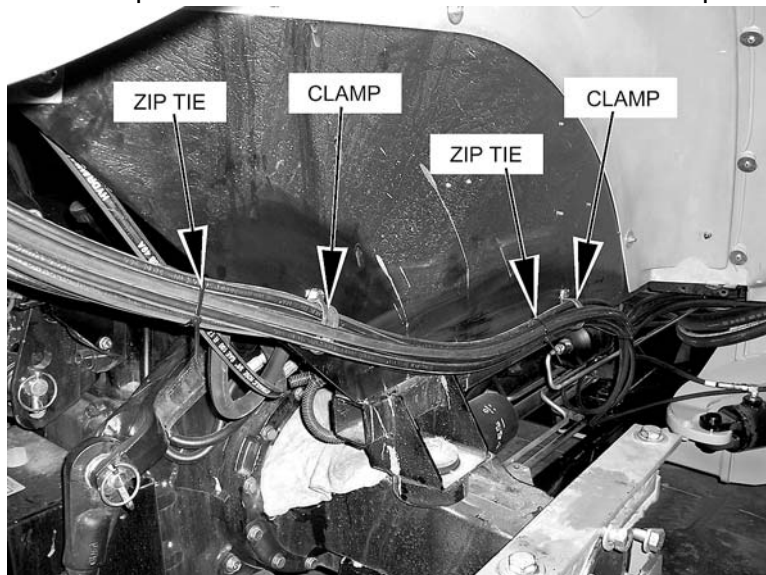



# ASSEMBLY

## CABLE CONTROL LEVER STAND

Place the cable control bracket on the floor so that the bracket is 4" from the front window. Also the outer rear corner (heel) of the bracket is 5" from the edge of the door. The middle corner of the bracket should be 2" from the edge of the door. See image below. Be sure that the location of the stand will allow the operation of all control levers in the tractor and that the door will not strike the stand when shut. Double check under the cab for cables and wires that may be cut when drilling. And before drilling double check location of the stand for proper placement of holes. Drill 3 holes to match control bracket and secure with capscrews and nylock nuts noted in Parts Section.

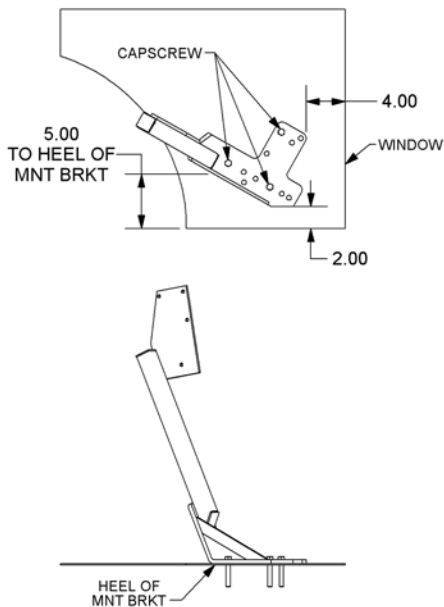

The rubber boot under the rear window can be cut in a crosshair pattern and, if necessary, the bottom cut through to allow it to slip over the cables and back into position. These cables will be routed to the lift valve mounted on the valve mounting plate, and should not have any sharp bends or kinks in them. Secure cables with zip ties and apply RTV sealer in and around individual cables, inside and outside of the cab for a water tight seal. Do not allow excess cable to hang unsecured on the outside of the cab. (ASM-JD-0239).



# ASSEMBLY

## \*NOTE ON HUSCO CONTROL VALVES\*

Manual, cable controlled (Husco control valve) boom mowers require check valves with integral restricting orifice (#06502036) installed in the control valve work ports that are connected to the gland ends of the main and secondary boom cylinders. This check valve allows oil to free flow into the gland end of the main and secondary boom cylinders, but restricts flow out of the cylinder, thereby providing proper boom control. This check valve, #06502036 (Vendor #1968R-.063) is similar in appearance to hose adapter #33271 and Adapter #34396, with .06 orifice. These components can be identified as follows, and are to be installed per Parts Section for the lift valve. (ASM-HUSCO-0001)

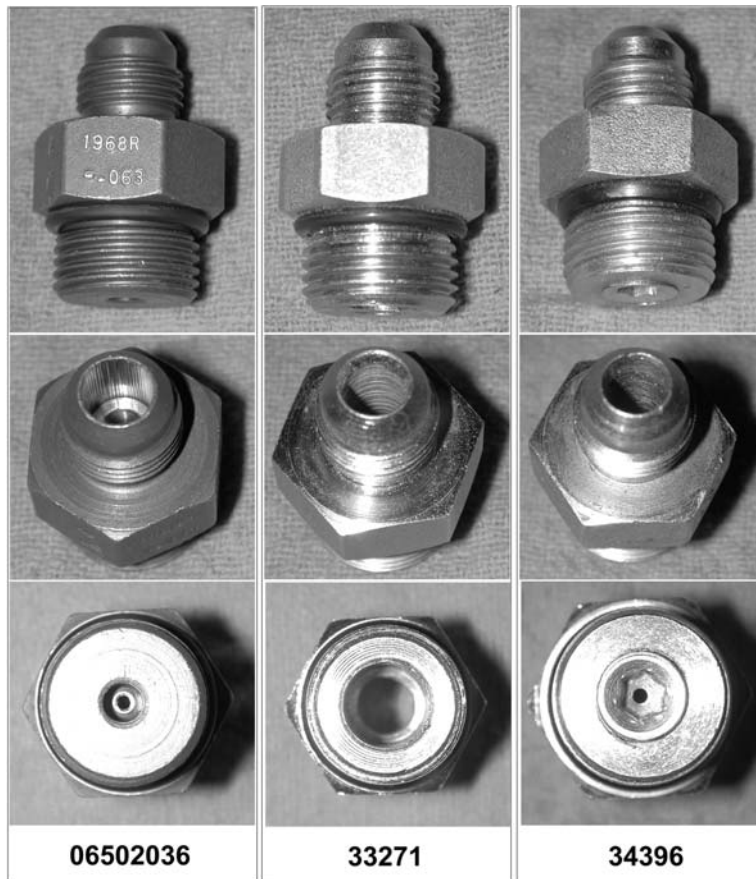

# ASSEMBLY

## ELECTRONIC LIFT VALVE PORTS

(ASM-C-0089)

### DANFOSS VALVE

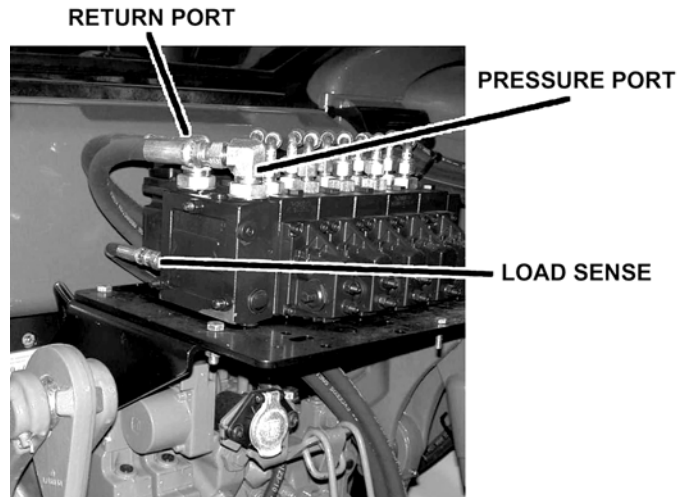

### VALVE MOUNTING

Attach the rear valve mounting bracket to the fender of the tractor by removing the two rear bolts on the left fender and the two rear bolts on the right fender. See illustration below. Drill the square holes in the fenders to accept 3/8" capscrews. Use the hardware noted in the Parts Section to attach the valve mounting bracket to the tractor.

Next, attach the valve mounting plate to the mounting bracket. Align the holes on the plate to the holes on the bracket. Use the hardware shown in the Parts Section to attach the plate to the valve mounting bracket. Finally, place the valve on the valve mounting plate as shown in the Parts Section. Align the holes on the valve assembly to the holes in the plate. Use the hardware provided to secure the valve to the plate. Refer to the Parts Section for the placement of the valve and the hardware used. **Please handle the lift valve with care. It is extremely heavy and contains small parts.** (ASM-JD-0065)

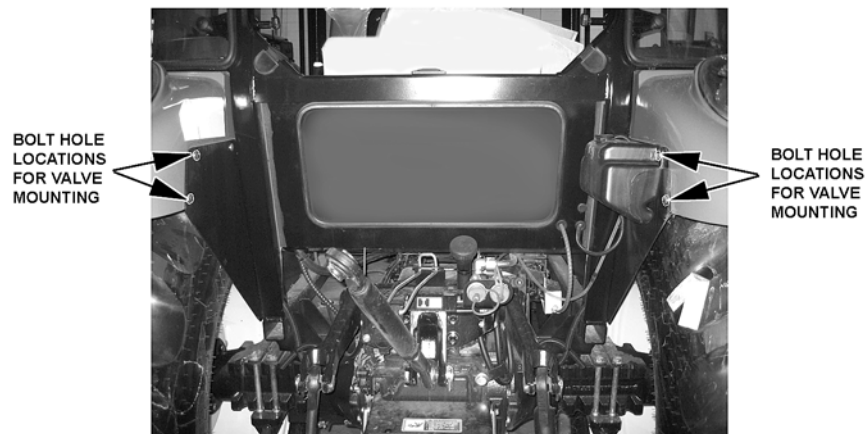

# ASSEMBLY

## JOYSTICK CONTROL MOUNTING

The joystick is mounted to the right hand center cab post. Find the two existing bolts above the area where the post bumps out. See the image below. Mount the joystick mounting bracket to the cab post with hardware provided. Assemble the parts as shown in the Parts Section. When operating the joystick, make sure it is positioned where the rest of the controls are fully operational. (ASM-JD-0075)

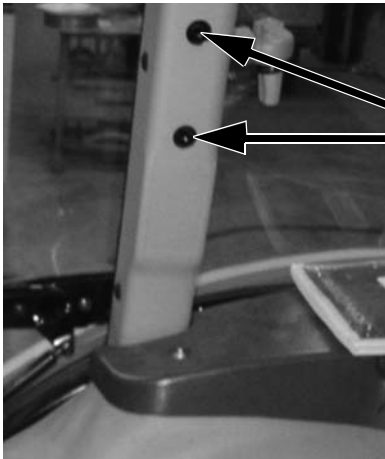

CAB POST  
BOLTS



## JOYSTICK SWITCHBOX MOUNTING

Locate the right side front cross member of the cab frame. Clamp the switchbox mounting brackets to the cross member. See illustration below. Mount the brackets and switchbox using the hardware supplied, as noted in the Parts Section. (ASM-JD-0020)

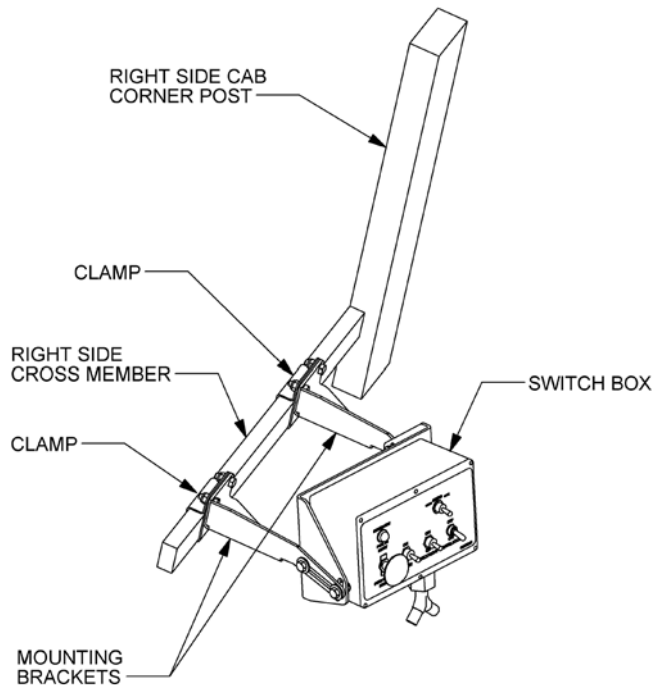

# ASSEMBLY

## BOOM JOYSTICK CONTROL CALIBRATION

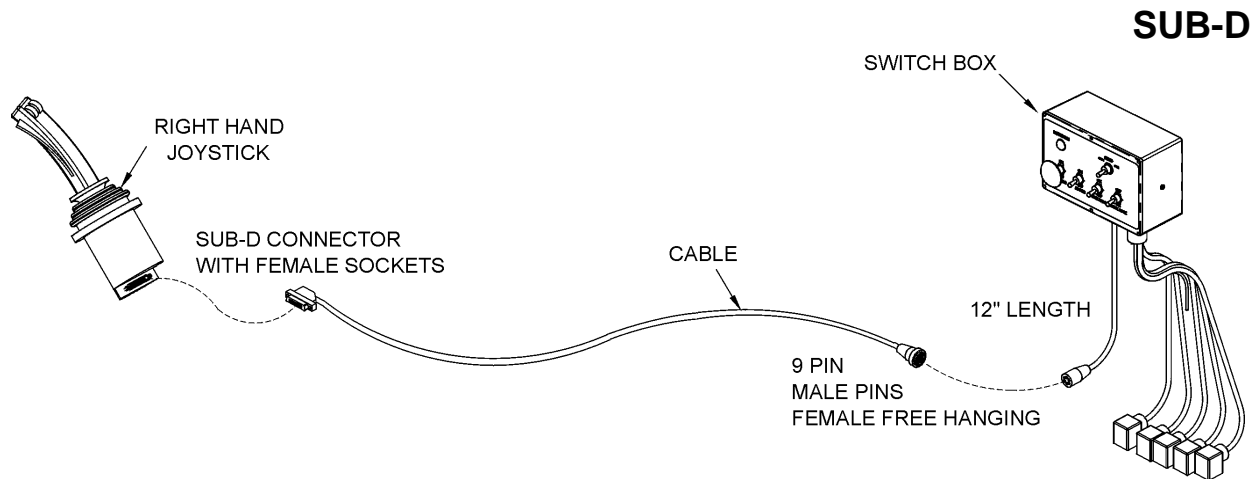

This Electronic control valve is equipped with high-resolution actuators on Boom, Side Shift, Deck Roll, and Boom Swivel functions. These actuators have active fault monitoring. The Deck Shield section does not have active fault monitoring. The joystick provides a ratio-metric voltage signal. The neutral signal voltage is half or 50% of tractor supply voltage. A 25% signal voltage will shift the valve spool to full A-Port, and 75% signal voltage will shift the spool to full B-Port in the Boom, Side Shift, and Boom Swivel valve sections. On the Deck Roll function a 34% signal voltage will shift the valve spool to full A-Port and a 68% signal voltage will shift the spool to full B-port. If an actuator with active fault monitoring receives a signal from the joystick that is less than 15% or greater than 85% of supply voltage the actuator will fault out and shut down. Also, if there is an internal failure in the actuator or if the spool position is greater than that specified by the signal voltage from the joystick, the actuator will “fault out” and shut down. An active fault condition causes the actuator to drive the spool to neutral, shut down, and activate a red LED on the top of the actuator. The active fault can be canceled by simply cycling the Master Switch OFF and then ON, which resets the fault monitoring, and causes the LED on top of the actuator be green again.



The joystick control is equipped with signal adaption potentiometers.

These provide the capability to individually adjust the oil flow to each boom function. It is important that the boom functions do not travel too fast. Excessive boom speed can reduce the stability of the unit and decrease operator control.

Note: Use a Phillips screwdriver and be sure to adjust the screws carefully! DO NOT turn the potentiometers beyond their stopping point, potentiometers are very delicate! Turning the “A” or “B” port potentiometers clockwise increases the oil flow to increase the boom function speed, and turning them counterclockwise decreases the oil flow to decrease the boom function speed. See the graphic on the next few pages for help in adjusting.



# ASSEMBLY

## BOOM JOYSTICK CONTROL CALIBRATION (CONTINUED)

Run tractor at normal operating RPM to adjust the settings as follows.

### **Set the dead band compensation potentiometer first.**

Set the dead band compensation potentiometer at 50%, or halfway between full clockwise and full counter-clockwise.

### **Setting Signal Adaptation Potentiometers:**

Disconnect the Deutsch connectors from the actuators of the valve. Use a Volt/Ohm meter to measure signal voltage and adjust the signal adaptation potentiometers as needed. Pin #4 is tractor supply voltage. Pin #1 is signal voltage from the joystick, and pin #3 is ground. First, measure supply voltage between pins 4 and 3. Then measure signal voltage between pins 1 and 3 while indexing the joystick function fully in both the "A" and "B" port direction. Divide the signal voltage by the supply voltage to get signal voltage as a % of supply voltage. This percentage should not be less than 25% or greater than 75% for the Boom, Side Shift or Boom Swivel function. This percentage should not be less than 30% or greater than 62% for the Deck Roll function. Note these initial settings for the Deck Roll function should prevent the spool from shifting into float. *After making this first adjustment to deck roll if the spool still goes into float, adjust the "B" port screw additionally counterclockwise.*

Reconnect Deutsch connectors on control cables to actuators on Electronic valve. Run tractor until hydraulic system is at operating temperature. Now refine the adjustments of the signal adaptation potentiometers for both "A" and "B" ports for all proportional functions to achieve the following function times. Note: turning potentiometer clockwise increases the flow or the function speed, and turning them counter-clockwise decreases the flow or the function speed. Note, if during this procedure the trim potentiometer is set to full counterclockwise but the function is still too fast, use the mechanical stops at the manual actuator end of the valve section to further limit flow. Turn limit screw in or clockwise to limit flow. The upper limit screw limits flow to "B-port", and the lower limit screw limits flow to A-port. However DO NOT adjust the limit screw on B-port of deck roll function. Limiting B-port will prevent float function.



# ASSEMBLY

## BOOM JOYSTICK CONTROL CALIBRATION (CONTINUED)

**BOOM:** "A" Port, Boom Up: 7-9 Seconds

*(Note: Roll deck to be level with ground, and lower boom until deck is on ground. Now index boom "up" function and determine the time required for boom to rise completely.)*

"B" Port, Boom Down: 6-8 Seconds

*(Note: Roll deck to be level with ground, and raise the boom to "full up". Then index the boom "down" function to determine the amount of time required for the deck to contact the ground. CAUTION: Stop the boom just as the deck contacts the ground.)*

### SIDE

**SHIFT:** "A" Port, Side Shift Out: 8-10 Seconds

*(Position deck above ground and shift completely inboard. Then index the side shift "out" function and determine the time required for the deck to shift completely outboard.)*

"B" Port, Side Shift In: 8-10 Seconds

*(Position deck above ground and shift completely outboard. Then index the side shift "in" function and determine the time required for the deck to shift completely inboard.)*

**DECK ROLL:** "A" Port, Deck Out: 7-9 Seconds

*(Raise boom and shift deck so that deck can be articulated without contacting the boom, and roll deck in until deck cylinder is completely extended. Then index the deck roll "out" function and determine the time required for the deck to roll out.)*

"B" Port, Deck In: Target 7-9 Seconds (but DO NOT use Limit Screw)

*(Raise boom and shift deck so that deck can be articulated without contacting the boom, and roll deck out until deck cylinder is completely retracted. Then index the deck roll "in" function and determine the time required for the deck to roll in.)*

### BOOM

**SWIVEL:** "A" Port, Boom Aft: 10-12 Seconds

*(Position boom, rotate head to be level with ground, lower boom until deck is just above ground, and swivel boom full forward. Then index the boom swivel "aft" function and determine the time required for the boom to swivel full aft. Use caution when doing this, stop boom before boom contacts tire.)*

"B" Port, Boom Forward: 10-12 Seconds

*(Position boom, rotate head to be level with ground, lower boom until deck is just above ground, and swivel boom aft until near tire. Then index the boom swivel "forward" function and determine the time required for the boom to swivel full forward.)*

*(ASM-DF CALIBRATION RSS-0001)*



# ASSEMBLY

## BOOM JOYSTICK DIAGRAM (ASM-DF CALIBRATION RSS-0001A)

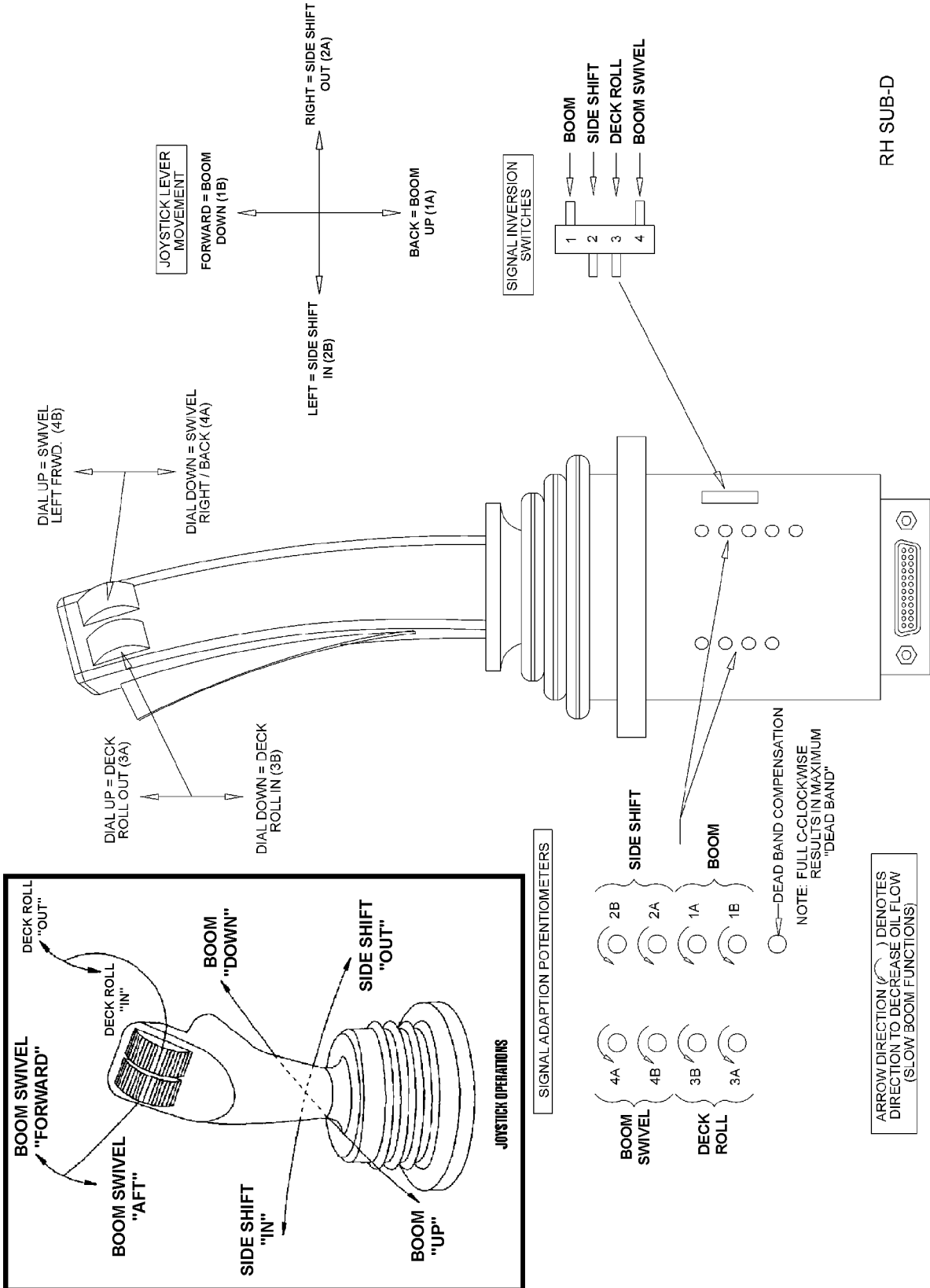

RH SUB-D





# ASSEMBLY

## REAR STOW SIDE MOWER HOSE ROUTING

**WARNING NOTE:** The sudden release of hydraulic pressure could cause the sudden movement of very heavy parts. Anyone in the way of these parts could be severely hurt or killed. To prevent hydraulic failure, DO NOT ALLOW these hydraulic hoses to BREAK or BURST. Make sure the hoses do not pinch or stretch as boom moves. Measure TWICE, check TWICE, then proceed with caution.

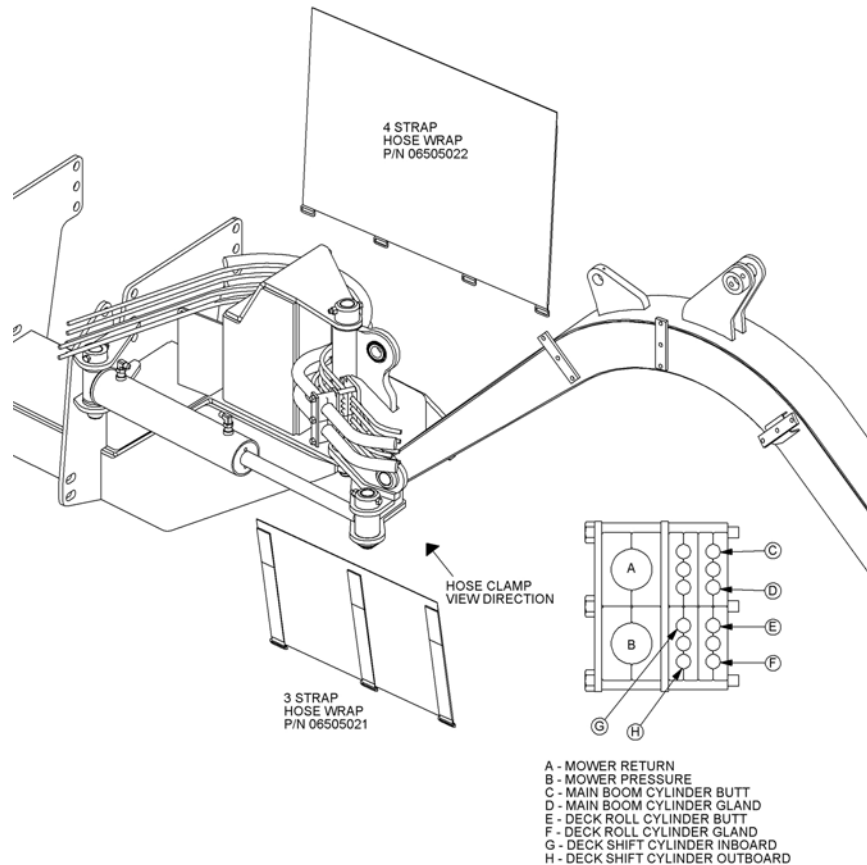

Route the hoses through the space between the swivel and the boom mounting bracket. Connect the hoses to the boom hoses and move the boom arm to a few feet from full forward. Assemble the swivel clamp and place the return hose for the motor on top and the pressure line on the bottom. Place the  $\frac{1}{4}$ " hoses in the hose clamp as shown above. Next, make sure there is enough slack for all hoses to pivot at the joint where the main boom arm bends in the swivel, as shown in the next image, and tighten the hoses in the clamp. (ASM-RSS HOSE ROUTING-0001A)



# ASSEMBLY

## REAR STOW SIDE SLIDE ASSEMBLY

TIGER RECOMMENDS USING  
LOCTITE 271™ ON ALL FASTENERS  
BEFORE INSTALLING.

A. ASSEMBLY ITEMS 2 THEN 4 INTO ITEM 6 & SECURE WITH ITEM 15 (QTY 20) (ASSEMBLING BOTH OF ITEM 2 BEFORE 4 WILL ALLOW YOU TO REACH INTO ITEM 6 AND SECURE FASTENERS MUCH EASIER).

B. SLIDE ITEM 3 IN TO ITEM 1 FROM OUTBOARD SIDE (OPPOSITE ROLLER ASSEMBLY) AS SHOWN. SLIDE ITEM 3 THROUGH ITEM 6 ONCE YOU HAVE ITEM 3 THROUGH THE OUTBOARD SIDE, THEN SLIDE ITEM 3 UP TO INBOARD SIDE.

C. ONCE ITEM 3 IS IN PLACE, SECURE INBOARD END CAP (ITEM 5) WITH ITEMS 9 (QTY 8), 14 (QTY 8) & 8 (QTY 4). LEAVE FASTENERS LOOSE TO ALLOW FOR NEXT STEP

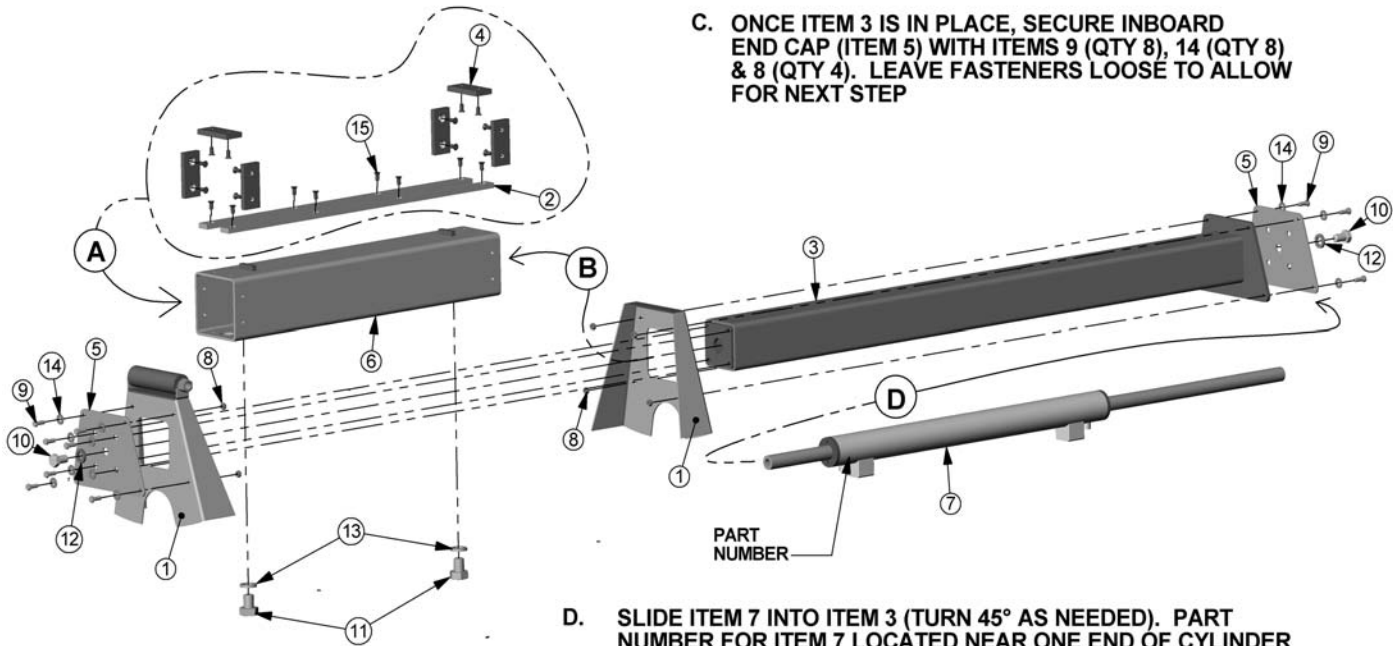

D. SLIDE ITEM 7 INTO ITEM 3 (TURN 45° AS NEEDED). PART NUMBER FOR ITEM 7 LOCATED NEAR ONE END OF CYLINDER BARREL MUST GO TOWARDS INBOARD END! LINE UP MOUNTING BLOCKS WITH HOLES IN ITEM 6. LOOSELY SECURE WITH ITEMS 11 (QTY 2) & 13 (QTY 2). LOOSELY ASSEMBLE ITEM 5 TO OUTBOARD END WITH ITEMS 9 (QTY 4), 14 (QTY 4) & 8 (QTY 4).

E. WITH ALL ITEMS IN PLACE, FIRST CENTER ITEM 3 IN OPENINGS IN ITEM 1 ON BOTH ENDS, THEN TIGHTEN FASTENERS. SECOND, TIGHTEN FASTENERS ON ROD ENDS. LASTLY, TIGHTEN BOLTS ON UNDERSIDE OF CYLINDER.

See the Slide Assembly page in the Common Parts Section for parts numbers and additional detail. (ASM-RSS SLIDE ASSEMBLY)



# ASSEMBLY

## REAR STOW SIDE FLAIL HOSE ROUTING

**WARNING NOTE:** The sudden release of hydraulic pressure could cause the sudden movement of very heavy parts. Anyone in the way of these parts could be severely hurt or killed. In order to prevent hydraulic failure, **DO NOT ALLOW** these hydraulic hoses to **BREAK** or **BURST**. Make sure the hoses do not pinch or stretch as boom moves. Measure **TWICE**, check **TWICE**, then proceed with caution.

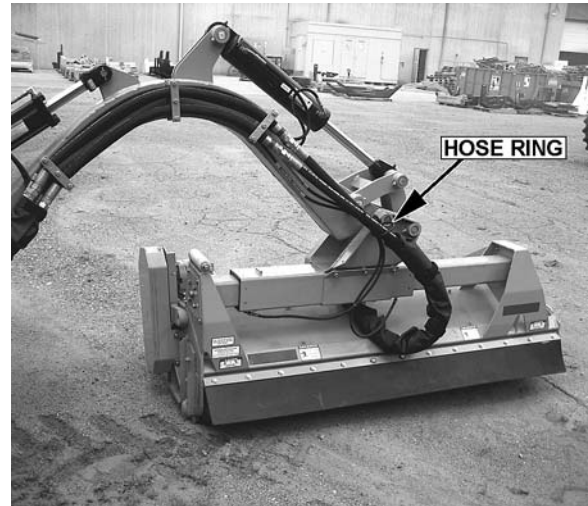
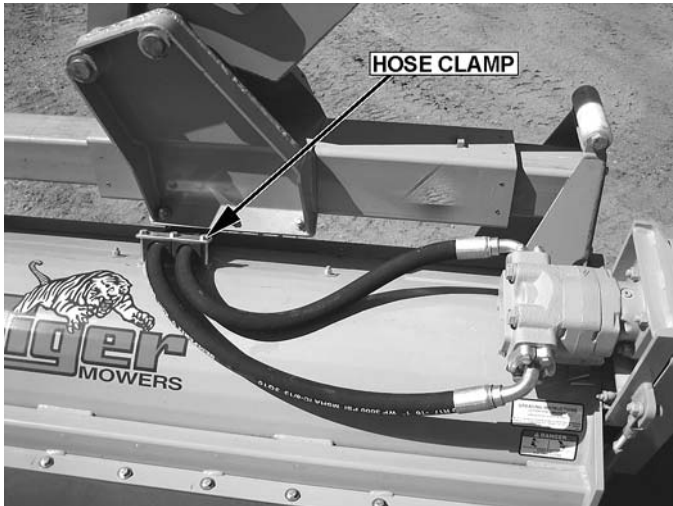

Route the hoses from the flail motor through the space between the slider assembly and the flail deck as shown above. Clamp the hoses with hose clamp P/N 35131, but do not tighten at this time. Next, route the hoses from the hose clamp through the hose ring and attach them to the boom hoses. Before tightening the hose clamp, make sure the hoses do not pinch, stretch or rub on any edges when the flail head moves through its articulation and sliding. Finally, attach the hose cover P/N 06505020 between the hose clamp and the hose ring. Refer to the Parts Section for hardware. (ASM-RSS HOSE ROUTING-0002)



# ASSEMBLY

(ASM-C-0100)

## BOOM HYDRAULIC DIAGRAM

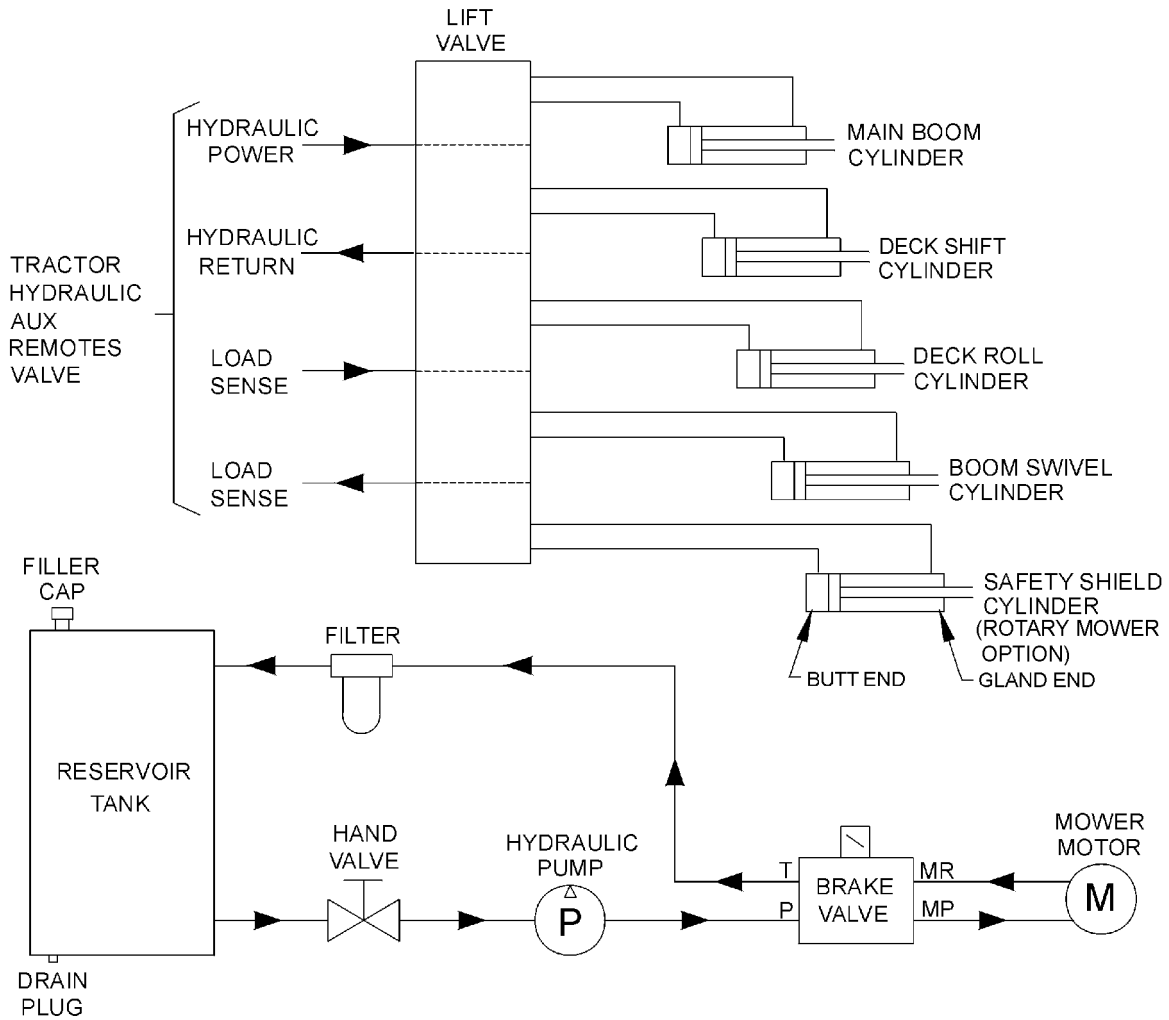

## FILLING HYDRAULIC RESERVOIR

Refer to the Maintenance Section for filling specifications and hydraulic oil requirements.

**NOTE: Starting or running your Tiger mower before filling reservoir will cause serious damage to the hydraulic pump.**

(ASM-C-0004hydro resrv)



# ASSEMBLY

## WHEEL WELL HYDRAULIC TANK INSTALLATION

Install all fittings and tubes into tank and tank filter as shown in the Parts Section illustration. Insert tank sight glass onto the tractor side of the tank.

Place the tank in the mounting bracket on the axle brace as shown in the Parts Section. Secure the tank with the hardware provided.

Install the filter gauge into the filter housing so that it points to the rear of the tractor and is clearly visible to the operator. The tank breather cap is ready for use as the tank is filled. Some of these items may already be installed. (ASM-C-0103)

## WHEEL SPACERS

When mounting a boom mower, a spacer kit is needed for both rear wheels (part # 06200637). After removing the wheels attach the spacer to the wheel portion of the axle with the hardware provided. When you are ready to re-attach the wheel, the wheel goes on first then the reinforcement ring and finally the hardware provided. (ASM-JD-0099)

## INSTALLING O-RING FITTINGS

Installing straight, 45° and 90° O-rings requires that the O-ring and washer be up against the swivel body. Insert the swivel and turn in until the swivel is pointed in the desired direction and O-ring contact is made. Hold swivel in set direction with a wrench and turn the O-ring nut away from the swivel body and carefully tighten. (ASM-C-0056)

## INSTALLING NATIONAL PIPE FITTINGS

Whenever installing a pipe fitting, wrap the threads clockwise (looking at the end) with teflon tape. In this way, the tape will be tightened when installed. NOTE: It is not necessary to tape O-ring fittings, or those installed in swivels. (ASM-C-0088)

## PREFORMED TUBE INSTALLATION

Lay booms on floor so that the side with the clamp plates is up. Locate all tube clamps and install them loosely onto the clamp plates.

Arrange the tubes and hoses as outlined in the Common Parts Section. Install the tubes closest to the boom arm first, being careful not to pinch the tubes. Place the other tubes outside of the first tubes. Snug all clamp bolts, but do not tighten. Check all tubes for correct alignment and that none are pinched or bent. The clamp bolts can now be tightened. (ASM-C-0085)

## GENERAL HOSE INSTALLATION

Refer to the Parts Section for detailed information about hoses and fittings for this application. (ASM-C-0011)

## HOSE COVERING

Secure hoses together with zip ties wherever loose. Wrap the hoses between the swivel and main boom with the hose cover provided. Wrap the hoses between the main boom and secondary boom with the hose cover provided. Where hoses may contact the frame or other edges, wrap with split hose and secure with hose clamps or zip ties.

On non-cab units, the pressure and return hoses from the control valve will also need to be routed inside the protective hose wrap. Cover the valve and valve fittings with the hose cover and secure with the string provided. (ASM-C-0058)



# ASSEMBLY

## ACCUMULATOR INSTALLATION

Install the accumulator bracket on the right mainframe mast or lift valve mount, if applicable, with the capscrews, lockwashers and spacers, if applicable, as shown in the Parts Section. Install the accumulator in the bracket and secure with the hardware shown. Install fittings and hoses to the cylinder and control valve as shown in the Parts Section. **Use teflon tape on all pipe fittings (except O-rings).** (ASM-C-0012)

## SOLENOID BRAKE VALVE

Install a solenoid valve on the mounting bracket with the supplied hardware as shown in the Parts Section in this manual. While installing the fittings to the brake valve, the electrical coil on the spool may have to be removed to make room. When reinstalling the coil, it is important to use no more than 5 ft. lbs. (or 60in. lbs.) torque. **WARNING: OVER TORQUE TO THE COIL WILL RESULT IN HYDRAULIC FAILURE OF SPOOL.** (ASM-C-0025)

## TEMPERATURE GAUGE MOUNTING (OPTIONAL)

Mount the temperature gauge where it is clearly visible to the operator. Attach the green (-) wire from the negative post on the gauge to a grounded bolt on the tractor frame. Remove paint if needed to make a good ground. Remove the pipe plug from the side of the hydraulic reservoir and install the temperature sensor using thread sealing tape. Run the white wire from the (s) sensor post of the gauge to the temperature sensor on the hydraulic reservoir tank. (ASM-C-0051)

## WHEEL WEIGHT MOUNTING

For all tractors using a boom mower, a wheel weight will be required for the rear left side wheel. It will be necessary to mount the weight in the wheel using the long capscrews, lockwashers, flatwashers, spacers (if applicable), and hex nuts per the diagram in the Parts Section.

Installation is most easily done with a fork lift, inserting a fork in the center slot of the wheel weight. The head of the capscrews is to be toward the OUTSIDE of the weight, with flatwashers on both the inside and outside of the assembly.

The left rear tire may also be filled with a mixture of water and calcium chloride at about five pounds per gallon. Tire air pressure should be maintained according to the Maintenance Section. (ASM-C-0055)

## AXLE BRACE INSTALLATION

With the tractor on jack-stands, remove the existing hardware on the rear axle where the axle braces will be mounted. Use a hoist to raise the axle braces to the correctly matching mounting holes on the rear axle and the mainframe. Use the hardware shown in the Parts Section to attach the braces to the tractor, DO NOT tighten until the mainframe has been positioned onto the axle braces. The mainframe hardware will not be tightened at this time.

When the mainframe is in position, remove the capscrews one at a time and apply a thread locking agent. Reinsert the capscrews and tighten / torque to values noted in the torque chart located in the Maintenance Section of this manual. (ASM-MF-0013)



# ASSEMBLY

## SINGLE COLUMN BOOMREST MOUNTING

Carefully lower the boomrest and align the holes with those of the axle brace. Now install all attaching hardware, as shown in the Parts Section, loosely, to allow for the alignment with the axle brace. Tighten / torque all hardware on the axle brace and the boomrest.. (ASM-JD-0251)

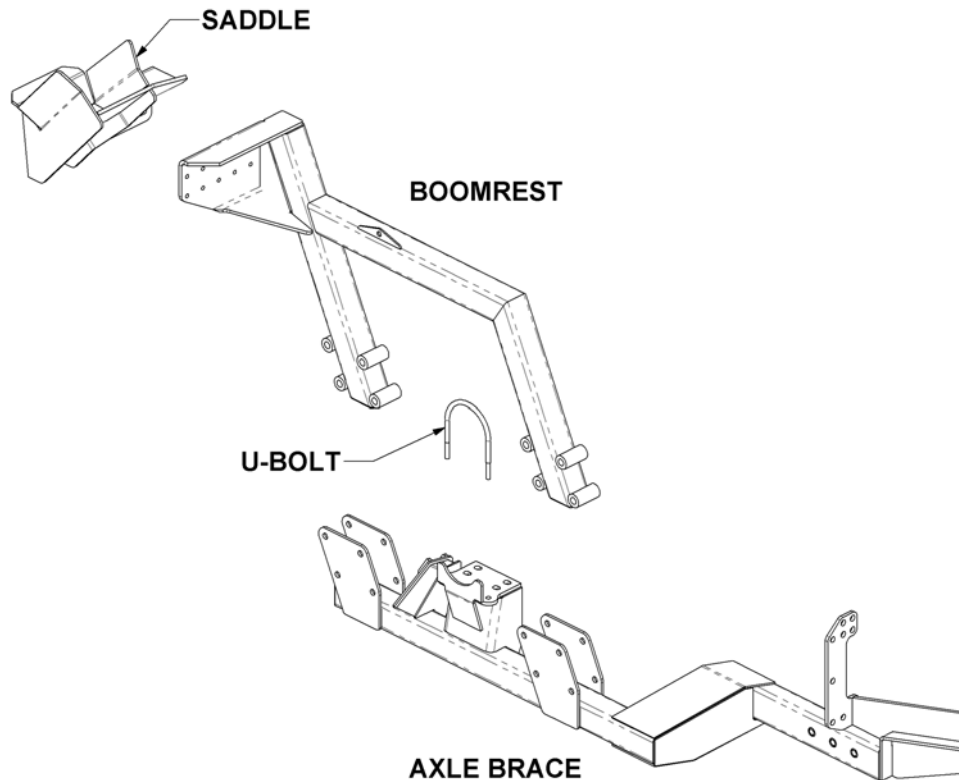

## MAIN BOOM INSTALLATION

Using a hoist, install the boom swivel into the mainframe as shown in the Parts Section. Line up holes in swivel and mainframe for large swivel pin and insert pin. Secure with hardware as shown.

Attach the inner end of the main boom to the swivel bracket with the cylinder anchors positioned upward, and at a right angle to the tractor. Secure it with the horizontal hinge pin. Secure the hinge pin in the boss with capscrews, etc. (see Parts Section).

Attach the butt end of the main boom cylinder to the swivel with the cylinder pin and roll pins shown in the Parts Section.

Install the travel lock on the rod end of the main boom cylinder. This should be facing the butt end of the cylinder after installation.

Install the fittings and hoses to the main boom cylinder per Parts Section.

**GREASE HINGE PIN ZERKS ON BOOM AFTER ASSEMBLY, ONCE UNDER LOAD WITH BOOM ELEVATED, AND AGAIN AT REST WITH BOOM SUPPORTED.** (ASM-C-0013)



# ASSEMBLY

## DECK ATTACHMENT

Attach the head to the secondary boom using the pins and hardware shown in the Parts Section to attach linkages. Install the square tube on the top of the head into the head mount and secure using the mounting plate and hardware as shown. The mount should be positioned to the left side of the cutter head. Install the deck pivot cylinder using the pins and hardware also shown in the Parts Section.

Connect the fittings and hoses from the pivot cylinder to the small preformed tubes on the boom arm. Connect the fittings and hoses from the motor to the large preformed tubes on the boom arm.

Connect all remaining hoses from the control valve to the cylinders and / or preformed tubes on the boom arm. Refer to Parts Section for diagrams.

**Before proceeding to the final preparation step, double check the complete assembly from the mainframe to the cutter head against the diagrams in the Parts Section for proper placement and assembly of all components.** (ASM-C-0060)





# ASSEMBLY

## FINAL PREPARATION FOR OPERATION

Place operator's safety and operation decals on the steering column and side console where they are clearly visible to the operator. These decals should be understood by each operator of the machine in conjunction with the Safety and Operation Sections of this book. The decals are to be maintained in good condition as a reminder to the operator, and should be replaced if damaged.

All bosses, pins and pivot points will need to be greased as instructed in the Maintenance Section of this manual. The hydraulic reservoir can also be filled with the recommended fluid (see Maintenance Section) and the filter installed in the top of the tank. Double check all fittings and fasteners BEFORE starting tractor. Also secure any loose hoses together with zip ties and wrap with split hoses where friction may occur on the hoses.



**BEFORE** starting or operating the tractor you must read and understand the Safety and Operation Sections of this manual completely.

**BE SURE THE BALL VALVES ARE OPEN!** Start tractor and allow instruments to stabilize. Using a piece of paper or cardboard as noted in the Safety and Maintenance Sections, check all fittings and connections for hydraulic leaks.

If a leak is found, you must shut down the tractor and set the cutter on the ground. Before attempting to fix the leak, you must actuate the lift valve handles several times to relieve any pressure in the lines.

**Before operating the mower**, the cutter head and boom should be slowly moved throughout the full range of motion. Watch for any condition that would cause pinching or excess stress on the hoses. The steering and front axle travel should also be carefully moved through their full range of motion. If any condition occurs in which the hoses contact the tires, the steering and / or front axle travel may need to be limited as described in the tractor operator's manual. This should also be done if the tires rub, or are extremely close to any other part of the mower, such as the hydraulic tank or draft beam. This may include adding shims or adjusting stop bolts in the tractor front to solve the problem. While checking motion, you should also check that the control circuits are connected according to the operator's decal for the valve handles.

## MOWER TESTING

Take the tractor to a place free of loose objects on the ground. Operate the cylinders through their full range of motion again, to clear the lines of air. Follow the instructions in the Operation Section to operate the mower. Vibration of the mower should be minimal at all times. After a 5 minute test run, the knife bolts should be retorqued, and retorqued once again after the first few hours of operation.

**If any parts of this Assembly Section, or any other section of this manual are not clearly understood you must contact your dealer or the address on the front of this manual for assistance!** (ASM-C-0010)



# ASSEMBLY



**CD9 F5 HCB'G97 HCB**

UJ^!aa } A^&a } A#

# CD9F5HCB

## H 9F'6CCA'ACK 9F

### CD9F5HB; 'BGHFI 7HCBG

Va^!ÁÓ[[{ •Áe^Á e} ~æc'!^áÁ ã@Á ~æc'Á æ'!æÁ^Á \]!^!•ÉÁV@ÁÓ[[{ ÁÁ ÁÁ•ã}^áÁ Áææ&@Á Áe  
dæd'!Áe} áÁ]!æ^Áçæã ~Á@æã•Á!Áe} ãÁÁæ} \*^Á Áç^\*^ææ^Á æ} e} æ&Áæ} |ææã }•ÉÁV@ÁÁ[[{ Áe} á  
@æã•Áe^Á~ }á]!^áÁ ã@Á æ^c'Á æ} } \*Áá&æç ÉÁ |! e&ç^Áá^!&ç!•ÉÁ @|á•Ée} áÁ @!Áæ^c'Áæ'!•Áç  
|! çæ^Á]!ææ'!Áe} áÁæ•^!á^Á |! e&ç} ÉÁ, ^ç^!ÉÁ [ Á @]áá \*Á ÁÉÉÁ Áæ& |æ ÉÁÇÉÁ æ^c'Á~ } { ^} e} } á  
•æ^c'Á æ} } \*Áá&æç Á ~•e^Á æ} æ} áÁ} Á@Á} ãÁ Á[[ áÁ]!ææ} æ&] } áá} Áææ|Á Á^É

QÁ Á@Á]!ææ'!Áe} |Á^•} •ææç Áç ÁÁ^Á ] |, |á^\*ææ|Á Áç|Á] e} çæÁ]!ææ} \*Áe æá•Áe} áÁ Áæ^Áç^!  
!æ } æ|Á^!&æ ç} Áç Á} •!Á} ^•^!ÉÁ @!•Ée} á æ Ée} áÁ |! |! ^!c'Áæ^Á] e} b!^áÁ!Áæ æ^áÁÁ^Á@  
à[[{ Á} ãÁæç |Á!Áæ@, ] Á áb&çÉÁ Á [ e} ]!æ^Á@Á[[{ Áe} áÁææ&@áÁ@æÁÁ^•æ} á!•ÉÁ æ•^!•á^É  
]!e Á!Áç^•ç & Áe^Á ã@Á ÁÉÉÁ^ç Á@Á} æÉ

V@Á^Á&ç} Á Á@Á]!ææ'!Áe} |Á^•} æÁ ÁÁ•ã}^áÁ Áe} áæã^ÉÁ •ç &çÁe} áÁá~ææ^Á]!ææ'!Áe} |Áe} Á@Áæ^Áe} á  
|! |! |! Á^•Á^Á Á@Á[[{ Áe} áÁææ&@áÁ@æÁÁç!^•Áç } æ} áÁ Á@Á^Á&ç} Áe^Áç e} á^áÁ ÁÁ^•^áÁe} Áe  
çã ~æÁæÁ Áe •ã e} Áç]!ææ} } \*Á@Á]!ææ} Á Áe} |! |! Áe} áÁe^Á] e} ^áÁ Áe} |! |! ÉÁV[[{ ^Á æç!^•Á æ  
•ç, Á @|á•Á^ { [ ç^ÁÁ Á} @e} &Áçã ~æ&æç ÉÁ ÖXÓUÁ]!ææ'Á@Á[[{ Á} ãÁ ã@Á ~æç|Áæ^c'Á~ } { ^} e} }  
|æ^Áe} áÁ Á[[ áÁ]!ææ} æÁ &] } áá} ÉÁV@Á]!ææ'!Áe} |Áe} |Áe} •ÁÁ^Áæ} áæÁ ã@Á@Á[[{ Á} ãÁ æ} áÁæçç!  
|! |! |! Áe} áÁç|Áæ^c'Á!æçÁ^Á^!^Á^\*á} } \*Á]!ææ} ÉÁV[[{ |! Á]!ææ} ÉÁ Áe^Áæ^áÁ Á@Á e} æÉÁ |  
@] Á} •!Á^Áæ^Á Áæ^Áe} áÁææ ççç'!Á^•Á Á@Á[[{

F958'5B8'I B89FGH5B8'Hk9'9BHf9'CD9F5HB; 'BGHFI 7HCBG'5B8'G5: 9HMG97HCB'C: 'Hk-G  
A5BI 5 @ 5B8' Hk9' HF57HCF' A5BI 5 @ 69: CF9' 5HH9ADHB; 'HC' I G9' Hk9' HF57HCF' 5B8  
-AD@A9BH' GÁ] ~ÁÁ Á [ e} } á!•æ} áÁe} ^Á Á@Á} •ç &ç} •ÉÁ } æçç[ ~!Áæ^•Áe} ç@|á^áÁæç|Áç |Áe  
~|!Áç] } æ} æ} ÉÁVæ&]!ææ'Áe} ç} Áç Áç|Áæ^c'Á} •Áe} áÁæ^c'Á ^•æ^•Áç } æ} áÁ Á@Á e} æÁe} á  
ç@^Áe} ç^áÁ Á@Á ]! { ^} e} } áÁæçç |ÉÁ(OPS-U-0001)

ÜÖÇÉÁV ÖÖÜUVÖÖÖÁe} áÁÜŠŠUY Á@Á |! |, } \*Áæ^c'Á Á^•æ^•ÉÁV!á ~•Áe} b!^Á!  
áæçç æÁ &ç!Á]!••Áe^Á Áe^Á} Áç |! |, Á@Á æ} } \*Áe} áÁe} •ç &ç} •Áæ^áÁ Á@  
Üæçç Á^•æ^•ÉÁV, æ•Á^Á[[ áÁç { [ ] Á^} •^Á Áe} ãÁe} æá•ÉÁ

**SAFETY INSTRUCTIONS**



**PELIGRO**

Uá] Á^Áç \*!•ÉÁ æææ ææææ~ } Á^ÁÁ] Áç ææ^ÁÁææ: çææ  
{ ^áææ ÁÁ^\*!ææç ÉÁ

**LEA EL INSTRUCTIVO!**



Ó[[{ U]!ææ} Á^Á&ç} ÁÉ

CD9F5HCB

# CD9F5HCB

## %CD9F5HCF`F9EI`F9A9BHG

Ùæ^Á] ^ìæå } Á -Á@Á } æ^ Á@Á | ^•[] •æåæ Á -Áæ~ æåå áÁ] ^ìæå | ÈÁÓÁ~ æåå áÁ] ^ìæå | Á@Á ^æåå } á } á^•æ } á•Á@Á ] | ^{ ^ } óæ } áÁææç | ÁU] ^ìæå | çÁÆ æ } æ } Áæ } áÁæ Áæ ] | ^{ } &^áÁ Á ] | ^{ ^ } óæ } áÁææç | [] ^ìæå } Áæ } áÁæ | Áæ • [ &ææ^áÁ ææç Á | æææ^ ÈÁÓÁæå } Áç Á@Á ææç Á ^••æ^•Á ] } æå } áÁæ Á@Á æ } æ } •ææç Á æ } •Áæ^Áæææ^áÁ Á@Á ] | ^{ ^ } óæ } áÁææç | ÈÁÓÁæ } Á æóÁ -Á@Á] ^ìæå } Áæ } áÁæ^Á •^Á -Á@Á ^~ æ { ^ } óæ Á | óæ { | ^ç | Á } á^•ç [ áæ ] • | óæ } áæ ç | á^áÁæææ^Á | Áæ { | ^ç | Á } } æå } È

ÇÁ@Á] ^ìæå | Áæ } [ óÁæåÁ@Á æ } æ } Á | Á@ { •^ç^•Á | Á | ^•Á | óæ { | ^ç | Á } á^•ç } áÁ@Á] ^ìæå } Á -Á@Á ^~ æ { ^ } óæ Á@Á^•[] •æåæ Á -Áæ~ ^ìçá | Áç Á^æåå } áÁæ ] æå Á@Á æ } æ } È ææç Á | æææ^ Èæ } á [] ^ìæå } Á •ç &ç } •Áç Á@Á] ^ìæå | È

Ùæ^Á] ^ìæå } Á -Á~ æ { ^ } óÁ~ á^•Á@Á@Á] ^ìæå | Á ^æåå } | ç^áÁU^•[] æÁU | ç&ç^Á~ æ { ^ } óçUÓUÇ | Á@Á æ } áÁæ } •Á @ } Áææç } È ] ^ìæå } È | ç&ç } Èæ } áÁæ ] æå } Á@Á~ æ { ^ } óÁUÓUÈ Áæ^á } ^áÁ ] | ç&ç^Á] ^ìæå | Á | ç&ç } Áæ } áÁæ } á^•Á@Á ] | , æ } Áææç Á ^æç

## D9FGCB5 @DFCH97HJ9`9EI`DA9BH`fDD9L

- ~ Çæ } Á ^æÁææç Á | æ^•
- ~ PæáÁæ
- ~ Ùæ^Á] ^Áææç Á | ç ^æ
- ~ Ó | ç^
- ~ P^æå } ÁU | ç&ç }
- ~ Ó | •^Áææ } Á | çæ }
- ~ Ù^• ] áæå | Á | Áçç | Áæ \ Áç^ } á^•Á } Á [] ^ìæå } Á } áæå } •È (OPS-U-0002)

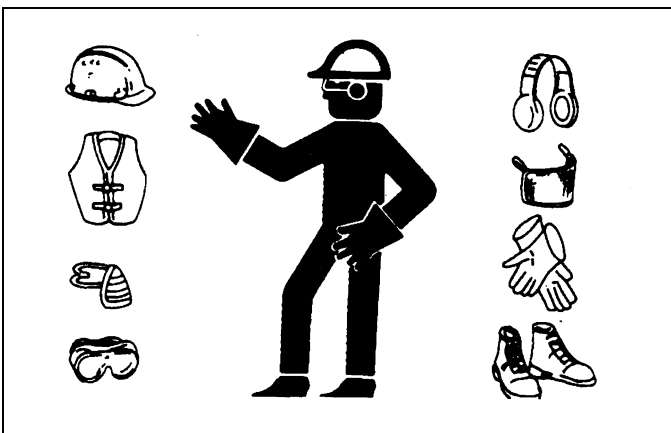

ΠΟΧΟΥΑ^•Áæi^•Á | Áæç | ç | Áæ { ^áææ^ Áæç | ^Á | Á @Á ] ^ìæå } Á@Á V | æç | Áæ } áÁæ ] | ^{ ^ } óÁi^•Áæ } áÁ æç | ç | Á, ç | Áæ^&óæ } Á ] ^ìæå | ç æ^ç^••Áæ } áÁæ [ | áæ æå } Áæ } áÁ@Á^ç | ^Áæ^&óç^Á ] ^ìæå | ç Áææç Áæ [] ^ìæå Á@Á~ æ { ^ } óÁæ^ ÈÁÓÁ^ç | ^Á ] ^ìæå } Á@Áæç | Á | ÁQ ] | ^{ ^ } óæ } Á ] ^ìæå | Á } Á | ^•&ç ç } Á | Á ç | È@È ] } ç | Á ^áææå } Á ~ óæ } • | ç æ } ^áææå | ^••æ } æÁ^ æåå } Áæ } Áæ^Á~&ç Á -Á@Á ^áææå } Á@æ , [ ^á@æ } á^Á@æ } áææç Áç Á ] ^ìæå Á@Á~ æ { ^ } óÁæ^ ÈÁÓÓÓU \ } , æ } | Áæ ] , Áæ ^ | ^Áç Á ] ^ìæå Á@Á~ æ { ^ } óÁ @ } Á@áÁæç^••Á | & [ | áæ æå } Áæ ] æ^áÁU^ìæ } •Áç | Á | Áææç Á@Á ] ^ìæå | Á | Á ç | • & } | áÁ^• | óæ Á@Á ] ^ìæå | Á } á^Á@Á } ^ } &^Áæi^•Á | Áæç | ç | Áæ } È

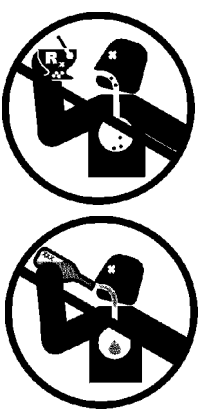

CD9F5HCB

Ó | { U ] ^ìæå } ÁU&ç } ÁÈH



# CD9F5HCB

## 8" HF57HCF

V[ A } • ^ A t e d | A c a a a c A } @ } A } ^ i a e a \* A } A t e a ~ | - e e ^ • A c @ A - o A e A t e d | A c a A t W U V A c l o a A } a a ~ {  
 a [ , } A } | & A c ^ a @ D | A t e e A a • E a } A c A | [ ~ } a A } @ } A c A t e d | A c a A } A c A | A | [ ~ } a E a A [ [ { A c A | | A c c } a ^ a  
 a } a A c A [ , ^ i A c a a / A c | a [ ] e a e a a c [ A ^ o a a [ c A c A | [ ~ } a E a c | A } a } A } @ } A c A c A c A c a a a c A } A } ^ i a e  
 [ ] A c a | A c a A } A c A t e d | E c • ^ A ^ ~ a ^ { ^ } • o a } [ A a A ^ o A } A c A a @ A c a A c A } @ } A c A a [ [ { A c  
 ^ c c } a ^ a A } A c A - o A c a A e A e ^ • & a ^ a a a [ c A c A t e d | A c a a [ A c A [ A ^ o A c A } a | a e a A c c O O U U W a } a  
 • @ ~ | a A } [ A a A } ^ i a e a A e A } • ^ o A } A c A } a A e a } A } & | A ^ • | c \* A a A } [ • a | A ^ i a } • A a B i ^ a e a A } [ ] ^ i c  
 a e a e ^ E A U V O H A c A t e d | A } [ ~ } c a A } a } A c A c • c a A e a A } A ^ o A c A a e a o A ^ ~ a ^ { ^ } o A a - i ^ A c } { ^ } d  
 ~ | o | A c • c \* A } A } [ o A ^ ~ a a A } | • • A c A } a A } A } ^ i a e a A } A c a } a } ^ i A c | A c a } A } @ } A } • a ^ i a A e a a e a  
 [ ] ^ i a e a \* A } } a a } • E

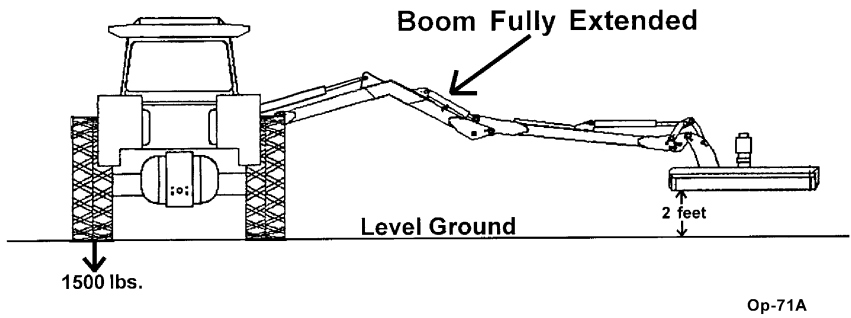

Q a c A } a A } A } ^ i a e a A } A } [ ] ^ o A } ^ i a e a A c a A } A } o e  
 a a a a } a } A } & } c | , ^ a @ } a } A } a ^ A ^ ~ a ^ a E  
 U } ^ i a e a } A } A c A } a A } A } [ ] ^ o A } ^ i a e a A c a A } A F F  
 ] ^ i & } o c E A a ^ i a e • D a } [ o A } & } { { ^ } a ^ a A } a i  
 a } ^ a a } { • e a } & • E a } A c a t e d | A } a c a A } A } ^ i a e  
 c A } o a ^ A a A } ^ i a e a A } A F F } ^ i & } o c E A a ^ i a e • D  
 • [ ] ^ i A } & } • A } @ } A } ^ i A a e A t e d | A a ^ A c a a [ ~ o A +  
 [ ] , ^ i A c a } A c A } c | A ^ a A ^ E A O P S - B - 0018

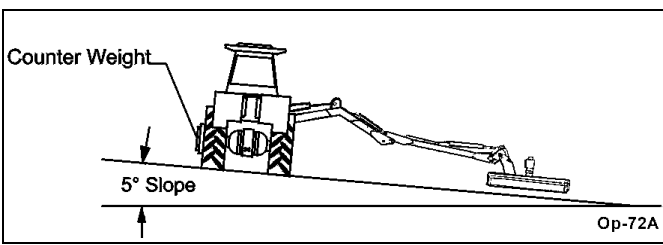

## ' : 9H5B; CB5B8 C: : H<9 HF57HCF

O t ^ A ^ c a \* A } c A c A t e d | E c A } ^ i a e | A } • o A a a a } a A } { ] | c | A } a ^ i • e a a c A } [ | ^ { ^ } o a } a A t e d |  
 [ ] ^ i a e | A } a } a } E A c a } A } a o A } A c a | A } a } a } A } [ o A } { ] | c | A } a ^ i • c [ a E a } • | o a } A e c | a ^ a A a } A }  
 a A } { ] | c | A c } | a e a } E A O P S - U - 0007

**WARNING**

O [ A ] o A [ ~ } o A } A a { [ ~ } o c A / i a e d | A } c A c A t e d | A } A } [ c a \* E A [ ~ } c  
 c A c A t e d | A } | A } @ } A c A c A t e d | A c a a e A } [ c a \* A } a e o A e A } & } { ] | c |  
 • d ] ] ^ a E a



CD9F5HCB

O [ { U ] ^ i a e a } A } & c a } A } E





# CD9F5HCB

CD9F5HCB

## ( 'GH5 FHCB; 'H<9 'HF57 HCF

V@Á] ^iæ |Á ~ • Á@æ^ Áæ [ ] | ^Á } á^i • æ ää \* Á - Á@Á | æ { ^ } &ç } Èæ äÁ ] ^iææ } æÁ • ^Á - Áæ | dæç | Áæ | d | | • Á^ - | ^Á æç \* Á@ Áæç | ÈÁ^ ç ä, Á@ Áæç | Á ] ^iæ | ç Á æ ~ æÁæ äÁæ | • | çæ Áæ ç | ä^ á ä^ æ^ Á | Áæç | Á ] ^iææ } / • d ~ &ç } • Á^ ^ á^ áÈ

Ö • ^ } æÁæç | ÁÖ | d | | • K

- " S | ææ Á@ Áæ } æç } Á^ È, æ&@
- " S | ææ Á@ Áæ } \* ä^ Á @ ç - Áæ | d | |
- " S | ææ Á@ Áæ äiææ | æÁæ | d | | Á^ ç^i • Á
- " S | ææ Á@ Áæ @ Áæ } d | | Á^ ç^i
- " S | ææ Á@ Áæ | æ^ Á^ áæ^ ææ ä Áæ ~ ç&@
- " S | ææ Á@ Áæ VU Áæ | d | | Á
- " S | ææ Á@ Áæ | ä^ Áæ & ç } d | | Á^ ç^i
- " S | ææ Á@ Áæ [ | { Á ] ^iææ \* Áæ | d | | Á^ ç^i • ææ Á | Áæ ç^ Áæ } \ D

Ö - | ^Á æç \* Á@ Áæç | Á } • | ^Á @ Áæ | | | , ä \* Áæ

- " Ö | ä ~ &ç | Á | ÁÈ æç | ^iææ } / • ] ^ &ç } Áæ äÁ ^i çæ Áæç | ää \* Á Á@ Áæç | Á ] ^iææ | ç Á æ ~ æÁæ
- " T æ^ Á ~ | ^Á æç ää • È @ | ä • Èæ äÁ ç | Á æ ç Áæ çæ • Áæ^ Á^ & ^ | ^ | / Áæ È
- " V@ Áæ ä ä \* Áæ | æ^ Áæ | È
- " V@ Áæç | Áæ æ { ä • ä } Á^ ç^i • Áæ / Áæ ä | Á^ dæ È
- " V@ Áæ [ | { Á ] ^iææ \* Áæ | d | | Áæ^ Áæ Á@ Á^ dæ Áæ ä Á - Á | • ææ } È
- " V@ Áæ VU Áæ | d | | Á^ ç^i / Áæ ä^ } \* æ^ áÈ
- " V@ Áæ äiææ | æÁæ [ | ç^ | d | | Á^ ç^i • Áæ^ Áæ Á@ Á^ dæ Á | • ææ } È

Ü^ - | Áæ Á@ Áæç | Á } ^i ç Á æ ~ æÁæ | Áæç | Áæ çç \* Á | &^ á^ | ^ • ÈÁ } | Áæ çç @ Áæç | Á @ Á^ áæ ä Áæ ä ä | ç^ á Áæ Á@ Áæç | Á ] ^iææ | ç Á^ áæ ÈÁ^ ç^i Áæ ] æ • Á@ Áæ } ææ } Á, æ&@ Á^ Á @ | ç&ä ææ \* Á@ Áæ çç | Á | ^ | æ È Çæ | Á@ Áæç | Á } \* ä^ Áæ Á^ } } ä \* Èæç | æ Áæ & ä^ } çæç } çæç, æ@ Á@ Áæç | Áæ æ { ä • ä } Áæ | Á^ ç^i ç^ áä^ } æ ä Á^ ^ ç^ | ^ ç^ á Áæç | Á [ ç^ | ^ } ÈÁ OPS-B- 0003



B^ ç^i Á^ } Á@ Áæç | Á } \* ä^ Áæ Áæç | • Á^ áä ~ ää ä \* Á | Áæ æç ~ çææ^ ~ æ^ Á^ } çæç } ÈÁ @ Á^ çç • Á^ { ^ • Áæ } Á^ Áæ æ ää | ~ • Áæ Á | ~ | Á@ æç ÈÁ^



Üæç Áæç | Á } | Á @ } Á | | | | Á^ áæ ä Áæ Á@ Áæç | Á^ áæ ÈÁ^ çç \* Áæ çæç | Áæ Á^ áæ Áæ } Á^ • | çæ Áæ | Á | Á^ áæ ÈÁ^ áæ Á@ Áæç | Á ] ^iææ | • { æ ~ æÁæ | Á | | ^i Áæ çç \* / • d ~ &ç } • ÈÁ



Ö | {

U ] ^iææ } Á^ & ç } Á È

# CD9F5HCB

CD9F5HCB

## !7CBB97HB; 5H57<-B; <958G'HC'H<9'6CCA'

FÄVÜ cäsÄà Áccas&@ \* Ác@ Á q[ óáíæá ^cçDÁq Ác@ Áí [ { ÇD ~ ä \* Á] ä Ç DÁq áÁc@sá, æ^ÉÄB^cçÁccas&@c@ Á& |ä á^!Áq á ] q[ óáíæá ^cçDÁq Ác@ Á q[ ó áíæá ^cçDÁ ~ ä \* Á] ä Ç DÁq á c@sá, æ^É

GÄV@ } Áccas&@c@ Ác^cç DÁq Ác@ Á |ä^Ác•^ { à| Ç DÁ ~ ä \* &|æ ] Ç DÁq áÁc@sá, æ^É

HÄV^ÁcÁ@ ä óç Á|, ^!Ác@ Áí [ { ÇDÁí, } Áq Ác@ Áí ^cç DÈ Ç•^!Ác@ Áí ] ^!Á q Ç DÁq [ ~ @Ác@ Áí ^cç DÁq áÁc@ Áí ] áÁ Ác@ à [ { ÇDÁíccas&@ } äc@sá, æ^É

I ÄV@ } Áq } Ác@ Áí ^cç DÁq áÁc@ Á q[ óáíæá ^cçDÁíccas&@ } äc@ ] ä Ç DÁq áÁc@sá, æ^É

Í Écä æ| Á æ^Á ~ !^Áq|Áí |o ÉÄ ~ o Écä áÁ q • Ác^Ác @ ^ áÁí !^& { { ^ } á^áÁí ! ~ ^ÉOPS-RSS-0001

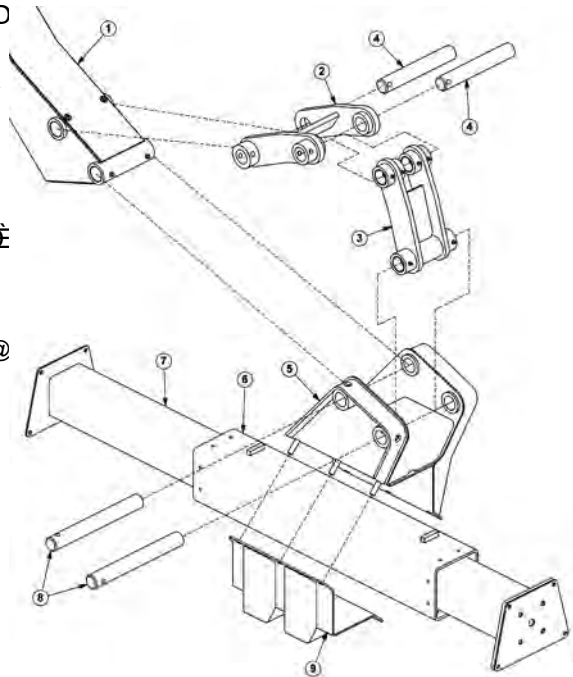

Çç [ äÁ&| } cäs@ } äc@Ç o~!-æ&•Áq &| ää \* Ác@áíæ |äÁ qÁc@s \ • ÉÄ ~ { } • ÉÄ [ ç | • Écäç^•Áq á @•^Á&| } } ^&ç | • ÉÄÜ^!äç^Ác@áíæ |äÁ !••~!^Ác^!^!Áq |íí | ä \* Á] æ| ç } æ & Á | Á^ } æ • É W•^Á | [ ç^•Áq áÁ^ Á | | ç &ç | } @ } Á^!çcäq \* Áq oÁ&| { [ ] ^ } o ÉÄO [ } cäs@ } äc@s@ o~!-æ&| !Áí äÁq } Ác@ •^Á^!q ~ Áq b | Áí [ { Áí } • Á | Á &çäq \* ÉÄÜÖH D



Ö| Á [ ó | ^!æ Ác@ ÁO ~ q { ^ } ó } äc@áíæ |äÁ qÁí Á^!Á^æ q \* ÉÄÜ q æ| áÁ^ !|Ác^Ác | | • q^Áq áÁc@áÁ |^•^ } &Á&| ~ |äÁ |^•^ } oÁc@sä äáÉÄO [ ] | Á&@&Áí | Á^æ • Á } äc@ [ ~ !Ác@s äÄP ä c | | ••~!^Á qÁ d^æ • Áí [ àíæ • Áq Ác@ Áq ^Á&| ~ |äÁ ^ } dæ Ác@ Áí q Áq áÁc@ •^Ác •^ Áqæ æ^ ä q &| ää \* Á] æ | ^ } ^ÉÄV Á&@&Áí | Ác@ •^Á^æ ÉÄP WÁc@ Á } äO P Ö Ç U Ç O Áq áÁ^ [ ç^Áq | Ác@áíæ |äÁ !••~!^ÄV ^æ Á qÁ ] ^ } dæ | Á [ ç^•É •æç Á | æ •^•Áq áÁ^ ÁO äáá [ äáÁí &@&Áí | Ác@áí } &Á^ Á qÁ^æ • ÉÄÜ ~ [ ~ Á ~ ] ^&ç | Ác@ ÉÄÜ Ö T U X O Ác@ P U U O Áq áÁc@ Áí • ç áÁc@ ÁO æ | É Ç | qÁí |^•^ } ^dæ Ác@ Áí q ÉÄÜ Ác@ Áq b | Áíæ äÁí { ^áæ | Á^ Áe ] @ • ääq Á [ , | ä^ Áæ | Áq áÁ q | áÁq Ác@ Áí | &á^ !^ÉÄÜÖH D



Ö [ { U ] ^!æq } Ä^&ç } Áí





# CD9F5HCB

CD9F5HCB

V@Ä ]^|æ[ i q Ä æ ~ æÄæ åÄ æ^c Ä ä } • Åæ æ^åÄ }  
c@Ä } æÄ[ } æÄ Ä ] [ i cæ öÄ • d ~ &Ä } • Ä } Äc@Ä æ  
æ åÄ i [ ] ^|Ä • ^Ä -Äc@Ä ~ ä { ^ } dÄT ææ æÄ c@ • ^  
ä ] [ i cæ öÄ æ^c Ä æ i ^ • Ä } Äc@Ä ] [ ^ ( ^ ) öÄ Ä [ [ ä  
& ] åæ } ÄÄ Ä } • i ^Äc@Ä { i { æÄ } Ä Ä æææ^ÄÄ  
c@Ä ] ^|æ[ i ÅæÄÄÄ ^ • È

" Ö ) • i ^ÄÄÄæ^c Ä ä } • Åæ^Ä Ä |æÄÄ äÄ \* ä|^ÄÄ  
Ü^|æÄÄ ä • ä \* Äææ æ ^äÄæ äÄ|^ \* ä|^Ä  
ä^æÄ ÄOPS-U- 0011\_A



Op-14

## ÖÜÖF ÖÄÜÜÖT ÖSÿ

" Ö ] ^Äc@Ä } åæ } Ä -Ä [ ~ } ä \* Äæ ^Ä ^|ä ( ^ ) d  
" Ö ] ^Äc@Ä } åæ } Ä -Ä, æ|^Äc@Ä ^È  
" Ö ) • i ^ÄÄÄÄ [ |cæ äÄ &^, • Åæ^Ä Ä [ • æÄ } Åæ åÄ  
æ^Ä i [ ] ^|^ Ä i ~ ^äÈ  
" Ö ) • i ^ÄÄÄ ä • Åæ^Ä Ä |æÄÄ äÄæ c } ^äÄ æÄ  
• &^ • È  
" Ö ) • i ^ÄÄæ ^ÄÄ i [ ] ^|^ Ä [ ~ } c äÄ Ä äæd i ÄÄ  
æ åÄæä, æ^ÄÄ i [ ] ^|^ • æ|^äÄ äÄ  
c@Ä ^äÄOPS-RSS-0008



Ö [ {

U ] ^|æ[ } Ä^&Ä } ÄÄF

# CD9F5HCB

## WARNING

Ü|aç^A@áiæ|æÁ|!••^!Á|q|Á|Á|á \*æ^Á æç)æ &Á|Á^]æÁ [ \Á }Á@AQ ]\{ ^}É  
 Ú|æ^Á@Á [ , ^!Á^æÁ }Á@Á| [ ] áÁ|Á^&^!Á^] [ |çáÁ }Á [ &•Á|Áæá •Éæ^)  
 çÁVUÉæ áÁ }Á -Á@Á } \*á^ÉÁ • @æ áÁ^ |Á@Á } d [ |Áç^!Á|Á | •æÁ^ç^!æÁ^  
 çÁ|aç^Á|!••^!Á|q|Á|Á|á æç \*æ^Á æç)æ &Á|Á^]æÁ [ \Á }Á@AQ ]\{ ^}É

## WARNING

Þ^ç^!Á^æ^Á@Á [ , ^!Á^æ^Á }á^áA @^Á@A@æÁÁ Á Á@Áæ^á  
 [ [ •æ ] ÉÁ@Á [ , ^!Á^æ^Á }á^áA @^Á@A@æÁÁ Á Á@Áæ^á  
 { á @æ æç^!ç)ç^Á } d^Á^Á }á^á@Á [ , ^!Á^æ^Á }á^áA @^Á@A@æÁÁ Á Á@Áæ^á



CD9F5HCB

### OUUT AEUJ AEUJOT OSY

- " Q•] ^&Á } áæ } Á -Á@Á [ [ Á } Á |á( ^) ç
- " O) • ^!Á^æ^Á }á^áA @^Á@A@æÁÁ Á Á@Áæ^á
- " O) • ^!Á^æ^Á }á^áA @^Á@A@æÁÁ Á Á@Áæ^á
- " O @ & Á } áæ } Á -Á@Á [ [ Á } Á |á( ^) ç
- " O) • ^!Á^æ^Á }á^áA @^Á@A@æÁÁ Á Á@Áæ^á
- " O) • ^!Á^æ^Á }á^áA @^Á@A@æÁÁ Á Á@Áæ^á



## WARNING

Þ^ç^!Á^æ^Á@Á [ , ^!Á^æ^Á }á^áA @^Á@A@æÁÁ Á Á@Áæ^á  
 [ [ •æ ] ÉÁ@Á [ , ^!Á^æ^Á }á^áA @^Á@A@æÁÁ Á Á@Áæ^á

### PYOUÇVSDASÇ OAD UJOOVQJP

- " O @ & Á } áæ } Á -Á@Á [ [ Á } Á |á( ^) ç
- " Q•] ^&Á } áæ } Á -Á@Á [ [ Á } Á |á( ^) ç
- " O) • ^!Á^æ^Á }á^áA @^Á@A@æÁÁ Á Á@Áæ^á

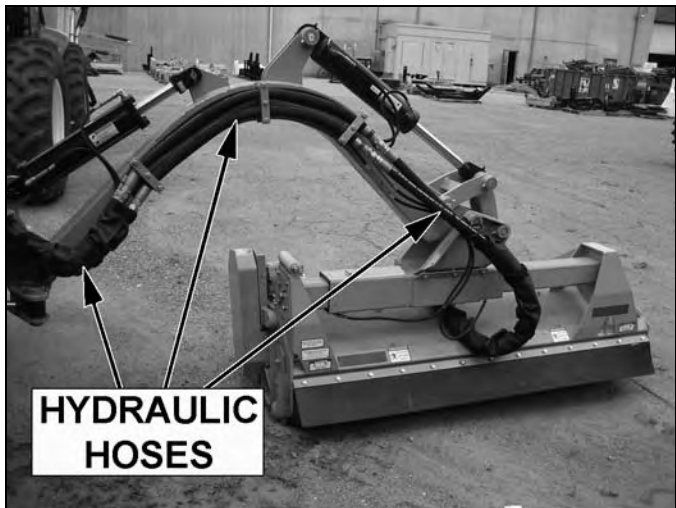

Ó [ {

U ] ^æ } Á^& } ÁÉG



# CD9F5HCB

CD9F5HCB

ÜUVÖEÿÄËÖÖÄÜÜÖÖVWÞ

- " Q. ] ^ & 0 6 | æ æ ^ • Å æ å Å | æ æ ^ Å [ | 0 Ä | Ä [ • ^ } ^ • • Ä æ å Å ç & • • æ ^ Ä ^ æ æ Å [ æ æ Ä Ä € » Ä Ä æ ^ Ä † | Å @ & ä \* Ä æ æ Å | æ æ Å | æ æ Å æ æ ^ å Å [ | ] Å æ å Å æ • æ \* Å | æ æ ^ • Å æ Å [ ] | Å ç Å ^ 0 Ä Ä Ä { æ æ æ Ä | æ æ Å æ æ æ & Ä
- " Ö. ] ^ Ä [ † | Å [ | 0 Ä æ å Å ^ 0 Å æ Å æ @ ] ^ å Ä Ä @ Ä ] | [ ] | æ Ä | ^ ^ É
- " Ö. ] ^ Ä ^ à à | Å ^ † & † | • Å æ Å Ä [ • æ æ } Å æ å Å } [ 0 Å æ æ ^ å Å | æ æ Å [ | ] Å [ \ ^ } Å æ å Å { æ • æ \* Å ^ & æ } • Å { ^ å æ | É
- " Ö. ] ^ Ä @ å å æ | Å Å ^ • Å æ Å | [ ] | ^ | Å } } ^ & ç å Å † Å @ Ä @ å å æ | Å [ † | Å @ & Ä | Å @ å å æ | Å | æ • Å } \* Ä @ • • Å æ å Å æ \* • Å Ü Å Ü V V Ä • Å ^ [ ^ | Å æ å Å | Å @ & Ä | Å | Å æ æ • Å V ^ Å æ æ å Å | Å @ æ ^ Ä æ ^ | Å | Å æ æ å | æ å Å | Å @ & Ä | Å @ å å æ | Å æ æ å • É
- " Q. ] ^ & 0 6 | Å | å æ } Å | Å & Å | æ Å @ ^ • Å æ å Å æ å, æ ^ Å OPS-RSS-0003



**WARNING**

Ö | Ä [ 0 ] ^ 0 æ æ å • Å | Å ^ ^ Ä } å | Ä [ , ^ | Å ^ & | Å 0 | æ æ ^ Å 0 [ ] æ æ 0 æ æ Å ^ • | ç æ Å ^ å ^ • Å æ æ | ^ | Å ç ^ | Å ^ æ æ Å æ æ Å } ç | Å | Ä [ ç ] Å @ Å ç [ ] ^ å æ å Å @ Å & | Å æ Å ^ & | ^ | Å [ | & Å Å ] Å



**DANGER**

Ü | Å Ü æ ç Å Ü @ | å • Å Ö ^ æ å • Å æ å Å | @ | Å • æ ç Å å ç æ • Å & | å æ \* Å ç ^ 0 Å [ 0 | å æ å Å ç D Ä Ö ^ † & † | • Å Ü ç ^ | Å Ö ^ æ å • Å æ å Å Ö ^ æ å | ç Å Ü @ | å • Å | ^ • 0 å ^ Å ^ • ^ å Å æ å Å | æ æ æ ^ å Å æ Å [ | å , [ | ] æ \* Å | } å æ } Å Ü æ ç Å ç Å ç Å ^ Å @ ^ | å Å ^ Å • | ^ & ç å æ ^ ~ | | Å ç ^ æ 0 Å æ Ä | Å | Å æ • æ \* [ | Å | \ ^ } Å { [ ] | ^ } 0 Å æ æ • æ \* Å | \ ^ } Å | Å [ | ] Å | { • Å ^ • 0 Å ^ Å | æ æ å Å ç } & Å | Å æ æ ^ & @ Ä | • • æ æ ç Ä | Å æ æ | Å | Å ^ æ ç | { Å @ [ , } Å æ 0 & Å | } æ \* | ^ ^ } Å | Å | æ æ Å | } æ ç Å

Ö [ { U ] ^ | æ æ } Å ^ & ç } Å | Å |





# CD9F5HCB

CD9F5HCB

## \* " 7i Hbj 7 ca dcbYbh-bgdYWjcb

Q.] ^&A|aa^A a^ Aa|aa^Ae • ^{ a| A^ |A@A| || , a \* K OPS-U-0031

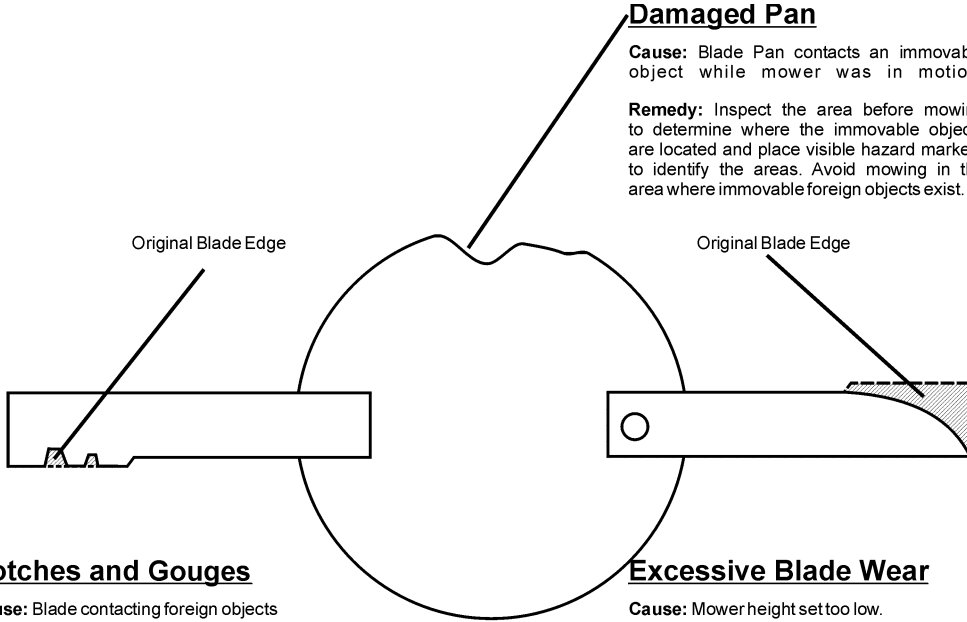

### Damaged Pan

**Cause:** Blade Pan contacts an immovable object while mower was in motion.

**Remedy:** Inspect the area before mowing to determine where the immovable objects are located and place visible hazard markers to identify the areas. Avoid mowing in the area where immovable foreign objects exist.

### Notches and Gouges

**Cause:** Blade contacting foreign objects

**Remedy:** Inspect the area to be mowed and remove foreign objects that could cause damage to the blades

### Excessive Blade Wear

**Cause:** Mower height set too low. Blade used past intended life.

**Remedy:** Replace blades more often. Adjust mower height for mowing conditions to eliminate blade-to-ground contact

Op-22



Q.] ^&A@A|aa^Aa a^ A^ |Aaa} [ |{ a^ ^aE UOUSCEOOU VPAOSCEOUA } A@Aa| a| Q T OOOVOSY A a@ |A|aa^A@e K

- " Ó&{ ^A^} a|A^ |{ ^aA| { Aa| a a a^ a^ |
- " O^ ^Aa. Aa^Aa a|E| A
- " Ö^ | A^ ^\* ^• A@A|aa^A^ | -aa^A^ | ^• ^} a|
- " Ö[ ^\* ^• A|&@ ] ^aAa^a A@A^ ca \* Aa^Aa^Aa^\* ^ | A@A|aa^A^ | { a| A
- " V@A a^ |aa^ | A@Aaa^ \* Aa^A@e A^ | A| } Aa a^ A^ | ^A@A|aa^A^ | { D-

Oa| ^A^ |Aa| } [ |{ a^ | A| } A|aa^A^ a^ Aa^A^ Aa a d[ ] @Aa| ^A^ A@A|aa^A^ aA^ & a| A^ A@ a| [ \^ ] A a a^ a^ | ^} a| ^• A| & A^ @A^ a^ Aa^ ^A^ | a^ ^• A| a^ A^ b| ^ A| A^ a^ OPS-U-0032

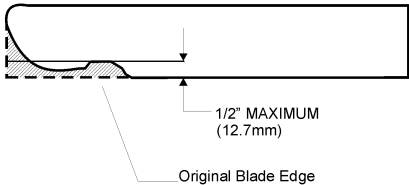

**NOTE:**  
Replace Blades in pairs after no more than 1/2" (12.7mm) wear  
Op-23

Ó[ { U| } A^ & a| } A^ |

# CD9 F5 HCB

## Tractor PRE-OPERATION Inspection



O qy gt "F %aaaaaaaaaaaaaaaaaa      O cng aaaaaaaaaaaaaaaaaaaaaa  
 F cvg < "''''''''''aaaaaaaaaaaaaaaaaa      Uj ktv aaaaaaaaaaaaaaaaaaaaaa



6 YZ:fY W: bXi W]b[ 'H Y' ]bgdYW]cbž a U\_Y gi fY'H Y fUWcf'Yb[ ]bY' ]g'cZZ U''fcU]cb  
 \ Ug'grcddYX' UbX' H Y fUWcf' ]g' ]b' dUf\_ k ]H 'H Y dUf\_ ]b[ 'VfU\_Y Yb[ U] YX" A U\_Y gi fY  
 H Y' a ck Yf' ]g' fYgh]b[ ' cb' H Y' [ fci bX' cf' gYW fY mi V'cW\_YX' i d'UbX' U'' \ mXfU' ]W  
 dfYggi fY\ Ug' VYyb' fY ]y YX"

CD9 F5 HCB

Kgo	Eqpf kxqp 'cv'Uctv' qh'Uj ktv	Ur gekhe'Eqo o gpw' k]pqv'QMO
Vj g' hruj kpi 'hki j w'hwpevqp'r tqr gtnf		
Vj g' UOX' Uki p'ku' ercp'cpf 'xkukrg		
Vj g' ktgu'ctg'kp' i qaf 'eqpf kxqp' y kj 'r tqr gt' r tguwmg		
Vj g' y j ggn' hwi 'dqm'ctg' ki j v		
Vj g' tcevt' dtcng'ctg'kp' i qaf 'eqpf kxqp		
Vj g' uvgt kpi 'hpnci g'ku'kp' i qaf 'eqpf kxqp		
Vj g' tg'ctg'pq' xkukrg'qk]hgcm		
Vj g' j { ftcwke' eqpv'qnu'hwpevqp'r tqr gtnf		
Vj g' TQRU'qt' TQDU' Ecd'ku'kp' i qaf 'eqpf kxqp		
Vj g' ugcvg'n'ku'kp' r rceg'cpf' kp' i qaf 'eqpf kxqp		
Vj g' 5/r qkp' vj ke j 'ku'kp' i qaf 'eqpf kxqp		
Vj g' f tcy dcf' r kpu'ctg'ugewgn' kp' r rceg		
Vj g' RVQ' o cngt' u j krf 'ku'kp' r rceg		
Vj g' gpi kpg' qk] hngxgn'ku' hwm		
Vj g' dtcng' hmkf' rngxgn'ku' hwm		
Vj g' r qy gt' uvgt kpi 'hmkf' rngxgn'ku' hwm		
Vj g' hgn' hngxgn'ku' cf gs wcvg		
Vj g' gpi kpg' eqqrcp' hmkf' rngxgn'ku' hwm		
Vj g' tcf kvqt' ku' hgg' qh' f gdtku		
Vj g' ct' hngt' ku'kp' i qaf 'eqpf kxqp		

Qr gtevtat' Uki pcwtg < \_\_\_\_\_

**DO NOT OPERATE an UNSAFE TRACTOR or MOWER**

V@AQ • ] ^ & ca } A ] { ; A ae A ^ A ^ A ^ A ~ | aae a Af ; A cca a } | a • E

O [ { U ] ^ { aae } A ^ & ca } A E i

# CD9F5HCB

## Boom PRE-OPERATION Inspection



O qy gt "K %aaaaaaaaaaaaaaaa

O cmg aaaaaaaaaaaaaaaaaaaaa

F cvg<"\*\*\*\*\*"aaaaaaaaaaaaaaaa

Uj klv aaaaaaaaaaaaaaaaaaaaa



6 YZ:fY Wc bXi W]b[ ' H Y ]bgdYW]cbžā U\_Y gi fY'H Y fUWcf 'Yb[ ]bY'jg'cZZU''fcHU]cb\ Uq  
 glcddYX' UbX' H Y fUWcf ' ]g' ]b' dUf\_ ' k ]H ' H Y dUf\_ ]b[ ' VfU\_Y Yb[ U] YX" AU\_Y gi fY' H Y  
 a ck Yf ' ]g'fYg]b[ ' cb' H Y [ fci bX'cf'gYW fYmiV'cW\_YX' i d'UbX'U'\ mXfU' ]WdfYggi fY\ Uq  
 VYyb'fY ]Yj YX"

Table 1:

Kgo	Eqpf kklq'cv'Uctv' qh'Uj klv	Ur gekle'Ego o gpw" kh'pqv'QCMO
Vj g'Qr gtcvtai'O cpwcrku'lp'yj g'tcevqt		
Cmluchgv 'f gecni'ctg'lp'r meg'cpf 'rgi kdr		
Vj g'o qwpvpi 'htco g'dqnu'ctg'lp'r meg'cpf 'vki j v		
Vj g'dqgo 'eqppgevkp'dqnu' 'r kpu'ctg'vki j v		
Vj gtg'ctg'pq'etcemi'lp'dqgo		
Vj g'j { ftcwle'e { rpf gtu'r kpu'ctg'vki j v		
Vj g'j { ftcwle'r wo r 'j que'eqppgevkpu'ctg'vki j v		
Vj g'j { ftcwle'xcxkg'eqpvqni'hpvevkp'r tqr gtn		
Vj gtg'ctg'pq'rgcnkpi 'qt'f co ci gf 'j qugu		
Vj g'j { ftcwle'qkl'rgxgriku'hw		
Vj gtg'ku'pq'gxkf gpeg'qh'j { ftcwle'rgcni		
Vj g'drcf gu'ctg'pqv'ej kr gf . 'etcemgf 'qt'dgpv		
Vj g'drcf g'dqnu'ctg'vki j v		
Vj g'f ghgevqtu'ctg'lp'r meg'cpf 'lp'i qaf 'eqpf kklq		
Vj g'dqgo 'uj lgrf u'ctg'lp'r meg'cpf 'lp'i qaf 'eqpf kklq		
Vj g'unkf 'uj qgu'ctg'lp'i qaf 'eqpf kklq'cpf 'vki j v		
Vj gtg'ctg'pq'etcemi'qt'j qgu'lp'dqgo 'f gem		
Vj g'j { ftcwle'o qvt'o qwpvpi 'dqnu'ctg'vki j v		
Vj g'dqgo 'j gcf 'ur kpf rg'j qwukpi 'ku'vki j v'cpf 'hwdtlecygf		

Qr gtcvtai'Uki pcwtg<

**DO NOT OPERATE an UNSAFE TRACTOR or MOWER**

0 [ {

U] ^! aā } Á^ &ā } ÁĒİ

CD9F5HCB

# CD9F5HCB

CD9F5HCB

Equipment 'O qy gtu

Control panel for the CD9F5HCB, showing various hydraulic functions and their corresponding symbols.

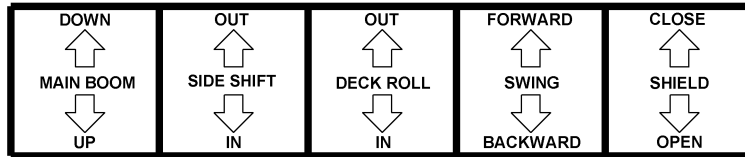
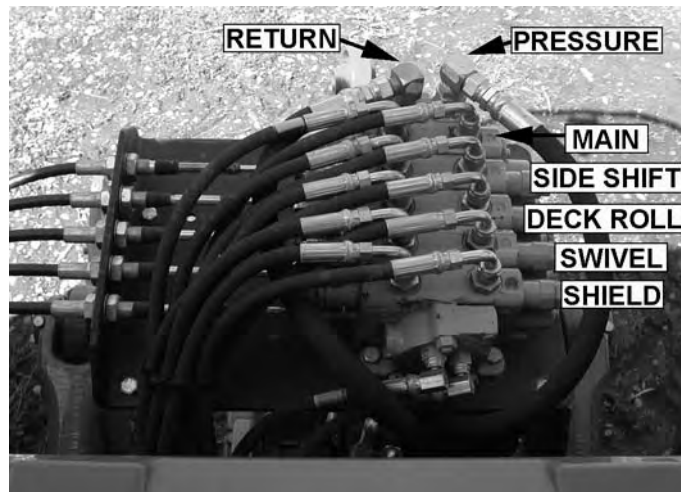
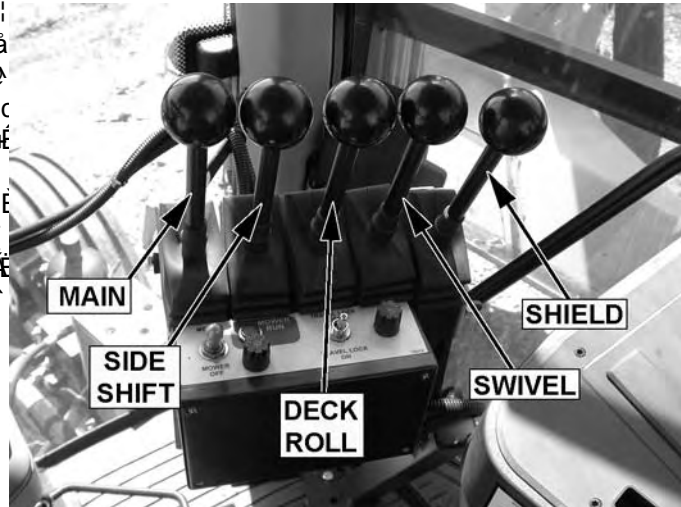

Diagram illustrating the hydraulic control panel layout, showing the positions of the MAIN, SIDE SHIFT, DECK ROLL, SWIVEL, and SHIELD levers.



Ó[[{

U] ^!æq } Á^&ç } ÁÆJ

# CD9F5HCB

CD9F5HCB

## \* 'Y 'Gk JHW Vcl

V@ÁÚæ^c ÁÚ@|áÁ^ç^iÁ ] ^} • Áæ áÁ&| [ • ^ • Á@Á @|á  
 || &æ^áÁ } Á@Á [ ] çÁ Á@Á&^ c^! Á@æÉY @) Á [ çá \*  
 æÁ! Á ^æÁ@Á! [ ~ } áÉæ, æ • Á@æ^Á@Á @|áÁÁ Á@  
 &| • ^áÁ [ • æá } ÉY @) Á [ , á \* Áá Á@Á! ~ • @Á! Áá  
 ç^ • Áæ [ ç^Á! [ ~ } áÁ^ç^! Á@Á @|áÁ æ Á^Á ] ^} ^á  
 †! Áæ á! Á&^ çá \* ÉÚ^æáÁæ áÁ [ || , Á@Á æ } á \* Á }  
 ç@Á^ &ç^ Á @ , } Á^ [ , ÉÚ [ Á [ ç^ } Á@Á&^ c^! Á@æ  
 á ç Á æ^! æÁæ \* ^! Á@æ Á ^Áæ ^c^É

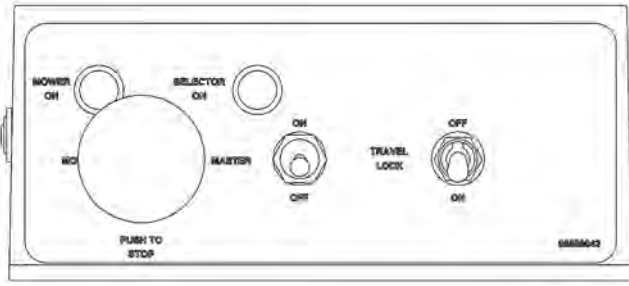

DANGER

SAFETY SHIELD & DEFLECTOR OPERATION

<p style="text-align: center; font-weight: bold;">SAFETY SHIELD</p> <p style="text-align: center; font-weight: bold;">DEFLECTOR</p>	<ul style="list-style-type: none"> <li>• Failure to close Safety Shield and Deflector may allow objects to be thrown outward with great force which can cause property damage, bodily injury, or death.</li> </ul> <ol style="list-style-type: none"> <li>1. Keep Safety Shield and Deflector fully closed when cutting grass and weeds to reduce possibility of objects being thrown outward by the Blades if persons are in the area.</li> <li>2. Before Cutting brush, trimming limbs, or other such operations, raise the Deflector and Safety Shield fully to allow the blades to contact the material if area is clear of passerby. Operator must stop cutting and close shield if passerby enters the thrown objects area or blade contact area.</li> <li>3. Repair or replace Safety Shield and Deflectors as needed.</li> <li>4. Always transport with Safety Shield and Deflector closed.</li> </ol>
---	--

02967867

Ó [ { U ] ^! æá } Á^ & çá } ÁÉÖ

# CD9F5HCB

CD9F5HCB

ΣΧΟΔΙΑΣΜΟΣ ΑΝΟΙΧΤΩΝ

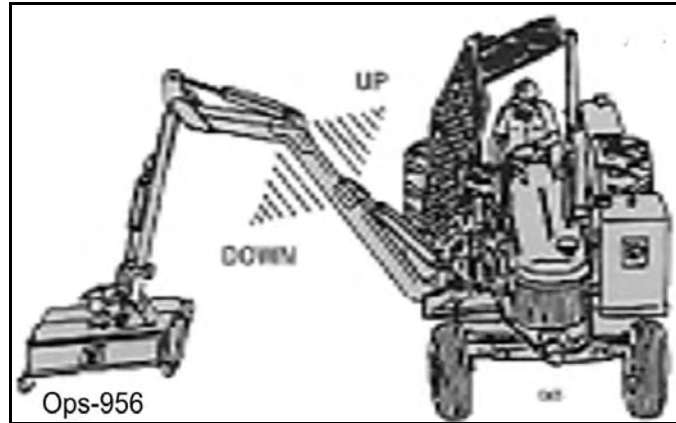

ΣΧΟΔΙΑΣΜΟΣ ΑΝΟΙΧΤΩΝ

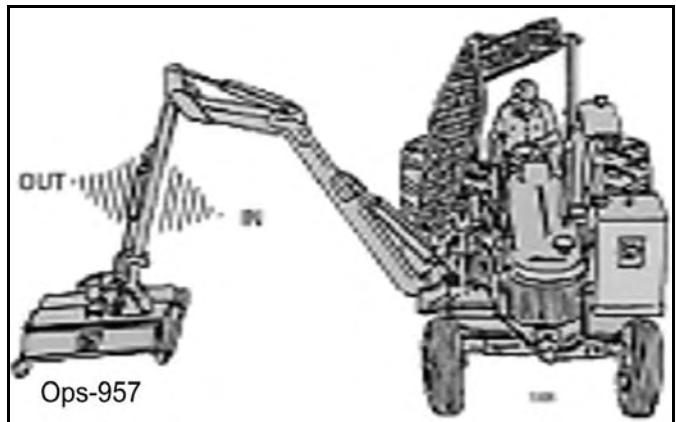

ΣΧΟΔΙΑΣΜΟΣ ΑΝΟΙΧΤΩΝ

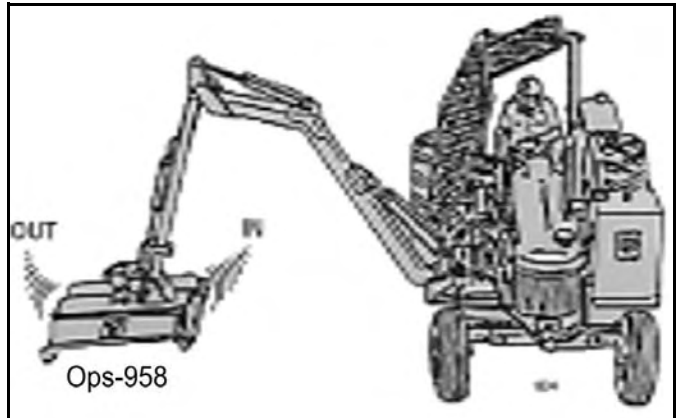

Όλες οι πληροφορίες σχετικά με τον εξοπλισμό μας, μπορείτε να τις βρείτε στην ιστοσελίδα μας.

Όλες οι πληροφορίες σχετικά με τον εξοπλισμό μας, μπορείτε να τις βρείτε στην ιστοσελίδα μας.

# CD9F5 HCB

CD9F5 HCB

ΣΧΟΔΙΑΙ ΑΟΥΤ ΑΥ ΑΟΣ

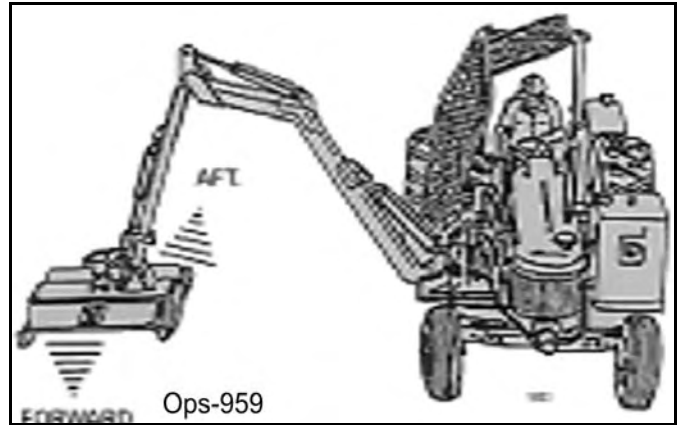

ΣΧΟΔΙΑΙ ΑΟΥΤ ΑΥ ΠΟΣ

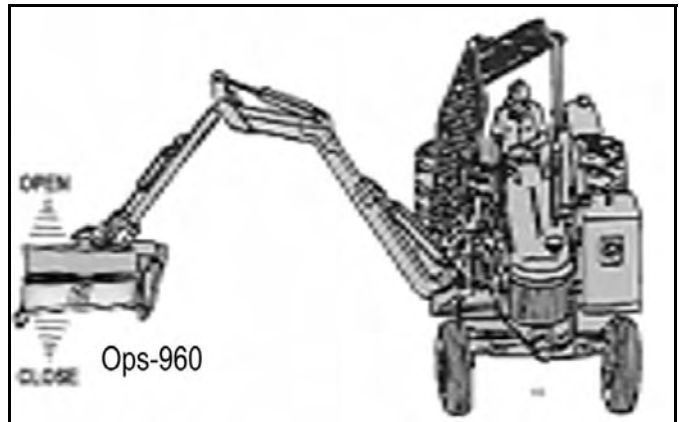

Ó[ {

U] ^! aā } Á^ &ā } ÁEGG



# CD9F5HCB

CD9F5HCB

## +">cnghjW '7 cbhfc`YX'Ack Yfg

**⚠ WARNING** ɒUVòK8C'BCHÁ] ^!æ^Á [, ^!Á@æáÁ @^Á[[{ Á [, ^!Á^Á Á@Á[[{ Á^•dÁ!Á Á@Ád!^á ] [•æ] ÁU^áÁ, ^!ÁU^ } +Á @Á áææ•Á [, ^!Á ÁU^P+É

V@Á[[{ Á } &ç] •Á^Á&ç] d[||^áÁ^ Á^Á^&d[] æÁ^ •æÁ ÈV@Á^ ^•æÁ Á^ æ^ÁU, æ&ç] æ^Á^•Á@Á^ •æÁ &ç] d[Á^!Á&ç] d[||á \*Á@Á[[{ Á [ç] Á^ } &ç] •ÈV@Á, æ&ç] Á^ Á^Á^Á@ÁU^U^Á [•æ] Á @} Á^æç \*Á@ dæç!Á^ áÁ @} Á[[{ Á^Ád, ^áÁ!Á^æ}][ç \*Á@Á æ&ç] ^É

**⚠ CAUTION** Q^c@Á^ •æÁ &ç] d[Á^Á [ç] ^!ææ \*Á [[^!ÉÇ] Á@Á^ æ^Á^, æ&ç] Á@ÁU^U^Á [•æ] É Q^c@Á@Á æ^ æ^æç^Á@æ á!^Á d Á^æç^Á^ áÁ] ^!æ^Á@Á } &ç] •Á^ áææ^ æ^ Á^ Ád, Á[[{ É ÇE^!Á[[{ Á^ Ád, ^áÁ^Á^•dÁdæ}][ç@Á] æÁd Á@Á^ æ^ ç} æ^ Á^æ çæ Á^ á&ç] æ&ç] ^! V^Á^Á^æ^!Á^!Á^ •ææ &ç] É

**⚠ CAUTION** 8C'BCHÁ^ { } çÁ Á] ^!æ^Á@Á^æç^Á^ æ^ æ^Á^!Á [, á \*Á] ^!ææ] •Á

P[çKÚ •ç \*Á æ^ æ^æç^Á@æ á!^Á^ çÁ!Á%æ æ^Á[[{ Á@Á^æç!ÁææÁ çÁáá \*Á@Á^ æ^ à[[{ Á% çÁ æ^Á @Á^ çÁ[[ Á^Á&Á^ çÁáá, ç^!Á[[{ Á^çU^||á \*Á^ æ^ æ^Á@æ á!^Á^, æ^ÁææÁ çÁ^c { æ^ Á[[{ Á^, } +Á^ á \*Á^Á@Á çÁ[[ Á^Á&Á^ çÁáá, ç^!Á[[{ Á^, æ^Á^

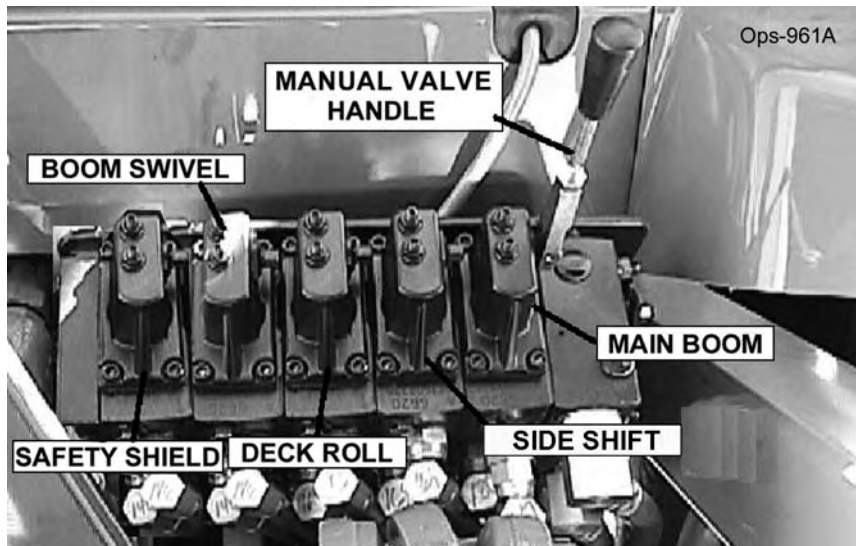

Ó[[{ U] ^!ææ] Á^ &ç] Á^ÇH

# CD9F5HCB

CD9F5HCB

## Control Panel

The control panel is located on the right side of the mower deck. It contains the following controls:

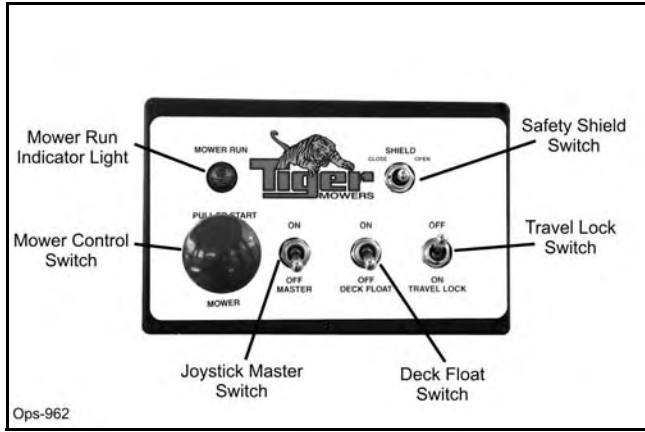

Always use the control panel correctly to avoid injury. The Safety Shield Switch must be closed before the mower can operate. The Joystick Master Switch is used to control the mower's movement. The Deck Float Switch is used to control the deck height. The Travel Lock Switch is used to lock the mower's travel.

! **DANGER**

**SAFETY SHIELD OPERATION**

- Failure to close Safety Shield may allow objects to be thrown outward with great force which can cause property damage, bodily injury, or death.

1. Keep Safety Shield fully closed when cutting grass and weeds to reduce possibility of objects being thrown outward by the Blades and to prevent contact with the Blades if persons are in the area.
2. Before cutting brush, trimming limbs, or other such operations, raise Safety Shield fully to allow the blades to contact the material if area is clear of passersby. Operator must stop cutting and close shield if passerby enters the thrown objects area or blade contact area.
3. Repair or replace Safety Shield as needed.
4. Always transport with Safety Shield closed. Ops-963

Always use the control panel correctly to avoid injury.

# CD9F5HCB

CD9F5HCB

>cmghjW '7 cbhfc`

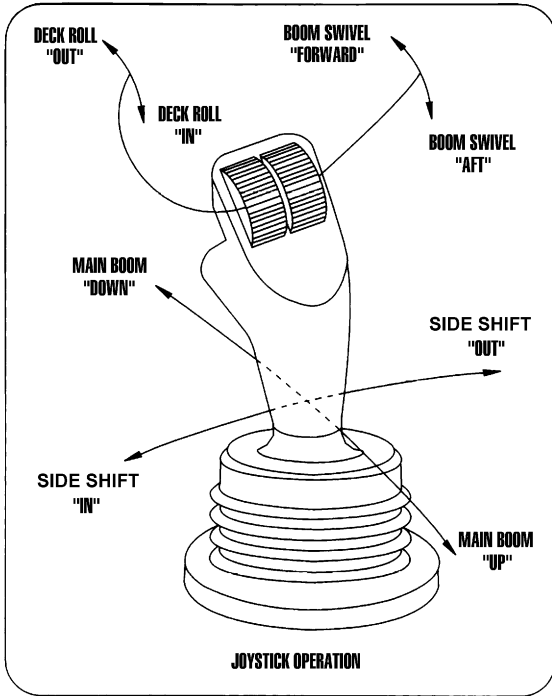

RUÿÙVÔSÁY ÖÖÖSÁ UXÒÚÁ CD ÁÓUT

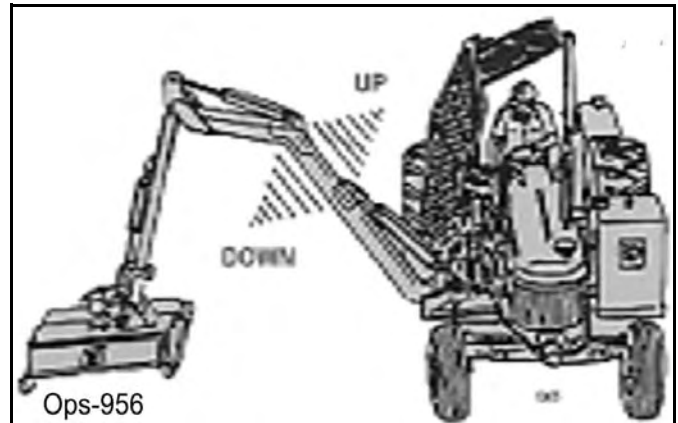

Ó[[{

U] ^! aã } Á^ &ã } ÁÉÉ

# CD9F5 HCB

CD9F5 HCB

RU'YUVOS S0VBJ0PVAP0VUAP0A000SAJ00  
VUAJ00

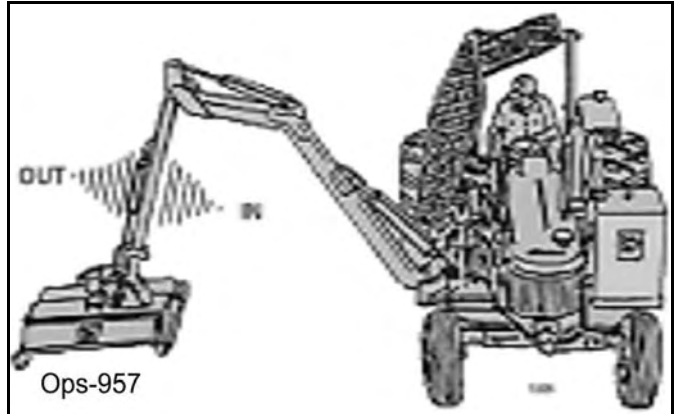

S0VAVRU'YUVOSAJUS00UAT UX0UAD00SAJUS0

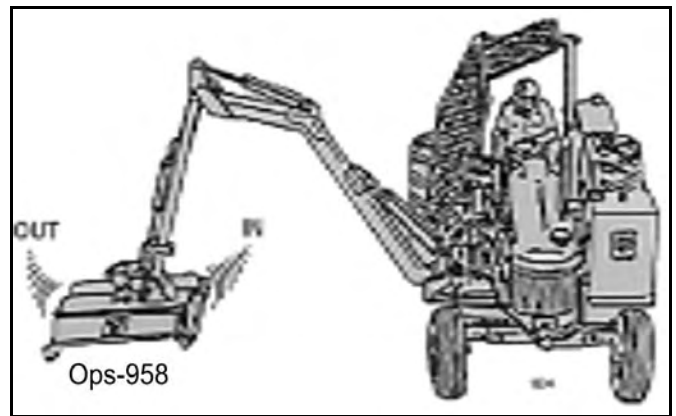

U0PVAVRU'YUVOSAJUS00UAT UX0U A 0UUT  
UY 00S

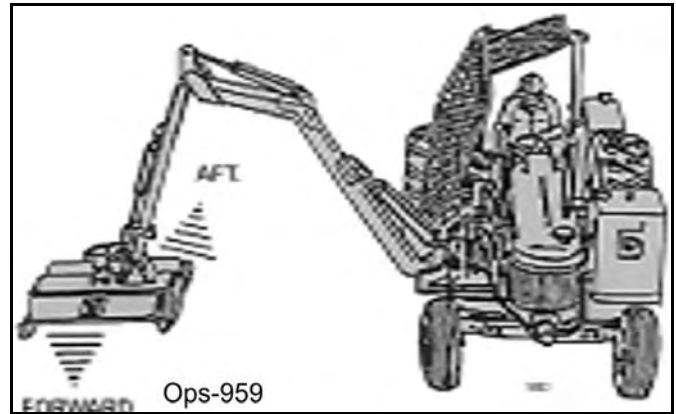

011{

U] ^!aa } A^&a } AEE

# CD9F5HCB

CD9F5HCB

ÜPÖŠÖÁ ÜY QÖPÖ } Á•, æ@ à[ eDÁ UÚÖÜÖ/ÖÜ  
UÖÖVYÁUPÖŠÖ

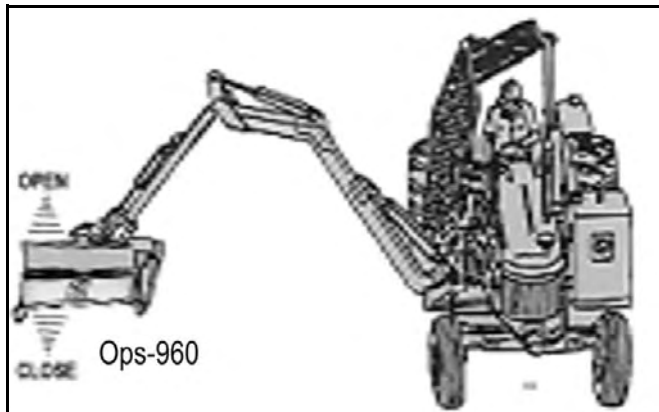

## .'8F=J-B; 'H<9 'HF57HCF'5B8`-AD@A9BH

ÜæÁææd |Áæ } [ |oÁ~`ã•Á@Á ] ^ææ |Áæ |Áæ [ ••••Áæ@ | [ \* @Á ] , |ã\*^Á -Á@Á [ á^Áãã \*Á ] ^ææ á  
æ áÁ |^ææ ç } •Áæ Áæ Áæ @Áããã \*Á æ@æ Áæææ@áÁæ ] |{ ^ } dÁÖ } •^Á@Áææd |Áæ Á@Áææ ææç Áæ  
ææ á^Á@Áæ ^ã @Á -Á@Áæ [ { Áæ áÁ@Áææd |Áæ ] ^ææ \*Áæ ] d [ |•Áæ^Á^oÁ |ÁææÁææ } [ |dÁÁ Áæ } •^Áææç  
 , @Áãããã \*Á@Áææd |Áæ æ@ææ [ { Áæçã, Á@Áæ || , ç \*É

Ü^ææÁæÁææç Áæç d` &ç } •ÉÖ^æç Áæ } Á@ÁÖ [ { Áæ } Á [ ~ Áæ æææ |æææ áÁæ ~ |ç |Áæææá•ÉÜ [ { ^Áææç  
æ^Áæææ@áÁæ | •^Áæ Áæ æçÁ -Á@ÁÖ [ { Áæ @^Á@Áæææ [ ••æ^ÁæææáÉÁÜ^ææ Áæ áÁæ æ^Áæ~ |^Á [ ~  
~ } á^•ææ áÁ@Áææç Áæ ^••ææ^Áæ^ |^Á [ ~ Áæ ] ^ææÁ@Áæ ] |{ ^ } dÁÁÁ^ Áæ |Áææç Áæ |Áææ Áæ áÁæææ |^É  
Ü^ |ææÁæ | •oÁ |Áæææ æ^áÁææç ÉÁ^Á |Áæ Áææç Áæ&ç } Áæ |Áæ [ |^Áæ |{ ææ } É

S^ |ÁæÁæ | • [ ] çÁæ |Áæ |Áæ Áæ Áæ [ , ^Áæ ç &Áæææ^Áææ Áæ@ , Áæ áb&ç Áæ æ@Áæ^Áæ |Áææ |Áææ } •æ^Áææ |  
áæ çæ &Áæ ÖÖÜÁÖÖÖÜÁÖPS-B- 0005



Þ^ç^ |Áæ ] ^ææÁ@Áææd |Áæ |Áæ ] |{ ^ } oÁ } çÁ [ ~ Á@æ^ÁææÁææ á  
& [ ] |ç |Áæ } á^•ææ áÁ@Áæææ æææ@Áææd |Áæ ] ^ææ |ç Áæææ ææææ á  
^ææç -Á@Áææç Áæ^•ææ^Áæ } áÁæ Á@Áæææ ææ |Áæ } Á@Áææd |Áæ á  
Q ] |{ ^ } dÁÁÁ^ æ } Áæ , Áæ Áæ |Áæ -Áææd |Áæ } \* çÁæ~ áá^ |Áæ Áæ  
^ { ^\*^ } & ÉÁ^ç^ |Áæ | , Áæ |ç |Áæ } &áÁæ |Áæ dææ ^áÁæ | • [ ] ^ |Áæ Áæ ] ^ææ  
ç@Áææd |Áæ |Áæ ] |{ ^ } oÁ æç oÁ ] ^ |çãã } ÉÁæ æ^Áæ~ |^Á@Áæ ] ^ææ |  
çæ Áæ |Áææææ áÁæ } á^•ç [ áÁ@Áæææ æææ |Áæ |Áæ ] ^ææ } ÉÁÖÖD



Öæ, æç Áæ çææ Á@Áææç Áæ } •Áæ Á [ { áÁæææ |Áæ } áææ } ÉÁ@Áææç Áæ } •Áæ^Áæ æç \*É  
áææ æ^áÁæ |Áæ } |Áæææ |Áæ æææ Áæ áÁæ •ç |Áæ ] ææ { ^ } oÁæç Áæ } •Áæ { ^áææ | ÉÁÖÖD

Ö [ { U ] ^ææ } Áæ&ç } ÁæÉ









# CD9F5HCB



ប្រសិនបើអ្នកប្រើប្រាស់មានការប្រយោជន៍ មិនអាចប្រើប្រាស់បានដោយសុវត្ថិភាព ទាំងស្រុង ទេ បើបើកប្រើប្រាស់មិនតាមការណែនាំរបស់យើង ទេ មិនអាចទទួលបានលទ្ធផលប្រសើរ បានទេ ។



ការប្រើប្រាស់ប្រយោជន៍ មិនអាចប្រើប្រាស់បានដោយសុវត្ថិភាព ទាំងស្រុង ទេ បើបើកប្រើប្រាស់មិនតាមការណែនាំរបស់យើង ទេ មិនអាចទទួលបានលទ្ធផលប្រសើរ បានទេ ។

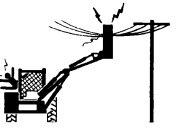

## - "CD9F5HB; 'H<9'6CCA' I B#5B8'5H57<98'<958

H<9' CD9F5HCF' AI GH' 7CAD@H9 @' I B89FGH5B8' <CK' HC' CD9F5H9' H<9'HF5' 7HCF' 5B8 ACK9F'5B8'5 @'7CBHFC @'69: CF9'5HH9ADHB; 'HC'ACK' "AV@' លើកលែងតែ ក្នុងករណី ដែលមានការប្រើប្រាស់ មិនតាមការណែនាំរបស់យើង ទេ មិនអាចទទួលបានលទ្ធផលប្រសើរ បានទេ ។

លើកលែងតែ ក្នុងករណី ដែលមានការប្រើប្រាស់ មិនតាមការណែនាំរបស់យើង ទេ មិនអាចទទួលបានលទ្ធផលប្រសើរ បានទេ ។

លើកលែងតែ ក្នុងករណី ដែលមានការប្រើប្រាស់ មិនតាមការណែនាំរបស់យើង ទេ មិនអាចទទួលបានលទ្ធផលប្រសើរ បានទេ ។

លើកលែងតែ ក្នុងករណី ដែលមានការប្រើប្រាស់ មិនតាមការណែនាំរបស់យើង ទេ មិនអាចទទួលបានលទ្ធផលប្រសើរ បានទេ ។



ការប្រើប្រាស់ប្រយោជន៍ មិនអាចប្រើប្រាស់បានដោយសុវត្ថិភាព ទាំងស្រុង ទេ បើបើកប្រើប្រាស់មិនតាមការណែនាំរបស់យើង ទេ មិនអាចទទួលបានលទ្ធផលប្រសើរ បានទេ ។



ការប្រើប្រាស់ប្រយោជន៍ មិនអាចប្រើប្រាស់បានដោយសុវត្ថិភាព ទាំងស្រុង ទេ បើបើកប្រើប្រាស់មិនតាមការណែនាំរបស់យើង ទេ មិនអាចទទួលបានលទ្ធផលប្រសើរ បានទេ ។

CD9F5HCB

លើកលែងតែ ក្នុងករណី ដែលមានការប្រើប្រាស់ មិនតាមការណែនាំរបស់យើង ទេ មិនអាចទទួលបានលទ្ធផលប្រសើរ បានទេ ។









# CD9F5HCB

CD9F5HCB

## UWAGA

Ważne informacje dotyczące bezpieczeństwa. Należy uważnie przeczytać instrukcję obsługi i przestrzegać wszystkich ostrzeżeń. Nie należy używać maszyny, jeśli nie jest się odpowiednio przeszkolonym. Przed rozpoczęciem pracy należy sprawdzić stan techniczny maszyny i upewnić się, że jest ona w pełni sprawna. Należy również pamiętać o odpowiednim zabezpieczeniu się przed urazami. Wszelkie zmiany lub naprawy należy wykonać zgodnie z instrukcją producenta. Nie należy modyfikować maszyny. Wszelkie pytania należy kierować do producenta.

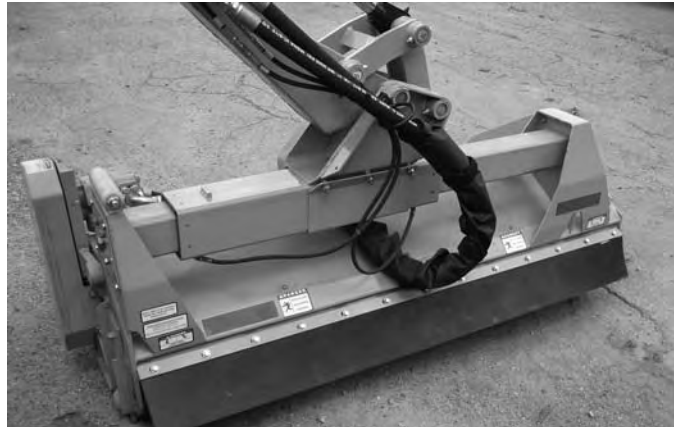

### UWAGA

Przed rozpoczęciem pracy należy sprawdzić stan techniczny maszyny i upewnić się, że jest ona w pełni sprawna. Należy również pamiętać o odpowiednim zabezpieczeniu się przed urazami. Wszelkie zmiany lub naprawy należy wykonać zgodnie z instrukcją producenta. Nie należy modyfikować maszyny. Wszelkie pytania należy kierować do producenta.

### NEBENGEFAHR

Ważne informacje dotyczące bezpieczeństwa. Należy uważnie przeczytać instrukcję obsługi i przestrzegać wszystkich ostrzeżeń. Nie należy używać maszyny, jeśli nie jest się odpowiednio przeszkolonym. Przed rozpoczęciem pracy należy sprawdzić stan techniczny maszyny i upewnić się, że jest ona w pełni sprawna. Należy również pamiętać o odpowiednim zabezpieczeniu się przed urazami. Wszelkie zmiany lub naprawy należy wykonać zgodnie z instrukcją producenta. Nie należy modyfikować maszyny. Wszelkie pytania należy kierować do producenta.

### NEBENGEFAHR

Ważne informacje dotyczące bezpieczeństwa. Należy uważnie przeczytać instrukcję obsługi i przestrzegać wszystkich ostrzeżeń. Nie należy używać maszyny, jeśli nie jest się odpowiednio przeszkolonym. Przed rozpoczęciem pracy należy sprawdzić stan techniczny maszyny i upewnić się, że jest ona w pełni sprawna. Należy również pamiętać o odpowiednim zabezpieczeniu się przed urazami. Wszelkie zmiany lub naprawy należy wykonać zgodnie z instrukcją producenta. Nie należy modyfikować maszyny. Wszelkie pytania należy kierować do producenta.

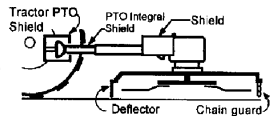

### UWAGA

Ważne informacje dotyczące bezpieczeństwa. Należy uważnie przeczytać instrukcję obsługi i przestrzegać wszystkich ostrzeżeń. Nie należy używać maszyny, jeśli nie jest się odpowiednio przeszkolonym. Przed rozpoczęciem pracy należy sprawdzić stan techniczny maszyny i upewnić się, że jest ona w pełni sprawna. Należy również pamiętać o odpowiednim zabezpieczeniu się przed urazami. Wszelkie zmiany lub naprawy należy wykonać zgodnie z instrukcją producenta. Nie należy modyfikować maszyny. Wszelkie pytania należy kierować do producenta.

UWAGA

UWAGA







# CD9F5HCB

CD9F5HCB

## %%D`UWb] `6cca `5fa `cb`6cca `5fa `FYgh!': cf`GHbXUX`9ei ]da Ybh

Ó^f|^Át}•][|c} \* Át}d|Á^c ^} Á| &æ} • ÉÁ|^  
 c@Át}d|Á} \* ã^ÉÁã^} \* æ^Ác@Ácæ@áÁ@æÉ  
 æ} áÁ æÁ|Á|@æÁ [c] Á| Á| { ^Á| Á| { }|^c  
 •d] ÉÁ|æ^Ác@ Á|[ { Á| Á• Á| d|æ^Á|æ|Á^Á•c  
 •~][|c} áÁc@ Á| } Ác@Á^•æÁ æc|Á, æ&@Á  
 c@ÁUØÁ [•æ} ÉÁ



- " Ü^dæcÜ^& Á| ||&|ã} áÁ|Á| { }|^c|^É
- " Üc@Á [ , ^|Á|Ác@Á æÁ^É
- " Ü^dæcÜ^c@Á|[ { &|ã} áÁ|Á| { }|^c|^É
- " Ü, ã\*Á|[ { ÁæÁ|[ , |Á} çÁÁ Ádæ @Á  
 àæÉ
- " Öc} áÁc@Á^& Á| ||&|ã} áÁ|Á} çÁc@Á [ , ^|Á  
 æÁ•æ| çÁc@Áæá|^É
- " Üc@Ác@Á [ , ^|Á|Á} çÁc@Á| ||^Á} \*æ^Ác@Á  
 à|c| { Á^Ác@Áæá|^É
- " S| , ^|Ác@Á|[ { Á} çÁ [ , ^|ÁæÁ|çÁ Áæá|^É



V| Á^| [ç^Ác@Á|[ { Á|[ { Ác@Á|[ { Á|Á•ÉÁæ^  
 c@Á|[ { Á| { }|^c|^ÉÁUc@Ác@Á [ , ^|Á^c} ç  
 c@Á|[ ||^Ááã^} \*æ^Ác@Á•æá|^ÉÁÜ^dæcÜ^c@  
 Ö^& Á| ||&|ã} áÁ|Á| { }|^c|^ÉÁc} æ| ÉÜ, ã\*Ác@  
 Ó|[ { Á| , æáÉ

OPS-RSS-0009

## %%&HfUbgdcfHb] `cb`Di V`TWFcUXk Umg

Öcd^ { ^Áæ ç} Á @`|áÁ^Á•^áÁ @) Át}•][|c} \* Ác@Át}d|Áæ} áÁ [ , ^|Á } Á^`à|æÁ|æ, æ•ÉÁV@Át}d|  
 { ~•óÁ^Á~ã|^áÁ æ@Á|Á^`áÁÁæcÁ} æ} \*Áæ^Á•Áæ &| áã \*ÁæÜT XÁ| à|^ Áæ} áÁæ ç} \*Á} æ} ã\*  
 |ã @Á| Á|c}á|Á^•Á^Ác@Át}d|çÁ|^•) &ÉÁ|^ Á| à|^Ác@Á|æ, æ•Áæ^Á|ã æã^Á•ã)^áÁ|Áæ d| [c}^  
 á|æ|^Áæ} áÁ [•óÁ|Á^•Á} çÁ|Á| óÁ|Á|[ çÁ^Á|Á|~ÉÁ|^Á|^ÉÁ|^Á|^•óÁ|[Á|^óÁ|Ác@Á|Á|^Áæ  
 çá, Á| çÁ|[Á|^~} d|Áæ} áÁ^ { ^| à|^Ác@Á^çÁ|Á^•Á} çÁ|Á|] |æ@Á|æ|^Áææ•^Á|Ác@Át}d|çÁ|[ , ^|  
 •]^áÉÁ^Ácd^ |Á|Áæ ç} •Á @) Ác@Á} &Á^~ã} çÁ|^) óÁc@Á|^Áæ^Á|ã} \*ÉÁ} æ^Ác@Ác@Át}d|Áá  
 , æc@Á} æ|Ác} á•Á^|[ ]áÁ|^Áæ} ^Á^Ác@Á|æÉOPS-B- 0014

Ó|[ { U|^æ} Á|&ç} ÁÉU

# CD9F5 HCB

CD9F5 HCB

V@Á ÚT XÁ ÇJ||, È [ çã \* Á X^ @^DÁ ^\ à\{ Á ã  
 ~} ã^!•æÁ•^ { à|Á~•^áÁ\ ã^ |óá!ã^!•Á [ -Á@  
 ]!•^•) &^Á -Á~ ã { ^} óÁæ^|ã \* Á } Á [ æ, æ • Áææ  
 •||, Á•] ^^áÉÁÚT XÁã } • Áæ^ÁæÁæã \* |æÁá!ã @  
 [|æ \* ^Á ã @^!^+&ã^Á^áÁç Á\ |Áá| @^!æ^ Áæ  
 æ áÁ\ ã @^ ã ããæ ÉÁT æ^Á• ^!Á@ÁÚT XÁã } ã  
 &^æ Áæ áÁçã ã^!Á [| Á@Á^æÁ -Á@Á } ã^! ç |^  
 dæ • [| ç \* Á@Áæç | Áæ áÁ\ ] |^ { ^} ó } ã^ à|æ  
 | [ æ, æ ÉÁÚ^ | æ^Á@ÁÚT XÁ^ à\{ ÁáÁ-æ^áÉ  
 áæ æ^áÉ | Á [ Á ] \* ^!Á^+&ã^É OPS-U-0020



Op-43

T æ^Á• ^!Á@Áæ^!Áæç | Áæ @ \* Á æ} \* Áã @ É  
 @æ!ã @ É æ áÁ à!æ^Éæã @ Á æ^Á~ } &ç } ã \*  
 ] [| |^! Áæ^+!Á [| &^áã \* Á [| ç Á ] ~ à|æÁ | æ • É  
 Y @^!Á, ^!Á [| à^!Áæç | • Á@Á^! | ç Á -Á @ã \*  
 ç Á | [ çã^Á æ} ã \* Áã } æ^! Áæ áÁ |^!æã \* Áã @ã \* É  
 { | • ó [| à^!Á [| à^!Á, @!^!Á [| Á^~ ã ] ^!Á, ã@  
 [| ^!æã \* Áã @ ÉÁÓ ] • | óæ Áæ @ | á^áÁæç |  
 á^!Á | Áã @ã \* Á æ Áæ áÁ [ ááæã } • Áæææ |  
 ç Á } \* | æ^Á@Áã @ã \* Á [ Á | à^!Áæç | Á [| à^!É  
 OPS-B-0015



Op-103

Y @} A [| ^!æã \* A [| Á ~ à|æÁ | [ æ • É @æ^  
 & } • ã^!æã } Á\ | Á @!Á | æ^Á • ^! • ÉÚ || Á Á@Á ã^  
 [ -Á@Á | æ^! &æ ç } æ^! Á | Á |, Áæ | Á | |, ã \* Áæ-æ  
 ç Á æ • ÉÓ [ Á | ó &^áá@Á^\* æ^! ^^áÁã ã^!ó  
 ^ |^!Á æ^! Á | Á ~ } ãæ æ^! Á | Áæ | æ | ç | æ^!æç | • É  
 Ç, æ • Áæ æ^! ó @ } Áæ } [| ç \* Á@Áæç | Áæ á  
 { |, ^!Á } Á ~ à|æÁ | æ • ÉÓ ] ^!æã^ Áã Á • ^!Áæ • É  
 @ Á [| { Á ç } á • Á\ Áã @ Áæ ç | Á@ } Á@Áæç | •  
 , ã@Á [ Á^!ææ~ | Á@!^!Á^! Á • æ á^! • É [| ^É  
 | æ^! Á à^! d^ &ç } • Á | Áæ ^! Á @Á^ Áæ áÁ^ Á  
 ] æ^! -Á@Á [|, ^!Á@æã | Á [| { ÉÁ^!Áæ ç } Áæ á  
 |^!á &Á ] ^^áÁ@!Á @Á^! Á | Á^!á • dæ } Áæ^! Á  
 @ Áæ^! OPS-B-0016



Op-104

Ó [ { U ] ^!æã } Á^&ç } ÁÉ €

# CD9F5HCB



⚠ **DANGER** Ɔ^ç^iA[ , &@ai^} A|A c@iA^i[ ] • A[ Aã^A } A@A iæd iA: AQ ] |{ ^} dE  
 Qe[ã \* A - Aæ} A^~ |o[ã A^iã ~ • A[ b^i^ A |A^æ@E[ ]



⚠ **WARNING** T æ^A^iæ[ A@A@A^i[ , AT [ çã \* AX^ @A^ AQT XDã } A[ A[ çã^ãA[  
 • &@A[ æ Aæ A[ A^A^iæ[ A[ çã A^iã } A^iã \* A^iã A^iã @ } A[ çã } ] [ çã \* A@  
 Ö ~ ç { ^ } o^ ^ A@ A^iæd iA:æ @ } A[ æ } ç \* A[ã @ Aæ} aA[ ] [ , Aæ[ A[ &æ  
 dæ-ãA^~ |æ[ ] • E[ ]

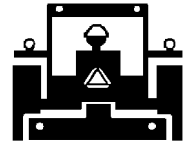

Ü^ã & A] ^^ãA^i^iA^i } çã \* A^iã } | çã \* A@A iæã^E  
 Ö } ~ |^A@A[ çã i æ^A^iã } Aæ^A[ & ^ãA[ \* ^ç  
 , @ } A[ ^iæ[ \* A[ ] A^iãA[ æã^E OPS-U- 0023



Op-25

## U^i^b^h^Y^H^U^w^f^U^b^X^a^d^Y^a^Y^b^h

Ö^i^i^A^iæ } ] [ çã \* Aæ[ æã^ãA^iæd iA:æ} aA[ ] |{ ^} dE  
 { ^æ ~ |^A@A@ã @æ} aA[ æc@ã^ ^ } • çã } aA[ ] •  
 , ^ã @A^ A@A[ { ] |ç^A[ æã^ãA[ ] æ^iã } • |^A@A@  
 [ ] æãA[ çã^ãA[ A[ { ] ] æ} & A[ æ@A@A^ \* æA[ æ^A^A[ i  
 çã^æ æ@A[ çã^ãA[ æ^iãA[ ] ~ \* OPS-U- 0024



Op - 46



⚠ **DANGER** Y @ } A[ çã } ] [ çã \* A[ [ [ AT [ , ^iA } Aæ^ & A[ A[ çã^iA@A@ã @A[ A[ æc@  
 { æ^A^æ^ãA^ \* æA[ æ^A[ @ } A@A[ [ [ A[ A[ çã^A[ çã^A[ çã^A[ ] [ çã ] [ çã ] E  
 Ö [ ] æãA[ æ^iãA[ iA[ ç^i^ @æãA^ d^ & ç^i^ A[ iA[ ] , ^iA[ çã^A[ çã^A[ çã^A[ çã^A[  
 ] [ ] ^iç Aæ[ æ^A[ iA^iã ~ • A[ b^i^ A |A^æ@E[ ] A^iã & • æ^ A[ , ^iA[ [ [ çã  
 i^ã & A@ã @æ} aA[ iA^iã [ ç^A[ ] , çã \* A@æA[ A^ã^ & A[ æc@A[ çã^A^ \* çã  
 |ã ~ E[ ]

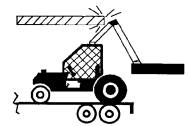

Ö [ [ [

U ] ^iæ[ ] A^ & çã } A^ E F

CD9F5HCB

# CD9F5 HCB

CD9F5 HCB

W^A x~ x| A • a^A A x aA | x^A A d x^A • A x a  
 ^~ q { ^ } o d A d x } [ | o c @ A x x d | A x a A q ] | ^ { ^ } d E  
 O | } • | o x A x o | a^A A x x | A | A x c | { q^A A @ A | | ^ |  
 ^~ q { ^ } o A^~ a^A A V q \* A x x ~ x | A a^A A & x • E  
 @ x^ A c A d x • E x x | • A x a p | A q a^A • E A & | ^ | A x  
 a [ , } A [ o c @ A | { } o x a A x a A - A @ A x x d | A q a q \* A @  
 | | | ^ | A A A A [ , } A | & x x } • A x A | ^ x a a^A A A o A x x d |  
 { x } x x c | ^ | EOPS-U- 0025



Op-47

O E | x \* ^ A c @ A & x • A • [ A c x A , @ } A c x } ^ a E A c @  
 & x • A x a A ~ | | q \* A [ , } x a A x a A x x x • c  
 o { • ^ | c ^ • E A x x ~ | | A x c } A c A A & | q \* A & x • A |  
 [ c @ | A x c } ^ | • A • q \* A a [ { | ^ | A | A a q a^A • A | A x } |  
 { x x ~ { A c } • q } E A A ^ A c d ^ { ^ A x x A , @ }  
 x x x @ \* A x a A ^ { | c q \* A c A A & | q \* A c x x • A x A c  
 ^ c d ^ { ^ A c } • q } A q c | c^A A , @ } A | ^ x a^A A c @  
 | | c } x x A | x x a c A | q ~ • x b | ^ E



Op - 48

Y @ A x | q \* A c @ A d x d | A x a A q ] | ^ { ^ } d E { x ^  
 [ & x q } x A • d } • A d A & @ & A c x A c @ A d x d | A x a  
 q ] | ^ { ^ } o c x A | o | c^A A | A c x a A x a A c @  
 • A & | q \* A & x • A c x A x x x a^A } • q } E A A | q \*  
 d x } [ | o x x a A | x x q \* E x c } A | } q \* E | A , ^ | c q \*  
 x x } A x a A | ^ | { ^ a E d | A x c @ A ^ c o A x A | & x }  
 d | x • | ^ x c @ A A & | x A - A @ A | x x EOPS-U- 0026

**CAUTION** Q A x x | A A | o | ^ | ^ d ^ A c | E x c | A [ { A q | A } a A A , q \* A , x a • A c @ A | , ^ | A x x E x x A c @ |  
 | ^ | • [ ] } ^ | A x x A x x } d | A A , q \* q \* A | c } A } @ } A | q a^A | q A A { | c^A E x x A ~ | ^ A c  
 | ^ | • [ ] } ^ | A x A | o x x } • x } A | A c @ A | A ~ • @ a A A A , q \* q \* A [ | E

U^ d x c A , x | A | q a^A A x a A & | ^ A A x x A x x ^ E A | o x [ { A | , x a A A c @ A } c | A A x x a E | , ^ | A & A } d  
 c @ A x x | A a E x a A @ o | - A c A x x d | E V @ A x x d | A x a A @ A | , ^ | A c x x A @ ~ | a A | , A & x x a A A [ , } A & | ^ |  
 d A c @ A x x | A a E

**CAUTION** Q A x ^ A x o | A c @ A | ^ | x x x \* A & c | E | A x ^ A c @ | A A & c } A A c @ A x x x x A A | o x { | | c |  
 ~ } a^A • d [ a E x } x x A [ ~ | A V a^A A x x | A | A c @ A x x a^A • A | A c @ A x c^A | A c @ A x x x x A |  
 x • a x x & A

O | { U | x x } A A & c } A E G

# MAINTENANCE SECTION

Maintenance Section 4-1

# MAINTENANCE

## General Instructions

Tiger Mowers are designed for high performance and rugged durability, yet with simplified maintenance. The purpose of this section of the manual is to help the operator in the regular servicing of the mower. Regular maintenance at the intervals mentioned will result in the maximum efficiency and long life of the Tiger Mower.

When you purchase a Tiger Mower you also acquire another valuable asset, Tiger's parts organization. Our rapid and efficient service has guaranteed the customer satisfaction for many years. Tiger parts keep up with the demands for efficiency, safety and endurance expected of the Tiger Mower.

## Maintenance Precautions

- Be sure end of grease gun and zerks are clean before using. Debris injected into bearings, etc. with grease will cause immediate damage.
- DO NOT use a power grease gun to lubricate bearings. These require very small and exact amounts of lubrication. Refer to the detailed maintenance section for specific lubrication instructions. DO NOT over-grease bearings.
- Be alert to maintenance indicators such as the in-tank filter pressure gauge, hydraulic reservoir sight gauge, etc. Take the required action to correct any problems immediately.
- Release of energy from pressurized systems may cause inadvertent actuation of cylinders, or sudden release of compressed springs. Before disconnecting any hoses relieve pressure by shutting tractor off, setting cutter on ground and actuating lift valve handles.



**WARNING** DO NOT use hands to check for suspected leaks in hydraulic hoses! Hydraulic fluid escaping under pressure can have sufficient force to penetrate skin and cause serious injury. If fluid is injected into skin, it must be surgically removed within a few hours or gangrene may result. Use a small piece of wood or cardboard, not hands, to search for pin hose leaks. Be sure all connections are tight and hoses and lines are not damaged before applying pressure.

## Break in Period

In addition to following the break in instructions for your particular tractor, the in-tank hydraulic fluid filter should be replaced after the first 50 hours of service. Thereafter the filter should be replaced every 500 hours, or yearly, whichever comes first.

Re-torque wheel lugs after first five hours of operation and periodically thereafter. See torque specifications listed in the tractor's service manual for your particular model. **Wheel lugs must always be re-torqued whenever a wheel is removed and reinstalled.**



**DANGER** Never work under the Implement, the frame, or any lifted component unless the Implement is securely supported or blocked up to prevent sudden or inadvertent falling which could cause serious injury or even death. (SG-14)



**WARNING** Do not modify or alter this Implement. Do not permit anyone to modify or alter this Implement, any of its components or any Implement function. (SG-8)

# MAINTENANCE

## **WARNING**

Relieve hydraulic pressure prior to doing any maintenance or repair work on the Implement. Place the Mower Head on the ground or securely supported on blocks or stands, disengage the PTO, and turn off the engine. Push and pull the control Levers or Joystick several times to relieve pressure prior to starting any maintenance or repair work. (SBM-6)

## **DANGER**

Always disconnect the wire leads from the mower pump solenoid before performing service on the Tractor or Mower. Use caution when working on the Tractor or Mower. Tractor engine must be stopped before working on Mower or Tractor. The Mower Blades could inadvertently be turned on without warning and cause immediate dismemberment, injury or death. (SBM-12a)

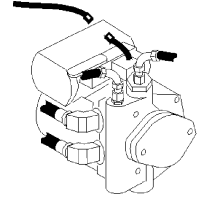

**MAINTENANCE**

# MAINTENANCE

## Regular Maintenance

The intervals at which regular servicing should be done are based on hours of operation. Use the tractors hour meter to determine when regular servicing is required.

Refer to the Detailed Maintenance section for further instructions on greasing. Copy and use the Daily Maintenance sheet located at the end of this section.

### Daily or Every 8 Hours

ITEM	SERVICE	COMMENTS
Drive Shaft Yoke, U-Joint & Stub Shaft	Grease	Grease as instructed in detailed maint. section
Pump Drive•haft Coupler	Check and Lube	Insure driveshaft end play
Crankshaft Adapter	Check rubber grommets	Replace grommets if damaged or missing
Pivot Points	Lubricate	Inject grease until it appears at end
Hydraulic Fittings	Check for leaks	Tighten when needed. Do Not use hands to check for leaks, see maint. ] recautions
Knives	Check	Inspect for missing or damaged knives, change as needed.
Spindle mouting bolts (spindle to deck)	Check	Torque to 331ft. lbs. lubricated Torque to 357ft. lbs. dry
Knife mounting bolts (knife to disk or blade bar)	Check	Pre-lubricate threads, then torque to 800 ft. lbs.
Disk/Blade Bar mounting bolts (disk/blade bar to spindle)	Check	Torque to 184ft. lbs. lubricated Torque to 180ft. lbs. dry
Belts	Check/Adjust	Check if broken, tighten as required
Main Frame and Deck	Check	Retorque bolts to torque specifications in this section
Hydraulic Fluid Level	Check	Add if required per fluid recommendations
Rear Flail Drive(if applicable) Bear Flange and Shaft Coupler	Lubricate	Grease as instructed in detailed maint. section
Cutter Shaft and Ground Roller	Lubricate	Grease as instructed in detailed maint. section

RSS

Maintenance Section 4-4

MAINTENANCE



# MAINTENANCE

## WEEKLY OR EVERY 40 HOURS

ITEM	SERVICE	COMMENTS
Rotary Spindle	Lubricate	Every 40 hours or weekly

## WEEKLY OR EVERY 50 HOURS

ITEM	SERVICE	COMMENTS
In Tank Hyd. Fluid Filter <b>(10 micron filter)</b>	Change	Change after first 50 hours only, then every 500 hours or yearly
In-Line High Pressure Filter <b>(10 micron filter)</b>	Change	Change after first 50 hours only, then every 500 hours or yearly

## MONTHLY OR EVERY 150 HOURS

ITEM	SERVICE	COMMENTS
Hydraulic Fluid Level	Check	Add as needed
Hyd. Tank Breather	Clean/Check/Replace	Clean or replace Element as required
Rear Tire Type	Max P.S.I.	
480/80R38	29	
18.4-34	26	
18.4-38	26	

## YEARLY OR EVERY 500 HOURS

ITEM	SERVICE	COMMENTS
Spindle Grease	Change	
Hyd. Tank Fluid	Change	
In Tank Hyd. Fluid Filter <b>(10 micron filter)</b>	Change	
In-Line HP Filter <b>(10 micron filter)</b>	Change or	Change when indicated by restriction indicator.
Hyd. Tank Breather	Change	

# MAINTENANCE

## TROUBLESHOOTING

SYMPTOMS	CAUSE	REMEDY
<b>Vibration</b>	1. Loose Bolts	1. Check all bolts and tighten to recommended torque specs.
	2. Cutter assembly Unbalanced	2a. Check for damage blades, disc or cuttershaft. Replace if needed. 2b. Check for wire, rope, etc. entangled in the cutter assembly
<b>Mower will not lift</b>	1. Hyd. Fluid Low	1. Check and refill @d fluid
	2. Leaks in line ROU 3. Faulty relief valve	2. Tighten or replace fittings and hoses 3. Check pressure in line. Line pressure in Control Valve should be at least 2500 P.S.I.
	5. Faulty cylinder	5. Inspect, repair or replace cylinder
<b>Mower will not start or run</b>	1. Blown fuse	1. Check fuse between mower switch and ignition/replace
	2. Ball valves closed	2. Make sure valves are open
	3. Low oil level	3. Check Hyd. tank and fill
	4. Line leak	4. Check all fittings and lines, re-tighten or replace
	5. Electronic solenoid faulty	5a. Without the tractor running, turn the mower switch to on. A low audible click should be heard if the solenoid is engaging the solenoid spool. If click is not heard, leave switch in on position and with a screwdriver or other steel object, touch the small nut on the end of the solenoid. If the metallic object is not attracted to the nut, check the fuse and wiring for an open circuit. If the object is attracted but no "click" is heard, replace the solenoid. 5b. Remove the four bolts holding the small block to the main block. Lift and remove small block being careful not to damage O-rings/filter. Clean filter and re-install. 5c. Remove large nut on side of large valve block. Remove spring, and use needle nose vise grip to pull spool from block. Check block and spool for contaminates and scratches. Clean parts or replace if scratched.

MAINTENANCE

# MAINTENANCE

## TROUBLESHOOTING (CONTINUED)

SYMPTOMS	CAUSE	REMEDY
<b>Motor runs but will not cut.</b>	<ol style="list-style-type: none"> <li>1. Belts</li> <li>2. Tensioner</li> </ol>	<ol style="list-style-type: none"> <li>1. Inspect belts and pulleys. Replace belts and repair as needed.</li> <li>2. Adjust tensioner nuts tension should be 106 freq cyl/sec.</li> </ol>
<b>Mower turns slowly or not at all.</b>	<ol style="list-style-type: none"> <li>1. Contaminants restricting spool movement in valve body.</li> <li>2. Suction lines obstructed</li> <li>3. Low oil level</li> </ol>	<ol style="list-style-type: none"> <li>1. Remove large nut on side of large valve block. Remove spring, and use needle nose vise grip to pull spool from block. Check block and spool for contaminants and scratches. Clean parts or replace if scratched.</li> <li>2. Check for kinks or obstructions in suction hose.</li> <li>3. Check @d. tank level and fill.</li> </ol>
<b>Pump will not work</b>	<ol style="list-style-type: none"> <li>1. Excessive wear on internal parts</li> </ol>	<ol style="list-style-type: none"> <li>1. Disassemble and repair.</li> </ol>
<b>Motor will not work</b>	<ol style="list-style-type: none"> <li>1. Excessive wear on internal parts</li> </ol>	<ol style="list-style-type: none"> <li>1. Disassemble and repair.</li> </ol>

NOTE: If flow meter is available, check pressure and flow volume for all suspected hydraulic problems.

If the solution to your problem cannot be found in this section, call the Technical Service representative at the number shown on the front cover of this manual.

**MAINTENANCE**

# MAINTENANCE

MAINTENANCE

## TORQUE SPECIFICATIONS

Torque for Standard Fasteners													
Nominal Dia. (in.)	threads per inch	Grade 2			Grade 5			Grade 8			Grade 9		
		Tightening Torque			Tightening Torque			Tightening Torque			Tightening Torque		
		Lubed K = 0.15	Dry Plated K = 0.17	Dry plain K = 0.20	Lubed K = 0.15	Dry Plated K = 0.17	Dry plain K = 0.20	Lubed K = 0.15	Dry Plated K = 0.17	Dry plain K = 0.20	Lubed K = 0.15	Dry Plated K = 0.17	Dry plain K = 0.20
Unified Coarse Thread Series													
1/4	20	49 in-lbs	59 in-lbs	66 in-lbs	76 in-lbs	86 in-lbs	101 in-lbs	107 in-lbs	122 in-lbs	143 in-lbs	126 in-lbs	143 in-lbs	168 in-lbs
5/16	18	101	122	135	157	178	209	221	251	295	259	294	346
3/8	16	15 ft-lbs	18 ft-lbs	20 ft-lbs	23 ft-lbs	26 ft-lbs	31 ft-lbs	33 ft-lbs	37 ft-lbs	44 ft-lbs	38 ft-lbs	43 ft-lbs	51 ft-lbs
7/16	14	24	29	32	37	42	49	52	59	70	61	70	82
1/2	13	37	44	49	57	64	75	80	90	106	94	106	125
9/16	12	53	63	70	82	92	109	115	130	154	135	153	180
5/8	11	73	87	97	113	128	150	159	180	212	186	211	248
3/4	10	129	155	172	200	227	267	282	320	376	331	375	441
7/8	9	125	150	167	322	365	429	455	515	606	533	604	710
1	8	187	225	250	483	547	644	681	772	909	799	905	1065
1 1/8	7	266	319	354	596	675	794	836	966	1132	988	1132	1341
1 1/4	7	375	450	500	840	952	1121	1163	1345	1545	1345	1545	1830
1 1/2	6	652	783	869	1462	1657	1950	2011	2311	2688	2311	2688	3206
Fine Thread Series													
1/4	28	56 in-lbs	68 in-lbs	75 in-lbs	87 in-lbs	99 in-lbs	116 in-lbs	123 in-lbs	139 in-lbs	164 in-lbs	144 in-lbs	163 in-lbs	192 in-lbs
5/16	24	112	135	150	174	197	231	245	278	327	287	325	383
3/8	24	17 ft-lbs	20 ft-lbs	23 ft-lbs	26 ft-lbs	30 ft-lbs	35 ft-lbs	37 ft-lbs	42 ft-lbs	49 ft-lbs	43 ft-lbs	49 ft-lbs	58 ft-lbs
7/16	20	27	32	36	41	47	55	58	66	78	68	78	91
1/2	20	41	49	55	64	72	85	90	102	120	105	120	141
9/16	18	59	71	78	91	103	121	128	146	171	151	171	201
5/8	18	82	99	110	127	144	170	180	204	240	211	239	281
3/4	16	144	173	192	223	253	297	315	357	420	369	418	492
7/8	14	138	165	184	365	403	474	502	588	669	588	666	784
1	14	210	252	280	542	614	722	765	867	1020	896	1016	1195
1 1/8	12	298	357	397	668	757	890	1083	1227	1444	1269	1439	1693
1 1/4	12	415	498	553	930	1055	1241	1509	1710	2012	1768	2004	2358
1 1/2	12	734	880	978	1645	1865	2194	2668	3024	3557	3127	3544	4169

Torque values for 1/4 and 5/16 in series are in inch-pounds. All other torque values are in foot-pounds. K = 0.15 for "lubricated" conditions; D = Nominal Diameter  
 Torque values calculated from formula T=KDF, where K = 0.17 for zinc plated and dry conditions; F = Clamp Load  
 K = 0.20 for plain and dry conditions

Torque-Tension Relationship for Metric Fasteners													
Nominal Dia. (mm)	Pitch	Class 4.6			Class 8.8			Class 10.9			Class 12.9		
		Tightening Torque			Tightening Torque			Tightening Torque			Tightening Torque		
		Lubed K = 0.15	Dry Plated K = 0.17	Dry plain K = 0.20	Lubed K = 0.15	Dry Plated K = 0.17	Dry plain K = 0.20	Lubed K = 0.15	Dry Plated K = 0.17	Dry plain K = 0.20	Lubed K = 0.15	Dry Plated K = 0.17	Dry plain K = 0.20
3	0.5	0.28	0.32	0.38	0.73	0.82	0.97	1.0	1.2	1.4	1.2	1.8	
3.5	0.6	0.44	0.50	0.59	1.1	1.3	1.5	1.6	1.9	2.2	1.9	2.5	
4	0.7	0.66	0.74	0.87	1.7	1.9	2.3	2.4	2.7	3.2	2.8	3.8	
5	0.8	1.3	1.5	1.8	3.4	3.9	4.5	4.8	5.5	6.5	5.7	7.6	
6	1	2.3	2.6	3.0	5.8	6.6	7.7	8.3	9.4	11	9.7	13	
6	1.25	2.1	2.3	2.7	5.3	6.0	7.0	7.6	8.6	10	8.6	12	
7	1	3.8	4.3	5.0	9.7	11	13	14	16	19	16	22	
8	1	5.8	6.6	7.8	15	17	20	22	24	29	25	34	
8	1.25	5.5	6.2	7.3	14	16	19	20	23	27	24	31	
10	1.25	11	13	15	29	33	39	42	48	56	49	66	
10	1.5	11	12	14	28	32	37	40	45	53	47	62	
12	1.25	21	23	28	53	60	71	76	86	101	89	119	
12	1.5	20	22	26	51	58	68	73	82	97	85	113	
12	1.75	19	21	25	49	55	65	70	79	93	81	108	
14	1.25	26	29	34	66	75	89	95	108	127	111	148	
14	1.5	28	32	37	72	82	96	103	117	138	121	161	
14	2	30	34	40	78	88	104	111	126	148	130	173	
16	1.5	50	57	67	129	146	171	184	208	245	215	287	
16	2	47	53	62	121	137	161	173	196	230	202	269	
18	1.5	73	82	97	187	212	249	268	303	357	313	417	
18	2.5	65	73	86	167	189	222	239	270	318	279	372	
20	1.5	101	115	135	270	306	360	374	424	498	437	583	
20	2.5	91	104	122	238	267	314	337	382	449	394	525	

Clamp load calculated as 75% of the proof load for specified bolts. K = 0.15 for "lubricated" conditions; D = Nominal Diameter  
 All torque values are listed in foot-pounds; K = 0.17 for zinc plated, dry conditions; F = Clamp Load  
 Torque values calculated from formula T=KDF, where K = 0.20 for plain and dry conditions

Maintenance Section

# MAINTENANCE

## LUBRICATION RECOMMENDATIONS

**MAINTENANCE**

Description	Application	General Specification	Recommended Mobil Lubricant
Tractor Hydraulics	Reservoir	JD-20C MF M1135,M1141 FNHM2C134D (FNH201)	Mobilfluid 424
Mower Hydraulics Cold Temperatures 0° F Start-Up	Reservoir	ISO 46 Anti-Wear-Low Temp	Mobil DTE 15M
Normal Temperatures 10° F Start-Up		JD-20C MF M1135,M1141 FNH M2C134D(FNH201)	Mobilfluid 424
Normal Temperatures 15° F Start Up		ISO 46 Anti-Wear	Mobil DTE 25
High Operating Temp. Above 90° F		ISO 100 Anti-Wear	Mobil DTE 18M
Flail Rear Gearbox	Grease	PAO Synthetic Extreme Pressure Gear Lube	Mobil SHC 75W-90 Mobil 1 Synthetic Gear
Cutter Shaft & Ground Roller Shaft(Flail)	Grease Gun	Lithium-Complex Extreme Pressure NLGI-ISO 320	Mobilgrease CM-S
Drive Shaft Coupler (Flail and Rotary)	Grease Gun	Lithium-Complex Extreme Pressure NLGI2-ISO 320	Mobilgrease CM-S
Drive Shaft Yoke, U-joint & Stub Shaft	Grease Gun	Lithium-Complex Extreme Pressure NLGI2-ISO 320	Mobilgrease CM-S
Boom Swivel Boom Cylinder Pivots (Rotary & Flail Boom)	Grease Gun	Lithium Complex Extreme pressure NLGI2-ISO 320	Mobilgrease CM-S
Deck Boom Pivot & Deck Stop Adjustment Rotary & Flail)	Grease Gun	Lithium Complex Extreme Pressure NLGI-ISO 320	Mobilgrease CM-S
Deck Spindle(Rotary)	Grease Gun	Tiger Spindle Lubricant part number 06540000	Mobilith SHC 220

RSS

Maintenance Section 4-9

# MAINTENANCE

MAINTENANCE

## GRAFFITI REMOVAL

Butyl cellosolve (for removal of paints, marking pen inks, lipstick, etc.) The use of masking tape, adhesive tape or lint removal tools work well for lifting off old weathered paints.

To remove labels, stickers, etc., the use of kerosene or VM&P naphtha are generally effective. When the solvent will not penetrate sticker material, apply heat (hair dryer) to soften the adhesive and promote removal.

IMPORTANT: If a material is found to be incompatible in a short-term test, it will usually be found to be incompatible in the field. The converse, however, is not always true. Favorable performance is no guarantee that actual end-use conditions have been duplicated. Therefore, these results should be used as a guide only and it is recommended that the user test the products under actual end-use conditions.

## RECOMMENDED FILLING INSTRUCTIONS FOR HYDRAULIC RESERVIORS

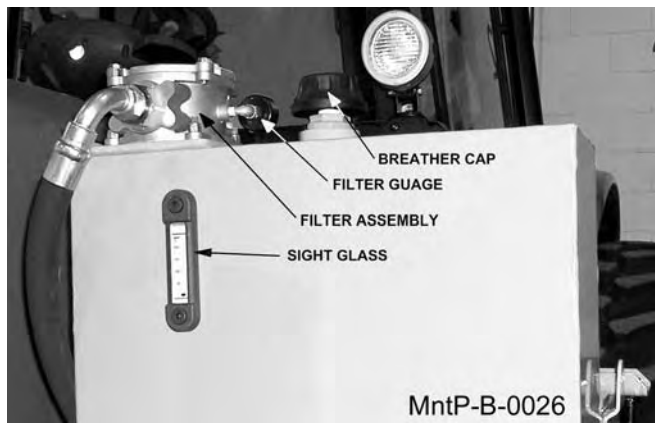

The reservoir should be filled to the center of the sight glass on the side of the tank. Do not over-fill. If the tank has too much oil, the excess may be expelled through the pressurized breather.

## DETAILED MAINTENANCE

### REPLACING IN-TANK HYDRAULIC FILTER:

Loosen the four bolts on the top cover of the filter housing. Turn cover counter-clockwise until cover is free. Remove and replace filter. Replace top cover and cover bolts in opposite order as removed.



# MAINTENANCE

## DETAILED MAINTENANCE

### REPLACING HIGH PRESSURE HYDRAULIC FILTER ELEMENT:

Ensure system has been shut down and depressurized. Locate High Pressure Filter housing. Confirm that the element that is about to be installed matches the element p/n on the filter model tag. Example: V3.0510-06 (world line 100, HD049 model) Locate the bottom of the High Pressure Bowl. Use the appropriate spanner wrench or ratchet and turning in a counterclockwise rotation, (looking at the bottom of the bowl) remove the bowl from the head. The first couple rotations will seem tight as the o-ring passes the sealing flats. Once the o-ring has cleared the sealing flats the bowl should spin freely. Taking care not to drop the bowl, finish removing the bowl from the head. **WARNING:** bowl will be full of oil! Pour the oil from the bowl into a container. This oil should be considered contaminated and disposed of properly. Note the flow direction through the element is outside-in. Clean the inside of the bowl if dirt is present. Remove the old element from the filter head by pulling with a rotation motion. Dispose of the used element properly. Remove the new element from the packaging. Using your finger, dab and lubricate the o-ring in the top of the new element. Install the new element into and on the mounting boss within the head. Ensure that the element is fully seated on the boss. Clean and inspect the o-ring that is affixed in the bowl, lubricate with oil. Using a clockwise rotation, screw the bowl back into the head, ensuring that the bowl has not been cross threaded into the head. Continue to tighten the bowl into the head, using the spanner wrench or ratchet. The rotation of the bowl will become tighter once the o-ring engages the sealing flats. Once the bowl has bottomed out, "back-off" the bowl by 1/6 turn, this ensures that the o-ring is seated properly within the sealing flats. Element change out and re-assembly is now complete. Start the machine and inspect the filter area checking that there is no oil leaking from the filter assembly. This is first to be done at 50 hours of operation, then yearly (500 hours) or when indicated by restriction indicator.

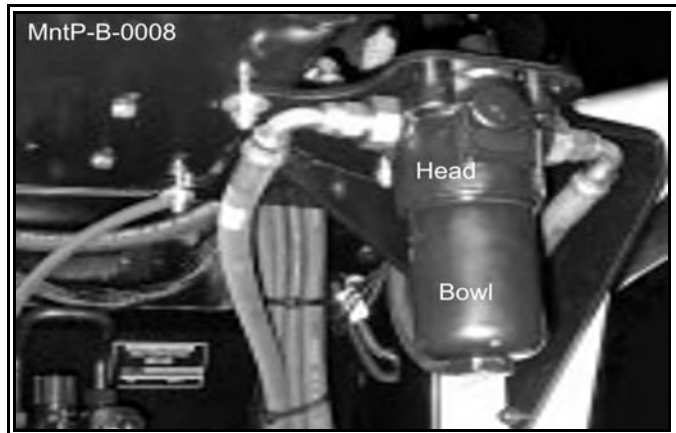

MAINTENANCE

### GREASING CUTTER SHAFT-FLAIL MOWERS

Locate grease zerks on each end of cutter shaft(s), these are located on the bearing cover. Normal conditions require one or two pumps in each bearing, using Lithium-Complex Extreme Pressure grease conforming to NLGI2-ISO 320 specifications. This is to be done with a standard grease gun daily or at **8 hour intervals**. **CAUTION: Over greasing may cause premature seal failure.**

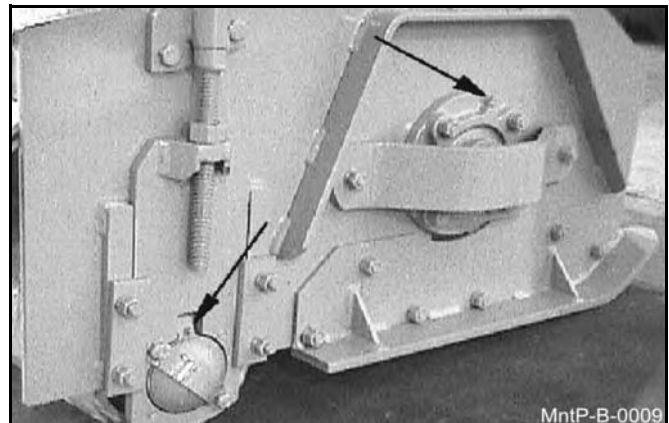

# MAINTENANCE

MAINTENANCE

## GREASING GROUND ROLLER SHAFT-FLAIL

Locate grease zerks on each end of roller tube at lower end of head. Normal conditions require one or two pumps in each bearing, using Lithium-Complex Extreme Pressure grease conforming to NLGI2-ISO 320 specifications. This is to be done with a standard grease gun daily or at **8 hour intervals**. **CAUTION: Over greasing may cause premature seal failure.**



## TIGHTENING KNIFE BOLTS AND DISK BOLTS:

After every 8 hours of operation or daily, the Knife Bolts and Disk Bolts should be tightened as follows:

Knife mounting bolts torque to 800 oiled ft. lbs.

Disk mounting bolts (6ea.) torque to 204 dry or 180 oiled ft. lbs.





# MAINTENANCE

MAINTENANCE

## GREASING POINTS ON BOOM AND PIVOT

Locate grease zerks on deck pivot assembly, on the deck end of the boom, and at swivel end of main boom. Inject Lithium-Complex Extreme Pressure grease conforming to NLGI2-ISO 320 specifications until grease begins to protrude from ends.

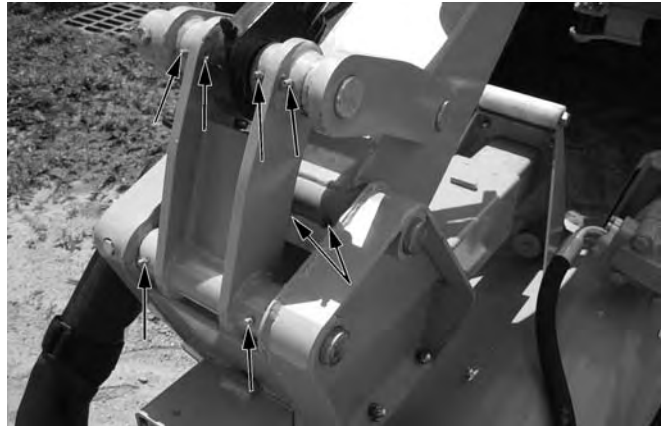

## GREASING SPINDLE

Locate grease fitting on inside of deck housing. Inject Tiger Spindle Lubricant, part number 06540000 into spindle housing. Fill with lubricant until lubricant weeps out of top spindle seal. Lubricate spindle weekly or every 40 hours of use.



# MAINTENANCE

## TIGHTENING SPINDLE BOLTS

The spindle mounting bolts should be checked and retorqued daily or every 8 hours of service. Torque the (6) bolts shown below to 357 dry or 315 ft. lbs. lubricated.

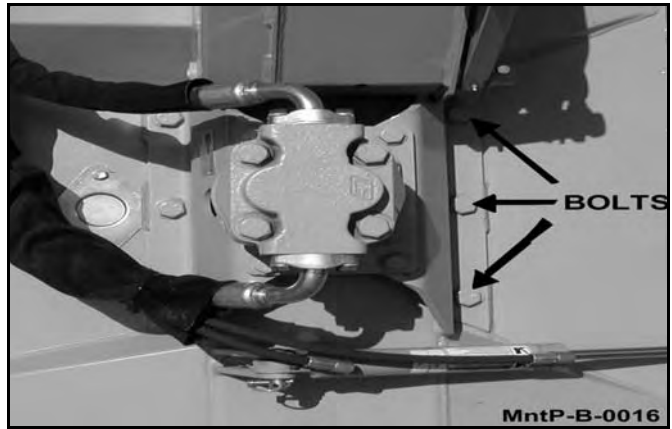

## GREASING PUMP DRIVESHAFT COUPLER

With engine stopped, ensure driveshaft alignment by grasping coupler and sliding back and forth. Coupler should slide freely with approximately 1/8" of end play. If coupler does not slide freely, inspect for loose pump mount bolts, or damaged or loose crank•@ec adapter. Inject Lithium-Complex Extreme Pressure grease conforming to NLG12-ISO 320 specifications into coupler until grease begins to protrude from ends. Grease daily or every 8 hours. Do not over grease.



# MAINTENANCE

MAINTENANCE

## DRIVE SHAFT YOKE, U-JOINT STUB SHAFT

With engine stopped, inject Lithium-Complex extreme pressure grease conforming to NLGI2-ISO 320 specifications into universal joints and slip yoke until grease appears at the seal. Grease them daily or every 8 hours.

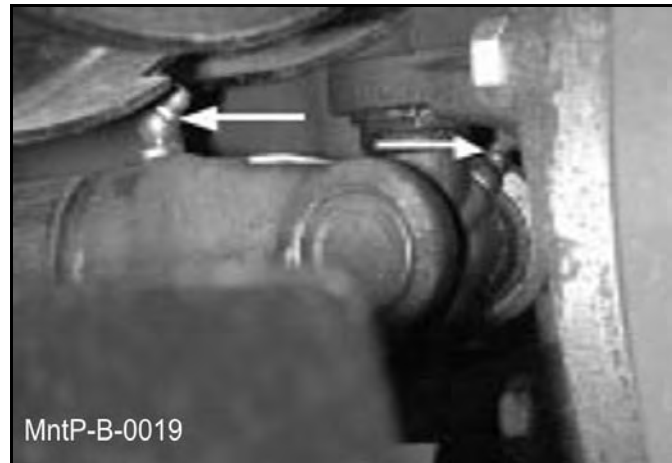
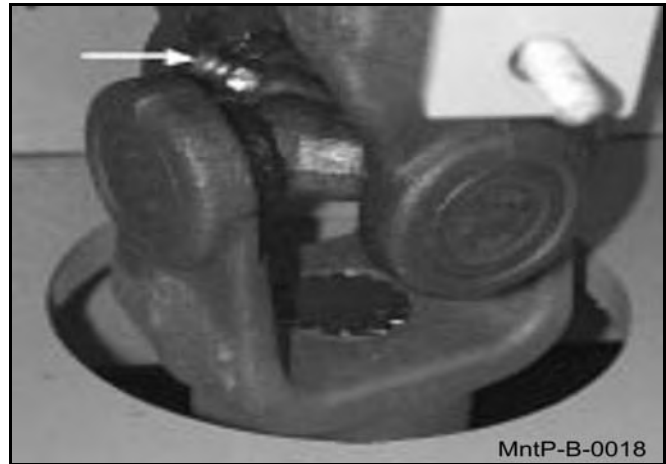

## GREASING THE BOOM SWIVEL

Locate the zerks on the main swivel boss (if applicable), main boom pivot boss (if applicable) and on both ends of the boom swivel cylinder. Inject Lithium-Complex Extreme Pressure grease conforming to NLGI2-ISO 320 specification until grease begins to protrude from ends.

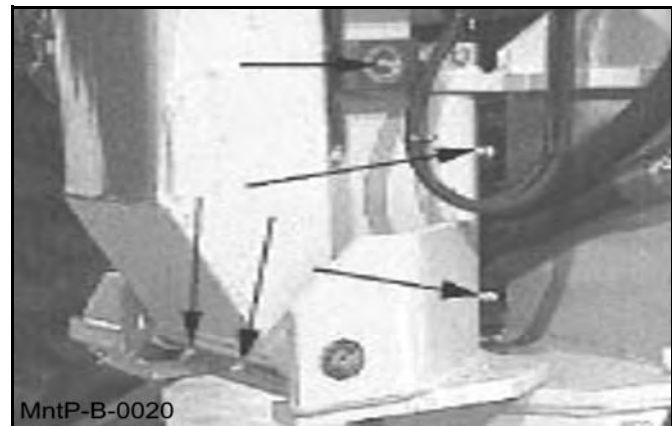

# MAINTENANCE

MAINTENANCE

## GREASING BOOM CYLINDER(S) PIVOT POINTS

Locate the zerk on the butt end tang of cylinder and on rod end tang. Inject Lithium-Complex Extreme Pressure grease confirming to NLGI2- ISO 320 specifications until grease begins to protrude from ends. This procedure is to be used on the main boom cylinder, secondary boom cylinder, deck pivot, and swivel cylinders daily or at 8 hour intervals.

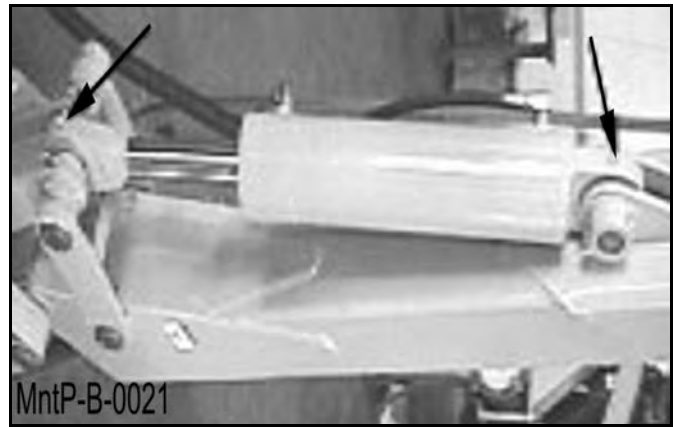

## BALL VALVES

The ball valve at the hydraulic reservoir may need to be closed during certain maintenance or repair procedures. **THE BALL VALVES MUST BE OPEN (handle parallel with valve) WHEN TRACTOR IS RE-STARTED OR PUMP IS COUPLED TO MOTOR OR PTO!** Failure to do so will result in component failure!

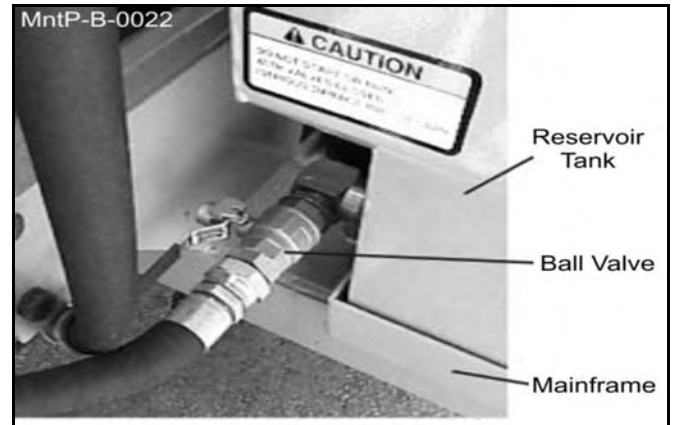

# MAINTENANCE

MAINTENANCE

## BELT TENSION ADJUSTMENT

Locate the tensioning rod for the flail. Loosen the top tension adjustment nut. To tighten the belt, turn the bottom tension nut to compress the spring. To loosen the belt tension, turn the tension nut up to relax the spring. After adjustment, test the belt tension.

The tension should be 207Lbf or 106 freq cyl/sec. If the tension is as desired, turn the top tension nut down to lock the bottom tension nut into place.

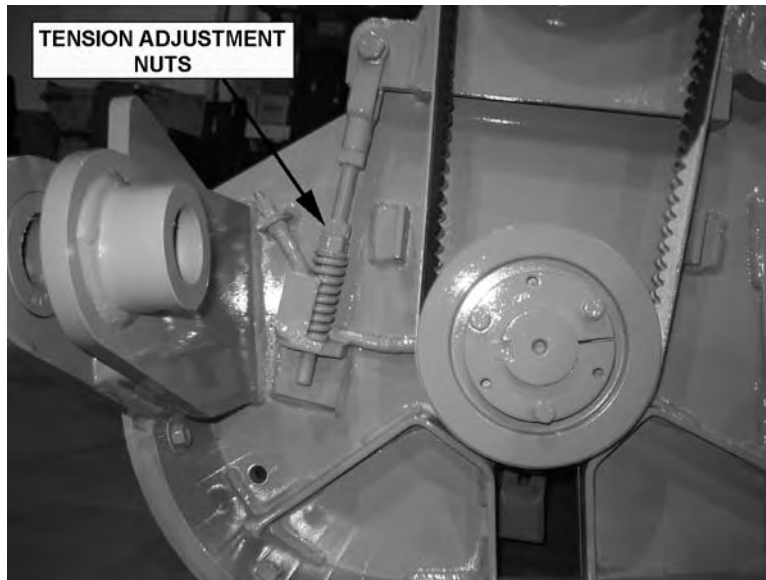

## ADJUSTING RSS FLAIL CUT HEIGHT

To adjust the cutting height of the Rear Side Stow flail head the two nuts on the roller shaft brackets must be taken off and moved to the desired location/height. Be sure that both sides of the shaft are adjusted to corresponding holes so the shaft remains level.

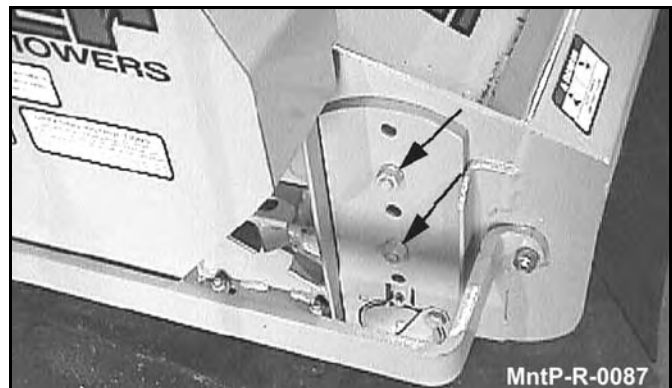

# MAINTENANCE

## REVERSING MOWER ROTATION OF RSS FLAIL MOWERS

To reverse the rotation of the Rear Side Stow flail, you need to switch the pressure and return motor hoses at the brake valve. Make sure the tractor is shut off and the ball valve is closed. Relieve the hydraulic pressure in the system first before removing any hoses. After switching the hoses, make sure you open the ball valve or serious damage can be done to the hydraulic pump.

When operating in standard rotation, the front shield must be removed and the baffle installed. When operating in reverse rotation, remove the baffle and install the front shield. Finally, reposition the wear pads on the hoses and replace the zip ties as needed to prevent the hydraulic hoses from rubbing or chafing.

MAINTENANCE

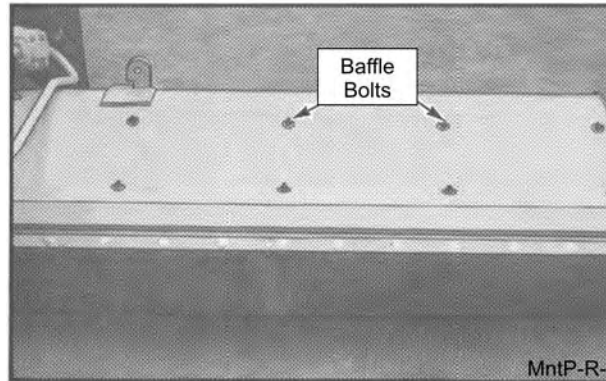
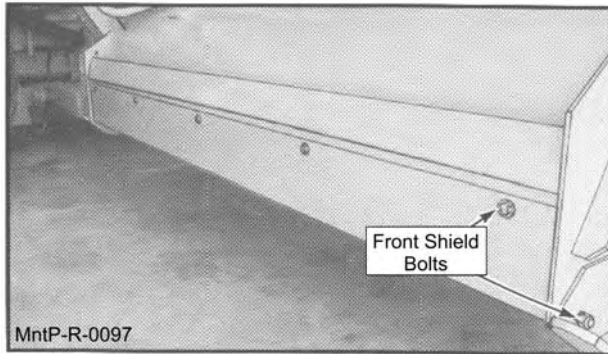

# MAINTENANCE

## Blades

Check the Blades for cracks and wear and Blade Bolts for tightness, daily. Blades should be replaced when they are worn excessively, bent, deformed, or out of balance.

### CAUTION

Blades should always be replaced in pairs. Blades of different weights can cause serious imbalance and damage to the machine and personnel. When replacing blades, take care to replace the blade bolts, nuts, and washers.

### Important

Make sure the mower blades are turning clockwise when looking down from the top of the mower. Follow the color coding on the hydraulic hoses and fittings to make sure the motor and hydraulics hoses are assembled properly. Connect the red hose connection only to red fitting. Connect the blue hose connection only to the blue fitting. The blade rotation on the leading edge of the mower should discharge the cut material away from the tractor and operator.

### WARNING

If the leading edge of the mower blades are rotating backwards they can discharge material toward the operator. If this occurs discontinue mowing immediately and reverse the direction of the motor rotation by correctly installing the motor pressure and return hoses. Contact your dealer or Alamo Industrial for specific information on the hose routing.

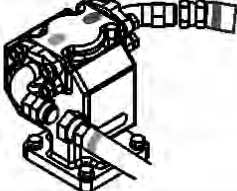

MAINTENANCE

<b>WARNING</b>	<b>ADVERTENCIA</b>
<b>TO AVOID SERIOUS INJURY AND DEATH FROM THROWN OBJECTS:</b> <ul style="list-style-type: none"><li>• MAKE CERTAIN blades rotate the correct direction.</li></ul>	<b>PARA EVITAR LESION SERIA O MUERTE POR OBJETOS LANZADOS:</b> <ul style="list-style-type: none"><li>• ASEGURE que las cuchillas giran en la dirección correcta.</li></ul>
<b>BLADE ROTATION</b>  <b>ROTACIÓN DE CUCHILLAS</b>	
Return Retorno <b>BLUE</b>	 Pressure Presión <b>RED</b>

D619

# MAINTENANCE

## ROTARY KNIFE REPLACEMENT

1. Be sure you have a complete matching set of new knives for replacement.
2. Remove knives and inspect holes for damage. Also watch for cracks in the disk (if applicable) around the holes.
3. Lube threads with anti-seize. Install bolts through knife and disk from bottom side of disk/blade bar. Install new self-locking nuts and torque them to 800 ft. lbs.
4. The knives should swing freely to absorb shocks from impact when striking objects.



**WHEN CUTTING HEAVY BRUSH, KNIFE BOLTS SHOULD BE INSPECTED HOURLY AND RETORQUED TO 1070 DRY OR 800 OILED FT. LBS.**

## REPLACEMENT OF ROTARY DISK



**Failure to follow the following warnings and instructions may result in serious injury or damage to the equipment or property!**

1. The bolts that attach the disk to the spindle must be grade 8. These 5/8 inch bolts are to be torqued to 204 dry or 184 oiled ft. lbs.
2. A thread locking agent may be applied to threads of all mounting bolts before they are installed.
3. **Disks must be inspected daily for hairline cracks between spindle mounting bolts or around the knife mounting bolts. These cracks indicate metal fatigue caused by severe abuse. If cracks are present the disk must be replaced.**
4. Inspect the disk mounting bolts daily when checking tightness of knife mounting bolts. If a disk mounting bolt is loose, it must be removed, threads cleaned, fresh thread locking agent applied, and tightened to proper torque value.
5. If a knife mounting bolt is loose, the self locking nut must be replaced as a safety precaution. Lubricate threads with anti-seize. Install bolts through knife and disk/blade bar from bottom side. Install self locking nuts and torque them to 800 ft. lbs.



# MAINTENANCE

## Flail Blades Inspection



Inspect the Blades daily for ab normal wear. REPLACE ALL BLADES on the carrier IMMEDIATELY if any blades have:

- Become bent or deformed from its original shape, or
- Wear inside the blade bolt hole, or
- Any cracks are visible, or
- Deep gouges in the blade's surface are present, or
- Gouges or chipped areas in the cutting edge are larger than 1/4"(8mm), or
- The material on the leading edge has been worn away by more than 1/4"(8mm)

**DO NOT** straighten, sharpen, weld or hard-face blades

Failure to replace worn or damaged blades may lead to catastrophic failure of the blades and ejection of the broken part with tremendous force which may cause serious bodily injury or death.

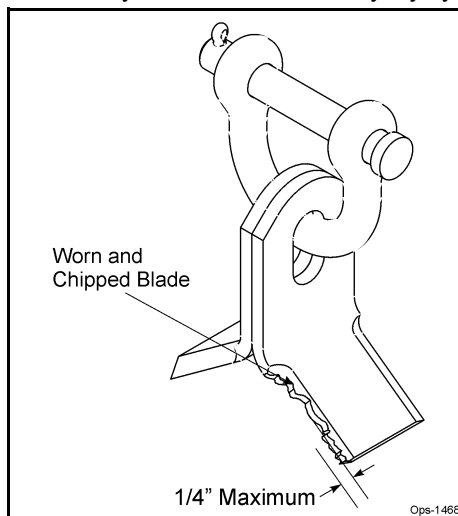

Always replace blades in sets

- Blades that are damaged may indicate severe service or abuse. If one blade is worn or damaged other blades on the same shaft will have been subjected to the same severe service or abuse.
- The Flail rotor turns at speeds exceeding 2000 RPM and is dynamically balanced at the factory. Differences in blade weight between used blades with loss of material from gouges or wear as compared to new blades can cause severe vibration and damage to the Flail rotor. Always replace blades as complete sets.



Use only genuine Alamo Industrial replacement blades and fasteners. Other blades and fasteners may not meet the Alamo Industrial requirements and could fail during operation resulting in part being thrown out from under the mower.



Never attempt to sharpen blades. OPS-U-0044

# MAINTENANCE

## Blade Pins and D-Ring Inspection

Blade Pins and D-Rings daily for wear or damage as follows:



Inspect the Blade pins and D-Rings daily for abnormal wear. Make sure the cotter pins are in place and properly spread. REPLACE BLADE Pins and D-Rings IMMEDIATELY if they have:

- Visible cracks or
- If a Pin or D-Ring has visible worn areas, or
- If a Pin or D-Ring has gouges or chipped areas

Failure to replace abnormally worn pins or D-Rings may lead to catastrophic failure and ejection of the broken part which may cause serious bodily injury or death.

Always replace the pins and D-Rings whenever excessive wear is noticed.

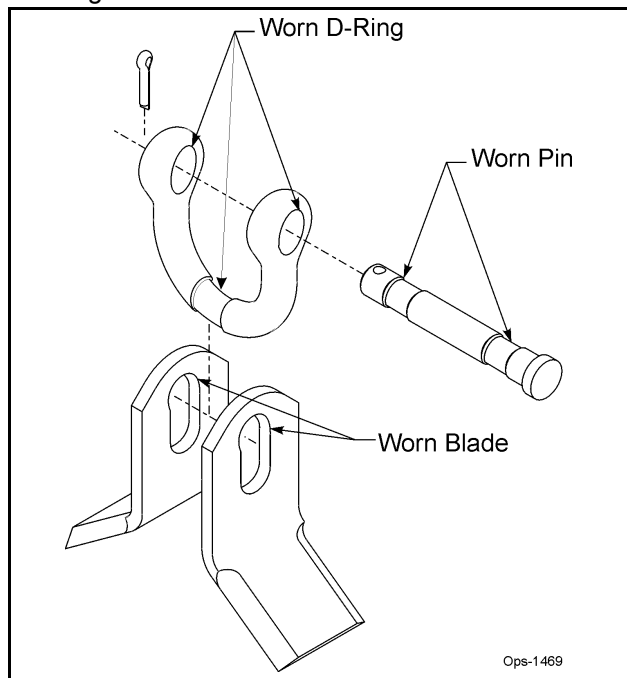

### **Important**

If the cotter pins are broken by contact with other flail blades, remove the pin and reverse the direction the pin is inserted through the D-Ring so that the cotter pin is on the opposite side of the D-Ring. This will prevent the next set of blades from swinging back and hitting the cotter pin. OPS-U-0045

# MAINTENANCE

## BOOM FLAIL KNIFE REPLACEMENT

1. If knives are damaged or badly worn, they will need to be replaced as a set. Replacing a single knife can cause severe vibration and possible damage to the mower.
2. Assemble knives, clevis, bolts and nuts as shown in part section of manual.
3. Install locking hex nut so that the flat face of nut is towards the knife.
4. Apply loctite "271" or equivalent to threads.
5. Torque nut to 35 FT. LBS. Knife must swing freely.



**DO NOT re-use the locking hex nuts for mounting the knives. If hex nut become loose, or require removal for knife replacement or any other reason, they must be discarded and replaced with new nuts.**



**Knives should not be welded on for any reason.**

# MAINTENANCE

## THE SPINDLE ASSEMBLY

See the diagram below for identification of spindle parts, while servicing.

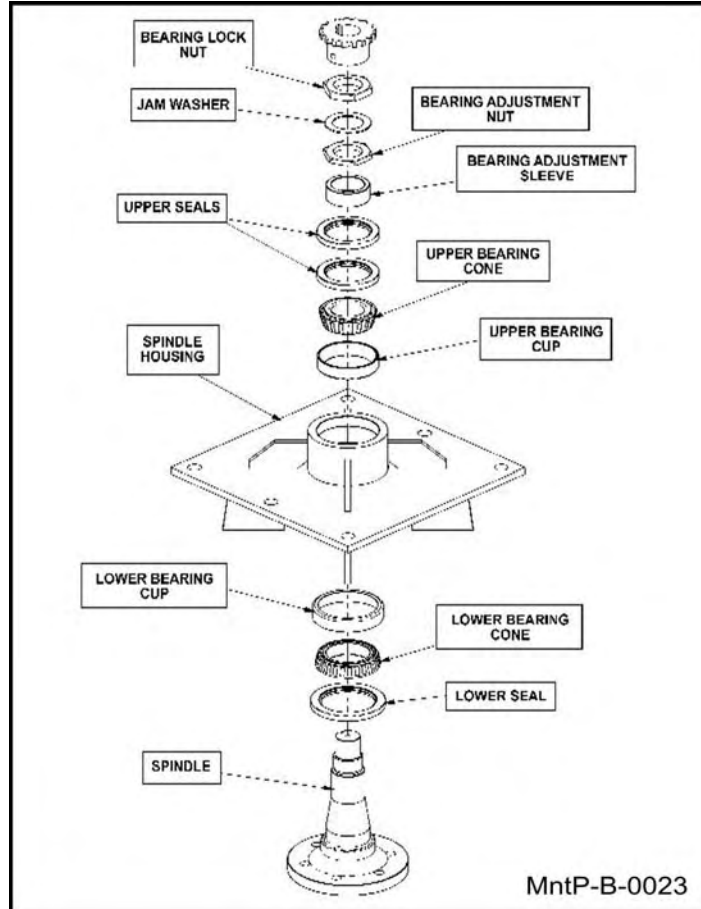

MAINTENANCE

# MAINTENANCE

## BEARING INSTALLATION

1. Press upper bearing cup in to the spindle housing.
2. Turn the spindle housing over and press in the lower bearing cup.
3. Place the lower bearing cone in the bearing cup. Next press the seal into the spindle housing. The inner lip of the seal must be DOWN, towards the bearing, so lubricant is sealed inside the housing.
4. Install the spindle in the housing. Lightly press the spindle to seat the cone onto the spindle.
5. Support the bottom of the spindle and press the upper bearing cone and bearing adjustment sleeve onto the spindle.
6. **NOTE: The spindle housing must turn freely when seating the bearing cone and sleeve.**
7. Press the two upper seals into the spindle housing. The inner lip of the seals must be UP, away from the bearing, so excess lubricant can escape.
8. Install the bearing adjustment nut (thin nut) so there is 1-1/6" clearance between the nut and the sleeve. Install the jam washer, placing the tab into the key-way. Install the bearing lock nut (thin nut) and hand tighten against jam washer and adjustment nut. See the following section for bearing adjustment.
9. Position the spindle housing horizontally with the drain hole oriented "up". Grease through the zerk with Tiger Spindle Lubricant (part number 06540000) until the grease purges from the drain hole.
10. Install the plug into the drain hole.

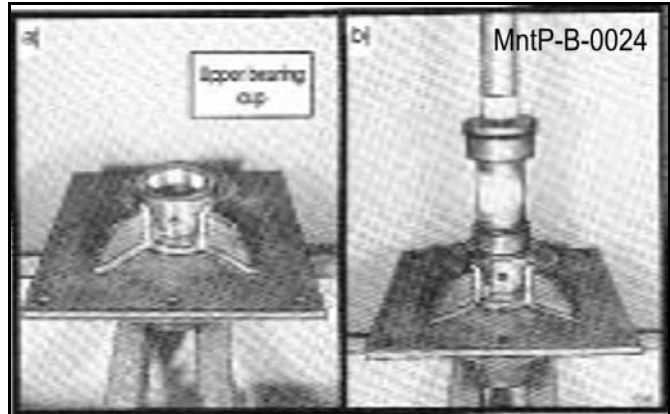

## BEARING ADJUSTMENT

1. Clamp the bottom end of the spindle housing securely in a vise so the spindle housing turns freely.
2. Position a magnetic base dial indicator on the outer diameter of the spindle housing. Locate the end of the dial indicator against the flat end of the spindle shaft. The dial indicator will now measure accurately bearing end play.
3. Tighten the bearing adjustment nut until there is .012 inch movement when the spindle housing is pried upward away from the vise jaws.
4. When there is .012 inch free play between the spindle and housing, install the bearing lock nut (thick nut). Hold the adjusting nut securely and tighten the lock nut to 300 ft. lbs. of torque.
5. After the lock nut is tightened, there must be .001 inch to .003 inch of free play when lightly prying up on the spindle housing.

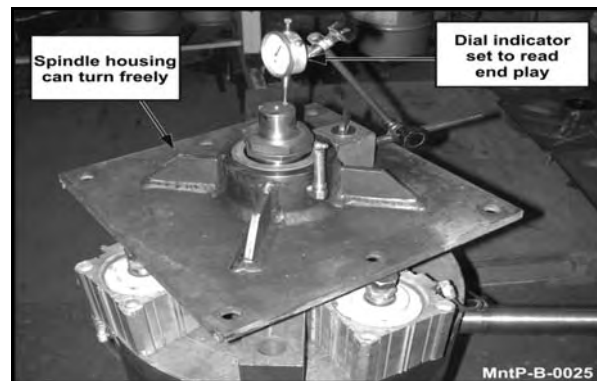

If the end play is correct, .001 inch to .003 inch, bend tabs up on jam washer to prevent the lock nut from loosening.

If the end play is NOT correct, loosen the lock nut and turn the adjustment nut as required and re-tighten the lock nut. Repeat first part of step 5.

# MAINTENANCE

## Boom Cylinder Removal and Replacement Instructions

1. Clear the area of all personnel before lowering the boom mower head.
2. From the tractor seat with your seat belt fastened around you, lower the boom mower head to the ground. Extend the boom to the furthest reach and lower the mower head flat on the ground. DO NOT attempt to replace the cylinders with the boom in the raised or transport position.
3. Shut off the tractor, engage the parking brake, place the tractor transmission in the park position, and remove the key before dismounting.
4. Allow the system to cool to room temperature before removing any hydraulic components
5. Wear safety glasses and impenetrable gloves when working with hydraulic hoses and fittings.
6. Release all oil pressure from the hydraulic circuit by manually stroking each valve section with the tractor engine off. Utilize the Manual Override function if the unit is equipped with an electric over hydraulic valve.
7. Utilize blocks, jack stands or a suitable over head hoist to support the weight of the boom section and remove pressure from the cylinder mounting pins.
8. Check to see that the cylinder to be replaced is not under pressure by moving the cylinder pins by hand. The pins should be loose and should slide freely in the pin bore easily. If the pins are tight and cannot be moved, the cylinder may be under pressure. Make sure the boom components are properly supported and that the pressure is relieved from the circuit.
9. Cylinder assemblies are heavy and can fall when the pins are removed. Support the hydraulic cylinder with a suitable hoist or jack.
10. Slowly loosen the hydraulic connections to the cylinder. Carefully unscrew hose fitting and allow any remaining pressure to bleed off. Use Extreme Care. Oil must be cool, and the technician should stand to the side to prevent exposure to any hydraulic oil. Always consult the Material Safety Data Sheet and wear any required Personal Protective Equipment. A catch pan may be required to retain any spilled oil.
11. Cap both ends of the fitting with suitably sized metal caps.
12. Remove the cylinder pins starting with the ROD end cylinder pin. Make sure the cylinder is properly supported, and remove the base end cylinder pin. The cylinder may be heavy, use proper lifting techniques to lift and handle the cylinder. If needed, get assistance from another person to safely lift the cylinder from the machine.
13. Measure the distance between the cylinder pin holes and extend the new cylinder the correct length prior to attempting an installation.
14. Install the new cylinder in place and install both cylinder pins and retaining hardware.
15. Remove the metal caps, and re-install the hydraulic hoses.
16. Check the hydraulic reservoir of the boom mower to ensure there is sufficient oil. Follow the manufacturer's recommendations for proper oil type and filtering techniques and requirements to add oil to the system.
17. Clear the area of all persons prior to starting the tractor.
18. Consult the Operator's Manual for instruction in regard to the proper operating procedure.
19. From the tractor seat, with the seat belt fastened, operate the boom to ensure proper operation of the boom function.
20. From the tractor seat, with the seat belt fastened, operate the boom controls to fully extend and retract the new cylinder several times to purge any trapped air from the system.
21. From the tractor seat, with the seat belt fastened, look for signs of and oil leak. If an oil leak is observed, shut the tractor down and follow the steps to remove pressure from the hydraulic circuit. Identify the source of the leak and resolve the issue.
22. Upon completion of the required repairs, return to Step # 16 to recheck the cylinder for proper operation.

# MAINTENANCE

## CUTTERSHAFT BEARING REPLACEMENT

1. Remove existing cuttershaft, bearings and string guards.
2. Make sure that the end knives on each end of the cuttershaft are oriented as shown.
3. Apply anti-seize on cuttershaft as shown on next page.
4. Install non-drive side bearing first.
5. Install the top of the string guard on the non-drive side first. Use Šoctite-271 or equivalent and torque (95 ft-lb or 104ft-lb if you use an extension).
6. Install the bearing and top string guard on the drive side.
7. Center the cuttershaft between the string guards. Use Šoctite-271 or equivalent and torque (95ft-lb or 104ft-lb if you use an extension) the top string guard on the drive side.
8. Install, use Šoctite-271 or equivalent, and torque (95ft-lb or 104ft-lb if you use an extension) the bottom string guard on both sides.
9. Make sure the cuttershaft is centered. On the non-drive side, tighten one set screw in the bearing onto the cuttershaft.
10. Remove the other set-screw and drill a 5/16" hole into the cuttershaft 3/16" deep through the hole in the bearing. BE CAREFUL NOT TO DAMAGE THE THREADS IN THE BEARING HOLE.
11. Replace the set screw in the bearing, use Šoctite-271 or equivalent, and tighten onto the cuttershaft through the new hole.
12. Remove the other set screw and repeat the drilling procedure (Step 10). Replace the set screw as stated in Step 11.
13. Repeat steps 9 through 12 on the drive side.
14. Grease both bearings properly.

**See illustration on next page**

# MAINTENANCE

MAINTENANCE

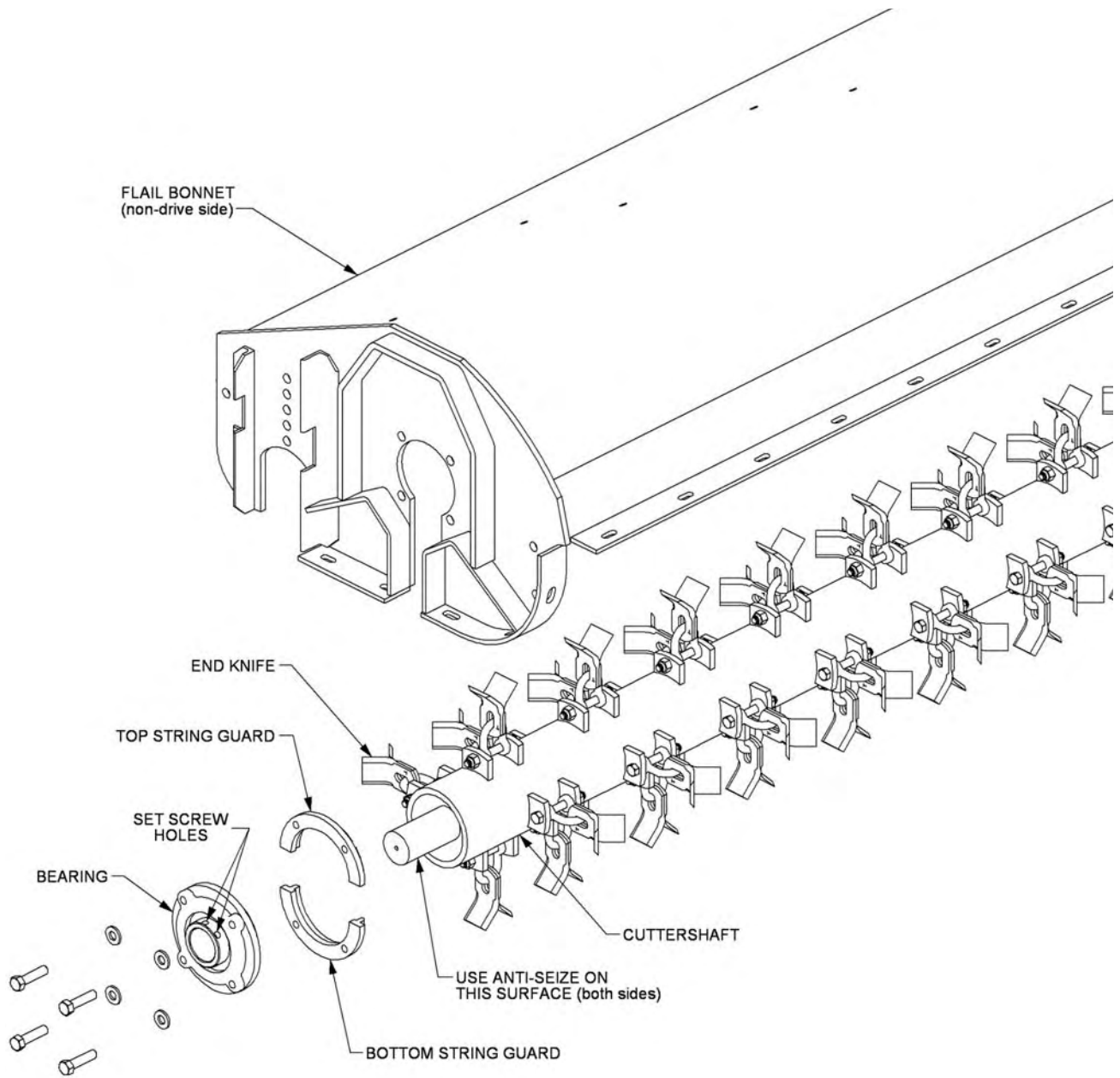



# MAINTENANCE

## DAILY MAINTENANCE SCHEDULE

The following services should be performed daily or every 8 hours of service, following the detailed maintenance instructions in the operators manual.

\_\_\_\_\_ Pump Drive Shaft: If required with drive shaft/coupler check for end play and lubricate at zerks.

\_\_\_\_\_ Crankshaft adapter: If equipped with rubber grommets check condition, replace if missing or damaged.

\_\_\_\_\_ Pivot points: Inject grease until it appears at ends.

\_\_\_\_\_ Hydraulic fittings: Check for leaks with paper or cardboard. Tighten fittings or replace hoses immediately.

\_\_\_\_\_ Knives: Inspect for missing or damaged knives, change (only complete sets) as needed.

\_\_\_\_\_ Belts: Check/Tighten/Replace belts as needed.

\_\_\_\_\_ Main Frame/Deck: Unless otherwise specified retorqued bolts according to torque specifications in this section.

\_\_\_\_\_ Hydraulic Fluid Level: Add, if required, per fluid recommendations.

\_\_\_\_\_ Rear Flail Drive, Bearing Flange and Shaft Couplers: Grease as instructed in the detailed maintenance section.

\_\_\_\_\_ Cutter Shaft and Ground Roller: Grease as instructed in the detailed Maintenance Section.

Service performed by: \_\_\_\_\_ Date: \_\_\_\_/\_\_\_\_/\_\_\_\_ Hour

Meter: \_\_\_\_\_

Maintenance Section

\*\*This page may be copied and used as part of the daily maintenance routine.

# MAINTENANCE

## MAINTENANCE

RSS

Maintenance Section 4-30

# 1118 REAR STOW SIDE MOWER

## PARTS SECTION

# PART NAME INDEX

RCTVUQTF GT&I 'I W&G	5
VTCEVQT'O QWP V'MK	6
VTCEVQT'O QWP V'MK/'E[ N&F GT'VCPI 'O QWP V	8
VTCEVQT'O QWP V'MK/'J [ F TCWN&U	:
UR I NG'EQNWO P 'DQO TGU	32
DCVGT[ 'TGNQECVQP	34
6"URQQN'ECDNG'EQP VTQN'O QWP V	36
ECDNG*'O CP WCN+'N&H'XCNXG/'6"URQQN	38
7"URQQN'ECDNG'EQP VTQN'O QWP V	3:
ECDNG*'O CP WCN+'N&H'XCNXG/'7"URQQN	42
LQ[ UV&M'CP F 'UY &EJ DQZ 'O QWP V	44
GNGEVTQP &'RTQRQTVQP CN'N&H'XCNXG'O QWP V	46
ECDNG*'O CP WCN+'N&H'XCNXG'DTGCMF QY P '/'28724354	48
ECDNG*'O CP WCN+'N&H'XCNXG'DTGCMF QY P '/'28724355	4:
RQN[ ECTDQPCVG'UCHGV[ 'Y &F QY	52
Y J GGN'URCEGT	54
Y J GGN'Y GK J V	55
P QVGU	56

## PARTS ORDERING GUIDE

The following instructions are offered to help eliminate needless delay and error in processing purchase orders for the equipment in this manual.

1. The Parts Section is prepared in logical sequence and grouping of parts that belong to the basic machine featured in this manual. Part Numbers and Descriptions are given to help locate the parts and quantities required.
2. The Purchase Order must indicate the **Name and Address** of the person or organization ordering the parts, **who should be charged**, and if possible, the **serial number of the machine** for which the parts are being ordered.
3. The purchase order must clearly list the **quantity of each part**, the complete and correct **part number**, and the basic **name of the part**.
4. The manufacturer reserves the right to substitute parts where applicable.
5. Some parts may be unlisted items which are special production items not normally stocked and are subject to special handling. Request a quotation for such parts before sending a purchase order.
6. The manufacturer reserves the right to change prices without prior notice.

NOTE: When ordering replacement decals, refer to the part numbers and descriptions listed in the safety section in the front of this manual.



For maximum safety and to guarantee optimum product reliability, always use genuine **Tiger** replacement parts. The use of inferior replacement parts may cause premature or catastrophic failure which could result in serious injury or death.

Direct any questions regarding parts to:

**Tiger Corporation**  
3301 N. Louise Ave.  
Sioux Falls, SD 57107  
1-800-843-6849  
1-605-336-7900

# TRACTOR MOUNT KIT

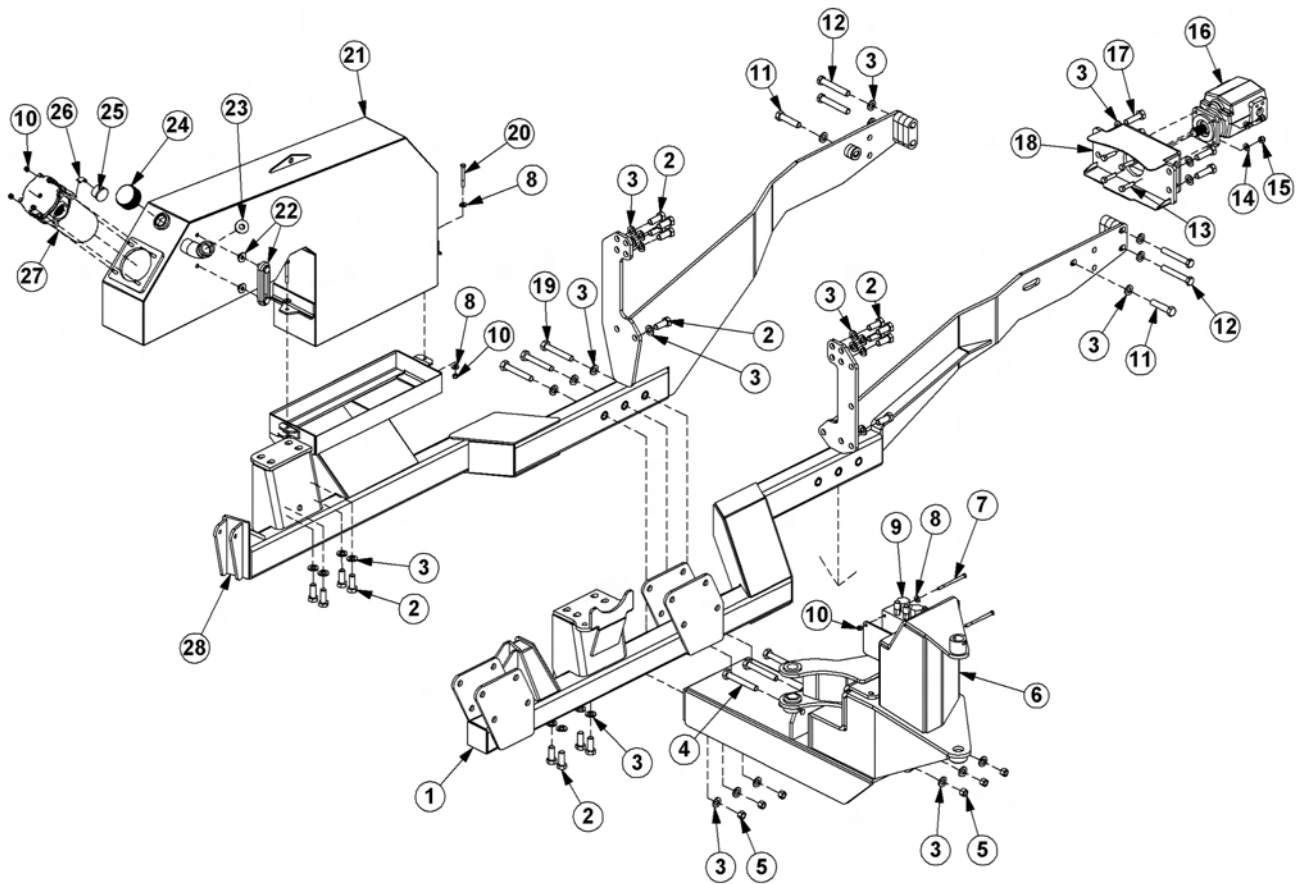

## TRACTOR MOUNT KIT

Continued...

ITEM	PART NO.	QTY.	DESCRIPTION
3	28522459	3	CZNG'DTCEG.TJ
4	53953	42	ECRUETGY .42O O 'Z'72O O .4ØR
5	55: : 2	64	HNCVY CUI GT.516\$.UCG
6	8V452;	5	ECRUETGY .516\$'Z'7/34\$.PE
7	43: 47	8	J GZ'P WW.516\$.PE
8	28522463	3	O CR 'HTCO G
9	43866	4	ECRUETGY .51 \$'Z'7\$.PE
:	44238	8	HNCVY CUI GT.51: \$
;	287322: 5	3	DTCMG'XCXNG
32	43849	:	P [ NQEMP WW.51: \$.PE
33	5292:	4	ECRUETGY .42O O 'Z'; 2O O .4ØR
34	28752764	6	ECRUETGY .42O O 'Z'352O O .4ØR
35	43955	6	ECRUETGY .34\$'Z'4\$.PE
36	28755226	6	HNCVY CUI GT.34\$.UCG
37	43949	6	P [ NQEMP WW.34\$.PE
38	45374	3	RWOR
39	47563	6	ECRUETGY .42O O 'Z'92O O .4ØR
3:	285: 2283	3	O QWP V.RWOR
3;	43: 64	5	ECRUETGY .516\$'Z'7\$.PE
42	4385;	4	ECRUETGY .51 \$'Z'5/316\$.PE
43	289222; 3	3	J [ FTCWN'E'VCP M'CUUGO DN]
44	28727289	3	UK J V'I CW G
45	28727349	3	RNWI .UCG%42
46	28727299	3	DTGCVJ GT'ECR
47	8V286;	3	HKNVGT'I CW G
48	VH6: ::	3	UVTGGV'GNDQY .31: \$P RV
49	28727266	3	TGVWTP 'HKNVGT
4:	28522457	3	CZNG'DTCEG.NJ

# TRACTOR MOUNT KIT - CYLINDER TANG MOUNT

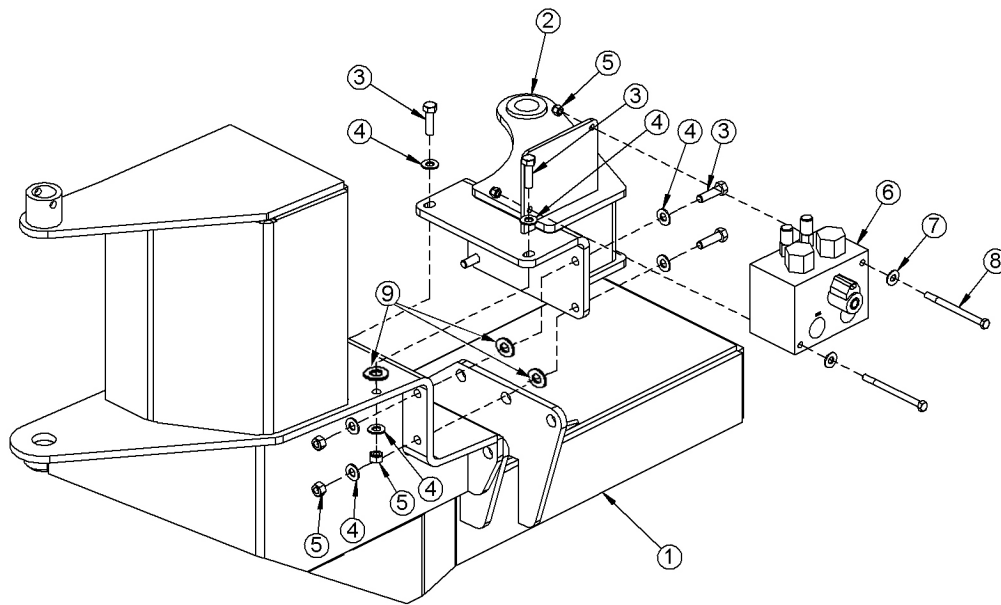



## TRACTOR MOUNT KIT - CYLINDER TANG MOUNT

Continued...

ITEM	PART NO.	QTY.	DESCRIPTION
1	-----	-	MAIN FRAME *REFER TO TRACTOR MOUNT KIT
2	06300242	1	CYLINDER TANG
3	6T1027	6	CAPSCREW,1/2" X 1-3/4",NC
4	06533004	12	FLATWASHER,1/2",SAE
5	21727	6	NYLOCK NUT,1/2",NC
6	-----	-	BRAKE VALVE *REFER TO TRACTOR MOUNT KIT
7	-----	-	FLATWASHER *REFER TO TRACTOR MOUNT KIT
8	-----	-	CAPSCREW *REFER TO TRACTOR MOUNT KIT
9	27938	-	BUSHING, MACHINED (AS NEEDED)

# TRACTOR MOUNT KIT - HYDRAULICS

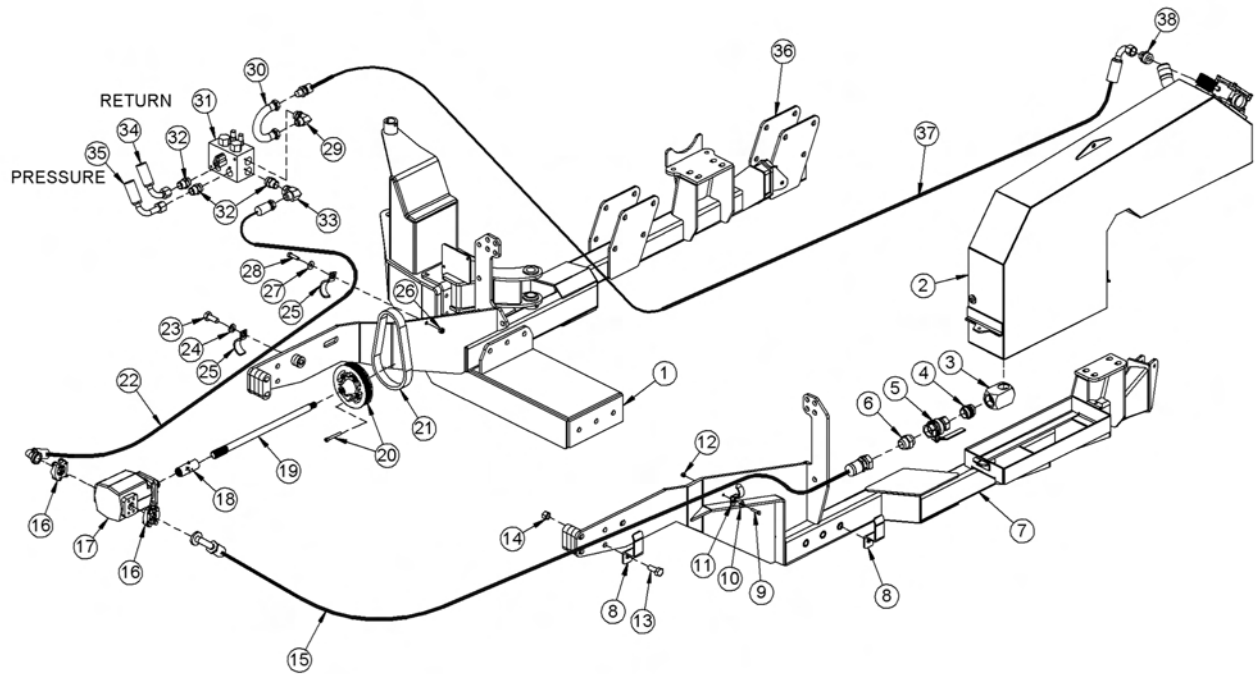

## TRACTOR MOUNT KIT - HYDRAULICS

Continued...

ITEM	PART NO.	QTY.	DESCRIPTION
1	06300241	1	MAIN FRAME
2	06700091	1	TANK, HYDRAULIC, WHEEL WELL
3	06503084	1	ELBOW, 1-1/2" FOR X 1-1/2" FOR
4	06503083	1	ADAPTER, 1-1/2" MOR X 1-1/2" MOR
5	34309	1	BALL VALVE, 1-1/2" FOR
6	34710	1	ADAPTER, 1-1/2" MOR X 1-1/2" MJ
7	06300235	1	AXLE BRACE, LH
8	32382	2	BRACKET, HOSE
9	21632	1	CAPSCREW, 3/8" X 1-1/2", NC
10	22016	1	FLATWASHER, 3/8"
11	06411136	1	BRACKET, HOSE
12	21627	1	NYLOCK NUT, 3/8", NC
13	21832	1	CAPSCREW, 3/4" X 2", NC
14	21827	1	NYLOCK NUT, 3/4", NC
15	06500680	1	HOSE, 1-1/2" X 107"
16	TF4852	2	KIT, FLANGE, #20
17	23152	1	PUMP
18	6T0375B	1	COUPLING
19	06420166	1	DRIVE SHAFT
20	DLV32899	1	JOHN DEERE PULLEY KIT
21	T208891	1	JOHN DEERE BELT
22	06500274	1	HOSE, 1" X 74"
23	30708	1	CAPSCREW, 20MM X 90MM, 2.5P
24	33880	1	FLATWASHER, 3/4"
25	TB3012	2	CLAMP, HOSE
26	21727	1	NYLOCK NUT, 1/2", NC
27	22018	1	FLATWASHER, 1/2"
28	21732	1	CAPSCREW, 1/2" X 1-3/4"
29	34117	1	ELBOW, 1" MOR X 1" MJ
30	06506012	1	PREFORMED TUBE
31	06510083	1	BRAKE VALVE
32	33555	3	ADAPTER, 1" MOR X 1" MJ
33	33259	1	ELBOW, 1" MOR X 1" FJX90
34	06500605	1	HOSE, 1" X 65" (RETURN)
35	06500604	1	HOSE, 1" X 67" (PRESSURE)
36	06300237	1	AXLE BRACE, RH
37	06500747	1	HOSE, 1" X 115"
38	34064	1	ADAPTER, 1-1/4" MOR X 1" MJ

# SINGLE COLUMN BOOMREST

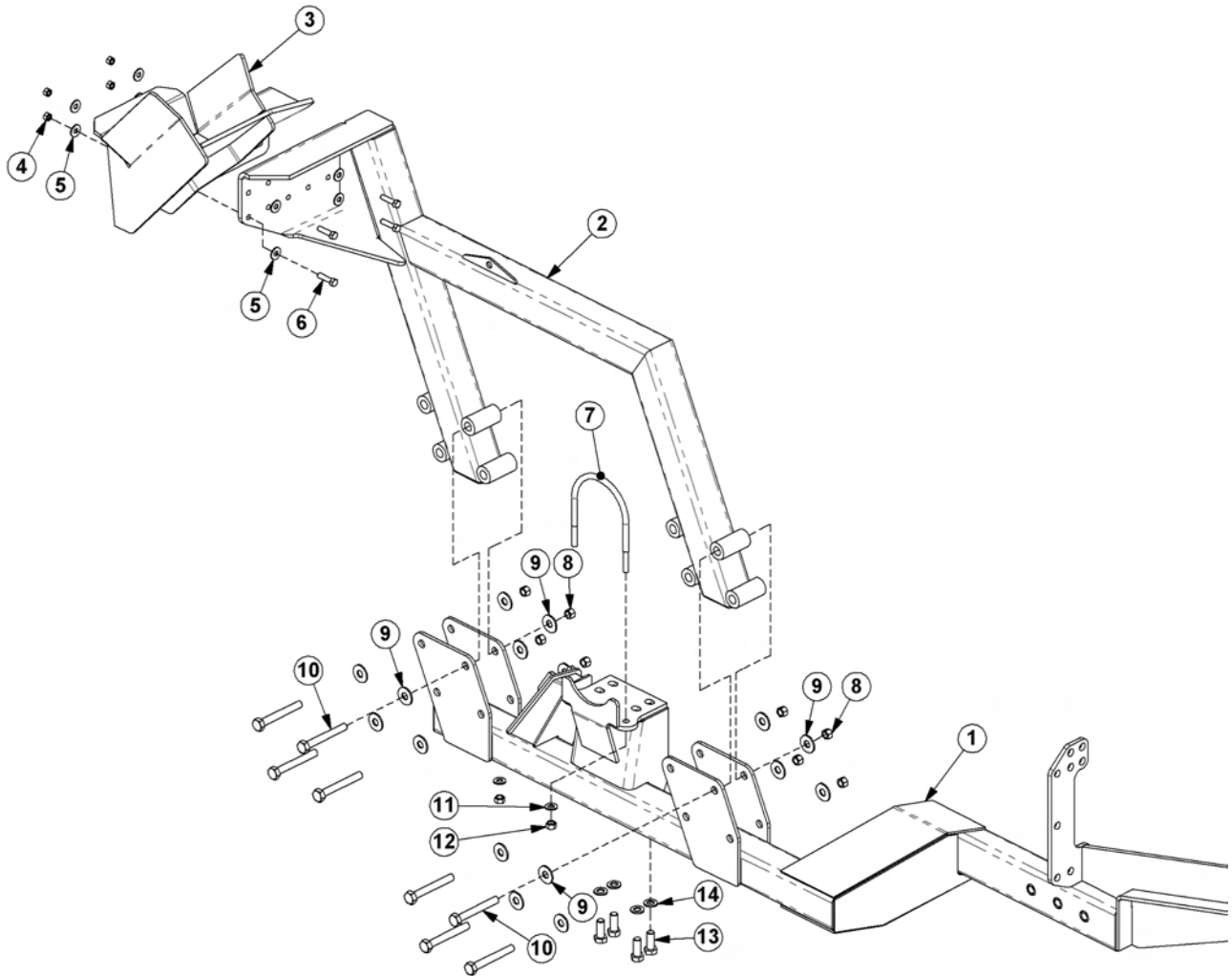

## SINGLE COLUMN BOOMREST

Continued...

ITEM	PART NO.	QTY.	DESCRIPTION
1	06300237	1	AXLE BRACE,SINGLE COLUMN
2	06310074	1	BOOMREST,SINGLE COLUMN
3	06310116	1	SADDLE
4	21725	4	HEX NUT,1/2",NC
5	06533004	8	FLATWASHER,1/2",SAE
6	21732	4	CAPSCREW,1/2" X 1-3/4",NC
7	06420127	1	U-BOLT,5/8" X 7-1/8"
8	21825	8	HEX NUT,3/4",NC
9	22021	16	FLATWASHER,3/4"
10	21843	8	CAPSCREW,3/4" X 6",NC
11	33764	2	FLATWASHER,5/8",SAE
12	6T2408	2	HEX NUT,5/8",NF
13	31731	4	CAPSCREW,20MM X 50MM,2.5P
14	33880	4	FLATWASHER,3/4",SAE

# BATTERY RELOCATION

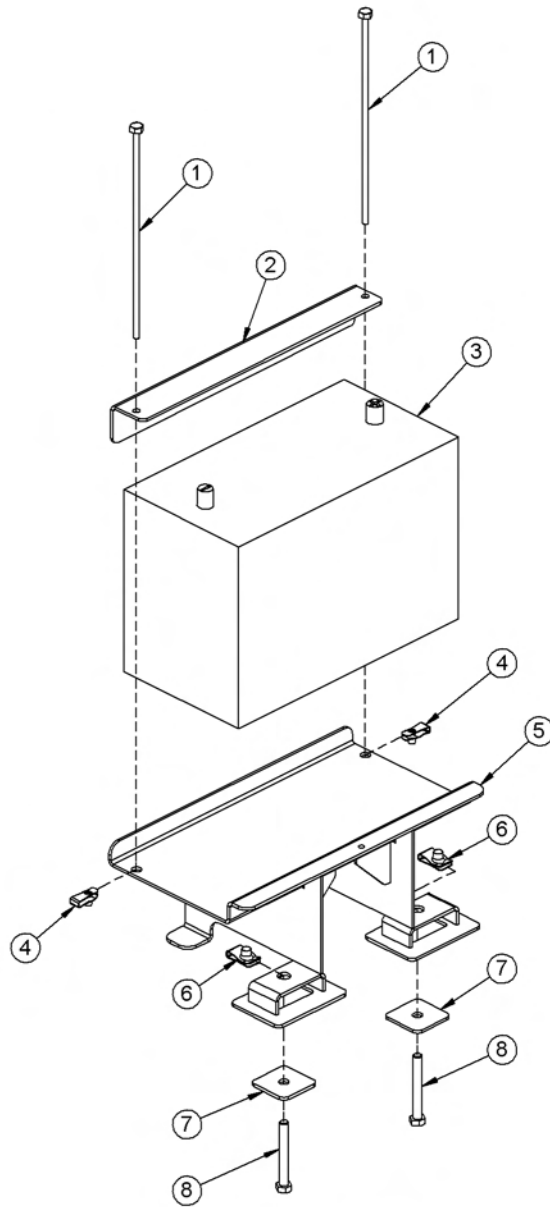

## BATTERY RELOCATION

Continued...

ITEM	PART NO.	QTY.	DESCRIPTION
1	28752456	2	CAPSCREW,1/4" X 10",NC
2	06411429	1	ANGLE
3	-----	-	BATTERY *EXISTING PART
4	35176	2	NUT CLIP,1/4",NC
5	06370231	1	RELOCATION BRACKET
6	06537029	2	NUT CLIP,3/8",NC
7	064239: 6	2	SQUARE PLATE
8	21638	2	CAPSCREW,3/8" X 3",NC

# 4 SPOOL CABLE CONTROL MOUNT

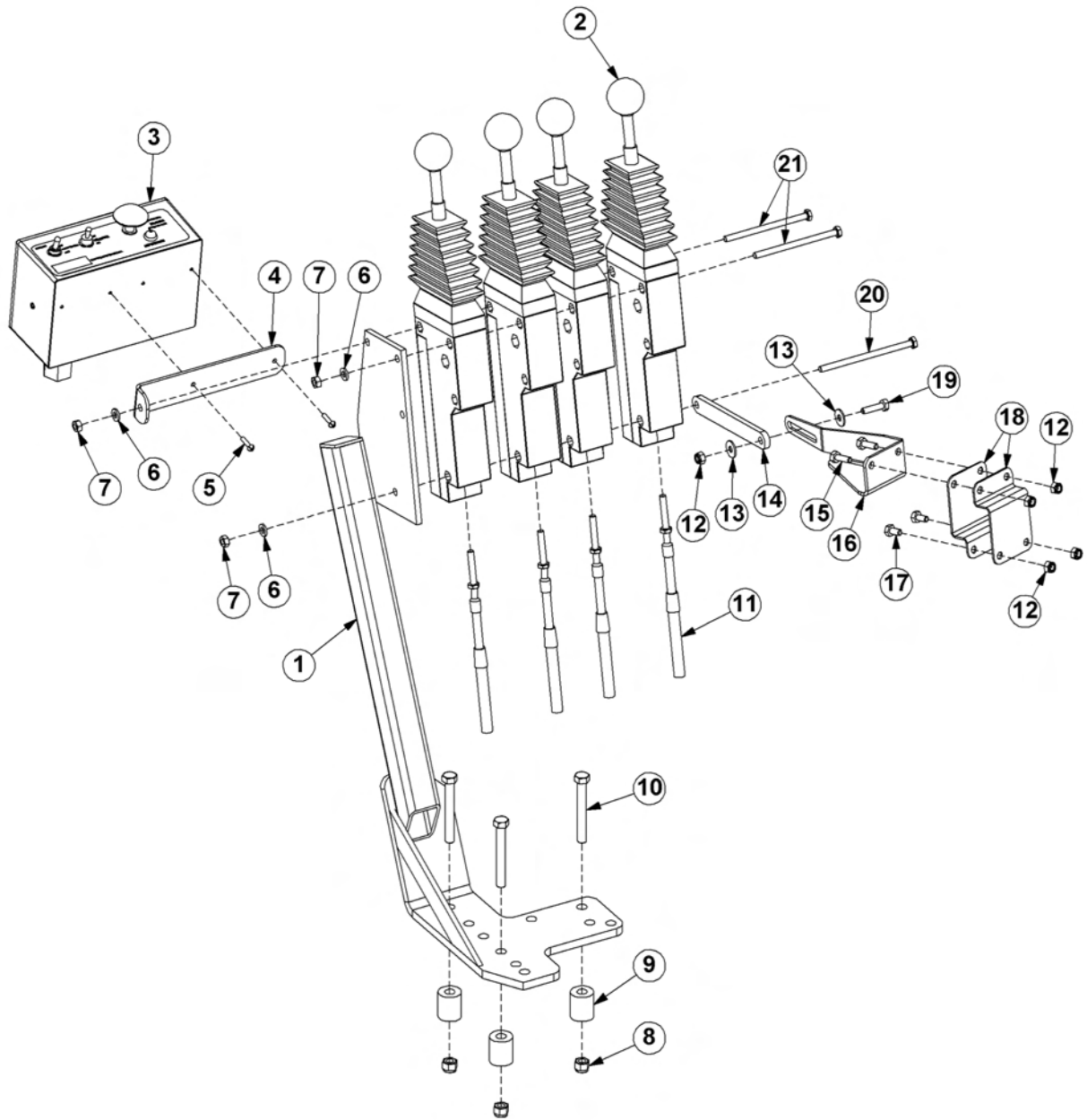



## 4 SPOOL CABLE CONTROL MOUNT

Continued...

ITEM	PART NO.	QTY.	DESCRIPTION
1	23865B	1	BRKT,CTRL,CBL
2	6T1251	4	CBL CTRL BOX,180 DEG
3	06510100	1	SWITCH BOX,BOOM
4	34496	1	BRKT,SWITCH BOX
5	6T3951	2	SCREW,MACHINE,8-32 X 1/2"
6	21986	3	LOCKWASHER,1/4"
7	21525	3	HEX NUT,1/4",NC
8	21627	3	NYLOCK NUT,3/8",NC
9	27082B	3	SPACER
10	21636	3	CAPSCREW,3/8" X 2-1/2",NC
11	06505100	4	CBL,CNTRL,108"
12	21527	5	NYLOCK NUT,1/4",NC
13	22014	2	FLATWASHER,1/4"
14	06402045	1	SUPPORT,STAND
15	21529	2	CAPSCREW,1/4" X 3/4",NC
16	06411087	1	BRKT,STABILIZER
17	21528	2	CAPSCREW,1/4" X 1/2",NC
18	06411086	2	BRKT,MNT
19	21530	1	CAPSCREW,1/4" X 1",NC
20	21547	1	CAPSCREW,1/4" X 8",NC
21	21546	2	CAPSCREW,1/4" X 7",NC

# CABLE (MANUAL) LIFT VALVE - 4 SPOOL

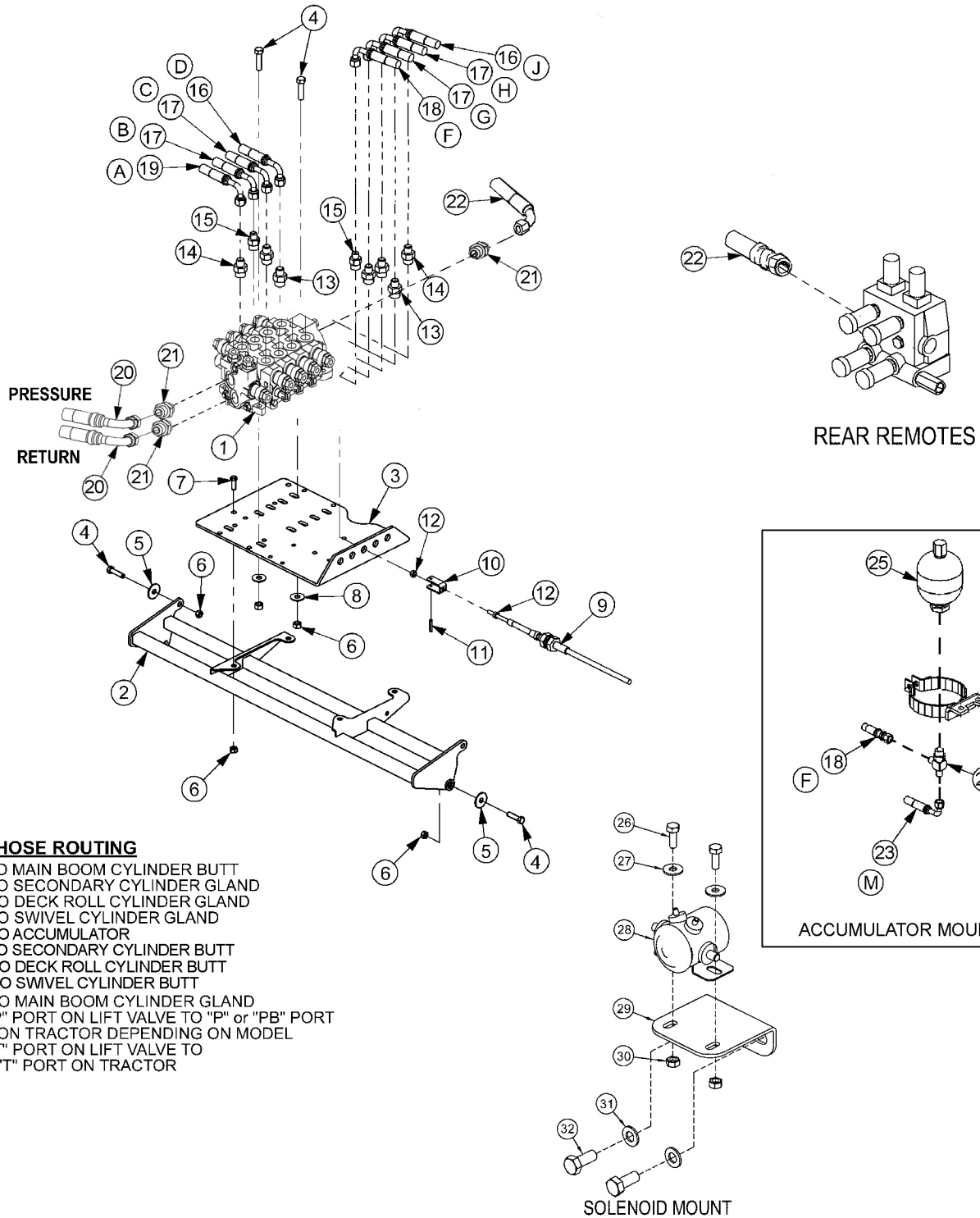

## CABLE (MANUAL) LIFT VALVE - 4 SPOOL

Continued...

ITEM	PART NO.	QTY.	DESCRIPTION
1	06502117	1	VALVE,5SP,OC
2	06340033	1	VALVE MNT
3	34622	1	PLATE,VALVE,REAR MNT
4	21632	8	CAPSCREW,3/8" X 1-1/2",NC
5	6T2615	4	WASHER,FENDER,3/8"
6	21627	12	NYLOCK NUT,3/8",NC
7	21630	4	CAPSCREW,3/8" X 1",NC
8	22016	4	FLATWASHER,3/8"
9	06505100	5	CBL,CNTRL,108"
10	6T4411	5	CLEVIS,CBL CTRL,3/16"
11	6T3017	5	ROLLPIN,3/16" X 1"
12	21500	10	HEX NUT,1/4",NF
13	34396	2	ADAPTER,.06"RSTRCTR,1/2"MOR X 3/8"MJ
14	33271	4	ADAPTER,1/2"MOR X 3/8"MJ
15	06502036	2	VLV,CHECK,W/.06"MOR X 1/2"MOR X 3/8"
16	33364	2	HOSE,1/4" X 120"
17	34358	4	HOSE,1/4" X 196"
18	33562	1	HOSE,1/4" X 130"
19	06500164	1	HOSE,1/4" X 216"
20	06500782	2	HOSE, 1-1/2" X 70"
21	06503023	3	ADAPTER, 3/4" ORB X 3/4" MJ
22	06500783	1	HOSE, 1-1/2" X 30"
23	33745	1	HOSE,1/4" X 100"
24	06503029	-	TEE,RUN,1/2"MOR X 3/8"MJ X 3/8"MJ
25	24300	1	ACCUMULATOR
26	21529	2	CAPSCREW,1/4" X 3/4",NC
27	22014	2	FLATWASHER,1/4"
28	6T3927	1	CONTINUOUS DUTY SOLENOID
29	06411085	1	BRKT,MNT,SOLENOID
30	21527	2	NYLOCK NUT,1/4",NC
31	32724	2	FLATWASHER,10MM
32	27513	2	CAPSCREW,10MM X 35MM,1.5P
33	33383	1	ELBOW,5/8"MOR X 1/2"MJ X 90°
34	33293	1	ELBOW,LONG,1/2"MOR X 1/2"MJ 90°
35	32678	1	ADAPTER,5/8"MOR X 1/2"FOR

# 5 SPOOL CABLE CONTROL MOUNT

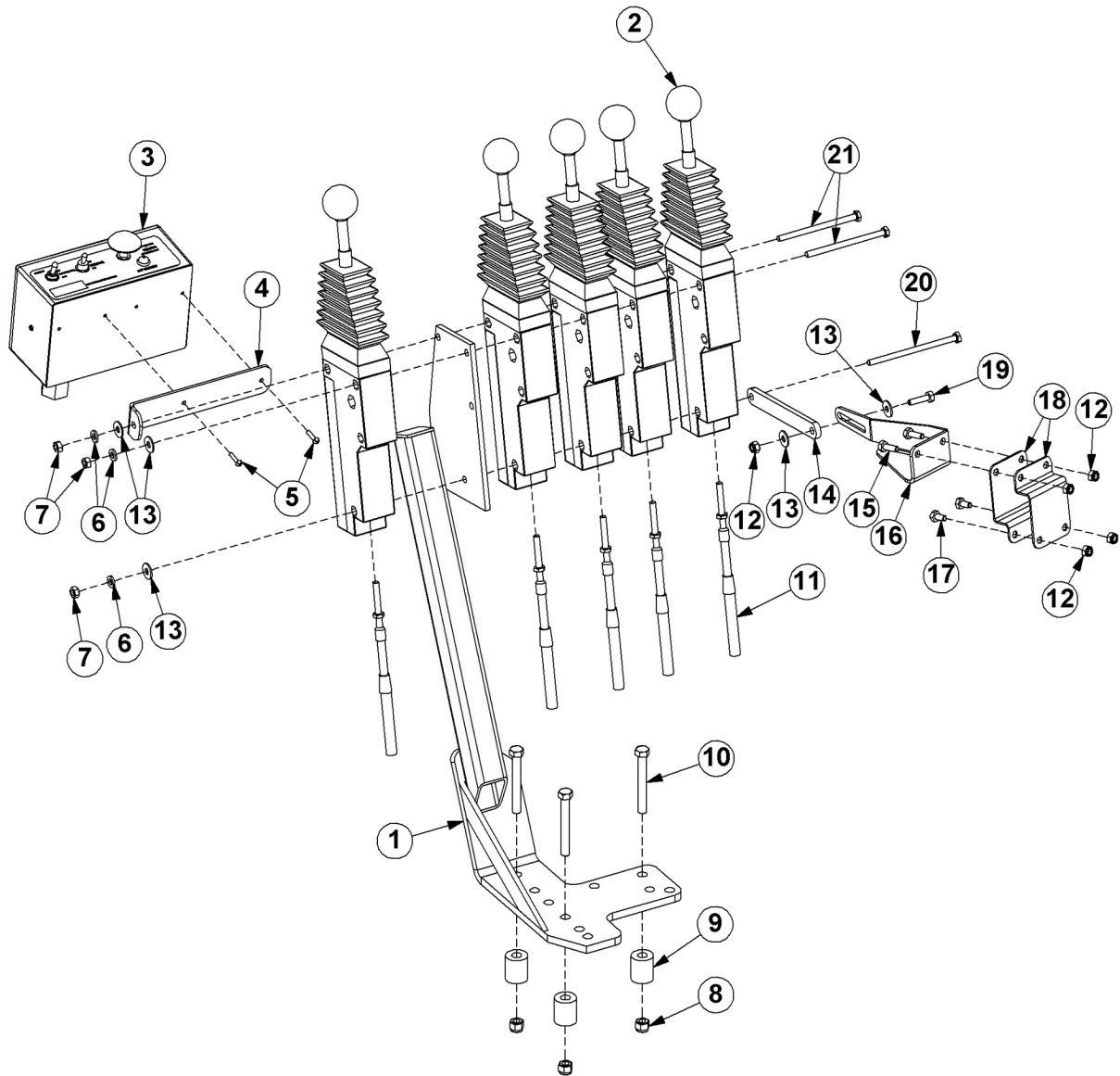

## 5 SPOOL CABLE CONTROL MOUNT

Continued...

ITEM	PART NO.	QTY.	DESCRIPTION
1	23865B	1	BRKT,CTRL,CBL
2	6T1251	5	CBL CTRL BOX,180 DEG
3	06510100	1	SWITCH BOX,BOOM
4	34496	1	BRKT,SWITCH BOX
5	6T3951	2	SCREW,MACHINE,8-32 X 1/2"
6	21986	3	LOCKWASHER,1/4"
7	21525	3	HEX NUT,1/4",NC
8	21627	3	NYLOCK NUT,3/8",NC
9	27082B	3	SPACER
10	21636	3	CAPSCREW,3/8" X 2-1/2",NC
11	06505100	5	CBL,CNTRL,108"
12	21527	5	NYLOCK NUT,1/4",NC
13	22014	5	FLATWASHER,1/4"
14	06402045	1	SUPPORT,STAND
15	21529	2	CAPSCREW,1/4" X 3/4",NC
16	06411087	1	BRKT,STABILIZER
17	21528	2	CAPSCREW,1/4" X 1/2",NC
18	06411086	2	BRKT,MNT
19	21530	1	CAPSCREW,1/4" X 1",NC
20	34332	1	CAPSCREW,1/4" X 9-1/4",NC
21	21548	2	CAPSCREW,1/4" X 9",NC

# CABLE (MANUAL) LIFT VALVE - 5 SPOOL

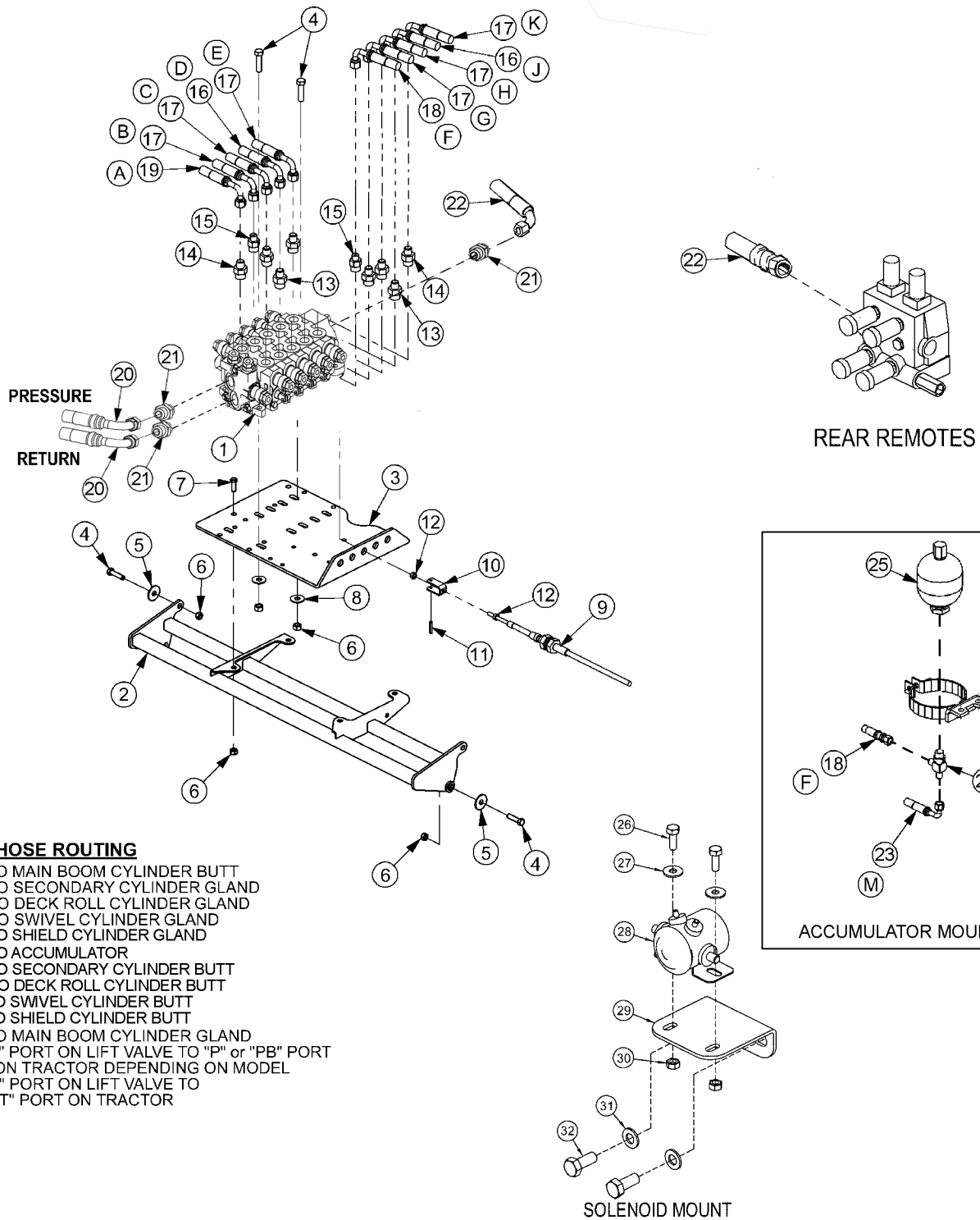

## CABLE (MANUAL) LIFT VALVE - 5 SPOOL

Continued...

ITEM	PART NO.	QTY.	DESCRIPTION
1	06502116	1	VALVE,5SP,OC
2	06340033	1	VALVE MNT
3	34622	1	PLATE,VALVE,REAR MNT
4	21632	8	CAPSCREW,3/8" X 1-1/2",NC
5	6T2615	4	WASHER,FENDER,3/8"
6	21627	12	NYLOCK NUT,3/8",NC
7	21630	4	CAPSCREW,3/8" X 1",NC
8	22016	4	FLATWASHER,3/8"
9	06505100	5	CBL,CNTRL,108"
10	6T4411	5	CLEVIS,CBL CTRL,3/16"
11	6T3017	5	ROLLPIN,3/16" X 1"
12	21500	10	HEX NUT,1/4",NF
13	34396	2	ADAPTER,.06"RSTRCTR,1/2"MOR X 3/8"MJ
14	33271	6	ADAPTER,1/2"MOR X 3/8"MJ
15	06502036	2	VLV,CHECK,W/.06"MOR X 1/2"MOR X 3/8"
16	33364	2	HOSE,1/4" X 120"
17	34358	6	HOSE,1/4" X 196"
18	33562	1	HOSE,1/4" X 130"
19	06500164	1	HOSE,1/4" X 216"
20	06500782	2	HOSE, 1-1/2" X 70"
21	06503023	3	ADAPTER, 3/4" ORB X 3/4" MJ
22	06500783	1	HOSE, 1-1/2" X 30"
23	33745	1	HOSE,1/4" X 100"
24	06503029	-	TEE,RUN,1/2"MOR X 3/8"MJ X 3/8"MJ
25	24300	1	ACCUMULATOR
26	21529	2	CAPSCREW,1/4" X 3/4",NC
27	22014	2	FLATWASHER,1/4"
28	6T3927	1	CONTINUOUS DUTY SOLENOID
29	06411085	1	BRKT,MNT,SOLENOID
30	21527	2	NYLOCK NUT,1/4",NC
31	32724	2	FLATWASHER,10MM
32	27513	2	CAPSCREW,10MM X 35MM,1.5P
33	33383	1	ELBOW,5/8"MOR X 1/2"MJ X 90°
34	33293	1	ELBOW,LONG,1/2"MOR X 1/2"MJ 90°
35	32678	1	ADAPTER,5/8"MOR X 1/2"FOR

# JOYSTICK AND SWITCHBOX MOUNT

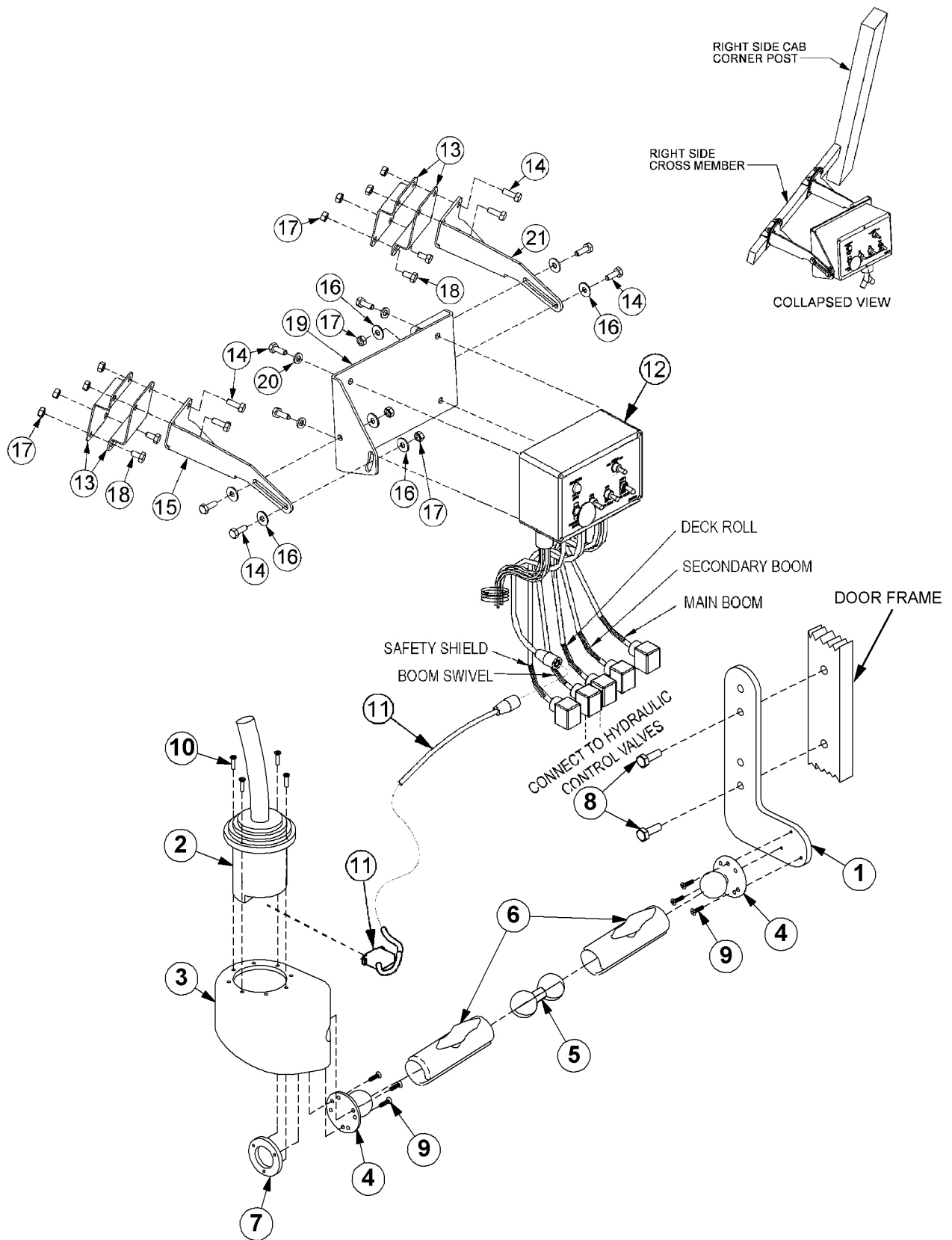



## JOYSTICK AND SWITCHBOX MOUNT

Continued...

ITEM	PART NO.	QTY.	DESCRIPTION
1	06340031	1	MT,BRKT,JYSTK
2	33691	1	JOYSTICK
3	06770022	1	CAN,JOYSTICK
4	06520019	2	MOUNT,RAM BALL,1-1/2",FLANGE
5	06520290	1	MOUNT,RAM,BALL,DBL,1-1/2"
6	06520020	2	MOUNT,RAM,ARM,1-1/2" X 4-5/8",STD
7	06400882	1	RING,BOLT,MNT,JYSTK
8	23113	2	CAPSCREW,10MM X 30MM,1.5P
9	32990	6	SCREW,MACHINE,10-32 X 1/2",RD HD
10	32829	4	SCREW,MACHINE,10-32 X 3/4",FLT HD
11	33693	1	CBL,EXT,4FT
12	06510196	1	SWITCH BOX,DF,BOOM
13	06411086	4	BRKT,MNT
14	21529	8	CAPSCREW,1/4" X 3/4",NC
15	06411087	1	BRKT,STABILIZING,LT
16	22014	8	FLATWASHER,1/4"
17	21527	12	NYLOCK NUT,1/4",NC
18	21528	4	CAPSCREW,1/4" X 1/2",NC
19	06411116	1	BRKT,MNT,SWITCH BOX
20	21986	4	LOCKWASHER,1/4"
21	06411378	1	BRKT,STABILIZING,RT

# ELECTRONIC PROPORTIONAL LIFT VALVE MOUNT

## HOSE ROUTING

- A - TO MAIN BOOM CYLINDER GLAND
- B - TO MAIN BOOM CYLINDER BUTT
- C - PRESSURE FROM PRIORITY VALVE TO LIFT VALVE
- D - LOAD SENSE LINE FROM PRIORITY VALVE TO LIFT VALVE
- E - LINE FROM LIFT VALVE TO ACCUMULATOR
- F - TO SECONDARY BOOM CYLINDER BUTT
- G - TO SECONDARY BOOM CYLINDER GLAND
- H - TO DECK ROLL CYLINDER BUTT
- J - TO TRAVEL LOCK VALVE ON DECK ROLL CYLINDER GLAND
- K - TO BOOM SWIVEL CYLINDER BUTT
- L - TO BOOM SWIVEL CYLINDER GLAND
- M - TO SAFETY SHIELD CYLINDER GLAND
- N - TO SAFETY SHIELD CYLINDER BUTT
- P - FROM TRACTOR PRESSURE TO PRIORITY VALVE
- Q - FROM LIFT VALVE RETURN TO PRIORITY VALVE
- R - FROM PRIORITY VALVE TO RETURN PORT OF TRACTOR

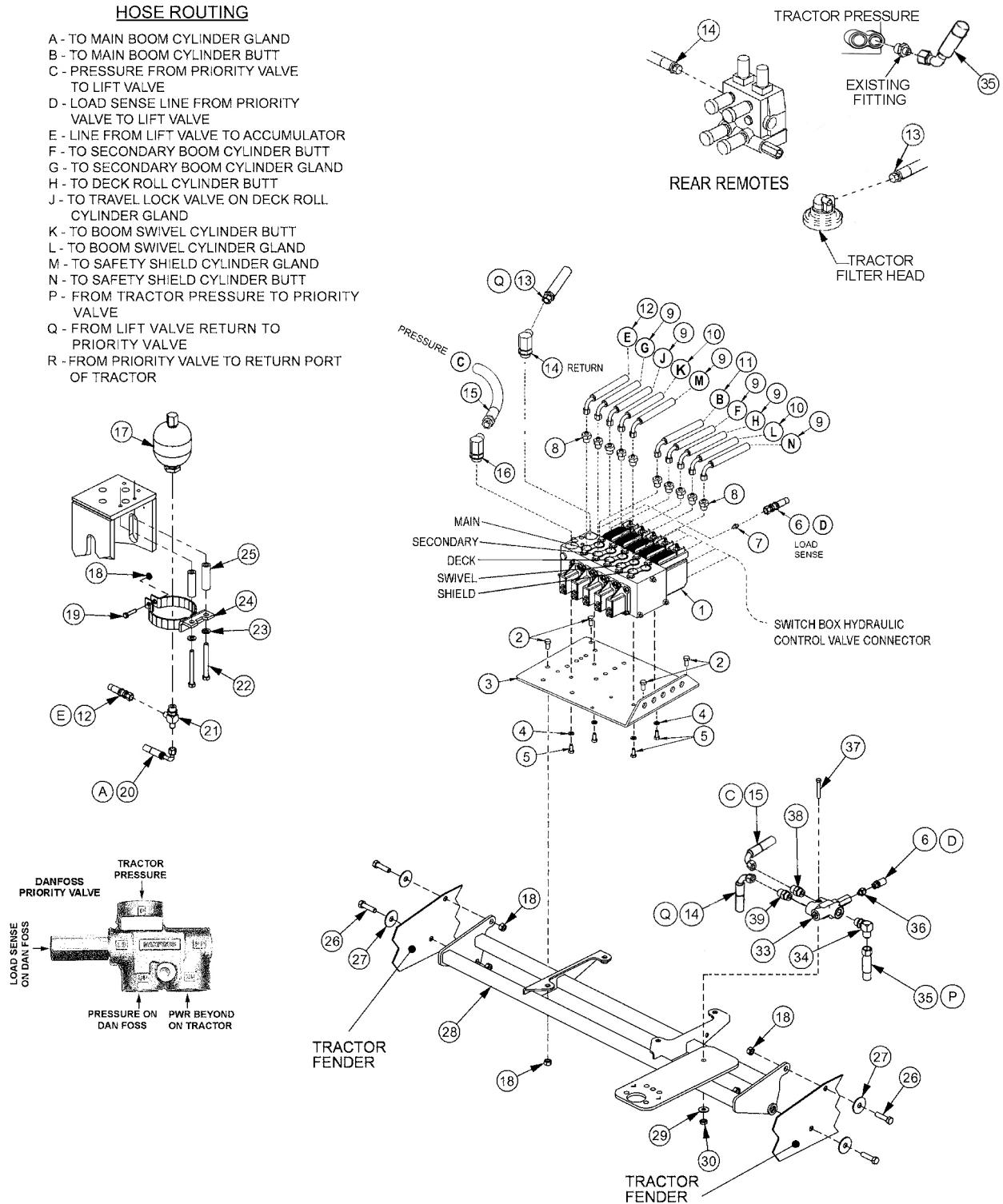

ITEM	PART NO.	QTY.	DESCRIPTION
1	06502097	1	ELECTRONIC VALVE
2	21630	4	CAPSCREW, 3/8" X 1", NC

## ELECTRONIC PROPORTIONAL LIFT VALVE MOUNT

Continued...

ITEM	PART NO.	QTY.	DESCRIPTION
3	34622	1	PLATE,VALVE,REAR MNT
4	21987	4	LOCKWASHER,5/16"
5	21579	4	CAPSCREW,5/16" X 3/4",NC
6	06500789	1	HOSE,3/8" X 60"
7	33392	1	ADAPTER,5/16"MB X 3/8"MJ
8	32807	10	ADAPTER,5/8"MB X 3/8"MJ
9	34358	6	HOSE,1/4" X 196"
10	33364	2	HOSE,1/4" X 120"
11	06500164	1	HOSE,1/4" X 216"
12	33562	1	HOSE,1/4" X 130"
13	06500788	1	HOSE,3/4" X 52"
14	06500786	1	HOSE, 3/4" X 52"
15	06500787	1	HOSE, 3/4" X 40"
16	33280	1	ELBOW,3/4"MJ X 3/4" MB ADJUSTABLE
17	24300	2	ACCUMULATOR
18	21627	9	NYLOCK NUT,3/8",NC
19	-----	-	CAPSCREW *REFER TO BOOM MNT KIT PAGE
20	33745	1	HOSE,1/4" X 100"
21	06503029	1	TEE,RUN,1/2"MB X 3/8"MJ X 3/8"MJ
22	-----	-	CAPSCREW *REFER TO BOOM MNT KIT PAGE
23	-----	-	LOCKWASHER *REFER TO BOOM MNT KIT PAGE
24	-----	-	BRKT *REFER TO BOOM MNT KIT PAGE
25	-----	-	SPACER *REFER TO BOOM MNT KIT PAGE
26	21632	4	CAPSCREW,3/8" X 1-1/2",NC
27	6T2615	4	WASHER,FENDER,3/8"
28	06340033	1	VALVE MOUNT
29	22015	1	FLATWASHER,5/16"
30	21577	1	NYLOCK NUT,5/16",NC
31	06503035	1	TEE,5/8"MJ X 5/8"FJX X 5/8"MJ
32	06500479	1	HOSE,5/8" X 30"
33	06502102	1	PRIORITY VALVE
34	06503033	1	ELBOW,5/8"MB X 5/8"MJ
35	06500785	1	HOSE,5/8" X 46"
36	06503057	1	ADAPTER,1/4"MB X 3/8"MJ
37	21585	1	CAPSCREW,5/16" X 2-1/2"
38	06503006	1	ADAPTER, 1/2" MORB X 3/4" MJ
39	06503188	1	ADAPTER,5/8"MB X 3/4" MJ

CABLE (MANUAL) LIFT VALVE BREAKDOWN - 06502132

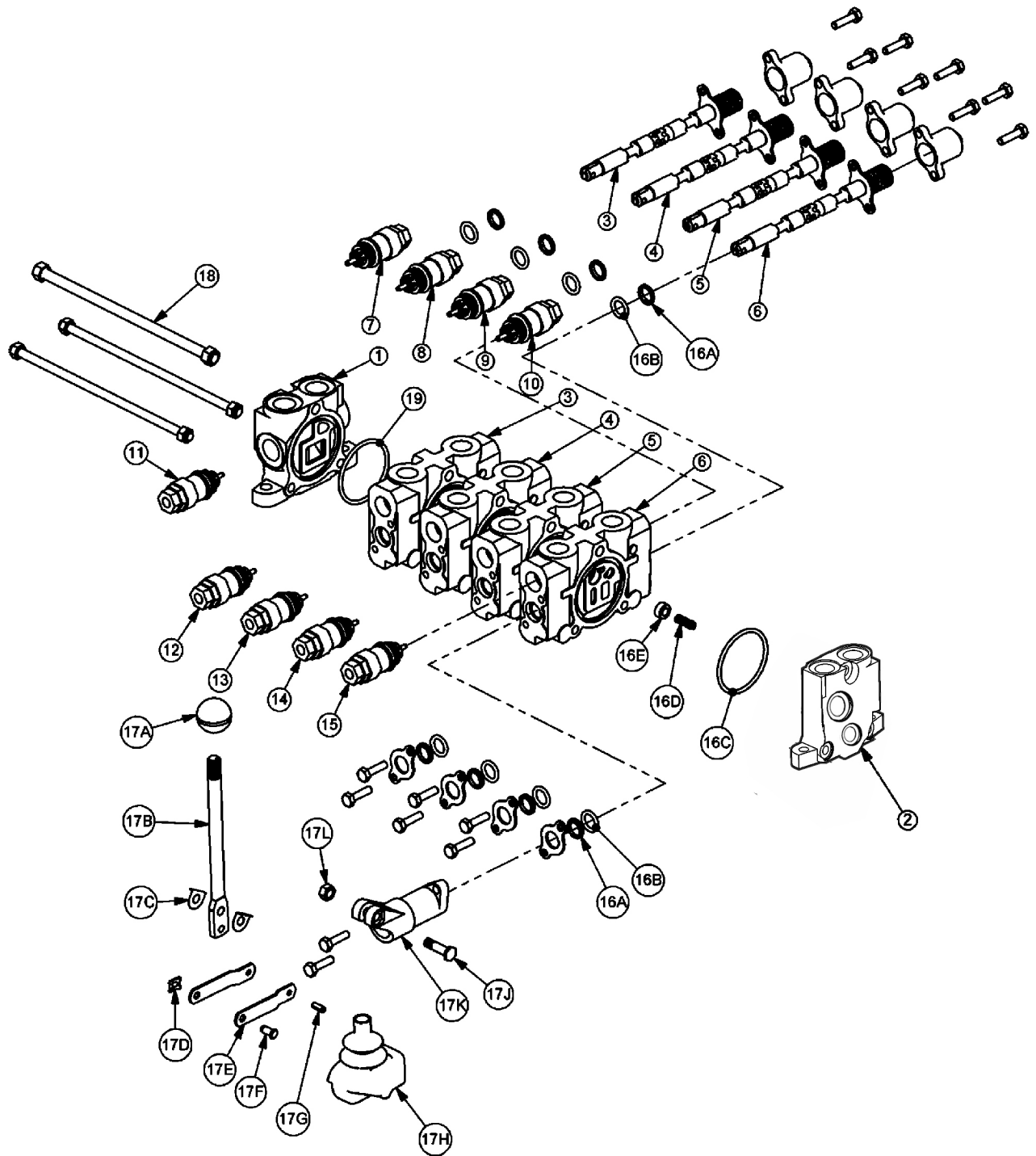

## CABLE (MANUAL) LIFT VALVE BREAKDOWN - 06502132

Continued...

ITEM	PART NO.	QTY.	DESCRIPTION
1	06502149	1	INLET END COVER
2	06502150	1	END COVER, OPEN CENTER
3	TF3009	1	VALVE SECTION (DOUBLE ACTING, DETENT - FLOAT)
4	TB1017N	1	VALVE SECTION (DOUBLE ACTING, CENTER SPRING)
5	TF3009	1	VALVE SECTION (DOUBLE ACTING, DETENT - FLOAT)
6	TB1017Q	1	VALVE SECTION (DOUBLE ACTING, SPRING METERED)
7	06503067	1	#10 O-RING PLUG
8	TB1017K	1	RELIEF VALVE, 2150 PSI
9	TB1017J	1	RELIEF VALVE, 1800 PSI
10	TB1017H	1	RELIEF VALVE, 1750 PSI
11	6T4209	1	#10 O-RING PLUG
12	06502003	1	RELIEF VALVE, 2500 PSI
13	TB1017K	1	RELIEF VALVE, 2150 PSI
14	TB1017F	1	RELIEF VALVE, 1500 PSI
15	TB1017H	1	RELIEF VALVE, 1750 PSI
16	TB1017A	4	VALVE SEAL KIT (FOR ONE SECTION)
16A	-----	2	WIPER
16B	-----	2	O-RING SMALL
16C	-----	1	O-RING LARGE
16D	-----	1	SPRING
16E	-----	1	PUCKET
17	TB1017L	4	LEVER KIT (FOR ONE SECTION)
17A	-----	1	LEVER KNOB
17B	-----	1	LEVER
17C	-----	2	LEVER WASHER
17D	-----	1	LEVER CLIP
17E	-----	2	LINKAGE
17F	-----	1	LEVER PIN
17G	-----	1	ROLL PIN
17H	-----	1	LEVER BOOT
17J	-----	1	LEVER BOLT
17K	-----	1	LEVER DUST COVER
17L	-----	1	LEVER NUT
18	TB1017U	1	TIE ROD KIT
19	24214	1	O-RING, LARGE

CABLE (MANUAL) LIFT VALVE BREAKDOWN - 06502133

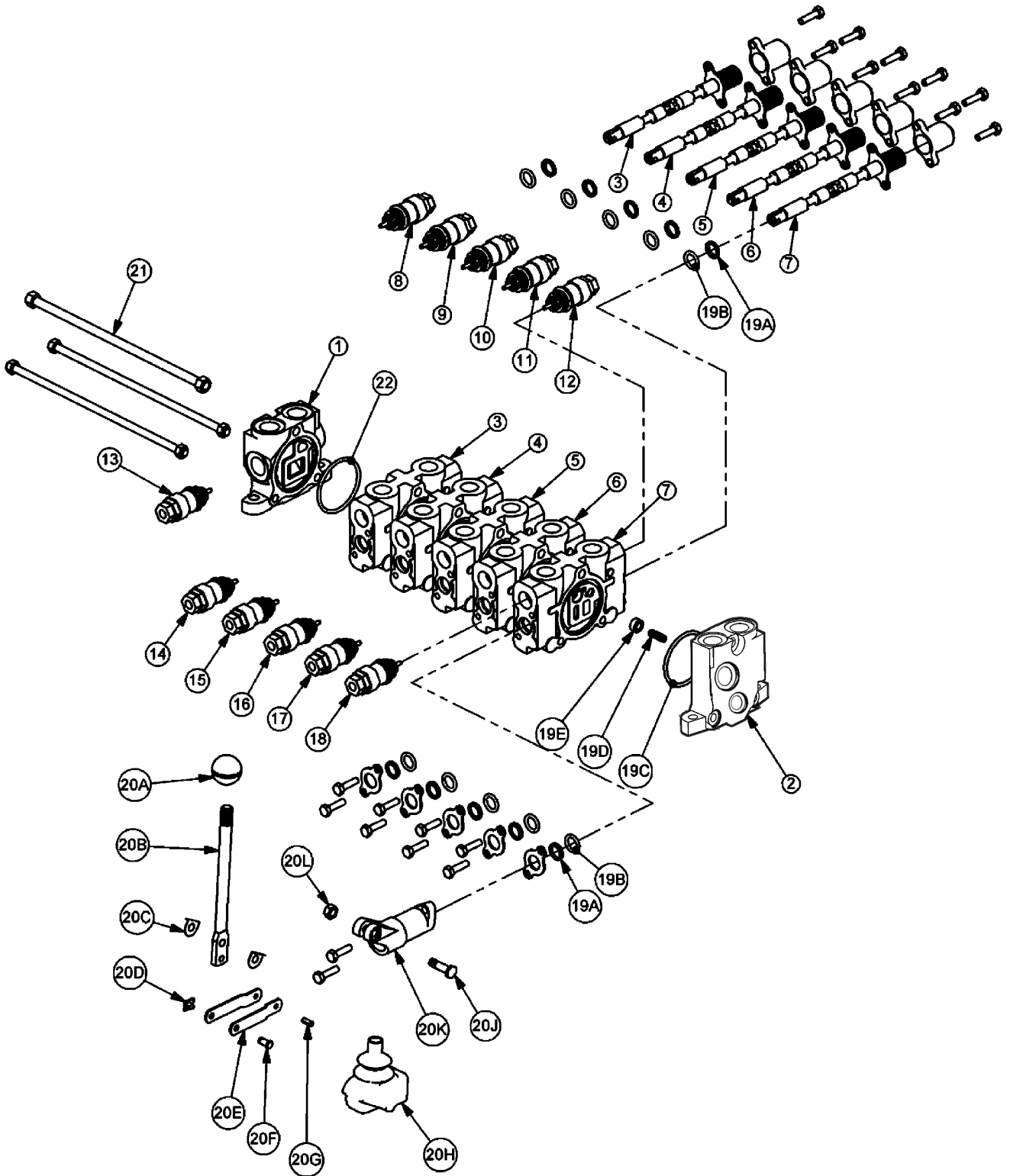

## CABLE (MANUAL) LIFT VALVE BREAKDOWN - 06502133

Continued...

ITEM	PART NO.	QTY.	DESCRIPTION
1	06502149	1	INLET END COVER
2	06502150	1	END COVER, OPEN CENTER
3	TB1017N	1	VALVE SECTION (DOUBLE ACTING, CENTER SPRING)
4	TB1017N	1	VALVE SECTION (DOUBLE ACTING, CENTER SPRING)
5	TB1017N	1	VALVE SECTION (DOUBLE ACTING, CENTER SPRING)
6	TB1017Q	1	VALVE SECTION (DOUBLE ACTING, SPRING METERED)
7	TB1017N	1	VALVE SECTION (DOUBLE ACTING, CENTER SPRING)
8	06503067	1	#10 O-RING PLUG
9	TB1017K	1	RELIEF VALVE, 2150 PSI
10	TB1017J	1	RELIEF VALVE, 1800 PSI
11	TB1017H	1	RELIEF VALVE, 1750 PSI
12	22588	1	RELIEF VALVE, 500 PSI
13	6T4209	1	#10 O-RING PLUG
14	06502003	1	RELIEF VALVE, 2500 PSI
15	TB1017K	1	RELIEF VALVE, 2150 PSI
16	TB1017F	1	RELIEF VALVE, 1500 PSI
17	TB1017H	1	RELIEF VALVE, 1750 PSI
18	22588	1	RELIEF VALVE, 500PSI
19	TB1017A	5	VALVE SEAL KIT (FOR ONE SECTION)
19A	-----	2	WIPER
19B	-----	2	O-RING SMALL
19C	-----	1	O-RING LARGE
19D	-----	1	SPRING
19E	-----	1	PUCKET
20	TB1017L	5	LEVER KIT (FOR ONE SECTION)
20A	-----	1	LEVER KNOB
20B	-----	1	LEVER
20C	-----	2	LEVER WASHER
20D	-----	1	LEVER CLIP
20E	-----	2	LINKAGE
20F	-----	1	LEVER PIN
20G	-----	1	ROLL PIN
20H	-----	1	LEVER BOOT
20J	-----	1	LEVER BOLT
20K	-----	1	LEVER DUST COVER
20L	-----	1	LEVER NUT
21	TB1017V	1	TIE ROD KIT
22	24214	1	O-RING, LARGE

# POLYCARBONATE SAFETY WINDOW

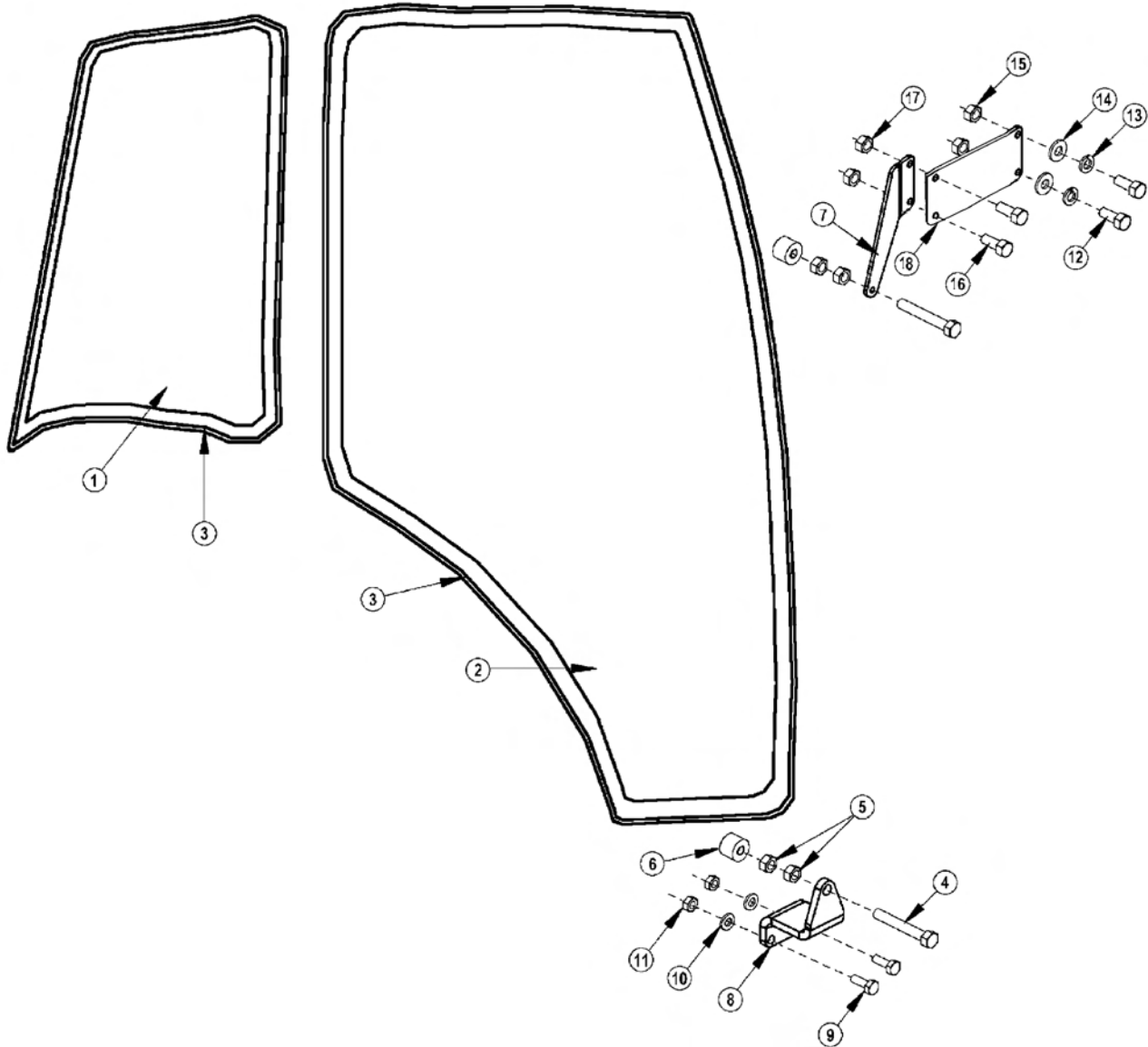



## POLYCARBONATE SAFETY WINDOW

Continued...

ITEM	PART NO.	QTY.	DESCRIPTION
1	06490014	1	POLYCARB, FRMD, REAR
2	06490013	1	POLYCARB, FRMD, DOOR
3	31965	25	TRIM SEAL (IN FEET)
4	21584	2	CAPSCREW, 5/16" X 2",NC
5	21575	6	HEX NUT, 5/16" NC
6	33477	2	VIBRATION ISOLATOR
7	06410268	1	TOP BRACKET
8	06410269	1	BOTTOM BRACKET
9	21529	2	CAPSCREW, 1/4" X 3/4",NC
10	21986	2	LOCKWASHER, 1/4"
11	21525	2	HEX NUT, 1/4",NC
12	21581	2	CAPSCREW, 5/16" X 1-1/4",NC
13	6T2619	2	LOCKWASHER, 8MM
14	34948	2	WASHER, 8MM
15	21577	2	NYLOCK NUT, 5/16",NC
---	06537005	1	3M ADHESIVE
16	6T2491	2	CAPSCREW, 8MM X 30MM, 1.25P
17	-----	-	HEX NUT (EXISTING HARDWARE)
18	06402263	1	BRKT, MIRROR, RELOCATING

# WHEEL SPACER

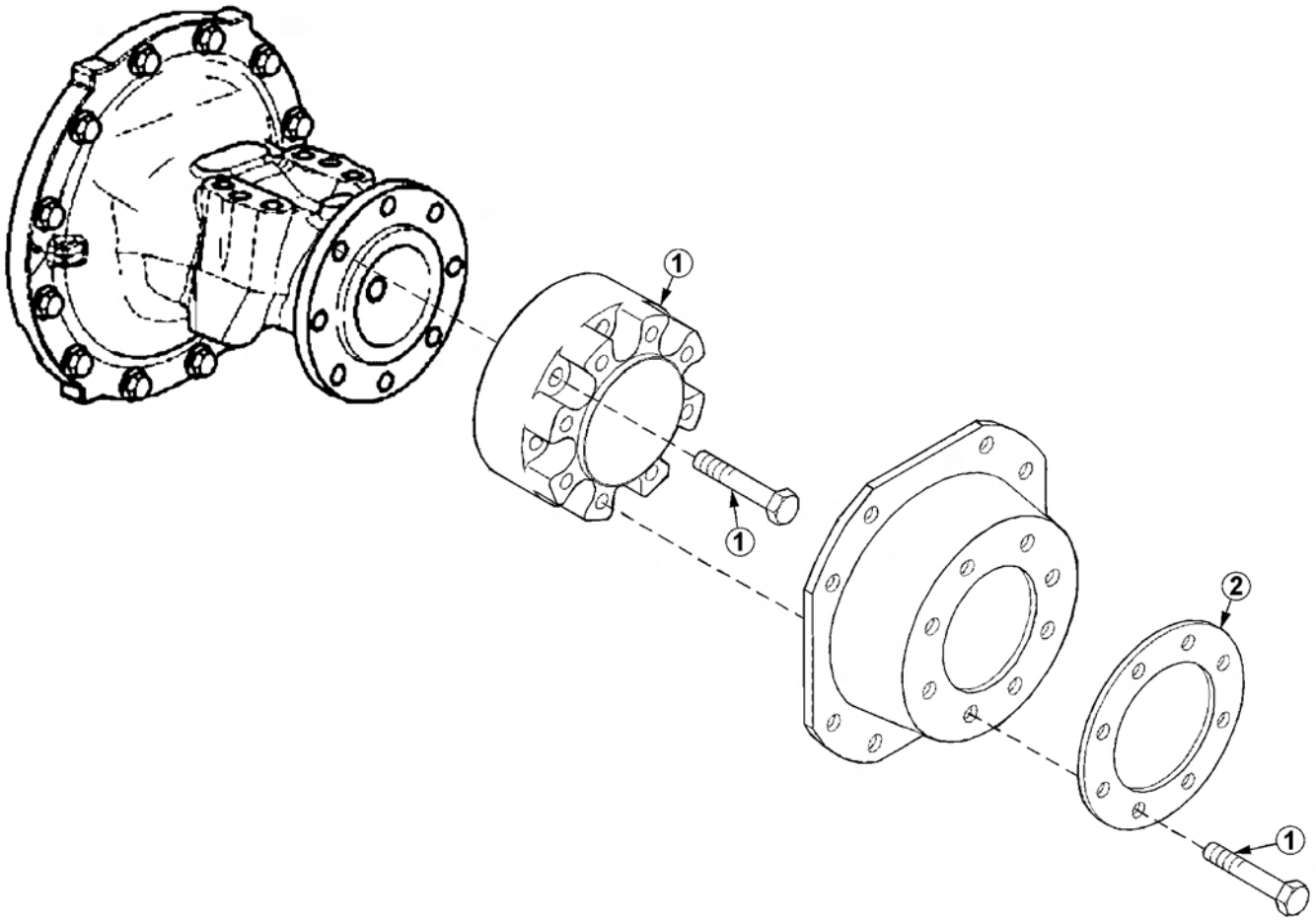

ITEM	PART NO.	QTY.	DESCRIPTION
1	06770025	1	KIT,SPCR,WHL,JD
2	06400919	1	RING,SPACER,WHEEL,JD

## WHEEL WEIGHT

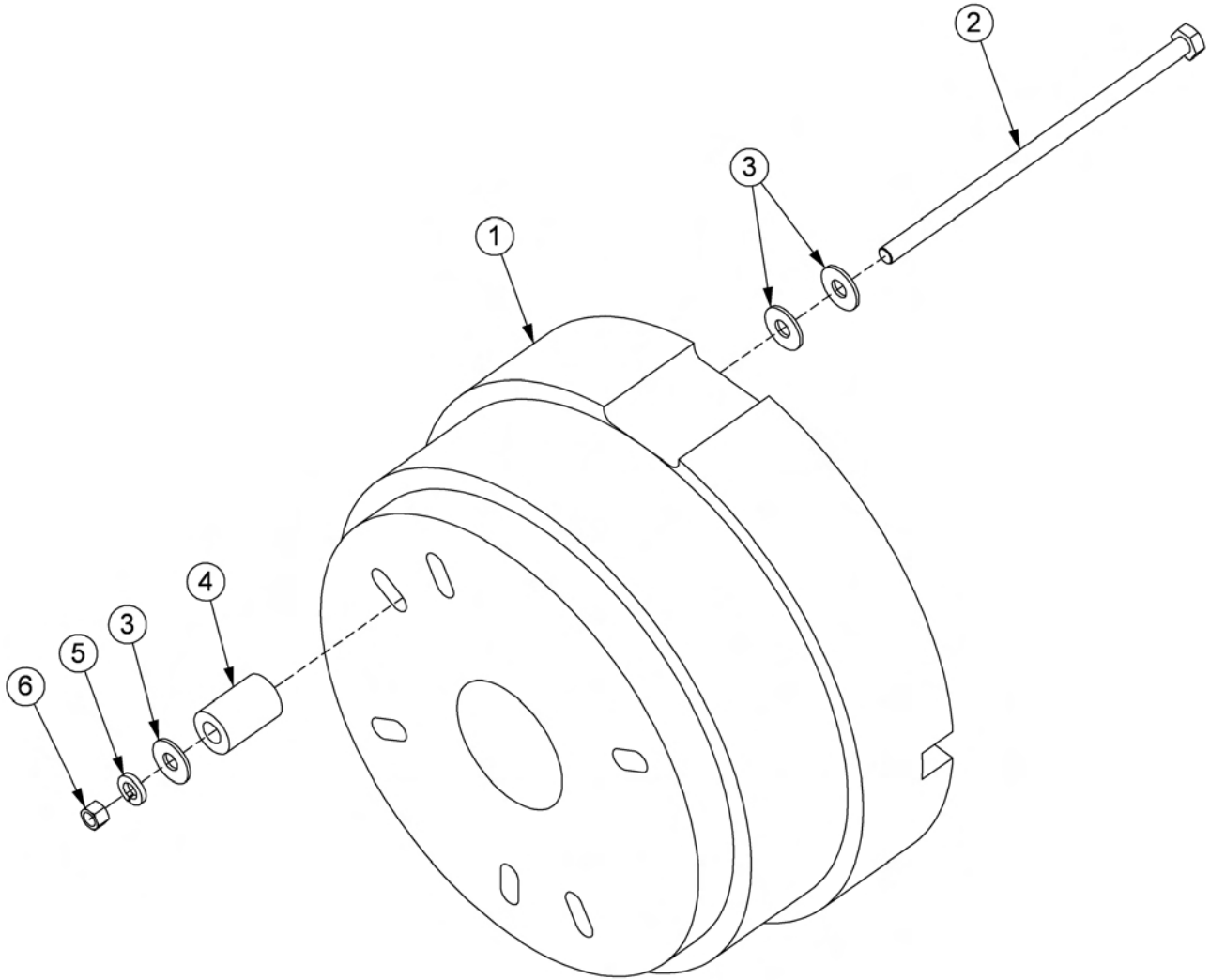

ITEM	PART NO.	QTY.	DESCRIPTION
1	02970758	1	WHEEL WEIGHT,UNIVERSAL
2	31455	3	CAPSCREW,3/4" X 17",NC
3	33626	9	FLATWASHER,3/4",USS
4	06430148	3	SPACER,2"
5	21993	3	LOCKWASHER,3/4"
6	21825	3	HEX NUT,3/4",NC

**NOTES**

**NOTES**

**COMMON REAR STOW SIDE**

**PARTS SECTION**

## PART NAME INDEX

PARTS ORDERING GUIDE.....	4
BOOM MOUNT KIT.....	5
CYLINDER TANG MOUNT.....	6
BOOM ASSEMBLY - FLAIL.....	8
BOOM ASSEMBLY - ROTARY.....	10
60IN ROTARY MOWER.....	12
60IN ROTARY DISK AND KNIVES.....	14
60IN BLADE BAR AND KNIVES.....	16
NOTES.....	17
ROTARY MOWER SPINDLE ASSEMBLY.....	18
75IN FLAIL - STANDARD ROTATION.....	20
75IN FLAIL - REVERSE ROTATION.....	22
FLAIL DRIVE ASSEMBLY.....	24
BOOM PIVOT ASSEMBLY.....	26
SLIDE ASSEMBLY.....	28
HOSE RING ASSEMBLY.....	30
2-1/2IN X 30IN CYLINDER BREAKDOWN.....	31
3IN X 15IN CYLINDER BREAKDOWN.....	32
4IN X 14IN CYLINDER BREAKDOWN.....	33
4IN X 15IN CYLINDER BREAKDOWN.....	34
NOTES 1.....	35
5 SPOOL ELECTRONIC VALVE.....	36
FRONT PUMP BREAKDOWN.....	38
ROTARY MOTOR BREAKDOWN.....	40
FLAIL MOTOR BREAKDOWN.....	42
COOLER ASSEMBLY - OPTION.....	44
RESERVOIR TANK FILTER ASSEMBLY.....	46
PUMP AND GRILL GUARD OPTIONS.....	47
MANUAL LIFT VALVE SWITCH BOX.....	48
MANUAL LIFT VALVE SWITCH BOX SCHEMATIC.....	49
ELECTRONIC LIFT VALVE SWITCH BOX.....	50
ELECTRONIC LIFT VALVE SCHEMATIC.....	51
SOLENOID SWITCH BOX AND WIRING.....	52
BRAKE VALVE ASSEMBLY.....	53
BRAKE VALVE HYDRAULIC SCHEMATIC.....	54
ELECTRICAL TROUBLESHOOTING GUIDE.....	55
HYDRAULIC TROUBLESHOOTING GUIDE.....	56
TROUBLESHOOTING.....	57
TROUBLESHOOTING - CONTINUED.....	58
FIRE SUPPRESSION SYSTEM.....	59

COMMON RSS

## PART NAME INDEX

FIRE SUPPRESSION 3-POINT MOUNT.....	60
FIRE SUPPRESSION FRONT MOUNT.....	62
FIRE SUPPRESSION SYSTEM ELECTRICAL SCHEMATIC.....	64
WETCUT.....	65
WETCUT 50 GALLON TANK - 3PNT MOUNT.....	66
WETCUT 100 OR 150 GALLON TANK - 3PNT MOUNT.....	67
WETCUT 3PNT PLUMBING - 50IN MOWERS.....	68
WETCUT 3PNT PLUMBING - LARGE MOWERS.....	70
WETCUT FRONT PLUMBING - 50IN MOWERS.....	72
WETCUT FRONT PLUMBING - LARGE MOWERS.....	74
WETCUT 50IN SPRAYER HEAD ASSEMBLY.....	76
WETCUT 60IN SPRAYER HEAD ASSEMBLY.....	78
WETCUT CABLES.....	80

## PARTS ORDERING GUIDE

The following instructions are offered to help eliminate needless delay and error in processing purchase orders for the equipment in this manual.

1. The Parts Section is prepared in logical sequence and grouping of parts that belong to the basic machine featured in this manual. Part Numbers and Descriptions are given to help locate the parts and quantities required.
2. The Purchase Order must indicate the **Name and Address** of the person or organization ordering the parts, **who should be charged**, and if possible, the **serial number of the machine** for which the parts are being ordered.
3. The purchase order must clearly list the **quantity of each part**, the complete and correct **part number**, and the basic **name of the part**.
4. The manufacturer reserves the right to substitute parts where applicable.
5. Some parts may be unlisted items which are special production items not normally stocked and are subject to special handling. Request a quotation for such parts before sending a purchase order.
6. The manufacturer reserves the right to change prices without prior notice.

NOTE: When ordering replacement decals, refer to the part numbers and descriptions listed in the safety section in the front of this manual.

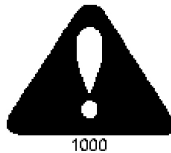

For maximum safety and to guarantee optimum product reliability, always use genuine **Tiger** replacement parts. The use of inferior replacement parts may cause premature or catastrophic failure which could result in serious injury or death.

Direct any questions regarding parts to:

**Tiger Corporation**  
3301 N. Louise Ave.  
Sioux Falls, SD 57107  
1-800-843-6849  
1-605-336-7900



## BOOM MOUNT KIT

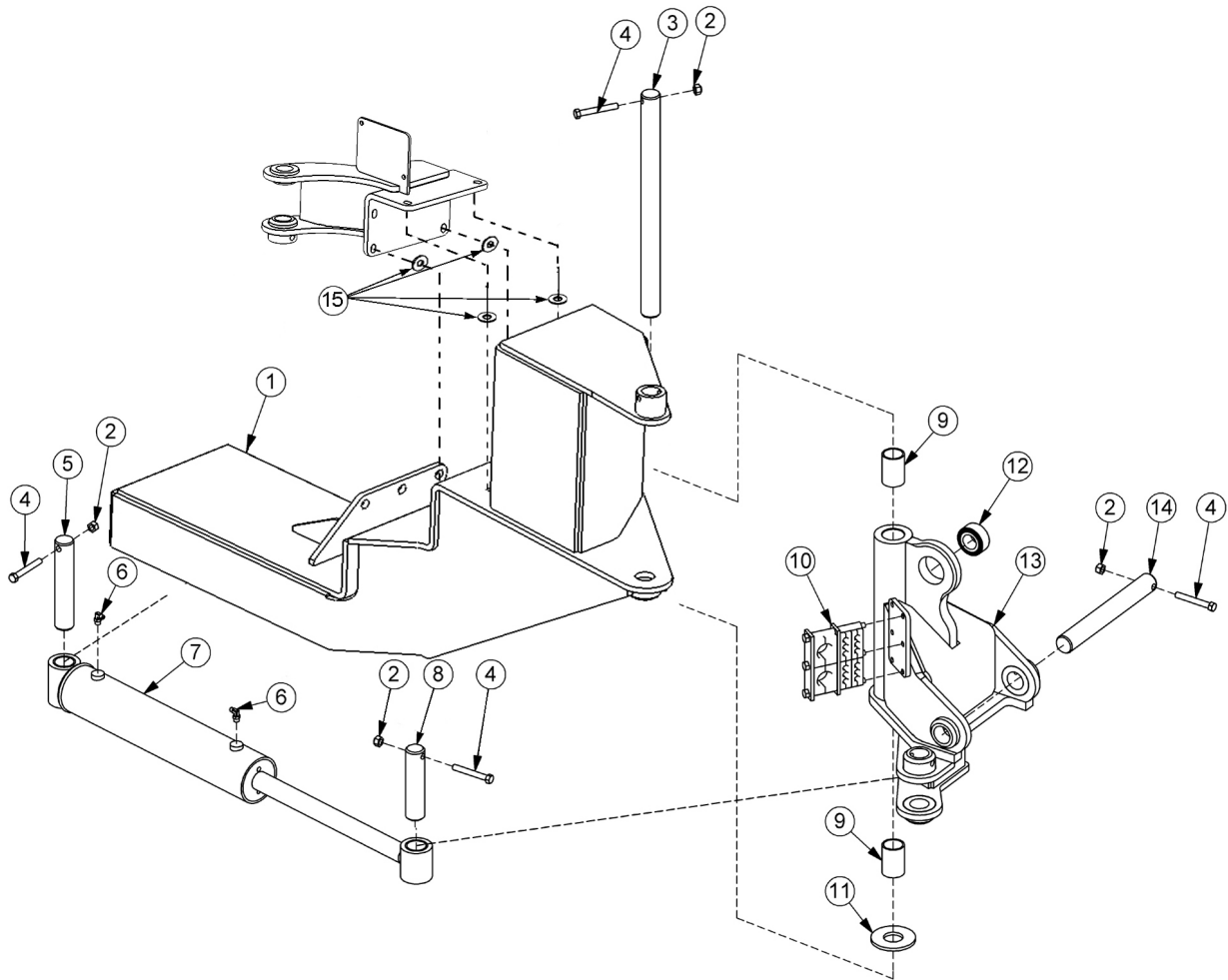

ITEM	PART NO.	QTY.	DESCRIPTION
1	-----	-	MAIN FRAME *REFER TO TRACTOR MOUNT KIT PAGE
2	21677	4	NYLOCK NUT,7/16",NC
3	06420013	1	PIN,1-1/2" X 19-7/8"
4	21688	4	CAPSCREW,7/16" X 3-1/4",NC
5	06420124	1	PIN,1-1/2" X 7-13/16"
6	32810	2	ELBOW,3/8" MJ X 1/2" MOR ADJ
7	06501026	1	CYLINDER,3" X 15"
8	06420099	1	PIN,1-1/2" X 6-3/16"
9	06520411	2	BEARING,1-1/2" ID X 2-1/2",COMP
10	35131	1	HOSE CLAMP
11	06520049	1	BEARING,1-1/2" ID X 1/4",COMP
12	-----	-	BEARING,SPHERICAL *NOT FOR SALE
---	06700114	1	SWIVEL ASSEMBLY,COMPLETE
13	06310115	1	SWIVEL,WELDMENT
14	06420022	1	PIN,1-1/2" X 12"
15	27938	4	MACHINED BUSHING (AS NEEDED)

COMMON RSS

# CYLINDER TANG MOUNT

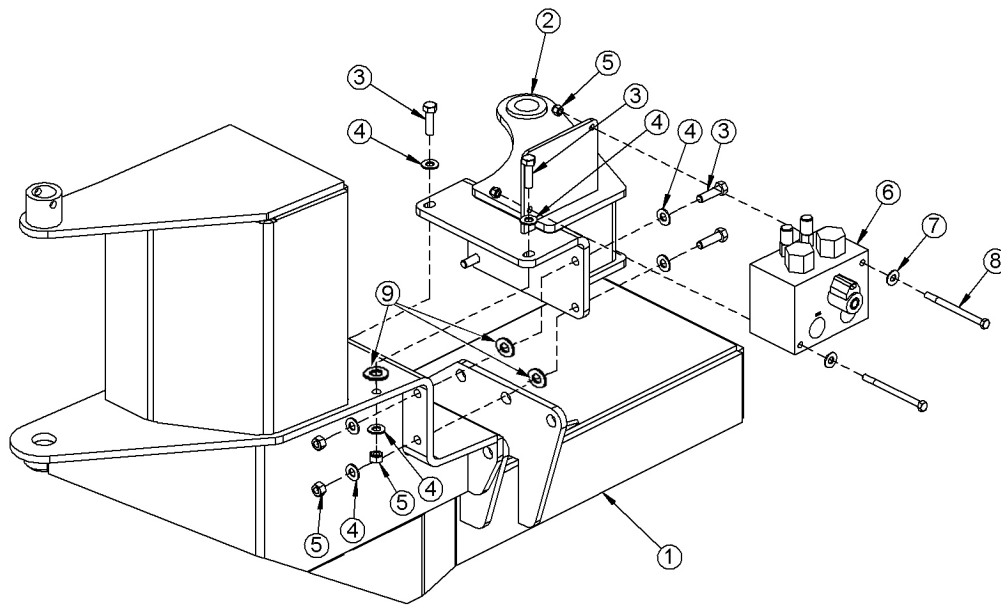

## CYLINDER TANG MOUNT

Continued...

ITEM	PART NO.	QTY.	DESCRIPTION
1	-----	-	MAIN FRAME *REFER TO TRACTOR MOUNT KIT
2	06300242	1	CYLINDER TANG
3	6T1027	6	CAPSCREW,1/2" X 1-3/4",NC
4	06533004	12	FLATWASHER,1/2",SAE
5	21727	6	NYLOCK NUT,1/2",NC
6	-----	-	BRAKE VALVE *REFER TO TRACTOR MOUNT KIT
7	-----	-	FLATWASHER *REFER TO TRACTOR MOUNT KIT
8	-----	-	CAPSCREW *REFER TO TRACTOR MOUNT KIT
9	27938	4	BUSHING, MACHINED (AS NEEDED)

COMMON RSS

# BOOM ASSEMBLY - FLAIL

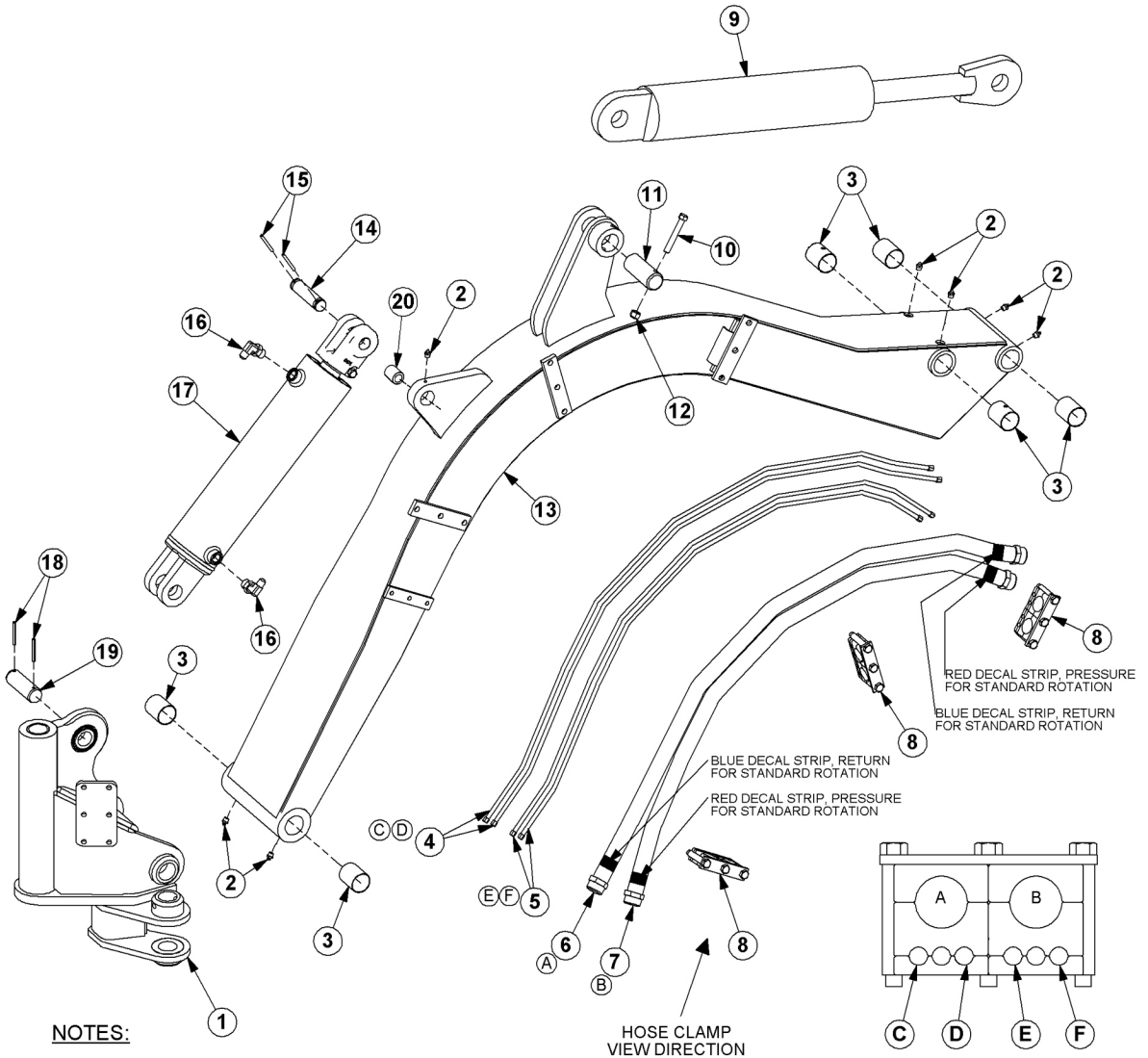

**NOTES:**

1. RETURN AND PRESSURE HOSES ON FLAIL ARE REVERSED FOR REVERSE ROTATION BOOM FLAILS
2. IMPORTANT: ALIGN GREASE HOLE IN BEARING (ITEM 3) WITH GREASE ZERK IN BOOM. MAINTAIN ALIGNMENT DURING BEARING INSTALLATION
3. GREASE (ITEM 4) HINGE PIN ZERKS ON BOOM AFTER ASSEMBLY, ONCE UNDER LOAD WITH BOOM ELEVATED AND AGAIN AT REST WITH BOOM SUPPORTED

- A - MOWER RETURN
- B - MOWER PRESSURE
- C - DECK ROLL CYLINDER BUTT
- D - DECK ROLL CYLINDER GLAND
- E - DECK SLIDE CYLINDER INBOARD
- F - DECK SLIDE CYLINDER OUTBOARD

## BOOM ASSEMBLY - FLAIL

Continued...

ITEM	PART NO.	QTY.	DESCRIPTION
1	-----	-	SWIVEL ASSY *REFER TO BOOM MOUNT KIT PAGE
2	6T3211	7	GREASE ZERK,1/8"
3	32321	6	BEARING
4	06500723	2	HOSE,1/4" X 52"
5	06500724	2	HOSE,1/4" X 70"
6	-----	1	HOSE *REFER TO TRACTOR SPECIFIC PARTS
7	-----	1	HOSE *REFER TO TRACTOR SPECIFIC PARTS
8	06505116	3	HOSE CLAMP
9	32365	1	CYLINDER,4" X 15",WELDED
10	21687	1	CAPSCREW,7/16" X 3",NC
11	32375	1	PIN,1-1/2"OD
12	21677	1	NYLOCK NUT,7/16"
13	06700000	1	BOOM ASSEMBLY,COMPLETE
---	35331	1	BOOM WELDMENT
14	TB1033	1	PIN,CLEVIS
15	06537021	2	ROLL PIN,5MM
16	32810	2	ELBOW
17	06501028	1	CYLINDER,4" X 14",WELDED
18	TB1023	2	ROLL PIN,7/16"
19	06420100	1	PIN,1-1/4"OD
20	TB3010	1	SPLIT BUSHING

COMMON RSS

# BOOM ASSEMBLY - ROTARY

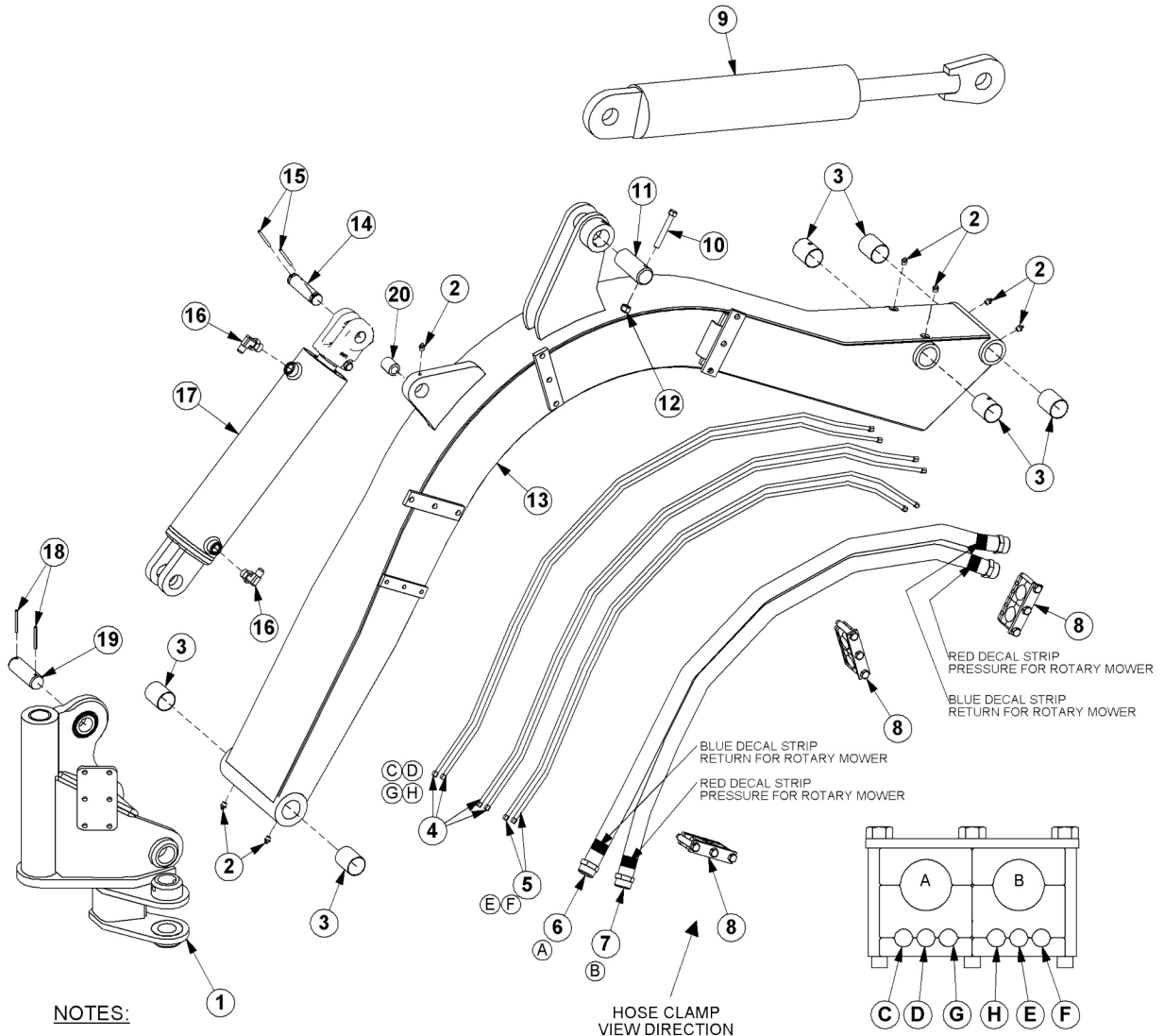

**NOTES:**

1. IMPORTANT: ALIGN GREASE HOLE IN BEARING (ITEM 3) WITH GREASE ZERK IN BOOM. MAINTAIN ALIGNMENT DURING BEARING INSTALLATION
2. GREASE (ITEM 4) HINGE PIN ZERKS ON BOOM AFTER ASSEMBLY, ONCE UNDER LOAD WITH BOOM ELEVATED AND AGAIN AT REST WITH BOOM SUPPORTED

- A - MOWER RETURN
- B - MOWER PRESSURE
- C - DECK ROLL CYLINDER BUTT
- D - DECK ROLL CYLINDER GLAND
- E - SHIELD CYLINDER BUTT
- F - SHIELD CYLINDER GLAND
- G - DECK SLIDE CYLINDER INBOARD
- H - DECK SLIDE CYLINDER OUTBOARD

## BOOM ASSEMBLY - ROTARY

Continued...

ITEM	PART NO.	QTY.	DESCRIPTION
1	-----	-	SWIVEL ASSY *REFER TO BOOM MOUNT KIT PAGE
2	6T3211	7	GREASE ZERK,1/8"
3	32321	6	BEARING
4	06500723	4	HOSE,1/4" X 52"
5	06500724	2	HOSE,1/4" X 70"
6	-----	1	HOSE *REFER TO TRACTOR SPECIFIC PARTS
7	-----	1	HOSE *REFER TO TRACTOR SPECIFIC PARTS
8	06505116	3	HOSE CLAMP
9	32365	1	CYLINDER,4" X 15",WELDED
10	21687	1	CAPSCREW,7/16" X 3",NC
11	32375	1	PIN,1-1/2"OD
12	21677	1	NYLOCK NUT,7/16"
13	06700000	1	BOOM ASSEMBLY,COMPLETE
---	35331	1	BOOM WELDMENT
14	TB1033	1	PIN,CLEVIS
15	06537021	2	ROLL PIN,5MM
16	32810	2	ELBOW
17	06501028	1	CYLINDER,4" X 14",WELDED
18	TB1023	2	ROLL PIN,7/16"
19	06420100	1	PIN,1-1/4"OD
20	TB3010	1	SPLIT BUSHING

COMMON RSS

# 60IN ROTARY MOWER

LINK TO THE SHIELD (OPTIONAL)

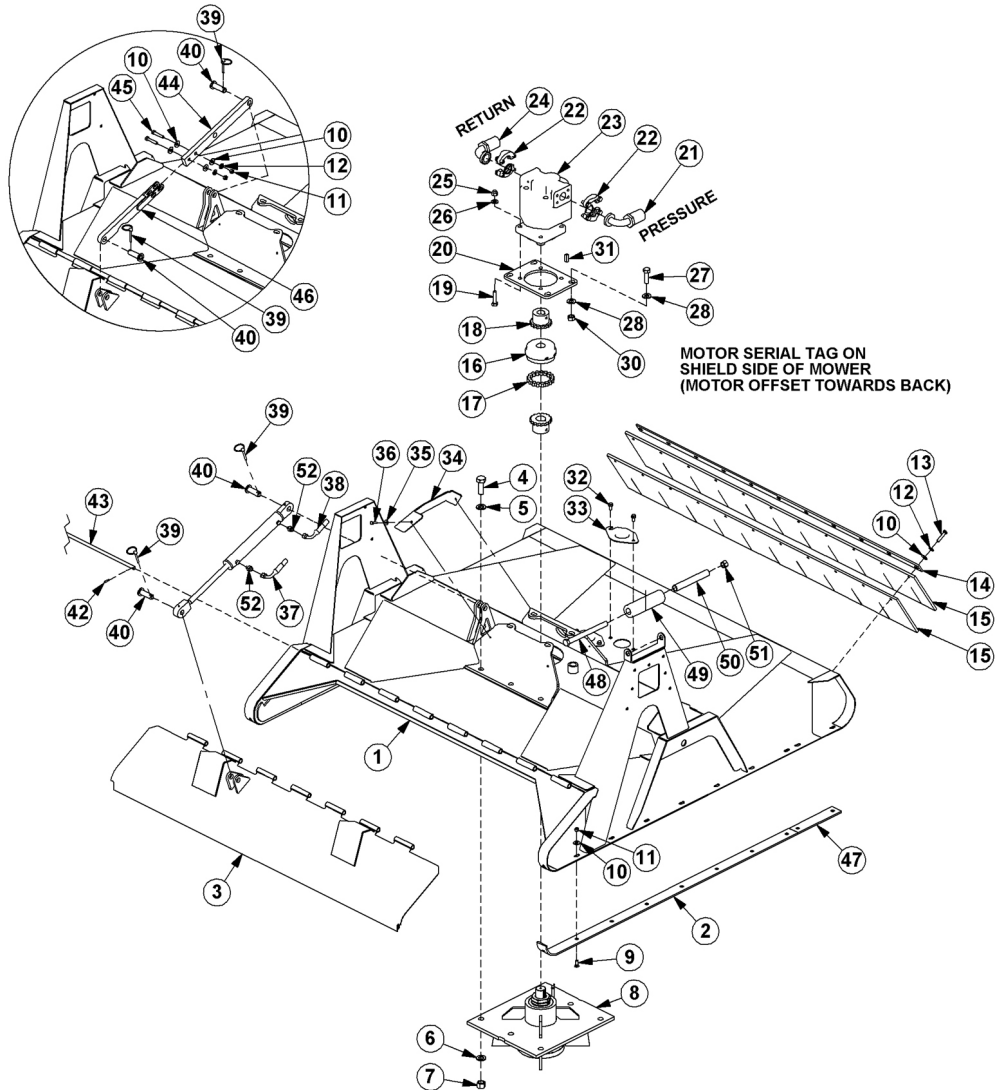

ITEM	PART NO.	QTY.	DESCRIPTION
1	06320183	1	DECK,WLDMNT,60" RTRY,RSS
2	33777	2	SKID SHOE,RTRY
3	06320162	1	SHIELD,60"RTRY
4	33879	6	CAPSCREW,3/4" X 2-1/4",NF,GR 8
5	33880	6	FLATWASHER,3/4",GR 8,SAE
6	21993	6	LOCKWASHER,3/4",GR 8
7	6T2413	6	HEX NUT,3/4",NF,GR 8
8	6T1024H5	1	SPINDLE ASSY,CPLT,HD,5/8 HOLES
9	6T2270	16	PLOW BOLT,3/8" X 1",NC
10	22016	33	FLATWASHER,3/8"
11	21625	20	HEX NUT,3/8",NC
12	21988	11	LOCKWASHER,3/8"

COMMON RSS



## 60IN ROTARY MOWER

**Continued...**

<b>ITEM</b>	<b>PART NO.</b>	<b>QTY.</b>	<b>DESCRIPTION</b>
13	21633	11	CAPSCREW,3/8" X 1-3/4",NC
14	6T0823	1	FLAP RETAINER,60" RTRY
15	06520238	2	FLAP,60" RTRY
16	6T1033	1	COUPLER COVER
17	6T1029	1	COUPLER CHAIN
18	21223	1	SPROCKET
19	21733	4	CAPSCREW,1/2" X 2",NC
20	33776	1	MOTOR MOUNT,PLATE,RTRY
21	06500458	1	HOSE,1" X 95" (PRESSURE)
22	TF4852	2	FLANGE KIT,#20
23	06504011	1	MOTOR
24	06500613	1	HOSE,1" X 87" (RETURN)
25	21727	4	NYLOCK NUT,1/2",NC
26	06533004	4	FLATWASHER,1/2"
27	6T2290	4	CAPSCREW,5/8" X 2",NF,GR 8
28	33764	8	FLATWASHER,5/8",GR 8,SAE
29	21992	4	LOCKWASHER,5/8"
30	6T2408	4	HEX NUT,5/8",NF
31	TF1124	1	SQUARE KEY
32	33881	4	CAPSCREW,FLG,3/8" X 3/4",NC
33	33779	1	PLATE,COVER,KNF HOLE
34	06410439	2	COVER
35	22014	2	FLATWASHER,1/4"
36	21530	2	CAPSCREW,1/4" X 1",NC
37	06500141	1	HOSE,1/4" X 92"
38	06500443	1	HOSE,1/4" X 83"
39	RD1032	2	LYNCH PIN
40	33984	2	PIN,SHIELD
41	33785	1	CYLINDER,1-1/2" X 8"
42	6T3017	2	ROLLPIN
43	06420139	1	HINGE PIN,60" RTRY
44	33772	1	LINK,SHIELD,RTRY
45	21634	2	CAPSCREW,3/8" X 2",NC
46	33773	1	LINK 2,SHIELD,RTRY
47	06401245	2	SKID SHOE,TRB60
48	06530226	1	CAPSCREW,3/4" X 8-1/2",NC
49	35340	1	ROLLER
50	35339	1	BUSHING
51	21825	1	HEX NUT,3/4",NC
52	06503057	2	ADAPTER,1/4"MOR X 3/8"MJ

COMMON RSS

# 60IN ROTARY DISK AND KNIVES

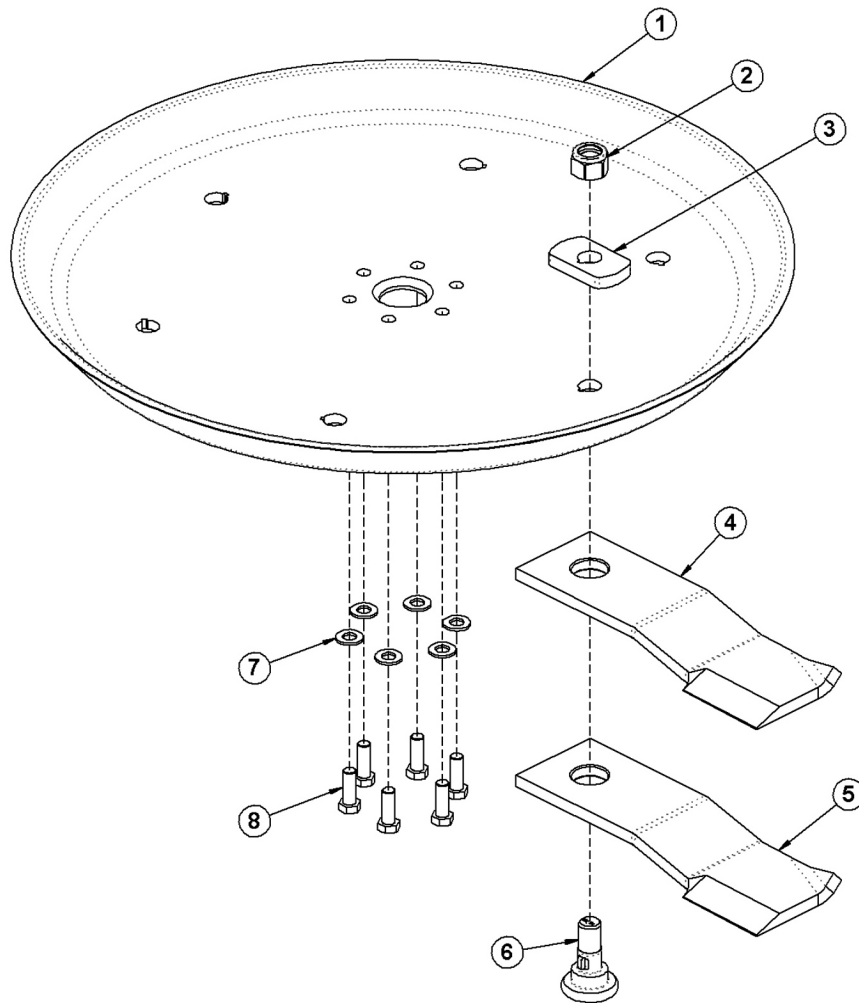

COMMON RSS

## 60IN ROTARY DISK AND KNIVES

Continued...

ITEM	PART NO.	QTY.	DESCRIPTION
---	27167	1	BOLT KIT (INCLUDES ITEMS 7, 8 & LOCTITE)
1	34876	1	BLADE MOUNTING DISK
2	6T1023R	2	NYLOCK NUT,1-1/8",NF
3	34878	2	SPACER
4	34684	2	STANDARD GRASS KNIFE
5	34685	2	HIGH SUCTION GRASS KNIFE (OPTIONAL)
6	34497	2	KNIFE MOUNTING BOLT
7	25270	6	FLATWASHER,5/8",GR8,USS
8	6T2259	6	CAPSCREW,5/8" X 1-3/4",NF
---	6T1825	1	LOCTITE (USED ON ITEM 8)
----	33893	1	KNIFE KIT (ITEMS 2,4 & 6)

COMMON RSS

## 60IN BLADE BAR AND KNIVES

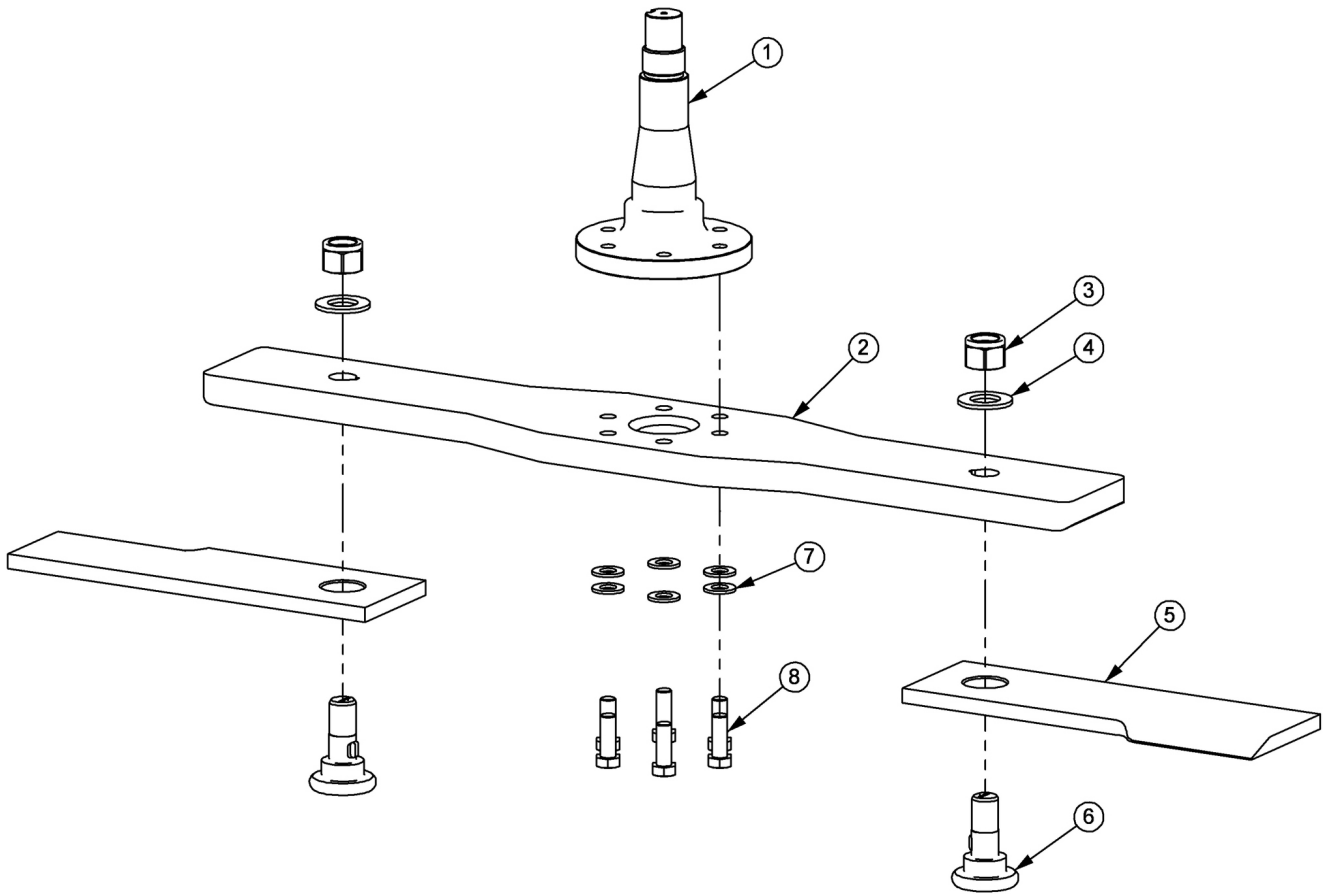

ITEM	PART NO.	QTY.	DESCRIPTION
1	PT1018H5	1	SPINDLE
2	06400690	1	BAR, BLADE, RTRY60
3	6T1023R	2	KNIFE MTG NUT, 1-1/8, NYLOCK, NF
4	06533002	2	FLATWASHER, 1-1/8, GR8
5	06521001	2	KNIFE, TRB50, 5/8
6	06538000	2	KNIFE MTG BOLT, 5/8 SHOULDER
7	33764	6	FLATWASHER, 5/8, GR 8, SAE
8	6T2259	6	CAPSCREW, 5/8 X 1-3/4, NF, GR8

COMMON RSS

**NOTES**

**NOTES**

# ROTARY MOWER SPINDLE ASSEMBLY

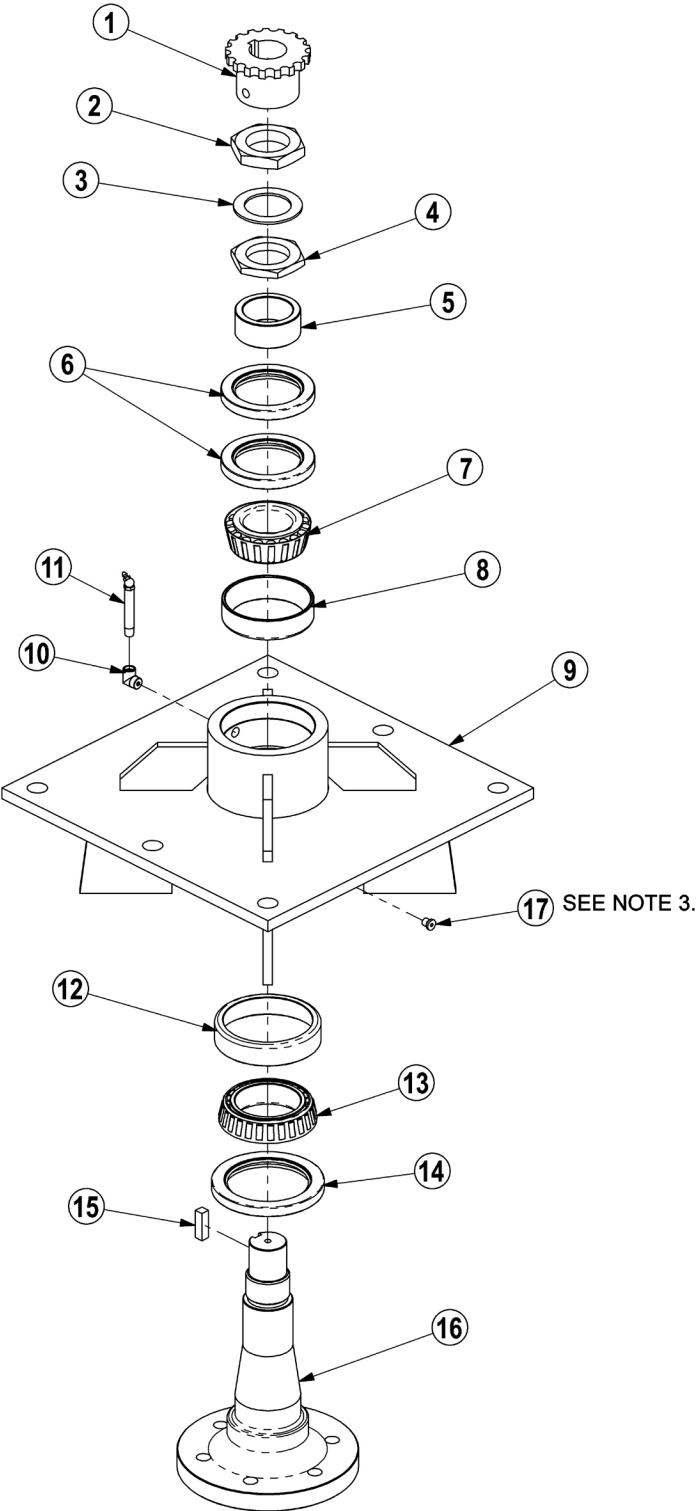

**NOTES:**

- 1. FREEPLAY: .001" - .003"
- 2. GREASE: FILL WITH MOBILITH SHC 220.
- 3. APPLY LOCTITE "271" TO O-RING PLUG THRDS.

## ROTARY MOWER SPINDLE ASSEMBLY

Continued...

ITEM	PART NO.	QTY.	DESCRIPTION
---	6T1024H5	-	SPINDLE ASSEMBLY COMPLETE
1	6T1031	1	SPROCKET
2	6T1016	1	BEARING LOCK NUT - THICK
3	22596	1	JAM WASHER
4	6T1015	1	BEARING ADJUSTMENT NUT - THIN
5	6T1014	1	BEARING ADJUSTMENT SLEEVE
6	6T1011	1	UPPER SEAL - SET OF 2
7	6T1012	1	BEARING CONE
8	6T1013	1	BEARING CUP
9	6T1010H	1	SPINDLE HOUSING
10	30570	1	FITTING STREET ELBOW
11	33990	1	GREASE ZERK
12	6T1013H	1	BEARING CUP
13	6T1012H	1	BEARING CONE
14	6T1011H	1	LOWER SEAL
15	6T1019	1	SPINDLE KEY
16	PT1018H-5	1	SPINDLE
17	06503064	1	O-RING PLUG, 1/8"
---	31771	-	SPINDLE REBUILD KIT (INCLUDES ITEMS 2 - 8 AND 12 - 15)

COMMON RSS

# 75IN FLAIL - STANDARD ROTATION

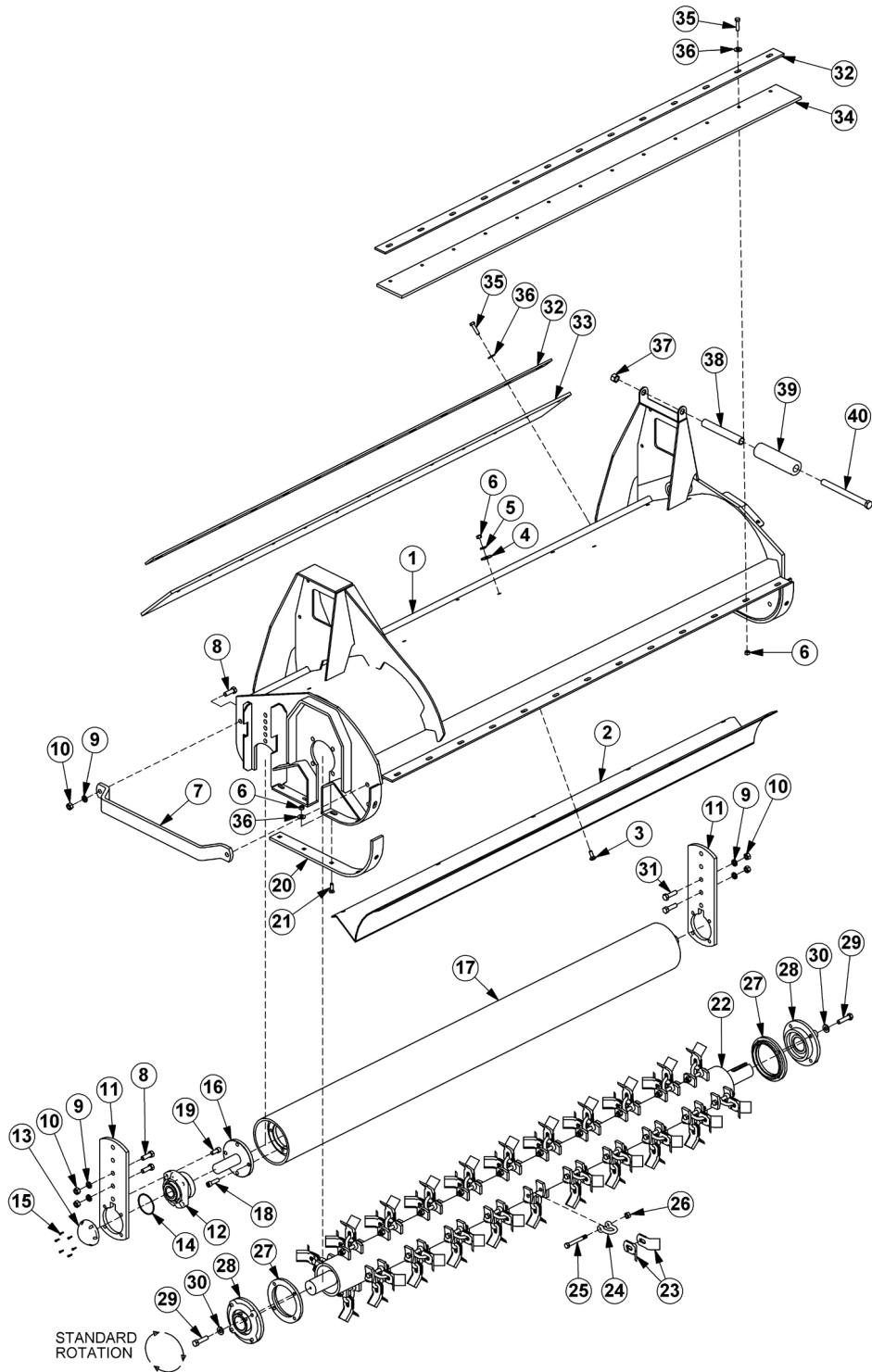

ITEM	PART NO.	QTY.	DESCRIPTION
1	06320185	1	BONNET,75",STD,RSS
2	28737	1	BAFFLE,75",STD

COMMON RSS



## 75IN FLAIL - STANDARD ROTATION

Continued...

ITEM	PART NO.	QTY.	DESCRIPTION
3	6T2283	10	CARRIAGE BOLT,3/8" X 1",NC
4	6T2615	10	WASHER,FENDER,3/8"
5	21988	10	LOCKWASHER,3/8"
6	21625	46	HEX NUT,3/8",NC
7	27975A	1	GUARD,CUTTERSHAFT
8	21731	4	CAPSCREW,1/2" X 1-1/2",NC
9	21990	6	LOCKWASHER,1/2"
10	21725	6	HEX NUT,1/2",NC
11	28735	2	GROUND ROLLER ADJ BRKT,STD DTY
12	06520028	2	BEARING,FLANGE,1-3/8,GRNDRLR
13	06520027	2	CAP,BEARING,GRNDRLR
14	06520029	2	O-RING,2-3/4 X 3/32",AS568A-148
15	06530001	12	CAPSCREW,SKT HD,8-32 X 1/2",SS
16	TF1045B	2	STUB SHAFT,GROUND ROLLER
17	28738	1	GROUND ROLLER,75"
18	6T2330	8	CAPSCREW,SKT HD,7/16" X 1-1/2",NC
19	6T2331	8	CAPSCREW,SKT HD,7/16" X 1",NC
20	28086A	2	SKID SHOE,STD DUTY REAR FLAIL
21	30013	10	PLOW BOLT,3/8" X 1-1/4",NC,GR5
---	28747	-	CUTTERSHAFT ASSY,STANDARD
22	28643B	1	CUTTERSHAFT,75"
23	33713	80	KNIFE,FLAIL,SHORT
24	TF1020	40	KNIFE MTG CLEVIS,FLAIL
25	34011	40	CAPSCREW,7/16" X 3-7/16",NC,GR8
26	21677	40	NYLOCK NUT,7/16",NC
---	06200639	-	STRING GUARD KIT,SD (ITEMS 27,29,30)
27	33863	2	STRING GUARD,STD
28	28683	2	BEARING,FLANGE,1-15/16",STD,TSF
29	06530217	8	CAPSCREW,1/2" X 2",NC,L9
30	06533006	8	FLATWASHER,1/2",SAE,L9
31	21732	2	CAPSCREW,1/2" X 1-3/4",NC
32	TF1029	2	BAR,FLAP,TSF/TBF,75"
33	TF1016	1	FLAP,DEFLECTOR,TSF,75"
34	06520242	1	FLAP,75",FRONT
35	21632	26	CAPSCREW,3/8" X 1-1/2",NC
36	22016	36	FLATWASHER,3/8"
37	21825	1	HEX NUT,3/4",NC
38	35339	1	BUSHING
39	35340	1	ROLLER
40	06530226	1	CAPSCREW,3/4" X 8-1/2",NC

COMMON RSS

# 75IN FLAIL - REVERSE ROTATION

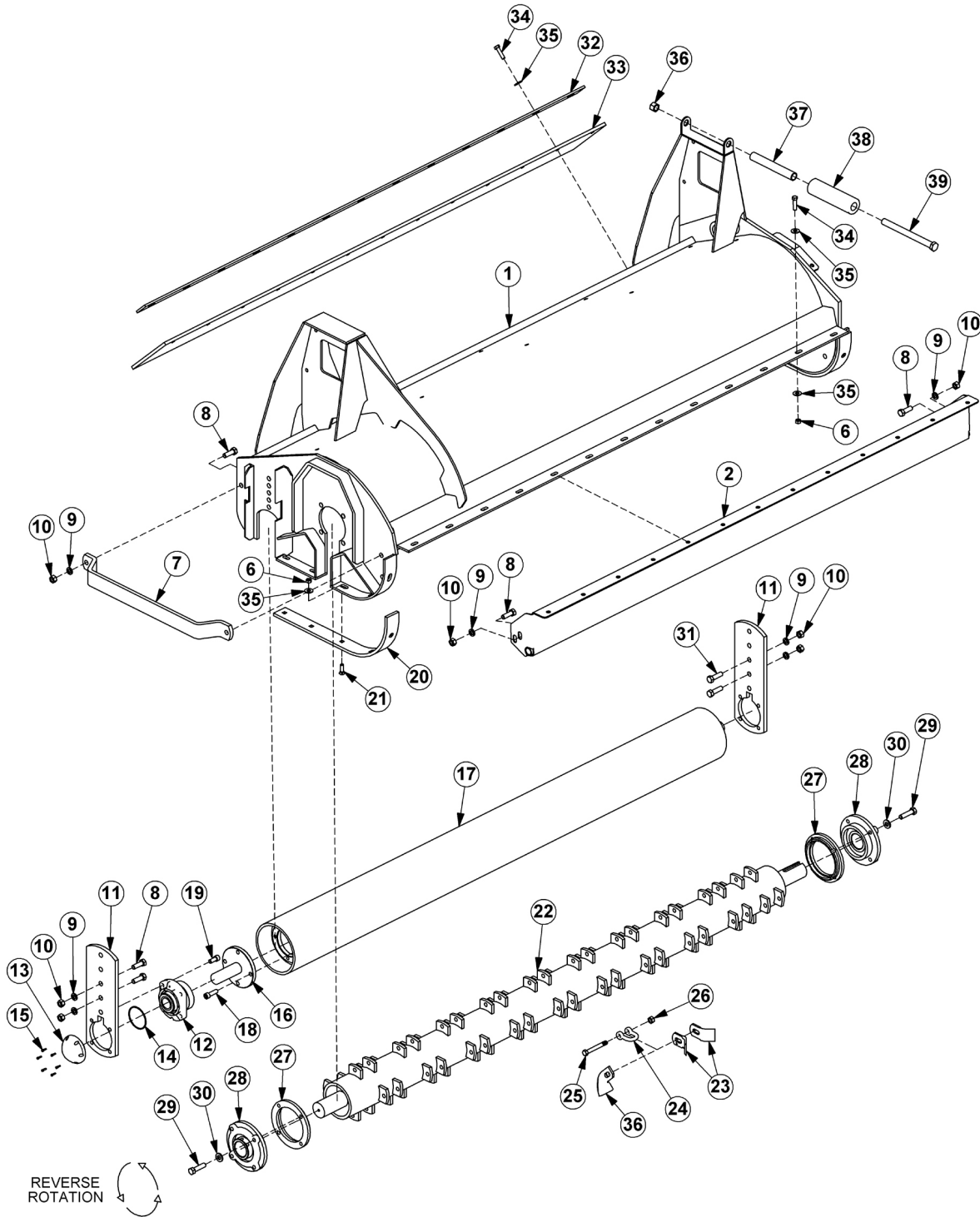

ITEM	PART NO.	QTY.	DESCRIPTION
1	06320185	1	BONNET,75,STD,RSS
2	28968A	1	TRASH GUARD,75"

COMMON RSS

## 75IN FLAIL - REVERSE ROTATION

Continued...

ITEM	PART NO.	QTY.	DESCRIPTION
3	6T2283	10	CARRIAGE BOLT,3/8" X 1",NC
4	6T2615	10	WASHER,FENDER,3/8"
5	21988	10	LOCKWASHER,3/8"
6	21625	36	HEX NUT,3/8",NC
7	27975A	1	GUARD,CUTTERSHAFT
8	21731	6	CAPSCREW,1/2" X 1-1/2",NC
9	21990	8	LOCKWASHER,1/2"
10	21725	8	HEX NUT,1/2",NC
11	28735	2	GROUND ROLLER ADJ BRKT,STD DTY
12	06520028	2	BEARING,FLANGE,1-3/8",GRNDRLR
13	06520027	2	CAP,BEARING,GRNDRLR
14	06520029	2	O-RING,2-3/4" X 3/32",AS568A-148
15	06530001	12	CAPSCREW,SKT HD,8-32 X 1/2",SS
16	TF1045B	2	STUB SHAFT,GROUND ROLLER
17	28738	1	GROUND ROLLER,75"
18	6T2330	8	CAPSCREW,SKT HD,7/16" X 1-1/2",NC
19	6T2331	8	CAPSCREW,SKT HD,7/16" X 1",NC
20	28086A	2	SKID SHOE,STD DUTY REAR FLAIL
21	30013	9	PLOW BOLT,3/8" X 1-1/4",NC,GR5
---	28747	-	CUTTERSHAFT ASSY,STANDARD (22, 23, 24, 25 & 26)
----	28748	-	CUTTERSHAFT ASSY,SMOOTH (22, 23, 24, 25 & 37)
22	28643B	1	CUTTERSHAFT,75"
23	33713	80	FLAIL KNIVES (STANDARD CUT)
24	TF1020	40	KNIFE MTG CLEVIS,FLAIL
25	34011	40	CAPSCREW,7/16" X 3-7/16",NC,GR8
26	21677	40	NYLOCK NUT,7/16",NC
---	06200639	-	STRING GUARD KIT, SD (ITEMS 27,29,30)
27	33863	2	STRING GUARD,STD
28	28683	2	BEARING,FLANGE,1-15/16",STD,TSF
29	06530217	8	CAPSCREW,1/2" X 2",NC,L9
30	06533006	8	FLATWASHER,1/2",SAE,L9
31	21732	2	CAPSCREW,1/2" X 1-3/4",NC
32	TF1029	1	BAR,FLAP,TSF/TBF,75"
33	TF1016	1	FLAP,DEFLECTOR,TSF,75"
34	21632	22	CAPSCREW,3/8" X 1-1/2",NC
35	22016	49	FLATWASHER,3/8"
36	28184A	40	FLAIL KNIVES (SMOOTH CUT)
37	35339	1	BUSHING
38	35340	1	ROLLER
39	06530226	1	CAPSCREW,3/4" X 8-1/2",NC

COMMON RSS

# FLAIL DRIVE ASSEMBLY

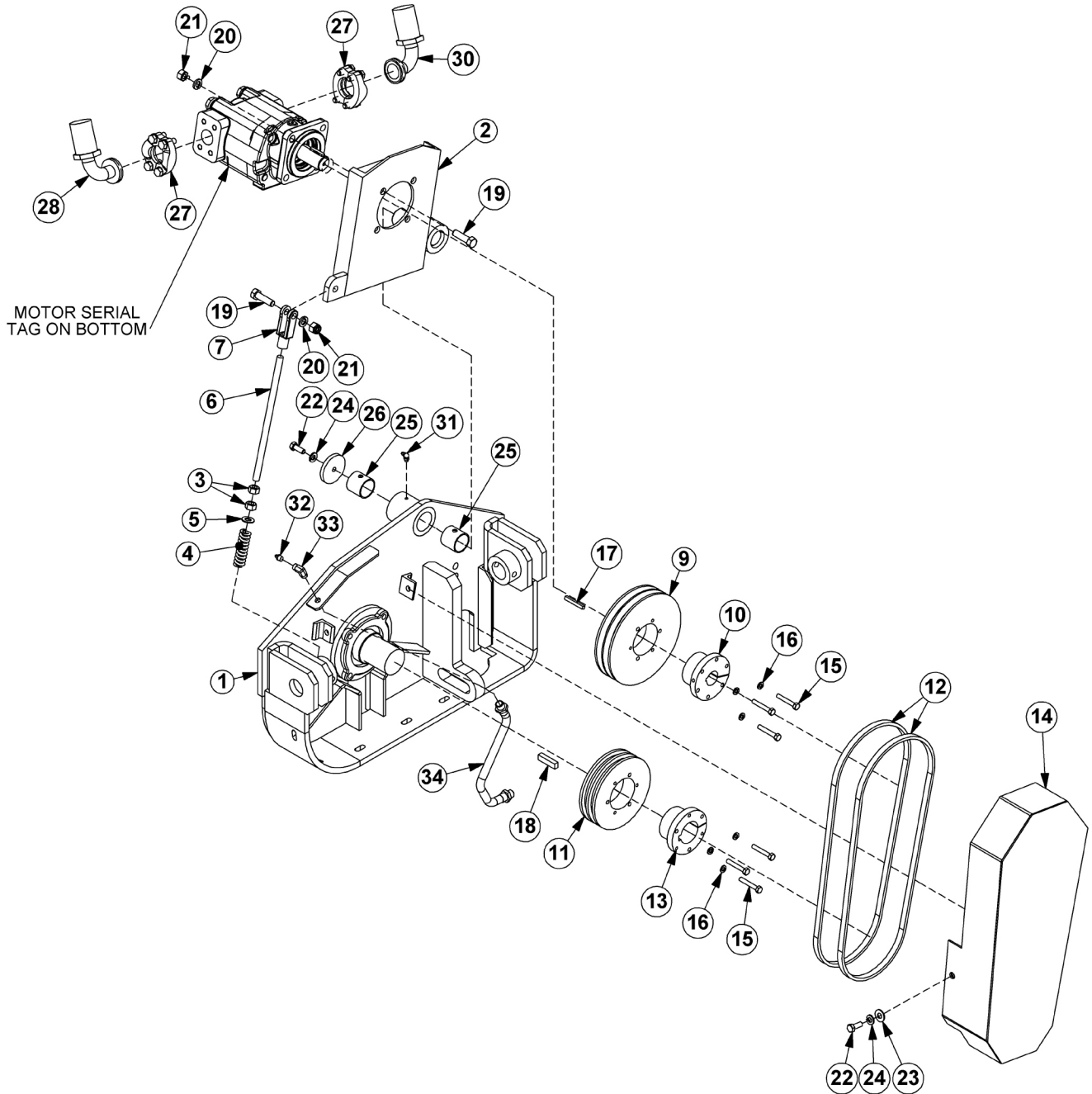

COMMON RSS

## FLAIL DRIVE ASSEMBLY

Continued...

ITEM	PART NO.	QTY.	DESCRIPTION
1	-----	-	BONNET *REFER TO HEAD PARTS
2	32287	1	MOTOR CHANNEL
3	21700	2	HEX NUT,1/2",NF
4	TF3620A	1	SPRING,TENSIONER
5	27938	1	BUSHING,MACH,1"OD X 1/2"ID X 14GA.
6	40496	1	ROD,THREADED,1/2"NF X 8"
7	PT3611A	1	CLEVIS,6"
8	06504013	1	MOTOR
9	TF3044	1	SHEAVE,8.0"
10	TF3013	1	BUSHING,QD,SK 1-1/4",1/4" KEY
11	TF3040	1	SHEAVE,6.3"
12	28702	2	V-BELT (500)
13	28723	1	BUSHING,QD,SK 1-15/16"
14	32569	1	GUARD,BELT
15	21584	6	CAPSCREW,5/16" X 2",NC
16	21987	6	LOCKWASHER,5/16"
17	06504028	1	KEY (KEY FROM MOTOR)
18	26142A	1	KEY,1/2" X 1/2" X 2"
19	21732	5	CAPSCREW,1/2" X 1-3/4",NC
20	21990	5	LOCKWASHER,1/2"
21	21725	5	HEX NUT,1/2",NC
22	21630	3	CAPSCREW,3/8" X 1",NC
23	22016	2	FLATWASHER,3/8"
24	21988	3	LOCKWASHER,3/8"
25	27580	2	BEARING,DX,1-1/2",GRM
26	28682	1	RETAINING,WASHER,2-1/2" X 5/16"
27	TF4852	2	KIT,FLANGE,#20
28	06500616	1	HOSE,1" X 104" (RETURN FOR STANDARD ROTATION)
30	06500617	1	HOSE,1" X 106" (PRESSURE OF STANDARD ROTATION)
31	6T3204	1	GREASE ZERK,1/4" X 90°
32	6T3211	1	GREASE ZERK,1/8"
33	22085	1	ELBOW,1/8" X 90°
34	TF1032	1	GREASE HOSE

COMMON RSS

# BOOM PIVOT ASSEMBLY

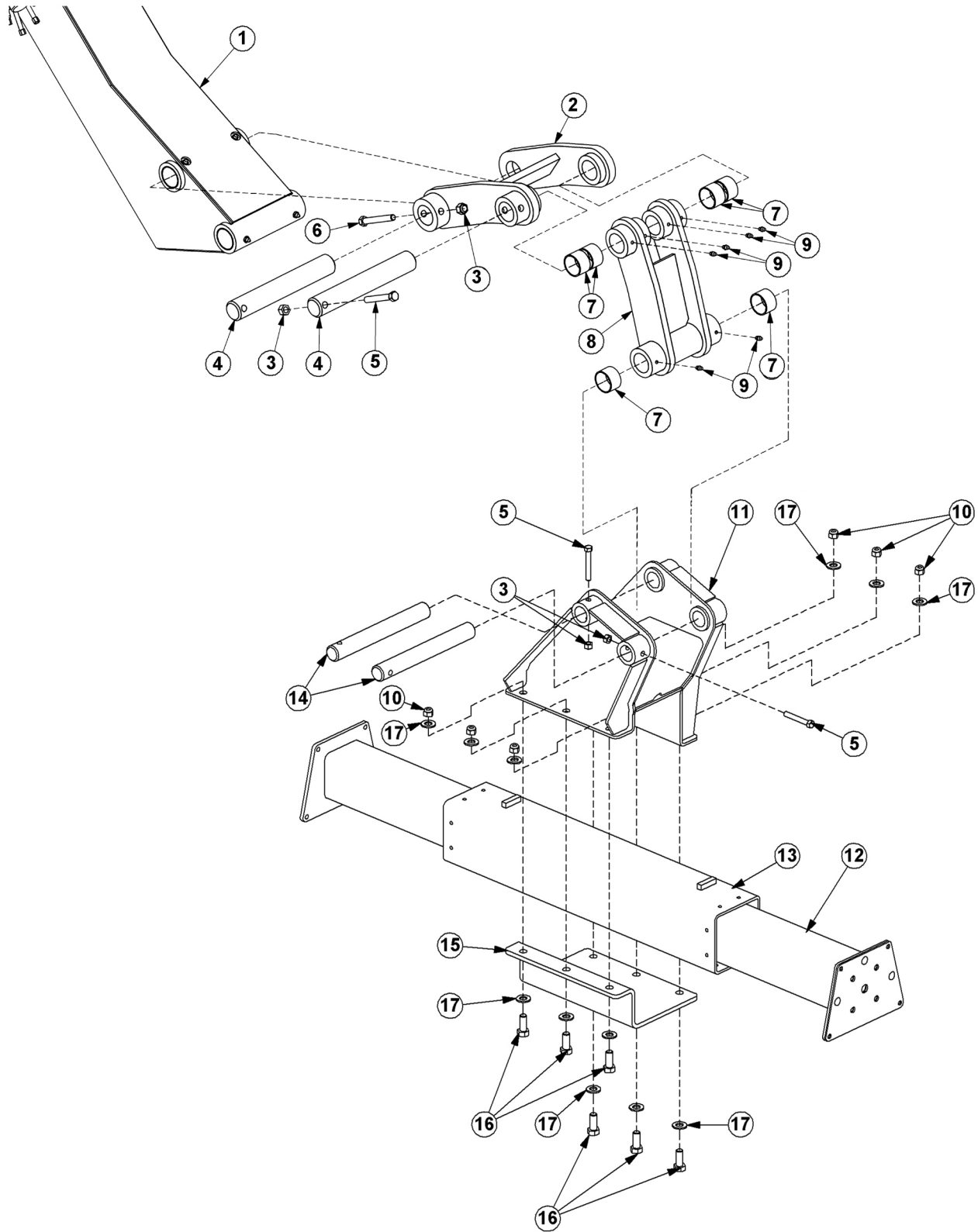

## BOOM PIVOT ASSEMBLY

Continued...

ITEM	PART NO.	QTY.	DESCRIPTION
1	-----	1	BOOM *REFER TO BOOM ASSEMBLY
2	32316	1	LINKAGE, BOOM TO CYLINDER
3	21677	4	NYLOCK NUT, 7/16",NC
4	32319	2	PIN,LINKAGE
5	21687	3	CAPSCREW, 7/16" X 3" NC
6	21688	1	CAPSCREW, 7/16" X 3-1/4" NC
7	32318	6	BEARING
8	32745	1	LINKAGE,CYLINDER TO TREE
9	6T3207	6	GREASE ZERK, 1/4"
10	32838	6	HEX NUT, 5/8" NC
11	06310181	1	TREE, WILDKAT
12	35334	1	TUBE,SLIDE
13	35337	1	TUBE,TREE
14	32313	2	PIN,TREE
15	06412199	1	CLAMP,TREE, WILDKAT
16	06530208	6	CAPSCREW,5/8" X 1-1/2",NC
17	33764	-	FLATWASHER, 5/8" SAE

COMMON RSS

# SLIDE ASSEMBLY

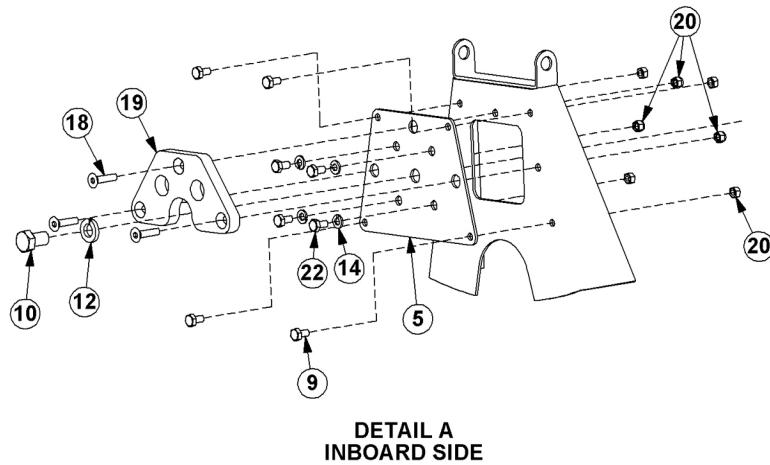
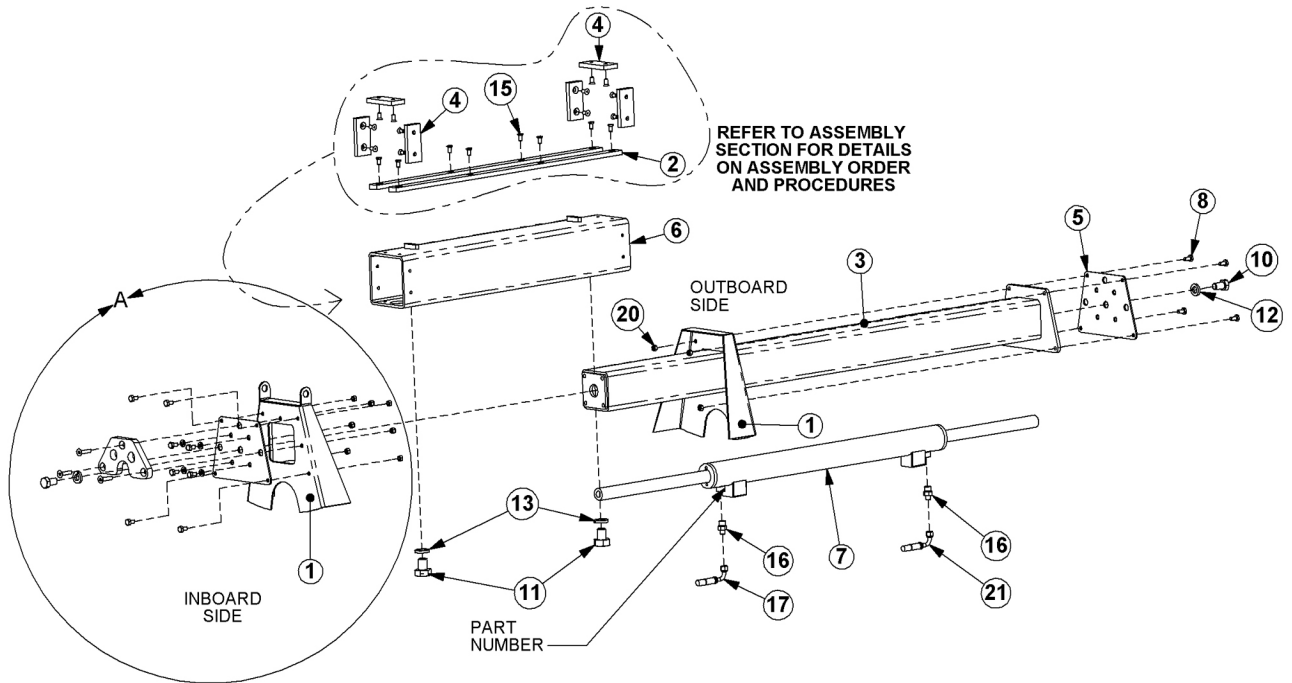



## SLIDE ASSEMBLY

Continued...

ITEM	PART NO.	QTY.	DESCRIPTION
1	-----	-	MOWER *REFER TO MOWER ASSEMBLY PAGE
2	35333	2	PAD,SLIDE
3	35334	1	TUBE,SLIDE
4	35335	6	PAD,SLIDE,SHORT
5	35336	2	CAP
6	35337	1	TUBE,TREE
7	06501027	1	CYLINDER,2-1/2" X 30"
8	21632	4	CAPSCREW,3/8" X 1-1/2",NC
9	21630	4	CAPSCREW,3/8" X 1",NC
10	21804	2	CAPSCREW,3/4" X 1-1/4",NF
11	21929	2	CAPSCREW,1" X 1-1/4",NC
12	21993	2	LOCKWASHER,3/4"
13	21995	2	LOCKWASHER,1"
14	21990	4	LOCKWASHER,1/4"
15	27487	20	CAPSCREW,3/8" X 5/8",NC,FLT/SKT HD
16	33271	2	ADAPTER,1/2"MOR X 3/8"MJ
17	35109	1	HOSE,1/4" X 126" (ROTARY MOWERS)
---	06500449	1	HOSE,1/4" X 53" (FLAIL MOWERS)
18	06530103	3	CAPSCREW,FLT HD,3/8" X 1-1/2",NC
19	06497006	1	BUMPER,RSS
20	21627	11	NYLOCK NUT,3/8",NC
21	06500480	1	HOSE,1/4" X 107" (ROTARY MOWERS)
---	06500449	1	HOSE,1/4" X 53" (FLAIL MOWERS)
22	21729	4	CAPSCREW,1/2" X 1"

COMMON RSS

## HOSE RING ASSEMBLY

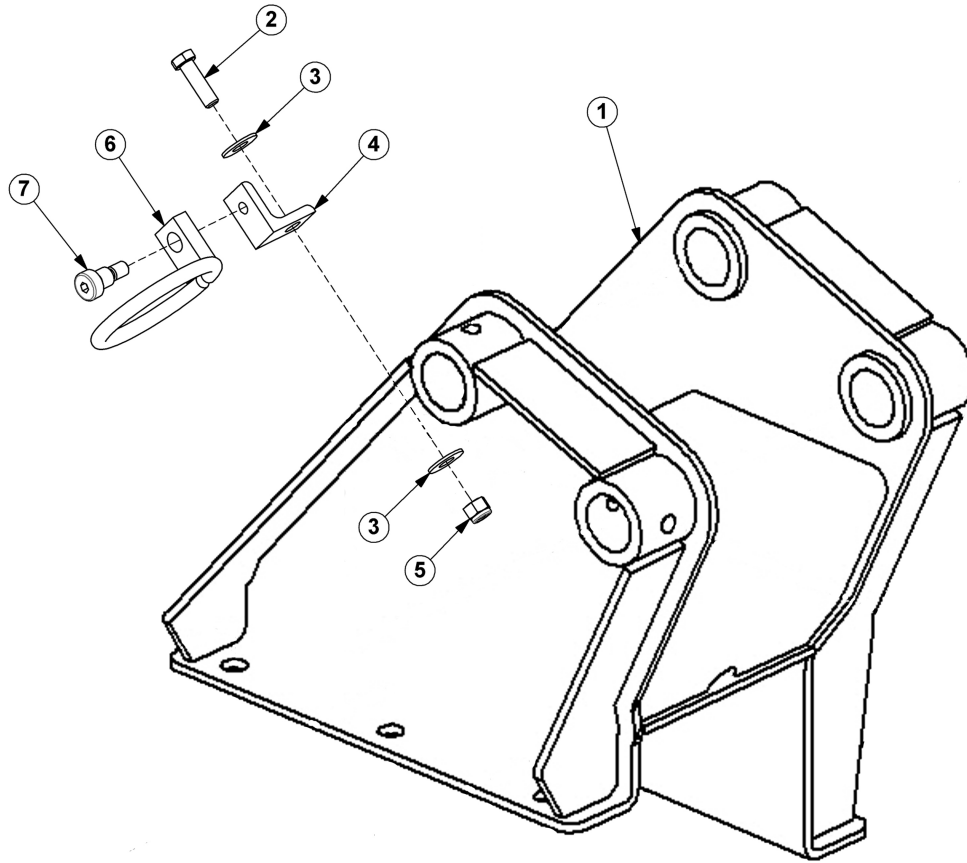

ITEM	PART NO.	QTY.	DESCRIPTION
1	-----	-	TREE *REFER TO BOOM PIVOT ASSY PAGE
2	21631	1	CAPSCREW,3/8" X 1-1/4",NC
3	22016	2	FLATWASHER,3/8"
4	06460043	1	ANGLE,MOUNT
5	21627	1	NYLOCK NUT,3/8",NC
6	6310117	1	RING,HOSE
7	06530003	1	CAPSCREW,SHOULDER,SKT HD
---	06505021	1	COVER,HOSES (BOOM TO HOSE GUIDE) *NOT SHOWN
----	06505020	1	COVER,HOSES (HOSE GUIDE TO DECK) *NOT SHOWN

COMMON RSS

## 2-1/2IN X 30IN CYLINDER BREAKDOWN

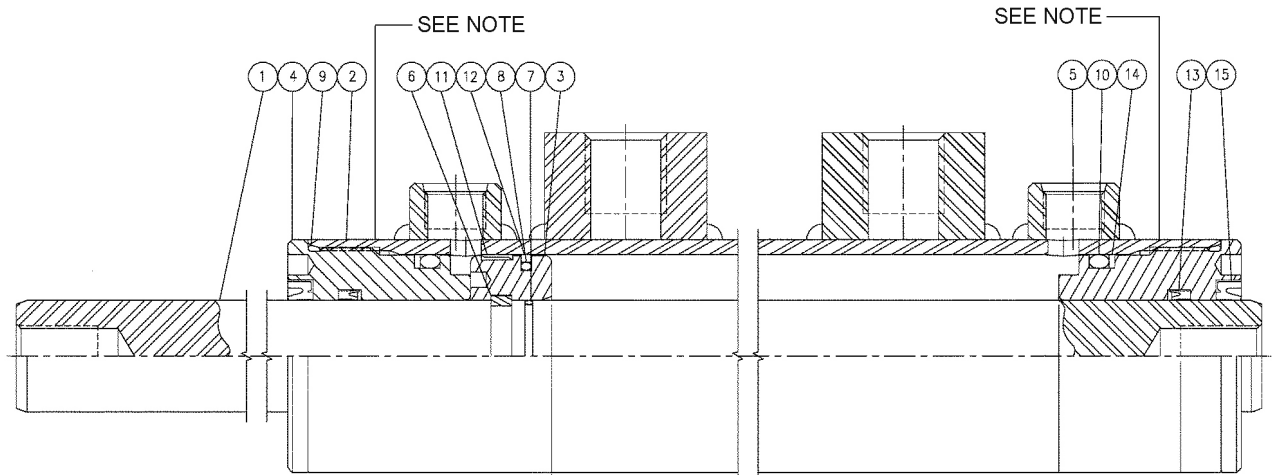

NOTE: BEFORE RE-ASSEMBLY, CLEAN THREADS OF GLAND (ITEM 4)  
AND BUTT/TUBE ASSEMBLY (ITEM 2), AND APPLY (1) DROP OF  
LOCTITE #277 TO THREADS OF GLAND (ITEM 4).

ITEM	PART NO.	QTY.	DESCRIPTION
---	06501027	-	CYLINDER,WELDED,2-1/2" X 30"
1	06501615	1	PISTON ROD ASSY
2	06501616	1	BUTT & TUBE ASSY
3	06501617	1	PISTON
4	06501618	1	GLAND
5	06501598	1	PORT PLUG
6-15	06501619	1	SEAL KIT

COMMON RSS

## 3IN X 15IN CYLINDER BREAKDOWN

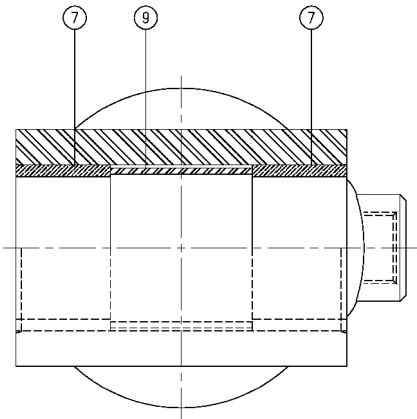
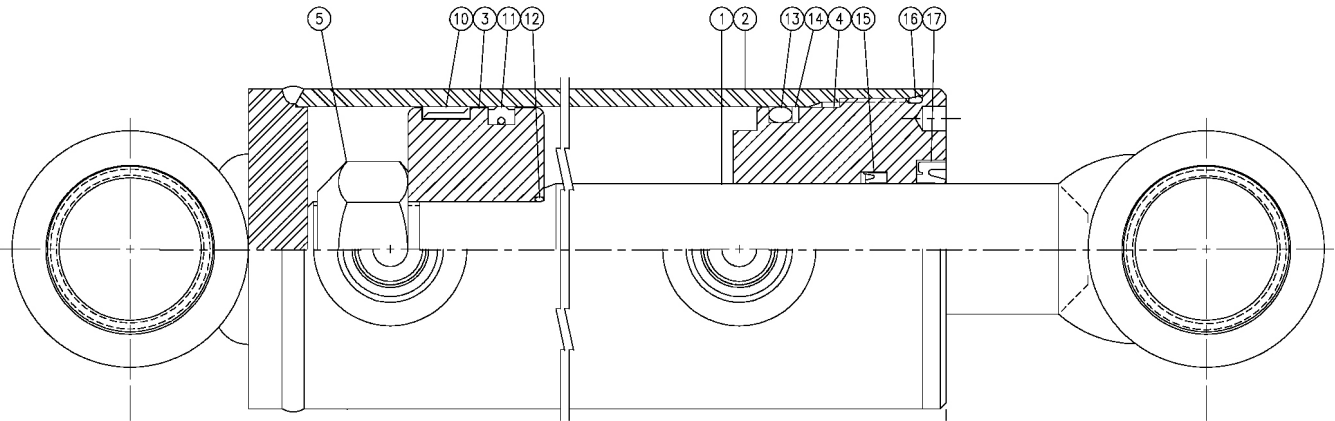

BUTT END VIEW

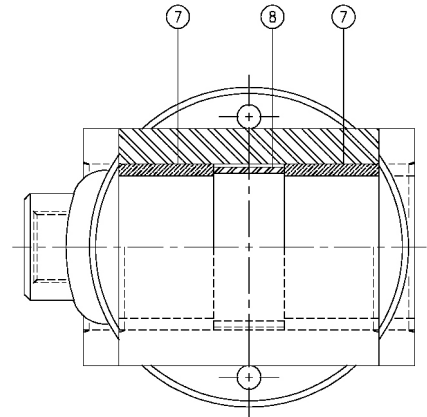

ROD END VIEW

ITEM	PART NO.	QTY.	DESCRIPTION
---	06501026	-	CYLINDER,WELDED,3" X 15"
1	06501608	1	PISTON ROD ASSY
2	06501609	1	BUTT & TUBE ASSY
3	06501610	1	PISTON
4	06501563	1	GLAND
5	6T0179	1	LOCK NUT,1-1/4"-12 UNF (TORQUE TO 315 FT.LB.)
6	06501598	2	PORT PLUG (NOT SHOWN)
7	06501611	4	BUSHING
8	06501612	1	SPACER,ROD END
9	06501613	1	SPACER,BUTT END
10-17	06501614	1	SEAL KIT

COMMON RSS

## 4IN X 14IN CYLINDER BREAKDOWN

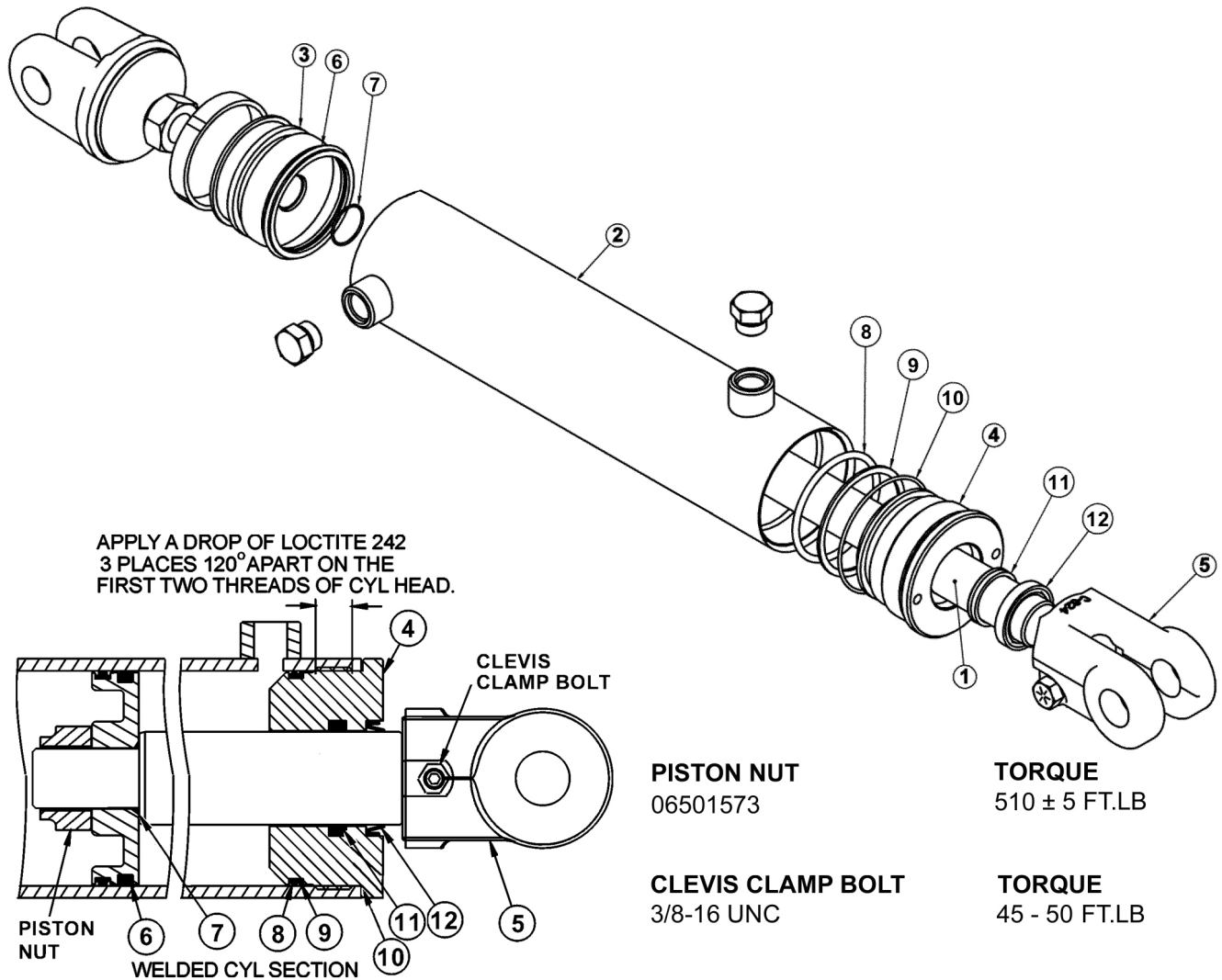

**WARNING - MECHANICAL FASTENERS MUST BE TORQUED TO RECOMMENDED SPECIFICATIONS DURING REPAIR TO PREVENT PERSONAL INJURY OR EQUIPMENT DAMAGE.**

ITEM	PART NO.	QTY.	DESCRIPTION
-----	06501028	1	HYDRAULIC CYLINDER COMPLETE
1	06501623	1	ROD
2	06501624	1	TUBE WELDMENT
3	06501558	1	PISTON
4	06501607	1	CYLINDER HEAD
5	6T0172	1	CLEVIS
-----	06501560	1	SEAL REPAIR KIT (ITEMS 6 THROUGH 12)

## 4IN X 15IN CYLINDER BREAKDOWN

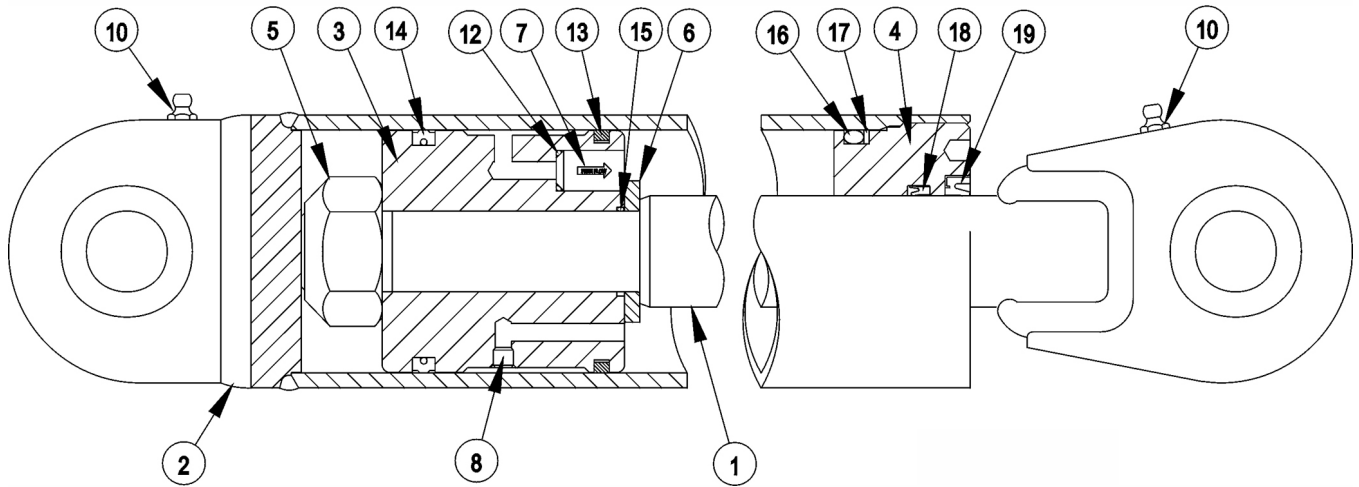

**WARNING** - MECHANICAL FASTENERS MUST BE TORQUED TO RECOMMENDED SPECIFICATIONS DURING REPAIR TO PREVENT PERSONAL INJURY OR EQUIPMENT DAMAGE.

ITEM	PART NO.	QTY.	DESCRIPTION
---	32365	-	CYLINDER,WELDED,4" X 15"
1	06501604	1	PISTON ROD ASSY
2	06501605	1	BUTT & TUBE ASSY
3	06501606	1	PISTON
4	06501607	1	GLAND
5	06501753	1	LOCK NUT,1-1/4"-12 UNF (TORQUE TO 510 FT.LB.)
9	33757	1	SEAL KIT,PACKING (ITEMS 12 THRU 19)
10	-----	2	GREASE ZERK
12	-----	1	O - RING
13	-----	1	CAST IRON PISTON RING
14	-----	1	CROWN SEAL
15	-----	1	O - RING
16	-----	1	O - RING
17	-----	1	BACK - UP WASHER
18	-----	1	U - CUP
19	-----	1	WIPER
20	34335	2	SPHERICAL BEARING (NOT SHOWN)

# NOTES

# 5 SPOOL ELECTRONIC VALVE

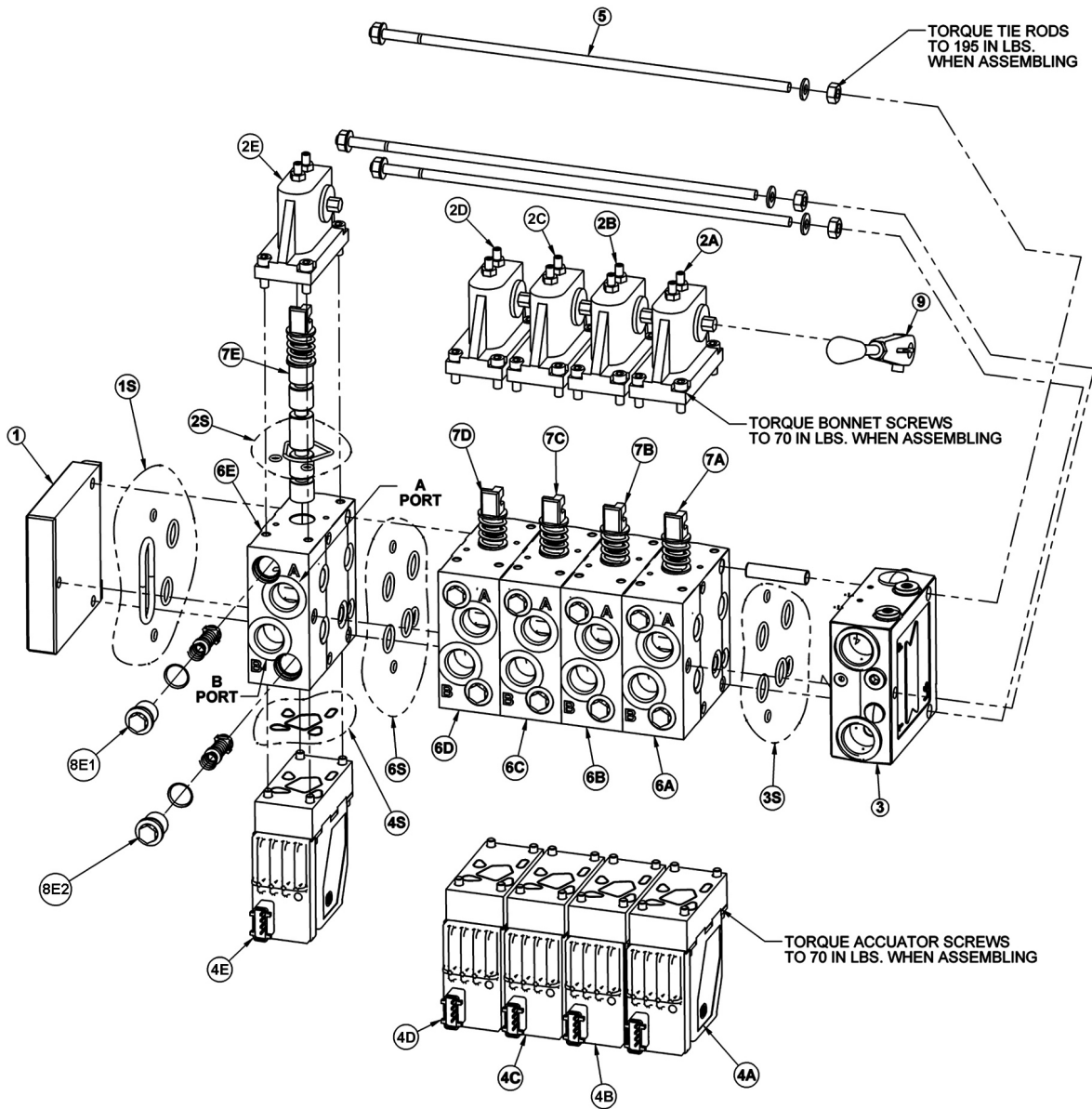

ITEM	PART NO.	QTY.	DESCRIPTION
-----	06502096	-	VLV,5SP,32PVG,SIDE STOW
1	06502074	1	END PLATE
1S	06505013	1	END PLATE SEAL KIT
2	-----	5	BONNET
2S	06505042	1	BONNET SEAL KIT
2A	42197	1	MAIN BOOM BONNET
2B	42197	1	SECONDARY BOOM BONNET
2C	42197	1	DECK ROLL BONNET
2D	42197	1	BOOM SWIVEL BONNET
2E	42197	1	DECK SHIELD BONNET

COMMON RSS



## 5 SPOOL ELECTRONIC VALVE

Continued...

ITEM	PART NO.	QTY.	DESCRIPTION
3	34308	1	INLET SECTION
3S	06505013	1	INLET SECTION SEAL KIT
4	-----	5	ELECTRONIC ACCUATOR
4A	06502101	1	MAIN BOOM ELECTRONIC ACCUATOR
4B	06502101	1	SECONDARY BOOM ELECTRONIC ACCUATOR
4C	06502100	1	DECK ROLL ELECTRONIC ACCUATOR
4D	06502101	1	BOOM SWIVEL ELECTRONIC ACCUATOR
4E	06502099	1	DECK SHIELD ELECTRONIC ACCUATOR
5	42202	1	TIE-BOLT KIT
6	-----	5	SECTION
6S	06505013	1	SECTION SEAL KIT
6A	42698	1	MAIN BOOM SECTION
6B	42698	1	SEC BOOM SECTION
6C	06502076	1	DECK ROLL SECTION
6D	42698	1	BOOM SWIVEL SECTION
6E	06502077	1	SHIELD SECTION
7	-----	5	SPOOL
7A	42697	1	MAIN BOOM SPOOL
7B	42697	1	SEC BOOM SPOOL
7C	4242106	1	DECK ROLL SPOOL
7D	06502073	1	BOOM SWIVEL SPOOL
7E	42201	1	DECK SHIELD SPOOL
8	-----	10	ANTI CAV/SHOCK RELIEF
8A1	42650	1	MAIN BOOM A PORT RELIEF
8A2	06502069	1	MAIN BOOM B PORT RELIEF
8B1	42650	1	SEC BOOM A PORT RELIEF
8B2	42295	1	SEC BOOM B PORT RELIEF
8C1	42296	1	DECK ROLL A PORT RELIEF
8C2	42295	1	DECK ROLL B PORT RELIEF
8D1	42295	1	BOOM SWIVEL A PORT RELIEF
8D2	42295	1	BOOM SWIVEL B PORT RELIEF
8E1	06502069	1	DECK SHIELD A PORT RELIEF
8E2	06502069	1	DECK SHIELD B PORT RELIEF
9	33459	1	HANDLE

COMMON RSS

# FRONT PUMP BREAKDOWN

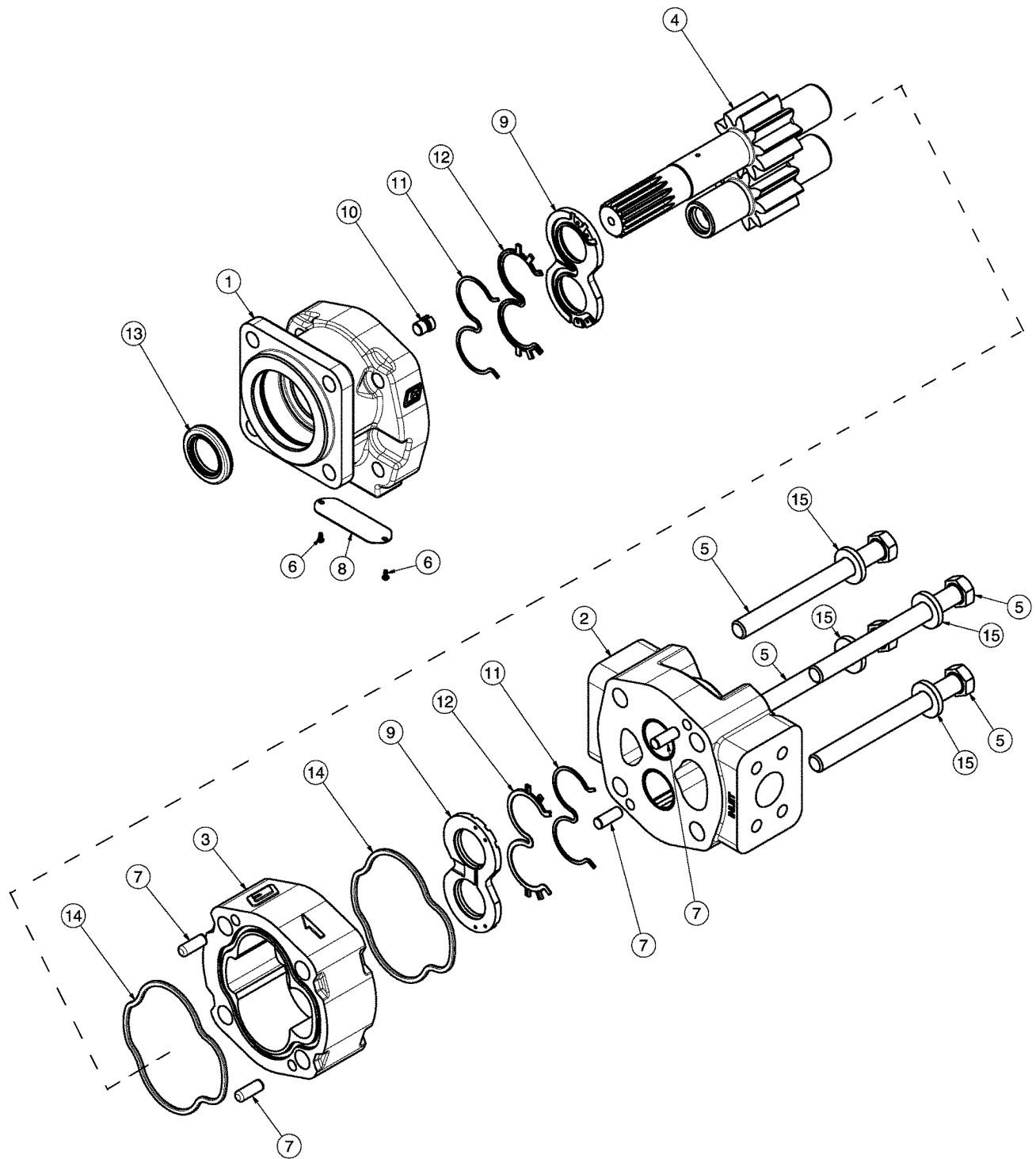

COMMON RSS

## FRONT PUMP BREAKDOWN

Continued...

ITEM	PART NO.	QTY.	DESCRIPTION
---	23152	1	PUMP ASSEMBLY,1-3/4",COMPLETE
1	22766	1	SHAFT END COVER
2	22779	1	PORT END COVER
3	22774	1	GEAR HOUSING,1-3/4"
4	22771	1	GEAR SET
5	23824	4	CAPSCREW
6	06504078	2	SCREW,DRIVE
7	22773	4	DOWEL PINS
8	06504077	1	NAMEPLATE
9	22770	2	THRUST PLATE
10	22767	1	PLUG
11	06504075	2	SEAL,BK-UP
12	06504074	2	SEAL,CHAN
13	22765	1	SEAL,LIP
14	06504076	2	SEAL,SQ-R
15	02961917	4	WASHER
---	24150	1	SEAL KIT (INCLUDES 11, 12, 13 AND 14)

COMMON RSS

# ROTARY MOTOR BREAKDOWN

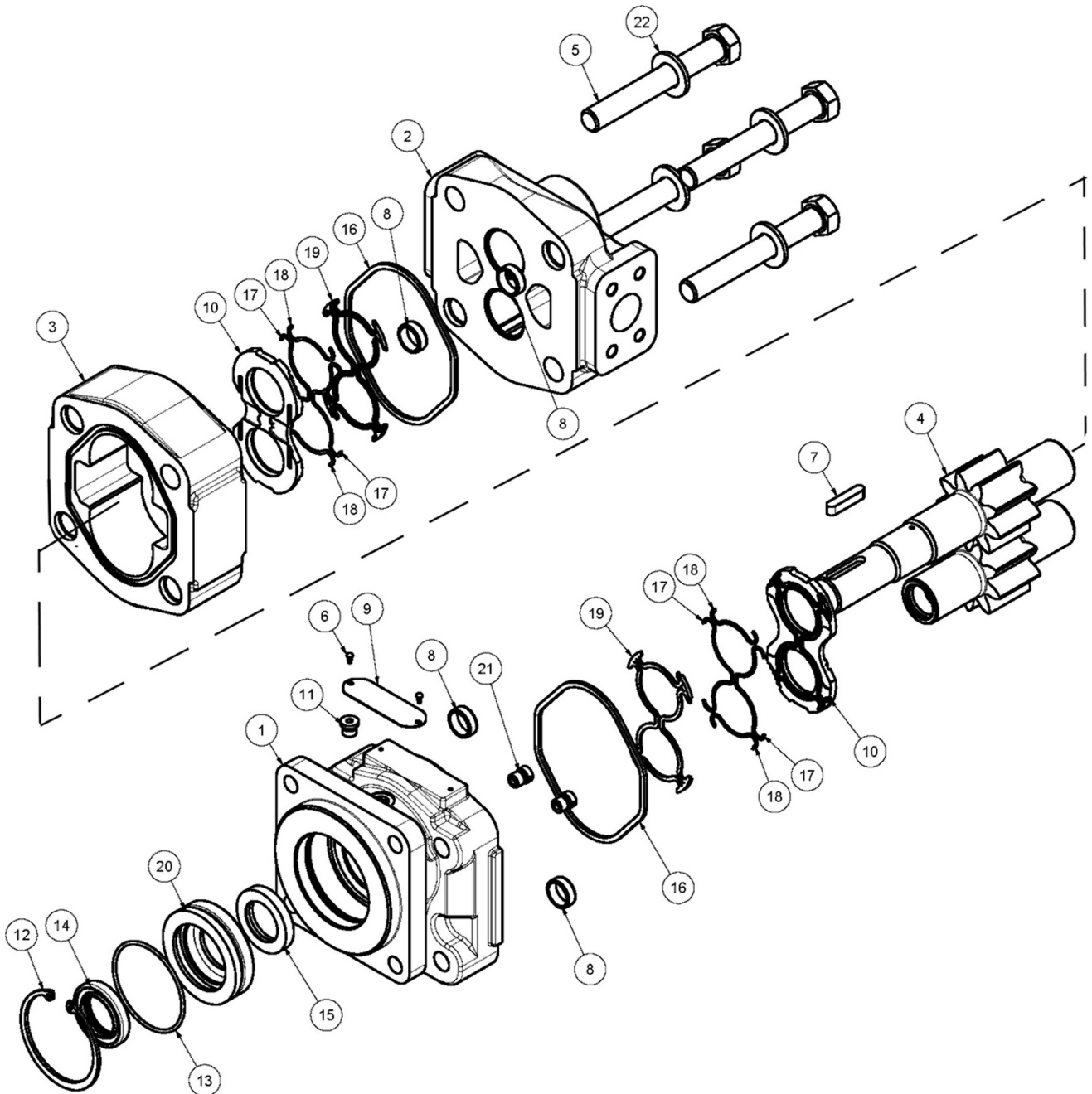

COMMON RSS

## ROTARY MOTOR BREAKDOWN

Continued...

ITEM	PART NO.	QTY.	DESCRIPTION
---	06504011	-	MOTOR ASSEMBLY,TRB60
1	22790	1	END,COVER
2	06504088	1	HOUSING, PEC
3	06504062	1	HOUSING, GEAR,TRB60
4	06504090	1	SET, GEAR SHAFT
5	06504104	4	CAP SCREW,TRB60
6	06504078	2	SCREW, DRIVE
7	06504092	1	KEY
8	06504093	4	PIN, DOWEL
9	06504094	1	NAME PLATE
10	06504095	2	THRPL
11	2961940	1	PLUG, ODT
12	2962200	1	RING, SNAP
13	06504096	1	O RING
14	6T5101	1	SEAL, LIP
15	06504097	1	SEAL, LIP
16	22797	2	SEAL, SQ-R
17	06504098	4	SEAL, SIDE CHAN
18	06504099	4	SEAL, END CHAN
19	06504100	2	SEAL, BK-UP
20	06504101	1	RTNR, SEAL
21	6T5809	2	CHECK ASS'Y
22	06504102	4	WASHER
---	06504103	1	SEAL KIT

COMMON RSS

# FLAIL MOTOR BREAKDOWN

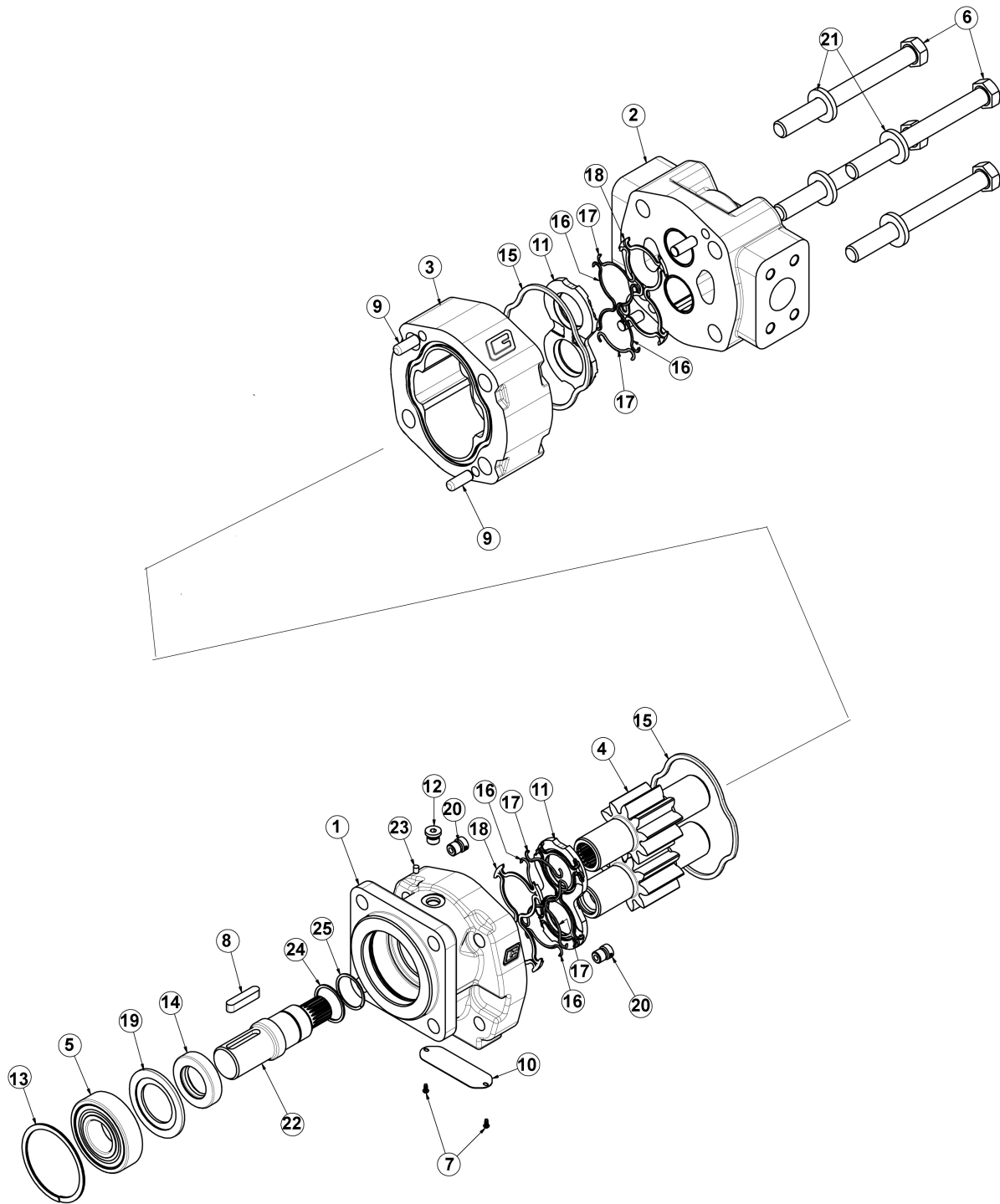

COMMON RSS

## FLAIL MOTOR BREAKDOWN

Continued...

ITEM	PART NO.	QTY.	DESCRIPTION
---	06504132	1	MOTOR ASSEMBLY 350 - TBF50, TBF63
1	06504141	1	SHAFT END COVER
2	06504040	1	PORT END COVER
3	06504041	1	GEAR HOUSING
4	06504117	1	MATCHED GEAR SET
5	TF4402	1	BALL BEARING
6	06504043	4	CAP SCREW
7	06504044	2	SET SCREW
8	06504028	1	KEY
9	06504045	4	DOWEL PIN
10	-----	1	NAMEPLATE
11	0763759	1	THRUSTPLATE
12	02961940	1	PLUG, ODT (0.25)
13	TF4401	1	SNAP RING
14	06504142	1	LIP SEAL
15	TF4410	2	GASKET SEAL
16	06504046	4	SIDE SEAL
17	06504047	4	END SEAL
18	TF4407	2	BACK-UP SEAL
19	06504122	1	SEAL RETAINER
20	6T5809	2	CHECK ASSEMBLY
21	02961917	4	WASHER
22	06504140	1	SHAFT
23	06504139	1	BREATHER
24	06504121	1	SPACER, BRG
25	06504119	1	SNAP RING
---	06504022	1	SEAL KIT

COMMON RSS

# COOLER ASSEMBLY - OPTION

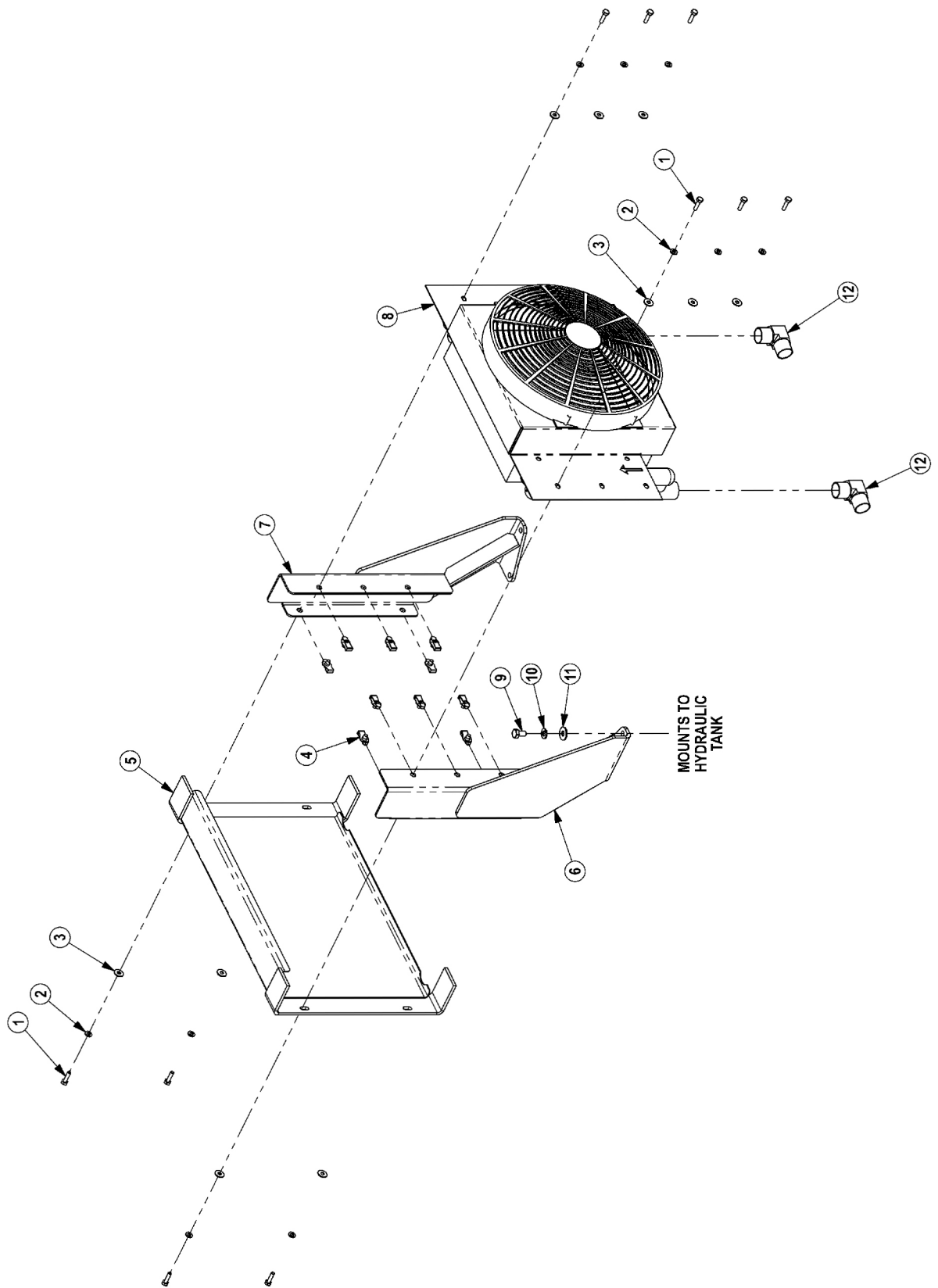

COMMON RSS



## COOLER ASSEMBLY - OPTION

Continued...

ITEM	PART NO.	QTY.	DESCRIPTION
1	21530	10	CAPSCREW,1/4 X1 NC
2	21986	10	LOCKWASHER,1/4
3	22014	10	FLATWASHER,1/4
4	35176	10	1/4 U-NUT
5	06370015	1	SCREEN,COOLER,FRNT
6	06380006	1	MNT,COOLER,BUMPER TANK,RH
7	06380007	1	MNT,COOLER,BUMPER TANK,LH
8	06510026	1	COOLER,FRONT MNT
---	06510029	1	FAN ASSY, ONLY
9	21629	4	CAPSCREW,3/8 X 3/4 NC
10	21988	4	LOCKWASHER,3/8
11	22016	4	FLATWASHER,3/8
12	34117	2	ELBOW,1MOR X 1MJ90,FORGED

COMMON RSS

## RESERVOIR TANK FILTER ASSEMBLY

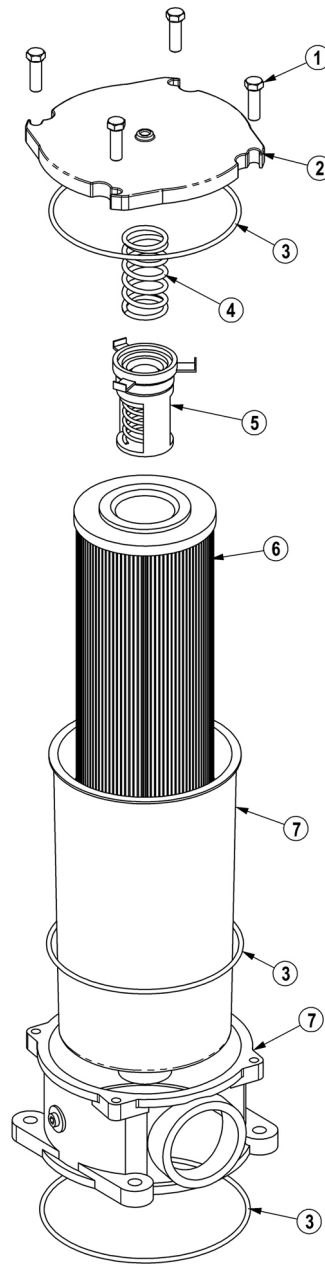

ITEM	PART NO.	QTY.	DESCRIPTION
---	06505044	-	FILTER ASSY SAE 10 MICRON
1	28583	4	CAPSCREW,8MM X 25MM(1.25 PITCH)
2	06505045	1	COVER
3	06505046	1	SEAL KIT
4	06505047	1	SPRING
5	06505048	1	BYPASS
6	35259	1	FILTER,10 MIC,RETURN LINE
7	06505049	1	CAN/BODY

COMMON RSS

## PUMP AND GRILL GUARD OPTIONS

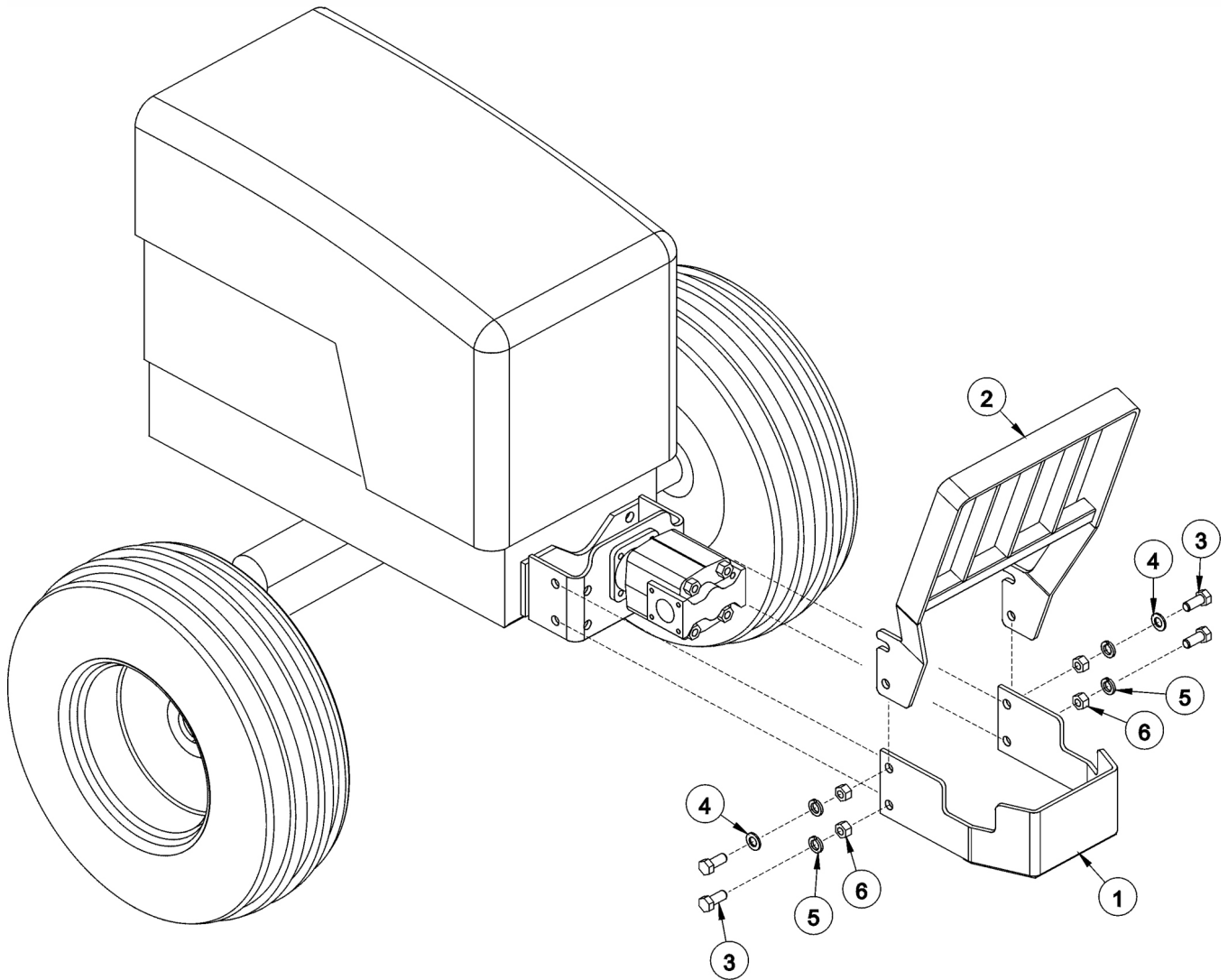

ITEM	PART NO.	QTY.	DESCRIPTION
1	32430	1	UNIVERSAL PUMP GUARD
2	32737	1	UNIVERSAL GRILL GUARD
3	21833	4	CAPSCREW,3/4" X 2-1/4",NC
4	22021	2	FLATWASHER,3/4"
5	21993	4	LOCKWASHER,3/4"
6	21825	4	HEX NUT,3/4",NC

COMMON RSS

## MANUAL LIFT VALVE SWITCH BOX

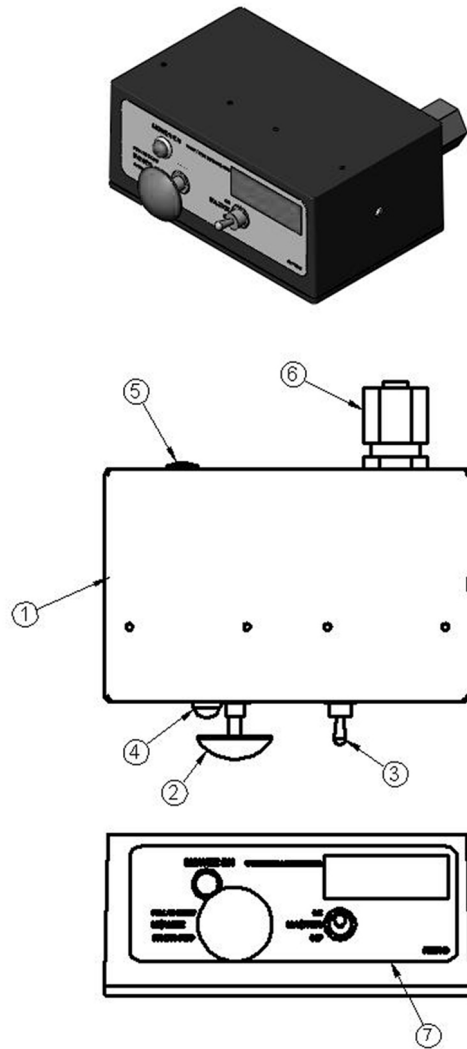

ITEM	PART NO.	QTY.	DESCRIPTION
1	06514013	1	SWBX,ALUM,BLK,06510102
2	35226	1	SWITCH,MOWER,COLEHERSEE
3	33811	1	SWITCH,MASTER/DECK FLOAT
4	6T3923	1	INDICTATOR LIGHT,ON,RED
5	06514014	1	BREAKER,10A,SWBX
6	34540	1	STRAIN RELIEF,3/4,BLACK,NYLON
7	06550018	1	DECAL,SWTCHBX,TM/TSF,CG
8	35227	1	RELAY,DP,DT,12V,LY2F,35226

COMMON RSS

MANUAL LIFT VALVE SWITCH BOX SCHEMATIC

06510102 SCHEMATIC  
COMMON GROUND SWITCH BOX  
SIDE MOWER

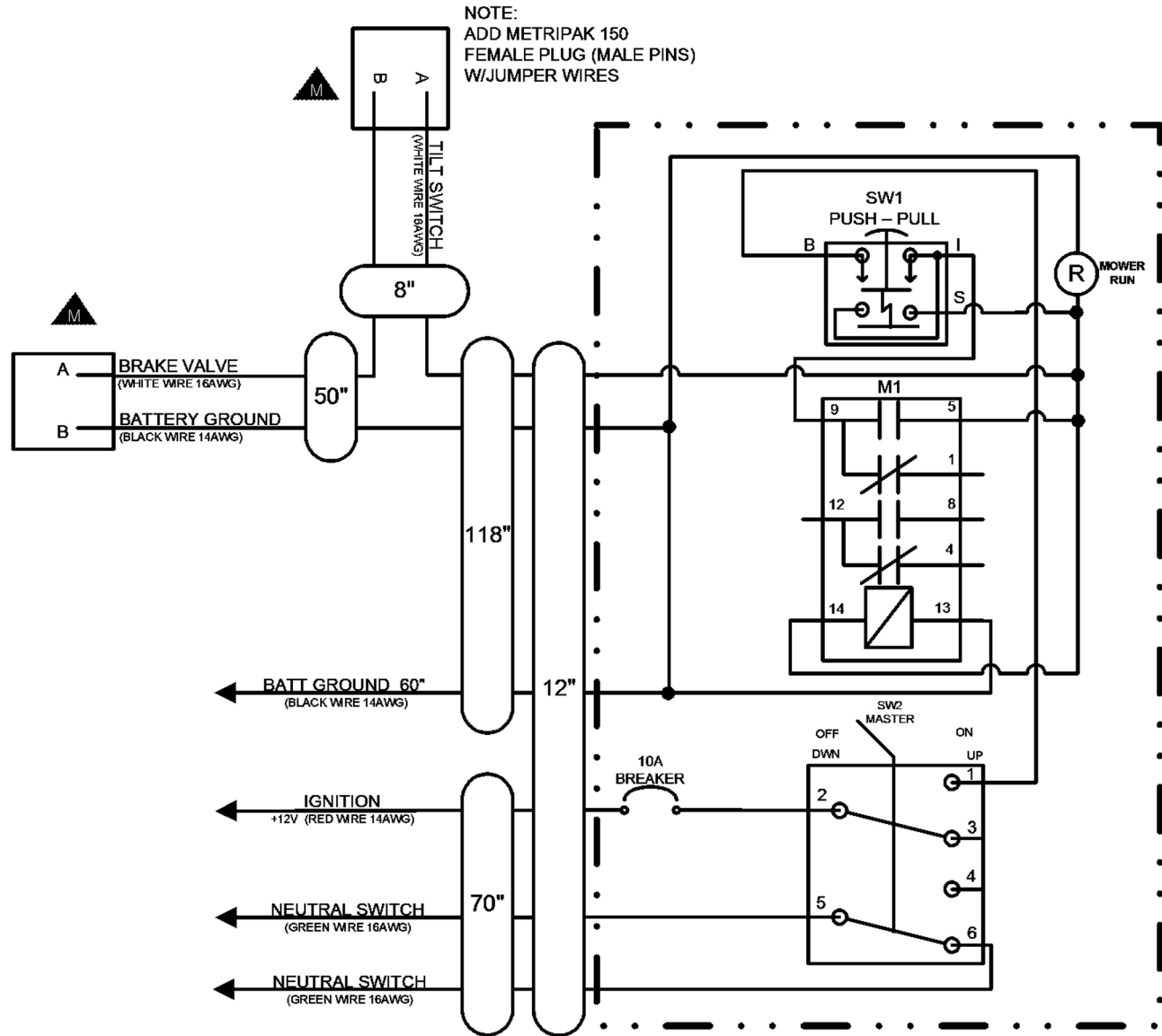

SEE DRAWING # 06515000 FOR A FULL DESCRIPTION OF ALL CONNECTORS

## ELECTRONIC LIFT VALVE SWITCH BOX

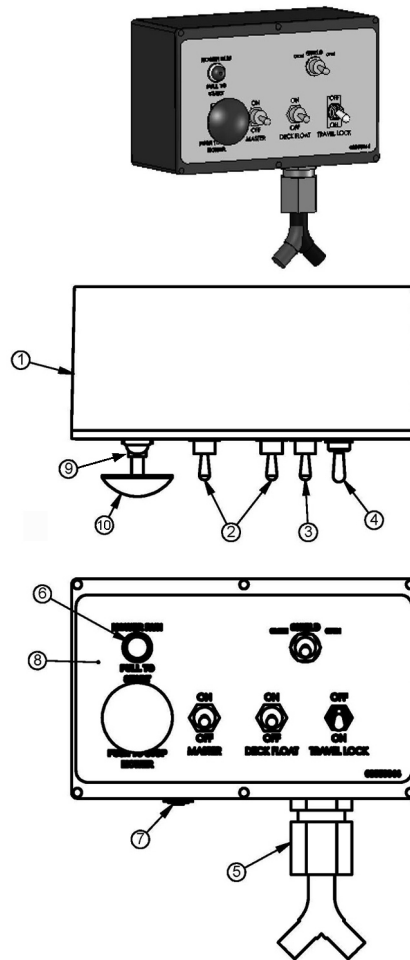

ITEM	PART NO.	QTY.	DESCRIPTION
1	06510196	1	SWBX,ASSY
2	33811	2	SWITCH,MASTER/DECK FLOAT
3	33813	1	SWITCH,SFTY SHIELD
4	34532	1	SWITCH,TRVL LCK
5	34540	1	STRAIN RELIEF,3/4",BLACK,NYLON
6	6T3923	1	INDICTATOR LIGHT,ON,RED
7	06514006	1	BREAKER,15A,SWBX
8	06550044	1	DECAL,SWBX,06510047
9	35226	1	SWITCH,MOWER,COLEHERSEE
10	35227	1	RELAY,DP,DT,12V,LY2F,35226

COMMON RSS

# ELECTRONIC LIFT VALVE SCHEMATIC

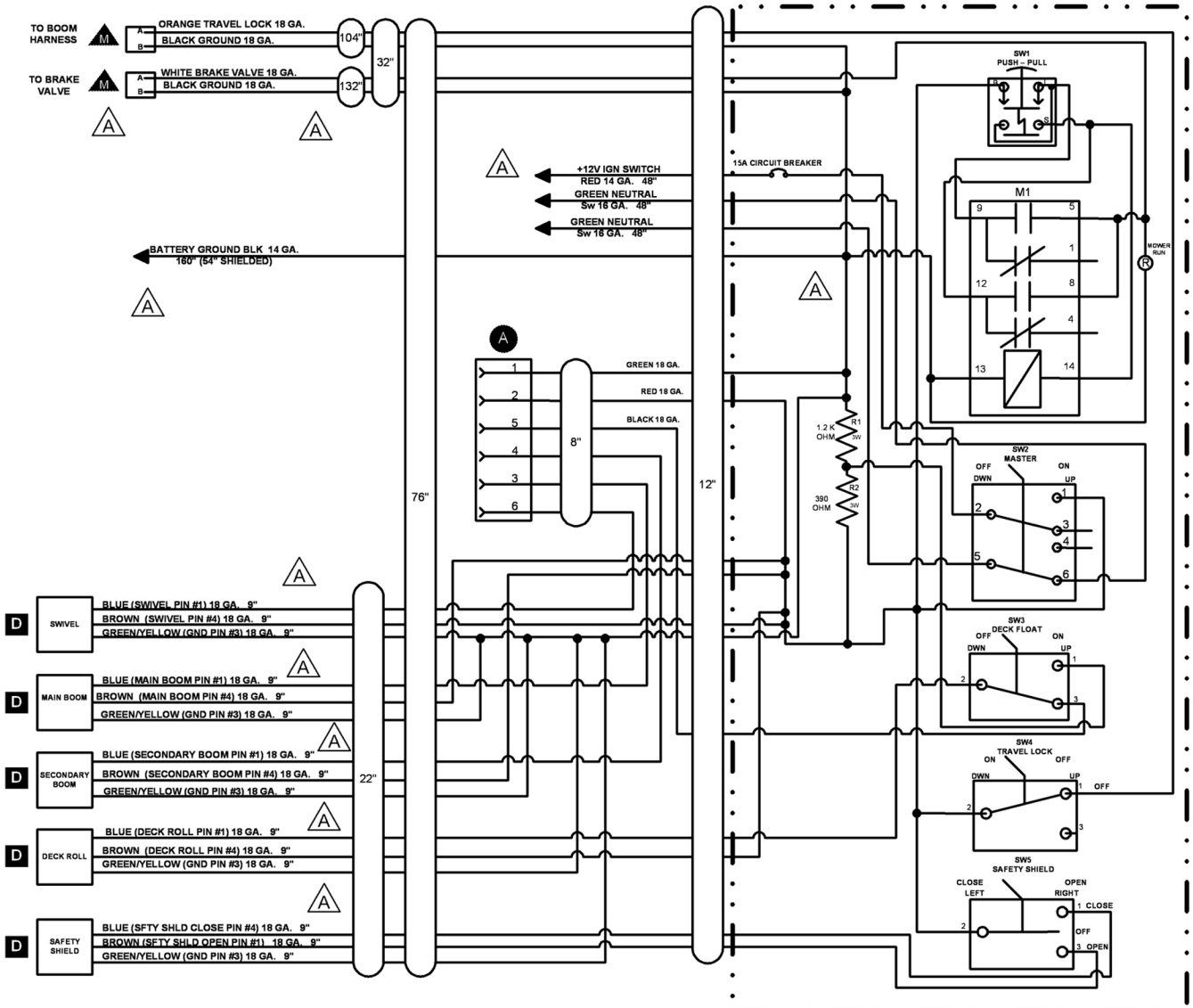

COMMON RSS

## SOLENOID SWITCH BOX AND WIRING

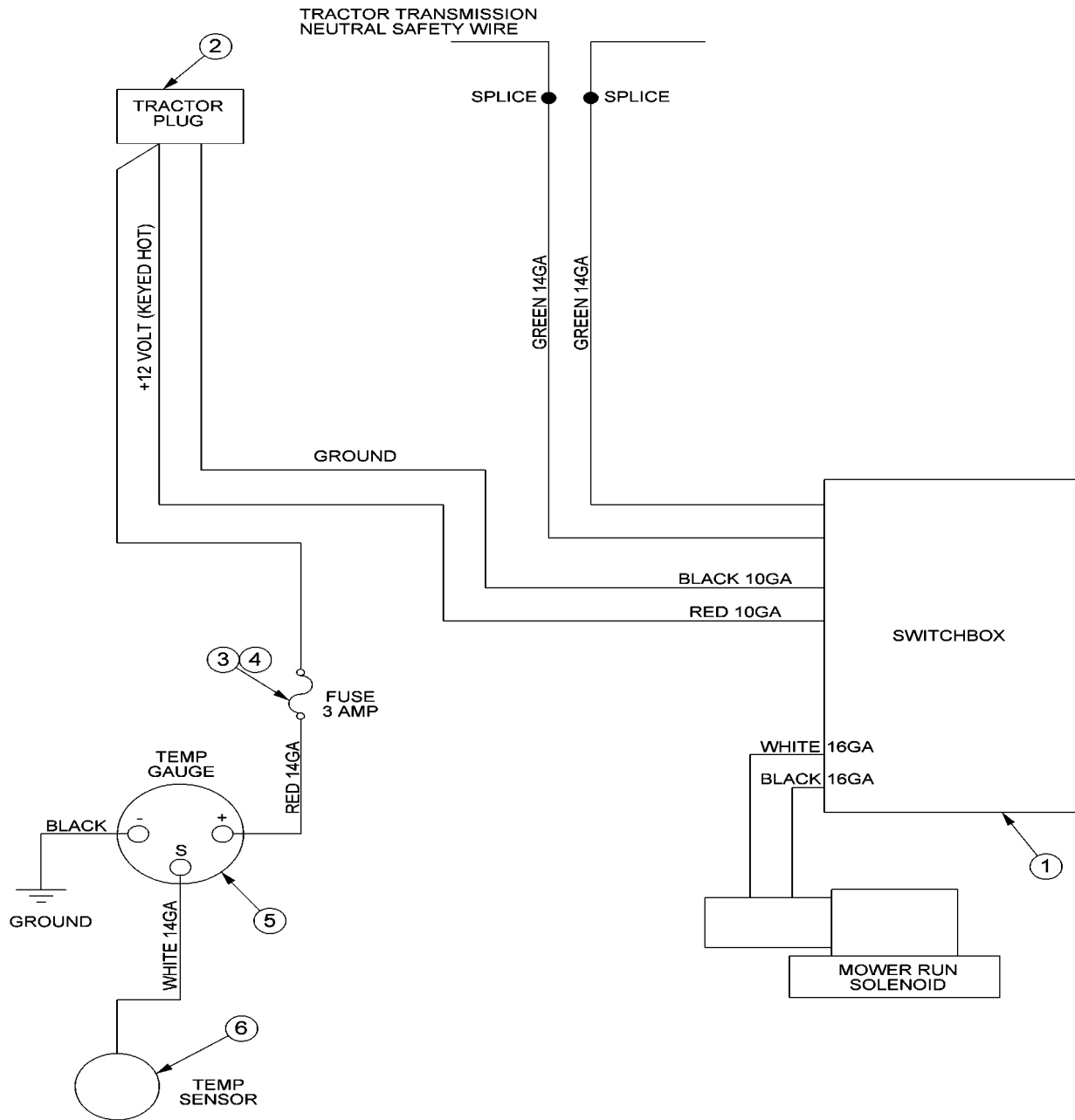

ITEM	PART NO.	QTY.	DESCRIPTION
1	-----	-	SWITCH BOX
2	RE37651	1	PLUG,AUX PWR
3	24204	1	FUSE HOLDER,IN-LINE (OPTION)
4	6T3965	1	FUSE,3AMP (OPTION)
5	6T3934	1	TEMPERATURE GAUGE (OPTION)
6	6T3931	1	TEMPERATURE SENSOR (OPTION)

COMMON RSS



## BRAKE VALVE ASSEMBLY

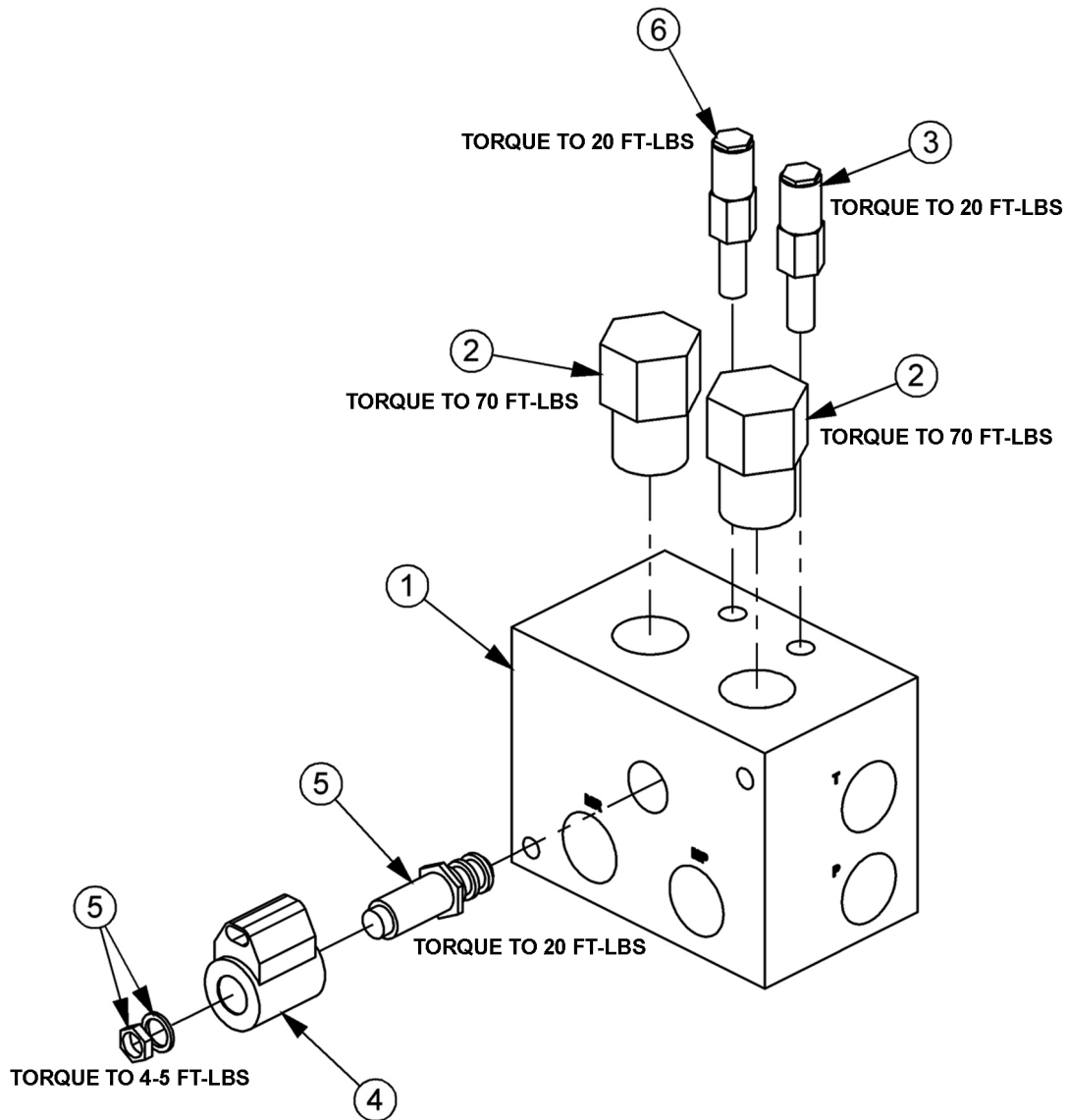

ITEM	PART NO.	QTY.	DESCRIPTION
---	06510083	1	BRAKE VALVE, ASSY
1	34092	1	BRAKE VALVE, BLANK
2	34094	2	LOGIC ELEMENT
3	34095	1	RELIEF VALVE, 3000 PSI
4	06510095	1	METRI PAK COIL
5	34093	1	CARTRIDGE, 2 POSITION, 3 WAY (WITH NUT & WASHER)
6	34091	1	RELIEF VALVE, 2600 PSI
---	34096	2	RELIEF SEAL KIT
----	34097	1	SOLENOID SEAL KIT
---	34098	2	ELEMENT SEAL KIT

COMMON RSS

## BRAKE VALVE HYDRAULIC SCHEMATIC

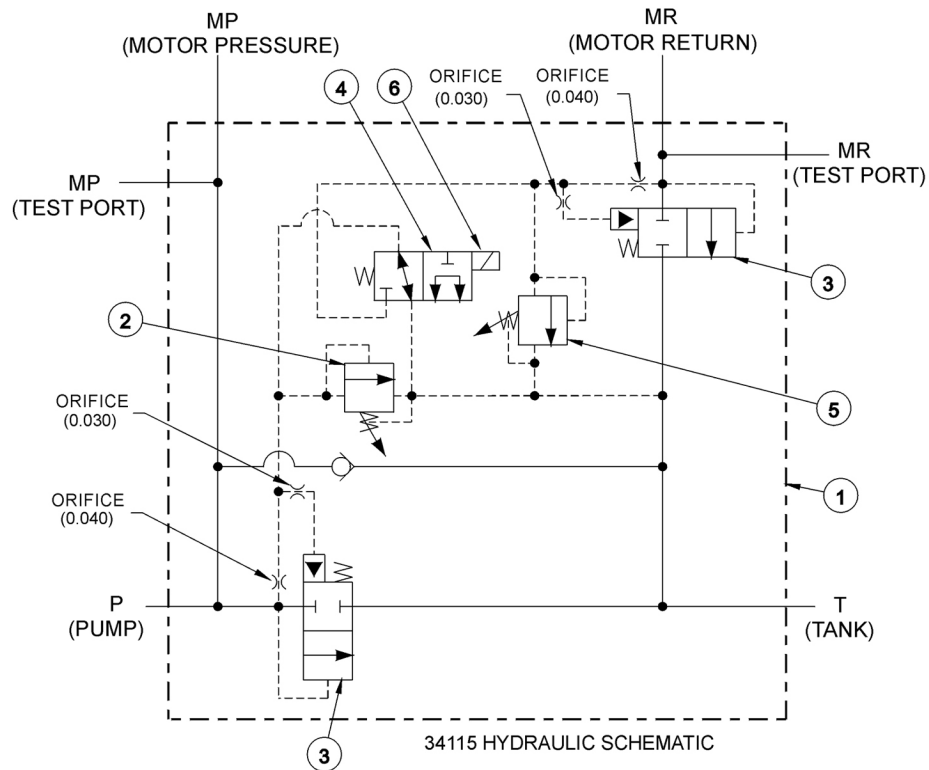

### BRAKE VALVE TROUBLESHOOTING

#### FAILURE MODE:

- MOWER WILL NOT START - system pressure is low (engine not lugging).
- MOWER WILL NOT START - system pressure is high (engine lugging). "MR" port will be high pressure.
- MOWER WILL NOT ROTATE AT FULL SPEED - limited power.
- MOWER BLADE WILL NOT STOP - blade will not stop in proper time.

#### CHECK STEPS

- 1 thru 6
- 7
- 3 thru 5
- 7 thru 9

#### CORRECTIVE STEPS:

1. Check for voltage at solenoid (item 6), voltage must be between 10.2 volts and 13.8 volts.
2. Remove, inspect solenoid and cartridge (items 4, 6) for wear or contamination.
3. Remove, inspect logic elements near "P" port (item 3) for wear or contamination.
4. Remove, inspect 3000 psi relief valve (item 2) for wear or contamination.
5. Remove and inspect orifices near "P" port for contamination.
6. Remove "P" port hose and fitting, visually inspect for contamination, check ball for movement.
7. Remove and inspect orifices near "MR" port for contamination.
8. Remove, inspect 2600 psi relief valve (item 5) for wear of contamination.
9. Remove, inspect logic element near "MR" port (item 3) for wear or contamination.

# ELECTRICAL TROUBLESHOOTING GUIDE

## Joystick Electrical Troubleshooting guide

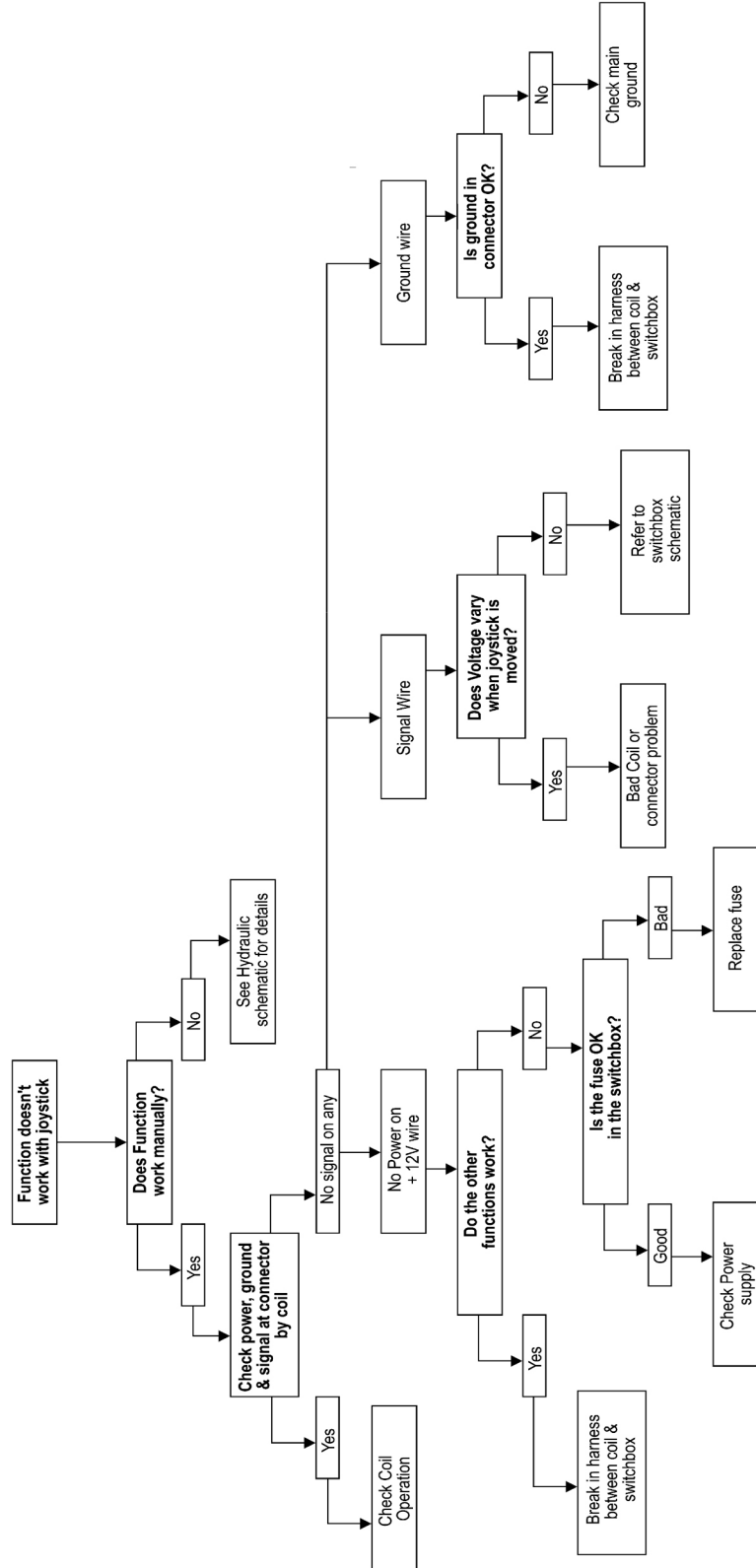

# HYDRAULIC TROUBLESHOOTING GUIDE

## Hydraulic Troubleshooting guide

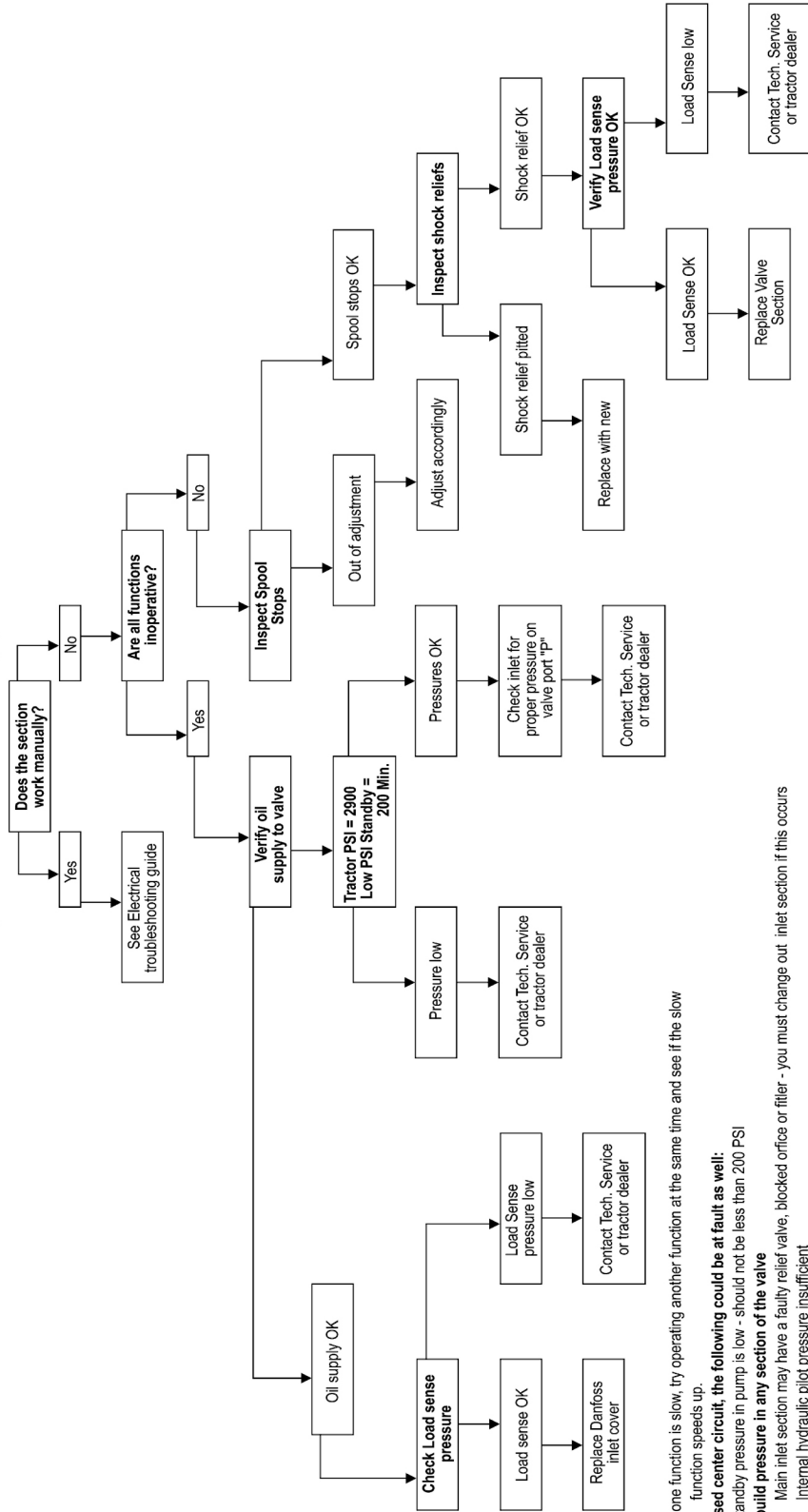

**Notes:** If one function is slow, try operating another function at the same time and see if the slow function speeds up.

**On a closed center circuit, the following could be at fault as well:**

Tractor standby pressure in pump is low - should not be less than 200 PSI

**Cannot build pressure in any section of the valve**

Main inlet section may have a faulty relief valve, blocked orifice or filter - you must change out inlet section if this occurs  
Internal hydraulic pilot pressure insufficient

## TROUBLESHOOTING

### JOYSTICK TROUBLESHOOTING

Boom operation not responding to joystick movement.  
Isolate hydraulic vs. electronic symptom.

Turn off electronic master switch (preventing electronic actuator on valve from attempting to hold spool in neutral position). With tractor engine running, operate the valve section with the manual handle. If function operates normally, continue with electronic inspection. If function does not operate normally, continue with hydraulic inspection.

Electronic inspection.

Connect a voltmeter to the cable connector of the valve section that is not operating. This will allow you to measure supply and signal voltage when the joystick is operated.

Main, Secondary, and Swivel Valves – signal voltage should be 50% of supply voltage with joystick in Neutral position, up to 75% of supply voltage in B direction, down to 25% of supply voltage in A direction. Signal voltage should change smoothly with lever movement.

Pin #1 – Supply Voltage  
Pin #2 – Signal Voltage  
Pin #gnd – ground

Deck Roll Valve or Float Valve – signal voltage should be 50% of supply voltage with joystick in Neutral position, up to 65% of supply voltage in B direction, down to 35% of supply voltage in A direction. Signal voltage should change smoothly with lever movement. Signal voltage should be approximately 75% of supply voltage when float switch is operated.

Pin #1 – Supply Voltage  
Pin #2 – Signal Voltage  
Pin #gnd – ground

Shield Valve or On/Off Valve – Voltage on pin #1 should be equal to supply voltage when switch is operated in A direction. Voltage on pin #2 should be equal to supply voltage when switch is operated in B direction.

Pin #1 – Signal Voltage  
Pin #2 – Signal Voltage  
Pin #gnd – ground

If none of the valve will operate with electrical signal, verify that there is oil pressure at the valve inlet. Electrical Valves must have pilot supply oil to move the spools.

Possible electronic problems.

Open circuit (broken wire, bad connection or loose connection in switch box).

Shorted to positive, ground, or other.

Incorrect voltage signal from joystick.

**Continued on next sheet**

## TROUBLESHOOTING - CONTINUED

### Hydraulic inspection.

Install 3 pressure gauges, on the valve inlet (use M port, or tee into hose supplying oil from the pump to the inlet), on the workport that is not operating, and on the LS port.

With the spools in Neutral

Gear pump – P should be approximately 200 psi, LS = 0, workport – pressure on cylinder or function.

LS pump – P should equal pump standby pressure, LS = 0, workport – pressure on cylinder or function.

Pressure Comp pump – P should equal pump standby pressure, LS = 0, workport – pressure on cylinder or function.

Gear pump – P should be approximately 200 psi higher than LS, LS should equal workport, workport – pressure on cylinder or function.

LS pump – P should be LS + standby, LS should equal workport, workport – pressure on cylinder or function.

Pressure Comp pump – P should equal pump standby pressure, LS should equal workport, workport – pressure on cylinder or function.

Operate one spool, measure pressures with function at end of travel or stop

Gear pump – P should equal valve relief setting or workport shock valve setting. LS should equal workport. Workport should equal relief setting or workport shock valve setting.

LS pump – P should equal valve relief setting, pump max pressure setting, or workport shock valve setting. LS should equal workport. Workport should equal relief setting, pump max pressure setting, or workport shock valve setting.

Pressure Comp pump – P should equal pump standby pressure, LS should equal workport. Workport should equal pump standby pressure or workport shock valve setting.

Operate more than one spool.

Gear pump – P should approximately 200 psi higher than LS. LS should equal highest workport pressure. Workport – pressure on cylinder or function.

LS pump – P should be LS + standby pressure. LS should equal highest workport pressure. Workport – pressure on cylinder or function.

Pressure Comp pump. P should equal pump standby pressure. LS should equal highest workport pressure. Workport – pressure on cylinder or function.

### Possible hydraulic problems.

Cylinder leak.

LS signal leaking to tank before reaching pump LS port.

Hydraulic system or pump not supplying flow to valve.

# **FIRE SUPPRESSION SYSTEM SECTION**

# FIRE SUPPRESSION 3-POINT MOUNT

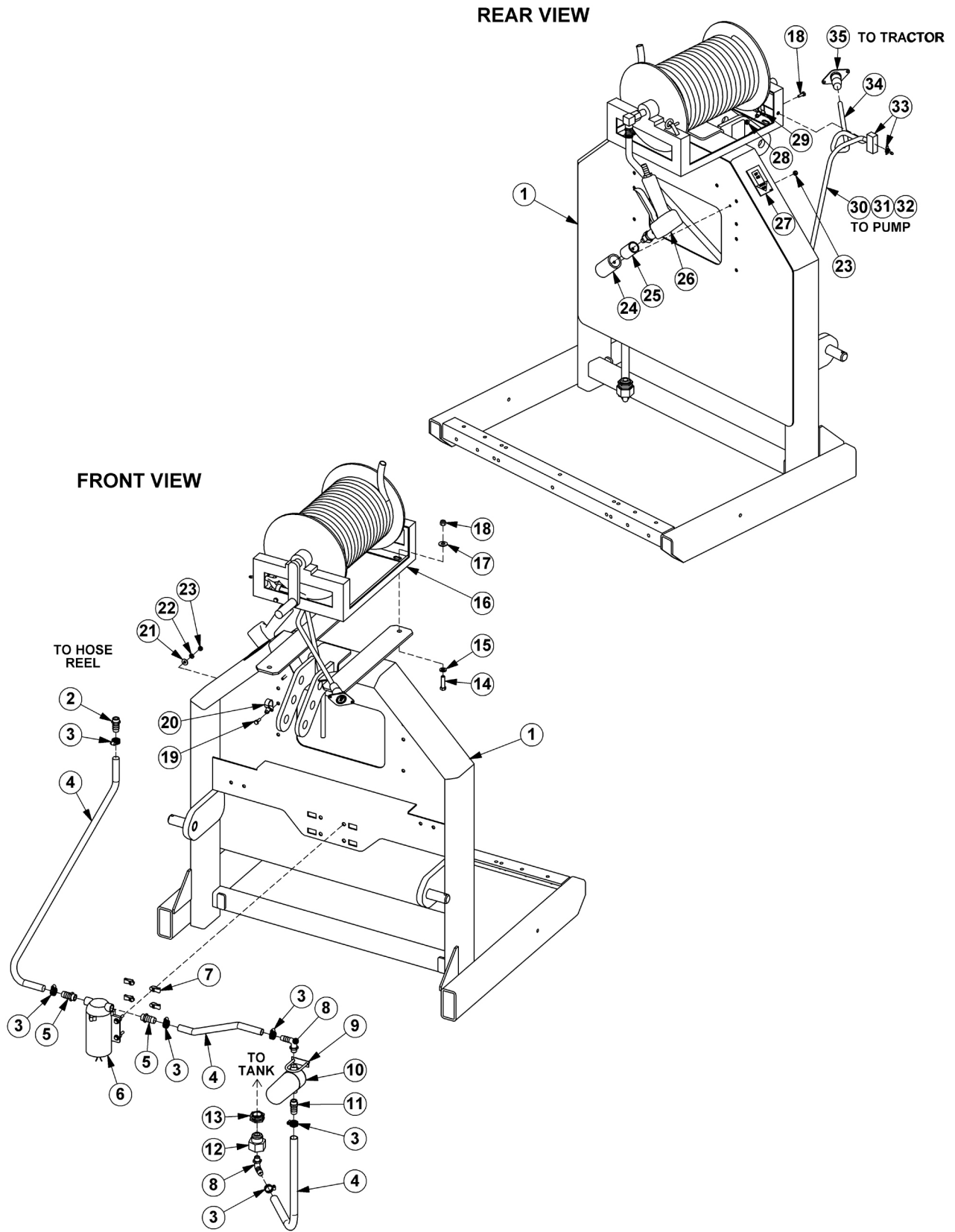



## FIRE SUPPRESSION 3-POINT MOUNT

Continued...

ITEM	PART NO.	QTY.	DESCRIPTION
1	06370137	1	MOUNT,3PNT,FIRE SYS
2	06503108	1	FITTING,1/2"BARB X 1/2"MP
3	35091	6	CLAMP,HOSE,#6
4	06520469	5	HOSE,1/2",BULK (FEET)
5	06503168	2	SWIVEL,1/2"STR,POLY
6	06520359	1	PUMP,LARGE
7	35176	4	U-NUT,1/4"
8	06520367	2	ELBOW,1/2"BARB X 1/2"MP,POLY
9	27329	1	U-BOLT,1/4"
10	06520361	1	FILTER
---	06520351	1	ELEMENT,FILTER
11	06520349	1	FITTING,BARB,HOSE
12	06503169	1	REDUCER,BUSHING (100 & 150 GALLON TANKS ONLY)
13	06520346	1	FITTING,BULKHEAD (50 GALLON TANKS ONLY)
14	21632	4	CAPSCREW,3/8" X 1-1/2",NC
15	21988	4	LOCKWASHER,3/8"
16	06520360	1	HOSE REEL
17	22016	4	FLATWASHER,3/8"
18	21627	4	NYLOCK NUT,3/8",NC
19	21529	2	CAPSCREW,1/4" X 3/4",NC
20	06510258	1	CLAMP,3/4"
21	22014	1	FLATWASHER,1/4"
22	21986	1	LOCKWASHER,1/4"
23	21525	2	HEX NUT,1/4",NC
24	06370121	1	HOLSTER
25	06430090	1	SLEEVE
26	06520366	1	GUN,FIRE SYS
27	6T3222	1	DECAL
28	21527	1	NYLOCK NUT,1/4",NC
29	06510257	1	CLAMP,3/8"
30	28055	5	WIRE,BLACK,14GA (FEET)
31	24200	5	WIRE,RED,14GA (FEET)
32	22802	5	WIRE WRAP (FEET)
33	PT3905A	1	SWITCH
34	06510256	4	CABLE,14GA,4WIRE (FEET)
35	06510255	1	PLUG,7PIN,TRCTR

COMMON RSS

# FIRE SUPPRESSION FRONT MOUNT

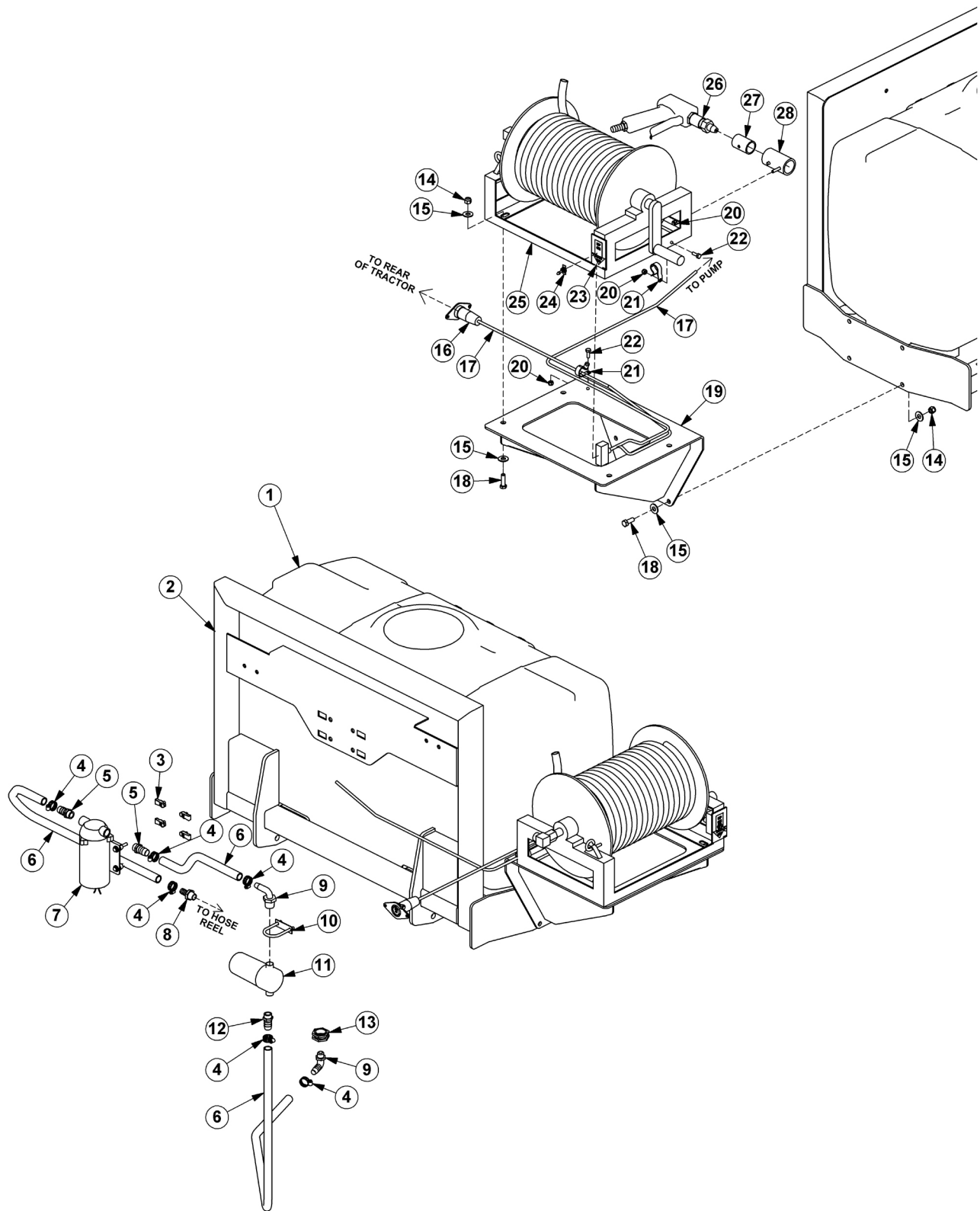

COMMON RSS

## FIRE SUPPRESSION FRONT MOUNT

Continued...

ITEM	PART NO.	QTY.	DESCRIPTION
1	06520342	1	TANK,50 GALLON
2	06370204	1	MNT,TANK,FRNT,50 GALLON
3	35176	4	U-NUT,1/4,3/4 TO CENTER
4	35091	6	CLAMP,HOSE,#6
5	06503168	2	SWIVEL,1/2 STR,POLY
6	06520469	8	HOSE,1/2,SPRAYER
7	06520359	1	PUMP,FIRE KIT
8	06503108	1	FITTING,1/2" BARB X 1/2"MP
9	06520367	2	ELBOW,1/2MPX1/2BARB,POLY
10	27329	1	U-BOLT,1/4X2X1
11	06520361	1	FILTER,FIRE KIT,RAILKUT
---	06520351	1	STRAINER,40 MESH
12	06520349	1	FITTING,BARB,HOSE,WETCUT
13	06520346	1	FITTING,BULKHEAD
14	21627	8	NYLOCK NUT,3/8 NC
15	22016	16	FLATWASHER,3/8,GR8
16	06510255	1	PLUG,7PIN,TRCTR
17	06510256	22	WIRE,14GA,4WIRE (FEET)
18	21631	8	CAPSCREW,3/8X1 1/4, NC,GR8
19	06370207	1	MNT,FIRE SUPPRESSION
20	21527	3	NYLOCK NUT,1/4 NC
21	06510257	2	CLAMP,3/8X1/4,INS
22	21529	2	CAPSCREW,1/4 X 3/4 NC
23	6T3222	1	DECAL,CONTROL,ON-OFF SWITCH
24	PT3905A	1	SWITCH,MOWER
25	06520360	1	HOSE REEL,FIRE KIT,RAILKUT
26	06520366	1	GUN,FIRE KIT,RAILKUT
27	06430090	1	SLEEVE,GUN,FIRE SYS
28	06370121	1	HOLSTER,FIRESYS,RAILKUT

COMMON RSS

# FIRE SUPPRESSION SYSTEM ELECTRICAL SCHEMATIC

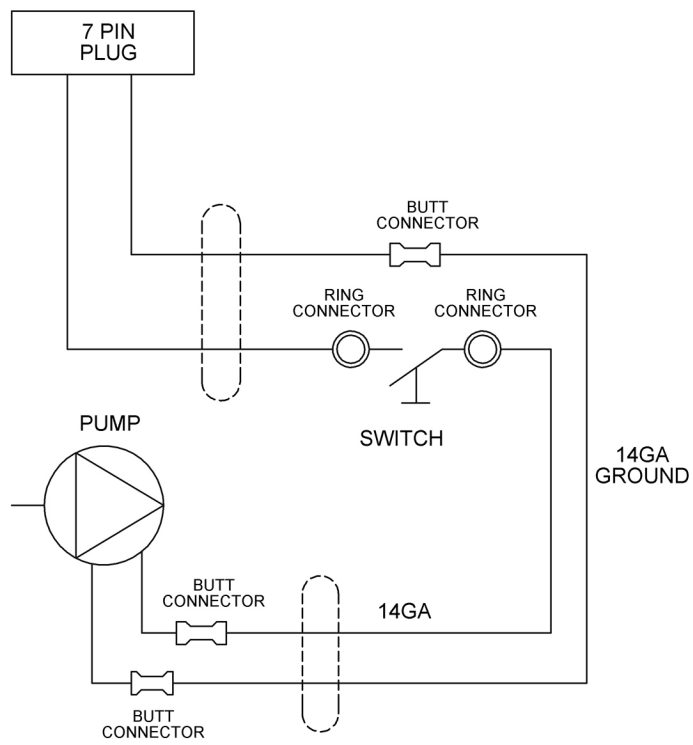

**WETCUT**

**WETCUT  
SECTION**

COMMON RSS

## WETCUT 50 GALLON TANK - 3PNT MOUNT

**INSTALL ITEM 2 INTO ITEM 1 FIRST**

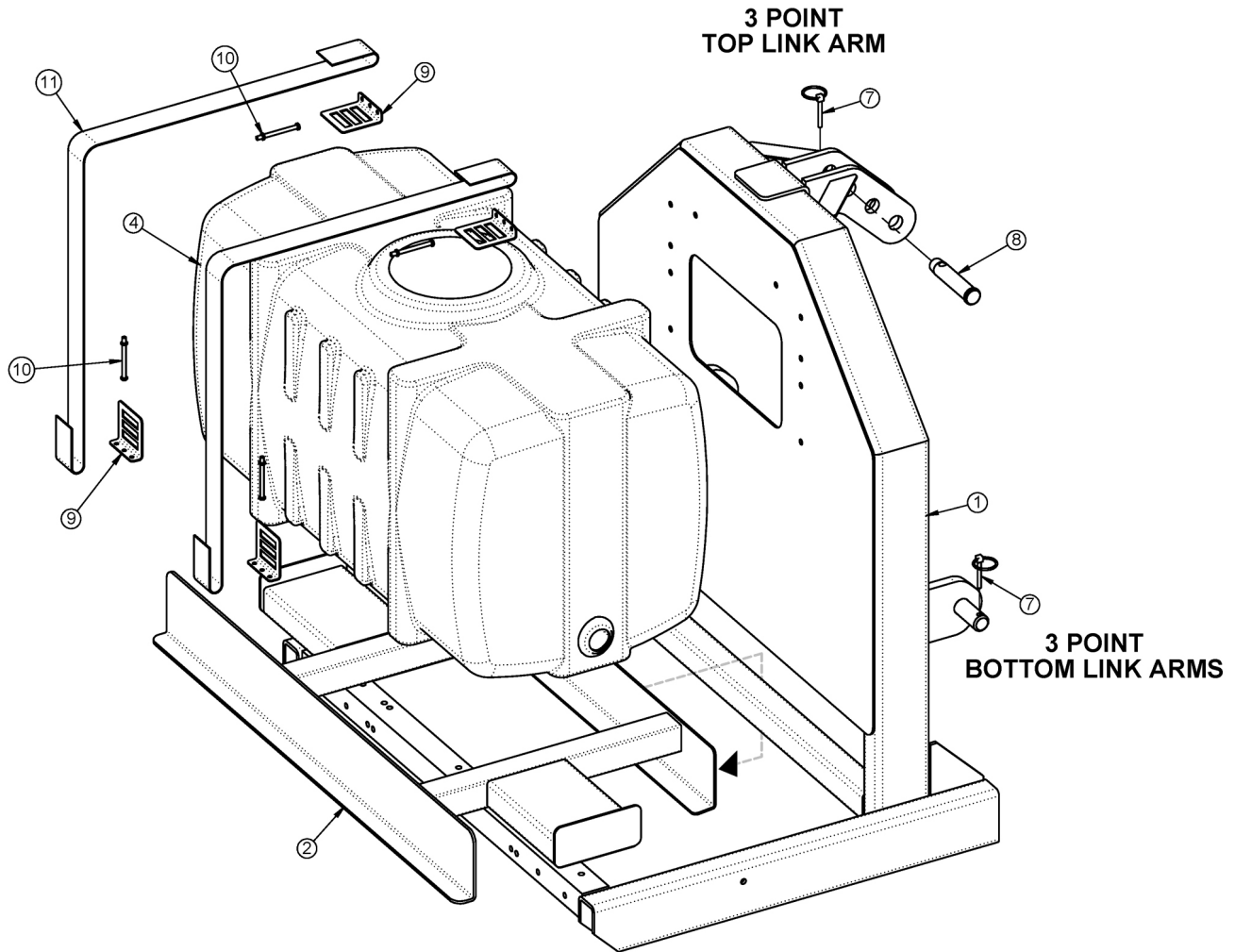

ITEM	PART NO.	QTY.	DESCRIPTION
1	06370128	1	MNT,3PNT,UNI
2	06370136	1	MNT,TANK,50GAL,WETCUT
4	06520342	1	TANK,50GA.,WETCUT
7	RD1032	3	PIN,LYNCH,1/4" X 2"
8	TB1036	1	PIN,SEC BOOM SWIV,1" X 4-11/16"
9	06520343	4	ANCHOR,STRAP,WETCUT
10	06520344	4	BOLT,STRAP,TANK,WETCUT
11	06520345	2	STRAP,TANK,WETCUT

COMMON RSS

## WETCUT 100 OR 150 GALLON TANK - 3PNT MOUNT

INSTALL ITEM 2 INTO ITEM 1 FIRST

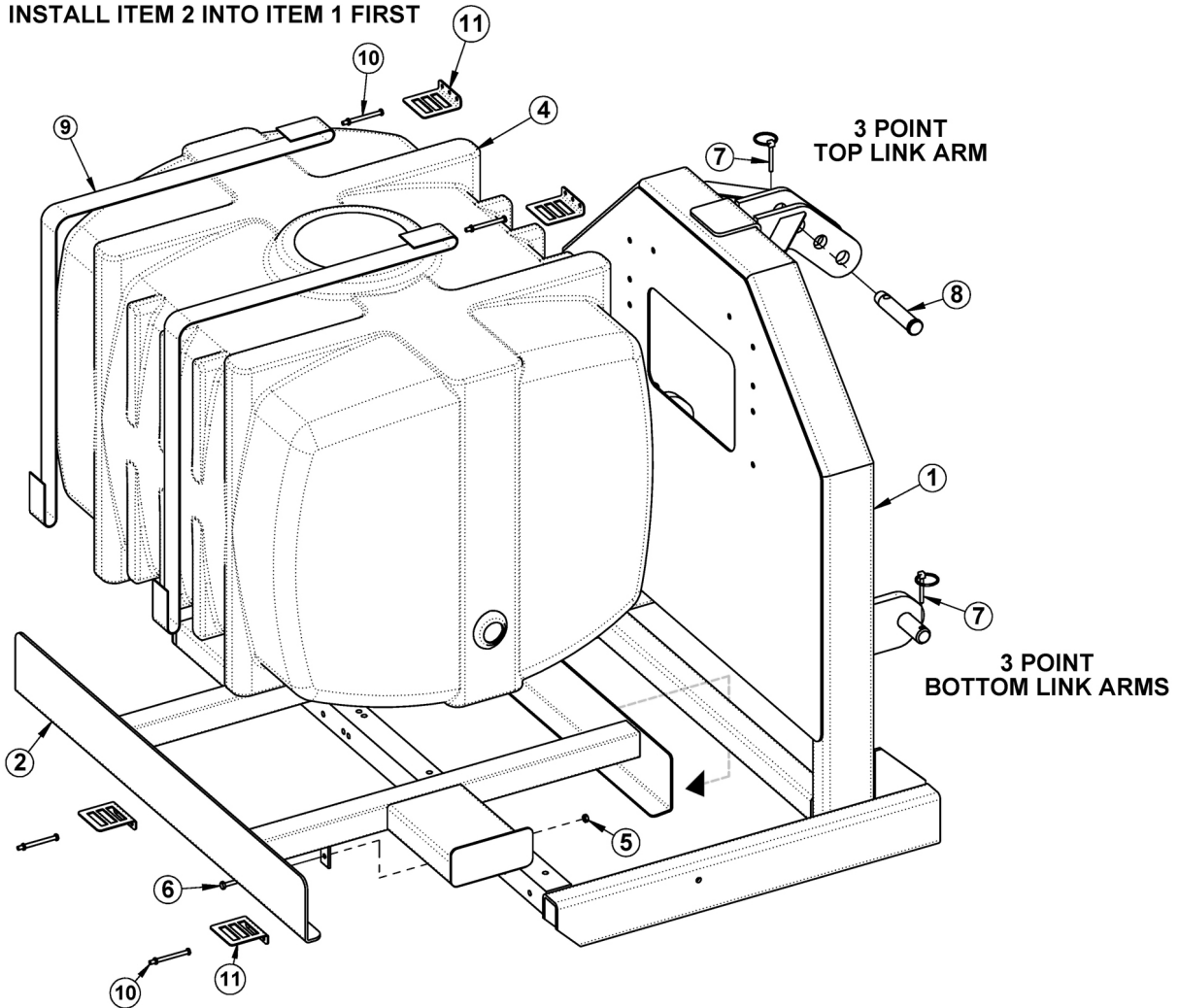

ITEM	PART NO.	QTY.	DESCRIPTION
1	06370128	1	MNT,3PNT,UNI
2	06370138	1	MNT,TANK,100GAL,WETCUT
---	06370139	-	MNT,TANK,150GAL,WETCUT
4	06520372	1	TANK,100GA.,WETCUT
---	06520373	-	TANK,150GA.,WETCUT
5	21527	2	HEX NUT,NYLOCK,1/4",NC
6	21530	2	CAPSCREW,1/4" X 1",NC
7	RD1032	3	PIN,LYNCH 1/4" X 2"
8	TB1036	1	PIN,SEC BOOM SWIV,1" X 4-11/16"
9	06520345	2	STRAP,TANK,WETCUT
10	06520344	4	BOLT,STRAP,TANK,WETCUT
11	06520343	4	ANCHOR,STRAP,WETCUT

COMMON RSS

# WETCUT 3PNT PLUMBING - 50IN MOWERS

1. NOTE ORIENTATION ON ITEM ⑨
2. ITEMS ⑰ ⑱ ⑲ ⑳ CUT FROM SUPPLIED 1/2" HOSE
3. ITEMS ㉑ ㉒ ㉓ CUT FROM SUPPLIED 3/8" HOSE

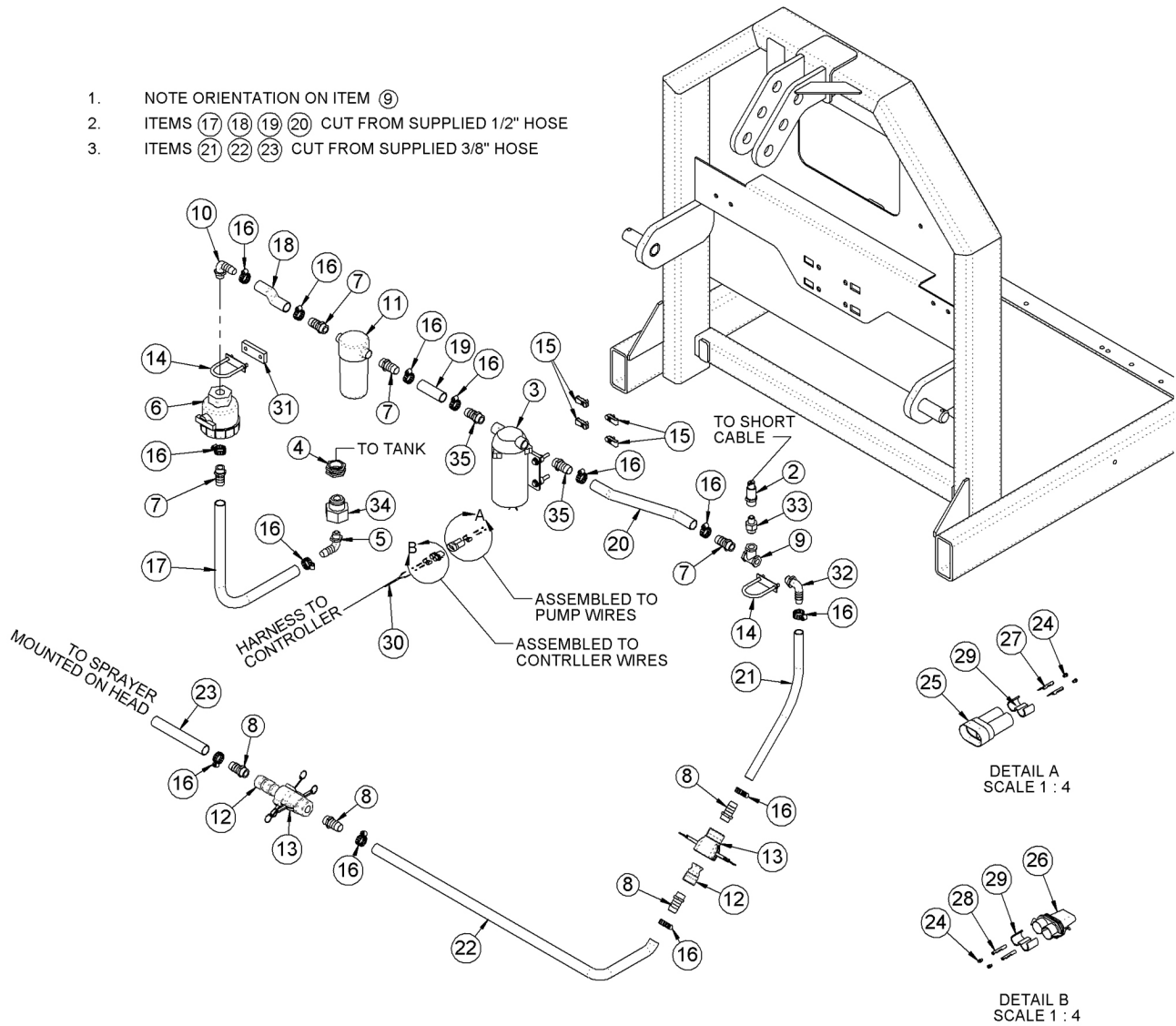



## WETCUT 3PNT PLUMBING - 50IN MOWERS

Continued...

ITEM	PART NO.	QTY.	DESCRIPTION
1	06370128	1	MNT,3PNT,UNI
2	06520336	1	CNTRLR,SENSOR,06520333
3	06520341	1	PUMP,WETCUT
4	06520346	1	FITTING,BULKHEAD,WETCUT (50 GALLON TANKS ONLY)
5	06520347	1	FITTING,ELBOW,WETCUT
6	06520348	1	VLV,BALL,WETCUT
7	06520349	4	FITTING,BARB,HOSE,WETCUT
8	06503173	4	FITTING,1/2MP X 3/8" BARB
9	06520353	1	FITTING,TEE,WETCUT
10	06520367	1	ELBOW,1/2" X 1/2" BARB,POLY
11	06520361	1	FILTER,FIRE KIT,RAILKUT
12	06520400	2	QUIK CPLR,MALE,1/2",WETCUT
13	06520401	2	QUIK CPLR,FEM,1/2",WETCUT
14	27329	2	U-BOLT,1/4" X 1" X 2"
15	35176	4	U-NUT,1/4",3/4" TO CENTER
16	35091	13	CLAMP, HOSE #6
17 - 20	06520469	5	1/2" HOSE (FEET)
21 - 23	06520316	-	3/8" HOSE (INCLUDED WITH SPRAYER)
24	06510051	4	SEAL,16-18GA,METPAK
25	06510052	1	CONN.,BODY,MALE,METRIPACK 150
26	06510053	1	CONN.,BODY,FEM,METRIPACK 150
27	06510054	2	TERMINAL,MALE,16/18GA.METPAK
28	06510055	2	TERMINAL,FEM,16/18GA.METPAK
29	06510056	2	TPA
30	06520337	1	INCLUDED WITH CONTROLLER
31	06401133	1	SPACER,Ø.31" X 1.75" X .38"
32	06503165	1	ELBOW,1/2"MP X 3/8" BARB
33	06520354	1	BUSHING,REDUCER,WETCUT
34	06503169	1	BUSHING,1"MP X 1/2"FP (100 & 150 GALLON TANKS ONLY)
35	06503176	2	FITTING,BARB,3/8"MP X 1/2" BARB

COMMON RSS

# WETCUT 3PNT PLUMBING - LARGE MOWERS

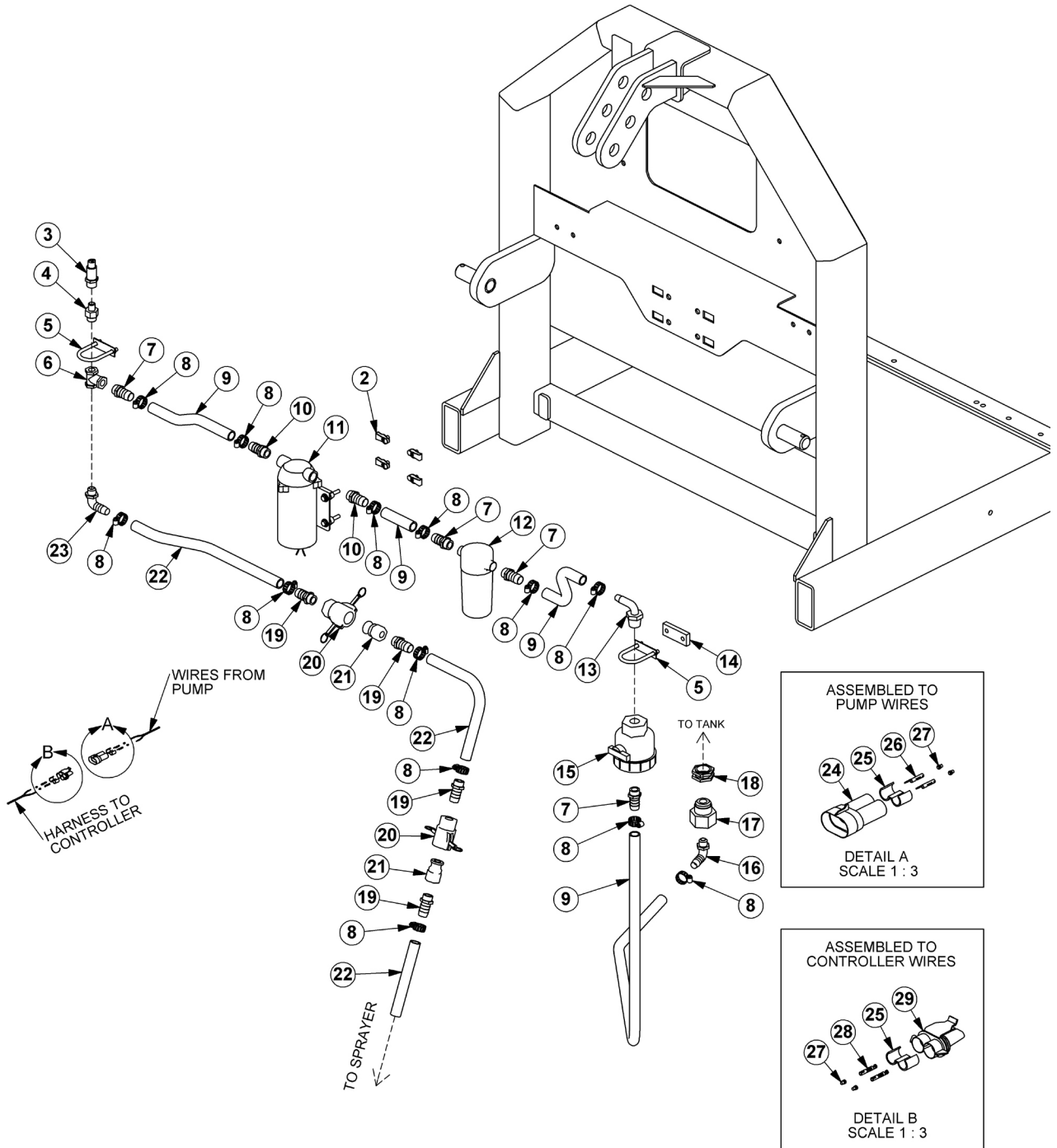

COMMON RSS

## WETCUT 3PNT PLUMBING - LARGE MOWERS

Continued...

ITEM	PART NO.	QTY.	DESCRIPTION
1	06370128	1	MNT,3PNT,UNI
2	35176	4	U-NUT,1/4,3/4 TO CENTER
3	06520336	1	CNTRLR,SENSOR,06520333
4	06520354	1	BUSHING,REDUCER,WETCUT
5	27329	2	U-BOLT,1/4" X 1" X 2"
6	06520353	1	FITTING,TEE,WETCUT
7	06520349	4	FITTING,BARB,HOSE,WETCUT
8	35091	13	CLAMP, HOSE #6
9	06520469	5	1/2" HOSE (FEET)
10	06503168	2	SWIVEL,1/2" STR
11	06520359	1	PUMP,LARGE
12	06520361	1	FILTER,FIRE KIT,RAILKUT
---	06520351	1	STRAINER,40MESH
13	06520367	1	ELBOW,1/2X1/2BARB,POLY
14	06401133	1	SPACER,Ø.31X1.75X.38
15	06520348	1	VLV,BALL,WETCUT
16	06520347	1	FITTING,ELBOW,WETCUT
17	06503169	1	BUSHING,1MPX1/2FP (100 & 150 GALLON TANKS ONLY)
18	06520346	1	FITTING,BULKHEAD,WETCUT (50 GALLON TANKS ONLY)
19	06503173	4	FITTING,BARB,1/2X3/8,WETCUT
20	06520401	2	QUIK CPLR,FEM,1/2,WETCUT
21	06520400	2	QUIK CPLR,MALE,1/2,WETCUT
22	06520316	-	3/8" HOSE (INCLUDED WITH SPRAYER)
23	06503165	1	ELBOW,1/2X3/8BARB,POLY
24	06510052	1	CONN.,BODY,MALE,METRIPACK 150
25	06510056	2	TPA
26	06510054	2	TERMINAL,MALE,16/18GA.METPAK
27	06510051	4	SEAL,16-18GA,METPAK
28	06510055	2	TERMINAL,FEM,16/18GA.METPAK
29	06510053	1	CONN.,BODY,FEM,METRIPACK 150

COMMON RSS

# WETCUT FRONT PLUMBING - 50IN MOWERS

1. NOTE ORIENTATION ON ITEM ⑨
2. ITEMS ⑰ ⑱ ⑲ ⑳ CUT FROM SUPPLIED 1/2" HOSE
3. ITEMS ㉑ ㉒ ㉓ CUT FROM SUPPLIED 3/8" HOSE

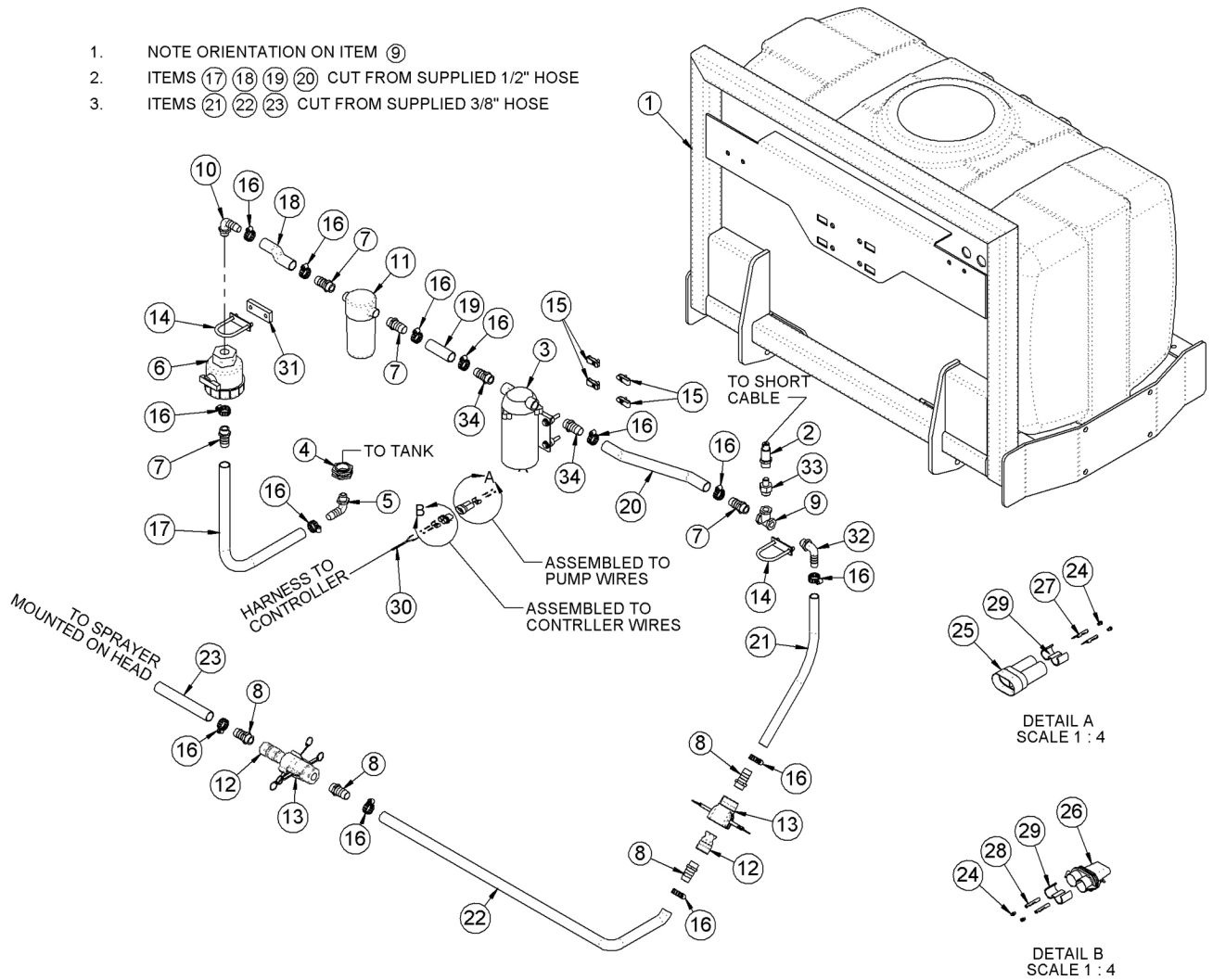

## WETCUT FRONT PLUMBING - 50IN MOWERS

Continued...

ITEM	PART NO.	QTY.	DESCRIPTION
1	06370204	1	MNT,FRONT,UNI
2	06520336	1	CNTRLR,SENSOR,06520333
3	06520341	1	PUMP,WETCUT
4	06520346	1	FITTING,BULKHEAD,WETCUT
5	06520347	1	FITTING,ELBOW,WETCUT
6	06520348	1	VLV,BALL,WETCUT
7	06520349	4	FITTING,BARB,HOSE,WETCUT
8	06503173	4	FITTING,1/2"MP X 3/8"BARB
9	06520353	1	FITTING,TEE,WETCUT
10	06520367	1	ELBOW,1/2"MP X 1/2"BARB,POLY
11	06520361	1	FILTER,FIRE KIT,RAILKUT
---	06520351	1	STRAINER,40MESH
12	06520400	2	QUIK CPLR,MALE,1/2",WETCUT
13	06520401	2	QUIK CPLR,FEM,1/2",WETCUT
14	27329	2	U-BOLT,1/4" X 1" X 2"
15	35176	4	U-NUT,1/4",3/4" TO CENTER
16	35091	13	CLAMP,HOSE #6
17 - 20	06520469	5	1/2" HOSE (FEET)
21 - 23	06520316	-	3/8" HOSE (INCLUDED WITH SPRAYER)
24	06510051	4	SEAL,16-18GA,METPAK
25	06510052	1	CONN.,BODY,MALE,METRIPACK 150
26	06510053	1	CONN.,BODY,FEM,METRIPACK 150
27	06510054	2	TERMINAL,MALE,16/18GA.METPAK
28	06510055	2	TERMINAL,FEM,16/18GA.METPAK
29	06510056	2	TPA
30	06520337	1	INCLUDED WITH CONTROLLER
31	06401133	1	SPACER,Ø.31" X 1.75" X .38"
32	06503165	1	ELBOW,1/2"MP X 3/8"BARB,POLY
33	06520354	1	BUSHING,REDUCER,WETCUT
34	06503176	2	FITTING,3/8"MP X 1/2"BARB

COMMON RSS

# WETCUT FRONT PLUMBING - LARGE MOWERS

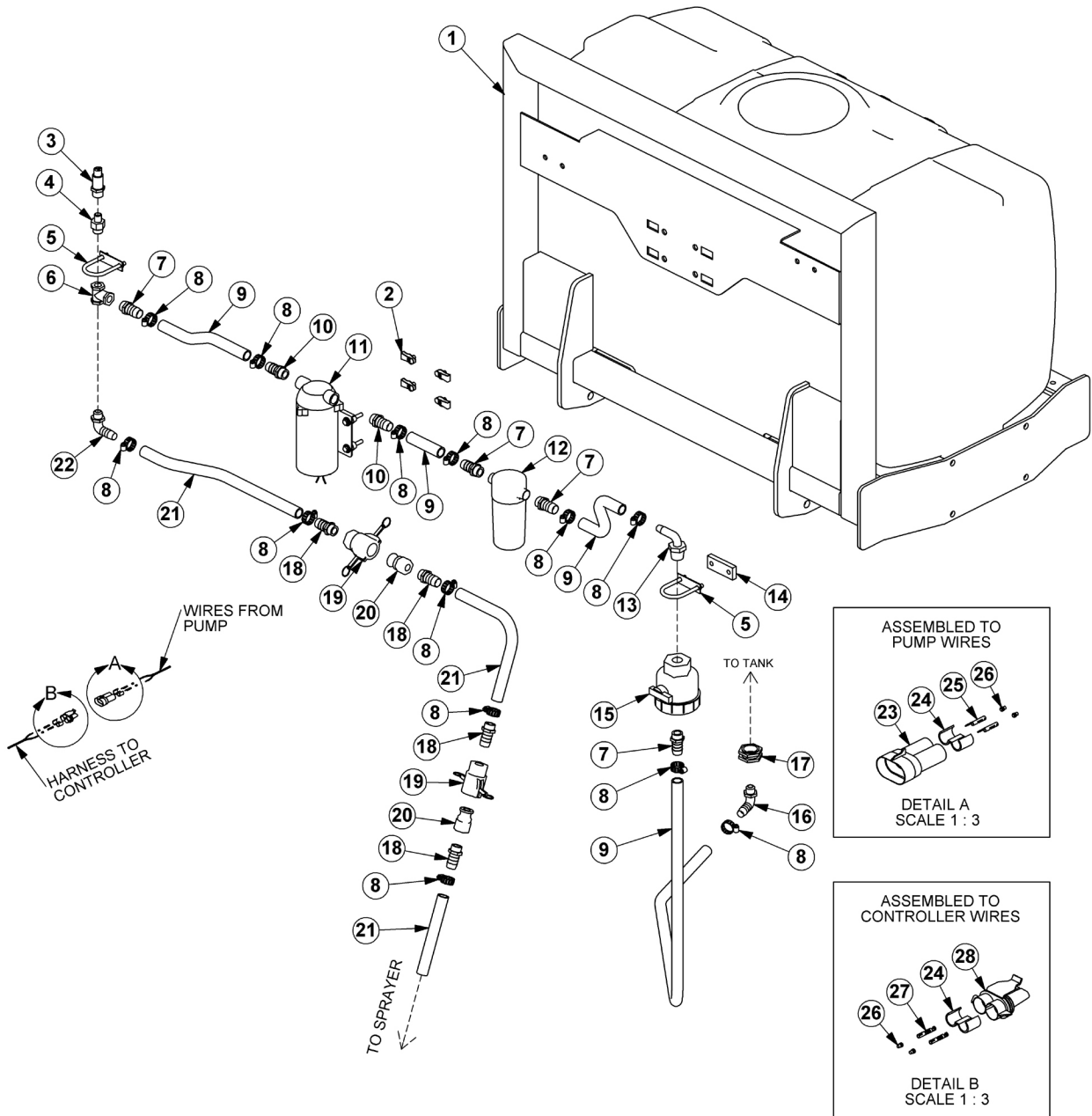

## WETCUT FRONT PLUMBING - LARGE MOWERS

Continued...

ITEM	PART NO.	QTY.	DESCRIPTION
1	06370204	1	MNT,FRONT,UNIV
2	35176	4	U-NUT,1/4,3/4 TO CENTER
3	06520336	1	CNTRLR,SENSOR,06520333
4	06520354	1	BUSHING,REDUCER,WETCUT
5	27329	2	U-BOLT,1/4" X 1" X 2"
6	06520353	1	FITTING,TEE,WETCUT
7	06520349	4	FITTING,BARB,HOSE,WETCUT
8	35091	13	CLAMP, HOSE #6
9	06520469	5	1/2" HOSE (FEET)
10	06503168	2	SWIVEL,1/2" STR
11	06520359	1	PUMP,LARGE
12	06520361	1	FILTER,FIRE KIT,RAILKUT
---	06520351	1	STRAINER,40MESH
13	06520367	1	ELBOW,1/2X1/2BARB,POLY
14	06401133	1	SPACER,Ø.31X1.75X.38
15	06520348	1	VLV,BALL,WETCUT
16	06520347	1	FITTING,ELBOW,WETCUT
17	06520346	1	FITTING,BULKHEAD,WETCUT
18	06503173	4	FITTING,BARB,1/2X3/8,WETCUT
19	06520401	2	QUIK CPLR,FEM,1/2,WETCUT
20	06520400	2	QUIK CPLR,MALE,1/2,WETCUT
21	06520316	-	3/8" HOSE (INCLUDED WITH SPRAYER)
22	06503165	1	ELBOW,1/2X3/8BARB,POLY
23	06510052	1	CONN.,BODY,MALE,METRIPACK 150
24	06510056	2	TPA
25	06510054	2	TERMINAL,MALE,16/18GA.METPAK
26	06510051	4	SEAL,16-18GA,METPAK
27	06510055	2	TERMINAL,FEM,16/18GA.METPAK
28	06510053	1	CONN.,BODY,FEM,METRIPACK 150

COMMON RSS

# WETCUT 50IN SPRAYER HEAD ASSEMBLY

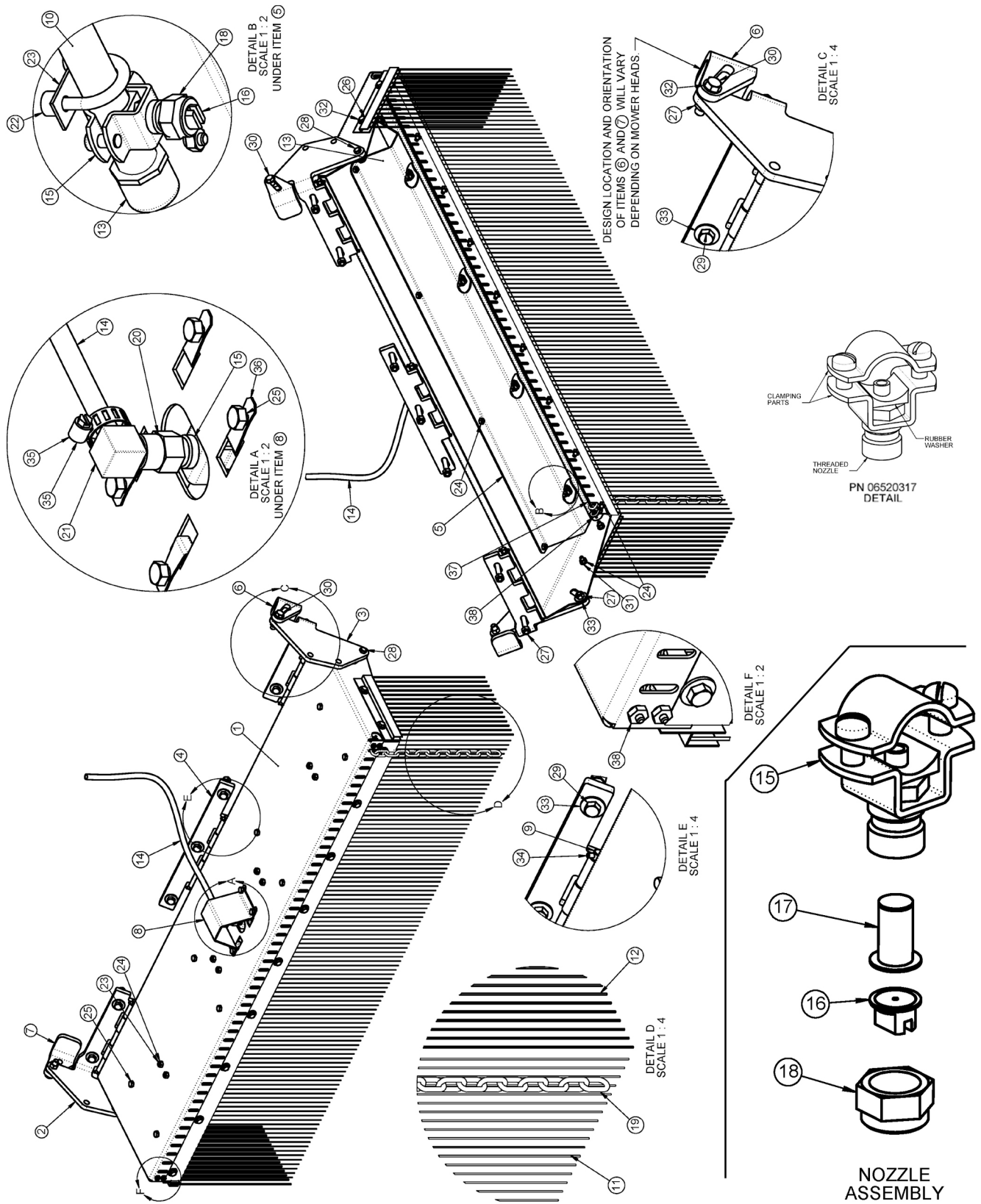



## WETCUT 50IN SPRAYER HEAD ASSEMBLY

Continued...

ITEM	PART NO.	QTY.	DESCRIPTION
1	06370105	1	HOOD,SPRAYER
2	06370106	1	HINGE,LH,SPRAYER
3	06370107	1	HINGE,RH,SPRAYER
4	06370108	1	HINGE,CNTR,SPRAYER
5	06410668	1	GUARD,SPRAYER,WETCUT
6	06410753	1	MNT,RH,WET CUT (FLAIL)
---	06410942	1	MNT,RH,WET CUT (ROTARY)
7	06410754	1	MNT,LH,WET CUT (FLAIL)
---	06410943	1	MNT,LH,WET CUT (ROTARY)
8	06410796	1	GUARD,HOSE,WETCUT
9	06420069	3	PIN,HINGE,WET CUT
10	06497003	1	TUBE,LG,SPRAYER
11	06499012	1	SKIRT,ANTI SPRAY,50
12	06499013	2	SKIRT,ANTI SPRAY,7
13	06520314	2	TUBE,CAP,SPRAYER
14	06520316	15	HOSE,SPRAYER (FEET)
15	06520317	5	NOZZLE,SPRAYER
16	06520319	4	TIP,NOZZLE,SPRAYER
17	06520320	4	FILTER,NOZZLE,SPRAYER
18	06520321	4	NUT,NOZZLE,SPRAYER
19	06520322	49	CHAIN,.18" X 1.31" X 13LINKS
20	06520381	1	ADAPTER,1/4"NPT,WETCUT
21	06520382	1	ELBOW,BARB,3/8" X 1/4"NPT
22	06520383	8	SPACER,.50"O.D. X .252" I.D. X .38",NYLON
23	32550	4	U-BOLT,1/4" X 1" X 1" X 1-3/4"
24	21527	29	HEX NUT,NYLOCK,1/4",NC
25	21528	12	CAPSCREW,1/4" X 1/2",NC
26	21529	13	CAPSCREW,1/4" X 3/4",NC
27	21625	11	HEX NUT,3/8",NC
28	21630	2	CAPSCREW,3/8" X 1",NC
29	21634	7	CAPSCREW,3/8" X 2",NC
30	21632	2	CAPSCREW,3/8" X 1-1/2",NC
31	21986	4	LOCKWASHER,1/4"
32	22014	15	FLATWASHER,1/4"
33	22016	9	FLATWASHER,3/8",GR8
34	34698	6	ROLL PIN, PLAIN, 3/16" X 7/8"
35	35091	1	CLAMP,HOSE #6
36	35176	4	U-NUT,1/4",3/4" TO CENTER
37	06520376	5	CABLE,3/16"
38	06537022	2	U-BOLT,CABLE,3/16"

COMMON RSS

# WETCUT 60IN SPRAYER HEAD ASSEMBLY

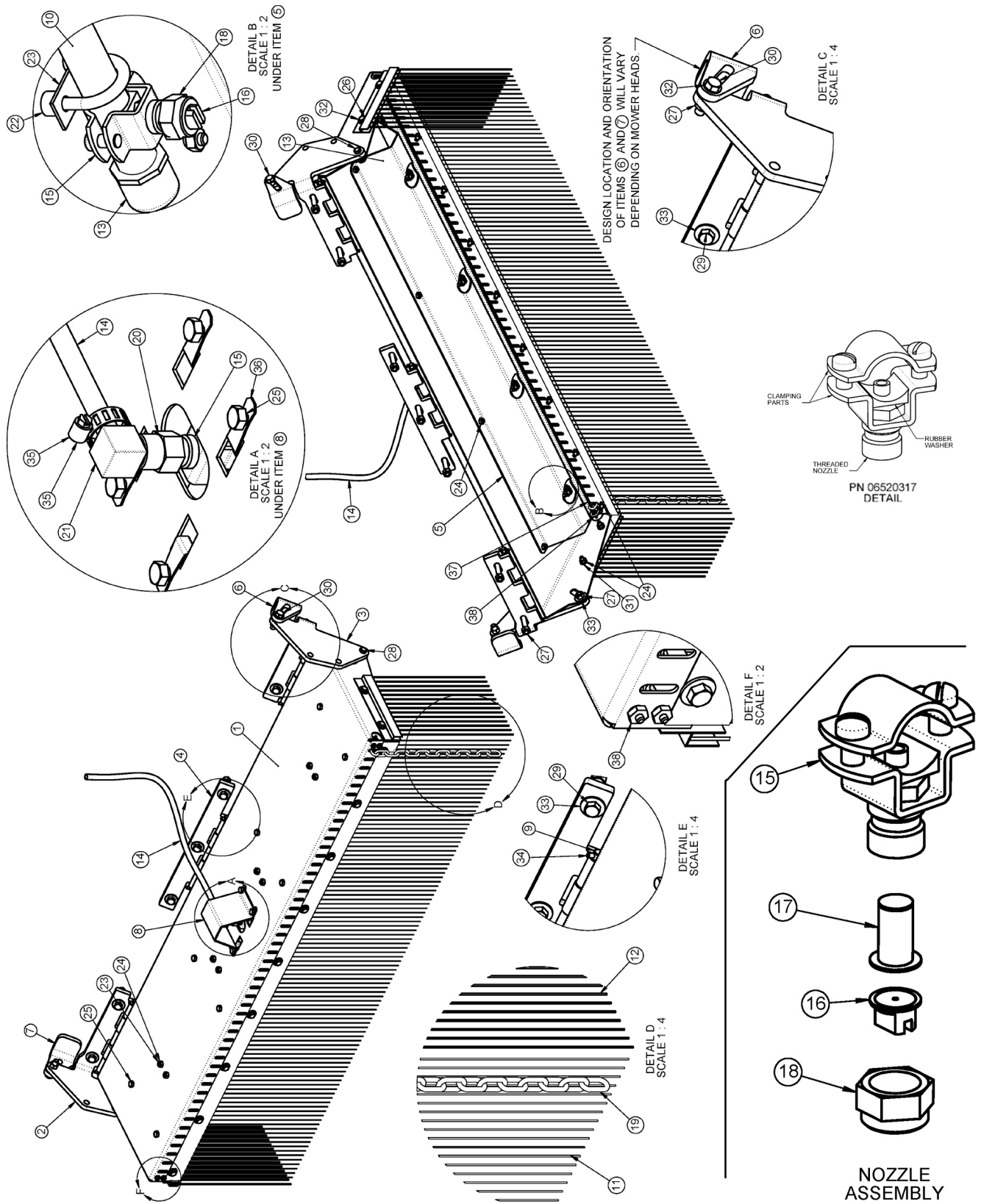

## WETCUT 60IN SPRAYER HEAD ASSEMBLY

Continued...

ITEM	PART NO.	QTY.	DESCRIPTION
1	06370210	1	HOOD,SPRAYER
2	06370106	1	HINGE,LH,SPRAYER
3	06370107	1	HINGE,RH,SPRAYER
4	06370108	1	HINGE,CNTR,SPRAYER
5	06411234	1	GUARD,SPRAYER,WETCUT
6	06410753	1	MNT,RH,WET CUT (FLAIL)
---	06410942	1	MNT,RH,WET CUT (ROTARY)
7	06410754	1	MNT,LH,WET CUT (FLAIL)
---	06410943	1	MNT,LH,WET CUT (ROTARY)
8	06410796	1	GUARD,HOSE,WETCUT
9	06420069	3	PIN,HINGE,WET CUT
10	06497009	1	TUBE,LG,SPRAYER
11	06499018	1	SKIRT,ANTI SPRAY,60
12	06499013	2	SKIRT,ANTI SPRAY,7
13	06520314	2	TUBE,CAP,SPRAYER
14	06520316	15	HOSE,SPRAYER (FEET)
15	06520317	6	NOZZLE,SPRAYER
16	06520319	5	TIP,NOZZLE,SPRAYER
17	06520320	5	FILTER,NOZZLE,SPRAYER
18	06520321	5	NUT,NOZZLE,SPRAYER
19	06520322	61	CHAIN,.18" X 1.31" X 13LINKS
20	06520381	1	ADAPTER,1/4"NPT,WETCUT
21	06520382	1	ELBOW,BARB,3/8" X 1/4"NPT
22	06520383	10	SPACER,.50"O.D. X .252" I.D. X .38",NYLON
23	32550	5	U-BOLT,1/4" X 1" X 1" X 1-3/4"
24	21527	33	HEX NUT,NYLOCK,1/4",NC
25	21528	15	CAPSCREW,1/4" X 1/2",NC
26	21529	13	CAPSCREW,1/4" X 3/4",NC
27	21625	13	HEX NUT,3/8",NC
28	21630	2	CAPSCREW,3/8" X 1",NC
29	21634	7	CAPSCREW,3/8" X 2",NC
30	21632	4	CAPSCREW,3/8" X 1-1/2",NC
31	21986	4	LOCKWASHER,1/4"
32	22014	33	FLATWASHER,1/4"
33	22016	11	FLATWASHER,3/8",GR8
34	34698	6	ROLL PIN, PLAIN, 3/16" X 7/8"
35	35091	1	CLAMP,HOSE #6
36	35176	4	U-NUT,1/4",3/4" TO CENTER
37	06520376	6	CABLE,3/16" (FEET)
38	06537022	2	U-BOLT,CABLE,3/16"

COMMON RSS

# WETCUT CABLES

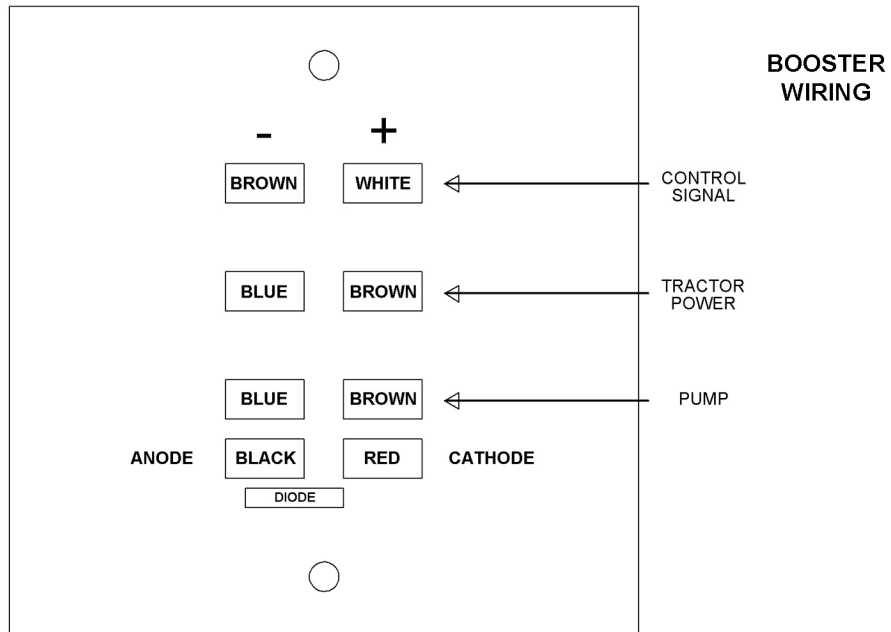
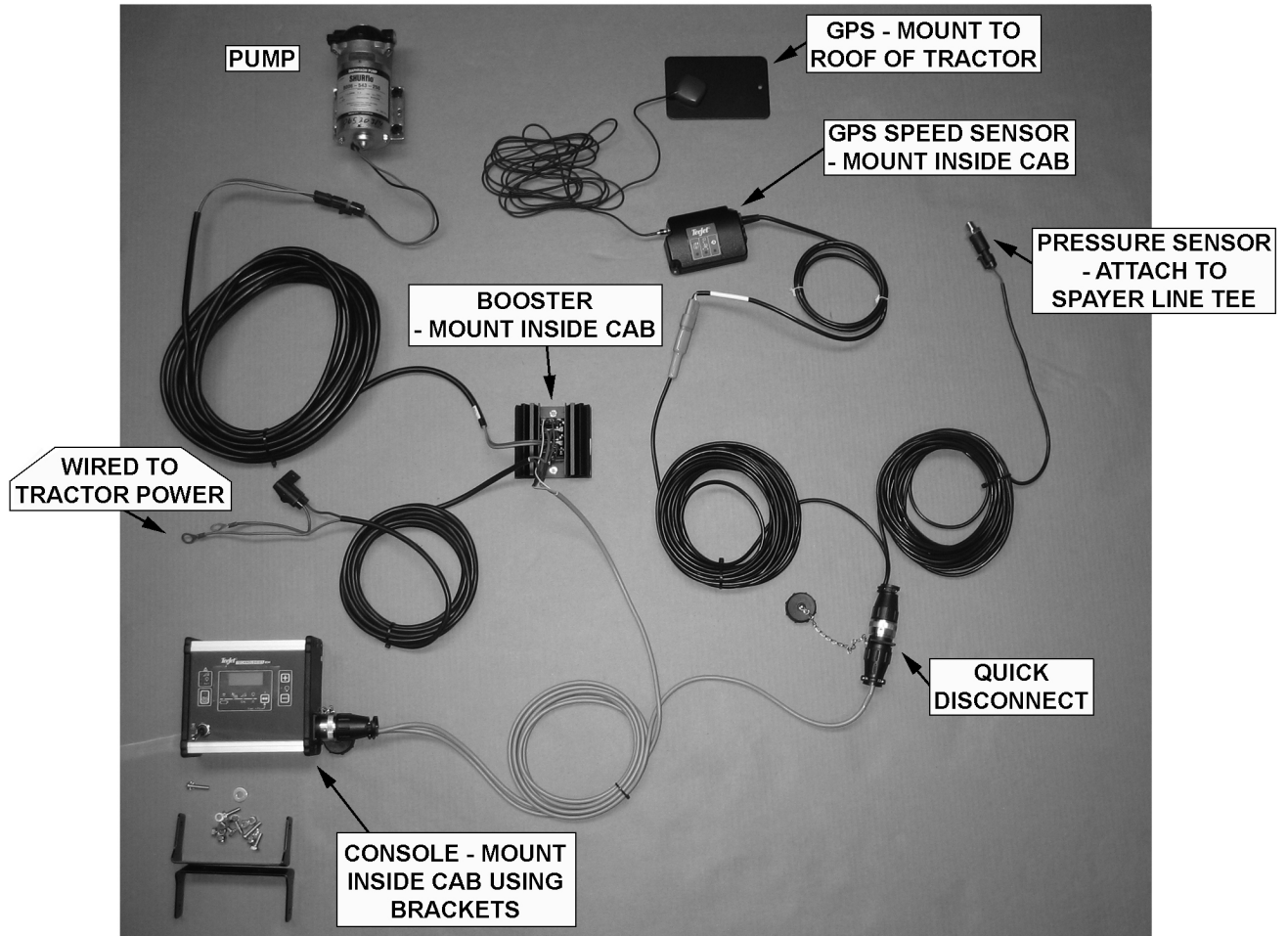

# **WARRANTY SECTION**



## WARRANTY INFORMATION

Tiger Corporation, 3301 N. Louise, Sioux Falls, South Dakota, warrants to the original Retail Customer, the new Tiger equipment is free of defects in material and workmanship. Any part of equipment that in Tiger's judgement, show evidence of such defects will be repaired or replaced without charge, provided that the failure of part(s) shall have occurred within twelve (12) months from the date of delivery of said equipment to the Retail Customer. Expendable components such as knives, oil, chain sprockets, skid shoes, knife mounting disks and the like are excluded but not limited to this warranty.

The Retail Customer must pay the transportation cost to and from the Tiger Dealer's service shop for warranty service. Warranty service will be performed by the Tiger Dealer from whom the equipment was purchased, during service shop regularly scheduled days and hours of operation.

All Tiger obligation under this warranty shall be terminated if the equipment is modified or altered in ways not approved in writing by Tiger, if repair parts other than genuine Tiger repair parts have been used, or if the equipment has been subject to misuse, neglect, accident, improper maintenance or improper operation.

Tiger Corporation reserves the right to make improvements in design or changes in specification at any time without incurring any obligation to owners of equipment previously sold.

No agent or person has authority to alter, add to or waive the above warranties which are agreed to be in the only warranties, representations or promises, expressed or implied, as to the quality or performance of the products covered and which do not include any implied warranty of merchantability or fitness. In no event will Tiger be liable for incidental or consequential damages or injuries, including, but not limited to, loss of profits, rental or substitute equipment or other commercial loss.

**THERE ARE NO WARRANTIES WHICH EXTEND  
BEYOND THOSE EXPRESSED HEREIN.**

It is the Purchasers obligation to sign the warranty registration form **AFTER** he / she has Read and Understands the Operation and Safety Instructions stated within this manual.

## **ONE LAST WORD**

This manual cannot possibly cover all of the potentially hazardous situations you will encounter. By being familiar with the safety rules, operating and maintenance instructions in this manual you can help prevent accidents. The objective of this manual is to help make you a better operator. Remember, **SAFETY IS YOU!**



1012

Your safety and the safety of those around you depends on **YOU**. Common sense should play a large role in the operation of this machine.

Since we at Tiger Corporation are constantly striving to improve our products, we reserve the right to change specifications or design at any time.



## TO THE OWNER / OPERATOR / DEALER



To keep your implement running efficiently and safely, read your manual thoroughly and follow these directions and the Safety Messages in this manual and on the machine. The table of contents clearly identifies each section where you can easily find the information you need.

The Occupational Safety and Health Act (OSHA 1928.51 subpart C) makes the following minimum requirements for tractor operators.

### **OWNER REQUIREMENTS:**

1. Provide a Roll-Over-Protective Structure that meets the requirements of this Standard; and
2. Provide Seatbelts that meet the requirements of this Standard and SAE J3C; and
3. Ensure that each employee uses such Seatbelt while the tractor is moving; and
4. Ensure that each employee tightens the Seatbelt sufficiently to confine the employee to the protected area provided by the ROPS.

### **OPERATOR REQUIREMENTS:**

1. Securely fasten seatbelt if the tractor has a ROPS.
2. Where possible, avoid operating the tractor near steep ditches, embankments, and holes.
3. Reduce speed when turning, crossing slopes, and on rough, slick, or muddy surfaces.
4. Stay off slopes too steep for safe operation.
5. Watch where you are going – especially at row ends, on roads, and around trees.
6. Do Not permit others to ride.
7. Operate the tractor smoothly – no jerky turns, starts, or stops.
8. Hitch only to the draw-bar and hitch points recommended by the tractor manufacturer.
9. When the tractor is stopped, set brakes securely and use park lock, if available



Printed in USA  
© Tiger Corporation