



# BENGAL BRUTE ASSEMBLIES

KUBOTA M126-135GX

Current as of 11/30/2012

---

## PARTS LISTING WITH MOUNTING AND OPERATING INSTRUCTIONS

---

**Tiger Corporation**  
3301 N. Louise Ave.  
Sioux Falls, SD 57107  
1-800-843-6849  
1-605-336-7900  
[www.tiger-mowers.com](http://www.tiger-mowers.com)

**06070012**

# TO THE OWNER / OPERATOR / DEALER

All implements with moving parts are potentially hazardous. There is no substitute for a cautious, safe-minded operator who recognizes the potential hazards and follows reasonable safety practices. The manufacturer has designed this implement to be used with all its safety equipment properly attached to minimize the chance of accidents.

**BEFORE YOU START!!** Read the safety messages on the implement and shown in this manual. Observe the rules of safety and use common sense!

**READ AND UNDERSTAND THIS MANUAL! Non-English speaking operators will need to GET THE MANUAL TRANSLATED as needed!**



# DANGER

**FAILING TO FOLLOW SAFETY MESSAGES AND OPERATING INSTRUCTIONS CAN CAUSE SERIOUS BODILY INJURY OR EVEN DEATH TO OPERATOR AND OTHERS IN THE AREA.**



1. Study and understand Operator's Manuals, Safety Decals, and Instructional Decals for tractor and implement to prevent misuse, abuse, and accidents. Practice before operating in a confined area or near passersby.

● Learn how to stop engine suddenly in an emergency. Be alert for passersby and especially children

2. Allow no children on or near folding mower or tractor. Allow no riders on tractor or implement. Falling off may cause serious injury or death from being run over by tractor or mower or contact with rotating blades.

3. Operate only with tractor having Roll-Over Protective Structure (ROPS) and with seat belt securely fastened to prevent injury and possible death from falling off or tractor overturn.

● Personal Protective Equipment such as Hard Hat, Safety Glasses, Safety Shoes, & Ear Plugs are recommended.

4. Block up or support raised machine and all lifted components securely before putting hands or feet under or working underneath any lifted component to prevent crushing injury or death from sudden dropping or inadvertent operation of controls. Make certain area is clear before lowering or folding

5. Before transporting, put Lift Lever in detent or full-lift position. Install Transport Safety Devices securely on folding mowers. Put Booms securely in Transport Rest.

● Folding and Boom Mowers have raised center of gravity. Slow down when turning and on hillsides.

6. Make certain that SMV sign, warning lights, and reflectors are clearly visible. Follow local traffic codes.

7. Never operate with Cutting Head or Folding Section raised if passersby, bystanders, or traffic are in the area to reduce possibility of injury or death from objects thrown by Blades under Guards or mower structure.

8. Before dismounting, secure implement in transport position or lower to ground.

● Put tractor in park or set brake, disengage PTO, stop engine, remove key, and wait until noise of rotation has ceased to prevent crushing by entanglement in rotating parts which could cause injury or death.

● Never mount or dismount a moving vehicle. Crushing from rollover may cause serious injury or death.



02967827

Warranty Information: Read and understand the complete Warranty Statement found in this manual. Fill out the Warranty Registration form in full and return it within 90 days. Make certain the Serial Number of the machine is recorded on the Warranty Card, and form that you retain.

# FORWARD

This manual contains information about many features of the Tiger mowing and roadside maintenance equipment. Some of these include: Safety precautions, Assembly instructions, Operations, Maintenance and Parts. This manual will also assist you in the proper break-in, daily care, and troubleshooting of your new mower.

We recommend that you read carefully the entire manual before operating the unit. Also, time spent in becoming fully acquainted with its performance features, adjustments, and maintenance schedules will be repaid in a long and satisfactory life of the equipment.

## **Troubleshooting - Please, before you call, help us to help you!**

Please look at the equipment to observe what is happening, then:

- Classify the problem
  - Hydraulic, electrical or mechanical - Read the trouble shooting section
  - Tractor or Truck chassis - Contact vehicle dealer
  
- If unable to correct the problem yourself, contact your local Tiger Dealer after gathering:
  - Machine model \_\_\_\_\_
  - Serial number \_\_\_\_\_
  - Dealer name \_\_\_\_\_
  - Detailed information about the problem including results of troubleshooting

**Attention Owner / Operator / Dealer:** It is your obligation to read, and understand, the warranty information section located at the back of this manual denoting that the purchaser understands the safety issues relating to this machine and has received and will read a copy of this manual.

If at any time, you have a service problem with your Tiger mower, Contact your local dealer for service and parts needed.

MANUFACTURED BY:

**Tiger Corporation**

3301 N. Louise Ave.

Sioux Falls, SD 57107

1-800-843-6849

1-605-336-7900

www.tiger-mowers.com

DISTRIBUTED BY:

\_\_\_\_\_

1- \_\_\_\_\_ - \_\_\_\_\_ - \_\_\_\_\_

1- \_\_\_\_\_ - \_\_\_\_\_ - \_\_\_\_\_



# TABLE OF CONTENTS

SAFETY SECTION_____	1
ASSEMBLY / MOUNTING SECTION_____	2
OPERATION SECTION_____	3
MAINTENANCE SECTION_____	4
PARTS SECTION_____	5
COMMON PARTS SECTION_____	6
WARRANTY INFORMATION_____	7



1012

**This symbol means:**

**CAUTION – YOUR SAFETY IS AT RISK!**

When you see this symbol, read and follow the associated instructions carefully or personal injury or damage may result.

Tiger is a registered trademark.





# **SAFETY SECTION**

# SAFETY

A safe and careful operator is the best operator. Safety is of primary importance to the manufacturer and should be to the owner / operator. Most accidents can be avoided by being aware of your equipment, your surroundings, and observing certain precautions. The first section of this manual includes a list of Safety Messages that, if followed, will help protect the operator and bystanders from injury or death. Read and understand these Safety Messages before assembling, operating or servicing this mower. This equipment should only be operated by those persons who have read the Manual, who are responsible and trained, and who know how to do so safely and responsibly.

The Safety Alert Symbol combined with a Signal Word, as seen below, is used throughout this manual and on decals which are attached to the equipment. The Safety Alert Symbol means: **“ATTENTION! BECOME ALERT! YOUR SAFETY IS INVOLVED!”** The symbol and signal word are intended to warn the owner / operator of impending hazards and the degree of possible injury when operating this equipment.

**Practice all usual and customary safe working precautions and above all -- remember safety is up to YOU! Only YOU can prevent serious injury or death from unsafe practices.**



This is the Safety Alert Symbol. When you see this symbol on your machine or in these instructions, be alert to the potential for personal injury.

CAUTION!



The lowest level of Safety Message; warns of possible injury. Decals located on the equipment with this signal word are Black and Yellow.

WARNING!



Serious injury or possible death! Decals are Black and Orange.

DANGER!



Imminent death / critical injury. Decals are Red and White.

**READ, UNDERSTAND, and FOLLOW** the following Safety Messages. Serious injury or death may occur unless care is taken to follow the warnings and instructions stated in the Safety Messages. Always use good common sense to avoid hazards. (SG-2)

**SAFETY INSTRUCTIONS**





# SAFETY

**PELIGRO!**



Si no lee Ingles, pida ayuda a alguien que si lo lea para que le traduzca las medidas de seguridad. \*UI /5+

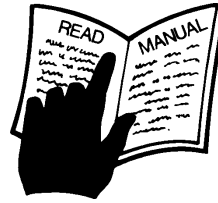

**¡ LEA EL INSTRUCTIVO!**

**DANGER!**



Never operate the Tractor or Implement until you have read and completely understand this Manual, the Tractor Operator's Manual, and each of the Safety Messages found in the Manual or on the Tractor and Implement. Learn how to stop the tractor engine suddenly in an emergency! Never allow inexperienced or untrained personnel to operate the Tractor and Implement without supervision. Make sure the operator has fully read and understood the manuals prior to operation. \*UI /6+



**WARNING!**



Always maintain the safety decals in good readable condition. If the decals are missing, damaged, or unreadable, obtain and install replacement decals immediately. \*UI /7+

**WARNING!**



Make certain that the "Slow Moving Vehicle" (SMV) sign is installed in such a way as to be clearly visible and legible. When transporting the Equipment use the Tractor flashing warning lights and follow all local traffic regulations. \*UI /8+

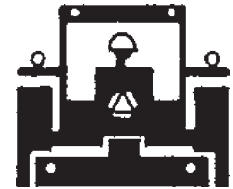

**WARNING!**



Operate this Equipment only with a Tractor equipped with an approved roll-over-protective system (ROPS). Always wear seat belts. Serious injury or even death could result from falling off the tractor--particularly during a turnover when the operator could be pinned under the ROPS. \*UI /9+



**WARNING!**



Do not modify or alter this Implement. Do not permit anyone to modify or alter this Implement, any of its components or any Implement function. \*UI /:+

**DANGER!**



BEFORE leaving the tractor seat, always engage the brake and/or set the tractor transmission in parking gear, disengage the PTO, stop the engine, remove the key, and wait for all moving parts to stop. Place the tractor shift lever into a low range or parking gear to prevent the tractor from rolling. Never dismount a Tractor that is moving or while the engine is running. Operate the Tractor controls from the tractor seat only.

\*\*\*\*\*UI /:+

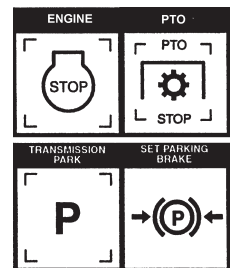

# SAFETY

**DANGER!**



Never allow children or other persons to ride on the Tractor or Implement. Falling off can result in serious injury or death.

\*\*\*\*\*UI /32+



**DANGER!**



Never allow children to operate or ride on the Tractor or Implement.

\*\*\*\*\*UI /33+



**WARNING!**



Do not mount the Tractor while the tractor is moving. Mount the Tractor only when the Tractor and all moving parts are completely stopped.

34+

\*\*\*\*\*UI /



**DANGER!**



Start tractor only when properly seated in the Tractor seat. Starting a tractor in gear can result in injury or death. Read the Tractor operators manual for proper starting instructions. \*UI /35+



**DANGER!**



Never work under the Implement, the framework, or any lifted component unless the Implement is securely supported or blocked up to prevent sudden or inadvertent falling which could cause serious injury or even death. \*\*\*\*UI /36+



**DANGER!**



Do not operate this Equipment with hydraulic oil leaking. Oil is expensive and its presence could present a hazard. Do not check for leaks with your hand! Use a piece of heavy paper or cardboard. High-pressure oil streams from breaks in the line could penetrate the skin and cause tissue damage including gangrene. If oil does penetrate the skin, have the injury treated immediately by a physician knowledgeable and skilled in this procedure. \*\*\*UI /37+



# SAFETY

## WARNING!



The operator and all support personnel should wear hard hats, safety shoes, safety glasses, and proper hearing protection at all times for protection from injury including injury from items thrown by the equipment. \*UI /38+

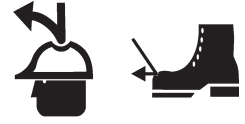

## CAUTION!



**PROLONGED EXPOSURE TO LOUD NOISE MAY CAUSE PERMANENT HEARING LOSS!** Tractors with or without an Implement attached can often be noisy enough to cause permanent hearing loss. We recommend that you always wear hearing protection if the noise in the Operator's position exceeds 80db. Noise over 85db over an extended period of time will cause severe hearing loss. Noise over 90db adjacent to the Operator over an extended period of time will cause permanent or total hearing loss. *Note:* Hearing loss from loud noise [from tractors, chain saws, radios, and other such sources close to the ear] is cumulative over a lifetime without hope of natural recovery. \*UI /19+



## WARNING!



Transport only at safe speeds. Serious accidents and injuries can result from operating this equipment at unsafe speeds. Understand the Tractor and Implement and how it handles before transporting on streets and highways. Make sure the Tractor steering and brakes are in good condition and operate properly.



**Before transporting the Tractor and Implement, determine the safe transport speeds for you and the equipment. Make sure you abide by the following rules:**

1. Test the tractor at a slow speed and increase the speed slowly. Apply the Brakes smoothly to determine the stopping characteristics of the Tractor and Implement. As you increase the speed of the Tractor the stopping distance increases. Determine the maximum safe transport speed for you and this Equipment.
2. Test the equipment at a slow speed in turns. Increase the speed through the turn only after you determine that it is safe to operate at a higher speed. Use extreme care and reduce your speed when turning sharply to prevent the tractor and implement from turning over. Determine the maximum safe turning speed for you and this equipment before operating on roads or uneven ground.
3. Only transport the Tractor and Implement at the speeds that you have determined are safe and which allow you to properly control the equipment.

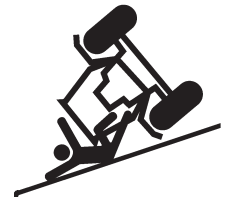

**Be aware of the operating conditions. Do not operate the Tractor with weak or faulty brakes. When operating down a hill or on wet or rain slick roads, the braking distance increases: use extreme care and reduce your speed. When operating in traffic always use the Tractor's flashing warning lights and reduce your speed. Be aware of traffic around you and watch out for the other guy.** (SG-19)

# SAFETY

**WARNING!**



Never attempt to lubricate, adjust, or remove material from the Implement while it is in motion or while tractor engine is running. Make sure the tractor engine is off before working on the Implement.

\*\*\*\*\*UI /42+

**WARNING!**



Periodically inspect all moving parts for wear and replace when necessary with authorized service parts. Look for loose fasteners, worn or broken parts, and leaky or loose fittings. Make sure all pins are properly secured. Serious injury may occur from not maintaining this machine in good working order. \*UI /43+



**WARNING!**



Always read carefully and comply fully with the manufacturers instructions when handling oil, solvents, cleansers, and any other chemical agent. \*UI /44+



**DANGER!**



Never run the tractor engine in a closed building or without adequate ventilation. The exhaust fumes can be hazardous to your health.

\*UI /45+

**DANGER!**



KEEP AWAY FROM ROTATING ELEMENTS to prevent entanglement and possible serious injury or death.

\*\*\*\*\*UI /46+



**DANGER!**



Never allow children to play on or around Tractor or Implement. Children can slip or fall off the Equipment and be injured or killed. Children can cause the Implement to shift or fall crushing themselves or others. \*UI /47+

# SAFETY

## DANGER!



**NEVER use drugs or alcohol** immediately before or while operating the Tractor and Implement. Drugs and alcohol will affect an operator's alertness and coordination and therefore affect the operator's ability to operate the equipment safely. Before operating the Tractor or Implement, an operator on prescription or over-the-counter medication must consult a medical professional regarding any side effects of the medication that would hinder their ability to operate the Equipment safely. **NEVER** knowingly allow anyone to operate this equipment when their alertness or coordination is impaired. Serious injury or death to the operator or others could result if the operator is under the influence of drugs or alcohol. \*UI /49+



## DANGER!



Operate the Tractor and/or Implement controls only while properly seated in the Tractor seat with the seat belt securely fastened around you. Inadvertent movement of the Tractor or Implement may cause serious injury or death. \*UI /4; +

## WARNING!



Mow only in conditions where you have clear visibility in daylight or with adequate artificial lighting. Never mow in darkness or foggy conditions where you cannot clearly see at least 100 yards in front and to the sides of the tractor and mower. Make sure that you can clearly see and identify passersby, steep slopes, ditches, drop-offs, overhead obstructions, power lines, debris and foreign objects. If you are unable to clearly see this type of items discontinue mowing. \*UI 0/3+

## DANGER!



There are obvious and hidden potential hazards in the operation of this Mower. **REMEMBER!** This machine is often operated in heavy brush and in heavy weeds. The Blades of this Mower can throw objects if shields are not properly installed and maintained. Serious injury or even death may occur unless care is taken to insure the safety of the operator, bystanders, or passersby in the area. Do not operate this machine with anyone in the immediate area. Stop mowing if anyone is within 100 yards of mower. \*UI 0/4+



## DANGER!



All Safety Shields, Guards and Safety devices including (but not limited to) - the Deflectors, Chain Guards, Steel Guards, Gearbox Shields, PTO integral shields, and Retractable Door Shields should be used and maintained in good working condition. All safety devices should be inspected carefully at least daily for missing or broken components. Missing, broken, or worn items must be replaced at once to reduce the possibility of injury or death from thrown objects, entanglement, or blade contact. \*UI 0/5+

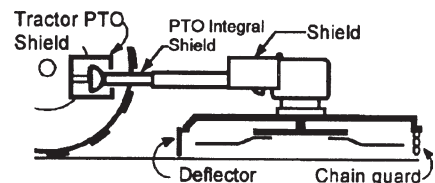

# SAFETY

## DANGER!



The rotating parts of this machine have been designed and tested for rugged use. However, the blades could fail upon impact with heavy, solid objects such as metal guard rails and concrete structures. Such impact could cause the broken objects to be thrown outward at very high velocities. To reduce the possibility of property damage, serious injury, or even death, never allow the cutting blades to contact such obstacles. \*UI O/6+

## WARNING!



Extreme care should be taken when operating near loose objects such as gravel, rocks, wire, and other debris. Inspect the area before mowing. Foreign objects should be removed from the site to prevent machine damage and/or bodily injury or even death. Any objects that cannot be removed must be clearly marked and carefully avoided by the operator. Stop mowing immediately if blades strike a foreign object. Repair all damage and make certain rotor or blade carrier is balanced before resuming mowing. \*UI O/7+



## WARNING!



Many varied objects, such as wire, cable, rope, or chains, can become entangled in the operating parts of the mower head. These items could then swing outside the housing at greater velocities than the blades. Such a situation is extremely hazardous and could result in serious injury or even death. Inspect the cutting area for such objects before mowing. Remove any like object from the site. Never allow the cutting blades to contact such items. \*\*UI O/8+

## WARNING!



Mow at the speed that you can safely operate and control the tractor and mower. Safe mowing speed depends on terrain condition and grass type, density, and height of cut. Normal ground speed range is from 0 to 5 mph. Use slow mowing speeds when operating on or near steep slopes, ditches, drop-offs, overhead obstructions, power lines, or when debris and foreign objects are to be avoided. \*UI O/9+

## WARNING!



Avoid mowing in reverse direction when possible. Check to make sure there are no persons behind the mower and use extreme care when mowing in reverse. Mow only at a slow ground speed where you can safely operate and control the tractor and mower. Never mow an area that you have not inspected and removed debris or foreign material. \*\*\*UI O/; +

## WARNING!



Do not put hands or feet under mower decks. Blade Contact can result serious injury or even death. Stay away until all motion has stopped and the decks are securely blocked up. \*UI O/; +



## DANGER!



Replace bent or broken blade with new blades. NEVER ATTEMPT TO STRAIGHTEN OR WELD ON BLADES SINCE THIS WILL LIKELY CRACK OR OTHERWISE DAMAGE THE BLADE WITH SUBSEQUENT FAILURE AND POSSIBLE SERIOUS INJURY FROM THROWN BLADES. \*\*\*\*UI O/32+

# SAFETY

## WARNING!



Do not mow with two machines in the same area except with Cab tractors with the windows closed. \*U O/33+

## DANGER!



Rotary and Flail Mowers are capable under adverse conditions of throwing objects for great distances (100 yards or more) and causing serious injury or death. Follow safety messages carefully. **STOP MOWING IF PASSERSBY ARE WITHIN 100 YARDS UNLESS:**

- Front and Rear Deflectors are installed and in good, working condition;
- Mower Head is running close to and parallel to the ground without exposed Blades;
- Passersby are outside the existing thrown-object zone;
- All areas have been thoroughly inspected and all foreign material such as rocks, cans, glass, and general debris has been removed.



**NOTE:** Where there are grass and weeds high enough to hide debris that could be struck by the blades, the area should be: inspected and large debris removed, mowed at an intermediate height, inspected closely with any remaining debris being removed, and mowed again at desired final height. \*UDO/3+



## DANGER!



Use extreme caution when raising the Mower head. Stop the Blades from turning when the Mower Head is raised and passersby are within 100 yards. Raising the Mower head exposes the Cutting Blades which creates a potentially serious hazard and can cause serious injury by objects thrown from the Blades or by contact with the Blades. \*\*\*\*\*UDO/4+

## DANGER!



Be particularly careful in transport. The Mower has raised the center of gravity for the tractor and has increased the possibility of overturn. Turn curves or go up slopes only at low speed and using a gradual turning angle. Slow down on rough or uneven surfaces. \*UDO/5+



## WARNING!



Never Leave the mower unattended while the head is in the raised position. The mower could fall causing serious injury to anyone who might inadvertently be under the mower. \*\*\*\*\*UDO/6+



## WARNING!



The rotating parts of this machine continue to rotate even after the Tractor has been turned off. The operator should remain in his seat for 60 seconds after the brake has been set, the PTO disengaged, the tractor turned off, and all evidence of rotation has ceased. \*UDO/7+

**“Wait a minute...Save a life!”**

# SAFETY



Relieve hydraulic pressure prior to doing any maintenance or repair work on the Implement. Place the Mower Head on the ground or securely supported on blocks or stands, disengage the PTO, and turn off the engine. Push and pull the control Levers or Joystick several times to relieve pressure prior to starting any maintenance or repair work. \*UDO /8+

**DANGER!**



Always keep a careful lookout and use extreme care when working around overhead obstructions. Never allow the Mower head or boom within 10 feet of any power line. When working close to overhead power lines consult your electric company for a safe code of operation. \*UDO /9+

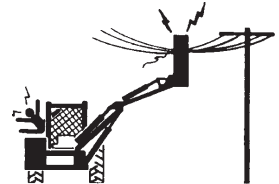

**DANGER!**



When transporting Boom Mower on a truck or trailer, the height or width may exceed legal limits when the boom is in the transport position. Contact with side or overhead structures or power lines can cause property damage or serious injury or death. If necessary lower boom to reduce height and/or remove mowing head to reduce width to the legal limits. \*UDO /; +

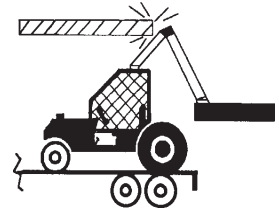

**DANGER!**



Never operate the Tractor and Mower Unit without an OPS (Operators Protective Structure) or Cab to prevent injury from objects thrown from ground or from overhead trimming. Stop mowing if workers or passersby are within 100 yards. \*UDO /; +



**DANGER!**



Each Rear Wheel must have a minimum of 1500 pound contact with the surface to prevent lateral instability and possible tip-over which could result in serious bodily injury or even death. Widen the wheel tread and add weights if needed. Refer to the mounting instructions or call Customer Service if you need assistance with Counterweight Procedure. \*UDO /33+



**DANGER!**



Always disconnect the wire leads from the mower pump solenoid before performing service on the Tractor or Mower. Use caution when working on the Tractor or Mower. Tractor engine must be stopped before working on Mower or Tractor. The Mower Blades could inadvertently be turned on without warning and cause immediate dismemberment, injury or death. \*\*\*UDO /34c+

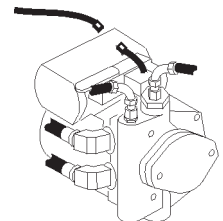

**DANGER!**



The flail cutter shaft is designed for standard rotation (same rotation as the tractor wheels during forward travel). **Never operate the cutter shaft in the reverse rotation.** Operating this mower in reverse rotation may cause objects to be thrown out the front of the mower head.

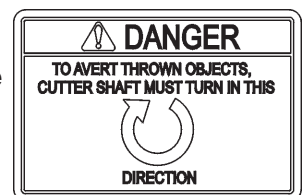



# SAFETY

## WARNING!



Engine Exhaust, some of its constituents, and certain components contain or emit chemicals known to the state of California to cause cancer and birth or other reproductive harm.

## WARNING!



Battery posts, terminals and related accessories contain lead and lead compounds, chemicals known to the state of California to cause cancer and birth or other reproductive harm. **Wash hands after handling!**

Tiger mowers use balanced and matched system components for blade carriers, blades, cutter-shafts, knives, knife hangers, rollers, drive-train components and bearings. These parts are made and tested to Tiger specifications. Non-genuine “will fit” parts do not consistently meet these specifications. The use of “will fit” parts may reduce mower performance, void mower warranties and present a safety hazard. Use genuine Tiger mower parts for economy and safety.

SEE YOUR  DEALER

**In addition to the design and configuration of this Implement, including Safety Signs and Safety Equipment, hazard control and accident prevention are dependent upon the awareness, concern, prudence, and proper training of personnel involved in the operation, transport, maintenance, and storage of the machine. Refer also to Safety Messages and operation instruction in each of the appropriate sections of the Tractor and Equipment Manuals. Pay close attention to the Safety Signs affixed to the Tractor and Equipment.** (SG-18)

# SAFETY

## **DANGER**

FAILING TO FOLLOW SAFETY MESSAGES AND OPERATING INSTRUCTIONS CAN CAUSE SERIOUS BODILY INJURY OR EVEN DEATH TO OPERATOR AND OTHERS IN THE AREA.



1. Study and understand Operator's Manuals, Safety Signs, and Instructional Decals for tractor & flail mower to prevent misuse, abuse, & accidents. Practice before operating mower in a confined area or near passersby.
  - Learn how to stop engine suddenly in an emergency. Be alert for passersby and especially children.
2. Allow no children on or near implement or tractor. Allow no riders on tractor or implement. Falling off can cause serious injury or death from being runover by tractor or mower or contact with Flail Mower Blades.
3. Operate only with tractor having Roll-Over Protective Structure (ROPS) and with seatbelt fastened securely and snugly to prevent injury and possible death from falling off or tractor overturn. Personal Protective Equipment such as Hard Hat, Safety Glasses, Safety Shoes, and Ear Plugs are recommended.
4. Block up or support raised machine and all lifted components securely before putting hands or feet under or working underneath any lifted component to prevent crushing injury or death from sudden dropping or inadvertent operation of controls. Make certain that area is clear before lowering or folding.
5. Before transporting, put Lift Lever in detent or full-lift position. Install Transport Safety Devices securely on folding implements. Slow down when turning and on hillsides.
  - Install \*\*Restrictor in folding circuit to slow down lowering and unfolding if action is faster than is desirable.
6. Make certain that SMV sign, Warning Lights, and Reflectors are clearly visible. Follow local traffic codes.
7. Never operate with Flail Mower or Folding Section raised if passersby, bystanders or traffic are in the area to reduce possibility of injury or death from objects thrown by Blades under Shields or implement structure.
8. Before dismounting, secure flail mower in transport position or lower to ground.
  - Put tractor in park or set brake, disengage PTO, stop engine, remove key, and wait until noise of rotation has ceased to prevent entanglement in rotating parts which may cause injury or death.
  - Never mount or dismount a moving vehicle. Crushing from runover may cause injury or death.

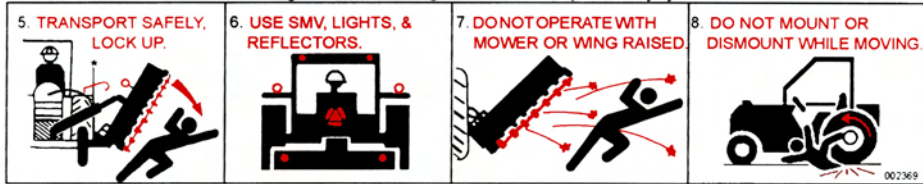

PART NO.  
LOCATION

002369  
HYDRAULIC TANK

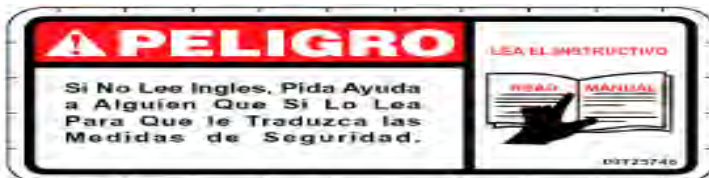

00725746  
INSIDE OF CAB

## **DANGER**

THROWN OBJECTS

CUTTING BLADES



**KEEP AWAY - ROTATING BLADES**

BEING HIT BY THROWN OBJECTS OR CONTACTING ROTATING BLADES CAN CAUSE INJURY OR DEATH.

- Stop mowing if passersby enter the area of thrown objects (See Operator's Manual).
- Use special care if Mower Head or Wing is raised off the ground. (See Manual).
- Operate only if all Guards-Deflectors are in place and in good condition.

00769737

00769737  
MOWER DECK

# SAFETY



PART NO.  
LOCATION

00758194  
MOWER DECK



02962764  
MAIN BOOM, SECONDARY BOOM, MAIN FRAME



02962765  
MAIN FRAME

02965262  
HYDRAULIC TANK

# SAFETY

## **DANGER**

CUTTING BLADES



THROWN OBJECTS



### **KEEP AWAY - ROTATING BLADES**

**BEING HIT BY THROWN OBJECTS OR CONTACTING ROTATING BLADES CAN CAUSE INJURY OR DEATH**

- Stop mowing if passersby enter the area of thrown objects. (See Operator's Manual)
- Use special care when Flail or Wing is raised off the ground. (See Oper. Manual)
- Operate only if all Guards-Deflectors are in place and in good condition.

PART NO.  
LOCATION

02967668  
MOWER DECK

02971123  
HYDRAULIC TANK

03200285  
OUTSIDE OF CAB

22645  
INSIDE OF CAB

22839  
MOWER DECK

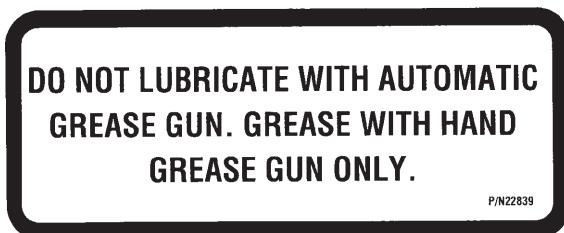
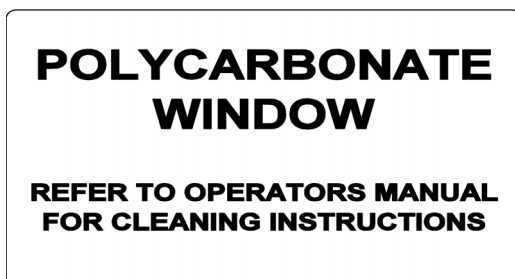

# SAFETY



PART NO.  
LOCATION

22840  
INSIDE OF CAB



24028  
MOWER DECK

25387  
INSIDE OF CAB



10" x 5.5" 31522  
MOWER DECK, MAIN BOOM  
18.25" x 10" 31523  
HYDRAULIC TANK  
13.5" x 7" 31513

# SAFETY

**WARNING**

Valve section TF3009 with detented float to be used with only Boom Flail mower. DO NOT operate a Boom rotary mower with the float section installed.

P/N 27001

PART NO.  
LOCATION

27001  
INSIDE OF CAB

**LOCK**

↑

**TRAVEL LOCK**

↓

**UNLOCK**

31935

31935  
INSIDE OF CAB

**DANGER**

- EACH REAR WHEEL MUST HAVE A MINIMUM OF 1500 POUNDS CONTACT WITH THE SURFACE TO PREVENT LATERAL INSTABILITY AND POSSIBLE TIP-OVER WITH BODILY INJURY. WIDEN WHEEL TREAD AND ADD WEIGHTS IF NEEDED. SEE MANUAL OR CALL TIGER CUSTOMER SERVICE FOR COUNTERWEIGHT PROCEDURE.
- TRANSPORT CAREFULLY! SLOW DOWN EVEN MORE ON SLOPES AND WHEN TURNING; NEVER TURN UP A SLOPE SHARPLY OR AT HIGH SPEED; AND USE EXTRA CARE IN ROUGH OR BUMPY AREAS TO PREVENT OVERTURN AND POSSIBLE CRUSHING INJURY OR DEATH. IF YOUR VIEW TO THE REAR IS BLOCKED, IT IS YOUR RESPONSIBILITY TO INSTALL MIRRORS THAT PROVIDE A REAR VIEW TO PREVENT ACCIDENTS FROM BLIND SPOTS.
- REAR-MOUNTED BOOM MOWERS MOVE CENTER OF GRAVITY TO THE REAR AND REMOVE WEIGHT FROM FRONT WHEELS. ADD FRONT BALLAST UNTIL AT LEAST 20% OF TRACTOR'S WEIGHT IS ON FRONT WHEELS TO PREVENT REARING UP, LOSS OF STEERING CONTROL, AND POSSIBLE INJURY.
- NEVER OPERATE UNIT WITHOUT AN OPS (OPERATOR PROTECTIVE STRUCTURE) OR CAB TO PREVENT INJURY FROM OBJECTS THROWN FROM GROUND AND OVERHEAD TRIMMING. STOP CUTTING IF ANYONE IS WITHIN 100 YARDS.
- KEEP THE BOOM AND CUTTERHEAD AT LEAST 10 FEET FROM ELECTRIC LINES AND PIPE LINES TO PREVENT ACCIDENTAL CONTACT AND POSSIBLE SERIOUS INJURY OR EVEN DEATH.
- WHEN TRANSPORTING BOOM MOWERS ON A TRUCK OR TRAILER, THE HEIGHT OR WIDTH MAY EXCEED LEGAL LIMITS. CONTACT WITH SIDE OR OVERHEAD STRUCTURES OR POWER LINES CAN CAUSE SERIOUS INJURY OR DEATH. LOWER BOOM TO REDUCE HEIGHT AND/OR REMOVE MOWING HEAD TO REDUCE WIDTH TO THE LEGAL LIMITS, IF NEEDED.

32707

32707  
HYDRAULIC TANK

**DANGER**

TO AVERT THROWN OBJECTS,  
CUTTER SHAFT MUST TURN IN THIS

↻

**DIRECTION**

42350

42350  
MOWER DECK

# SAFETY

## ATTENTION

**SERVICE HYDRAULIC SYSTEM  
WITH UNIVERSAL TRACTOR  
HYDRAULIC OIL.**

32708

PART NO.  
LOCATION

32708  
HYDRAULIC TANK

## CAUTION

For your safety and to guarantee optimum product reliability, always use genuine TIGER replacement parts. The use of inferior "will-fit" parts will void warranty of your TIGER implement and may cause premature or catastrophic failure which can result in serious injury or death. If you have any questions concerning the repair parts you are using, contact TIGER, 3301 N. LOUISE AVE., SIOUX FALLS, SD 57107

32709

32709  
INSIDE OF CAB

33224  
MOWER DECK

# Tiger™

33438  
MAIN BOOM

# SAFETY

PART NO.  
LOCATION

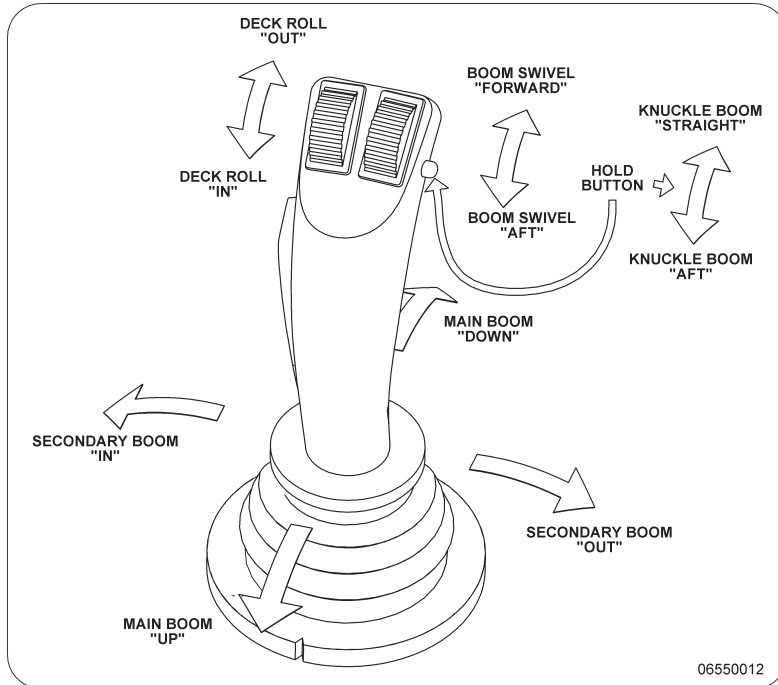

06550012  
INSIDE OF CAB

## MOWING SAFETY TIPS

- 1 Read & understand the Operators Manual.
- 2 Wear Your Seat Belt.
- 3 Keep all shields and guards in place.
- 4 Make sure equipment is in proper working condition.
- 5 Never attempt to get off or on a moving tractor.
- 6 Never allow riders on tractor or equipment.
- 7 Only start the tractor from the seat with the key.
- 8 Always inspect the area before mowing. Remove all foreign debris.
- 9 Always keep bystanders and coworkers a minimum of 300 feet away.
- 10 Never allow the mower blades to contact solid objects or foreign material.
- 11 Never approach rotating elements.
- 12 Disengage the PTO, place transmission in "Park", set parking brake, shut off engine, and remove key and wait until all rotating motion has stopped before leaving seat.

**Tiger**

33743

33743  
INSIDE OF CAB



# SAFETY

PART NO.  
LOCATION



RED 42399  
REFLECTIVE TAPE  
MOWER DECK

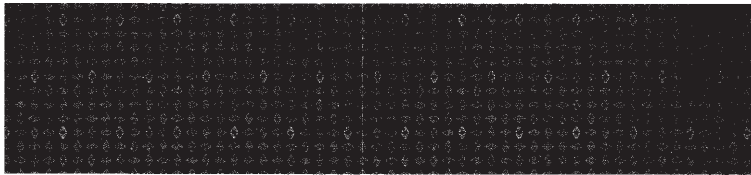

AMBER 424006  
REFLECTIVE TAPE  
MOWER DECK



6T3217  
MOWER DECK



6T3219  
INSIDE OF CAB

6T3220  
FRONT PUMP MOUNT

# SAFETY

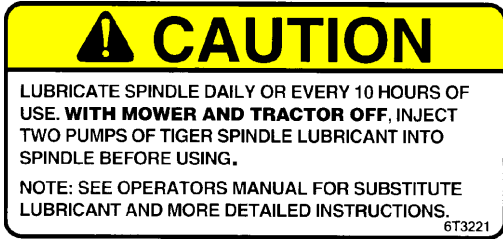

PART NO.  
LOCATION

6T3221  
INSIDE OF CAB

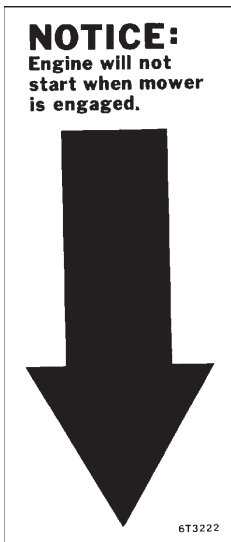

6T3222  
INSIDE OF CAB



6T3224  
MOWER DECK

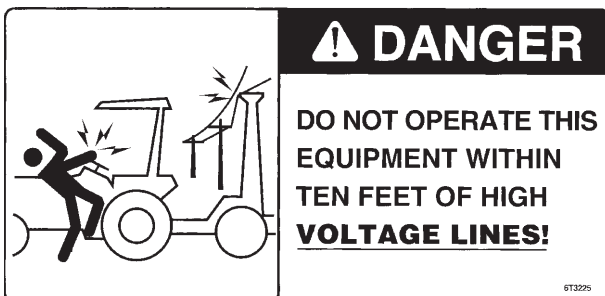

6T3225  
INSIDE OF CAB

# SAFETY

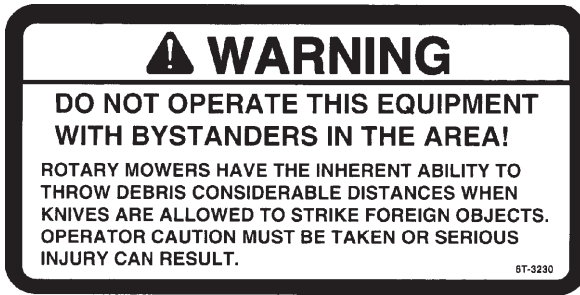

PART NO.  
LOCATION

6T3230  
INSIDE OF CAB



6T3231  
INSIDE OF CAB



6T3233  
HYDRAULIC TANK



6T3234  
INSIDE OF CAB



6T3236  
MOWER DECK

# SAFETY

**⚠ WARNING**

---

WHEN CUTTING HEAVY BRUSH,  
BLADE BOLTS SHOULD BE  
INSPECTED HOURLY AND  
RETORQUED TO 600 FT. LBS.

6T-3237

6T3237

PART NO.  
LOCATION  
6T3237  
INSIDE OF CAB

<p>DOWN ↑ <b>MAIN BOOM</b> ↓ UP</p>	<p>OUT ↑ <b>SECONDARY BOOM</b> ↓ IN</p>	<p>OUT ↑ <b>DECK ROLL</b> ↓ IN</p>	<p>CLOSE ↑ <b>SHIELD</b> ↓ OPEN</p>	<p>FORWARD ↑ <b>SWIVEL</b> ↓ AFT</p>	<p>IN ↑ <b>SWITCH / KNUCKLE</b> ↓ OUT</p>
---	---	--	---	--	---

06550008  
INSIDE OF CAB

<p style="text-align: center;"><b>⚠ WARNING</b></p> <p style="font-size: x-small;">IT IS RECOMMENDED THAT THE BOLT AND LOCK NUT BE REPLACED WHENEVER BLADES ARE REPLACED. REPLACE THESE ANY TIME THEY ARE DAMAGED OR WORN AS FAILURE TO DO SO CAN LEAD TO BLADES COMING OFF CAUSING SERIOUS INJURY OR DEATH.</p>	<p style="text-align: center;"><b>IMPORTANT</b></p> <ul style="list-style-type: none"> <li>• WHEN REPLACING BLADES, IT IS RECOMMENDED THAT ALL BLADES BE REPLACED FOR PROPER BALANCE TO AVOID EXCESSIVE VIBRATIONS WHICH CAN DAMAGE SPINDLE ASSEMBLY.</li> <li>• SEE YOUR OPERATOR'S MANUAL FOR PROPER INSTALLATION INSTRUCTIONS.</li> </ul> <p style="text-align: right; font-size: x-small;">6T-3243</p>
--	--

6T3243  
INSIDE OF CAB

**GREASING INSTRUCTIONS**

**CUTTER SHAFT BEARING**

GREASE EVERY 8 HRS. OR DAILY

NOTE: If unusual environmental conditions exist-extreme temperatures, moisture, or contaminants-more frequent lubrication is required.

6T3249A

6T3249A  
MOWER DECK

**GREASING INSTRUCTIONS**

**GROUND ROLLER BEARING**

GREASE EVERY 8 HRS. OR DAILY

NOTE: If unusual environmental conditions exist-extreme temperatures, moisture, or contaminants-more frequent lubrication is required.

6T3261

6T3261  
MOWER DECK

# SAFETY



## WARNING

**DO NOT OPERATE MOWER  
WITH SAFETY SHIELD REMOVED.**

TB1011

TB1011  
MOWER DECK



**Tiger Corporation**

800-843-6849  
www.tiger-mowers.com

Description	Application	General Specification	Recommended Lubricant
Tractor Hydraulics	Reservoir	JD-20C	Mobilfluid® 424
Mower Hydraulics	Reservoir	ISO 46 Anti-Wear/ Low Temp	Mobil DTE® 15M
Cold Temperatures 0°F Start-up		JD-20C	Mobilfluid® 424
Normal Temperatures 10°F Start-up		ISO 46 Anti-Wear	Mobil DTE® 25
Normal Temperatures 15°F Start-up		ISO 100 Anti-Wear	Mobil DTE® 18M
High Operating Temperatures Above 90°F Ambient			
Flail Rear Gearbox	Reservoir	PAO Synthetic Extreme Pressure Gear Lube	Mobilube SHC® 75W-90, Mobil 1 Synthetic Gear Lubricant
Cutter Shaft and Ground Roller Shaft (Flail)	Grease Gun	Lithium Complex, NLGI 2 ISO 320	Mobilgrease® CM-S
Drive Shaft Coupler (Rotary and Flail) Drive Shaft Yoke, U - Joint and Stub Shaft	Grease Gun	Lithium Complex, NLGI 2 ISO 320	Mobilgrease® CM-S
Boom Swivel, Boom Cylinder Pivots (Rotary and Flail Boom Type)	Grease Gun	Lithium Complex, NLGI 2 ISO 320	Mobilgrease® CM-S
Deck Boom Pivot & Deck Stop Adjustment (Rotary and Flail)	Grease Gun	Lithium Complex, NLGI 2 ISO 320	Mobilgrease® CM-S
Deck Spindle (Rotary)	Grease Gun	Tiger Spindle Lubricant	Tiger Part #25351

**For Mobil product information, availability, or technical information, call 1-800-662-4525.**

Tiger PN 34852

34852  
HYDRAULIC TANK

# SAFETY



ITEM	PART NO.	QTY.	DESCRIPTION
	<b>50023</b>	<b>AVAIL</b>	<b>MANUAL CANISTER COMPLETE</b>
1	00776031	1	ROUND MANUAL CANISTER
	33997	1	DECAL, SHEET, MANUAL CANISTER
2		*	DECAL
3		*	DECAL
4		*	DECAL
5	*	AVAIL	SPECIFIC PRODUCT MANUAL
6	33753	1	E M I SAFETY MANUAL
7	34296	1	FRONT ADHESIVE PAD
8	34297	1	REAR ADHESIVE PAD
9	6T1823	4	ZIP TIE 14" LONG

**NOTE:**

The manual canister can be bolted, zip tied or adhered to a variety of surfaces. Locate a protected area within the view of the operator. Then select an installation method and attach the canister. **CAUTION - AVOID DRILLING HOLES INTO UNKNOWN AREAS**, wires and other parts may be located behind these areas. When adhering the canister to a surface, thoroughly clean that surface before installing the canister.

# SAFETY

## FEDERAL LAWS AND REGULATIONS

This section is intended to explain in broad terms the concept and effect of federal laws and regulations concerning employer and employee equipment operators. This section is not intended as a legal interpretation of the law and should not be considered as such.

### Employer-Employee Operator Regulations

U.S. Public Law 91-596 (The Williams-Steiger Occupational and Health Act of 1970) OSHA

#### This Act Seeks:

“...to assure so far as possible every working man and woman in the nation safe and healthful working conditions and to preserve our human resources...”

#### DUTIES

Sec. 5 (a) Each employer-

(1) shall furnish to each of his employees employment and a place of employment which are free from recognized hazards that are causing or are likely to cause death or serious physical harm to his employees;

(2) shall comply with occupational safety and health standards promulgated under this Act.

(b) Each employee shall comply with occupational safety and health standards and all rules, regulations and orders issued pursuant to this Act which are applicable to his own actions and conduct.

#### OSHA Regulations

OSHA regulations state in part: “At the time of initial assignment and at least annually thereafter, the employer shall instruct every employee in the safe operation and servicing of all equipment with which the employee is, or will be involved.”

#### Employer Responsibilities:

To ensure employee safety during Tractor and Implement operation, it is the employer’s responsibility to:

1. Train the employee in the proper and safe operation of the Tractor and Implement.
2. Require that the employee read and fully understand the Tractor and Implement Operator’s manual.
3. Permit only qualified and properly trained employees to operate the Tractor and Implement.
4. Maintain the Tractor and Implement in a safe operational condition and maintain all shields and guards on the equipment.
5. Ensure the Tractor is equipped with a functional ROPS and seat belt and require that the employee operator securely fasten the safety belt and operate with the ROPS in the raised position at all times.
6. Forbid the employee operator to carry additional riders on the Tractor or Implement.
7. Provide the required tools to maintain the Tractor and Implement in a good safe working condition and provide the necessary support devices to secure the equipment safely while performing repairs and service.

#### Child Labor Under 16 Years of Age

Some regulations specify that no one under the age of 16 may operate power machinery. It is your responsibility to know what these regulations are in your own area or situation. (Refer to U.S. Dept. of Labor, Employment Standard Administration, Wage & Home Division, Child Labor Bulletin #102.)

# SAFETY



# **ASSEMBLY SECTION**

# ASSEMBLY

**Before attempting to mount your Tiger mower, it is important to read and understand all of the Safety Messages in the Safety section of this manual.**

Check complete shipment list against the packing list to make sure there are no shortages. Make certain the tractor model is the appropriate one for the mower received!



Always use a floor jack, hoist or fork lift to lift and raise heavy parts.

Read and understand the entire assembly section instructions before attempting to mount your Tiger mower. Refer to the parts section of this manual for detailed illustrations to locate all parts. (ASM-C-0001)

## TRACTOR PREPARATION

- A. Remove right and left hand steps.
- B. Disconnect battery cables from both batteries.
- C. Remove engine side panels, or raise hood to access front pulley.
- D. Remove plugs from tractor casting where main frame and pump mount will be attached.
- E. Remove any front weights and weight supports.
- F. Raise the tractor onto jack-stands and remove the right and left rear wheels.

(ASM-JD-0001)

## CRANKSHAFT ADAPTER

If necessary remove the four capscrews from the crankshaft pulley. Then install the crankshaft adapter to the pulley with capscrews and lockwashers as shown in the parts section.

(ASM-JD-0051)

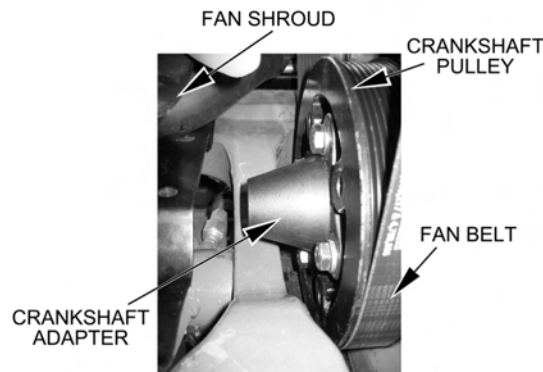

# ASSEMBLY

## DRIVESHAFT & FRONT PUMP MOUNTING

Install the pump mounting bracket on the front of the tractor with capscrews and washers as shown in the parts section illustration. **DO NOT** tighten fasteners at this time.

Slide the pump drive shaft into the crankshaft adapter. The end with the shorter splines should be inserted into the adapter (if applicable).

Slide the splined drive shaft coupler onto the pump drive shaft. Install the pump onto the mounting bracket. **NOTE:** the shaft is offset to one direction, the pump should be installed with the offset side on top. Install hardware for securing pump to the pump mount, **DO NOT** tighten.

Align pump so that splined coupling can be moved back and forth by hand. Tighten pump mounting bolts in succession rechecking for spline coupling movement. Remove the pump mounting bracket bolts one at a time and apply a tj read locking agent. Tighten these bolts in succession, again checking for free movement in the drive shaft. After all bolts are torqued, the end play on the drive shaft should be 1/16" to 1/8", and coupler should move freely with hand pressure. If end play is less than 1/16", grind the end of the shaft to achieve the proper end play. If there is more than 1/4" of end play, return the shaft with specifications for a longer shaft.

**CAUTION: DO NOT START THE TRACTOR UNTIL ALL HOSES ARE ATTACHED, TANK IS FILLED WITH PROPER OIL AND BALL VALVES ARE OPEN! STARTING AT THIS TIME WILL CAUSE SERIOUS DAMAGE TO THE PUMP.** (ASM-C-0097)

## ADJUSTING REAR WHEELS

Raise rear of tractor onto jack-stands. **Follow the instructions in the tractor owners manual for adjusting tires and rims.** The back wheels **MUST** be adjusted to the widest setting. **NOTE:** This may require switching the wheels to opposite sides of tractor. Also take note of any width restrictions when transporting by trailer. (For ease of installation, it is best to leave the rear wheels removed during installation of the mower.) (ASM-B-0001)



# ASSEMBLY

## REAR FENDER CUT

In order to prevent interference between the right rear fender and the rear stow boomrest, the rear fender will need to be cut. Cut the fender as shown below, 1" deep and approximately 5" long, from the outside, in order to clear the boomrest. (ASM-KUB-0039)

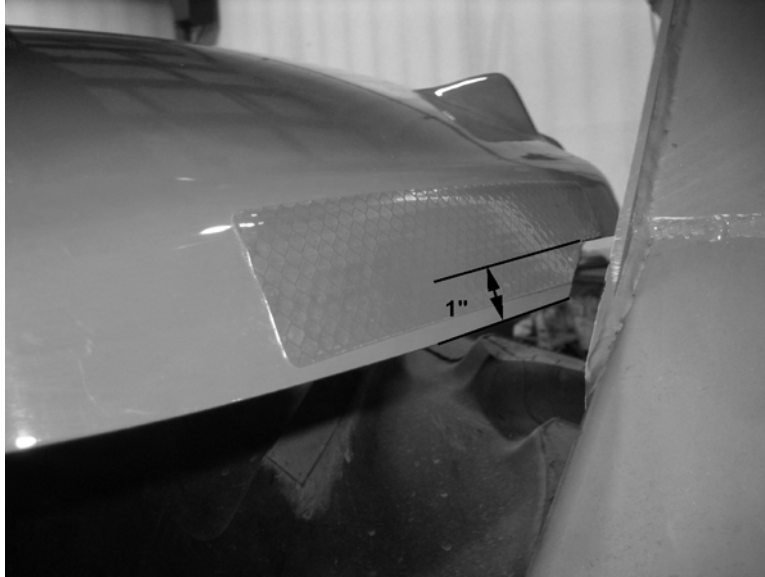

## SIDE MIRROR REMOVAL

In order to prevent damage to the right side mirror, it will have to be removed. The boom will interfere when it is fully raised. Make sure to retain the hardware which may be used to mount the polycarbonate safety window. (ASM-KUB-0040)



# ASSEMBLY

## POLYCARBONATE SAFETY WINDOW

NOTE: Installing a boom mower requires that all of the right side windows be replaced with polycarbonate. Install the safety windows after all of the cab wiring and mounting is done; and before the boom arm is mounted. Locate all the hardware in the Parts Section when installing the polycarbonate.

Remove the right door from the tractor cab. Remove the hardware and check the image below for which parts are re-used. Wrap the trim seal around the polycarbonate and cut the trim to match the other end so a seal will form to the frame. Apply the adhesive in the groove of the trim seal where the polycarbonate sits and apply the trim seal to the polycarbonate. Add the hinges (with existing hardware), door handle (with supplied hardware) and the handrails (with existing hardware) and install the polycarbonate to the tractor frame.

Close the polycarbonate door to the cab. Remove the handrail and install the two handrail brackets between the tractor and the handrail. Reattach the handrail.

Drill a 1/4" hole in the center of the bottom door frame. Attach the bottom bracket as shown in the Parts Section. Use the vibration isolator, threaded rod and hex nuts to push the polycarbonate against the frame.

Remove the mirror hardware and install the mirror bracket on the bottom two holes of the tractor mirror mount with the hardware provided. Use the vibration isolator, threaded rod and hex nuts to push the polycarbonate against the frame.

Locate the existing hole over the fender in the door frame of the cab. Attach the polycarbonate bracket to the fender with the hardware provided. Drill a 5/16" hole through the polycarbonate and secure the window to the mount. To attach the lower rubber washers to the polycarbonate, drill a 5/16" hole through the polycarbonate so the inner washer presses on the door frame and is 1" away from the edge of the door. (ASM-KUB-0033)

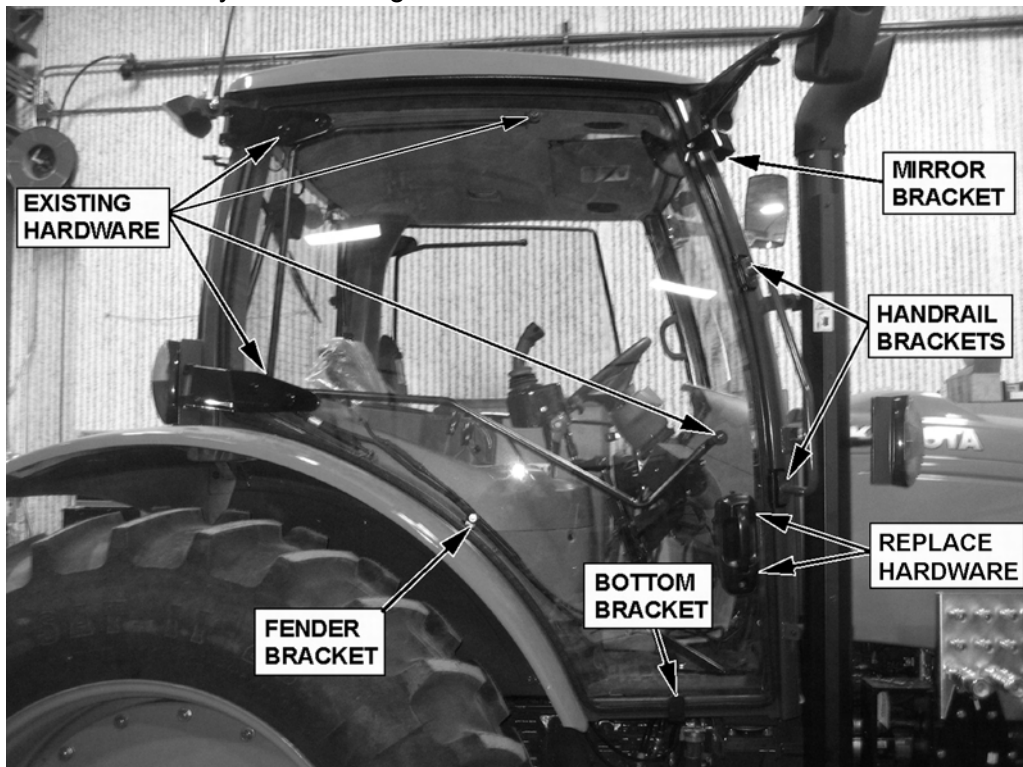

# ASSEMBLY

## MAIN FRAME INSTALLATION

With an overhead hoist and / or jack-stands, raise one side of the frame up to the correctly matching mounting holes. Install capscrews and all other hardware as shown in main frame parts section to secure the sides of the main frame to the tractor casting, DO NOT tighten at this time. Remove the capscrews one at a time and apply a thread locking agent. Reinsert the capscrews and tighten / torque to values noted in the torque chart located in the maintenance section of this manual. (ASM-C-0003)

## WEATHER-PACK/METRI-PACK ASSEMBLY

These instructions apply to both Weather-Pack and Metri-pack connectors.

**NOTE: Use the specific tool for the type of connector you are assembling.**

(ASM-C-0009)

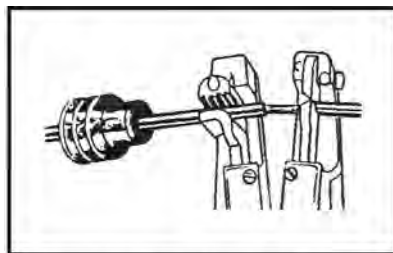

1. Apply seal to cable, before stripping insulation.



2. Align seal with cable insulation.

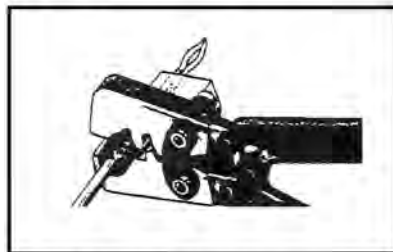

3. Put terminal in crimping tool, then

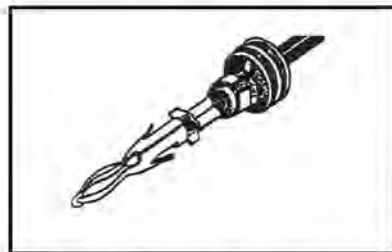

4. Crimp and visually inspect for a good



# ASSEMBLY

## LIFT VALVE LINE INSTALLATION

The Tiger lift valve used needs to access the pressure, return and power beyond ports of the tractor. To access the ports, 1/2" adapters are used.

The return port is located above the PTO. The return hose runs from the return port on the lift valve to the return port on the tractor.

The pressure port is located under the cab and forward from the power beyond port. Route the hose from the pressure port to the lift valve (manual) or priority valve (joystick). Next run the pressure hose from the filter to the pressure port on the lift valve.

The power beyond port is located behind the right rear tire. Install the hose from the power beyond port of the lift valve (manual) or priority valve (joystick) to the power beyond port of the tractor. (ASM-KUB-0038)

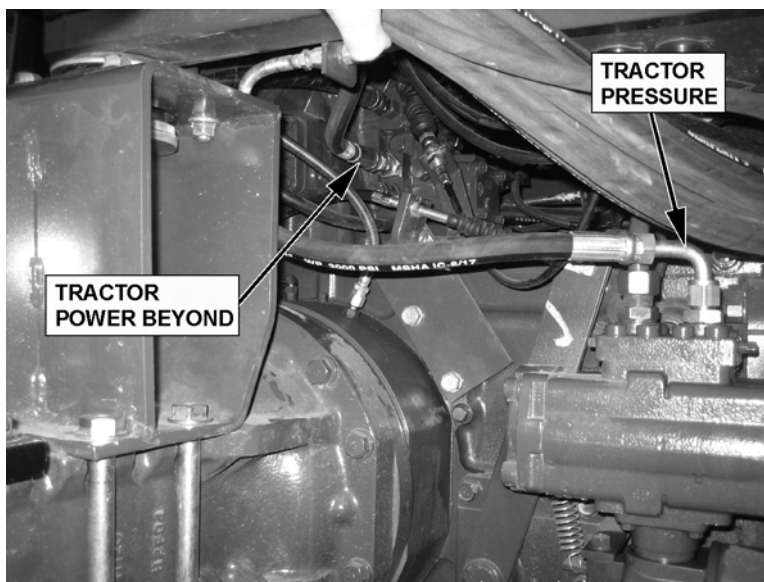
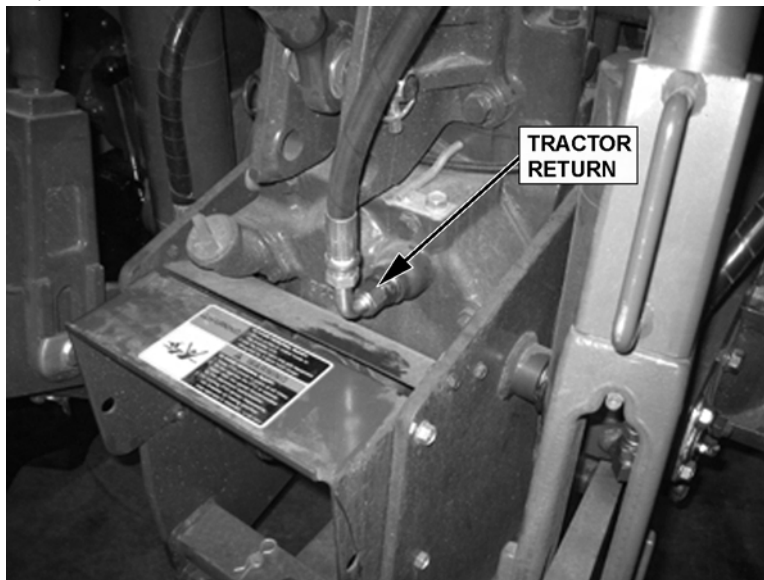

# ASSEMBLY

## CABLE CONTROL MOUNTING BRACKET

Preassemble the cable control mounting as shown in the Parts Section. **Use the image below for positioning the cable control bracket.** Position the support bracket on the floor as a template. The upper left hole of the bracket is 7-1/8" from the edge of the door and 6-3/4" from the corner post as shown below. The front corner of the bracket is 2-3/4" from the edge of the door as shown below. Mark the holes on top of the floor mat. Be sure that the location of the stand will allow clearance between the cable control bracket and all existing interior levers, etc. Also watch out for wiring and brackets when placing the bracket for drilling and cutting. Cut holes in the mat with a 1-1/8" hole saw. The spacers provided are used to allow the control bracket to set on top of the floor mat while being held securely to the floor of the cab. Drill 3 holes for the capscrews using the bracket and spacers as a template. Then secure with the hardware as noted in the Parts Section. (ASM-KUB-0034)

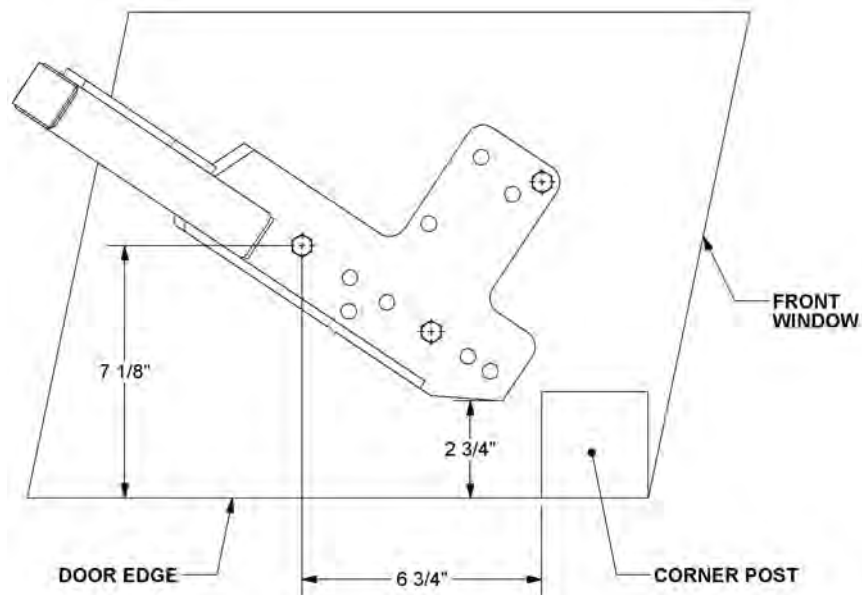



# ASSEMBLY

## SWITCH BOX WIRING

Power for the switch box is accessed through the auxiliary plug located on the right rear of the cab. A John Deere plug is used, part number RE67651. DO NOT connect the plug to the cab port until the wiring is completed. The wires in the plug are colored RED, BLACK and ORANGE. Either the RED or ORANGE wire will always be hot, so it needs to be capped. Attach connector 34538 to end of the wire and tape wire back on itself. The other wires are hot when tractor key is turned to “on”. Connect the BLACK wire of the plug to the BLACK wire from the switch box. Then connect the other “Keyed Hot” wire of the plug to the RED wire from the switch box.

The two GREEN wires from the switch box must be connected to the neutral safety wire by cutting the neutral safety wire and connecting one GREEN wire to one end and the other GREEN wire to the other. The neutral safety wire is the black wire with the white stripe. **Use a test light or meter verify** this wire is the neutral safety wire. Cut the black wire with the white stripe and connect the green wires from the switch box as shown in the wiring diagram.

Route the cables and wires from the switch box along the right console back to the plug under the rear window. Cover the wires with wire wrap, cut a small cross hair pattern into the plug and route the wires through the hole. Attach the wires to the console with the push mounts. Mark where you want to route the cable. To avoid hitting any existing components remove the console so you can see where you are drilling. Drill three 1/4” holes in the console for the push mounts and replace the console. Thread a zip tie through the push mounts and push the mounts into the 1/4” holes. Do not snug the zip ties until all the wiring is complete. From the rear of the tractor, run the white wire to the solenoid valve. The travel lock orange wires from the switch box should also be covered with wire wrap and will be run with the white wire. These wires will be connected to the electronic travel locks located on the lift valve. (ASM-KUB-0035)

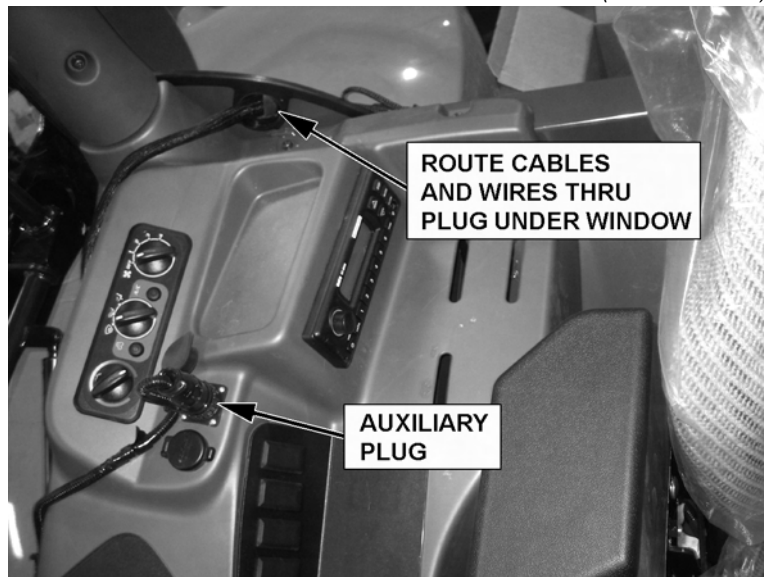

# ASSEMBLY

## VALVE MOUNTING

The valve mounting bracket is fastened above the rear remotes. The slots closest to the remotes use the existing hardware. The existing hardware is to be loosened until the bracket can slide under the hardware. Next, align the holes of the bracket to the holes in the tractor. Secure the bracket to the tractor with the hardware provided. Re-tighten the existing hardware. See the Parts Section for additional reference.

Next, attach the valve mounting plate to the mounting bracket. Align the holes on the plate to the holes on the bracket. Use the hardware shown in the parts section to attach the plate to the valve mounting bracket. Finally, place the valve on the valve mounting plate as shown in the parts section. Align the holes on the valve assembly to the holes on the plate. Use the hardware provided to secure the valve to the plate. Refer to the parts section for the placement of the valve and the hardware used. **Please handle the lift valve with care. It is extremely heavy and contains small parts.** (ASM-KUB-0006)

## MANUAL LIFT VALVE PORTS

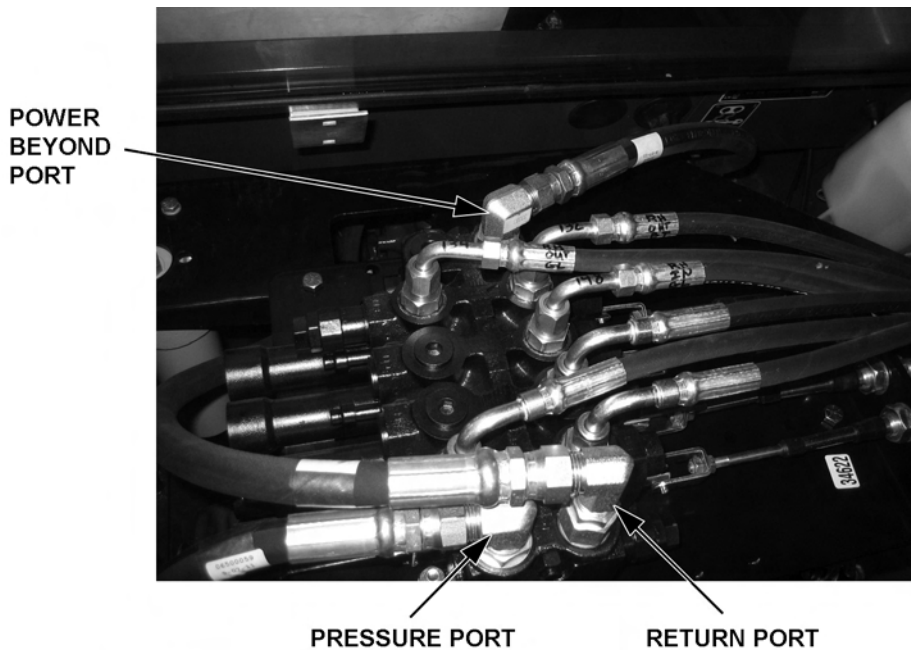

(ASM-KUB-0024)



# ASSEMBLY

## MANUAL SWITCH BOX MOUNTING

The switch box is to be secured to the operators side of the control handles, or valve stand. Refer to the parts section for assembly and components needed.

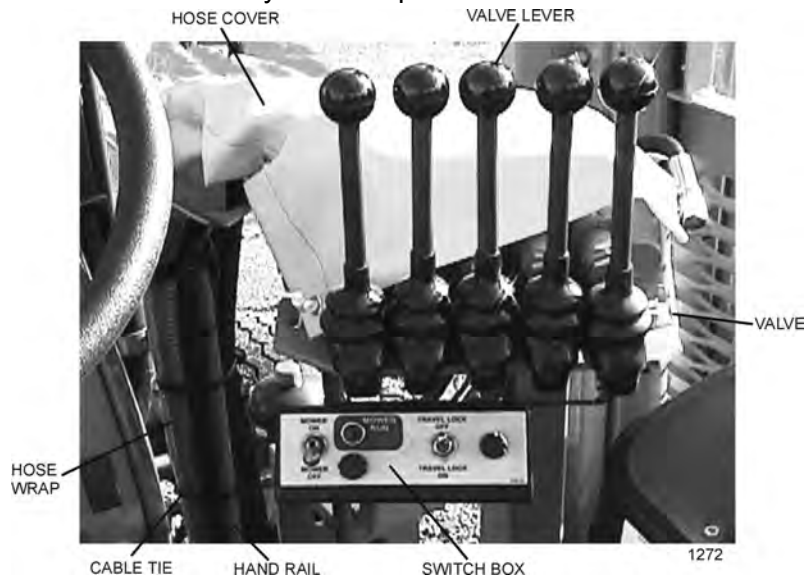

(ASM-C-0053)



# ASSEMBLY

## \*NOTE ON HUSCO CONTROL VALVES\*

Manual, cable controlled (Husco control valve) boom mowers require check valves with integral restricting orifice (#06502036) installed in the control valve work ports that are connected to the gland ends of the main and secondary boom cylinders. This check valve allows oil to free flow into the gland end of the main and secondary boom cylinders, but restricts flow out of the cylinder, thereby providing proper boom control. This check valve, #06502036 (Vendor #1968R-.063) is similar in appearance to hose adapter #33271 and Adapter #34396, with .06 orifice. These components can be identified as follows, and are to be installed per parts section for the lift valve. (ASM-HUSCO-0001)

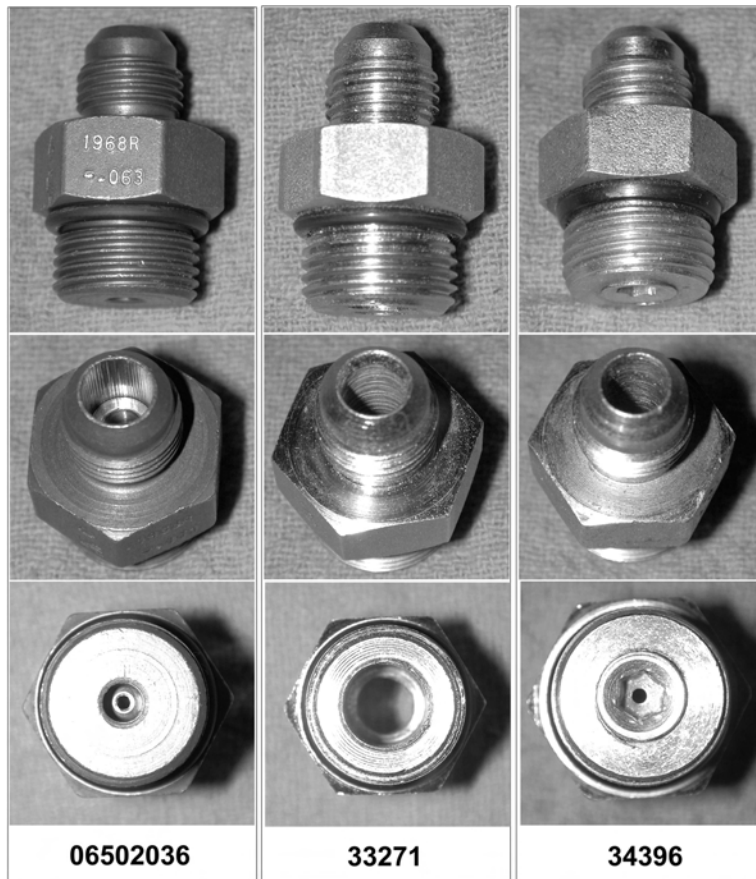

# ASSEMBLY

## JOYSTICK CONTROL MOUNTING BRACKET

Preassemble the joystick mounting as shown in the Parts Section. **Use the image below for positioning the joystick control bracket.** Position the support bracket on the floor as a template. The upper left hole of the bracket is 7-1/8" from the edge of the door and 6-3/4" from the corner post as shown below. The front corner of the bracket is 2-3/4" from the edge of the door as shown below. Mark the holes on top of the floor mat. Be sure that the location of the stand will allow clearance between the joystick and all existing interior levers, etc. Also watch out for wiring and brackets when placing the bracket for drilling and cutting. Cut holes in the mat with a 1-1/8" hole saw. The spacers provided are used to allow the control bracket to set on top of the floor mat while being held securely to the floor of the cab. Drill 3 holes for the capscrews using the bracket and spacers as a template. Then secure with the hardware as noted in the Parts Section. (ASM-KUB-0032)

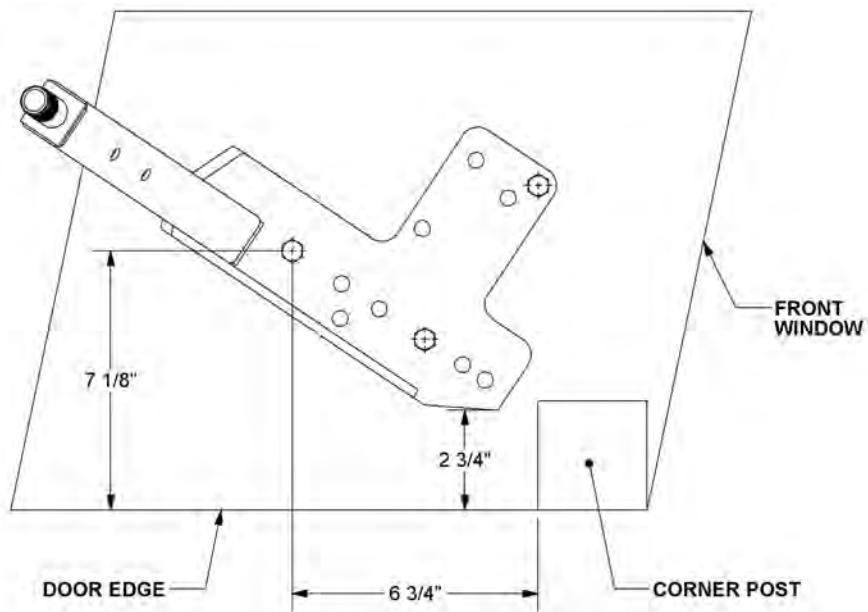

# ASSEMBLY

## ELECTRONIC LIFT VALVE PORTS

(ASM-C-0089)

### DANFOSS VALVE

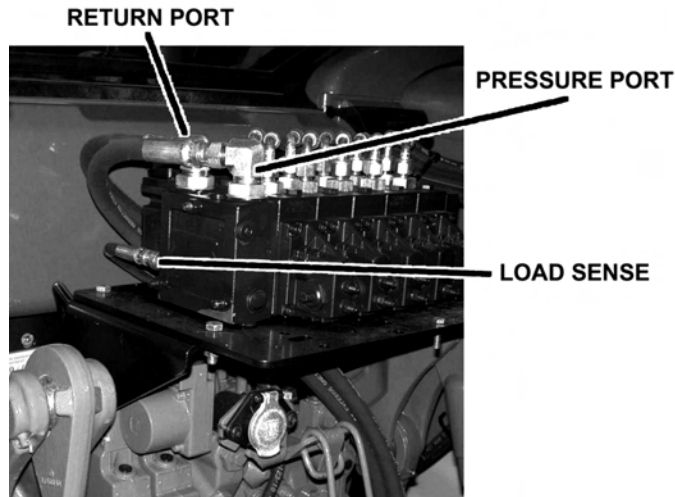

### SELECTOR VALVE INSTALLATION

**NOTE:** Refer to the parts section and illustration below for hardware and position.

The selector valve is attached to the boom rest. The 1/4" hoses from the swivel section of the lift valve are plumbed to the "A" and "B" ports on the selector valve. A run tee is added to the return section of the lift valve. Attach the 1/2" hose from the "T" port of the selector valve to the run tee on the lift valve. 1/4" hoses are attached to the "A1", "A2", "B1" & "B2" ports on the selector valve to the knuckle cylinder and swivel cylinder. (ASM-SLCTR VLV INSTLN-0001)



# ASSEMBLY

## BOOM JOYSTICK CONTROL CALIBRATION

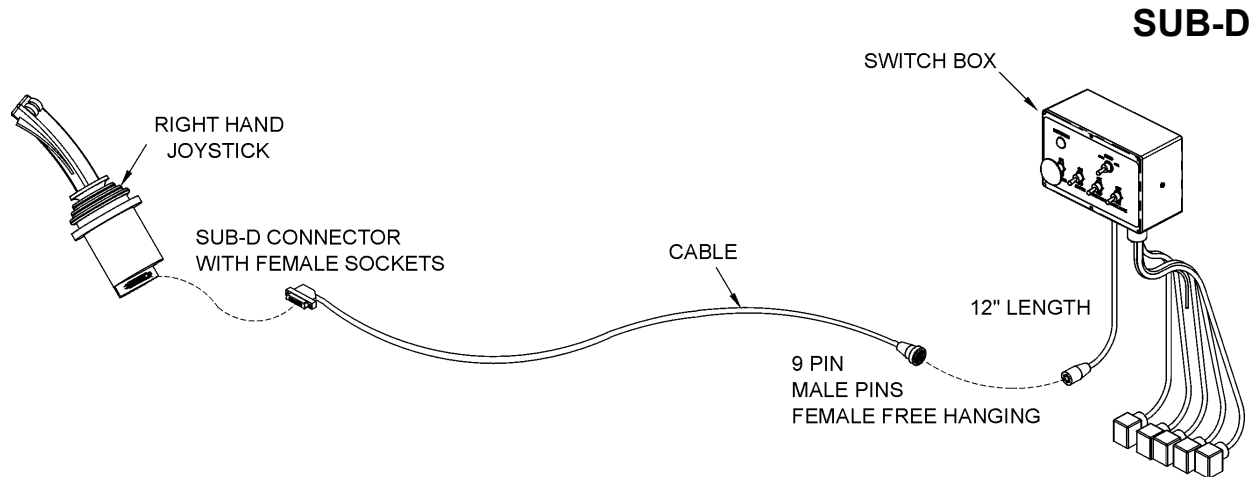

This Danfoss PVG32 control valve is now equipped with higher-resolution actuators on Main Boom, Secondary Boom, Deck Roll, and Swivel functions. These actuators have “active fault monitoring”. The Deck Shield section does not have “active fault monitoring”. The joystick is unchanged and provides a ratio-metric voltage signal. The neutral signal voltage is half or 50% of tractor supply voltage. A 25% signal voltage will shift the valve spool to full “A-Port”, and 75% signal voltage will shift the spool to full “B-Port” in the Main, Secondary, and Swivel valve sections. On the Deck Roll function a 34% signal voltage will shift the valve spool to full “A-Port” and a 68% signal voltage will shift the spool to full “B-port”. If an actuator with active fault monitoring receives a signal from the joystick that is less than 15% or greater than 85% of supply voltage the actuator will “fault out” and shut down. Also if there is an internal failure in the actuator or if the spool position is greater than that specified by the signal voltage from the joystick, the actuator will “fault out” and shut down. An “active fault” condition causes the actuator to drive the spool to neutral, shut down, and activate a “red” LED on the top of the actuator. The active fault can be canceled by simply cycling the Master Switch “OFF” and then “ON”, which resets the fault monitoring, and causes the LED on top of the actuator be “green” again..



The joystick control is equipped with signal adaption potentiometers.

These provide the capability to individually adjust the oil flow to each boom function. It is important that the boom functions do not travel too fast. Excessive boom speed can reduce the stability of the unit and decrease operator control.

Note: Use a Phillips screw driver and be sure to adjust the screws carefully! DO NOT turn the potentiometers beyond their stopping point, potentiometers are very delicate! Turning the “A” or “B” port potentiometers clockwise increases the oil flow to increase the boom function speed, and turning them counterclockwise decreases the oil flow to decrease the boom function speed. See the graphic on the next few pages for help in adjusting.



# ASSEMBLY

Run tractor at normal operating RPM to adjust the settings as follows.

## **Set the dead band compensation potentiometer first.**

Set the dead band compensation potentiometer at 50%, or halfway between full clockwise and full counter-clockwise.

## Setting Signal Adaptation Potentiometers:

Disconnect the Deutsch connectors from the actuators of the valve. Use a Volt/Ohm meter to measure signal voltage and adjust the signal adaptation potentiometers as needed. Pin #4 is tractor supply voltage. Pin #1 is signal voltage from the joystick, and pin #3 is ground. First measure supply voltage between pins 4 and 3. Then measure signal voltage between pins 1 and 3 while indexing the joystick function fully in both the "A" and "B" port direction. Divide the signal voltage by the supply voltage to get signal voltage as a % of supply voltage. This percentage should not be less than 25% or greater than 75% for the Main Boom, Secondary Boom, or Swivel function. This percentage should not be less than 30% or greater than 62% for the Deck Roll function. Note these initial settings for the Deck Roll function should prevent the spool from shifting into float. *After making this first adjustment to deck roll if the spool still goes into float, adjust the "B" port screw additionally counterclockwise.*

Reconnect Deutsch connectors on control cables to actuators on Danfoss valve. Run tractor until hydraulic system is at operating temperature. Now refine the adjustments of the signal adaptation potentiometers for both "A" and "B" ports for all proportional functions to achieve the following function times. Note: turning potentiometer clockwise increases the flow or the function speed, and turning them counter-clockwise decreases the flow or the function speed. Note, if during this procedure the trim potentiometer is set to full "counterclockwise" but the function is still too fast, use the mechanical stops at the manual actuator end of the valve section to further limit flow. Turn limit screw in or clockwise to limit flow. The upper limit screw limits flow to "B-port", and the lower limit screw limits flow to "A-port". However DO NOT adjust the limit screw on "B-port" of deck roll function. Limiting "B-port" will prevent "float" function.





# ASSEMBLY

**MAIN BOOM:** “A” Port, Boom UP: 7-9 Seconds

*(Note: Extend secondary boom completely; roll deck to be level with ground, and lower main boom until deck is on ground. Now index main boom “up” function and determine the time required for main boom to rise completely.)*

“B” Port, Boom Down: 6-8 Seconds

*(Note: Extend secondary boom completely, roll deck to be level with ground, and raise the main boom to “full up”. Then index the main boom “down” function to determine the amount of time required for the deck to contact the ground. CAUTION: Stop the boom just as the deck contacts the ground.)*

## SECONDARY

**BOOM:** “A” Port, Boom Out: 8-10 Seconds

*(Position main boom full up, roll deck out until deck cylinder is fully retracted, and bring secondary boom in completely. Then index the secondary boom “out” function and determine the time required for boom to extend out completely.)*

“B” Port, Boom In: 8-10 Seconds

*(Position the main boom full up, roll deck out until deck cylinder is fully retracted, and extend secondary boom completely. Then index the secondary boom “in” function and determine the time required for boom to come in.)*

**DECK ROLL:** “A” Port, Deck Out: 7-9 Seconds

*(Raise main boom to vertical, extend secondary boom out slightly so that deck can be articulated without contacting the main boom, and roll deck in until deck cylinder is completely extended. Then index the deck roll “out” function and determine the time required for the deck to roll out.)*

“B” Port, Deck In: Target 7-9 Seconds (but DO NOT use Limit Screw)

*(Raise main boom to vertical, extend secondary boom out slightly so that deck can be articulated without contacting the main boom, and roll deck out until deck cylinder is completely retracted. Then index the deck roll “in” function and determine the time required for the deck to roll in.)*

## BOOM

**SWIVEL:** “A” Port, Boom Aft: 14-16 Seconds

*(Extend booms completely; rotate head to be level with ground, lower main boom until deck is just above ground, and swivel boom full forward. Then index the boom swivel “aft” function and determine the time required for the boom to swivel aft. Use caution when doing this, stop boom before main boom contacts tire.)*

“B” Port, Boom Forward: 14-16 Seconds

*(Extend booms completely, rotate head to be level with ground, lower main boom until deck is just above ground, and swivel boom aft and until near tire. Then index the boom swivel “forward” function and determine the time required for the boom to swivel full forward.)*



# ASSEMBLY

(ASM-DF CALIBRATION LRS-0001)

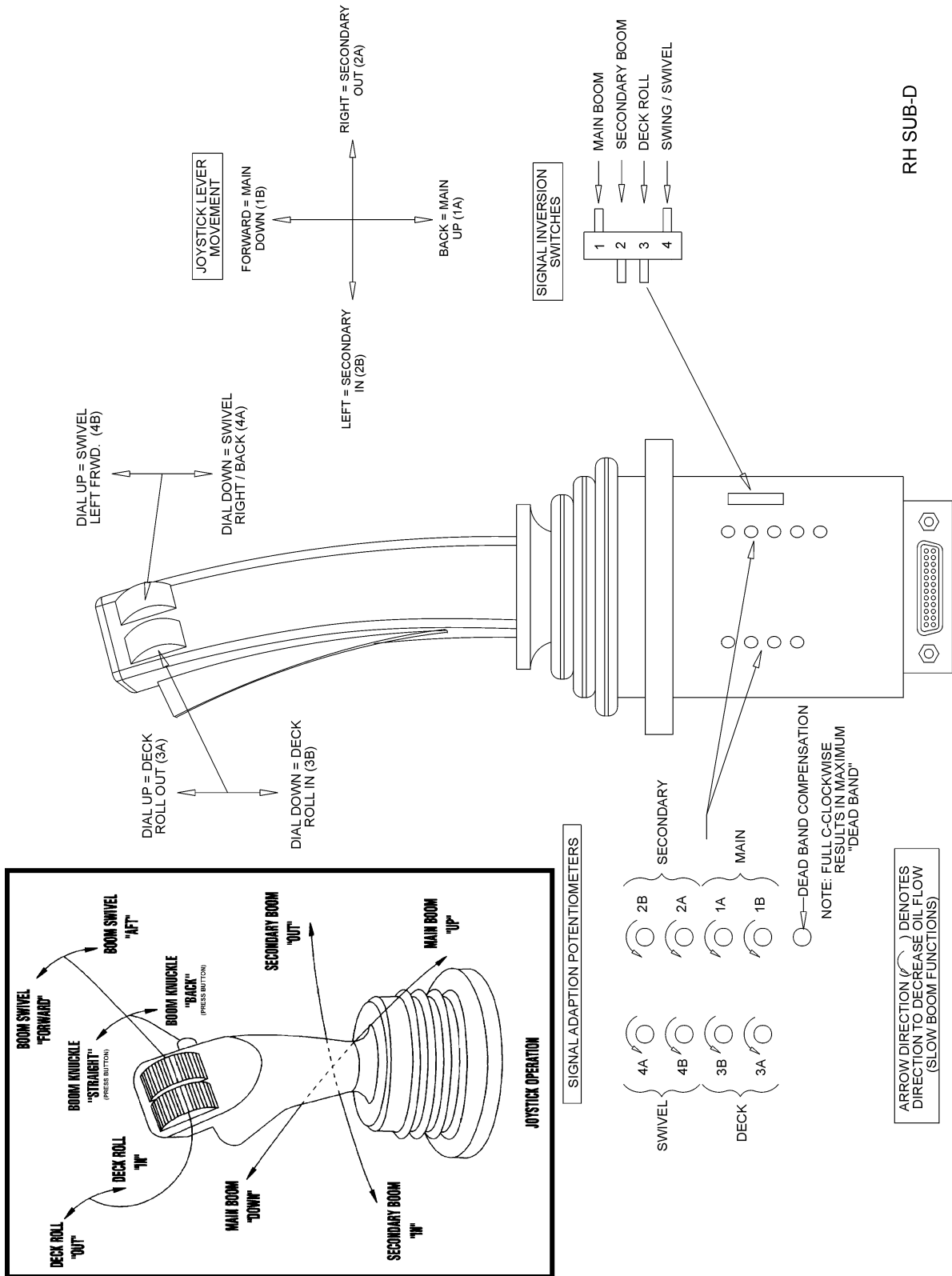

RH SUB-D

ARROW DIRECTION ( ) DENOTES DIRECTION TO DECREASE OIL FLOW (SLOW BOOM FUNCTIONS)



# ASSEMBLY

## BENGAL BRUTE HOSE ROUTING

**WARNING NOTE:** The sudden release of hydraulic pressure could cause the sudden movement of very heavy parts. Anyone in the way of these parts could be severely hurt or killed. DO NOT ALLOW these hydraulic hoses to BREAK or BURST in order to prevent hydraulic failure. Make sure the hoses do not pinch or stretch as boom moves. Measure TWICE, check TWICE then proceed with caution.

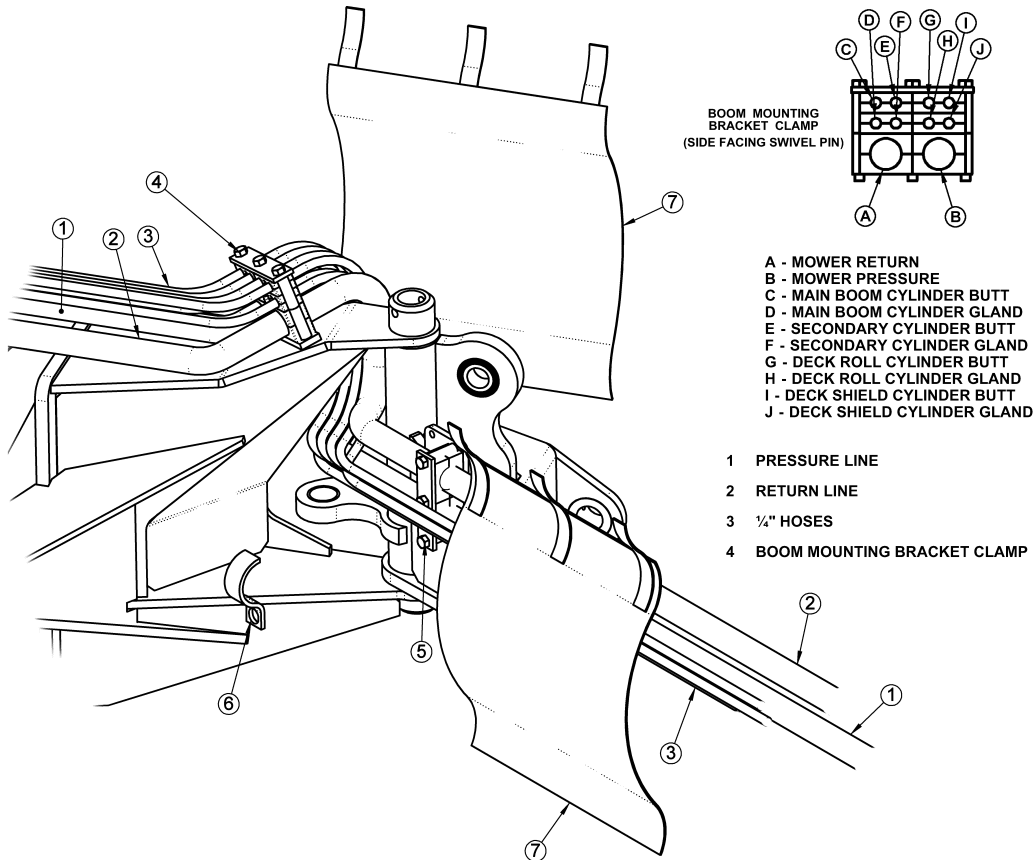

Mark the 1" return hose at 33" and 56" from the end that will connect to the preformed tube. These marks will be placed in the hose clamps. The 1" pressure hose should be routed to follow the return hose. Route the hoses through the space between the swivel and the boom mounting bracket. Connect the hoses to the preformed tubes and move the boom arm to a few feet from full forward. Assemble the swivel clamp and place the return hose for the motor on top and the pressure line on the bottom. Place the 1/4" hoses in the "C" clamp and add it to the bottom screw of the swivel clamp. Next, make sure there is enough slack for all hoses to pivot at the joint where the main boom arm bends in the swivel, as shown in the next image, and tighten the hoses in the clamp.



# ASSEMBLY

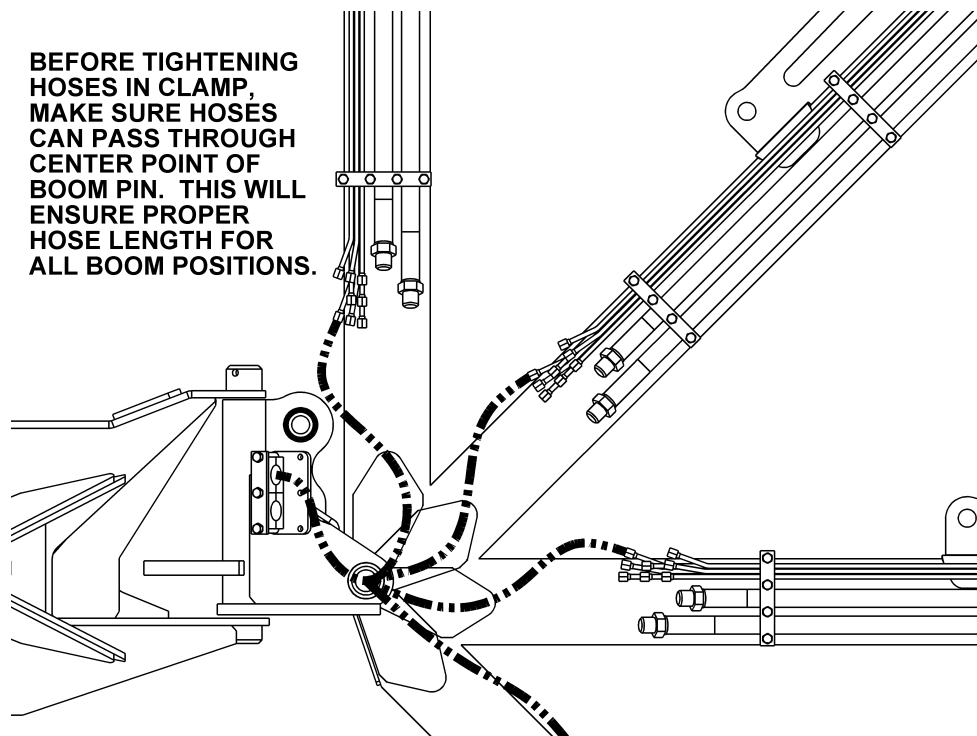

Arrange the hoses in the clamp that attaches to the boom mounting bracket as shown above, with the 1" motor hoses closest to the bracket and the return hose closest to the boom arm. Pull the hoses snug from the swivel to the mounting bracket clamps, when main boom is still forward, and tighten the hoses in the clamp.

Make sure the 1" motor hoses do not kink as the boom arm is moved into the stowing position. If this happens the motor hoses will have to be shortened, because there is too much hose between clamps. (ASM-BRUTE HOSE ROUTING-0001)



# ASSEMBLY

## LIFT HOSE CLAMPING & ROUTING

Attach a clamp to the right rear wheel well for proper hose routing. Drill a hole for the clamp. Use the lower rear corner of the wheel well as an origin for measuring. The holes should be 10mm or 3/8" reamed to accept 3/8" hardware.

Measure from the bottom edge of the wheel well 8" from the origin. Use a square to measure 4-1/4" in from the last mark. Refer to the image below to locate the hole.

**NOTE: DO NOT CUT INTO TUBES / HOSES / WIRES WHEN DRILLING THROUGH METAL OR PLASTIC!. (ASM-KUB-0037)**

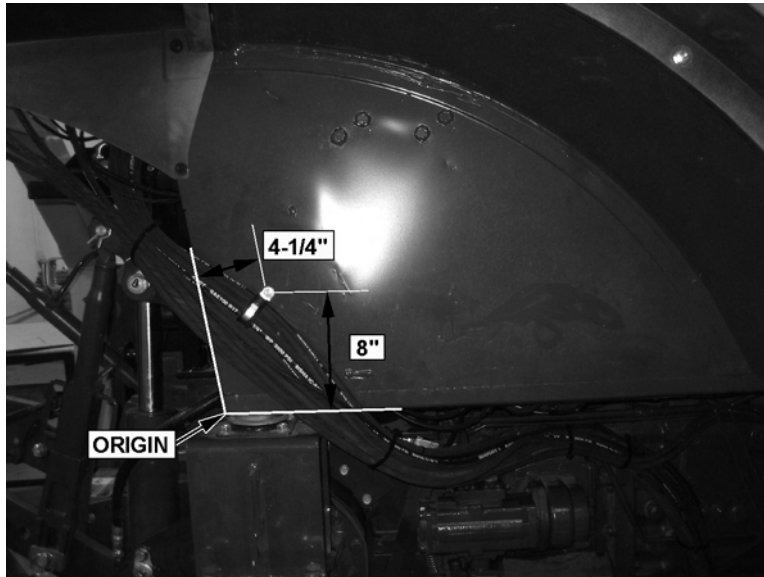

Place as many hoses in the clamp that will fit without compromising pressure. Then secure the HOSE CLAMP (06520013) to the holes drilled with a CAPSCREW, 3/8" X 1" NC (21630) and a NYLOCK NUT, 3/8" NC (21627). The hoses that don't fit into the clamp are to be secured to the others with zip-ties. For protection of hoses in contact with metal edges, wrap hoses with spit hose sections and fasten with hose clamps or zip ties as needed.



# ASSEMBLY

(ASM-C-0094)

## REAR STOW BOOM HYDRAULIC DIAGRAM

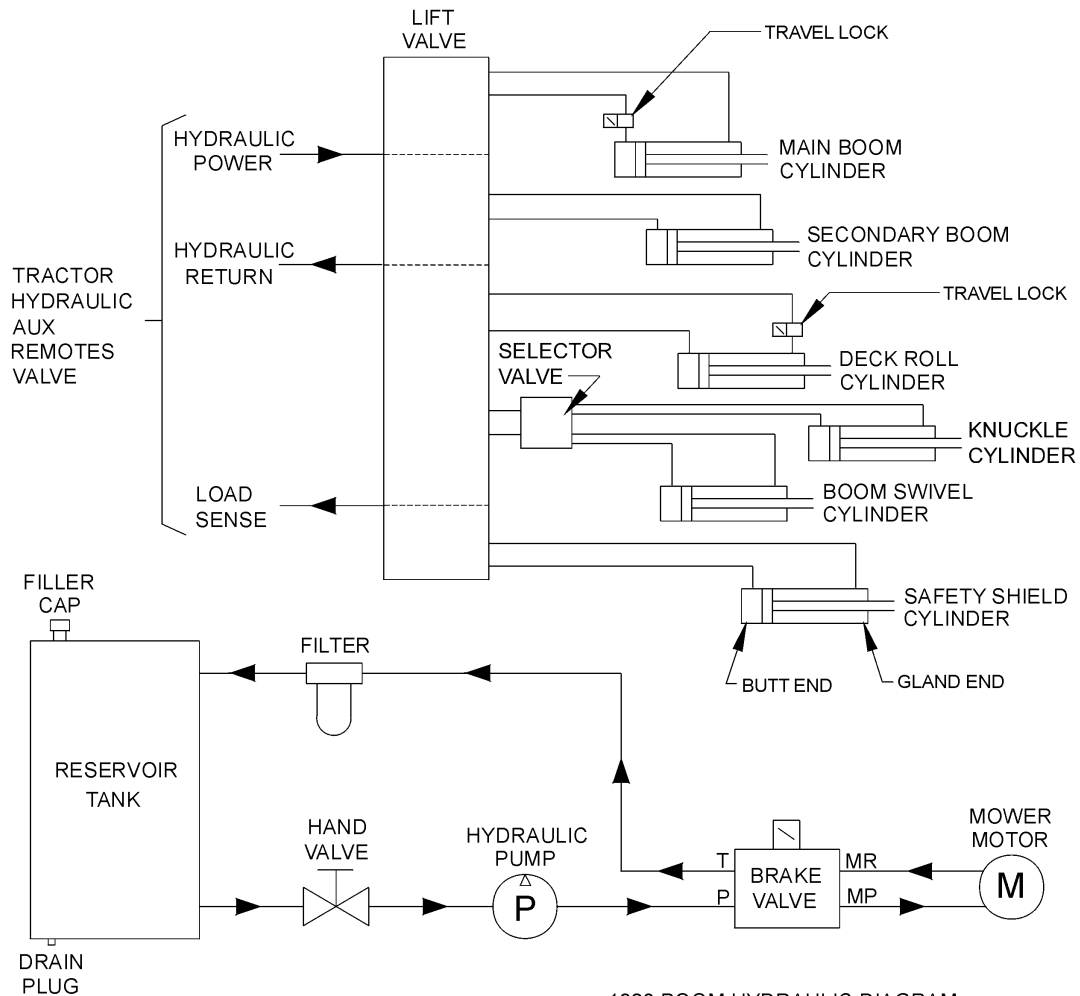

1320 BOOM HYDRAULIC DIAGRAM

## SIDE HYDRAULIC TANK INSTALLATION

Install all fittings and tubes into tank and tank filter as shown in the Parts Section illustration. Insert tank sight glass into front side of tank.

Place the tank in the mounting bracket on the main frame as shown in the Parts Section. Secure the tank with the tank channel mount by placing the channel mount on top of the tank and the washers over the holes. Thread the tie bolts through the washers and holes to the threaded holes on the main frame. Tighten the tank channel mount by using the hex heads on the end of the tie bolts.

Install the filter gauge into the filter housing so that it points to the rear of the tractor and is clearly visible to the operator. The tank breather cap is ready for use as the tank is filled. Some of the for-mentioned items may be already installed. (ASM-MOTOR HYDRO-0001)



# ASSEMBLY

## FILLING HYDRAULIC RESERVOIR

Refer to the maintenance section for filling specifications and hydraulic oil requirements.

**NOTE: Starting or running your Tiger mower before filling reservoir will cause serious damage to hydraulic pump.**

*(ASM-C-0004hydro resrv)*

## INSTALLING O-RING FITTINGS

Installing straight, 45° and 90° O-rings requires that the O-ring and washer be up against the swivel body. Insert the swivel and turn in until the swivel is pointed in the desired direction and O-ring contact is made. Hold swivel in set direction with a wrench and turn the O-ring nut away from the swivel body and carefully tighten. *(ASM-C-0056)*

## INSTALLING NATIONAL PIPE FITTINGS

Whenever installing a pipe fitting, wrap the threads clockwise (looking at the end) with teflon tape. In this way, the tape will be tightened when installed. NOTE: It is not necessary to tape O-ring fittings, or those installed in swivels. *(ASM-C-0088)*

## GENERAL HOSE INSTALLATION

Refer to the parts section for detailed information about hoses and fittings for this application.

*(ASM-C-0011)*

## HOSE COVERING

Secure hoses together with zip ties wherever loose. Wrap the hoses with the hose covers as illustrated in the parts book. Where hoses may contact the frame or other edges, wrap with split hose and secure with hose clamps or zip ties. On non cab units the pressure and return hoses from the control valve will also need to be routed inside the protective clear hose wrap.

*(ASM-C-0019)*

## SOLENOID BRAKE VALVE

Install a solenoid valve on the mounting bracket with the supplied hardware as shown in the Parts Section in this manual. While installing the fittings to the brake valve, the electrical coil on the spool may have to be removed to make room. When reinstalling the coil, it is important to use no more than 5 ft. lbs. (or 60in. lbs.) torque. WARNING: OVER TORQUE TO THE COIL WILL RESULT IN HYDRAULIC FAILURE OF SPOOL. *(ASM-C-0025)*

## ACCUMULATOR INSTALLATION

Install the accumulator bracket on the right main frame mast or lift valve mount, if applicable, with the capscrews, lockwashers and spacers, if applicable, as shown in the Parts Section. Install the accumulator in the bracket and secure with the hardware shown. Install fittings and hoses to the cylinder and control valve as shown in the Parts Section. **Use teflon tape on all pipe fittings (except O-rings).** *(ASM-C-0012)*



# ASSEMBLY

## ACCUMULATOR INSTALLATION - BULKHEAD

To install the accumulator, two holes will have to be drilled and tapped in the location shown below. Install the bracket on the main frame mast as shown below, then install the accumulator in the bracket and secure with the hardware shown. Install fittings and hoses to the cylinder and control valve as shown in the Parts Section. **Use teflon tape on all pipe fittings (except O-rings).** (ASM-C-0108)

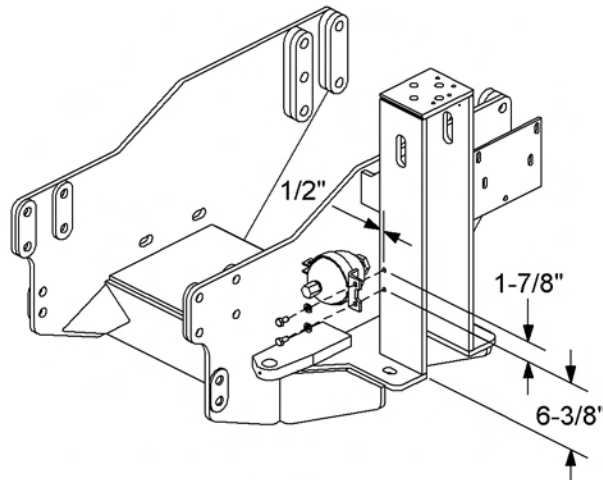

**TAP 2 HOLES: 3/8-16 THREADS**

## TEMPERATURE GAUGE MOUNTING (OPTIONAL)

Mount the temperature gauge where it is clearly visible to the operator. Attach the green (-) wire from the negative post on the gauge to a grounded bolt on the tractor frame. Remove paint if needed to make a good ground. Remove the pipe plug from the side of the hydraulic reservoir and install the temperature sensor using thread sealing tape. Run the white wire from the (s) sensor post of the gauge to the temperature sensor on the hydraulic reservoir tank. (ASM-C-0051)

## WHEEL WEIGHT MOUNTING

For all tractors using a boom mower, a wheel weight will be required for the rear left side wheel. It will be necessary to mount the weight in the wheel using the long capscrews, lockwashers, flatwashers, spacers (if applicable), and hex nuts per the diagram in the parts section.

Installation is most easily done with a fork lift, inserting a fork in the center slot of the wheel weight. The head of the capscrews is to be toward the OUTSIDE of the weight, with flatwashers on both the inside and outside of the assembly.

The left rear tire may also be filled with a mixture of water and calcium chloride at about five pounds per gallon. Tire air pressure should be maintained according to the Maintenance Section. (ASM-C-0055)





# ASSEMBLY

## BULKHEAD DIAGRAM

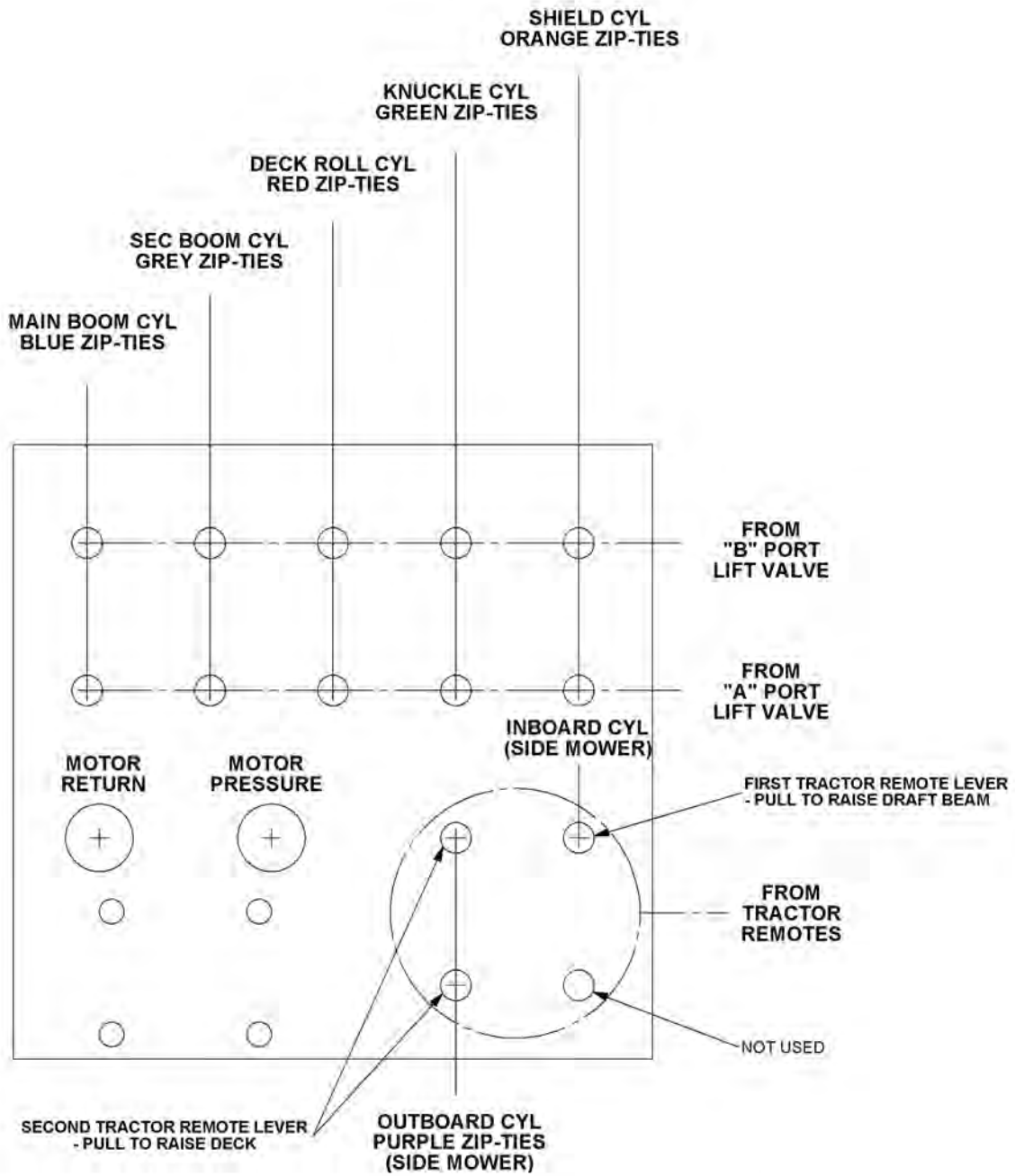

(ASM-C-0107)



# ASSEMBLY

## COOLER MOUNTING - SIDE TANK

Mount the cooler mounting brackets on the top rear side of the side hydraulic tank. Locate the bolt plates on the top of the tank and secure the appropriate cooler bracket to the tank with the hardware provided. Attach the screen and cooler to the brackets. Refer to the Parts Section to attach the hoses and adapters to the cooler. (ASM-C-0092)



## AXLE BRACE INSTALLATION

With the tractor on jack-stands, remove the existing hardware and the three-point links on the rear axle where the axle braces will be mounted. Use a hoist to raise the axle braces to the correctly matching mounting holes on the rear axle and the main frame. Use the new capscrews and existing hardware and clamp bar to attach the braces to the tractor. DO NOT tighten the hardware at this time. Remove the capscrews one at a time and apply a thread locking agent. Reinsert the capscrews and tighten / torque to values noted in the torque chart located in the maintenance section of this manual. (ASM-KUB-0036)



# ASSEMBLY

## RS AXLE BRACE MOUNTING

The rear stow axle braces are to be mounted under the rear axle of the tractor. The other end of the axle brace mounts on the outside of the lower rear corners of the main frame. After attaching the boom rest, it should fit tightly and level under the tractor. Attach the axle brace(s) to the main frame with hardware shown in the Parts Section and tighten. Attach the axle braces to the rear axle using the mounting hardware shown in the parts section, but **DO NOT** tighten.

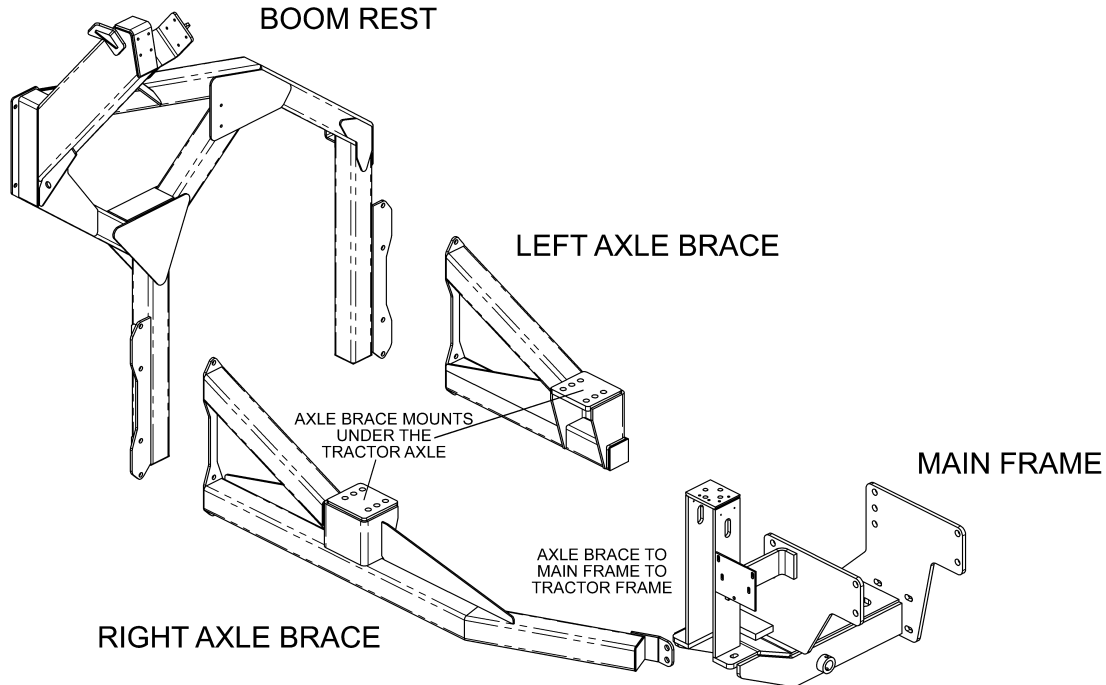

## RS BOOM REST MOUNTING

Carefully raise the rear stow boom rest and align the holes with those of the axle brace. Now install all attaching hardware as shown in the parts section loosely, to allow for the alignment with the left and right axle brace. Tighten / torque all hardware on the brace and the boom rest. Finally, add the rest strips to the boom rest as shown in the Parts Section. (ASM-JDBOOM-0001)

## MAIN BOOM INSTALLATION

Install the boom swivel into the main frame as shown in the parts section using a hoist. Line up holes in swivel and main frame for large swivel pin and insert pin. Secure with hardware as shown.

Attach the inner end of the main boom to the swivel bracket with the cylinder anchors positioned upward, and at a right angle to the tractor. Secure it with the horizontal hinge pin. Secure the hinge pin in the boss with capscrews, etc. (see Parts Section).

Attach the butt end of the main boom cylinder to the swivel with the cylinder pin and roll pins shown in the Parts Section.

Install the travel lock on the rod end of the main boom cylinder. This should be facing the butt end of the cylinder after installation.

Install the fittings and hoses to the main boom cylinder per Parts Section.

**GREASE HINGE PIN ZERKS ON BOOM AFTER ASSEMBLY, ONCE UNDER LOAD WITH BOOM ELEVATED AND AGAIN AT REST WITH BOOM SUPPORTED** (ASM-C-0013)



# ASSEMBLY

## DECK ATTACHMENT

Attach the head to the secondary boom using the pins and hardware shown in the parts section to attach linkages. Install the square tube on the top of the head into the head mount and secure using the mounting plate and hardware as shown. The mount should be positioned to the left side of the cutter head. Install the deck pivot cylinder using the pins and hardware also shown in the parts section.

Connect the fittings and hoses from the pivot cylinder to the small preformed tubes on the boom arm. Connect the fittings and hoses from the motor to the large preformed tubes on the boom arm.

Connect all remaining hoses from the control valve to the cylinders and / or preformed tubes on the boom arm. Refer to parts section for diagrams.

**Before proceeding to the final preparation step double check the complete assembly from the main frame to the cutter head against the diagrams in the parts section for proper placement and assembly of all components.** (ASM-C-0060)

## BOOM MOUNTING BRACKET

Using a floor jack and / or a hoist, raise the boom mounting bracket up to level and slide the bracket into position onto main frame as shown in parts section.

Install pin through main frame and bracket. Secure with cap-screw, lock-washer and hex nut through boss on main frame as shown.

Secure mounting bracket to main frame with the cap-screws, lock-washers, flat-washers, cut flat-washers and hex nuts provided. Secure using the two slotted holes on the bracket and main frame. (ASM-C-0014)

## SWIVEL BRACKET MOUNTING

Install the boom swivel bracket onto the boom mounting bracket with the swivel pin. Secure the pin in place using the capscrews, etc. through the hole in the boss and pin. NOTE: The head of the capscrew must be toward the front of the tractor.

Install all new swivels and fittings on the swing cylinder with swivel openings facing each other. Fittings will vary in type and direction depending on your application, refer to your parts section for more details.

Install bearings in the main frame anchor for the swing cylinder. This may already be done for you.

Install the swing cylinder between the boom mounting bracket cylinder anchor and the boom swivel with the pins. Insert roll pins through the top and the bottom hole in the pins.

Now the hoses can be attached from the control valve to the swing cylinder. (ASM-C-0015)



# ASSEMBLY

## GREASELESS BEARING INSTALLATION

It is recommended that grease is to be applied to the bore to aid in insertion of the greaseless bearing. (ASM-GRSLSS BRNG-0009)

### Assembly

When a PolyLube™ bearing is press fit into a housing, it expands into the housing and creates a highly loaded press fit condition. This is possible because of the elastic properties of the bearing's backing material. Press fits on wall thicknesses up to 1/8" have demonstrated

that the close-in ratio is one-to-one (0.001 press yields a 0.001 close in). However, press fits should be minimized, even though the tube will readily take presses of 0.004" to 0.005". The use of a standard H7 housing bore is also recommended.

Due to thermal lag, the bearing wear surface may be hotter than the adjacent housing, when heat is generated from running friction. As a result, the installed bearing may expand inward, reducing the shaft clearance. For optimum performance, Polygon recommends a smooth, hardened steel shaft with a 16 micro finish. However, PolyLube's rugged bearing surface will permit use of a rougher finished shaft, such as a standard drill rod, if the bearing to shaft clearance is increased. (See Part # listings for recommended shaft clearances).

Shaft clearances should be increased for dry running applications with high rubbing velocities. Fluid cooling and lubricants will reduce the operating temperatures, permitting tighter shaft clearances. Heat transfer through the bearing wall is inversely proportional to the wall thickness. The thinner the wall, the greater the transfer of heat. Thermal conductivity, for example, is 1.8 to 2.3 Btu • in/(hr • ft<sup>2</sup> • °F).

Typical installation tools are illustrated below:

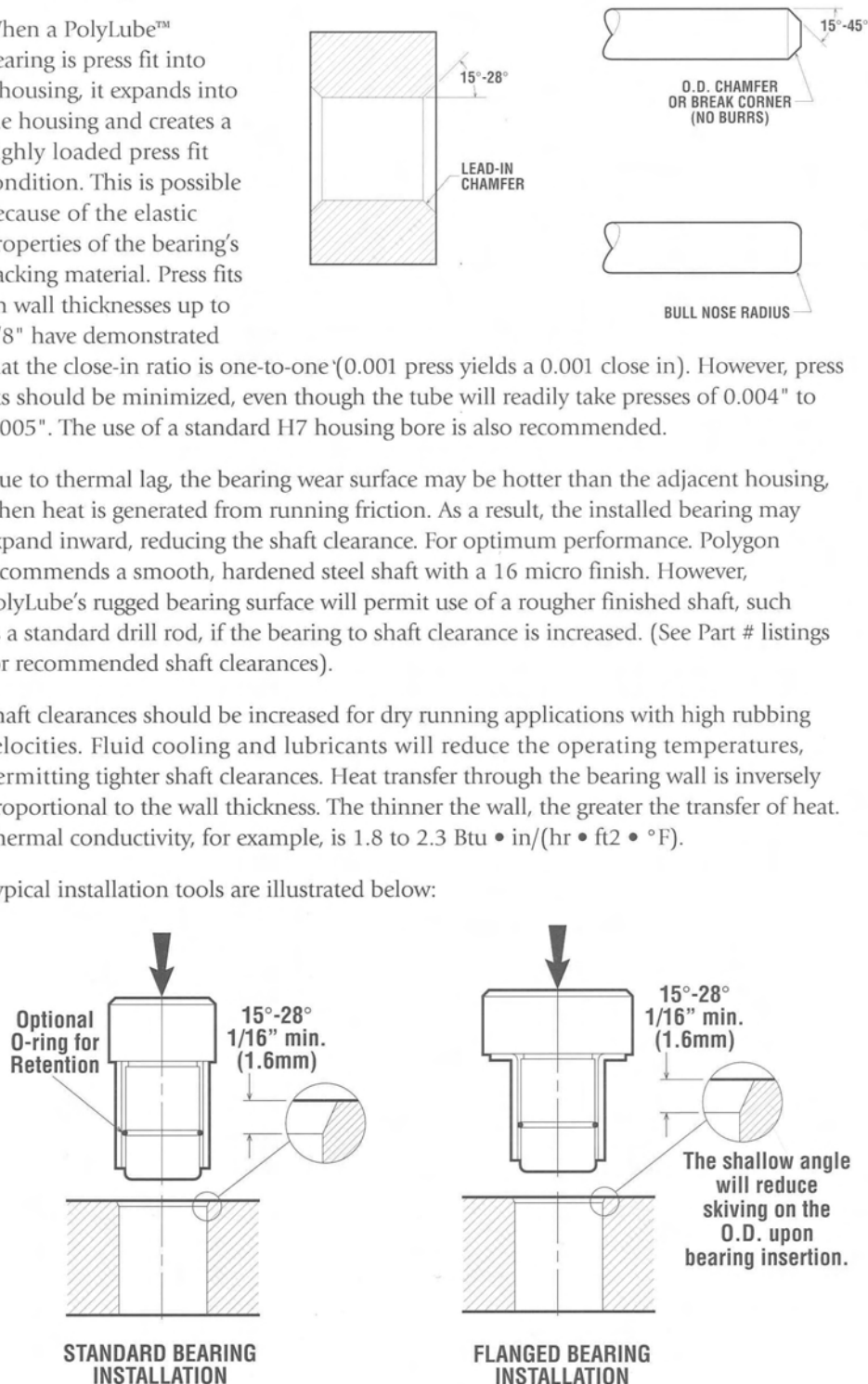

# ASSEMBLY

## FINAL PREPARATION FOR OPERATION

Place operators safety and operation decals on the steering column and side cover where they are clearly visible to the operator. These decals should be understood by each operator of the machine in conjunction with the safety and operation section of this book. The decals are to be maintained in good condition as a reminder to the operator, and should be replaced if damaged.

Finally, all bosses, pins and pivot points will need to be greased as instructed in the maintenance section of this manual. The hydraulic reservoir can also be filled with the recommended fluid (see maintenance section) and the filter installed in the top of the tank. Double check all fittings and fasteners BEFORE starting tractor. Also secure any loose hoses together with zip ties and wrap with split hoses where friction may occur on the hoses.



**BEFORE** starting or operating the tractor you must read and understand the safety and operation sections of this manual completely.

**BE SURE THE BALL VALVES ARE OPEN!** Start tractor and allow instruments to stabilize. Using a piece of paper or cardboard as noted in the safety and maintenance sections, check all fittings and connections for hydraulic leaks.

If a leak is found, you must shut down the tractor, set the cutter on the ground. Before attempting to fix the leak, you must actuate the lift valve handles several times to relieve any pressure in the lines.

**Before operating the mower**, the cutter head and boom should be slowly moved throughout the full range of motion. Watch for any condition that would cause pinching or excess stress on the hoses. The steering and front axle travel should also be carefully moved through their full range of motion. If any condition occurs in which the hoses contact the tires, the steering and / or front axle travel may need to be limited as described in the tractor operators manual. This should also be done if the tires rub, or are extremely close to any other part of the mower such as the hydraulic tank or draft beam. This may include adding shims, or adjusting stop bolts in the tractor front to solve the problem. While checking motion, you should also check that the control circuits are connected according to the operators decal for the valve handles.

## MOWER TESTING

Take the tractor to a place free of loose objects on the ground. Operate the cylinders through their full range of motion again, to clear the lines of air. Follow the instructions in the operation section to operate the mower. Vibration of the mower should be minimal at all times. After a 5 minute test run, the knife bolts should be retorqued and once again after the first few hours of operation.

**If any parts of this assembly section, or any other section of this manual are not clearly understood you must contact your dealer or the address on the front of this manual for assistance!***(ASM-C-0010)*



# OPERATION SECTION

U] ^:aa } A^&a } A-E

# OPERATION

## TIGER BOOM MOWER OPERATING INSTRUCTIONS

OPERATION

Va^i^A^O^[[{ • A^e^A^ e^ ~ e^c^ i^a^A^ a^A^ ~ a^c^ A^ e^ i^a^A^ A^ a^i^a^A^ i^i^i^• E^A^@^A^O^[[{ A^i^ A^i^• a^ } ^a^A^ A^e^c^e^O^i^ A^e  
d^e^d^ i^A^e^ a^A^ ] ^i^e^A^c^e^a^ ~ • A^@^e^e^• A^i^ A^e^A^ a^i^A^ e^ \* ^A^ A^c^\* ^e^e^A^ A^ e^ e^ } e^ &^ A^e^ ] | A^e^e^ } • E^A^@^A^[[{ A^e^ a  
@^e^e^• A^e^A^ ~ } a^ ] ^a^A^ a^O^i^ e^e^c^ A^ e^ } a^ \* A^i^&^e^ E^i^ i^ c^&^c^A^i^A^ i^&^d^ i^• E^i^ @^i^a^• E^e^ a^A^ @^i^A^ e^e^c^ A^ e^ i^• A^c^  
i^i^ c^e^A^A^ ] ^i^e^e^ i^A^e^ a^A^ e^• i^a^ A^i^ c^&^c^ } E^i^Q, ^c^i^E^i^ [ A^ @^i^a^a^ \* A^ F^E^E^A^ A^e^&^ i^e^ E^i^O^E^S^S^A^ e^e^c^ A^ ~ } a^ { ^ } o^e^ } a  
• e^e^c^ A^ e^ } a^ \* A^i^&^e^ A^ ~ • o^A^A^ e^e^ e^e^ a^A^ } A^@^A^ } a^i^ A^ i^i^ a^A^ ] ^i^e^e^ } e^A^i^ } a^a^i^ } A^e^e^i^A^ ~ • E^

Q^A^ A^@^A^ ] ^i^e^e^ i^c^ A^•• ] ] • a^i^a^c^ A^c^ A^A^ } [ ] i^a^\* ^e^e^i^A^ A^c^i^A^ ] c^ } e^e^A^ ] ^i^e^e^ \* A^e^ e^a^• A^e^ a^A^ A^c^e^ A^c^i^  
i^A^e^ ] e^e^i^A^ i^A^e^e^ c^i^ } A^c^ A^ } • i^A^ } ^•••• E^i^ c^o^i^• E^e^ a^ e^ E^e^ a^A^ i^i^ i^c^ A^e^A^ ] o^e^ b^i^a^A^ i^A^e^ e^e^ a^A^ A^• A^c^  
a^[[{ A^ } a^i^a^ e^e^d^ i^A^ i^A^e^e^O^ ] ] } A^ a^b^&^E^i^O^ A^ ] o^i^ ] ^i^e^e^ A^@^A^[[{ A^e^ a^A^e^e^@^a^A^@^e^e^A^i^• e^e^ a^i^• E^i^ e^•••• a^• E^  
] ^c^ A^ i^A^c^• d^ &^ A^e^A^ a^O^i^ A^E^E^A^•c^i^ A^@^A^ } a^E^

V^@^ A^A^&^c^i^ } A^ A^@^A^ ] ^i^e^e^ i^c^ A^ e^ } e^A^ A^i^• a^ } ^a^A^ A^e^ e^e^e^a^ E^i^• d^ &^c^i^e^ a^A^ a^ e^e^A^ ] ^i^e^e^ i^• A^c^ A^@^A^ e^e^A^e^ a  
i^i^i^ ] ^i^A^•••• A^• A^c^@^A^[[{ A^e^ a^A^e^e^@^a^A^@^e^e^A^i^• A^i^ } e^e^ a^A^ A^i^ A^c^i^ } A^e^A^e^ c^ } a^A^A^ A^i^A^•••• A^e^ A^e^  
c^a^ ~ e^A^e^e^A^ A^e^• a^ o^e^ A^c^ ] e^e^ a^ \* A^c^@^A^ ] ^i^e^e^ } A^ A^e^O^[[{ A^e^ a^A^e^A^ ] c^i^ ] ^e^e^A^ A^e^O^[[{ E^i^U^[[{ ^A^ A^c^ i^• A^ e^  
• Q, A^ @^i^a^• A^ } [ c^A^A^ A^ } @^e^ &^ A^c^a^ ~ e^A^e^e^c^ E^i^O^X^O^U^A^ ] ^i^e^e^ A^@^A^[[{ A^ } a^i^ a^O^i^ ~ o^e^i^A^ e^e^c^ A^ ~ } a^ { ^ } o^e^  
] | e^e^A^e^ a^A^ A^ i^i^ a^A^ ] ^i^e^e^ } e^A^ &^ ] a^a^i^ } E^i^A^@^A^ ] ^i^e^e^ i^A^ ~ • o^A^A^e^ e^e^e^A^ a^O^i^@^A^[[{ A^ } a^i^ e^e^ a^A^c^e^d^ i^  
] ] ^i^e^e^ } A^e^ a^A^e^i^A^ e^e^c^ A^ i^e^e^e^• A^i^ i^A^ A^•••• a^ } a^ \* A^ ] ^i^e^e^ } E^i^U^[[{ ] ^i^A^ ] ^i^e^e^ } E^i^e^ A^i^ e^e^ a^A^ A^c^i^ A^ e^ } e^A^i^ a^i^  
@^i^ ] A^ } • i^A^A^e^• A^ A^e^A^e^ a^A^ e^e^ e^e^d^ i^• A^•••• A^• A^c^@^A^[[{

**READ AND UNDERSTAND THE ENTIRE OPERATING INSTRUCTIONS AND SAFETY SECTION OF THIS MANUAL AND THE TRACTOR MANUAL BEFORE ATTEMPTING TO USE THE TRACTOR AND IMPLEMENT.** Q^A^ ] ~ A^i^ A^ ] c^i^ } a^i^• e^e^ a^A^e^ ~ A^ A^c^@^A^• d^ &^c^i^ } E^i^e^ } e^e^e^O^ i^A^ A^e^• A^e^ c^o^i^ a^A^ A^i^A^ e^e^i^A^ i^A^e^  
~ ] ] A^c^ ] e^e^ e^e^ } E^i^U^e^ A^i^ ] • A^e^e^ } c^i^ } A^c^ A^e^i^A^ e^e^c^ A^ a^ } • A^e^ a^A^ e^e^c^ A^ •••• e^e^• A^e^ ] e^e^ a^A^ A^c^@^A^ e^e^ } e^A^e^ a  
c^o^• A^e^ e^e^ a^A^ A^c^@^A^ ] ] { ^ } o^e^ } a^A^ e^e^d^ i^E^i^O^E^S^S^A^ (OPS-U-0001)

ÜÖCÖE^A^P^ÖÖÜÜVÖP^ÖE^e^ a^A^U^ŠŠUY A^c^@^A^ ] ] ] , a^ \* A^i^e^c^ A^•••• e^e^• E^i^U^i^a^ ~ • A^e^ b^i^ A^i^  
a^A^e^e^i^ e^e^ A^ &^ i^A^ ] •••• A^e^e^ A^e^ A^e^ } A^c^ A^c^ ] ] ] , A^c^@^A^ e^e^ } a^ \* A^e^ a^A^• d^ &^c^i^ } • A^e^e^ a^A^ A^c^  
Üe^c^ A^•••• e^e^• E^i^O^E^, e^e^• A^•••• A^[[{ a^A^i^ } { [ ] A^ } • A^i^ A^e^e^ ] a^A^e^ e^e^a^• E^i^O^E^S^S^A^

**SAFETY INSTRUCTIONS**



**PELIGRO**

U^a^ ] A^•••• A^•••• ] • E^i^ a^e^e^e^ a^e^e^e^ ~ } a^ } A^•••• A^c^i^ A^c^i^ e^e^e^ ~ ^A^ A^c^i^ : e^e^e^e^  
{ ^a^e^e^ A^i^A^•••• i^e^e^e^ E^i^O^E^S^S^A^

**LEA EL INSTRUCTIVO!**



Ö[[{ U ] ^i^e^e^ } A^i^&^c^i^ } A^E^G







# OPERATION



Ð^ç^!Á] ^!æ^A@AV!ædq |Aæj áAT [, ^!AM) áA) áQ ~ ^æj AUUUQU] ^!æj |  
Ú:| ç^&ç^ÁÚd ~ &c |^DÁ |ÁÓææÁç |Á: ^ç^ ^) áq b i^ Á: { Á áb &ç^ Áç | , } Á: {  
\* | [ ~ ) áÁ |Á: { Á ç^! @ææÁá { á \* ÁÚd } Á [ , á \* ÁÁ [ | \ ^! Á | Á æ • ^! • à^  
æ^ Á) áç | Á HÇÁ^ ÁÇÁ PÓT ÈD



### 2.3 Tractor Lighting and SMV Emblem

Q@ç^ædq |Á) á|Á^Á] ^!æ^áÁ^æÁ |Á:æ^ |Á) Áæ  
] ~ á|ÁÁ [ ææ, æ ÁáÁ ~ • ç^Á^ ~ á ] ^áÁ) áç | | | ^!  
æ) á \* Áá çæ \* Áæ) á Áá | | , Á [ çæ \* Á^ çæ | ÁÚT XD  
^| à | \ { Á) çæ çæ ^ Áæ | Áçæ á | Á: | { Áç^ Á^ æ Á ~  
ç@ Á) á | Á [ • ç^ædq | ç Áçæ ^ Áá ~ ^ | ^ ) ç^ çæ \* Áç |  
| | ^!ææj \* Áæ) á Áçæ • | | | çæ \* Áá çæ \* ÁÁ ^ Á | Áç Áç@  
dædq | Á | | ^!æj | ç Áç) æ ~ æ Á | Á ^ • á \* Áç @ Áçædq | ç  
| á @ Á , áæ çæ) á Á ] ^!ææj \* Áç @ Áç | ) Á á) æ • Á

OPS-B- 0017Á



OPERATION

Ó | {

U] ^!ææj } Á^ & ç } Á H

# OPERATION

## 2.4 Tractor Ballast

When the boom is fully extended, the tractor must be on level ground. The counterweight must be lowered to the ground to ensure stability. The tractor must be on level ground when the boom is fully extended. The counterweight must be lowered to the ground to ensure stability. The tractor must be on level ground when the boom is fully extended. The counterweight must be lowered to the ground to ensure stability.

OPERATION

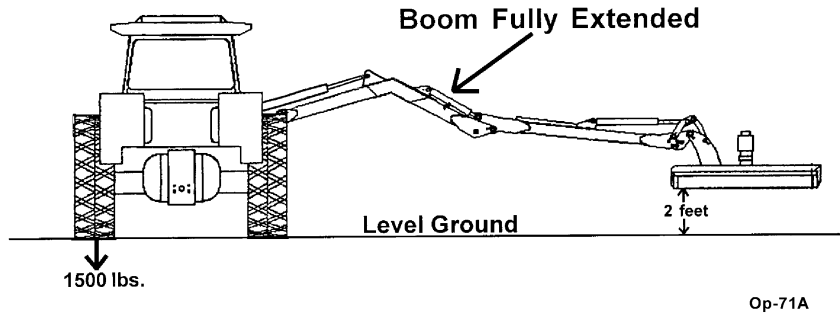

The tractor must be on level ground when the boom is fully extended. The counterweight must be lowered to the ground to ensure stability. The tractor must be on level ground when the boom is fully extended. The counterweight must be lowered to the ground to ensure stability.

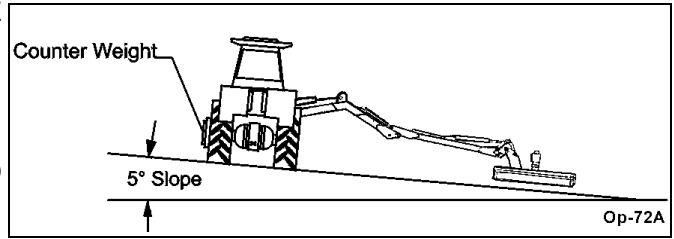

## 3. GETTING ON AND OFF THE TRACTOR

When getting on and off the tractor, the operator must use proper safety techniques. The operator must use proper safety techniques when getting on and off the tractor. The operator must use proper safety techniques when getting on and off the tractor.

**WARNING**

When getting on and off the tractor, the operator must use proper safety techniques. The operator must use proper safety techniques when getting on and off the tractor. The operator must use proper safety techniques when getting on and off the tractor.





# OPERATION

OPERATION

## 4. STARTING THE TRACTOR

V@Á ] ^iæ |Á ~ • Á@æ^Áæ [ ] | ^Á } á^i • æ ää \* Á -Á@Á |æ { ^ } &ç } Èæ äÁ ] ^iææ } æÁ • ^Á -Áæ | dæç | Áæ | d | • Á^ - | ^Á æç \* Á@Áæç | ÈÁ^ç ä, Á@Áæç | Á ] ^iæ | ç Á æ ~ æÁæ äÁæ | • | çæ Áæ ç | ä^á ä^æ | Á | Áæç | Á ] ^iææ } / • d ~ &ç } • Á^ ^á^áÉ

Ö • ^ } æÁæç | Á | d | • K

- " S | æ Á@Áæ } äæ } Á^ É, æ&@
- " S | æ Á@Áæ } \* ä^Á @ ç -Áæ | d |
- " S | æ Á@Áæ | äæ | æÁæ | d | | Á^ç^i • Á
- " S | æ Á@Áæ @Áæ } d | | Á^ç^i
- " S | æ Á@Áæ | äæ^Á^áæ çæ äÁæ ç &@
- " S | æ Á@Áæ VUÁæ | d | | Á
- " S | æ Á@Áæ | äæ | ç Áæç | d | | Á^ç^i
- " S | æ Á@Áæ | Á | Á^iææ \* Áæ | d | | Á^ç^i • æ Á | Áæç^Áæ | D

Ö - | ^Áæç \* Á@Áæç | Á } • | ^Á@Áæ | | | , ä \* Áæ

- " Ö | ä ~ &ç | Á | Áæç | ^iææ } / • | ^Áæç } Áæ äÁ^çæ Áæç | ää \* Á Á@Áæç | Á ] ^iæ | ç Á æ ~ æÁæ
- " T æ^Á ~ | ^Áæç^i æ ä • È ç | ä • Èæ äÁ ç | Á æ^ç Á^çæ • Áæ^Á^æ | ^ | / Áæ É
- " V@Áæ ä ä \* Áæ^Áæ | È
- " V@Áæç | Áææ { ä • ä } Á^ç^i • Áæ^Áæ | Á^ dæç
- " V@Áæ [ | Á ] ^iææ \* Áæ | d | | Áæ^Áæ | Á^ dæç äÁ -Á | • äæ } É
- " V@Áæ VUÁæ | d | | Á^ç^i | Áæ^Áæ } \* æ^áÉ
- " V@Áæ äæ | æÁæ { | Áæ } d | | Á^ç^i • Áæ^Áæ | Á^ dæç | • äæ } È

Ü^ - | Á Á@Áæç | Á , } ^i ç Á æ ~ æÁæ | Áæç \* Á | &á^ | ^ • ÈÁ | | ^ Áæç | Á@Áæç | Á @Á^æ^áæ ä ä^á^áæ Á@Áæç | Á ] ^iæ | ç Áæç | Á^ç^i | Á^ æ • Á@Áæ } äæ } Á, æ&@ Á @ | ç &æ äæ \* Á@Áæç | Á | | [ äæ | Öæ | Á@Áæç | Á } \* ä^Áæ } } ä \* Èæç | ä Áæç^i } æç } çæç, æ@Áæç | Áææ { ä • ä } Áæ | Á^ç^i ç^ äá } æ äÁ } ^ç | ^ ç^áæç | Á [ ç^ { ^ } ÈÁ OPS-B- 0003



Á^ç^i | Á^ } Á@Áæç | Á } \* ä^Áæ Áæç | • Áæ^ ää ä \* Á | Á æç ~ çæç^ æ^ç^ } çæç } ÈÁ @ Á^ç^i • Á { ^ • Áæç Á^Áæ æä | ~ • Áæ | Á^ | Áæç | Á^ç^i



Üæç | Áæç | Á } | Á @ } Á | | | | Á^æ^áæ Á@Áæç | Á^æç | Áæç \* Áæ çæç | Áæ Á^æç^i Á^ • | çæ | Áæ | Á^æç | Áæç | Á ] ^iæ | • { æ ~ æÁæ | Á | | | ^iææç \* / • d ~ &ç } • ÈÁ



Ö | { U ] ^iææ } Á^ &ç } Áæ

# OPERATION

OPERATION

## 5. CONNECTING ATTACHING HEADS TO THE BOOM

FEÁÚ cæóÁ` Áææ&@ \* Á@Á æç | óÁ:æ& ^ ÇDÁ Á@ÁÀ [ { ÇD  
 ~•á \* Á ç ÇDæ áÁ@æá, æ^ÉÁ^ ÇDæ&@@& |á á^Á Á@  
 ] æç | óÁ:æ& ^ ÇDÁ •á \* Á ç ÇDæ áÁ | Á á •É

ÇÁV@ } Áææ&@@Á | \* | ÇDÁ Á@Á [ , ^ ÇDÁ •á \* Á ç ÇD  
 æ áÁ@æá, æ^É

HÉV^ ÁæÁ@ á Á Á | ^ Á@Á [ { ÇDÁ [ } Á Á@Á [ , ^ ÇDÉ  
 Ç • Á Á@Á ] ] Á ç ÇD@ ~ @ Á) á Á Á@Á [ { Áæ áÁ@  
 { [ , ^ Áæ&@, æ@æá, æ^É

Í ÉV@ } Áæá } Á@Á | \* | ÇDæ áÁ@Á æç | óÁ:æ& ^ ÇDÁæ&@  
 , æ@ ç ÇDæ áÁ@æá, æ^É

Í ÉÇ æç Á æ^Á ^ ÁæÁ | ÇÉ ~ ÇÉ á Á ç • Áæ^Á @ } ^ Á Á  
 ^ Á & { { ^ } á á Á | ^ Á OPS-B-0004\_D

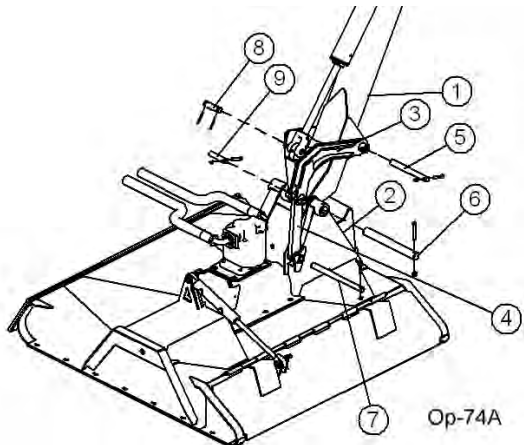

ÇÉ [ æ& } æ&@ æ@Ç Á ^ Áæ^ Á ç & } á ç \* Á@ á æ | æ Á ç Áæ \ • É ] { } É [ ç | É ç æ ç ^ Áæ á  
 Ç • Á Á } ^ & ç } ÉÚ | ç Á@ á æ | æ Á | • • ^ Áæ ^ | ^ Á | ^ | { á \* Á æ ç } æ & Á | Á ^ } æ • É  
 W^ Á [ ç • Áæ á Á ^ Á | ç & ç } Á @ } Á | ç æ ç \* Á ç Á { } [ ] ^ } ÉÚ [ } æ&@ æ@Ç Á ^ Áæ  
 [ Á ^ æ Áæ } Áæ^ Á | ç ~ Á ç | Á [ { Á } • Á | Á & ç á ç \* ÉÚ É D



Ö | Á [ Á ] ^ Áæ Á@ ÁÖ ~ ç { ^ } ç æ@ á æ | æ Á ç Á | Á ^ Áæ á ç \* ÉÚ ç  
 æ á Á ^ Áæ^ Á ç ] [ • ç Áæ á Á@ á Á | Á • } & Á | | á Á | Á • } ç æ æ á ÉÚ  
 } [ Á & @ & Á | Á ^ æ • Á æ@ [ ^ Áæ á Á ç Á @ ] ^ • • ^ Á ç á d ^ æ • Á | {  
 á | á æ • Á Á@ Á ç ^ Á | | á Á ^ } ^ d æ Á@ Á | ç Áæ á Áæ • Áæ • ^ Áæ æ ^ Á  
 ç & } á ç \* Á ç \* Á ^ Á ÉÚ Á & @ & Á | Á ç • Á ç ÉÚ P W Á @ Á } æ Ö P Ö Ç Ö  
 U Ç Ç Á á Á [ [ ç Á Á@ á æ | æ Á | • • ^ Áæ ^ æ á ç Á ] ^ } ^ d æ | Á [ ç • É  
 • æ ç Á | æ • Á ç á Á ^ Á ç á á | æ á Á Á & @ & Á | Á ç æ ^ } & Á - Á ç á æ • ÉÚ  
 ^ [ ^ • ] ^ Á ç æ ÉÚ Ö T U X Ö Á @ Á P U U Ö Á ç á Á ç ^ Á ç • ç á Áæ Á ç Á É  
 Ç Á ç Á [ ^ Á ^ } ^ d æ Á@ Á | ç É Ç Á@ Á ç | Á ^ æ á Á { ^ á æ | Á Á æ  
 ] @ • æ á Á [ , | Á ^ á æ | Á ç á Á | á Á Á ç Á | [ & á ^ Áæ É D



## 6. PRE-OPERATION INSPECTION AND SERVICE

Ó ^ | ^ Á æ & Á • ÉÚ | Á É ] | æ æ } Á ç • ] ^ & ç } Á ç á Á | ç æ Á Á @ Á ] | ^ } ^ ó æ á Á ç æ ç | Á ^ • ó Á Á | ^ | { ^ á É  
 V Ç Á ç & } á • Á | ç Á æ ç } æ & Á ç á Á & @ á | á Á | á æ æ } ÉÚ • ] ^ & ç \* Á@ æ ç | Á ç ç Á ç Á ç Áæ^ Á ~ ç ] á  
 æ á Á ^ } & ç } æ É æ á Á | ^ | { á \* Á ^ á á Á ^ } æ • ÉÚ Ö Á P U V Á ] | æ Á@ Á } á Á@ Á | Á É ] | æ æ } Á ç • ] ^ & ç }  
 ^ ç æ ç Á ç ^ Á | á á } Áæ^ Á ç \* Á æ Á ] | æ æ } ÉÚ | ^ | { Á ^ } æ • Á ç á Á | æ ^ { ^ } ç Áæ æ á Á ç á Á ç • á \*  
 ] æ ç Á Á [ ] Á Á [ ç Á æ ÉÚ Á | ^ | { á \* Á ç | ^ } ^ Á É ] | æ æ } Á ç • ] ^ & ç } Á ç á Á | ç æ ç æ | Á Á [ , } Áæ ^  
 æ á Á ^ } æ Á | • ÉÚ Á Á æ [ æ á É OPS-U-0029

Ö [ { U ] | æ æ } Á ^ & ç } Á É

# OPERATION

OPERATION

## WARNING

U^l q a a b e f A q . ^ & A a f A [ q a \* A ] a e o A f i A , ^ a a a q a a i ^ | a a A , @ } ^ & . . a a A a o a e o q i a a a A i c a a A a o E A S [ \ A f i A [ . ^ A a e o ^ a i . E a [ i ] [ i A a i \ ^ ) A j a e o E a q a A a e ^ A f i A [ . ^ A a a a \* E A T a a ^ A ^ i ^ A a f i A j . A o e ^ a a a a \* A o a a , a e ^ E A U i a ~ ^ a b i ^ A a e A & i A i { A [ o f a a a a \* A o e { a e o ^ a a A [ i a A [ i \ a \* A i a a i E A U o e f e D

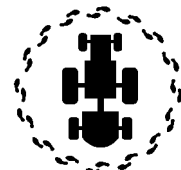

## DANGER

O f i U a e c A U @ j a . E A O ^ a a . A a q a A U a e c A a ^ c a . a & i a a \* A G a ^ o y [ c j a a a a q D E a o A O ^ i & q i . E A O a a A O ^ a a . E U e ^ i A O ^ a a . E A O ^ a a i c U @ j a . E U V U A q e i a A @ j a . E a q a A U ^ c a e a e ^ A O [ i A U @ j a . A a q i a a ^ . ^ a a a q a A f a a a a a A a A [ i a A [ i \ a \* A & i } a a a } E A O f i A e c A a ^ c a . A @ ^ i a A a a . ^ & e a a a e a e ~ | i a e a e o a a a A f i A a . a \* A i a i \ ^ ) & i { [ i ] ^ ) o E A T a . a \* E a i \ ^ ) E [ i A a [ i ] A a { . A ^ . o a A A } | a a a a a } & A f i A a ^ & A o A [ . . . a a a A a b i ^ A i a a e o + [ { A o [ , } A a b o E a } a a \* i ^ ^ ) e A i A i a a a & i } a e e A U o t e D

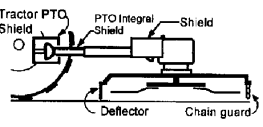

### 6.1 Tractor Pre-Operation Inspection/Service

U ^ a i A f A o a a a a d i A j a i a a i q A a q ^ a a f i A . ^ i ^ a e & i [ ] i ^ e A i ^ e i j a i a a a } A q . ^ & q } A a a a & @ a ^ i a . ^ i c a a A a a i ^ i { a a a a a & i i a a \* A q a o { a q ^ a e o i ^ . A i ^ e i { { ^ } a a a a } . E A V @ A f i i i . q \* a a A [ { ^ A . A o a e { . A o e A ^ ~ a a a a a A i c a a A a a a } ^ & q } K



Op-13

- " V a ^ A i } a a a } E a A i ^ . . ^ i ^
- " Y @ ^ i A ^ \* A i | o A
- " U e a i q \* A q \ a e ^
- " U V U A @ j a A
- " U T X A a } A a i ^ a q a e a a A c a a i ^
- " V a e d i q A a @ a e a A i a e a e a a } & q } a
- " V a e d i A U a e a i o e A A [ i a A i } a a a } A
- " V a e d i A U U U U A a A [ i a A i } a a a }
- " U U U U A a A o A a e a a A [ . a a }
- " E [ A a e d i A a q a a e . A
- " U a a a e i A i ^ A A i a i a A
- " O ) \* a ^ A a q a c a i a e a a i } a a a }
- " O ) \* a ^ A i [ i e o f c a i a e a a i } a a a } A
- " U [ , A i a i a e a A i a a q a i A
- " U [ , A i A e a i q \* A i a a q a i A
- " O ^ A i A i } a a a } a e a a q a i A
- " U ~ a a } o f a i a e a a } a e a A i a a A [ a o
- " O a A a c A i A i } a a a } A O P S - U - 0 0 3 0

O [ { U j a i a a } A i ^ & q } A i i e



# OPERATION

## 6.2 Boom Unit Pre-Operation Inspection and Service

Q • ] ^ & o & ] a a ^ i c a A c @ A a [ [ { A e { A e a a @ a a A ] a ] A t A ] ^ i a a } E A O a e e a a A e a p i A a [ \ ^ } A j e o A @ ~ i a A a ^ i ^ } a a A e a e a p i A ^ } i a a A a { ^ a a e i E A A V A } ~ i ^ A c @ A ~ } a a A ^ a a ^ A t i A ] ^ i a a } E A } a ~ & o A c A t I I , a \* K OPS-B- 0020A



U ^ i a a a e a A a ] ^ & o A e A [ c a \* A ] e o A t i A , ^ e a a e a a i ^ } i a A , @ } ^ & o o e a A a o e o i a a ^ a A i c a A } e o E A } [ \ A t i A [ [ . ^ A e o } ^ i . E A [ i ] [ i A a [ \ ^ } A j e o E a e a A ^ a e A t i A [ [ . ^ A a a \* . E A T e a ^ A ~ i ^ A e a A ] a . A c @ e a e a e o \* A c e a , e a E A A i a ~ . a b i ^ A e a A & i A t [ { A [ o i a e a a a \* A c @ } e a o / a a A [ [ a A [ i \ a \* A i a i E A O E F O E

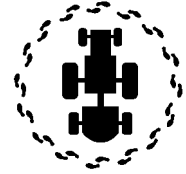

OPERATION

V @ A ] ^ i a a i q A e a e a a e a c A a } . A e a a a A } o @ A ~ } a a e { } e a A a ] [ i e a o a d ~ & e } . A } A c @ A e a e a A i [ ] ^ i A . ^ A . A c @ A ~ a { \ } e A T e a e A c o . ^ a [ [ i e a o a e a c A e a i . ^ A } A c @ A ] \ ^ } o a A [ [ a & ] a a e } A t A } . i ^ A c @ A t i { e a } A a A e a e a A t c @ A ] ^ i a a i a e a A a . ^ E



Op-14

~ O ) ~ i ^ A a A e a c A a } . A e a a A ] a e a e a a A \* a i E A U ^ } i a a A a ~ a \* E a e e a a i a a / \* a i A a ^ & a e E A OPS-U- 0011\_A

### o u e f o a e u o t o s y

- " Q • ] ^ & o & ] a a a } A A [ ~ } e \* A e a A ^ i a { \ } e
- " Q • ] ^ & o & ] a a a } A A , e A i A e . ^ E
- " O ) ~ i ^ A a A [ o A e a A & i . A e a a A [ . a a } a a a e a A i [ ] ^ i A i ~ ^ a e
- " O ) ~ i ^ A a A a . A e a a A ] a e a e a a e o } ^ a A a o A . & i . ^ E
- " O ) ~ i ^ A a e a a A i [ ] ^ i A [ ~ } e a a e A a e d i A a e a A c e a , e a a A i [ ] ^ i A . e a i a a e a a a e a } ^ a E OPS-B- 0021\_D









# OPERATION

OPERATION

050654P 0000AD U000V0P

- " Q•] ^&06|æ^•Áæ á6|æ^6[ |0 Á; Á [ •^ ) ^••Á æ áÁç&••æ^Á^ æ6U[ æ6 Á€æ Á æ^Á; Á &@& á \*Áæ á^Á^|æ^6æ æ^á6 [ ] 6æ áÁ { á•á \*6|æ^•Áæ Á [ ] |^Á^0 Á Á ææ Á &^••@ææææ &É
- " Ö)•^Á^ áá^Á^+&ç;•Áæ^Á Á [ •ææ } Áæ áÁ [ |ææ æ^á6U[ |æ^Á [ ] 6æ | \^ ) 6æ áÁ { á•á \*Á^&ç } •Á { ^áæ^É
- " Ö)•^Á^Á [ | | •Áæ^Á Á [ [ áÁ } áææ } Áæ áÁ | | æ^Á^+É
- " Q•] ^&06|æ^6[ |0 Áæ áÁ&^, •Áæ^Á Á [ •ææ } Á æ áÁæ^Á [ ] | | Á; ^~^áÉ
- " Ö)•^Á^áæ |æ^Á^•Áæ^Á [ ] | | Á; } ^&ç áÁ ç Á@Á@áæ |æ^Á [ ç | 6@& Á; Á@áæ |æ^Á^æ •Áç \*Áç •Áæ áÁææ \*ÉÖUÁUVÁ•Á^ [ ^ Áæ áÁ &@& Á; Á; Á; áæ •ÉÁ^Áæ áÁ &Á [ Áæ^ Á; á; Á; Áæáá[ æáÁ &@& Á; Á @áæ |æ^Á; áæ •É
- " Q•] ^&06|æ^6[ ] áææ } Á -Á@6|æ^Á^0É
- " Ö)•^Á^Á; áæ^Á^0Á @|á •Áæ^Á Á |æ^Áæ áÁ á Á [ [ áÁ^ ] æÉ
- " Ú\ [ ç^ Á; áæ^Á; @|Á^á; Á; ç; áÁ áÁ; á; ^áæ [ ^ ] áÁ@&^••@æ^Á; áÉ
- " Q•] ^&06|æ^6[ ] áææ } Á -Á&Á |æ^Á; áÁ @æá, æ^ÁOPS-B- 0026\_B



**▲ DANGER**

Ö| Á [ ç^ Á; áæ^Á; áÁ^Á [ , ^Á&•ÉÖæ^Á [ ] æ&ç Á^• | ç áÁ^á^•Áç^ ÁææÖUæ Áæ æÁ; çÁ; Á [ ç } Á@Á ç ] ] ^á æ áÁ@Á&•Áæ^Á&^ | | Á; [ &^áÁ ] ÉÁææ



**▲ DANGER**

ÖÁUæç ÁU@|á •ÉÖ~ æá•Áæ áÁ [ ç^Á; æç Ááçæ^Á; &ç áá \*Áç^ ç) [ ç] áæ áÁç DÁÉ Ö-+&ç; •ÉÖç^ÁÖ~ æá•Áæ áÁÖæá [ çÁU@|á •Á; ^•óá^Á^•^áæ áÁ; ææ áÁá; Á [ [ á , [ | \^ \*Á; ] áææ } ÉÖÖÁæç Áçæ^Á @ | áÁ^Á •^&ç áÁææ~ | | Áææææ Á; Á; á•á \* [ | Á; | \^ ) Á; [ ] ] ^) •ÉÁ á•á \* ÉÁ | \^ ) ÉÁ | Á; [ ] Á; { •Á; ^•óá^Á^ |æ^Ááæ } &Á; Á^á & @Á [ ••ææç Á; Á; á; Á; Áæç [ Á@, ] Á á@& ÉÁ } ç; | \^ ) ÉÁ | Á; áÁ; } æÖÁ

Ö| { U | áææ } Á^&ç } Á; É

# OPERATION

OPERATION

## 6.3 Cutting Component Inspection

OPS-U-0031

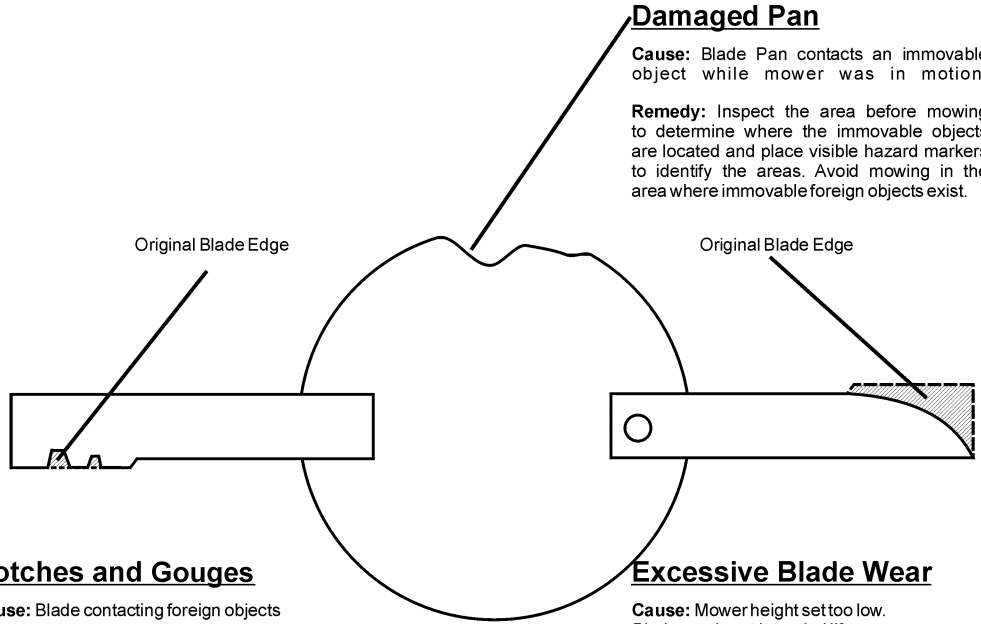

### Notches and Gouges

**Cause:** Blade contacting foreign objects

**Remedy:** Inspect the area to be mowed and remove foreign objects that could cause damage to the blades

### Excessive Blade Wear

**Cause:** Mower height set too low. Blade used past intended life.

**Remedy:** Replace blades more often. Adjust mower height for mowing conditions to eliminate blade-to-ground contact

Op-22



**DANGER** Read and understand the operator's manual before operating the mower. Failure to follow the instructions could result in injury or death.

- " 0 1 2 3 4 5 6 7 8 9 10 11 12 13 14 15 16 17 18 19 20 21 22 23 24 25 26 27 28 29 30 31 32 33 34 35 36 37 38 39 40 41 42 43 44 45 46 47 48 49 50 51 52 53 54 55 56 57 58 59 60 61 62 63 64 65 66 67 68 69 70 71 72 73 74 75 76 77 78 79 80 81 82 83 84 85 86 87 88 89 90 91 92 93 94 95 96 97 98 99 100

OPS-U-0032

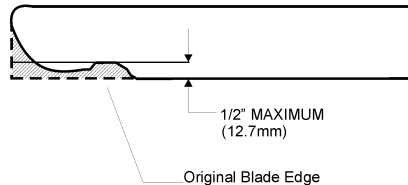

**NOTE:** Replace Blades in pairs after no more than 1/2" (12.7mm) wear  
Op-23

U 1 2 3 4 5 6 7 8 9 10 11 12 13 14 15 16 17 18 19 20 21 22 23 24 25 26 27 28 29 30 31 32 33 34 35 36 37 38 39 40 41 42 43 44 45 46 47 48 49 50 51 52 53 54 55 56 57 58 59 60 61 62 63 64 65 66 67 68 69 70 71 72 73 74 75 76 77 78 79 80 81 82 83 84 85 86 87 88 89 90 91 92 93 94 95 96 97 98 99 100



# OPERATION

## Boom PRE-OPERATION Inspection



O qy gt "K %aaaaaaaaaaaaaaaa

O cmg aaaaaaaaaaaaaaaaaaaaa

F cvg<"\*\*\*\*\*"aaaaaaaaaaaaaaaa

Uj klv aaaaaaaaaaaaaaaaaaaaa



Before conducting the inspection, make sure the tractor engine is off, all rotation has stopped and the tractor is in park with the parking brake engaged. Make sure the mower is resting on the ground or securely blocked up and all hydraulic pressure has been relieved.

Table 1:

Kgo	Eqpf kklq'cv'Uctv' qh'Uj klv	Ur gekle'Eqo o gpw' kh'pqv'QCMO
Vj g'Qr gtcvt ai'O cpwcrku'lp'yj g'tcevt		
Cmluchgv 'f gecni'ctg'lp'r meg'cpf 'rgi kdr		
Vj g'o qwpv'pi 'htco g'dqnu'ctg'lp'r meg'cpf 'vi j v		
Vj g'dqgo 'eqppge'vqp'dqnu'(' r'kpu'ctg'vi j v		
Vj gtg'ctg'pq'etcemi'lp'dqgo		
Vj g'j {f tcwle'e'rdpf gtu'r'kpu'ctg'vi j v		
Vj g'j {f tcwle'r'wo r'j'que'eqppge'vqp'u'ctg'vi j v		
Vj g'j {f tcwle'xcx'g'eqpv'qnu'hp'ev'qp'r'tqr gtn'		
Vj gtg'ctg'pq'rgcn'pi 'qt'f'co ci gf'j'qugu		
Vj g'j {f tcwle'qkl'rgx'g'riku'hw		
Vj gtg'ku'pq'gxl'f'gpeg'qh'j {f tcwle'rgcm		
Vj g'drcf gu'ctg'pq'v'ej k'r'gf.'etcem'f'qt'dgpv		
Vj g'drcf g'dqnu'ctg'vi j v		
Vj g'f'gh'ge'vqtu'ctg'lp'r meg'cpf 'lp'i qaf'eqpf kklq		
Vj g'dqgo 'uj lgn'f'u'ctg'lp'r meg'cpf 'lp'i qaf'eqpf kklq		
Vj g'un'k'uj'qgu'ctg'lp'i qaf'eqpf kklq'cpf 'vi j v		
Vj gtg'ctg'pq'etcemi'qt'j'qgu'lp'dqgo 'f gem		
Vj g'j {f tcwle'o'qv't'o'qwpv'pi 'dqnu'ctg'vi j v		
Vj g'dqgo 'j'gcf'ur'lp'f'rg'j'qwu'pi 'ku'vi j v'cpf'hw'dt'le'cy'f		

Qr gtcvt ai'Uki pcwtg<

**DO NOT OPERATE an UNSAFE TRACTOR or MOWER**

Ó [ { U ] ^ ! a a } Á ^ & a } Á Ë Ì

OPERATION



# OPERATION

# OPERATION

Equipment Operation

Control panel for the boom lift, showing various functions and their corresponding controls.

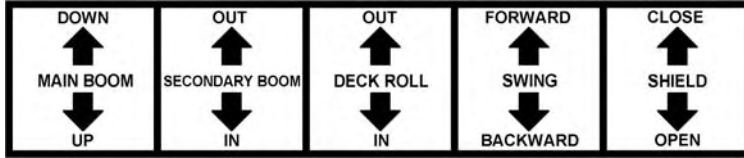
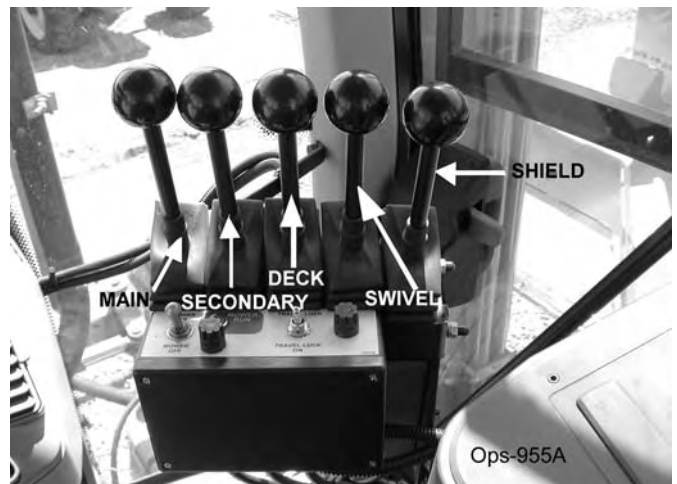
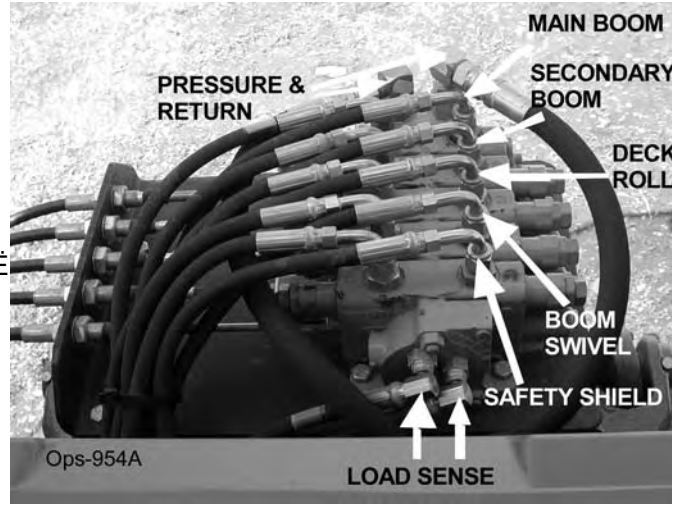

Diagram illustrating the control panel layout and the corresponding functions for the boom lift. The controls are arranged in a row, with arrows indicating the direction of movement for each function.



Control

Panel

# OPERATION

OPERATION

## 6.4 Switchbox

V@ÁÛæc ÁÛ@|áÁç^iÁ ] ^} • Áæ á&| [ • ^ • Á@Á @|á  
 || &æ áÁ } Á@Á [ ] ð Á@Á &æ æ! Á@æáÉY @) Á [ çá \*  
 æÁ! Á ^æ Á@Á! [ ~ } áÉæ, æ • Á@æ ^ Á@Á @|áÁá Á@  
 &| • ^ áÁ [ • æá } ÉY @) Á [ , á \* Áá Á@Á! ~ • @Á! Áá  
 d^ • Áæ [ çÁ! [ ~ } áÁç^iÁ@Á @|áÁ æ ÁáÁ ] ^} ^á  
 †! Áæ á! Á&æ æá \* ÉÛ^æáÁæ áÁ || , Á@Á æ } á \* Á }  
 c@Áá^ &æá @ , } Áá || , ÉÖ [ Á [ çÁ ~ } Á@Á &æ æ! Á@æá  
 á ç Á æ! æáÁæ \* ^! Á@æ Á ^áææ ^ ç! É

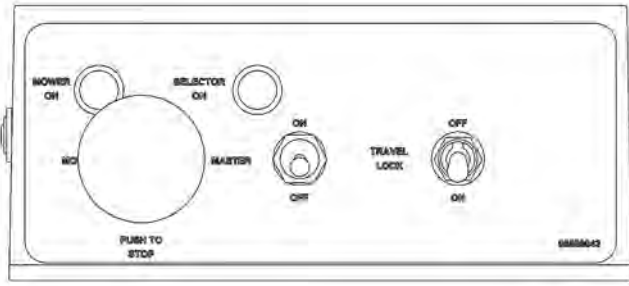



# DANGER

SAFETY SHIELD & DEFLECTOR OPERATION

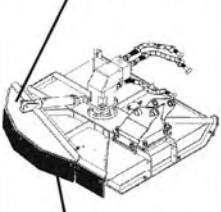
<p style="text-align: center; font-weight: bold;">SAFETY SHIELD</p>  <p style="text-align: center; font-weight: bold;">DEFLECTOR</p>	<ul style="list-style-type: none"> <li>• Failure to close Safety Shield and Deflector may allow objects to be thrown outward with great force which can cause property damage, bodily injury, or death.</li> </ul> <ol style="list-style-type: none"> <li>1. Keep Safety Shield and Deflector fully closed when cutting grass and weeds to reduce possibility of objects being thrown outward by the Blades if persons are in the area.</li> <li>2. Before Cutting brush, trimming limbs, or other such operations, raise the Deflector and Safety Shield fully to allow the blades to contact the material if area is clear of passerby. Operator must stop cutting and close shield if passerby enters the thrown objects area or blade contact area.</li> <li>3. Repair or replace Safety Shield and Deflectors as needed.</li> <li>4. Always transport with Safety Shield and Deflector closed.</li> </ol>
---	--

02967867

Ö [ { U ] ^! æá } Á ^ & ç } Á ÉÖ

# OPERATION

OPERATION

ΣΧΟΔΙΑΣΜΟΣ ΑΝΤΙΣΤΡΩΜΕΝΩΝ

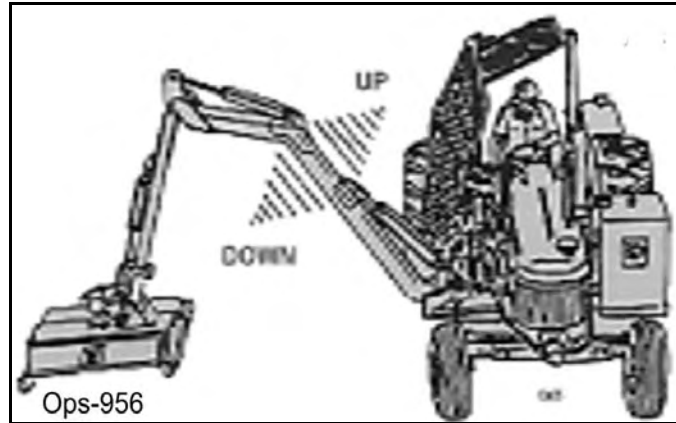

ΣΧΟΔΙΑΣΜΟΣ ΑΝΤΙΣΤΡΩΜΕΝΩΝ ΠΡΟΣΤΡΩΜΕΝΩΝ

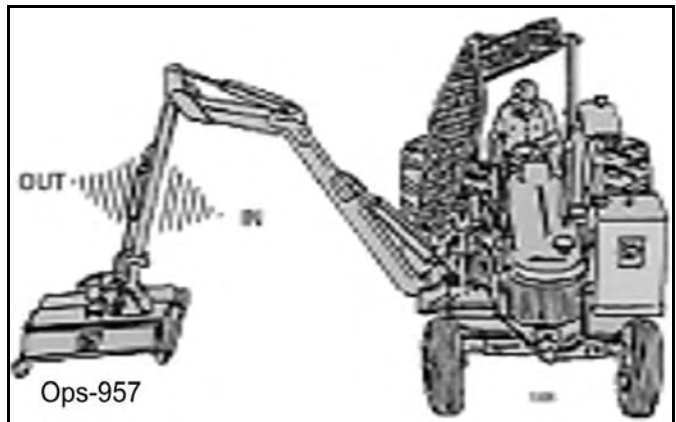

ΣΧΟΔΙΑΣΜΟΣ ΑΝΤΙΣΤΡΩΜΕΝΩΝ ΣΤΡΩΜΕΝΩΝ

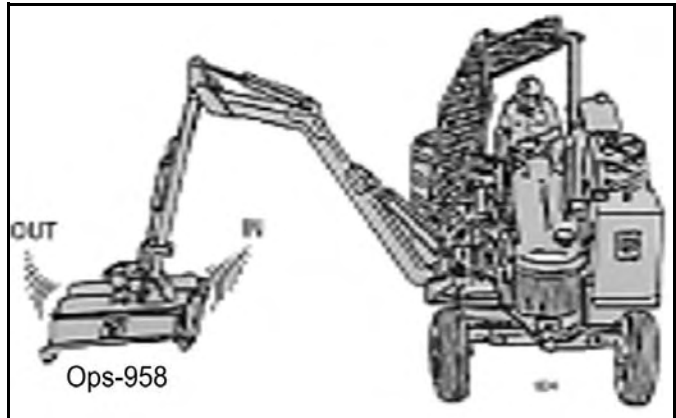

Όλες οι

υποδείξεις είναι σε ισχύ.

# OPERATION

OPERATION

ΣΧΟΛΙΑΙ ΑΟΥΤ ΑΥ ΑΟΣ

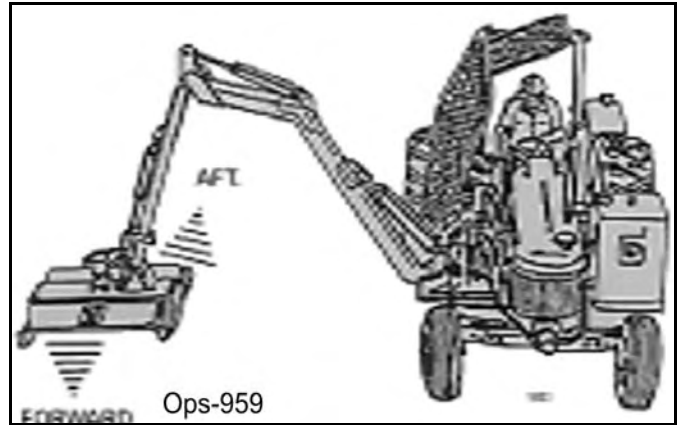

ΣΧΟΛΙΑΙ ΑΟΥΤ ΑΥ ΠΟΣ

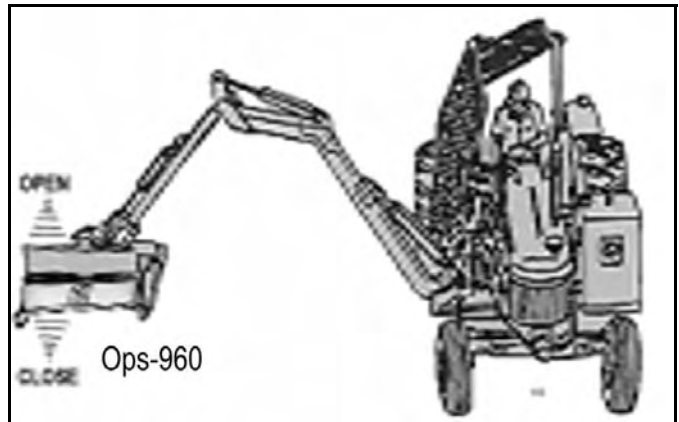

Ó[ {

U] ^! aā } Á^ &ā } ÁEGG

# OPERATION

OPERATION

## 7. Joystick Controlled Mowers

**WARNING**

DO NOT operate the mower with the boom raised or the deck roll engaged. The boom and deck roll can move unexpectedly and cause injury.

When operating the mower, the boom and deck roll can move unexpectedly and cause injury. Always use proper operation techniques and safety procedures.

**CAUTION**

Always use proper operation techniques and safety procedures. Do not touch the boom or deck roll when the mower is in operation.

**CAUTION**

DO NOT touch the boom or deck roll when the mower is in operation.

Always use proper operation techniques and safety procedures. Do not touch the boom or deck roll when the mower is in operation.

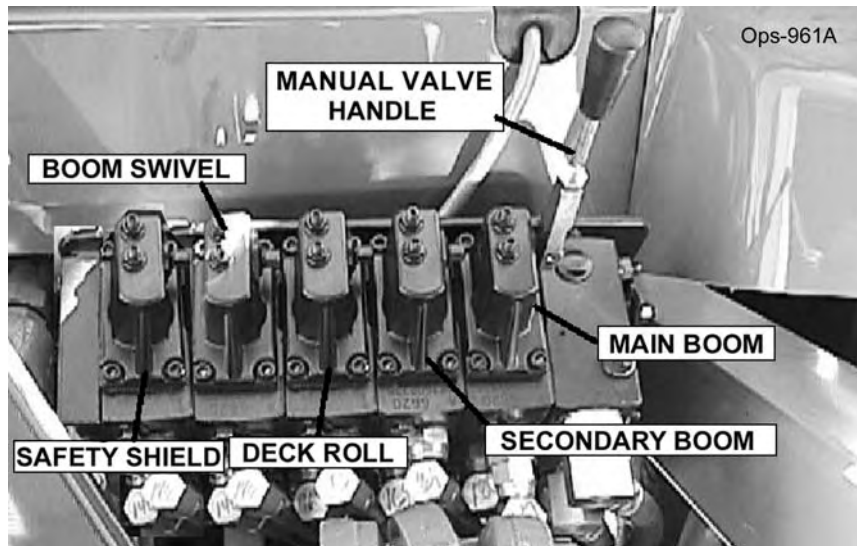

Ó[[{

U] ^!ææ } Á^&ç } ÁÈÇ



# OPERATION

OPERATION

## Joystick Control

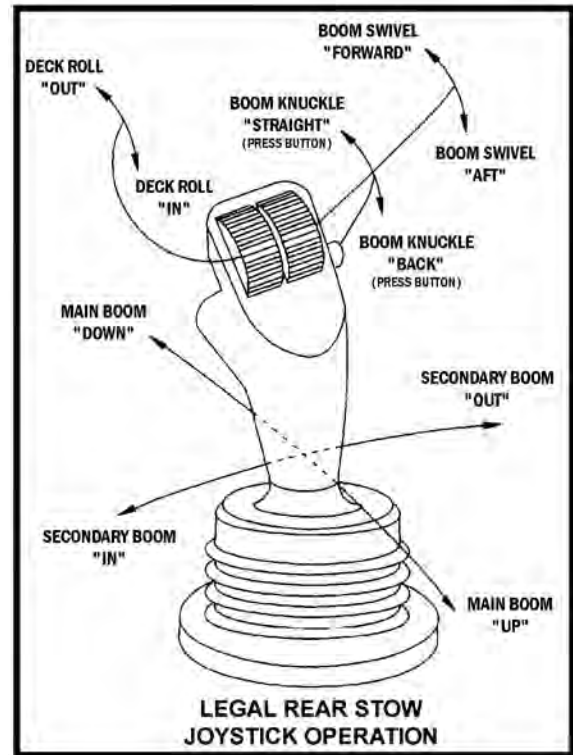
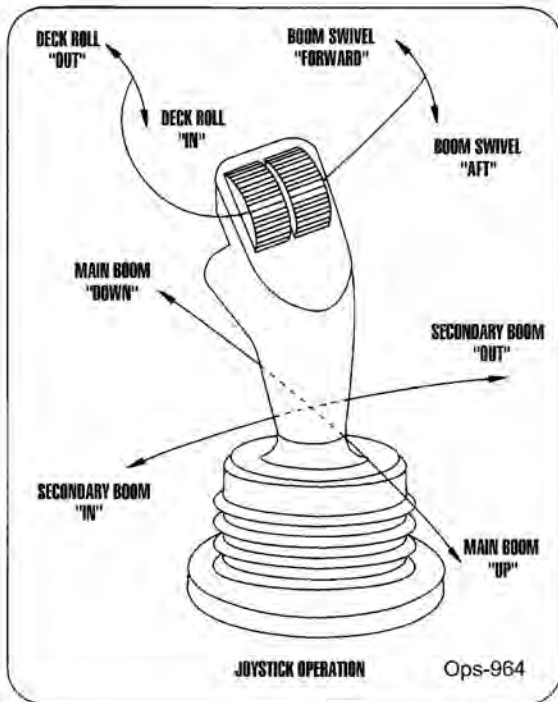

RUÿÙVÔSÁÏ ÖÖÔSÁ UXÒÚÁ ÖPÁÓUT

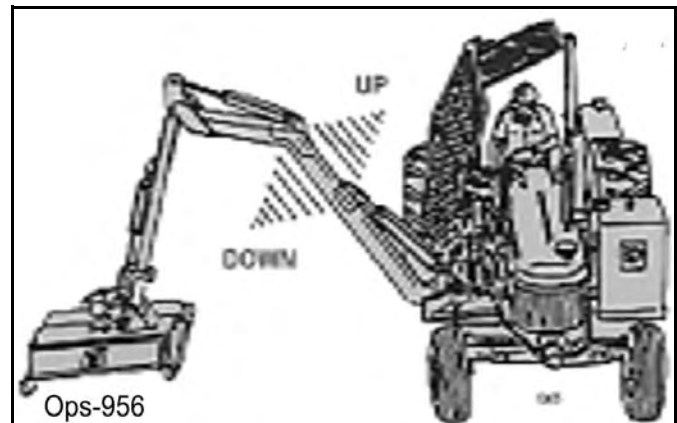

Ó[[{

U] ^! aã } Á^ &ã } ÁÉÉ

# OPERATION

OPERATION

RU'YUV@S@S@ZV@P V@T UX@U@U@O@U@P@O@Y' @UUT

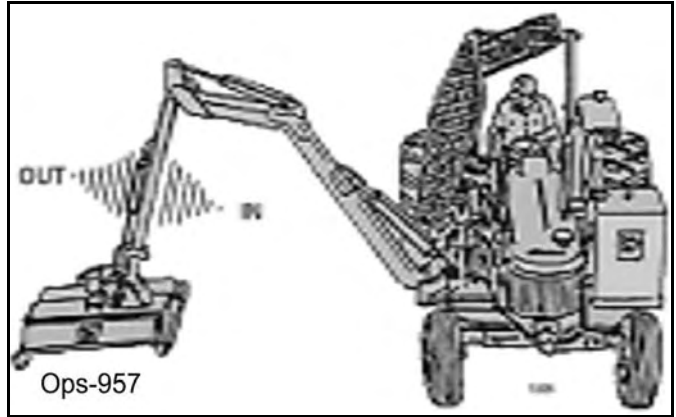

S@ZV@RU'YUV@S@U@S@S@U@T UX@U@U@O@O@S@U@S@S

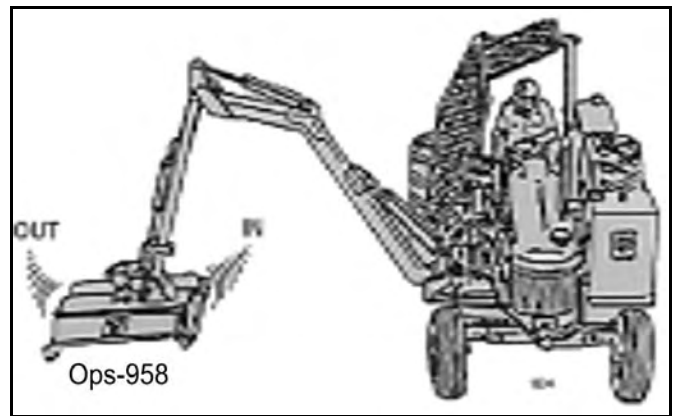

U@P V@ RU'YUV@S@U@S@S@U@T UX@U@U@O@U@U@T @ @UUT @Y @O@S

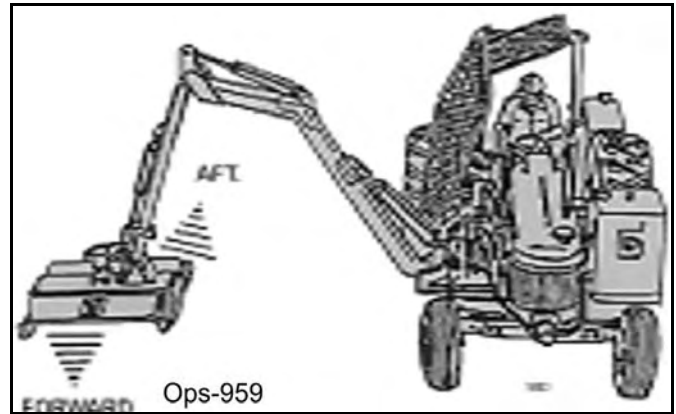

U@P V@

U@P V@ U@P V@ U@P V@



# OPERATION

OPERATION

ÜÖPVARUJYÜVÖSÄÜSSÖ ÜÄY PÖÖÁÜÖ ÜÜÖÖ ÖWVUPÁT UXÖÜÁÜUT ÁBPWÖSSÖÁUPÁÖSÖÖCS ÜÖÖÜÁVUY ÁÜUT

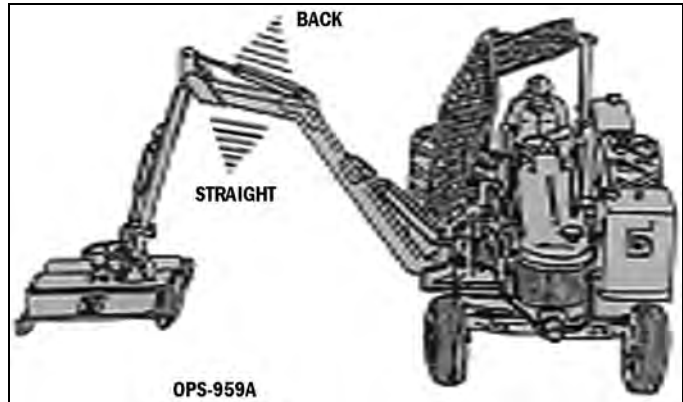

ÜPÖSÖÁ ÜY ÖÖPÖ } Á•, ä&Á à[ ÖDÁ UÜÖÜÖVÖÜ ÜÖÖÖVYÁUPÖSÖ

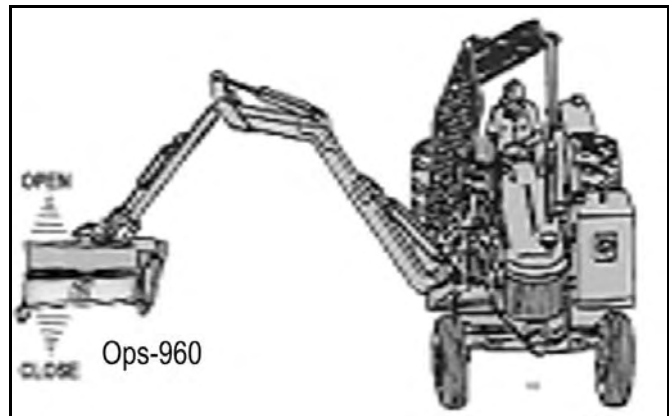

## 8.DRIVING THE TRACTOR AND IMPLEMENT

Üæ^Átæd [Átæ • ] [ :ö^~ ä•Á@Á ] ^iæf !Át Á [ ••••Áæö [ ~ \* @Á ] [ , |á^Á -Á@Á [ á^Áá \* Á ] ^iæ^á æ } áÁ ^æ ç } •Át Áæ^Á @^Ááá \* Á ä@á Áææ&@áÁ ] |{ ^ } ÖÖ) • ^Á@Átæd !Á@ Á@Áææ ææc Át @æ á^Á@Á ^á @Á -Á@Á [ { Áæ á@Átæd !Á ] ^iææ \* Á& } d [ •Áæ^Á^Át !Áæ^Átæ • ] [ ÖÖM Á ] • ^Áæc , @^Ááá \* Á@Átæd !Á ä@á [ { ÖÖçá, Á@Átæ , á \* É

Ü^æÁtæd [Átæ • ] [ :ö^~ ä•Á@Á ] ^iæf !Át Á [ ••••Áæö [ ~ \* @Á ] [ , |á^Á -Á@Á [ á^Áá \* Á ] ^iæ^á æ } áÁ ^æ ç } •Át Áæ^Á @^Ááá \* Á ä@á Áææ&@áÁ ] |{ ^ } ÖÖ) • ^Á@Átæd !Á@ Á@Áææ ææc Át @æ á^Á@Á ^á @Á -Á@Á [ { Áæ á@Átæd !Á ] ^iææ \* Á& } d [ •Áæ^Á^Át !Áæ^Átæ • ] [ ÖÖM Á ] • ^Áæc , @^Ááá \* Á@Átæd !Á ä@á [ { ÖÖçá, Á@Átæ , á \* É

S^^ Átá ^i. [ ] ÖÁ ^iÁ^Átæ Á [ , ^Áá & Áááá Áæá Á@ , Átá & Á ä@ Á^Á^Á [ &c Át Átæ } •á^iæ^á áæ ç & ÁÖÖÜÁÖSÖÖÜ ÁOPS-B- 0005

Ö [ {

U ] ^iæ } Á^ & ç } Átæ

# OPERATION

OPERATION



1. Read the operator's manual before starting the machine.   
 2. Read the manual carefully to understand the controls and safety features.   
 3. Do not drink alcohol or use drugs before operating the machine.   
 4. Do not operate the machine if you are tired or drowsy.   
 5. Do not operate the machine if you are under the influence of alcohol or drugs.   
 6. Do not operate the machine if you are taking medication that affects your ability to drive.   
 7. Do not operate the machine if you are feeling dizzy or lightheaded.   
 8. Do not operate the machine if you are feeling nervous or anxious.   
 9. Do not operate the machine if you are feeling stressed or overwhelmed.   
 10. Do not operate the machine if you are feeling any of the above symptoms.



1. Do not operate the machine on a slope greater than 15 degrees.   
 2. Do not operate the machine on a slope greater than 25 degrees.   
 3. Do not operate the machine on a slope greater than 35 degrees.   
 4. Do not operate the machine on a slope greater than 45 degrees.   
 5. Do not operate the machine on a slope greater than 55 degrees.   
 6. Do not operate the machine on a slope greater than 65 degrees.   
 7. Do not operate the machine on a slope greater than 75 degrees.   
 8. Do not operate the machine on a slope greater than 85 degrees.   
 9. Do not operate the machine on a slope greater than 95 degrees.   
 10. Do not operate the machine on a slope greater than 105 degrees.



1. Do not operate the machine with the engine running.   
 2. Do not operate the machine with the PTO engaged.   
 3. Do not operate the machine with the transmission in Park.   
 4. Do not operate the machine with the parking brake set.   
 5. Do not operate the machine with the parking brake disengaged.   
 6. Do not operate the machine with the parking brake set and the parking brake disengaged.   
 7. Do not operate the machine with the parking brake set and the parking brake disengaged.   
 8. Do not operate the machine with the parking brake set and the parking brake disengaged.   
 9. Do not operate the machine with the parking brake set and the parking brake disengaged.   
 10. Do not operate the machine with the parking brake set and the parking brake disengaged.

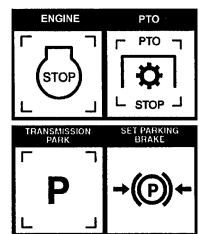







# OPERATION

OPERATION

**⚠ WARNING**

⚠ **WARNING** ⚠  
 ⚠  
 ⚠



**⚠ DANGER**

⚠ **DANGER** ⚠  
 ⚠  
 ⚠

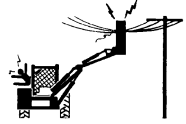

## 9. OPERATING THE BOOM UNIT AND ATTACHED HEAD

**THE OPERATOR MUST COMPLETELY UNDERSTAND HOW TO OPERATE THE TRACTOR AND MOWER AND ALL CONTROLS BEFORE ATTEMPTING TO MOW.** ⚠  
 ⚠  
 ⚠

⚠  
 ⚠  
 ⚠

⚠  
 ⚠  
 ⚠

⚠  
 ⚠  
 ⚠

**⚠ WARNING**

⚠ **WARNING** ⚠  
 ⚠

**⚠ WARNING**

⚠ **WARNING** ⚠  
 ⚠  
 ⚠  
 ⚠

⚠

⚠









# OPERATION

Q | A&#246; ca \* Ai ~ @ a a A ~ e a A ~ o d A d ] A c A c a s d | A a a A , q u A c A a [ [ { A a a A [ , ^ i A q d A q a e ^ E V @  
@ | a [ ] c a A [ . a ] } a \* A s c a } A ^ A c A a [ [ { A a A a ~ a } ^ a A d A [ . a ] } A c A &#246; c a \* A c a a A a a ] [ c a a A a a ] a a  
] | a ~ ^ i A a ] a A ~ @ } A c a ~ a . q u A | a ~ ^ i A a A } | a a A A A c A [ [ { E



**DO NOT** A ~ A c &#246; ~ a A f | &#246; A @ } A [ . a ] } a \* A &#246; c a \* A c a a A q d A c a e ^ A a a e &#246; ^ A | A c { } . E  
O a e a e ^ A f A c A } a A e A ~ | c a a A a ~ o d A d A c A c a s d a a A [ , | a e a c a e ^ A e c a \*  
t a ~ E



A Q A | a e ^ A a a | A } A d ] A ^ A [ , ^ i A a ^ &#246; A e e a \* A d a s d | A d A a ^ &#246; { ^ A } ~ a a ^ E V [ c ^ A c A a [ [ {  
% a | , a a ^ a e a a A a ~ o d A d A a ] a c a a ] a \* A ^ A c A c a s d | E S | , ^ i A [ , ^ i A a ^ &#246; A d A | ~ } a a a a A ~ c  
a [ , } A } a a e a A a A [ c a ] A d ] . E A { [ c ^ A f | a e ^ A a [ { A [ , ^ i A a ^ &#246; E

V @ A [ , ^ i A a | A ] ^ i a e ^ A [ | ^ A ~ a a } d ^ A a ~ \* @ | A | a a a } . a e a a a a o a ~ a A [ , ^ i A a c A } q u ^ A a A A ^ o ^ a e ] E  
Q c A A [ , ^ i A a ^ a ~ A d A a a e e a e d ] A c A c a s d | E S &#246; A f | A a A | a e ^ A a A c A A } a a | A | A a e a e ^ A A } q u ^ E  
Y @ } A ^ | a e a \* A } q u ^ E V | a e ^ A a | } q u ^ A , a o a ^ , A } q u ^ A d A . ~ ^ A | | ^ i A a e a e &#246; A ^ A c A [ , ^ i A a | A [ c  
c a i a e a A a c ^ i A a a a a } A a | A ~ | d e A } q u ^ A a o a } ^ ~ a a a a a a A . a e E

O \* a A a a e a A c A A } A a a A ^ A c A a ~ a e a a A [ | A [ , } A a o a a e a e } . a e c a ^ A e a e ^ V @ } a e c a \* A d ^ A a a  
. @ ^ a e A a a a | , ^ i A ^ a a | a e [ , A c A } q u ^ A a ^ A e &#246; a a | | a e A ~ | &#246; A e | a e ^ E



Q a ~ c a a a | . a e | | a e a a a a e e a a a o a c a A [ , ^ i A a a A ] ^ i a e a } A c | } A [ , ^ i A , a e a a a a o a  
a { ^ a a e a | A e e a A c a [ , } E a c ^ i A a e a A c A c a s d | A | a a [ , A ~ c a a a | A a e | | a e a a a o a **300  
FEET** A c A } a A } c a a A [ c a ] A d ] . A [ ] | ^ e ^ E

Q e c a | A c e o a e . a e a A d ] . E c | } A [ , ^ i A , a e a a a a o a a a , q u A a [ [ { A c e v e a [ | | e a A c A a s c a } A a  
&#246; a A c A e c a | A c a e a a [ c a | | A [ , ^ i A a ^ &#246; A } c a a a a a } o d A c A ^ &#246; ] a e ^ A a [ [ { E c a } A [ , ^ i A a [ [ { A d A ^ c  
{ [ , ^ i A a ^ &#246; A } A | ~ } a e a a o d A c A c a s d | E a o a a e a } a ~ a i ^ a e e a a [ , a a A [ c a ] A e A e a e e a e a } a e a a e a a  
d A a e ^ A c A c a s d | a e a a a e a c A e c a | A c a e ^ A } a e ^ E

O \* a A a e a a e a A c A A } A a a A ^ A c A a ~ a e a a A [ | A [ , } A a o a a e a e } . a e c a ^ A e a e ^ V a a e a | , A ^ a a A  
a [ , A c A e c a \* A a a a A d ^ A d A ~ | &#246; a a a | | a e a e &#246; A c A A | a e ^ E V @ } A c A a a a a a e a A a e a A a ^ } A a a e ^ E  
a a a } \* a e ^ A c A [ , ^ i A a a A a c | } A [ [ { A e a a e a a e a | A [ . a ] } E V a ^ | } A e c a \* A [ a o a a a e a ^ a o a e e  
^ a e E

O e a | A c A a . a e a e A A } ^ i a e a } E e a | | o a ~ | a a a A e a &#246; a a a e a a c a a } ^ a a ^ a e ^ i a e v a a e | a a a A a [ ^  
] ^ i a a a e a | A a } . ^ i A c A | o a | A [ o a ^ &#246; { ^ A [ . a } a a e e . ^ a a e a e ^ A e a c A c a s d | A | A [ , ^ i A a | a b i ^ A a c  
] | ^ i a e ^ E

OPERATION





# OPERATION

## 9.8 Shutting Down the Attached Head- For Standard Equipment

1. Turn the ignition key to the "OFF" position.  
 2. Turn the PTO (Power Take-Off) switch to the "STOP" position.  
 3. Turn the transmission parking brake to the "ON" position.  
 4. Turn the engine stop switch to the "STOP" position.  
 5. Turn the tractor off.



6. Turn the PTO (Power Take-Off) switch to the "STOP" position.  
 7. Turn the transmission parking brake to the "ON" position.  
 8. Turn the engine stop switch to the "STOP" position.  
 9. Turn the tractor off.



OPERATION



10. Turn the PTO (Power Take-Off) switch to the "STOP" position.  
 11. Turn the transmission parking brake to the "ON" position.  
 12. Turn the engine stop switch to the "STOP" position.  
 13. Turn the tractor off.

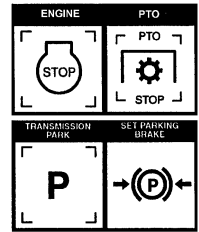

0111

U] 1111 1111 1111



# OPERATION

## 11.1 Placing Boom Arm on Boom Arm Rest - For Standard Equipment

Ó^f|^Átæ • | | çä \* Átæd | Á^ç ^ ^ } Á | &æä } • ÈÄ | Á  
 ç@ Átæd | Á } \* ä ^ Èäã^ ^ } \* æ ^ Áç@ Áæææ@ äÁ@ æäÈ  
 æ äÁ æÄ | Á | Á@ æäÁ | çä } Á | Á | { ^ Á | Áæ | { | | ^ ç  
 • d | ÈÄ | æ^ Áç@ Á | { | Á | Á • Á d | æ ^ Á | æ | Á ^ Á • ç  
 • } | | | çä äÁç@ Á | ; } Áç@ Á ^ • çä Á æ ç | Á , æ&ç |  
 ç@ Á | çä | • ää } ÈÄ



On-Off Switch

" Ü^dæçÜ^ & Á | | çä | ä ^ Á | Á | { | | ^ ç | È  
 " Ü • ç | Á | çä } äæ & | ä ^ Á | Á | ; | | çä æ | Á ÈÄ  
 , æ Ä ^ È  
 " Üææ ^ Á | æ Ä | { | | Á | | | çä æ | Á | Á ç È  
 " Ü , ä \* Á | { | | Áæä Á | , | Á } çä Á | Á dææ @ Á  
 äæä È  
 " Ç | Á | Á | | ä çä | { | | ^ ç | Á | Á | \* | Á | | { } Á  
 à | { | | ^ çä | • ää } Áç@ Á ^ çä } äæ ^ Áç@ Á  
 & ææ | È | çä ^ ~ | | Á | æä ä | çä \* Ä | Á ç | Á • È  
 " Ç | Á | Á | ^ Á d , Á ç | Á | { | | ^ çä | , Á | Áç@ Á  
 T æä Á | { | | Á | ç Á • çä ä | Á | ä \* Áç@ Á | Á | çä } äæ ^ Á  
 à | { | | Á | çä Á | Á ää \* Á | Áç@ Á | { | | ^ çä  
 " Ç | Á | Á | ^ \* ä | Á d , Á ç | Á | { | | ^ çä ^ dæç@ Á  
 • ^ çä } äæ ^ Á | Á } & | Á | çä ä ^ Á | Á | { | | ^ çä | ÈÄ  
 Š | , Á | Áç@ Á | æ Ä | { | | Á | ç Á • çä | | , | Á  
 ^ çä } äç@ Á ^ çä } äæ & | ä ^ Á | Á } çäç@ Á  
 • ^ çä } äæ ^ Á | { | | Á | çæç@ Á çä Ä | Áç@ Á | { | | ^ çä æä | È | Á çä | , | Á çä } äç@ Á ^ çä } äæ ^ Á | Á } çäç@ Á  
 çä | Á | çä } äæ ^ Á | Á } çäç@ Á | çä | Á çä | Áç@ Á | { | | ^ çä æä | È  
 V @ Á | { | | Á | Á | , Á | Áç@ Á çä } | | çä | • ää } ÈÄ | | Á | Á | çä ^ Á | Á çä } äæ ^ Á | Á | çäç@ Á , æ&ç | çä È



V | Á | { | | çä çä | Á | { | | Áç@ Á | | | Á | Á • çä • çä } Á | Á çä ^ Á | Á çä } äæ ^ Á | Á | çäç@ Á , æ&ç | çäç@ Á | Á dæç  
 çä | Á } & | Á | çä ä ^ Á | Á | | æä | Áç@ Á , ä \* Áç@ Á | Á | çä | Á | çäææ ^ Áç@ Á | æ Ä | { | | Á | | | çä æ | Á | Á  
 ä | çä • ÈÄ , ä | Áç@ Á | { | | Á | , æä Ä | Áç@ Á | ä ^ Á | • ää | ÈÄ OPS-B- 0013\_D

OPERATION





# OPERATION

OPERATION

Y @}A []^!ææ \*A []A` à|æA ![ææ·ÈA @æ^ & }·æ^!ææ } A[ !A[ @!A[ ææ·^!·ÈU` ||A[ Á@·Áæ^ [- Á@Á[ ææ·&ææ æ } æ } A[ Áæ||, Áæ|A[ ||, æ \*Áæ-æ d Áæ·ÈÖ[ Á [ Áæ·ææ·Áæ@·Áæ \*ææ ] ^áÁæ æÁ·Áæ ^ [ ^!Áæ æÁ[ Á[ ^ } ææ ææ Á[ !Áæ !æ } c |æÁææd !·È OÈ æ·Áæ ææ·Áæ @ } Áæ } [ !cæ \*Áæ@Áææd !Áæ á { [ , ^!Á[ } Á[ ^ à|æA[ ææ·ÈÖ·^ææ } Áæ Áæ·^·Áææ·È @·Áæ [ { Áæ·æ } á·Á[ Áæ @Áææ@·Áæ@ } Áæ@Áææd !· , ææ·Áæ [ Áæ·Áææ·^ |Áæ@!Áæ·Áæ [ Áæ·ææ·á·!·È [ ^·È |æ·^Á[ à·d·æ }·Á[ Áæ } Áæ·æ·Áæ·Áæ·Áæ æÁ·Áæ } æ·Áæ·Áæ [ , ^!Áæ ææ·Áæ [ { È·^·Áææ æ } Áæ á !·á· &·Á[ ^á·Áæ·Áæ@!Áæ·æ·Á[ Á[ Áæ·á·dææ·Áæ·Áæ @·Áæ·æ·È OPS-B- 0016



Op-104



DANGER: Do not operate the tractor on a slope. The tractor may tip. Always use proper tie-off technique. See the operator's manual for more information.



WARNING: Do not operate the tractor on a slope. The tractor may tip. Always use proper tie-off technique. See the operator's manual for more information.

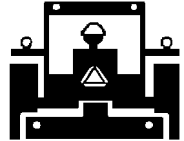

U·á· &·A[ ^á·Áæ·!·æ } æ·Á[ Áæ } [ æ \*Áæ@Áææ·È Ö·^!·Áæ·Áæ [ @·Áæ æ·Áæ·Áæ·Áæ [ &·á·Áæ·^·æ@! , @·Á[ ^!ææ \*Á[ Á[ à|æA[ ææ·È OPS-U- 0023



Op-25

Ó [ {

U ] ^!ææ } Á·^æ } Á·È H

# OPERATION

OPERATION

## 11.3 Hauling the Tractor and Implement

Ó-¦ ¡^Á¡} • ] [ ¡} \* Á} [} æ^áÁ} æ} ! Á} áÁ } | { ^ } dÉ  
{ ^æ~ ¡^Á@Á@} } @Á} áÁ} æ@} } ^} •} •} áÁ} | ••  
, ^} } @Á } Á@Á} { ] | ^Á} [} æ^áÁ} æ} } • ¡^Á@Á@  
|| æ} Á} áÁ} Á} Á} { ] | } &^Á} æ@} } ^} \* æ} Á} æ } ^Á} ^Á} !  
@ } Á} ^æ } Á} @Á} áÁ} ^Á} æ } ^Á} @ } \* @ } OPS-U- 0024



**⚠ DANGER**

Y @ } Á} } • ] [ ¡} \* Á } [ { Á } [ , ^¡Á } Á} ^ & Á } Á} æ } ! Á} @Á} } @ } Á } æ@  
{ æ } ^ } &^áÁ} ^} æ} Á} æ } Á } @ } Á} @Á} [ { Á } Á} Á} Á} @Á} } ] [ ¡ } [ • } } } É  
Ó } } } } , æ } } } ^Á } | Á } ¸¡ } @ } æ } Á } ^ } & ¸ ¡ ^Á } | Á } [ , ^¡Á } } ^ } Á} & æ } ^Á }  
] [ ] | ¡ } Á } æ } æ } ^Á } | Á } ^ } ^ } . Á } } ^Á } | Á } ^æ@ } } } ^ } } } ^ } } } Á } [ , ^¡Á } [ { Á }  
! ^á } &^Á} @ } } @ } } æ } Á } ^ } [ ¸Á } [ , } } ^ } @ } æ } Á } ^á } &^Á } æ@ } Á } @Á} ^} æ }  
| } æ } } } É

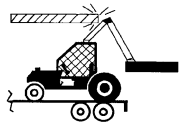

W^Á} æ^~ æ } ^Á } • ^áÁ } æ } áÁ } | æ } áÁ } dæ } ^Á } Á } æ } á  
^~ } } { ^ } Ó } Á } dæ } • ] [ ¡ } @Á } Á } æ } ! Á } áÁ } | { ^ } dÉ  
Ó } • } | } } } æ } @ } ! á } ^áÁ} æ } Á } Á } ^ } { } } ^Á } @Á } | ] | ^Á }  
^~ } } { ^ } Ó } ^~ } á } á } Á } } } ^ } ^ } ^ } æ } ^Á } ^á } ^ } @ } } • É  
@ } æ } Á } ¸ } Á } dæ } • É } } } } ^ } } æ } á } æ } á } á } • É } ^ } ^ } ^ } Á }  
á } , } Á } @Á } Á } [ ] } } } } á } ^ } } } ^Á } @Á } Á } æ } ! Á } dæ } } \* Á } @  
] [ ] | ^Á } Á } Á } [ , } } Á } & æ } } • Á } ^ } ^ } } á } ^Á } ^Á } @Á } Á } æ } !  
{ } } } æ } ¡ } ^ } OPS-U- 0025



Ó } [ { U } ^¡ } } } } Á } ^ } & } } } Á } É } |

# OPERATION

0E!æ \*^Ác@Á&@æ•Á•[Ác@æÁ, @}Áæ @^}^áÊÁc@  
 &@æ•Á æ^Á~||á \*Á[ ], æáÁ æ áÁ æ ææ•c  
 c@{•^|ç^•ÊÁæ^~||^Áæ @^}Ác@Á^&|á \*Á&@æ•Á!  
 [c@!Áææ^}^Á•Á•á \*Áá[[{^Á!Á!Ááá^}^Á!Ááá] |  
 {æá~{Á^}•á}ÊÁÁ^Á^Ác^ {^Á&æ^Á, @}  
 æææ@ \*Áæ áÁ^ {çá \*Ác@Á^&|á \*Ááçæ•Áæ Ác@  
 ^c^ {^Ác^}•á}Áá ç|ç^áÁ, @}Á!^æ^áÁæ Ác@  
 ] [ç] æáæ Áæ Áæ^Á!á~•Áæ Á!^É



Op - 48

Y @^Áæ |á \*Ác@Ácæç!Áæ áÁá ]|^ (^) æ^  
 [æææ] æ^Á•ç]•Áç Á&@& Ác@æÁc@Ácæç!Áæ á  
 á ]|^ (^) c@æ^Á [ç^áÁ!Á @æ^ááæ áÁc@æÁc@  
 •^&|á \*Á&@æ•Ác@æ^Á æææ^áÁ^}•á}ÊÁÁ!á \*  
 çá•][!c@æ^áá!æá \*Áæ @æ] Á!}á \*Á!Á, ^|çá \*  
 ææç] Á æ^Á!^|{^áÊÁç] Áæ@Á^c^æ^Á!æææ]  
 ç Áæ•] ^&Ác@Á^&|æ Á Ác@Á! æÊÁOPS-U- 0026

**CAUTION**

0ææ^Á!Á[ç^Á!^&ç^Áç^Á!ÊÁc@Á[[{Áá!Á}áÁÁ, á \*Á, æá•Ác@Á, ^Áæ^ÊÁæ^Ác@!  
 ]^Á•[}]^Áææ^Á!Á]ç|ÁÁ, á \*á \*Á [ç] Á @}Á&|á á!Á á ÁÁ^ {ç^áÊÁ æ^Á!^Ác@  
 ]^Á•[}]^Áæ^Á [ç^Á!}•á}Á!Ác@Á!Á!•@áÁ^Á, á \*á \*Á[[{ÊÁ

Ü^cæÁ, æ^Á!á á!Áæ áÁ&|Á!æ Áæ Áæ ^ÊÁç|ç^Á! [Á!, æáÁ Ác@Á}c^Á!Áææ^áÊÁ, ^Á&Á!}ç  
 c@Á!æ^Á!Á^áÊÁ áÁ @ç^Ác@Áæç|ÊÁc@Áæç!Áæ áÁc@Á [ , ^Ác@æÁ @~|áÁ [ , Á^Á&@æ^áÁ [ , }Á^&|Á!  
 ç Ác@Á!æ^Á!Á^áÊ

**CAUTION**

0æ^Áæç^Á! ^|ææ \*Á^&ç] ÊÁ!Áæ^Ác@!Á^&ç] Á!Ác@Á æ~æ^Á! [ç^Á!|^ç!  
 ~}á!•ç [áÊÁ] ææ^Á!Á!Áæ^Á!Á!Ác@Áæá!•Á] Ác@Áç^Á!Á!Ác@Á æ~æ^Á!  
 æ•ææ&^Á

0[ { U|^ææ}Á!^&ç}Á!É!

# OPERATION

OPERATION

Ó[ {

U] ^! aã } Á^ &ã } ÁÈ î

# MAINTENANCE SECTION

T aq c} a} &^Á^&cā } Á Ē



# MAINTENANCE

**WARNING**

Όλες οι εργασίες που απαιτούνται για την αντικατάσταση των υγρών ή την επίσημη συντήρηση πρέπει να γίνονται σύμφωνα με τις οδηγίες που περιλαμβάνονται στο εγχειρίδιο.

**WARNING**

Όταν αντικαταστήσετε ή καθαρίσετε τον εξοπλισμό, βεβαιωθείτε ότι οι κάμερες και οι αισθητήρες είναι καθαροί και λειτουργούν σωστά. Ακολουθήστε τις οδηγίες που περιλαμβάνονται στο εγχειρίδιο.

**DANGER**

Οι εργασίες που απαιτούνται για την αντικατάσταση των υγρών ή την επίσημη συντήρηση πρέπει να γίνονται σύμφωνα με τις οδηγίες που περιλαμβάνονται στο εγχειρίδιο.

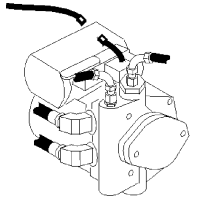

**MAINTENANCE**

Όλες οι

εργασίες που απαιτούνται για την

# MAINTENANCE

MAINTENANCE

## Regular Maintenance

V@/q c'icp ÁeÁ @&@Á\*~|æÁ^!çæq \*Á @~|áÁ^Á[ ]^Áe^Áæ^áÁ} Áq~!•Á-Á|^!æq } ÊÁV^Á@Áæq!•Áq~! { ^c!ÁÁ ÁÁ^c!{ q^Á @} Á^\*~|æÁ^!çæq \*Á Á^~á^áÈ

Ü^!Á!Áq Á@Á^c æ^áÁT æq c} æ &Á^Á&ç } Á!|Á~ @!Áq •d~ &ç } •Á| } Á^!æ q \*ÊÁÖ[ ]^Áæ q áÁ^Á@ ÁÖæq T æq c} æ &Á @^Á| ææ^áÁ@Á} áÁ-Á@Á^Á&ç } È

## Daily or Every 8 Hours

QÒT Á	ÙÒÜXÒÒ	ÔUT T ÒPVÙ
Ö!q^ÁÜ@eöÁ  \^ÊÁÈÈ q c BÁÚc àÁÜ@ec	Ö!^æ^	Ö!^æ^Áæ q •d~ &c^á/q á^æq^áÁ æq ÊÁ^Á&ç }
Ü { ] Ö!q^ÁÜ@eöÁ[ ~ ] ^!	Ö@& Áæ q áÁ~ á^	Q•^!ÁÁ!q^Á @eöÁ} áÁ ^æ
Ö!æ \ • @eöÁÈæq c!Á	Ö@& Á^ àà^!Á!  [ { ^	Ü^ æÁ^!  [ { ^ ÁÁ áæ æ^áÁ!Á ä•q *
Üq[ ÁÜ[ q •	Š~ à!ææ	Q^&Á!^æ^Á} çÁc æ ^æ•ÁeÁ} á
P^ á!æ  æÁ^çq *• Á	Ö@& Á!Á^æ•	Vá @} Á @} Á^á^á^ÁÖÖ[ Á  c^Á^Á@q á• q Á@& Á!Á^æ• ÊÁ^Á æq ÊÁÜ!^ææ ç }
S  q^•Á Á	Ö@& Á	Q•]^&Á!Á ä•q *Á!Áæ æ^áÁ} q^•È &ç *^Áe Á^á^áÈ
Ü] q á^Á [ ~ ç *Á    •] q á^Á Á&D	Ö@&	V  ~ ^Á Á+Á-çÁ• Ê~ à!ææ^á V  ~ ^Á Á!   çÁ• ÊÁ!
S  q^Á [ ~ } ç *Á    ç} q^Á Á~ Á!Á æ^ÁæD	Ö@&	Ü!^È~ à!ææ^Á@Áæ• Ê@} Á q   ~ ^Á Á €ÁçÁ•È
Ö~ \ È æ^ÁöÁ [ ~ } ç *Á    ç~ \ È æ^ÁæÁ Á] q á^ÁD	Ö@&	V  ~ ^Á Á!   çÁ• Ê~ à!ææ^á V  ~ ^Á Á!   €ÁçÁ• ÊÁ!
Ö  •	Ö@& Èæb •c	Ö@& ÁÁ! [ \^ } ÊÁ @} Áe Á^~ á^á
T æq Á!æ ^Áq áÁ Ö^Á	Ö@& Á	Ü^q   ~ ^Á     çÁ ç   ~ ^ •]^&ææq } •Á Á@Á^Á&ç }
P^ á!æ  æÁ^ çÁ~ ç^!	Ö@&	ÈááÁ^~ á^áÁ^!Á~ qÁ^Á& [ { ^ } áæq } •
Ü^æÁ æÖ!q^ÁÁ}  ææ^ÁD Ö^æÁ æ *^Áq áÁÜ@eöÁ[ ~ ] ^!	Š~ à!ææ	Ö!^æ^Áæ q •d~ &c^á/q á^æq^áÁ æq ÊÁ^Á&ç }
Ö~ c!ÁÜ@eöÁ} áÁ Ö! [ ~ } áÁÜ   ^!	Š~ à!ææ	Ö!^æ^Áæ q •d~ &c^á/q á^æq^áÁ æq ÊÁ^Á&ç }

Ö| { T æq c} æ &Á^Á&ç } Á È





# MAINTENANCE

## TROUBLESHOOTING

ÙŸT ÚVUT Ù

Ôœ¸ÙÒ

ÜÒT ÖÖÿ

MAINTENANCE

### Vibration

FËŠ[ [ •^ÁÓ[ |œ  
GËÖ~ œ!Áœ •^ { àl~  
ÀÁV, àaœœ &á

FËÖÖ @& Áœ/Á[ |œ Áœ áÁœ @ } Áœ  
ÀÁÁÁ^&[ { { ^} á^ÁÁœ | ~^Á } ^&•É  
GœËÖ @& Áœ |Áœ œ œ^Á |œÁ• Ëöã &  
ÀÁÁÁ |Áœ œ!Á @œËÜ^ |œÁÁÁ^ ^á^áÉ  
GœËÖ @& Áœ |Á á^ËÁ ] ^ËÁœÉ  
ÀÁÁÁ } œœ \* |^áÁ Á@Áœ œ!Áœ •^ { àl~

### Mower will not lift

FËÄ~ áËÖ~ äÄŠ[ ,  
GËŠ~ áœ •Áœ Áœ ^ ÜUW  
HËœœ |œ Á^ |œ Áœ  
Í Ëœœ |œ & |œ á^ |

FËÖÖ @& Áœ áÁÁ~ Á^ áÁÖ~ ä  
GËÁÁ œ^ } Á |Á^ |œÁÁÁœ \* •Áœ áÁœ •••  
HËÖÖ @& Á |Á^ •• |Áœ Áœ ^Ëöã ÁÁ  
ÀÁÁÁ |Á^ •• |Áœ ÁÓ[ ] d[ |Áœœ^ Á @~ |áÁ^  
ÀÁÁÁ Áœ œ ÖÉ œÁÜÈÈÈ  
Í ËÖÖ ] ^&dÁ^ |œÁ |Á^ |œÁ & |œ á^ |

### Mower will not start or run

FËÖ[ , } Á••  
GËÖœ/Áœœ^ •Áœ |œ •^ á  
HËŠ[ , Á Á^ ç^ |  
Í Ëöã ^Á^ œ  
Í ËÖ^ & d[ ] œ  
ÀÁÁ [ | } [ äÄœœ |œ

FËÖÖ @& Á• •^Áœ ç^ ^ } Á [ , ^!Á , œ&@Á  
ÀÁÁÁœ áÁœ } äœ } Ë^ |œÁ  
GËÄÄT œ^ Á^ |Áœœœ^ •Áœ^ Á^ |œ  
HËÖÖ @& Á^ áËöã | Áœ áÁÁ |  
Í ËÖÖ @& Áœ ÁÁœœ \* •Áœ áÁœ ^•É  
ÀÁÁÁ^ Ëö @ } Á |Á^ |œÁ  
Í äöÄ œ@~ œ@Áœœœ |Á } } ä \* Ëö } } Á  
ÀÁÁÁ@Á [ , ^!Á , œ&@Á Á } ËÖÄ[ ,  
ÀÁÁÁœ áá^ Áœ Á @~ |áÁ^ Áœ œáÁœ@Á  
ÀÁÁÁ [ | } [ äÁÁ^ } \* œ ä \* Á@Á^ | } [ ä  
ÀÁÁÁ ] [ | Ëöã ÁÁ Á [ œ@ œáË^ œ^  
ÀÁÁÁ , œ&@Á Á } Á [ • •ä } Áœ áÁ œ@Á  
ÀÁÁÁ &^ , ááœ^!Á |Á cœ!Á œ^!Á àb&É  
ÀÁÁÁ ~ &@œÁ { œ!Á^ œ } Áœ Á^ } áÁ Áœ Á  
ÀÁÁÁ [ | } [ äËÖœ@Á ^œ!ÁÁ àb&@Á | c  
ÀÁÁÁ œœœœ^ áÁÁ Áœ Á^ Ë&@& Áœ Á••  
ÀÁÁÁœ áÁ ää \* Áœ |Áœ Á^ |œ ää~ äËÖœ@Á  
ÀÁÁÁ àb&@Á Áœ œœœœ^ áÁ^ | Áœ Á^ Á  
ÀÁÁÁ@ œáË^ |œÁ Áœ Á^ | } [ äÉ  
Í äËÖÜ^ [ ç^ Áœ@Á^ |Áœ |œ Áœ |áä \* Áœ Á  
ÀÁÁÁ { œ!Áœ | & Áœ Áœ Á œœ Áœ | & Ëöäc  
ÀÁÁÁ ÁÁ^ [ ç^ Á { œ!Áœ | & Áœ Á^ \*  
ÀÁÁÁœ~ |Á [ œ!Áœ œ^ ÁÜÈä \* Ëœœ!É  
ÀÁÁÁÁ^ |œ Áœ Áœ ÁÁÄá •œÈÈ  
Í &ËÖÜ^ [ ç^ Áœ^ Á^ ^ } } Á äÁ Á^ Áœ^ Á  
ÀÁÁÁœ œœ Áœ | & ËÜ^ [ ç^ Á ] ä \* Ëöã áÁ^ Á  
ÀÁÁÁœ ^á^ Á [ •^ Áœ^ Á^ |á Áœ Á^ | | Á [ {  
à | & ËÖÖ @& Áœ | & Áœ áÁ^ | | |  
ÀÁÁÁœ |Áœ } œœ ä œœ •Áœ áÁ & œ&@•É  
ÀÁÁÁÁ^ |œ Áœ œœ Á |Á^ |œÁ ÁÁ & œ&@áÉ

Ö [ { T œœ œ } œ & ÁÜ^ & œ } Á È

# MAINTENANCE

## TROUBLESHOOTING (CONTINUED)

ÙYÏ ÚVUT Ù

ÔËÀÙÒ

ÜÒÏ ÖÖÿ

**Motor runs but  
will not cut**

FÈÖ^|σ  
GÈÀ^}·ç}^!

FÈÖÖ·]^&σ^|^σ} áÁ~||^·ÈÜ^|æ&  
ÄÖÖÖ^|^σ} áÁ^|æ& Á^ááÈ  
GÈÖÖb·σ^}·ç}^!Á^ÖæÁ æ @!  
ÄÖÖÖ æ @!ÁÁ·@\_æÖ|ÁÁ~á^È

**Mower turns slowly  
or not at all**

FÈÖ| }æ ç ç σ Á  
ÄÖÖ^·dæç\*Á|[[  
ÄÖÖ [ç^ ^}ç Á  
ÄÖÖæç^Á|á È  
  
GÈÜ~ &ç }Á^·  
ÄÖÖ á·d~ &c^áÁ  
HÈS|, Á çÁç^!

FÈÖÜ^ { [ç^Áæ\*^Á~ç} Á áÁ^Á^Áæ\*^  
ÄÖÖÖæç^Á|| & ÈÜ^ { [ç^Á}|ç\*Èá áÁ·  
ÄÖÖÖ^á^Á^ [·^Áç^Á^|ç Á^|Á|[[  
ÄÖÖÖ { Á|| & ÈÖ @ & Á|| & Á^ áÁ|[[  
ÄÖÖÖ|Á| }æ ç æ·ç} áÁ &æ&@·È  
ÄÖÖÖ|^ç Á æ σ Á^!Á^|æ&ÁÁ&æ&@áÈ  
GÈÖÖ@ & Á|Á ç|^·Á^!Á^á·d~ &ç }Á  
ÄÖÖÖ~ &ç }Á@·^È  
HÈÖÖ@ & Á^ áÁç^ \Á^ç^|Á^ áÁ||È

**Pump will not work**

FÈÖç&··ç^Á ^æ  
ÄÖÖ }Á ç!} çÁ æσ

FÈÖÖã æ·^ { à|^Áç} áÁ^|æÈ

**Motor will not work**

FÈÖç&··ç^Á ^æ  
ÄÖÖ }Á ç!} çÁ æσ

FÈÖÖã æ·^ { à|^Áç} áÁ^|æÈ

ÞUVÒKÁ|, Á ^ç!Á Áçæá|È& & Á|^·~!^ç} áÁ|, Áç| { ^Á|Áç|Á~·|^ç^áÁ@á|æ|Á|:|à|^·È  
G^@Á| |ç} Á|Á|^!Á|:|à|^ { Áç} [ ç^Á|^ } áÁ Áç^Á^&ç } È&ç|Á@Á^&@ æçÁ|^ç&Á^|^·^} æç^Áç^@  
} { à!Á @, } Á } Á@Á| } ç [ç^!Á^Áç^Á ç} æÈ

MAINTENANCE

Ó[[{

T æ ç!} ç} &^Á^&ç } Á È

# MAINTENANCE

MAINTENANCE

### Torque for Standard Fasteners

Nominal Dia. (in.)	threads per inch	Grade 2			Grade 5			Grade 8			Grade 9		
		Tightening Torque			Tightening Torque			Tightening Torque			Tightening Torque		
		Lubed K = 0.15	Dry Plated K = 0.17	Dry plain K = 0.20	Lubed K = 0.15	Dry Plated K = 0.17	Dry plain K = 0.20	Lubed K = 0.15	Dry Plated K = 0.17	Dry plain K = 0.20	Lubed K = 0.15	Dry Plated K = 0.17	Dry plain K = 0.20
<b>Unified Coarse Thread Series</b>													
1/4	20	49 in-lbs	59 in-lbs	66 in-lbs	76 in-lbs	86 in-lbs	101 in-lbs	107 in-lbs	122 in-lbs	143 in-lbs	126 in-lbs	143 in-lbs	168 in-lbs
5/16	18	101	122	135	157	178	209	221	251	295	259	294	346
3/8	16	15 ft-lbs	18 ft-lbs	20 ft-lbs	23 ft-lbs	26 ft-lbs	31 ft-lbs	33 ft-lbs	37 ft-lbs	44 ft-lbs	38 ft-lbs	43 ft-lbs	51 ft-lbs
7/16	14	24	29	32	37	42	49	52	59	70	61	70	82
1/2	13	37	44	49	57	64	75	80	90	106	94	106	125
9/16	12	53	63	70	82	92	109	115	130	154	135	153	180
5/8	11	73	87	97	113	128	150	159	180	212	186	211	248
3/4	10	129	155	172	200	227	267	282	320	376	331	375	441
7/8	9	125	150	167	322	365	429	455	515	606	533	604	710
1	8	187	225	250	483	547	644	681	772	909	799	905	1065
1 1/8	7	266	319	354	596	675	794	836	955	1132	995	1132	1341
1 1/4	7	375	450	500	840	952	1121	1171	1363	1545	1363	1545	1810
1 1/2	6	652	783	869	1462	1657	1950	2031	2371	2688	2371	2779	3306
<b>Fine Thread Series</b>													
1/4	28	56 in-lbs	68 in-lbs	75 in-lbs	87 in-lbs	99 in-lbs	116 in-lbs	123 in-lbs	139 in-lbs	164 in-lbs	144 in-lbs	163 in-lbs	192 in-lbs
5/16	24	112	135	150	174	197	231	245	278	327	287	325	383
3/8	24	17 ft-lbs	20 ft-lbs	23 ft-lbs	26 ft-lbs	30 ft-lbs	35 ft-lbs	37 ft-lbs	42 ft-lbs	49 ft-lbs	43 ft-lbs	49 ft-lbs	58 ft-lbs
7/16	20	27	32	36	41	47	55	58	66	78	68	78	91
1/2	20	41	49	55	64	72	85	90	102	120	105	120	141
9/16	18	59	71	78	91	103	121	128	146	171	151	171	201
5/8	18	82	99	110	127	144	170	180	204	240	211	239	281
3/4	16	144	173	192	223	253	297	315	357	420	369	418	492
7/8	14	138	165	184	355	403	474	502	568	669	588	666	784
1	14	210	252	280	542	614	722	765	867	1020	896	1016	1195
1 1/8	12	298	357	397	668	757	890	1083	1227	1444	1269	1439	1693
1 1/4	12	415	498	553	930	1055	1241	1509	1710	2012	1768	2004	2358
1 1/2	12	734	880	978	1645	1865	2194	2668	3024	3557	3127	3544	4169

Torque values for 1/4 and 5/16-in series are in inch-pounds. All other torque values are in foot-pounds. K = 0.15 for "lubricated" conditions  
 Torque values calculated from formula T=KDF, where K = 0.17 for zinc plated and dry conditions F = Clamp Load  
 K = 0.20 for plain and dry conditions

### Torque-Tension Relationship for Metric Fasteners

Nominal Dia. (mm)	Pitch	Class 4.6			Class 8.8			Class 10.9			Class 12.9	
		Tightening Torque			Tightening Torque			Tightening Torque			Tightening Torque	
		Lubed K = 0.15	Dry Plated K = 0.17	Dry plain K = 0.20	Lubed K = 0.15	Dry Plated K = 0.17	Dry plain K = 0.20	Lubed K = 0.15	Dry Plated K = 0.17	Dry plain K = 0.20	Lubed K = 0.15	Dry plain K = 0.20
3	0.5	0.28	0.32	0.38	0.73	0.82	0.97	1.0	1.2	1.4	1.2	1.6
3.5	0.6	0.44	0.50	0.59	1.1	1.3	1.5	1.6	1.9	2.2	1.9	2.5
4	0.7	0.66	0.74	0.87	1.7	1.9	2.3	2.4	2.7	3.2	2.8	3.8
5	0.8	1.3	1.5	1.8	3.4	3.9	4.5	4.9	5.5	6.5	5.7	7.6
6	1	2.3	2.6	3.0	5.8	6.6	7.7	8.3	9.4	11	9.7	13
6	1.25	2.1	2.3	2.7	5.3	6.0	7.0	7.6	8.6	10	8.8	12
7	1	3.8	4.3	5.0	9.7	11	13	14	16	19	16	22
8	1	5.9	6.6	7.8	15	17	20	22	24	29	25	34
8	1.25	5.5	6.2	7.3	14	16	19	20	23	27	24	31
10	1.25	11	13	15	29	33	39	42	48	56	49	66
10	1.5	11	12	14	28	32	37	40	45	53	47	62
12	1.25	21	23	28	53	60	71	76	86	101	89	119
12	1.5	20	22	26	51	58	68	73	82	97	85	113
12	1.75	19	21	25	49	55	65	70	79	93	81	108
14	1.25	26	29	34	66	75	89	95	108	127	111	148
14	1.5	28	32	37	72	82	96	103	117	138	121	161
14	2	30	34	40	78	88	104	111	126	148	130	173
16	1.5	50	57	67	129	146	171	184	208	245	215	287
16	2	47	53	62	121	137	161	173	196	230	202	269
18	1.5	73	82	97	187	212	249	268	303	357	313	417
18	2.5	65	73	86	167	189	222	239	270	318	279	372
20	2.5	91	104	122	236	267	314	337	382	449	394	525

Clamp load calculated as 75% of the proof load for specified bolts. K = 0.15 for "lubricated" conditions D = Nominal Diameter  
 All torque values are listed in foot-pounds K = 0.17 for zinc plated, dry conditions F = Clamp Load  
 Torque values calculated from formula T=KDF, where K = 0.20 for plain and dry conditions

0111

T 23 0' 23 & 1/2 8 23 } 1 2

# MAINTENANCE

## LUBRICATION RECOMMENDATIONS

**MAINTENANCE**

Description	Application	General Specification	Recommended Mobil Lubricant
Viædq  P^ â!æ  æ•Á	Ü^•^!ç[ ä	RÖËËÖ T ØÄ FFHÍ Ê FFI F ØPT GÓFHI ÖÇØPGEFD	T [ àã~ æÁ G
T [ , ^!P^ â!æ  æ• Ö [  âÁ^ { } ^!æ  ^• ÜæðM	Ü^•^!ç[ ä	ØUÁÍ ÁÇ æY ^æË , Á^ { }	T [ àãÖVÒFI T
P [ { æÁ^ { } ^!æ  ^• F »ÁÜæðM	Ü^•^!ç[ ä	RÖËËÖ T ØÄ FFHÍ Ê FFI F ØPÁT GÓFHI ÖÇØPGEFD	T [ àã~ æÁ G Á
P [ { æÁ^ { } ^!æ  ^•Á FÍ »ÁÜæðM	Ü^•^!ç[ ä	ØUÁÍ ÁÇ æY ^æ	T [ àãÖVÒÁG
P ä @Á ] ^!æ * Á^ { } É Öä [ ç^ÁÉ»Ø	Ü^•^!ç[ ä	ØUÁÍ ÁÇ æY ^æ	T [ àãÖVÒFI T
ØæÁÜæÖ^æà [ ç Ü^•^!ç[ ä	Ü^•^!ç[ ä	ÜÖÜÁ^ } @æÖçd^ { ^ Ü!^•~  ^ÁÖ^æS^ à^	T [ àãÁUPÖÁÍ Y ÈÉ T [ àãÁÜ^ } @æÖ^æ
Ö^ æ!ÁÜ @æBÁÖ [ ^ } á Ü [  ^!ÁÜ @æD Ö^ }	Ö!^æ^ Ö^ }	Šæ { Ö [ { }  ^ç Öçd^ { ^Á!^•~  ^ P SÖÖÜÁGE	T [ àã~  ^æ^ÁÖT ÈÜ
Ö!æÁÜ @æÖ [ ^ }  ^! Ö!æ áÁÜ [ æ^ D	Ö!^æ^ Ö^ }	Šæ { Ö [ { }  ^ç Öçd^ { ^Á!^•~  ^ P SÖÖÜÁGE	T [ àã~  ^æ^ÁÖT ÈÜ
Ö!æÁÜ @æÁ [ ^ É WÈ ä çBÁÜc àÁÜ@ec	Ö!^æ^ Ö^ }	Šæ { Ö [ { }  ^ç Öçd^ { ^Á!^•~  ^ P SÖÖÜÁGE	T [ àã~  ^æ^ÁÖT ÈÜ
Ö [ { ÁÜ æ   Ö [ { ÁÖ   ä á!ÁÜæ ç Ö [ ç^ ÁBÁÜæÖ [ { D	Ö!^æ^Á Ö^ }	Šæ { ÁÖ [ { }  ^ç Öçd^ { ^Á!^•~  ^ P SÖÖÜÁGEÁ	T [ àã~  ^æ^ÁÖT ÈÜ
Ö^ & ÁÖ [ { ÁÜæ çB Ö^ & ÁÜç ] ÁÖæ • ç ^ } c Ü [ ç^ ÁBÁÜæD	Ö!^æ^ Ö^ }	Šæ { ÁÖ [ { }  ^ç Öçd^ { ^Á!^•~  ^ P SÖÖÜÁGEÁ	T [ àã~  ^æ^ÁÖT ÈÜ
Ö^ & ÁÜ ä á!Ö [ ç^ D	Ö!^æ^ Ö^ }	Vä ^!ÁÜ ä á!ÁÜ^ à!æç c ] æç { à!ÁÜ     ÉÉÉÉ	T [ àãÖUPÖÁGGE

Ö [ { T æ ç } æ & ÁÜ^æç } Á È





# MAINTENANCE

## DETAILED MAINTENANCE

### REPLACING HIGH PRESSURE HYDRAULIC FILTER ELEMENT:

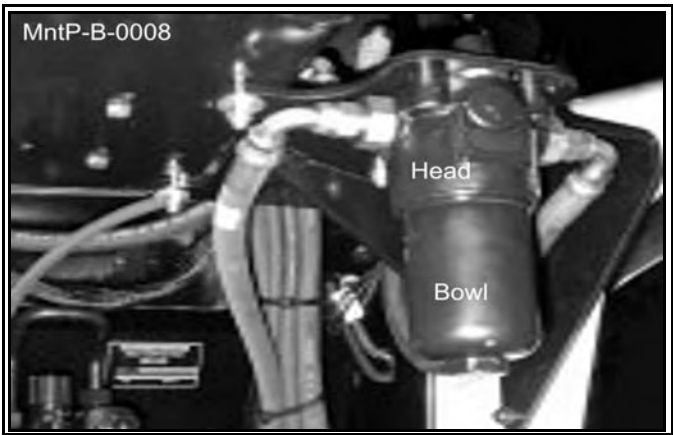

MntP-B-0008

MAINTENANCE

0E~!^Á••e\ Á@e Áá^}Á•@oá[ , }Áæ áÁá^É  
 ]!^••!á^áÉŠ &æ ÁPá @Ú!^••!^ÁQç!ÁQ~•á \*É  
 Ö[ }-á{ Ác@eÁc@Á^!^ } oÁc@eÁæ à[ ~oÁ Áá^  
 á •æ^!áÁ{ æ&@•Ác@Á^!^ } oÁ] ÉÁ[ }Ác@Á-á!  
 { [á^!Ác@e ÉÖcæ ]!^ÁXHEE FEEÉ ÁÇ [!áÁá^ÁFEEÉ  
 PÖE JÁ{ [á^!DÁŠ &æ Ác@Áá[ e{ Á[ Ác@ÁPá @  
 Ú!^••!^ÁÖ[ , ]Éæ} áÁ~•^Ác@Áá[ ]! ]æ^Á•} æ}^!  
 , ^} &Ö! :Éæ&@oá áÁ! } á \*Á ÁÁÁ~ } e!&[ & , á^  
 ! [ææ] ÉÖ[ [!á \*Áæ@Áá[ e{ Á-Ác@Áá[ , ]DÁ^ [ Ç^  
 c@Áá[ , ]Á^ [ Ác@Ác@æÉV@Áá•oÁ~ }!^Á[ ææ] •  
 , á!Á^! Áá @æ Ác@Á Éá \* Áæ•^•Ác@Á^áá \* Áæ É  
 U) &Ác@Á Éá \* Ác@e Áá^æ^áÁc@Á^áá \* Áæ Ác@  
 á[ , ]Á @~!áÁ] á Á^!^!ÉVæ á \* Áæ^Á[ Ö! Áá[ ] Ác@Áá[ , ]Éá á Ö!^ [ çá \* Ác@Áá[ , ]Á^ [ Ác@Ác@æÉV ÖÉPÖÖK  
 á[ , ]Á á!ÁÁ^! ÁÁ-Á ÁÁÚ~!^Ác@Á áÁ[ { Ác@Áá[ , ]Á ç ÁÁÁ } æ^!ÉÖÖ Á áÁ @~!áÁ^ Áá } •æ^!áÁÁ } æ á æ^á  
 á^ÁÁ Ác@Áá[ , ]Áá&ç } Ác@~ \* @c@Á^!^ } oÁ Á^ •æ^!É ÖÖ!^á Ác@Áá •æ^!Á-Ác@Áá[ , ]ÁÁáááÁ Á!^••} É  
 Ú^ [ Ç^Ác@Á^!áÁ^!^ } oÁ [ Ác@Ááç!Ác@æÁÁ-Á ]!á \* Á áÖÁÁ[ ææ] Á [ ç] ÉÖÖ[ ]•^Á-Ác@Á•^áÁ^!^ } c  
 ]! ]!^!ÉÁÚ^ [ Ç^Ác@Á^ , Á^!^ } oÁ [ Ác@Ááæá á \* ÉÁV á \* Á^!Áá \*^!Éáæáá á^ á!ææ Ác@Á Éá \* Á Ác@  
 ç] Á-Ác@Á^ , Á^!^ } oÁ [ Ác@Áááá } ÁV á \* Á^!Áá \*^!Éáæáá á^ á!ææ Ác@Á Éá \* Á Ác@  
 c@Á^!^ } oÁ Á^!^ Á^æ^áÁ } Ác@Áá •ÉÖ!^á Áá áÁ •] ^&öÁc@Á Éá \* Ác@e Áæ-á^!áÁ Ác@Áá[ , ]É^ á!ææ Á áÖ  
 [ áÉV á \* ÁÁÁ ] & , á^Á! [ææ] É &^ , Ác@Áá[ , ]Ááá Á ç Ác@Ác@æÉæ •!á \* Ác@eÁc@Áá[ , ]Ác@e Á[ oÁ^ } Áá[ ••  
 c@Áæ^áÁá ç Ác@Ác@æÉÖ[ ] ç ^ÁáÖ @-} Ác@Áá[ , ]Á ç Ác@Ác@æÉæ •á \* Ác@Á ] æ}^!^!^ } &Ö! :Éæ&@oÁ  
 ! [ææ] Á-Ác@Áá[ , ]Á á!ÁÁ^! { ^Áá @^!Á } &Ác@Á Éá \* Á } æ^•^•Ác@Á^áá \* Áæ ÉU) &Ác@Áá[ , ]Ác@e Áá[ e{ ^á  
 ~ ÉVææ É-Ác@Áá[ , ]Áá ÁÉÁ! } ÉÖÖ Áæ •!^•Ác@eÁc@Á Éá \* ÁÁÁæ^áÁ ]!^!^ Á áÖÁ Ác@Á^áá \* Áæ É  
 Ö!^ } oÁ } \* Á^~ oÁ áÁÁæ •^ á! ÁÁÁ[ , ]Á [ ]!cÉUcæoÁ Á æç ÁÁá áÁ •] ^&öÁc@Ááç!Áæ^æ&@ & á \*  
 c@eÁc@Á^!Á Á[ Á áÁáá \* Á[ { Ác@Ááç!Áæ •^ á! ÉV @ Á Áá • oÁ ÁÁÁ[ ]^ÁÁ ÁÁ~!^Á Á^!æá ]É@) Á^áá^  
 Ç ÉÁQ~!^D! Á @} Á áææ^áÁ^ Á^•d&ç } Á áææ! É

### GREASING CUTTER SHAFT-FLAIL MOWERS

Š &æ^Á!^æ^Á^!•Á } Áæ&@) áÁ-Á& e!Á c@eÇ É  
 c@•^Áæ^Á[ &æ^áÁ[ } Ác@Áá^áá \* Á& Ç!ÉÁP[! ] ç  
 &[ } ááá } •Á!^~ á^Á[ ]^Á[!Áç [ Á ]~ } ]•Áá Á^áæ@  
 á^áá \* ÉÁ •á \* ÁSæ@ { ÉÖ[ ] ]!cÁÖc^!^ ÁÁ!^••!^  
 \*!^æ^Á&[ } -á{ á \* Á Á SÖÖÉUÁGEÁ ]^ááææ } •É  
 V@ ÁÁ ÁÁÁ[ ]^Á áÖÁÁ ç} áááÁ!^æ^Á^ } Ááá  
 ! :Áæ^8 hour intervals. CAUTION: Over greasing  
 may cause premature seal failure.

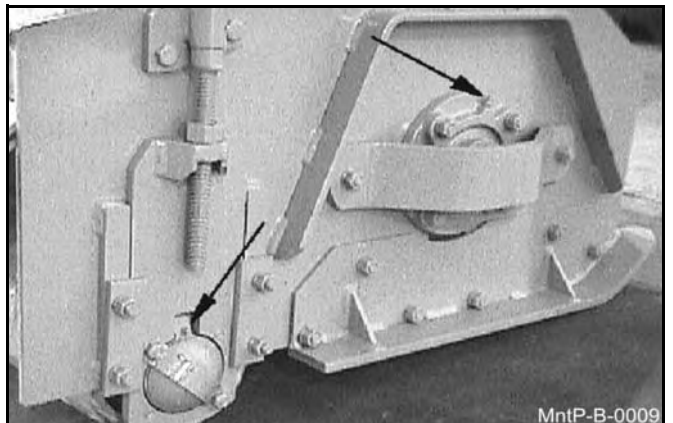

MntP-B-0009

Ö[ { T æ ç } æ & Á^ & ç } Á É G



# MAINTENANCE

## GREASING GROUND ROLLER SHAFT-FLAIL

Š[ &ae^A^i^æ^A^i\•A}ÁæA^}áA-Á[||^!Áĉ à^Áæ  
 [[, ^!A}áA-Á@æE[|{ æ/Æ}ááä}•Á~á^A}^A!  
 ç [A~{ }•AæAæ@A^æq \* EÁ•q \* Ášææ { EÖ[ ]|^ç  
 Örd^ { ^Á!^••^!Á^æ^Á/Æ}+{| q \* Aĉ Á ŠÖÖEÖU  
 HOÉÁ] ^šášææ }•EÁV@ÁšÁq Áà^Á[ ] ^Á, á@æ  
 •æ áááÁ^æ^A^~}ÁæA^ Á!Áæ8 hour intervals.  
**CAUTION: Over greasing may cause premature seal failure.**



## ADJUSTING/CHECKING BELT TENSION

V[ Áæb•OÁ|O^}•q } A!Á^|æ^A^|O A} ÁæA^æ Œ!  
 @æE^ [ ç^A^~!Á[|O Á@æ^&|^Á@A^|OÆ ç!  
 æ áA^ { [ ç^A^ ç^EÁV@Á@ç^ Á@, } Á^|, Áææ  
 à^Áæb•ç^áÁç Áæ &^æ^EÁ&^æ^Á@A^|O^}•q }  
 æ Á^ Á^áÁEÖUVÓÁŠ[ &ææ } Á- Áæb•ç^ ) O^ }  
 { æ^æ^ Á} ÁæA^æ Œ!Á@æ• E Be sure to replace  
 the belt cover BEFORE operating mower!



## TIGHTENING KNIFE BOLTS AND DISK BOLTS:

Oe!Áç^!^ Á @~!•A- A^|ææ } A!Áææ E@Áš} á  
 Ö|O Áæ áÁÖá^ Á|O Á@~|áÁ^@^} ^áÁæ A^||, •K  
 S} áA [ ~ } ç \* A^|O A^~^ A Ā EÁ q^áÁçÁ• E  
 Öá^ Á [ ~ } ç \* A^|O A^~^ A Ā EÁ q^áÁçÁ• E  
 [ q^áÁçÁ• E



Ö[ { T æ ç } æ & Á^æ } Á ĒH

# MAINTENANCE

MAINTENANCE

## GREASING POINTS ON BOOM AND PIVOT

Š[ &æ^Á^!^æ^Á^!^•^Á^} Á^&^Á^ Á^ [^•^>^ à^'É^} Á^@  
á^&^Á^} á^Á^ Á^&^&^} á^æ^ Á^[[{ É^æ^Á^ æ^É^&^} á^æ^  
à^[[{ Á^ á^ É^} á^Á^, á^Á^} á^Á^ Á^ æ^ Á^[[{ É^É^&^  
Š^æ^ { É^[[ ]^ Á^ Á^ Ó^d^>^ Á^ Ú^!^•^~!^Á^!^æ^  
&^} -!^: á^\* Á^ Á^ Š^Ó^É^Ú^Á^Á^Á^} ^&^æ^æ^} •^Á^} á^  
\*!^æ^ Á^!^ á^ Á^!^ [^d^ á^Á^[[{ Á^} á^É

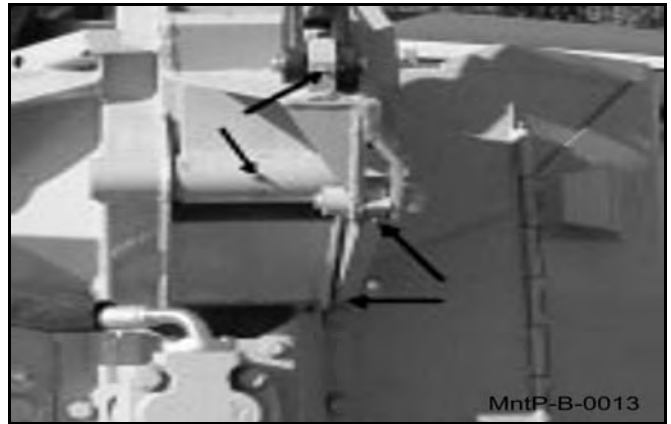

## DECK STOP ADJUSTMENT

U^} Á^[[{ Á^á^É^[[ ]^•^>^} Á^ &^ á^\* Á^ ~^ d^Á^!^} Á^æ^b^•^d^ ^} c  
à^ [^|•^>^ É^} á^Á^} Á^&^&^ Á^&^} á^ á^!^ Á^ ~^ d^ Á^ Á^||Á^c^} •^ á^ É  
Ó^á^b^•^>^ [[ ]^|•^>^ d^} á^ Á^@^æ^Á^•^>^ &^@^ Á^@^ Á^[[{ É  
æ^ á^Á^@^ } Á^ [ &^ Á^ ~^ d^ **NOTE: Bolt should not hit boom before cylinder reaches full travel.**



## GREASING SPINDLE

Š[ &æ^Á^!^æ^ Á^!^æ^ Á^!^•^ Á^} Á^ á^•^ á^ Á^ Á^&^ Á^@^ ~^ •^ á^\* É  
Q^b^&^Á^ v^!^ Á^ Ú^} á^ Á^ Á^ Š^ à^ á^æ^ d^Á^ ]^æ^Á^ } { à^!  
É^!^!^ É^É^Á^ d^ Á^ ]^ á^ Á^ Á^@^ ~^ á^\* É^Á^ Á^ á^!^ á^ á^æ^ c  
~^} á^ Á^!^ á^ á^æ^ d^, ^^} •^ Á^ [^ d^ [ Á^ ]^ Á^} á^ á^ Á^•^ á^æ^  
Š^ à^ á^æ^ Á^} á^ á^ Á^ ^^!^ Á^!^ Á^ç^!^ Á^ É^@^ ~^!^ Á^ Á^•^ É



Ó^[[{ T æ^ c^} æ^ &^ Á^!^&^} Á^ É^!

# MAINTENANCE

MAINTENANCE

## TIGHTENING SPINDLE BOLTS

Verify that the spindle bolts are tightened to the correct torque. The spindle bolts are located on the rear of the spindle housing. See Figure 1 for the location of the spindle bolts.

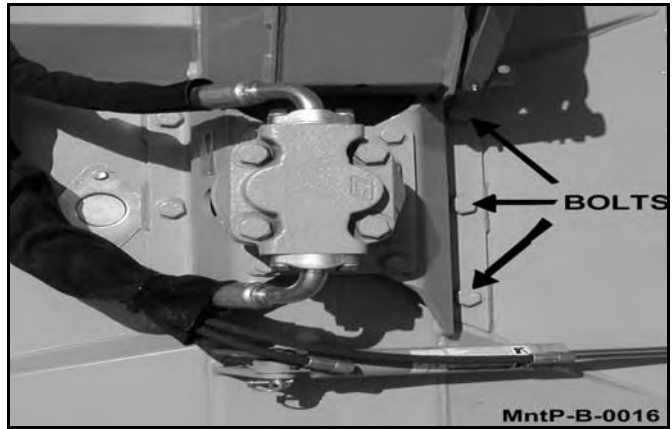

## GREASING PUMP DRIVE SHAFT COUPLER

Apply grease to the pump drive shaft coupler. The coupler is located on the rear of the pump housing. See Figure 2 for the location of the coupler. Apply grease to the coupler until the grease is visible at the top of the coupler. See Figure 3 for the correct amount of grease to apply.



# MAINTENANCE

MAINTENANCE

## DRIVE SHAFT YOKE, U-JOINT STUB SHAFT

Yoke and U-joint stub shaft assembly. The image shows the yoke and the U-joint stub shaft connected together. The yoke is a large, curved metal component, and the U-joint stub shaft is a smaller, cylindrical component. The assembly is shown from a side-on perspective.

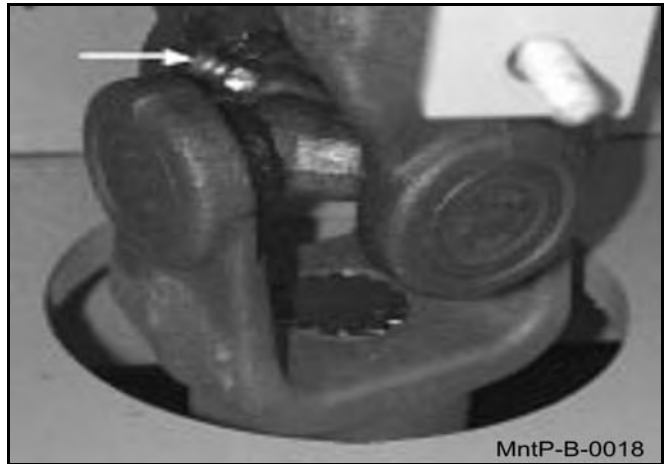

MntP-B-0018



MntP-B-0019

## GREASING THE BOOM SWIVEL

Greasing the boom swivel. The image shows the boom swivel assembly, which is a large, complex metal component. The assembly is shown from a side-on perspective. The greasing points are indicated by arrows. The greasing points are located on the boom swivel assembly.

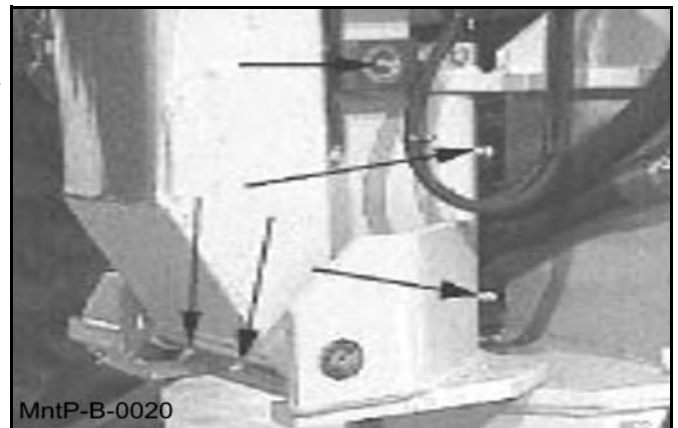

MntP-B-0020

0111

T 2 3 4 5 6 7 8 9 10 11 12 13 14 15 16 17 18 19 20 21 22 23 24 25 26 27 28 29 30 31 32 33 34 35 36 37 38 39 40 41 42 43 44 45 46 47 48 49 50 51 52 53 54 55 56 57 58 59 60 61 62 63 64 65 66 67 68 69 70 71 72 73 74 75 76 77 78 79 80 81 82 83 84 85 86 87 88 89 90 91 92 93 94 95 96 97 98 99 100

# MAINTENANCE

MAINTENANCE

## GREASING BOOM CYLINDER(S) PIVOT POINTS

Š[ &æ^Á@Á^!\Á} Á@Á^ wÁ) áÁæ \* Á -Á& |á á^!Áæ á  
 [] Á[ áÁ^} áÁæ \* ÉQb&ÁŠæ { ÉÖ[ { ] |^ÁÁÖæ^ ^  
 Ú!^••^!^Á^!^æ^Á& } -á{ á \* Áđ Á ŠÖÖÉ ÖUÁHGE  
 • ] ^&ááæ } • Á } á^!^æ^Á^\* á • Áđ Á | | d^ á^Á! {  
 ^ } á • ÉÁV@ Á | | &^ á^!^Á^ Á^ Á^ • ^áÁ } Á@Á^ æ  
 à[ [ { Á& |á á^!ÉÁ • ^& } áæ^ Á à[ [ { Á& |á á^!ÉÁ^&  
 ] á | dÁæ áÁ • , á^!Á& |á á^! • Ááæ Á | ÁæÁ Á @^!  
 á c^!çæ É

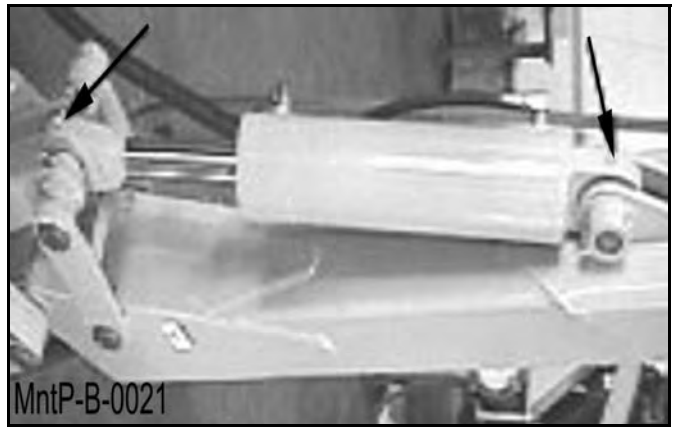

## BALL VALVES

V@ Áæ | Áçæ^ ÁæÁ@ Á@ á!æ | áÁ^ • ^!ç | áÁ æ Á ^ á  
 đ Á^ Á& | • ^ áÁ^ | á \* Á& | æ Á } æ c } æ & Á | Á^ } æ  
 ] | | &^ á^!^ • É **THE BALL VALVES MUST BE OPEN**  
**(handle parallel with valve) WHEN TRACTOR IS**  
**RE-STARTED OR PUMP IS COUPLED TO**  
**MOTOR OR P.T.O.!** Áæá^!^Áç Áá [ Á [ Á ] áÁ^ • | ç  
 & { [ ] ^ } Áæá^!^Á

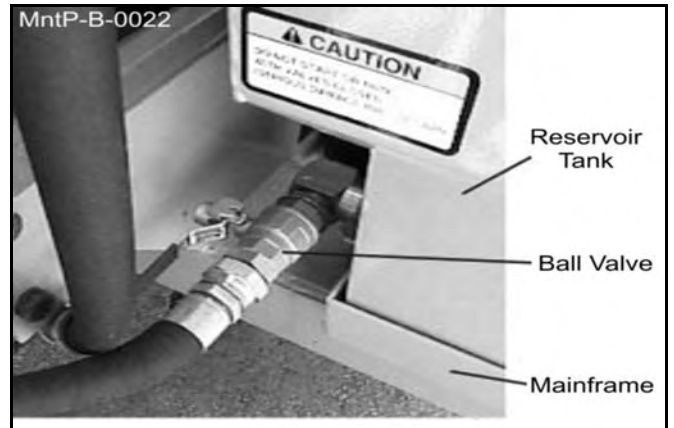

Ö [ { T æ c } æ & Á^ & ç } Á È Ì



# MAINTENANCE

**MAINTENANCE**

## ROTARY KNIFE REPLACEMENT

- FÈ ÓÁ`!Á[~Á@ce^Áæ{ ]|^Á ææ@\*Á^ÁÁ, Á }á·Á|Á^}|æ{ ^} È
- È Ü^ [ç^Á }á·Áæ á·Á·}^&@|·Á|Áæ æ^É[ Á æ&@!Áæ·Á Á@Áá \ÇÁ }|æá|Áæ [ ~ }á@Á|^·È
- HÈ Š`àÁ@ÁæÁ á·Áæ çã^á^ÉQ·æ|Á[|·Á@[~\* Á) á·Áæ á·Áá \Á [ { Á[ ã [ Á á·Á-Áá \É]æ^ÁæÉ Q·æ|Á, Á^|·Á & á·Á· Á·Áá |~^Á@{ Á Á ÉÁæ·È
- I È V@Á }á·Á@~|á, á·Á^·|Á Áæ·|á@&·Á { Á ]æ&@ } Á dá á·Á á·Á&·È

**⚠ WARNING** WHEN CUTTING HEAVY BRUSH, KNIFE BOLTS SHOULD BE INSPECTED HOURLY AND RETORQUED TO 1070 DRY OR 800 OILED FT. LBS.

## REPLACEMENT OF ROTARY DISK/BLADE BAR

**⚠ CAUTION** Failure to follow the following warnings and instructions may result in serious injury or damage to the equipment or property!

- FÈ V@Á |·Á@Áææ@Áá \ Á Á@Á }á·Á··Á^ÁæÁ ÉV@·^Á É &@ [ |·Á^Á ÁÁ |~^ÁÁ È È Á |·Á |·Á |·Á á·ÁÁ·È
- È É@ÁæÁ & á·Áæ^ } Á æ^Á} |áÁ Á@ÁæÁ ÁÁ [ ~ } á·Á |·Á ^|·Á@ Áæ·Á·æ|ÁÈ
- HÈ **Disks must be inspected daily for hairline cracks between spindle mounting bolts or around the knife mounting bolts. These cracks indicate metal fatigue caused by severe abuse. If cracks are present the disk must be replaced.**
- I È Q·^&@Áá \ Á [ ~ } á·Á |·ÁæÁ Á @} Á&@ & á·Á @·^·Á-Á } á·Á [ ~ } á·Á |·Á Áá \ { [ ~ } á·Á |·Á Á [ ~^É Á·Á· { ç^Á@Áæ·Á Áá \ Á·Á· Á@ÁæÁ & á·Áæ^ } Á } |ááæ á ç@^}^ÁÁ } |·Á |·Á |·Á |~^Áæ^ È
- í È QÁ } á·Á [ ~ } á·Á |·Á [ ·^É@Á^|·Á & á·Á·Á· } á·Á·Á |æ^Áá Áæ^Á^&æ ç } È Š`á·Áæ c@ÁæÁ á·Áæ çã^á^ÉQ·æ|Á[|·Á@[~\* Á) á·Áæ á·Áá \É]æ^ÁæÁ [ { Á[ ã [ Á á·Á-Áá \É]æ^ÁæÉ [ & á·Á· Á·Áá |~^Á@{ Á Á ÉÁæ·È













# MAINTENANCE

MAINTENANCE

## THE SPINDLE ASSEMBLY

Ú^Á@Áæ!æ Á^[[, Á!Á^ cææ}Á-Á]æá^ÁæóÉ @^Á^çæ\*É

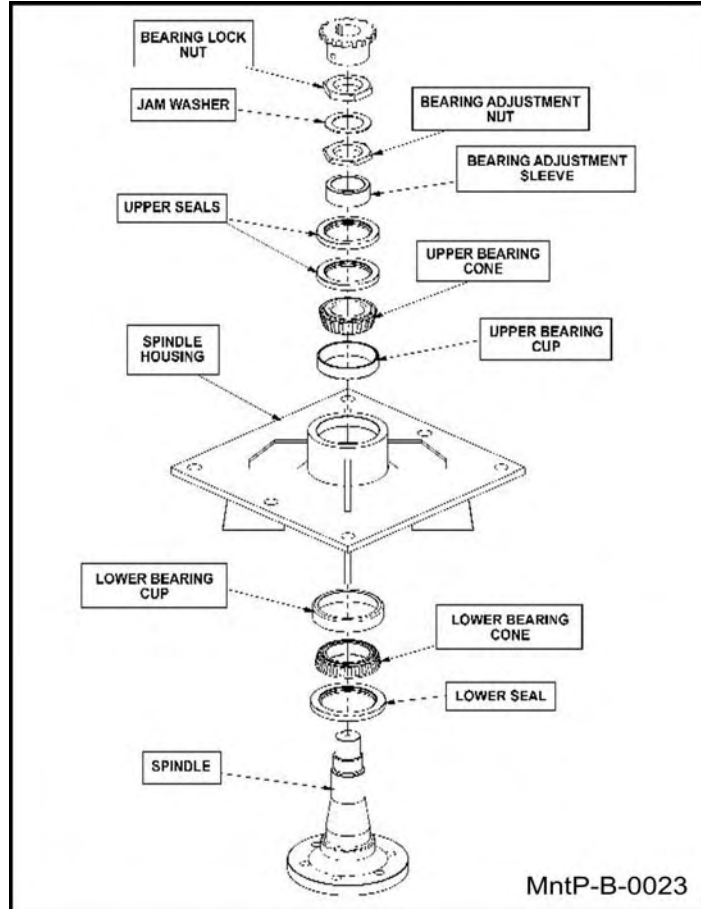

Ó[[{

Tæç}æ&Á^æ}ÁÉ

Í 4234'Cxo q'I tqw 'Ipe0









# MAINTENANCE

MAINTENANCE

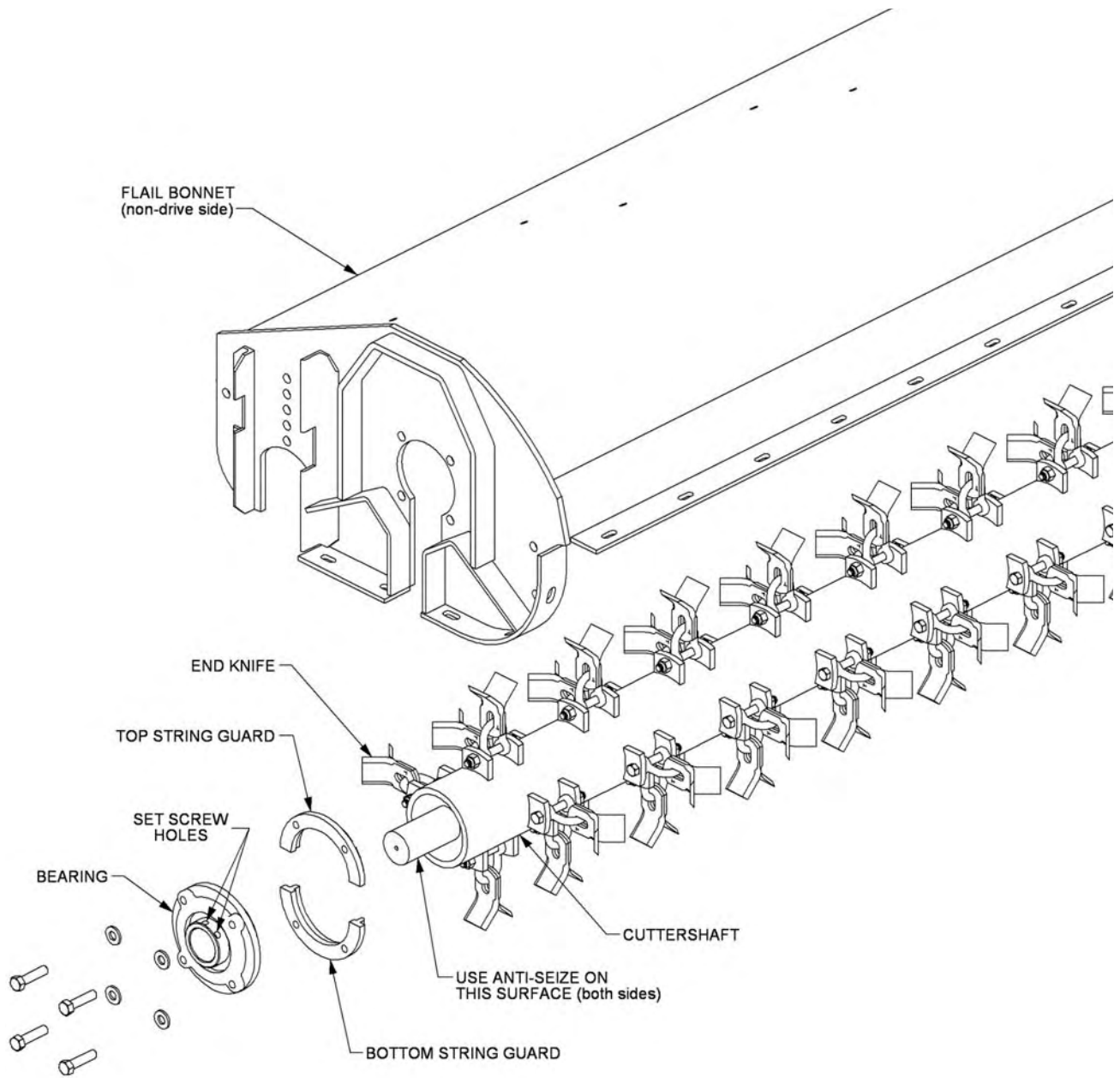

0111

Technical drawing of a flail assembly



# KUB M135GX BENGAL BRUTE BOOM

## PARTS SECTION

# PART NAME INDEX

RCTVUQTFGT&I 'I W&F G	5
VTCEVQT'O QWP V'MK	6
VTCEVQT'O QWP V'MK/'J [ FTCWN&E U	8
DQO 'O QWP V'MK	:
DQO 'O QWP V'MK/'DWNMJ GCF	32
CZNG'DTCEG'CUUGO DN	34
6"URQQN'ECDNG'EQP VTQN'O QWP V	36
ECDNG'*O CP WCN+'N&HV'XCNXG/'6"URQQN	38
7"URQQN'ECDNG'EQP VTQN'O QWP V	3:
ECDNG'*O CP WCN+'N&HV'XCNXG/'7"URQQN	42
LQ[ UV&EM'CP F 'UY &EJ 'DQZ'O QWP V	44
GNGEVTQP &E 'RTQRQTV&P CN'N&HV'XCNXG	46
DWNMJ GCF 'J QUG'CUUGO DN [ '/'TGCT'UVQY	48
DWNMJ GCF 'J QUG'CUUGO DN [ '/'U&F G'HNC K	4:
ECDNG'*O CP WCN+'N&HV'XCNXG'DTGCMF QY P '/'2872429:	52
ECDNG'*O CP WCN+'N&HV'XCNXG'DTGCMF QY P '/'2872429;	54
ECDNG'*O CP WCN+'N&HV'XCNXG'DTGCMF QY P '/'287242; 6	56
RQN[ ECTDQP CVG'UCHGV[ 'Y &F QY	58
Y J GGN'Y GK J V/'ECUV'KTQP 'TKO U	5:
Y J GGN'Y GK J V/'UVGGN'TKO U	5;
P QVGLU	62

## PARTS ORDERING GUIDE

The following instructions are offered to help eliminate needless delay and error in processing purchase orders for the equipment in this manual.

1. The Parts Section is prepared in logical sequence and grouping of parts that belong to the basic machine featured in this manual. Part Numbers and Descriptions are given to help locate the parts and quantities required.
2. The Purchase Order must indicate the **Name and Address** of the person or organization ordering the parts, **who should be charged**, and if possible, the **serial number of the machine** for which the parts are being ordered.
3. The purchase order must clearly list the **quantity of each part**, the complete and correct **part number**, and the basic **name of the part**.
4. The manufacturer reserves the right to substitute parts where applicable.
5. Some parts may be unlisted items which are special production items not normally stocked and are subject to special handling. Request a quotation for such parts before sending a purchase order.
6. The manufacturer reserves the right to change prices without prior notice.

NOTE: When ordering replacement decals, refer to the part numbers and descriptions listed in the safety section in the front of this manual.



For maximum safety and to guarantee optimum product reliability, always use genuine **Tiger** replacement parts. The use of inferior replacement parts may cause premature or catastrophic failure which could result in serious injury or death.

Direct any questions regarding parts to:

**Tiger Corporation**  
3301 N. Louise Ave.  
Sioux Falls, SD 57107  
1-800-843-6849  
1-605-336-7900

# TRACTOR MOUNT KIT

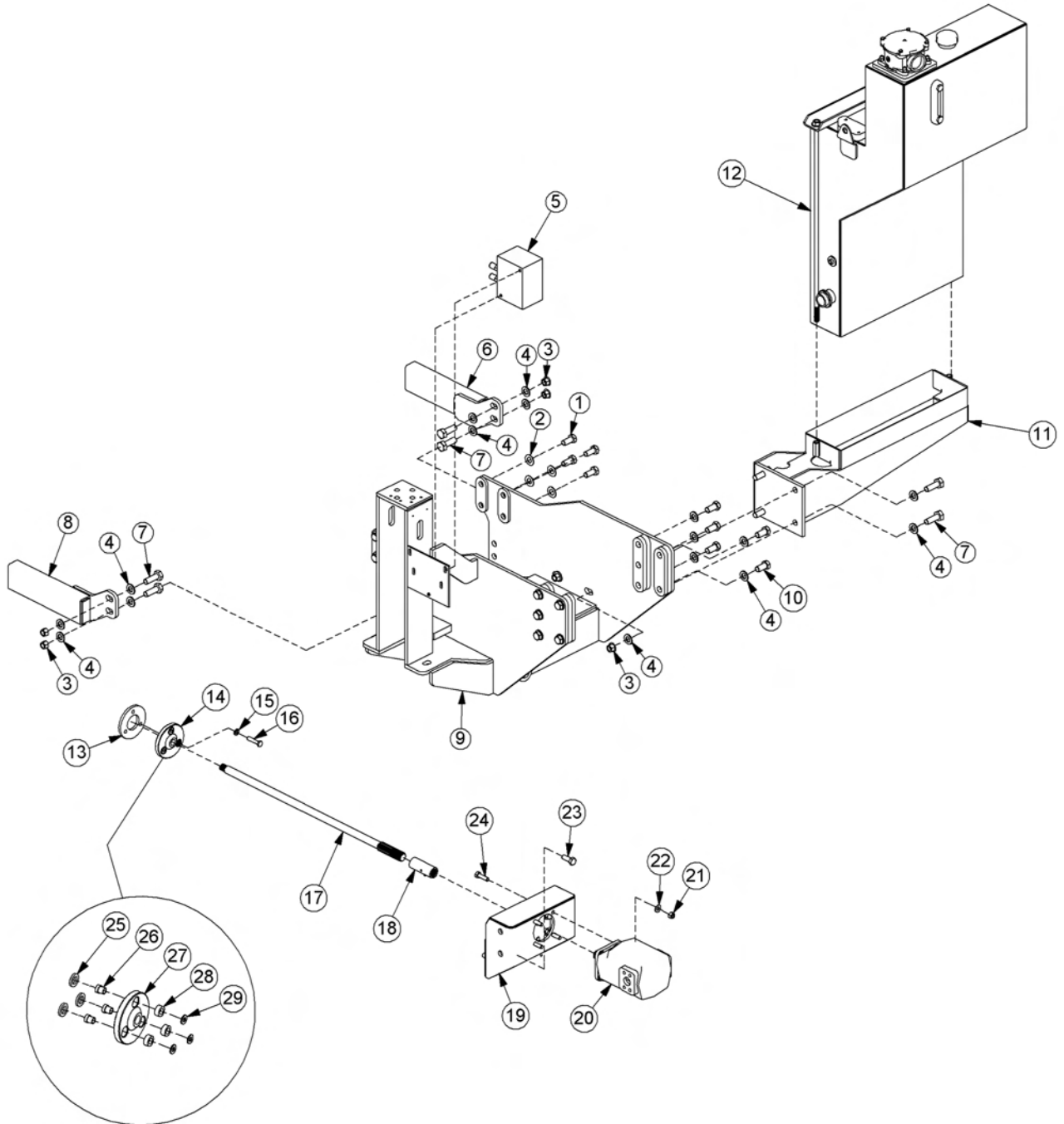

## TRACTOR MOUNT KIT

Continued...

ITEM	PART NO.	QTY.	DESCRIPTION
1	06530531	8	CAPSCREW,18MM X 40MM,1.5P
2	06533005	8	FLATWASHER,18MM
3	21825	8	HEX NUT,3/4",NC
4	33880	26	FLATWASHER,3/4",SAE
5	06510083	1	VALVE,BRAKE
6	-----	-	AXL BRC,LH *REFER TO BOOM MOUNT KIT
7	21833	8	CAPSCREW,3/4" X 2-1/4",NC
8	-----	-	AXL BRC,RH *REFER TO BOOM MOUNT KIT
9	06300106	1	MAIN FRAME
10	06530532	10	CAPSCREW,20MM X 40MM,1.5P
11	06300060	1	MOUNT,HYDRO TANK
12	06700090	1	HYDRAULIC TANK
13	06400393	1	SPACER,CRNKSHFT ADPTR
14	06700043	1	ADAPTER,CRANKSHAFT
15	27724	3	LOCKWASHER,12MM
16	24962	3	CAPSCREW,12MM X 55MM,1.25P
17	06420154	1	DRIVE SHAFT,PUMP
18	6T0375B	1	COUPLING,14 SPLINE,W/ZERK
19	06380011	1	PUMP MNT
20	23152	1	PUMP
21	21725	4	HEX NUT,1/2",NC
22	06533004	4	FLATWASHER,1/2",SAE
23	6T2521	4	CAPSCREW,16MM X 40MM,1.5P
24	21732	4	CAPSCREW,1/2" X 1-3/4",NC
25	06537004	3	WASHER,NEOPRENE,.75" X 1.25" X .19"
26	6T3202	3	GROMMET,STEEL,12MM
27	6T0450	1	CRANKSHAFT ADAPTER
28	6T3218	3	GROMMET,RUBBER
29	24937	3	FLATWASHER,7/16",SAE

# TRACTOR MOUNT KIT - HYDRAULICS

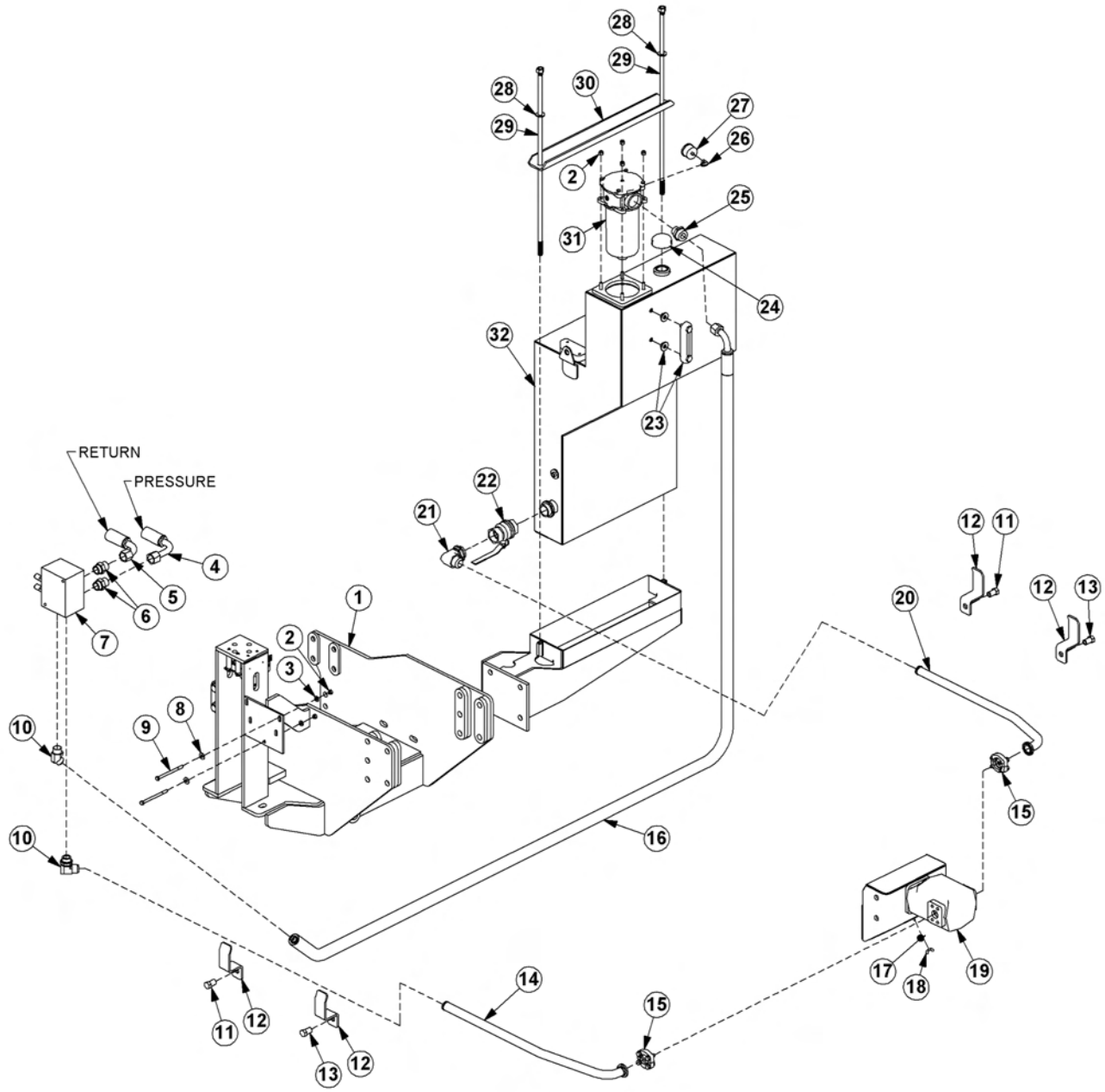



## TRACTOR MOUNT KIT - HYDRAULICS

Continued...

ITEM	PART NO.	QTY.	DESCRIPTION
1	-----	-	MAIN FRAME *REFER TO TRACTOR MOUNT KIT
2	21625	2	HEX NUT,3/8",NC
3	21988	2	LOCKWASHER,3/8"
4	06500328	1	HOSE,1" X 96" (RETURN)
5	06500329	1	HOSE,1" X 93" (PRESSURE)
6	33555	2	ADAPTER,1"MOR X 1"MJ
7	-----	-	BRAKE VALVE *REFER TO TRACTOR MOUNT KIT
8	22016	2	FLATWASHER,3/8"
9	21644	2	CAPSCREW,3/8" X 5",NC
10	33554	2	ELBOW,1"MOR X 1"MJ,45°
11	-----	-	CAPSCREW *REFER TO TRACTOR MOUNT KIT
12	32382	4	HOSE CLAMP
13	06530510	2	CAPSCREW,16MM X 25MM,1.5P
14	06500597	1	HOSE,1" X 68"
15	TF4852	2	FLANGE KIT
16	06500239	1	HOSE,1" X 124"
17	22014	1	FLATWASHER,1/4"
18	32519	1	WING NUT,1/4",NC
19	-----	1	PUMP *REFER TO TRACTOR MOUNT KIT
20	06500294	1	HOSE,1-1/2" X 74"
21	34655	1	ELBOW,1-1/2"MOR X 1-1/2"MJ
22	34309	1	BALL VALVE, 1-1/2"FOR
23	06505067	1	SIGHT GAUGE
---	06503175	1	SEAL KIT,SIGHT GAUGE,LENZ
24	06505077	1	CAP,PRESSURE
25	34064	1	ADAPTER,1-1/4"MOR X 1"MJ
26	TF4888	1	STREET ELBOW,1/8"
27	6T0649	1	FILTER GAUGE
28	33764	2	FLATWASHER,7/16",SAE
29	06380014	2	TIE BOLT,SIDE TANK
30	06410352	1	CHANNEL,MNT,TANK
31	06505044	1	FILTER,IN-TANK,CPLT
32	06700090	1	HYDRAULIC TANK ASSEMBLY
---	06380012	1	HYDRAULIC TANK WELDMENT

# BOOM MOUNT KIT

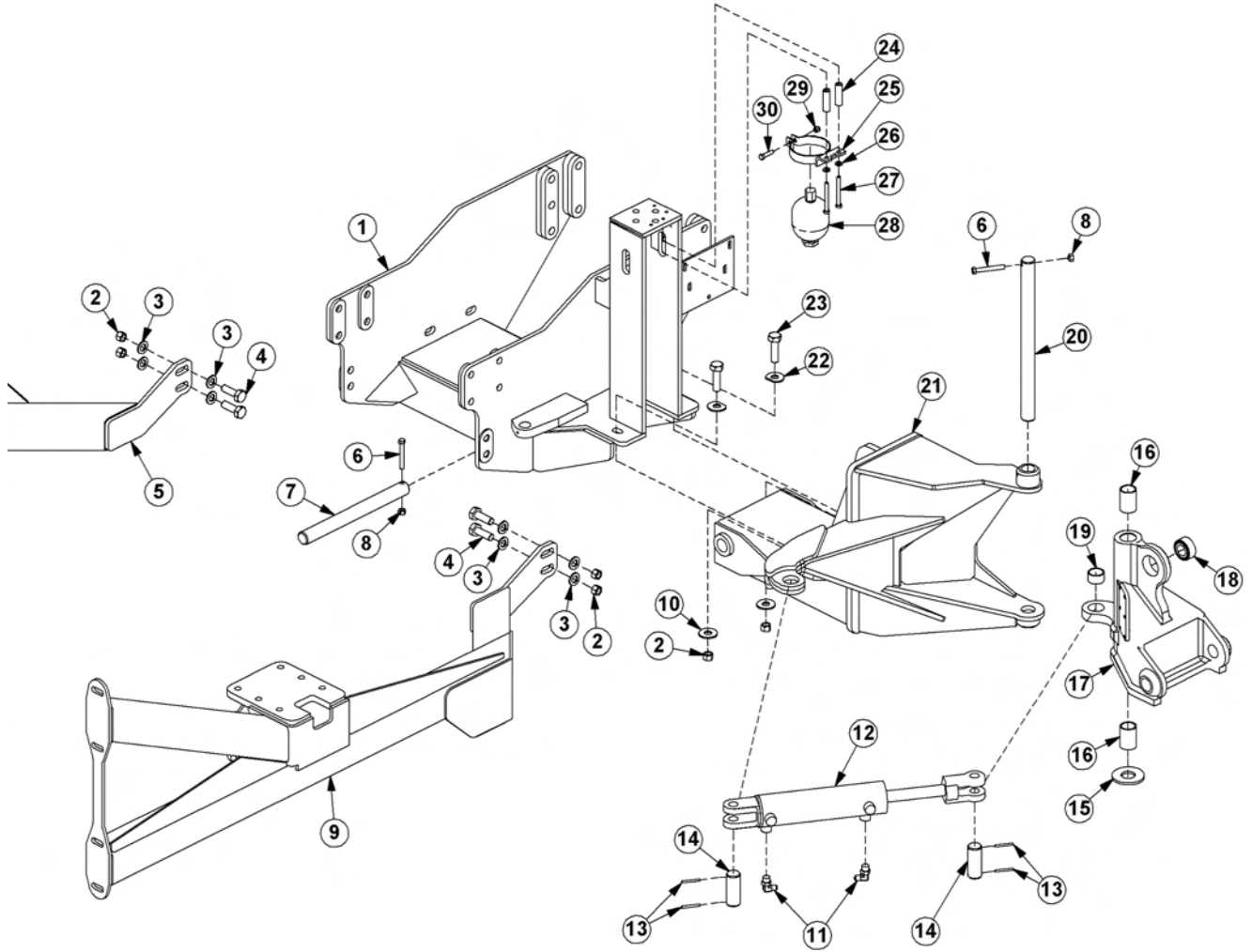

## BOOM MOUNT KIT

Continued...

ITEM	PART NO.	QTY.	DESCRIPTION
1	-----	-	MAIN FRAME *REFER TO TRACTOR MOUNT KIT
2	21825	6	HEX NUT,3/4",NC
3	33880	8	FLATWASHER,3/4",SAE
4	21833	4	CAPSCREW,3/4" X 2-1/4",NC
5	06300216	1	AXLE BRACE,LEFT HAND
6	21688	2	CAPSCREW,7/16" X 3-1/4",NC
7	6T3001	1	PIN,1-1/2"
8	21677	6	NYLOCK NUT,7/16",NC
9	06300215	1	AXLE BRACE,RIGHT HAND
10	22021	2	FLATWASHER,3/4"
11	32810	2	ELBOW,1/2"MOR,ADJ X 3/8"MJ
12	06501019	1	CYLINDER,4" X 9"
13	TB1023	4	ROLL PIN
14	06420023	2	PIN,1-1/2"
15	06520049	1	BEARING,SWING
16	06520075	2	BEARING,1-1/2"OD X 2-1/2"
17	06700017	1	SWIVEL ASSEMBLY
---	06310003	1	SWIVEL WELDMENT
18	-----	-	BEARING,SPHERICAL *NOT FOR SALE
19	06520108	1	BEARING,1-1/2"OD X 1"
20	06420013	1	PIN,1-1/2"
21	06700040	1	BRACKET,BOOM MOUNT,ASSEMBLY
---	06310005	1	BRACKET,BOOM MOUNT,WELDMENT
22	6T2607	2	WASHER,3/4",CUT
23	21835	2	CAPSCREW,3/4" X 2-3/4",NC
24	06420054	2	SPACER
25	23888	1	BRACKET,ACCUMULATOR
26	21988	2	LOCKWASHER,3/8"
27	21640	2	CAPSCREW,3/8" X 3-1/2",NC
28	24300	1	ACCUMULATOR
29	21627	1	NYLOCK NUT,3/8",NC
30	21632	1	CAPSCREW,3/8" X 1-1/2",NC

# BOOM MOUNT KIT - BULKHEAD

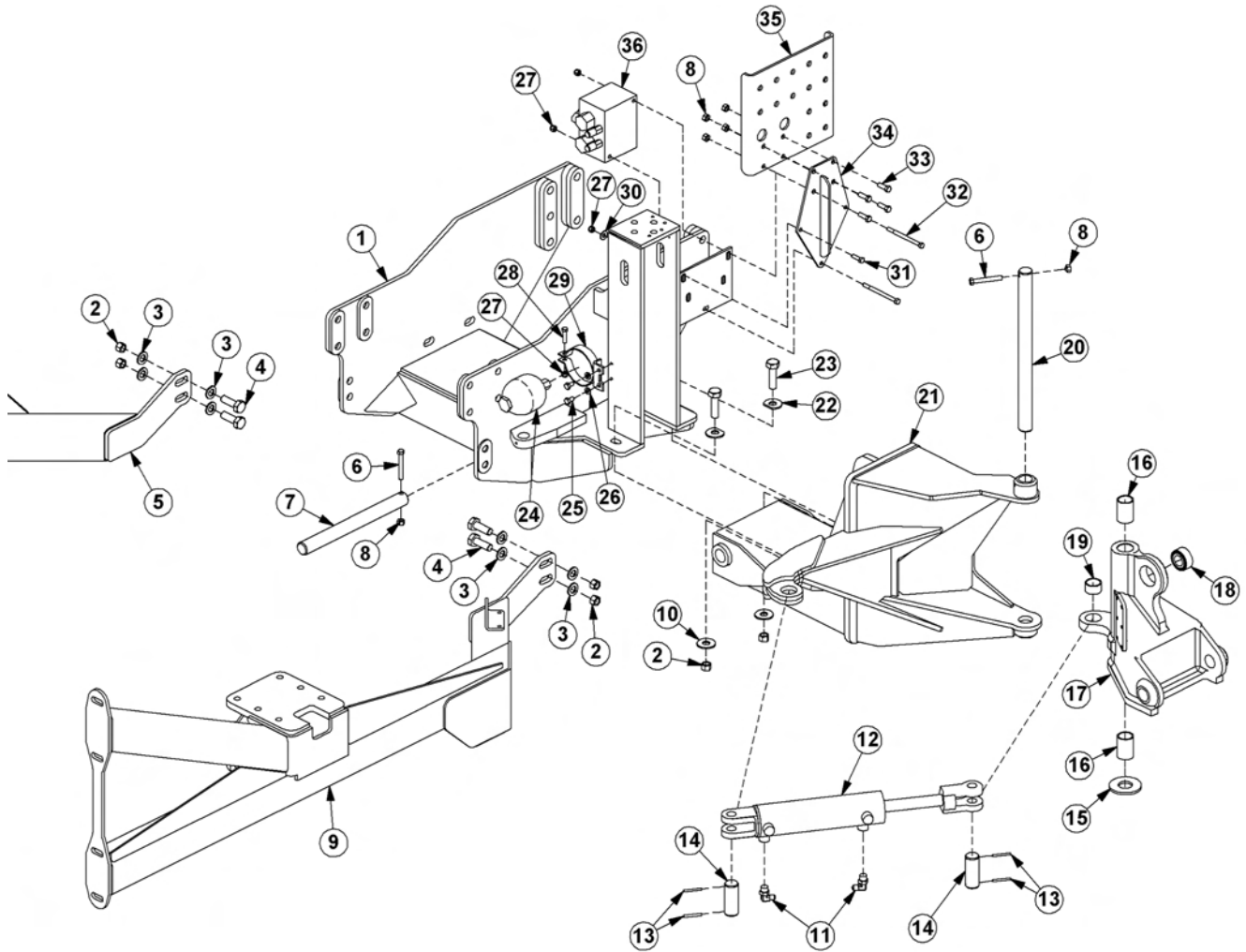

## BOOM MOUNT KIT - BULKHEAD

Continued...

ITEM	PART NO.	QTY.	DESCRIPTION
1	-----	-	MAIN FRAME *REFER TO TRACTOR MOUNT KIT
2	21825	6	HEX NUT,3/4",NC
3	33880	8	FLATWASHER,3/4",SAE
4	21833	4	CAPSCREW,3/4" X 2-1/4",NC
5	06300216	1	AXLE BRACE,LEFT HAND
6	21688	2	CAPSCREW,7/16" X 3-1/4",NC
7	6T3001	1	PIN,1-1/2"
8	21677	6	NYLOCK NUT,7/16",NC
9	06300215	1	AXLE BRACE,RIGHT HAND
10	22021	2	FLATWASHER,3/4"
11	32810	2	ELBOW,1/2"MOR,ADJ X 3/8"MJ
12	06501019	1	CYLINDER,4" X 9"
13	TB1023	4	ROLL PIN
14	06420023	2	PIN,1-1/2"
15	06520049	1	BEARING,SWING
16	06520075	2	BEARING,1-1/2"OD X 2-1/2"
17	06700017	1	SWIVEL ASSEMBLY
---	06310003	1	SWIVEL WELDMENT
18	-----	-	BEARING,SPHERICAL *NOT FOR SALE
19	06520108	1	BEARING,1-1/2"OD X 1"
20	06420013	1	PIN,1-1/2"
21	06700040	1	BRACKET,BOOM MOUNT,ASSEMBLY
---	06310005	1	BRACKET,BOOM MOUNT,WELDMENT
22	6T2607	2	WASHER,3/4",CUT
23	21835	2	CAPSCREW,3/4" X 2-3/4",NC
24	24300	1	ACCUMULATOR
25	21629	2	CAPSCREW,3/8" X 3/4",NC
26	21988	2	LOCKWASHER,3/8"
27	21627	4	NYLOCK NUT,3/8",NC
28	21632	1	CAPSCREW,3/8" X 1-1/2",NC
29	23888	1	BRACKET,ACCUMULATOR
30	22016	1	FLATWASHER,3/8"
31	21631	1	CAPSCREW,3/8" X 1-1/4",NC
32	21644	2	CAPSCREW,3/8" X 5",NC
33	21680	4	CAPSCREW,7/16" X 1-1/4",NC
34	06370199	1	MOUNT,BULKHEAD
35	06410822	1	BULKHEAD
36	-----	-	BRAKE VALVE *REFER TO TRACTOR MOUNT KIT

# AXLE BRACE ASSEMBLY

TOP VIEW OF RIGHT AXLE BRACE

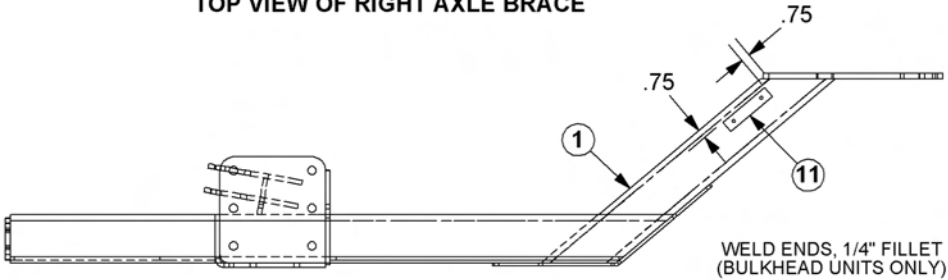

ITEMS 7 THRU 11 USED ON BULKHEAD UNITS ONLY

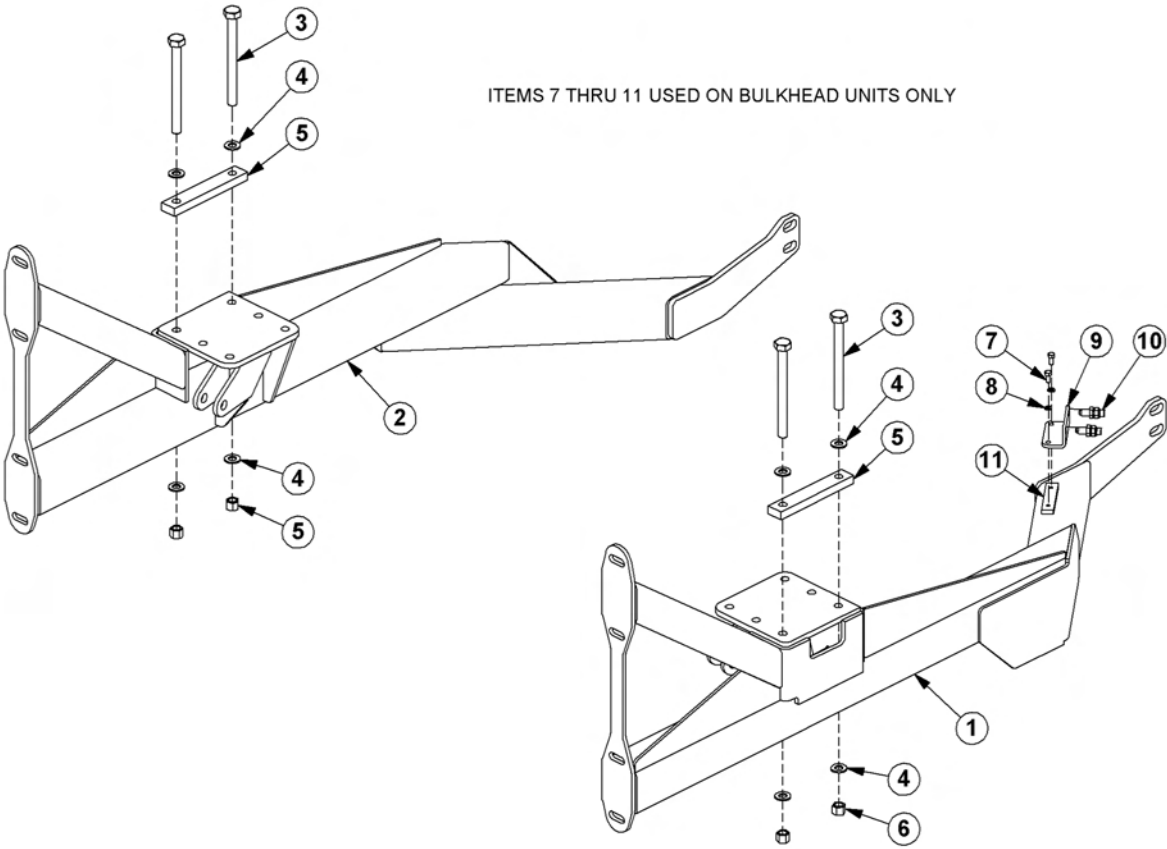

## AXLE BRACE ASSEMBLY

Continued...

ITEM	PART NO.	QTY.	DESCRIPTION
1	06300215	1	AXLE BRACE,RIGHT HAND
2	06300216	1	AXLE BRACE,LEFT HAND
3	06530214	4	CAPSCREW,5/8" X 8-1/2",NC
4	33764	8	FLATWASHER,5/8",SAE
5	06400631	2	STRAP,AXLE
6	21777	4	NYLOCK NUT,5/8",NC
7	21579	2	CAPSCREW,5/16" X 3/4",NC
8	21987	2	LOCKWASHER,5/16"
9	06410823	1	BRACKET,BULKHEAD,SMALL
10	-----	-	FITTING,BULKHEAD *REFER TO QUICK COUPLER PAGE
11	06401933	1	PLATE,MOUNT,BULKHEAD

# 4 SPOOL CABLE CONTROL MOUNT

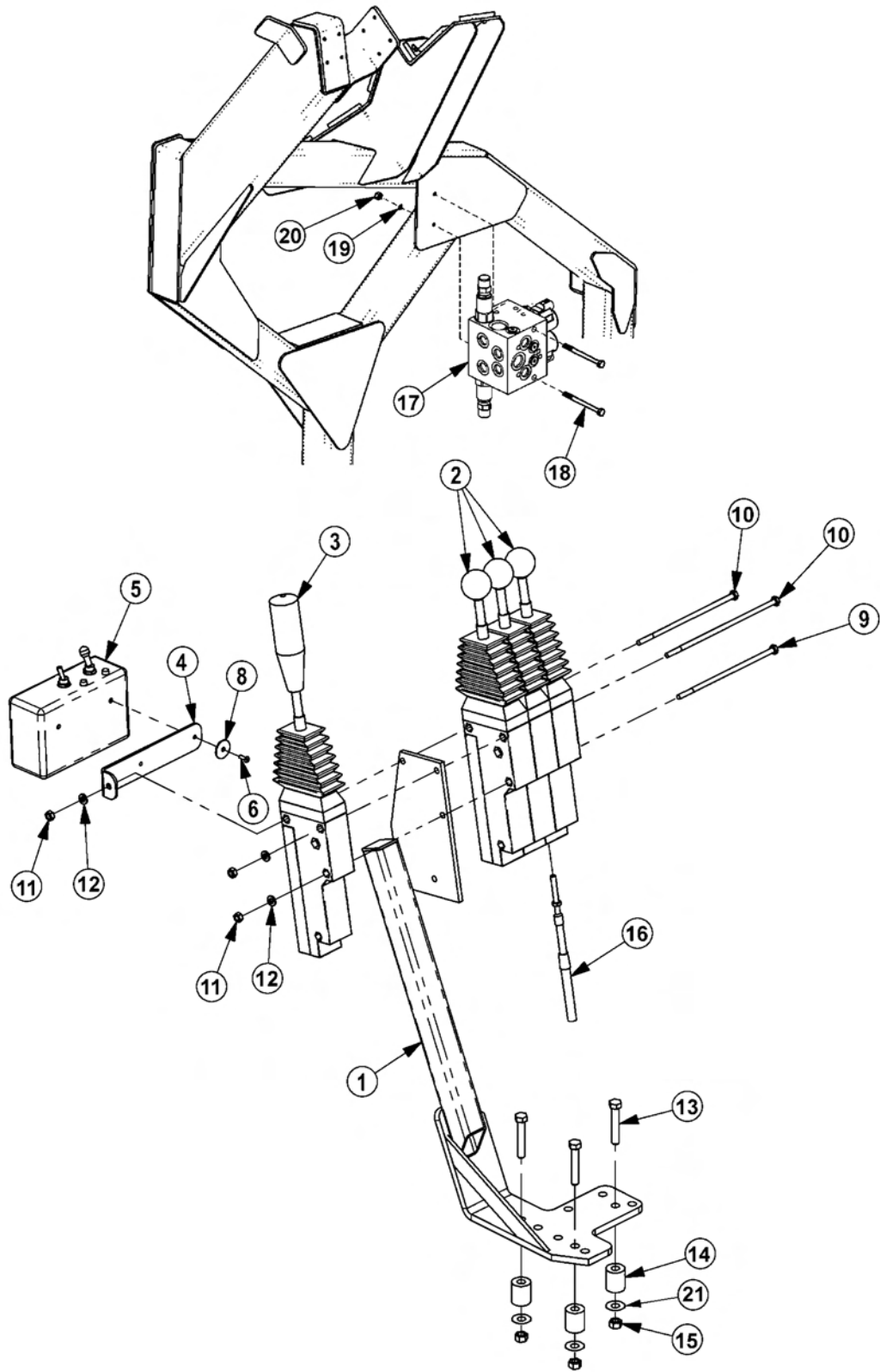



## 4 SPOOL CABLE CONTROL MOUNT

Continued...

ITEM	PART NO.	QTY.	DESCRIPTION
1	23865B	1	CBL CTRL MT BRK
2	6T1251	3	CBL CTRL BOX
3	06505023	1	CBL CTRL BOX,W/BUTTON
4	34496	1	BRKT,SWITCHBOX,UNI
5	06510049	1	SWITCHBOX ASSY,BOOM,RS
6	6T3951	2	SCREW,MACHINE,8/32 X 1/2"
8	34508	2	WASHER,FENDER,#10
9	21546	1	CAPSCREW,1/4" X 7",NC
10	21547	2	CAPSCREW,1/4" X 8",NC
11	21525	3	HEX NUT,1/4",NC
12	21986	3	LOCKWASHER,1/4"
13	21636	3	CAPSCREW,3/8" X 2-1/2",NC
14	27082B	3	SPACER
15	21627	3	NYLOCK NUT,3/8",NC
16	34623	4	CBL,CNTRL,122"
17	06502055	1	VLV,SELECTOR,RS
18	21593	2	CAPSCREW,5/16" X 4-1/2",NC
19	21987	2	LOCKWASHER,5/16"
20	21575	2	HEX NUT,5/16",NC
21	6T2615	3	WASHER,FENDER,3/8"

# CABLE (MANUAL) LIFT VALVE - 4 SPOOL

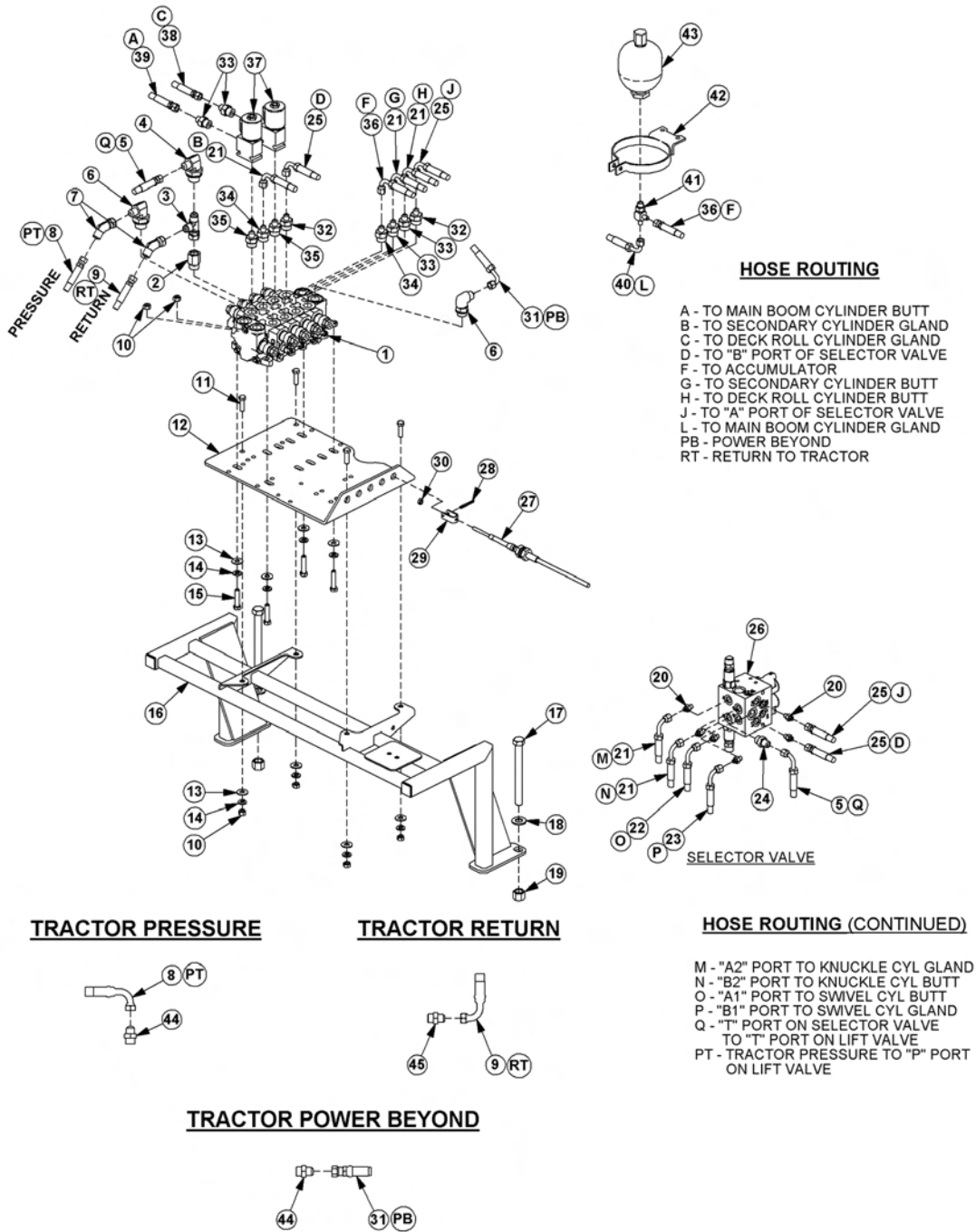

ITEM	PART NO.	QTY.	DESCRIPTION
1	06502079	1	4 SPOOL VALVE,MANUAL (FLAIL MOWERS)
---	06502094	1	4 SPOOL VALVE,MANUAL (ROTARY MOWERS)
2	32678	1	ADAPTER,5/8"MOR X 1/2"FOR
3	6T3992	1	RUN,TEE,1/2"MJ X 1/2"FX X 1/2"MJ
4	33382	1	ELBOW,1/2"MOR X 1/2"MJ
5	06500171	1	HOSE,1/2" X 36"

## CABLE (MANUAL) LIFT VALVE - 4 SPOOL

Continued...

ITEM	PART NO.	QTY.	DESCRIPTION
6	33383	2	ELBOW,5/8"MOR X 1/2"MJ
7	33483	2	ELBOW,1/2"MJ X 1/2"FXJ 45°
8	06500564	1	HOSE,1/2" X 42"
9	33649	1	HOSE,1/2" X 50"
10	21625	8	HEX NUT,3/8",NC
11	21631	4	CAPSCREW,3/8" X 1-1/4",NC
12	34622	1	PLATE,VALVE,REAR MT
13	22016	8	FLATWASHER,3/8"
14	21988	8	LOCKWASHER,3/8"
15	21632	4	CAPSCREW,3/8" X 1-1/2",NC
16	06340047	1	VALVE MNT
17	06530228	2	CAPSCREW,5/8" X 6-1/2",NC
18	33764	2	FLATWASHER,5/8",SAE
19	21777	2	NYLOCK NUT,5/8",NC
20	32901	6	ADAPTER,3/8"MOR X 3/8"MJ
21	34358	5	HOSE,1/4" X 196"
22	33364	1	HOSE,1/4" X 120"
23	33407	1	HOSE,1/4" X 110"
24	33528	1	ADAPTER,1/2"MOR X 1/2"MJ
25	33744	2	HOSE,1/4" X 34"
26	06502055	1	SELECTOR VALVE
27	34623	4	CBL,CNTRL,122"
28	6T3017	4	ROLLPIN,3/16" X 1"
29	6T4411	4	CLEVIS,3/16"
30	21500	4	HEX NUT,1/4",NF
31	06500478	1	HOSE,1/2" X 34"
32	34396	2	ADAPTOR,.06 RSTRCTR,1/2"MOR X 3/8"MJ
33	33271	4	ADAPTOR,1/2"MOR X 3/8"MJ
34	06502036	2	VLV,CHECK,1/2"MOR X 3/8"
35	31329	2	ADAPTOR,1/2"MOR X 1/2"MOR ADJ
36	33492	1	HOSE,1/4" X 138"
37	06510050	2	TRV LCK,METRIPACK COIL
38	06500173	1	HOSE,1/4" X 200"
39	06500149	1	HOSE,1/4" X 220"
40	06500151	1	HOSE,1/4" X 112"
41	06503029	1	TEE,RUN
42	23888	1	BRKT,ACCUMULATOR
43	24300	1	ACCUMULATOR
44	06503072	2	ADAPTER,1/2"MJ X 1/2"BSPP
45	06503073	1	ADAPTER,1/2"MJ X 1/2"BSPP,W/ SEAL

KUB M135GX LRS

# 5 SPOOL CABLE CONTROL MOUNT

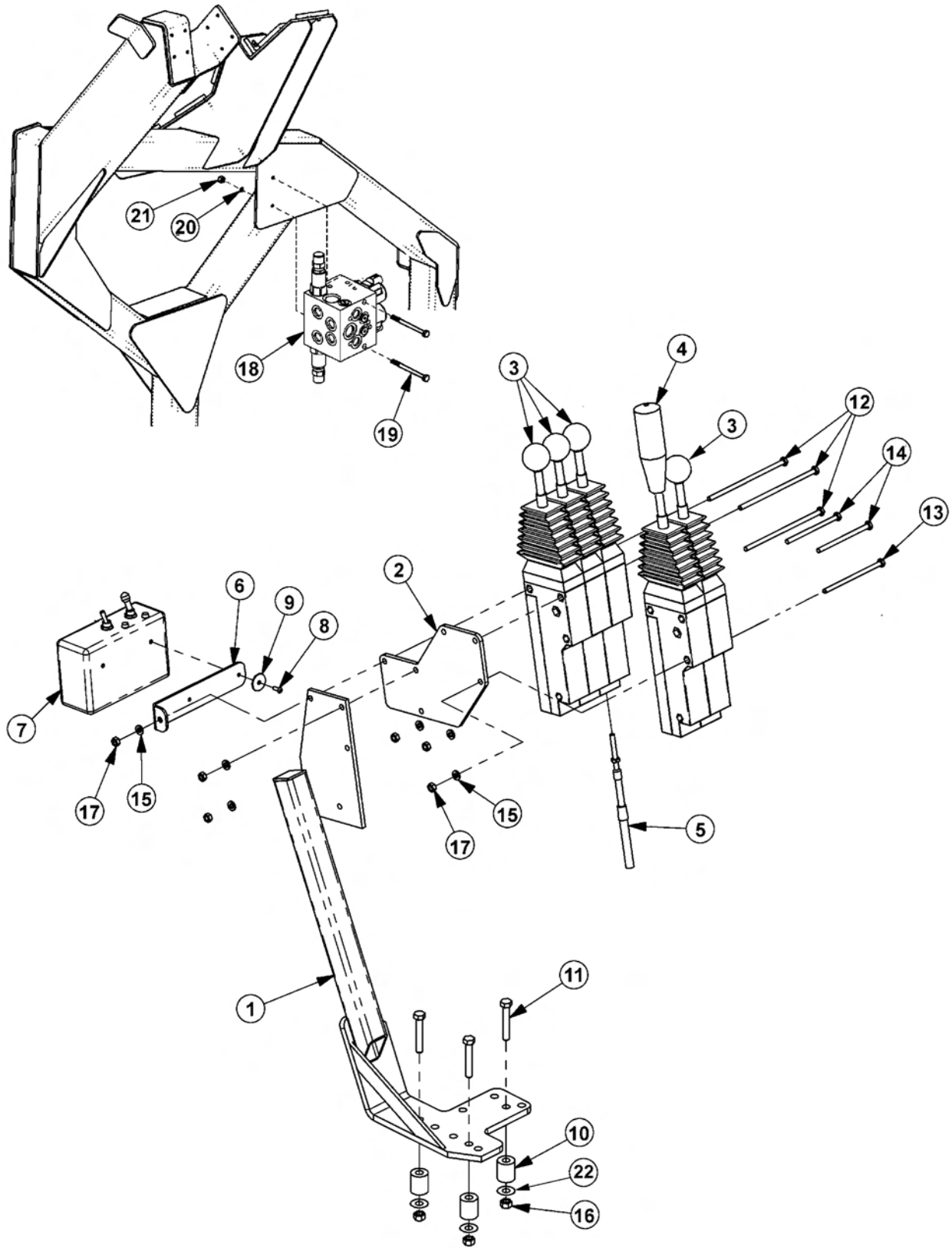

## 5 SPOOL CABLE CONTROL MOUNT

Continued...

ITEM	PART NO.	QTY.	DESCRIPTION
1	23865B	1	CBL CTRL MT BRK
2	06400179	1	MNT,ADPTR,CNTRL BX,2 ROW
3	6T1251	4	CBL CTRL BOX
4	06505023	1	CBL CTRL BOX,W/BUTTON
5	34623	5	CBL,CNTRL,122"
6	34496	1	BRKT,SWITCHBOX,UNI
7	06510049	1	SWITCHBOX ASSY,BOOM,RS
8	6T3951	2	SCREW,MACHINE,8/32 X 1/2"
9	34508	2	WASHER,FENDER,#10
10	27082B	3	SPACER
11	21636	3	CAPSCREW,3/8" X 2-1/2",NC
12	21545	3	CAPSCREW,1/4" X 6",NC
13	21543	1	CAPSCREW,1/4" X 4-1/2",NC
14	21542	2	CAPSCREW,1/4" X 4",NC
15	21986	6	LOCKWASHER,1/4"
16	21627	3	NYLOCK NUT,3/8",NC
17	21525	6	HEX NUT,1/4",NC
18	06502055	1	VLV,SELECTOR,RS
19	21593	2	CAPSCREW,5/16" X 4-1/2",NC
20	21987	2	LOCKWASHER,5/16"
21	21575	2	HEX NUT,5/16",NC
22	6T2615	3	WASHER,FENDER,3/8"

# CABLE (MANUAL) LIFT VALVE - 5 SPOOL

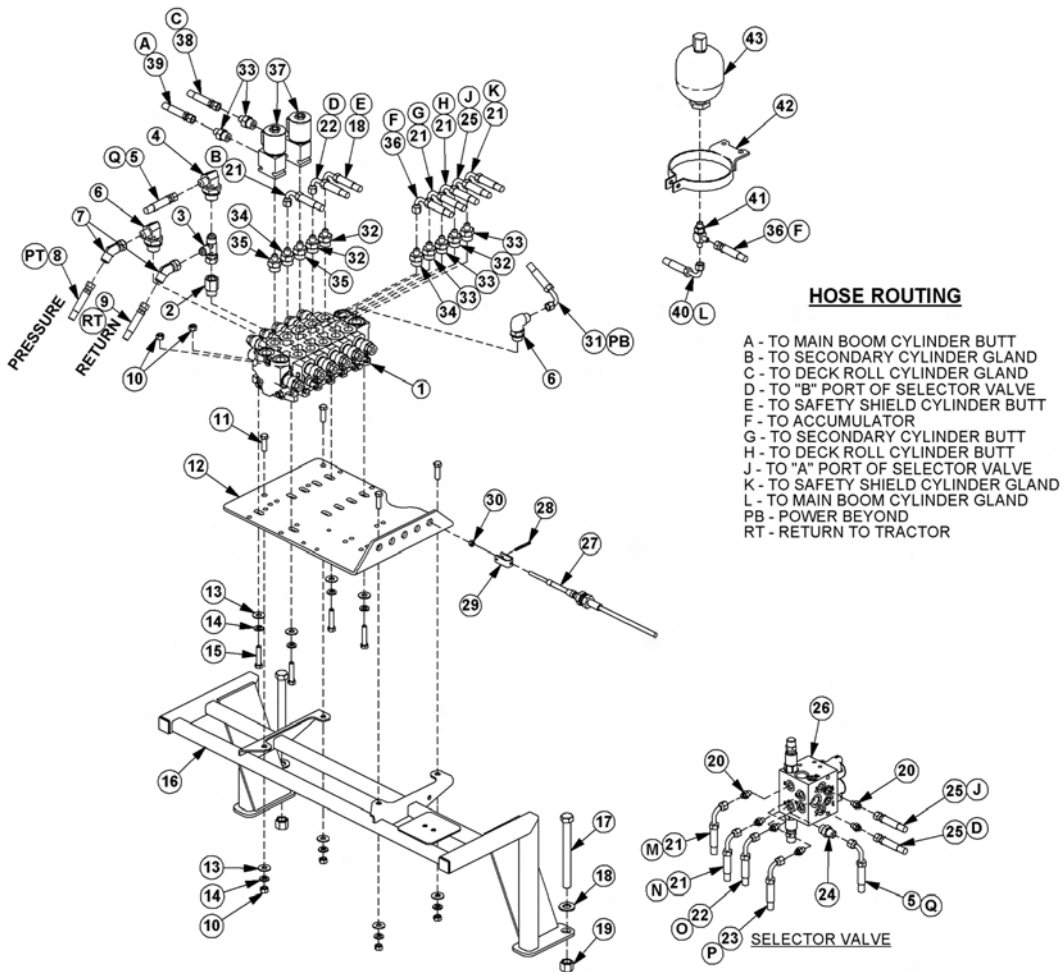

### HOSE ROUTING

- A - TO MAIN BOOM CYLINDER BUTT
- B - TO SECONDARY CYLINDER GLAND
- C - TO DECK ROLL CYLINDER GLAND
- D - TO "B" PORT OF SELECTOR VALVE
- E - TO SAFETY SHIELD CYLINDER BUTT
- F - TO ACCUMULATOR
- G - TO SECONDARY CYLINDER BUTT
- H - TO DECK ROLL CYLINDER BUTT
- J - TO "A" PORT OF SELECTOR VALVE
- K - TO SAFETY SHIELD CYLINDER GLAND
- L - TO MAIN BOOM CYLINDER GLAND
- PB - POWER BEYOND
- RT - RETURN TO TRACTOR

### TRACTOR PRESSURE

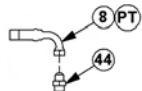

### TRACTOR RETURN

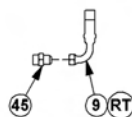

### HOSE ROUTING (CONTINUED)

- M - "A2" PORT TO KNUCKLE CYL GLAND
- N - "B2" PORT TO KNUCKLE CYL BUTT
- O - "A1" PORT TO SWIVEL CYL BUTT
- P - "B1" PORT TO SWIVEL CYL GLAND
- Q - "T" PORT ON SELECTOR VALVE TO "T" PORT ON LIFT VALVE
- PT - TRACTOR PRESSURE TO "P" PORT ON LIFT VALVE

### TRACTOR POWER BEYOND

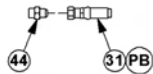

ITEM	PART NO.	QTY.	DESCRIPTION
1	06502078	1	5 SPOOL VALVE (ROTARY MOWERS)
2	32678	1	ADAPTER, 5/8" MOR X 1/2" FOR
3	6T3992	1	RUN, TEE, 1/2" MJ X 1/2" FJX X 1/2" MJ
4	33382	1	ELBOW, 1/2" MOR X 1/2" MJ
5	06500171	1	HOSE, 1/2" X 36"
6	33383	2	ELBOW, 5/8" MOR X 1/2" MJ

## CABLE (MANUAL) LIFT VALVE - 5 SPOOL

Continued...

ITEM	PART NO.	QTY.	DESCRIPTION
7	33483	2	ELBOW,1/2"MJ X 1/2"FXJ 45°
8	06500564	1	HOSE,1/2" X 42"
9	33649	1	HOSE,1/2" X 50"
10	21625	8	HEX NUT,3/8",NC
11	21631	4	CAPSCREW,3/8" X 1-1/4",NC
12	34622	1	PLATE,VALVE,REAR MT
13	22016	8	FLATWASHER,3/8"
14	21988	8	LOCKWASHER,3/8"
15	21632	4	CAPSCREW,3/8" X 1-1/2",NC
16	06340047	1	VALVE MNT
17	06530228	2	CAPSCREW,5/8" X 6-1/2",NC
18	33764	2	FLATWASHER,5/8",SAE
19	21777	2	NYLOCK NUT,5/8",NC
20	32901	6	ADAPTER,3/8"MOR X 3/8"MJ
21	34358	7	HOSE,1/4" X 196"
22	33364	1	HOSE,1/4" X 120"
23	33407	1	HOSE,1/4" X 110"
24	33528	1	ADAPTER,1/2"MOR X 1/2"MJ
25	33744	2	HOSE,1/4" X 34"
26	06502055	1	SELECTOR VALVE
27	34623	5	CBL,CNTRL,122"
28	6T3017	5	ROLLPIN,3/16" X 1"
29	6T4411	5	CLEVIS,3/16"
30	21500	5	HEX NUT,1/4",NF
31	06500478	1	HOSE,1/2" X 34"
32	34396	2	ADAPTOR,.06 RSTRCTR,1/2"MOR X 3/8"MJ
33	33271	6	ADAPTOR,1/2"MOR X 3/8"MJ
34	06502036	2	VLV,CHECK,1/2"MOR X 3/8"
35	31329	2	ADAPTOR,1/2"MOR X 1/2"MOR ADJ
36	33492	1	HOSE,1/4" X 138"
37	06510050	2	TRV LCK,METRIPACK COIL
38	06500173	1	HOSE,1/4" X 200"
39	06500149	1	HOSE,1/4" X 220"
40	06500151	1	HOSE,1/4" X 112"
41	06503029	1	TEE,RUN
42	23888	1	BRKT,ACCUMULATOR
43	24300	1	ACCUMULATOR
44	06503072	2	ADAPTER,1/2"MJ X 1/2"BSPP
45	06503073	1	ADAPTER,1/2"MJ X 1/2"BSPP,W/ SEAL

KUB M135GX LRS

# JOYSTICK AND SWITCH BOX MOUNT

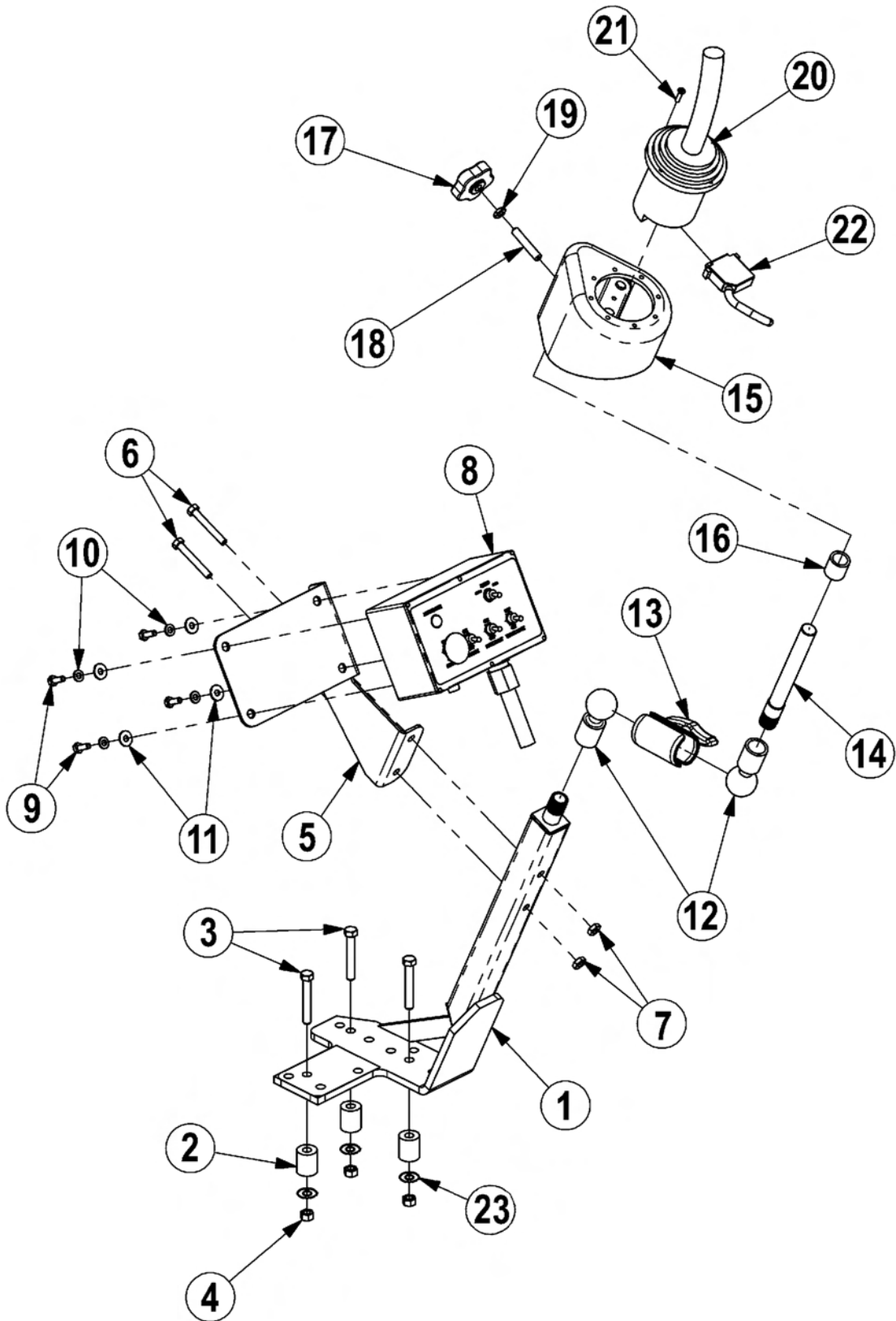



## JOYSTICK AND SWITCH BOX MOUNT

Continued...

ITEM	PART NO.	QTY.	DESCRIPTION
1	06340011	1	MNT,STND,JYSTK
2	27082B	3	SPACER
3	21636	3	CAPSCREW,3/8" X 2-1/2",NC
4	21627	3	NYLOCK NUT,3/8",NC
5	06340015	1	SWITCHBOX MNT,DF
6	21585	2	CAPSCREW,5/16" X 2-1/4",NC
7	21577	2	NYLOCK NUT,5/16",NC
8	06510195	1	SWITCHBOX,BOOM,RS
9	21529	4	CAPSCREW,1/4" X 3/4",NC
10	21986	4	LOCKWASHER,1/4"
11	22014	4	FLATWASHER,1/4"
12	06520041	2	MOUNT,RAM,BALL,1-1/2",NPT
13	06520042	1	MOUNT,RAM,ARM,1.5" X 2.75",SHORT
14	06340010	1	ROD,1/2"NPT X 7",JYSTK
15	35033	1	CAN,JYSTK,CPLT,DF
16	35256	3	BUSHING,NYLON,1"OD,3/4"ID
17	35204	1	KNOB,3/8",NC,INSERT
18	35205	1	SETSCREW,3/8" X 2",NC,KNURLED
19	35206	1	HEX NUT,JAMB,3/8",NC
20	06510046	1	JOYST,4AXIS,RH,RS
21	32829	4	SCREW,MACHINE,10-32 X 3/4,FLATHD
22	33693	1	CBL,EXT,4FT,JOYST,W/SUB-D CONN
23	6T2615	3	WASHER,FENDER,3/8"

# ELECTRONIC PROPORTIONAL LIFT VALVE

## HOSE ROUTING

LS - LOAD SENSE  
 PB - "EF" PORT TO TRACTOR POWER BEYOND  
 PP - PRESSURE FROM PRIORITY VALVE "CF" PORT  
 PT - PRESSURE FROM TRACTOR  
 RS - RETURN FROM SELECTOR VALVE  
 RT - RETURN TO TRACTOR

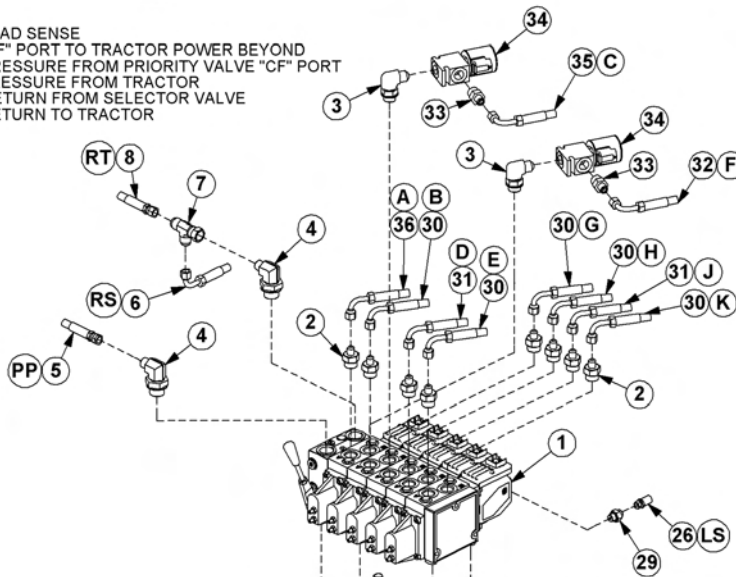

## HOSE ROUTING

A - TO ACCUMULATOR  
 B - TO SECONDARY CYL GLAND  
 C - TO DECK ROLL CYL GLAND  
 D - TO "A" PORT OF SELECTOR VALVE  
 E - TO SAFETY SHIELD CYL GLAND  
 F - TO MAIN BOOM CYL BUTT  
 G - TO SECONDARY CYL BUTT  
 H - TO DECK ROLL CYL BUTT  
 J - TO "B" PORT OF SELECTOR VALVE  
 K - TO SAFETY SHIELD CYL BUTT  
 L - TO MAIN BOOM CYL GLAND

M - "A2" PORT TO KNUCKLE CYL GLAND  
 N - "B2" PORT TO KNUCKLE CY GLAND  
 O - "A1" PORT TO SWIVEL CYL BUTT  
 P - "B1" PORT TO SWIVEL CYL GLAND

## TRACTOR PRESSURE

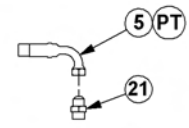

## TRACTOR POWER BEYOND

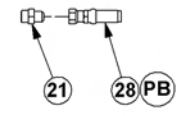

ACCUMULATOR  
 MOUNTED ON  
 MAIN FRAME

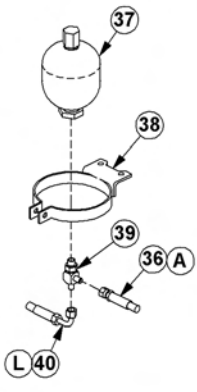

## TRACTOR RETURN

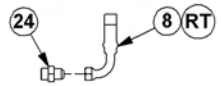

SELECTOR VALVE  
 MOUNTED ON  
 BOOMREST

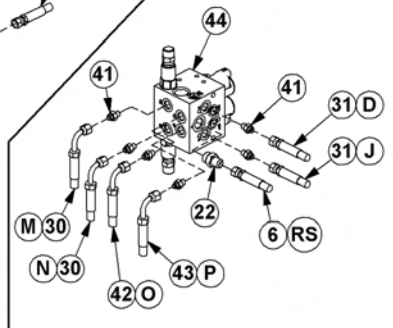

ITEM	PART NO.	QTY.	DESCRIPTION
1	06502097	1	LIFT VALVE,5SP,RS
2	32807	8	ADAPTER,5/8"MOR X 3/8"MJ
3	33383	4	ELBOW,5/8"MOR X 1/2"MJ
4	33294	2	ELBOW,3/4"MOR X 1/2"MJ

## ELECTRONIC PROPORTIONAL LIFT VALVE

Continued...

ITEM	PART NO.	QTY.	DESCRIPTION
5	06500564	2	HOSE,1/2" X 42"
6	06500171	1	HOSE,1/2" X 36"
7	6T3992	1	RUN TEE,1/2"MJ X 1/2"FJX X 1/2"MJ
8	33649	1	HOSE,1/2" X 50"
9	21631	4	CAPSCREW,3/8" X 1-1/4",NC
10	34622	1	PLATE,VALVE,REAR MT
11	21987	6	LOCKWASHER,5/16"
12	21579	6	CAPSCREW,5/16" X 3/4",NC
13	06340047	1	VALVE MOUNT
14	22016	4	FLATWASHER,3/8"
15	21988	4	LOCKWASHER,3/8"
16	21625	4	HEX NUT,3/8",NC
17	21577	1	NYLOCK NUT,5/16",NC
18	21777	2	NYLOCK NUT,5/8",NC
19	33764	2	FLATWASHER,5/8,SAE
20	06530228	2	CAPSCREW,5/8" X 6-1/2",NC
21	06503072	2	ADAPTER,1/2"MJ X 1/2"BSPP
22	33528	2	ADAPTER,1/2"MOR X 1/2"MJ
23	06502102	1	VALVE,PRIORITY
24	06503073	1	ADAPTER,1/2"MJ X 1/2"BSPP,W/ SEAL
25	06503057	1	ADAPTER,1/4"MOR X 3/8"MJ
26	33734	1	HOSE,1/4" X 34"
27	21586	1	CAPSCREW,5/16" X 2-1/2",NC
28	06500478	1	HOSE,1/2" X 34"
29	33392	1	ADAPTER,5/16"MOR X 3/8",MJ
30	34358	7	HOSE,1/4" X 196"
31	33744	2	HOSE,1/4" X 34"
32	06500149	1	HOSE,1/4" X 220"
33	33271	2	ADAPTER,1/2"MOR X 3/8"MOR
34	06510050	2	TRAVEL LOCK
35	34358	1	HOSE,1/4" X 196"
36	33492	1	HOSE,1/4" X 138"
37	24300	1	ACCUMULATOR
38	23888	1	BRKT,ACCUMULATOR
39	06503029	1	TEE,RUN
40	06500151	1	HOSE,1/4" X 112"
41	32901	6	ADAPTER,3/8"MOR X 3/8"MJ
42	33364	1	HOSE,1/4" X 120"
43	33562	1	HOSE,1/4" X 130"
44	06502055	1	VALVE,SELECTOR

KUB M135GX LRS

# BULKHEAD HOSE ASSEMBLY - REAR STOW

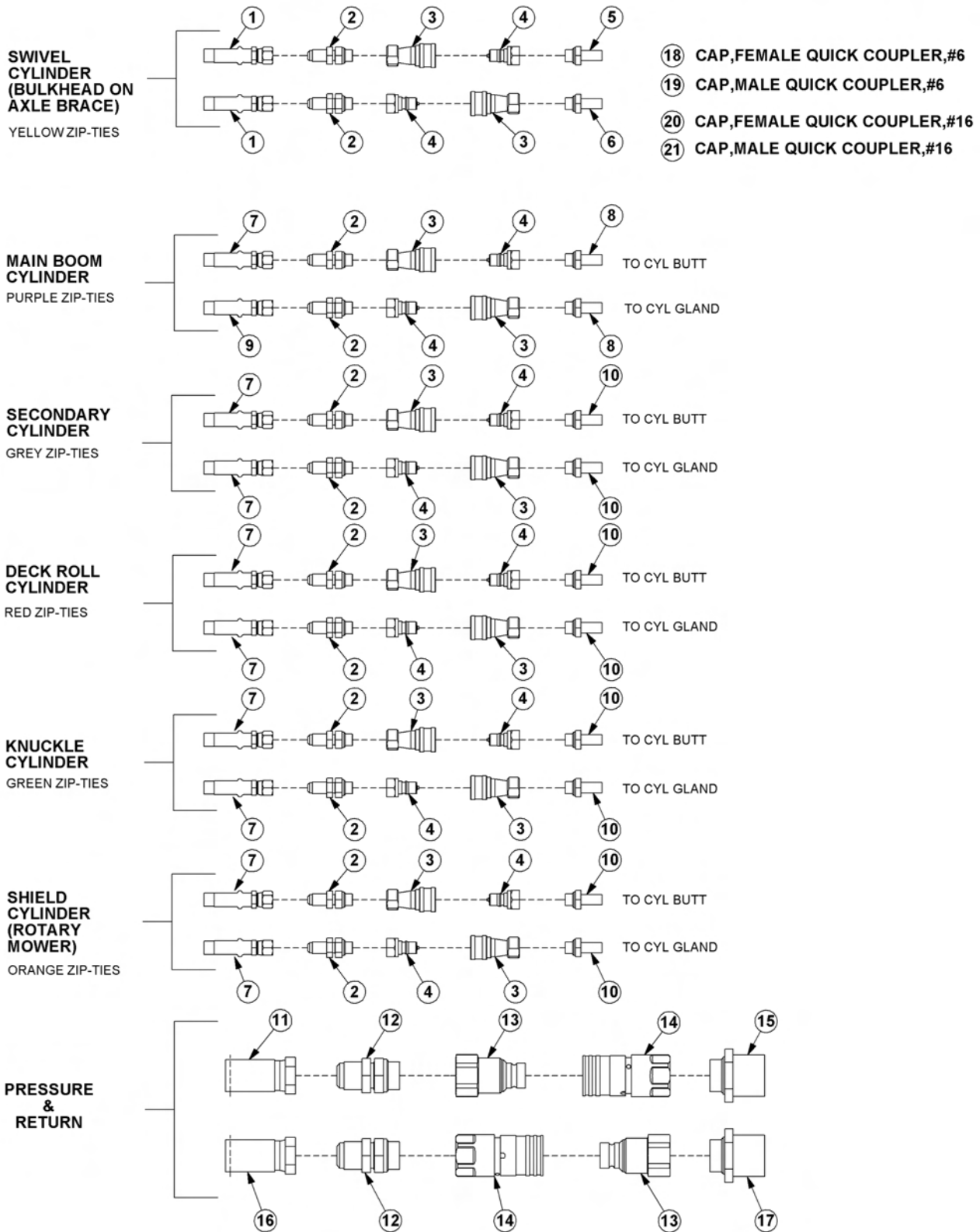

## BULKHEAD HOSE ASSEMBLY - REAR STOW

Continued...

ITEM	PART NO.	QTY.	DESCRIPTION
1	33407	2	HOSE,1/4" X 110" (FROM LIFT VALVE)
2	33289	12	FITTING,BULKHEAD,3/8"
3	06503051	12	QUICK COUPLER,1/4",FEMALE
4	06503052	12	QUICK COUPLER,1/4",MALE
5	06500527	1	HOSE,1/4" X 32" (FROM AXLE BULKHEAD TO CYL GLAND)
6	06500528	1	HOSE,1/4" X 32" (FROM AXLE BULKHEAD TO CYL BUTT)
7	06500511	9	HOSE,1/4" X 161" (FROM LIFT VALVE)
8	06500666	2	HOSE,1/4" X 94" (FROM BULKHEAD)
9	06500150	1	HOSE,1/4" X 142" (FROM ACCUMULATOR)
10	06500667	8	HOSE,1/4" X 105" (FROM BULKHEAD)
11	06500529	1	HOSE,1" X 23" (FROM BRAKE VALVE PRESSURE)
12	33287	2	FITTING,BULKHEAD,1"
13	06503028	2	QUICK COUPLER,1",MALE
14	06503027	2	QUICK COUPLER,1",FEMALE
15	06500664	1	HOSE,1" X 81 (TO MOTOR PRESSURE)
16	06500530	1	HOSE,1" X 27" (FROM BRAKE VALVE RETURN)
17	06500665	1	HOSE,1" X 79" (TO MOTOR RETURN)
18	06520408	12	CAP,FEMALE QUICK COUPLER,#6
19	06520407	12	CAP,MALE QUICK COUPLER,#6
20	06505096	2	CAP,FEMALE QUICK COUPLER,#16
21	06505097	2	CAP,MALE QUICK COUPLER,#16

## BULKHEAD HOSE ASSEMBLY - SIDE FLAIL

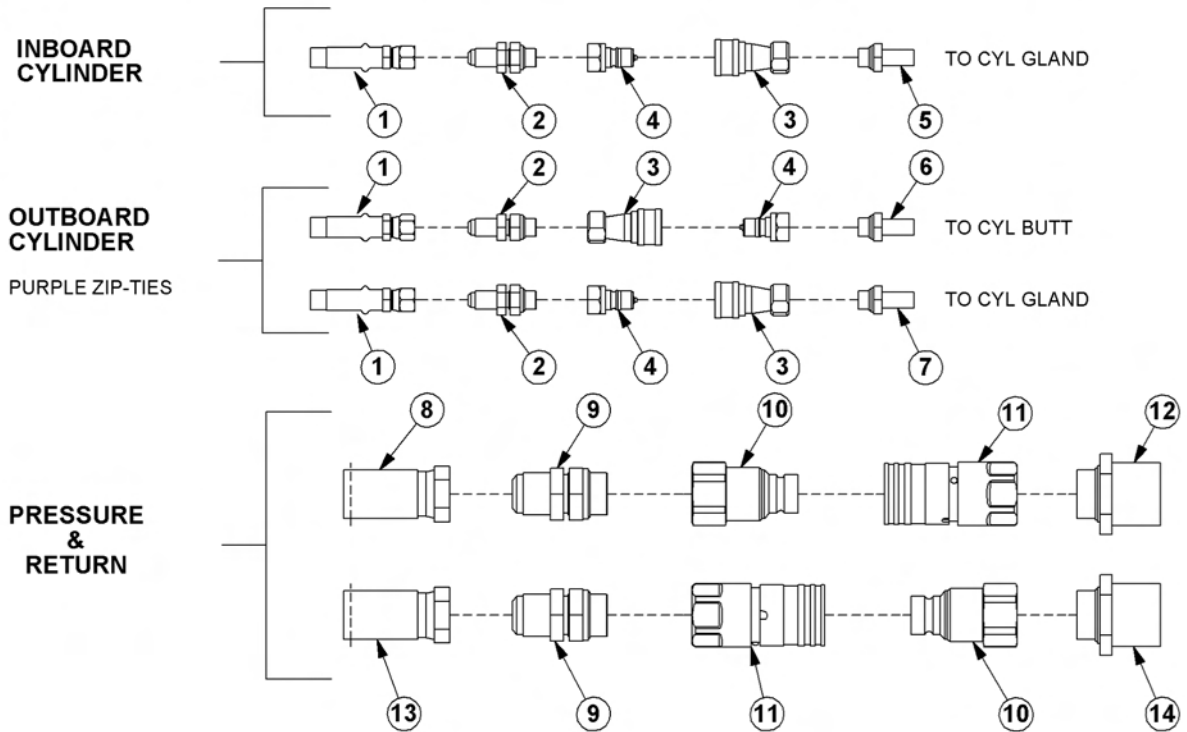

- ⑮ CAP,FEMALE QUICK COUPLER,#6
- ⑯ CAP,MALE QUICK COUPLER,#6
- ⑰ CAP,FEMALE QUICK COUPLER,#16
- ⑱ CAP,MALE QUICK COUPLER,#16

## BULKHEAD HOSE ASSEMBLY - SIDE FLAIL

Continued...

ITEM	PART NO.	QTY.	DESCRIPTION
1	06500511	3	HOSE,1/4" X 161" (FROM LIFT VALVE OR TRACTOR REMOTES)
2	33289	3	FITTING,BULKHEAD,3/8"
3	06503051	3	QUICK COUPLER,1/4",FEMALE
4	06503052	3	QUICK COUPLER,1/4",MALE
5	06500513	1	HOSE,1/4" X 38" (FROM BULKHEAD)
6	06500514	1	HOSE,1/4" X 56" (FROM BULKHEAD)
7	06500515	1	HOSE,1/4" X 70" (FROM BULKHEAD)
8	06500529	1	HOSE,1" X 23" (FROM BRAKE VALVE PRESSURE)
9	33287	2	FITTING,BULKHEAD,1"
10	06503028	2	QUICK COUPLER,1",MALE
11	06503027	2	QUICK COUPLER,1",FEMALE
12	06500523	1	HOSE,1" X 92 (TO MOTOR PRESSURE)
13	06500530	1	HOSE,1" X 27" (FROM BRAKE VALVE RETURN)
14	06500522	1	HOSE,1" X 85" (TO MOTOR RETURN)
15	06520408	3	CAP,FEMALE QUICK COUPLER,#6
16	06520407	3	CAP,MALE QUICK COUPLER,#6
17	06505096	2	CAP,FEMALE QUICK COUPLER,#16
18	06505097	2	CAP,MALE QUICK COUPLER,#16

CABLE (MANUAL) LIFT VALVE BREAKDOWN - 06502078

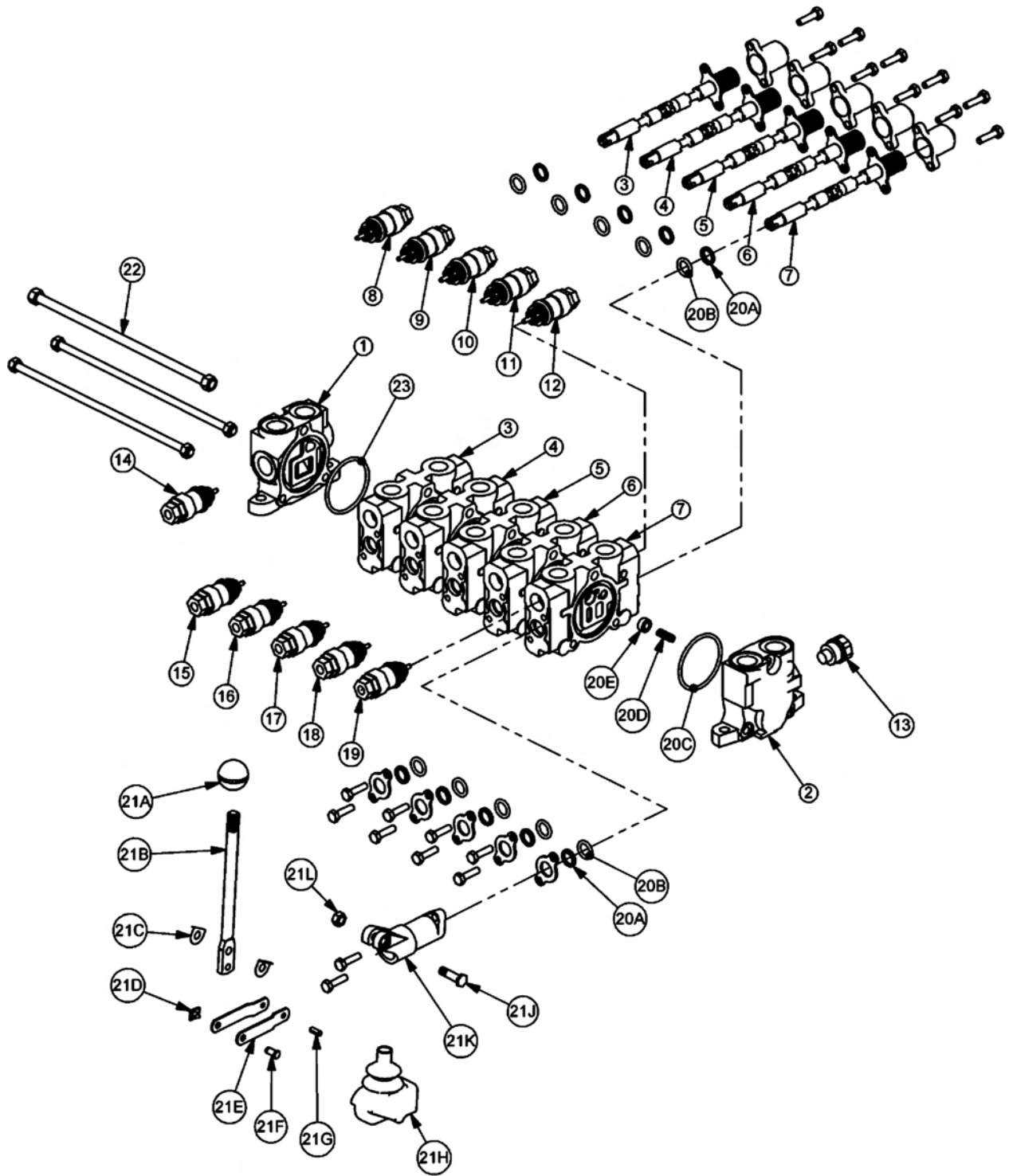



## CABLE (MANUAL) LIFT VALVE BREAKDOWN - 06502078

Continued...

ITEM	PART NO.	QTY.	DESCRIPTION
1	TB1017S	1	INLET END COVER
2	TB1702	1	END COVER,POWER BEYOND
3	TB1017P	1	VALVE SECTION (SINGLE ACTING,SPRING DETENT)
4	TB1017N	1	VALVE SECTION (DOUBLE ACTING,CENTER SPRING)
5	TB1017N	1	VALVE SECTION (DOUBLE ACTING,CENTER SPRING)
6	TB1017Q	1	VALVE SECTION (DOUBLE ACTING,SPRING METERED)
7	TB1017N	1	VALVE SECTION (DOUBLE ACTING, CENTER SPRING)
8	TF4212	1	RELIEF VALVE,200 PSI
9	TB1017K	1	RELIEF VALVE,2150 PSI
10	TB1017J	1	RELIEF VALVE,1800 PSI
11	06502089	1	RELIEF VALVE,2400 PSI
12	22588	1	RELIEF VALVE,500 PSI
13	TB1017M	1	SHUT OFF PLUG
14	06502085	1	RELIEF VALVE,3000 PSI
15	06502085	1	RELIEF VALVE,3000 PSI
16	TB1017F	1	RELIEF VALVE,1500 PSI
17	TB1017F	1	RELIEF VALVE,1500 PSI
18	06502120	1	RELIEF VALVE,2150 PSI
19	22588	1	RELIEF VALVE,500 PSI
20	TB1017A	5	VALVE SEAL KIT (FOR ONE SECTION)
20A	-----	2	WIPER
20B	-----	2	O-RING SMALL
20C	-----	1	O-RING LARGE
20D	-----	1	SHUTTLE DISC
20E	-----	1	SPRING
21	TB1017L	5	LEVER KIT (FOR ONE SECTION)
21A	-----	1	LEVER KNOB
21B	-----	1	LEVER
21C	-----	2	LEVER WASHER
21D	-----	1	LEVER CLIP
21E	-----	2	LINKAGE
21F	-----	1	LEVER PIN
21G	-----	1	ROLL PIN
21H	-----	1	LEVER BOOT
21J	-----	1	LEVER BOLT
21K	-----	1	LEVER DUST COVER
21L	-----	1	LEVER NUT
22	TB1017V	5	TIE ROD KIT
23	24214	1	O-RING, LARGE

CABLE (MANUAL) LIFT VALVE BREAKDOWN - 06502079

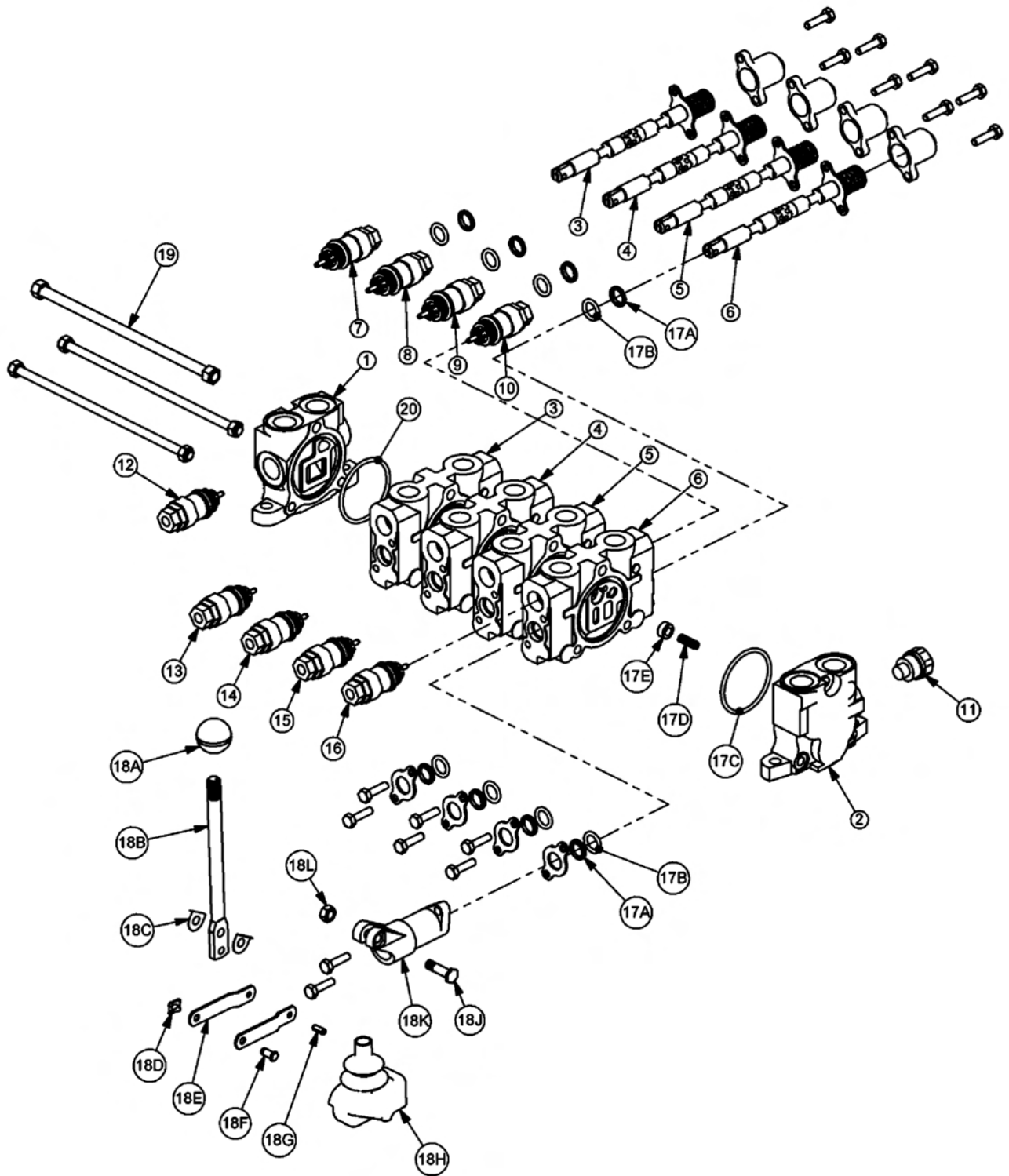

## CABLE (MANUAL) LIFT VALVE BREAKDOWN - 06502079

Continued...

ITEM	PART NO.	QTY.	DESCRIPTION
1	TB1017S	1	INLET END COVER
2	TB1702	1	END COVER,POWER BEYOND
3	TB1017N	1	VALVE SECTION (DOUBLE ACTING,CENTER SPRING)
4	TB1017N	1	VALVE SECTION (DOUBLE ACTING,CENTER SPRING)
5	TF3009	1	VALVE SECTION (DOUBLE ACTING,DETENT - FLOAT)
6	TB1017Q	1	VALVE SECTION (DOUBLE ACTING,SPRING METERED)
7	TF4212	1	RELIEF VALVE,200 PSI
8	TB1017K	1	RELIEF VALVE,2150 PSI
9	TB1017J	1	RELIEF VALVE,1800 PSI
10	06502089	1	RELIEF VALVE,2400 PSI
11	TB1017M	1	SHUT OFF PLUG
12	06502085	1	RELIEF VALVE,3000 PSI
13	06502085	1	RELIEF VALVE,3000 PSI
14	TB1017F	1	RELIEF VALVE,1500 PSI
15	TB1017F	1	RELIEF VALVE,1500 PSI
16	06502120	1	RELIEF VALVE,2100 PSI
17	TB1017A	4	VALVE SEAL KIT (FOR ONE SECTION)
17A	-----	2	WIPER
17B	-----	2	O-RING SMALL
17C	-----	1	O-RING LARGE
17D	-----	1	SHUTTLE DISC
17E	-----	1	SPRING
18	TB1017L	4	LEVER KIT (FOR ONE SECTION)
18A	-----	1	LEVER KNOB
18B	-----	1	LEVER
18C	-----	2	LEVER WASHER
18D	-----	1	LEVER CLIP
18E	-----	2	LINKAGE
18F	-----	1	LEVER PIN
18G	-----	1	ROLL PIN
18H	-----	1	LEVER BOOT
18J	-----	1	LEVER BOLT
18K	-----	1	LEVER DUST COVER
18L	-----	1	LEVER NUT
19	TB1017U	4	TIE ROD KIT
20	24214	1	O-RING,LARGE

CABLE (MANUAL) LIFT VALVE BREAKDOWN - 06502094

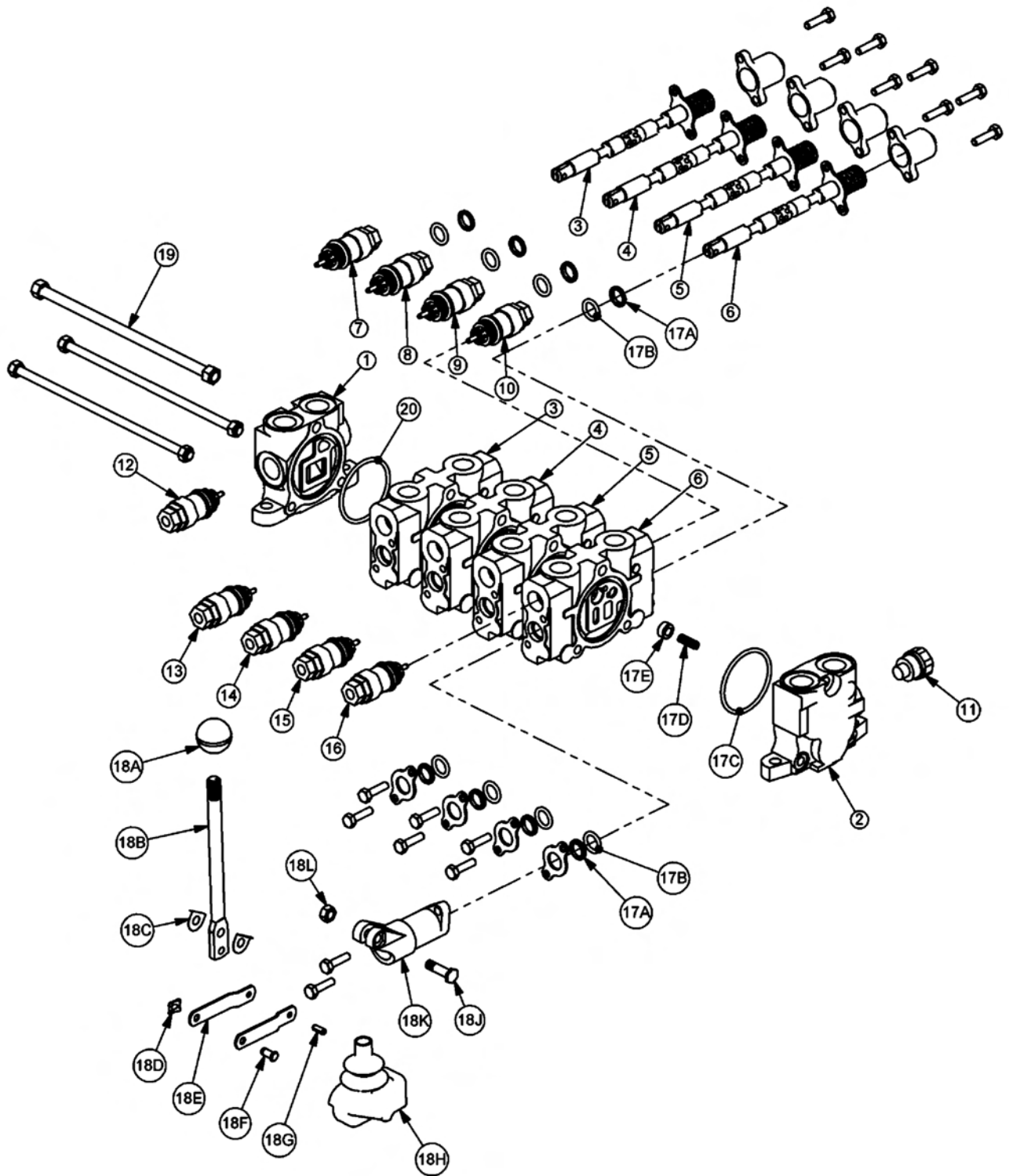

## CABLE (MANUAL) LIFT VALVE BREAKDOWN - 06502094

Continued...

ITEM	PART NO.	QTY.	DESCRIPTION
1	TB1017S	1	INLET END COVER
2	TB1702	1	END COVER,POWER BEYOND
3	TB1017P	1	VALVE SECTION (SINGLE ACTING,SPRING DETENT)
4	TB1017N	1	VALVE SECTION (DOUBLE ACTING,CENTER SPRING)
5	TB1017N	1	VALVE SECTION (DOUBLE ACTING,CENTER SPRING)
6	TB1017Q	1	VALVE SECTION (DOUBLE ACTING,SPRING METERED)
7	N/A	1	N/A
8	TB1017K	1	RELIEF VALVE,2150 PSI
9	TB1017J	1	RELIEF VALVE,1800 PSI
10	06502089	1	RELIEF VALVE,2400 PSI
11	TB1017M	1	SHUT OFF PLUG
12	06502037	1	RELIEF VALVE,2600 PSI
13	06502003	1	RELIEF VALVE,2500 PSI
14	TB1017F	1	RELIEF VALVE,1500 PSI
15	TB1017F	1	RELIEF VALVE,1500 PSI
16	06502120	1	RELIEF VALVE,2100 PSI
17	TB1017A	4	VALVE SEAL KIT (FOR ONE SECTION)
17A	-----	2	WIPER
17B	-----	2	O-RING SMALL
17C	-----	1	O-RING LARGE
17D	-----	1	SHUTTLE DISC
17E	-----	1	SPRING
18	TB1017L	4	LEVER KIT (FOR ONE SECTION)
18A	-----	1	LEVER KNOB
18B	-----	1	LEVER
18C	-----	2	LEVER WASHER
18D	-----	1	LEVER CLIP
18E	-----	2	LINKAGE
18F	-----	1	LEVER PIN
18G	-----	1	ROLL PIN
18H	-----	1	LEVER BOOT
18J	-----	1	LEVER BOLT
18K	-----	1	LEVER DUST COVER
18L	-----	1	LEVER NUT
19	TB1017U	4	TIE ROD KIT
20	24214	1	O-RING,LARGE

# POLYCARBONATE SAFETY WINDOW

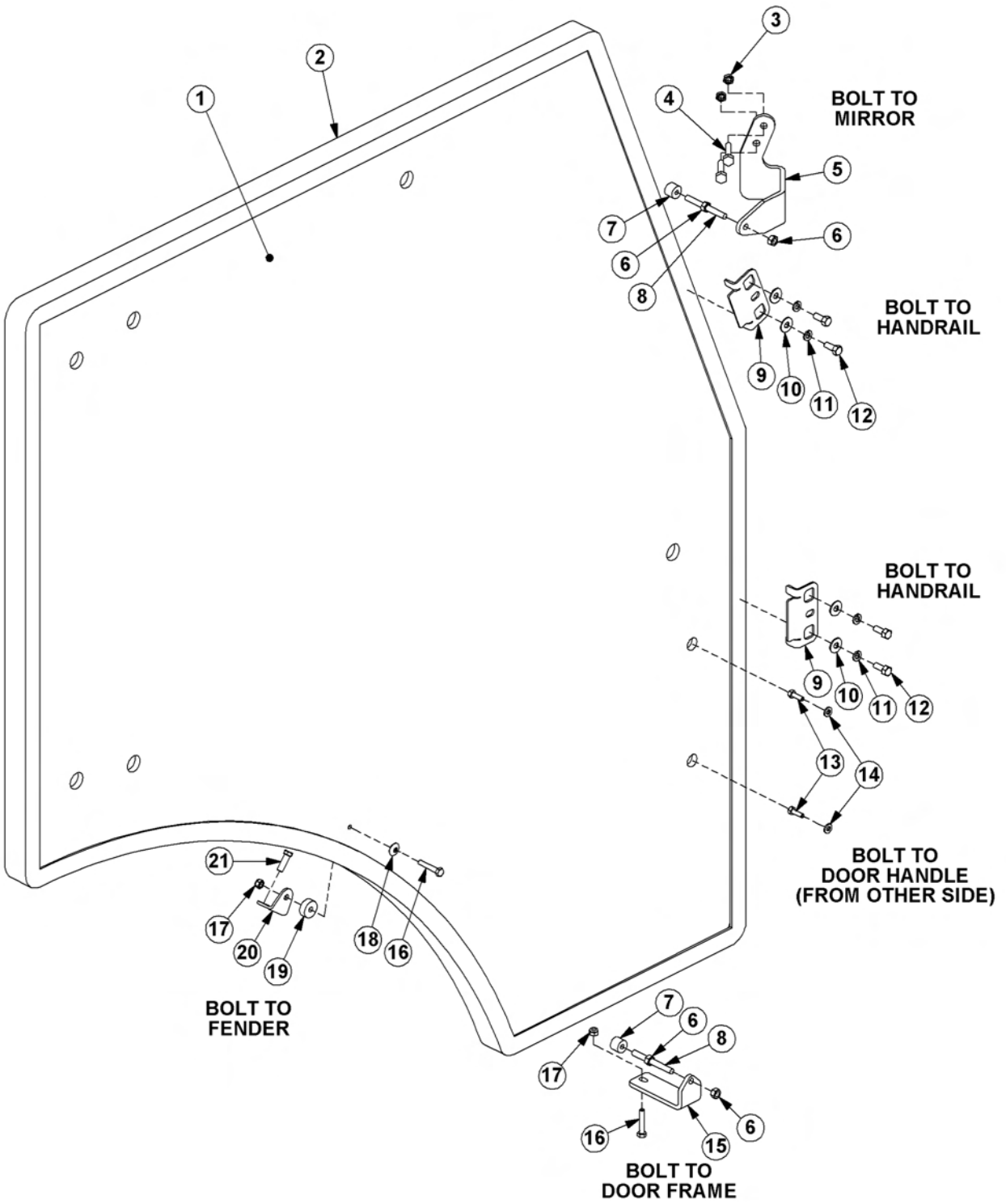

## POLYCARBONATE SAFETY WINDOW

Continued...

ITEM	PART NO.	QTY.	DESCRIPTION
1	06490043	1	POLYCARB,PANORAMIC
2	31965	17	TRIM SEAL (FEET)
3	-----	-	HEX NUT *EXISTING HARDWARE
4	06530502	2	CAPSCREW,8MM X 40MM,1.25P
5	06411623	1	BRKT,SFTY SCRN, TOP
6	21575	4	HEX NUT,5/16",NC
7	33477	2	VIBRATION ISOLATOR
8	33478	2	ROD,THREADED,3"
9	06520040	2	BRKT,POLY,RETAIN
10	22015	4	FLATWASHER,5/16"
11	6T2619	4	LOCKWASHER,8MM
12	27506	4	CAPSCREW,6MM X 20MM,1.0P
13	06530501	2	CAPSCREW,6MM X 25MM,1.0P
14	21986	2	LOCKWASHER,1/4"
15	06411624	1	BRKT,SFTY SCRN,BOTTOM
16	21532	2	CAPSCREW,1/4" X 1-1/2",NC
17	21727	2	NYLOCK NUT,1/4",NC
18	06537001	1	WASHER,RUBBERIZED,1/4",CONICAL
19	06537000	1	WASHER,NEOPRENE,1/4"
20	06410392	1	MNT,SMALL,POLY
21	28583	1	CAPSCREW,8MM X 25MM,1.25P

## WHEEL WEIGHT - CAST IRON RIMS

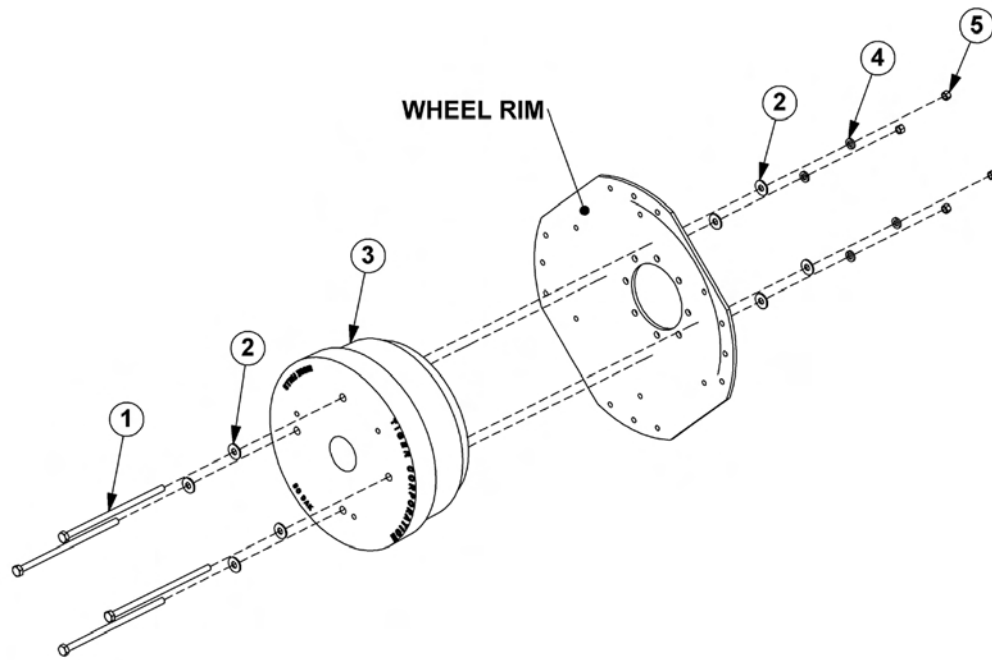

ITEM	PART NO.	QTY.	DESCRIPTION
1	31455	4	CAPSCREW,3/4" X 17"
2	22021	8	FLATWASHER,3/4"
3	TB3236	1	WHL WT,1300 LB
4	21993	4	LOCKWASHER,3/4"
5	21825	4	HEX NUT,3/4",NC



## WHEEL WEIGHT - STEEL RIMS

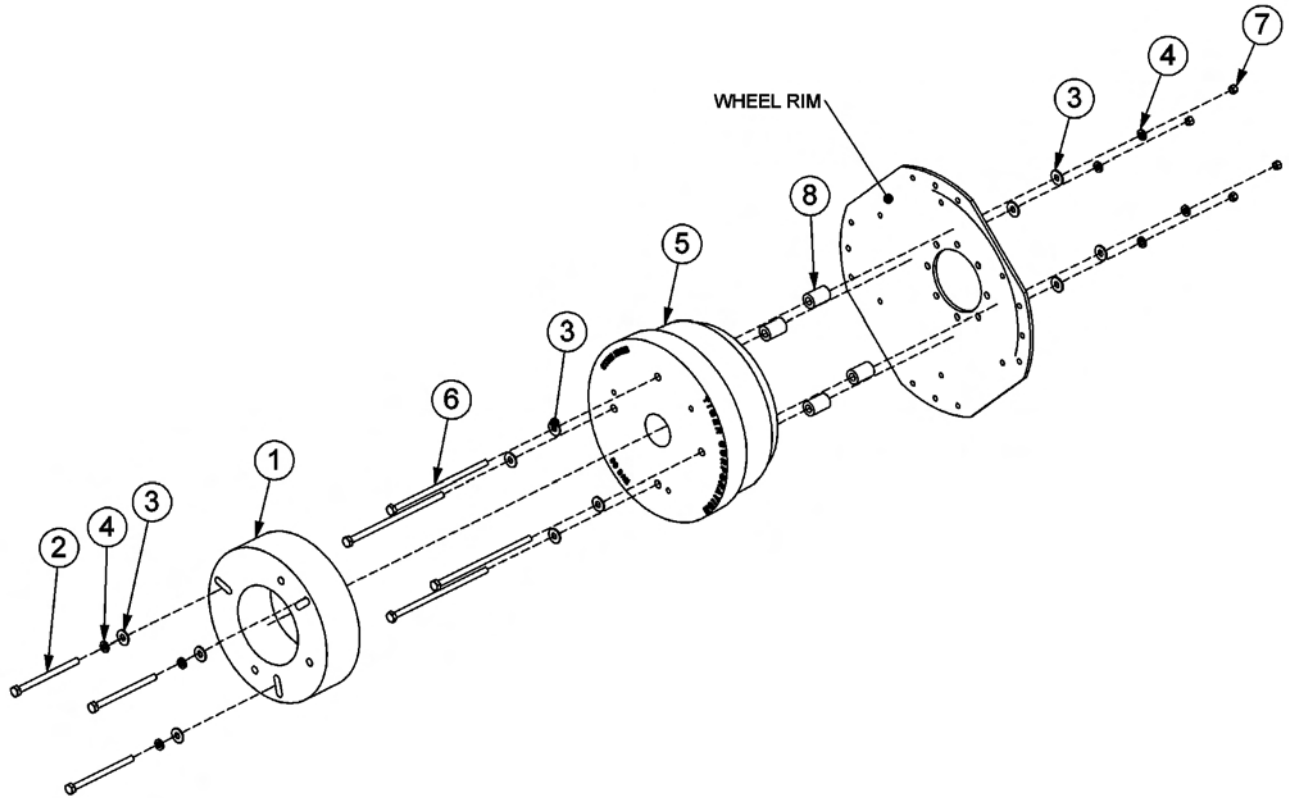

ITEM	PART NO.	QTY.	DESCRIPTION
1	30687	1	WHL WT,500 LB
2	21848	3	CAPSCREW,3/4" X 11",NC
3	22021	11	FLATWASHER,3/4"
4	21993	7	LOCKWASHER,3/4"
5	06770008	1	WHL WT,1300 LB,TAPPED
6	31455	4	CAPSCREW,3/4" X 17"
7	21825	4	HEX NUT,3/4",NC
8	TB3278	4	SPACER

**NOTES**

**NOTES**

# COMMON LEGAL REAR STOW

## PARTS SECTION

## PART NAME INDEX

PARTS ORDERING GUIDE.....	4
BENGAL BRUTE HOSE ROUTING.....	5
LEGAL REAR STOW BOOM ASSY.....	6
LEGAL REAR STOW BOOM HYD ASSY.....	8
BOOMREST - BENGAL BRUTE.....	10
BOOMREST - PANTHER.....	12
LEGAL REAR STOW RTRY PIVOT ASSY.....	14
LEGAL REAR STOW FLAIL PIVOT ASSY.....	16
50IN ROTARY MOWER ASSEMBLY.....	18
60IN ROTARY MOWER ASSEMBLY.....	20
50IN ROTARY KNIVES AND DISH.....	22
50IN ROTARY BLADE BAR AND KNIVES.....	23
60IN ROTARY KNIVES AND DISH.....	24
60IN ROTARY BLADE BAR AND KNIVES.....	25
50IN FLAIL DRIVE ASSEMBLY.....	26
50IN FLAIL MOWER ASSEMBLY.....	28
50IN FLAIL MOWER ASSY, PASS-THROUGH KNIVES.....	30
63IN FLAIL DRIVE ASSEMBLY.....	32
63IN FLAIL MOWER ASSEMBLY.....	34
3IN X 10IN WELDED CYLINDER BREAKDOWN.....	36
3IN X 18IN WELDED CYLINDER BREAKDOWN.....	37
3-1/2IN X 20IN WELDED CYLINDER BREAKDOWN.....	38
4IN X 9IN WELDED CYLINDER BREAKDOWN.....	39
4IN X 20IN WELDED CYLINDER BREAKDOWN.....	40
NOTES 1.....	41
COOLER ASSEMBLY.....	42
ROTARY MOWER SPINDLE ASSEMBLY.....	44
PUMP AND GRILL GUARD OPTIONS.....	46
RESERVOIR TANK FILTER ASSEMBLY.....	47
5 SPOOL ELECTRONIC VALVE - BENGAL BRUTE.....	48
5 SPOOL ELECTRONIC VALVE - PANTHER.....	50
FRONT HYDRAULIC PUMP.....	52
50IN AND 60IN ROTARY MOTOR BREAKDOWN.....	54
50IN AND 63IN FLAIL MOTOR BREAKDOWN.....	56
MANUAL LIFT VALVE SWITCH BOX.....	58
MANUAL LIFT VALVE SCHEMATIC.....	59
ELECTRONIC LIFT VALVE SWITCH BOX.....	60
ELECTRONIC LIFT VALVE SCHEMATIC - REAR STOW.....	61
ELECTRONIC LIFT VALVE WIRING DIAGRAM.....	62
BOOM TRAVEL LOCK.....	63

COMMON LRS

## PART NAME INDEX

SELECTOR VALVE SCHEMATIC.....	64
BRAKE VALVE ASSEMBLY.....	65
BRAKE VALVE HYDRAULIC SCHEMATIC.....	66
HYDRAULIC TROUBLESHOOTING GUIDE.....	67
ELECTRICAL TROUBLESHOOTING GUIDE.....	68
TROUBLESHOOTING.....	69
TROUBLESHOOTING - CONTINUED.....	70
CLEAN CUTTER HEAD.....	71
CLEAN CUTTER ASSEMBLY.....	72
CLEAN CUTTER OPERATION.....	73
CLEAN CUTTER OPERATION - CONTINUED.....	74
CLEAN CUTTER MAINTENANCE.....	75
CLEAN CUTTER BLADE AND TEETH PARTS.....	76
CARBIDE TIP REPLACEMENT.....	77
NOTES 2.....	78
FIRE SUPPRESSION SYSTEM.....	79
FIRE SUPPRESSION 3-POINT MOUNT.....	80
FIRE SUPPRESSION FRONT MOUNT.....	82
FIRE SUPPRESSION SYSTEM ELECTRICAL SCHEMATIC.....	84
WETCUT.....	85
WETCUT 50 GALLON TANK - 3PNT MOUNT.....	86
WETCUT 100 OR 150 GALLON TANK - 3PNT MOUNT.....	87
WETCUT 3PNT PLUMBING - 50IN MOWERS.....	88
WETCUT 3PNT PLUMBING - LARGE MOWERS.....	90
WETCUT FRONT PLUMBING - 50IN MOWERS.....	92
WETCUT FRONT PLUMBING - LARGE MOWERS.....	94
WETCUT 50IN SPRAYER HEAD ASSEMBLY.....	96
WETCUT 60IN SPRAYER HEAD ASSEMBLY.....	98
WETCUT CABLES.....	100

## PARTS ORDERING GUIDE

The following instructions are offered to help eliminate needless delay and error in processing purchase orders for the equipment in this manual.

1. The Parts Section is prepared in logical sequence and grouping of parts that belong to the basic machine featured in this manual. Part Numbers and Descriptions are given to help locate the parts and quantities required.
2. The Purchase Order must indicate the **Name and Address** of the person or organization ordering the parts, **who should be charged**, and if possible, the **serial number of the machine** for which the parts are being ordered.
3. The purchase order must clearly list the **quantity of each part**, the complete and correct **part number**, and the basic **name of the part**.
4. The manufacturer reserves the right to substitute parts where applicable.
5. Some parts may be unlisted items which are special production items not normally stocked and are subject to special handling. Request a quotation for such parts before sending a purchase order.
6. The manufacturer reserves the right to change prices without prior notice.

NOTE: When ordering replacement decals, refer to the part numbers and descriptions listed in the safety section in the front of this manual.



For maximum safety and to guarantee optimum product reliability, always use genuine **Tiger** replacement parts. The use of inferior replacement parts may cause premature or catastrophic failure which could result in serious injury or death.

Direct any questions regarding parts to:

**Tiger Corporation**  
3301 N. Louise Ave.  
Sioux Falls, SD 57107  
1-800-843-6849  
1-605-336-7900

## BENGAL BRUTE HOSE ROUTING

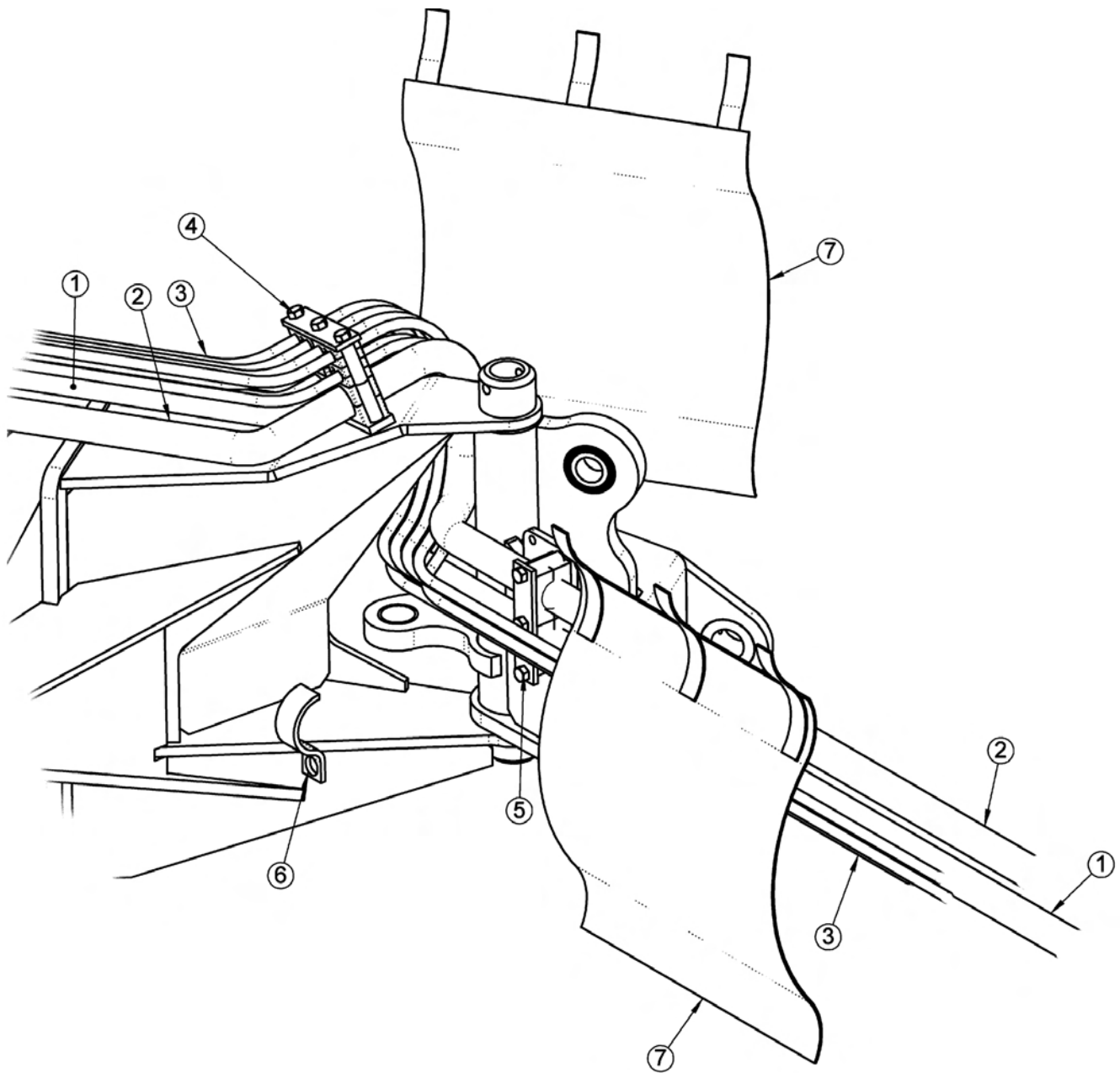

ITEM	PART NO.	QTY.	DESCRIPTION
1	-----	1	1" HOSE TO MAIN BOOM LOWER TUBE
2	-----	1	1" HOSE TO MAIN BOOM UPPER TUBE
3	-----	6	1/4" HOSE TO MAIN BOOM
4	06505085	1	CLAMP KIT
5	35131	1	CLAMP KIT
6	TB3012	1	CLAMP
7	06505021	2	HOSE COVER

COMMON LRS

# LEGAL REAR STOW BOOM ASSY

## NOTES

1. IMPORTANT: ALIGN GREASE HOLE IN BEARING (ITEMS 4 & 5) WITH GREASE ZERK IN BOOM. MAINTAIN ALIGNMENT DURING BEARING INSTALLATION
2. "X" JOINTS HAVE TWO BEARINGS

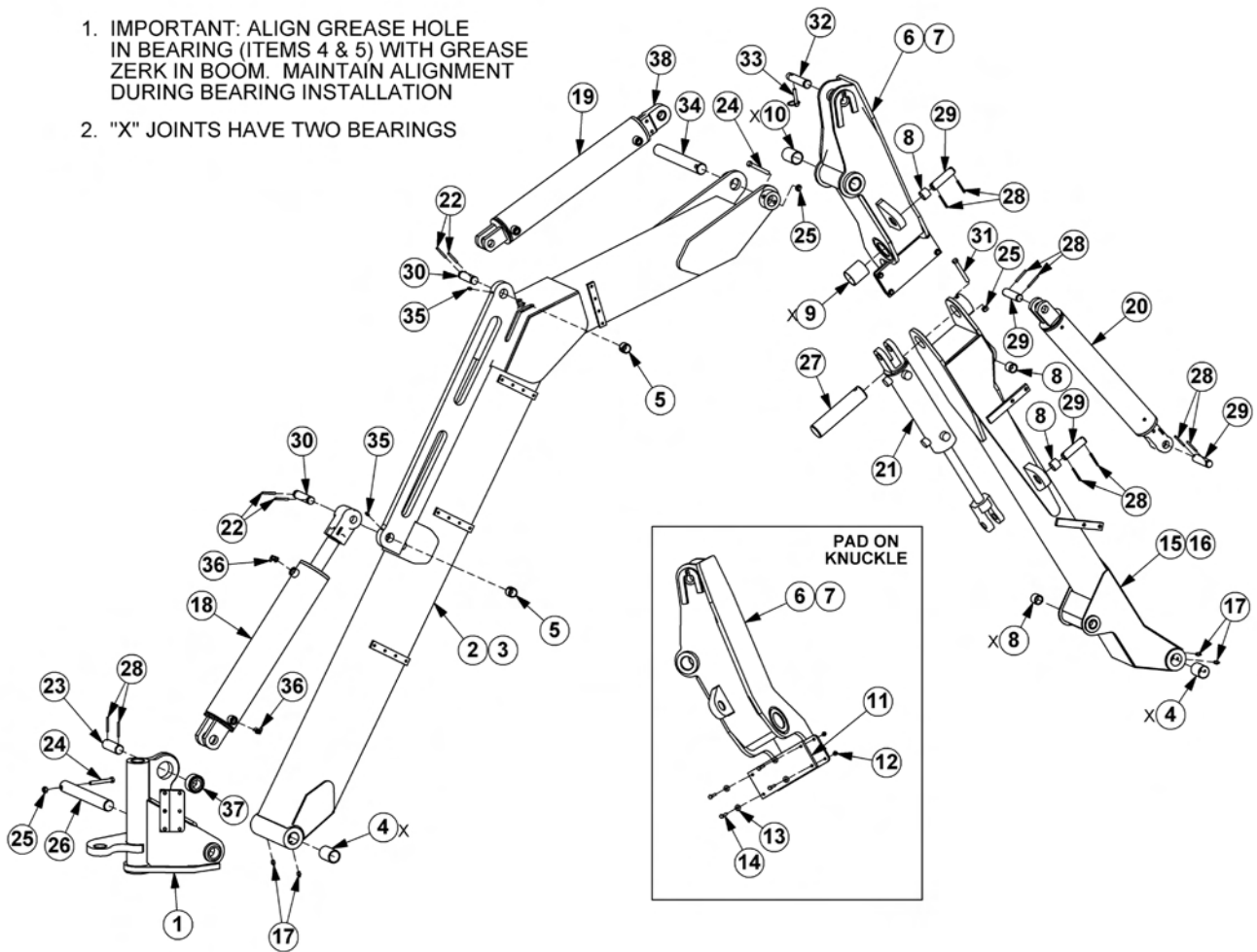



## LEGAL REAR STOW BOOM ASSY

Continued...

ITEM	PART NO.	QTY.	DESCRIPTION
1	06700017	-	SWIVEL ASSY *REFER TO TRACTOR MOUNT KIT
2	06700031	1	MAIN BOOM ARM ASSY
3	06310013	1	MAIN BOOM WLDMNT
4	32321	4	BUSHING,1-1/2ID X 2
5	TB3010	2	BUSHING,IID
6	06700036	1	KNUCKLE BOOM ARM ASSY
7	06310007	1	KNUCKLE BOOM WLDMNT
8	06520076	4	BUSHING,IID X 1
9	06520077	2	BUSHING,2ID X 1
10	06520411	2	BUSHING,1-1/2ID X 2-1/2
11	06520080	1	BOOM STOP PAD
12	21527	4	NYLOCK NUT,1/4,NC
13	22014	4	FLATWASHER,1/4
14	21532	4	CAPSCREW,1/4 X 1-1/2
15	06700037	1	SECONDARY BOOM ARM ASSY
16	06310008	1	SECONDARY BOOM WLDMNT
17	6T3711	4	GREASE ZERK,1/8"NPT
18	06501022	1	CYLINDER,4 X 20
19	06501024	1	CYLINDER,3-1/2 X 20
20	06501023	1	CYLINDER,3 X 18
21	06501021	1	CYLINDER,3 X 10
22	06537021	4	ROLLPIN,5MM
23	06420100	1	PIN,1-1/4 X 3-5/8
24	21688	2	CAPSCREW,7/16 X 3-1/4,NC
25	21677	3	NYLOCK NUT,7/16,NC
26	06420022	1	PIN,1-1/2 X 12-3/4
27	06420017	1	PIN,1-3/4 X 8-9/16
28	TB1023	10	ROLLPIN,7/32
29	06420014	4	PIN,1 X 3-5/8
30	TB1033	2	PIN,1 X 3-1/2
31	21689	1	CAPSCREW,7/16 X 3-1/2
32	TB1036	1	PIN,1 X 4-11/16
33	TF1143	1	LYNCH PIN,7/16 X 2
34	06420015	1	PIN,1-1/2 X 11-3/4
35	6T3702	2	GREASE ZERK,1/4
36	32810	2	ELBOW,1/2ORB X 3/8MJ90 ADJ
37	-----	-	SPHERICAL BEARING
38	TB3033	1	CLEVIS W/ SPHERICAL BEARING

COMMON LRS

# LEGAL REAR STOW BOOM HYD ASSY

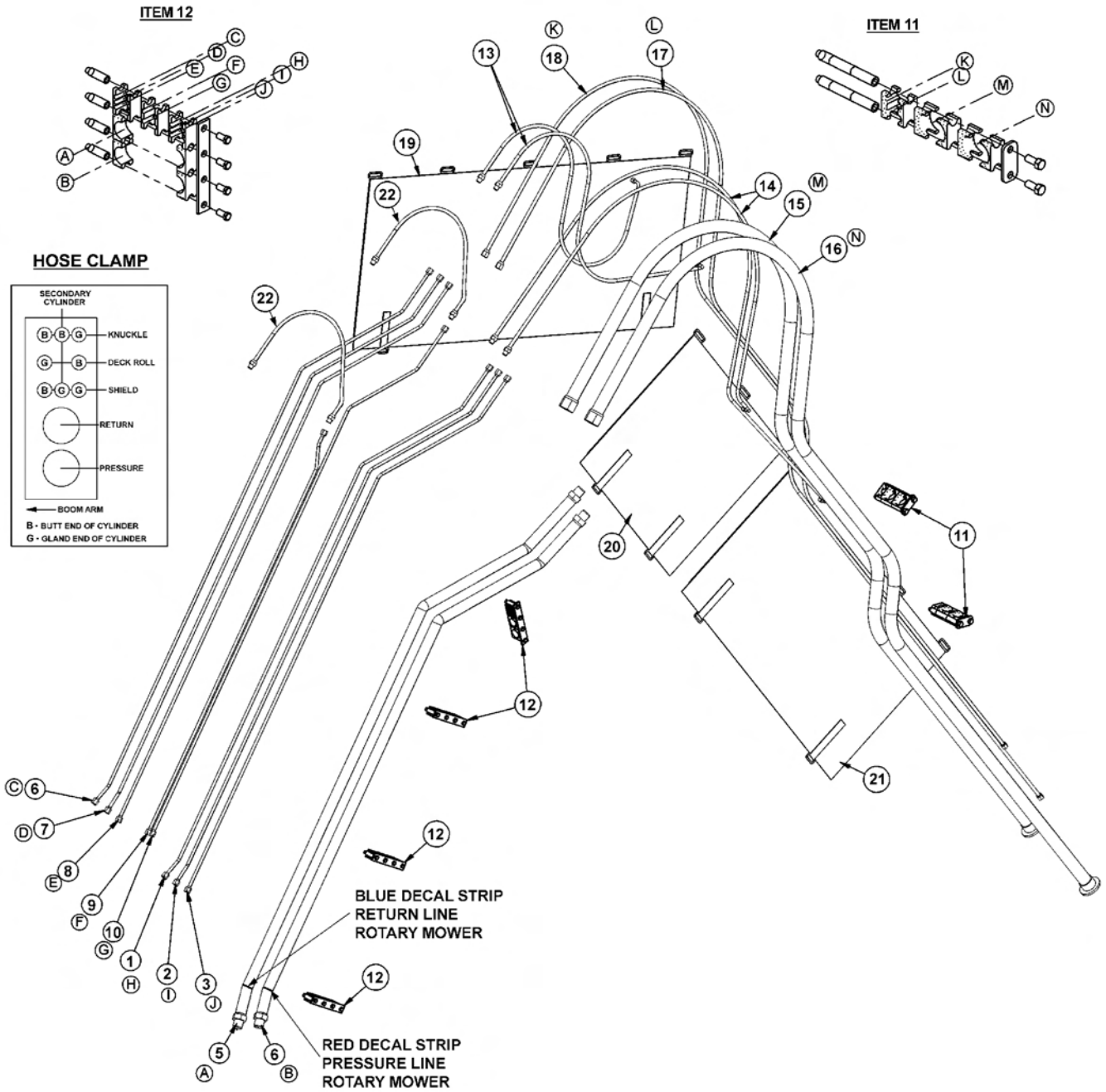

## LEGAL REAR STOW BOOM HYD ASSY

Continued...

ITEM	PART NO.	QTY.	DESCRIPTION
1	06506020	1	PREFORMED TUBE #8
2	06506019	1	PREFORMED TUBE #7
3	06506018	1	PREFORMED TUBE #6
4	06506022	1	PREFORMED TUBE #9
5	06506021	1	PREFORMED TUBE #10
6	06506015	1	PREFORMED TUBE #3
7	06506014	1	PREFORMED TUBE #2
8	06506013	1	PREFORMED TUBE #1
9	06506017	1	PREFORMED TUBE #5
10	06506016	1	PREFORMED TUBE #4
11	06505024	2	CLAMP KIT
12	06505019	4	CLAMP KIT
13	06500152	2	HOSE, 1/4" X 66"
14	06500153	2	HOSE, 1/4" X 70"
15	06500154	1	HOSE, 1" X 141"
16	06500155	1	HOSE, 1" X 126"
17	06500156	1	HOSE, 1/4" X 143"
18	06500157	1	HOSE, 1/4" X 154"
19	06505020	1	HOSE WRAP
20	06505021	1	HOSE WRAP
21	06505022	1	HOSE WRAP
22	34052	2	HOSE, 1/4" X 20"

COMMON LRS

# BOOMREST - BENGAL BRUTE

**NOTE:** FOR TRANSPORTING ON A FLATBED, THE FLAIL HEAD MUST BE STOWED IN THE UPPER MOST POSITION, THE 50" ROTARY MUST BE STOWED IN THE LOWER POSITION AND THE 60" ROTARY MUST BE STOWED IN THE LOWER POSITION ON THE STOP (06310017)

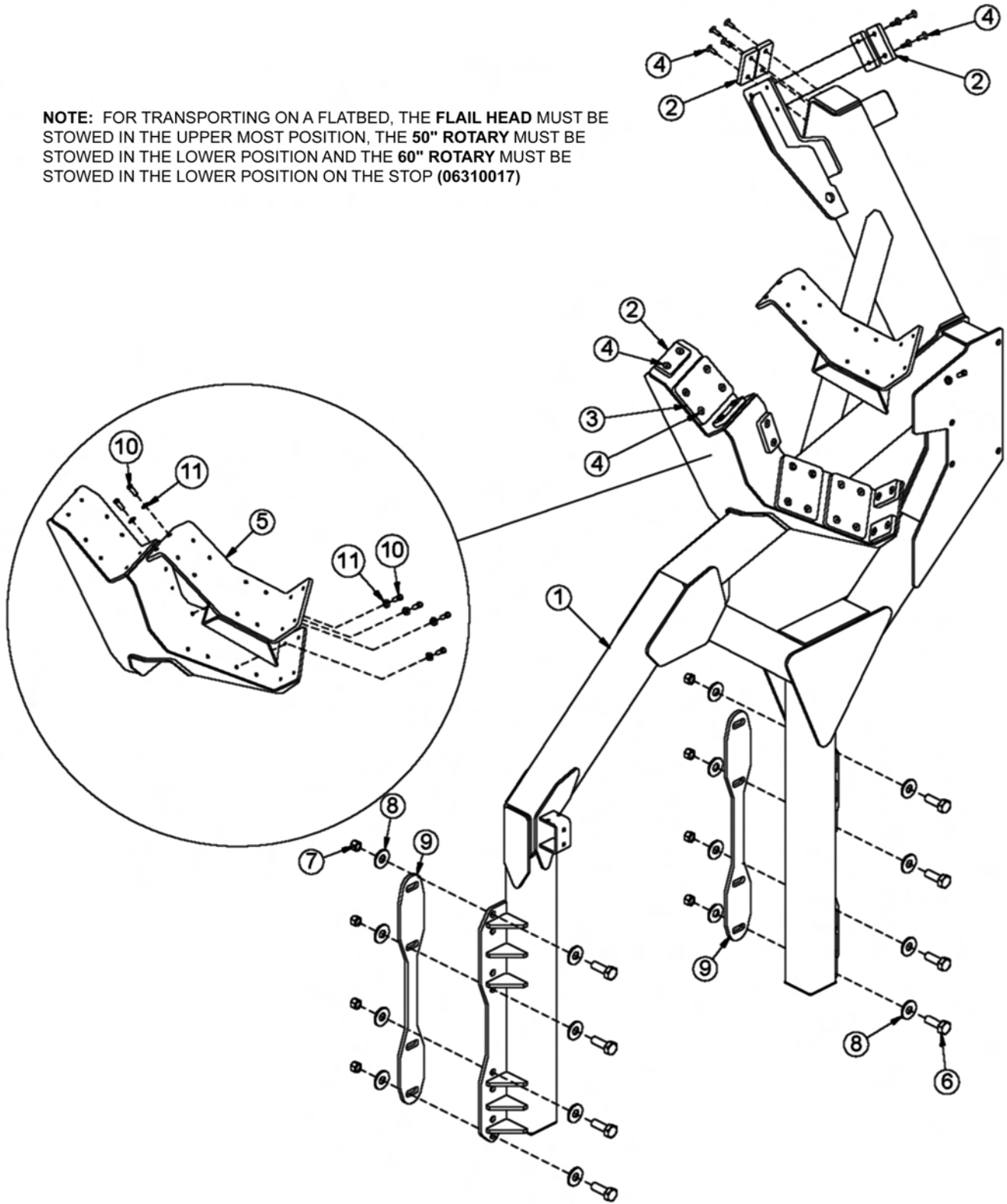

## BOOMREST - BENGAL BRUTE

Continued...

ITEM	PART NO.	QTY.	DESCRIPTION
1	06310039	1	BOOMREST,LRS
2	06520078	9	STRIP,REST,SEC,1
2a	06520078	2	STRIP,REST,SEC,1 *FLAIL MOWER
2b	06520078	3	STRIP,REST,SEC,1 *50" RTRY MOWER
2c	06520078	2	STRIP,REST,SEC,1 *60" RTRY MOWER
3	06520079	3	STRIP,REST,SEC,2
3a	06520079	1	STRIP,REST,SEC,2 *FLAIL MOWER
3b	06520079	2	STRIP,REST,SEC,2 *50" RTRY MOWER
3c	06520079	2	STRIP,REST,SEC,2 *60" RTRY MOWER
4	28734	30	CAPSCREW,FLT/SKT HD,3/8" X 1",NC
4a	28734	8	CAPSCREW,FLT/SKT HD,3/8" X 1",NC *FLAIL MOWER
4b	28734	14	CAPSCREW,FLT/SKT HD,3/8" X 1",NC *50" RTRY MOWER
4c	28734	14	CAPSCREW,FLT/SKT HD,3/8" X 1",NC *60" RTRY MOWER
5	06310017	1	STOP,TRB60,RS *60" RTRY MOWER ONLY
6	21782	8	CAPSCREW,5/8" X 1-3/4",NC
7	21777	8	NYLOCK NUT,5/8",NC
8	33764	16	FLATWASHER,5/8",SAE
9	-----	-	AXLE BRACE *REFER TO TRACTOR MOUNT KIT
10	21630	6	CAPSCREW,3/8" X 1",NC
11	21988	6	LOCKWASHER,3/8"

COMMON LRS

# BOOMREST - PANTHER

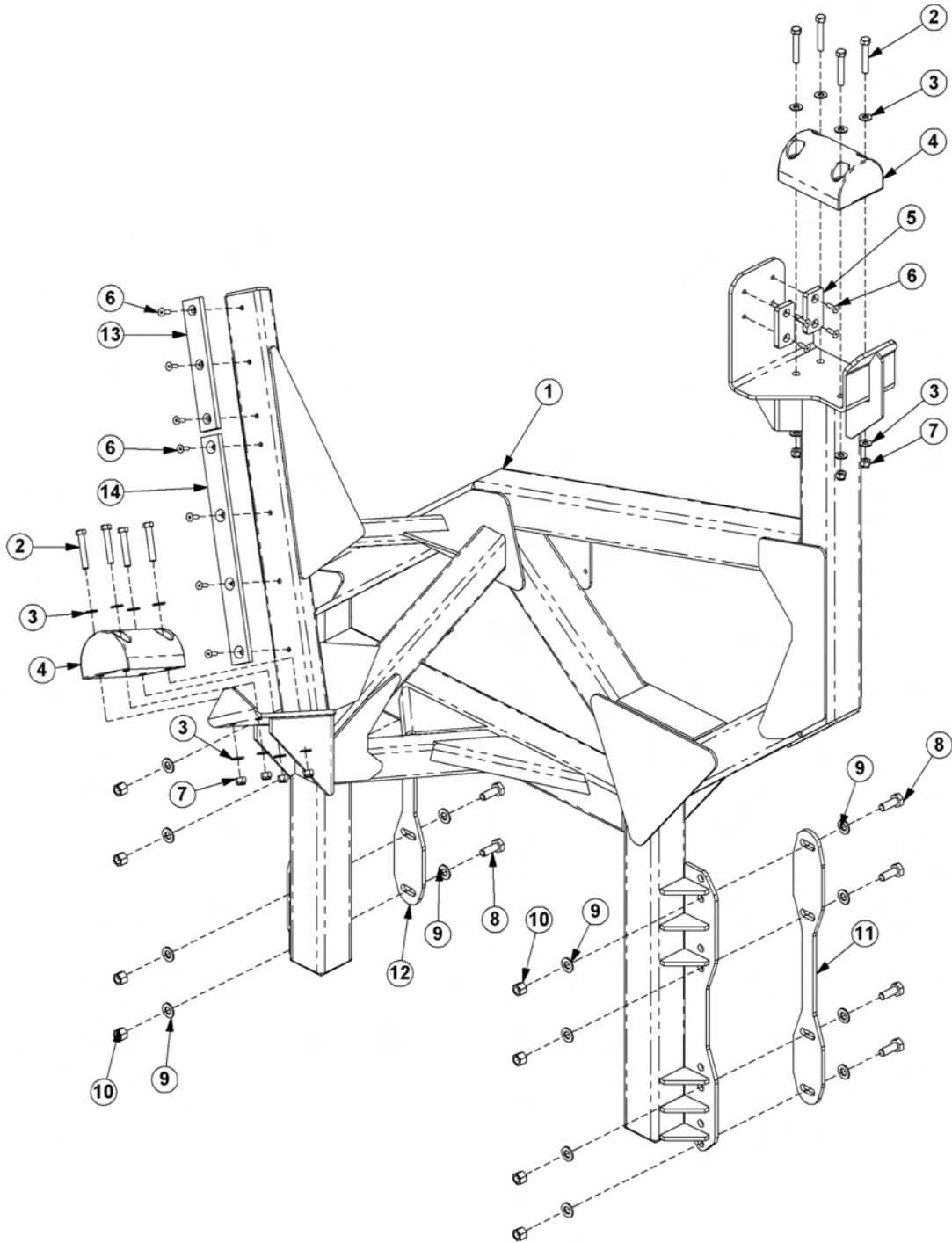

COMMON LRS

## BOOMREST - PANTHER

Continued...

ITEM	PART NO.	QTY.	DESCRIPTION
1	06310086	1	BOOMREST,PANTHER,LRS
2	21737	8	CAPSCREW,1/2" X 3",NC
3	06533004	16	FLATWASHER,1/2",SAE
4	06520436	2	BUMPER,RND
5	06520078	2	STRIP,REST
6	28734	11	CAPSCREW,3/8" X 1",SKT HD,NC
7	21727	8	NYLOCK NUT,1/2",NC
8	21782	8	CAPSCREW,5/8" X 1-3/4",NC
9	33764	16	FLATWASHER,5/8",SAE
10	21777	8	NYLOCK NUT,5/8",NC
11	-----	-	AXLE BRACE,RIGHT *REFER TO TRACTOR MOUNT KIT
12	-----	-	AXLE BRACE,LEFT *REFER TO TRACTOR MOUNT KIT
13	32686	1	WEARPAD,LONG
14	32671	1	GUIDE,PLASTIC

COMMON LRS

# LEGAL REAR STOW RTRY PIVOT ASSY

MOTOR SERIAL TAG ON  
SHIELD SIDE OF MOWER  
(MOTOR OFFSET TOWARDS BACK)

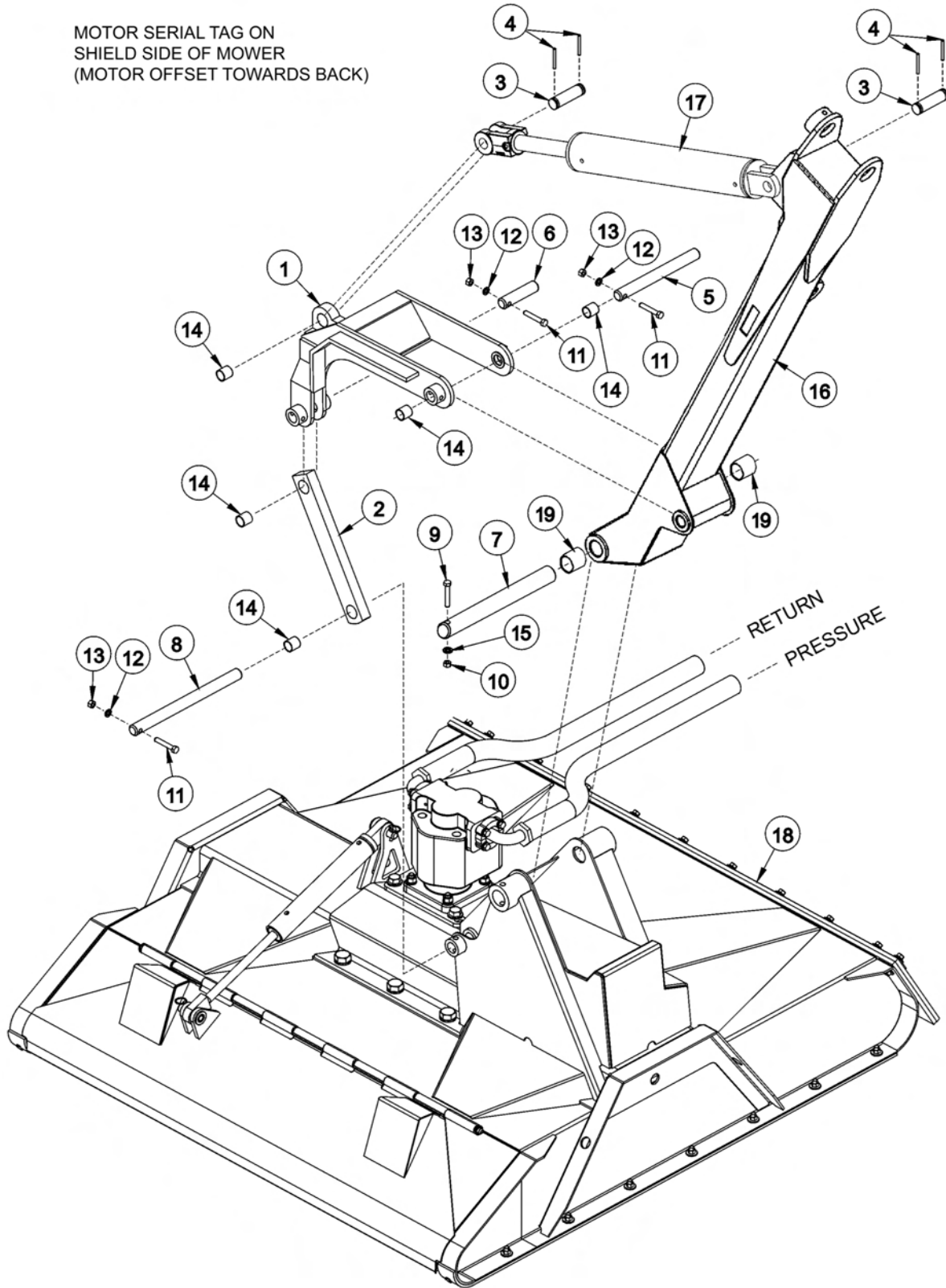



## LEGAL REAR STOW RTRY PIVOT ASSY

Continued...

ITEM	PART NO.	QTY.	DESCRIPTION
1	06700016	1	PIVOT ASSEMBLY
2	06700015	1	PIVOT ARM ASSEMBLY
3	06420014	2	PIN, CLEVIS
4	TB1023	4	ROLL PIN
5	06420019	1	PIN
6	06420020	1	PIN
7	06420016	1	PIN
8	06420021	1	PIN
9	21688	1	CAPSCREW 7/16" X 2-3/4", NC
10	21675	1	HEX NUT, 7/16", NC
11	21635	3	CAPSCREW 3/8" X 2 1/4"
12	21988	3	LOCKWASHER 3/8"
13	21625	3	HEX NUT 3/8"
14	06520076	5	BEARING, 1ID X 1
15	21989	1	LOCKWASHER 7/16"
16	-----	-	SECONDARY BOOM *REFER TO BOOM ARM ASSY
17	-----	-	CYLINDER *REFER TO BOOM ARM ASSY
18	-----	-	ROTARY MOWER HEAD *REFER TO ROTARY DECK
19	06520411	2	BEARING, 1.50ID X 2.50

COMMON LRS

# LEGAL REAR STOW FLAIL PIVOT ASSY

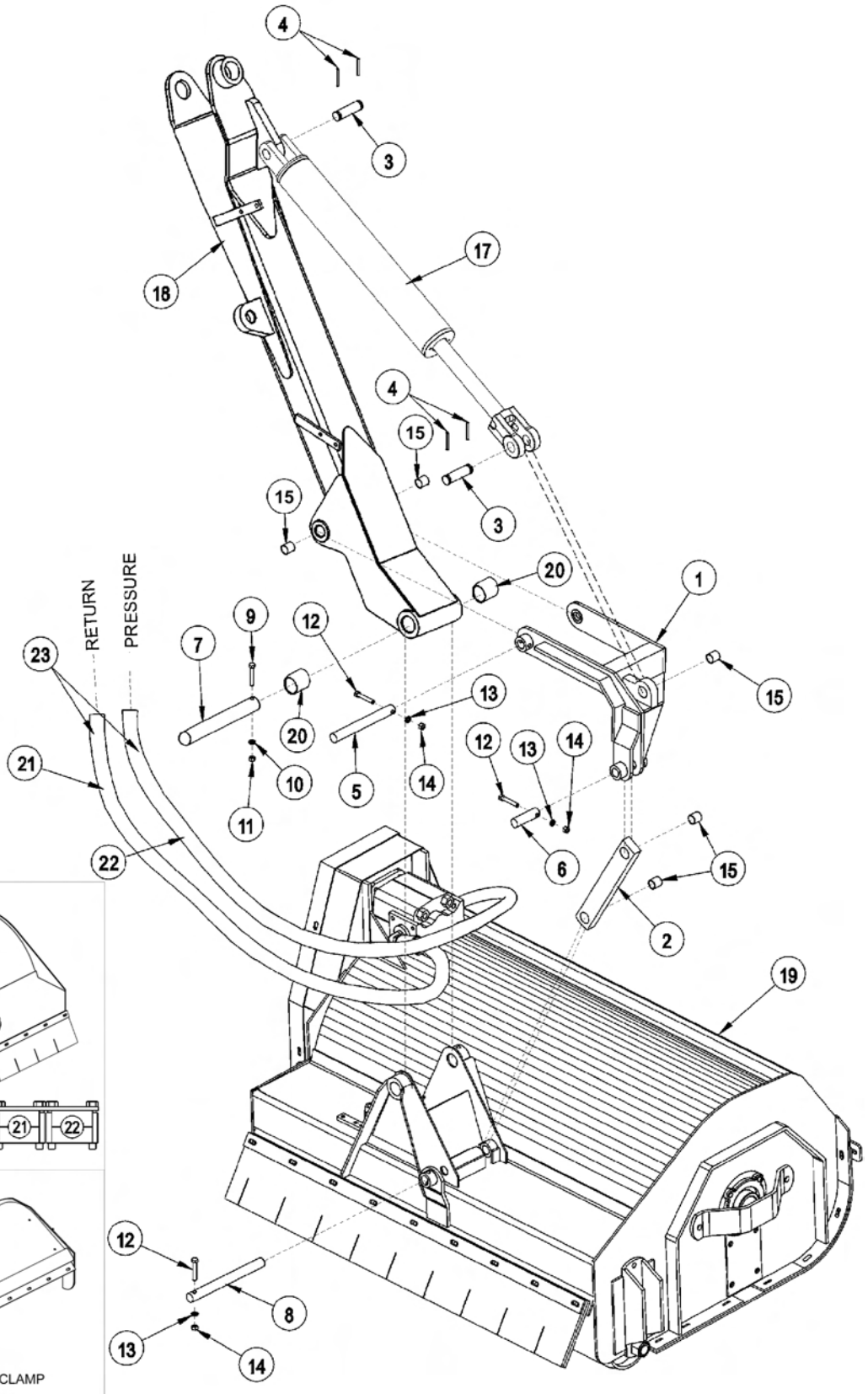

MOTOR SERIAL TAG  
ON TOP

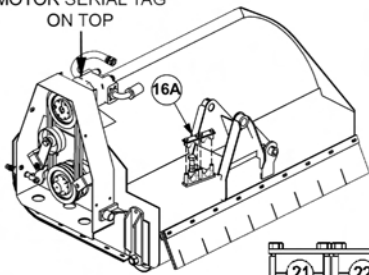

TBF50 HOSE CLAMP

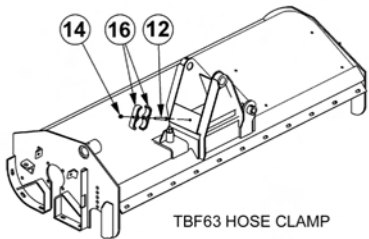

TBF63 HOSE CLAMP

## LEGAL REAR STOW FLAIL PIVOT ASSY

Continued...

ITEM	PART NO.	QTY.	DESCRIPTION
1	06700029	1	PIVOT ASSEMBLY
2	06700015	1	PIVOT ARM ASSEMBLY
3	06420014	2	PIN CLEVIS
4	TB1023	4	ROLL PIN
5	06420019	1	PIN
6	06420020	1	PIN
7	06420018	1	PIN
8	06420021	1	PIN
9	21688	1	CAPSCREW 7/16" X 3 1/4"
10	21989	1	LOCKWASHER 7/16"
11	21675	1	HEX NUT 7/16"
12	21635	2	CAPSCREW 3/8" X 2 1/4"
13	21988	2	LOCKWASHER 3/8"
14	21625	2	HEX NUT 3/8"
15	06520076	5	BEARING, IID X 1
16	TB3031	1	DOUBLE HOSE CLAMP (USED ON THE 63" FLAIL)
16A	31723	1	CLAMP KIT, TBF 50 (USED ON THE 50" FLAIL)
17	-----	-	CYLINDER *REFER TO BOOM ARM ASY
18	-----	-	SECONDARY BOOM *REFER TO BOOM ARM ASY
19	-----	-	FLAIL MOWER HEAD *REFER TO FLAIL CUTTER ASY
20	06520411	2	BEARING, 1.50ID X 2.50
21	06500158	1	HOSE, 1" X 145" (USED ON THE 50" FLAIL)
22	06500159	1	HOSE, 1" X 158" (USED ON THE 50" FLAIL)
23	06500159	2	HOSE, 1" X 158"(USED ON THE 63" FLAIL)

COMMON LRS

# 50IN ROTARY MOWER ASSEMBLY

LINK TO THE SHIELD (OPTIONAL)

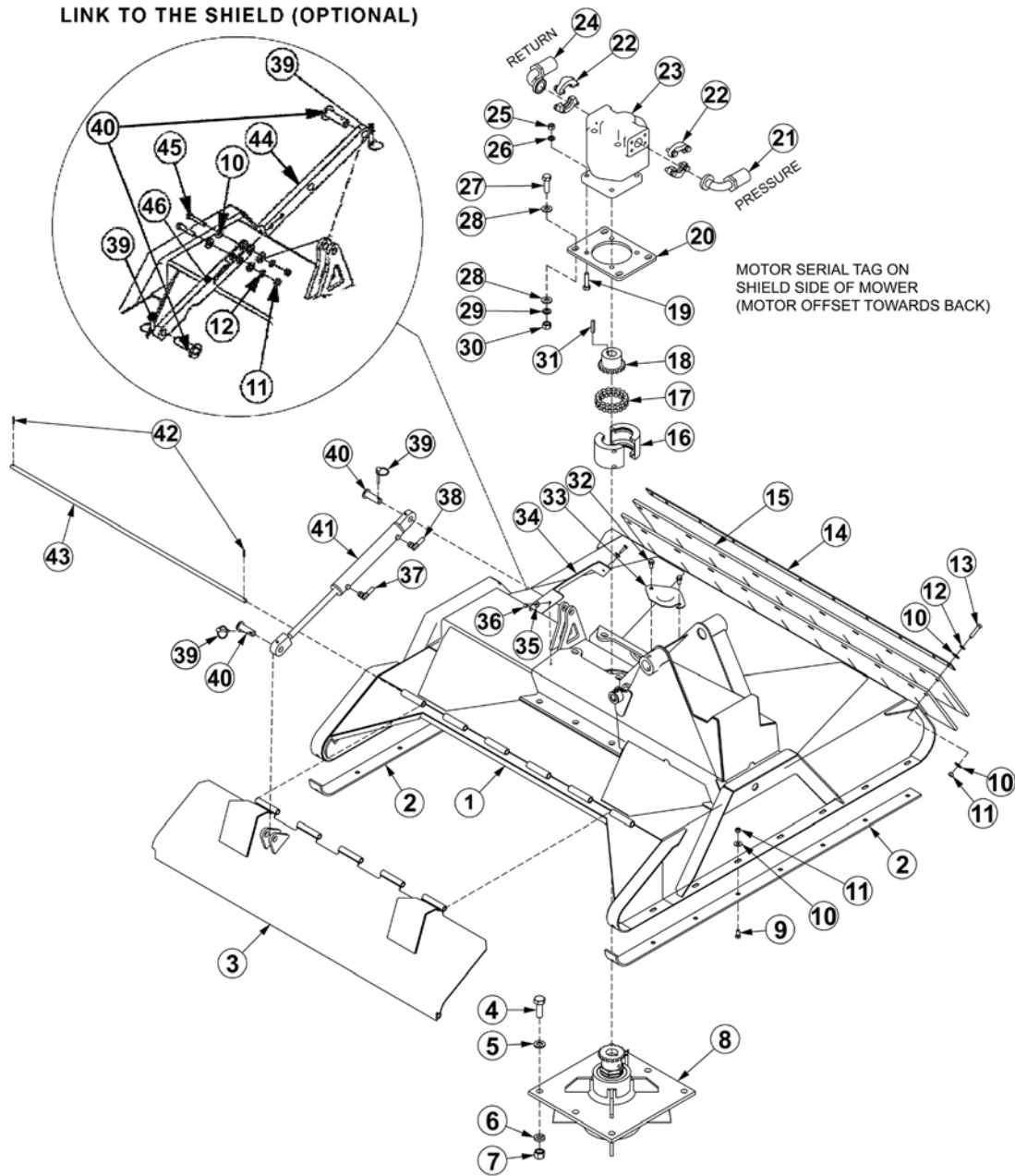

ITEM	PART NO.	QTY.	DESCRIPTION
1	33780	1	DECK,WLDMNT,50" RTRY
2	33777	2	SKID SHOE,50" RTRY
3	33754	1	SHIELD,50"RTRY
4	33879	6	CAPSCREW, 3/4 X 2 1/4,NF GR 8
5	33880	6	FLATWASHER,3/4",GR 8,SAE
6	21993	6	LOCKWASHER,3/4",GR 8
7	6T2413	6	HEX NUT,3/4,NF,GR 8
8	6T1024H5	1	SPINDLE ASSY,CPLT,HD,5/8 HOLES

COMMON LRS

## 50IN ROTARY MOWER ASSEMBLY

**Continued...**

<b>ITEM</b>	<b>PART NO.</b>	<b>QTY.</b>	<b>DESCRIPTION</b>
9	6T2270	16	PLOW BOLT,3/8" X 1" NC
10	22016	33	FLATWASHER,3/8"
11	21625	20	HEX NUT,3/8",NC
12	21988	11	LOCKWASHER, 3/8"
13	21633	11	CAPSCREW, 3/8 X 1 3/4,NC
14	33774	1	FLAP RETAINER,50" RTRY
15	33775	2	FLAP,50" RTRY
16	6T1033	1	COUPLER COVER WITH HARDWARE AND SEALS
17	6T1029	1	COUPLER CHAIN
18	21223	1	SPROCKET
19	21733	4	CAPSCREW, 1/2 X 2,NC
20	33776	1	MOTOR MOUNT,PLATE,50" RTRY
21	24490	1	HOSE - PRESSURE (RED DECAL STRIP)
22	TF4852	2	FLANGE KIT - #20
23	06504012	1	MOTOR (M365-1 3/4" GEAR)
24	24489	1	HOSE - RETURN (BLUE DECAL STRIP)
25	21725	4	HEX NUT, 1/2" NC
26	06533004	4	FLATWASHER, 1/2"
27	6T2290	4	CAPSCREW,5/8X2,NF GR 8
28	33764	8	FLATWASHER,5/8",GR 8,SAE
29	21992	4	LOCKWASHER, 5/8
30	6T2408	4	HEX NUT, 5/8, NF
31	TF1124	1	SQUARE KEY
32	33881	2	CAPSCREW,FLG, 3/8 X 3/4,NC
33	33779	1	PLATE,COVER,KNF HOLE
34	06410439	1	COVER
35	22014	2	FLATWASHER,1/4
36	21530	2	CAPSCREW,1/4 X 1,NC
37	34187	1	HOSE 1/4" X 75"
38	34186	1	HOSE 1/4" X 66"
39	RD1032	2	LYNCH PIN
40	33984	2	PIN,SHIELD,50"
41	33785	1	1-1/2" X 8", CYLINDER, WELDED
42	6T3017	2	ROLLPIN
43	33778	1	HINGE PIN,50" RTRY
44	33772	1	LINK, SHIELD 50" RTRY (OPTIONAL)
45	21634	2	CAPSCREW, 3/8" X 2, NC
46	33773	1	LINK 2, SHIELD 50" RTRY (OPTIONAL)

COMMON LRS

# 60IN ROTARY MOWER ASSEMBLY

LINK TO THE SHIELD (OPTIONAL)

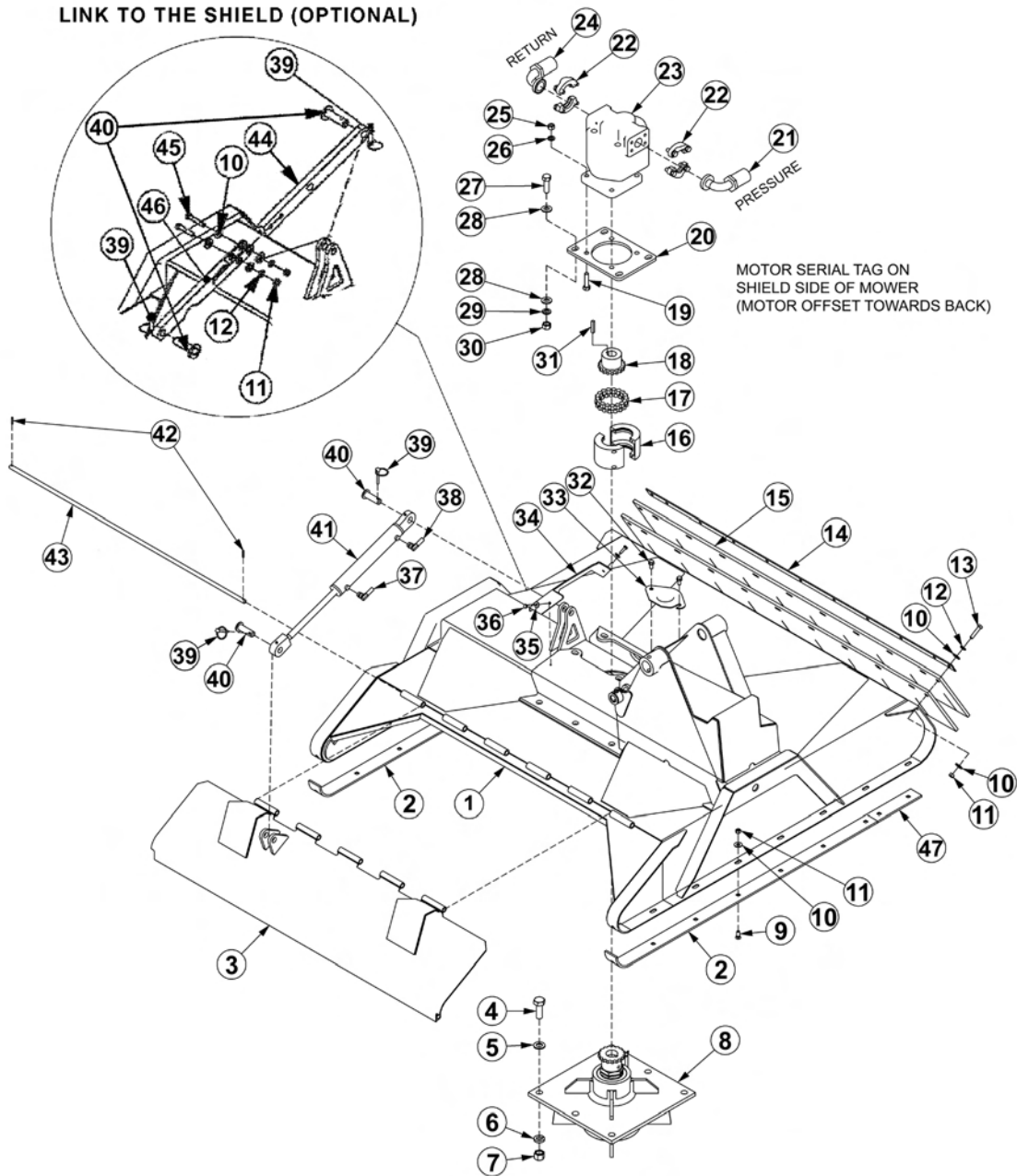

ITEM	PART NO.	QTY.	DESCRIPTION
1	06320159	1	DECK,WLDMNT,60" RTRY
2	33777	2	SKID SHOE,RTRY
3	06320162	1	SHIELD,60"RTRY
4	33879	6	CAPSCREW, 3/4 X 2 1/4,NF GR 8
5	33880	6	FLATWASHER,3/4",GR 8,SAE
6	21993	6	LOCKWASHER,3/4",GR 8
7	6T2413	6	HEX NUT,3/4,NF,GR 8
8	6T1024H5	1	SPINDLE ASSY,CPLT,HD,5/8 HOLES

COMMON LRS

## 60IN ROTARY MOWER ASSEMBLY

**Continued...**

<b>ITEM</b>	<b>PART NO.</b>	<b>QTY.</b>	<b>DESCRIPTION</b>
9	6T2270	16	PLOW BOLT,3/8" X 1" NC
10	22016	33	FLATWASHER,3/8"
11	21625	20	HEX NUT,3/8",NC
12	21988	11	LOCKWASHER, 3/8"
13	21633	11	CAPSCREW, 3/8 X 1 3/4,NC
14	6T0823	1	FLAP RETAINER,60" RTRY
15	06520238	2	FLAP,60" RTRY
16	6T1033	1	COUPLER COVER WITH HARDWARE AND SEALS
17	6T1029	1	COUPLER CHAIN
18	21223	1	SPROCKET
19	21733	4	CAPSCREW, 1/2 X 2,NC
20	33776	1	MOTOR MOUNT,PLATE,RTRY
21	24490	1	HOSE - PRESSURE (RED DECAL STRIP)
22	TF4852	2	FLANGE KIT - #20
23	06504011	1	MOTOR
24	24489	1	HOSE - RETURN (BLUE DECAL STRIP)
25	21725	4	HEX NUT, 1/2" NC
26	06533004	4	FLATWASHER, 1/2"
27	6T2290	4	CAPSCREW,5/8X2,NF GR 8
28	33764	8	FLATWASHER,5/8",GR 8,SAE
29	21992	4	LOCKWASHER, 5/8
30	6T2408	4	HEX NUT, 5/8, NF
31	TF1124	1	SQUARE KEY
32	33881	4	CAPSCREW,FLG, 3/8 X 3/4,NC
33	33779	2	PLATE,COVER,KNF HOLE
34	06410439	1	COVER
35	22014	2	FLATWASHER,1/4
36	21530	2	CAPSCREW,1/4 X 1,NC
37	34187	1	HOSE 1/4" X 75"
38	34186	1	HOSE 1/4" X 66"
39	RD1032	2	LYNCH PIN
40	33984	2	PIN,SHIELD
41	33785	1	1-1/2" X 8", CYLINDER, WELDED
42	6T3017	2	ROLLPIN
43	06420139	1	HINGE PIN,60" RTRY
44	33772	1	LINK, SHIELD,RTRY (OPTIONAL)
45	21634	2	CAPSCREW, 3/8" X 2, NC
46	33773	1	LINK 2, SHIELD,RTRY (OPTIONAL)
47	06401245	2	SKID SHOE,TRB60

COMMON LRS

## 50IN ROTARY KNIVES AND DISH

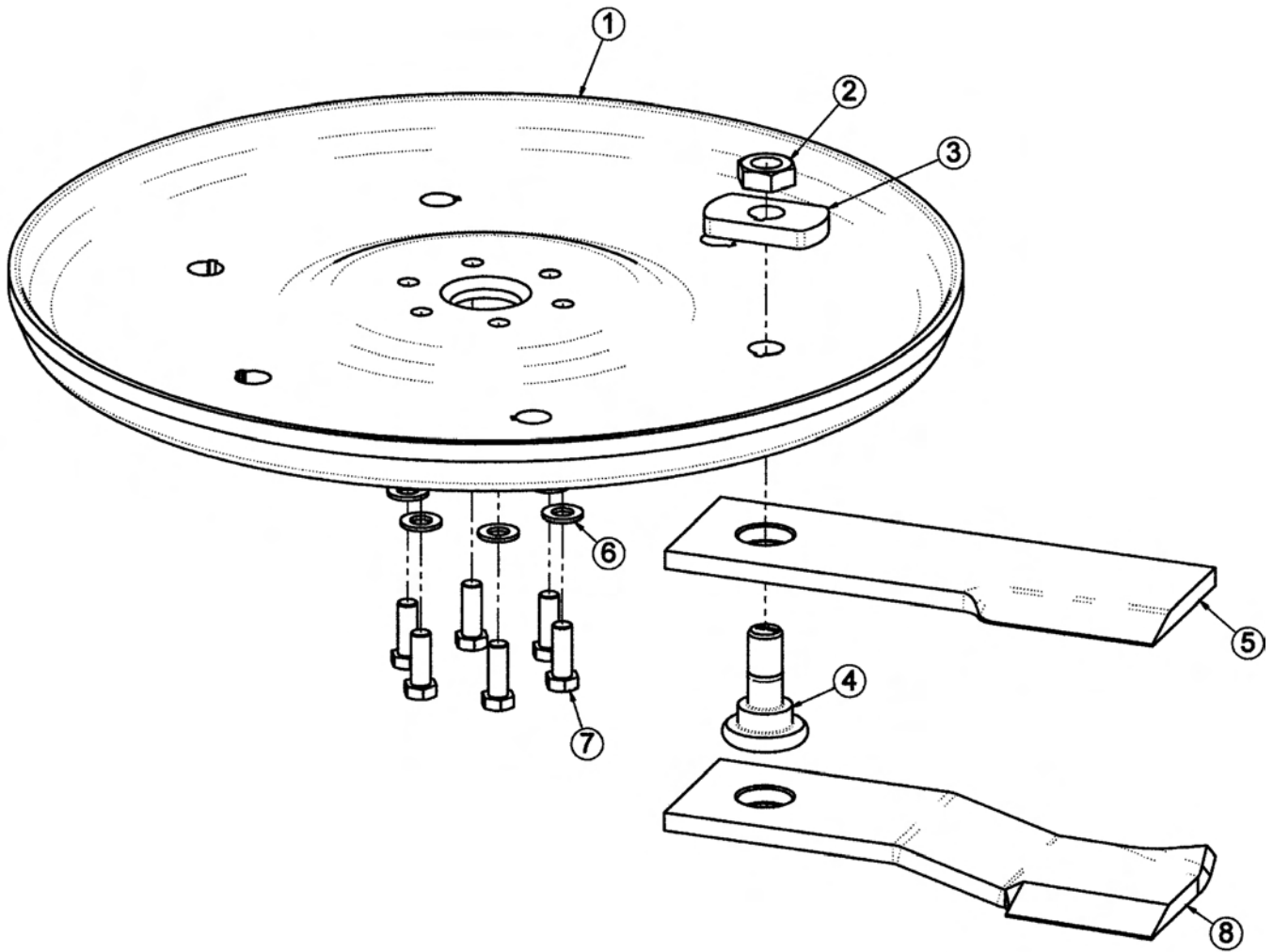

ITEM	PART NO.	QTY.	DESCRIPTION
-----	06700089	-	KIT,TRB50,DISK,W/BOLT KIT (INCLUDES ITEMS 1,3 & 7)
1	06770003	1	BLADE MOUNTING DISK
2	6T1023R	2	NYLOCK HEX NUT 1 1/8"
3	34878	2	SPACER
4	06538000	2	KNIFE MOUNTING BOLT
5	06521001	2	STANDARD KNIFE
6	33764	6	FLATWASHER
7	6T2259	6	CAPSCREW
-----	06770012	-	BOLT KIT (INCLUDES ITEMS 6, 7 & LOCTITE)
8	06521002	2	GRASS KNIFE (OPTIONAL)
-----	6T1825	-	LOCTITE - USED ON ALL DISK MOUNTING BOLTS

COMMON LRS



## 50IN ROTARY BLADE BAR AND KNIVES

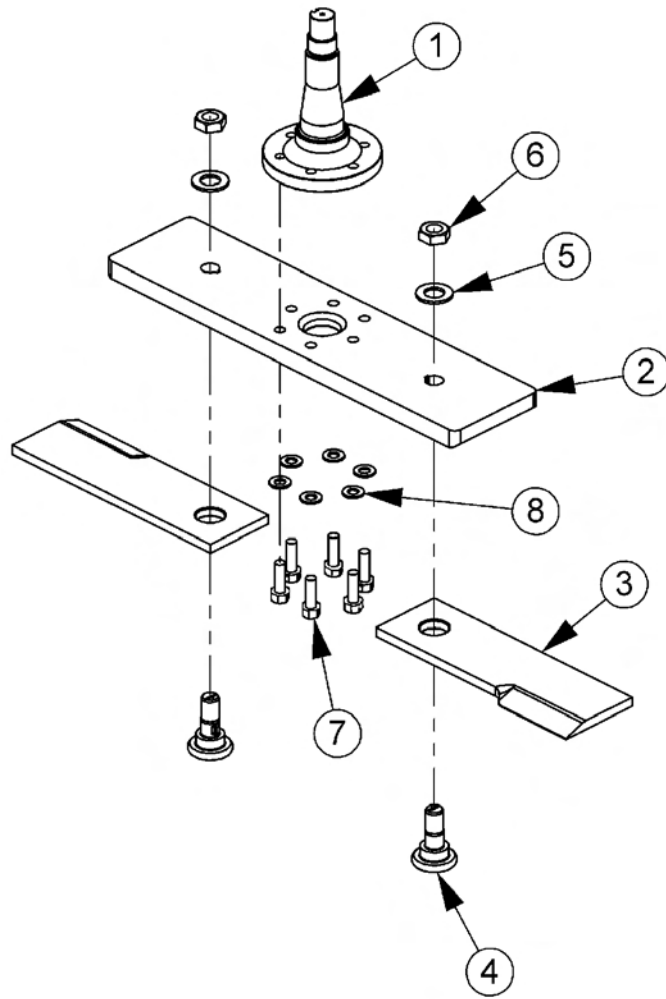

ITEM	PART NO.	QTY.	DESCRIPTION
1	PT1018H5	1	SPINDLE,5/8HOLES,HD,WO/TABS
2	06400388	1	BAR,BLADE,TRB
3	06521001	2	KNIFE,TRB50,5/8
4	06538000	2	KNIFE MTG BOLT,5/8 SHOULDER
5	06533002	2	FLATWASHER,1 1/8,GR 8
6	6T1023R	2	KNIFE MTG NUT,1 1/8,NF,GR8
7	6T2259	6	CAPSCREW,5/8X1-3/4,NF,GR8
8	33764	6	FLATWASHER,5/8,GR 8,SAE

COMMON LRS

## 60IN ROTARY KNIVES AND DISH

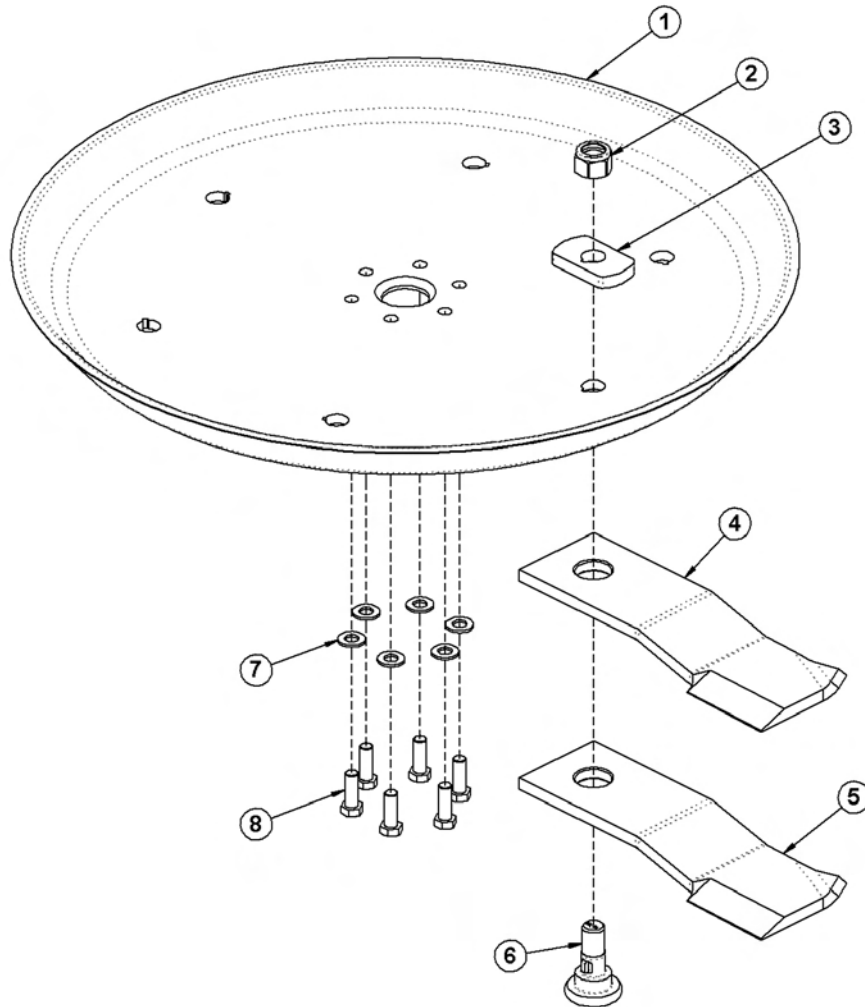

ITEM	PART NO.	QTY.	DESCRIPTION
1	34876	1	BLADE MOUNTING DISH,60"
2	6T1023R	2	NYLOCK NUT,1-1/8",NF
3	34878	2	SPACER
4	34684	2	STANDARD GRASS KNIFE
5	34685	2	HIGH SUCTION GRASS KNIFE (OPTIONAL)
6	34497	2	KNIFE MOUNTING BOLT
7	25270	6	FLATWASHER,5/8",GR8,USS
8	6T2259	6	CAPSCREW,5/8" X 1-3/4",NF,GR8
---	6T1825	1	LOCTITE (USED ON ITEM 8)
---	27167	-	BOLT KIT (INCLUDES ITEMS 7 & 8)
---	33893	-	KNIFE KIT (INCLUDES ITEMS 2, 4 & 6)

COMMON LRS

## 60IN ROTARY BLADE BAR AND KNIVES

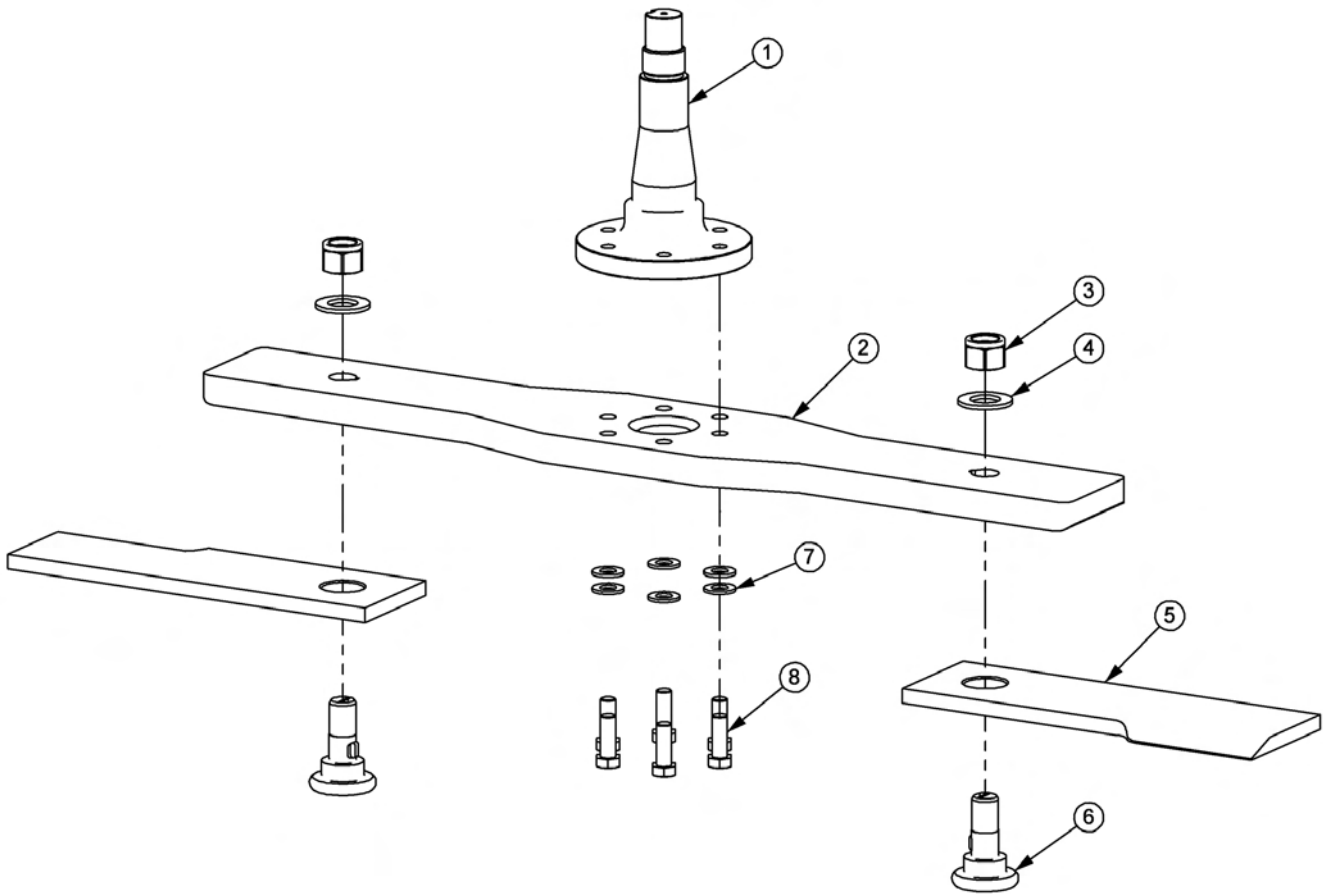

ITEM	PART NO.	QTY.	DESCRIPTION
1	PT1018H5	1	SPINDLE
2	06400690	1	BAR,BLADE,RTRY60
3	6T1023R	2	KNIFE MTG NUT,1-1/8,NYLOCK,NF
4	06533002	2	FLATWASHER,1-1/8,GR8
5	06521001	2	KNIFE,TRB50,5/8
6	06538000	2	KNIFE MTG BOLT,5/8 SHOULDER
7	33764	6	FLATWASHER,5/8,GR 8,SAE
8	6T2259	6	CAPSCREW,5/8 X 1-3/4,NF,GR8

COMMON LRS

50IN FLAIL DRIVE ASSEMBLY

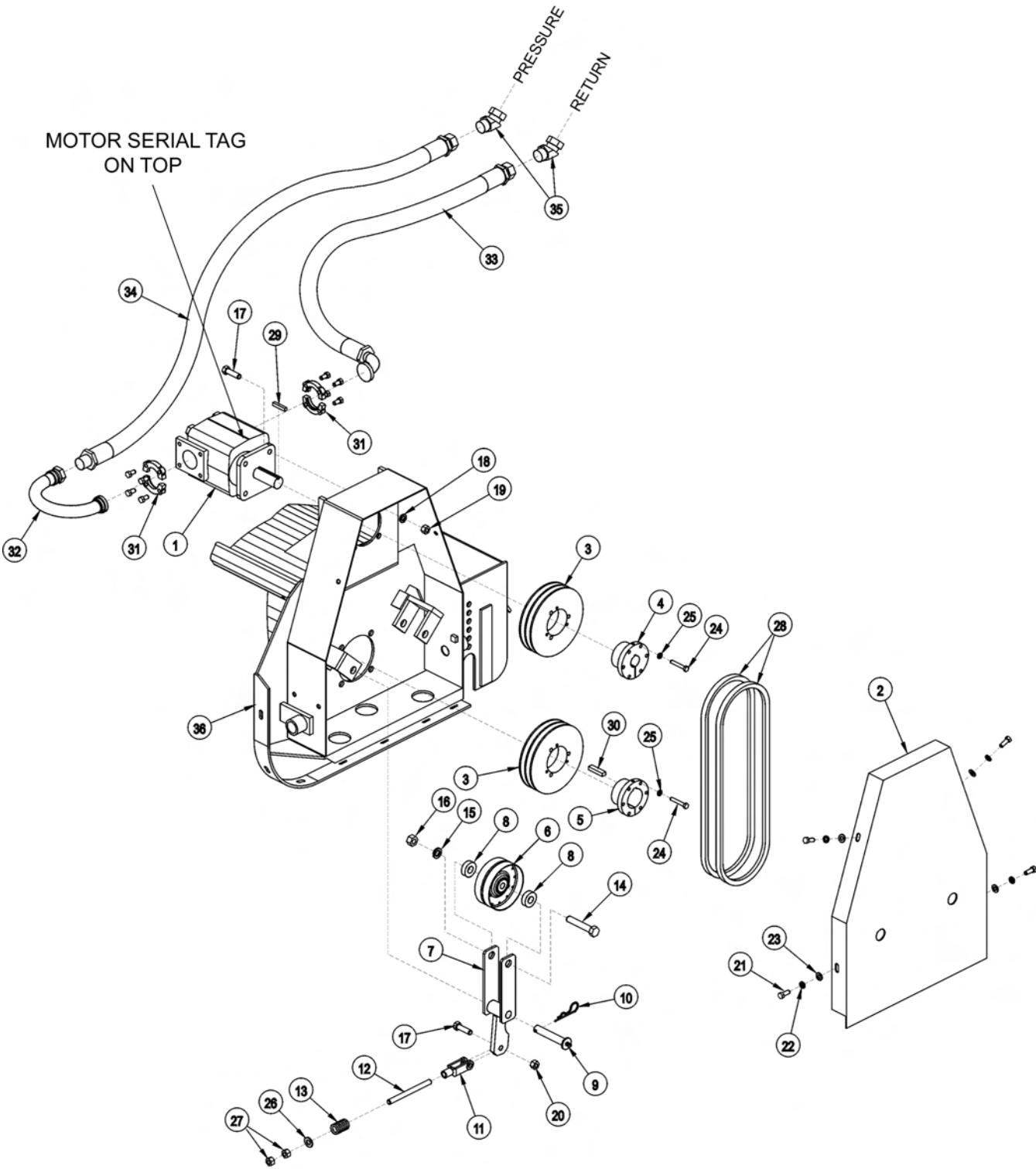

## 50IN FLAIL DRIVE ASSEMBLY

**Continued...**

<b>ITEM</b>	<b>PART NO.</b>	<b>QTY.</b>	<b>DESCRIPTION</b>
1	06504013	1	MOTOR (M350-1 3/4" GEAR)
2	TF3006	1	BELT GUARD
3	TF3043	2	SHEAVE
4	TF3013	1	BUSHING
5	TF3011	1	BUSHING
6	TF3034	1	IDLER PULLEY
7	TF3205	1	IDLER ARM
8	TF3206	2	IDLER PULLEY SPACER
9	TF3605	1	IDLER ARM PIN WITH ZERK
10	6T3004	1	R - CLIP
11	PT3611A	1	CLEVIS
12	32481	1	THREADED ROD
13	TF3620	1	COMPRESSION SPRING
14	21789	1	CAPSCREW 5/8" X 3 1/2"
15	21992	1	LOCKWASHER 5/8"
16	21775	1	HEX NUT 5/8"
17	21732	5	CAPSCREW 1/2" X 1 3/4"
18	21990	4	LOCKWASHER 1/2"
19	21725	4	HEX NUT 1/2"
20	6T2418	1	LOCK NUT 1/2"
21	21630	4	CAPSCREW 3/8" X 1"
22	21988	4	LOCKWASHER 3/8"
23	22016	4	FLATWASHER 3/8"
24	21584	6	CAPSCREW 5/16" X 2"
25	21987	6	LOCKWASHER 5/16"
26	27938	1	FLATWASHER 1/2"
27	21700	2	HEX NUT 1/2" NF
28	TF3021	2	BELT
29	TF1125	1	SQUARE KEY
30	TF1025	1	SQUARE KEY MOTOR
31	TF4852	2	FLANGE KIT
32	31124	1	PREFORMED TUBE
33	31218	1	HOSE - RETURN
34	31219	1	HOSE - PRESSURE
35	24724	2	SWIVEL FITTING
36	-----	-	CUTTER HEAD *REFER TO CUTTER HEAD ASSY

COMMON LRS

# 50IN FLAIL MOWER ASSEMBLY

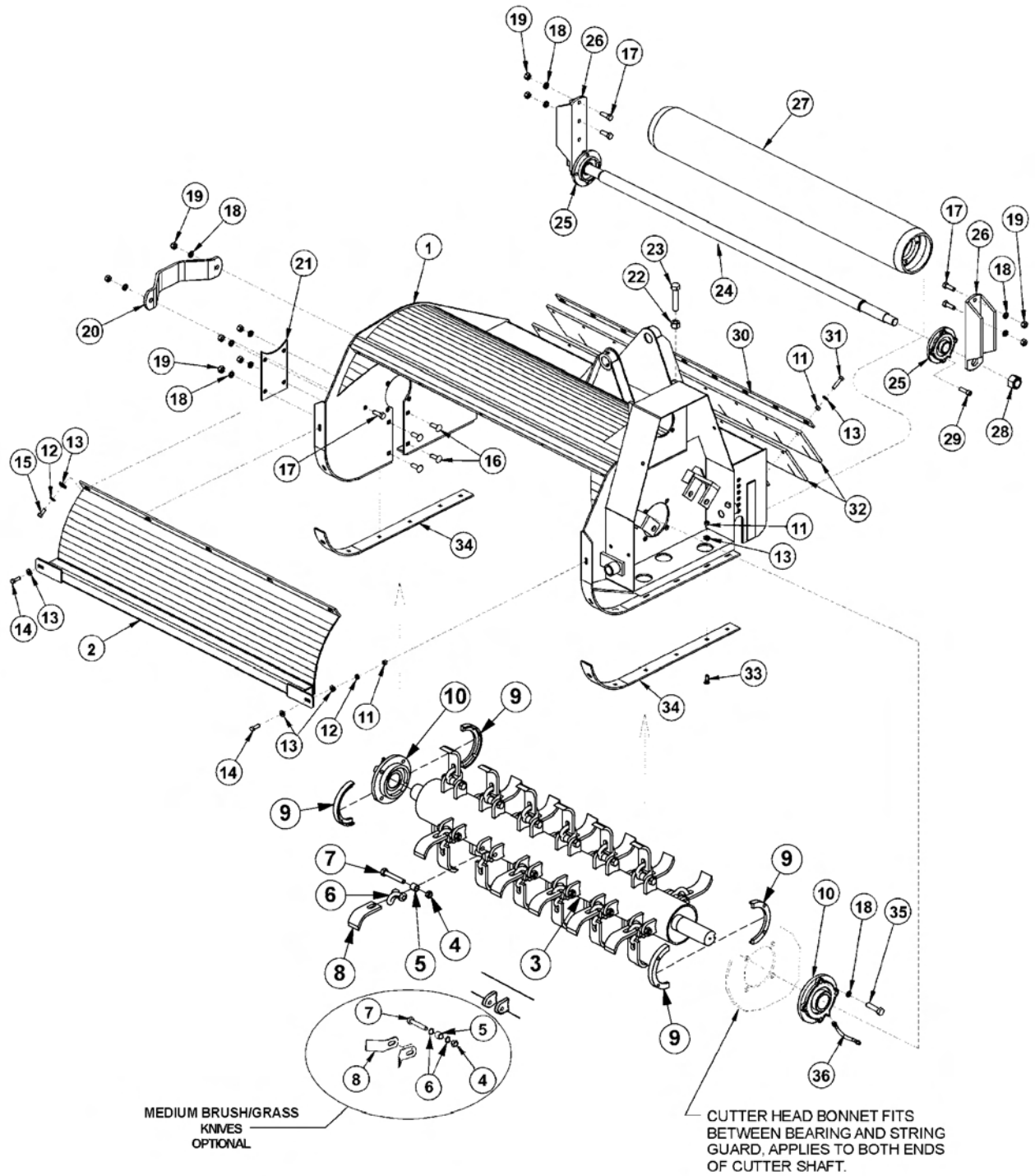

ITEM	PART NO.	QTY.	DESCRIPTION
---	34787	1	FLAIL,BOOM,50,BRUSH,CPLT ASSY (LIGHT BRUSH/GRASS)
	06742133	1	FLAIL,BOOM,50,MD GRASS,CPLT ASSY (MEDIUM BRUSH/GRASS)
1	TF3003F	1	CUTTER HEAD BONNET
2	TF3004	1	FRONT SHIELD

COMMON LRS

## 50IN FLAIL MOWER ASSEMBLY

Continued...

ITEM	PART NO.	QTY.	DESCRIPTION
3	34783	1	TBF50 (LIGHT BRUSH/GRASS KNIFE ASSY)
----	06700115	1	TBF50 (MEDIUM BRUSH/GRASS KNIFE ASSY)
4	6T2419	24	HEX NUT,9/16",NC,STOVER
5	41725.01HT	24	BUSHING,1"OD X 5/8"ID
6	34782	24	CLEVIS (LIGHT BRUSH/GRASS KNIVES)
----	06430122	48	SPACER (MEDIUM BRUSH/GRASS KNIVES)
7	34786	24	CAPSCREW,9/16" X 3-1/2",NC
8	34780	24	KNIFE (LIGHT BRUSH/GRASS CUTTING)
----	06521007	48	KNIFE (MEDIUM BRUSH/GRASS CUTTING)
9	31204	2	STRING GUARD SET (2 PIECES PER SET)
10	TF1018	2	FLANGE BEARING,2-3/16"
11	21625	23	HEX NUT,3/8",NC
12	21988	7	LOCKWASHER,3/8"
13	22016	30	FLATWASHER,3/8"
14	21631	2	CAPSCREW,3/8" X 1-1/4",NC
15	21630	5	CAPSCREW,3/8" X 1",NC
16	6T7031D	4	PLOW BOLT,1/2" X 1-1/2",NC
17	21731	6	CAPSCREW,1/2" X 1-1/2",NC
18	21990	18	LOCKWASHER,1/2"
19	21725	10	HEX NUT,1/2",NC
20	TF1040	1	CUTTER SHAFT GUARD
21	TF3007A	1	COVER PLATE
22	21825	1	HEX NUT,5/8",NC
23	21838	1	CAPSCREW,3/4" X 3-1/2",NC
24	TF3406	1	GROUND ROLLER TIE ROD
25	TF1022	2	FLANGE BEARING,1-3/8"
26	TF3407	2	GROUND ROLLER ADJUSTMENT BRACKET
27	TF3405	1	GROUND ROLLER
28	6T1023R	2	NYLOCK NUT,1-1/8",NF
29	6T2330	8	CAPSCREW,7/16" X 1-1/2",SOCKET HEAD
30	TB1008	1	FLAP RETAINING BAR
31	21633	9	CAPSCREW,3/8" X 1-3/4",NC
32	TB1006A	2	DEFLECTOR FLAP
33	6T2270	12	PLOWBOLT,3/8" X 1",NC
34	TF3001	2	SKID SHOE
35	06530218	8	CAPSCREW,1/2" X 1-3/4",NC
36	TF1032	1	FLANGE BEARING GREASE HOSE

COMMON LRS

# 50IN FLAIL MOWER ASSY, PASS-THROUGH KNIVES

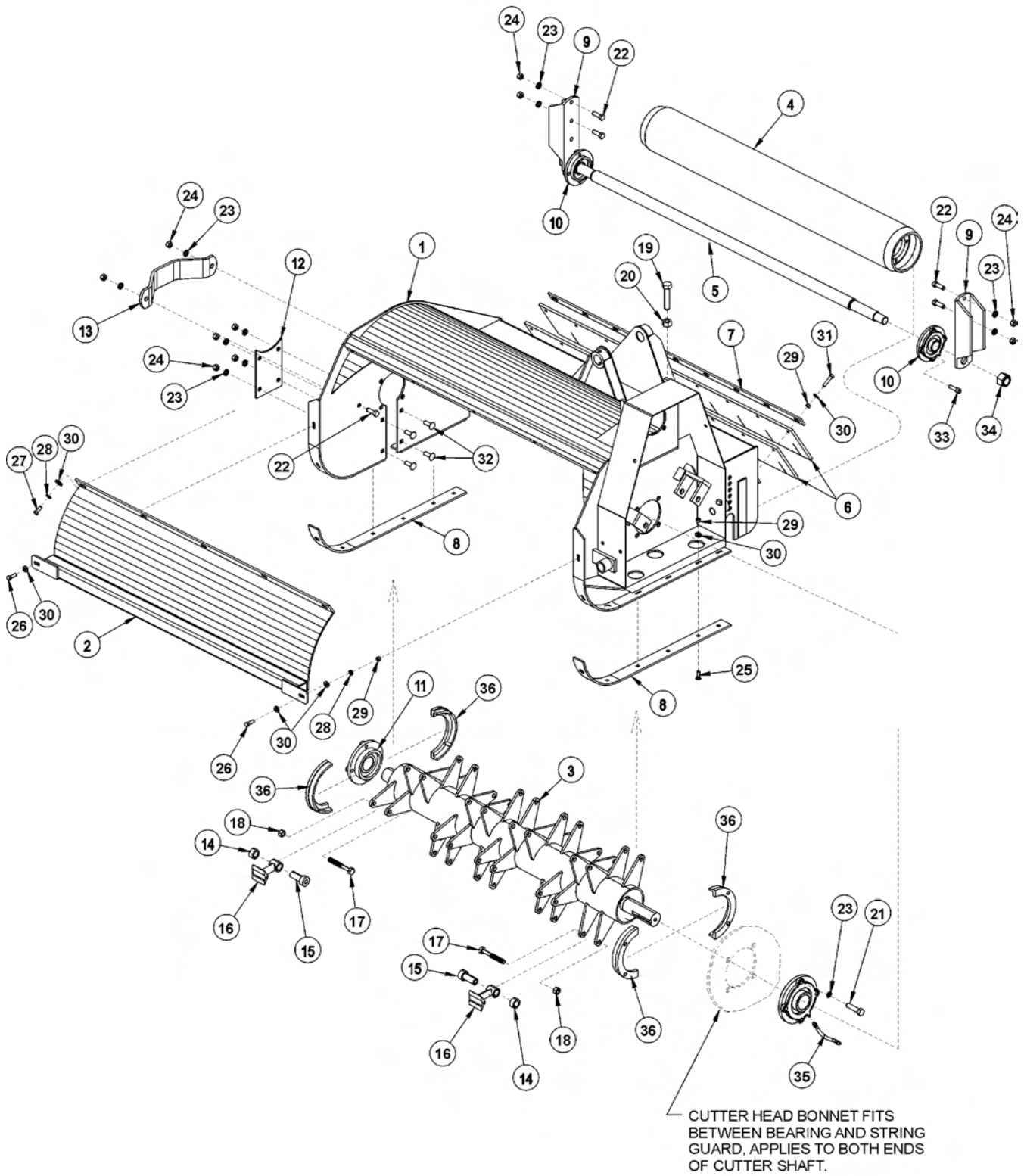



## 50IN FLAIL MOWER ASSY, PASS-THROUGH KNIVES

Continued...

ITEM	PART NO.	QTY.	DESCRIPTION
---	34172	1	FLAIL,BOOM,50,CPLT ASSY
1	TF3003F	1	CUTTER HEAD BONNET
2	TF3004	1	FRONT SHIELD
3	33717	1	TBF50,CUTTERSHAFT,PASS THRU KNIVES
4	TF3405	1	GROUND ROLLER
5	TF3406	1	GROUND ROLLER TIE ROD
6	TB1006A	2	DEFLECTOR FLAP
7	TB1008	1	FLAP RETAINING BAR
8	TF3001	2	SKID SHOE
9	TF3407	2	GROUND ROLLER ADJUSTMENT BRACKET
10	TF1022	2	FLANGE BEARING,1-3/8"
11	TF1018	2	FLANGE BEARING,2-3/16"
12	TF3007A	1	COVER PLATE
13	TF1040	1	CUTTER SHAFT GUARD
14	33858	24	SPACER,COLLAR
15	33857	24	SHOULDER,BUSHING
16	46399.01	24	KNIFE,FLAIL,FORGED
17	33854	24	CAPSCREW,5/8" X 4-1/2",NC
18	32674	24	HEX NUT,5/8",NC
19	21838	1	CAPSCREW,3/4" X 3-1/2",NC
20	21825	1	HEX NUT,5/8",NC
21	21732	8	CAPSCREW,1/2" X 1-3/4",NC
22	21731	6	CAPSCREW,1/2" X 1-1/2",NC
23	21990	18	LOCKWASHER,1/2"
24	21725	10	HEX NUT,1/2",NC
25	6T2270	12	PLOWBOLT,3/8" X 1",NC
26	21631	2	CAPSCREW,3/8" X 1-1/4",NC
27	21630	5	CAPSCREW,3/8" X 1",NC
28	21988	7	LOCKWASHER,3/8"
29	21625	23	HEX NUT,3/8",NC
30	22016	30	FLATWASHER,3/8"
31	21633	9	CAPSCREW,3/8" X 1-3/4",NC
32	6T7031D	4	PLOW BOLT,1/2" X 1-1/2",NC
33	6T2330	8	CAPSCREW,7/16" X 1-1/2",NC,SCKT HD
34	6T1023R	2	NYLOCK NUT,1-1/8",NF
35	TF1032	1	FLANGE BEARING GREASE HOSE
36	31204	2	STRING GUARD SET (2 PIECES PER SET)

COMMON LRS

# 63IN FLAIL DRIVE ASSEMBLY

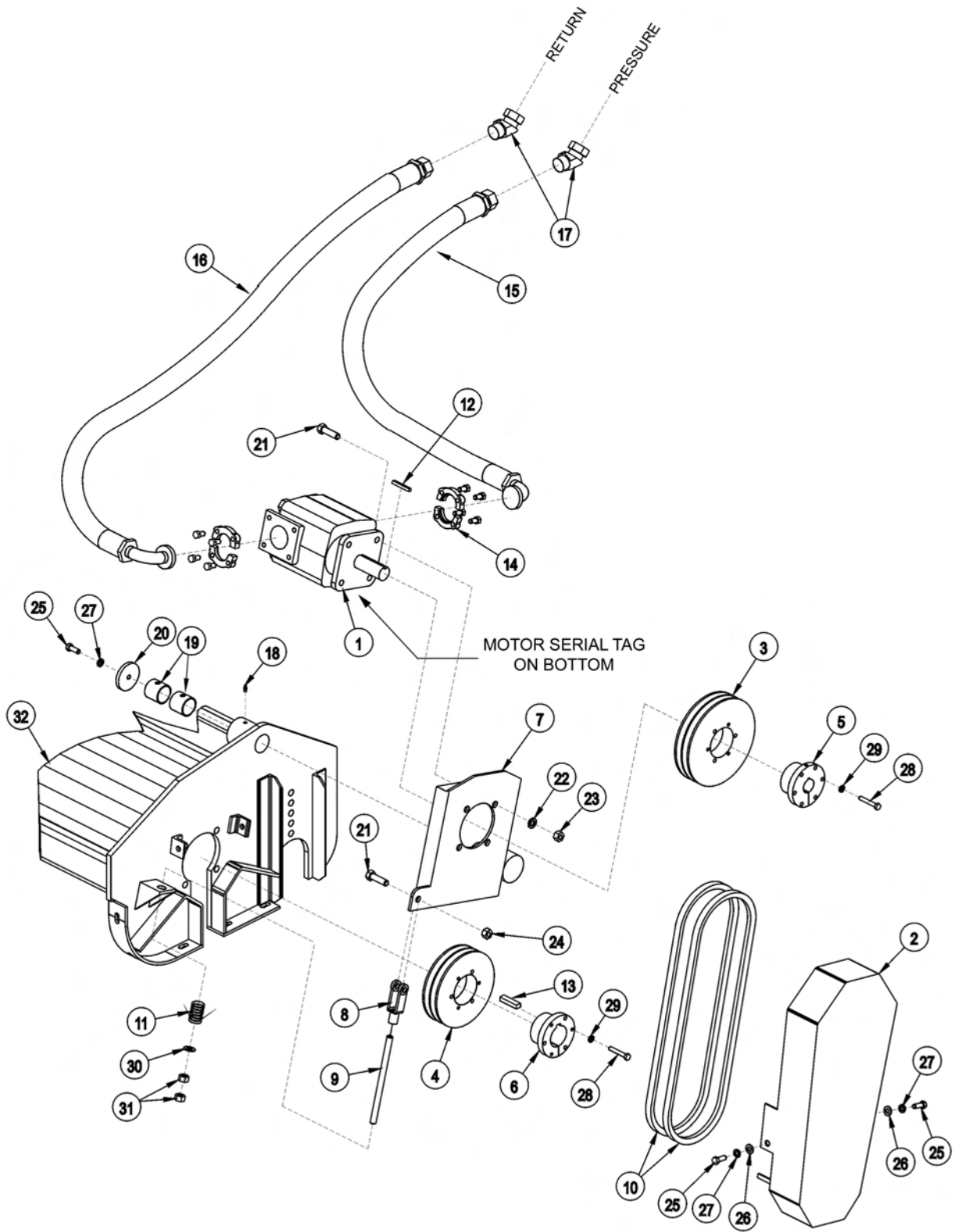

## 63IN FLAIL DRIVE ASSEMBLY

Continued...

ITEM	PART NO.	QTY.	DESCRIPTION
1	06504013	1	MOTOR (M350-1 3/4 GEAR)
2	32569	1	BELT GUARD
3	TF3044	1	UPPER SHEAVE
4	TF3040	1	LOWER SHEAVE
5	TF3013	1	BUSHING
6	28723	1	BUSHING
7	28679B	1	MOTOR CHANNEL
8	PT3611A	1	CLEVIS
9	40496	1	THREADED ROD
10	28702	2	BELT
11	TF3620A	1	TENSIONER SPRING
12	28572	1	SQUARE KEY
13	26142A	1	SQUARE KEY
14	TF4852	2	FLANGE KIT
15	30308	1	HOSE,1 X 69 - PRESSURE
16	30309	1	HOSE,1 X 78 - RETURN
17	24724	2	SWIVEL FITTING
18	TF1033	1	GREASE ZERK
19	27580	2	BUSHING
20	28682	1	MOTOR CHANNEL WASHER
21	21732	5	CAPSCREW 1/2" X 1 3/4"
22	21990	4	LOCKWASHER 1/2"
23	21725	4	HEX NUT 1/2"
24	6T2418	1	STOVER NUT 1/2"
25	21630	3	CAPSCREW 3/8" X 1"
26	22016	2	FLATWASHER 3/8"
27	21988	3	LOCKWASHER 3/8"
28	21584	6	CAPSCREW 5/16" X 2"
29	21987	6	LOCKWASHER 5/16"
30	27938	1	FLATWASHER 1/2"
31	21700	2	HEX NUT 1/2" NF
32	-----	-	CUTTER HEAD *REFER TO MOWER ASSY

COMMON LRS

# 63IN FLAIL MOWER ASSEMBLY

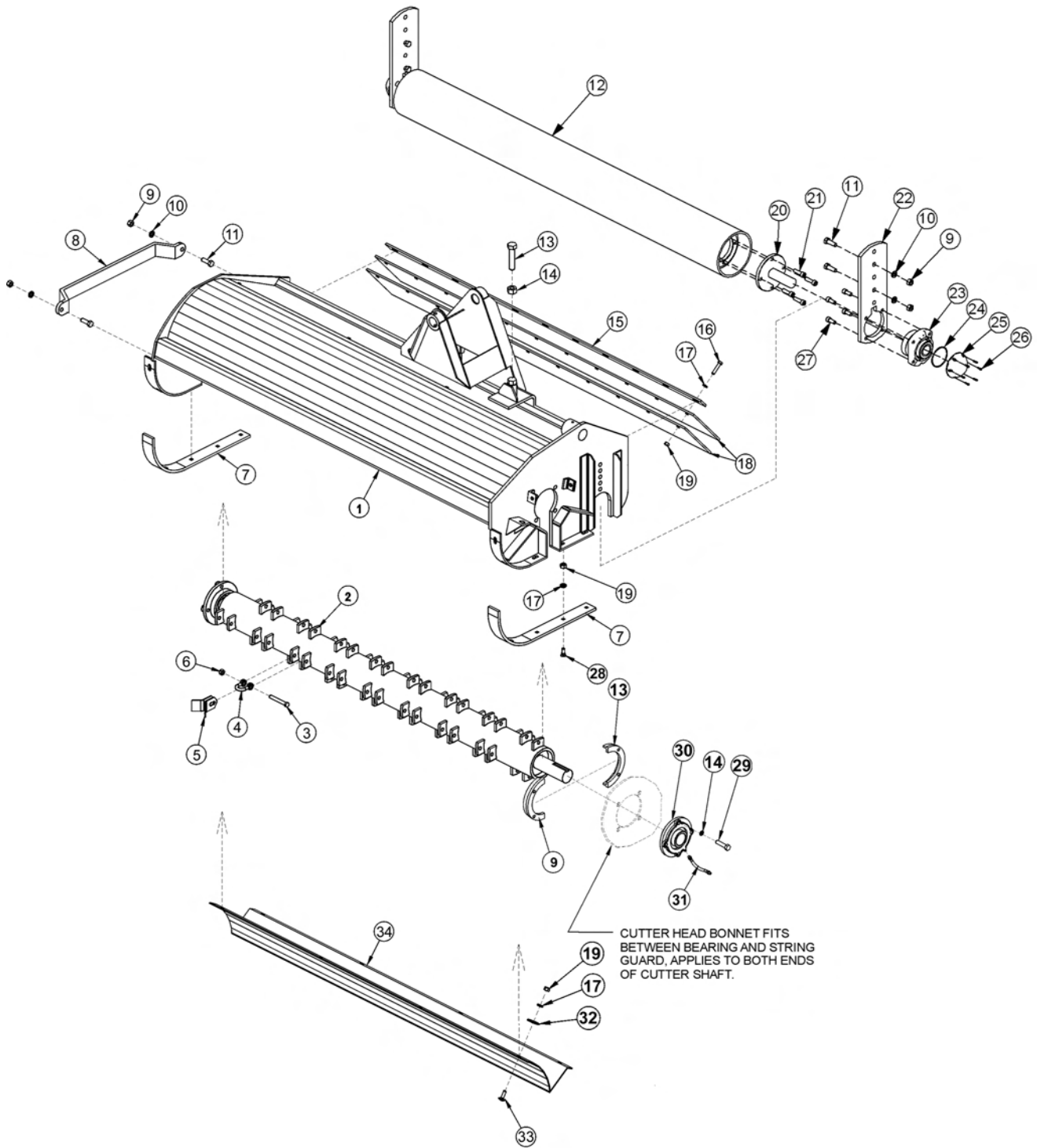

## 63IN FLAIL MOWER ASSEMBLY

Continued...

ITEM	PART NO.	QTY.	DESCRIPTION
-----	06200271	-	FLAIL,BOOM,63,GRASS,CPLT ASSY
1	28659H	1	CUTTER HEAD BONNET
2	28743	-	CUTTER SHAFT / KNIFE ASSY STANDARD GRASS
-----	28642C	1	CUTTER SHAFT,63,STD
3	34011	36	FLAIL KNIFE MOUNTING BOLT
4	TF1020	36	FLAIL KNIFE MOUNTING CLEVIS
5	33713	72	FLAIL KNIFE - STANDARD
6	21677	36	NYLOCK NUT
7	28086A	2	SKID SHOE
8	27975A	1	CUTTER SHAFT GUARD
9	21725	14	HEX NUT 1/2"
10	21990	14	LOCKWASHER 1/2"
11	21731	6	CAPSCREW 1/2" X 1 1/2"
12	28650A	1	GROUND ROLLER
13	33863	2	STRING GUARD,STD
14	06533006	8	FLATWASHER,1/2",SAE,L9
15	28700	1	FLAP RETAINING BAR
16	21633	11	CAPSCREW 3/8" X 1 3/4"
17	21988	28	LOCKWASHER 3/8"
18	28701	2	DEFLECTOR FLAP
19	21625	28	HEX NUT 3/8"
20	TF1045B	2	GROUND ROLLER STUB SHAFT
21	6T2330	8	CAPSCREW 7/16" X 1 1/2" SOCKET HEAD
22	28735	2	ADJUSTABLE ROLLER BRACKET
23	06520028	2	BEARING,FLANGE,1-3/8,GRNDRLLR
24	06520029	2	O-RING
25	06520027	2	CAP,BEARING,GROUNDROLLER
26	06530001	12	CAPSCREW,SKT HD,8-32 X 1/2,SS
27	6T2331	8	CAPSCREW 7/16" X 1" SOCKET HEAD
28	6T2270	10	PLOW BOLT 3/8" X 1 1/4"
29	06530217	8	CAPSCREW 1/2" X 2",L9
30	28683	2	FLANGE BEARING
31	TF1032	1	FLANGE BEARING GREASE HOSE
32	6T2615	7	FENDER WASHER 3/8"
33	6T2283	7	CARRIAGE BOLT 3/8" X 1"
34	28665A	1	BAFFLE (INSIDE UPPER REAR OF CUTTER HEAD)

COMMON LRS

## 3IN X 10IN WELDED CYLINDER BREAKDOWN

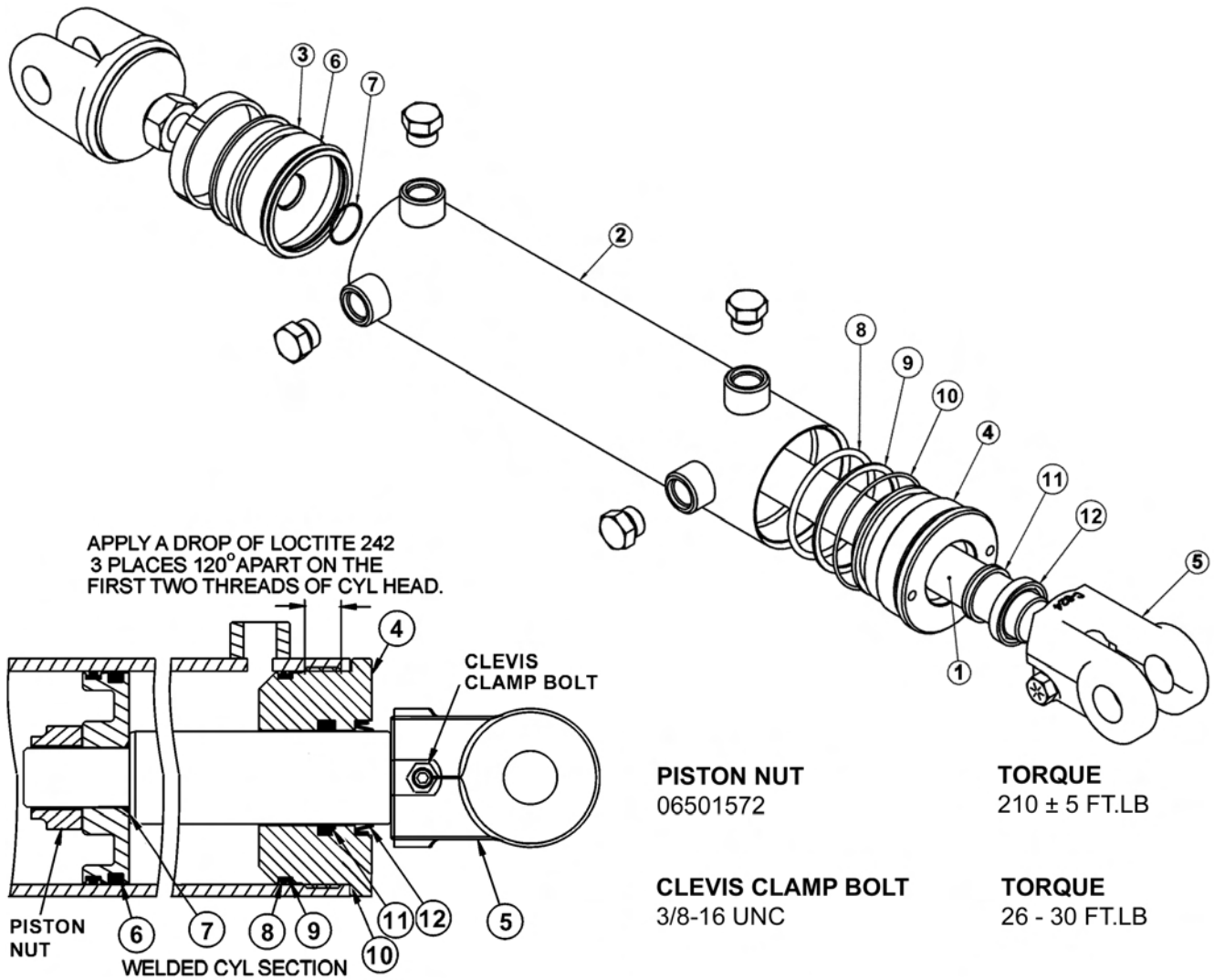

**WARNING - MECHANICAL FASTENERS MUST BE TORQUED TO RECOMMENDED SPECIFICATIONS DURING REPAIR TO PREVENT PERSONAL INJURY OR EQUIPMENT DAMAGE.**

ITEM	PART NO.	QTY.	DESCRIPTION
-----	06501021	-	HYDRAULIC CYLINDER COMPLETE
1	06501550	1	ROD
2	06501551	1	TUBE WELDMENT
3	06501552	1	PISTON
4	06501553	1	CYLINDER HEAD
5	06501554	1	CLEVIS
-----	06501555	-	SEAL REPAIR KIT (ITEMS 6 THROUGH 12)

## 3IN X 18IN WELDED CYLINDER BREAKDOWN

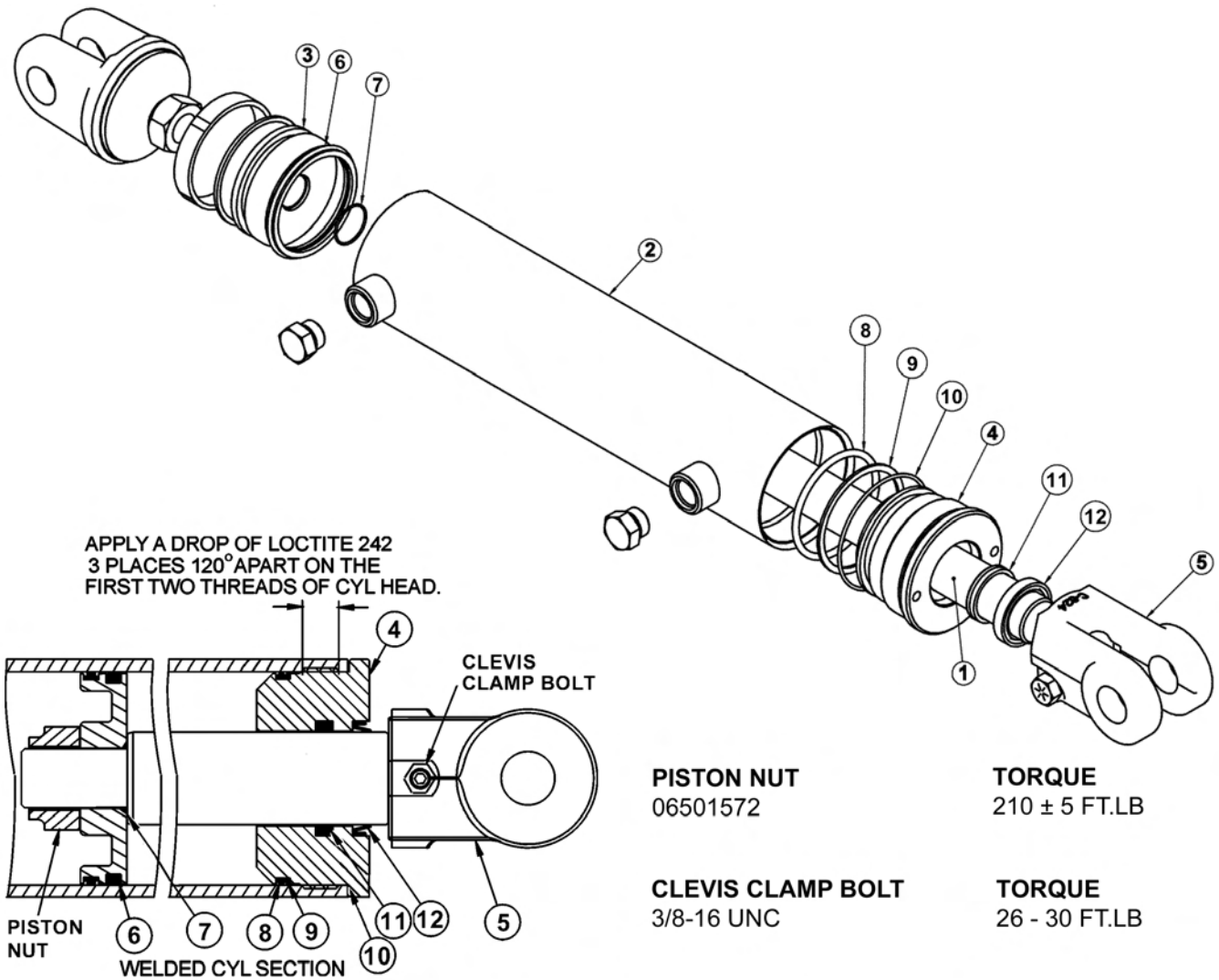

**WARNING - MECHANICAL FASTENERS MUST BE TORQUED TO RECOMMENDED SPECIFICATIONS DURING REPAIR TO PREVENT PERSONAL INJURY OR EQUIPMENT DAMAGE.**

ITEM	PART NO.	QTY.	DESCRIPTION
-----	06501023	-	HYDRAULIC CYLINDER COMPLETE
1	06501561	1	ROD
2	06501562	1	TUBE WELDMENT
3	06501552	1	PISTON
4	06501563	1	CYLINDER HEAD
5	06501554	1	CLEVIS
-----	06501564	-	SEAL REPAIR KIT (ITEMS 6 THROUGH 12)

## 3-1/2IN X 20IN WELDED CYLINDER BREAKDOWN

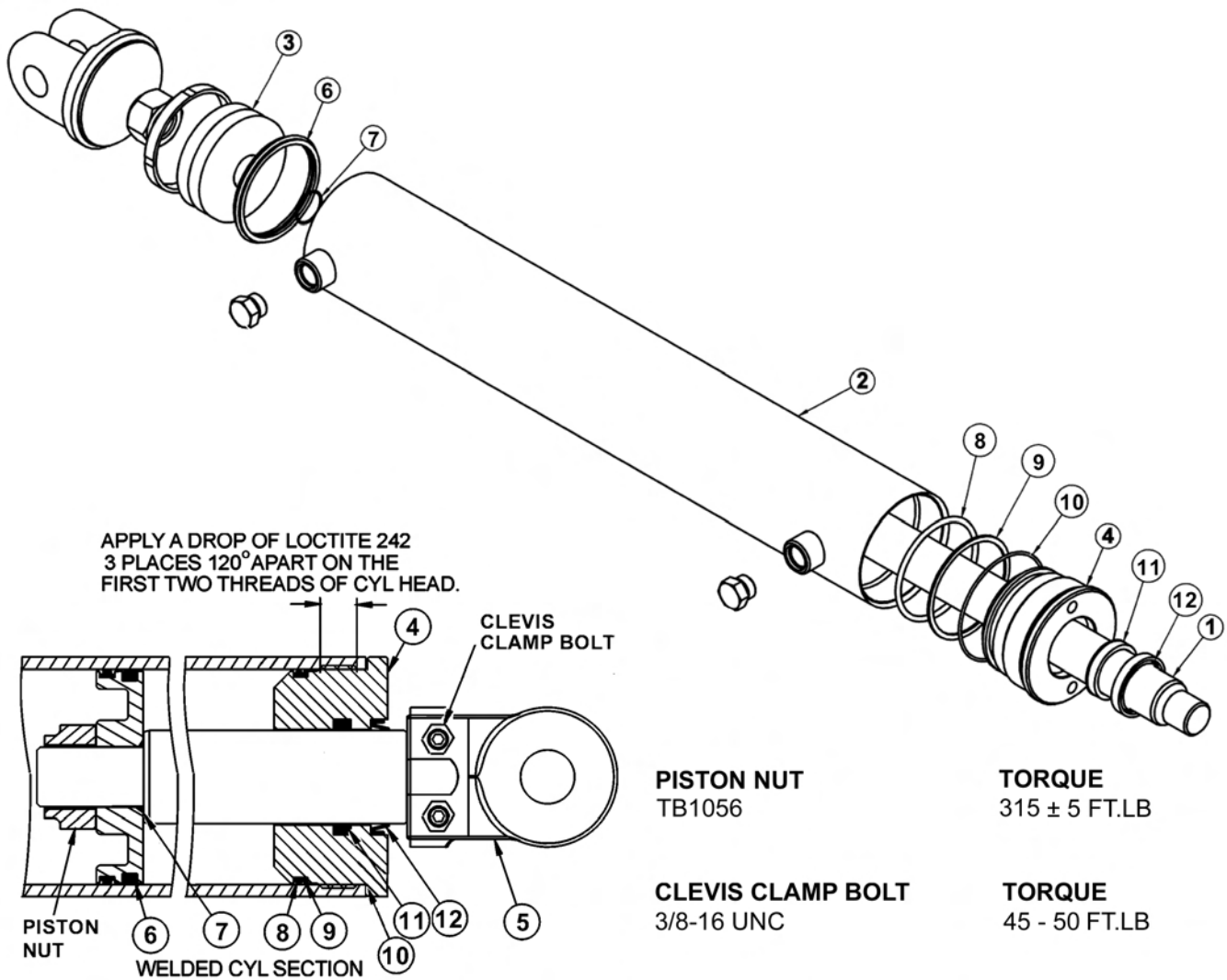

**WARNING - MECHANICAL FASTENERS MUST BE TORQUED TO RECOMMENDED SPECIFICATIONS DURING REPAIR TO PREVENT PERSONAL INJURY OR EQUIPMENT DAMAGE.**

ITEM	PART NO.	QTY.	DESCRIPTION
-----	06501024	-	HYDRAULIC CYLINDER COMPLETE
1	06501565	1	ROD
2	06501566	1	TUBE WELDMENT
3	06501567	1	PISTON
4	06501568	1	CYLINDER HEAD
5	TB3033	-	CLEVIS
-----	06501569	-	SEAL REPAIR KIT (ITEMS 6 THROUGH 12)



## 4IN X 9IN WELDED CYLINDER BREAKDOWN

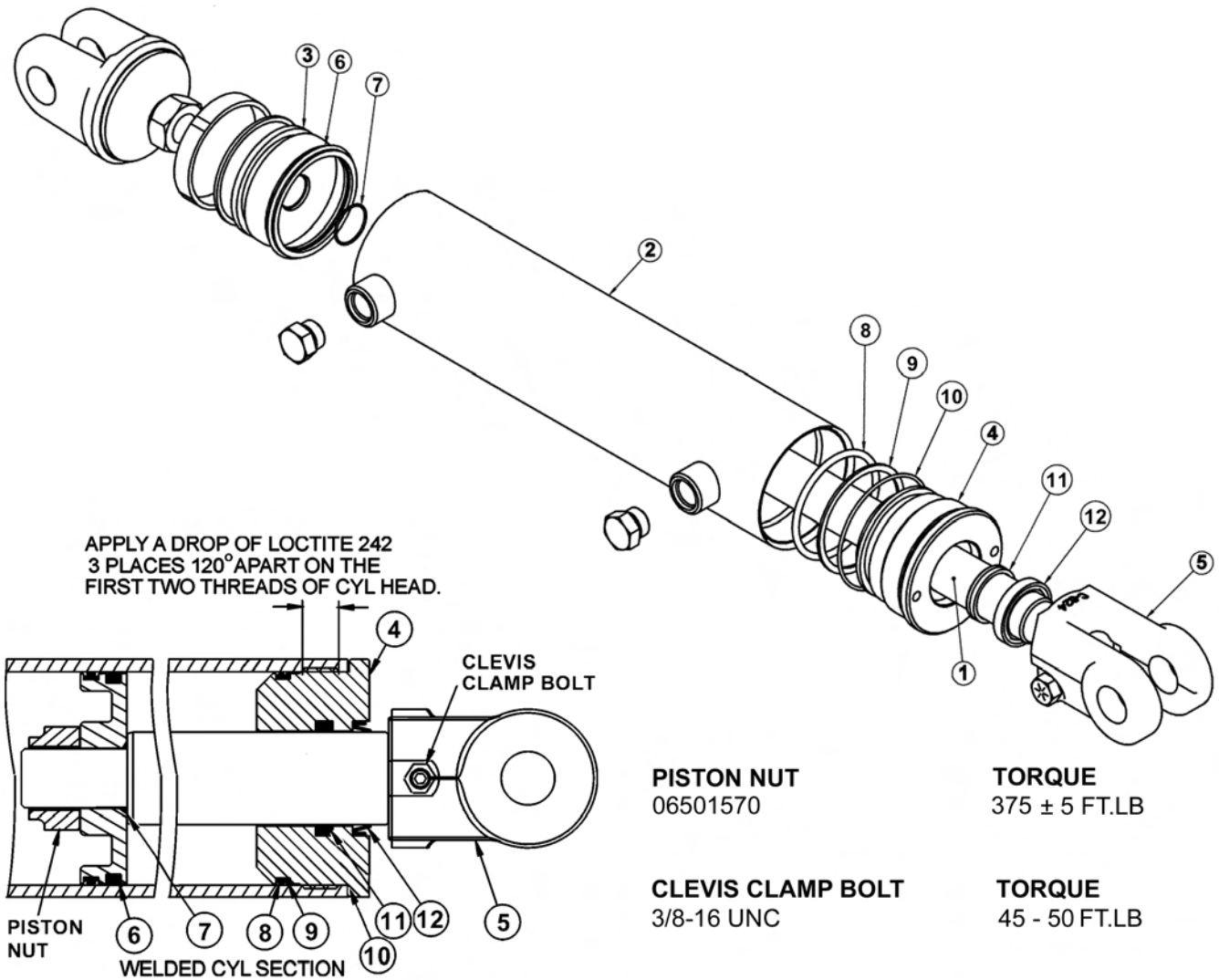

**WARNING - MECHANICAL FASTENERS MUST BE TORQUED TO RECOMMENDED SPECIFICATIONS DURING REPAIR TO PREVENT PERSONAL INJURY OR EQUIPMENT DAMAGE.**

ITEM	PART NO.	QTY.	DESCRIPTION
-----	06501019	-	HYDRAULIC CYLINDER COMPLETE
1	06501538	1	ROD
2	06501539	1	TUBE WELDMENT
3	06501540	1	PISTON
4	06501541	1	CYLINDER HEAD
5	06501542	1	CLEVIS
-----	06501543	-	SEAL REPAIR KIT (ITEMS 6 THROUGH 12)

## 4IN X 20IN WELDED CYLINDER BREAKDOWN

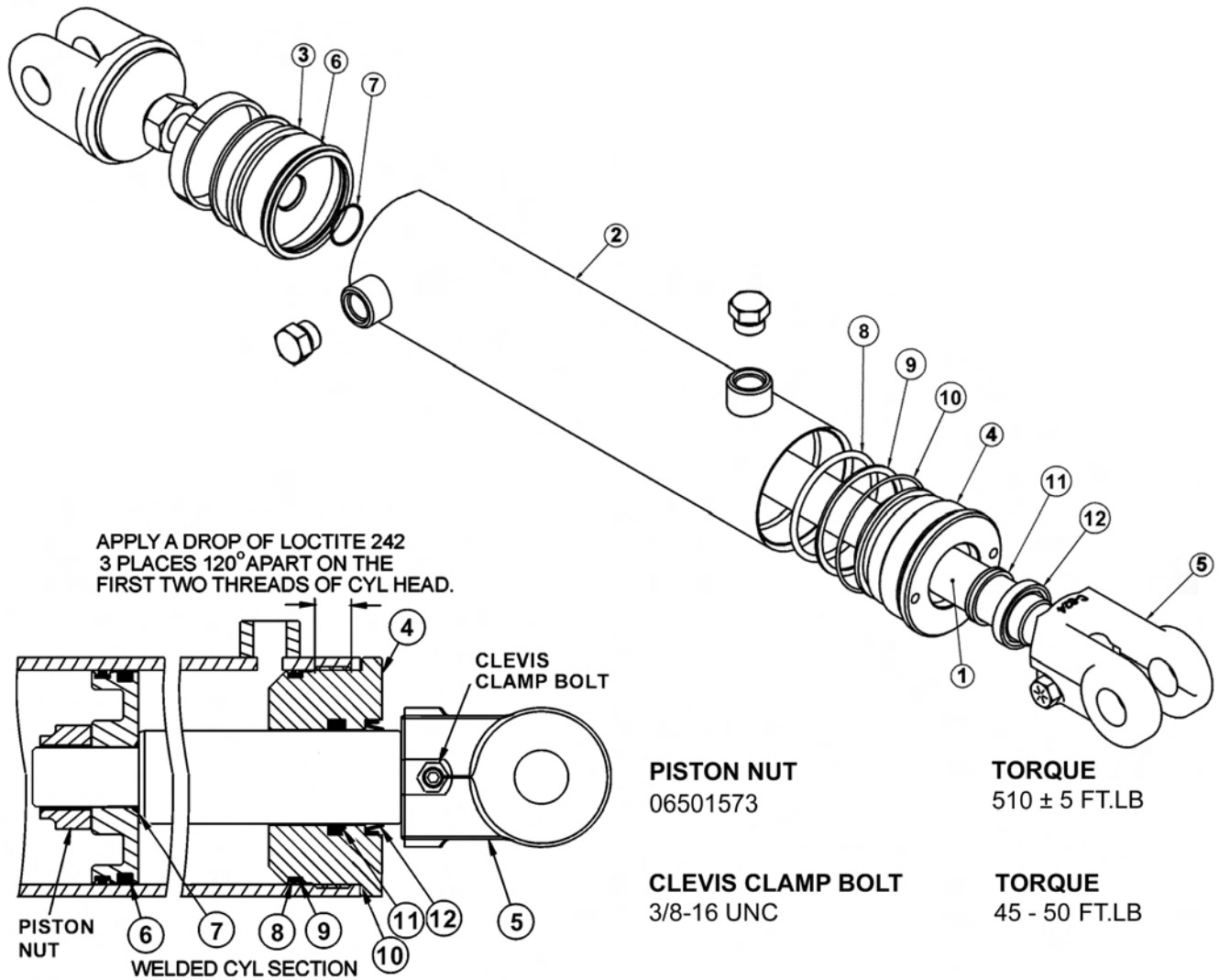

**WARNING - MECHANICAL FASTENERS MUST BE TORQUED TO RECOMMENDED SPECIFICATIONS DURING REPAIR TO PREVENT PERSONAL INJURY OR EQUIPMENT DAMAGE.**

ITEM	PART NO.	QTY.	DESCRIPTION
-----	06501022	-	HYDRAULIC CYLINDER COMPLETE
1	06501556	1	ROD
2	06501557	1	TUBE WELDMENT
3	06501558	1	PISTON
4	06501559	1	CYLINDER HEAD
5	6T0172	1	CLEVIS
5A	30172	-	CLEVIS (FOR EXTENDED BOOM)
-----	06501560	-	SEAL REPAIR KIT (ITEMS 6 THROUGH 12)

# NOTES

# COOLER ASSEMBLY

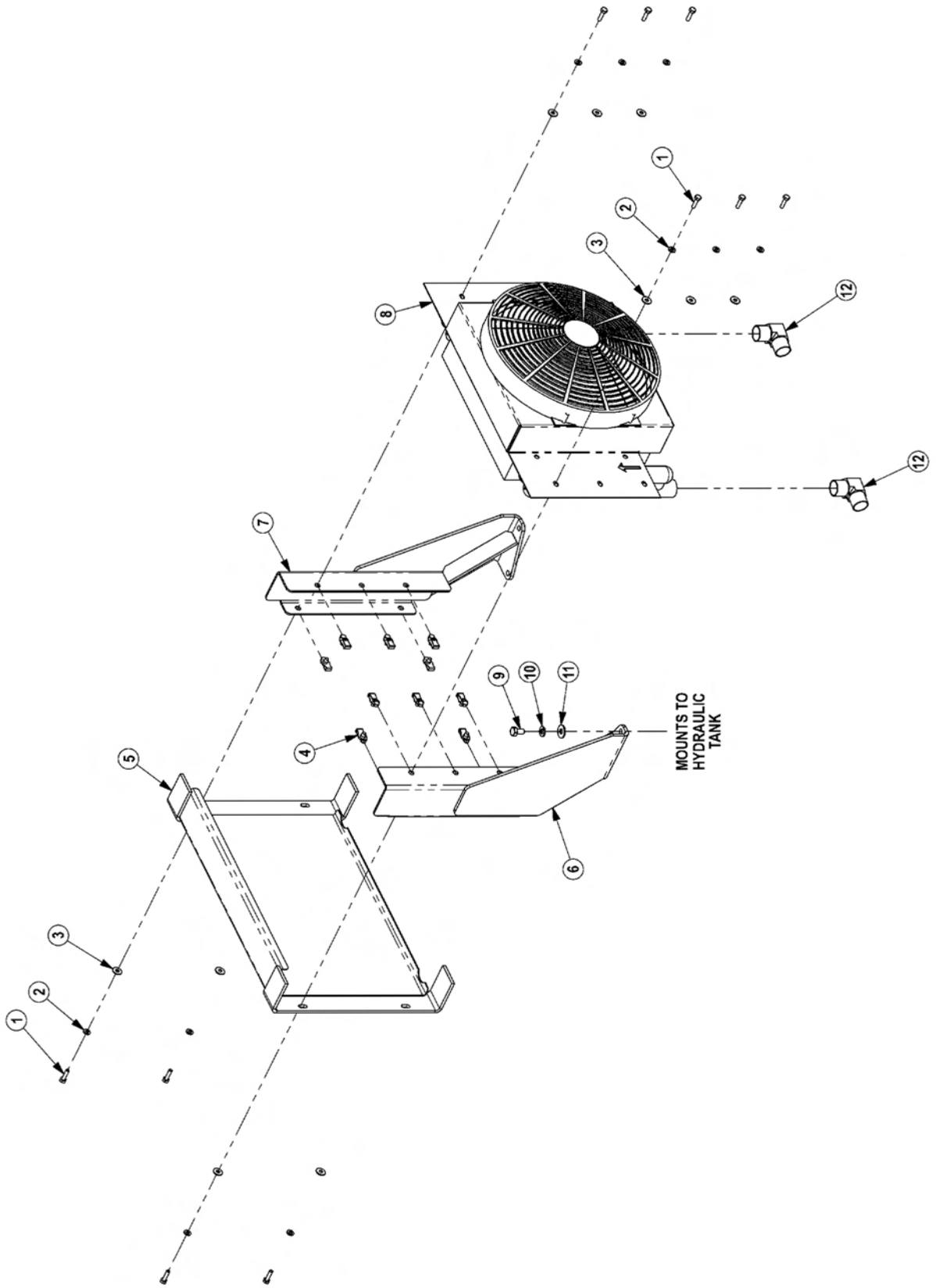

## COOLER ASSEMBLY

Continued...

ITEM	PART NO.	QTY.	DESCRIPTION
1	21530	10	CAPSCREW,1/4 X1 NC
2	21986	10	LOCKWASHER,1/4
3	22014	10	FLATWASHER,1/4
4	35176	10	1/4 U-NUT
5	06370015	1	SCREEN,COOLER,FRNT
6	06380006	1	MNT,COOLER,BUMPER TANK,RH
7	06380007	1	MNT,COOLER,BUMPER TANK,LH
8	06510026	1	COOLER,FRONT MNT
9	21629	4	CAPSCREW,3/8 X 3/4 NC
10	21988	4	LOCKWASHER,3/8
11	22016	4	FLATWASHER,3/8
12	34117	2	ELBOW,1MOR X 1MJ90,FORGED

COMMON LRS

# ROTARY MOWER SPINDLE ASSEMBLY

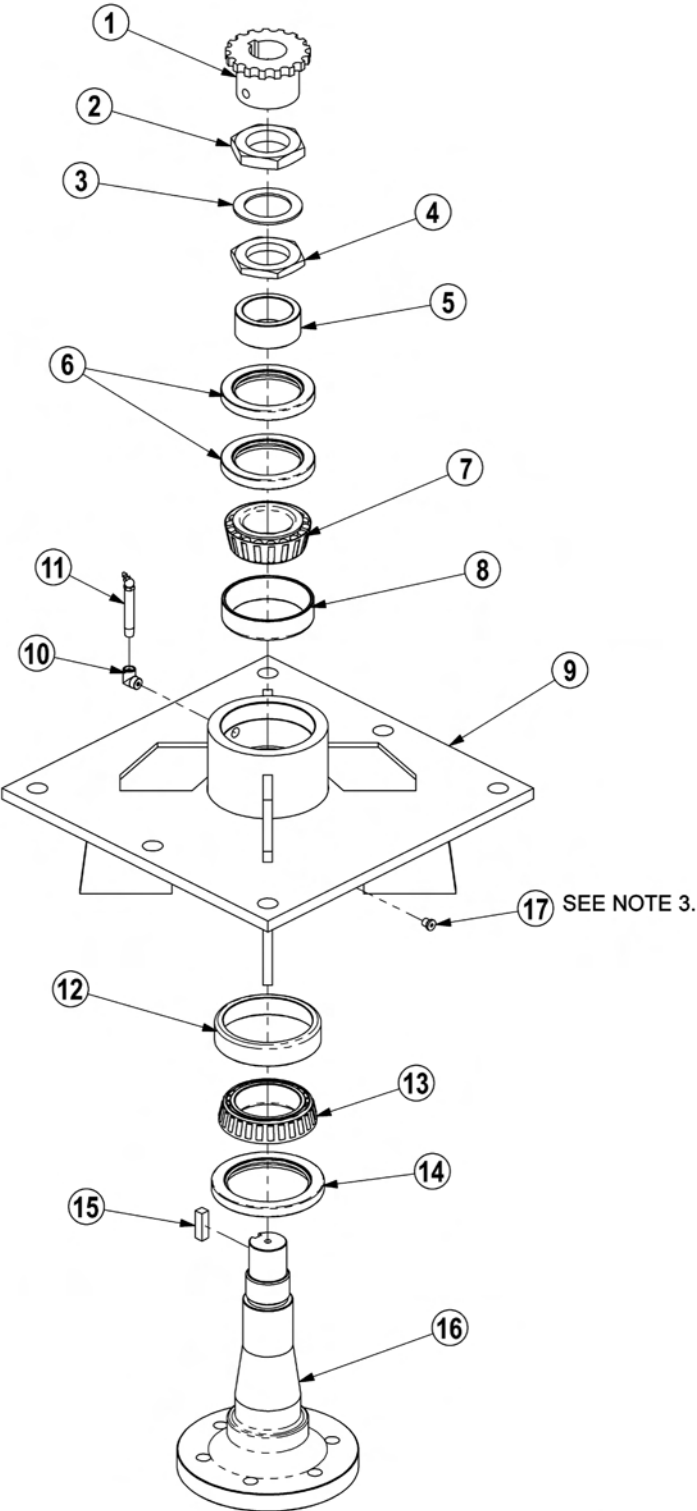

- NOTES:
1. FREEPLAY: .001" - .003"
  2. GREASE: FILL WITH MOBILITH SHC 220.
  3. APPLY LOCTITE "271" TO O-RING PLUG THRDS.

## ROTARY MOWER SPINDLE ASSEMBLY

Continued...

ITEM	PART NO.	QTY.	DESCRIPTION
-----	6T1024H5	-	SPINDLE ASSEMBLY COMPLETE
1	6T1031	1	SPROCKET
2	6T1016	1	BEARING LOCK NUT - THICK
3	22596	1	JAM WASHER
4	6T1015	1	BEARING ADJUSTMENT NUT - THIN
5	6T1014	1	BEARING ADJUSTMENT SLEEVE
6	6T1011	1	UPPER SEAL - SET OF 2
7	6T1012	1	BEARING CONE
8	6T1013	1	BEARING CUP
9	6T1010H	1	SPINDLE HOUSING
10	30570	1	FITTING STREET ELBOW
11	33990	1	GREASE ZERK
12	6T1013H	1	BEARING CUP
13	6T1012H	1	BEARING CONE
14	6T1011H	1	LOWER SEAL
15	6T1019	1	SPINDLE KEY
16	PT1018H-5	1	SPINDLE
17	06503064	1	O-RING PLUG, 1/8"
-----	33993	-	SPINDLE REBUILD KIT (INCLUDES ITEMS 2 - 8 AND 12 - 15)

COMMON LRS

## PUMP AND GRILL GUARD OPTIONS

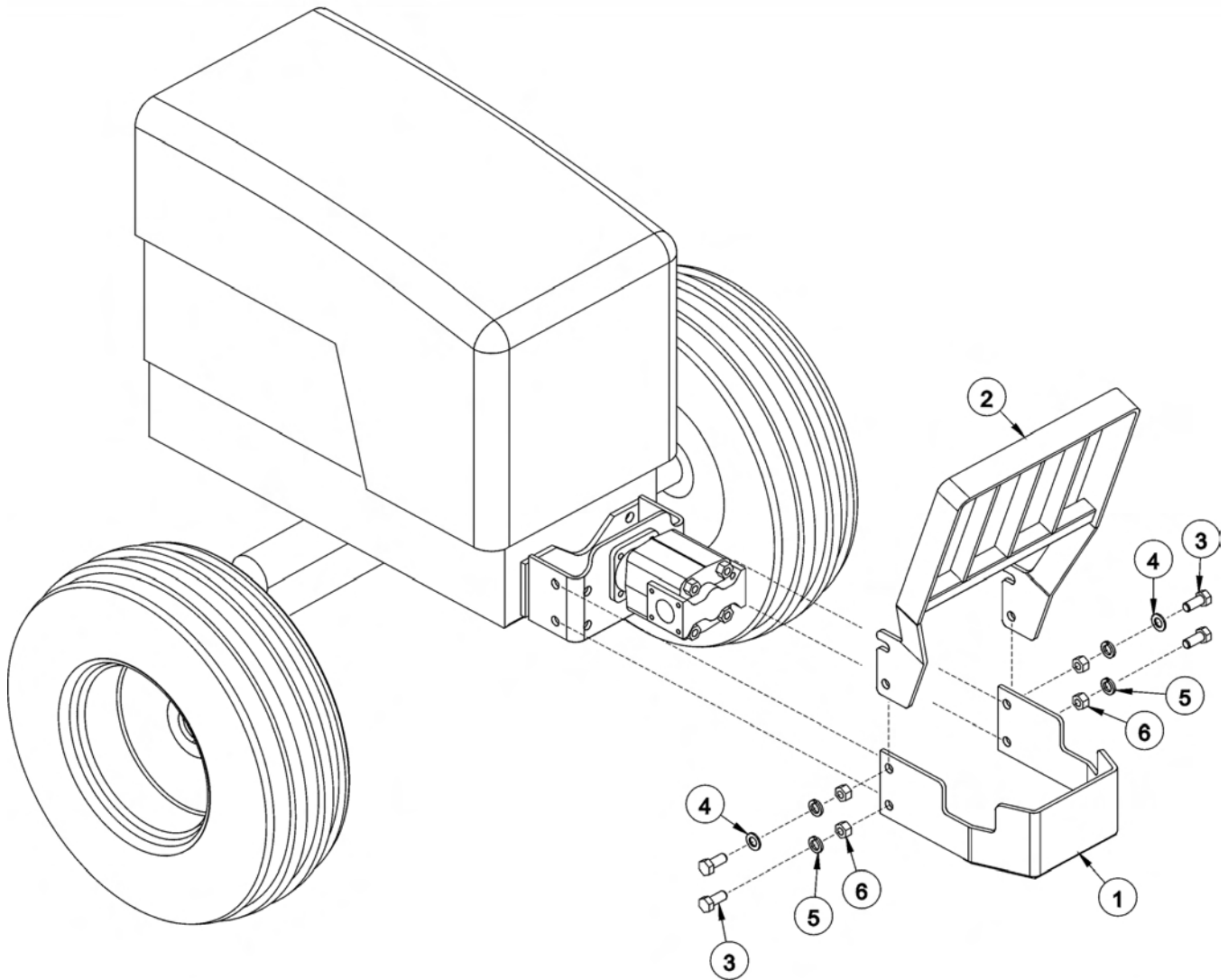

ITEM	PART NO.	QTY.	DESCRIPTION
1	32430	1	UNIVERSAL PUMP GUARD
2	32737	1	UNIVERSAL GRILL GUARD
3	21833	4	CAPSCREW,3/4" X 2-1/4",NC
4	22021	2	FLATWASHER,3/4"
5	21993	4	LOCKWASHER,3/4"
6	21825	4	HEX NUT,3/4",NC

COMMON LRS



## RESERVOIR TANK FILTER ASSEMBLY

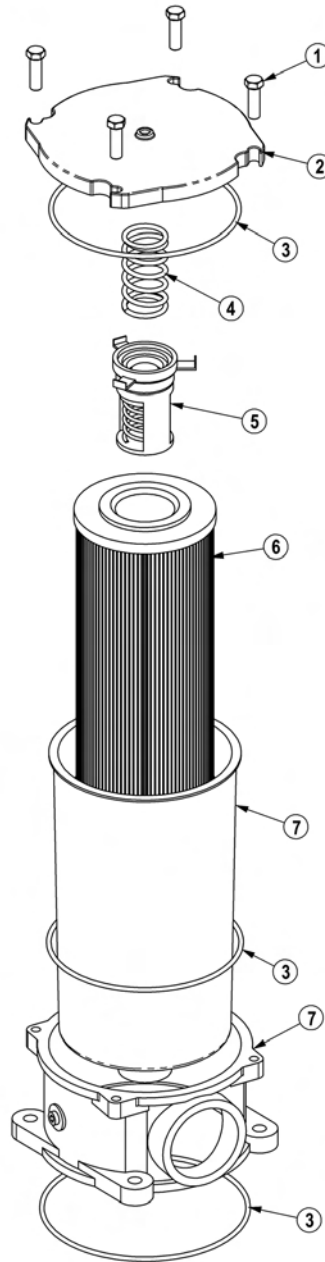

ITEM	PART NO.	QTY.	DESCRIPTION
-----	06505044	-	FILTER ASSY SAE 10 MICRON
1	28583	4	CAPSCREW,8MM X 25MM(1.25 PITCH)
2	06505045	1	COVER
3	06505046	1	SEAL KIT
4	06505047	1	SPRING
5	06505048	1	BYPASS
6	35259	1	FILTER,10 MIC,RETURN LINE
7	06505049	1	CAN/BODY

COMMON LRS

## 5 SPOOL ELECTRONIC VALVE - BENGAL BRUTE

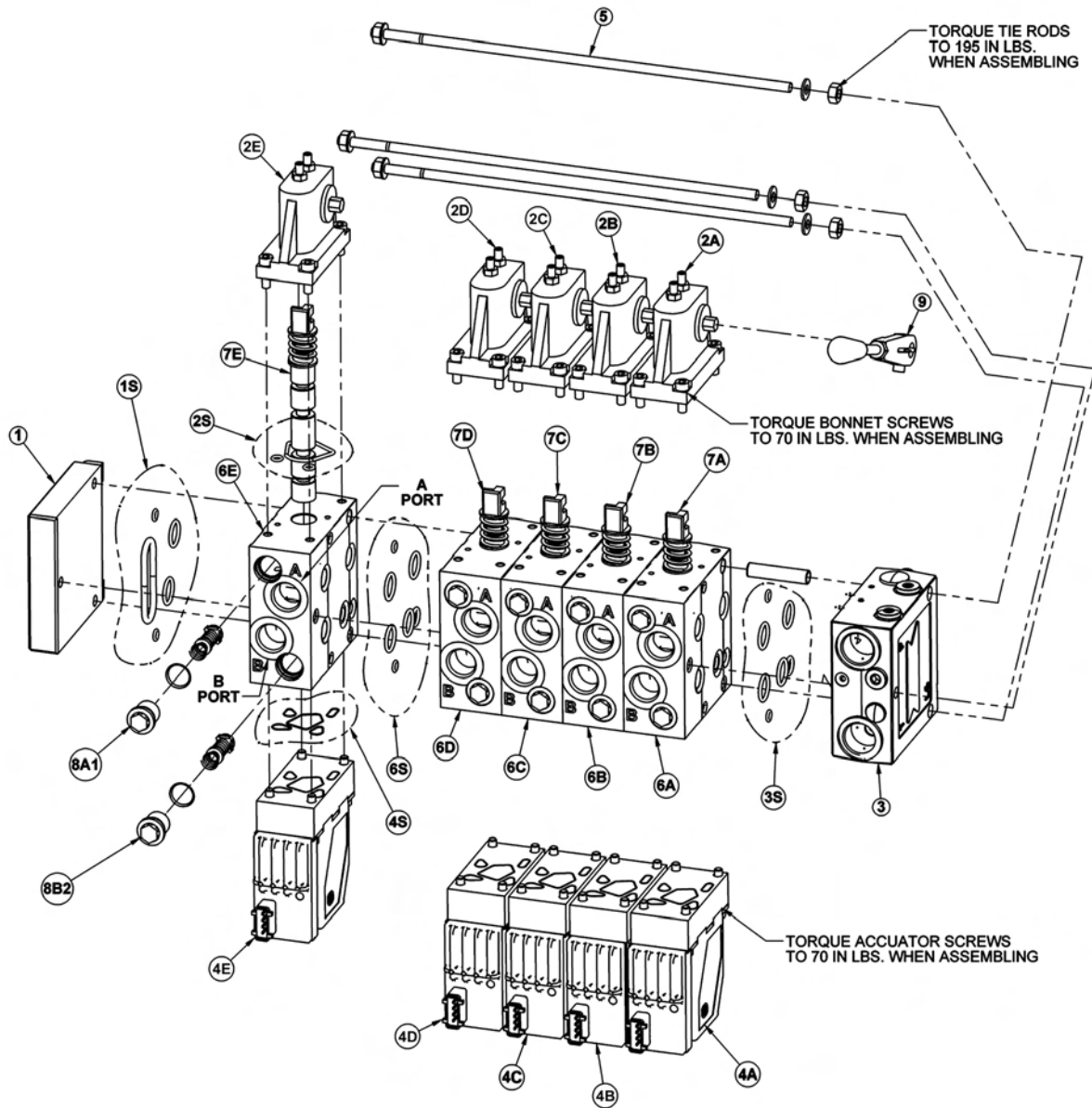

ITEM	PART NO.	QTY.	DESCRIPTION
-----	06502097	1	VLV,5SP,32PVG,REAR STOW
1	06502074	1	END PLATE
1S	06505013	1	END PLATE SEAL KIT
2	-----	5	BONNET
2S	06505042	1	BONNET SEAL KIT
2A	42197	1	MAIN BOOM BONNET
2B	42197	1	SECONDARY BOOM BONNET
2C	42197	1	DECK ROLL BONNET
2D	42197	1	BOOM SWIVEL BONNET
2E	42197	1	DECK SHIELD BONNET

COMMON LRS

## 5 SPOOL ELECTRONIC VALVE - BENGAL BRUTE

Continued...

ITEM	PART NO.	QTY.	DESCRIPTION
3	34308	1	INLET SECTION
3S	06505013	1	INLET SECTION SEAL KIT
4	-----	5	ELECTRONIC ACCUATOR
4A	06502101	1	MAIN BOOM ELECTRONIC ACCUATOR
4B	06502101	1	SECONDARY BOOM ELECTRONIC ACCUATOR
4C	06502100	1	DECK ROLL ELECTRONIC ACCUATOR
4D	06502101	1	BOOM SWIVEL ELECTRONIC ACCUATOR
4E	06502099	1	DECK SHIELD ELECTRONIC ACCUATOR
5	42202	1	TIE-BOLT KIT
6	-----	5	SECTION
6S	06505013	1	SECTION SEAL KIT
6A	42698	1	MAIN BOOM SECTION
6B	42698	1	SEC BOOM SECTION
6C	06502076	1	DECK ROLL SECTION
6D	42698	1	BOOM SWIVEL SECTION
6E	06502077	1	SHIELD SECTION
7	-----	5	SPOOL
7A	42697	1	MAIN BOOM SPOOL
7B	42697	1	SEC BOOM SPOOL
7C	4242106	1	DECK ROLL SPOOL
7D	06502073	1	BOOM SWIVEL SPOOL
7E	42201	1	DECK SHIELD SPOOL
8	-----	10	ANTI CAV/SHOCK RELIEF
8A1	06502084	1	MAIN BOOM A PORT RELIEF
8A2	06502081	1	MAIN BOOM B PORT RELIEF
8B1	42296	1	SEC BOOM A PORT RELIEF
8B2	06502082	1	SEC BOOM B PORT RELIEF
8C1	42295	1	DECK ROLL A PORT RELIEF
8C2	06502082	1	DECK ROLL B PORT RELIEF
8D1	06502070	1	BOOM SWIVEL A PORT RELIEF
8D2	06502083	1	BOOM SWIVEL B PORT RELIEF
8E1	06502081	1	DECK SHIELD A PORT RELIEF
8E2	06502081	1	DECK SHIELD B PORT RELIEF
9	33459	1	HANDLE

COMMON LRS

## 5 SPOOL ELECTRONIC VALVE - PANTHER

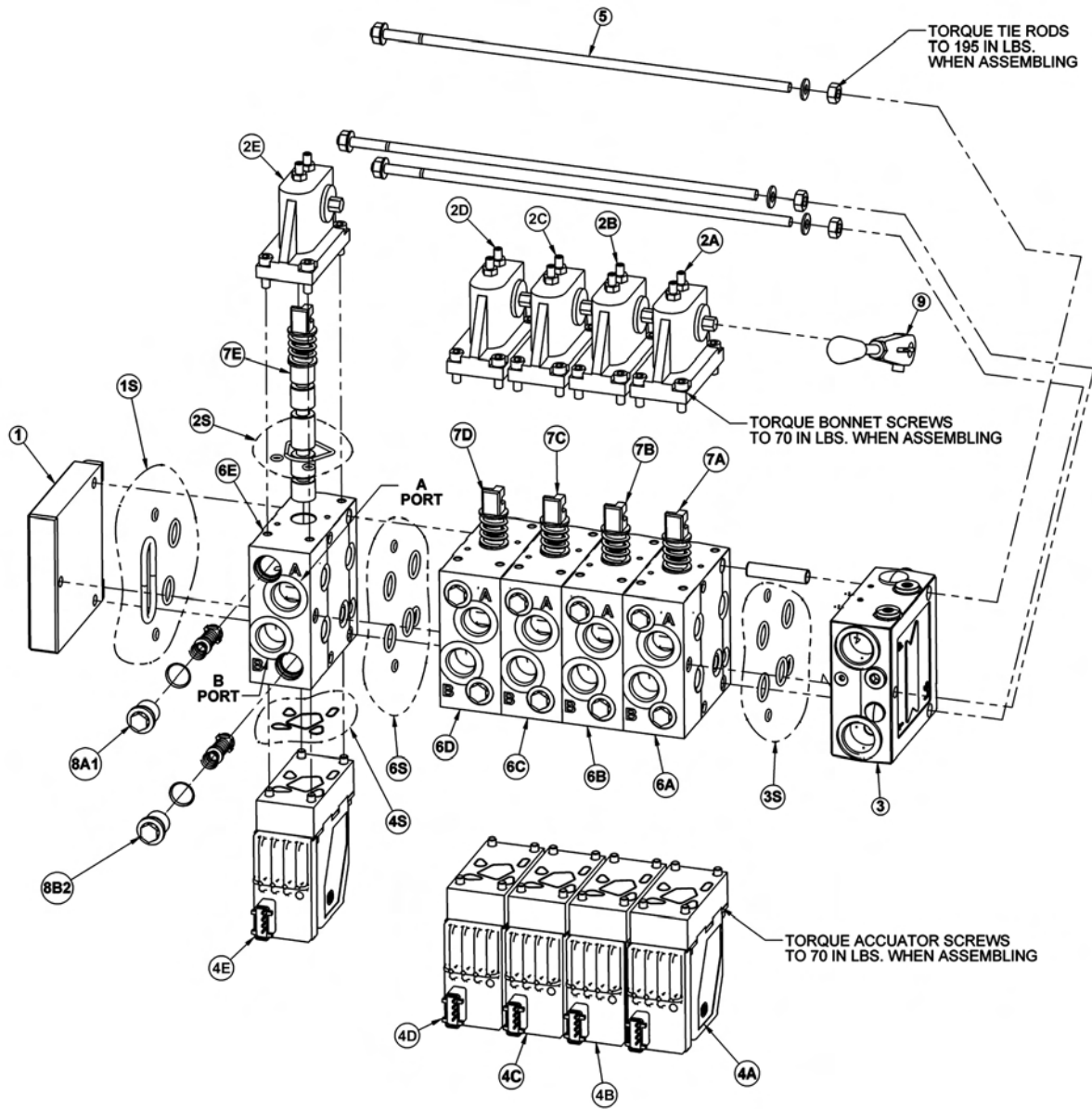

ITEM	PART NO.	QTY.	DESCRIPTION
-----	06502096	1	VLV,5SP,32PVG,PANTHER
1	06502074	1	END PLATE
1S	06505013	1	END PLATE SEAL KIT
2	-----	5	BONNET
2S	06505042	1	BONNET SEAL KIT
2A	42197	1	MAIN BOOM BONNET
2B	42197	1	SECONDARY BOOM BONNET
2C	42197	1	DECK ROLL BONNET
2D	42197	1	BOOM SWIVEL BONNET
2E	42197	1	DECK SHIELD BONNET

COMMON LRS

## 5 SPOOL ELECTRONIC VALVE - PANTHER

Continued...

ITEM	PART NO.	QTY.	DESCRIPTION
3	34308	1	INLET SECTION
3S	06505013	1	INLET SECTION SEAL KIT
4	-----	5	ELECTRONIC ACCUATOR
4A	06502101	1	MAIN BOOM ELECTRONIC ACCUATOR
4B	06502101	1	SECONDARY BOOM ELECTRONIC ACCUATOR
4C	06502100	1	DECK ROLL ELECTRONIC ACCUATOR
4D	06502101	1	BOOM SWIVEL ELECTRONIC ACCUATOR
4E	06502099	1	DECK SHIELD ELECTRONIC ACCUATOR
5	42202	1	TIE-BOLT KIT
6	-----	5	SECTION
6S	06505013	1	SECTION SEAL KIT
6A	42698	1	MAIN BOOM SECTION
6B	42698	1	SEC BOOM SECTION
6C	06502076	1	DECK ROLL SECTION
6D	42698	1	BOOM SWIVEL SECTION
6E	06502077	1	SHIELD SECTION
7	-----	5	SPOOL
7A	42697	1	MAIN BOOM SPOOL
7B	42697	1	SEC BOOM SPOOL
7C	4242106	1	DECK ROLL SPOOL
7D	06502073	1	BOOM SWIVEL SPOOL
7E	42201	1	DECK SHIELD SPOOL
8	-----	10	ANTI CAV/SHOCK RELIEF
8A1	42650	1	MAIN BOOM A PORT RELIEF
8A2	06502069	1	MAIN BOOM B PORT RELIEF
8B1	42650	1	SEC BOOM A PORT RELIEF
8B2	42295	1	SEC BOOM B PORT RELIEF
8C1	42296	1	DECK ROLL A PORT RELIEF
8C2	42295	1	DECK ROLL B PORT RELIEF
8D1	42295	1	BOOM SWIVEL A PORT RELIEF
8D2	42295	1	BOOM SWIVEL B PORT RELIEF
8E1	06502069	1	DECK SHIELD A PORT RELIEF
8E2	06502069	1	DECK SHIELD B PORT RELIEF
9	33459	1	HANDLE

COMMON LRS

# FRONT HYDRAULIC PUMP

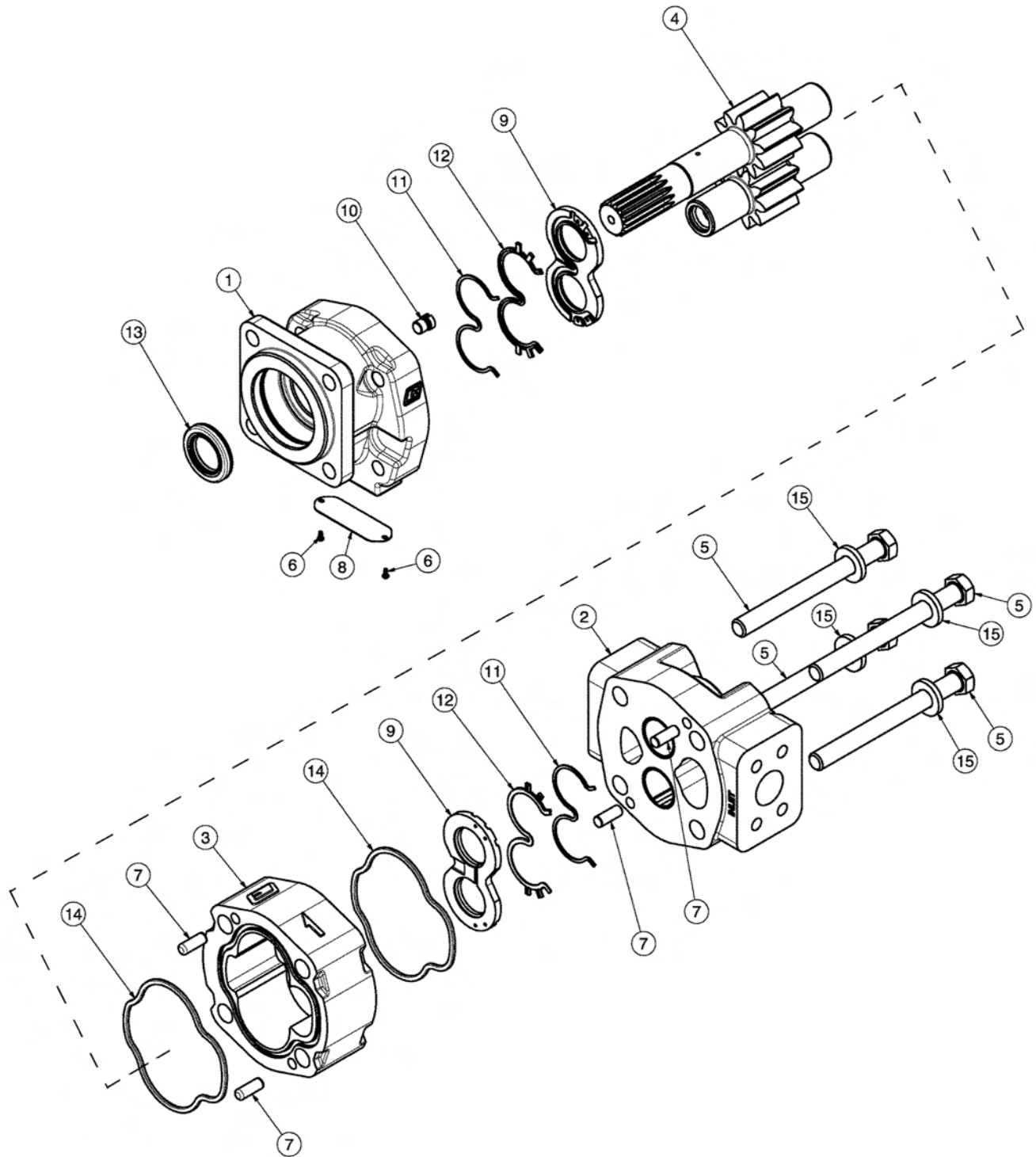

COMMON LRS

## FRONT HYDRAULIC PUMP

Continued...

ITEM	PART NO.	QTY.	DESCRIPTION
---	23152	1	PUMP ASSEMBLY,1-3/4",COMPLETE
1	22766	1	SHAFT END COVER
2	22779	1	PORT END COVER
3	22774	1	GEAR HOUSING,1-3/4"
4	22771	1	GEAR SET
5	23824	4	CAPSCREW
6	06504078	2	SCREW,DRIVE
7	22773	4	DOWEL PINS
8	06504077	1	NAMEPLATE
9	22770	2	THRUST PLATE
10	22767	1	PLUG
11	06504075	2	SEAL,BK-UP
12	06504074	2	SEAL,CHAN
13	22765	1	SEAL,LIP
14	06504076	2	SEAL,SQ-R
15	02961917	4	WASHER
---	24150	1	SEAL KIT (INCLUDES 11, 12, 13 AND 14)

COMMON LRS

# 50IN AND 60IN ROTARY MOTOR BREAKDOWN

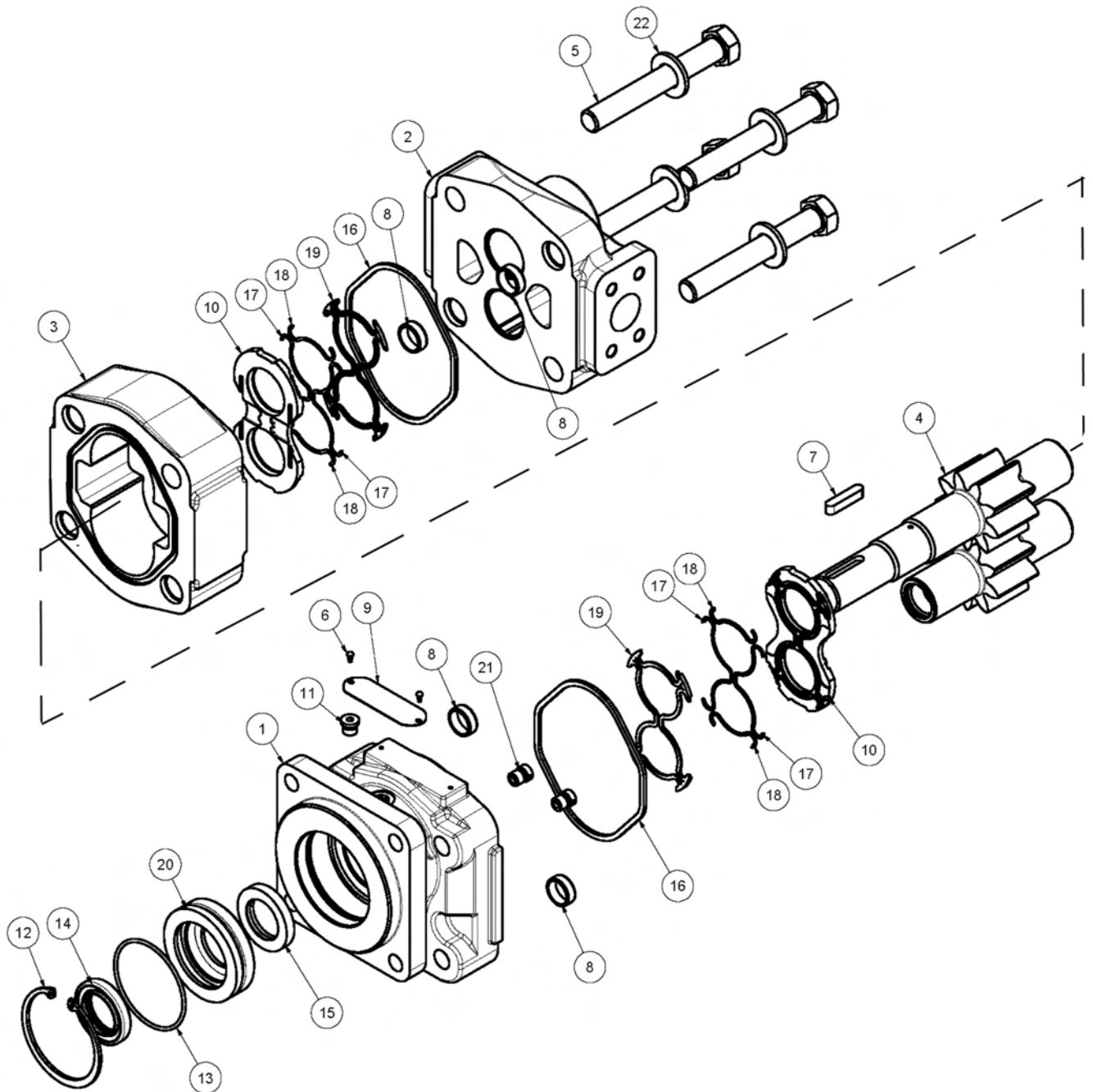

COMMON LRS



## 50IN AND 60IN ROTARY MOTOR BREAKDOWN

Continued...

ITEM	PART NO.	QTY.	DESCRIPTION
	06504011	-	MOTOR ASSEMBLY,TRB60
	06504012	-	MOTOR ASSEMBLY,TRB50
1	22790	1	HOUSING, SEC
2	06504088	1	HOUSING, PEC
3	06504062	1	HOUSING, GEAR,TRB60
-----	06504089	-	HOUSING, GEAR,TRB50
4	06504090	1	SET, GEAR SHAFT
5	06504104	4	CAP SCREW,TRB60
-----	06504091	-	CAP SCREW,TRB50
6	06504078	2	SCREW, DRIVE
7	06504092	1	KEY
8	06504093	4	PIN, DOWEL
9	06504094	1	NAME PLATE
10	06504095	2	THRPL
11	2961940	1	PLUG, ODT
12	2962200	1	RING, SNAP
13	06504096	1	O RING
14	6T5101	1	SEAL, LIP
15	06504097	1	SEAL, LIP
16	22797	2	SEAL, SQ-R
17	06504098	4	SEAL, SIDE CHAN
18	06504099	4	SEAL, END CHAN
19	06504100	2	SEAL, BK-UP
20	06504101	1	RTNR, SEAL
21	6T5809	2	CHECK ASS'Y
22	06504102	4	WASHER
-----	06504103	-	SEAL KIT

COMMON LRS

# 50IN AND 63IN FLAIL MOTOR BREAKDOWN

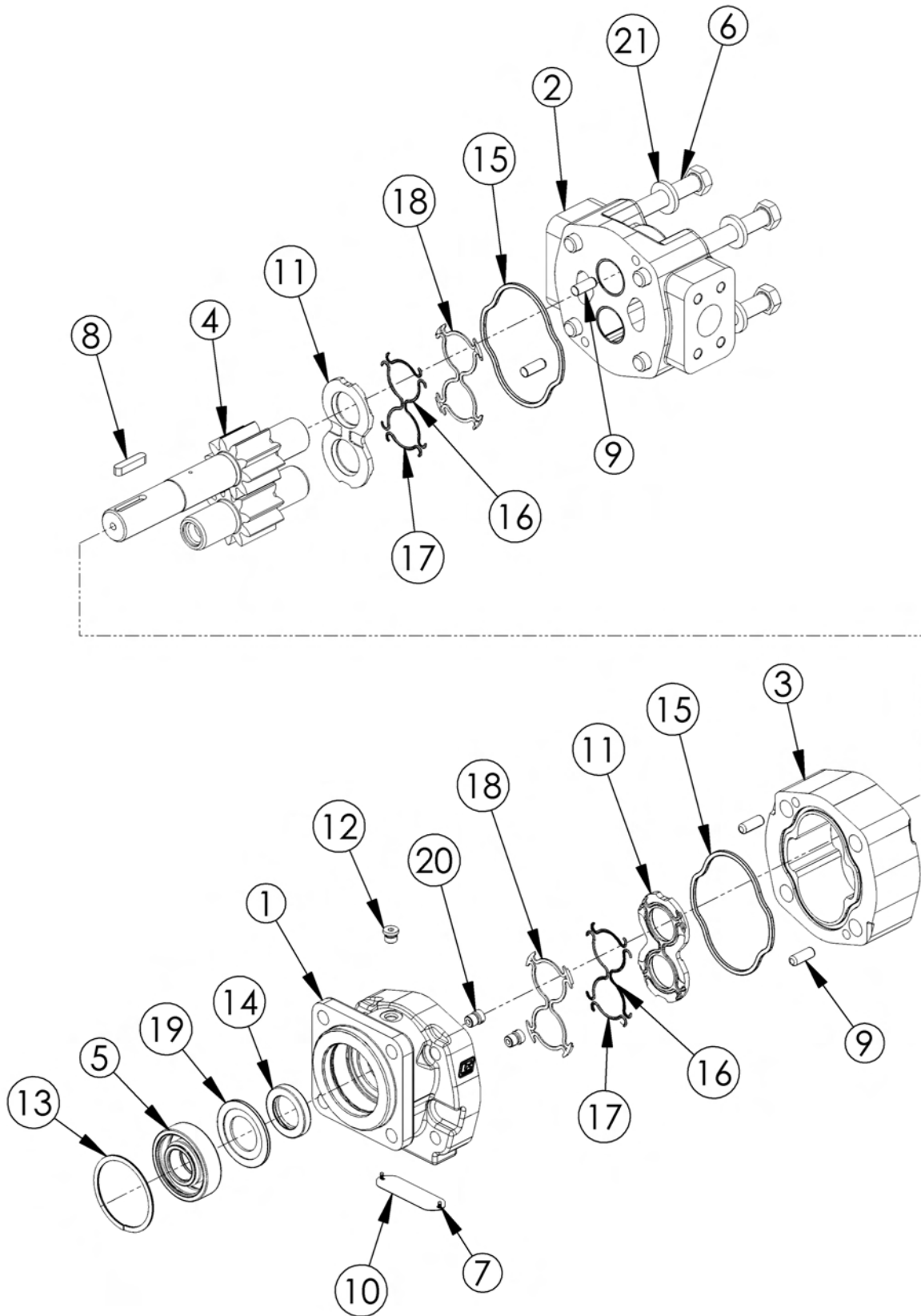

COMMON LRS

## 50IN AND 63IN FLAIL MOTOR BREAKDOWN

**Continued...**

<b>ITEM</b>	<b>PART NO.</b>	<b>QTY.</b>	<b>DESCRIPTION</b>
-----	06504013	-	MOTOR ASSEMBLY 350 - TBF50, TBF63
1	06504039	1	SHAFT END COVER
2	06504040	1	PORT END COVER
3	06504041	1	GEAR HOUSING
4	06504042	1	MATCHED GEAR SET
5	TF4402	1	BALL BEARING
6	06504043	4	CAP SCREW
7	06504044	2	SET SCREW
8	06504028	1	KEY
9	06504045	4	DOWEL PIN
10	-----	1	NAMEPLATE
11	763759	2	THRUSTPLATE
12	02961940	1	HEX PLUG
13	TF4401	1	SNAP RING
14	06504049	1	LIP SEAL
15	TF4410	2	GASKET SEAL
16	06504046	4	SIDE SEAL
17	06504047	4	END SEAL
18	TF4407	2	BACK-UP SEAL
19	06504048	1	SEAL RETAINER
20	6T5809	2	CHECK ASSEMBLY
21	02961917	4	WASHER
-----	06504023	-	SEAL KIT (INCLUDES 14, 15, 16, 17, AND 18)

COMMON LRS

## MANUAL LIFT VALVE SWITCH BOX

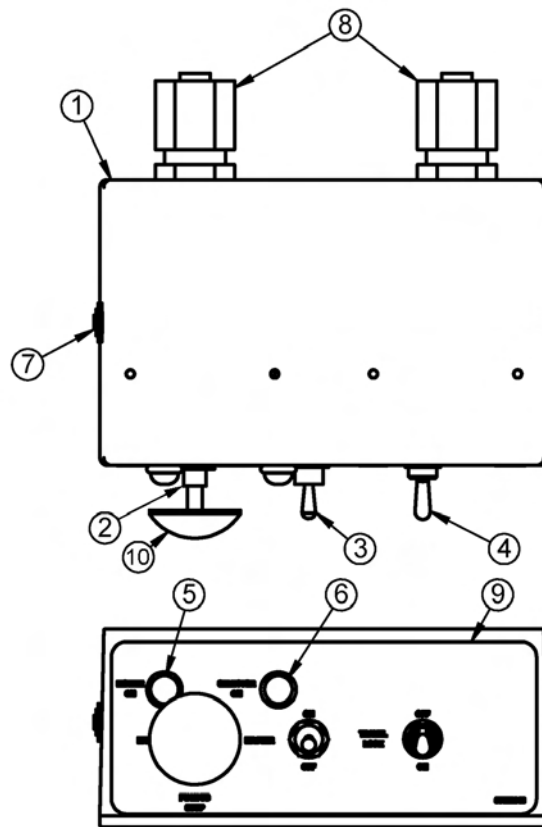

ITEM	PART NO.	QTY.	DESCRIPTION
1	06514010	1	SWBX, ASSY
2	35226	2	SWITCH, MOWER, COLEHERSEE
3	33811	1	SWITCH, MASTER/DECK FLOAT
4	34532	1	SWITCH, TRVL LCK
5	6T3923	1	INDICATOR LIGHT, ON, RED
6	06510193	1	INDICTATOR LIGHT, ON, GREEN
7	06514006	1	BREAKER, 15A, SWBX
8	34540	2	STRAIN RELIEF
9	06550043	1	DECAL, SWTCHBX
10	02964063	1	KNOB, RED
11	35227	1	RELAY, DP, DT, 12V, LY2F (NOT SHOWN)

# MANUAL LIFT VALVE SCHEMATIC

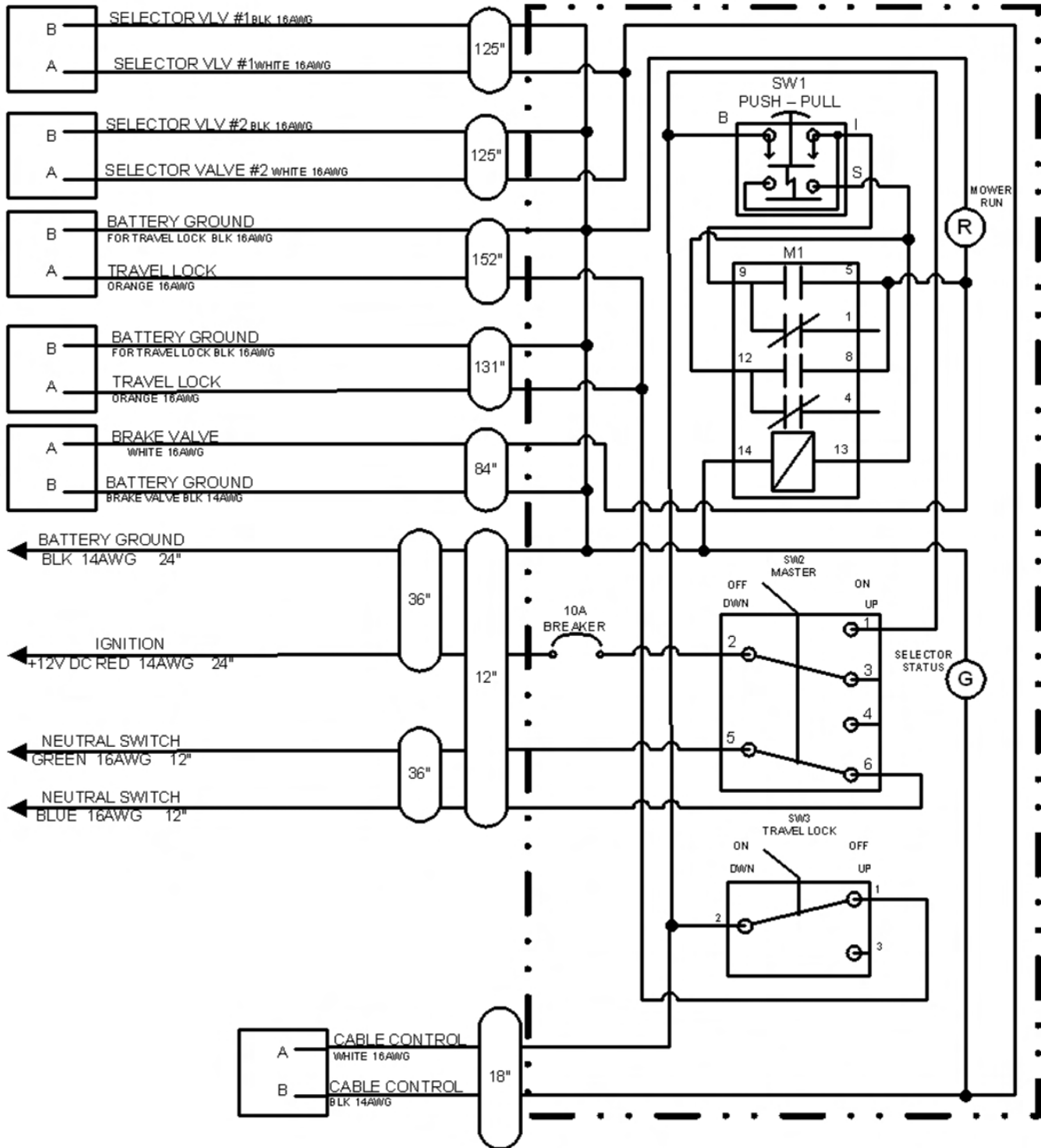

## ELECTRONIC LIFT VALVE SWITCH BOX

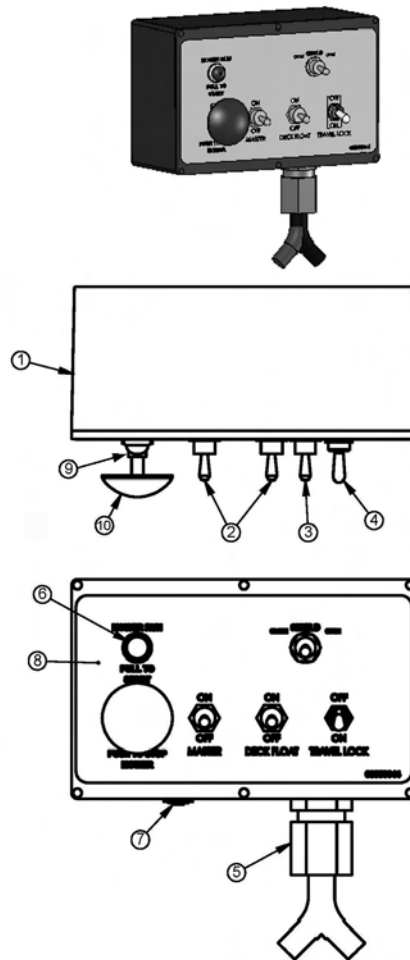

ITEM	PART NO.	QTY.	DESCRIPTION
1	06510195	1	SWBX,ASSY
2	33811	2	SWITCH,MASTER/DECK FLOAT
3	33813	1	SWITCH,SFTY SHIELD
4	34532	1	SWITCH,TRVL LCK
5	34540	1	STRAIN RELIEF,3/4",BLACK,NYLON
6	6T3923	1	INDICTATOR LIGHT,ON,RED
7	06514006	1	BREAKER,15A,SWBX
8	06550044	1	DECAL,SWBX,06510047
9	35226	1	SWITCH,MOWER,COLEHERSEE
10	35227	1	RELAY,DP,DT,12V,LY2F,35226

COMMON LRS

# ELECTRONIC LIFT VALVE SCHEMATIC - REAR STOW

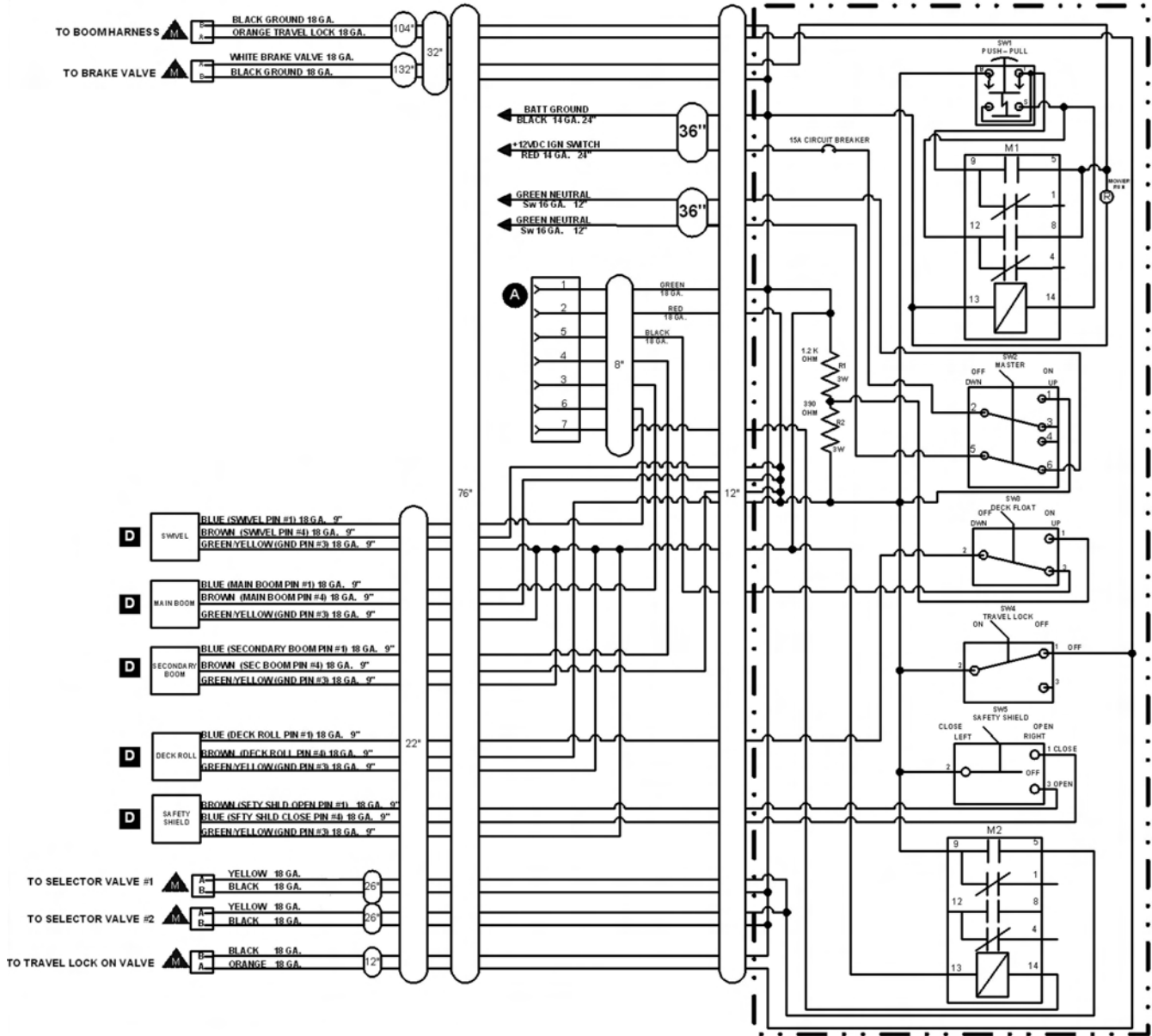

# ELECTRONIC LIFT VALVE WIRING DIAGRAM

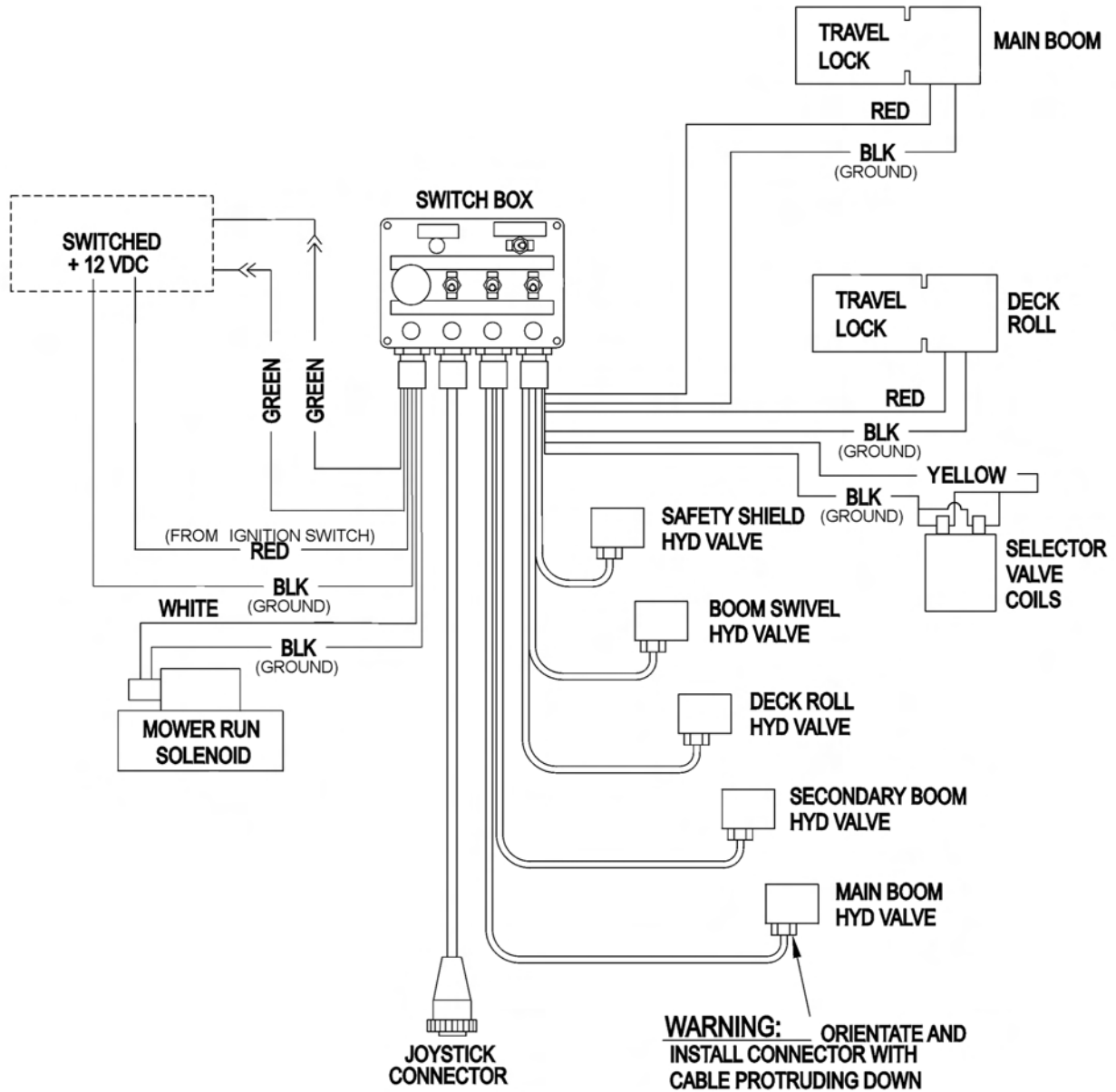



## BOOM TRAVEL LOCK

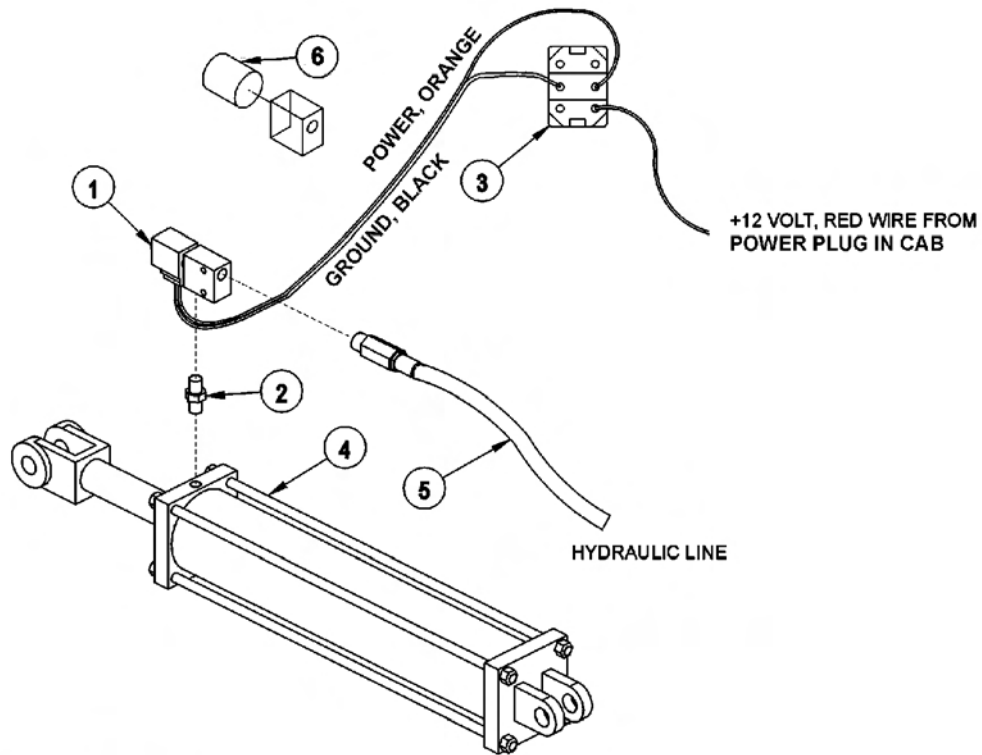

### DANFOSS SWITCH BOX



TRAVEL LOCK  
SWITCH

### HUSCO SWITCH BOX



TRAVEL LOCK  
SWITCH

ITEM	PART NO.	QTY.	DESCRIPTION
1	06510050	1	HYDRAULIC TRAVEL LOCK VALVE
2	31329	1	ADAPTER - STANDARD BOOM
3	34532	1	SWITCH,TRAVEL LOCK
4	-----	-	MAIN BOOM CYLINDER *REFER TO BOOM ASSY
5	-----	-	HOSE / FITTINGS *REFER TO BOOM HYD ASSY
6	06510092	1	COIL ,TRAVEL LOCK

COMMON LRS

# SELECTOR VALVE SCHEMATIC

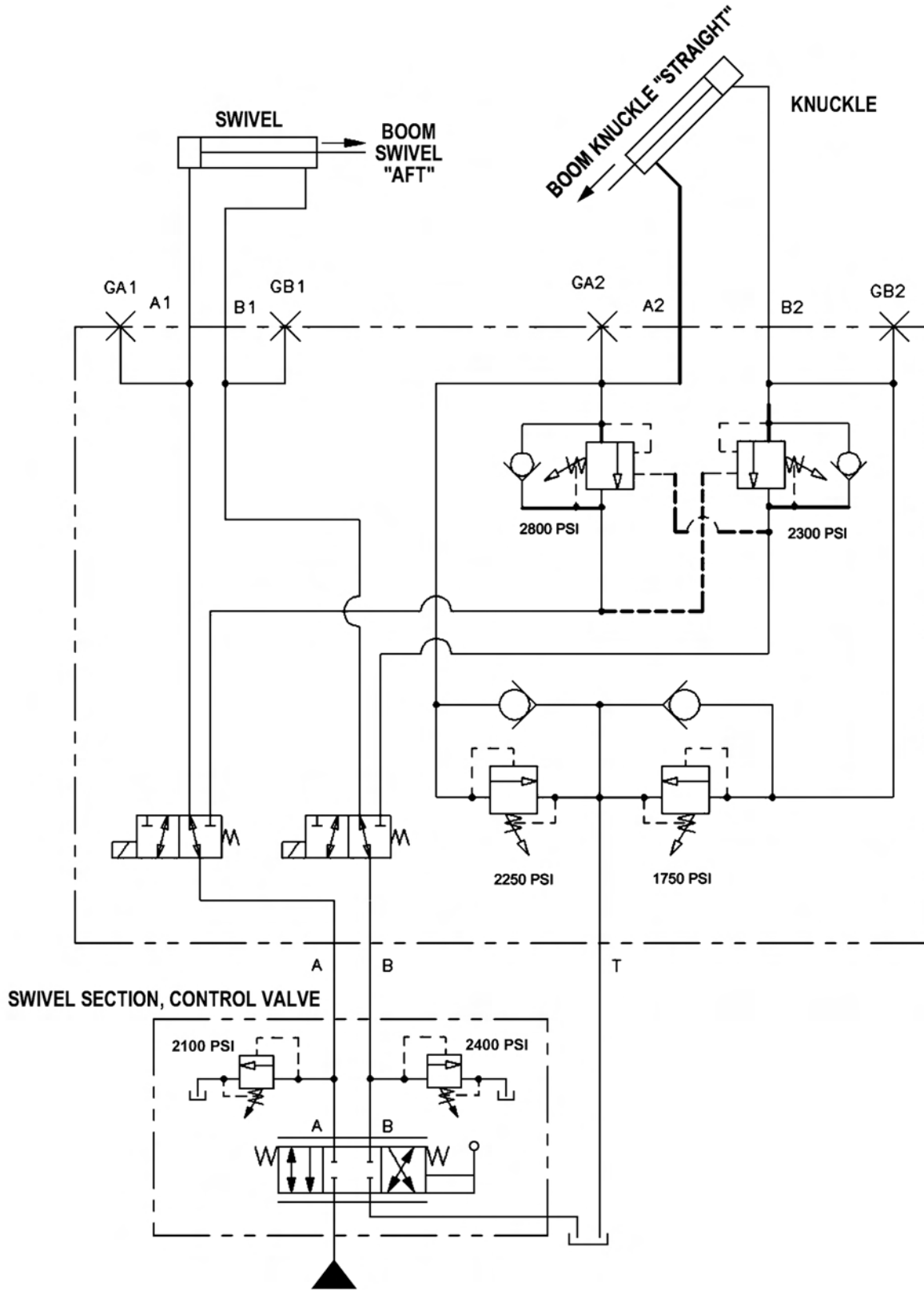

## BRAKE VALVE ASSEMBLY

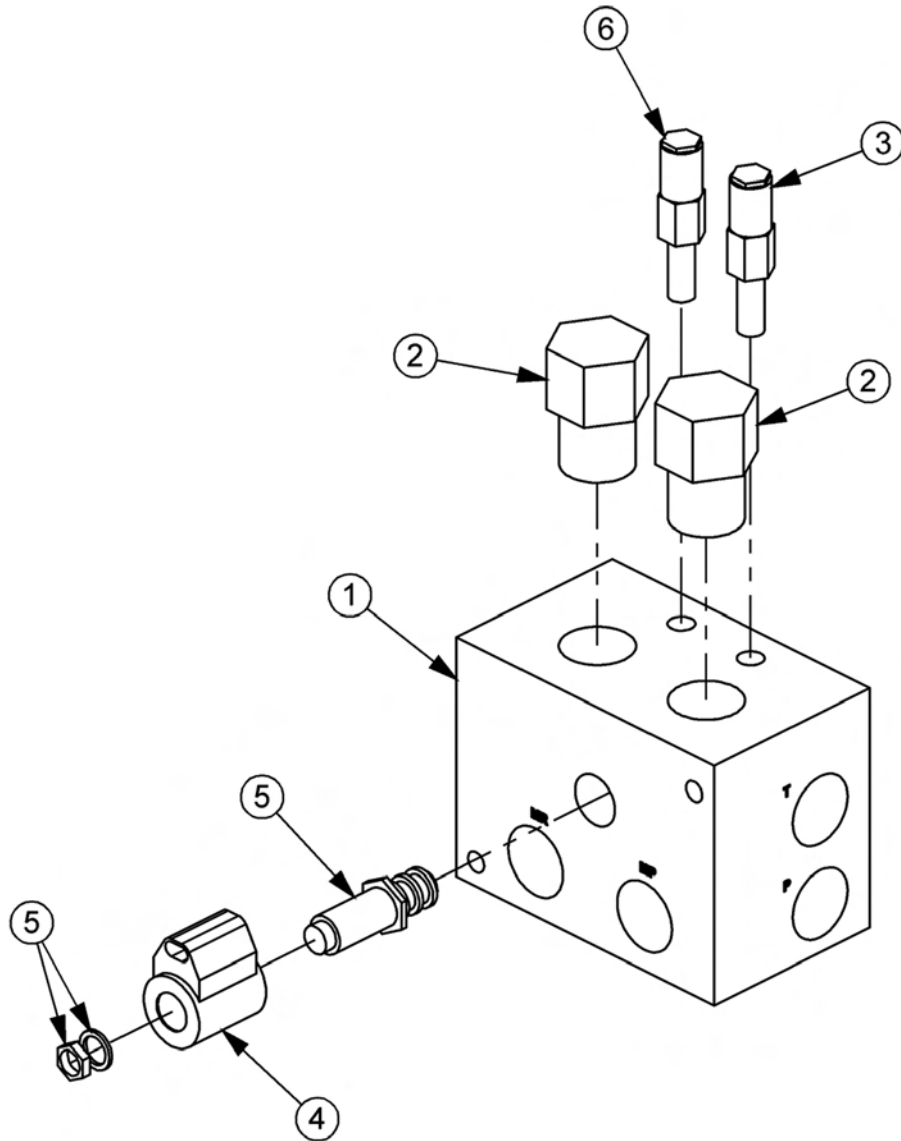

ITEM	PART NO.	QTY.	DESCRIPTION
---	06510083	1	BRAKE VALVE, ASSY
1	34092	1	BRAKE VALVE, BLANK
2	34094	2	LOGIC ELEMENT
3	34095	1	RELIEF VALVE, 3000 PSI
4	06510095	1	METRI PAK COIL
5	34093	1	CARTRIDGE, 2 POSITION, 3 WAY (WITH NUT & WASHER)
6	34091	1	RELIEF VALVE, 2600 PSI
---	34096	2	RELIEF SEAL KIT
----	34097	1	SOLENOID SEAL KIT
---	34098	2	ELEMENT SEAL KIT

COMMON LRS

## BRAKE VALVE HYDRAULIC SCHEMATIC

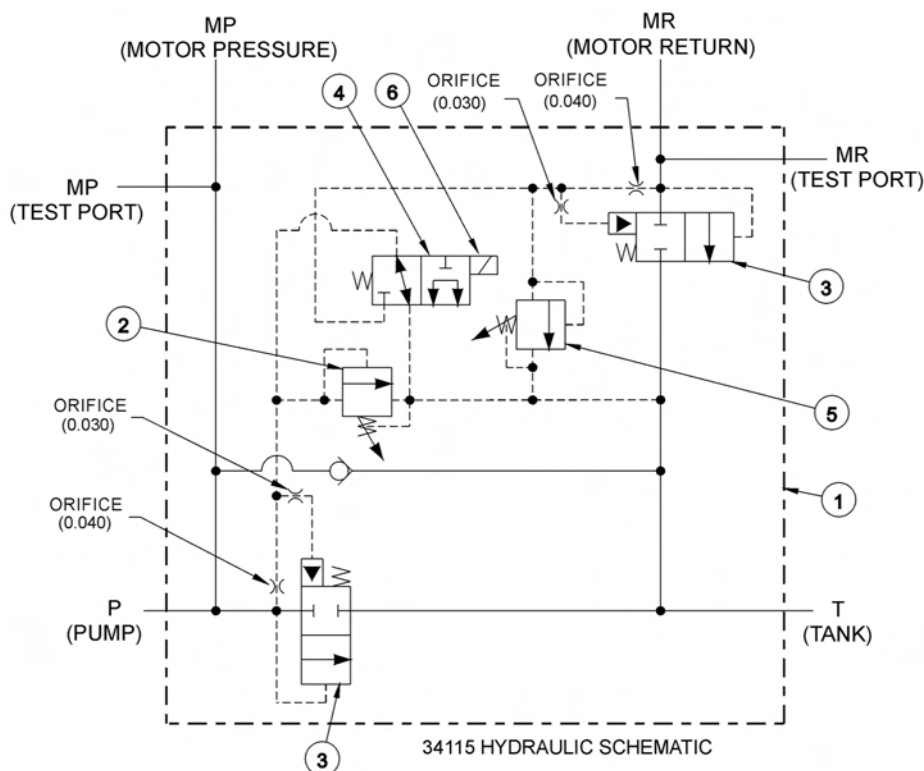

### BRAKE VALVE TROUBLESHOOTING

#### FAILURE MODE:

- MOWER WILL NOT START - system pressure is low (engine not lugging).
- MOWER WILL NOT START - system pressure is high (engine lugging). "MR" port will be high pressure.
- MOWER WILL NOT ROTATE AT FULL SPEED - limited power.
- MOWER BLADE WILL NOT STOP - blade will not stop in proper time.

#### CHECK STEPS

- 1 thru 6
- 7
- 3 thru 5
- 7 thru 9

#### CORRECTIVE STEPS:

1. Check for voltage at solenoid (item 6), voltage must be between 10.2 volts and 13.8 volts.
2. Remove, inspect solenoid and cartridge (items 4, 6) for wear or contamination.
3. Remove, inspect logic elements near "P" port (item 3) for wear or contamination.
4. Remove, inspect 3000 psi relief valve (item 2) for wear or contamination.
5. Remove and inspect orifices near "P" port for contamination.
6. Remove "P" port hose and fitting, visually inspect for contamination, check ball for movement.
7. Remove and inspect orifices near "MR" port for contamination.
8. Remove, inspect 2600 psi relief valve (item 5) for wear of contamination.
9. Remove, inspect logic element near "MR" port (item 3) for wear or contamination.

# HYDRAULIC TROUBLESHOOTING GUIDE

## Hydraulic Troubleshooting guide

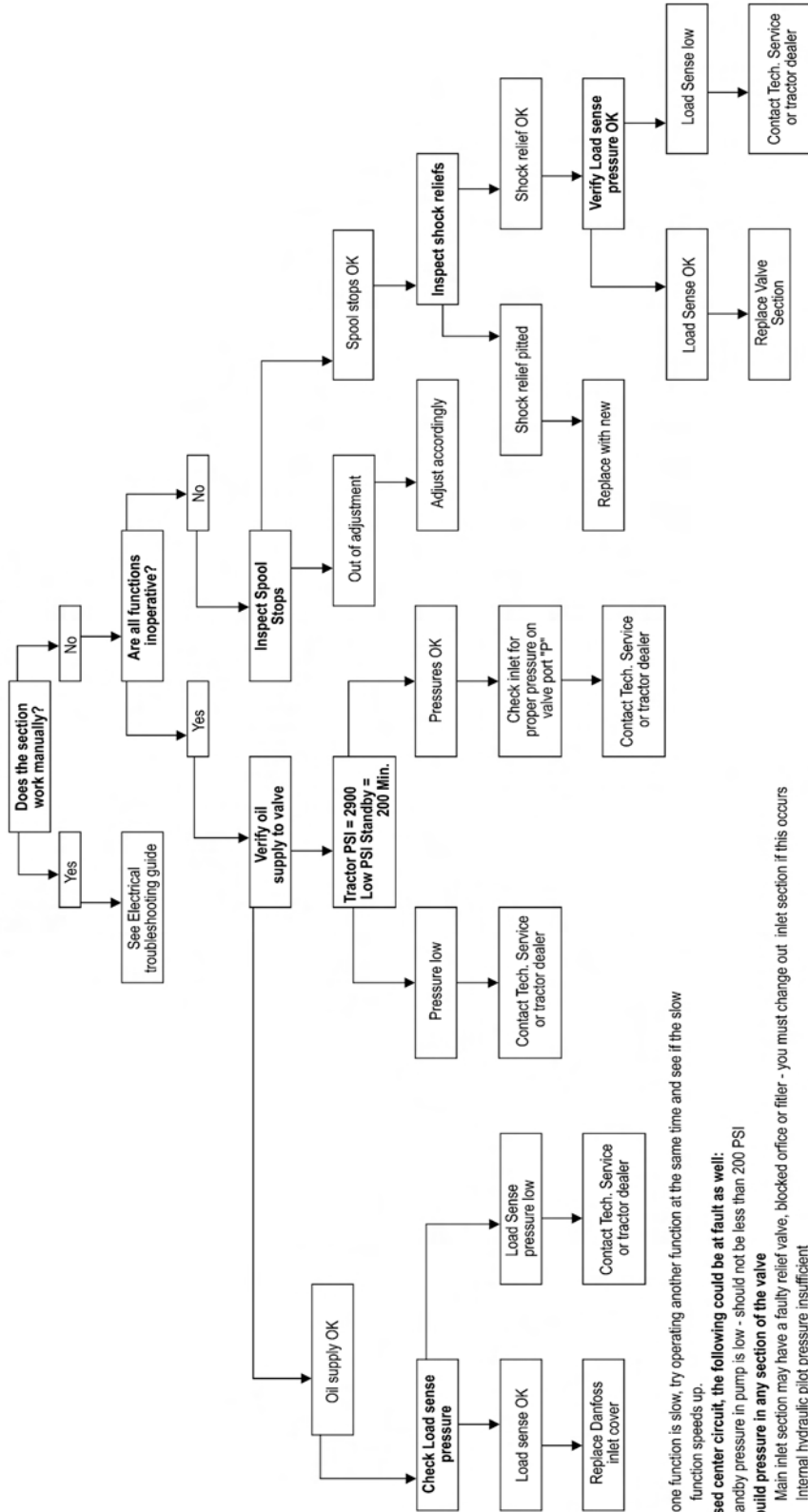

**Notes:** If one function is slow, try operating another function at the same time and see if the slow function speeds up.

**On a closed center circuit, the following could be at fault as well:**

Tractor standby pressure in pump is low - should not be less than 200 PSI

**Cannot build pressure in any section of the valve**

Main inlet section may have a faulty relief valve, blocked orifice or filter - you must change out inlet section if this occurs  
Internal hydraulic pilot pressure insufficient

# ELECTRICAL TROUBLESHOOTING GUIDE

## Joystick Electrical Troubleshooting guide

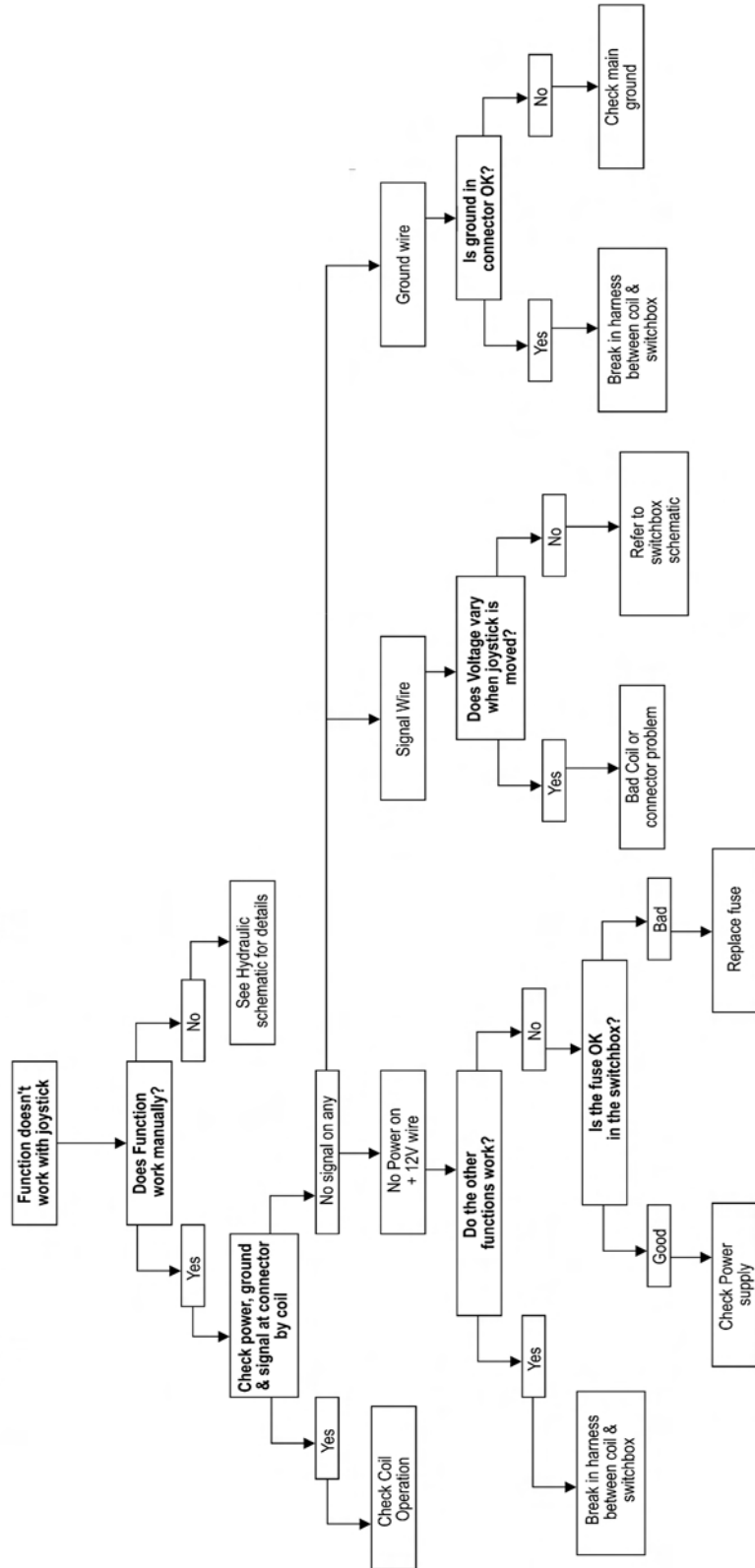

## TROUBLESHOOTING

### JOYSTICK TROUBLESHOOTING

Boom operation not responding to joystick movement.  
Isolate hydraulic vs. electronic symptom.

Turn off electronic master switch (preventing electronic actuator on valve from attempting to hold spool in neutral position). With tractor engine running, operate the valve section with the manual handle. If function operates normally, continue with electronic inspection. If function does not operate normally, continue with hydraulic inspection.

Electronic inspection.

Connect a voltmeter to the cable connector of the valve section that is not operating. This will allow you to measure supply and signal voltage when the joystick is operated.

Main, Secondary, and Swivel Valves – signal voltage should be 50% of supply voltage with joystick in Neutral position, up to 75% of supply voltage in B direction, down to 25% of supply voltage in A direction. Signal voltage should change smoothly with lever movement.

Pin #1 – Supply Voltage  
Pin #2 – Signal Voltage  
Pin #gnd – ground

Deck Roll Valve or Float Valve – signal voltage should be 50% of supply voltage with joystick in Neutral position, up to 65% of supply voltage in B direction, down to 35% of supply voltage in A direction. Signal voltage should change smoothly with lever movement. Signal voltage should be approximately 75% of supply voltage when float switch is operated.

Pin #1 – Supply Voltage  
Pin #2 – Signal Voltage  
Pin #gnd – ground

Shield Valve or On/Off Valve – Voltage on pin #1 should be equal to supply voltage when switch is operated in A direction. Voltage on pin #2 should be equal to supply voltage when switch is operated in B direction.

Pin #1 – Signal Voltage  
Pin #2 – Signal Voltage  
Pin #gnd – ground

If none of the valve will operate with electrical signal, verify that there is oil pressure at the valve inlet. Electrical Valves must have pilot supply oil to move the spools.

Possible electronic problems.

Open circuit (broken wire, bad connection or loose connection in switch box).

Shorted to positive, ground, or other.

Incorrect voltage signal from joystick.

**Continued on next sheet**

## TROUBLESHOOTING - CONTINUED

### Hydraulic inspection.

Install 3 pressure gauges, on the valve inlet (use M port, or tee into hose supplying oil from the pump to the inlet), on the workport that is not operating, and on the LS port.

With the spools in Neutral

Gear pump – P should be approximately 200 psi, LS = 0, workport – pressure on cylinder or function.

LS pump – P should equal pump standby pressure, LS = 0, workport – pressure on cylinder or function.

Pressure Comp pump – P should equal pump standby pressure, LS = 0, workport – pressure on cylinder or function.

Gear pump – P should be approximately 200 psi higher than LS, LS should equal workport, workport – pressure on cylinder or function.

LS pump – P should be LS + standby, LS should equal workport, workport – pressure on cylinder or function.

Pressure Comp pump – P should equal pump standby pressure, LS should equal workport, workport – pressure on cylinder or function.

Operate one spool, measure pressures with function at end of travel or stop

Gear pump – P should equal valve relief setting or workport shock valve setting. LS should equal workport. Workport should equal relief setting or workport shock valve setting.

LS pump – P should equal valve relief setting, pump max pressure setting, or workport shock valve setting. LS should equal workport. Workport should equal relief setting, pump max pressure setting, or workport shock valve setting.

Pressure Comp pump – P should equal pump standby pressure, LS should equal workport. Workport should equal pump standby pressure or workport shock valve setting.

Operate more than one spool.

Gear pump – P should be approximately 200 psi higher than LS. LS should equal highest workport pressure. Workport – pressure on cylinder or function.

LS pump – P should be LS + standby pressure. LS should equal highest workport pressure. Workport – pressure on cylinder or function.

Pressure Comp pump. P should equal pump standby pressure. LS should equal highest workport pressure. Workport – pressure on cylinder or function.

### Possible hydraulic problems.

Cylinder leak.

LS signal leaking to tank before reaching pump LS port.

Hydraulic system or pump not supplying flow to valve.



**CLEAN CUTTER HEAD**

**CLEAN CUTTER  
SECTION**

COMMON LRS

## CLEAN CUTTER ASSEMBLY

CAUTION!



Failure to follow the following warnings and instructions may result in serious injury or damage to the equipment or property!

CAUTION!



**WARNING:** The blade alone weighs approximately 145 lbs. Be sure its weight can be supported before attempting to replace. The use of a lift mechanism will ease replacement.

## CLEAN CUTTER BLADE MOUNTING

The CLEAN CUTTER blade was designed for installation onto a standard TRB50 spindle. It is equipped with replaceable carbide tipped teeth. Carbide is very hard, it will chip or break on impact. Handle the saw blade with care. **DO NOT** roll saw on any hard surface or allow it to strike a hard object. Set it down on a piece of belting or wood to avoid damaging carbide tips. Install two temporary(2) threaded studs into (2) opposite holes in the spindle. Align the bolt holes in adapter (part number 33875) with the studs and slide adapter over studs, be sure to index adapter so as the protruding 2 7/8" diameter pilot on the adapter faces outward away from spindle. Then slide the saw blade (part number 33874) over the studs and onto the 2 7/8" diameter pilot of the adapter. **NOTE:** Orient blade for clockwise rotation (blade rotates clockwise when looking down on top of mower deck). Then slide the collar (part number 33876) over the studs with the chamfered edge of collar to the outside, be sure the counterbore bolt holes face outward. Apply Loctite "271" to the threads of the 5/8-18 x 3" UNF Grade 8 bolts (part number 33877), and install lock washers (part number 21992) onto the bolts, then install bolts through collar, blade, and adapter into the spindle. Remove the threaded studs, and replace with bolts and lockwashers. Torque bolts in an alternating pattern to 184 Ft-lbs.

DANGER!



Never work under the Implement, the framework, or any lifted component unless the Implement is securely supported or blocked up to prevent sudden or inadvertent falling which could cause serious injury or even death.



## CLEAN CUTTER OPERATION

DANGER!



Never operate the Tractor or Implement until you have read and completely understand this Manual, the Tractor Operator's Manual, and each of the Safety Messages found in the Manual or on the Tractor and Implement. Learn how to stop the tractor engine suddenly in an emergency. Never allow inexperienced or untrained personnel to operate the Tractor and Implement without supervision. Make sure the operator has fully read and understood the manuals prior to operation.



## OPERATING INSTRUCTIONS

Inspect clean cutter saw before each use. Re-torque spindle bolts to 204 Ft-lbs. Inspect blade around collar and near the teeth for bends and cracks. Check for loose, broken, chipped, dull or missing teeth. Tighten all loose teeth by hammering and or replacing rivets. If teeth are broken, chipped, or missing or if blade is cracked or becomes bent remove blade and have it repaired at an approved service center. Call Tiger Service Department for replacement parts and service.

The TRB50 Clean Cutter is intended for clean cutting trees and brush up to six (6) inches in diameter maximum. Turn mower "ON" while tractor is running at idle RPM. Then increase tractor speed to 1,950 RPM maximum. Note, this tractor engine speed produces a mower speed of 1,500 RPM. **DO NOT operate the clean cutter mower at speeds in excess of 1,500 RPM.** If saw blade wobbles in excess of two (2) inches while tractor is idling, **STOP**, remove the blade and have it repaired in an approved service center. Call Tiger Service Department for replacement parts and service.

Allow saw to accelerate to maximum speed before moving into foliage. Advance mower head smoothly in foliage. Allow saw to cut through material, do not force or over feed. If saw slows excessively, move the head out of the foliage, and allow the saw to achieve maximum speed. **DO NOT** move up or down or roll mower head while cutting through heavy foliage. **DO NOT** use clean cutter mower on the ground. The saw blade is equipped with carbide tips, which are very hard. Striking rocks, steel, concrete, or other similar debris will break these tips.

Badly worn teeth increase stress to the saw blade and require more horsepower to cut than sharp teeth. Set-up a scheduled maintenance program for the saw before the teeth are dull. The saw will last longer, product a better cut, cut large diameter foliage without binding, and will cost less to operate.

Check adapter and collar every time saw is changed, maintain the .004 inch taper on face (surface against the saw blade) of these two (2) items. Always clean adapter and collar before mounting the blade. If adapter or collars are worn or damaged, they must be replaced.

**Familiarize yourself with the machines operation and correct operating safety precautions.**

## CLEAN CUTTER OPERATION - CONTINUED

**WARNING!**



Excessive wobble will generate heat in the blade, rapidly accelerating the loss of tension. The overheated blade will then rub against the foliage as it is cutting, again increasing the heat in the blade and intensifying the wobble. The blade may then weaken, crack and eventually fail. **NEVER RUN A BLADE THAT IS CRACKED OF BENT.**

**DANGER!**



Always keep a careful lookout and use extreme care when working around overhead obstructions. Never allow the Mower head or boom within 10 feet of any power line. When working close to overhead power lines consult your electric company for a safe code of operation.



**WARNING!**



Do not put hands or feet under mower decks. Blade Contact can result serious injury or even death. Stay away until all motion has stopped and the decks are securely blocked up.



**DANGER!**



Never operate the Tractor and Mower Unit without an OPS (Operators Protective Structure) or Cab to prevent injury from objects thrown from ground or from overhead trimming. Stop mowing if workers or passersby are within 100 yards.



**WARNING!**



**CAUTION:** Never leave the key in the ignition switch. Also personal injury or death can occur from sudden dropping or inadvertent operation of the controls. Make certain the area is clear before lowering or raising the deck.

## MAINTENANCE INSTRUCTIONS

Inspect clean cutter saw before each use. Re-torque spindle bolts in an alternating pattern to 204 ft-lbs. Check for loose, broken, chipped, dull or missing teeth. Tighten all loose tooth assemblies by hammer and or replacing rivets. If teeth tips are broken, chipped, or missing, replace tip or replace entire tooth assembly. **NEVER RUN SAW BLADE WITH MISSING TOOTH ASSEMBLY.** If saw blade is cracked, becomes bent or wobbles in excess of two (2) inches while the tractor is idling, **STOP**, remove blade and have it repaired at an approved service center. Call Tiger Service Department for replacement parts and service.

These saw blades are pre-tensioned after the tooth assemblies are riveted in place. This pre-tensioning ensures that the blade runs true and remains true under normal cutting load. Removal of more than one or two complete tooth assemblies at a time may effect the tensioning of the blade. Before cutting always check for wobble while machine is running at idle. If blade wobbles in excess of two (2) inches, **STOP**, remove blade and have it repaired at an approved service center. The teeth tips can be replaced without removing the tooth bodies from the saw blade (see TIP REPLACEMENT PROCEDURE). This method is preferred over the entire removal of tooth assemblies.

Check adapter and collar every time saw is changed, maintain the .004 to .006 inch taper (see figure below) on inside face (surface against saw blade) of these two (2) items. Always clean inside face of adapter and collar before mounting the blade. If adapter or collars are worn, chipped, or damaged, they must be replaced.

**Any saw blade (regardless of condition) that has seen regular use should be serviced at least once a year at an approved service center.**

Spare saw blades should be stored in a dry environment and transported only on the wooden crates that are supplied with the saw blade.

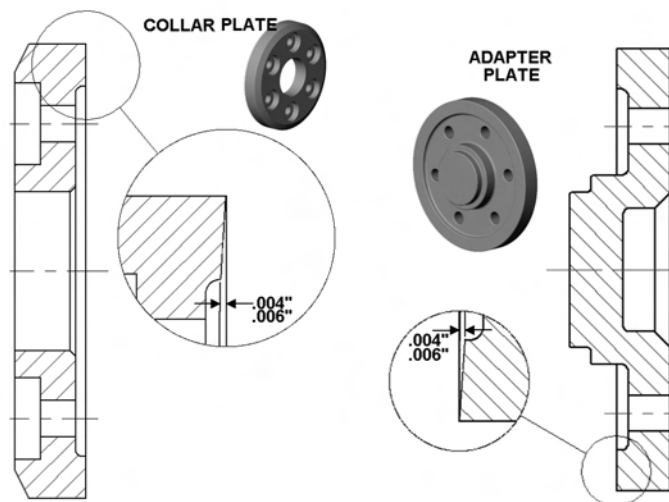

## CLEAN CUTTER BLADE AND TEETH PARTS

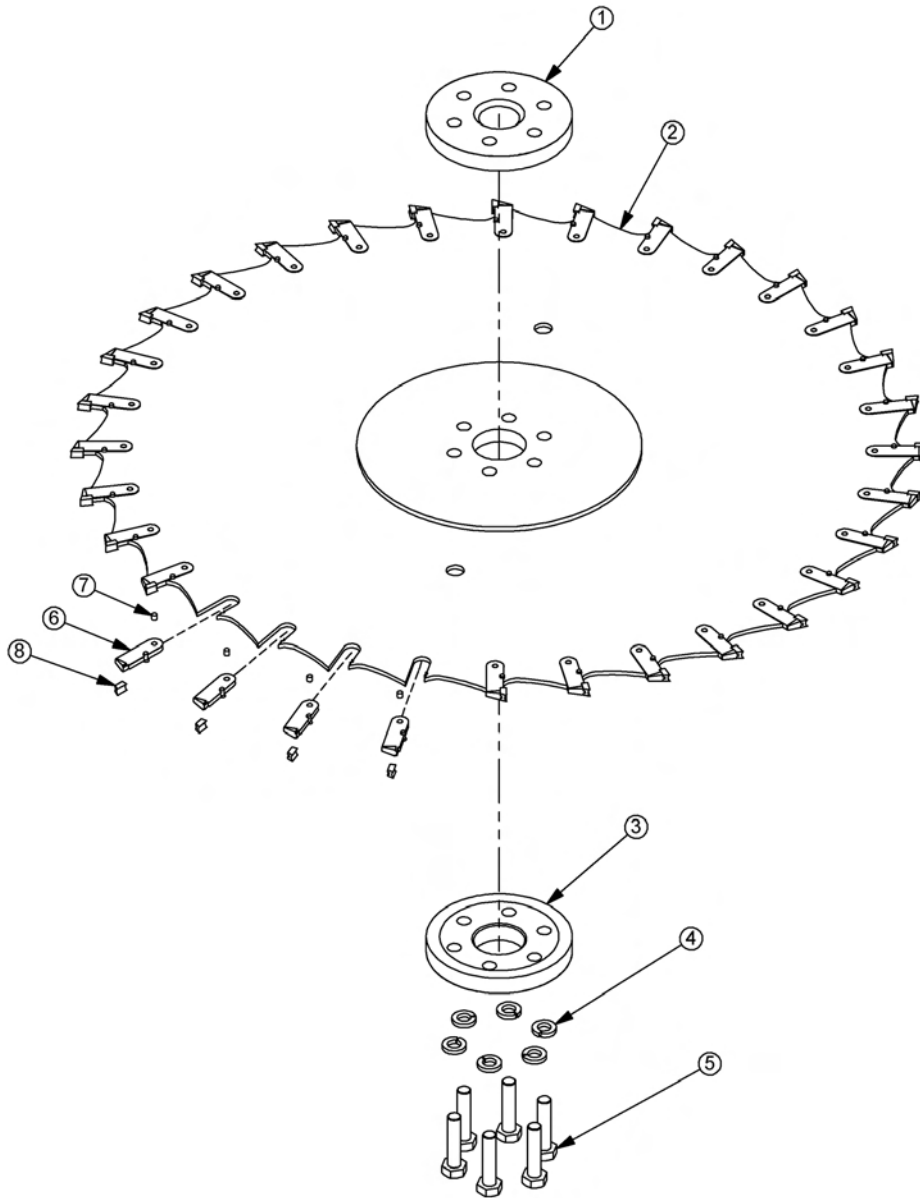

ITEM	PART NO.	QTY.	DESCRIPTION
1	06420024	1	ADAPTER,SAW,TRB50,RNFRCD
2	06520224	1	BLADE, 48" SAW WITH TEETH
3	06420037	1	COLLAR,SAW,TRB50,RNFRCD
4	33764	6	FLATWASHER,5/8,GR 8,SAE
5	06530209	6	CAPSCREW,5/8 X 3 3/4 NF, GR 8
6	06520225	30	TOOTH WITH RIVET, SAW BLADE
7	34703	30	TOOTH RIVET, SAW BLADE
-----	34704	-	RIVET REMOVER TOOL (NOT SHOWN)
8	34702	30	TOOTH TIP, SAW, CARBIDE
-----	34705	-	SHARPENING TOOL (NOT SHOWN)

COMMON LRS

## CARBIDE TIP REPLACEMENT

1. Heat face of tip to dull orange, remove tip, then brush tooth body clean of all debris (carbon).
2. Apply acetone to socket rail on tooth body and allow it to evaporate. Dab on soldering paste (black flux) to socket rail of tooth body and slide pre-tinned tip into place.
3. Then heat tip sides and base of socket rail to ensure silver solder flows completely around base of tip. Grasp tip with tweezers and gently twist tip back and forth to ensure complete bonding of silver solder.
4. Discontinue heat, and allow to cool. Then check braze by gently tapping tip with rubber mallet.

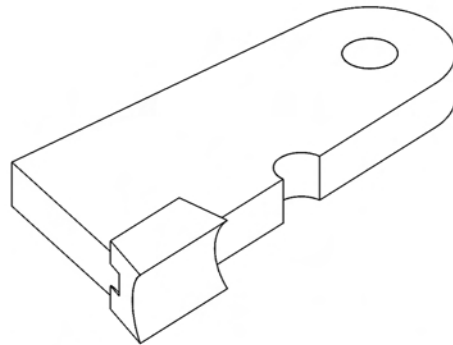

VIEW OF ASSEMBLED TOOTH

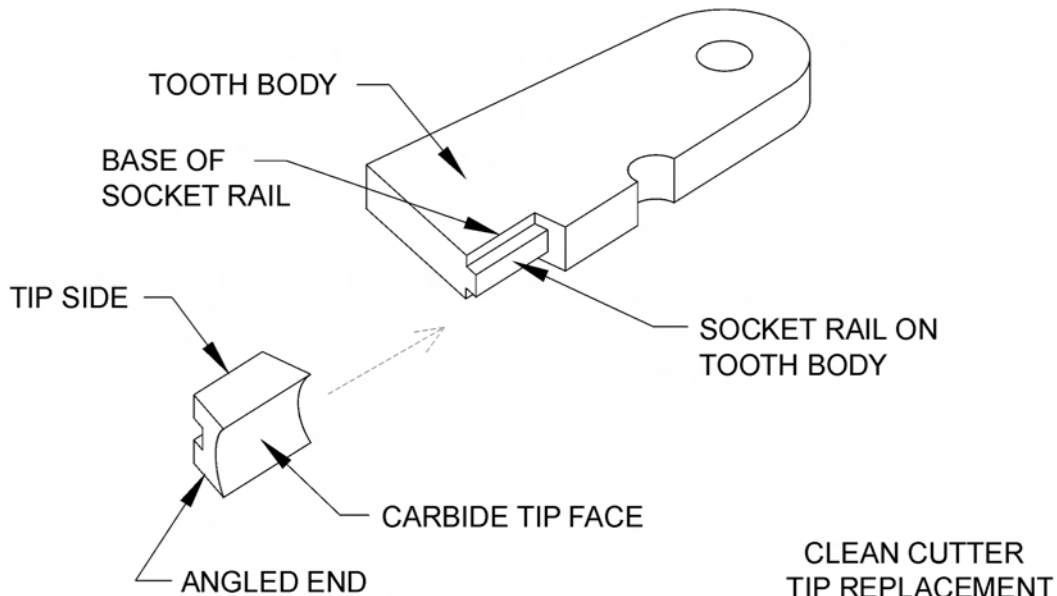

# NOTES



**FIRE SUPPRESSION SYSTEM  
SECTION**

# FIRE SUPPRESSION 3-POINT MOUNT

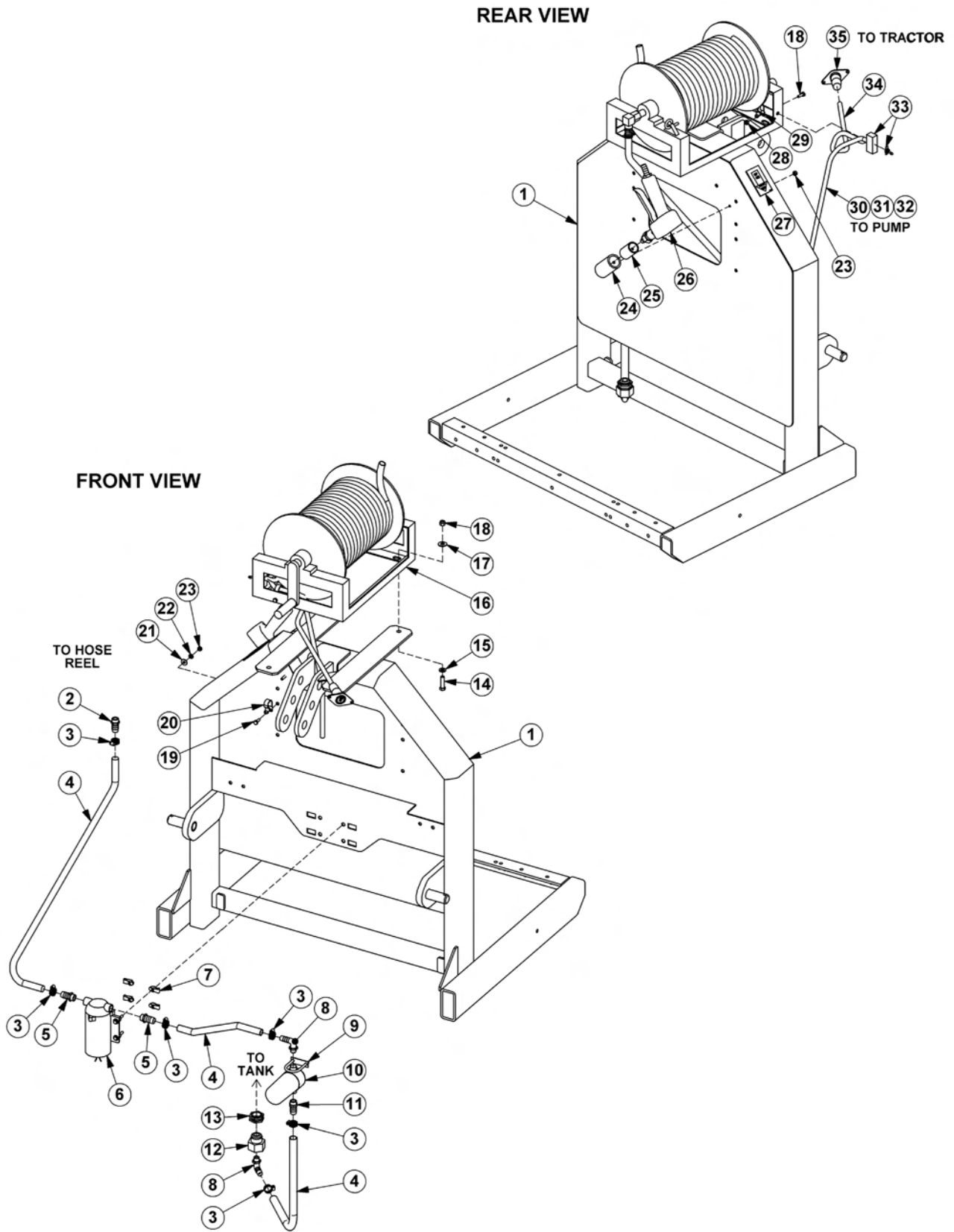

## FIRE SUPPRESSION 3-POINT MOUNT

Continued...

ITEM	PART NO.	QTY.	DESCRIPTION
1	06370137	1	MOUNT,3PNT,FIRE SYS
2	06503108	1	FITTING,1/2"BARB X 1/2"MP
3	35091	6	CLAMP,HOSE,#6
4	06520469	5	HOSE,1/2",BULK (FEET)
5	06503168	2	SWIVEL,1/2"STR,POLY
6	06520359	1	PUMP,LARGE
7	35176	4	U-NUT,1/4"
8	06520367	2	ELBOW,1/2"BARB X 1/2"MP,POLY
9	27329	1	U-BOLT,1/4"
10	06520361	1	FILTER
---	06520351	1	ELEMENT,FILTER
11	06520349	1	FITTING,BARB,HOSE
12	06503169	1	REDUCER,BUSHING (100 & 150 GALLON TANKS ONLY)
13	06520346	1	FITTING,BULKHEAD (50 GALLON TANKS ONLY)
14	21632	4	CAPSCREW,3/8" X 1-1/2",NC
15	21988	4	LOCKWASHER,3/8"
16	06520360	1	HOSE REEL
17	22016	4	FLATWASHER,3/8"
18	21627	4	NYLOCK NUT,3/8",NC
19	21529	2	CAPSCREW,1/4" X 3/4",NC
20	06510258	1	CLAMP,3/4"
21	22014	1	FLATWASHER,1/4"
22	21986	1	LOCKWASHER,1/4"
23	21525	2	HEX NUT,1/4",NC
24	06370121	1	HOLSTER
25	06430090	1	SLEEVE
26	06520366	1	GUN,FIRE SYS
27	6T3222	1	DECAL
28	21527	1	NYLOCK NUT,1/4",NC
29	06510257	1	CLAMP,3/8"
30	28055	5	WIRE,BLACK,14GA (FEET)
31	24200	5	WIRE,RED,14GA (FEET)
32	22802	5	WIRE WRAP (FEET)
33	PT3905A	1	SWITCH
34	06510256	4	CABLE,14GA,4WIRE (FEET)
35	06510255	1	PLUG,7PIN,TRCTR

COMMON LRS

# FIRE SUPPRESSION FRONT MOUNT

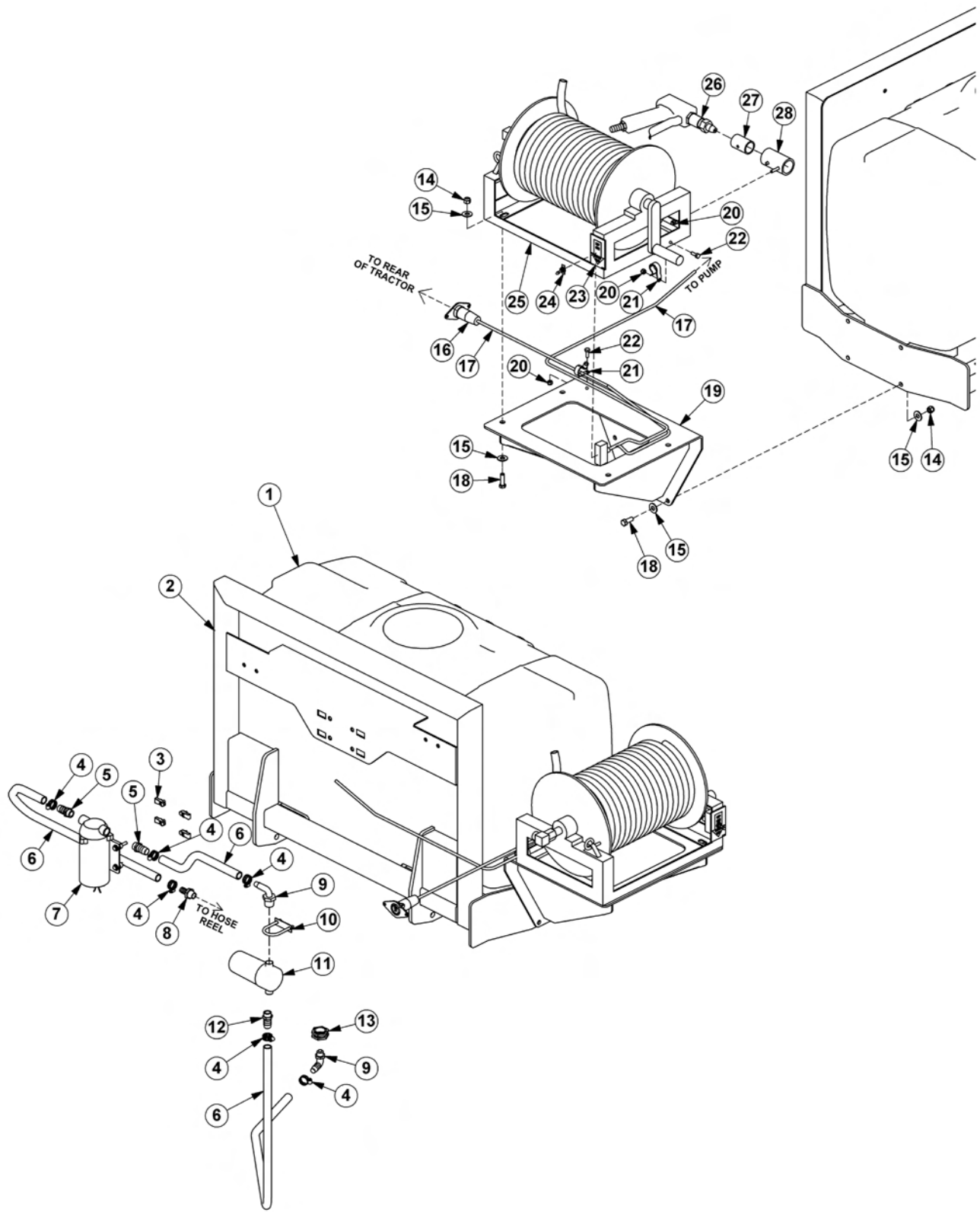

## FIRE SUPPRESSION FRONT MOUNT

Continued...

ITEM	PART NO.	QTY.	DESCRIPTION
1	06520342	1	TANK,50 GALLON
2	06370204	1	MNT,TANK,FRNT,50 GALLON
3	35176	4	U-NUT,1/4,3/4 TO CENTER
4	35091	6	CLAMP,HOSE,#6
5	06503168	2	SWIVEL,1/2 STR,POLY
6	06520469	8	HOSE,1/2,SPRAYER
7	06520359	1	PUMP,FIRE KIT
8	06503108	1	FITTING,1/2" BARB X 1/2"MP
9	06520367	2	ELBOW,1/2MPX1/2BARB,POLY
10	27329	1	U-BOLT,1/4X2X1
11	06520361	1	FILTER,FIRE KIT,RAILKUT
---	06520351	1	STRAINER,40 MESH
12	06520349	1	FITTING,BARB,HOSE,WETCUT
13	06520346	1	FITTING,BULKHEAD
14	21627	8	NYLOCK NUT,3/8 NC
15	22016	16	FLATWASHER,3/8,GR8
16	06510255	1	PLUG,7PIN,TRCTR
17	06510256	22	WIRE,14GA,4WIRE (FEET)
18	21631	8	CAPSCREW,3/8X1 1/4, NC,GR8
19	06370207	1	MNT,FIRE SUPPRESSION
20	21527	3	NYLOCK NUT,1/4 NC
21	06510257	2	CLAMP,3/8X1/4,INS
22	21529	2	CAPSCREW,1/4 X 3/4 NC
23	6T3222	1	DECAL,CONTROL,ON-OFF SWITCH
24	PT3905A	1	SWITCH,MOWER
25	06520360	1	HOSE REEL,FIRE KIT,RAILKUT
26	06520366	1	GUN,FIRE KIT,RAILKUT
27	06430090	1	SLEEVE,GUN,FIRE SYS
28	06370121	1	HOLSTER,FIRESYS,RAILKUT

COMMON LRS

# FIRE SUPPRESSION SYSTEM ELECTRICAL SCHEMATIC

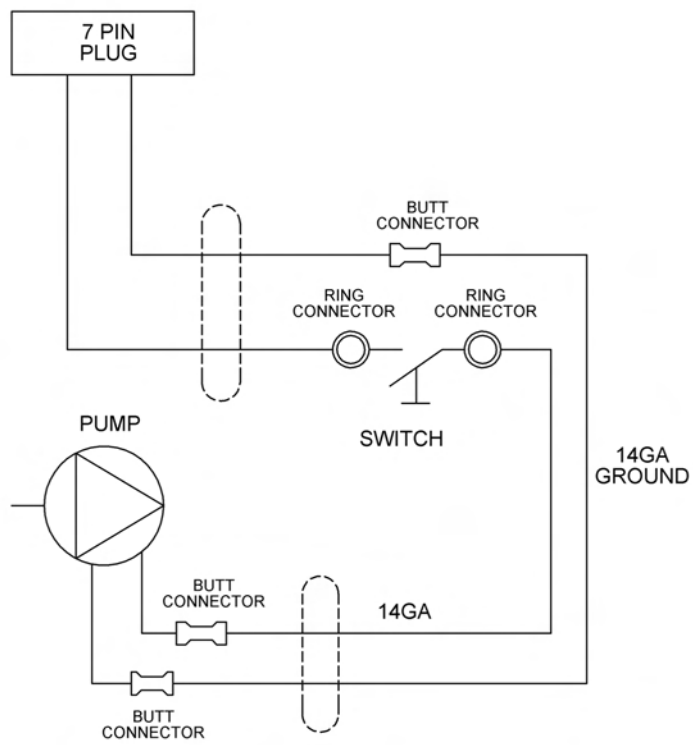

**WETCUT**

**WETCUT  
SECTION**

## WETCUT 50 GALLON TANK - 3PNT MOUNT

**INSTALL ITEM 2 INTO ITEM 1 FIRST**

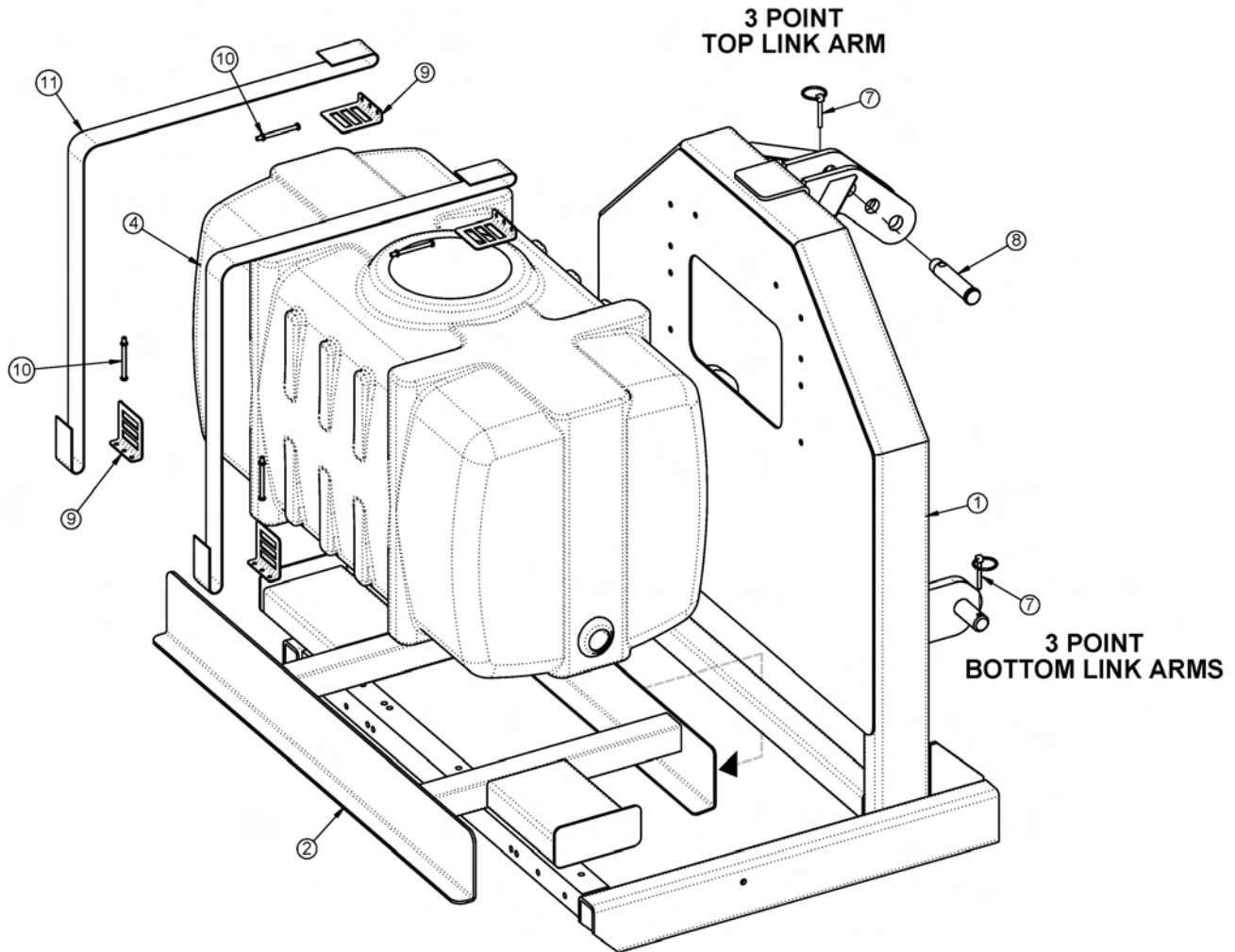

ITEM	PART NO.	QTY.	DESCRIPTION
1	06370128	1	MNT,3PNT,UNI
2	06370136	1	MNT,TANK,50GAL,WETCUT
4	06520342	1	TANK,50GA.,WETCUT
7	RD1032	3	PIN,LYNCH 1/4" X 2"
8	TB1036	1	PIN,SEC BOOM SWIV 1X4-11/16"
9	06520343	4	ANCHOR,STRAP,WETCUT
10	06520344	4	BOLT,STRAP,TANK,WETCUT
11	06520345	2	STRAP,TANK,WETCUT

COMMON LRS



## WETCUT 100 OR 150 GALLON TANK - 3PNT MOUNT

INSTALL ITEM 2 INTO ITEM 1 FIRST

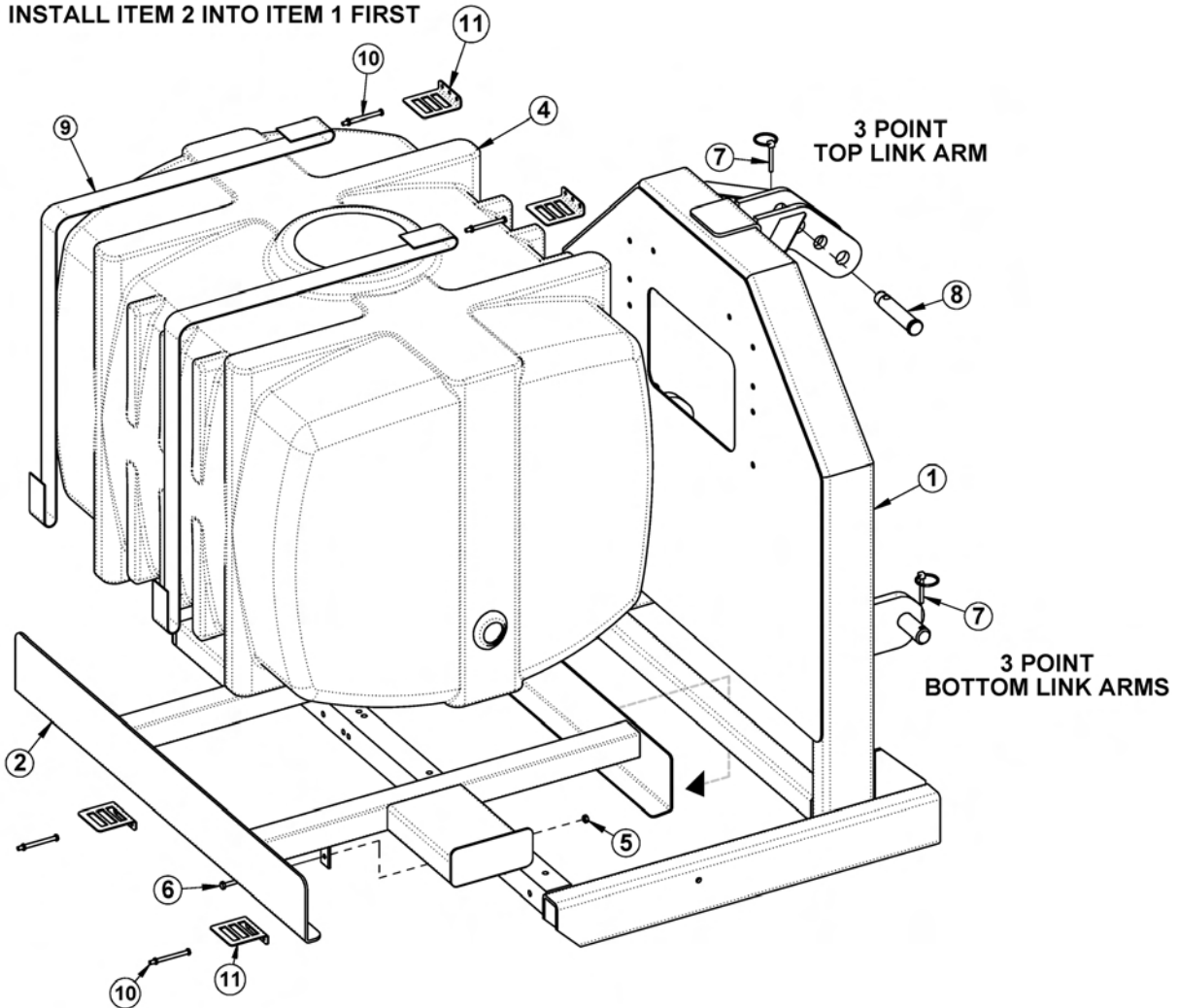

ITEM	PART NO.	QTY.	DESCRIPTION
1	06370128	1	MNT,3PNT,UNI
2	06370138	1	MNT,TANK,100GAL,WETCUT
-----	06370139	-	MNT,TANK,150GAL,WETCUT
4	06520372	1	TANK,100GA.,WETCUT
-----	06520373	-	TANK,150GA.,WETCUT
5	21527	2	HEX NUT,NYLOCK,1/4" NC
6	21530	2	CAPSCREW,1/4" X 1" NC
7	RD1032	3	PIN,LYNCH 1/4" X 2"
8	TB1036	1	PIN,SEC BOOM SWIV 1X4-11/16"
9	06520345	2	STRAP,TANK,WETCUT
10	06520344	4	BOLT,STRAP,TANK,WETCUT
11	06520343	4	ANCHOR,STRAP,WETCUT

COMMON LRS

# WETCUT 3PNT PLUMBING - 50IN MOWERS

1. NOTE ORIENTATION ON ITEM ⑨
2. ITEMS ⑰ ⑱ ⑲ ⑳ CUT FROM SUPPLIED 1/2" HOSE
3. ITEMS ㉑ ㉒ ㉓ CUT FROM SUPPLIED 3/8" HOSE

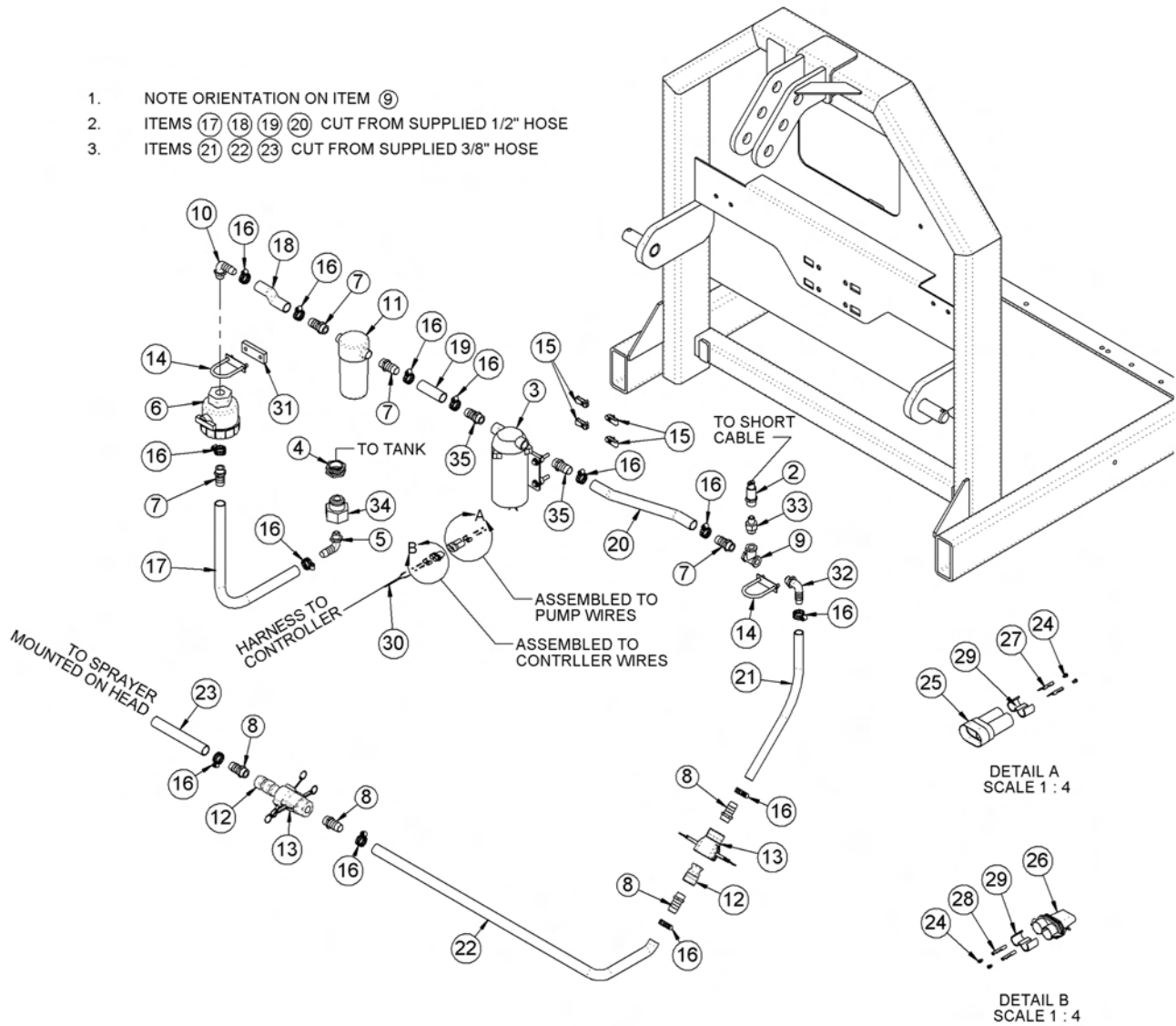

## WETCUT 3PNT PLUMBING - 50IN MOWERS

Continued...

ITEM	PART NO.	QTY.	DESCRIPTION
1	06370128	1	MNT,3PNT,UNI
2	06520336	1	CNTRLR,SENSOR,06520333
3	06520341	1	PUMP,WETCUT
4	06520346	1	FITTING,BULKHEAD,WETCUT (50 GALLON TANKS ONLY)
5	06520347	1	FITTING,ELBOW,WETCUT
6	06520348	1	VLV,BALL,WETCUT
7	06520349	4	FITTING,BARB,HOSE,WETCUT
8	06503173	4	FITTING,1/2MP X 3/8" BARB
9	06520353	1	FITTING,TEE,WETCUT
10	06520367	1	ELBOW,1/2" X 1/2" BARB,POLY
11	06520361	1	FILTER,FIRE KIT,RAILKUT
12	06520400	2	QUIK CPLR,MALE,1/2",WETCUT
13	06520401	2	QUIK CPLR,FEM,1/2",WETCUT
14	27329	2	U-BOLT,1/4" X 1" X 2"
15	35176	4	U-NUT,1/4",3/4" TO CENTER
16	35091	13	CLAMP, HOSE #6
17 - 20	06520469	5	1/2" HOSE (FEET)
21 - 23	06520316	-	3/8" HOSE (INCLUDED WITH SPRAYER)
24	06510051	4	SEAL,16-18GA,METPAK
25	06510052	1	CONN.,BODY,MALE,METRIPACK 150
26	06510053	1	CONN.,BODY,FEM,METRIPACK 150
27	06510054	2	TERMINAL,MALE,16/18GA.METPAK
28	06510055	2	TERMINAL,FEM,16/18GA.METPAK
29	06510056	2	TPA
30	06520337	1	INCLUDED WITH CONTROLLER
31	06401133	1	SPACER,Ø.31" X 1.75" X .38"
32	06503165	1	ELBOW,1/2"MP X 3/8" BARB
33	06520354	1	BUSHING,REDUCER,WETCUT
34	06503169	1	BUSHING,1"MP X 1/2"FP (100 & 150 GALLON TANKS ONLY)
35	06503176	2	FITTING,BARB,3/8"MP X 1/2" BARB

COMMON LRS

# WETCUT 3PNT PLUMBING - LARGE MOWERS

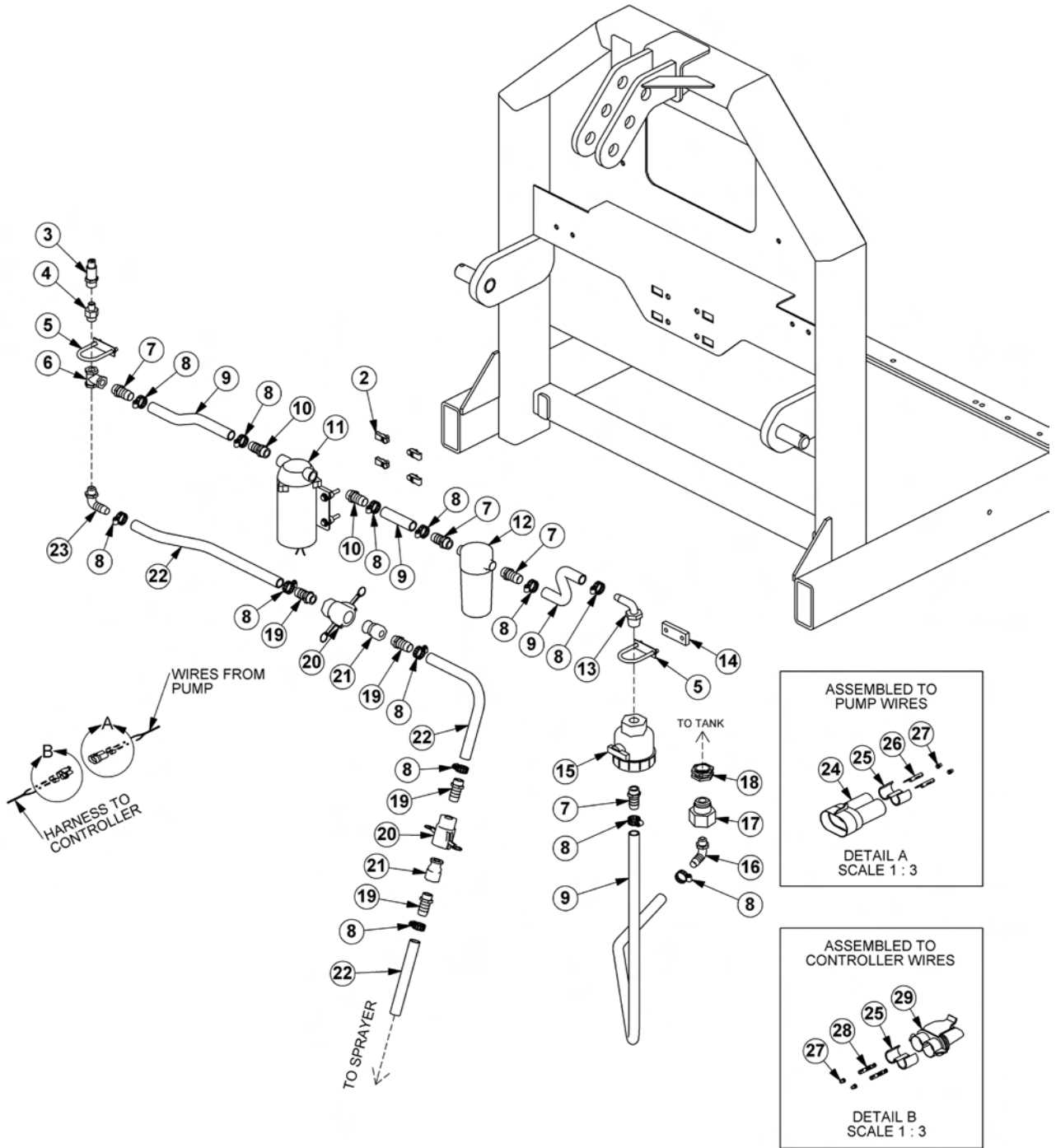

## WETCUT 3PNT PLUMBING - LARGE MOWERS

Continued...

ITEM	PART NO.	QTY.	DESCRIPTION
1	06370128	1	MNT,3PNT,UNI
2	35176	4	U-NUT,1/4,3/4 TO CENTER
3	06520336	1	CNTRLR,SENSOR,06520333
4	06520354	1	BUSHING,REDUCER,WETCUT
5	27329	2	U-BOLT,1/4" X 1" X 2"
6	06520353	1	FITTING,TEE,WETCUT
7	06520349	4	FITTING,BARB,HOSE,WETCUT
8	35091	13	CLAMP, HOSE #6
9	06520469	5	1/2" HOSE (FEET)
10	06503168	2	SWIVEL,1/2" STR
11	06520359	1	PUMP,LARGE
12	06520361	1	FILTER,FIRE KIT,RAILKUT
---	06520351	1	STRAINER,40MESH
13	06520367	1	ELBOW,1/2X1/2BARB,POLY
14	06401133	1	SPACER,Ø.31X1.75X.38
15	06520348	1	VLV,BALL,WETCUT
16	06520347	1	FITTING,ELBOW,WETCUT
17	06503169	1	BUSHING,1MPX1/2FP (100 & 150 GALLON TANKS ONLY)
18	06520346	1	FITTING,BULKHEAD,WETCUT (50 GALLON TANKS ONLY)
19	06503173	4	FITTING,BARB,1/2X3/8,WETCUT
20	06520401	2	QUIK CPLR,FEM,1/2,WETCUT
21	06520400	2	QUIK CPLR,MALE,1/2,WETCUT
22	06520316	-	3/8" HOSE (INCLUDED WITH SPRAYER)
23	06503165	1	ELBOW,1/2X3/8BARB,POLY
24	06510052	1	CONN.,BODY,MALE,METRIPACK 150
25	06510056	2	TPA
26	06510054	2	TERMINAL,MALE,16/18GA.METPAK
27	06510051	4	SEAL,16-18GA,METPAK
28	06510055	2	TERMINAL,FEM,16/18GA.METPAK
29	06510053	1	CONN.,BODY,FEM,METRIPACK 150

COMMON LRS

# WETCUT FRONT PLUMBING - 50IN MOWERS

1. NOTE ORIENTATION ON ITEM ⑨
2. ITEMS ⑰ ⑱ ⑲ ⑳ CUT FROM SUPPLIED 1/2" HOSE
3. ITEMS ㉑ ㉒ ㉓ CUT FROM SUPPLIED 3/8" HOSE

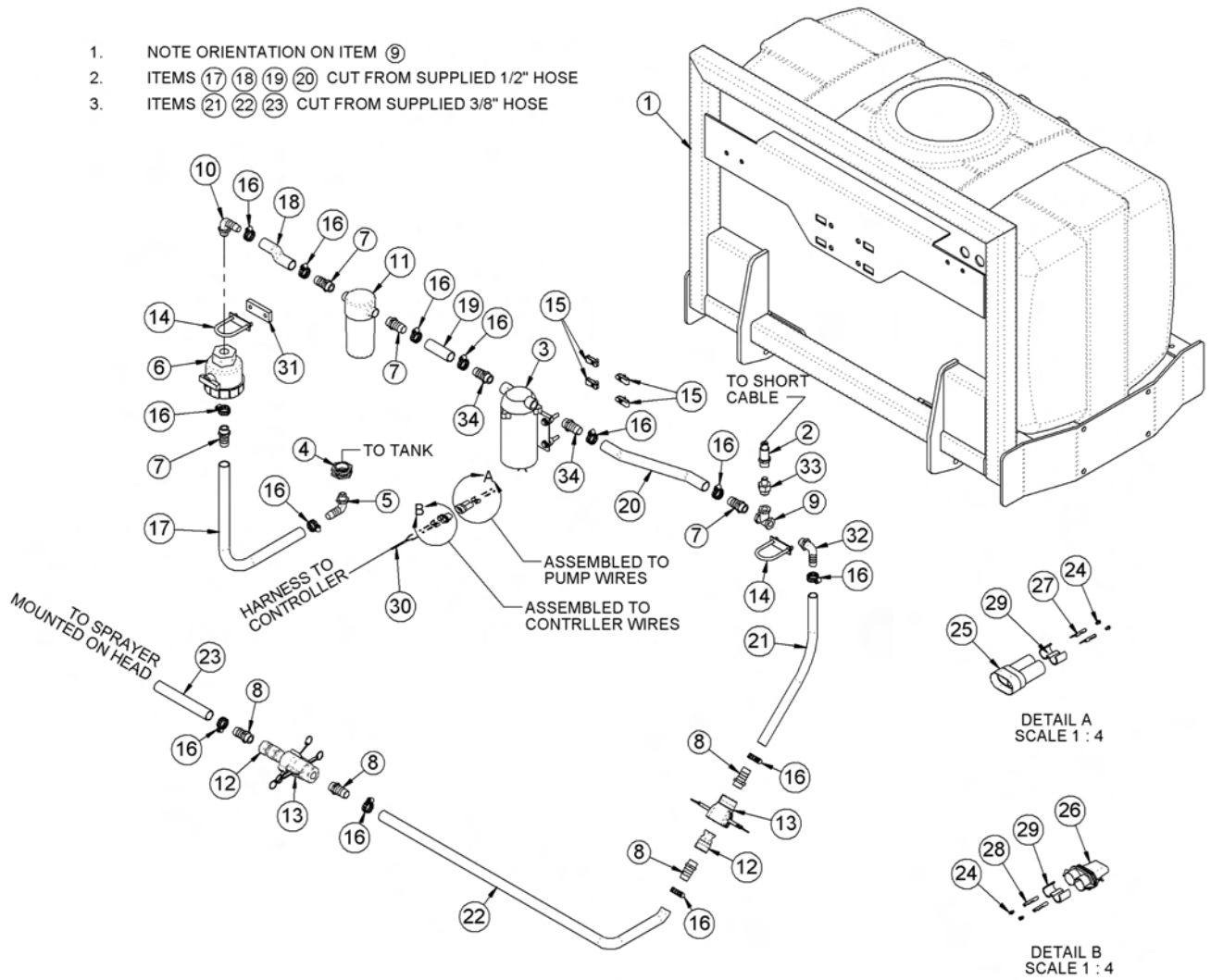

## WETCUT FRONT PLUMBING - 50IN MOWERS

Continued...

ITEM	PART NO.	QTY.	DESCRIPTION
1	06370204	1	MNT,FRONT,UNI
2	06520336	1	CNTRLR,SENSOR,06520333
3	06520341	1	PUMP,WETCUT
4	06520346	1	FITTING,BULKHEAD,WETCUT
5	06520347	1	FITTING,ELBOW,WETCUT
6	06520348	1	VLV,BALL,WETCUT
7	06520349	4	FITTING,BARB,HOSE,WETCUT
8	06503173	4	FITTING,1/2"MP X 3/8"BARB
9	06520353	1	FITTING,TEE,WETCUT
10	06520367	1	ELBOW,1/2"MP X 1/2"BARB,POLY
11	06520361	1	FILTER,FIRE KIT,RAILKUT
---	06520351	1	STRAINER,40MESH
12	06520400	2	QUIK CPLR,MALE,1/2",WETCUT
13	06520401	2	QUIK CPLR,FEM,1/2",WETCUT
14	27329	2	U-BOLT,1/4" X 1" X 2"
15	35176	4	U-NUT,1/4",3/4" TO CENTER
16	35091	13	CLAMP,HOSE #6
17 - 20	06520469	5	1/2" HOSE (FEET)
21 - 23	06520316	-	3/8" HOSE (INCLUDED WITH SPRAYER)
24	06510051	4	SEAL,16-18GA,METPAK
25	06510052	1	CONN.,BODY,MALE,METRIPACK 150
26	06510053	1	CONN.,BODY,FEM,METRIPACK 150
27	06510054	2	TERMINAL,MALE,16/18GA.METPAK
28	06510055	2	TERMINAL,FEM,16/18GA.METPAK
29	06510056	2	TPA
30	06520337	1	INCLUDED WITH CONTROLLER
31	06401133	1	SPACER,Ø.31" X 1.75" X .38"
32	06503165	1	ELBOW,1/2"MP X 3/8"BARB,POLY
33	06520354	1	BUSHING,REDUCER,WETCUT
34	06503176	2	FITTING,3/8"MP X 1/2"BARB

COMMON LRS

# WETCUT FRONT PLUMBING - LARGE MOWERS

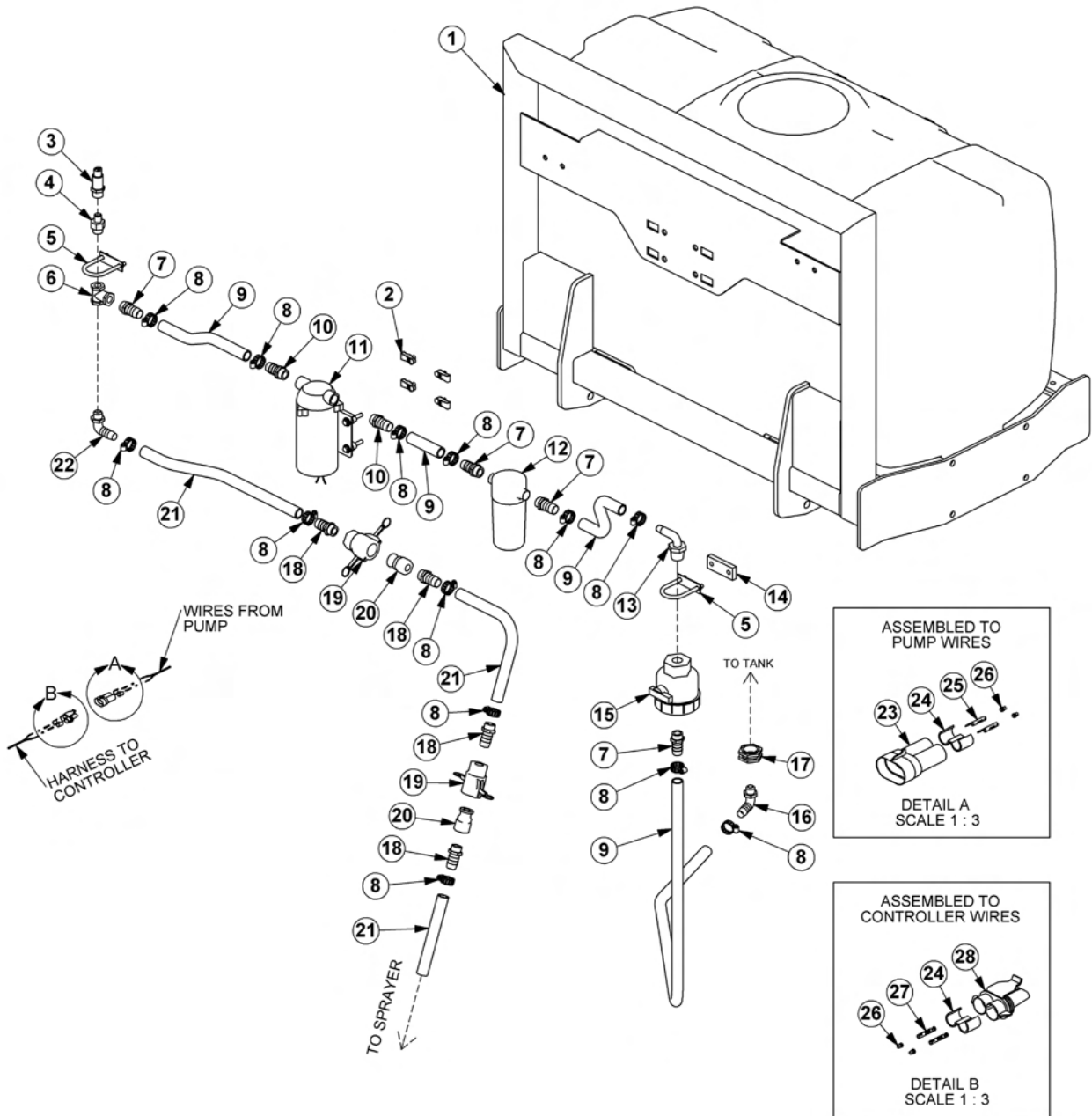



## WETCUT FRONT PLUMBING - LARGE MOWERS

Continued...

ITEM	PART NO.	QTY.	DESCRIPTION
1	06370204	1	MNT,FRONT,UNIV
2	35176	4	U-NUT,1/4,3/4 TO CENTER
3	06520336	1	CNTRLR,SENSOR,06520333
4	06520354	1	BUSHING,REDUCER,WETCUT
5	27329	2	U-BOLT,1/4" X 1" X 2"
6	06520353	1	FITTING,TEE,WETCUT
7	06520349	4	FITTING,BARB,HOSE,WETCUT
8	35091	13	CLAMP, HOSE #6
9	06520469	5	1/2" HOSE (FEET)
10	06503168	2	SWIVEL,1/2" STR
11	06520359	1	PUMP,LARGE
12	06520361	1	FILTER,FIRE KIT,RAILKUT
---	06520351	1	STRAINER,40MESH
13	06520367	1	ELBOW,1/2X1/2BARB,POLY
14	06401133	1	SPACER,Ø.31X1.75X.38
15	06520348	1	VLV,BALL,WETCUT
16	06520347	1	FITTING,ELBOW,WETCUT
17	06520346	1	FITTING,BULKHEAD,WETCUT
18	06503173	4	FITTING,BARB,1/2X3/8,WETCUT
19	06520401	2	QUIK CPLR,FEM,1/2,WETCUT
20	06520400	2	QUIK CPLR,MALE,1/2,WETCUT
21	06520316	-	3/8" HOSE (INCLUDED WITH SPRAYER)
22	06503165	1	ELBOW,1/2X3/8BARB,POLY
23	06510052	1	CONN.,BODY,MALE,METRIPACK 150
24	06510056	2	TPA
25	06510054	2	TERMINAL,MALE,16/18GA.METPAK
26	06510051	4	SEAL,16-18GA,METPAK
27	06510055	2	TERMINAL,FEM,16/18GA.METPAK
28	06510053	1	CONN.,BODY,FEM,METRIPACK 150

COMMON LRS

# WETCUT 50IN SPRAYER HEAD ASSEMBLY

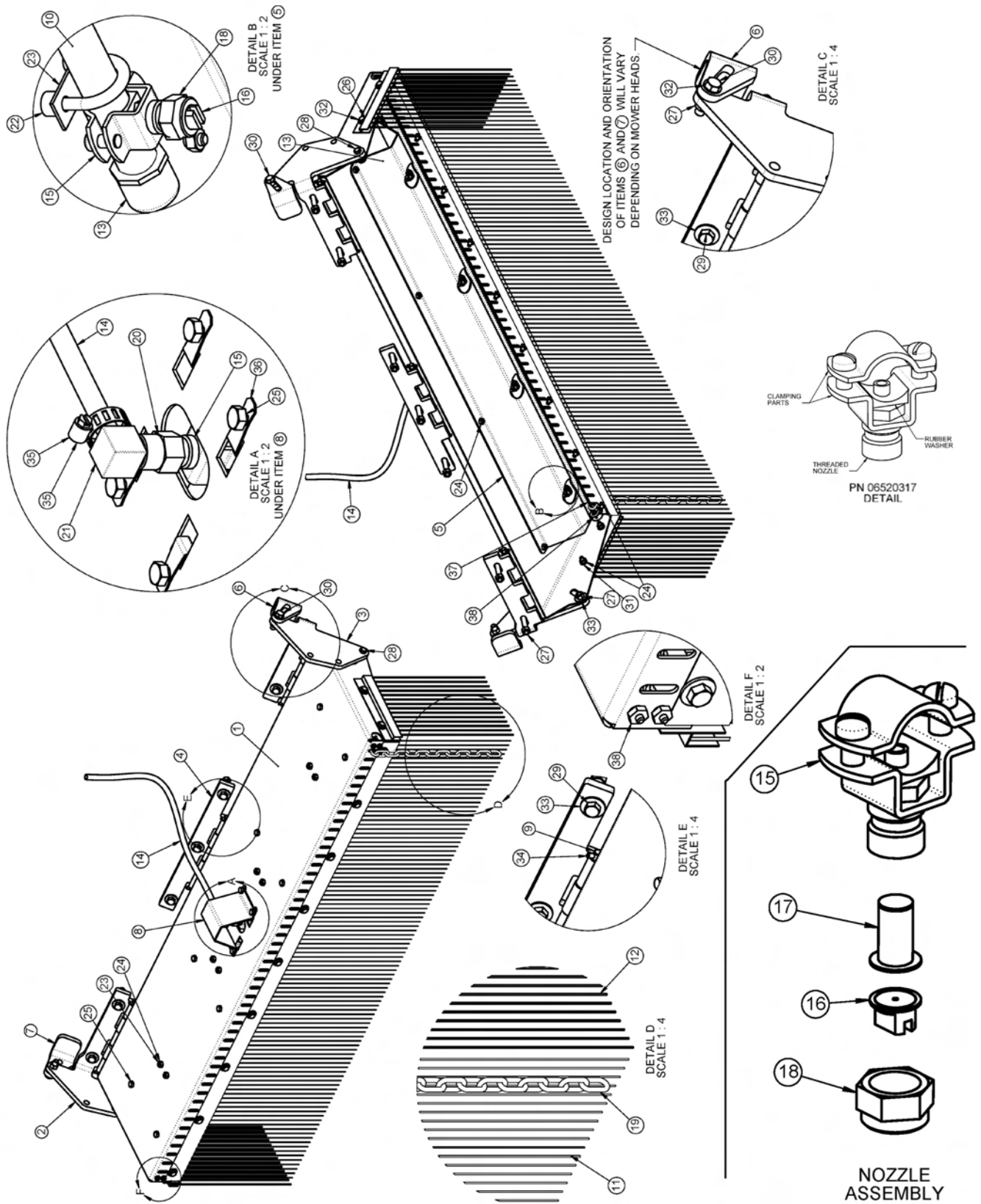

## WETCUT 50IN SPRAYER HEAD ASSEMBLY

Continued...

ITEM	PART NO.	QTY.	DESCRIPTION
1	06370105	1	HOOD,SPRAYER
2	06370106	1	HINGE,LH,SPRAYER
3	06370107	1	HINGE,RH,SPRAYER
4	06370108	1	HINGE,CNTR,SPRAYER
5	06410668	1	GUARD,SPRAYER,WETCUT
6	06410753	1	MNT,RH,WET CUT (FLAIL)
---	06410942	1	MNT,RH,WET CUT (ROTARY)
7	06410754	1	MNT,LH,WET CUT (FLAIL)
---	06410943	1	MNT,LH,WET CUT (ROTARY)
8	06410796	1	GUARD,HOSE,WETCUT
9	06420069	3	PIN,HINGE,WET CUT
10	06497003	1	TUBE,LG,SPRAYER
11	06499012	1	SKIRT,ANTI SPRAY,50
12	06499013	2	SKIRT,ANTI SPRAY,7
13	06520314	2	TUBE,CAP,SPRAYER
14	06520316	15	HOSE,SPRAYER (FEET)
15	06520317	5	NOZZLE,SPRAYER
16	06520319	4	TIP,NOZZLE,SPRAYER
17	06520320	4	FILTER,NOZZLE,SPRAYER
18	06520321	4	NUT,NOZZLE,SPRAYER
19	06520322	49	CHAIN,.18" X 1.31" X 13LINKS
20	06520381	1	ADAPTER,1/4"NPT,WETCUT
21	06520382	1	ELBOW,BARB,3/8" X 1/4"NPT
22	06520383	8	SPACER,.50"O.D. X .252"I.D. X .38",NYLON
23	32550	4	U-BOLT,1/4" X 1" X 1" X 1-3/4"
24	21527	29	HEX NUT,NYLOCK,1/4",NC
25	21528	12	CAPSCREW,1/4" X 1/2",NC
26	21529	13	CAPSCREW,1/4" X 3/4",NC
27	21625	11	HEX NUT,3/8",NC
28	21630	2	CAPSCREW,3/8" X 1",NC
29	21634	7	CAPSCREW,3/8" X 2",NC
30	21632	2	CAPSCREW,3/8" X 1-1/2",NC
31	21986	4	LOCKWASHER,1/4"
32	22014	15	FLATWASHER,1/4"
33	22016	9	FLATWASHER,3/8",GR8
34	34698	6	ROLL PIN, PLAIN, 3/16" X 7/8"
35	35091	1	CLAMP,HOSE #6
36	35176	4	U-NUT,1/4",3/4" TO CENTER
37	06520376	5	CABLE,3/16"
38	06537022	2	U-BOLT,CABLE,3/16"

COMMON LRS

# WETCUT 60IN SPRAYER HEAD ASSEMBLY

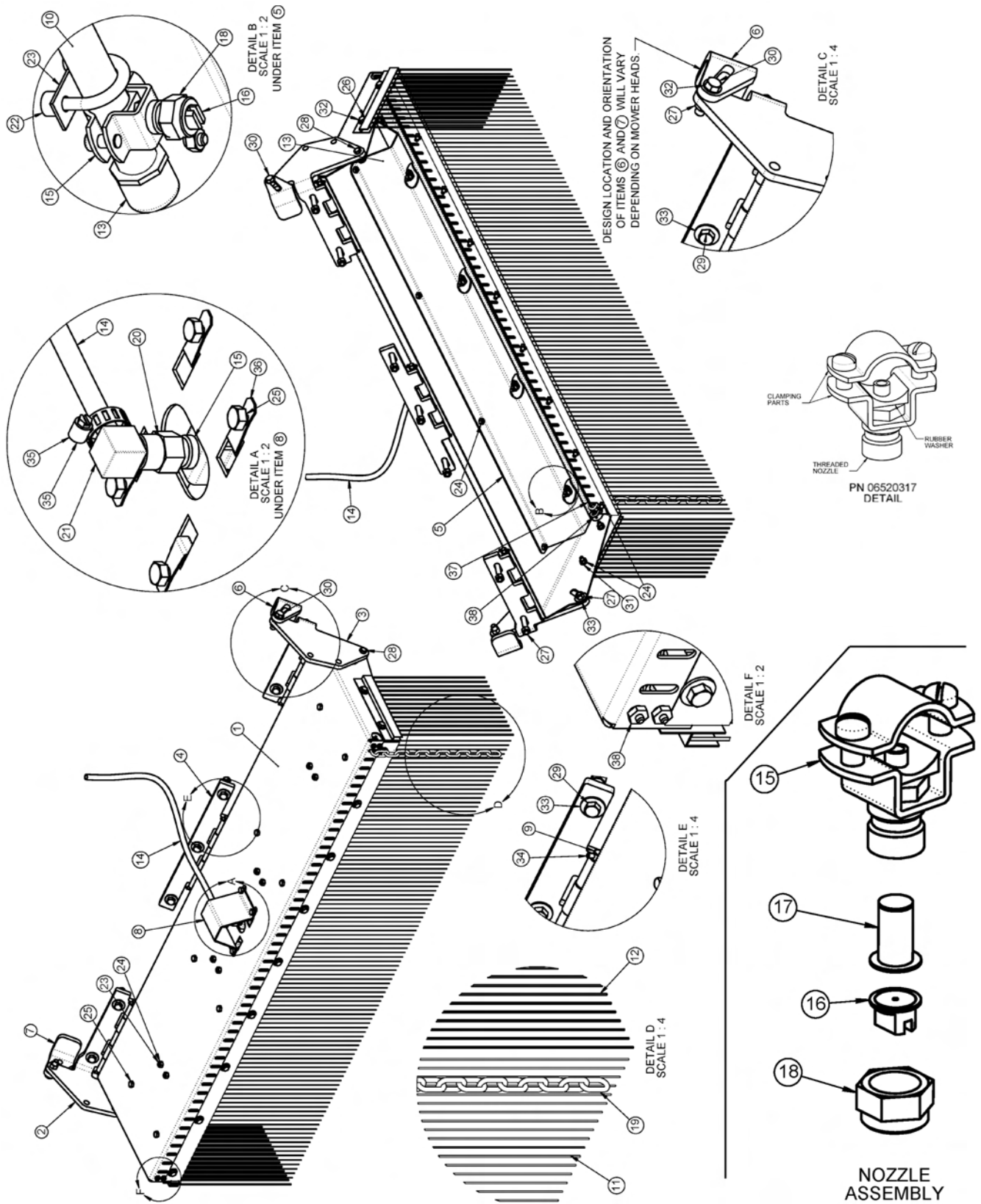

## WETCUT 60IN SPRAYER HEAD ASSEMBLY

Continued...

ITEM	PART NO.	QTY.	DESCRIPTION
1	06370210	1	HOOD,SPRAYER
2	06370106	1	HINGE,LH,SPRAYER
3	06370107	1	HINGE,RH,SPRAYER
4	06370108	1	HINGE,CNTR,SPRAYER
5	06411234	1	GUARD,SPRAYER,WETCUT
6	06410753	1	MNT,RH,WET CUT (FLAIL)
---	06410942	1	MNT,RH,WET CUT (ROTARY)
7	06410754	1	MNT,LH,WET CUT (FLAIL)
---	06410943	1	MNT,LH,WET CUT (ROTARY)
8	06410796	1	GUARD,HOSE,WETCUT
9	06420069	3	PIN,HINGE,WET CUT
10	06497009	1	TUBE,LG,SPRAYER
11	06499018	1	SKIRT,ANTI SPRAY,60
12	06499013	2	SKIRT,ANTI SPRAY,7
13	06520314	2	TUBE,CAP,SPRAYER
14	06520316	15	HOSE,SPRAYER (FEET)
15	06520317	6	NOZZLE,SPRAYER
16	06520319	5	TIP,NOZZLE,SPRAYER
17	06520320	5	FILTER,NOZZLE,SPRAYER
18	06520321	5	NUT,NOZZLE,SPRAYER
19	06520322	61	CHAIN,.18" X 1.31" X 13LINKS
20	06520381	1	ADAPTER,1/4"NPT,WETCUT
21	06520382	1	ELBOW,BARB,3/8" X 1/4"NPT
22	06520383	10	SPACER,.50"O.D. X .252" I.D. X .38",NYLON
23	32550	5	U-BOLT,1/4" X 1" X 1" X 1-3/4"
24	21527	33	HEX NUT,NYLOCK,1/4",NC
25	21528	15	CAPSCREW,1/4" X 1/2",NC
26	21529	13	CAPSCREW,1/4" X 3/4",NC
27	21625	13	HEX NUT,3/8",NC
28	21630	2	CAPSCREW,3/8" X 1",NC
29	21634	7	CAPSCREW,3/8" X 2",NC
30	21632	4	CAPSCREW,3/8" X 1-1/2",NC
31	21986	4	LOCKWASHER,1/4"
32	22014	33	FLATWASHER,1/4"
33	22016	11	FLATWASHER,3/8",GR8
34	34698	6	ROLL PIN, PLAIN, 3/16" X 7/8"
35	35091	1	CLAMP,HOSE #6
36	35176	4	U-NUT,1/4",3/4" TO CENTER
37	06520376	6	CABLE,3/16" (FEET)
38	06537022	2	U-BOLT,CABLE,3/16"

COMMON LRS

# WETCUT CABLES

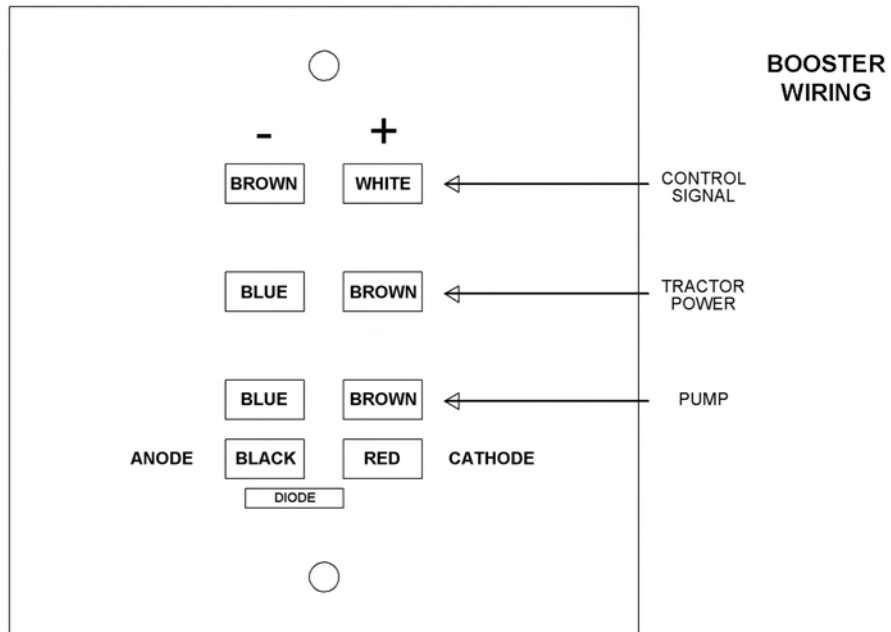
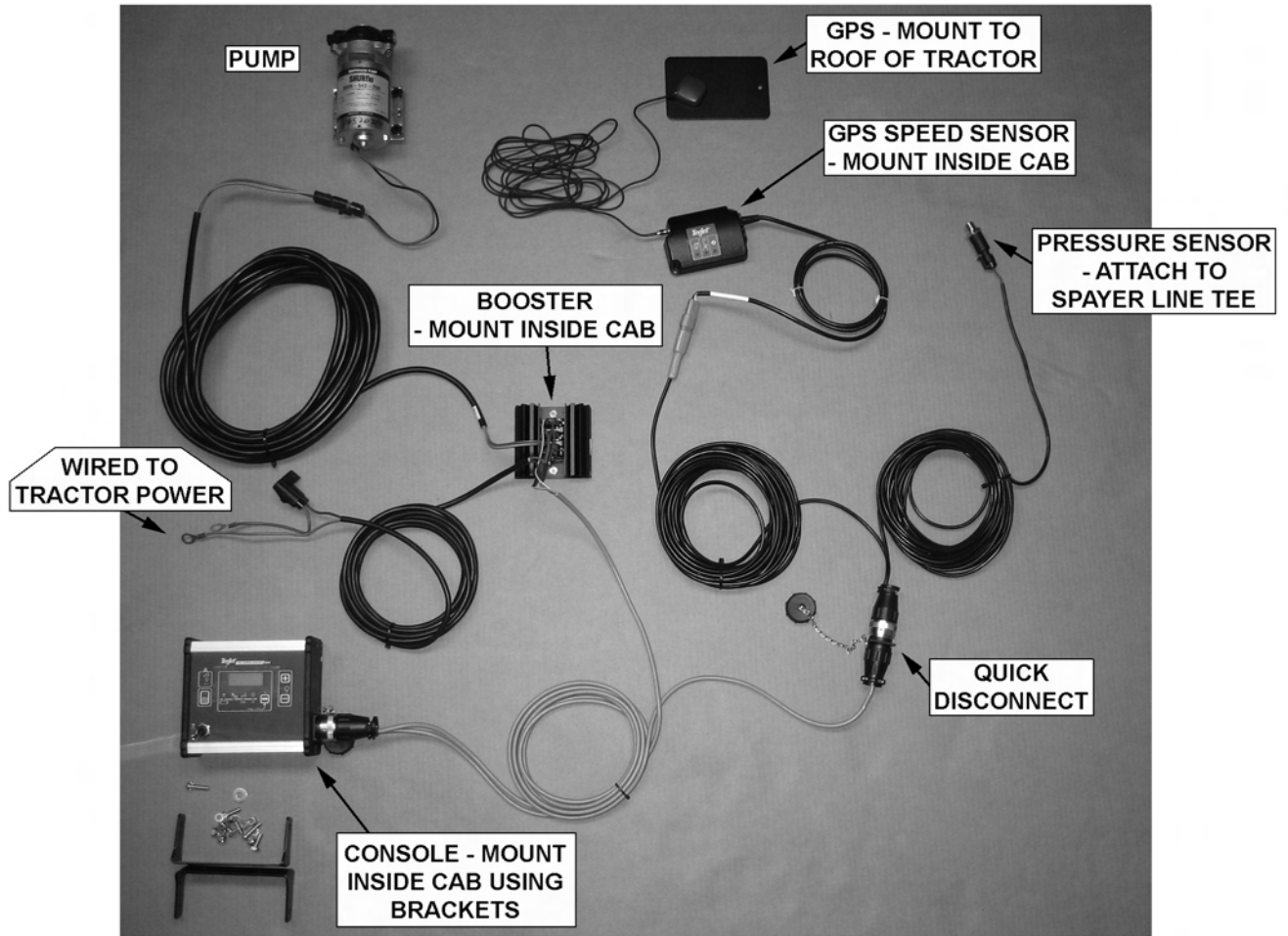

# **WARRANTY SECTION**





## WARRANTY INFORMATION

Tiger Corporation, 3301 N. Louise, Sioux Falls, South Dakota, warrants to the original Retail Customer, the new Tiger equipment is free of defects in material and workmanship. Any part of equipment that in Tiger's judgement, show evidence of such defects will be repaired or replaced without charge, provided that the failure of part(s) shall have occurred within twelve (12) months from the date of delivery of said equipment to the Retail Customer. Expendable components such as knives, oil, chain sprockets, skid shoes, knife mounting disks and the like are excluded but not limited to this warranty.

The Retail Customer must pay the transportation cost to and from the Tiger Dealer's service shop for warranty service. Warranty service will be performed by the Tiger Dealer from whom the equipment was purchased, during service shop regularly scheduled days and hours of operation.

All Tiger obligation under this warranty shall be terminated if the equipment is modified or altered in ways not approved in writing by Tiger, if repair parts other than genuine Tiger repair parts have been used, or if the equipment has been subject to misuse, neglect, accident, improper maintenance or improper operation.

Tiger Corporation reserves the right to make improvements in design or changes in specification at any time without incurring any obligation to owners of equipment previously sold.

No agent or person has authority to alter, add to or waive the above warranties which are agreed to be in the only warranties, representations or promises, expressed or implied, as to the quality or performance of the products covered and which do not include any implied warranty of merchantability or fitness. In no event will Tiger be liable for incidental or consequential damages or injuries, including, but not limited to, loss of profits, rental or substitute equipment or other commercial loss.

**THERE ARE NO WARRANTIES WHICH EXTEND  
BEYOND THOSE EXPRESSED HEREIN.**

It is the Purchasers obligation to sign the warranty registration form **AFTER** he / she has Read and Understands the Operation and Safety Instructions stated within this manual.

## **ONE LAST WORD**

This manual cannot possibly cover all of the potentially hazardous situations you will encounter. By being familiar with the safety rules, operating and maintenance instructions in this manual you can help prevent accidents. The objective of this manual is to help make you a better operator. Remember, **SAFETY IS YOU!**



1012

Your safety and the safety of those around you depends on **YOU**. Common sense should play a large role in the operation of this machine.

Since we at Tiger Corporation are constantly striving to improve our products, we reserve the right to change specifications or design at any time.

# TO THE OWNER / OPERATOR / DEALER



To keep your implement running efficiently and safely, read your manual thoroughly and follow these directions and the Safety Messages in this manual and on the machine. The table of contents clearly identifies each section where you can easily find the information you need.

The Occupational Safety and Health Act (OSHA 1928.51 subpart C) makes the following minimum requirements for tractor operators.

## **OWNER REQUIREMENTS:**

1. Provide a Roll-Over-Protective Structure that meets the requirements of this Standard; and
2. Provide Seatbelts that meet the requirements of this Standard and SAE J3C; and
3. Ensure that each employee uses such Seatbelt while the tractor is moving; and
4. Ensure that each employee tightens the Seatbelt sufficiently to confine the employee to the protected area provided by the ROPS.

## **OPERATOR REQUIREMENTS:**

1. Securely fasten seatbelt if the tractor has a ROPS.
2. Where possible, avoid operating the tractor near steep ditches, embankments, and holes.
3. Reduce speed when turning, crossing slopes, and on rough, slick, or muddy surfaces.
4. Stay off slopes too steep for safe operation.
5. Watch where you are going – especially at row ends, on roads, and around trees.
6. Do Not permit others to ride.
7. Operate the tractor smoothly – no jerky turns, starts, or stops.
8. Hitch only to the draw-bar and hitch points recommended by the tractor manufacturer.
9. When the tractor is stopped, set brakes securely and use park lock, if available



Printed in USA  
© Tiger Corporation