



New Holland TS6.110 T4B TWIN ROTARY

Current as of 4/11/2018



PARTS LISTING WITH MOUNTING AND OPERATING INSTRUCTIONS

Tiger Corporation
3301 N. Louise Ave.
Sioux Falls, SD 57107
1-800-843-6849
1-605-336-7900
www.tigermowers.com

06020030

TO THE OWNER / OPERATOR / DEALER

All implements with moving parts are potentially hazardous. There is no substitute for a cautious, safe-minded operator who recognizes the potential hazards and follows reasonable safety practices. The manufacturer has designed this implement to be used with all its safety equipment properly attached to minimize the chance of accidents.

BEFORE YOU START!! Read the safety messages on the implement and shown in this manual. Observe the rules of safety and use common sense!

READ AND UNDERSTAND THIS MANUAL! Non-English speaking operators will need to GET THE MANUAL TRANSLATED as needed!



DANGER

FAILING TO FOLLOW SAFETY MESSAGES AND OPERATING INSTRUCTIONS CAN CAUSE SERIOUS BODILY INJURY OR EVEN DEATH TO OPERATOR AND OTHERS IN THE AREA.

| | | | |
|-----------|---|--|---|
| <p>1.</p> | <p>2. NO RIDERS. NO CHILDREN OPERATORS.</p> | <p>3. USE SAFETY SHOES, HARD HAT, SAFETY GLASSES, SEAT BELTS, ROPS & OPS</p> | <p>4. BLOCK UP SECURELY BEFORE WORKING UNDER.</p> |
|-----------|---|--|---|

1. Study and understand Operator's Manuals, Safety Decals, and Instructional Decals for tractor and implement to prevent misuse, abuse, and accidents. Practice before operating in a confined area or near passersby.
 ● Learn how to stop engine suddenly in an emergency. Be alert for passersby and especially children

2. Allow no children on or near folding mower or tractor. Allow no riders on tractor or implement. Falling off may cause serious injury or death from being run over by tractor or mower or contact with rotating blades.

3. Operate only with tractor having Roll-Over Protective Structure (ROPS) and with seat belt securely fastened to prevent injury and possible death from falling off or tractor overturn.
 ● Personal Protective Equipment such as Hard Hat, Safety Glasses, Safety Shoes, & Ear Plugs are recommended.

4. Block up or support raised machine and all lifted components securely before putting hands or feet under or working underneath any lifted component to prevent crushing injury or death from sudden dropping or inadvertent operation of controls. Make certain area is clear before lowering or folding

5. Before transporting, put Lift Lever in detent or full-lift position. Install Transport Safety Devices securely on folding mowers. Put Booms securely in Transport Rest.
 ● Folding and Boom Mowers have raised center of gravity. Slow down when turning and on hillsides.

6. Make certain that SMV sign, warning lights, and reflectors are clearly visible. Follow local traffic codes.

7. Never operate with Cutting Head or Folding Section raised if passersby, bystanders, or traffic are in the area to reduce possibility of injury or death from objects thrown by Blades under Guards or mower structure.

8. Before dismounting, secure implement in transport position or lower to ground.
 ● Put tractor in park or set brake, disengage PTO, stop engine, remove key, and wait until noise of rotation has ceased to prevent crushing by entanglement in rotating parts which could cause injury or death.
 ● Never mount or dismount a moving vehicle. Crushing from runover may cause serious injury or death.

| | | | |
|--------------------------------------|--|--|--|
| <p>5. TRANSPORT SAFELY, LOCK UP.</p> | <p>6. USE SMV, LIGHTS, & REFLECTORS.</p> | <p>7. DO NOT OPERATE WITH CUTTER OR WING RAISED.</p> | <p>8. DO NOT MOUNT OR DISMOUNT WHILE MOVING.</p> |
|--------------------------------------|--|--|--|

Warranty Information: Read and understand the complete Warranty Statement found in this manual. Fill out the Warranty Registration form in full and return it within 90 days. Make certain the Serial Number of the machine is recorded on the Warranty Card, and form that you retain.

FORWARD

This manual contains information about many features of the Tiger mowing and roadside maintenance equipment. Some of these include: Safety precautions, Assembly instructions, Operations, Maintenance and Parts. This manual will also assist you in the proper break-in, daily care, and troubleshooting of your new mower.

We recommend that you read carefully the entire manual before operating the unit. Also, time spent in becoming fully acquainted with its performance features, adjustments, and maintenance schedules will be repaid in a long and satisfactory life of the equipment.

Troubleshooting - Please, before you call, help us to help you!

Please look at the equipment to observe what is happening, then:

- Classify the problem
 - Hydraulic, electrical or mechanical - Read the trouble shooting section
 - Tractor or Truck chassis - Contact vehicle dealer

- If unable to correct the problem yourself, contact your local Tiger Dealer after gathering:
 - Machine model _____
 - Serial number _____
 - Dealer name _____
 - Detailed information about the problem including results of troubleshooting

Attention Owner / Operator / Dealer: It is your obligation to read, and understand, the warranty information section located at the back of this manual denoting that the purchaser understands the safety issues relating to this machine and has received and will read a copy of this manual.

If at any time, you have a service problem with your Tiger mower, Contact your local dealer for service and parts needed.

MANUFACTURED BY:

Tiger Corporation

3301 N. Louise Ave.

Sioux Falls, SD 57107

1-800-843-6849

1-605-336-7900

www.tiger-mowers.com

DISTRIBUTED BY:

1- _____ - _____ - _____

1- _____ - _____ - _____

TABLE OF CONTENTS

| | |
|----------------------------------|---|
| SAFETY SECTION_____ | 1 |
| ASSEMBLY / MOUNTING SECTION_____ | 2 |
| OPERATION SECTION_____ | 3 |
| MAINTENANCE SECTION_____ | 4 |
| PARTS SECTION_____ | 5 |
| COMMON PARTS SECTION_____ | 6 |
| WARRANTY INFORMATION_____ | 7 |



1012

This symbol means:

CAUTION – YOUR SAFETY IS AT RISK!

When you see this symbol, read and follow the associated instructions carefully or personal injury or damage may result.

Tiger is a registered trademark.



SAFETY SECTION

Safety Section 1-1

SAFETY

GENERAL SAFETY INSTRUCTIONS AND PRACTICES

A careful operator is the best operator. Safety is of primary importance to the manufacturer and should be to the owner/operator. Most accidents can be avoided by being aware of your equipment, your surroundings, and observing certain precautions. The first section of this manual includes a list of Safety Messages that, if followed, will help protect the operator and bystanders from injury or death. Read and understand these Safety Messages before assembling, operating or servicing this Implement. This equipment should only be operated by those persons who have read the manual, who are responsible and trained, and who know how to do so responsibly.



The Safety Alert Symbol combined with a Signal Word, as seen below, is used throughout this manual and on decals which are attached to the equipment. The Safety Alert Symbol means: "ATTENTION! BECOME ALERT! YOUR SAFETY IS INVOLVED!" The Symbol and Signal Word are intended to warn the owner/operator of impending hazards and the degree of possible injury faced when operating this equipment.

Practice all usual and customary safe working precautions and above all--- remember safety is up to YOU. Only YOU can prevent serious injury or death from unsafe practices.



Indicates an imminently hazardous situation that, if not avoided, WILL result in DEATH OR VERY SERIOUS INJURY.



Indicates an imminently hazardous situation that, if not avoided, COULD result in DEATH OR SERIOUS INJURY.



Indicates an imminently hazardous situation that, if not avoided, MAY result in MINOR INJURY.



Identifies special instructions or procedures that, if not strictly observed, could result in damage to, or destruction of the machine, attachments or the environment.

NOTE: *Identifies points of particular interest for more efficient and convenient operation or repair.*

READ, UNDERSTAND, and FOLLOW the following Safety Messages. Serious injury or death may occur unless care is taken to follow the warnings and instructions stated in this Manual and in the Safety Messages on the implement. Always follow the instruction in this manual and use good common sense to avoid hazards.



NOTE: *If you want a translation of this safety section in one of the following Languages, please contact: Translations at 1502 E. Walnut Street Seguin, TX 78155; Fax: (830) 372-9529; Safety Section Translations are available in Spanish, Portuguese, French, German, Russian. PN GS01*

SAFETY

Operator Safety

| | | | | |
|---|---|---|--|---|
|  |  |  |  |  |
| Read and understand Operator's Manual | Always wear Safety Glasses | Wear Hard Hat Safety Shoes | Never use Drugs or Alcohol when operating equipment | Wear Safety Vest when operating on or near roads |

WARNING

TO AVOID SERIOUS INJURY OR DEATH DO THE FOLLOWING:

- **READ, UNDERSTAND** and **FOLLOW** Operator's Manual instructions, Warnings and Safety Messages.
- **WEAR SAFETY GLASSES**, safety shoes, hard hat, hearing protection and gloves when operating or repairing equipment
- **WEAR** appropriate breathing respirator when operating in dusty conditions to avoid respiratory diseases.
- **DO NOT WEAR** loose clothing or jewelry to avoid rotating parts entanglement injury.
- **DO NOT USE DRUGS** or **ALCOHOL** before or while operating equipment.
- **DO NOT ALLOW** anyone to operate equipment under the influence of drug or alcohol.
- **CONSULT** medical professional for medication impairment side effects.
- **STAY CLEAR** of hot surfaces such as Mufflers, hydraulic pumps, valves and tanks.
- **STAY ALERT**, prolonged operation can cause fatigue, **STOP** and **REST**.

GENERAL OPERATING SAFETY

VISIBILITY CONDITIONS WHEN MOWING:

- **OPERATE IN DAYLIGHT** or with lights that gives at least 100 yards clear visibility.
- **BE ABLE TO SEE** and identify passersby, steep slopes, ditches, drop-offs, overhead obstructions, power lines, debris and foreign objects.
- Avoid backing up while mowing, vision may be limited, severe damage or injury can occur.
- **DO NOT** run tractor in enclosed building without adequate exhaust ventilation.

GROUND SPEED WHEN MOWING:

- **NORMAL SPEED** range is between 1 to 2 mph(1-3 kph).
- **ADJUST MOWING SPEED** for terrain conditions and grass type, density and cut height.
- **REDUCE MOWING SPEED** when near steep slopes, ditches, drop-offs, overhead obstructions, power lines and to avoid debris and foreign objects.

TRACTOR and MOWER

- **DO NOT** operate the tractor or mower unless the equipment is maintained and operating properly.
- **DISCONTINUE OPERATION** if tractor or mower electrical and hydraulic controls do no function properly.
- **DISCONTINUE OPERATION** of the tractor if the braking or steering systems do not function properly.
- **DO NOT** operate the tractor or mower if there are any hydraulic leaks.

INSECT INFESTATION

- **DO NOT** operate in areas where bees or insects may attack unless you **WEAR PROTECTIVE CLOTHING** or use enclosed tractor cab.

PTO SPEED:





- **DO NOT EXCEED IMPLEMENT RATED PTO SPEED**
- **AVOID** exceeding rated PTO speeds that may result in broken drivelines or blade failures.

SAFETY SIGNS:

- **REPLACE** missing, damaged or unreadable safety signs immediately. *PN OSBM-01*

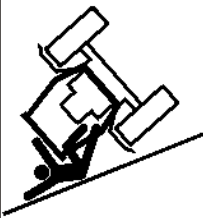
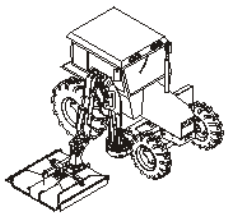
SAFETY

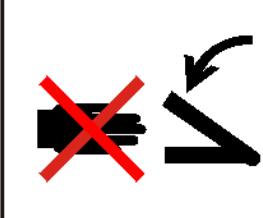
CRUSHING HAZARDS

| | | | | |
|---|---|---|--|---|
|  |  |  |  |  |
| Crushing injury from roll over | Use Cab Tractor With Boom Mowers | Always wear seatbelt | Pinch Point Hazard Keep Hands and body parts clear of pinch points | Crushing injury from boom or mower head falling |



TO AVOID SERIOUS INJURY OR DEATH FROM FALLING OFF TRACTOR, EQUIPMENT RUN OVER, ROLLOVER AND CRUSHING BY FALLING WING OR IMPLEMENT:

- USE ROPS and SEAT BELT equipped tractors for mowing operations.
- KEEP ROPS lock in up position.
- ALWAYS BUCKLE UP seat belt when operating tractor and equipment.
- ONLY OPERATE tractor and equipment while seated in tractor seat.

WHEN RAISING BOOM MOWER:

- Raise or lower **ONLY WHILE SEATED** in tractor seat with seat belt buckled.
- KEEP BYSTANDERS CLEAR of area TO AVOID crushing.
- KEEP sufficient clearance around implement and wings TO AVOID contacting buildings or overhead power lines.

LIFTED Equipment can fall from mechanical or hydraulic failure or inadvertent Control Lever movement.



TO AVOID EQUIPMENT FALLING while working near or under lifted boom, components and Mower Head:

- SECURELY SUPPORT or block up raised equipment, wings and components.
- BLOCK UP and securely support equipment before putting hands, feet or body under raised equipment or lifted components.
- KEEP BYSTANDERS CLEAR of raised boom or mower head until securely blocked up.

WHEN PARKING Implement and Tractor:

- LOWER Mower Head to the ground or BLOCK lifted parts before leaving equipment.
- NEVER leave implement unattended in a raised position.







TO AVOID CHILDREN FALLING OFF OR BEING CRUSHED BY EQUIPMENT:

- NEVER ALLOW children to play on or around Tractor or Implement.
- DO NOT operate without operator CAB or OVERHEAD protection. Falling limbs and debris can cause injuries. *PN CHBM-01*

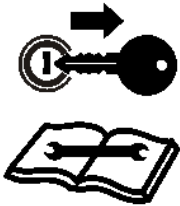
SAFETY

CONNECTING OR DISCONNECTING IMPLEMENT SAFETY

| | | | |
|---|---|---|---|
|  |  |  |  |
| <p>Stop Tractor Remove Key Read Manual</p> | <p>Crushing Hazard Do Not get under boom when connecting mower head to boom</p> | <p>Stability Hazard Ensure 20% of tractor weight is on front wheels</p> | <p>Stability Hazard Ensure 1500lbs down force on left tire with boom extended</p> |



TO AVOID SERIOUS INJURY OR DEATH FROM BEING CRUSHED BY TRACTOR OR IMPLEMENT:

WHEN connecting mower head to the boom:

- **KEEP BYSTANDERS AWAY** from tractor and mower.
- Ensure there is enough room to lift and swing the boom with out hitting objects

BEFORE connecting and disconnecting the mower head or boom:

- **STOP TRACTOR ENGINE**, place transmission into park, engage parking brake and remove key.

WHEN connecting and disconnecting the mower head or boom:

- **DO NOT** crawl or walk under raised mower head or boom. (*Refer to Instructions in Operation Section*)

WHEN CONNECTING IMPLEMENT DRIVELINE:(If equipped)

TO AVOID implement driveline coming loose during operation:

- **LUBRICATE** yoke spring locking collar to ensure it freely slides on PTO shaft.
- **SECURELY** seat yoke locking balls in PTO shaft groove.
- **PUSH** and **PULL DRIVELINE** on both the tractor and implement **PTO SHAFTS** to ensure it is **SECURELY ATTACHED**.

TO AVOID broken driveline during operations:

- **CHECK** driveline for proper length between PTO shaft and implement gearbox shaft. (*Refer to Instructions in Operation Section*)
- Drivelines too short can pull apart or disengage.
- Drivelines too long can bottom out.
- Bottoming driveline telescoping assembly will stop sliding and become solid.
- Driveline bottoming can push through support bearings and break off PTO shaft.





CONTACT DEALER if implement driveline does not match Tractor PTO shaft:

- **DO NOT USE PTO ADAPTER.**
Using a PTO adapter can cause:
 - Excessive vibration, thrown objects, blade and implement failures by doubling operating speed.
 - Increased working length exposing unshielded driveline areas and entanglement hazards. *PN CDBM-01*

SAFETY

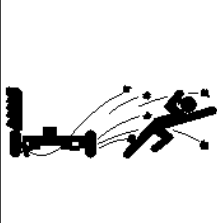
SAFETY

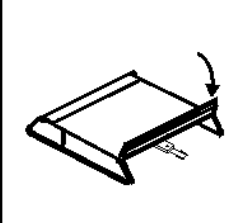
THROWN OBJECTS HAZARDS

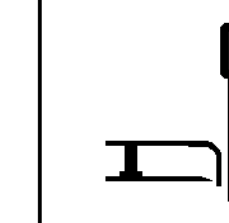
| | | | | |
|---|---|---|--|---|
|  |  |  |  |  |
| Mower Thrown Objects Hazard | Raised Mower Thrown Objects | Keep mower door closed when traffic comes within 300 feet | Inspect Area remove foreign objects | Do not let blades contact solid objects |



ROTARY MOWERS CAN THROW OBJECTS 300 FEET OR MORE UNDER ADVERSE CONDITIONS.

TO AVOID SERIOUS INJURY OR DEATH TO OPERATOR OR BYSTANDERS FROM THROWN OBJECTS:

- KEEP bystanders 300 feet away

STOP MOWING IF PASSERSBY ARE WITHIN 300 FEET UNLESS:

- **ALL THROWN OBJECT SHIELDING** including, Front and Rear Deflectors, Chains Guards, Steel Guards, Bands, Side Skirts and Skid Shoes in place and in good condition when mowing.
- Mower is close and parallel to ground without exposing blades.
- **MOWING AREA** has been inspected and foreign materials and debris have been removed.
- **DO NOT** shred or mow loose or previously cut material if **BYSTANDERS** are within 300 feet.
- **PASSERSBY** are inside enclosed vehicle.

INSPECT AREA FOR POTENTIAL THROWN OBJECTS BEFORE MOWING:

- **REMOVE** debris, rocks, wire, cable, metal objects and other foreign material from area.
Wire, cable, rope, chains and metal objects can be thrown or swing outside deck with great velocity:
 1. **MARK** objects that cannot removed.
 2. **AVOID** these objects when mowing.

HIGH GRASS and WEED AREA INSPECTION:

- **INSPECT** for and **REMOVE** any hidden large debris.
- **MOW** at Intermediate height
- **INSPECT** and remove remaining debris
- **MOW** at final height.

MOWER THROWN OBJECT SHIELDING:



- **KEEP** all thrown object shielding including, Front and Rear Deflectors, Chains Guards, Steel Guards, Bands, Side Skirts and Skid Shoes in place and in good condition when mowing.
- **DO NOT OPERATE** with any thrown object shielding missing, damaged or removed.

RIGHT OF WAY (Highway) MOWING

- Stop mowing if any bystander comes within 300 feet of the mower.
- No shielding is 100% effective in preventing thrown objects. To Reduce Possibility of Injury:
 1. **MAINTAIN MOWER SHIELDING**, side skirts, skid shoes, and blades in good operational condition,
 2. **RAISE CUTTING HEIGHT** to **6 INCHES** minimum,
 3. **INSPECT AREA** thoroughly before mowing to **REMOVE** potential **THROWN OBJECT HAZARDS**,
 4. **NEVER ALLOW BLADES** to **CONTACT SOLID OBJECTS** like wire, rocks, post, curbs, guardrails, or ground while mowing. *PN TOBM-01*

SAFETY

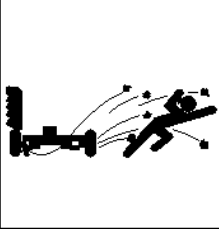
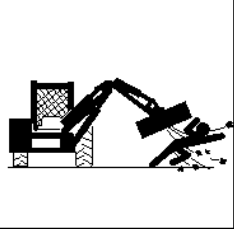
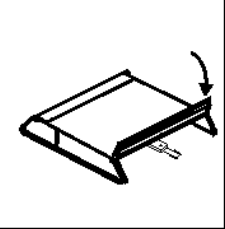
THROWN OBJECTS HAZARDS (Continued)

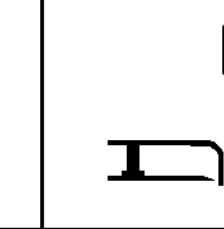
| | | | | |
|---|---|---|--|---|
|  |  |  |  |  |
| Mower Thrown Objects Hazard | Raised Mower Thrown Objects | Keep mower door closed when traffic comes within 300 feet | Inspect Area remove foreign objects | Do not let blades contact solid objects |

MOWER OPERATION:

- **DO NOT** exceed mower's rated Cutting Capacity or cut non-vegetative material.
- **USE ENCLOSED TRACTOR CABS** when two or more mowers are operating in mowing area.
- Do Not mow in areas where bees or insects may attack unless you **WEAR PROTECTIVE CLOTHING** or use enclosed tractor cab.
- **ADJUST** mower head close and parallel to ground without exposing blades.
- **ADJUST** cutting **HEIGHT** to **AVOID BLADE CONTACT** with solid objects like wire, rocks, posts, curbs, guard rails and fixed obstructions.
- **CLOSE** Mower door and stop operating if bystanders come within 300 feet of the mower.
- Keep mower door closed when cutting close to the ground.
- Open door only to cut large brush or tree limbs. Close door immediately after cutting limb.
- **DO NOT** push mower head down onto material to cut it, use the front tips of the mower blades to cut into the material.
- **DO NOT** operate mower when mower is in transport position.
- **STOP MOWING** immediately if blades strike heavy objects, fixed structures, metal guard rails and concrete structures:
 1. **BLADES CAN FAIL** from impact and objects can be thrown with great velocity.
 2. **INSPECT** and **REPLACE** any damaged blades.
 3. **CHECK** blade carrier and **REPLACE** if damaged.
- **DO NOT** mow in standing water **TO AVOID** possible **BLADE FAILURE**.
- **AVOID MOWING** in reverse:
 1. **STOP PTO** and back up mower.
 2. **LOWER** mower, engage **PTO** and mow forward.
- **DISENGAGE** mower head and wait until **BLADES** stop rotating before raising mower to transport position.
- **DO NOT ENGAGE PTO** with mower in transport position.
- **STOP** mowing when **EXCESSIVE VIBRATION** occurs:
 1. **STOP PTO** and tractor **ENGINE**.
 2. **INSPECT** mower for vibration source.
 3. **REPLACE** any damage parts and bent or damaged **BLADES**. *PN TOBM-02*

SAFETY

SAFETY

RUN OVER HAZARDS

| | | |
|---|---|---|
|  |  |  |
| Operator run over hazard | Rider fall off run over hazard | Bystander run over hazard |



TO AVOID SERIOUS INJURY OR DEATH FROM FALLING OFF TRACTOR OR EQUIPMENT RUN OVER:



- **USE ROPS** and **SEAT BELT** equipped tractors for mowing operations.
- **KEEP ROPS** locked in **UP** position.
- **ONLY** start tractor while seated in tractor seat.
- **ALWAYS BUCKLE UP** seat belt when operating tractor and equipment.
- **ONLY OPERATE** tractor and equipment while seated in tractor seat.
- **NEVER ALLOW RIDERS** on tractor or implement.
- When not mowing stow Boom and Mower head in transport location before moving.

WHEN MOUNTING AND DISMOUNTING TRACTOR:

- **ONLY** mount or dismount when tractor and moving parts are stopped.
- **STOP ENGINE AND PTO**, engage parking brake, lower implement, allow all moving parts to stop and remove key before dismounting from tractor. *PN ROBM-01*

SAFETY

PTO ENTANGLEMENT HAZARDS

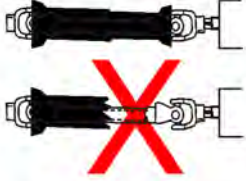
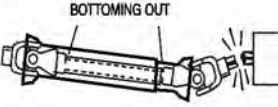
| | | | |
|---|--|--|--|
|  |  <p>PTO (Barra Gitoria)</p> |  |  <p>BOTTOMING OUT</p> |
| <p>Entanglement hazard Do Not approach or touch a rotating PTO driveshaft</p> | <p>Make sure PTO shaft is securely attached Do Not Use PTO Adapter</p> | <p>DO NOT Operate if PTO shields are damaged or missing</p> | <p>Make sure PTO shafts are proper length</p> |



KEEP AWAY FROM ROTATING DRIVELINES AND ELEMENTS TO AVOID SERIOUS INJURY OR DEATH:

STAY AWAY and **KEEP** hands, feet and body **AWAY** from rotating blades, drivelines and parts until all moving elements have stopped.

- **STOP, LOOK** and **LISTEN** before approaching the mower to make sure all rotating motion has stopped.
- **ROTATING COMPONENTS CONTINUE** to **ROTATE** after the PTO is shut off.

PTO SHIELDING:

TO AVOID SERIOUS INJURY OR DEATH FROM ENTANGLEMENT WHEN OPERATING IMPLEMENT:

- **KEEP PTO** shields, integral driveline shields and input shields installed
- **DO NOT OPERATE** mower without shields and guards in place or missing
- **REPAIR OR REPLACE** if damage, broken or missing
- **ALWAYS REPLACE GUARDS** that have been removed for service or maintenance.
- Do Not use PTO or PTO guard as a step.

TO AVOID broken driveline during operations:

- **CHECK** driveline for proper length between PTO shaft and implement gearbox shaft. *(Refer to Instructions in Operation Section)*
- Drivelines too short can pull apart or disengage.
- Drivelines too long can bottom out.
Bottoming driveline telescoping assembly will stop sliding and become solid.
- Driveline bottoming can push through support bearings and break off PTO shaft
- **AVOID** sharp turns or lift mower to heights to cause driveline "knocking".
- Lubricate driveshaft-telescoping components weekly.





CONTACT DEALER if implement driveline does not match Tractor PTO shaft:

- **DO NOT USE PTO ADAPTER.**

Using a PTO adapter can cause excessive vibration, thrown objects, blade and implement failures by doubling operating speed. Increased working length exposing unshielded driveline areas. *PN PE01*

SAFETY

MOWER BLADE CONTACT HAZARDS

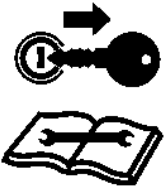
| | | | | | |
|---|---|---|--|---|---|
|  |  |  |  |  |  |
| Do not put fingers underneath mower | Do not put hands underneath Flail Mower | Do not put foot underneath mower | Do not put foot underneath Flail Mower | Shearing Hazard from Sickle blades | Stop Tractor Remove Key Read Manual |



KEEP AWAY FROM ROTATING BLADES TO AVOID SERIOUS INJURY OR DEATH FROM BLADE CONTACT:

- **STAY AWAY** and **KEEP HANDS, FEET** and **BODY AWAY** from rotating blades, drivelines and parts until all moving elements have stopped.
- **DO NOT** put hands or feet under mower decks
- **STOP** rotating **BLADES** disengage mower switch and PTO and wait for blade to stop rotating before raising mower head.
- **DO NOT** approach Sickle Bar head until Tractor Engine has been shut off.
- **STOP LOOK** and **LISTEN** before approaching the mower to make sure all rotating motion has stopped. *PN MBBM-01*

SAFETY

HIGH PRESSURE OIL LEAK HAZARD

| | | | |
|---|---|--|---|
|  |  |  |  |
| <p>High pressure oil penetrating skin</p> | <p>High pressure oil eroding skin</p> | <p>Using cardboard to check for oil leaks</p> | <p>Tank contents under pressure. Allow oil to cool before slowly removing cap</p> |



TO AVOID SERIOUS INJURY OR DEATH FROM HIGH PRESSURE HYDRAULIC OIL LEAKS PENERATING SKIN:

- **DO NOT OPERATE** equipment with oil or fuel leaks.
- **KEEP** all hydraulic hoses, lines and connections in **GOOD CONDITION** and **TIGHT** before applying system pressure.
- **RELIEVE HYDRAULIC PRESSURE** before disconnecting lines or working on the system.
- **REMOVE** and replace hose if you suspect it leaks. Have dealer test it for leaks.

HIGH PRESSURE FLUID LEAKS CAN BE INVISIBLE.

WHEN CHECKING FOR HYDRAULIC LEAKS AND WORKING AROUND HYDRAULIC SYSTEMS:

- **ALWAYS WEAR** safety glasses and impenetrable gloves.
- **USE** paper or cardboard to search for leaks.
- **DO NOT USE** hands or body parts to search for leak.
- **KEEP** hands and body **AWAY** from pin holes and nozzles ejecting hydraulic fluid.
- Hydraulic fluid may cause gangrene if not surgically removed immediately by a doctor familiar with this form of injury.

Use caution when removing Hydraulic Tank cap.

- Tank contents maybe under pressure
- Allow oil to cool before removing cap.
- Relieve oil pressure before removing cap slowly.
- Stay away from hot oil that may spray from tank.

PN HPBM-01

SAFETY

ELECTRICAL & FIRE HAZARDS

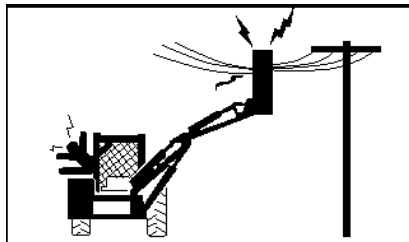

Mower head or Boom contacting overhead electrical lines



Strike and explosion Hazard
Blades Contacting Utility or Gas Lines

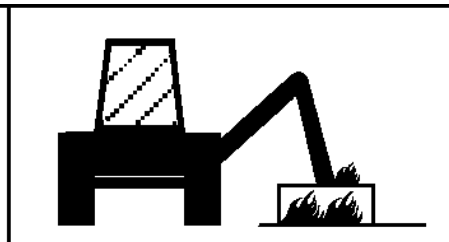

Fire Hazard Do Not operate near fires. Keep debris away from hydraulic pumps and valves



TO AVOID SERIOUS INJURY OR DEATH FROM ELECTRICAL CONTACT WHEN WORKING AROUND ELECTRICAL POWER LINES, GAS LINES AND UTILITY LINES:

- **INSPECT** mowing area for overhead or underground electrical power lines, obstructions, gas lines, cables and Utility, Municipal, or other type structure.
- **KEEP** all raised wings at a 10 feet or greater distance from all power lines and overhead obstructions.
- **DO NOT** allow mower to contact with any Utility, Municipal, or type of structures and obstructions.
- **CALL 811** and 1-800-258-0808 for identify buried utility lines.

FIRE PREVENTION GUIDELINES while Operating, Servicing, and Repairing Mower and Tractor to reduce equipment and grass fire Risk:

- **EQUIP** Tractor with a **FIRE EXTINGUISHER**
- **DO NOT OPERATE** mower on a tractor equipped with under frame exhaust
- **DO NOT SMOKE** or have open flame near Mower or Tractor
- **DO NOT DRIVE** into burning debris or freshly burnt area
- **AVOID FIRE IGNITION** by not allowing mower blade to contact solid objects like metal or rock.
- **DO NOT** operate if oil is leaking. Repair oil leak and remove all accumulated oil before operating.
- **CLEAR** any grass clippings or debris buildup around mower hydraulic pumps, valves or tanks.
- **SHUT OFF ENGINE** while refueling. *PN EFBM-01*

SAFETY

TRANSPORTING HAZARDS

| | | |
|---|---|---|
|  |  |  |
| <p>Use SMV signs and Flashing Lights</p> | <p>Loss of Control Stopping Hazard</p> | <p>Loss of Control Speeding Hazard</p> |

WARNING TO AVOID SERIOUS INJURY AND DEATH WHEN TOWING OR TRANSPORTING EQUIPMENT:

- **KEEP** transport speed **BELOW** 20 mph to maintain control of equipment.
- **REDUCE SPEED** on inclines, on turns and in poor towing conditions.
- **DO NOT TOW** with trucks or other vehicles.
- **USE** only properly sized and equipped tractor for towing equipment.
- **FOLLOW** all local traffic regulations.

TRACTOR REQUIREMENTS FOR TOWING OR TRANSPORTING IMPLEMENTS:

- **ONLY TRANSPORT** with tractor with **ROPS** in the raised position.
- **USE** properly sized and equipped tractor that exceeds implement weight by at least 20%.
- **KEEP** 20% of tractor weight on front wheels to maintain safe steering.

BEFORE TRANSPORTING OR TOWING IMPLEMENT:

TRACTOR INSPECTION:

- **CHECK** steering and braking for proper operation and in good condition.
- **CHECK SMV** sign, reflectors and warning lights for proper operation and visibility behind unit.
- **CHECK** that your driving vision is not impaired by tractor, cab, or implement while seated in tractor seat.
- **ADJUST** your operating position, mirrors, and implement transport for clear vision for traveling and traffic conditions.

PREPARE IMPLEMENT FOR TRANSPORTING OR TOWING:

- Store Boom and Mower in transport positions and engage transport locks if equipped.

DETERMINE STOPPING CHARACTERISTICS OF TRACTOR AND IMPLEMENT FOR TRANSPORTING OR TOWING:

BRAKING TESTS:

- Stopping distance with implement attached may increase
- Observe **STOPPING** distances increases with increased speeds.
- **DETERMINE** the maximum safe transport speed that does not exceed 20 mph.
- Reduce travel speed in wet or icy roads, stopping distances increase.

DETERMINE MAXIMUM TURNING SPEED BEFORE OPERATING ON ROADS OR UNEVEN GROUND:

- **TEST** equipment in slowly increasing speed in turns to determine it can be operated at higher speeds.
- **USE REDUCED** turning speeds in sharp turns to avoid equipment turning over.





WHEN TOWING OR TRANSPORTING EQUIPMENT:

- Always **WEAR SEAT BELT** when operating or transporting mower.
- **USE** low speeds to avoid overturn with raised wings.
- **USE** low speeds and gradual steering on curves, hills, rough or uneven surfaces and on wet roads.
- **TURN ON** tractor **FLASHING WARNING LIGHTS**.
- **ALLOW** clearance for implement swing while turning.

KEEP raised boom mower 10 feet or greater distance from all power lines and overhead obstructions. *PN THBM-01*

SAFETY

HAZARDS WITH MAINTENANCE OF IMPLEMENT

| | | | | |
|--|---|---|--|---|
|  |  |  |  |  |
| Periodically inspect all moving parts, lubricate drivelines, and tighten all fasteners | Lower mower head to ground or block up before servicing | Stop engine remove key before conducting maintenance | Set mower head securely on the ground before servicing blades | Thrown Objects Hazard Ensure blades rotate clockwise viewed from above mower head |



AVOID SERIOUS INJURY OR DEATH FROM COMPONENT FAILURE BY KEEPING IMPLEMENT IN GOOD OPERATING CONDITION IN PERFORMING PROPER SERVICE, REPAIRS AND MAINTENANCE.

BEFORE PERFORMING SERVICE, REPAIRS AND MAINTENANCE ON THE IMPLEMENT:

- **STOP ENGINE AND PTO**, engage parking brake, lower implement, allow all moving parts to stop and remove key before dismounting from tractor.
- **PLACE** implement on ground or securely block up raised equipment. Use large blocks on soft or wet soil.
- **PUSH** and **PULL** Remote Hydraulic Cylinder lever to relieve hydraulic pressure.
- **DISCONNECT Pump solenoid valve or PTO driveline connection before servicing mower head.**
- **WEAR SAFETY GLASSES, PROTECTIVE GLOVES** and follow **SAFETY PROCEDURES** when performing service, repairs and maintenance on the implement:
 - Always **WEAR** protective **GLOVES** when handling blades, knives, cutting edges or worn component with sharp edges.
 - Always **WEAR GLOVES** and **SAFETY GLASSES** when servicing hot components
 - **AVOID CONTACT** with hot hydraulic oil tanks, pumps, motors, valves and hose connection surfaces.
 - **SECURELY** support or **BLOCK UP** raised implement, framework and lifted components before working underneath equipment.
 - **FOLLOW INSTRUCTIONS** in maintenance section when replacing hydraulic cylinders to prevent component falling.
 - **STOP** any implement movements and **SHUT-OFF TRACTOR** engine before doing any work procedures.
 - **USE** ladder or raised stands to reach high equipment areas inaccessible from ground.
 - **ENSURE** good footing by standing on solid flat surfaces when getting on implement to perform work.
 - **FOLLOW** manufacturer's instructions in handling oils, solvents, cleansers, and other chemical agents.
 - **DO NOT** change any factory-set hydraulic calibrations to avoid component or equipment failures.
 - **DO NOT** modify or alter implement, functions or components.
 - **DO NOT WELD** or repair rotating mower components. These may cause vibrations and component failures being thrown from mower.

PERFORM SERVICE, REPAIRS, LUBRICATION AND MAINTENANCE OUTLINED IN IMPLEMENT MAINTENANCE SECTION:

- **INSPECT** for loose fasteners, worn or broken parts, leaky or loose fittings, missing or broken cotter keys and washers on pins, and all moving parts for wear.
- **REPLACE** any worn or broken parts with authorized service parts.
- Inspect mower blade spindle to ensure bearing preload. If loose repair before operating.
- **LUBRICATE** unit as specified by lubrication schedule
- **NEVER** lubricate, adjust or remove material while it is running or in motion.
- **TORQUE** all bolts and nuts as specified.

BLADE INSPECTION:

- Inspect blade carrier and blades daily.
- Check blade and blade carrier **BOLT TORQUE** daily. Loose bolts can cause blade or blade bolt failures.
- **REPLACE**, bent, damage, cracked and broken blades immediately with new blades.
- **AVOID** blade failures and thrown broken blades. **DO NOT** straighten, weld, or weld hard-facing blades.

SAFETY SHIELDS, GUARDS AND SAFETY DEVICES INSPECTION:

- **KEEP** all Deflectors, Chain Guards, Steel Guards, Gearbox Shields, and PTO integral shields, Bands, Side Skirts and Skid Shoes in place and in good condition.
- **REPLACE** any missing, broken or worn safety shields, guards and safety devices.
- Engine Exhaust, some of its constituents, and certain vehicle components contain or emit chemicals known to the state of California to cause cancer, birth defects or other reproductive harm.
- Battery posts, terminals and related accessories contain lead and lead compounds, chemicals known to the state of California to cause cancer, birth defects or other reproductive harm. **PN HMBM-01**

SAFETY

PARTS INFORMATION

PARTS INFORMATION

Tiger mowers use balanced and matched system components for blade carriers, blades, cuttershafts, knives, knife hangers, rollers, drivetrain components, and bearings. These parts are made and tested to Tiger specifications. Non-genuine "will fit" parts do not consistently meet these specifications. The use of "will fit" parts may reduce mower performance, void mower warranties, and present a safety hazard. Use genuine Tiger mower parts for economy and safety. (SPTM-1)

SEE YOUR TIGER DEALER

Operator's & Parts Manuals



www.algqr.com/tpm

SAFETY

SAFETY

SAFETY

Decal Location Tractor and Side Rotary Mower

NOTE: Tiger supplies safety decals on this product to promote safe operation. Damage to the decals may occur while in shipping, use, or reconditioning. Tiger cares about the safety of its customers, operators, and bystanders, and will replace the safety decals on this product in the field, free of charge (Some shipping and handling charges may apply). Contact your Tiger dealer to order replacement decals.

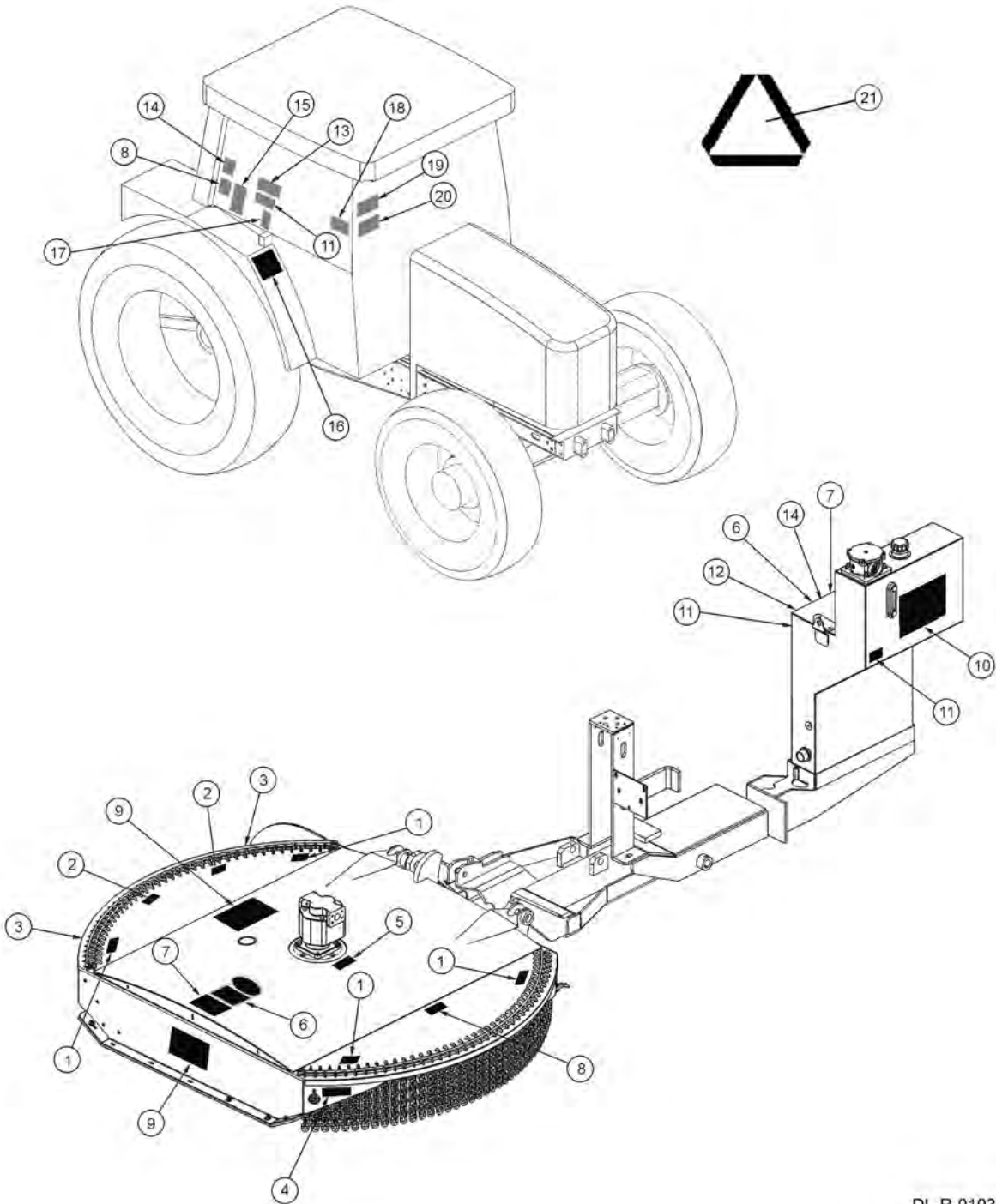

DL-R-0103

SAFETY

SAFETY

| ITEM | PART NO. | QTY | LEVEL | DESCRIPTION |
|------|----------|-----|-------------|---|
| 1. | 6T3217 | 4 | DANGER | Keep Hands and Feet Clear |
| 2. | 6T3224 | 2 | DANGER | Stay Clear, Discharge Opening |
| 3. | 42399 | 2 | REFLECTOR | Red Reflector |
| 4. | 42400 | 1 | REFLECTOR | Amber Reflector |
| 5. | 22839 | 1 | CAUTION | Do Not Grease w/ Automatic Grease Gun |
| 6. | 32709 | 2 | IMPORTANT | Use Tiger Genuine Parts |
| 7. | 6T3236 | 2 | LOGO | Made in U.S.A. |
| 8. | 22840 | 2 | WARNING | Foreign Objects Contracted |
| 9. | 31522 | 2 | LOGO | Tiger Logo (10" x 5.5") |
| 10. | 31523 | 1 | LOGO | Tiger Logo (18.25" x 10") |
| 11. | 6T3233 | 2 | IMPORTANT | Do Not Start/Run with Valves Closed |
| 12. | 34852 | 1 | INFORMATION | Mowers Chart |
| 13. | 6T3243 | 1 | WARNING | Replacing Blades |
| 14. | 6T3219 | 1 | WARNING | Read Operator's Manual Before Operating |
| 15. | 33743 | 1 | INSTRUCT | Mowing Tips |
| 16. | 02967827 | 1 | DANGER | Multi-Hazard |
| 17. | 6T3222 | 1 | NOTICE | Engine Will Not Start when Mower is Engaged |
| 18. | 6T3221 | 1 | CAUTION | Lubricate Spindle Daily or Every 10 Hours |
| 19. | 6T3230 | 1 | WARNING | Do Not Operate w/ Bystanders in Area |
| 20. | 1059 | 1 | INSTRUCT | Mower Positions |

SAFETY

SAFETY

Decal Location Rear Rotary

NOTE: Tiger supplies safety decals on this product to promote safe operation. Damage to the decals may occur while in shipping, use, or reconditioning. Tiger cares about the safety of its customers, operators, and bystanders, and will replace the safety decals on this product in the field, free of charge (Some shipping and handling charges may apply). Contact your Tiger dealer to order replacement decals.

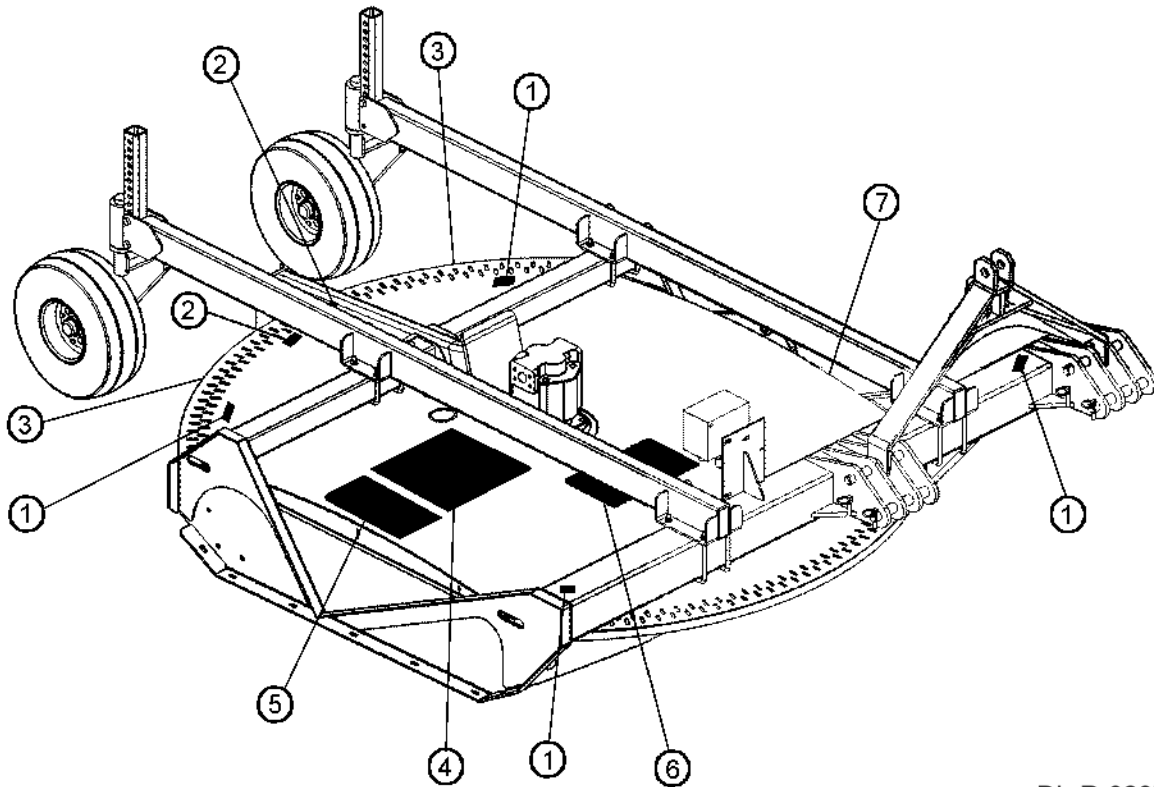

DL-R-0287

| ITEM | PART NO. | QTY | LEVEL | DESCRIPTION |
|------|----------|-----|------------|-------------------------------|
| 1. | 6T3217 | 4 | DANGER | Keep Hands and Feet Clear |
| 2. | 6T3224 | 2 | DANGER | Stay Clear, Discharge Opening |
| 3. | 42399 | 2 | REFLECTOR | Red Reflector |
| 4. | 32709 | 1 | IMPORTANT | Use Tiger Genuine Parts |
| 5. | 6T3236 | 1 | LOGO | Made in U.S.A. |
| 6. | 31522 | 1 | LOGO | Tiger Logo (10" x 5.5") |
| 7. | NFS | 1 | SERIAL NO. | Serial Number Plate |

SAFETY

Decal Description



SAFETY

SAFETY

SAFETY

⚠ WARNING

Non-genuine parts can fail catastrophically. TO AVOID SERIOUS INJURY OR DEATH:

- ONLY use genuine TIGER replacement parts.
- Non-genuine parts can fail creating hazardous conditions for operator and bystanders.

Contact local dealer or TIGER about repair parts at:
3301 N. LOUISE AVE.,
SIOUX FALLS, SD 57107 www.algqr.com/tpm
Customer Service: 800-843-6849.
Email: feedback@tiger-mowers.com 32709 1



IMPORTANT

BE AWARE BE TRAINED
BE ALERT Before Operating this Mower
BE ALIVE

To prevent serious injury to yourself and/or bystanders, be trained in Safe Mowing Practices. Alamo Group Companies as well as AEM and FEMA provide training material that is critical for your Safety and the Safety of others when operating this equipment. www.algqr.com/tbv
Make these Safety Procedures an important part of every workday. Read and understand the Operator's Manual. Do not let untrained individuals operate this equipment. Contact your Dealer, AEM (www.aem.org), FEMA (314-878-2304, www.FarmEquip.org), or Alamo Group (www.Alamo-Group.com) for information on training material or courses that provide training in Safer Operating Practices for Mowers. 32709 2



| | |
|--|---|
| <p>⚠ WARNING</p> <p>IT IS RECOMMENDED THAT THE BOLT AND LOCKNUT BE REPLACED WHENEVER BLADES ARE REPLACED. REPLACE THESE ANYTIME THEY ARE DAMAGED OR WORN AS FAILURE TO DO SO CAN LEAD TO BLADES COMING OFF CAUSING SERIOUS INJURY OR DEATH.</p> | <p>IMPORTANT</p> <ul style="list-style-type: none">• WHEN REPLACING BLADES, IT IS RECOMMENDED THAT ALL BLADES BE REPLACED FOR PROPER BALANCE TO AVOID EXCESSIVE VIBRATIONS WHICH CAN DAMAGE SPINDLE ASSEMBLY.• SEE YOUR OPERATOR'S MANUAL FOR PROPER INSTALLATION INSTRUCTIONS. <p>6T3243</p> |
|--|---|

SAFETY

| | |
|--|--|
|  WARNING | |
|  | <p>If Foreign Objects are Accidentally Contacted Shut Control Switch Off Immediately. Do Not Raise Cutter Head Until All Moving Parts Have stopped. Inspect Blade Before Operating Mower.</p> <p>22840</p> |

| |
|--|
|  WARNING |
| <p>DO NOT OPERATE THIS EQUIPMENT WITH BYSTANDERS IN THE AREA!</p> <p>ROTARY MOWERS HAVE THE INHERENT ABILITY TO THROW DEBRIS CONSIDERABLE DISTANCES WHEN KNIVES ARE ALLOWED TO STRIKE FOREIGN OBJECTS. OPERATOR CAUTION MUST BE TAKEN OR SERIOUS INJURY CAN RESULT.</p> <p>6T3230</p> |

| |
|---|
|  WARNING |
| <p><u>FOR SAFE OPERATION</u> READ THE OPERATORS & MAINTENANCE MANUAL BEFORE OPERATING</p> <p>6T3219</p> |

SAFETY

SAFETY

! DANGER

02967827_1

THROWN OBJECTS HAZARD

Mower can throw objects up to 300 feet. TO AVOID SERIOUS INJURY OR DEATH to operator or bystanders:

- STOP mowing if bystanders or traffic come within 300 feet.
- DO NOT OPERATE with thrown object shielding removed.
- KEEP thrown object shielding in place and in good condition during operation. Thrown Objects shielding is subject to wear.
- REPAIR OR REPLACE shielding if damaged, broken or missing. See Operator's Manual for all Shields and Guards.
- INSPECT area for potential mower thrown object hazards before mowing.
- Remove and AVOID objects such as wire, cable, metal objects and all other foreign material.
- DO NOT ALLOW blades to contact solid objects like wire, rocks, posts, curbs or guard rails.
- DO NOT operate without operator protective shielding or cab.

! DANGER



Run Over Hazard - Injury or Death

TO AVOID SERIOUS INJURY OR DEATH:

- ALWAYS BUCKLE UP seat belt.
- ONLY START Tractor while seated in the operator's seat.
- STOP ENGINE and PTO, engage parking brake, lower implement, allow all moving parts to stop and remove key before dismounting from tractor.
- KNOW HOW to stop tractor and equipment quickly for an emergency.
- DO NOT MOUNT or DISMOUNT Tractor in motion.
- NEVER ALLOW riders on tractor or implement.
- NEVER ALLOW children to operate or ride on tractor or implement.
- KEEP BYSTANDERS CLEAR of area before moving tractor or implement.
- KEEP ALERT and AVOID hitting stumps, holes, ruts, and uneven terrain.
- AVOID tree limbs, brush and other overhanging objects that can strike and throw the operator from seat.

02967827_4

SAFETY

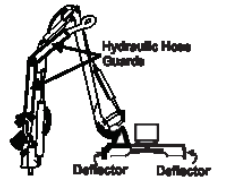
| | |
|--|--|
| ⚠ DANGER | |
| ENTANGLEMENT HAZARD |  |
| <p>TO AVOID SERIOUS INJURY OR DEATH:</p> <ul style="list-style-type: none"> • DO NOT operate without guards in place and in good condition. PTO and gearbox guarding are SUBJECT TO WEAR. • STAY AWAY and KEEP hands, feet and body AWAY from rotating blades, drivelines and parts that continue to move after power shut-off. WAIT until all moving elements have stopped. • ALWAYS REPLACE GUARDS that have been removed for service or maintenance. • STOP, LOOK and LISTEN for rotating motion before approaching implement. | <div style="text-align: center;">   <p>Hydraulic Hose Guards Deflector Deflector</p> </div> |
| 02967827_2 | |

| | |
|---|--|
| ⚠ DANGER | |
| Crushing Hazard - Injury or Death | |
| <p>TO AVOID SERIOUS INJURY OR DEATH: 02967827_3</p> <ul style="list-style-type: none"> • USE tractor equipped with <u>R</u>ollover <u>P</u>rotective <u>S</u>tructure ("ROPS") including roll bar and seat belt. Keep roll bar in raised position. • CLEAR AREA of bystanders before raising or lowering mower. • IMPLEMENT CAN FALL from hydraulic failure or accidental operation of controls. • BLOCK UP and securely support equipment before putting hands, feet or body under raised equipment or lifted components. | <div style="text-align: center;">   </div> |

| | | | |
|--|---|--|---|
| ⚠ DANGER | | | |
|  |  |  |  |
| 02967827_5 | www.algqr.com/tbe | | |
| <p>TO AVOID SERIOUS INJURY OR DEATH:</p> <ul style="list-style-type: none"> • READ AND UNDERSTAND the provided Operator's Manuals, safety signs and information decals for tractor and implement before operating equipment. • CONTACT DEALER immediately if you do not have manuals. • CONTACT DEALER to explain any instructions not fully understood. • ALWAYS WEAR safety glasses. • WEAR hard hat, safety shoes and gloves for protection when operating equipment. | | | 02967827 |

SAFETY

Federal Laws and Regulations

This section is intended to explain in broad terms the concept and effect of federal laws and regulations concerning employer and employee equipment operators. This section is not intended as a legal interpretation of the law and should not be considered as such.

Employer-Employee Operator Regulations

U.S. Public Law 91-596 (The Williams-Steiger Occupational and Health Act of 1970) OSHA

This Act Seeks:

"...to assure so far as possible every working man and woman in the nation safe and healthful working conditions and to preserve our human resources..."

DUTIES

Sec. 5 (a) Each employer-

- (1) shall furnish to each of his employees employment and a place of employment which are free from recognized hazards that are causing or are likely to cause death or serious physical harm to his employees;
- (2) shall comply with occupational safety and health standards promulgated under this Act.
- (b) Each employee shall comply with occupational safety and health standards and all rules, regulations and orders issued pursuant to this Act which are applicable to his own actions and conduct.

OSHA Training Requirements

Title 29, Code of Federal Regulations Part 1928.57(a)(6). www.osha.gov

Operator instructions. At the time of initial assignment and at least annually thereafter, the employer shall instruct every employee who operates an agricultural tractor and implements in the safe operating practices and servicing of equipment with which they are or will be involved, and of any other practices dictated by the work environment.

Keep all guards in place when the machine is in operation;

Permit no riders on equipment

Stop engine, disconnect the power source, and wait for all machine movement to stop before servicing, adjusting, cleaning or unclogging the equipment, except where the machine must be running to be properly serviced or maintained, in which case the employer shall instruct employees as to all steps and procedures which are necessary to safely service or maintain the equipment.

Make sure everyone is clear of machinery before starting the engine, engaging power, or operating the machine.

Employer Responsibilities:

To ensure employee safety during Tractor and Implement operation, it is the employer's responsibility to:

1. Train the employee in the proper and safe operation of the Tractor and Implement.
2. Require that the employee read and fully understand the Tractor and Implement Operator's manual.
3. Permit only qualified and properly trained employees to operate the Tractor and Implement.
4. Maintain the Tractor and Implement in a safe operational condition and maintain all shields and guards on the equipment.
5. Ensure the Tractor is equipped with a functional ROPS and seat belt and require that the employee operator securely fasten the safety belt and operate with the ROPS in the raised position at all times.
6. Forbid the employee operator to carry additional riders on the Tractor or Implement.
7. Provide the required tools to maintain the Tractor and Implement in a good safe working condition and provide the necessary support devices to secure the equipment safely while performing repairs and service.
8. Require that the employee operator stop operation if bystanders or passersby come within 300 feet.

Child Labor Under 16 Years of Age

Some regulations specify that no one under the age of 16 may operate power machinery. It is your responsibility to know what these regulations are in your own area or situation. (Refer to U.S. Dept. of Labor, Employment Standard Administration, Wage & Home Division, Child Labor Bulletin #102.)

ASSEMBLY SECTION

ASSEMBLY

Before attempting to mount your Tiger mower, it is important to read and understand all of the safety messages in the Safety Section of this manual.

Check complete shipment list against the packing list to make sure there are no shortages. Make certain the tractor model is the appropriate one for the mower received!



Always use a floor jack, hoist or fork lift to lift and raise heavy parts.

Read and understand the entire Assembly Section instructions before attempting to mount your Tiger mower. Refer to the Parts Section of this manual for detailed illustrations to locate all parts. (ASM-C-0001)

TRACTOR PREPARATION

- A. Remove right and left hand steps.
- B. Disconnect battery cables from both batteries.
- C. Remove engine side panels, or raise hood to access front pulley.
- D. Remove plugs from tractor casting where mainframe and pump mount will be attached.
- E. Remove any front weights and weight supports.
- F. Raise the tractor onto jack-stands and remove the right and left rear wheels.

(ASM-C-0024)

CRANKSHAFT ADAPTER

If necessary, remove the four capscrews from the crankshaft pulley. Then install the crankshaft adapter to the pulley with capscrews and lockwashers as shown in the Parts Section.

(ASM-NH-0050)



ASSEMBLY

BATTERY RELOCATION

Installation of the pump driveshaft requires that the battery be raised to allow the driveshaft to pass beneath it from the crankshaft adapter to the pump. Disconnect and remove the battery from the well in the front of the tractor. Place the battery relocation assembly #06370267 in the battery well and secure through the bottom of the tractor casting as shown in the Parts Section. Run capscrew #21332 through the hole in the rear of the bottom level of relocation assembly #06370267 using insulated washers #06510260 above and below. Run new battery cable #06510299 from positive post on battery to capscrew. Connect new positive battery post to cap-screw. Connect the existing positive battery cable to the new post. Use the battery strap, cap-screws, flatwashers and u-nuts provided to secure the battery to the relocation assembly. See the Battery Relocation page in the Parts Section for more information.

(ASM-NH-152 BATTERY TS6 1xx T4B)

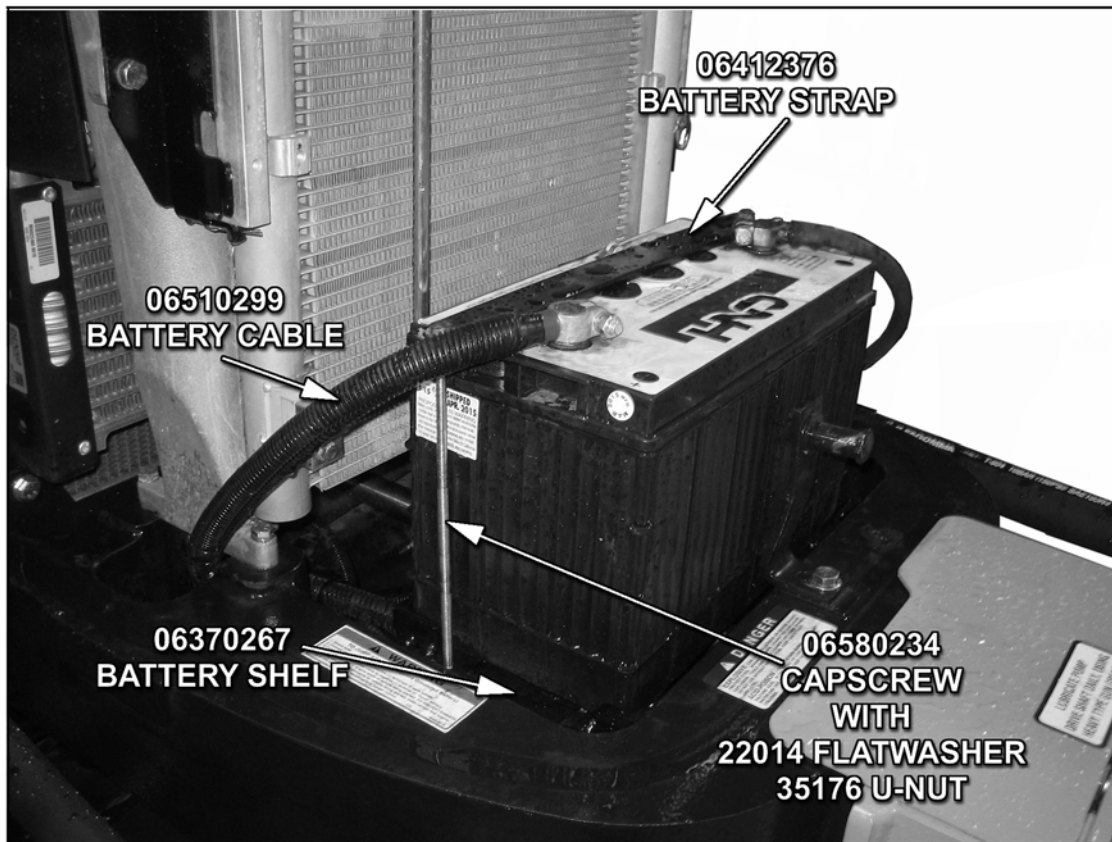

ASSEMBLY

COOLER HINGE REPLACEMENT

Installation of the pump driveshaft requires that the hinge on the tractor cooler be replaced to allow the driveshaft to pass beneath it from the crankshaft adapter to the pump. Remove the hinge mount and pin and replace with the Tiger hinge mount (#06412375) and pin (#06420188) provided. (ASM-NH-152 COOLER HINGE TS6 1xx T4B)

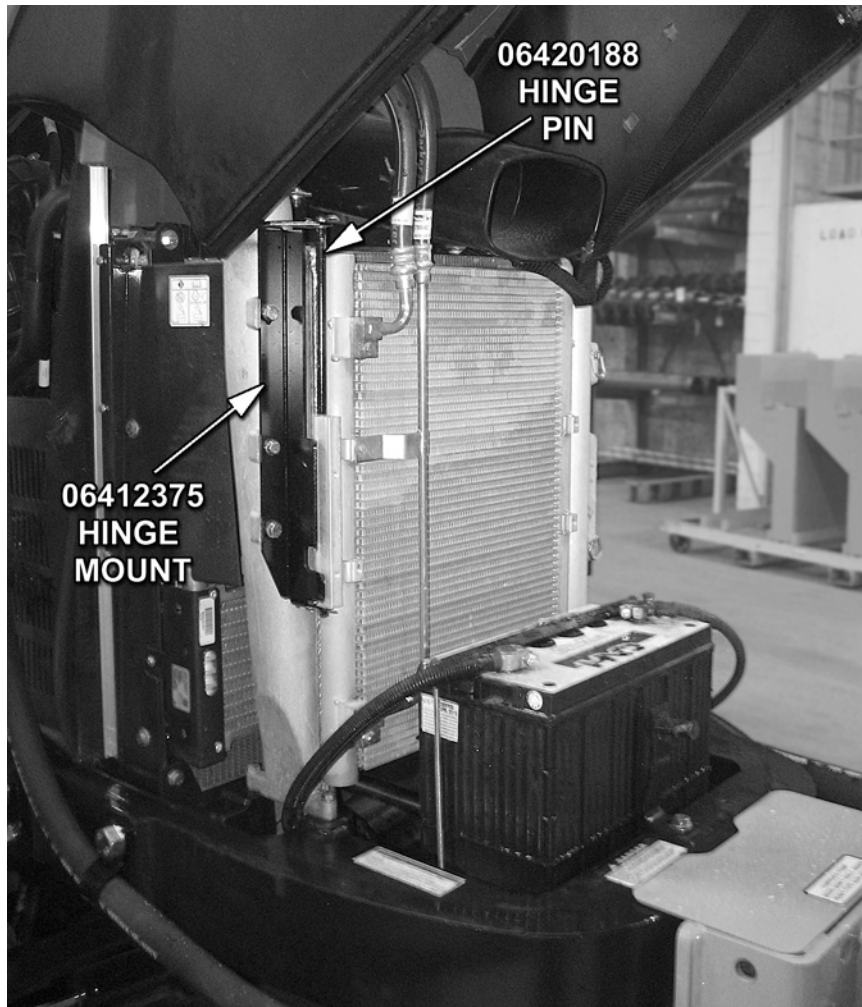

ASSEMBLY

FRONT PUMP MOUNTING

Install the pump mounting bracket on the front of the tractor with capscrews and washers as shown in the Parts Section illustration. DO NOT tighten fasteners at this time.

Thread the pump driveshaft into the crankshaft adapter. The end with the splines should match up with the coupler.

Slide the splined drive shaft coupler onto the pump driveshaft. Install the pump onto the mounting bracket. NOTE: The shaft is offset to one direction, the pump should be installed with the offset side on top. Install hardware for securing pump to the pump mount, DO NOT tighten.

Align pump so that splined coupling can be moved back and forth by hand. Tighten pump mounting bolts in succession, rechecking for spline coupling movement. Remove the pump mounting bracket bolts one at a time and apply a thread locking agent. Tighten these bolts in succession, again checking for free movement in the driveshaft. After all bolts are torqued, the end play on the driveshaft should be 1/16" to 1/8", and the coupler should move freely with hand pressure. If end play is less than 1/16", grind the end of the shaft to achieve the proper end play. If there is more than 1/4" of end play, return the shaft with specifications for a longer shaft.

CAUTION: DO NOT START THE TRACTOR UNTIL ALL HOSES ARE ATTACHED, TANK IS FILLED WITH PROPER OIL AND BALL VALVES ARE OPEN! STARTING AT THIS TIME WILL CAUSE SERIOUS DAMAGE TO THE PUMP. (ASM-NH-0024)

ADJUSTING REAR WHEELS

Raise rear of tractor onto jack-stands. Follow the instructions in the tractor owner's manual for adjusting tires and rims to 72" center for side mounted mowers and 79.8" for boom mowers. NOTE: This may require switching the wheels to opposite sides of tractor. Also take note of any width restrictions when transporting by trailer. (For ease of installation, it is best to leave the rear wheels removed during installation of the mower.) (ASM-NH-0051)



ASSEMBLY

APPLICATION OF LOCTITE 2047 MOWER MAINFRAME MOUNTING BOLTS

All mower mainframe mounting bolts shall be secured utilizing Loctite 2047 and torqued per the Torque Chart in the maintenance section. Shake bottle for 60 seconds before use. To prevent clogging of nozzle, do not allow tip to touch metal surfaces during application. If tip of nozzle becomes clogged, cut off tip as required. If female threads are contaminated or rusty, clean threads by using a thread chaser prior to installation of bolts. Apply thread locker to threads of bolts as shown below. The allowable fixture time is (1) hour maximum. Therefore bolts must be torqued within this time limit. The cure time is 72 hours at room temperature, therefore machine is not to be used in actual application, except for function testing, until the Loctite is allowed to cure.

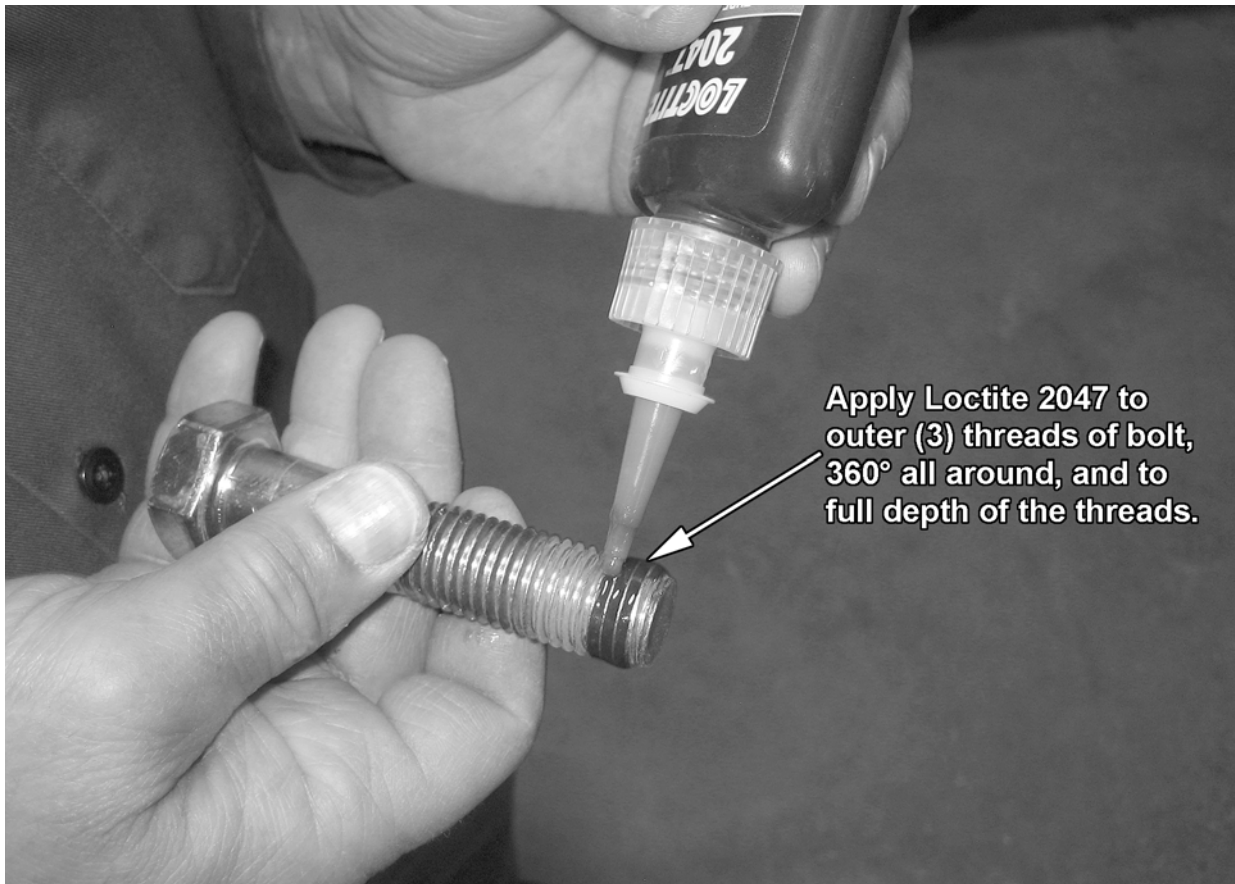

Apply Loctite 2047 to outer (3) threads of bolt, 360° all around, and to full depth of the threads.

(ASM-C-LOCTITE MNT BOLTS)



ASSEMBLY

POLYCARBONATE SAFETY WINDOW

NOTE: Installing a boom mower requires that all of the right side windows be replaced, or protected with a polycarbonate window. This should be done before mounting the mainframe.

1. Disconnect gas shock at door. Remove the right side cab door/window glass from tractor cab by removing hinge pins. Also, remove rear right side window.
2. Remove the existing hardware, door handle and bar handle and discard factory glass door and window.
3. Place small bead of adhesive seal in the bottom of the trim lock bubble seal.
4. Install trim lock bubble seal on polycarbonate starting at the center bottom horizontal portion.
5. Install existing hardware removed from glass door and window on the polycarbonate.
6. Install the polycarbonate assembly in the cab with existing and supplied hardware as shown in the Parts Section.
7. Assemble corner bracket to the control stand inside the cab.
8. Locate and drill a $\text{Ø}1/4$ " hole through polycarbonate, with a bit that is **only** used for polycarbonate, to match the corner bracket.
9. Assemble the bracket and tighten the hardware to secure the polycarbonate.
10. Assemble the clamp in the upper front corner by the mirror.
11. Adjust the clamp to achieve a secure hold.
12. Replace the rear corner window with the hardware removed from the window.

(ASM-NH-0101)

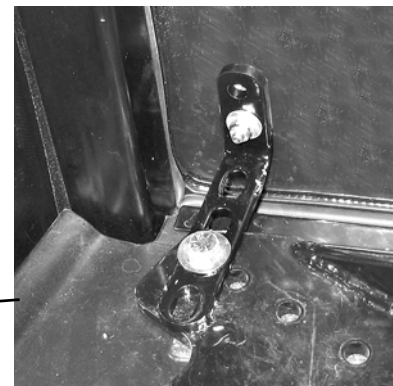
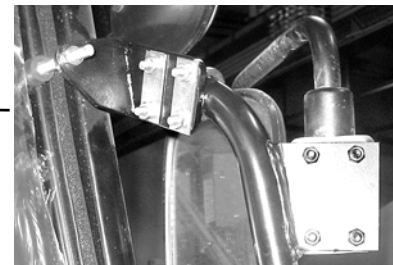

INSIDE
VIEW



ASSEMBLY

FENDER CUT

Installation of the wheel well tank may require modification of the left fender, as shown below. Before cutting the fender, mask the uncut area to prevent scratches. Cut to the approximate size shown below. After cutting TrimLock may be applied to the edges. (ASM-NH TS6 130 FENDER CUT



MAINFRAME INSTALLATION

NOTE: Before installing the axle braces, upright and mainframe, remove the left hand steps. Loosen the fuel tank and slide out two or three inches to provide space to install the left upright plate.

With an overhead hoist and / or jack-stands, raise one side of the frame up to the correctly matching mounting holes. Install capscrews and other hardware to secure the sides of the mainframe to the tractor casting, as shown on the tractor mount kit page in the Parts Section. DO NOT tighten at this time. Remove the capscrews one at a time and apply a thread locking agent. Reinsert the capscrews and tighten / torque to values noted in the torque chart located in the Maintenance Section of this manual. (ASM-NH Mainframe Installation TS6 1xx T4F)



ASSEMBLY

CABLE CONTROL/JOYSTICK STAND

For some control stand fittings a cable control support plate and spacers are mounted to the floor of the cab and the support stand is attached to the plate. Be sure that the location of the stand will allow clearance between the cable control handles and all existing interior levers, etc. Also, watch out for wiring and brackets underneath the cab when placing the support plate and bracket for drilling.

See the Parts Section for hardware used. (ASM-NH-0105e)

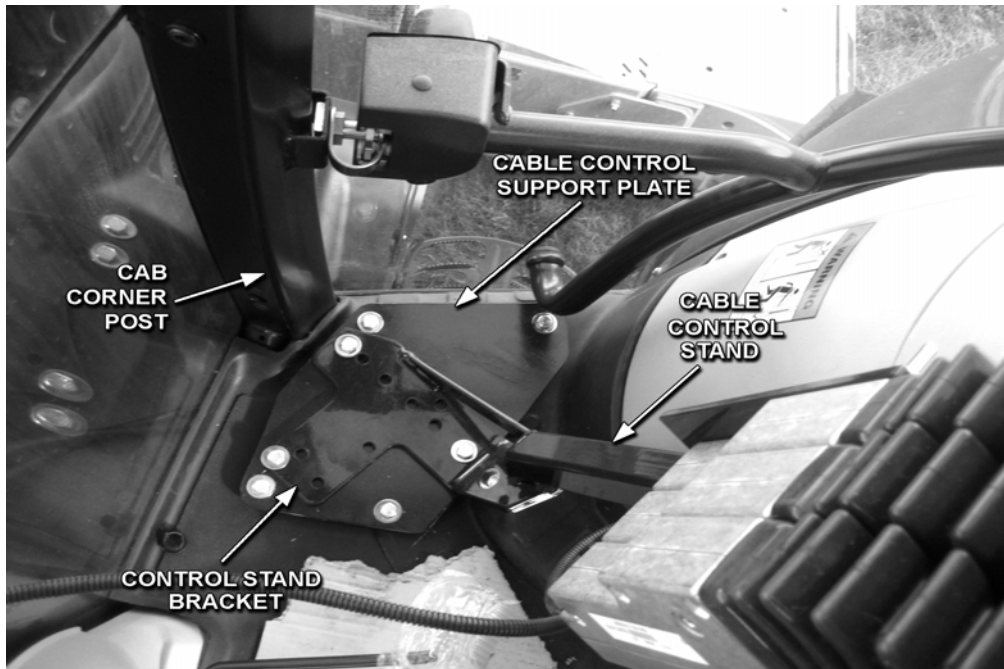

ASSEMBLY

MANUAL SWITCHBOX MOUNTING

The switchbox is to be secured to the operator's side of the control handles, or valve stand. Refer to the Parts Section for assembly and components needed. (ASM-C-0053d)



ASSEMBLY

TRAVEL LOCK SWITCH

Mount the switch for the electronic travel lock on the right side of the cable control stand as shown in the photo below. Switch #34532 is to be inserted in travel lock mounting bracket #34874 and attached to the cable control stand using capscrew #21545. See the instructions for the 3 Spool Cable Control Mount in the Parts Section for more information.

(ASM-NH-TRAVEL LOCK SWITCH T6 155)



ASSEMBLY

SWITCHBOX WIRING

Refer to the Parts Section for wiring diagrams. Remove top instrument panel (tach and hour meter) for access to the wires.

Route the red and green switch box wires from the switchbox to the bottom right corner of the instrument panel near window. Connect the red wire to the white wire. (hot when key is in the 'on' position)

NOTE ONLY FOR ELECTRONIC VALVE: +12 VOLTS ELECTRICAL POWER MUST BE TAKEN FROM A SOURCE LOCATION WHERE IT IS LIVE ONLY WHEN THE IGNITION SWITCH IS IN THE "ON" POSITION. THIS WIRE MUST BE FUSED AT THE SOURCE LOCATION.

Route the white wire to the hydraulic solenoid brake valve.

The switchbox is to be secured to the operator's side of the control handles, or corner switch box mount.

The green wires will connect to the neutral safety switch wires (white with yellow stripe), under the cowl panel. (ASM-NH-0061)

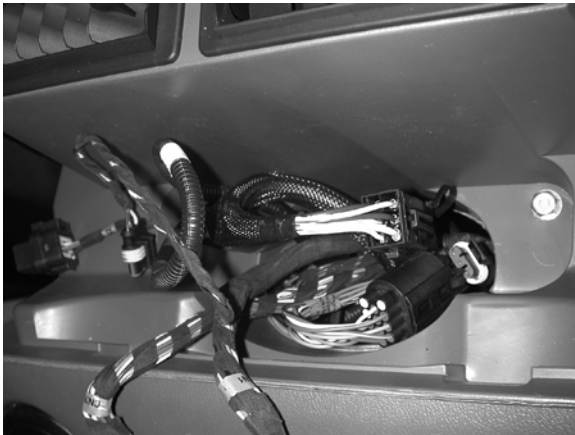

BEFORE WIRING

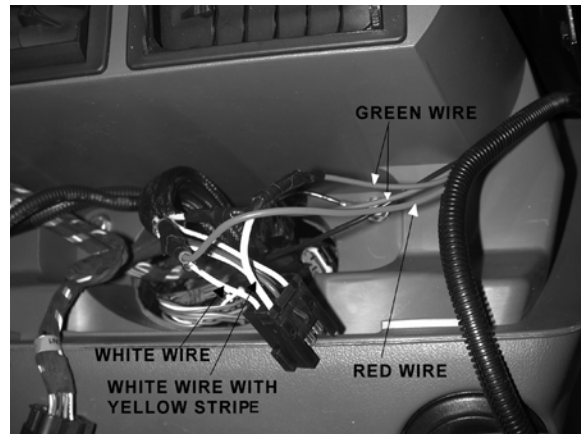

AFTER WIRING



ASSEMBLY

SWITCHBOX WIRING

Power and ground are pulled from the tractor's accessory socket using the keyed hot wire on the supplied plug for power and the black wire for ground. Use a test light to verify whether the red or orange wire is the hot wire (hot when key is in the "on" position).

The switchbox is to be secured to the cable control bracket as shown in the Parts Section.

(ASM-NH-0121 TS6 1XX T4B)



ASSEMBLY

SWAY BAR ARMS

The sway bar arms on the TS6.1xx T4B and Case Farmall A130 tractors need to be repositioned. The sway bar anchor should be rotated 180° on its longitudinal axis to place the pin stowage tang outboard. *(ASM-NH TS6 130 SWAY BAR ARMS)*



ASSEMBLY

LIFT VALVE MOUNTING

The lift valve mounting bracket and plate will be mounted on legs secured to the rear of the axle braces. See the Parts Section for details on mounting information and hardware used.

(ASM-NH-0066 NH T6 1XX T4F)



ASSEMBLY

HOSE ROUTING

The lift valve uses the tractor's pressure, return and load sense ports. The pressure and return ports are located at the rear of the tractor, below the installed lift valve mount. The load sense port is located beneath the tractor cab on the top block. (ASM-NH TS6 1XX T4F HOSE ROUTING)

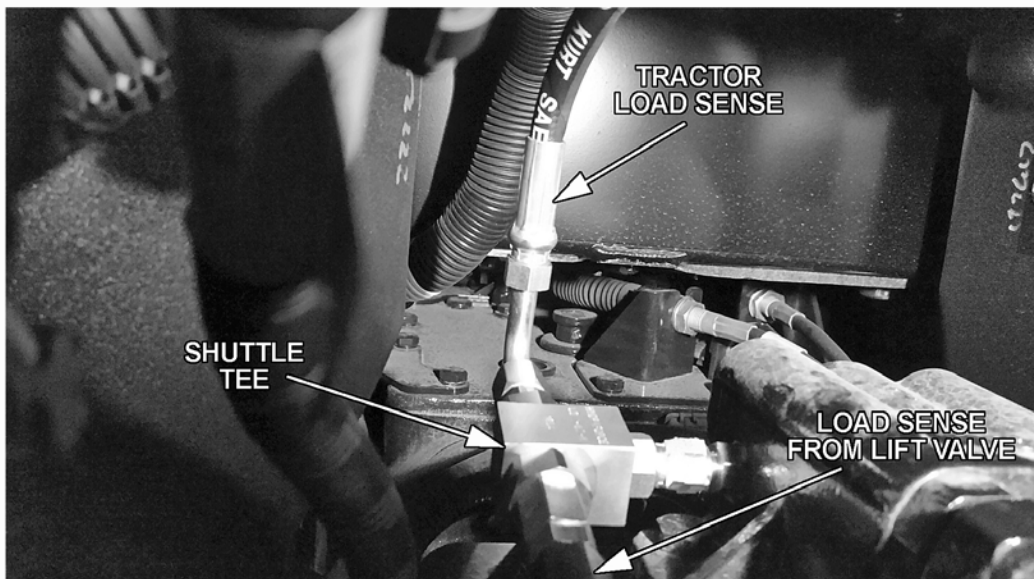
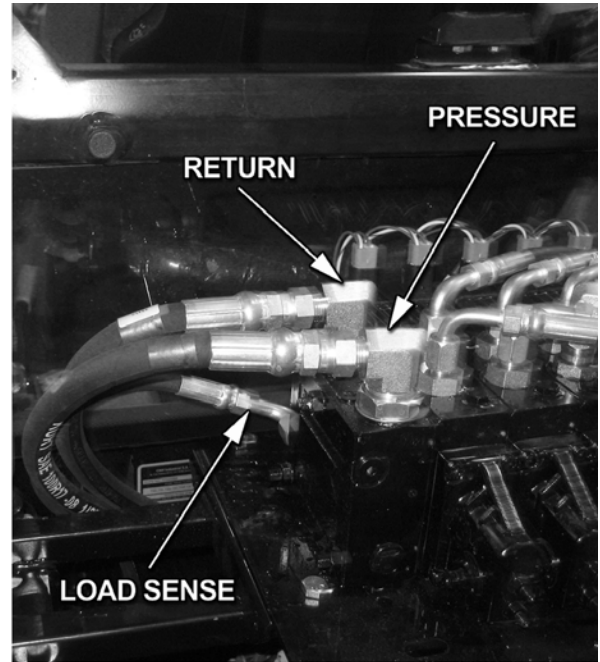
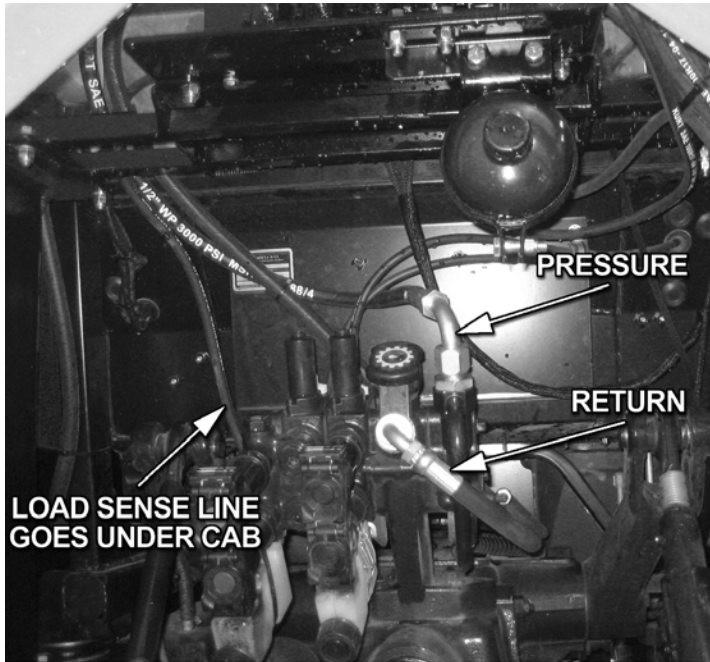

ASSEMBLY

FILLING HYDRAULIC RESERVOIR

Refer to the Maintenance Section for filling specifications and hydraulic oil requirements.

NOTE: Starting or running your Tiger mower before filling reservoir will cause serious damage to the hydraulic pump.

(ASM-C-0004hydro resrv)

INSTALLING O-RING FITTINGS

Installing straight, 45° and 90° O-rings requires that the O-ring and washer be up against the swivel body. Insert the swivel and turn in until the swivel is pointed in the desired direction and O-ring contact is made. Hold swivel in set direction with a wrench and turn the O-ring nut away from the swivel body and carefully tighten. *(ASM-C-0056)*

INSTALLING NATIONAL PIPE FITTINGS

Whenever installing a pipe fitting, wrap the threads clockwise (looking at the end) with teflon tape. In this way, the tape will be tightened when installed. NOTE: It is not necessary to tape O-ring fittings, or those installed in swivels. *(ASM-C-0088)*

GENERAL HOSE INSTALLATION

Refer to the Parts Section for detailed information about hoses and fittings for this application. *(ASM-C-0011)*

SOLENOID BRAKE VALVE

Install a solenoid valve on the mounting bracket with the supplied hardware as shown in the Parts Section in this manual. While installing the fittings to the brake valve, the electrical coil on the spool may have to be removed to make room. When reinstalling the coil, it is important to use no more than 5 ft. lbs. (or 60in. lbs.) torque. **WARNING: OVER TORQUE TO THE COIL WILL RESULT IN HYDRAULIC FAILURE OF SPOOL.** *(ASM-C-0025)*



ASSEMBLY

LIFT VALVE HOSE AND CABLE ROUTING

Attach two clamps to the right rear wheel well for proper hose/cable routing. Drill one hole for each clamp. Use the lower rear corner of the wheel well as an origin for measuring. The holes should be $\text{Ø}10\text{mm}$ or $\text{Ø}3/8"$ reamed to accept $3/8"$ hardware.

Measure from the back edge of the wheel well $13\text{-}1/2"$ from the origin. Use a square to measure $3\text{-}1/2"$ up. Refer to the images below to see the first hole placement.

The second hole should run parallel to the bottom edge of the wheel well. Mark the hole $12"$ from the first hole and $3\text{-}1/2"$ from the bottom edge. Use the images below for reference.

NOTE: DO NOT CUT INTO TUBES / HOSES / WIRES WHEN DRILLING THROUGH METAL OR PLASTIC!

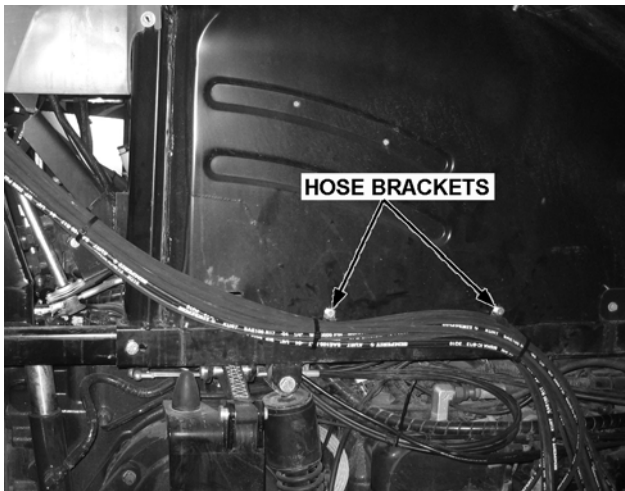

RIGHT REAR FENDER

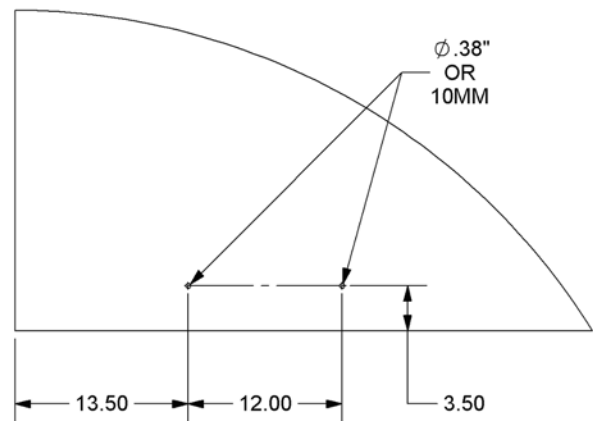

Place as many hoses in the clamp as will fit without compromising pressure. Then secure the (2) HOSE CLAMP (06520013) to the holes drilled with (1 EACH) CAPSCREW, $3/8"$ X $1"$, NC (21630) and (1 EACH) NYLOCK NUT, $3/8"$, NC (21627). The hoses that don't fit into the clamp are to be secured to the others with zip ties. For protection of hoses in contact with metal edges, wrap hoses with split hose sections and fasten with hose clamps or zip ties as needed.

(ASM-NH-0067)



ASSEMBLY

COOLER MOUNTING

Attach the cooler mount to the pump mount using the hardware provided. Attach cooler brackets to the cooler mount and attach the screen and cooler to the brackets. Refer to the Parts Section for details on hardware, hoses and adapters used. (ASM-C-0092a)

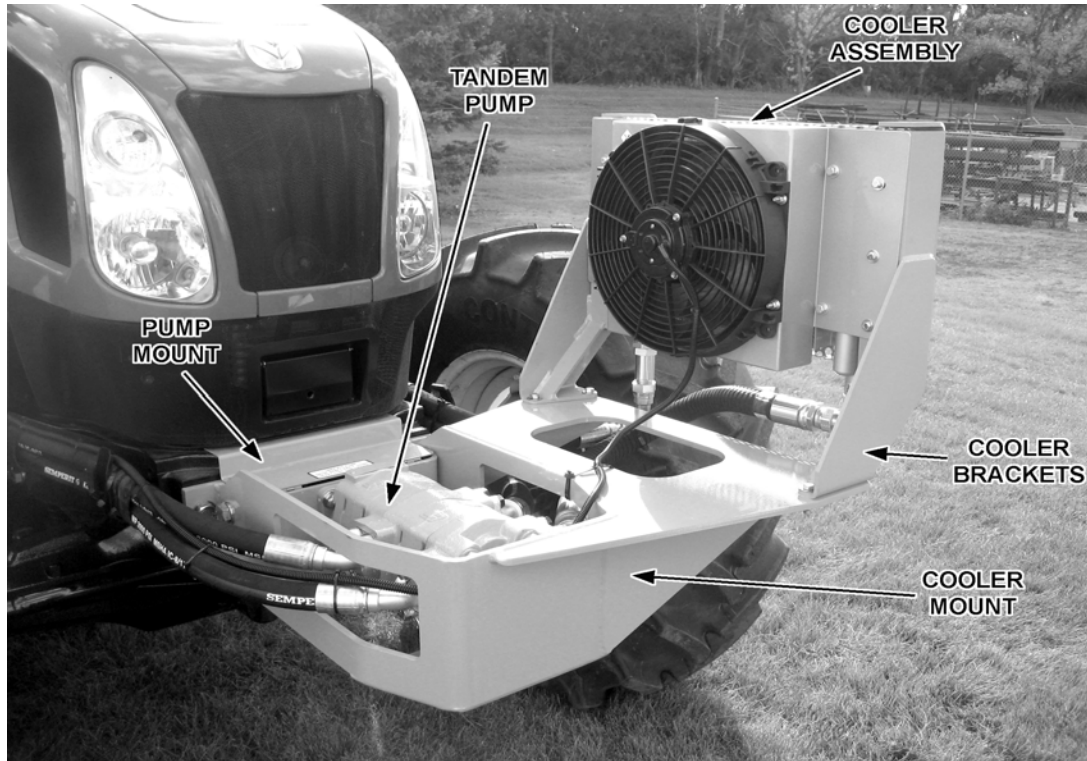

ASSEMBLY

TWIN MOWER HYDRAULIC DIAGRAM

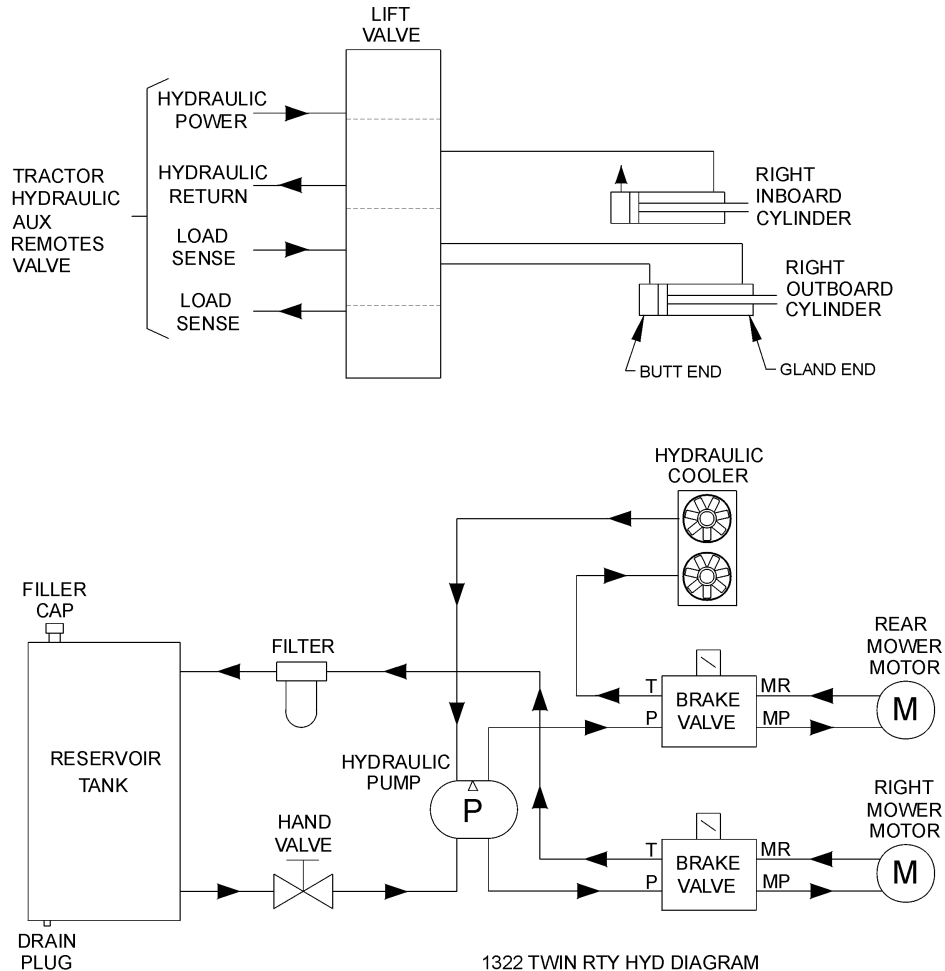

(ASM-C-0095)

WHEEL WELL HYDRAULIC TANK INSTALLATION

Install all fittings and tubes into tank and tank filter as shown in the Parts Section illustration. Insert tank sight glass onto the tractor side of the tank.

Place the tank in the mounting bracket on the axle brace as shown in the Parts Section. Secure the tank with the hardware provided.

Install the filter gauge into the filter housing so that it points to the rear of the tractor and is clearly visible to the operator. The tank breather cap is ready for use as the tank is filled. Some of these items may already be installed. (ASM-C-0103)

TEMPERATURE GAUGE MOUNTING (OPTIONAL)

Mount the temperature gauge where it is clearly visible to the operator. Attach the green (-) wire from the negative post on the gauge to a grounded bolt on the tractor frame. Remove paint if needed to make a good ground. Remove the pipe plug from the side of the hydraulic reservoir and install the temperature sensor using thread sealing tape. Run the white wire from the (s) sensor post of the gauge to the temperature sensor on the hydraulic reservoir tank. (ASM-C-0051)



ASSEMBLY

HOSE COVERING

Secure hoses together with zip ties wherever loose. Wrap the hoses between the main boom and secondary boom with the hose cover provided. Wrap the hoses between the brake valve and the main boom with the hose cover provided. Wrap the hoses between the deck attachment and the secondary boom with the hose cover provided. Where hoses may contact the frame or other edges, wrap with split hose and secure with hose clamps or zip ties. On non-cab units, the pressure and return hoses from the control valve will also need to be routed inside the protective hose wrap. Cover the valve, valve fittings with the hose cover and secure with black string provided.. (ASM-C-0087)

DRAFT BEAM INSTALLATION

Install ½" O-ring breather into butt port of inboard cylinder. Install fittings in the rod end of the cylinder according to the diagram in the Common Parts section. These fittings should be positioned to face the butt end of the cylinder.

Next turn the clevis onto the rod of the cylinder until it is tight against the shoulder and lock into place with locking bolt on clevis.

The inboard cylinder can now be installed into the main frame mast with the pin, flatwasher and R-clip as shown below.

Install all fittings in the outboard cylinder and adjust to point towards the butt end of the cylinder. Attach the hoses as specified in the Parts Section. Slide the cylinder into the draft beam from the outside of the draft beam and attach cylinder to the draft beam with clevis pin and rollpins. (ASM-C-0076)

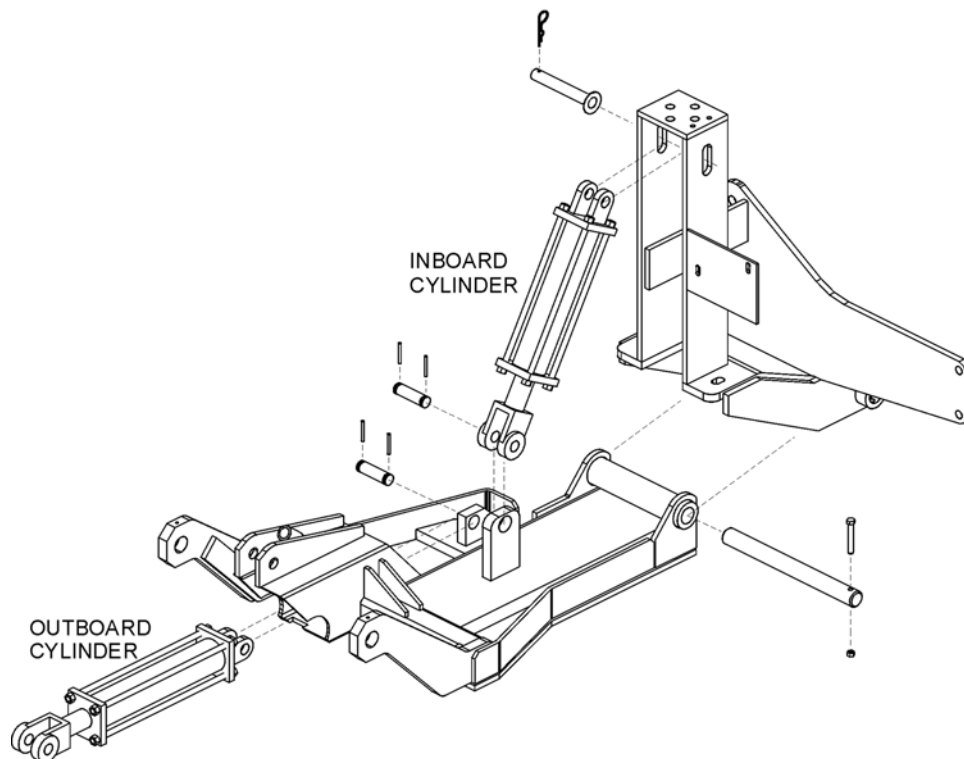

ASSEMBLY

DRAFT BEAM MOUNTING

Pull the inboard cylinder piston rod down to the extreme extended position. Slide the draft beam under the cylinder

Using the inboard cylinder as a pivot point, slide the draft beam under the tractor and install draft beam pin. Align hole in draft beam pin with holes in mainframe boss and install capscrew and nylock nut. (ASM-C-0078)

MOWER MOUNTING

Check that all grease zerks have been installed in the draft beams pivot arm, left linkage arm, right linkage arm, and cylinder mounting ears.

Using a clevis pin and roll pins, connect the pivot arm to clevis on draft beam. NOTE: Make sure the longer distance between the cutout and the end of the pivot arm is closest to the draft beam pivot ears on the center tube as shown in the diagram below. Also make sure the cutout on the pivot arm faces into tube of draft beam. (ASM-C-0077)

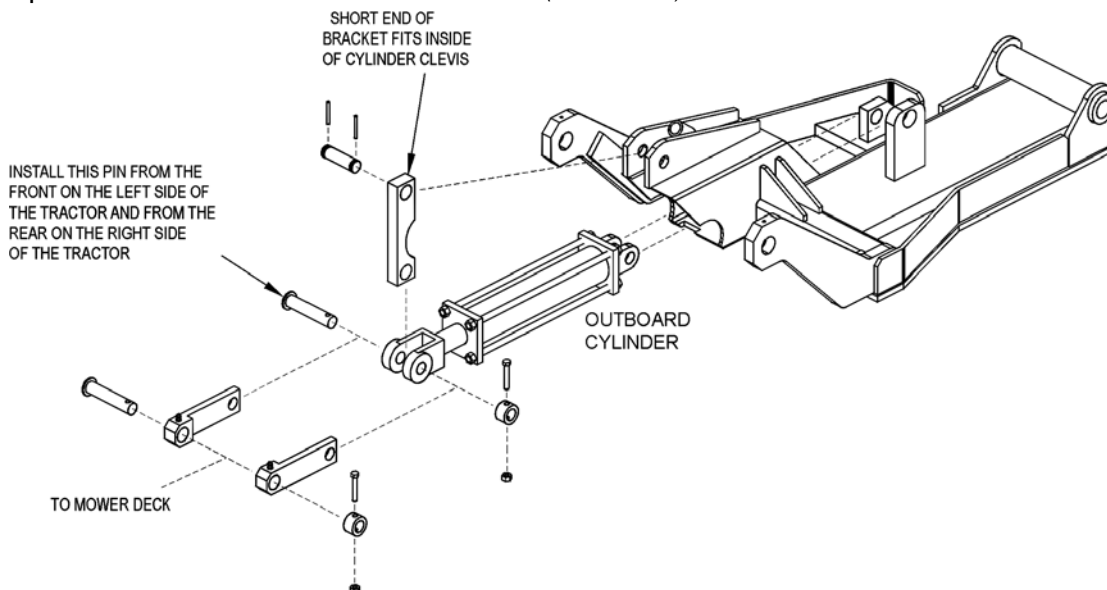

Slide other end of pivot arm with short distance between the cutout and the end of the pivot arm, into the cylinder clevis. Next, line up the holes of the left and right lift linkage arms outside of the cylinder clevis holes. Connect with linkage pin, shims (as required), boss, capscrew, lockwasher and hex nut as shown.

To connect the bonnet to the draft beam, slide the extension arms of the draft beam between the mounting ears on the inner end of the bonnet. Line up the holes and secure with swivel pin, capscrew, lockwasher, and hex nut (both sides). See Parts Section illustration.

Next, slide the left and right linkage arms up to the slotted ear on the side of the deck. Secure with linkage pin, shims, boss, capscrew, lockwasher and hex nut. See illustration in Parts Section.



ASSEMBLY

TWIN ROTARY MOWER INSTRUCTIONS

HOW TO REMOVE REAR MOWER

1. Rest rear mower so ground supports it front and rear.
2. Turn tractor off. There should be no hydraulic pressure in hoses at locations 1,2,3 and 4.
3. Disconnect 2 from 1.
4. Disconnect 3 from 4.
5. Connect 4 into 1.
6. Connect 2 into 3.

CAUTION: DO NOT START THE TRACTOR UNTIL ALL HOSES ARE ATTACHED, TANK IS FILLED WITH PROPER OIL AND BALL VALVES ARE OPEN! STARTING AT THIS TIME WILL CAUSE SERIOUS DAMAGE TO THE PUMP.

CAUTION: NEVER DISCONNECT ONLY 2 FROM 1 WITHOUT CONNECTING 4 INTO 1. CATCH AND CONTAIN ANY HYDRAULIC OIL WHEN DISCONNECTING FITTINGS.

(ASM-C-0033)

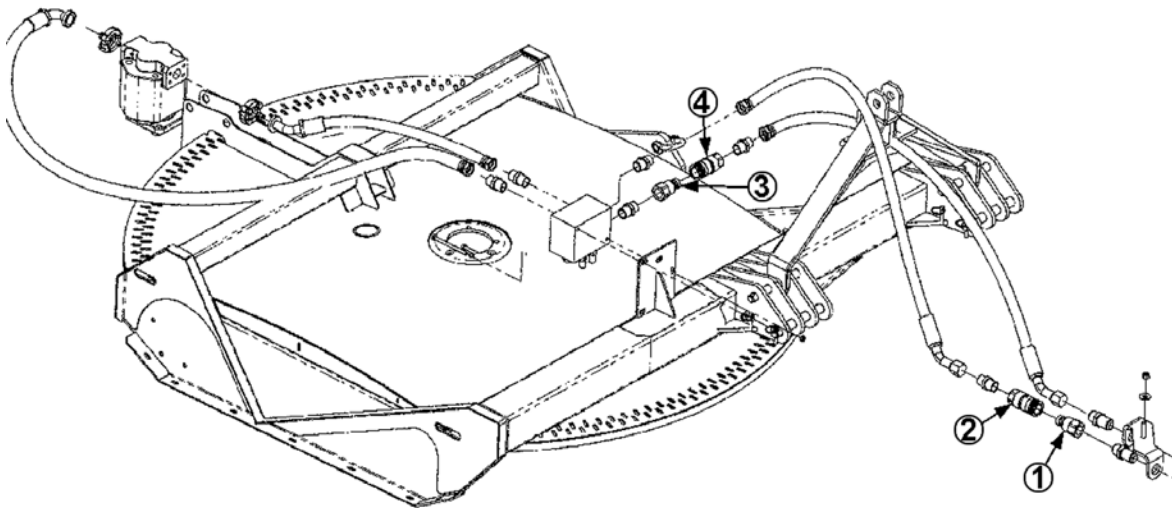

=



ASSEMBLY

3-POINT DECK TILT CYLINDER

Remove the lift rod from the left rear 3-point arm and replace with the cylinder, clevis ends, and pin furnished in the kit. See Parts Section for parts and assembly.

(ASM-3-PT DECK CYL-0001a)

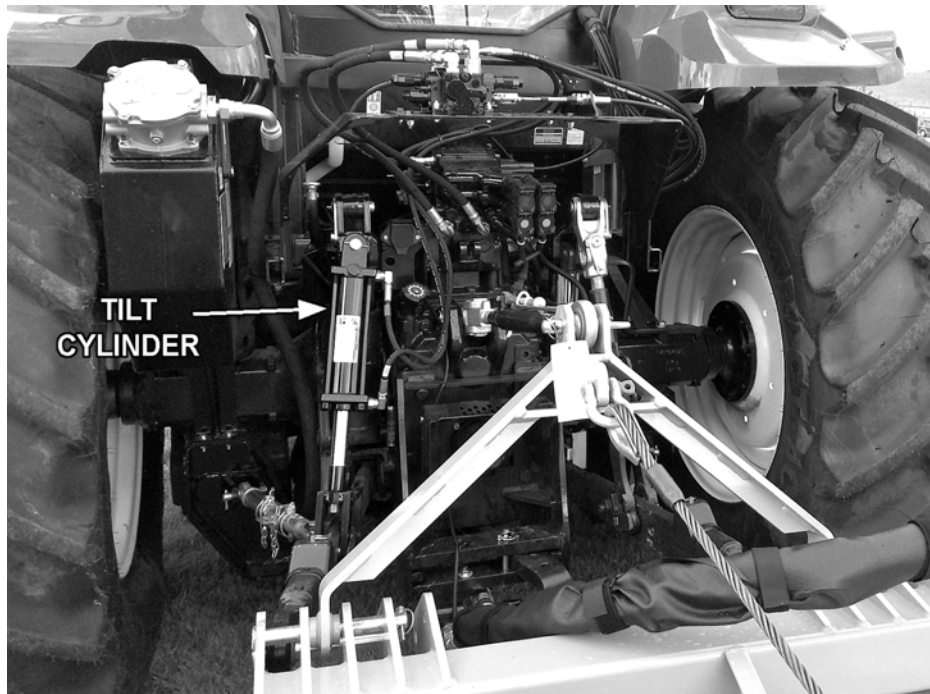

ASSEMBLY

WEATHER-PACK / METRI-PACK ASSEMBLY

These instructions apply to both Weather-Pack and Metri-Pack connectors.

NOTE: Use the specific tool for the type of connector you are assembling.

(ASM-C-0009)

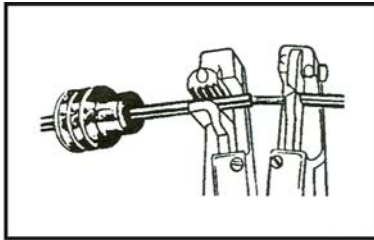

1. Apply seal to cable, before stripping insulation.



2. Align seal with cable insulation.

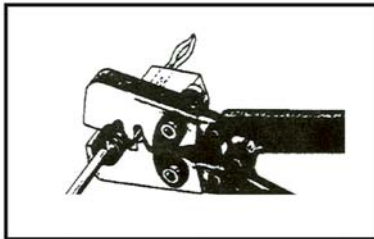

3. Put terminal in crimping tool, then position wire and seal in place.

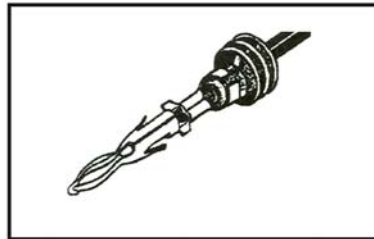

4. Crimp and visually inspect for a good crimp before installing in connector body.



ASSEMBLY

FINAL PREPARATION FOR OPERATION

Place operator's safety and operation decals on the steering column and side console where they are clearly visible to the operator. These decals should be understood by each operator of the machine in conjunction with the Safety and Operation Sections of this book. The decals are to be maintained in good condition as a reminder to the operator, and should be replaced if damaged.

All bosses, pins and pivot points will need to be greased as instructed in the Maintenance Section of this manual. The hydraulic reservoir can also be filled with the recommended fluid (see Maintenance Section) and the filter installed in the top of the tank. Double check all fittings and fasteners **BEFORE** starting tractor. Also secure any loose hoses together with zip ties and wrap with split hoses where friction may occur on the hoses.



BEFORE starting or operating the tractor you must read and understand the Safety and Operation Sections of this manual completely.

BE SURE THE BALL VALVES ARE OPEN! Start tractor and allow instruments to stabilize. Using a piece of paper or cardboard as noted in the Safety and Maintenance Sections, check all fittings and connections for hydraulic leaks.

If a leak is found, you must shut down the tractor and set the cutter on the ground. Before attempting to fix the leak, you must actuate the lift valve handles several times to relieve any pressure in the lines.

Before operating the mower, the cutter head and boom should be slowly moved throughout the full range of motion. Watch for any condition that would cause pinching or excess stress on the hoses. The steering and front axle travel should also be carefully moved through their full range of motion. If any condition occurs in which the hoses contact the tires, the steering and / or front axle travel may need to be limited as described in the tractor operator's manual. This should also be done if the tires rub, or are extremely close to any other part of the mower, such as the hydraulic tank or draft beam. This may include adding shims or adjusting stop bolts in the tractor front to solve the problem. While checking motion, you should also check that the control circuits are connected according to the operator's decal for the valve handles.

MOWER TESTING

Take the tractor to a place free of loose objects on the ground. Operate the cylinders through their full range of motion again, to clear the lines of air. Follow the instructions in the Operation Section to operate the mower. Vibration of the mower should be minimal at all times. After a 5 minute test run, the knife bolts should be retorqued, and retorqued once again after the first few hours of operation.

If any parts of this Assembly Section, or any other section of this manual are not clearly understood you must contact your dealer or the address on the front of this manual for assistance!*(ASM-C-0010)*



CD9 F 5 HCB' G9 7 HCB

UJ ^!aa } A^&a } A.E

CD9F5HCB

CD9F5HCB

+ "%Hf UWcf 'DfY!CdYfUjcb`-bgdYWjcb#GYfj JW

Ü^A|Ä Ä@Ä:æd|Ä| |æ |q Ä æ` æÄ Ä) • |^Äæ
 &| } |^cÄ |^E | |æ } Ä • |^&Ä } Ä äÄ &@ä` |ä
 • |çæ^Ä Ä | | | |^ Äæ&| |äq * Ä Ä@
 { æ` æc | |^ • Ä^&| { |^ } äæ } • EÄV@Ä | | | , q *
 æ^Ä | { |^ Ä Ä@Ä | | • Ä@Ä^` ä^Äæ Ä |çæ^Ä ä
 ä • |^&Ä } K



Op-13

- " VÄ^Ä| } äæ } EäÄ |^••` |^
- " Y @^|Ä` * Ä | |^ Ä
- " Üc^|ä * Ä | æ^
- " ÚVUÄ @ |äÄ
- " ÚT XÄ ä | Ä^Ä|æ } Ä äÄæ ä |^
- " V:æd | q Ä @ Ä^Ä|æ } Ä äÄ } &Ä } æ
- " V:æd | Ä^æÄ |^Ä Ä Ä | | Ä| } äæ } Ä
- " V:æd | ÄUUÜÄ Ä Ä | | Ä| } äæ } Ä
- " ÜUUÜÄ Ä Ä @ Äæ^ äÄ | • äæ }
- " P | Äæd | Ä äÄæ • Ä
- " Üæææ | Ä^Ä Ä^ä | ä
- " Ö) * ä Ä äÄ^Ä | Ä äÄ | } äæ }
- " Ö) * ä Ä | | äÄ^Ä | Ä äÄ | } äæ } Ä
- " Ü | , |^Äæ^Ä | äÄ^Ä | Ä
- " Ü | , |^Äc^|ä * Ä | äÄ^Ä | Ä
- " Ø^Ä | } äæ } Ä äÄ^Ä | Ä
- " Ü` -æ } Ä | äæ } Ä^Ä | äÄ | ä •
- " ÖÄÄc^Ä | } äæ } ÄOPS-U-0030

+ "&A ck Yf 'DfY!CdYfUjcb`-bgdYWjcb#GYfj JW

Ö^ | |^ÄæÄ | , |^Ä • |^Ä | | | |^cÄ | |^&Ä } Ä äÄ |çæ^Ä Ä^Ä` ä^ÄÄ Ä) • |^Ä@Ä | , |^Ä Ä ÄÄ | | äÄ ä
 • æÄ | | | q * Ä | } äæ } EÄV@Ä æ^ÄÄ äÄ | Ä | | | Ä æ • Ä @` |äÄ^Ä^ } ä^ÄÄ äÄ | Ä | | æ^ÄÄ { |^æ | EÄV
 ^) • |^Ä@Ä | , |^Ä Äæ^Ä | | | |æ } EÄ | } ä` &Ä@Ä | | | , q * EÄOPS-R-0007



U^|ä äæ | Ä • |^&Ä | Ä | çä * Ä æ • Ä | Ä^æÄ äÄ | |æ^Ä @ }
 } ^&••æ^Ä äÄæ c | ä^Ä |çæ^Ä ä • EÄ | | Ä | Ä | | • Äæ c } |^ • EÄ | |
 | | Ä | | ^ } Ä æ • EÄ äÄæ^Ä | Ä | | • ÄÄæ * • EÄ æ^Ä |^Ä | Ä q • Äæ^
 ææÄ@ * Äæä, æ^ÄU^|ä` • Ä b |^Ä æ Ä &Ä | Ä | { Ä | Ä æ æ ä * Ä@
 { æÄ^Ä Ä | | äÄ | | | q * Ä | äÄ | | EÄV@Ä



CD9F5HCB

CD9F5HCB

V@Á] ^|æ[i q Á æ ~ æ Á æ á Á æ ^ Á æ } • Á æ ~ á Á }
 c@Á } á Á } æ Á } [| cæ } á • d ~ & cæ } • Á } Á @ Á æ
 æ á Á : [| ^ Á • ^ Á Á @ Á ~ á { ^ } d Á æ æ æ Á @ • ^
 á } [| cæ } á æ ^ Á æ : ^ Á } Á @ Á }] | { ^ } á Á [| á
 & } á á } Á Á } • ^ Á @ Á } [| { æ } Á Á æ æ æ ^ Á Á
 c@Á] ^|æ[: Á Á Á Á ^ • É

" Ö) • ^ Á Á æ ^ Á æ } • Á æ Á Á | æ Á Á æ á Á * æ | É
 Ü] | æ Á Á { á • á * É á æ æ ^ á É æ á Á | ^ á |
 á ^ æ É OPS-U- 0011_A



Op-14

NOTE: The mower Operator's Manual and affixed Decals contain important instructions on the safe and proper use of the mower. Maintain these important safety features on the mower in good condition to ensure the information is available to the operator at all times.

ÖÜÆ ÜÜÜÜÜÜ ÜÜÜ

" Ö) • ^ Á Á æ } á á } Á Á [~] æ * Á æ ^ Á | á { ^ } d
 " Ö) • ^ Á Á æ } á á } Á Á æ ^ Á Á { á | É
 " Ö) • ^ Á Á Á | cæ } á Á & ^ , • Á æ Á Á [• á á } Á æ á
 æ Á Á [| ^ | Á Á | ~ ^ á É
 " Ö) • ^ Á Á á • Á æ Á Á | | æ Á Á æ á Á æ c ^ á Á æ @
 • & ^ • É
 " Ö) • ^ Á Á æ ^ Á Á Á [| ^ | Á Á [~] c á Á c Á c æ d |
 æ á Á c æ á , æ Á á Á : [| ^ | Á á • æ ^ á Á æ á
 cæ @ ^ á á É OPS-R-0099



Ops-1250

WARNING

Ü | æ c ^ Á @ á | æ | æ Á | ^ • • ^ Á | á | Á Á | á * Á æ ^ Á æ c } æ & Á | Á ^ } æ Á [| Á } Á @ Á Q] | { ^ } d
 Ü | æ Á @ Á [^ | Á ^ æ Á } Á @ Á | ~ } á Á | Á & ^ | Á ~] [| c á Á } Á [& • Á | Á æ á • É á ^ } * æ ^
 c @ Á Ü V U É æ á Á : } Á Á @ Á } * á ^ É Á • cæ á Á ~ | Á @ Á } d [| Á c ^ | • Á | Á ^ • cæ Á ^ c ^ á Á Á ^
 d Á | æ c ^ Á | ^ • • ^ Á | á | Á Á cæ cæ * Á æ ^ Á æ c } æ & Á | Á ^ } æ Á [| Á ÜÜÜÜÜÜ ÜÜÜ

WARNING

Þ ^ c ^ Á Á æ { } c Á Á á | æ Á Á • d Á | Á ^ [c ^ Á æ | æ Á | { Á @ Á Q] | { ^ } c Á @ Á Á Á Á
 { | cæ } Á | Á @ Á Á cæ d | Á } * á ^ Á Á ~ } á * É ÜÜÜÜÜÜ ÜÜÜ

VY Ö ÜÜÜÜÜ ÜÜÜ

U] ^|æ[Á Á & cæ } Á Á É F

CD9F5HCB

CD9F5HCB

PYOUNSODASQOAPUOOVQJ

“ Ô@&Á ¶|Á @á|æ |æÁ |æ•Á æ¶ }*Á @••É
 &|á á^!•Áæ áÁæ¶ *É =A DCFH5 BHÁÖUÁUV
 ~•^Á [~|Áæá •Á¶ Á&@& Á¶|Á ¶Á^æ •ÉÁV^Áæ
] æ&Á -Á@æ¶ Á æ¶|Á |Áæáà| æáÁ¶ Á&@& Á¶|
 @á|æ |æÁ ¶Á^æ •ÉÁ
 “ Q•] ^&Á@Á¶ } áæ¶ } Á -Á@Áæ¶^Á ^|á (^) É
 “ Ö)• ^Áæ¶ *Á Á[] ^| | Á¶ } ^&cá
 “ Q•] ^&Á¶ } áæ¶ } Á -Á • @ *É OPS-R-0100_A



WARNING

Ö| Á [Ö] ^|æ Á@Á Ö ~ á { ^ } Ö á@á|æ |æÁ ¶Á |Á^|Áæ á * ÉÁUá
 æ áÁ^ |Áæ^Á¶ [] • æ^Áæ áÁ@á¶ |Á^ } &Á¶ |áÁ |Á^ } ÖÁææ áÁÖÖ|
 } [Ö&@& Á¶|Á^æ •Á æÖÁ [~|Áæá áÁ¶ á Ö] ^•• |Á¶ áÁd^æ •Á [{
 à^æ •Á Á@Á¶ ^Á¶ |áÁ^ } ^dæ^Á@Á | á Áæ áÁæ^•Áæ ~^Áæ æ^
 á &| áá * Á æ * | ^ } ^ÉÁV | Á&@& Á¶ | Á@ • ^Á^æ ÉÁPWÁ@Á } áÖPÖÖÖ
 UÖÖÁæ áÁ^ [ç^Á¶|Á@á|æ |æÁ |Á^•• |ÁÉÁV ^æÁ áÁ] ^ } ^dæ|Á [ç^É
 •æ^ç Á |æ •• Áæ áÁ • ÁÖæáà| æáÁ¶ Á&@& Á¶ |Áçæ^ } &Á -Á ¶Á^æ •ÉÁ
 ^ [~ Á •] ^&Áæ^æ ÉÁÖT UXÖÁ@ÁPUÖÖÁæ áÁæ^Áæ • ç^áÁæÖÁ^É
 Ö| áÁ [^•Á^ } ^dæ^Á@Á | á ÉÁæ^Á@Á b | Á^æ^áÁ { ^áæ | Á^ Áæ
] @ • æá Á [] , |á^æ^Áæ áÁ | áÁ^Á@Á | [&á^ | Á^ÉÁÖÖÉí D



VY ÖÁUVÖÿ

U] ^|æ¶ } Á^&¶ } ÁÉG

CD9F5HCB

CD9F5HCB

YOU OWN THE MOWER

- Read the manual before using the mower.
- Always use proper mowing techniques.
- Never drink or use alcohol while operating the mower.
- Always use proper safety procedures.
- Always use proper maintenance procedures.



Ops-1235

Read the manual before using the mower. Always use proper mowing techniques. Never drink or use alcohol while operating the mower. Always use proper safety procedures. Always use proper maintenance procedures.

OPS-R-215

WARNING

Read the manual before using the mower. Always use proper mowing techniques.

Never drink or use alcohol while operating the mower. Always use proper safety procedures. Always use proper maintenance procedures.

WARNING

Read the manual before using the mower. Always use proper mowing techniques. Never drink or use alcohol while operating the mower. Always use proper safety procedures. Always use proper maintenance procedures.

CD9F5HCB

CD9F5HCB

ÜUVÖÿÁÒÖÖÁÐÙÚÖÖVÖÞ

- " Q•] ^&0À|ææ^•Áæ} àÀ|ææ^Áæ| |ø ÁÏ !Á| [•^)^•• æ} àÁç&•• æ^Á^ æËÙ| æ^ÁÏ ÁÏ»ÁÏ Á æ^ÁÏ ! &@& ã * Á^æ æ|ËÁÙ^| æ^Ááæ æ^áËÁ, [!] È æ} àÁ{ æ•ã * Áà|ææ^•Áæ Á& [] |ø Á^•ø Áç { æ} æ} Á| æ^ Áææ} &È
- " Ö)~ !^Áà|ææ^Á&æ| æ|Á| Á)~ ø Áæ^Áç !~^ áÁç]!| ^!Á| ^&æææ} •È
- " Ö)~ !^Á^ àà^!Á^ ^&ç !• Áæ^Áç Á| [•æ} Áæ} à }| øáæ æ^áËÁÙ^| æ^Á, [!] È à| \^| Èæ} à { æ•ã * Á^&ç} •Á { ^áæ^ È
- " Ö)~ !^Á@ á|æ |æÁ^• Áæ^Á| [] ^!| Á| } ^&ç á ç Á@Á@ á|æ |æÁ| [ç |È Ö@& ÁÏ !Á@ á|æ |æ |æ •Áç| } * Áç^• Áæ} àÁææ * È ÖÙÁÙVÁ^ ^ [~ !Áç} à ÁÏ &@& ÁÏ !Á çÁæ •ÈV^ Áæ} æ& [Á@æ^ Á] æ^!Á| !Á&æ àà| æáÁç Á@& ÁÏ ! @ á|æ |æÁ çÁæ •È
- " Q•] ^&0ø ÁÏ| áææ} Á Á& Á| æÁ ç^• Áæ} àÁçæ, æ^ È OPS-R-216



WARNING

O[Á [ç] ø ç} à Á | Á^ Á } á^! Á [, ^! Á& • È Ö| æ^ Á Ö| } æ& ç} Á^ ~ | ç ã Á^! ç ~ • Á ç |^ Á | Á ç^} Á^ æ ç È Ö ç} Áæ æ Á } ç Á ç | Á [ç } Á ç Á ç]] ^ á æ} à Á ç Á& • Áæ^ Á^ & !^ | Á | [& ^ á Á] È Á Ç Ö T È È J D



CD9F5HCB

CD9F5HCB

Blade Damage

OPS-U-0031

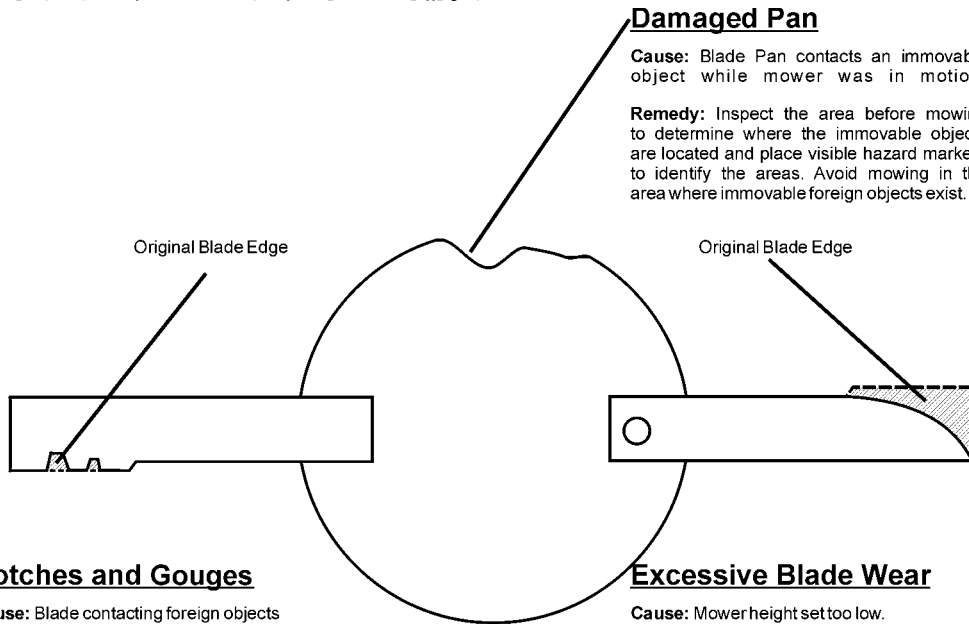

Damaged Pan

Cause: Blade Pan contacts an immovable object while mower was in motion.

Remedy: Inspect the area before mowing to determine where the immovable objects are located and place visible hazard markers to identify the areas. Avoid mowing in the area where immovable foreign objects exist.

Notches and Gouges

Cause: Blade contacting foreign objects

Remedy: Inspect the area to be mowed and remove foreign objects that could cause damage to the blades

Excessive Blade Wear

Cause: Mower height set too low. Blade used past intended life.

Remedy: Replace blades more often. Adjust mower height for mowing conditions to eliminate blade-to-ground contact

Op-22



Replace blades in pairs after no more than 1/2" (12.7mm) wear

- " 1. Inspect the blade for damage before mowing.
- " 2. Do not mow over rocks, sticks, or other hard objects.
- " 3. Adjust the mower height to the recommended setting.
- " 4. Replace blades in pairs after no more than 1/2" (12.7mm) wear.
- " 5. Always use proper mowing techniques.

Replace blades in pairs after no more than 1/2" (12.7mm) wear



1/2" MAXIMUM
(12.7mm)

Original Blade Edge

NOTE:
Replace Blades in pairs after no more than 1/2" (12.7mm) wear
Op-23

CD9F5HCB

CD9F5HCB

Excessive Blade Bolt Wear

Q.] ^&@Á|æ^Á| |óP^æÁæÁ Á|!Á ^æÁæ Á| || , ^áK

Cause: Blade Bolt contacts a foreign or solid object while Blade is in motion.

Remedy: Inspect the area before mowing to determine where the foreign objects are located and place visible hazard markers to identify the areas where immovable foreign objects exist, and avoid hitting the objects.

Notches and Gouges

Cause: Blade Bolt contacting foreign objects.

Remedy: Inspect area to be mowed and remove foreign objects that could cause damage to the blade bolt.

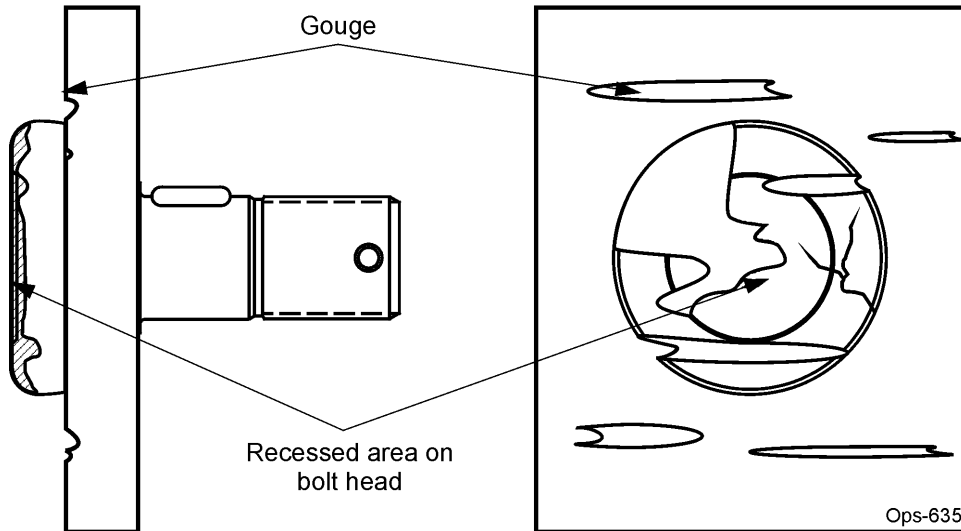

⚠ DANGER

Q.] ^&@Á|æ^Á| |óP^æÁæÁ Á|!Áæ} [!| æÁ ^æÁÛÒÚŠÓÈÒÁÚ VP ÁÓŠÓÈÒÁÚ ŠVÙÁ }
 @Á|æ^Á Á T ÖÖVÖŠÝÁÁæ@Á|æ^Á| |óÁæK

- ~ Xā ā| ^&æ. Á|Á
 - ~ Q@Á&••^áæææ } Á|æ^Á| |óÁ [!| Á-Á|Á
 - ~ QÁ|æ^Á| |óæ Á| ^*^Á|&æ] ^áæææ É
- Qæ~!^Á| Á|æ^Áæ} [!| æÁ [!| Á|æ^Á| |óÁ æÁæÁ| Áæææ d[] @Áæ~!^Á-Á@Á|æ^Áæ áÁ|æ&æ } Á-
 @Á| [\^ } ÁæÁ } @Áæ æÁæ•^Á|æ~•Á| áá Á| Á| Á|ææÉ

5'k Ung'fYd'UW'6`UXY6c`lg'k]H `bYk `Vc`lg'k \ YbYj Yf'fYd'UW]b[`H Y6`UXYg"ÁOPS-U-0037

VY QÁUVÖÿ U] ^!ææ } Á|&æ } Á|ÉÍ

CD9F5HCB

Tractor PRE-OPERATION Inspection



Mower ID# _____ Make _____

Date: _____ Shift _____



WARNING 6 YZ:fY Wc bXi Wj b['H Y] bgdYWj cbž a U_Y gi fY'H Y'fUWcf 'Yb[]bY'jg'cZZU''fcUjcb \ Ug'gfcddYX'UbX'H Y'fUWcf 'jg'j'b'dUf_'k]H 'H Y'dUf_]b['VfU_Y'Yb[U] YX''AU_Y'gi fY H Y'a ck Yf 'jg'fYgh]b['cb'H Y[fci bX'cf'gYW fY mV'cW_YX'i d'UbX'U''\ mXfUi 'jW dfYggi fY\ Ug'VYyb'fY]j YX"

| Item | Condition at Start of Shift | Specific Comments if not O.K. |
|--|-----------------------------|-------------------------------|
| The flashing lights function properly | | |
| The SMV Sign is clean and visible | | |
| The tires are in good condition with proper pressure | | |
| The wheel lug bolts are tight | | |
| The tractor brakes are in good condition | | |
| The steering linkage is in good condition | | |
| There are no visible oil leaks | | |
| The hydraulic controls function properly | | |
| The ROPS or ROBS Cab is in good condition | | |
| The seatbelt is in place and in good condition | | |
| The 3-point hitch is in good condition | | |
| The drawbar pins are securely in place | | |
| The PTO master shield is in place | | |
| The engine oil level is full | | |
| The brake fluid level is full | | |
| The power steering fluid level is full | | |
| The fuel level is adequate | | |
| The engine coolant fluid level is full | | |
| The radiator is free of debris | | |
| The air filter is in good condition | | |

Operator's Signature: _____

DO NOT OPERATE an UNSAFE TRACTOR or MOWER

V@AQ•^&ā}AQ|{ Á æÁ^Á^Λ^ Á~|Bæ^áÁ!Áccā&|ā•È

VY Q ÄÜVOCËÿ

U] ^!æā}Á^&ā}ÁÈï

CD9F5HCB

CD9F5HCB

Rotary Mower PRE-OPERATION Inspection



Mower ID# _____ Make _____
 Date: _____ Shift _____



WARNING Read the operator's manual before operating the tractor. The tractor is designed for use only as a tractor. Do not use the tractor for any other purpose. The tractor is not to be used for transport. The tractor is not to be used for any other purpose. The tractor is not to be used for any other purpose.

Table 1:

| Item | Condition at Start of Shift | Specific Comments if not O.K. |
|--|-----------------------------|-------------------------------|
| The Operator's Manual is in the canister on the mower | | |
| All safety decals are in place and legible | | |
| The hitch connection bolts & pins are tight | | |
| There are no cracks in hitch | | |
| The hydraulic cylinders pins are tight | | |
| There are no leaking or damaged hoses | | |
| The mower deck is clear of cut grass and debris | | |
| Chain guards/deflectors are in place & in good condition | | |
| Blade carrier retaining nut is tight | | |
| Blades are not chipped, cracked or bent | | |
| Blade bolts are tight | | |
| Wheel lug nuts are tight | | |
| Transport locks are in good condition | | |

Operator's Signature: _____

DO NOT OPERATE an UNSAFE TRACTOR or MOWER

CD9F5HCB

CD9F5HCB

CD9F5HCB

+) 'GRUHL' 'H YFUWcf

V@A[| &a~ | ^A A@a A@a A@a | A A [a^A] ^&a A
 U^A|A A@A@a A|] ^a A q A a ~ a A | A@a *
] | &a~ | ^A | A | ^A | A@a | a A@a | E O [] ~ | a
 a c | a ^ a ^ a ^ a | A @ A@a * A | | &a~ | ^A
 ~) & a a A |) . ~ | ^A @ A | [a O] d | | A c | A A A @
 | | , ^ | a A [. a] A a A @ A V U A A A ^) * a a A A ^ | ^
 • a a * A @ A@a | E OPS-U-0033



Op-24



U@a A@a | A |] ^ | A |] |] ^ | ^ a a A A @ A | a a | A ^ a a A@a * A
 d a a | A A a A A A . ~ | a A B | ^ A | A a a A @ A | a a A | A |] ^ a | .
 { a ~ a A | A |] | ^ A@a * A . d & a } • E



+ '6fU YUoX'8 IZyfYbH' @W'GYHbl

T a a ~ | ^A @ A@a | A | a ~ A A A [[a A] ^ | a a *
 & |] a a } E V | a a | A | a ~ A a A ^ a A ^ | ^ | ^ |
 a a ^) a) d ^ a | , a * A a * | ^ A a A @ | A | a a a *
 a a } A | A | & a A ~ ^ @ | A | A | [c a A a ~ | a a | ~ .
 | ^ a A @ | A | a a * E A U U A T U U V A U Q U O A U O
 U U O U U A U P O U W P U E V P O A U U C S O A U O C S U
 U P U W S O A O A U O S O O A U O O V P O U A U A U U X W O
 V P O A T U U V A U O Z O V Q O A O U C S O A U O V P A



Op-25

OPS-U- 0013

VY @ A U V O E Y

U | ^ | a a | A ^ & a | A E

CD9F5HCB

CD9F5HCB

+ " F Uqlbl 'H YAck Yf

W`q`A`@`A`a`d`i`A`E` [`q`A`@`E` } d [i`A`c`i`E`a`a`^`
 c`@`A` [, `^`i`A` -`A`@`A`i` [`~` } a`a`a` [`o`A`E`i`A`o`A`@`A`
 ^` [`~`*`@`A`A`^`a`a`a`^`A`i` [`~` } a`A`a`o`a`a`^`E`
 OPS-R-0042_A



+ " '8 f|i|bl 'H YHfUWcf'UbX`a d`Ya Ybh

Ú`a`o`f` -`A`i`q`a` *`A`e`A`A` [, `A`] ^`a`a`a`a` a`A`i`a`a`^` a`f`A`&`^`e`^`A` [`~`i`A`] ^`a`A` @`^`A` a`a` a`a`q` *`A`i` { } |`^`c`^`i` } d [i`A` -`A`@`
 d`a`d` [i`a` a`A` } a`E`A` [`c`a` *`A` [, |`^`e`A`A`o`A` a`l`^`e` [`A`i`^`c`^`] o`A`@`A`i`a`d` [i`A` [{ `A`^`a`a` *`A`] A`a` a`A` [•`^`A` -`A`c`^`i`a` *`A`i` } d [i`E`
 V`@`A`i`a`d` [i`A` @`~` |`a`A`^`c`^`i`A`^`A`] ^`i`e`^`a`A`^`A`] ^`a`a`•`A`@`e`A`e`a` [] o`A`^`A`e`^`i`A`e`a` a`l`^`a`A`i`A` @`E`@` a`l`A`i`^`c`^`] o`A`@`
 [] ^`i`a`d` [i`A` [{ `A`d`]] a`*`A`~` a`l`^`a`i`a` *`A`e`A` { `^`i`^`^` } &`E`A`@`A` [, ^`i`A`c`^`i`a` *`A`i`A`] *`a`^`A`e`^`e`^`A`] ^`i`a`a` *`E`a`d` []
 c`@`A`i`a`d` [i`A` { `^`a`a`e`^`i`A`e`A`o`A`i`a`d` [i`A` a`l`^`a`^`a`e`^`a` |`o`A`A`i` } d [i`E`

Ú`i`-`i` { `A`c` } •`A` a`o`A`@`A`i`a`d` [i`a` a`A` } a`e`A`A` [, `A`] ^`a`a`•`A`i`A`c`^`i` { `a`^`A`@` , `A`@`A`i`a`d` [i`A` a`o`A`e`A`e`a`e`@`a`A` [, ^`i`
 @`e`a`l`^`•`A`A`c`^`i` } E`A`O`^`c`i` { `a`^`A`@`A`e`^`A`] ^`a`a`A`i`A` a`a` a`a`A`i` [] ^`i`A`i` } d [i`A` -`A`@`A`i`a`d` [i`A` @`] A` a`a`q` *`A`c`^`i` } •`E`A`O`E` [,
 a`a`i`a`a` } a`e`A`^`e`e`e` &`A`i`A`@`A` } a`A` @`] A`c`^`i` } a`*`E`

V`i`A`e` [a`A`c`^`i`c`^`i`] •`E`A`i`q`^`A`@`A`i`a`d` [i`A` a`o`A`e`A`e`a`a`a`e`A`a`e`A`] ^`a`a`•`E`A`] ^`e`a`f`^`A` @`] A`] ^`i`a`a`q` *`A`c`^`i`A`i` [`~`*`
 *`i` [`~` } a`E`E` [•`a` *`A`a`e`@`A`i`A` [] ^`•`E`a`e`a`c`^`i` } a`*`A`i` { } ^`i`E`A`i`a`d` [i`A` @`^`i`A`^`a`a`A`] a`a`a` *`A`@`~` |`a`A`^`A`e` &`^`e`^`a`
 , @`] A` [i`i`q` *`A`] A`&`q`^`•`A`i`A`i` [`~`*`@`i` [`~` } a`A`A`a`^` &`A`o`A` [•`a`a`a`c`^`A`A`] a`*`E`

W`^`A`c`d`^` { `^`&`e`c`q` } A` @`] A`] ^`i`a`a`q` *`A`] A`c`^`i`A` [] ^`•`E`S`^`] A`o`A`i`a`d` [i`a` A`a`i` , A`^`a`A` @`] A` [a`*`A`i` , } @`i`E`A`O`U`
 P`U`V`A`e` a`e`o`f`i`A`^`^`E` @`^`i`A` [, } @`i`E`A`O` OPS-U-0014_A

+ " '7 fcgqlbl '8 IHW Yg'UbX`GHYd`bWlbyg

Y`@`] A`i` [•`a` *`A`a`e`@`•`A` a`o`A`c`^`i`] A`a`e` \`A`i`A` [a`*`A`]
 •`@`e`] A`&`q`^`•`E`A`i`A` [•`a`i`^`A`c`e`A`@`A`i`a`d` [i`A`E` [a`c`
 a`e` { `A` a`e`A`i` { `A`~` E`A`V`@`A`] ^`A` -`A`a`^`•`q`^`A`] ^`i`a`a`q` }
 &`e`A`e`^`•`A`i`q`~`^`i`a`e` a`e`^`A`i`A`o`A`i`a`d` [i`a` a`A` [, ^`i`E`
 OPS-R-0020_A

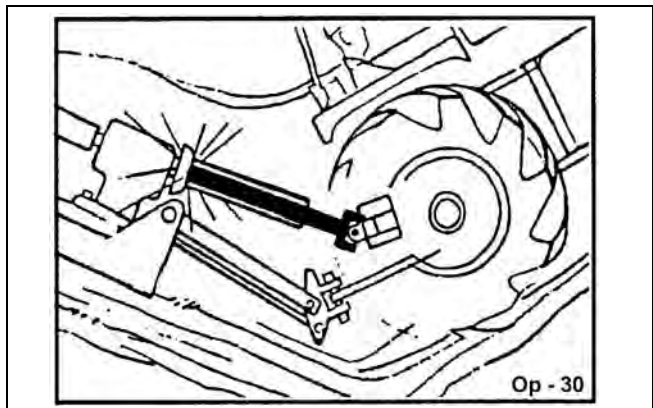

Op - 30

VY`@`A`U`V`O`E`Y`

U`] ^`i`a`a`q` } A`i`^`&`q` } A`E`E`F`

CD9F5HCB

CD9F5HCB

+06

Y @ } A& } -[] c^aA ~oAe } Aq & q ^A | Aa ~& @Za [A] c
 ae] | | ae @A [{ Aa } Aa * ^A } @& @A ^ | ^) aae } ae A |
 • d ae @A } Aa Aa ae ^A ae A && ' E

Y @ } A& [•• q * A ~ & @A | | ae E @A [] | ^ ^) oA @ ~ | a
 a^A ~ | | A [, ^ | ^ aA | Aa [, ^ | A &) c^A A | ae a A } a
 ae a^a A ae aac E OPS-R-0021_A

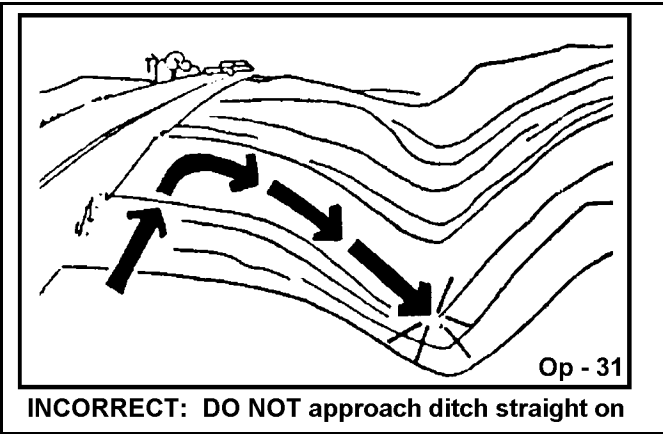

Q & q ^• Aa } aAa ~& @• A @ ~ | aA ^ Aa } | | ae @ aAa [] * Aa
 | a ^A } @& @A Aa } Aa * ^Aa A @ , } EAV @ A c] ^A ~
] ae A } a | A a ~ & ^ A @ A [•• ae aac A Aa ae ae ^ E @ A @
 * | ae a } oA A [A c ^] A @ a ~ & @A } Aa } | | ae @
 q & ^ ae ^ A @ A [•• ae aac A Aa ae ae | A | | E c ^ | E ^ | ^ & c
 ae Aa c | } ae Aa [•• q * A ae @A

Y @ } A [] ^ | ae a * A @ A | ae d | Aa } aA [, ^ | Aa [••
 • | | ^• Aa } aA } & q ^• E @ [~ * @Aa ~& @• Eae } aA c @ |
 ~ } ^ c ^) Aa | | ae Aa } aae } • E @ A A [] | | ae oA A ae ae
 • ~ ae } oA ^ & Aa A | | ~ } aA ^ ae ae & ^ A @ ae ^ Aa } ae c
 , ae @ @ A | | ~ } aA ae Aae • ^ A [aE A [& • Aa } aA c @ |
 a^a | aA Aa ^ A @ [, } A ~ oA [{ A } a^ | A @ A [, ^ |
 | ^• | q * Aa } A [•• ae | Aa b | ^ Aa } aA | A | |] ^ | c Aa ae ae ^ E
 O | | ~ } aA } ae oA } A | | a ~ & • Aa ^ c ^ | ^ A @ & A | ae
 [] A @ A [, ^ | Aa | a ^ Aa } aA | A @ A [, ^ | Aa | ae ^•
 | ^• | q * Aa } A [•• ae | Aa ae ae ^ Aa } aA | ^ { ae | ^ A ^ ae E
 OPS-R-0022_A

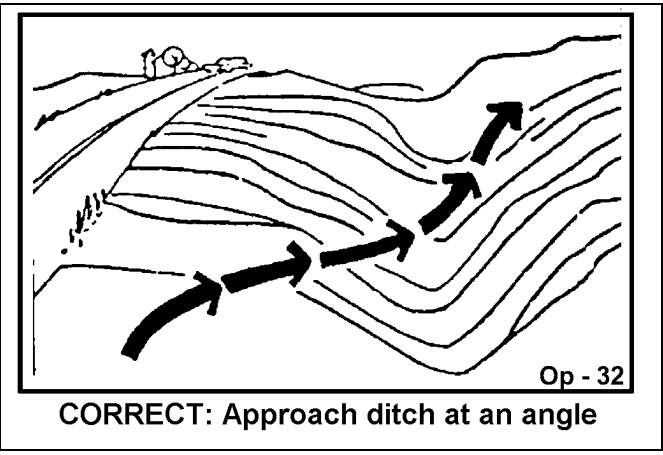

CD9F5HCB

"CD9F5HB; 'H<9'HF57HCF'5B8'AD@A9BH

H<9'CD9F5HCF'AI GH'7CAD@H9 @MI B89FGH5B8'<CK'HC'CD9F5H9'H<9'HF57HCF'5B8
 AD@A9BH'5B8'5 @7CBHFC@G'69: CF9'5HH9ADHB; 'HC'CD9F5H9"Á@Á] ^iæ |Á ~•OÁæáá } á
 ~} á!•æ } áÁ@Áæc Á } áÁ] ^iæ } Á^&ç } •Á Á@Á] |{ ^ } ó } áÁæç |Á] ^iæ | q Á } } æ ÉÁV@• ^
 { } } æ Á ~•OÁÁæáá } áÁç |æ } áÁ Á } ^ Á] ^iæ |Á @ Á } } [OÁæÉÁ^çÁ Á] , Á [{ ^ [] ^ Á Á] ^iæ Á@
 á] |{ ^ } ó } áÁæç |Á æç } OÁ [] |{ Á] ^iæ } *Á •ç } &ç } •É

O~ | ^ Á æç } * Á } ^ Á] ^iæ } É@ Á] ^iæ |Á ~•OÁÁ } { ^ Áæ } ááá } æ@Á@ÁæÁ Á Á] [| ^ áÁ } áÁ } ^
 [à } æÁ • Á } áÁææ } áÁ } } æ } áÁ } æç Á Á } • | ^ Áæc Á Á@ Á] ^iæ | ÉÁ • } áÁ } ÉÁ } áÁ } } á { ^ } ÉÁ] ^ &æ
 æ } ç } Á @ ~ | áÁ Á æÁ Á | ^ á } Á á à | á É [~ * @Á | æ ÉÁ ^ Á] Á [] ^ • ÉÁ } áÁæ • | • à } áÁ } áÁ } } æ } Á @ ÁæÁæ
 OPS-U- 0015



O | Á [ç [, Á æç [Á æç } ^ Á @ Áæ ^ ÁæÁæç } ç } æç ÁæÁæç | • Á æç Á } á , •
 & [• á ÉÁ



T [, Á] | ^ Á } áá } • Á @ | ^ Á [~ ÁæÁÁæç } áá } Á Áæ } á @ Á | Á æç ~ } æ Áæçæç
 | á } ç } ÉÁ^çÁ | , Á Áæ } • Á | Á } * * } áá } • Á @ | ^ Á [~ Áæ } [ç } Áæ | Á ^ ÁæÁæç
 HÉÁÁ^çÁ ÉÁ DÁ Á] } ó } áÁ Á@ Áæ • Á Á@ Áæç | Á } áÁ [, ^ ÉÁæ } áÁ ^ ÁæÁ [~ Áæ }
 & ^ æ | Á ^ Áæ } áÁ } ç } Áæ • | • à } ÉÁ ^ Á] Á [] ^ • ÉÁæç • ÉÁ [] É } ÉÁ ç | @ æÁ } à • ç } &ç } • É
] [, ^ Á } • ÉÁ á à | á } áÁ | ^ á } Á á } & ÉÁ [~ ÁæÁ } æ | Á Á } Áæ | Á ^ Á @ • Á Á] ^ Á Á } •
 áá } ç } ^ Á [, } * ÉÁ



Ç [æÁ [, } * Á ÁçÁ • ^ Áá ^ &ç } Á @ } Á [• • æ | ÉÁ @ & Á Á æ Á ^ | ^ Á @ | ^ Á Á []
] • [] • Á @ } áÁ @ Á [, ^ Á } áÁ • ^ Á ç ^ ^ ÁæÁ } @ } Á [, } * Á ÁçÁ • ^ ÉÁ [, Á] | ^ Áæ
 • [, Á | [~ } áÁ] ^ áÁ @ | ^ Á [~ Áæ } Áæ | Á] ^iæ Á } áÁ } d [| Á @ Áæç | Á } áÁ [, ^ É
 çÁ | Á [, Á } ÁæÁæç [~ ÁæÁ [çÁ] ^ &ç } áÁ } [ç } áÁ á à | á } Á | Á | ^ á } Á æ | æÉ
 ç | ÉÁ D

CD9F5HCB

CD9F5HCB

CD9F5HCB

!%: cfYI[b'8 YvfIq< UnUfXg

Ó-[-I^Á [, q * Éq •] ^&ó@ Áe^æÁ Á æ^Á~I^
 @-I^Áe^Á [Á I^á } Á àb&ó@e^Á [, ÁI^Á|æá•
 &I^ ÁÁ@Á I^Á &I^ { ^Á } ç * I^á Á @ÉU^ { [Ç^Áe
 [-I^á } Á àb&ó@ Áe áÁe^áI^ ÉQÁ àb&ó@ Áe^Á [Áe^Á
 I^ { [Ç^Áe æ^Á@ ÁI^æI^ Áe áÁe^Á~I^Á Á I^Ç^ } c
 @Á [, ÁI^Á|æá• ÁI^ { ÁI^ } çæç * Á@ { É

QÁ [~ Á@Áe [|æÁ àb&óÁ I^Á I^á } Áe^áI^ ÉQ [Á@
 { [, ÁI^Áe áÁeæç I^Áe } &ÉV æáÁ I^Áe [, ÁI^
 I^ çæç * Á [ç] ÁI^ Á ç] É@ } Áe^Á@Á [, ÁI^Áe á
 { [Ç^Á@Áeæç I^Áe áÁe] I^ ^ } ç^ Á@Á àb&ó@
 Q•] ^&ó@ Áe^æÁe áÁe^ { [Ç^Áe I^Á æ^Á@ÁI^ &æç }
 [Á@Áe^áI^ ÉQ•] ^&ó@ ÁI^ } áæç } Á Á@Á [, ÁI^
 çæç áÁe æ^Áe^ Á^á^áÁ^ æáÁ { ^áæe^ ÉÁI^ æ^
 • I^Á@Áe^ Áe^Á [Áeæ æ^áÁe áÁ@Áe^áI^ Áe
 àæç &áÁe^I^Áe^ { q * Á [ÁI^æç } É



FYa cj Y': cfYI[b'A Uhf]U

QÉ, æ•Á æáÁ~I^Áe^ÁI^Áe^ I^Áe^ Áe^ Áe^ á
 [] I^Á I^æe^Á@Áeæç I^Áe áÁ [, ÁI^Á æ@Á ÁUÚÚ
 q Á@Áe^áÁ [•æç] ÉQÁ@Áeæç I^Á I^Á [, ÁI^Áe Áe
 d^Ác { } ÉÁ & ÉÁ I^Á { } Ée^ áá^ } Á [Ç^Á^ } c
 &I^ ÁÁ@ [, Á [~ Á Á@Áe^æÁe áÁ } áÁ@
 dæç I^Áe áÁI^Á [, ÁI^ÉV@Áe^æÁe^Á I^Á I^Áe^c
 I^I^ ç&ç } ÁI^ { Áeç q * Á Á@Áeæç I^Áe áÁ@ ÁUÚÚ
 I^I^ çæe^Á I^I^ ç&ç } ÁI^ { Áe^ q * Áe^ • @áÁe^ I^ q * Áe
 dæç I^Á I^É Ç^ÁE OPS-R-0023_A



F UJgY Ack Yf'cj Yf'gc`]X'cV^Wg

"&6 nqIUbXYfg#DUggYfgVniDfYWI hcbg

QÁe^Á • çæ^ÁÁI^ { ^•Á æ@ Áe^Áe^Á@Áeæç I^Á @Á@Á [, ÁI^Á Áe^Á * Á I^æe^áÉQ [Á@Áeæç I^Áe á
 { [, ÁI^Áe^Á } &ÉQÁ [ÁI^ çæç@Á [, ÁI^Áe çæç ÁI^ çæç ÁI^ • çæç áÁe^Á ÁI^Á æ@Á Áe^Áe^Á [Áe^Á çæç &É OPS-
 R-0024_A

WARNING

Qçd^ { ^Áe^Áe^ @~I^Áe^Áe^ } Á @ } Á I^æç * Á^æç [•Á àb&ó•Á^&
 æ ÁI^æç I^Á & ÉÁ áÁe^Áe^ áÁ @Áe^áI^ ÉQ•] ^&ó@ Áe^æÁe^I^ I^
 { [, q * ÉQÁ I^á } Á àb&ó•Á @~I^Áe^Áe^ { [Ç^ÁÁI^ { Á@Áe^Áe^ Á I^Ç^ } c
 { çæç Áe^æç æ^Áe^ áÁI^Áe^ [áá Áe^ b I^ Á I^Ç^ } Áe^æç ÉQÉ~ Á àb&ó•Á@
 &ç } [ç^ÁÁ~ • çæç ÁI^æç I^Á æ^ÁÁe^ áÁe^Áe^ I^ Áe^ çæç áÁe^ Á@
 [] ÁI^æç I^ÉUQ [Á [, q * Áe^ { ^áæe^ I^Áe^æÁe^ Á d^Áe^Áe^ I^á } Á àb&ó@
 Ú] æáÁe^æç æ^Áe^ áÁe^ Áe^Áe^ ÁI^ d I^Á I^Áe^æÁe^ Áe^áI^ Áe^æç &á
 à-[-I^Áe^ { q * Á [, q * ÉÁ } OT ÉI D



VY @ ÁUUVÖEY

U] I^æç } ÁU^ç } ÁÉ

CD9F5HCB

WARNING

T æ ~ A ç æ ä ä A ä b & o E ~ & @ A ä a E æ æ E A [] ^ E A ; A & @ æ • E æ æ A & { ^ A } æ * | ä A A @ [] ^ | æ æ * Ä æ o Ä - Ä @ Ä [, ^ | Ä @ æ E A / @ • ^ A { • A | ä A @ } Ä , ä * Ä ~ o æ ^ Ä @ Ä ~ • ä * A æ * | ^ æ ; A ^ | [& ä ä • Ä @ ä Ä @ A | æ æ • E Ä ~ & @ ä ä æ æ } A Ä ç d ^ { ^ | Ä æ æ ä [~ A ä ä | | ä A ^ ~ | ç ä | ä ~ • A b | ^ Ä | Ä ç ^ } A ^ æ @ E A •] ^ & Ä @ Ä ~ æ * A æ æ Ä | Ä ~ & @ ä b & o Ä ^ - | ^ Ä [, ä * E Ü { [ç ^ A } ^ Ä ä Ä ä b & Ä [{ Ä @ Ä ä E Ä ^ ç ^ | A | | , Ä @ Ä ~ æ * A | æ æ • Ä | A [} æ ä ~ & @ { • E Ü Ö T E D

DANGER

Ü | æ ^ Ä [, ^ | A æ ^ A æ æ | A } ä | A æ ç ^ | ^ A & | ä ä } • Ä - Ä @ [, ä * [ä b & Ä | Ä | ^ æ ä ä æ & • Ä ç E A ^ ç | Ä [| ^ D æ ä ä æ • ä * Ä | ä ~ • A b | ^ | A ^ æ @ E A | | | , Ä æ ç Ä ^ • • æ ^ • A æ ~ | E



GHCDACK-B; ' = 'D5GG9FG6M5F9'K#k-B" \$\$: YHil B@GG.

E [] o æ ä Ä ^ æ Ä ^ - ^ & | • E Ö @ æ Ä ~ æ ä • E | Ä ç ä ä • A æ ^ A • æ | ^ ä ä ä ä Ä [[ä E [| | æ | A & | } ä ä } L

E [, ^ | A æ ^ A ~ } ä * A & | ^ A | ä ä ä ä | A | Ä @ Ä | [~ } ä Ä ä ~ o Ä ç [• ^ ä Ä | æ æ • L

E Ü æ • ^ | ä ^ æ ^ Ä ~ o æ ^ Ä @ Ä ç ä ç * Ä @ [, } E ä b & Ä [] ^ | Ä

E | A æ æ Ä @ æ ^ A ^ } Ä ç | [~ * @ A •] ^ & ç ä ä ä ä ä | A | ^ ä } Ä æ | ä ä ~ & @ Ä | & | E æ • E * | æ • E ä ä ^ } ^ | ä ä ä ä | ä Ä @ ä ^ } A { [ç ä E

NOTE: Where there are grass and weeds high enough to hide debris that could be struck by the blades, the area should be: inspected and large debris removed, mowed at an intermediate height, inspected, closely with any remaining debris being removed, and mowed again at desired final height. (This will also reduce power required to mow, reduce wear and tear on the Mower drivetrain, spread cut material better, reduce streaking, and make the final cut more uniform). Ä Ü T E F O

WARNING

Ö | Ä [o ^ Ä @ Ä | æ æ • A ~ | } Ä @ } Ä @ Ä [, ^ | Ä ^ & | A Ä æ ä ä Ä | A } ^ | ^ æ [] E ä & | ä ä * A | ^ æ æ & Ä | Ä | Ä | } ä * E Ä Ü æ ä * Ä @ Ä [, ^ | A ^ & | ^ ç [• ^ • Ä @ Ä ~ ç * Ä | æ æ • Ä @ Ä | ^ } ç æ | Ä | ä ~ • Ä @ æ æ ä ç ä ä | ä ~ | ä ä æ • ^ Ä | ä ~ • A b | ^ Ä | Ä ç ^ } A ^ æ @ A { Ä ä b & Ä @ [, } Ä [{ @ Ä | æ æ • E Ä Ü T E D



WARNING

O | Ä [o ^ o ^ o ä ä • Ä | A ^ ç } ä ^ | Ä [, ^ | A ^ & | E A | æ æ ^ A O [] æ & @ æ A ^ ~ | ç ä Ä | ä ~ • A b | ^ Ä | Ä ç ^ } A ^ æ @ E A ç ä ä Ä } ç ä | Ä [ç] Ä @ Ä ç [] ^ ä ç ä Ä @ Ä & | A æ ^ A ^ & | ^ | A | [& | ä Ä] E Ä Ü T E D



VY O Ä Ü V O E Y U | ^ | æ æ } Ä ^ & ç } Ä E

CD9F5HCB

CD9F5HCB

CD9F5HCB

áÈÒ`|á à!Áæ^•Á||, |ÁÈ@••Á|{ &|á à!Áæ &|!^&d^Á&| }^&•áÁ Áçç^Áæ} \È [|Á | |óÁ |á•Á } Áçç^ áæ \Á^óÁ [Á |, ÁÁ^ |æ^Áæ Á^~ áááÈ

^ÈÒç!Áæ•Á Á^áÁç^ &|•ç Á-Á çÁ [ÁÈ @ÁÁ æÁ } çÁ çÁ@æ Á } Á^{|!Á&@ &|á *Áç!Á æ^ÁÈÇ æ^Á |ææ•Á Á^áÁç^ } Áæ!Á } áÁ ÁÇ @Á } Áç!Á ~óÁ^Á^ |æ^ÁÈ



Þ^ç!Á |æ^Áç@Á|æç |Á |ÁÇ | |^ | ^ } óÁ } çÁ | ~ Áç^Á^ æÁæ á &| { | |ç!Á } á!•ç áÁ@Á ç } æÈ@Á|æç |Á |Áæ |ç ÁÁ ç } æÈ á ^æçÁ-Áç@Áæ^ç Á^••æ^Á^ } áÁ Áç@Á ç } çÁ!Á } Áç@Á|æç |Á ç á Ç | |^ | ^ } çÁ^æ } ÁÇ, Á | Á ç | Áç@Á|æç |Á } *á^Á^ áá^ | |Á Áæ |^ | |^ } &|È^ç!Áæ |, |Á ç | |á } &|á!Á } çæ^áá!• | | } |Á |Á |Áæ ç@Á|æç |Á |ÁÇ | |^ | ^ } óÁ ç@~óÁ^ | |çá á } ÈÁ ç^Á^!Áç@Á |Áæ | |ç Á^ |Áæá } áÁ } á!•ç | |Áç@Á ç } æÁ |á |Á |Á |Áæ | |ÈÁçÈD



È, æ•Á çæ çæ Áç@Áæ^ç Á } •Á Á [| |á^ææ|Á&| } áá } ÈÇ@Áæ^ç Á } •Á^Á á•á *È ááæ æ^ááÈ |Á } |^ææ|ÁÈ áçæ } áÁ ç |Á^ |æ^ | ^ } óÁæ^ç Á } •Á { |áæ^ | ÈÁçÈD



ÓÓÚÚÓÓæá *Áç@Á|æç |Á^æç, æ•Á^ç@Á ç!á *Á|æ^Áæ áÈ |Á^ç ç@Á|æç |Á ç } { á•á } |Á ç!á *Á^æÈá^ } *æ^Áç@ÁÚÚÈÁ ç | Áç ^ } á^È^ | |ç^Á^Á^ Èá áÁ æÁ |Áç | |çá *Á ç@Á |Á ç | ÈÁ |æ^Áç@Á çæç |Á ç@Á^ç!Á ç |Áæ |, Áæ *Á |Á ç!á *Á^æÁ |Á^ç^ } óÁç@Á | | { |Á |á *È^ç!Áæ | | } óÁ |Áæç |Áç@Á | |çá *Á |Á ç@Á^Á } *á^ á^ } á *ÈÁ |Áæ^Áç@Á |Áæ |Áç | |ç |Á | { |Áç@Á |Á^æ } | ÈÁçÈD

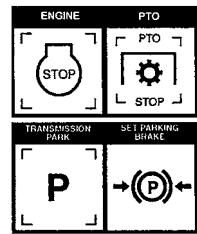

- "7 çbfc" @WU|çb`UbX: i bW|çbg

V@Áæ^Á |, |Áç@Á @Á&| } ç | |áá áç@ÁÈ [|Áç@Á^Á] [| |çç^Áæ áÁ&| [| |áá æ^áÁæ Áç, } Á^ | |, ÈÁç@ [| ç] ç!áç@Á [| |çç^Áæ |, •Á |Áç@Á |Áæ } Á-Áæ^Á çæ Á |, |Á |Áæ^Áæ@!Èç@Á } áÁ^ á } á } á, áç@Á^Á [| |çç^ÁÈ |Á |ç |Áæ^Áç@Á^ [| |çç^Á^ } |Á^æ^Á çæ Á |Áæ@!Áæ | | } çáÈ

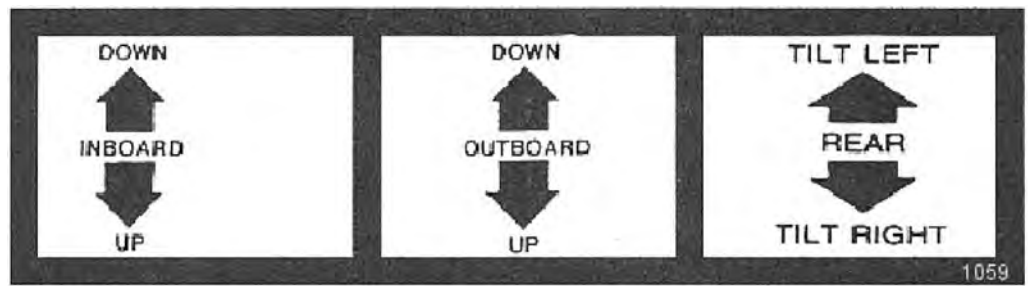

1059

V@Áæ^Á |, |Áç@Á @Á&| } ç | |áá áç@ÁÈ [|Áç@Á^Á] [| |çç^Áæ áÁ&| [| |áá æ^áÁæ Áç, } Á^ | |, ÈÁç@ [| ç] ç!áç@Á [| |çç^Áæ |, •Á |Áç@Á |Áæ } Á-Áæ^Á çæ Á |, |Á |Áæ^Áæ@!Èç@Á } áÁ^ á } á } á, áç@Á^Á [| |çç^ÁÈ |Á |ç |Áæ^Áç@Á^ [| |çç^Á^ } |Á^æ^Á çæ Á |Áæ@!Áæ | | } çáÈ

V@Áæ^Áæ áÁæ^Á |, |Á |Á^Á } •Á çæÁ } ç } æ |Á&| } ç | |áá áç@ÁÈ |çÁ^ | |ç@Á|æç |Á } ^&ç } | |Áæ | { áá çæ } Á-Áçç^Áæ áÁ^ | |ç@Á|æç |Áæ^Á çæ Á |Áæ@!Áæ | |ç@Á |Áæ^Á |Áæ^Á |, |Á ç |Á&| } ç | |áá^Áæ@Á | |ç@Á|æç

VY @ÁÚÚVçÈÿ U |Áæ } Á^&ç } ÁÈÇ

CD9F5HCB

CD9F5HCB

V@Á [, ^!Á á]Á]^!aeÁ [^!Á-ae} d' Á Á~ * @!Á] ááá } • Áé áÁ á@Á • Á [, ^!Á Á@Á } á • Áe Á Á ^ } o' @e } É Q@ Á [, ^!Á Á * á • Á Á Á áe Á Á d'] Á @ Á Áe d' | É & @ Á Á | Á á Á | áe] ^!Á Á Á @ Á } á | ^!Á | Á e áe áe ^!Á Á } á • É Y @ } Á] | áe á * Á } á • É Á | áe Á Á } á • Á á @ Á ^ , Á } á • Á Á } • ^!Á] [] ^!Á áe e } & Á Á [Á @ Á [, ^!Á á]Á [c çáe Á Á Á ^!Á Á áe } Á] Á Á ~ | e Á } á • Á á @ Á } ^ ~ e } Á e áe Á Á • Á á @ Á] [, Á @ Á • d' & e } • Á Á @ A UjbiVbUwW'GYW'jcb& [• ^! Á @ } Á] | áe á * Á } á • Á | áe Á • É

WARNING

Q@ • e á a ^! • Áe } | [e á @ Á e á Á e Á Á @ Á } @ Á [, ^!Á Á Á] ^!ae } É Á } Á [, ^!Á , áe @ Á] [, ^!Á { ^!Áe Á Á e Á Á @ e } , } É Á ^!Á Á e Á Á @ Á e d' | Á | Á Á [, Á • e á a ^! • Á Á } | [e á @ Á } , áe Á \$ \$ZYH Á @ Á } á } e Á Á [e } Á d'] • Á Á {] | e Á É

Y @ } Á } & ~ } e á á * Áe Á Á Á ^!Á Á } ááá } Á } @ Á e á • Á • Á @ Á e d' | Á Á e á | Á e á } * á Á [, ^!Á e á e d' | É | áe Á @ Á [, ^!Á] [Á @ Á e d' | Á Á e d' | Á Á e á a Á } ^!Á @ Á [, ^!Á e áe Á } á a Á Á | Á | Á e áe áe ^!Á Á ^!Á } áe á * Á [, ^!Á e áe } É

Q@ Á | áe Á • Áe Á | Á d' | É Á e Á } * á Á @ Á [, ^!Á } a Á e á Á @ Á e á Á | e } Á | Á e á Á @ Á e d' | Á Á e Á [| [e } Á e e , á | Á e á Á @ Á e e Á @ e Á e } [e } @ e Á @ Á [, ^!Á } É Á e á Á @ Á e e Á @ e Á e } | Á } Á Á @ Á e d' | Á } a Á Á e Á e } e } a * Á | áe Á Á Á [e } Á d'] • Á Á {] | e Á É Á e á Á @ Á e d' | Á } a Á | áe Á @ Á e } e } Á @ e Á } e } e Á É

5ZYH YZfghXUmicZcdYfUjcbZU''Vc'Iy'gl ci 'X'VY'W YW'YX'Ub'X'j [\ H'Y'YX'gYW'f'Y'ntV @ Á @ ~ | a Á Á Á] ^!Á e á e } Á Á } • ^!Á @ Á | e Á Á [e Á] { e Á } { ^!Á [• Á } a Á e e Á e áe áe Á Á @ Á e d' | Á | Á [, ^!Á | Á e Á | Á Á @ [] ^!ae } É

Y @ } Á [~ Á Á Á Á @ Á } a Á - Á e á e e Á | e } @ Á Á e Á Á @ { [, ^!Á } e Á + d' Á e } | ^!Á } } á * É Á ^!Á Á e Á Á @ { [, ^!Á } e Á | Á } @ Á @ Á | áe Á • Áe Á e } } á * É Á @ { [, ^!Á } • e Á Á e Á e á @ e Á @ Á Á G Á | { Á | } } a | ^!Á | É } e Á | Á e Á [, ^!Á | e á } Á Á Á { ^!Á Áe } & {] | e Á d' | Á e } | ^!Á] [& ^!Á á * Á | Á e Á Á @ { [, ^!Á } O X O U Á e Á Á @ Á [, ^!Á } @ Á @ Á | áe Á • e Á e } } á * É

OPS-R-0027_A



WARNING

Ö Á [o' Á @ Á | áe Á Á e } } Á } @ } Á @ Á [, ^!Á Á e Á Á e Á Á e } ^!Á e } É e } a á * Á | áe e } e Á | Á e } } á * É Á e á e } Á @ Á [, ^!Á e Á e Á e } e } e Á Á Á e } a Á e } a Á Á e } • Á e Á | e } • Á e Á | Á Á e } Á e e } | { Á e Á e Á @ [, } Á | { e Á | áe Á • É



CD9F5HCB



⚠ **DANGER** ⚠
 P^c^i^A^c^e^ a^A^i^A^e^|, A^e^| c^@^i^A^i^o^| } A^i^ A^c^e^ a^A^c^ ^ ^ A^e^ } a^ * A^i^e^d^ i^A^e^ a^A^o^ A^ |, ^i^ , @ } A^i^e^ & } } ^ & c^ * A^o^ A^ | | ^ (^) o^i^ { A^o^ A^i^e^d^ i^A^e^ | a^ A^o^e^



⚠ **DANGER** ⚠
 O^i^, e^ * A^ @ o^o^ A^i^e^d^ | A^i^ { | | ^o^i^ A^i^ |, } E^i^ | e^e^ A^o^ A^i^ e^ * { a^ * a^ } A^i^ A^e^ E^i^ e^ a^ A^o^o^ | e^ | a^ * A^i^ e^ A^i^ e^ | ^ A^ [^ A^ | A^e^ ^ | } ^ A^ | ^ A^e^ ^ | } o^ A^i^ A^i^ } } ^ & o^ A^i^ e^ & } } ^ & o^ A^o^ | | ^ (^) c^ e^ a^ A^i^ e^d^ | A^o^e^ * E^i^ H^U^V^E^I^ D

CD9F5HCB

ACK 9F`GHCF5: 9

O^i^ A^i^e^ { { ^ } a^ a^ A^o^o^ A^ |, ^i^ A^i^ e^d^ i^ a^ A^ a^o^o^ A^ |, ^i^ A^i^ | | A^i^ |, ^i^ a^ A^i^ A^i^ | } a^ A^c^ | E^i^ A^o^ A^ |, ^i^ A^i^ • d^ | ^ a^ A^ A^o^ A^e^ a^ A^ | • a^ } E^i^ | ^ & o^ A^i^ c^ | A^e^ a^ e^ a^ | e^e^ A^i^ | & • A^ } a^ i^ A^o^ A^ |, ^i^ A^i^ A^i^ c^ | o^o^ A^ |, ^i^ A^i^ | { e^i^ a^ * A^o^o^ U^o^o^ A^i^ e^ & } } ^ & c^ * A^o^ A^ |, ^i^ A^i^ | { A^o^ A^i^ e^d^ | E

U^i^ | | ^i^ A^i^ | ^i^ e^ a^ * A^e^ a^ A^d^ | a^ * A^o^ A^ |, ^i^ A^e^o^ A^ | a^ A^ A^o^ A^ a^e^ | } A^i^ A^i^ e^e^ A^i^ A^i^ e^ e^ a^ a^ * A^i^ A^e^ | ^ e^ e^ & a^ e^ a^ A^i^ A^o^ | | A^ } • ^i^ A^ a^ e^ A^i^ A^ | ^i^ a^ e^ | A^i^ c^ e^ E^i^ A^o^ A^ | | |, a^ * A^e^ A^i^ * * ^ o^ e^ a^ A^d^ | e^ A^i^ | | & a^ ^i^ A^o^ K

- ~ V@ | | ^ * @ A^i^ e^ A^e^ | A^i^ a^i^ a^ A^i^ A^o^ A^ |, ^i^ A^i^ | | ^c^ | o^ a^ e^ e^ A^i^ | | { A^i^ | | e^ a^ * A^i^ e^ * A^ e^ a^ • e^ a^ a^ * A^i^ e^ | E
- ~ S^i^ a^i^ e^e^ A^e^ | A^ |, ^i^ A^i^ e^ a^ A^i^ | | a^ c^ A^e^ a^ A^i^ | | a^ | | c^ | • A^e^ A^i^ e^ a^ A^o^ A^ | e^ e^ | e^ & A^i^ e^d^ | E
- ~ V^a^ @ } A^i^ A^i^ | | o^ A^e^ a^ A^ a^ * A^i^ A^o^ A^i^ e^ { { ^ } a^ a^ d^ | | ^ ^ E
- ~ O^o^ & A^o^ A^ |, ^i^ A^i^ | | A^i^ | | } A^e^ a^ A^ a^ e^ e^ a^ a^ | e^o^ E^i^ A^i^ | | | { A^i^ | } e^e^ A^e^ a^ A^ { e^ A^i^ | } e^e^ a^ { ^ a^ e^ | ^ A^ | A^o^o^ A^ | { |, ^i^ A^i^ | | A^i^ e^ a^ | | A^o^ A^i^ e^d^ | } E
- ~ U^d^ | ^ A^o^ A^ |, ^i^ A^i^ A^i^ e^ E^i^ | ^ A^i^ | e^ A^i^ a^o^o^ { |, ^i^ A^i^ | ^i^ a^ * A^i^ e^d^ * A^i^ e^ | | ^i^ A^i^ | | A^i^ | | & • A^i^ | e^e^ A^i^ | } a^ A^c^ | E
- ~ W^ ^ A^i^ | e^ A^i^ | ^ & E^ | A^i^ e^ | | A^i^ | ^ A^i^ e^e^ e^ d^ | ^c^ | o^ a^ • o^e^ a^ A^i^ e^ e^ a^ A^o^ A^ | ^ e^ e^ & A^i^ o^o^ A^ |, ^i^ E^i^



AOPS-R-214



⚠ **DANGER** ⚠
 P^c^i^A^e^ |, & @ a^i^ A^i^ A^i^ o^ | A^i^ o^ | } • A^i^ A^e^ A^i^ A^o^ A^i^ e^d^ | A^i^ A^o^ | | ^ (^) E
 O^e^ | a^ * A^i^ e^ a^ A^i^ e^ | o^e^ A^i^ e^ | • A^i^ b^i^ | ^ A^i^ e^e^d^ | U^o^e^o^



CD9F5HCB

CD9F5HCB

Y @ } A] ^ | a a c j * A } A } ^ a | a A [a a • E A c a ^
 & [] • a a ^ | a a j } A f : A c o | A [a a A • ^ | • E U ~ | | A f A c A a a ^
 [- A c A [a a A & a a a } a f ^ A f A e | | , A e | A f | | | , a * A i a e - a
 d A a e • E O [A [o ^ c & ^ a a c A * a f A] ^ a a A a a ^ a a
 ^ [^ | A f ~ } d ^ A f | A e | a e | c | a f A i a a d | • E O f , a e • A a e
 a f ^ i o j @ } A i a j •] [| c j * A c A i a a d | A a a A } | ^ { ^ } c
 [] A ^ a | a A [a a • E A ^ a a e e c j } A a a A a ^ & A] ^ a a A
 [c o | A ^ c a ^ A i A a a ^ d a a } A a a A a c A a a e O P S -
 U - 0022



Op-596

⚠ DANGER

Do not operate the machine on a slope. The machine is designed to operate on a level surface. Operating on a slope can cause the machine to tip over, resulting in serious injury or death.



⚠ WARNING

The machine is equipped with a safety interlock system. This system prevents the machine from operating unless the operator is seated and the safety interlock is engaged. If the safety interlock is not engaged, the machine will not start. Always use the safety interlock system to prevent accidental starting.

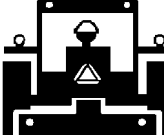

Use the machine on a level surface. The machine is designed to operate on a level surface. Operating on a slope can cause the machine to tip over, resulting in serious injury or death. Always use the machine on a level surface.



Op-25

VY O ÄUUVÖEY

U] ^ | a a c j } A ^ & c j } A e e

CD9F5HCB

Op - 46

Op - 46
 1. 2. 3. 4. 5. 6. 7. 8. 9. 10. 11. 12. 13. 14. 15. 16. 17. 18. 19. 20. 21. 22. 23. 24. 25. 26. 27. 28. 29. 30. 31. 32. 33. 34. 35. 36. 37. 38. 39. 40. 41. 42. 43. 44. 45. 46. 47. 48. 49. 50. 51. 52. 53. 54. 55. 56. 57. 58. 59. 60. 61. 62. 63. 64. 65. 66. 67. 68. 69. 70. 71. 72. 73. 74. 75. 76. 77. 78. 79. 80. 81. 82. 83. 84. 85. 86. 87. 88. 89. 90. 91. 92. 93. 94. 95. 96. 97. 98. 99. 100.



Op - 46

Op - 47
 1. 2. 3. 4. 5. 6. 7. 8. 9. 10. 11. 12. 13. 14. 15. 16. 17. 18. 19. 20. 21. 22. 23. 24. 25. 26. 27. 28. 29. 30. 31. 32. 33. 34. 35. 36. 37. 38. 39. 40. 41. 42. 43. 44. 45. 46. 47. 48. 49. 50. 51. 52. 53. 54. 55. 56. 57. 58. 59. 60. 61. 62. 63. 64. 65. 66. 67. 68. 69. 70. 71. 72. 73. 74. 75. 76. 77. 78. 79. 80. 81. 82. 83. 84. 85. 86. 87. 88. 89. 90. 91. 92. 93. 94. 95. 96. 97. 98. 99. 100.



Op - 47

Op - 48
 1. 2. 3. 4. 5. 6. 7. 8. 9. 10. 11. 12. 13. 14. 15. 16. 17. 18. 19. 20. 21. 22. 23. 24. 25. 26. 27. 28. 29. 30. 31. 32. 33. 34. 35. 36. 37. 38. 39. 40. 41. 42. 43. 44. 45. 46. 47. 48. 49. 50. 51. 52. 53. 54. 55. 56. 57. 58. 59. 60. 61. 62. 63. 64. 65. 66. 67. 68. 69. 70. 71. 72. 73. 74. 75. 76. 77. 78. 79. 80. 81. 82. 83. 84. 85. 86. 87. 88. 89. 90. 91. 92. 93. 94. 95. 96. 97. 98. 99. 100.



Op - 48

MAINTENANCE SECTION

Maintenance Section 4-1

MAINTENANCE

GENERAL INSTRUCTIONS

Tiger Mowers are designed for high performance and rugged durability, yet with simplified maintenance. The purpose of this section of the manual is to help the operator in the regular servicing of the mower. Regular maintenance at the intervals mentioned will result in the maximum efficiency and long life of the Tiger Mower.

When you purchase a Tiger Mower you also acquire another valuable asset, Tiger's parts organization. Our rapid and efficient service has guaranteed the customer satisfaction for many years. Tiger parts keep up with the demands for efficiency, safety and endurance expected of the Tiger Mower.

MAINTENANCE PRECAUTIONS

- Be sure end of grease gun and zerks are clean before using. Debris injected into bearings, etc. with grease will cause immediate damage.
- DO NOT use a power grease gun to lubricate bearings. These require very small and exact amounts of lubrication. Refer to the detailed maintenance section for specific lubrication instructions. DO NOT over-grease bearings.
- Lexan windows should be washed with mild soap or detergent and lukewarm water, using a soft clean sponge or soft cloth. DO NOT use abrasive or alkaline cleaners or metal scrapers on lexan windows!
- Be alert to maintenance indicators such as the in-tank filter pressure gauge, hydraulic reservoir sight gauge, etc. Take the required action to correct any problems immediately.
- Release of energy from pressurized systems may cause inadvertent actuation of cylinders, or sudden release of compressed springs. Before disconnecting any hoses relieve pressure by shutting tractor off, setting cutter on ground and actuating lift valve handles.

WARNING

DO NOT use hands to check for suspected leaks in hydraulic hoses! Hydraulic fluid escaping under pressure can have sufficient force to penetrate skin and cause serious injury. If fluid is injected into skin, it must be surgically removed within a few hours or gangrene may result. Use a small piece of wood or cardboard, not hands, to search for pin hose leaks. Be sure all connections are tight and hoses and lines are not damaged before applying pressure.

BREAK IN PERIOD

In addition to following the break-in instructions for your particular tractor, the in-tank hydraulic fluid filter should be replaced after the first 50 hours of service. Thereafter the filter should be replaced every 500 hours, or yearly, whichever comes first.

Re-torque wheel lugs after first five hours of operation and periodically thereafter. See torque specifications listed in the tractor's service manual for your particular model. **Wheel lugs must always be re-torqued whenever a wheel is removed and reinstalled.**

DANGER

Never work under the Implement, the framework, or any lifted component unless the Implement is securely supported or blocked up to prevent sudden or inadvertent falling which could cause serious injury or even death. (SG-14)



MAINTENANCE



Do not modify or alter this Implement. Do not permit anyone to modify or alter this Implement, any of its components or any Implement function. (SG-8)



Relieve hydraulic pressure prior to doing any maintenance or repair work on the Implement. Place the Mower Head on the ground or securely supported on blocks or stands, disengage the PTO, and turn off the engine. Push and pull the control Levers or Joystick several times to relieve pressure prior to starting any maintenance or repair work. (SBM-6)



Always disconnect the wire leads from the mower pump solenoid before performing service on the Tractor or Mower. Use caution when working on the Tractor or Mower. Tractor engine must be stopped before working on Mower or Tractor. The Mower Blades could inadvertently be turned on without warning and cause immediate dismemberment, injury or death. (SBM-12a)

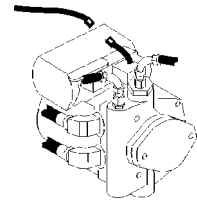

MAINTENANCE

REGULAR MAINTENANCE

The intervals at which regular servicing should be done are based on hours of operation. Use the tractors hour meter to determine when regular servicing is required.

Daily or Every 8 Hours

| ITEM | SERVICE | COMMENTS |
|--|-----------------------|--|
| Drive Shaft Yoke, U-Joint & Stub Shaft | Grease | Grease as instructed in detailed Maintenance Section |
| Pump Drive Shaft | Check and Lube | Insure drive shaft end play |
| Crankshaft Adapter | Check rubber grommets | Replace grommets if damaged or missing |
| Pivot Points | Lubricate | Inject grease until it appears at end |
| Hydraulic Fittings | Check for leaks | Tighten when needed. Do Not use hands to che ck for leaks. See Maintenance Precautions |
| Spindle mounting bolts (spindle to deck) | Check | 3/4" x 2" torque to 331ft. lbs. |

TWIN ROTARY

Maintenance Section 4-3

MAINTENANCE

MAINTENANCE

| ITEM | SERVICE | COMMENTS |
|--|---------|---|
| Disk mounting bolts (disk to spindle) | Check | 5/8" X 1-3/4" bolt torque to 204 dry or 184 oiled ft. lbs. |
| Main Frame and Deck | Check | Retorque bolts to torque specifications in this section |
| Hydraulic Fluid Level | Check | Add if required per fluid recommendations |

WEEKLY OR EVERY 40 HOURS

| ITEM | SERVICE | COMMENTS |
|----------------|-----------|---|
| Rotary Spindle | Lubricate | Grease as instructed in detailed Maintenance Section |

WEEKLY OR EVERY 50 HOURS

| ITEM | SERVICE | COMMENTS |
|---|---------|--|
| In Tank Hydraulic Fluid Filter (10 micron filter) | Change | Change after first 50 hours only then every 500 hours or yearly |
| In-Line High Pressure Filter (10 micron filter) | Change | Change after first 50 hours only then every 500 hours or yearly |

MAINTENANCE

MONTHLY OR EVERY 150 HOURS

| ITEM | SERVICE | COMMENTS |
|-------------------------|---------------------|--------------------------------------|
| Hydraulic Fluid Level | Check | Add as needed |
| Hydraulic Tank Breather | Clean/Check/Replace | Clean or replace Element as required |
| Rear Tire Type | Max P.S.I. | |
| 480/80R38 | 29 | |
| 18.4-34 | 26 | |
| 18.4-38 | 26 | |

YEARLY OR EVERY 500 HOURS

| ITEM | SERVICE | COMMENTS |
|---|---------|---|
| Spindle Grease | Change | |
| Motor to Spindle Spline Grease | Change | |
| Hydraulic Tank Fluid | Change | |
| In Tank Hydraulic Fluid Filter (10 micron filter) | Change | |
| In-Line HP Filter (10 micron filter) | Change | or Change when indicated by restriction indicator. |
| Hydraulic Tank Breather | Change | |

MAINTENANCE

MAINTENANCE

MAINTENANCE

TROUBLESHOOTING

| SYMPTOMS | CAUSE | REMEDY |
|-----------------------------|--|---|
| Vibration | Loose Bolts | Check all bolts and tighten to recommended torque specifications in this section |
| | Cutter assembly | a. Check for damaged blades, disc, unbalanced or cutter shaft. b. Replace if needed. c. Check for wire, rope, etc. entangled in the cutter assembly |
| Mower will not lift | Hydraulic Fluid Low Leaks in line Faulty relief valve | Check and refill Hyd Fluid Tighten or replace fittings and hoses Check pressure in line. Line pressure in Control Valve should be at least 2500 P.S.I. |
| | Kinked or blocked | Clean or replace lines |
| | Faulty cylinder | Inspect, repair or replace cylinder |
| Oil Temperature rises | Low oil level above 200°F Kinked/blocked hoses Worn pump/motor | Bring oil to proper level. Inspect / Repair / Replace Disable and Repair |
| Mower will not start or run | Blown fuse | Check fuse between mower switch and ignition / replace |
| | Ball valves closed Low oil level Line leak | Make sure valves are open Check Hyd. tank and fill Check all fittings and lines, re-tighten or replace |
| | Electronic solenoid faulty | a. Without the tractor running, turn the mower switch to on. A low audible click is not heard if the solenoid is engaging the solenoid spool. If click is not heard, leave switch in on position and with a screwdriver or other steel object, touch the small nut on the end of the solenoid. If the metallic object is not attracted to the nut, check the fuse and wiring for an open circuit. If the object is attracted but no "click" is heard, replace the solenoid. |

MAINTENANCE

- b. Remove the four bolts holding the small block to the main block. Lift and remove small block being careful not to damage O-rings/filter.
- c. Clean filter and re-install.
- d. Remove large nut on side of large valve block. Remove spring, and use needle nose vise grip to pull spool from block. Check block and spool for contaminants and scratches. Clean parts or replace if scratched.

Mower turns slowly or not at all

Contaminants restricting spool movement in valve body

Remove large nut on side of large valve block. Remove spring, and use needle nose vise grip to pull spool from block. Check block and spool for contaminants and scratches.

Clean parts or replace if scratched.

Suction lines obstructed

Check for kinks or obstruction in suction hose.

Low oil level

Check Hyd. tank level and fill.

Pump will not work

Excessive wear on internal parts

Disassemble and repair.

Motor will not work

Excessive wear on internal parts

Disassemble and repair

NOTE: *If flow meter is available, check pressure and flow volume for all suspected hydraulic problems.*

If the solution to your problem cannot be found in this section, call the Technical Service representative at the number shown on the front cover of this manual.

MAINTENANCE

MAINTENANCE

TORQUE SPECIFICATIONS

| Torque for Standard Fasteners | | | | | | | | | | | | | |
|-------------------------------|------------------|-------------------|------------------------|-----------------------|-------------------|------------------------|-----------------------|-------------------|------------------------|-----------------------|-------------------|------------------------|-----------------------|
| Nominal Dia. (in.) | threads per inch | Grade 2 | | | Grade 5 | | | Grade 8 | | | Grade 9 | | |
| | | Tightening Torque | | | Tightening Torque | | | Tightening Torque | | | Tightening Torque | | |
| | | Lubed K = 0.15 | Dry Plated K = 0.17 | Dry plain K = 0.20 | Lubed K = 0.15 | Dry Plated K = 0.17 | Dry plain K = 0.20 | Lubed K = 0.15 | Dry Plated K = 0.17 | Dry plain K = 0.20 | Lubed K = 0.15 | Dry Plated K = 0.17 | Dry plain K = 0.20 |
| Unified Coarse Thread Series | | | | | | | | | | | | | |
| 1/4 | 20 | 49 in-lbs | 59 in-lbs | 66 in-lbs | 76 in-lbs | 86 in-lbs | 101 in-lbs | 107 in-lbs | 122 in-lbs | 143 in-lbs | 126 in-lbs | 143 in-lbs | 168 in-lbs |
| 5/16 | 18 | 101 | 122 | 135 | 157 | 178 | 209 | 221 | 251 | 295 | 259 | 294 | 346 |
| 3/8 | 16 | 15 ft-lbs | 18 ft-lbs | 20 ft-lbs | 23 ft-lbs | 26 ft-lbs | 31 ft-lbs | 33 ft-lbs | 37 ft-lbs | 44 ft-lbs | 38 ft-lbs | 43 ft-lbs | 51 ft-lbs |
| 7/16 | 14 | 24 | 29 | 32 | 37 | 42 | 49 | 52 | 59 | 70 | 61 | 70 | 82 |
| 1/2 | 13 | 37 | 44 | 49 | 57 | 64 | 75 | 80 | 90 | 106 | 94 | 106 | 125 |
| 9/16 | 12 | 53 | 63 | 70 | 82 | 92 | 109 | 115 | 130 | 154 | 135 | 153 | 180 |
| 5/8 | 11 | 73 | 87 | 97 | 113 | 128 | 150 | 159 | 180 | 212 | 186 | 211 | 248 |
| 3/4 | 10 | 129 | 155 | 172 | 200 | 227 | 267 | 282 | 320 | 376 | 331 | 375 | 441 |
| 7/8 | 9 | 125 | 150 | 167 | 322 | 365 | 429 | 455 | 515 | 606 | 533 | 604 | 710 |
| 1 | 8 | 187 | 225 | 250 | 483 | 547 | 644 | 681 | 772 | 909 | 799 | 905 | 1065 |
| 1 1/8 | 7 | 266 | 319 | 354 | 596 | 675 | 794 | 836 | 966 | 1132 | 988 | 1132 | 1341 |
| 1 1/4 | 7 | 375 | 450 | 500 | 840 | 952 | 1121 | 1163 | 1345 | 1577 | 1377 | 1577 | 1870 |
| 1 1/2 | 6 | 652 | 783 | 869 | 1462 | 1657 | 1950 | 2017 | 2311 | 2711 | 2379 | 2711 | 3206 |
| Fine Thread Series | | | | | | | | | | | | | |
| 1/4 | 28 | 56 in-lbs | 68 in-lbs | 75 in-lbs | 87 in-lbs | 99 in-lbs | 116 in-lbs | 123 in-lbs | 139 in-lbs | 164 in-lbs | 144 in-lbs | 163 in-lbs | 192 in-lbs |
| 5/16 | 24 | 112 | 135 | 150 | 174 | 197 | 231 | 245 | 278 | 327 | 287 | 325 | 383 |
| 3/8 | 24 | 17 ft-lbs | 20 ft-lbs | 23 ft-lbs | 26 ft-lbs | 30 ft-lbs | 35 ft-lbs | 37 ft-lbs | 42 ft-lbs | 49 ft-lbs | 43 ft-lbs | 49 ft-lbs | 58 ft-lbs |
| 7/16 | 20 | 27 | 32 | 36 | 41 | 47 | 55 | 58 | 66 | 78 | 68 | 78 | 91 |
| 1/2 | 20 | 41 | 49 | 55 | 64 | 72 | 85 | 90 | 102 | 120 | 105 | 120 | 141 |
| 9/16 | 18 | 59 | 71 | 78 | 91 | 103 | 121 | 128 | 146 | 171 | 151 | 171 | 201 |
| 5/8 | 18 | 82 | 99 | 110 | 127 | 144 | 170 | 180 | 204 | 240 | 211 | 239 | 281 |
| 3/4 | 16 | 144 | 173 | 192 | 223 | 253 | 297 | 315 | 357 | 420 | 369 | 418 | 492 |
| 7/8 | 14 | 138 | 165 | 184 | 365 | 403 | 474 | 502 | 568 | 669 | 588 | 666 | 784 |
| 1 | 14 | 210 | 252 | 280 | 542 | 614 | 722 | 765 | 867 | 1020 | 896 | 1016 | 1195 |
| 1 1/8 | 12 | 298 | 357 | 397 | 668 | 757 | 890 | 1083 | 1227 | 1444 | 1269 | 1439 | 1693 |
| 1 1/4 | 12 | 415 | 498 | 553 | 930 | 1055 | 1241 | 1509 | 1710 | 2012 | 1768 | 2004 | 2358 |
| 1 1/2 | 12 | 734 | 880 | 978 | 1645 | 1865 | 2194 | 2668 | 3024 | 3557 | 3127 | 3544 | 4169 |

Torque values for 1/4 and 5/16-in series are in inch-pounds. All other torque values are in foot-pounds. K = 0.15 for "lubricated" conditions; D = Nominal Diameter
 Torque values calculated from formula T=KDF, where K = 0.17 for zinc plated and dry conditions; F = Clamp Load
 K = 0.20 for plain and dry conditions

| Torque-Tension Relationship for Metric Fasteners | | | | | | | | | | | | | |
|--|-------|-------------------|------------------------|-----------------------|-------------------|------------------------|-----------------------|-------------------|------------------------|-----------------------|-------------------|------------------------|-----------------------|
| Nominal Dia. (mm) | Pitch | Class 4.6 | | | Class 8.8 | | | Class 10.9 | | | Class 12.9 | | |
| | | Tightening Torque | | | Tightening Torque | | | Tightening Torque | | | Tightening Torque | | |
| | | Lubed K = 0.15 | Dry Plated K = 0.17 | Dry plain K = 0.20 | Lubed K = 0.15 | Dry Plated K = 0.17 | Dry plain K = 0.20 | Lubed K = 0.15 | Dry Plated K = 0.17 | Dry plain K = 0.20 | Lubed K = 0.15 | Dry Plated K = 0.17 | Dry plain K = 0.20 |
| 3 | 0.5 | 0.28 | 0.32 | 0.38 | 0.73 | 0.82 | 0.97 | 1.0 | 1.2 | 1.4 | 1.2 | 1.8 | |
| 3.5 | 0.6 | 0.44 | 0.50 | 0.59 | 1.1 | 1.3 | 1.5 | 1.6 | 1.9 | 2.2 | 1.9 | 2.5 | |
| 4 | 0.7 | 0.66 | 0.74 | 0.87 | 1.7 | 1.9 | 2.3 | 2.4 | 2.7 | 3.2 | 2.8 | 3.8 | |
| 5 | 0.8 | 1.3 | 1.5 | 1.8 | 3.4 | 3.9 | 4.5 | 4.8 | 5.5 | 6.5 | 5.7 | 7.6 | |
| 6 | 1 | 2.3 | 2.6 | 3.0 | 5.8 | 6.6 | 7.7 | 8.3 | 9.4 | 11 | 9.7 | 13 | |
| 6 | 1.25 | 2.1 | 2.3 | 2.7 | 5.3 | 6.0 | 7.0 | 7.6 | 8.6 | 10 | 8.6 | 12 | |
| 7 | 1 | 3.8 | 4.3 | 5.0 | 9.7 | 11 | 13 | 14 | 16 | 19 | 16 | 22 | |
| 8 | 1 | 5.8 | 6.6 | 7.8 | 15 | 17 | 20 | 22 | 24 | 29 | 25 | 34 | |
| 8 | 1.25 | 5.5 | 6.2 | 7.3 | 14 | 16 | 19 | 20 | 23 | 27 | 24 | 31 | |
| 10 | 1.25 | 11 | 13 | 15 | 29 | 33 | 39 | 42 | 48 | 56 | 49 | 66 | |
| 10 | 1.5 | 11 | 12 | 14 | 28 | 32 | 37 | 40 | 45 | 53 | 47 | 62 | |
| 12 | 1.25 | 21 | 23 | 28 | 53 | 60 | 71 | 76 | 86 | 101 | 89 | 119 | |
| 12 | 1.5 | 20 | 22 | 26 | 51 | 58 | 68 | 73 | 82 | 97 | 85 | 113 | |
| 12 | 1.75 | 19 | 21 | 25 | 49 | 55 | 65 | 70 | 79 | 93 | 81 | 108 | |
| 14 | 1.25 | 26 | 29 | 34 | 66 | 75 | 89 | 95 | 108 | 127 | 111 | 148 | |
| 14 | 1.5 | 28 | 32 | 37 | 72 | 82 | 96 | 103 | 117 | 138 | 121 | 161 | |
| 14 | 2 | 30 | 34 | 40 | 78 | 88 | 104 | 111 | 126 | 148 | 130 | 173 | |
| 16 | 1.5 | 50 | 57 | 67 | 129 | 146 | 171 | 184 | 208 | 245 | 215 | 287 | |
| 16 | 2 | 47 | 53 | 62 | 121 | 137 | 161 | 173 | 196 | 230 | 202 | 269 | |
| 18 | 1.5 | 73 | 82 | 97 | 187 | 212 | 249 | 268 | 303 | 357 | 313 | 417 | |
| 18 | 2.5 | 65 | 73 | 86 | 167 | 189 | 222 | 239 | 270 | 318 | 279 | 372 | |
| 20 | 1.5 | 101 | 115 | 135 | 270 | 306 | 360 | 374 | 424 | 498 | 437 | 583 | |
| 20 | 2.5 | 91 | 104 | 122 | 238 | 267 | 314 | 337 | 382 | 449 | 394 | 525 | |

Clamp load calculated as 75% of the proof load for specified bolts. K = 0.15 for "lubricated" conditions; D = Nominal Diameter
 All torque values are listed in foot-pounds; K = 0.17 for zinc plated, dry conditions; F = Clamp Load
 Torque values calculated from formula T=KDF, where K = 0.20 for plain and dry conditions

MAINTENANCE

MAINTENANCE

LUBRICATION RECOMMENDATIONS

| DESCRIPTION | APPLICATION | GENERAL SPECIFICATION | RECOMMENDED MOBIL LUBRICANT |
|---|-----------------------------------|---|-----------------------------|
| Tractor Hydraulics | Reservoir | JD-20C MF M1135, M1141 FNHM2C134D (FNH201) | Mobilfluid® 424 |
| Mower Hydraulics | Reservoir | | |
| | Cold Temperatures 0°F Start-Up | ISO 46 Anti-Wear-Low Temp | Mobil DTE 15M |
| | Normal Temperatures 10°F Start-Up | JD-20C MF M1135, M1141 FNH M2C134D (FNH201) | Mobilfluid 424 |
| | Normal Temperatures 15°F Start-Up | ISO 46 Anti-Wear | Mobil DTE 25 |
| | High Operating Temp. Above 90°F | ISO 100 Anti-Wear | Mobil DTE 18M |
| Drive Shaft Coupler | Grease Gun | Lithium-Complex Extreme Pressure NLGI 2 - ISO 320 | Mobilgrease CM-S |
| Drive Shaft Yoke, U-joint & Stub Shaft | Grease Gun | Lithium-Complex Extreme Pressure NLGI 2 - ISO 320 | Mobilgrease CM-S |
| Deck Spindle (Rotary) | Grease Gun | Tiger Part Spindle Lubricant Part Number 06540000 | Mobilith SHC 220 |
| Motor Spline | | | Moly 52 |

MAINTENANCE

POLYCARBONATE CARE & MAINTENANCE

The proprietary UV and Abrasion Resistant surface coating on SHIELDS SUPERCOATED polycarbonate significantly improves performance. Periodic cleaning using proper procedures and compatible cleaners are recommended to prolong service life. Tiger Corp. polycarbonate is SUPERCOATED on both sides.

CLEANING THE SUPERCOAT HARD-COAT

1. Wash with a mild solution of soap or detergent and lukewarm water.
2. Using a soft cloth or sponge, gently wash the sheet to loosen dirt and grime and rinse well with clean water.
3. To prevent water spotting, thoroughly dry with chamois or cellulose sponge.
4. Avoid the use of abrasive cleaners, squeegees and/or other cleaning implements that may mar or gouge the coating.

CLEANING AGENTS WHICH HAVE BEEN FOUND TO BE COMPATIBLE UNDER LABORATORY CONDITIONS:

- Aqueous Solutions of Soaps and Detergents

| | | | |
|-----------|-------------|---------------|------------|
| Windex | Top Job | Joy | Mr. Clean |
| Fantastik | Formula 409 | Sumalight D12 | Brucodecid |

- Organic Solvents

| | | | |
|------------------|------------|-----------------|----------------------|
| Butyl Cellosolve | Kerosene | Hexel, F.O. 554 | Naphtha (VM&P Grade) |
| Neleco-Placer | Turco 5042 | | |

- Alcohols

| | |
|----------|-----------|
| Methanol | Isopropyl |
|----------|-----------|

All residual organic solvents should be removed with a secondary rinse.

GRAFFITI REMOVAL

Butyl cellosolve (for removal of paints, marking pen inks, lipstick, etc.) The use of masking tape, adhesive tape or link removal tools work well for lifting off old weathered paints.

To remove labels, stickers, etc., the use of kerosene or VM&P naphtha are generally effective. When the solvent will not penetrate sticker material, apply heat (hair dryer) to soften the adhesive and promote removal.

If a material is found to be incompatible in a short-term test, it will usually be found to be incompatible in the field. The converse, however, is not always true. Favorable performance is no guarantee that actual end-use conditions have been duplicated. Therefore, these results should be used as a guide only and it is recommended that the user test the products under actual end-use conditions.

MAINTENANCE

MAINTENANCE

RECOMMENDED FILLING INSTRUCTIONS FOR HYDRAULIC RESERVOIRS

When filling or checking the oil level, the unit should be parked on a level surface., shut **OFF**, and allow sufficient time to cool to ambient temperature. Use caution when removing the pressurized breather. Do not place face over opening when removing breather.

If your reservoir has two sight glasses: The reservoir should be filled to the top of the lower sight glass on the side of the tank. Do not over-fill. The reservoir has been over-filled when oil is visible in the upper sight glass. If tank has too much oil, the excess may be expelled through the pressurized breather.

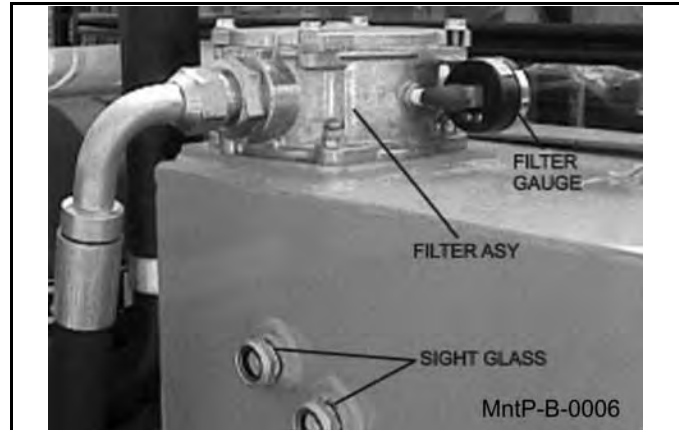

If your reservoir has one sight glass/temperature gage: The reservoir should be filled to the center of the sight glass on the side of the tank. Do not over-fill. If the tank has too much oil, the excess may be expelled through the pressurized breather.

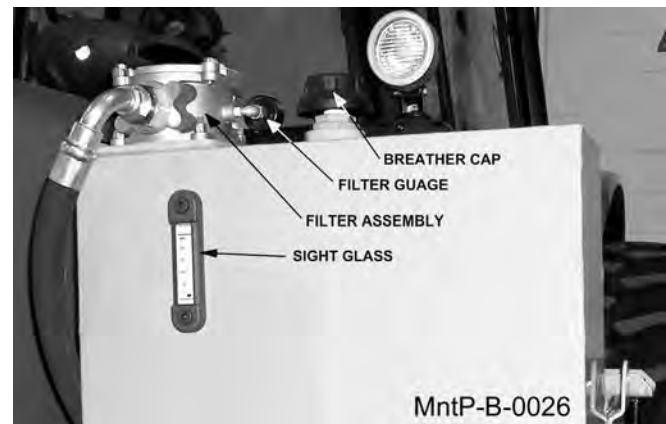

REPLACING IN-TANK HYDRAULIC FILTER

Loosen the four bolts on the top cover of the filter housing. Turn cover counter-clockwise until cover is free. Remove and replace filter. Replace top cover and cover bolts in opposite order as removed.



MAINTENANCE

REPLACING HIGH PRESSURE HYDRAULIC FILTER ELEMENT

Ensure system has been shut down and depressurized. Locate High Pressure Filter housing. Confirm that the new element matches the element p/n on the filter model tag. *Example: V3.0510-06 (world line 100, HD049 model).* Locate the bottom of the High Pressure Bowl, and using the appropriate spanner wrench or ratchet, turn in a counterclockwise rotation, (looking at the bottom of the bowl) to remove the bowl from the head. The first couple rotations will seem tight as the o-ring passes the sealing flats. Once the o-ring has cleared the sealing flats the bowl should spin freely. Taking care not to drop the bowl, finish removing the bowl from the head.



WARNING: Bowl will be full of oil! Pour the oil from the bowl into a container. This oil should be considered contaminated due to the outside-in flow direction through the element. Clean the inside of the bowl if “dirt” is present. Remove the old element from the filter head by pulling with a rotation motion. Dispose of the used element properly. Remove the new element from the packaging. Using your finger, dab and lubricate the o-ring in the top of the new element with oil. Install the new element into and on the mounting boss within the head. Ensure that the element is fully seated on the boss. Clean and inspect the o-ring that is affixed in the bowl and lubricate with oil. Using a clockwise rotation, screw the bowl back into the head, ensuring that the bowl has not been cross-threaded into the head. Continue to tighten the bowl into the head, using the spanner wrench or ratchet. The rotation of the bowl will become tighter once the o-ring engages the sealing flats. Once the bowl has bottomed out, back-off the bowl by 1/6 turn. This ensures that the o-ring is seated properly within the sealing flats. Element change out and re-assembly is now complete. Start the machine and inspect the filter area checking that there is no oil leaking from the filter assembly. The element should first be replaced at 50 hours of operation, then yearly (500 hours) or when indicated by restriction indicator.

MAINTENANCE

MAINTENANCE

GREASING THE UPPER AND LOWER SHEAVES

Locate the grease zerks on the ends of the upper and lower sheave pins as shown below. Inject Lithium-Complex Extreme Pressure grease conforming to NLGI2-ISO 320 specifications into each pin until it protrudes from the ends. These should also be greased daily or for every 8 hours of service.

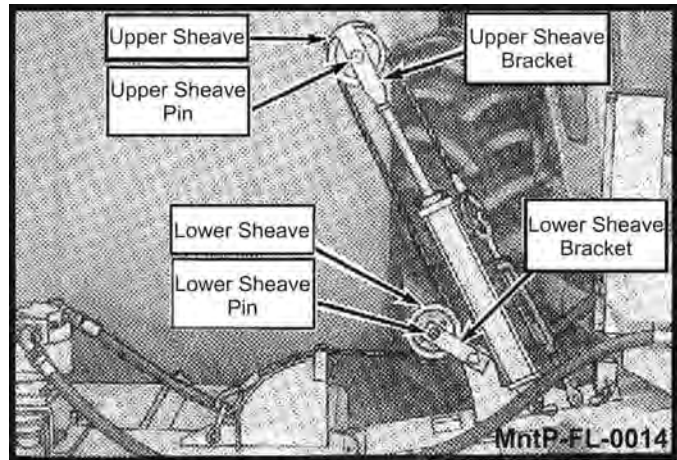

TIGHTENING BLADE BOLTS AND DISK BOLTS

After every 8 hours of operation or daily, the knife bolts and disk bolts should be tightened as follows:

Knife Mounting Bolts (3 ea.) torque to 800 oiled ft. lbs.

Disk Mounting Bolts (6 ea.) torque to 204 dry or 184 oiled ft./lbs.

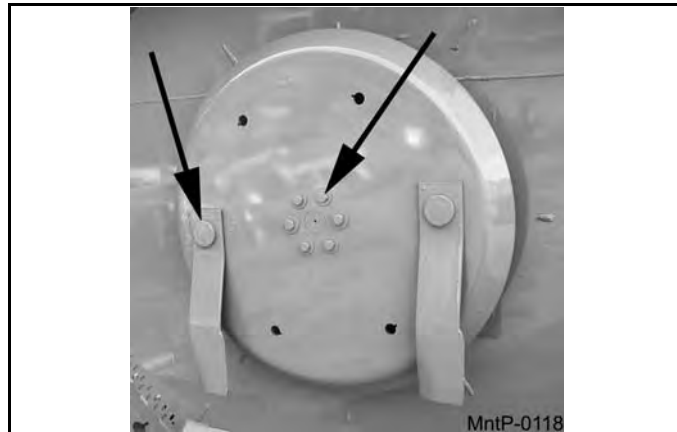

MAINTENANCE

MAINTENANCE

GREASING INNER AND OUTER DRAFT BEAM PIVOT POINTS

Locate the grease zerks on the inner and outer draft beam pivot bosses. Inject Lithium-Complex Extreme Pressure grease conforming to NLGI2-ISO 320 specifications into each zerk until grease protrudes from joints. Grease all pivots daily or every 8 hours of service.

With the cutter head lowered, locate the grease zerks on the linkage and pivot bosses. Inject Lithium-Complex Extreme Pressure grease conforming to NLGI2-ISO 320 specifications until it protrudes from the ends. With the cutter head in this position it is also possible to grease the draft beam cylinder anchors and pins. Now raise the cutter head expose the remaining zerks on the deck tilt linkages and on the other end of the cylinder.

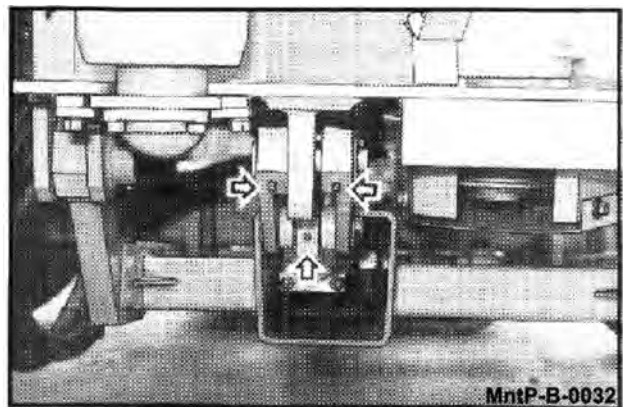
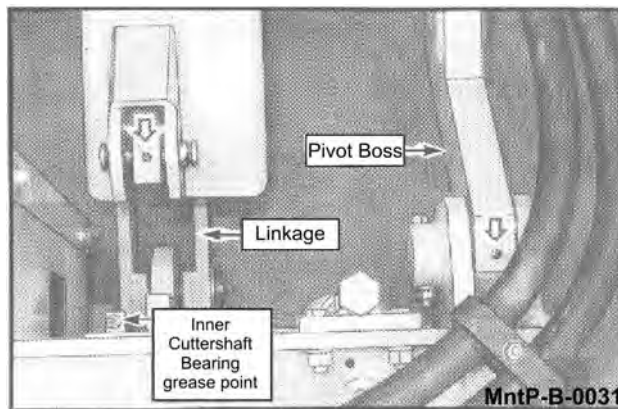
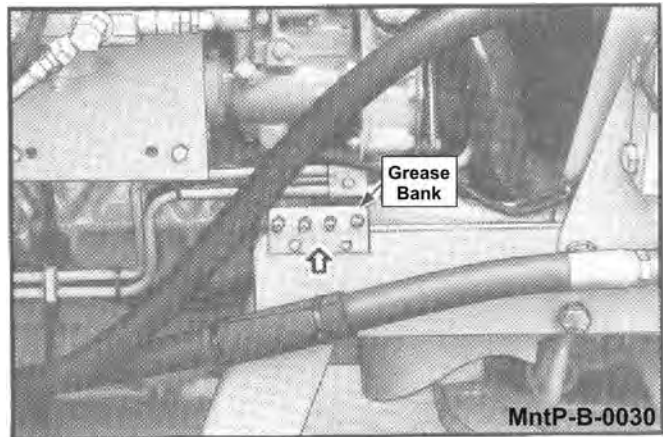

GREASING PUMP DRIVE SHAFT COUPLER

With engine stopped, ensure drive shaft alignment by grasping coupler and sliding back and forth. Coupler should slide freely with approximately 1/8" of end play. If coupler does not slide freely, inspect for loose pump mount bolts, or damaged or loose crank shaft adapter. Inject-Lithium Complex Extreme Pressure grease conforming to NLGI2-ISO 320 specifications into coupler until grease begins to protrude from ends. Grease daily or every 8 hours. Do not over grease.

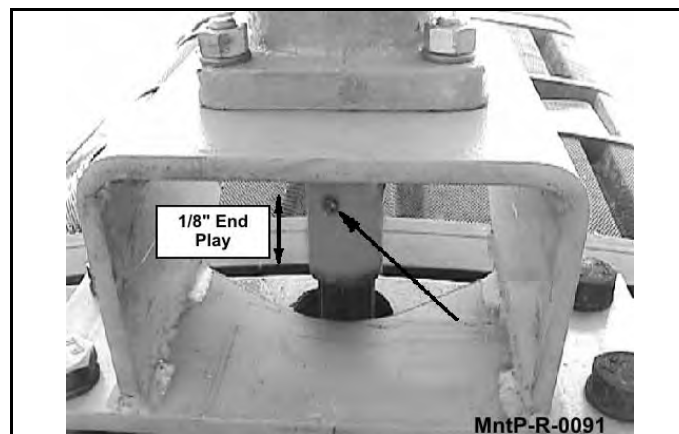

MAINTENANCE

MAINTENANCE

DRIVE SHAFT YOKE, U-JOINT & STUB SHAFT

With engine stopped, inject Lithium-Complex extreme pressure grease conforming to NLGI2-ISO 320 specifications into universal joints and slip yoke until grease appears at the seal. Grease them daily or every 8 hours.

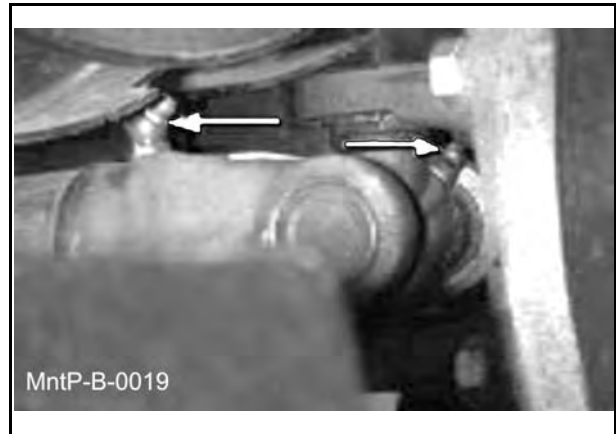

ADJUSTING THE CABLE LIFT

Extend the outboard cylinder until the mower deck touches its stop on the draft beam as shown.

NOTE: Make sure the cable turnbuckle is loose enough to allow the cylinder to reach full extension before the head reaches the stop.

Now hold the head against the stop and tighten the turnbuckle until the cable is tight. Lower and raise the head to check the adjustment. The head should touch its stop at the same time the cylinder reaches full extension. Tighten turnbuckle lock nuts securely after adjustment is complete.

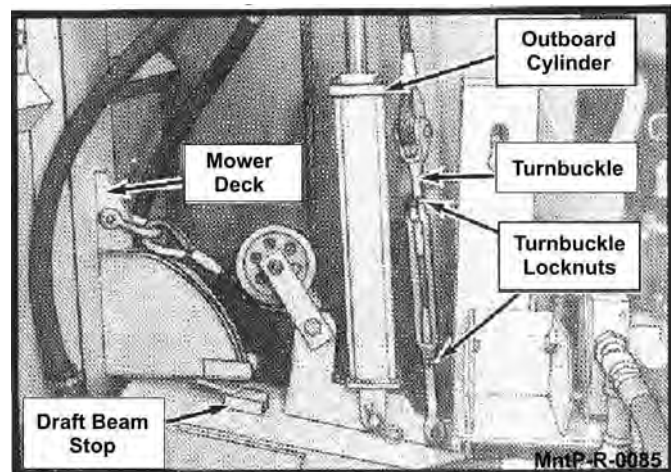

MAINTENANCE

MAINTENANCE

BALL VALVES

The ball valves at the hydraulic reservoir may need to be closed during certain maintenance or repair procedures. **THE BALL VALVES MUST BE OPEN (handle parallel with valve) WHEN TRACTOR IS RE-STARTED OR PUMP IS COUPLED TO MOTOR OR PTO!** Failure to do so will result in component failure!

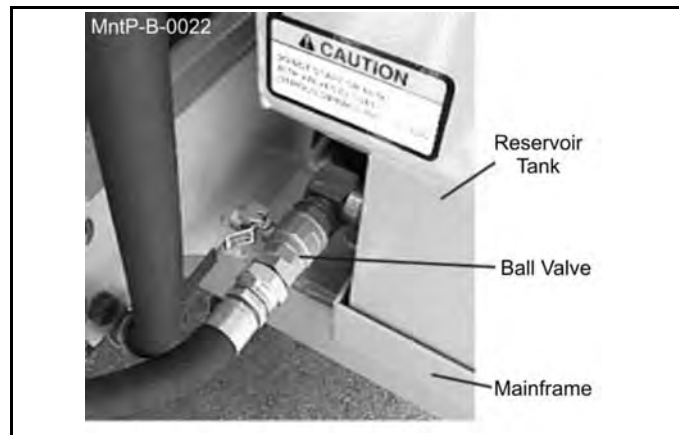

GREASING SPINDLE

Locate grease fitting on inside of deck housing. Inject Tiger Spindle Lubricant, part number 06540000 into spindle housing. Fill with lubricant until lubricant weeps out of top spindle seal. Lubricate spindle weekly or every 40 hours of use.



TIGHTENING SPINDLE BOLTS

The spindle mounting bolts should be checked and retorqued daily or every 10 hours of service. Torque the (6) bolts shown below to 331 ft. lbs.

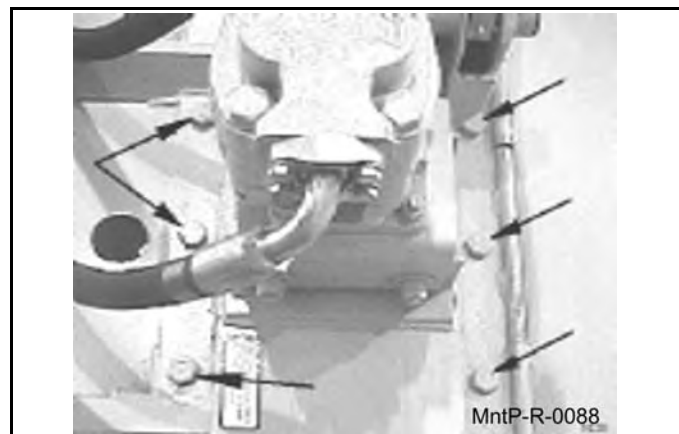

MAINTENANCE

GREASING MOTOR SPLINE TO SPINDLE SPLINE

Locate motor spline and spindle spline on the mower deck. Grease splines with Mobil moly 52. Use about 4 ounces of grease. Change grease yearly or every 500 hours.

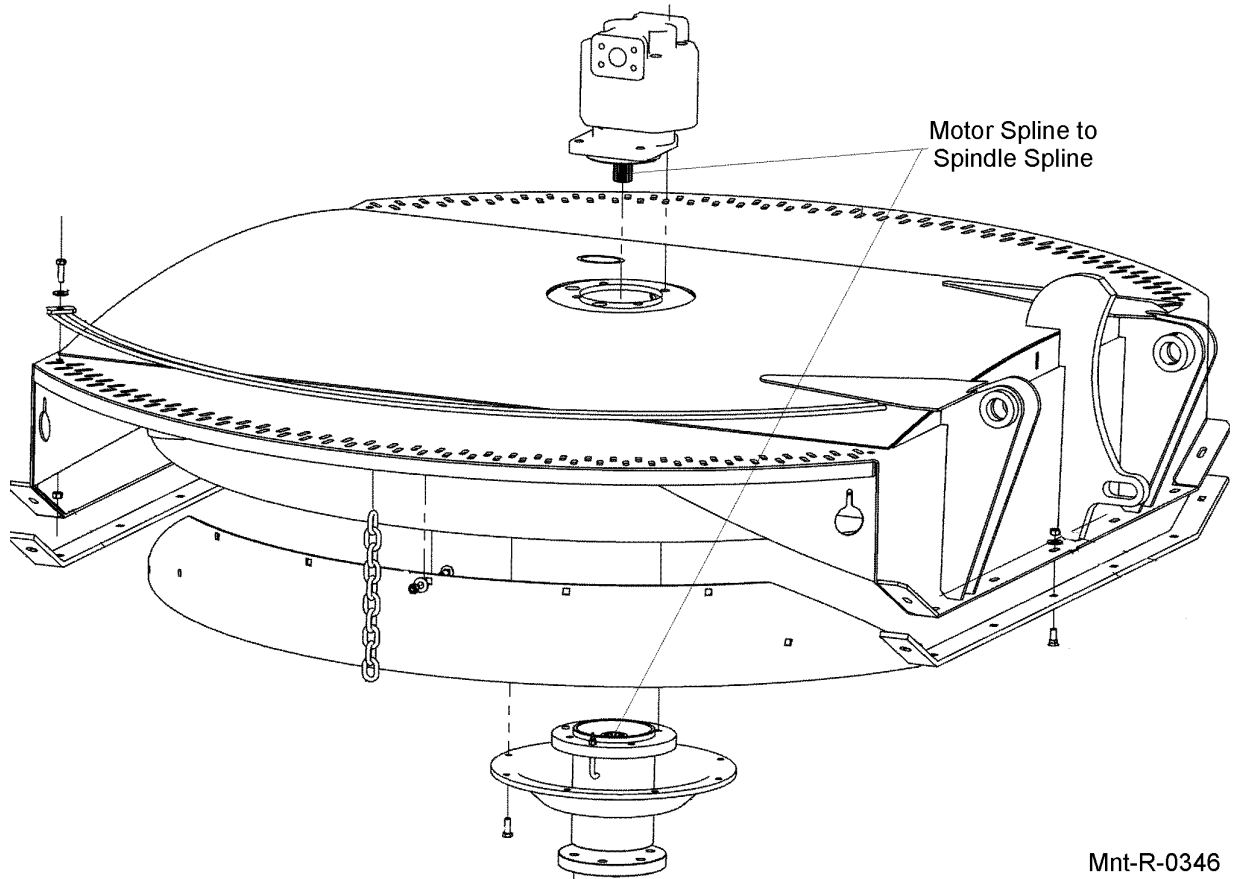

Mnt-R-0346

MAINTENANCE

MAINTENANCE

MAINTENANCE

Blades

Check the Blades for cracks and wear and Blade Bolts for tightness, daily. Blades should be replaced when they are worn excessively, bent, deformed, or out of balance.

CAUTION

Blades should always be replaced in pairs. Blades of different weights can cause serious imbalance and damage to the machine and personnel. When replacing blades, take care to replace the blade bolts, nuts, and washers.

Important

Make sure the mower blades are turning clockwise when looking down from the top of the mower. Follow the color coding on the hydraulic hoses and fittings to make sure the motor and hydraulics hoses are assembled properly. Connect the red hose connection only to red fitting. Connect the blue hose connection only to the blue fitting. The blade rotation on the leading edge of the mower should discharge the cut material away from the tractor and operator.

WARNING

If the leading edge of the mower blades are rotating backwards they can discharge material toward the operator. If this occurs discontinue mowing immediately and reverse the direction of the motor rotation by correctly installing the motor pressure and return hoses. Contact your dealer or Alamo Industrial for specific information on the hose routing.

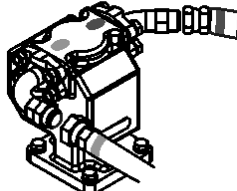

| WARNING | ADVERTENCIA |
|---|--|
| TO AVOID SERIOUS INJURY AND DEATH FROM THROWN OBJECTS: <ul style="list-style-type: none">● MAKE CERTAIN blades rotate the correct direction. | PARA EVITAR LESION SERIA O MUERTE POR OBJETOS LANZADOS: <ul style="list-style-type: none">● ASEGURE que las cuchillas giran en la dirección correcta. |
| BLADE ROTATION  ROTACIÓN DE CUCHILLAS | |
| Return Retorno BLUE |  Pressure Presión RED |

D619

MAINTENANCE

ROTARY KNIFE REPLACEMENT

1. Be sure you have a complete matching set of new knives for replacement.
2. Remove knives and inspect holes for damage. Also watch for cracks in the disk around the holes.
3. Lube threads with anti-seize, motor oil or grease. Install bolts through knife and disk from bottom side of disk. Install new self-locking nuts and torque them to 800 ft. lbs.
4. The knives should swing freely to absorb shocks from impact when striking objects.



WARNING WHEN CUTTING HEAVY BRUSH, KNIFE BOLTS SHOULD BE INSPECTED HOURLY AND RETORQUED TO 1070 DRY OR 800 OILED FT./LBS.

REPLACEMENT OF ROTARY DISK



CAUTION Failure to follow the following warnings and instructions may result in serious injury or damage to the equipment or property!

The bolts that attach the knife mounting disk to the spindle must be grade 8. These 5/8 inch fine thread series bolts are to be torqued according to the chart in this section.

A thread locking agent may be applied to threads of all mounting bolts before they are installed.

Disks must be inspected daily for hairline cracks between spindle mounting bolts or around the knife mounting bolts. These cracks indicate metal fatigue caused by severe abuse. If cracks are present, the disk must be replaced.

Inspect the disk mounting bolts daily when checking tightness of blade mounting bolts. If a disk mounting bolt is loose, it must be removed, threads cleaned, fresh thread locking agent applied, and tightened to proper torque value.

If a knife mounting bolt is loose, the self locking nut must be replaced as a safety precaution. Lubricate threads with anti-seize, grease or motor oil. Place bolts through knife and disk from bottom side of disk. Install self locking nuts and torque them to 800 ft. lbs.

1. **WARNING: The disk alone weights over 100 lbs.** Be sure its weight can be supported before attempting to replace. The use of a lift mechanism will ease replacement.
2. Remove the six disk mounting bolts and the disk from the spindle.
3. Install new disk and align with mounting bolt holes.
4. Apply a thread locking agent to all of the mounting bolts and install the bolts through the disk.
NOTE: Disk bolts must be Grade 8.
5. Tighten bolts down and torque to values noted.
6. See knife replacement instructions for replacing the knives onto the new disk.

MAINTENANCE

HEAVY DUTY SPINDLE ASSEMBLY INSTALLATION AND BEARING ADJUSTMENT



A press MUST be used to install bearing cups, bearing cones, and seals. DO NOT use a hammer to install races, bearings, or seals. The parts of assembly may be damaged.

NOTE: The grease zerk and gussets are located on the top side of the spindle housing. Be sure the spindle is assembled correctly.

Be sure to wear eye protection and other protective equipment as needed when working on spindle assembly.

THE SPINDLE ASSEMBLY

See the diagram below for identification of spindle parts, while servicing.

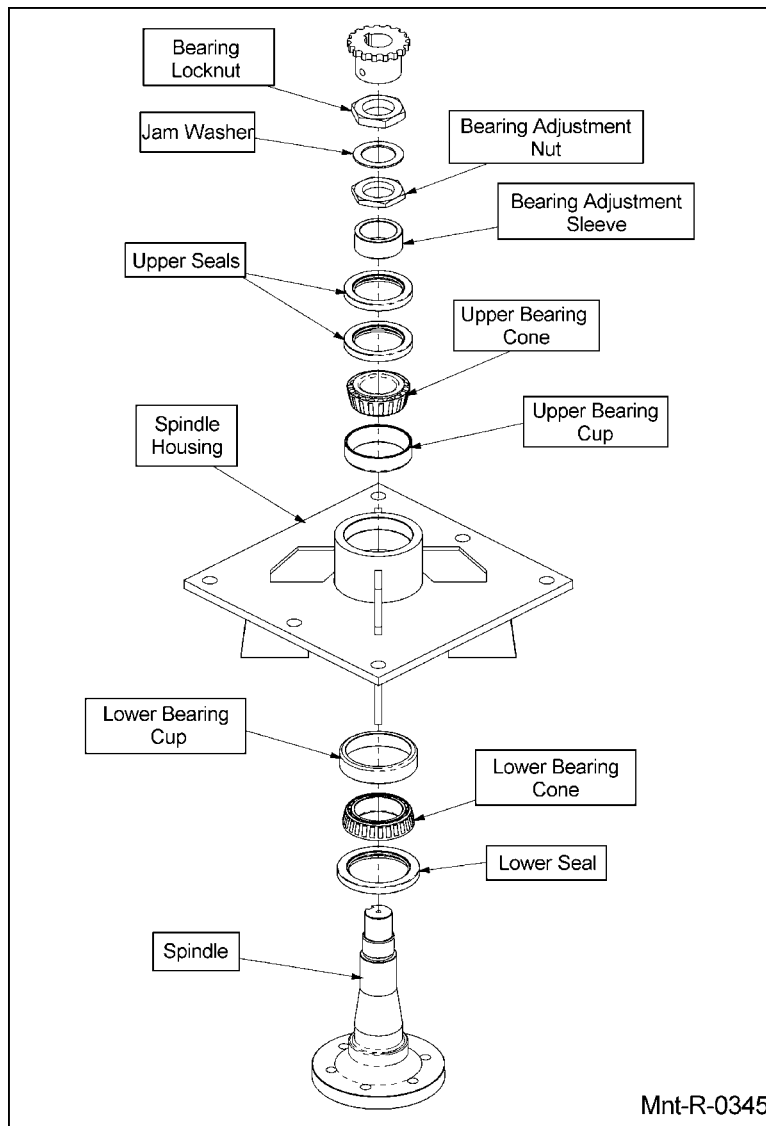

MAINTENANCE

MAINTENANCE

BEARING INSTALLATION

1. Press upper bearing cup into the spindle housing
2. Turn the spindle housing over and press in the lower bearing cup.
3. Place the lower bearing cone in the bearing cup. Next press the seal into the spindle housing. The inner lip of the seal must be DOWN, towards the bearing, so lubricant is sealed inside the housing.
4. Install the spindle in the housing. Lightly tap the end of the spindle with a soft faced hammer to seat the spindle against the bearing inner race.
5. Turn the spindle housing over (up position) and fill with Tiger Spindle Lubricant (part number 06540000) to the top edge of the upper bearing cup.
6. Support the bottom of the spindle and press the upper bearing cone and bearing adjustment sleeve onto the spindle.
NOTE: The spindle housing must turn freely when seating the bearing cone and sleeve.
7. Press the two upper seals into the spindle housing. The inner lip of the seals must be UP, away from the bearing, so excess lubricant can escape.
8. Install the bearing adjustment nut (thin nut) so there is 1-1/6" clearance between the nut and the sleeve. Install the jam washer, placing the tab into the key-way. Install the bearing lock nut (thin nut) and hand tighten against jam washer and adjustment nut. See the following section for bearing adjustment.

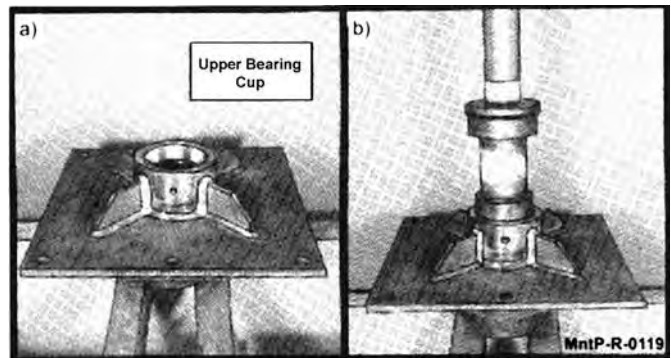

BEARING ADJUSTMENT

1. Clamp the bottom end of the spindle securely in a vise so the spindle housing turns freely.
2. Position a magnetic base dial indicator on the outer diameter of the spindle housing. Locate the end of the dial indicator against the flat end of the spindle shaft. The dial indicator will now measure accurately bearing end play.
3. Tighten the bearing adjustment nut until there is 0.012 inch movement when the spindle housing is pried upward away from the vise jaws.
4. When there is 0.012 inch free play between the spindle and housing, install the bearing lock nut (thick nut). Hold the adjusting nut securely and tighten the lock nut to 300 ft. lbs. of torque.
5. After the lock nut is tightened, there must be 0.001 inch to 0.003 inch of free play when lightly prying up on the spindle housing.

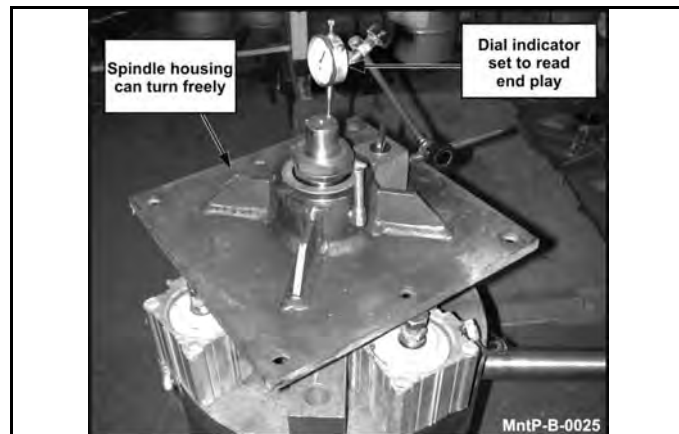

If the end play is correct, 0.001 inch to 0.003 inch, bend tabs up on jam washer to prevent the lock nut from loosening. If the end play is NOT correct, loosen the lock nut and turn the adjustment nut as required and re-tighten the lock nut. Repeat first part of step 5.

MAINTENANCE

MAINTENANCE

DAILY MAINTENANCE SCHEDULE

The following services should be performed daily or every 8 hours of service, following the detailed maintenance instructions in the operators manual.

_____ Pump Driveshaft: Check for end play in driveshaft / coupler and lubricate at zerks.

_____ Crankshaft adapter: If equipped with rubber grommets check condition, replace if missing or damaged.

_____ Pivot points: Inject grease until it appears at ends.

_____ Hydraulic fittings: Check for leaks with paper or cardboard. Tighten fittings or replace hoses immediately

_____ Knives: Inspect for missing or damaged knives, change (only complete sets) as needed.

_____ Main Frame/Deck: Unless otherwise specified retorque bolts according to torque specifications in this section.

_____ Hydraulic Fluid Level: Add, if required, per fluid recommendations.

Service performed by: _____ Date: ___/___/___ Hour

Meter: _____

Maintenance Section

**This page may be copied and used as part of the daily maintenance routine.

MAINTENANCE

MAINTENANCE OF CRANKSHAFT ADAPTER ASSEMBLY (RIGID ENGINE MOUNT TRACTORS ONLY)

If replacement of components of the crankshaft adapter assembly is required, follow the assembly procedures shown below. Seat rubber grommet completely into counterbore, then seat steel grommet completely into rubber grommet while rubber grommet is supported.

(ASM-JD-0051 CRANKSHAFT ADAPTER MAINTENANCE)

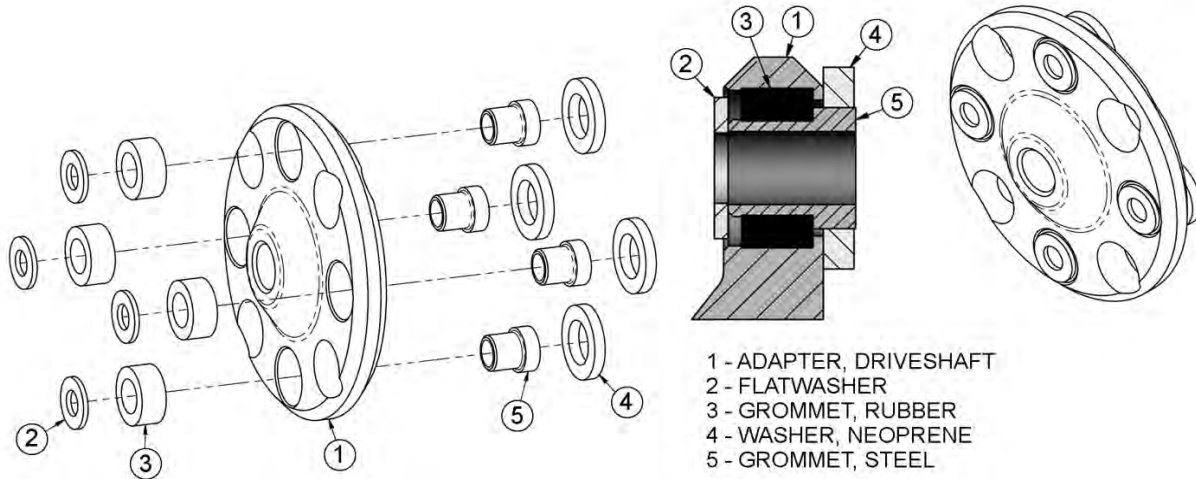

MAINTENANCE

MAINTENANCE

MAINTENANCE

PARTS SECTION

PART NAME INDEX

| | |
|--|----|
| PARTS ORDERING GUIDE..... | 3 |
| TRACTOR MOUNT KIT..... | 4 |
| TRACTOR MOUNT KIT - HYDRAULICS..... | 6 |
| DRAFT BEAM ASSEMBLY..... | 8 |
| CABLE (MANUAL) LIFT VALVE - 3 SPOOL..... | 10 |
| 3 SPOOL CABLE CONTROL MOUNT..... | 12 |
| TM REAR MOWER HYDRAULICS..... | 14 |
| TSR REAR MOWER HYDRAULICS..... | 16 |
| BATTERY RELOCATION..... | 18 |
| COOLER MOUNT..... | 20 |
| TILT CYLINDER..... | 22 |
| ZERO SPOOL VALVE OPTION..... | 23 |
| NOTES..... | 24 |

PARTS ORDERING GUIDE

The following instructions are offered to help eliminate needless delay and error in processing purchase orders for the equipment in this manual.

1. The Parts Section is prepared in logical sequence and grouping of parts that belong to the basic machine featured in this manual. Part Numbers and Descriptions are given to help locate the parts and quantities required.
2. The Purchase Order must indicate the **Name and Address** of the person or organization ordering the parts, **who should be charged**, and if possible, the **serial number of the machine** for which the parts are being ordered.
3. The purchase order must clearly list the **quantity of each part**, the complete and correct **part number**, and the basic **name of the part**.
4. The manufacturer reserves the right to substitute parts where applicable.
5. Some parts may be unlisted items which are special production items not normally stocked and are subject to special handling. Request a quotation for such parts before sending a purchase order.
6. The manufacturer reserves the right to change prices without prior notice.

NOTE: When ordering replacement decals, refer to the part numbers and descriptions listed in the safety section in the front of this manual.

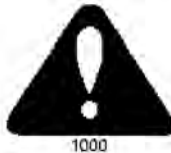

For maximum safety and to guarantee optimum product reliability, always use genuine **Tiger** replacement parts. The use of inferior replacement parts may cause premature or catastrophic failure which could result in serious injury or death.

Direct any questions regarding parts to:

Tiger Corporation
3301 N. Louise Ave.
Sioux Falls, SD 57107
1-800-843-6849
1-605-336-7900

TRACTOR MOUNT KIT

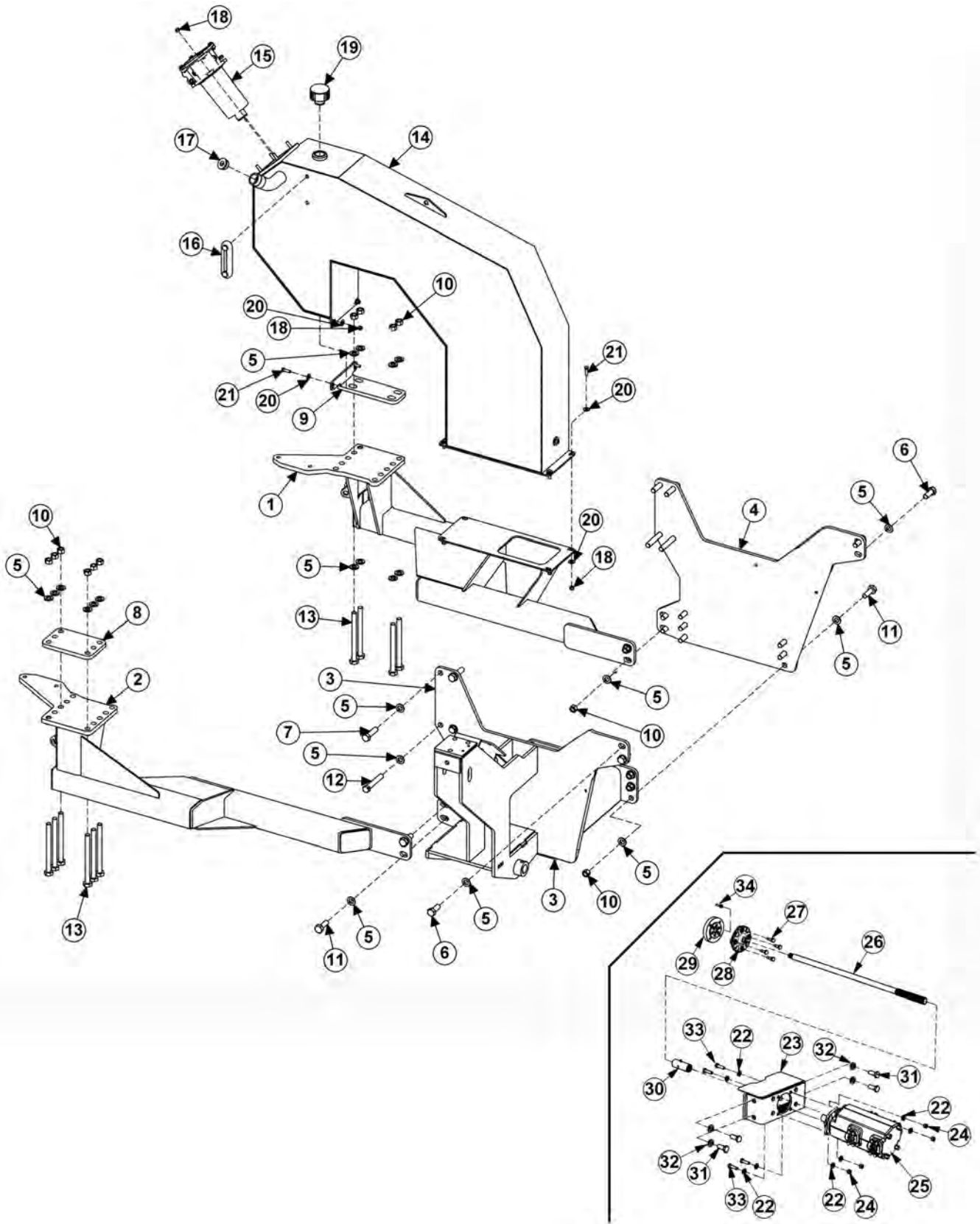

NH TS6.110 T4B TWIN ROTARY

TRACTOR MOUNT KIT

Continued...

| ITEM | PART NO. | QTY. | DESCRIPTION |
|------|----------|------|-----------------------------------|
| 1 | 06300437 | 1 | AXLE BRACE, LH, TS6.1XX T4B |
| 2 | 06300436 | 1 | AXLE BRACE, RH, TS6.1XX T4B |
| 3 | 06300441 | 1 | MAINFRAME, TM, TSF, TS6.1XX T4B |
| 4 | 06412745 | 1 | UPRIGHT, LH, TS6.1XX T4B |
| 5 | 33880 | 52 | FLATWASHER, 3/4" GR8, SAE |
| 6 | 31731 | 4 | CAPSCREW, 20MM X 50MM (2.5 PITCH) |
| 7 | 32285 | 4 | CAPSCREW, 20MM X 75MM (2.5 PITCH) |
| 8 | 06401912 | 1 | PLATE, CLAMP, AXLE, TS6.110 |
| 9 | 06380082 | 1 | MOUNT, 06380078 |
| 10 | 21825 | 20 | HEX NUT, 3/4" NC |
| 11 | 21833 | 10 | CAPSCREW, 3/4" X 2-1/4" NC |
| 12 | 06530537 | 4 | CAPSCREW, 20MM X 120MM |
| 13 | 21846 | 10 | CAPSCREW, 3/4" X 9" NC |
| 14 | 06700215 | 1 | TANK, RES, WW, TS6.1XX T4B |
| 15 | 06505044 | 1 | FILTER |
| 16 | 06505067 | 1 | SIGHT GAGE |
| 17 | 06505127 | 1 | PLUG, SAE #20 |
| 18 | 21627 | 10 | NYLOCK NUT, 3/8" NC |
| 19 | 06505077 | 1 | CAP, BREATHER |
| 20 | 22016 | 12 | FLATWASHER, 3/8" GR8 |
| 21 | 21631 | 6 | CAPSCREW, 3/8" X 1-1/4" NC GR8 |
| 22 | 06533004 | 8 | FLATWASHER, 1/2" |
| 23 | 06380042 | 1 | MOUNT, PUMP |
| 24 | 21725 | 4 | HEX NUT, 1/2" NC |
| 25 | 06504002 | 1 | PUMP, TANDEM |
| 26 | 06420187 | 1 | DRIVESHAFT |
| 27 | 06535000 | 4 | CAPSCREW, 7/16" X 1-1/4" CUT OFF |
| 28 | 6T0389 | 1 | ADAPTER, DRIVESHAFT, NH ASSY |
| 29 | 06420144 | 1 | SPACER, CRANKSHAFT |
| 30 | 6T0375B | 1 | COUPLING, 14 SPLINE, W/ZERK |
| 31 | 31731 | 8 | CAPSCREW, 20MM X 50MM (2.5) 10.9 |
| 32 | 33880 | 46 | FLATWASHER, 3/4" |
| 33 | 21732 | 4 | CAPSCREW, 1/2" X 1-3/4" NC |
| 34 | ---- | - | *EXISTING HARDWARE* |

TRACTOR MOUNT KIT - HYDRAULICS

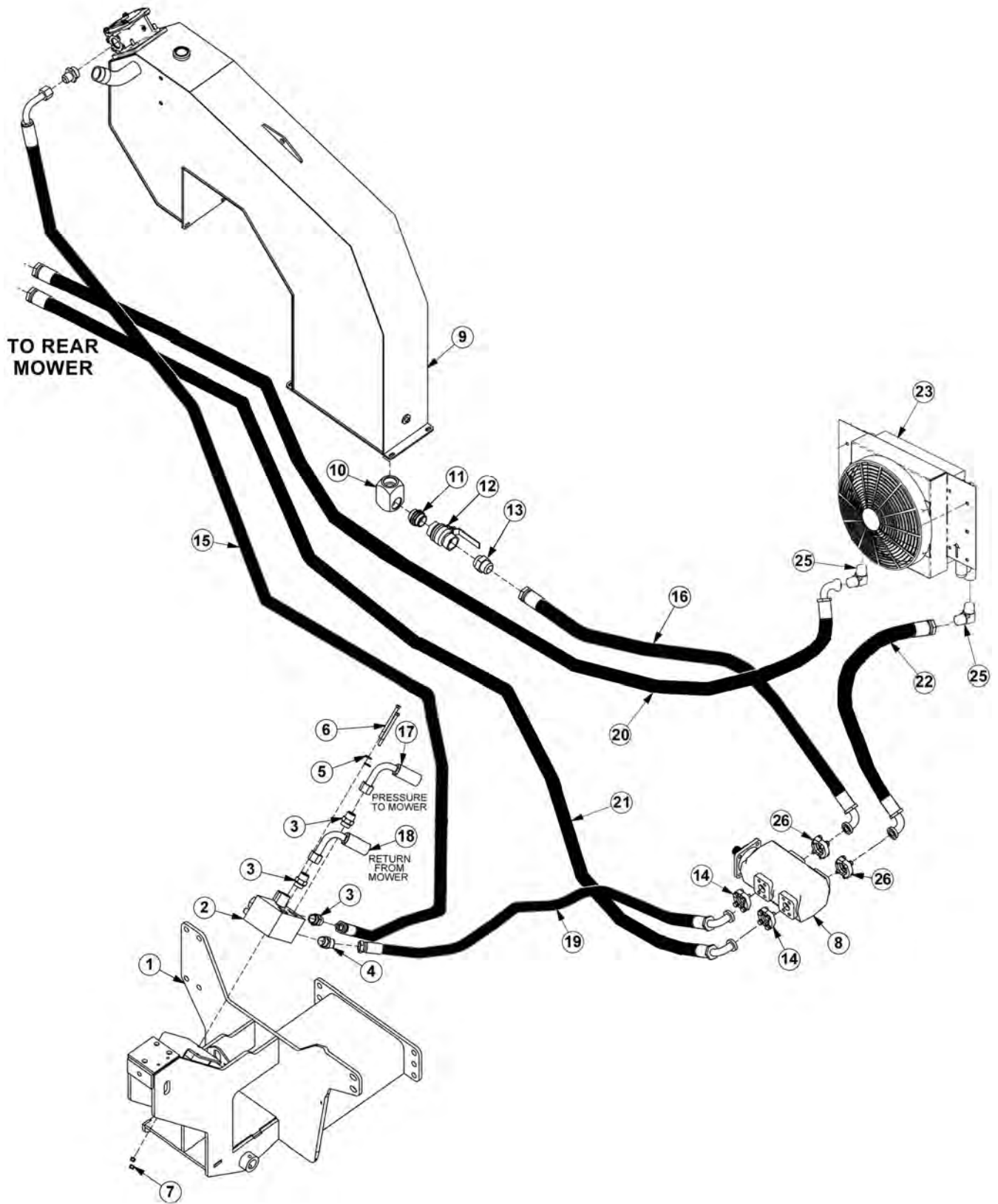

NH TS6.110 T4B TWIN ROTARY

TRACTOR MOUNT KIT - HYDRAULICS

Continued...

| ITEM | PART NO. | QTY. | DESCRIPTION |
|------|----------|------|--------------------------------|
| 1 | 06300441 | 1 | MAINFRAME, SIDE MOWER |
| 2 | 06510083 | 1 | BRAKE VALVE |
| 3 | 33555 | 3 | ADAPTER, 1"MB X 1"MJ |
| 4 | 33554 | 1 | ELBOW, 1"ORB X 1" FJX 45° |
| 5 | 22016 | 2 | FLATWASHER, 3/8" GR8 |
| 6 | 21644 | 2 | CAPSCREW, 3/8" X 5" NC |
| 7 | 21627 | 2 | NYLOCK NUT, 3/8" NC |
| 8 | 06504002 | 1 | PUMP, TANDEM |
| 9 | 06700215 | 1 | TANK, RES, TS6.1XX T4B |
| 10 | 06503084 | 1 | ELBOW, 1-1/2" FOR X 1-1/2" FOR |
| 11 | 06503083 | 1 | ADAPTER, 1-1/2"ORB X 1-1/2"ORB |
| 12 | 34309 | 1 | BALL VALVE |
| 13 | 34710 | 1 | ADAPTER, 1-1/2"ORB X 1-1/2"MJ |
| 14 | 34064 | 1 | ADAPTER, 1-1/4" MOR X 1"MJ |
| 15 | 06500445 | 1 | HOSE, 1" X 145" |
| 16 | 06500918 | 1 | HOSE, 1-1/2" X 114" |
| 17 | --- | 1 | HOSE, PRESSURE TO MOWER |
| 18 | ---- | 1 | HOSE, RETURN FROM MOWER |
| 19 | 34044 | 1 | HOSE, 1" X 73" |
| 20 | 06500850 | 1 | HOSE, 1" X 164" |
| 21 | 06500756 | 1 | HOSE, 1" X 165" |
| 22 | 06500778 | 1 | HOSE, 1-1/4" X 38" |
| 23 | 06510350 | 1 | COOLER |
| 25 | 34117 | 2 | ELBOW, 1"MB X 1"MJ |
| 26 | TF4854 | 2 | FLANGE KIT #24 |

DRAFT BEAM ASSEMBLY

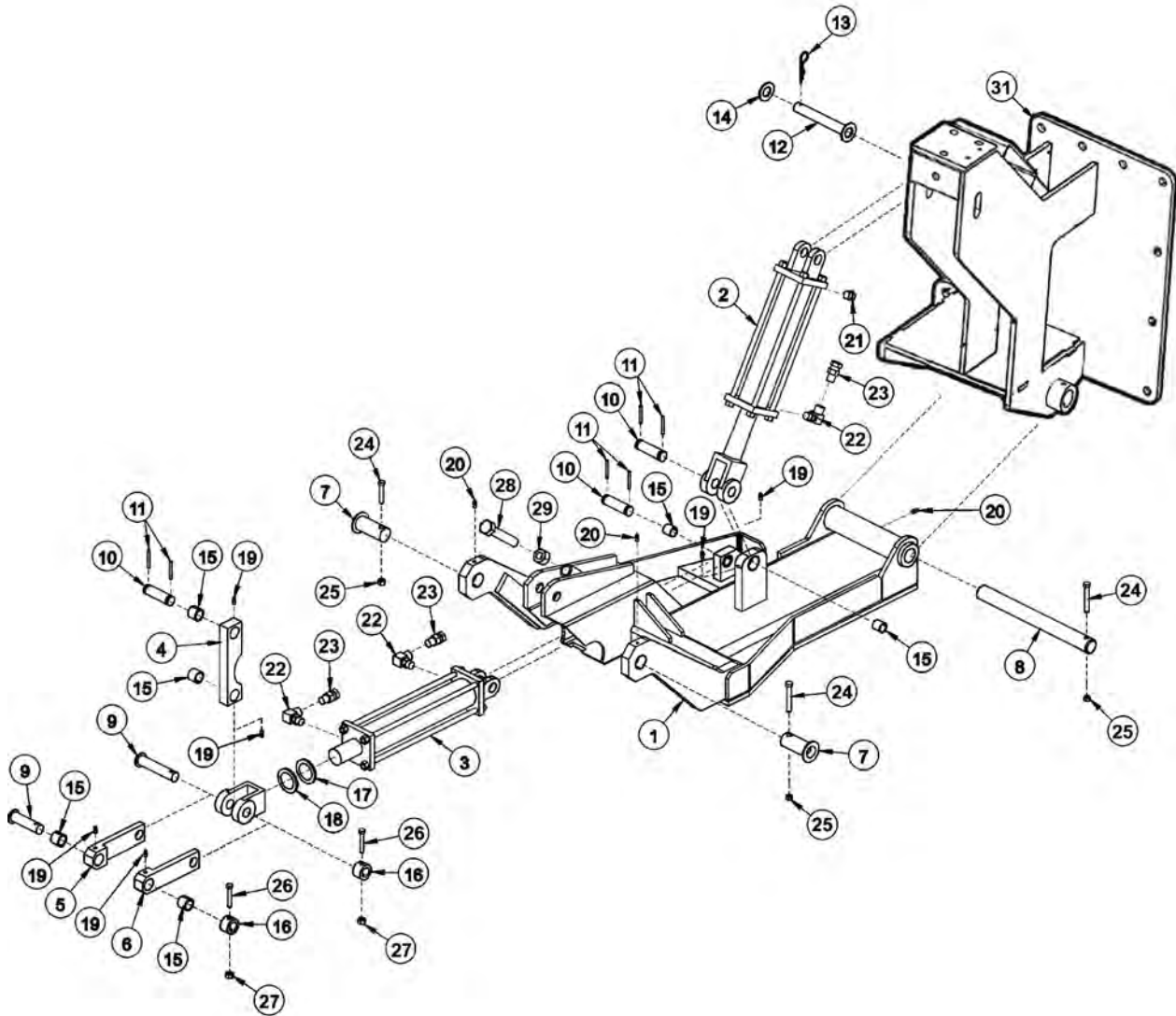

DRAFT BEAM ASSEMBLY

Continued...

| ITEM | PART NO. | QTY. | DESCRIPTION |
|------|----------|------|--|
| 1 | 06350032 | 1 | DRAFT BEAM |
| 2 | 6T10151R | 1 | HYD CYLINDER, 3" X 10" |
| 3 | 25343 | 1 | HYD CYLINDER, 3" X 12" |
| 4 | TF4500A | 1 | PIVOT ARM |
| 5 | TF4507B | 1 | RIGHT LINKAGE ARM |
| 6 | TF4506B | 1 | LEFT LINKAGE ARM |
| 7 | TF4514A | 2 | PIN, HEAD PIVOT |
| 8 | 6T3001 | 1 | PIN, BEAM PIVOT |
| 9 | TF4519 | 2 | PIN, LINKAGE |
| 10 | TB1033 | 3 | PIN, CLEVIS |
| 11 | 06537021 | 6 | ROLLPIN |
| 12 | 6T3005 | 1 | PIN, 1" W/CAP |
| 13 | 6T3004 | 1 | R-CLIP HAIRPIN |
| 14 | 22023 | 1 | FLATWASHER, 1" |
| 15 | TB3010 | 8 | BUSHING, 1" |
| 16 | 22847A | 2 | BOSS, LINKAGE PIN |
| 17 | 22076 | 1 | SPACER, HYD CYLINDER 1/4" |
| 18 | 06430147 | 1 | SPACER, HYD CYLINDER |
| 19 | 6T3207 | 6 | GREASE ZERK, 1/4" |
| 20 | 6T3211 | 3 | GREASE ZERK, 1/8" |
| 21 | 6T4258 | 1 | BREATHER, 1/2" |
| 22 | 34244 | 3 | ELBOW FITTING, 1/2" |
| 23 | 34396 | 3 | SWIVEL RESTRICTOR |
| 24 | 21688 | 3 | CAPSCREW, 7/16" X 3-1/4" |
| 25 | 21677 | 3 | NYLOCK NUT 7/16" |
| 26 | 21635 | 2 | CAPSCREW, 3/8" X 2-1/4" |
| 27 | 21627 | 2 | NYLOCK NUT 3/8" |
| 28 | 21831 | 1 | CAPSCREW, 3/4" X 1-3/4" |
| 29 | 21825 | 1 | HEX NUT, 3/4" |
| 31 | ---- | - | MAINFRAME *REFER TO TRACTOR MOUNT PAGE |

CABLE (MANUAL) LIFT VALVE - 3 SPOOL

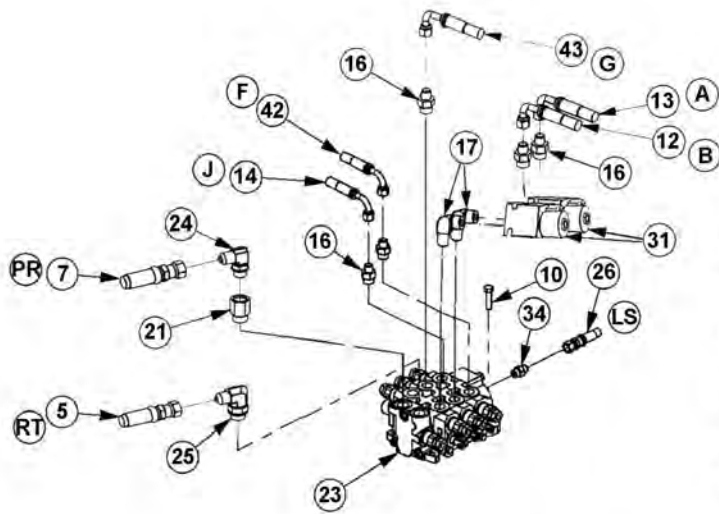

HOSE ROUTING

- A - TO OUTBOARD CYLINDER BUTT
- B - TO INBOARD CYLINDER GLAND
- F - TO TILT CYLINDER BUTT
- G - TO TILT CYLINDER GLAND
- J - TO OUTBOARD CYLINDER GLAND
- LS - LIFT VALVE LOAD SENSE TO TRACTOR
- TL - TRACTOR LOAD SENSE
- PR - PRESSURE FROM TRACTOR
- RT - RETURN TO TRACTOR

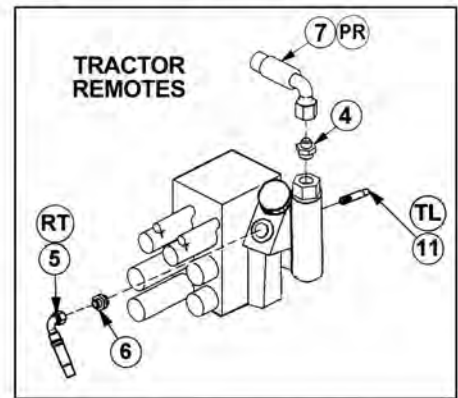
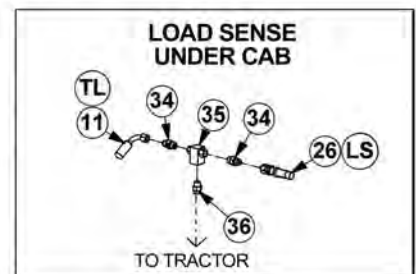
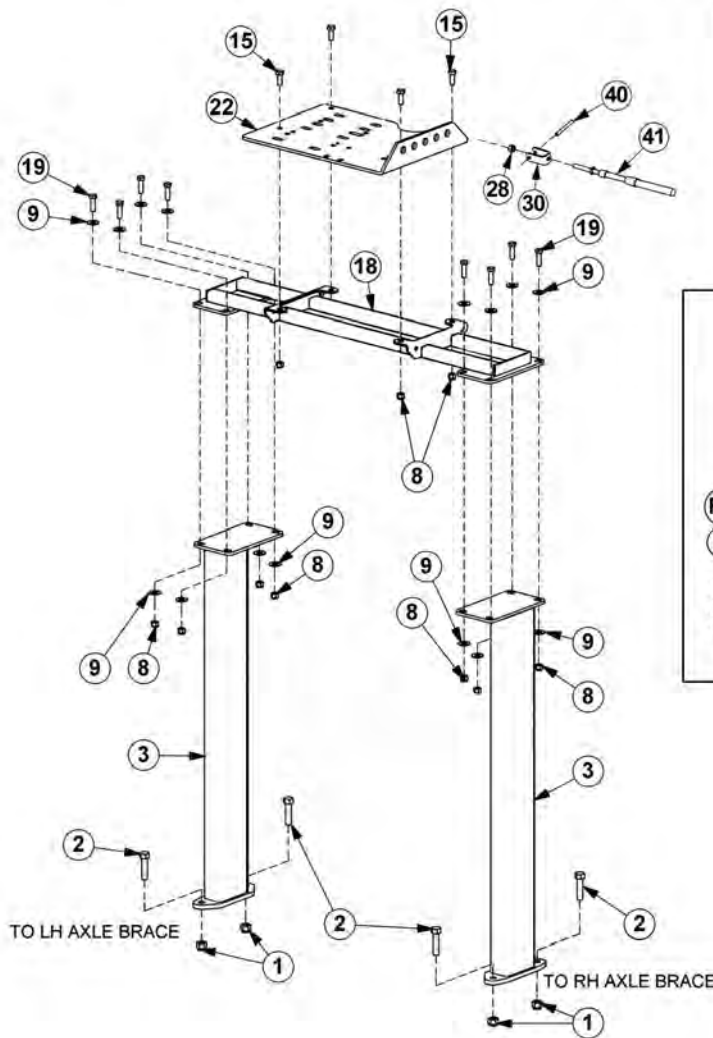

CABLE (MANUAL) LIFT VALVE - 3 SPOOL

Continued...

| ITEM | PART NO. | QTY. | DESCRIPTION |
|------|----------|------|--------------------------------|
| 1 | 21727 | 4 | NYLOCK NUT, 1/2" NC |
| 2 | 21733 | 4 | CAPSCREW, 1/2" X 2" NC |
| 3 | 06340056 | 2 | VLV MNT, LEG, TS6.1XX, T4B |
| 4 | 06503167 | 1 | ADAPTER, BANJO, 3/4 |
| 5 | 33410 | 1 | HOSE, 1/2" X 48" RETURN |
| 6 | 06503059 | 1 | ADAPTER, 5/8" MJ X 3/4" |
| 7 | 06500339 | 1 | HOSE, 1/2" X 35" PRESSURE |
| 8 | 21627 | 11 | NYLOCK NUT, 3/8" NC |
| 9 | 22016 | 16 | FLATWASHER, 3/8", GR8 |
| 10 | 21632 | 3 | CAPSCREW, 3/8 X 1-1/2 NC |
| 11 | 34633 | 1 | HOSE, 1/4" X 66" |
| 12 | 34632 | 1 | HOSE, 1/4" X 115" |
| 13 | 34631 | 1 | HOSE, 1/4" X 126" |
| 14 | 06500311 | 1 | HOSE, 1/4" X 156" |
| 15 | 21630 | 6 | CAPSCREW, 3/8 X 1 NC |
| 16 | 33271 | 5 | ADAPTER, 1/2" MOR X 3/8" MJ |
| 17 | 33382 | 2 | ELBOW, 1/2" MB X 1/2" MJ |
| 18 | 06340057 | 1 | VLV MNT, TS6.1XX, T4B |
| 19 | 21631 | 11 | CAPSCREW, 3/8 X 1 1/4, NC, GR8 |
| 21 | 32678 | 1 | ADAPTER, 5/8" ORB X 1/2" FOR |
| 22 | 34622 | 1 | PLATE, VALVE, REAR MNT |
| 23 | 06502044 | 1 | VLV, 3SP, HSC2 |
| 24 | 33293 | 1 | ELBOW, 1/2" MOR X 1/2" MJ |
| 25 | 33383 | 1 | ELBOW, 5/8" MB X 1/2" MJ |
| 26 | 06500450 | 2 | HOSE, 1/4" X 42" |
| 28 | 21500 | 1 | HEX NUT, 1/4 NF |
| 30 | 6T4411 | 1 | CLEVIS, CABLE CONTROL |
| 31 | 06510050 | 2 | TRV LCK, METRIPACK COIL |
| 34 | 32901 | 2 | ADAPTER, 3/8" MOR X 3/8" MJ |
| 35 | 3338806 | 1 | TEE, SHUTTLE, 3/8" FOR |
| 36 | 06503166 | 1 | ADAPTER, 3/8" MB X 1/4" FJX |
| 40 | 6T3017 | 3 | ROLL PIN, CABLE CONTROL |
| 41 | 06505100 | 3 | CABLE CONTROL 108" |
| 42 | 34634 | 1 | HOSE, 1/4" X 66" |
| 43 | 06500594 | 1 | HOSE, 1/4" X 28" |

3 SPOOL CABLE CONTROL MOUNT

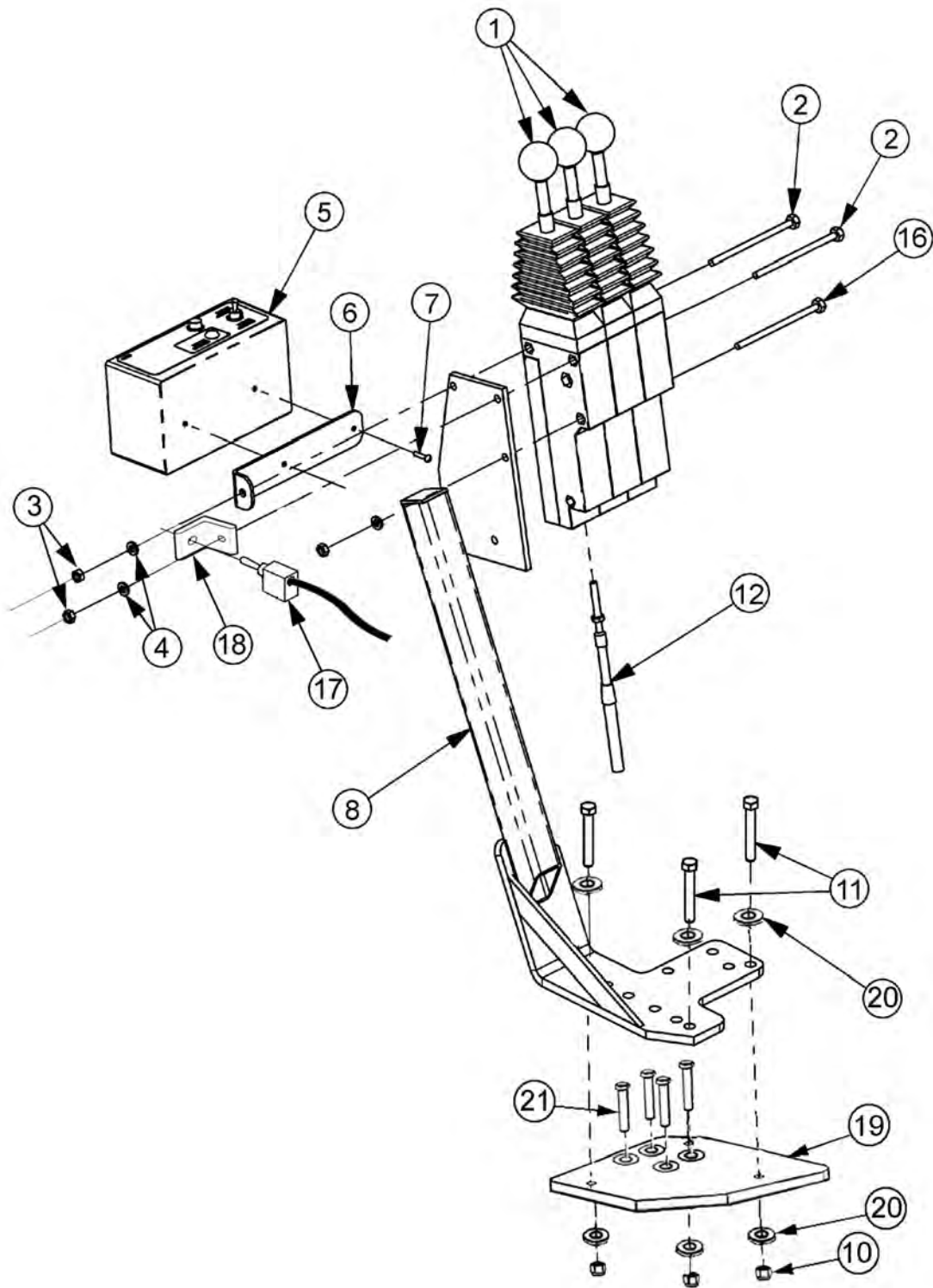

3 SPOOL CABLE CONTROL MOUNT

Continued...

| ITEM | PART NO. | QTY. | DESCRIPTION |
|------|----------|------|-----------------------------------|
| 1 | 6T1251 | 3 | CBL CTRL BOX,180 DEG |
| 2 | 22903 | 2 | CAPSCREW,1/4" X 5-1/2",NC, GR5 |
| 3 | 21527 | 3 | NYLOCK NUT,1/4" |
| 4 | 21986 | 3 | LOCKWASHER,1/4" |
| 5 | 06510102 | 1 | SWITCHBOX,SIDE,GND |
| 6 | 34496 | 1 | BRKT,SWITCHBOX,UNI |
| 7 | 6T3951 | 2 | SCREW,MACHINE,8-32 X 1/2" |
| 8 | 23865B | 1 | CBL CTRL MT BRKT |
| 10 | 21627 | 7 | NYLOCK NUT,3/8",NC |
| 11 | 21632 | 3 | CAPSCREW,3/8" X 1-1/2" NC |
| 12 | 06505100 | 3 | CBL,CNTRL,108" |
| 16 | 21545 | 1 | CAPSCREW, 1/4" X 6" NC |
| 17 | 34532 | 1 | SWITCH, TRAVEL LOCK |
| 18 | 34874 | 1 | BRACKET, SWITCH |
| 19 | 06380081 | 1 | MOUNT, STAND, CONTROL TS6.1XX T4B |
| 20 | 22015 | 6 | FLATWASHER, 5/16" |
| 21 | 06530108 | 4 | CAPSCREW, 8MM X 70MM, 1.25 |

TM REAR MOWER HYDRAULICS

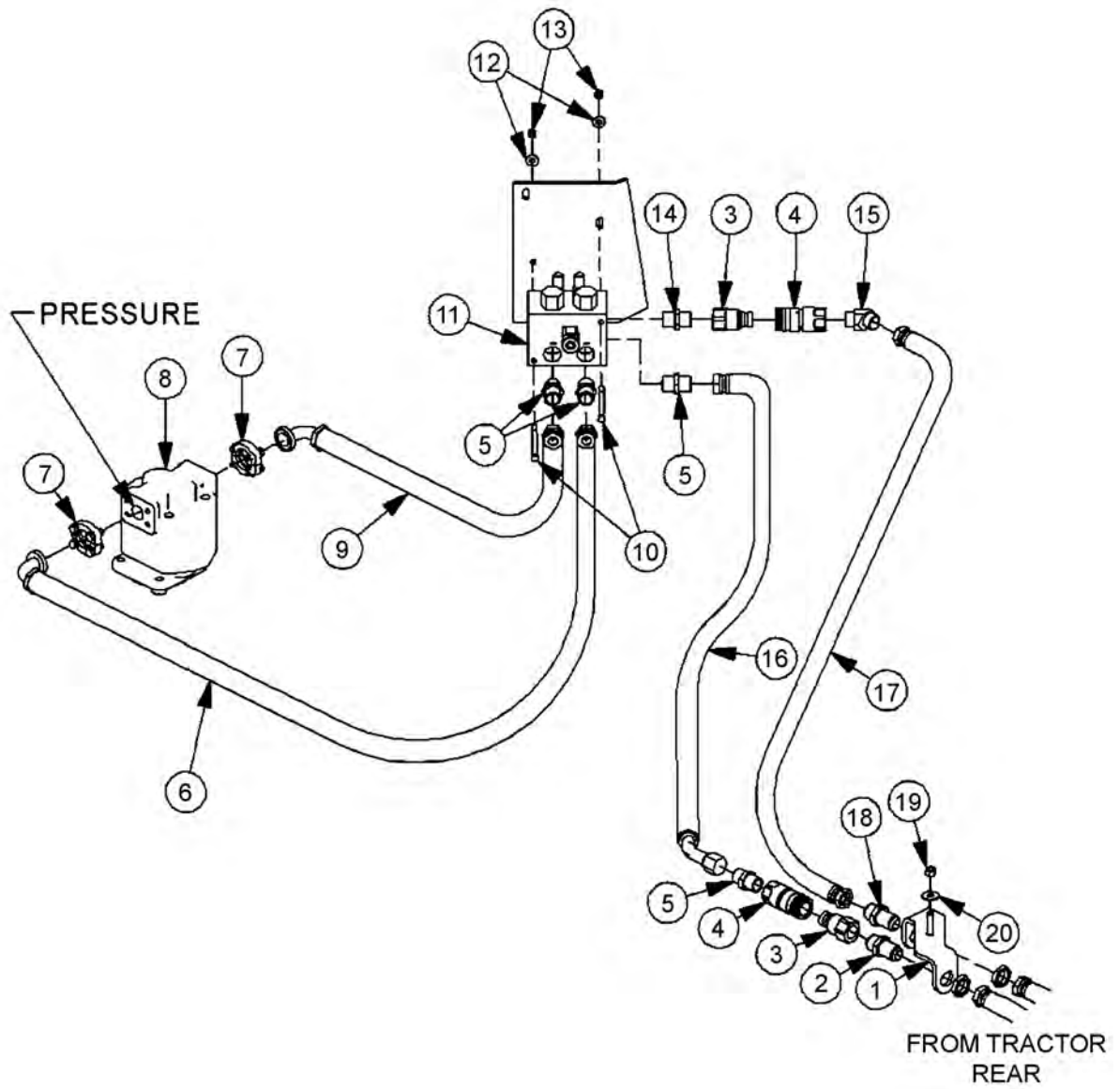

TM REAR MOWER HYDRAULICS

Continued...

| ITEM | PART NO. | QTY. | DESCRIPTION |
|------|----------|------|---------------------------------------|
| 1 | 34181 | 1 | UNION BLOCK,TRR |
| 2 | 33287 | 1 | FITTING,BULKHEAD,1"MJ X 1"MOR |
| 3 | 06503028 | 2 | QUICK COUPLER,1"SAE,MALE,FLAT |
| 4 | 06503027 | 2 | QUICK COUPLER,1"SAE,FEM,FLAT |
| 5 | 33555 | 5 | ADAPTER,1"MOR X 1"MJ |
| 6 | 34198 | 1 | HOSE,1" X 40" (PRESSURE) |
| 7 | TF4852 | 2 | KIT,FLANGE,#20 |
| 8 | ----- | - | PUMP *REFER TO TRACTOR MOUNT KIT PAGE |
| 9 | 34197 | 1 | HOSE,1" X 33" (RETURN) |
| 10 | 21644 | 2 | CAPSCREW,3/8" X 5",NC |
| 11 | 06510083 | 1 | VALVE,BRAKE |
| 12 | 22016 | 2 | FLATWASHER,3/8" |
| 13 | 21625 | 2 | HEX NUT,3/8",NC |
| 14 | 06503074 | 1 | UNION,1"MOR X 1"MOR |
| 15 | 33554 | 1 | ELBOW 1"MOR X 1"MJ 45° |
| 16 | 06500104 | 1 | HOSE,1" X 64" |
| 17 | 34865 | 1 | HOSE,1" X 57" |
| 18 | 34183 | 1 | ADAPTER,BULKHEAD,1"MJ X 1"MJ |
| 19 | 21725 | 1 | HEX NUT,1/2",NC |
| 20 | 22018 | 1 | FLATWASHER,1/2",WIDE |

TSR REAR MOWER HYDRAULICS

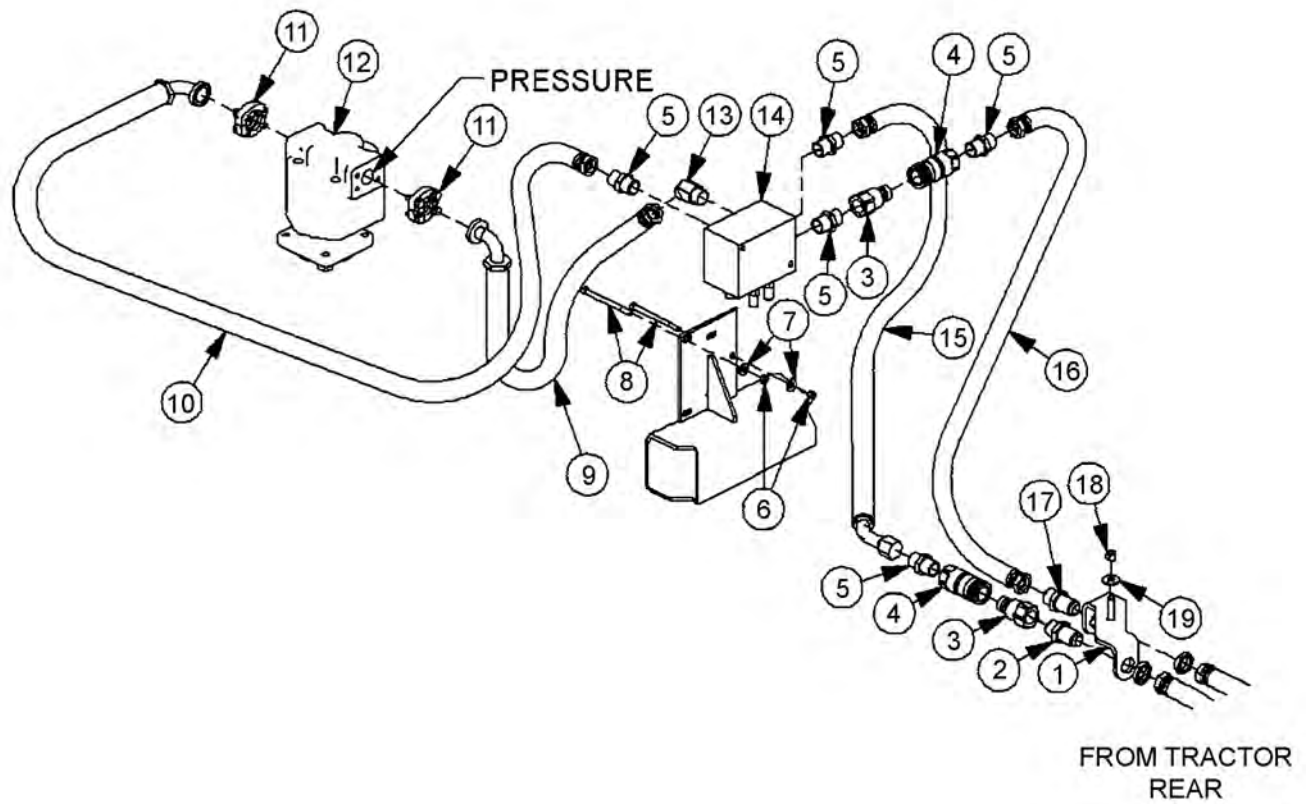

TSR REAR MOWER HYDRAULICS

Continued...

| ITEM | PART NO. | QTY. | DESCRIPTION |
|------|----------|------|---------------------------------------|
| 1 | 34181 | 1 | UNION BLOCK,TRR |
| 2 | 33287 | 1 | FITTING,BULKHEAD,1"MJ X 1"MOR |
| 3 | 06503028 | 2 | QUICK COUPLER,1"SAE,MALE,FLAT |
| 4 | 06503027 | 2 | QUICK COUPLER,1"SAE,FEM,FLAT |
| 5 | 33555 | 5 | ADAPTER,1"MOR X 1"MJ |
| 6 | 21625 | 2 | HEX NUT,3/8",NC |
| 7 | 22016 | 2 | FLATWASHER,3/8" |
| 8 | 21644 | 2 | CAPSCREW,3/8" X 5",NC |
| 9 | 06500086 | 1 | HOSE,1" X 24" (PRESSURE) |
| 10 | 06500087 | 1 | HOSE,1" X 42" (RETURN) |
| 11 | TF4852 | 2 | KIT,FLANGE,#20 |
| 12 | ----- | - | PUMP *REFER TO TRACTOR MOUNT KIT PAGE |
| 13 | 33554 | 1 | ELBOW 1"MOR X 1"MJ 45° |
| 14 | 06510083 | 1 | VALVE,BRAKE |
| 15 | 06500104 | 1 | HOSE,1" X 64" |
| 16 | 34865 | 1 | HOSE,1" X 57" |
| 17 | 34183 | 1 | ADAPTER,BULKHEAD,1"MJ X 1"MJ |
| 18 | 21725 | 1 | HEX NUT,1/2",NC |
| 19 | 22018 | 1 | FLATWASHER,1/2",WIDE |

BATTERY RELOCATION

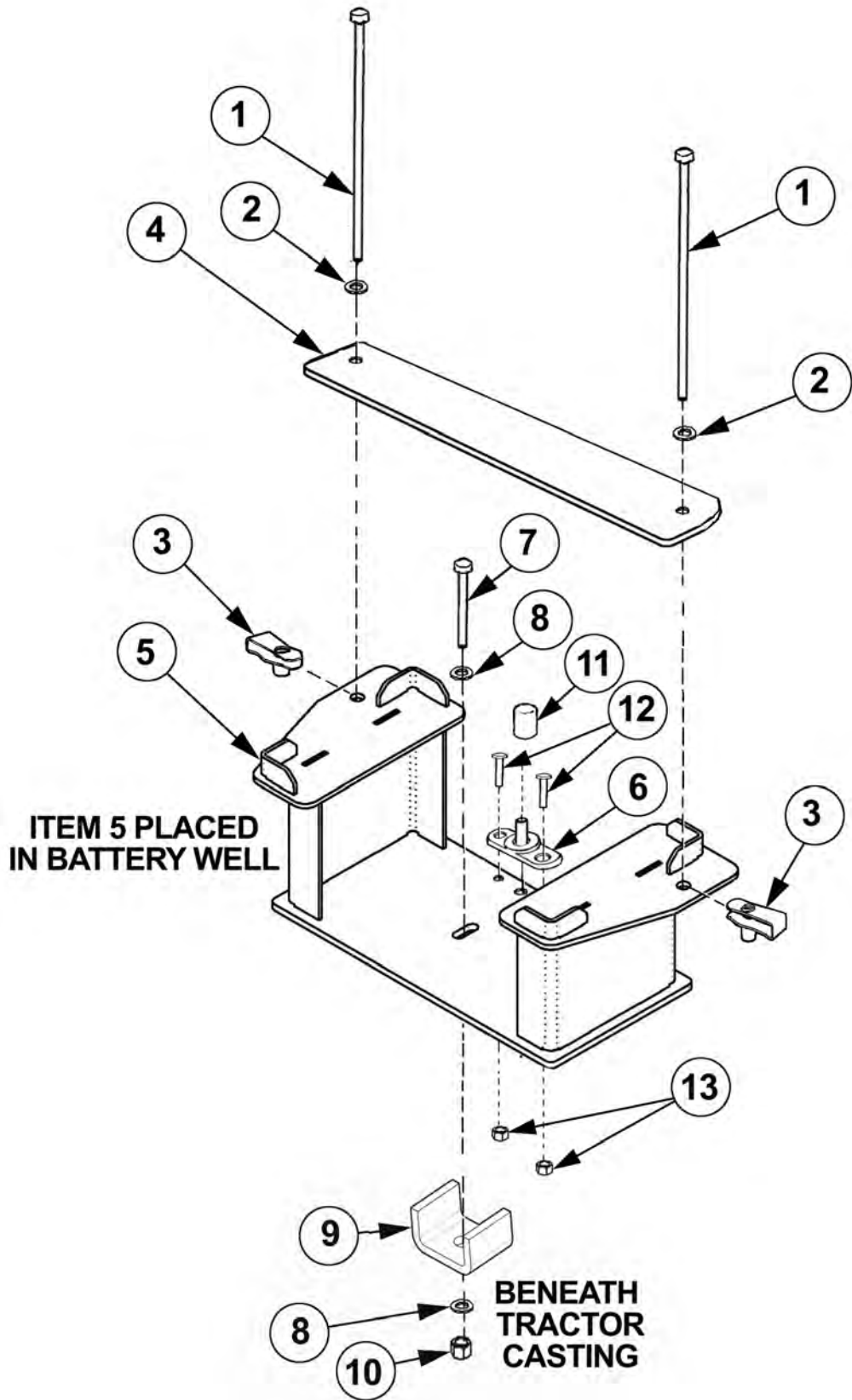

BATTERY RELOCATION

Continued...

| ITEM | PART NO. | QTY. | DESCRIPTION |
|------|----------|------|-------------------------------|
| 1 | 06530234 | 2 | CAPSCREW, 1/4" X 10" NC |
| 2 | 22014 | 2 | FLATWASHER, 1/4" |
| 3 | 35176 | 2 | U-NUT, 1/4" 3/4" TO CENTER |
| 4 | 06412376 | 1 | BATTERY STRAP |
| 5 | 06370267 | 1 | RELOC, BATT, NH TS6 T4B |
| 6 | 06512019 | 1 | JUNCTION BLOCK, 3/8 STUD, RED |
| 7 | 21587 | 1 | CAPSCREW, 5/16" X 2-3/4" NC |
| 8 | 22015 | 2 | FLATWASHER, 5/16" |
| 9 | 06412377 | 1 | CLAMP, BATTERY, BTM, TS6 T4B |
| 10 | 21577 | 1 | NYLOCK NUT, 5/16" NC |
| 11 | 06510261 | 1 | POST, BATTERY, POS |
| 12 | 06530304 | 2 | SCREW, MACHINE, 10-24 X 3/4" |
| 13 | 24890 | 2 | HEX NUT, 10-24, NYLOCK |

COOLER MOUNT

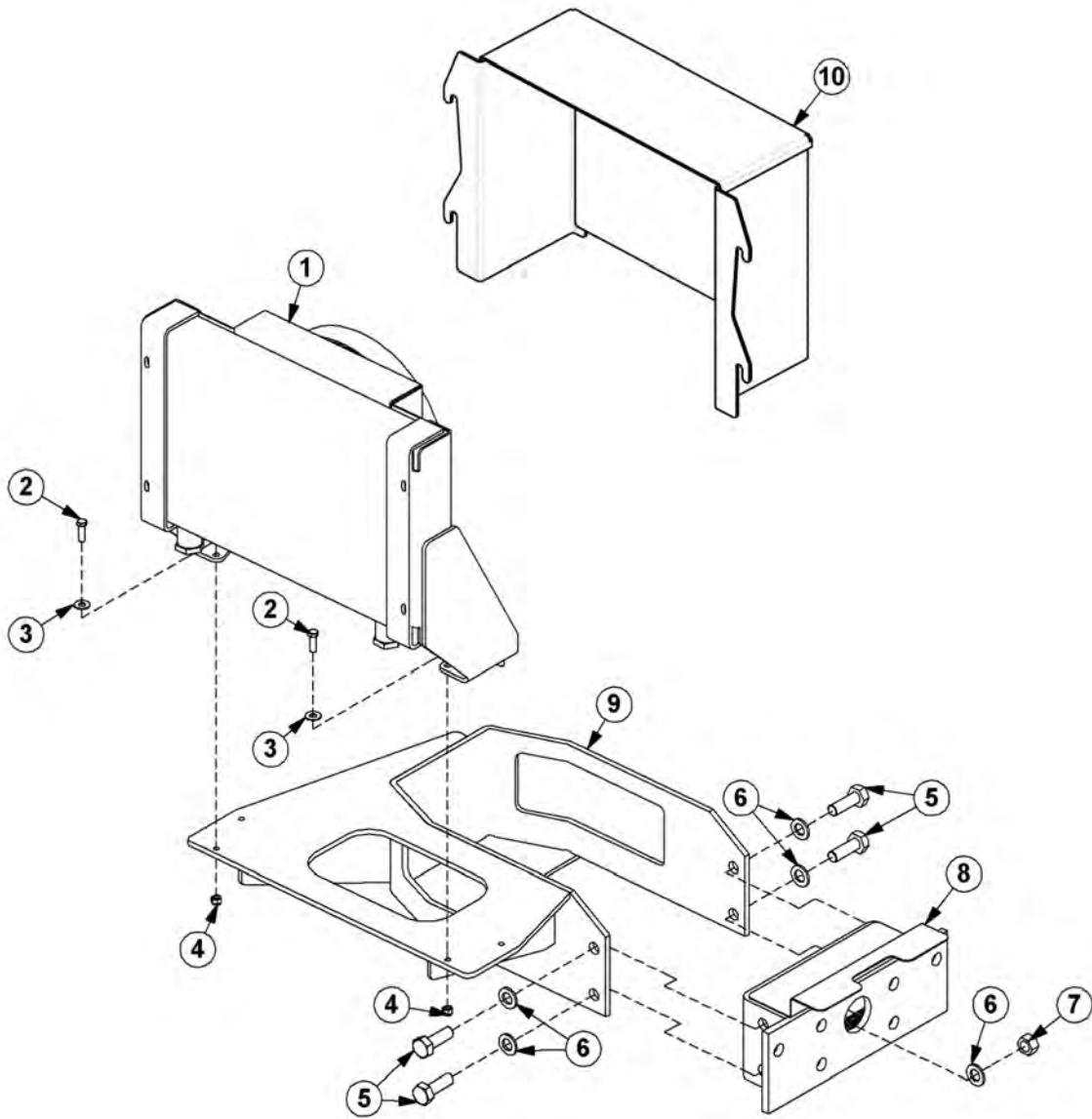

COOLER MOUNT

Continued...

| ITEM | PART NO. | QTY. | DESCRIPTION |
|------|----------|------|---|
| 1 | 06510350 | 1 | COOLER,ELEC TERM,ASSY |
| 2 | 21631 | 2 | CAPSCREW,3/8"X1 1/4", NC,GR8 |
| 3 | 22016 | 2 | FLATWASHER,3/8",GR8 |
| 4 | 21627 | 2 | NYLOCK NUT,3/8" NC |
| 5 | 21833 | 4 | CAPSCREW,3/4" X 2-1/4" NC |
| 6 | 33880 | 8 | FLATWASHER,3/4",GR 8,SAE |
| 7 | 21825 | 4 | HEX NUT,3/4" NC |
| 8 | ----- | - | PUMP MTG BRKT* REFER TO TRACTOR MOUNT KIT |
| 9 | 06380072 | 1 | MNT,CLR,FRNT,UNI |
| 10 | 06370060 | 1 | SCREEN, COOLER, REAR |

TILT CYLINDER

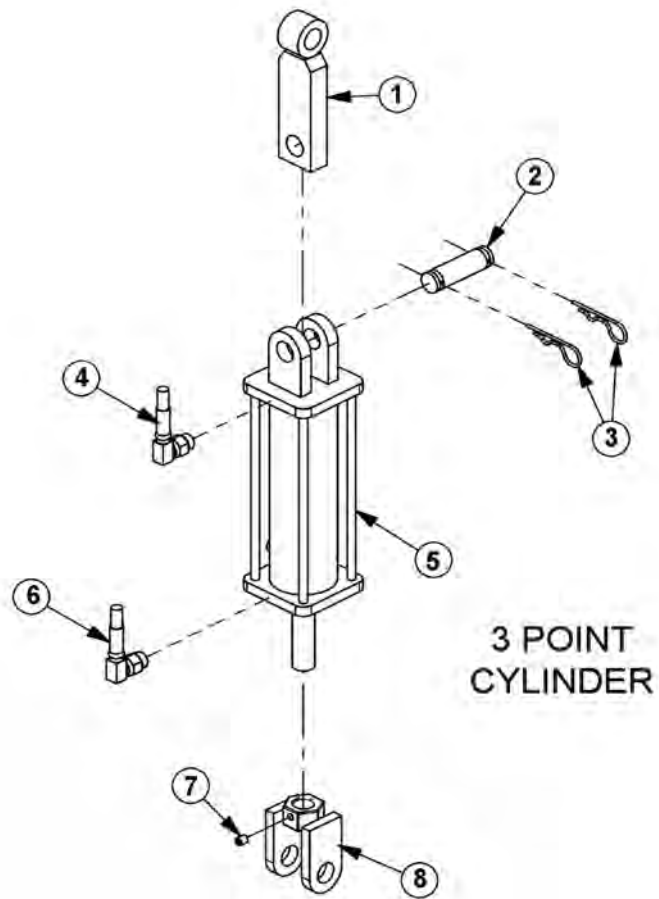

| ITEM | PART NO. | QTY. | DESCRIPTION |
|------|----------|------|------------------------------------|
| 1 | 06370055 | 1 | CLEVIS, CASE MXM, UPPER |
| 2 | TB1033 | 1 | PIN |
| 3 | 6T3004 | 2 | R-CLIP |
| 4 | 34634 | 1 | HOSE, 1/4" X 66" |
| 5 | 30481 | 1 | CYLINDER, 3" X 8" |
| 6 | 34633 | 1 | HOSE, 1/4" X 66" |
| 7 | 6T2272 | 1 | SETSCREW, 3/8" X 1/2" NC |
| 8 | 27519 | 1 | CLEVIS, 3PT, CASE MAXXUM, TRR, LWR |

ZERO SPOOL VALVE OPTION

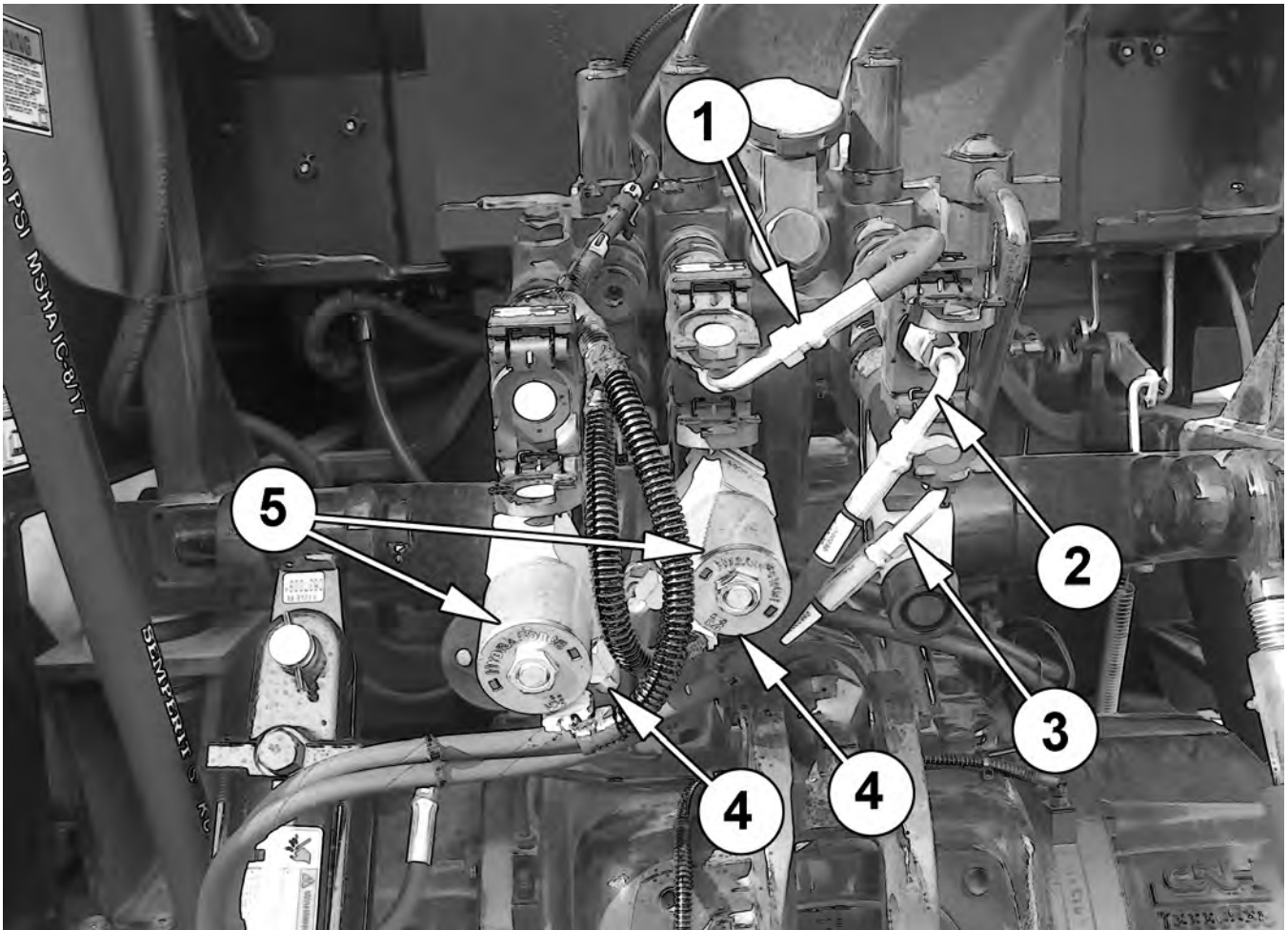

| ITEM | PART NO. | QTY. | DESCRIPTION |
|------|----------|------|---------------------------------|
| 1 | 06500300 | 1 | HOSE, 1/4" X 148" |
| 2 | 06500030 | 1 | HOSE, 1/4" X 28" |
| 3 | 06500029 | 1 | HOSE, 1/4" X 31" |
| 4 | 34631 | 2 | HOSE, 1/4" X 126" |
| 5 | 06510050 | 2 | TRAVEL LOCK, METRIPACK |
| 6 | 32900 | 5 | QUICK COUPLER, MALE (NOT SHOWN) |

NOTES

NOTES

COMMON TWIN ROTARY

PARTS SECTION

NOTES



PART NAME INDEX

| | |
|---|----|
| PARTS ORDERING GUIDE..... | 5 |
| CABLE DRAFT BEAM ASSEMBLY..... | 6 |
| COMBO DRAFT BEAM ASSEMBLY..... | 8 |
| 60IN SIDE CABLE TM ROTARY MOWER..... | 10 |
| 72IN SIDE CABLE TM ROTARY MOWER..... | 12 |
| 60IN SIDE COMBO TM ROTARY MOWER..... | 14 |
| 72IN SIDE COMBO TM ROTARY MOWER..... | 16 |
| 60IN SIDE TSR ROTARY MOWER..... | 18 |
| 60IN REAR TM ROTARY MOWER..... | 20 |
| 60IN REAR TSR ROTARY MOWER..... | 22 |
| REAR ROTARY HYDRAULICS..... | 24 |
| 60IN SIDE TM CHAIN GUARDS..... | 26 |
| 72IN SIDE TM CHAIN GUARDS..... | 28 |
| 60IN TSR REAR GUARDS..... | 30 |
| TM MOWER SPINDLE ASSEMBLY..... | 32 |
| TSR MOWER SPINDLE ASSEMBLY..... | 34 |
| ROTARY DISK AND KNIVES..... | 36 |
| NOTES..... | 37 |
| SIDE ROTARY CASTER WHEEL ASSEMBLY..... | 38 |
| 60IN TM REAR CASTER WHEEL & 3PT ASSY..... | 40 |
| CASTER WHEEL ASSEMBLY..... | 42 |
| SAFETY STAND..... | 43 |
| 3IN X 10IN HYDRAULIC CYLINDER BREAKDOWN..... | 44 |
| 3IN X 12IN HYDRAULIC CYLINDER BREAKDOWN..... | 45 |
| 3IN X 18IN HYDRAULIC CYLINDER BREAKDOWN..... | 46 |
| RESERVOIR TANK FILTER ASSEMBLY..... | 47 |
| ROTARY MOTOR BREAKDOWN..... | 48 |
| 60IN TSR ROTARY MOTOR BREAKDOWN..... | 50 |
| FRONT HYDRAULIC PUMP BREAKDOWN..... | 52 |
| COOLER ASSEMBLY..... | 54 |
| CABLE (MANUAL) LIFT VALVE BREAKDOWN - 31320..... | 56 |
| CABLE (MANUAL) LIFT VALVE BREAKDOWN - 31321..... | 58 |
| CABLE (MANUAL) LIFT VALVE BREAKDOWN - 06502043..... | 60 |
| CABLE (MANUAL) LIFT VALVE BREAKDOWN - 06502044..... | 62 |
| CABLE (MANUAL) LIFT VALVE BREAKDOWN - 06502087..... | 64 |
| CABLE (MANUAL) LIFT VALVE BREAKDOWN - 06502088..... | 66 |
| BRAKE VALVE ASSEMBLY..... | 68 |
| BRAKE VALVE HYDRAULIC SCHEMATIC..... | 69 |
| CABLE DRAFT BEAM TRAVEL LOCK..... | 70 |
| COMBO DRAFT BEAM TRAVEL LOCK..... | 71 |

COMMON TWIN

PART NAME INDEX

| | |
|---------------------------|----|
| SWITCH BOX..... | 72 |
| SWITCH BOX SCHEMATIC..... | 73 |
| NOTES 1..... | 74 |

PARTS ORDERING GUIDE

The following instructions are offered to help eliminate needless delay and error in processing purchase orders for the equipment in this manual.

1. The Parts Section is prepared in logical sequence and grouping of parts that belong to the basic machine featured in this manual. Part Numbers and Descriptions are given to help locate the parts and quantities required.
2. The Purchase Order must indicate the **Name and Address** of the person or organization ordering the parts, **who should be charged**, and if possible, the **serial number of the machine** for which the parts are being ordered.
3. The purchase order must clearly list the **quantity of each part**, the complete and correct **part number**, and the basic **name of the part**.
4. The manufacturer reserves the right to substitute parts where applicable.
5. Some parts may be unlisted items which are special production items not normally stocked and are subject to special handling. Request a quotation for such parts before sending a purchase order.
6. The manufacturer reserves the right to change prices without prior notice.

NOTE: When ordering replacement decals, refer to the part numbers and descriptions listed in the safety section in the front of this manual.

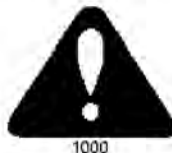

For maximum safety and to guarantee optimum product reliability, always use genuine **Tiger** replacement parts. The use of inferior replacement parts may cause premature or catastrophic failure which could result in serious injury or death.

Direct any questions regarding parts to:

Tiger Corporation
3301 N. Louise Ave.
Sioux Falls, SD 57107
1-800-843-6849
1-605-336-7900

CABLE DRAFT BEAM ASSEMBLY

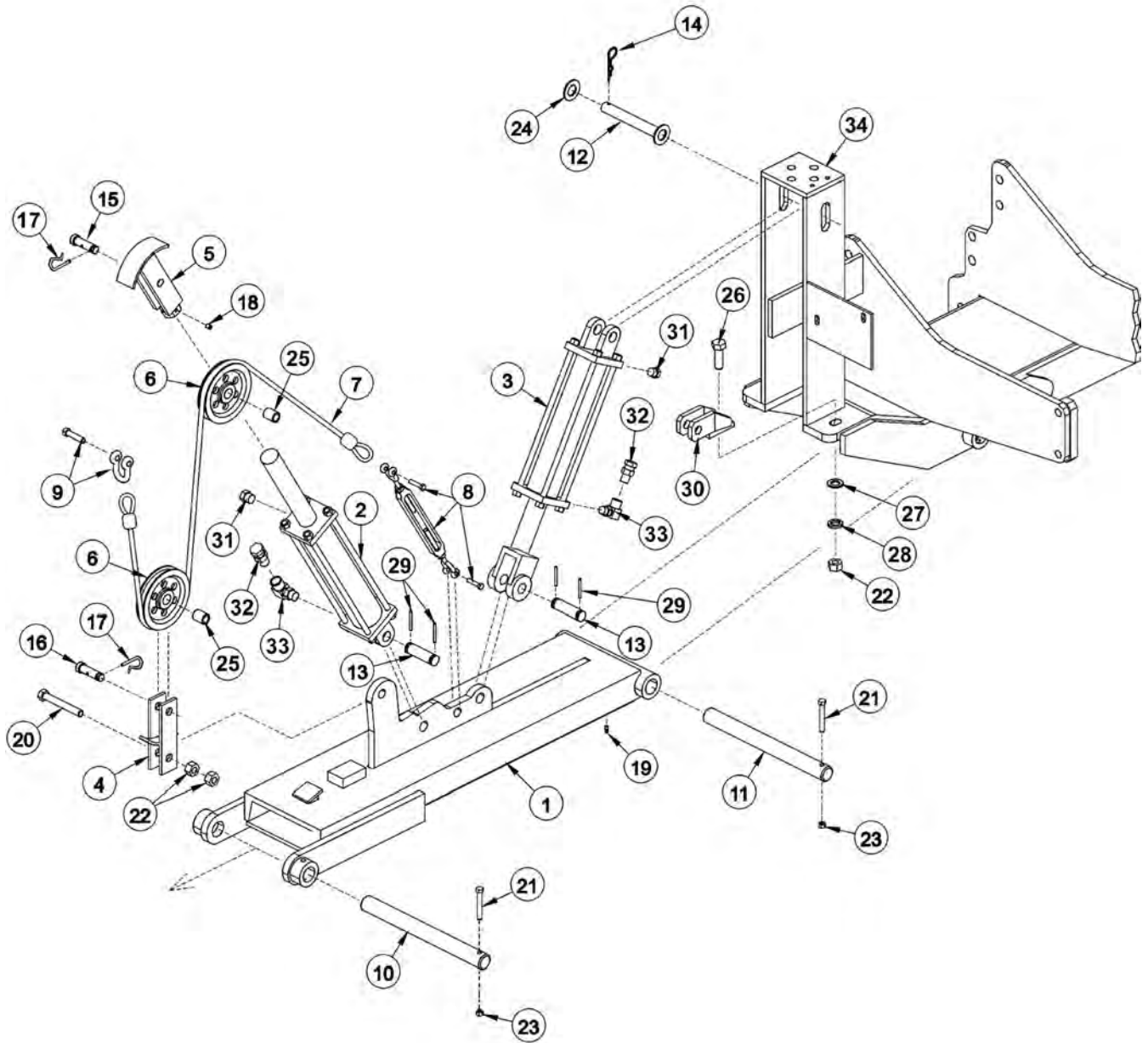

CABLE DRAFT BEAM ASSEMBLY

Continued...

| ITEM | PART NO. | QTY. | DESCRIPTION |
|------|----------|------|--|
| 1 | 6T0105 | - | DRAFT BEAM (STD WITH TRAVEL LOCK) |
| --- | 27241 | - | DRAFT BEAM (EXTENDED 6") |
| 2 | 6T0150 | 1 | CYLINDER 3" X 18" |
| 3 | 6T0151R | 1 | HYD. CYLINDER 3" X 10" |
| 4 | 6T0100 | 1 | LOWER SHEAVE BRACKET |
| 5 | 6T0101 | 1 | UPPER SHEAVE BRACKET |
| 6 | 33768 | 2 | SHEAVE |
| 7 | 6T0110 | 1 | LIFT CABLE (STD 1/2" X 87 1/2") |
| --- | 6T0110E | - | LIFT CABLE (EXTENDED 6") |
| 8 | 6T0115 | 1 | TURN BUCKLE |
| 9 | 6T0112 | 1 | SHACKLE WITH PIN |
| 10 | 6T2999 | 1 | OUTER DRAFT BEAM PIN 1 1/2" X 14 1/2" |
| 11 | 6T3001 | 1 | INNER DRAFT BEAM PIN 1 1/2" X 15 3/4" |
| 12 | 6T3005 | 1 | CYLINDER PIN 1" X 6 5/8" |
| 13 | TB1033 | 2 | CLEVIS PIN 1" X 4" |
| 14 | 6T3004 | 1 | R - CLIP 3/16" |
| 15 | 6T3010 | 1 | UPPER SHEAVE PIN WITH ZERK 3/4" X 3" |
| 16 | 6T3009 | 1 | LOWER SHEAVE PIN WITH ZERK 3/4" X 2 1/2" |
| 17 | 6T3020 | 2 | R - CLIP 5/32" |
| 18 | 6T2272 | 1 | SET SCREW 3/8" X 1/2" |
| 19 | 6T3211 | 1 | GREASE ZERK 1/8" STRAIGHT |
| 20 | 21837 | 1 | CAPSCREW 3/4" X 3 1/4" |
| 21 | 21688 | 2 | CAPSCREW 7/16" X 3 1/4" |
| 22 | 21825 | 2 | HEX NUT 3/4" |
| 23 | 21677 | 2 | NYLOCK NUT 7/16" |
| 24 | 22023 | 1 | FLAT WASHER 1" |
| 25 | 6T0104N | 2 | SHEAVE PIN BUSHING 1" OD X 3/4" ID |
| 26 | 21833 | 1 | CAPSCREW 3/4" X 2 1/4" |
| 27 | 22021 | 1 | FLAT WASHER 3/4" |
| 28 | 21993 | 1 | LOCK WASHER 3/4" |
| 29 | 06537021 | 4 | ROLL PIN |
| 30 | 6T0106 | 1 | TRAVEL LOCK BRACKET |
| 31 | 6T4258 | 2 | BREATHER 1/2" |
| 32 | 34396 | 2 | RESTRICTOR |
| 33 | 34244 | 2 | ELBOW FITTING 1/2" |
| 34 | ----- | - | MAIN FRAME *REFER TO TRACTOR PARTS SECTION |

COMMON TWIN

COMBO DRAFT BEAM ASSEMBLY

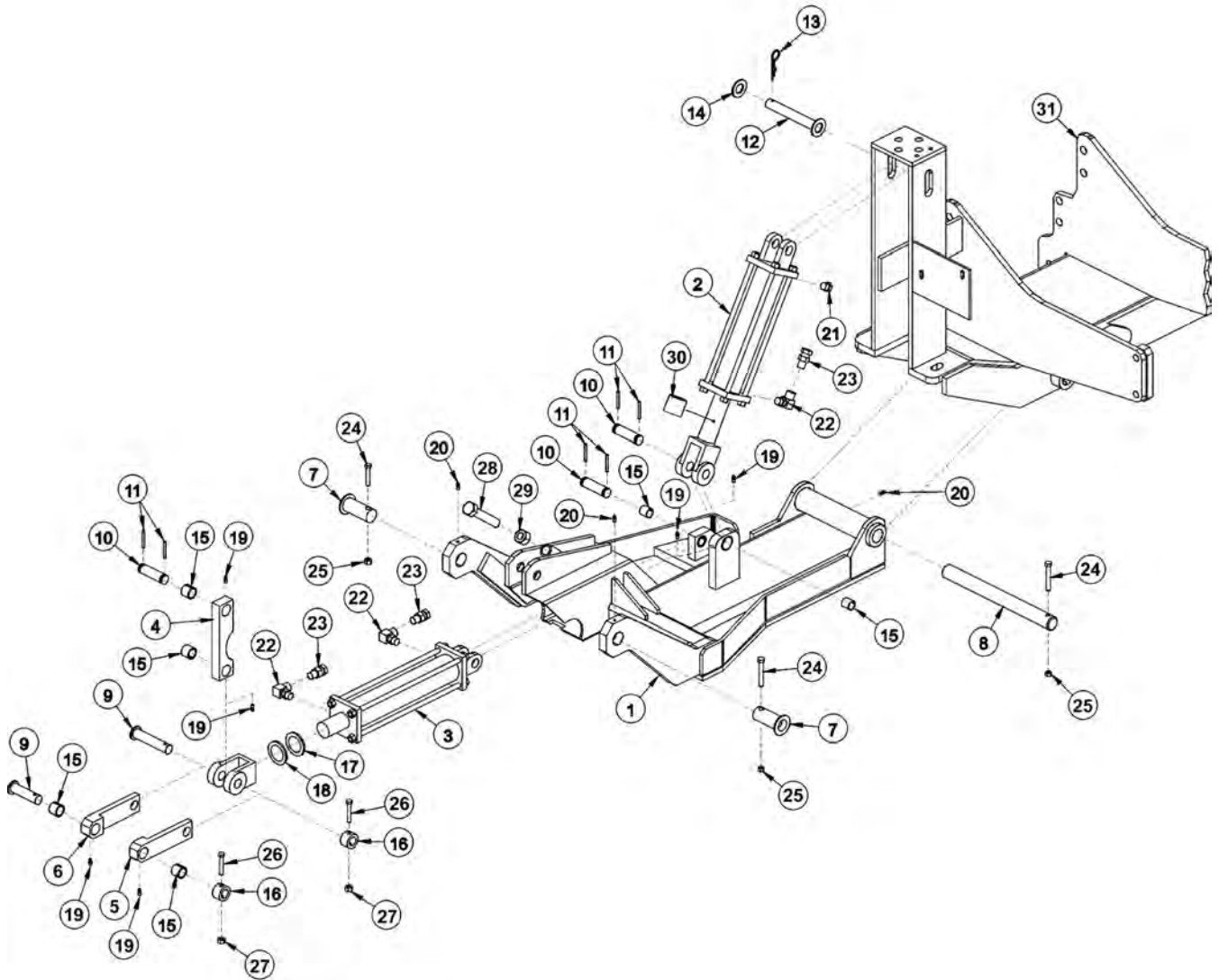

NOTES:

1. ITEM 30 IS USED ON THE GLAND END OF ITEM 2 (AS NEEDED)
2. ORIENTATION OF ITEMS 4,5 & 6 ARE CRITICAL

COMBO DRAFT BEAM ASSEMBLY

Continued...

| ITEM | PART NO. | QTY. | DESCRIPTION |
|------|----------|------|---|
| 1 | 06350001 | 1 | COMBO DRAFT BEAM - STD DTY ROTARY |
| --- | 31063 | - | COMBO DRAFT BEAM - HVY DTY ROTARY |
| 2 | 6T0151R | 1 | HYD. CYLINDER 3" X 10" |
| 3 | 32215 | 1 | HYD. CYLINDER 3" X 12" - STD DTY |
| --- | 25343 | - | HYD. CYLINDER 3" X 12" - HVY DTY |
| 4 | TF4500A | 1 | PIVOT ARM |
| 5 | TF4507B | 1 | RIGHT LINKAGE ARM |
| 6 | TF4506B | 1 | LEFT LINKAGE ARM |
| 7 | 30126B | 2 | PIN, HEAD PIVOT - STD DTY |
| --- | TF4514A | - | PIN, HEAD PIVOT - HVY DTY |
| 8 | 6T3001 | 1 | PIN, BEAM PIVOT |
| 9 | TF4519 | 2 | PIN, LINKAGE |
| 10 | TB1033 | 3 | PIN, CLEVIS |
| 11 | 06537021 | 6 | ROLLPIN |
| 12 | 6T3005 | 1 | PIN, 1" W/ CAP |
| 13 | 6T3004 | 1 | R-CLIP HAIRPIN |
| 14 | 6T2614 | 1 | FLATWASHER 1" |
| 15 | TB3010 | 8 | BUSHING 1" |
| 16 | 22847 | 2 | BOSS, LINKAGE PIN |
| 17 | 22076 | 1 | SPACER, HYD. CYLINDER 1/4" |
| 18 | 22077 | 1 | SPACER, HYD. CYLINDER 5/16" |
| 19 | 6T3207 | 6 | GREASE ZERK 1/4" |
| 20 | 6T3211 | 3 | GREASE ZERK 1/8" |
| 21 | 6T4258 | 1 | BREATHER 1/2" |
| 22 | 34244 | 3 | ELBOW FITTING 1/2" |
| 23 | 34396 | 3 | SWIVEL RESTRICTOR |
| 24 | 21688 | 3 | CAPSCREW 7/16" X 3 1/4" |
| 25 | 21677 | 3 | NYLOCK NUT 7/16" |
| 26 | 21635 | 2 | CAPSCREW 3/8" X 2 1/4" |
| 27 | 21625 | 2 | HEX NUT 3/8" |
| 28 | 21831 | 1 | CAPSCREW 3/4" X 1 3/4" |
| 29 | 21825 | 1 | HEX NUT 3/4" |
| 30 | 06700095 | 1 | CYLINDER SPACER W/SET SCREW |
| 31 | ----- | - | MAIN FRAME *REFER TO TRACTOR MOUNT PAGE |

COMMON TWIN

60IN SIDE CABLE TM ROTARY MOWER

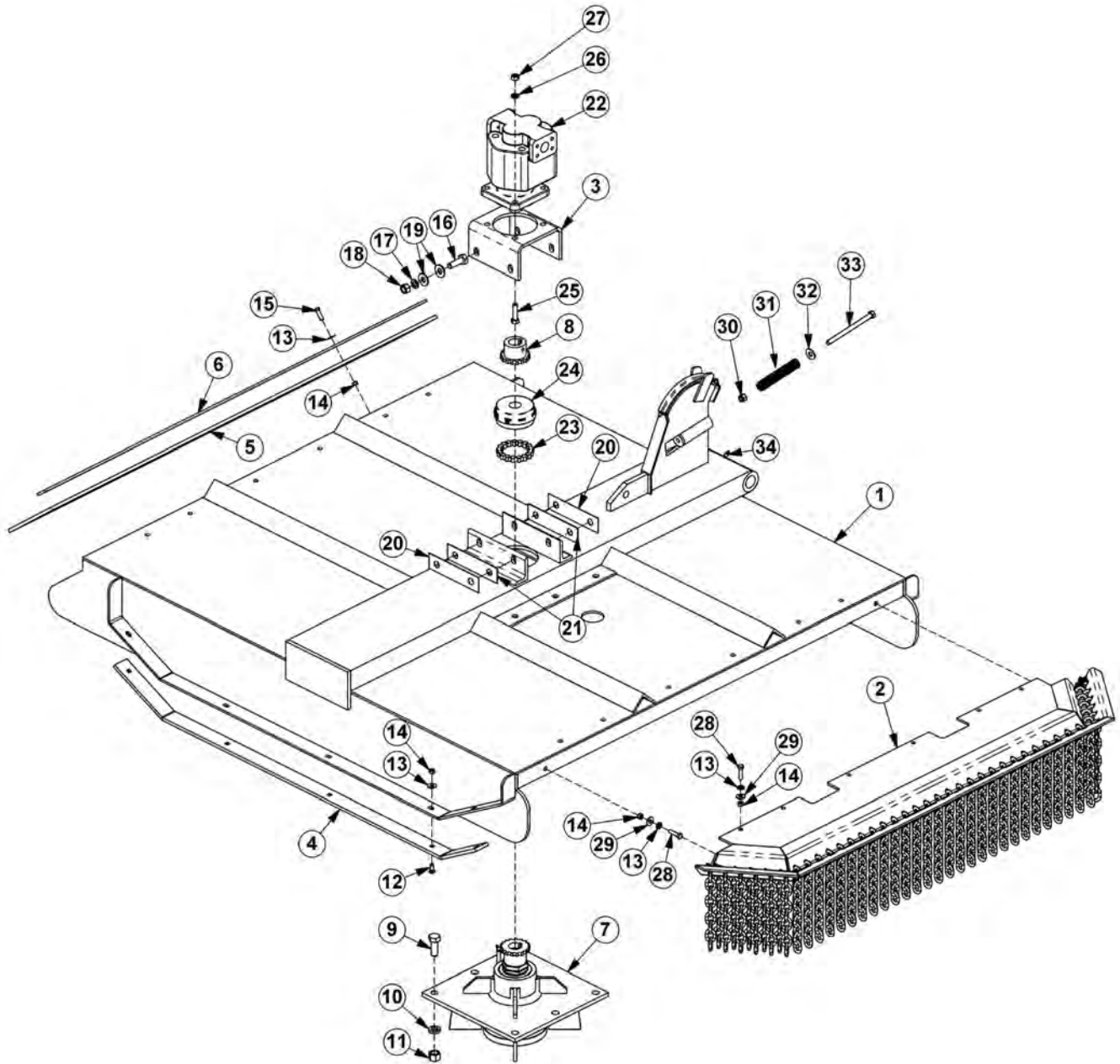

COMMON TWIN

60IN SIDE CABLE TM ROTARY MOWER

Continued...

| ITEM | PART NO. | QTY. | DESCRIPTION |
|------|----------|------|---------------------------------------|
| 1 | 32099 | 1 | RTRY, 60" DECK, CABLE |
| 2 | 31773 | 1 | GAURD,CHAIN,FRONT,SR60 |
| 3 | 6T1001 | 1 | BRKT, MOTOR MTG, 60"SIDE RTRY |
| 4 | 6T0820H | 2 | SKID SHOE, TM60 |
| 5 | 22592 | 1 | FLAP, DEFLECTOR, TM60 |
| 6 | 6T0823 | 1 | BAR, FLAP, TM60 |
| 7 | 6T1024H5 | 1 | SPINDLE ASSY,CPLT,HD,5/8" HOLES |
| 8 | 21223 | 1 | SPROCKET, 1-1/4" BORE |
| 9 | 6T2277 | 6 | CAPSCREW,3/4" X 2",NF |
| 10 | 21993 | 6 | LOCKWASHER,3/4",GR 8 |
| 11 | 6T2413 | 6 | HEX NUT,3/4",NF,GR 8 |
| 12 | 6T2270 | 10 | PLOW BOLT,3/8" X 1",NC |
| 13 | 22016 | 29 | FLATWASHER,3/8" |
| 14 | 21625 | 29 | HEX NUT,3/8",NC |
| 15 | 21631 | 11 | CAPSCREW, 3/8" X 1-1/4",NC |
| 16 | 21783 | 4 | CAPSCREW, 5/8" X 2",NC |
| 17 | 21992 | 4 | LOCKWASHER, 5/8" |
| 18 | 21775 | 4 | HEX NUT, 5/8" |
| 19 | 25270 | 8 | FLATWASHER,5/8",GR 8 |
| 20 | 6T0822 | 2 | SHIM, MOTOR MOUNT, 14GA. (AS NEEDED) |
| 21 | 6T0822A | 2 | SHIM, MOTOR MOUNT, 18 GA. (AS NEEDED) |
| 22 | 6504011 | 1 | MOTOR,(M365-2 1/4" GEAR) |
| 23 | 6T1029 | 1 | CHAIN, COUPLING |
| 24 | 6T1033 | 1 | COVER, COUPLING |
| 25 | 21733 | 4 | CAPSCREW, 1/2" X 2",NC |
| 26 | 21990 | 4 | LOCKWASHER,1/2" |
| 27 | 21725 | 4 | HEX NUT, 1/2",NC |
| 28 | 21632 | 8 | CAPSCREW,3/8" X 1-1/2",NC |
| 29 | 21988 | 8 | LOCKWASHER,3/8" |
| 30 | 21727 | 1 | NYLOCK NUT,1/2",NC |
| 31 | 27005 | 1 | SPRING,PUSHOFF,SIDE RTRY |
| 32 | 22018 | 1 | FLATWASHER,1/2",WIDE |
| 33 | 21745 | 1 | CAPSCREW,1/2" X 7",NC |
| 34 | 6T3211 | 1 | GREASE ZERK |

COMMON TWIN

72IN SIDE CABLE TM ROTARY MOWER

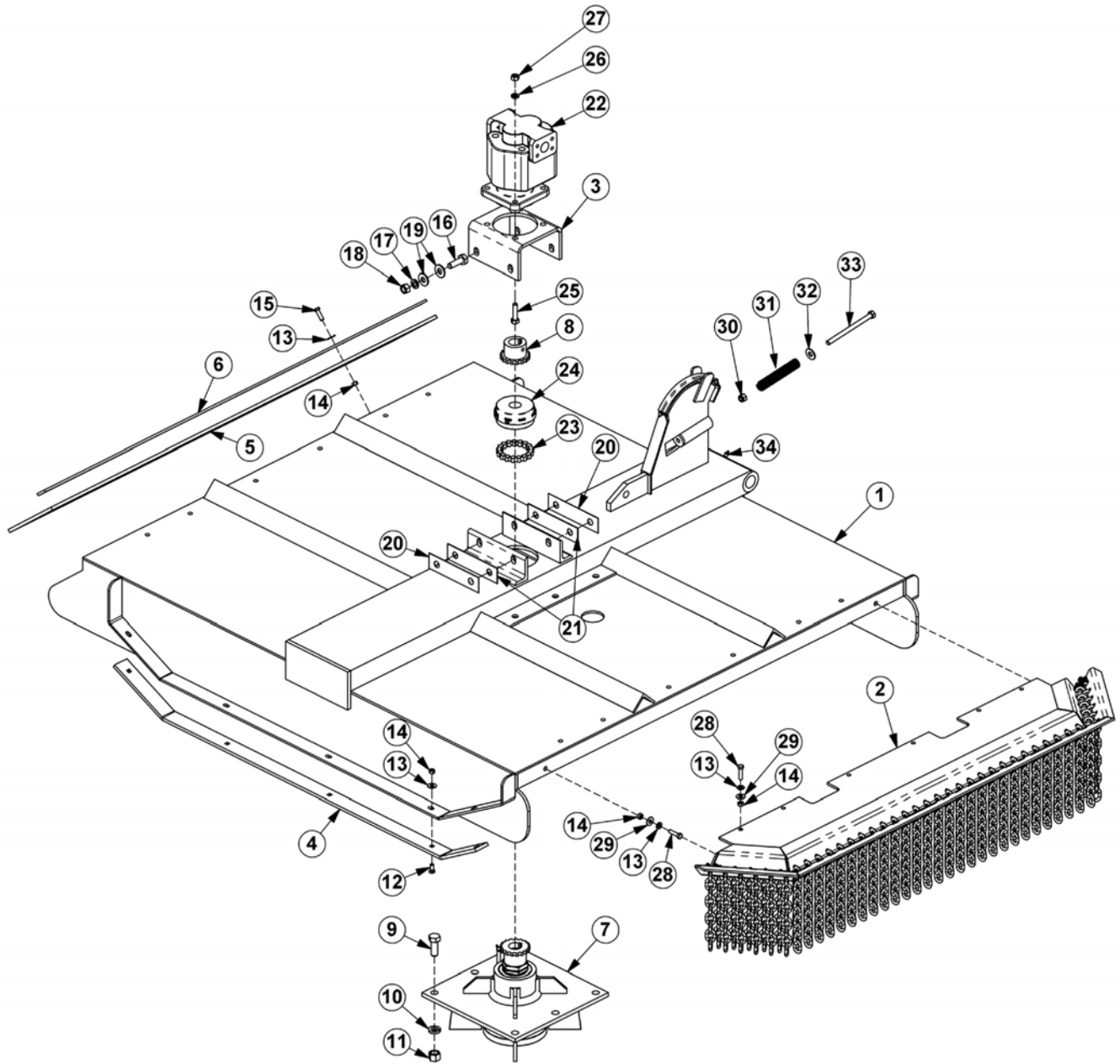

COMMON TWIN

72IN SIDE CABLE TM ROTARY MOWER

Continued...

| ITEM | PART NO. | QTY. | DESCRIPTION |
|------|----------|------|---------------------------------------|
| 1 | 21225B | 1 | RTRY,72" DECK, CABLE |
| 2 | 31931 | 1 | GUARD,CHAIN,FRONT,SR72 |
| 3 | 6T1001 | 1 | BRKT, MOTOR MTG, 60"SIDE RTRY |
| 4 | 21248 | 2 | SKID SHOE, TM72 |
| 5 | 21295B | 1 | FLAP, DEFLECTOR, TM72 |
| 6 | 21242A | 1 | BAR, FLAP, TM72 |
| 7 | 6T1024H5 | 1 | SPINDLE ASSY,CPLT,HD,5/8" HOLES |
| 8 | 21223 | 1 | SPROCKET, 1-1/4" BORE |
| 9 | 6T2277 | 6 | CAPSCREW,3/4" X 2",NF |
| 10 | 21993 | 6 | LOCKWASHER,3/4",GR 8 |
| 11 | 6T2413 | 6 | HEX NUT,3/4",NF,GR 8 |
| 12 | 6T2270 | 10 | PLOW BOLT,3/8" X 1",NC |
| 13 | 22016 | 29 | FLATWASHER,3/8" |
| 14 | 21625 | 29 | HEX NUT,3/8",NC |
| 15 | 21631 | 11 | CAPSCREW, 3/8" X 1-1/4",NC |
| 16 | 21783 | 4 | CAPSCREW, 5/8" X 2",NC |
| 17 | 21992 | 4 | LOCKWASHER, 5/8" |
| 18 | 21775 | 4 | HEX NUT, 5/8" |
| 19 | 25270 | 8 | FLATWASHER,5/8",GR 8 |
| 20 | 6T0822 | 2 | SHIM, MOTOR MOUNT, 14GA. (AS NEEDED) |
| 21 | 6T0822A | 2 | SHIM, MOTOR MOUNT, 18 GA. (AS NEEDED) |
| 22 | 06504011 | 1 | MOTOR,(M365-2 1/4" GEAR) |
| 23 | 6T1029 | 1 | CHAIN, COUPLING |
| 24 | 6T1033 | 1 | COVER, COUPLING |
| 25 | 21733 | 4 | CAPSCREW, 1/2" X 2",NC |
| 26 | 21990 | 4 | LOCKWASHER,1/2" |
| 27 | 21725 | 4 | HEX NUT, 1/2",NC |
| 28 | 21632 | 8 | CAPSCREW,3/8" X 1-1/2",NC |
| 29 | 21988 | 8 | LOCKWASHER,3/8" |
| 30 | 21727 | 1 | NYLOCK NUT,1/2",NC |
| 31 | 27005 | 1 | SPRING,PUSHOFF,SIDE RTRY |
| 32 | 22018 | 1 | FLATWASHER,1/2",WIDE |
| 33 | 21745 | 1 | CAPSCREW,1/2" X 7",NC |
| 34 | 6T3211 | 1 | GREASE ZERK |

COMMON TWIN

60IN SIDE COMBO TM ROTARY MOWER

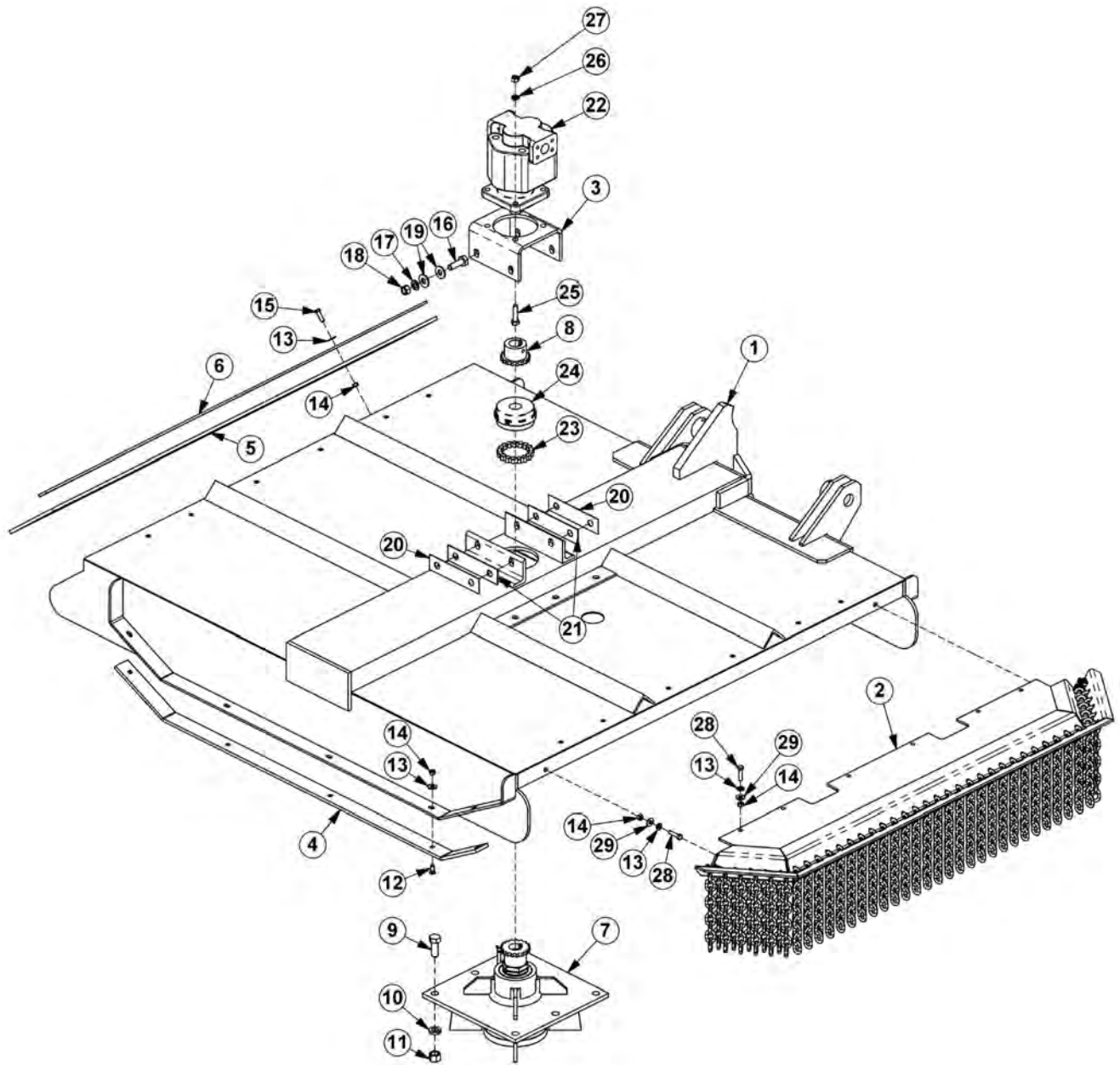

COMMON TWIN

60IN SIDE COMBO TM ROTARY MOWER

Continued...

| ITEM | PART NO. | QTY. | DESCRIPTION |
|------|----------|------|---------------------------------------|
| 1 | 30087D | 1 | RTRY, 60" DECK, COMBO - STD DUTY |
| --- | 32617 | 1 | RTRY, 60" DECK, COMBO - HVY DUTY |
| 2 | 31773 | 1 | GAURD,CHAIN,FRONT,SR60 |
| 3 | 6T1001 | 1 | BRKT, MOTOR MTG, 60"SIDE RTRY |
| 4 | 6T0820H | 2 | SKID SHOE, TM60 |
| 5 | 22592 | 1 | FLAP, DEFLECTOR, TM60 |
| 6 | 6T0823 | 1 | BAR, FLAP, TM60 |
| 7 | 6T1024H5 | 1 | SPINDLE ASSY,CPLT,HD,5/8" HOLES |
| 8 | 21223 | 1 | SPROCKET, 1-1/4" BORE |
| 9 | 6T2277 | 6 | CAPSCREW,3/4" X 2",NF |
| 10 | 21993 | 6 | LOCKWASHER,3/4",GR 8 |
| 11 | 6T2413 | 6 | HEX NUT,3/4",NF,GR 8 |
| 12 | 6T2270 | 10 | PLOW BOLT,3/8" X 1",NC |
| 13 | 22016 | 29 | FLATWASHER,3/8" |
| 14 | 21625 | 29 | HEX NUT,3/8",NC |
| 15 | 21631 | 11 | CAPSCREW, 3/8" X 1-1/4",NC |
| 16 | 21783 | 4 | CAPSCREW, 5/8" X 2",NC |
| 17 | 21992 | 4 | LOCKWASHER, 5/8" |
| 18 | 21775 | 4 | HEX NUT, 5/8" |
| 19 | 25270 | 8 | FLATWASHER,5/8",GR 8 |
| 20 | 6T0822 | 2 | SHIM, MOTOR MOUNT, 14GA. (AS NEEDED) |
| 21 | 6T0822A | 2 | SHIM, MOTOR MOUNT, 18 GA. (AS NEEDED) |
| 22 | 06504011 | 1 | MOTOR,(M365-2 1/4" GEAR) |
| 23 | 6T1029 | 1 | CHAIN, COUPLING |
| 24 | 6T1033 | 1 | COVER, COUPLING |
| 25 | 21733 | 4 | CAPSCREW, 1/2" X 2",NC |
| 26 | 21990 | 4 | LOCKWASHER,1/2" |
| 27 | 21725 | 4 | HEX NUT, 1/2",NC |
| 28 | 21632 | 8 | CAPSCREW,3/8" X 1-1/2",NC |
| 29 | 21988 | 8 | LOCKWASHER,3/8" |

COMMON TWIN

72IN SIDE COMBO TM ROTARY MOWER

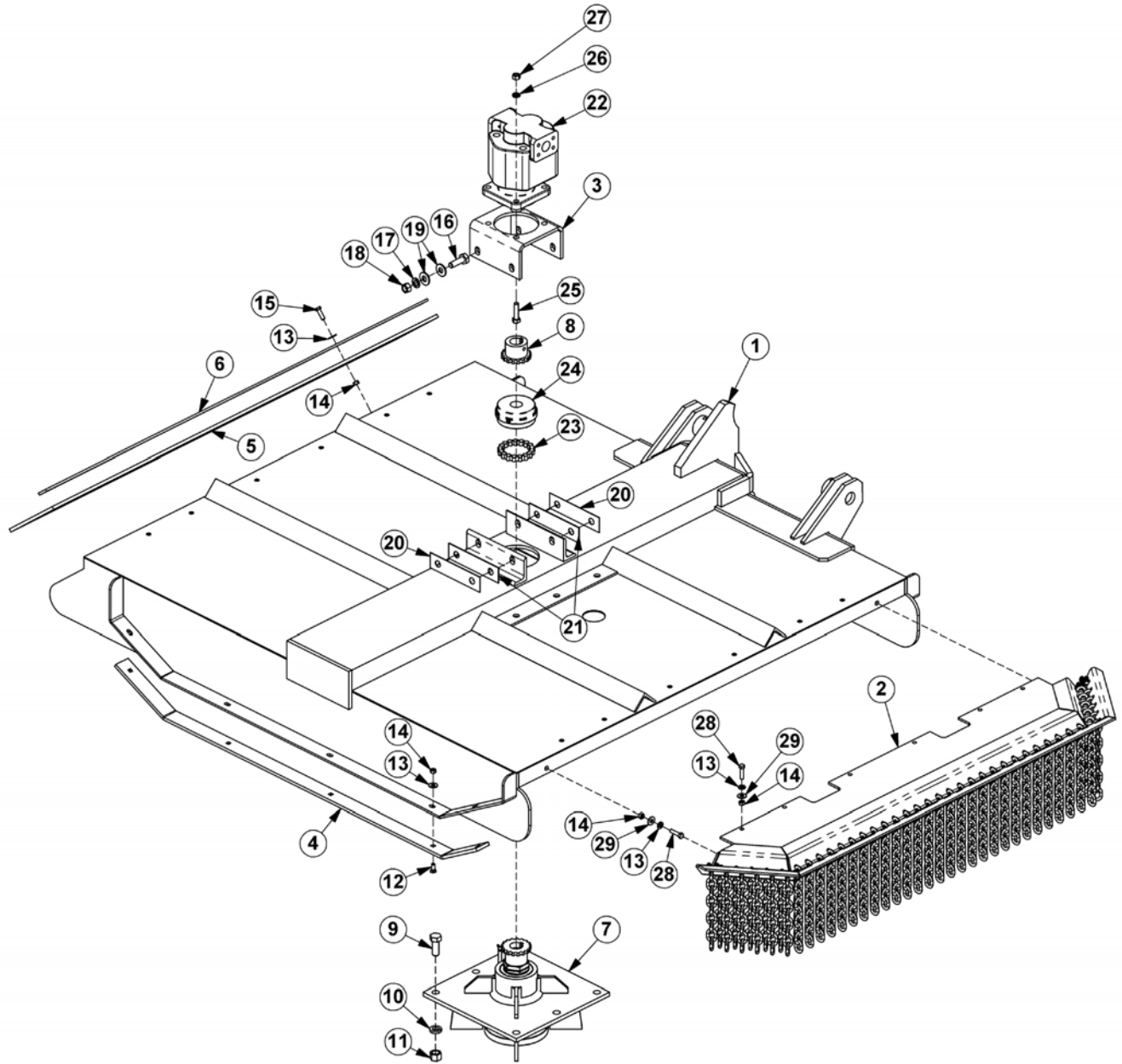

COMMON TWIN

72IN SIDE COMBO TM ROTARY MOWER

Continued...

| ITEM | PART NO. | QTY. | DESCRIPTION |
|------|----------|------|---------------------------------------|
| 1 | 34260 | 1 | RTRY, 72" DECK, COMBO - STD DUTY |
| --- | 31408A | 1 | RTRY, 72" DECK, COMBO - HEAVY DUTY |
| 2 | 31931 | 1 | GUARD,CHAIN,FRONT,SR72 |
| 3 | 6T1001 | 1 | BRKT, MOTOR MTG, 60"SIDE RTRY |
| 4 | 21248 | 2 | SKID SHOE, TM72 |
| 5 | 21295B | 1 | FLAP, DEFLECTOR, TM72 |
| 6 | 21242A | 1 | BAR, FLAP, TM72 |
| 7 | 6T1024H5 | 1 | SPINDLE ASSY,CPLT,HD,5/8" HOLES |
| 8 | 21223 | 1 | SPROCKET, 1-1/4" BORE |
| 9 | 6T2277 | 6 | CAPSCREW,3/4" X 2",NF |
| 10 | 21993 | 6 | LOCKWASHER,3/4",GR 8 |
| 11 | 6T2413 | 6 | HEX NUT,3/4",NF,GR 8 |
| 12 | 6T2270 | 10 | PLOW BOLT,3/8" X 1",NC |
| 13 | 22016 | 29 | FLATWASHER,3/8" |
| 14 | 21625 | 29 | HEX NUT,3/8",NC |
| 15 | 21631 | 11 | CAPSCREW, 3/8" X 1-1/4",NC |
| 16 | 21783 | 4 | CAPSCREW, 5/8" X 2",NC |
| 17 | 21992 | 4 | LOCKWASHER, 5/8" |
| 18 | 21775 | 4 | HEX NUT, 5/8" |
| 19 | 25270 | 8 | FLATWASHER,5/8",GR 8 |
| 20 | 6T0822 | 2 | SHIM, MOTOR MOUNT, 14GA. (AS NEEDED) |
| 21 | 6T0822A | 2 | SHIM, MOTOR MOUNT, 18 GA. (AS NEEDED) |
| 22 | 06504011 | 1 | MOTOR,(M365-2 1/4" GEAR) |
| 23 | 6T1029 | 1 | CHAIN, COUPLING |
| 24 | 6T1033 | 1 | COVER, COUPLING |
| 25 | 21733 | 4 | CAPSCREW, 1/2" X 2",NC |
| 26 | 21990 | 4 | LOCKWASHER,1/2" |
| 27 | 21725 | 4 | HEX NUT, 1/2",NC |
| 28 | 21632 | 8 | CAPSCREW,3/8" X 1-1/2",NC |
| 29 | 21988 | 8 | LOCKWASHER,3/8" |

COMMON TWIN

60IN SIDE TSR ROTARY MOWER

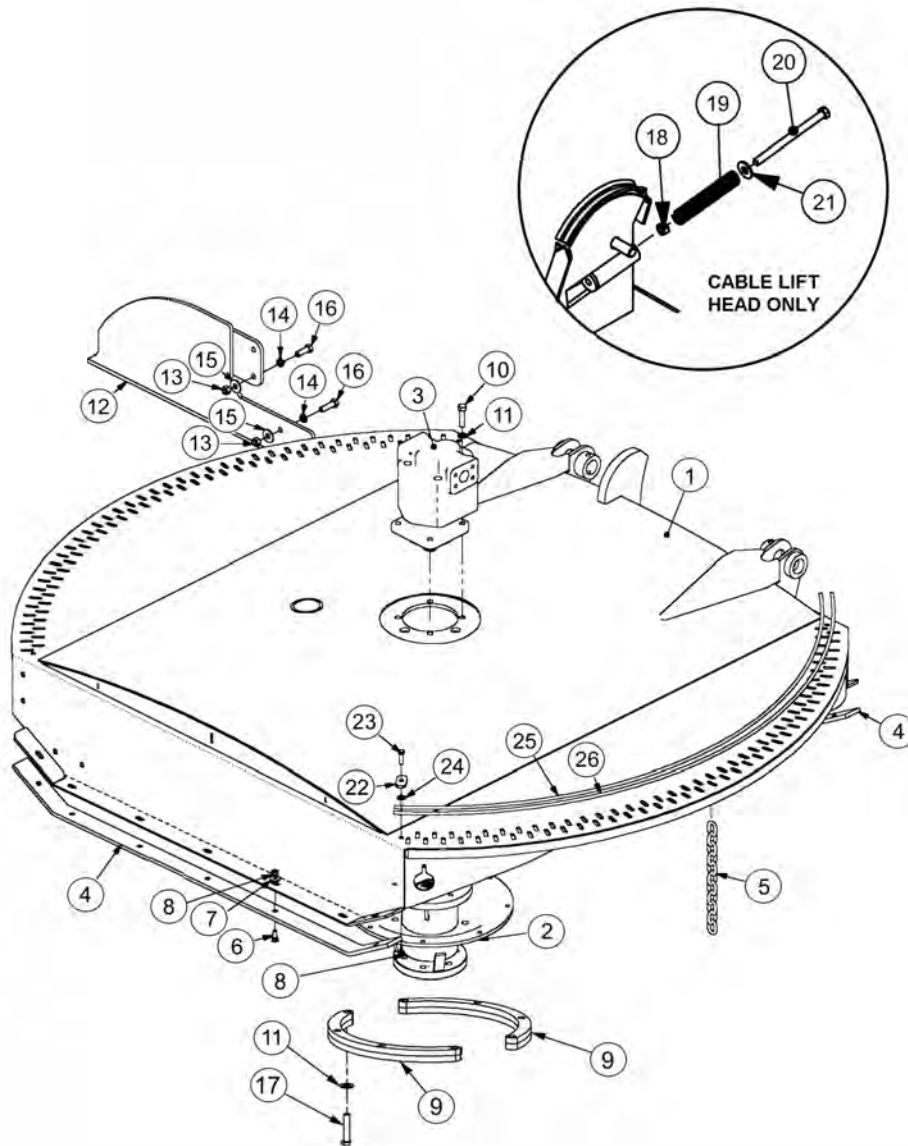

60IN SIDE TSR ROTARY MOWER

Continued...

| ITEM | PART NO. | QTY. | DESCRIPTION |
|------|----------|------|---------------------------------------|
| 1 | 34975 | 1 | HEAVY DUTY GRASSKAT COMBO |
| --- | 06320005 | 1 | STD DUTY GRASSKAT COMBO |
| ---- | 06320008 | 1 | HEAVY DUTY GRASSKAT CABLE |
| 2 | 34980 | 1 | SPINDLE ASSY,TM 60" |
| 3 | 06504016 | 1 | CURRENT MOTOR,(M365-1 1/4" 14-SPLINE) |
| 4 | 06410254 | 2 | SKID,OUTBOARD,TM60 |
| 5 | 22992 | 156 | CHAIN,10 LINK |
| 6 | 6T2270 | 14 | PLOW BOLT,3/8" X 1" NC |
| 7 | 22016 | 26 | FLATWASHER,3/8" |
| 8 | 21625 | 30 | HEX NUT,3/8",NC |
| 9 | 06320011 | 2 | SPACER,TSF,SPINDLE |
| 10 | 6T1025 | 4 | CAPSCREW, 1/2 X 2,GR 8,NC |
| 11 | 06533006 | 4 | FLATWASHER,1/2,SAE,GR 8 |
| 12 | 06370029 | 1 | TIRE GUARD, LEFT |
| 13 | 21725 | 8 | HEX NUT, 1/2",NC |
| 14 | 21990 | 8 | LOCKWASHER, 1/2" |
| 15 | 22018 | 8 | FLATWASHER, 1/2",WIDE |
| 16 | 21731 | 4 | CAPSCREW, 1/2" X 1-1/2" NC |
| 17 | 21732 | 4 | CAPSCREW, 1/2" X 1-3/4" NC |
| 18 | 21745 | 1 | NYLOCK NUT, 1/2 |
| 19 | 21727 | 1 | SPRING, PUSHOFF, SIDE RTRY |
| 20 | 27005 | 1 | CAPSCREW, 1/2 X 7,NC |
| 21 | 22018 | 1 | FLATWASHER,1/2",WIDE |
| 22 | 34972 | 4 | PLATE,CAP,CHAIN |
| 23 | 21631 | 16 | CAPSCREW, 3/8 X 1-1/4,NC |
| 24 | 21988 | 16 | LOCKWASHER, 3/8" |
| 25 | 34974 | 2 | ROD,CHAIN,INNER,TM60 |
| 26 | 34973 | 2 | ROD,CHAIN,OUTER,TM60 |

COMMON TWIN

60IN REAR TM ROTARY MOWER

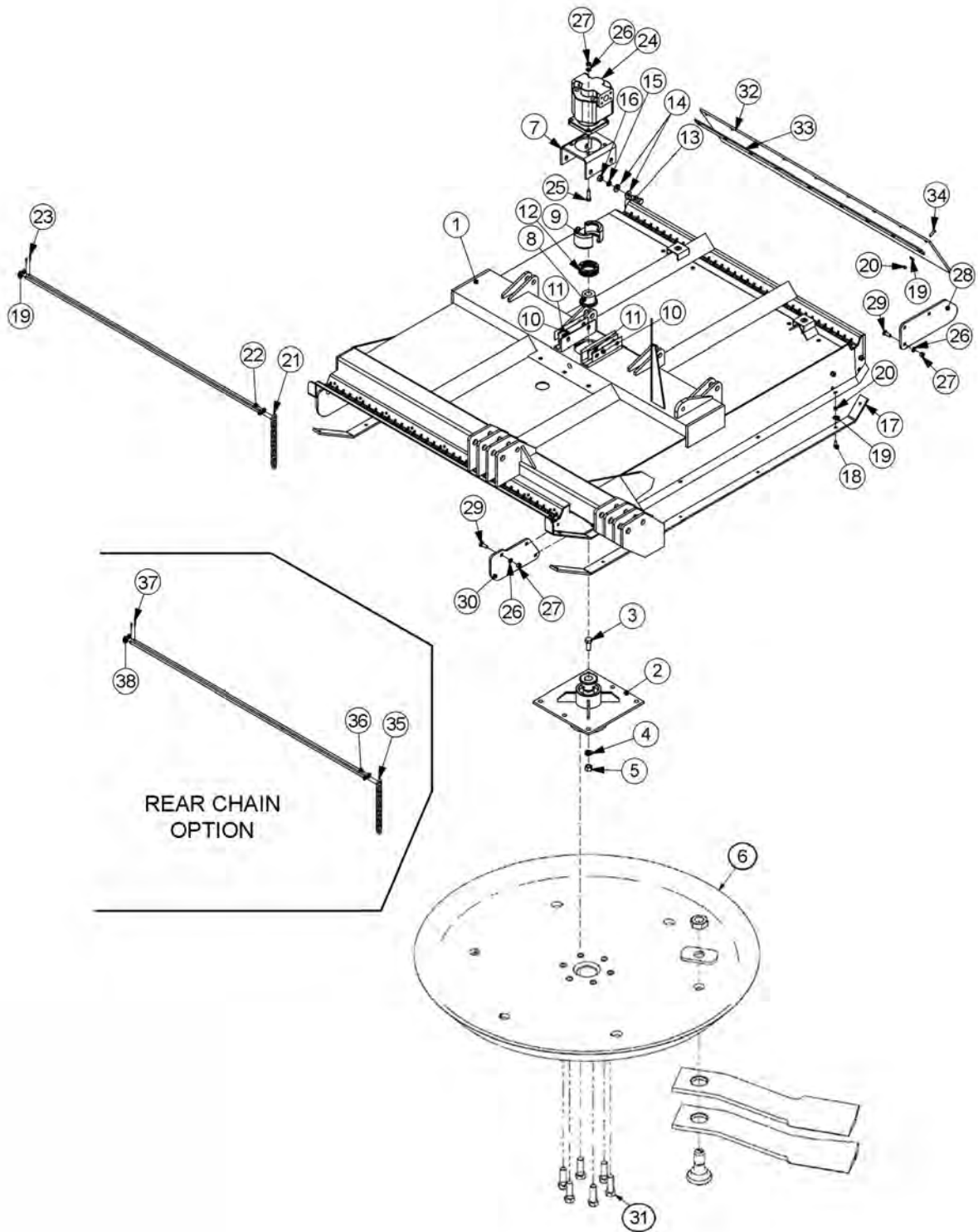

COMMON TWIN

60IN REAR TM ROTARY MOWER

Continued...

| ITEM | PART NO. | QTY. | DESCRIPTION |
|------|----------|------|---------------------------------------|
| --- | 23003 | - | REAR RTRY, 60" W/REAR CHAINS |
| 1 | 32616 | 1 | RTRY, 60" DECK, TRR |
| 2 | 6T1024H5 | 1 | SPINDLE ASSY,CPLT,HD,5/8 HOLES |
| 3 | 6T2277 | 6 | CAPSCREW, 3/4" X 2" NF |
| 4 | 21993 | 6 | LOCKWASHER,3/4",GR 8 |
| 5 | 6T2413 | 6 | HEX NUT,3/4",NF,GR 8 |
| 6 | ----- | - | DISK *REFER TO DISK & KNIVES PAGE |
| 7 | 6T1001 | 1 | BRKT, MOTOR MTG, 60" |
| 8 | 21223 | 1 | SPROKET, 1-1/4" BORE |
| 9 | 6T1033 | 1 | COVER, COUPLING |
| 10 | 6T0822 | 2 | SHIM, MOTOR MOUNT, 14GA. (AS NEEDED) |
| 11 | 6T0822A | 2 | SHIM, MOTOR MOUNT, 18 GA. (AS NEEDED) |
| 12 | 6T1029 | 1 | CHAIN, COUPLING |
| 13 | 21783 | 4 | CAPSCREW, 5/8" X 2",NC |
| 14 | 25270 | 8 | FLATWASHER,5/8", GR 8 |
| 15 | 21992 | 10 | LOCKWASHER, 5/8" |
| 16 | 21775 | 4 | HEX NUT, 5/8" |
| 17 | 23160A | 2 | SKID SHOE |
| 18 | 6T2270 | 12 | PLOW BOLT,3/8" X 1" NC |
| 19 | 22016 | 21 | FLATWASHER,3/8" |
| 20 | 21625 | 21 | HEX NUT,3/8",NC |
| 21 | 22993 | 71 | CHAIN, 5/16" GR30, 9 LINK |
| 22 | 22054 | 2 | ROD, CHAIN HOLDER |
| 23 | 6T3028 | 2 | COTTER PIN, 1/8" X 1" |
| 24 | 06504011 | 1 | MOTOR, (M365 - 2" GEAR) |
| 25 | 21733 | 4 | CAPSCREW, 1/2" X 2",NC |
| 26 | 21990 | 16 | LOCKWASHER, 1/2" |
| 27 | 21725 | 16 | HEX NUT, 1/2" NC |
| 28 | 33656 | 2 | PLATE,GUARD,SAFETY,REAR,RTRY |
| 29 | 6T2267 | 12 | CARRIAGE BOLT, 1/2" X 2" NF, GR8 |
| 30 | 33655 | 2 | PLATE,GAURD,SAFETY,FRONT, RTRY |
| 31 | 6T2290 | 6 | CAPSCREW,5/8" X 2",NF GR 8 |
| 32 | 24347 | 1 | REAR DEFLECTOR FLAP |
| 33 | 24349 | 1 | FLAP MOUNTING BAR |
| 34 | 21631 | 9 | CAPSCREW, 3/8" X 1-1/4" NC |
| 35 | 22992 | 71 | CHAIN, 5/16" GR30, 10 LINK |
| 36 | 22054 | 2 | ROD, CHAIN HOLDER |
| 37 | 6T3028 | 2 | COTTER PIN, 1/8" X 1" |
| 38 | 22016 | 2 | FLATWASHER,3/8" |

COMMON TWIN

60IN REAR TSR ROTARY MOWER

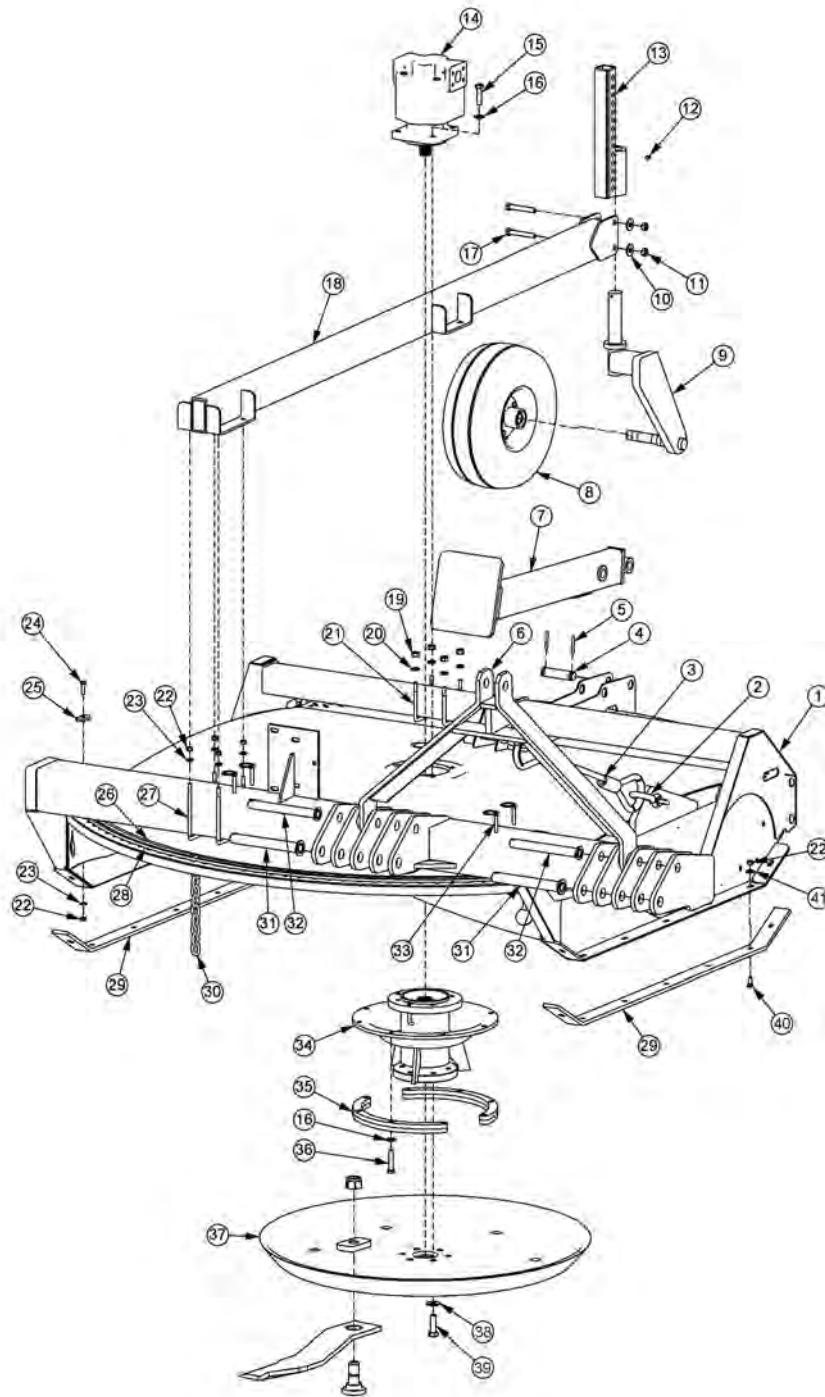

| ITEM | PART NO. | QTY. | DESCRIPTION |
|------|----------|------|--------------------------|
| --- | 06741023 | - | 60IN TSR REAR MOWER ASSY |
| 1 | 06320002 | 1 | TRAILKAT®,60,WLDMNT |
| 2 | 6T0112 | 2 | SHACKLE,W/PIN,CPLT |
| 3 | 22051 | 1 | CABLE,LIFT,TRR,60 |

COMMON TWIN

60IN REAR TSR ROTARY MOWER

Continued...

| ITEM | PART NO. | QTY. | DESCRIPTION |
|------|----------|------|-----------------------------------|
| 4 | 06520425 | 2 | PIN |
| 5 | 06537021 | 4 | ROLLPIN,5MM X 50MM,SS |
| 6 | 21474A | 1 | HITCH,3PT,TRR |
| 7 | 28511 | 1 | STAND,SAFETY SUPPORT W/PAD |
| 8 | 23329 | 1 | CASTER WHL,SOLID TIRE W/SPIND |
| 9 | 22057 | 1 | SPINDLE,CASTER AXLE,ASSY |
| 10 | 22018 | 2 | FLATWASHER,1/2,WIDE |
| 11 | 21725 | 2 | HEX NUT,1/2,NC |
| 12 | 6T3211 | 1 | GREASE ZERK,1/8 |
| 13 | 06370003 | 1 | CASTER ADJ,TRAILKAT |
| 14 | 06504016 | 1 | MOTOR,M365-1 1/4",SPLINE,SEALED |
| 15 | 6T1025 | 4 | CAPSCREW,1/2 X 2,NC,GR8 |
| 16 | 06533004 | 12 | FLATWASHER,1/2,SAE,GR8 |
| 17 | 21738 | 2 | CAPSCREW,1/2 X 3-1/4,NC |
| 18 | 06370004 | 1 | CASTER MNT,TRAILKAT |
| 19 | 21700 | 4 | HEX NUT,1/2,NF |
| 20 | 21990 | 4 | LOCKWASHER,1/2 |
| 21 | 06420003 | 2 | U-BOLT,.50 X 3.25 X 5.00 |
| 22 | 21625 | 20 | HEX NUT,3/8,NC |
| 23 | 21988 | 6 | LOCKWASHER,3/8 |
| 24 | 21631 | 2 | CAPSCREW,3/8 X 1-1/4,NC,GR8 |
| 25 | 34972 | 2 | PLATE,CAP,CHAIN |
| 26 | 34974 | 1 | ROD,CHAIN,INNER,TM60 |
| 27 | 06420005 | 2 | U-BOLT,.38 X 5.63 X 6.31 |
| 28 | 34973 | 1 | ROD,CHAIN,OUTER,TM60 |
| 29 | 06410254 | 2 | SKID SHOE,TSR |
| 30 | 22992 | 78 | CHAIN,10 LINK |
| 31 | 33698 | 2 | PIN,1.13 X 9.00 |
| 32 | 33699 | 2 | PIN,1 X 8.88 |
| 33 | TF1143 | 4 | LYNCH PIN |
| 34 | 34980 | 1 | SPINDLE ASSY,TM60 |
| 35 | 06320011 | 2 | SPACER,TSR,SPINDLE |
| 36 | 06530221 | 8 | CAPSCREW,1/2 X 2-1/4,NF,GR8 |
| 37 | ----- | - | DISK *REFER TO DISK & KNIVES PAGE |
| 38 | 25270 | 6 | FLATWASHER,5/8",USS,GR8 |
| 39 | 6T2290 | 6 | CAPSCREW,5/8" X 2",NF,GR8 |
| 40 | 6T2270 | 14 | PLOW BOLT,3/8" X 1",NC |
| 41 | 22016 | 14 | FLATWASHER,3/8",GR8 |

COMMON TWIN

REAR ROTARY HYDRAULICS

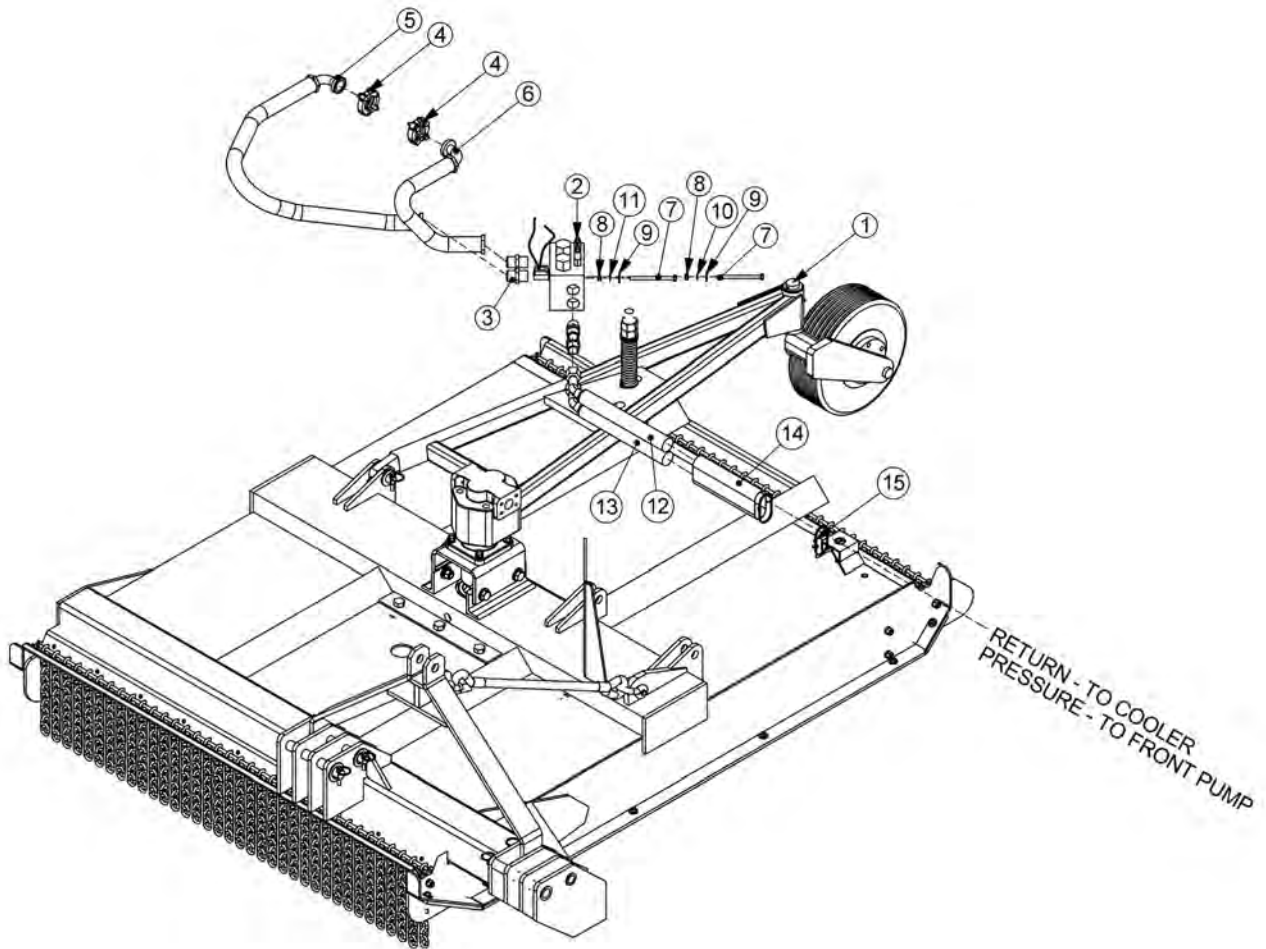

REAR ROTARY HYDRAULICS

Continued...

| ITEM | PART NO. | QTY. | DESCRIPTION |
|------|----------|------|--|
| 1 | ----- | - | REAR ROTARY MOWER |
| 2 | 06510083 | 1 | VALVE,BRAKE,SOL,3000PSI,METRI |
| 3 | 33555 | 4 | ADAPTER,1MORB X 1MJIC (3 FOR TSR) |
| --- | 33554 | 1 | ELBOW,1MORB X 1MJIC,45 (TSR PRESSURE TO MOTOR) |
| 4 | TF4852 | 2 | KIT, FLANGE, #20 |
| 5 | 34198 | 1 | HOSE, 1" X 40" (TM MOWER RETURN) |
| --- | 06500087 | - | HOSE, 1" X 42" (TSR MOWER RETURN) |
| 6 | 34197 | 1 | HOSE, 1" X 33" (TM MOWER PRESSURE) |
| --- | 06500086 | - | HOSE, 1" X 24" (TSR MOWER PRESSURE) |
| 7 | 21644 | 2 | CAPSCREW,3/8" X 5" NC |
| 8 | 21625 | 2 | HEX NUT,3/8",NC |
| 9 | 22016 | 2 | FLATWASHER,3/8" |
| 10 | 21988 | 1 | LOCKWASHER, 3/8" |
| 11 | 6T2665 | 1 | STAR LOCKWASHER, 3/8" |
| 12 | ----- | 1 | HOSE (RETURN) |
| 13 | ----- | 1 | HOSE (PRESSURE) |
| 14 | 33930 | 1 | HOSE SLEEVE, TRR |
| 15 | 6T1823 | 2 | ZIP TIE, 14" STRAPS |

COMMON TWIN

60IN SIDE TM CHAIN GUARDS

STANDARD FRONT CHAIN GUARD

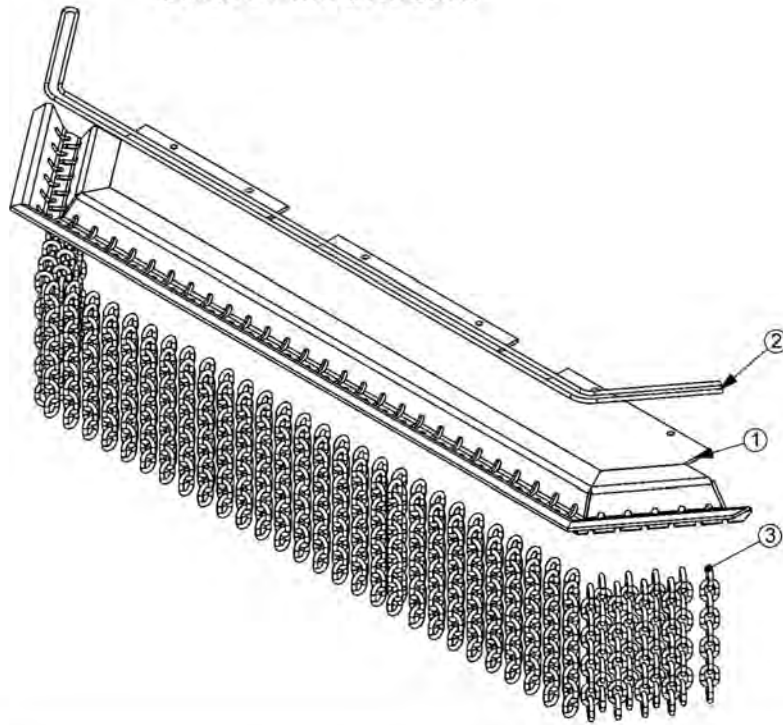

OPTIONAL REAR CHAIN GUARD

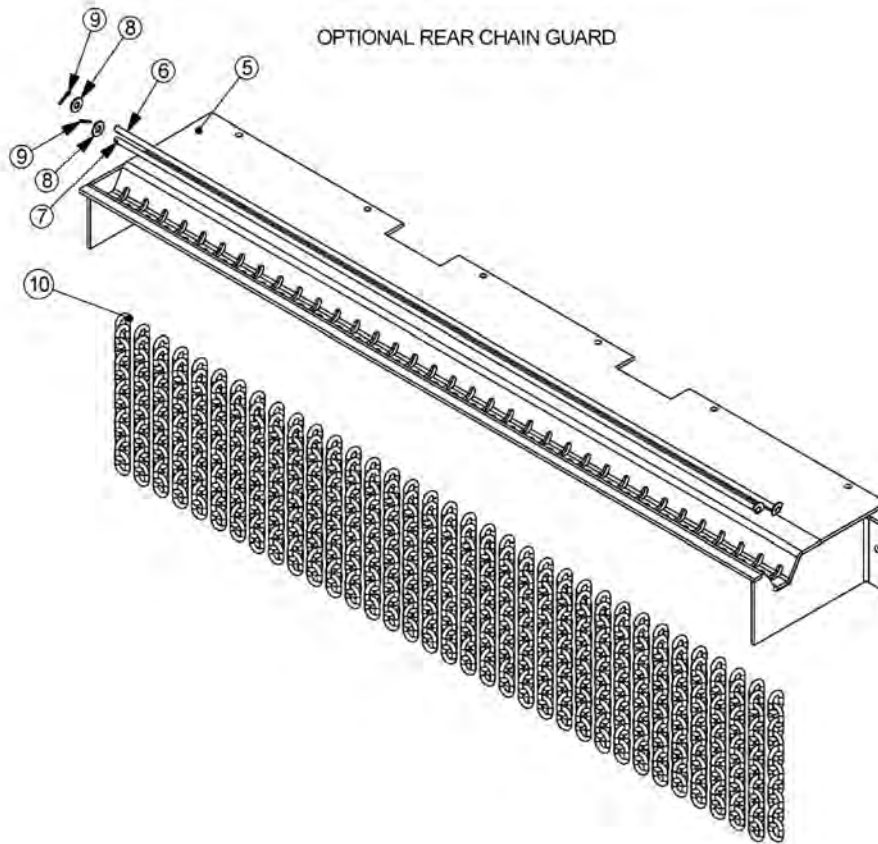

60IN SIDE TM CHAIN GUARDS

Continued...

| ITEM | PART NO. | QTY. | DESCRIPTION |
|------|----------|------|--------------------------------|
| --- | 31773 | - | GUARD,CHAIN,TM60,FRONT,ASSY |
| 1 | 31762 | 1 | GUARD,CHAIN,TM60,FRONT |
| 2 | 28407 | 12 | CABLE,5/16",BULK (QTY IN FEET) |
| 3 | 22993 | 77 | CHAIN,5/16",GR30,9 LINK |
| 4 | 28408 | 4 | U-BOLT,CABLE,5/16" (NOT SHOWN) |
| --- | 31774 | - | GUARD,CHAIN,TM60,REAR,ASSY |
| 5 | 31763 | 1 | GUARD,CHAIN,TM60,REAR |
| 6 | 31879 | 1 | ROD,SHORT,TM60 |
| 7 | 31878 | 1 | ROD,LONG,TM60 |
| 8 | 22016 | 2 | FLATWASHER,3/8",GR8 |
| 9 | 6T3028 | 2 | COTTER PIN,1/8" X 1" |
| 10 | 22992 | 69 | CHAIN,5/16",GR30,10 LINK |

COMMON TWIN

72IN SIDE TM CHAIN GUARDS

STANDARD FRONT CHAIN GUARD

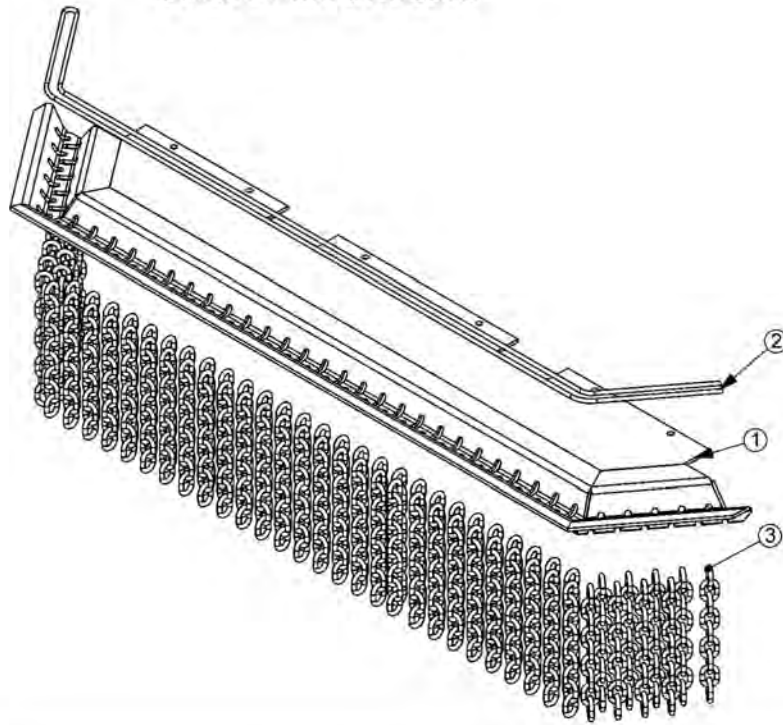

OPTIONAL REAR CHAIN GUARD

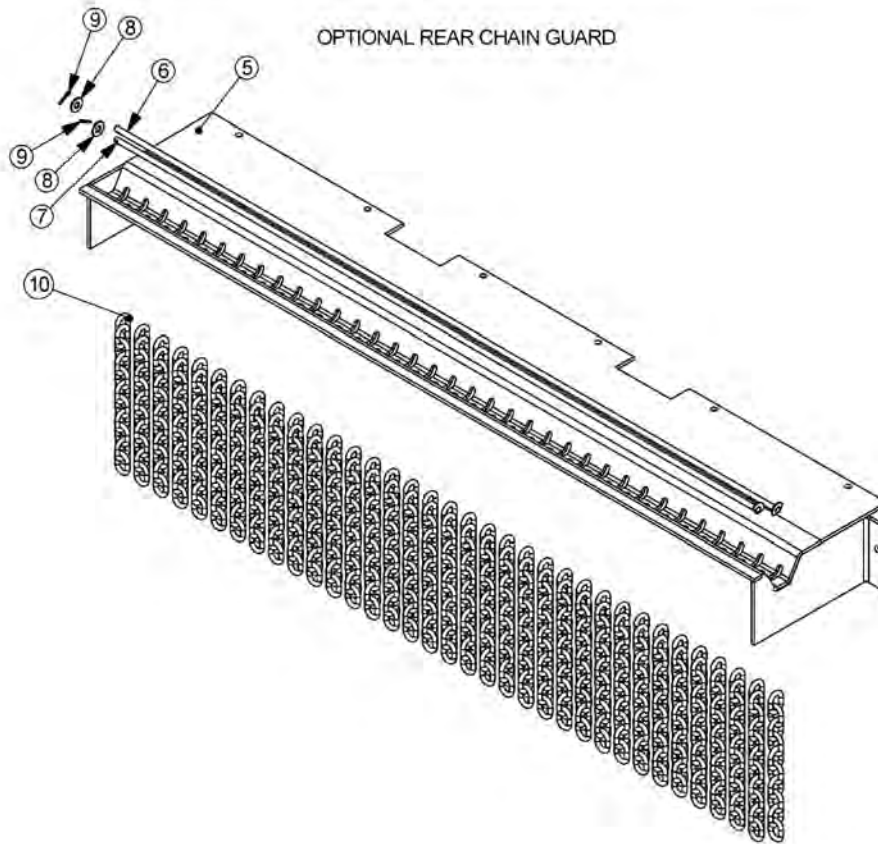

72IN SIDE TM CHAIN GUARDS

Continued...

| ITEM | PART NO. | QTY. | DESCRIPTION |
|------|----------|------|--------------------------------|
| --- | 31931 | - | GUARD,CHAIN,TM72,FRONT,ASSY |
| 1 | 31863 | 1 | GUARD,CHAIN,TM72,FRONT |
| 2 | 28407 | 14 | CABLE,5/16",BULK (QTY IN FEET) |
| 3 | 22993 | 91 | CHAIN,5/16",GR30,9 LINK |
| 4 | 28408 | 4 | U-BOLT,CABLE,5/16" (NOT SHOWN) |
| --- | 31932 | - | GUARD,CHAIN,TM60,REAR,ASSY |
| 5 | 31864 | 1 | GUARD,CHAIN,TM60,REAR |
| 6 | 31934 | 1 | ROD,LONG,TM72 |
| 7 | 31933 | 1 | ROD,SHORT,TM72 |
| 8 | 22016 | 2 | FLATWASHER,3/8",GR8 |
| 9 | 6T3028 | 2 | COTTER PIN,1/8" X 1" |
| 10 | 22992 | 83 | CHAIN,5/16",GR30,10 LINK |

COMMON TWIN

60IN TSR REAR GUARDS

OPTIONAL REAR CHAIN GUARD

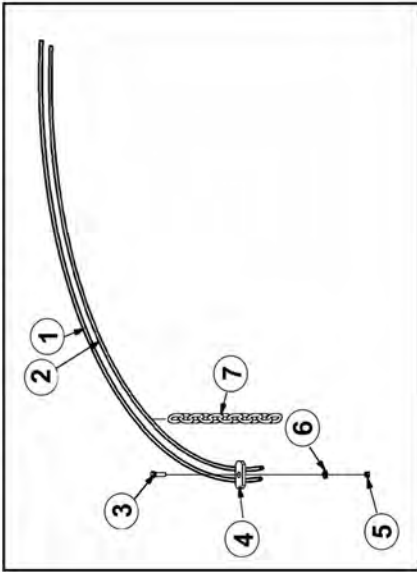

STANDARD SQUARE REAR FLAP GUARD

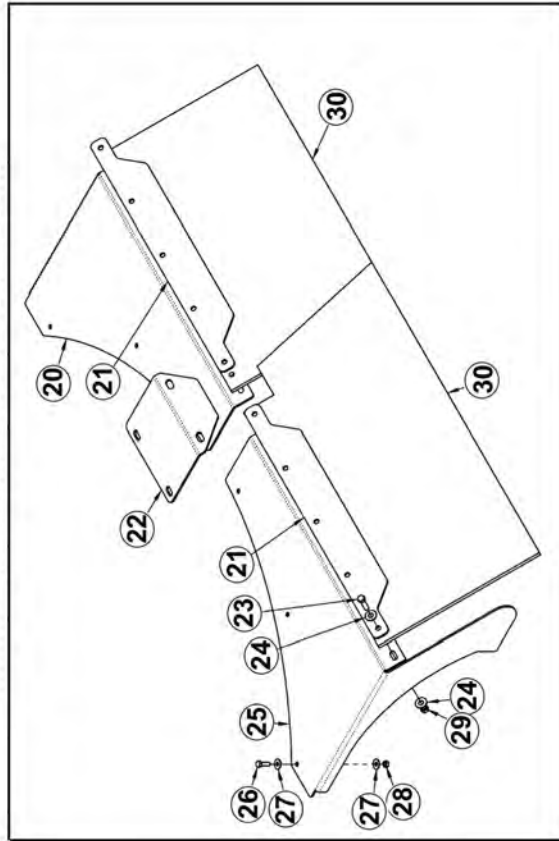

60IN TSR REAR GUARDS

Continued...

| ITEM | PART NO. | QTY. | DESCRIPTION |
|------|----------|------|---------------------------|
| 1 | 34973 | 2 | ROD,CHAIN,OUTER,TM60 |
| 2 | 34974 | 2 | ROD,CHAIN,INNER,TM60 |
| 3 | 21631 | 16 | CAPSCREW, 3/8 X 1-1/4,NC |
| 4 | 34972 | 4 | PLATE,CAP,CHAIN |
| 5 | 21625 | 30 | HEX NUT,3/8",NC |
| 6 | 21988 | 16 | LOCKWASHER, 3/8" |
| 7 | 22992 | 156 | CHAIN,10 LINK |
| 20 | 06410947 | 1 | MNT,FLAP,RH,EXT,TSR |
| 21 | 06401184 | 2 | STRAP,FLAP,EXT,TSR |
| 22 | 06410948 | 1 | COVER,FLAP,EXT,TSR |
| 23 | 21632 | 10 | CAPSCREW,3/8" X 1-1/2" NC |
| 24 | 22016 | 20 | FLATWASHER,3/8",GR8 |
| 25 | 06410946 | 1 | MNT,FLAP,LH,EXT,TSR |
| 26 | 21580 | 6 | CAPSCREW,5/16 X 1 NC |
| 27 | 22015 | 12 | FLATWASHER,5/16 |
| 28 | 21577 | 6 | NYLOCK NUT, 5/16,NC |
| 29 | 21625 | 10 | HEX NUT,3/8",NC |
| 30 | 06520331 | 2 | FLAP,EXT,TSR |

COMMON TWIN

TM MOWER SPINDLE ASSEMBLY

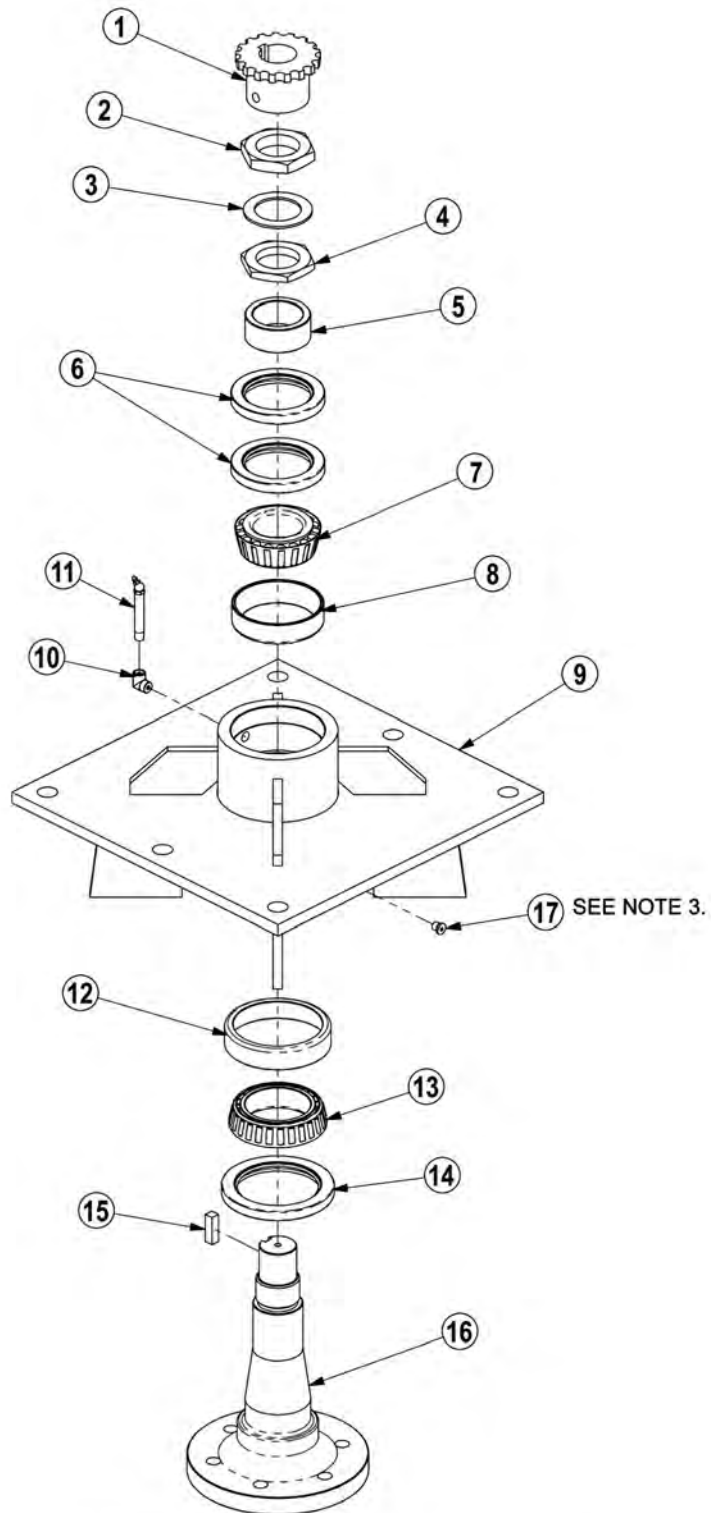

NOTES:

1. FREEPLAY: .001" - .003"
2. GREASE: FILL WITH MOBILITH SHC 220.
3. APPLY LOCTITE "271" TO O-RING PLUG THRDS.

TM MOWER SPINDLE ASSEMBLY

Continued...

| ITEM | PART NO. | QTY. | DESCRIPTION |
|------|-----------|------|--|
| --- | 6T1024H5 | - | SPINDLE ASSEMBLY COMPLETE |
| 1 | 6T1031 | 1 | SPROCKET |
| 2 | 6T1016 | 1 | BEARING LOCK NUT - THICK |
| 3 | 22596 | 1 | JAM WASHER |
| 4 | 6T1015 | 1 | BEARING ADJUSTMENT NUT - THIN |
| 5 | 6T1014 | 1 | BEARING ADJUSTMENT SLEEVE |
| 6 | 6T1011 | 1 | UPPER SEAL - SET OF 2 |
| 7 | 6T1012 | 1 | BEARING CONE |
| 8 | 6T1013 | 1 | BEARING CUP |
| 9 | 6T1010H | 1 | SPINDLE HOUSING |
| 10 | 30570 | 1 | FITTING STREET ELBOW |
| 11 | 33990 | 1 | GREASE ZERK |
| 12 | 6T1013H | 1 | BEARING CUP |
| 13 | 6T1012H | 1 | BEARING CONE |
| 14 | 6T1011H | 1 | LOWER SEAL |
| 15 | 6T1019 | 1 | SPINDLE KEY |
| 16 | PT1018H-5 | 1 | SPINDLE |
| 17 | 06503064 | 1 | O-RING PLUG, 1/8" |
| --- | 31771 | - | SPINDLE REBUILD KIT (INCLUDES ITEMS 2 - 8 AND 12 - 15) |

COMMON TWIN

TSR MOWER SPINDLE ASSEMBLY

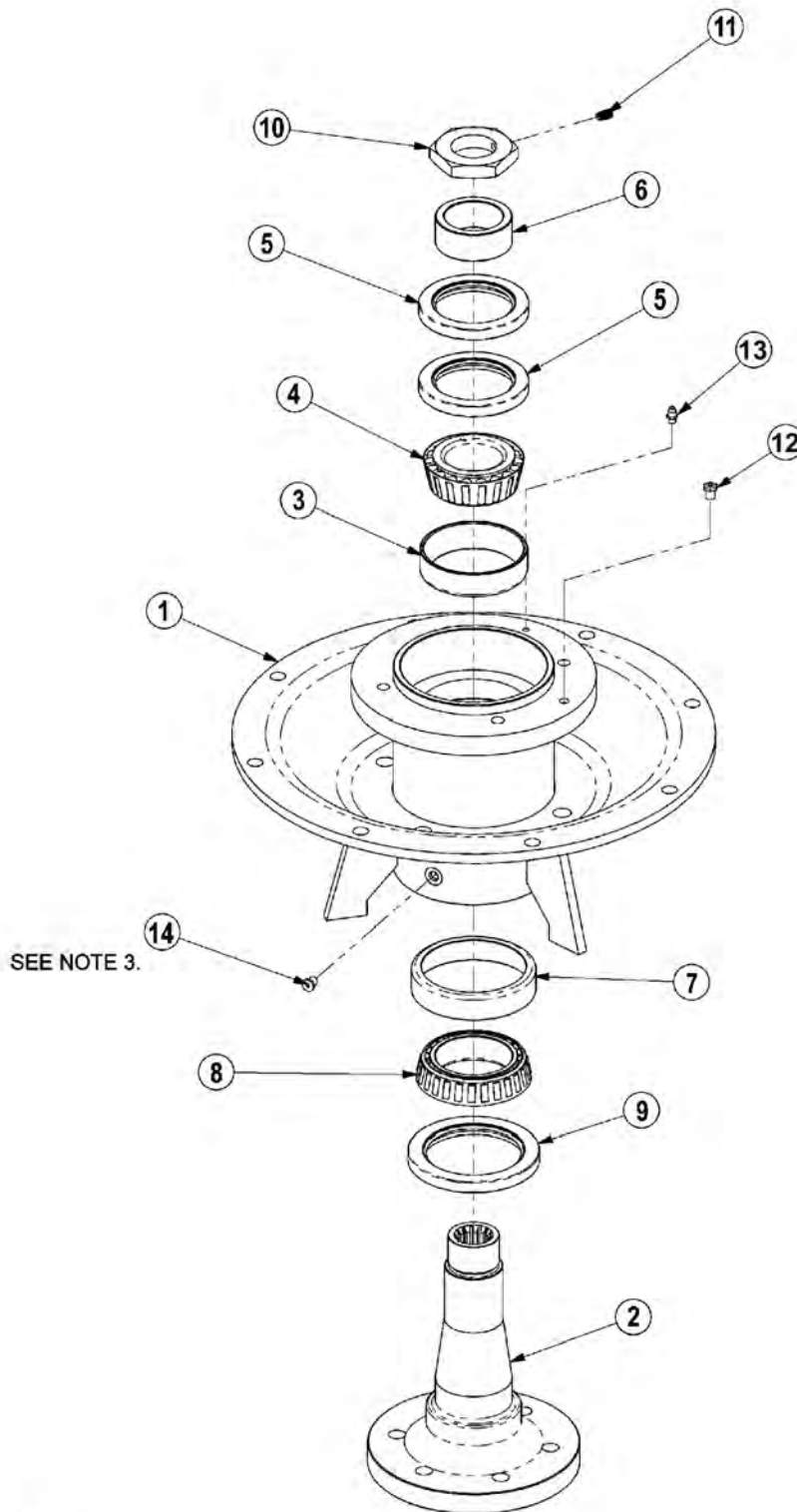

NOTES:

1. FREEPLAY: .001" - .003"
2. GREASE: FILL WITH MOBILITH SHC 220.
3. APPLY LOCTITE "271" TO O-RING PLUG THRDS.

TSR MOWER SPINDLE ASSEMBLY

Continued...

| ITEM | PART NO. | QTY. | DESCRIPTION |
|------|----------|------|---------------------------|
| --- | 34980 | - | SPINDLE ASSEMBLY COMPLETE |
| 1 | 34978 | 1 | SPINDLE MOUNT |
| 2 | 34979 | 1 | SPINDLE,TM60 |
| 3 | 6T1013 | 1 | BEARING CUP |
| 4 | 6T1012 | 1 | BEARING CONE |
| 5 | 6T1011 | 1 | UPPER SEAL - SET OF 2 |
| 6 | 6T1014 | 1 | BEARING ADJUSTMENT SLEEVE |
| 7 | 6T1013H | 1 | BEARING,CUP,HD |
| 8 | 6T1012H | 1 | BEARING CONE,HD |
| 9 | 6T1011H | 1 | SEAL,LOWER,HD |
| 10 | 34985 | 1 | NUT W/SETSCREW |
| 11 | 6T2275 | 1 | SETSCREW,5/16" X 1/2",NC |
| 12 | 34988 | 1 | RELIEF,1PSI,1/8" NPT |
| 13 | 6T3207 | 1 | ZERK,1/4" X STR |
| 14 | 06503064 | 1 | O-RING PLUG, 1/8" |

COMMON TWIN

ROTARY DISK AND KNIVES

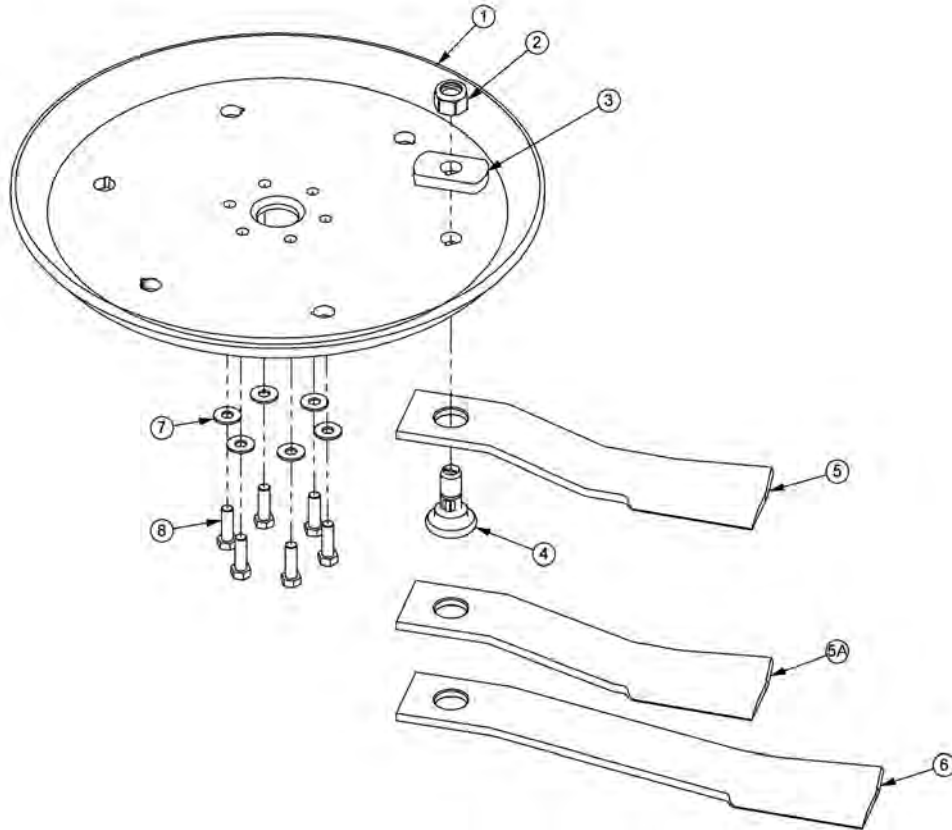

| ITEM | PART NO. | QTY. | DESCRIPTION |
|------|----------|------|--|
| 1 | 34876 | 1 | BLADE MOUNTING DISK |
| 2 | 6T1023R | 2 | NYLOCK NUT,1-1/8" |
| 3 | 34878 | 2 | SPACER |
| 4 | 34497 | 2 | KNIFE MOUNTING BOLT |
| 5 | 34685 | 2 | KNIFE,60" HIGH SUCTION - STANDARD |
| 5A | 34684 | 2 | KNIFE,60" - OPTIONAL |
| 6 | 34682 | 2 | KNIFE 72" (MOUNT ON 72" MOWER ONLY) |
| 7 | 25270 | 6 | FLATWASHER,5/8",USS,GR8 |
| 8 | 6T2259 | 6 | CAPSCREW,5/8" X 1-3/4",NF |
| ---- | 6T1825 | - | LOCTITE - USED ON ALL DISK MOUNTING BOLTS |
| --- | 27167 | - | BOLT KIT (INCLUDE ITEMS 7 & 8) |
| ---- | 06700002 | - | KIT,60/72,DISK,KNF MTG (INCLUDE ITEM 1, 3,7 & 8) |

COMMON TWIN

NOTES

NOTES

SIDE ROTARY CASTER WHEEL ASSEMBLY

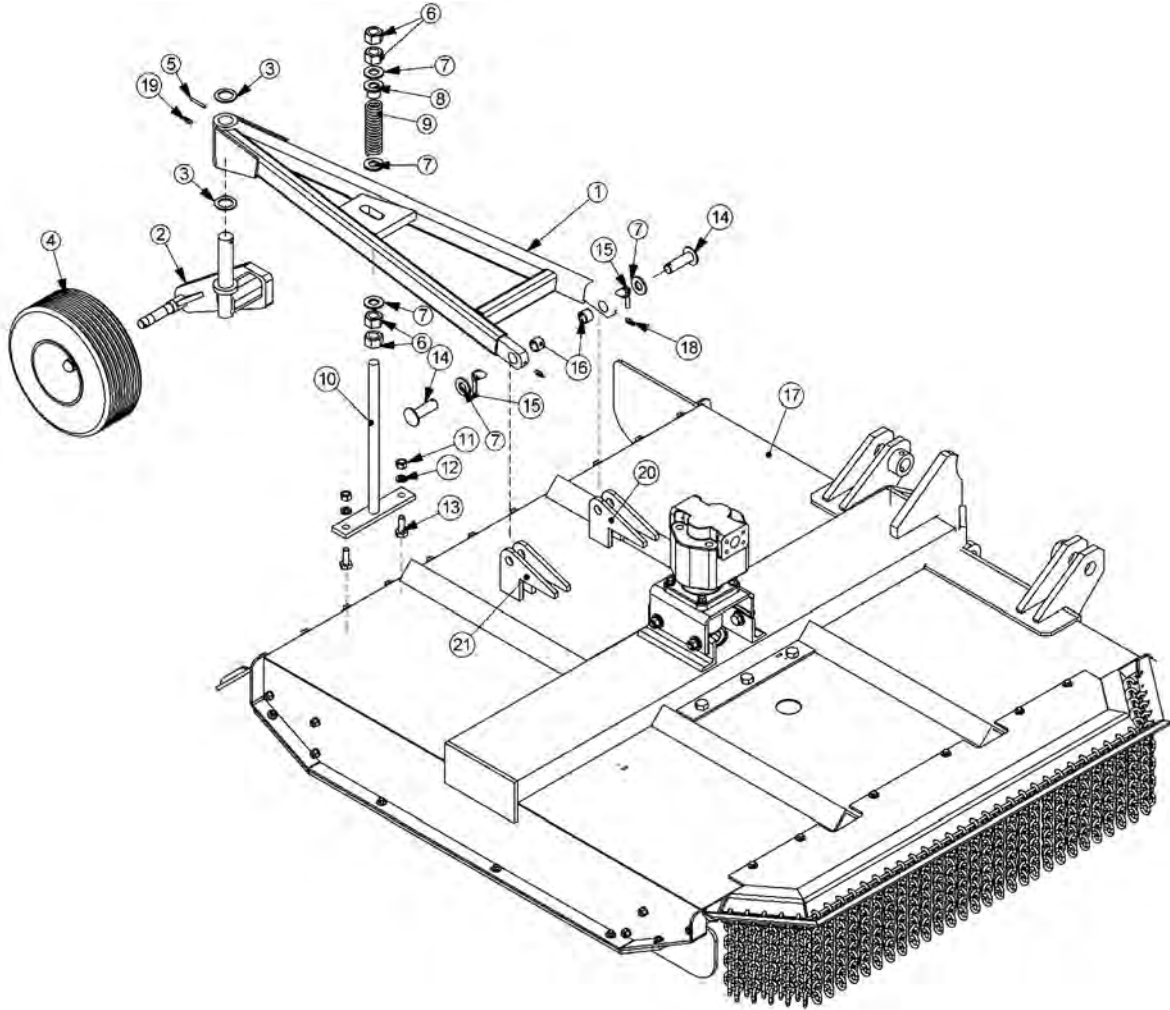

SIDE ROTARY CASTER WHEEL ASSEMBLY

Continued...

| ITEM | PART NO. | QTY. | DESCRIPTION |
|------|----------|------|-------------------------------|
| 1 | 25214C | 1 | FRAME,CASTER,WHL (TM60) |
| --- | 28297A | - | FRAME,CASTER WHL (TM72) |
| 2 | 22057 | 1 | SPINDLE,CASTER AXLE,ASSY |
| 3 | 6T2617 | 2 | BUSHING,MACH,1-1/2IDX 2-1/4OD |
| 4 | 28548 | 1 | CASTER WHEEL,SOLID TIRE |
| --- | 22065 | 1 | HUB,ASSY,CASTER |
| ---- | 22066 | 1 | HUB,CASTER |
| --- | 22070 | 1 | DUST CAP |
| ---- | 22071 | 5 | HUB STUD |
| --- | 22073 | 1 | HEX NUT,1",NF (SLOTTED) |
| ---- | 22533 | 1 | COTTER PIN,3/16" X 2" |
| --- | 6T0830 | 2 | BEARING,CONE,CASTER WHEEL |
| ---- | 6T0838 | 1 | SEAL |
| --- | 23329 | 1 | WHEEL,CPLT,SOLID TIRE |
| ---- | 21416 | 1 | TIRE,SOLID |
| --- | 22697 | 1 | RIM,OUTER |
| ---- | 22696 | 1 | RIM,CASTER |
| 5 | 6T3014 | 1 | ROLL PIN,1/4" X 2" |
| 6 | 21925 | 4 | HEX NUT,1",NC |
| 7 | 22023 | 5 | FLATWASHER,1" |
| 8 | 22753 | 1 | TUBE,PROTECTOR |
| 9 | 22058 | 1 | SPRING,REAR RTRY |
| 10 | 22059B | 1 | ADJ ROD,TRR |
| 11 | 21775 | 2 | HEX NUT,5/8" |
| 12 | 21992 | 2 | LOCKWASHER,5/8" |
| 13 | 21782 | 2 | CAPSCREW,5/8" X 1-3/4",NC |
| 14 | 22060 | 2 | CASTER FRAME PIN |
| 15 | TF1143 | 2 | PIN,LYNCH,7/16" X 2" |
| 16 | TB3010 | 2 | BUSHING,1" |
| 17 | ----- | 1 | RTRY,CPLT,TM |
| 18 | 6T3207 | 2 | GREASE ZERK,1/4" X STR |
| 19 | 6T3211 | 1 | GREASE ZERK,1/8" X STR |
| 20 | 21441 | 2 | CASTER FRAME ANCHOR (TM60) |
| --- | 42527 | 2 | CASTER FRAME ANCHOR (TM72) |
| 21 | 21442 | 2 | CASTER FRAME ANCHOR (TM60) |
| --- | 42527 | 2 | CASTER FRAME ANCHOR (TM72) |

COMMON TWIN

60IN TM REAR CASTER WHEEL & 3PT ASSY

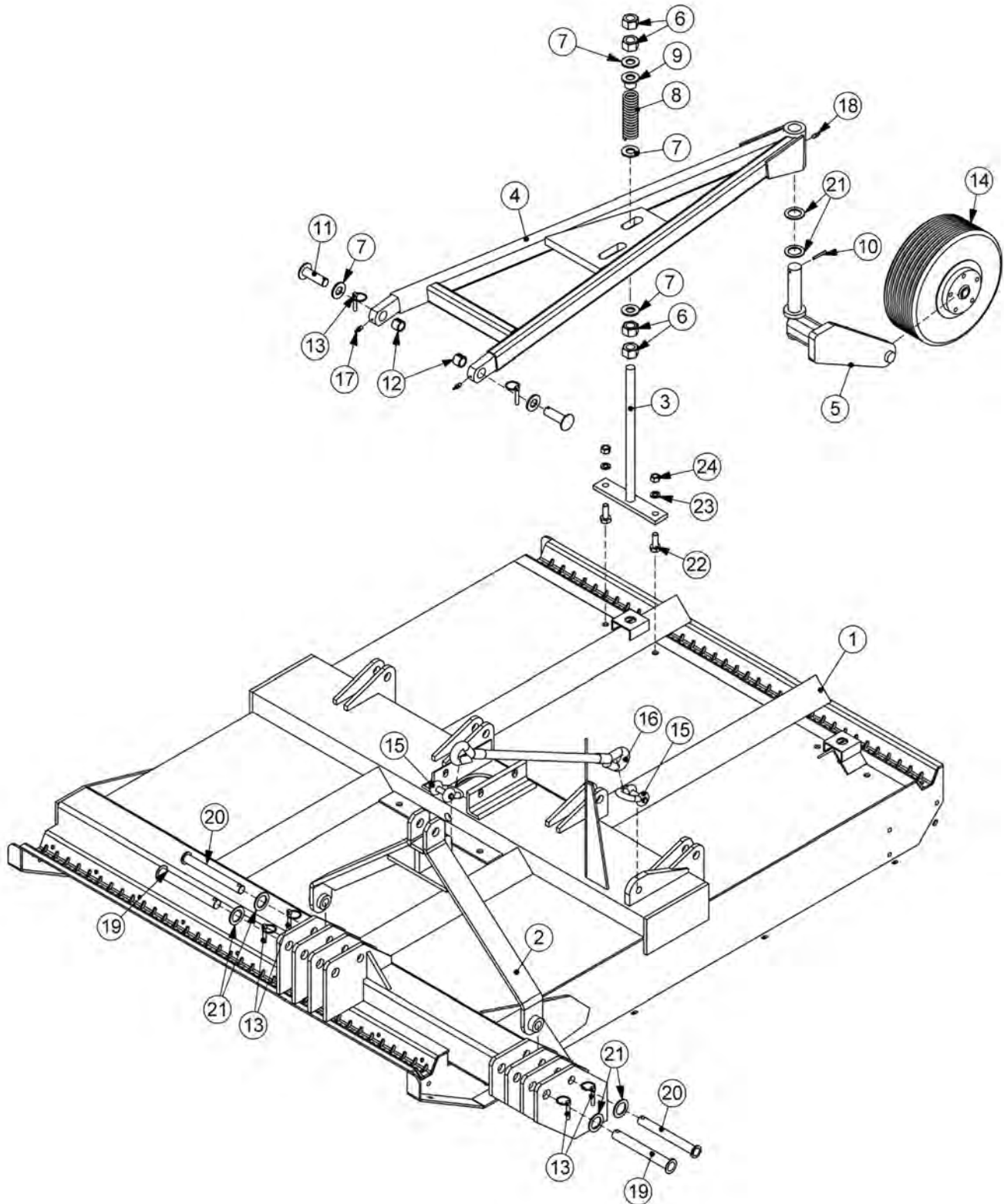

60IN TM REAR CASTER WHEEL & 3PT ASSY

Continued...

| ITEM | PART NO. | QTY. | DESCRIPTION |
|-------------|-----------------|-------------|-------------------------------|
| 1 | ----- | - | MOWER,REAR,60IN,TM |
| 2 | 21474A | 1 | HITCH, 3PT, TRR |
| 3 | 22059B | 1 | ADJ ROD, TRR |
| 4 | 25095A | 1 | FRAME, CASTER WHEEL, TRR 60" |
| 5 | 22057 | 1 | SPINDLE, CASTER AXLE, ASSY |
| 6 | 21925 | 4 | HEX NUT,1" NC |
| 7 | 22023 | 5 | FLATWASHER,1" |
| 8 | 22058 | 1 | SPRING, REAR RTRY |
| 9 | 22753 | 1 | TUBE, PROTECTOR |
| 10 | 6T3014 | 1 | ROLL PIN, 1/4" X 2" |
| 11 | 22060 | 2 | CASTER FRAME PIN |
| 12 | TB3010 | 2 | BUSHING,1" |
| 13 | TF1143 | 6 | PIN, LYNCH, 7/16" X 2" |
| 14 | 28548 | 1 | CASTER WHEEL, SOLID TIRE |
| 15 | 6T0112 | 2 | SHACKLE, W/PIN, CPLT |
| 16 | 22051 | 1 | CABLE, LIFT, TRR, 60" |
| 17 | 6T3207 | 2 | GREASE ZERK,1/4" X STR |
| 18 | 6T3211 | 1 | GREASE ZERK,1/8" X STR |
| 19 | 33698 | 2 | PIN, CAPPED, 1-1/8" X 9" |
| 20 | 33699 | 2 | PIN, CAPPED, 1" X 9" |
| 21 | 6T2617 | 6 | BUSHING,MACH,1-1/2IDX 2-1/4OD |
| 22 | 21782 | 2 | CAPSCREW, 5/8 X 1 3/4,NC |
| 23 | 21992 | 2 | LOCKWASHER, 5/8 |
| 24 | 21775 | 2 | HEX NUT, 5/8 |

COMMON TWIN

CASTER WHEEL ASSEMBLY

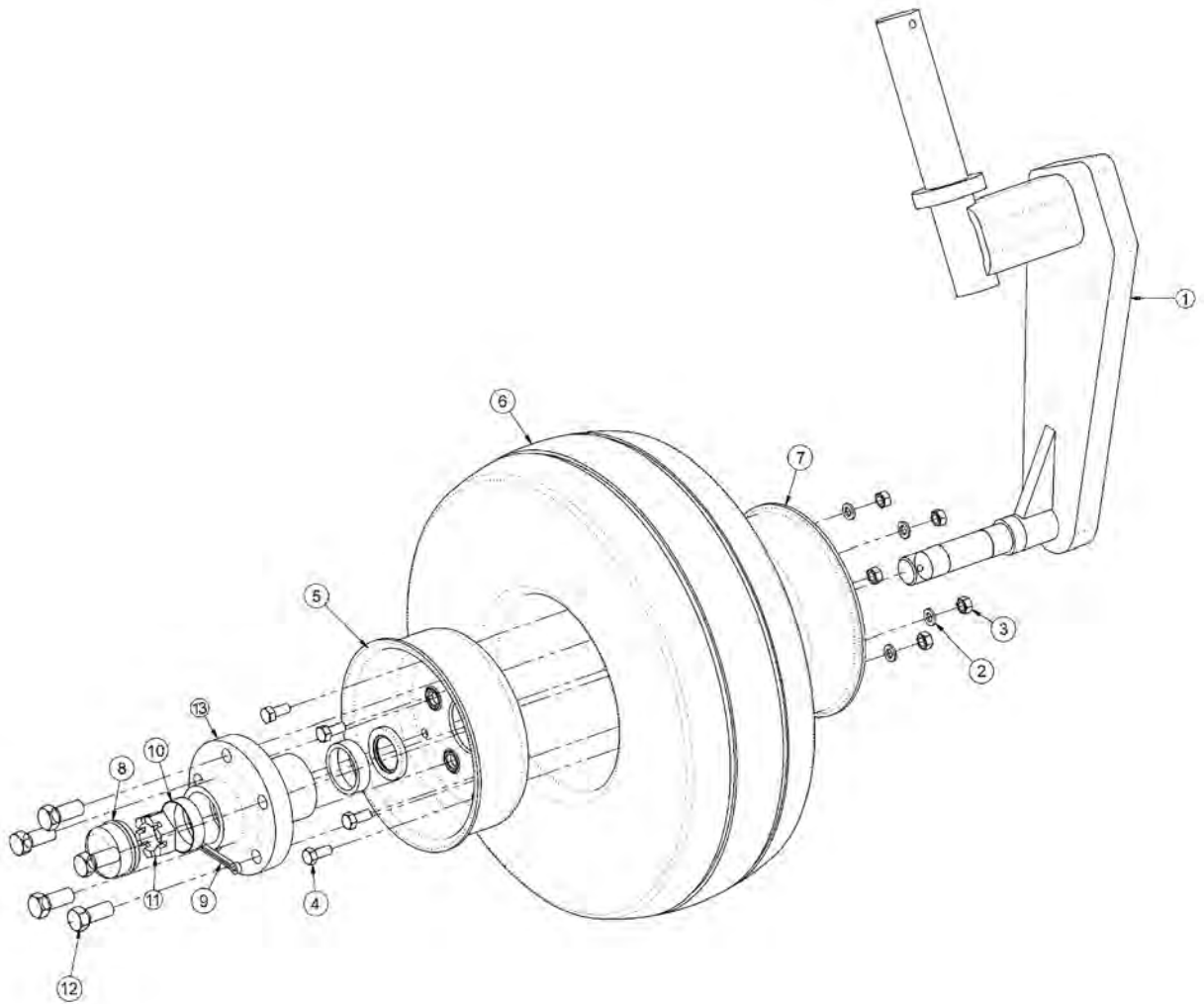

| ITEM | PART NO. | QTY. | DESCRIPTION |
|------|----------|------|---------------------------------|
| 1 | 22057 | 1 | SPINDLE,CASTER AXLE,ASSY |
| 2 | 21987 | 5 | LOCKWASHER,5/16" |
| 3 | 21575 | 5 | HEX NUT,5/16" |
| 4 | 28548 | 5 | CAPSCREW,5/16" X 3/4",NC |
| 5 | 22697 | 1 | RIM,OUTER,CASTER ASSY |
| 6 | 21416 | 1 | TIRE,SOLID |
| 7 | 22696 | 1 | RIM,CASTER WHEEL |
| 8 | 22070 | 1 | DUST CAP |
| 9 | 22533 | 1 | COTTER PIN,3/16" X 2" |
| 10 | 6T0836 | 2 | CUP,CASTER WHEEL |
| 11 | 22073 | 1 | HEX NUT,1",NF (SLOTTED JAM NUT) |
| 12 | 22071 | 5 | HUB STUD |
| 13 | 22066 | 1 | HUB,CASTER WHEEL |

COMMON TWIN

SAFETY STAND

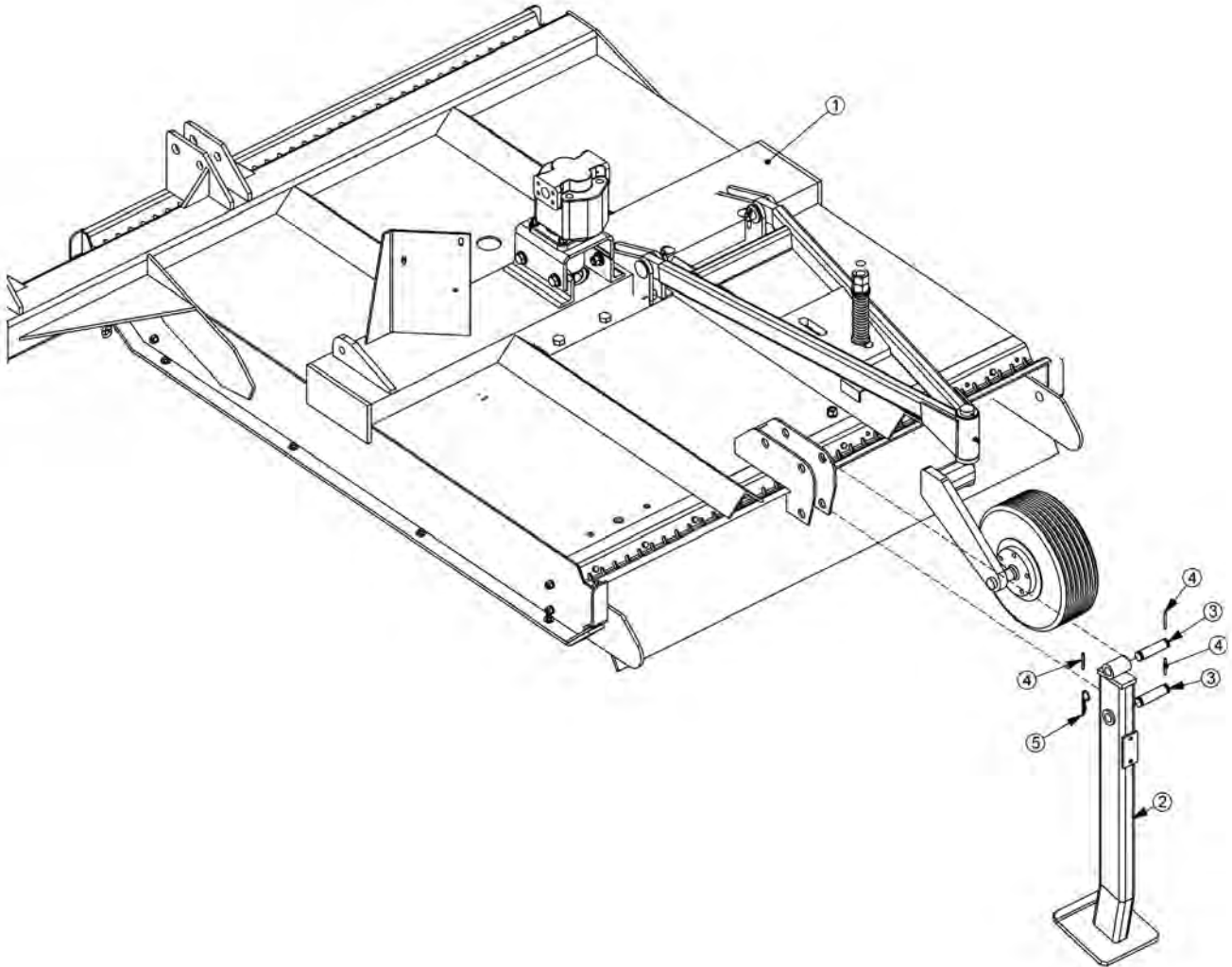

| ITEM | PART NO. | QTY. | DESCRIPTION |
|------|----------|------|--|
| 1 | ----- | - | REAR RTRY - REFER TO REAR RTRY DECK ASSY |
| 2 | 28511 | 1 | REAR RTRY STAND |
| 3 | 06520425 | 2 | PIN |
| 4 | 6T3014 | 3 | ROLL PIN, 1/4" X 2" |
| 5 | 6T3004 | 1 | R-CLIP (HAIRPIN COTTER, 3/16") |

COMMON TWIN

3IN X 10IN HYDRAULIC CYLINDER BREAKDOWN

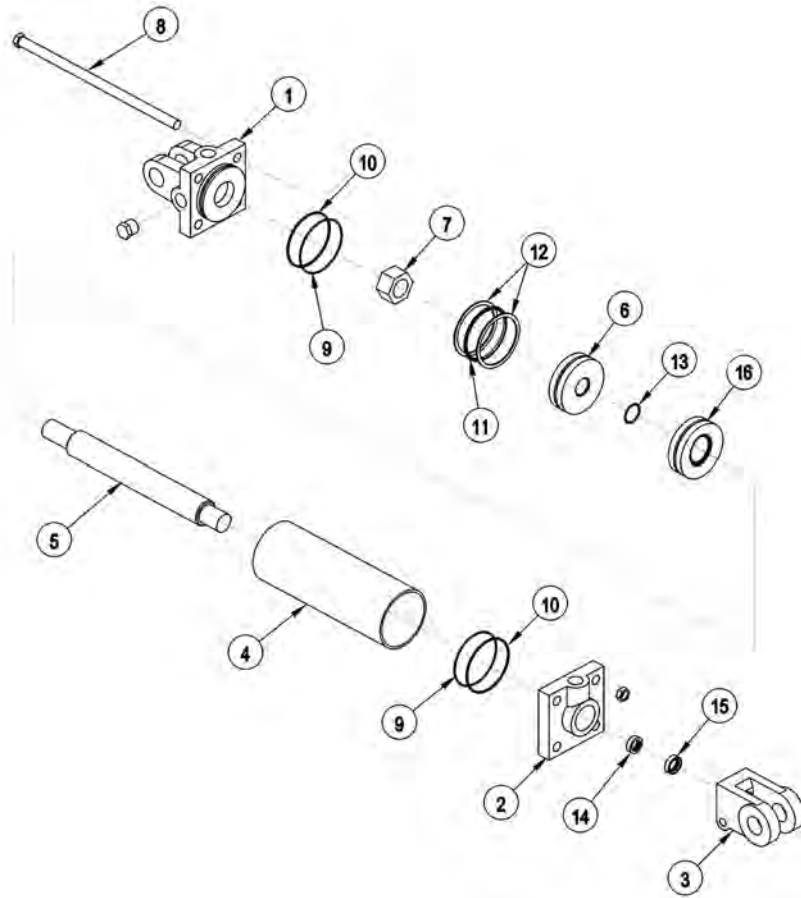

| ITEM | PART NO. | QTY. | DESCRIPTION |
|------|----------|------|------------------------|
| --- | 6T0151R | - | HYD. CYLINDER 3" X 10" |
| 1 | 6T0167 | 1 | CYLINDER BUTT |
| 2 | 6T0170 | 1 | CYLINDER GLAND |
| 3 | 6T0178 | 1 | CLEVIS END |
| 4 | 6T0164 | 1 | CYLINDER TUBE |
| 5 | 6T0161 | 1 | PISTON ROD |
| 6 | 6T0173 | 1 | PISTON |
| 7 | 6T0179 | 1 | LOCKNUT |
| 8 | 6T0176 | 4 | TIE ROD ASY |
| --- | 6T0187 | - | SEAL KIT |
| 9 | ----- | 2 | O - RING |
| 10 | ----- | 2 | BACK - UP WASHER |
| 11 | ----- | 1 | O - RING |
| 12 | ----- | 2 | BACK - UP WASHER |
| 13 | ----- | 1 | O - RING |
| 14 | ----- | 1 | U - CUP |
| 15 | ----- | 1 | WIPER |

COMMON TWIN

3IN X 12IN HYDRAULIC CYLINDER BREAKDOWN

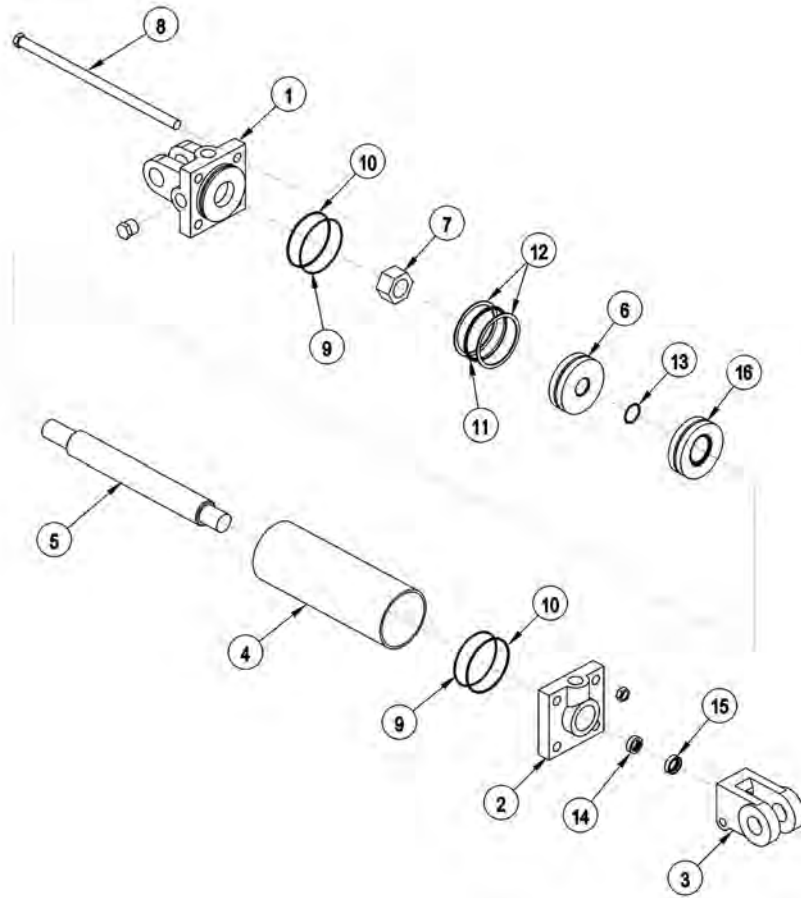

| ITEM | PART NO. | QTY. | DESCRIPTION |
|------|----------|------|-----------------------------------|
| ---- | 32215 | - | HYD. CYLINDER 3" X 12" (STD DUTY) |
| --- | 25343 | - | HYD. CYLINDER 3" X 12" (HVY DUTY) |
| 1 | 6T0167 | 1 | CYLINDER BUTT |
| 2 | 6T0170 | 1 | CYLINDER GLAND |
| 3 | 6T0178 | 1 | CLEVIS END |
| 4 | 6T0204 | 1 | CYLINDER TUBE |
| 5 | 6T0203 | 1 | PISTON ROD |
| 6 | 6T0173 | 1 | PISTON |
| 7 | 6T0179 | 1 | LOCKNUT |
| 8 | 6T0205 | 4 | TIE ROD ASY |
| --- | 6T0187 | - | SEAL KIT |
| 9 | ----- | 2 | O - RING |
| 10 | ----- | 2 | BACK - UP WASHER |
| 11 | ----- | 1 | O - RING |
| 12 | ----- | 2 | BACK - UP WASHER |
| 13 | ----- | 1 | O - RING |
| 14 | ----- | 1 | U - CUP |
| 15 | ----- | 1 | WIPER |

COMMON TWIN

3IN X 18IN HYDRAULIC CYLINDER BREAKDOWN

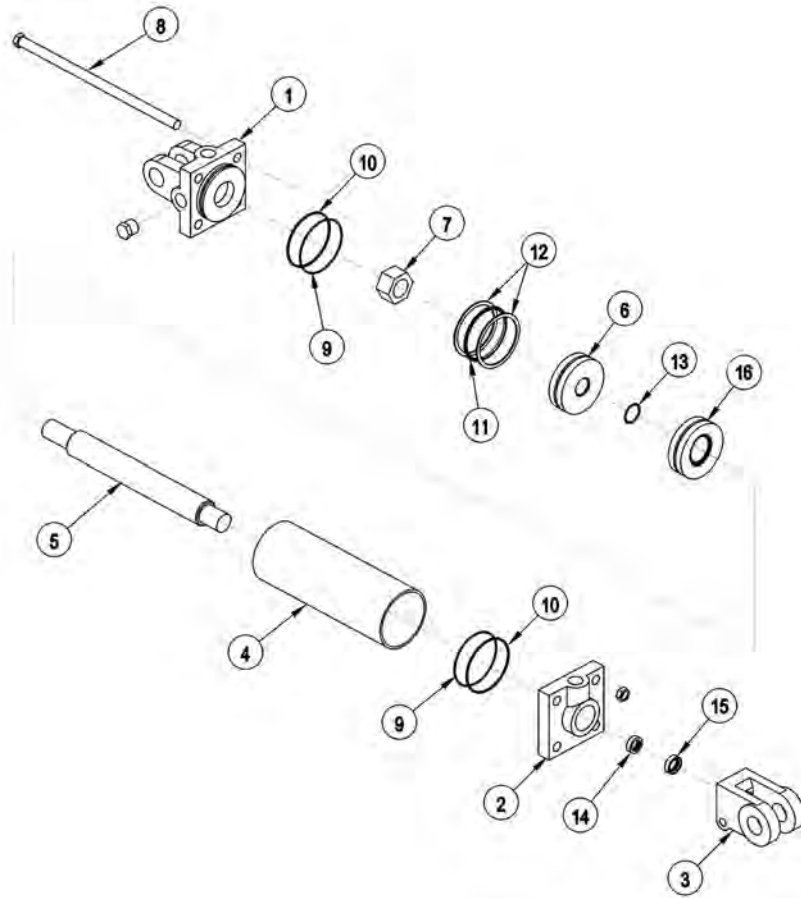

| ITEM | PART NO. | QTY. | DESCRIPTION |
|------|----------|------|-------------------|
| --- | 6T0150 | - | CYLINDER 3" X 18" |
| 1 | 6T0167 | 1 | CYLINDER BUTT |
| 2 | 6T0170 | 1 | CYLINDER GLAND |
| 3 | 6T0178 | 1 | CLEVIS END |
| 4 | 6T0165 | 1 | CYLINDER TUBE |
| 5 | 6T0162 | 1 | PISTON ROD |
| 6 | 6T0173 | 1 | PISTON |
| 7 | 6T0179 | 1 | LOCKNUT |
| 8 | 6T0177 | 4 | TIE ROD ASY |
| --- | 6T0187 | - | SEAL KIT |
| 9 | ----- | 2 | O - RING |
| 10 | ----- | 2 | BACK - UP WASHER |
| 11 | ----- | 1 | O - RING |
| 12 | ----- | 2 | BACK - UP WASHER |
| 13 | ----- | 1 | O - RING |
| 14 | ----- | 1 | U - CUP |
| 15 | ----- | 1 | WIPER |
| 16 | 6T0206 | 1 | SPACER |

COMMON TWIN

RESERVOIR TANK FILTER ASSEMBLY

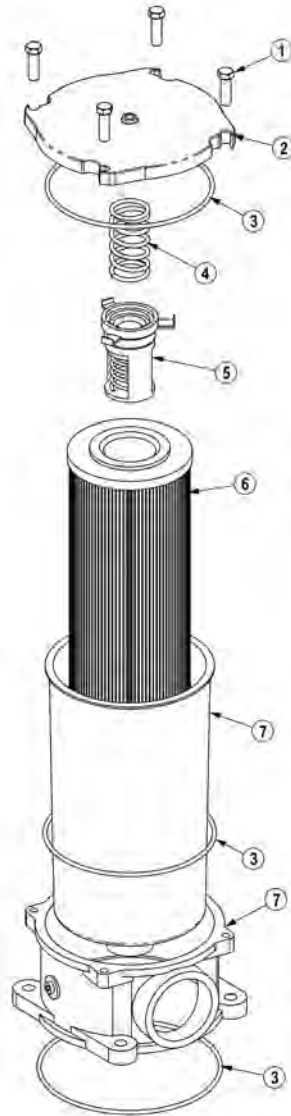

| ITEM | PART NO. | QTY. | DESCRIPTION |
|------|----------|------|-----------------------------------|
| --- | 06505044 | - | FILTER ASSY SAE 10 MICRON |
| 1 | 28583 | 4 | CAPSCREW, 8MM X 25MM (1.25 PITCH) |
| 2 | 06505045 | 1 | COVER |
| 3 | 06505046 | 1 | SEAL KIT |
| 4 | 06505047 | 1 | SPRING |
| 5 | 06505048 | 1 | BYPASS |
| 6 | 35259 | 1 | FILTER, 10 MIC, RETURN LINE |
| 7 | 06505049 | 1 | CAN/BODY |

COMMON TWIN

ROTARY MOTOR BREAKDOWN

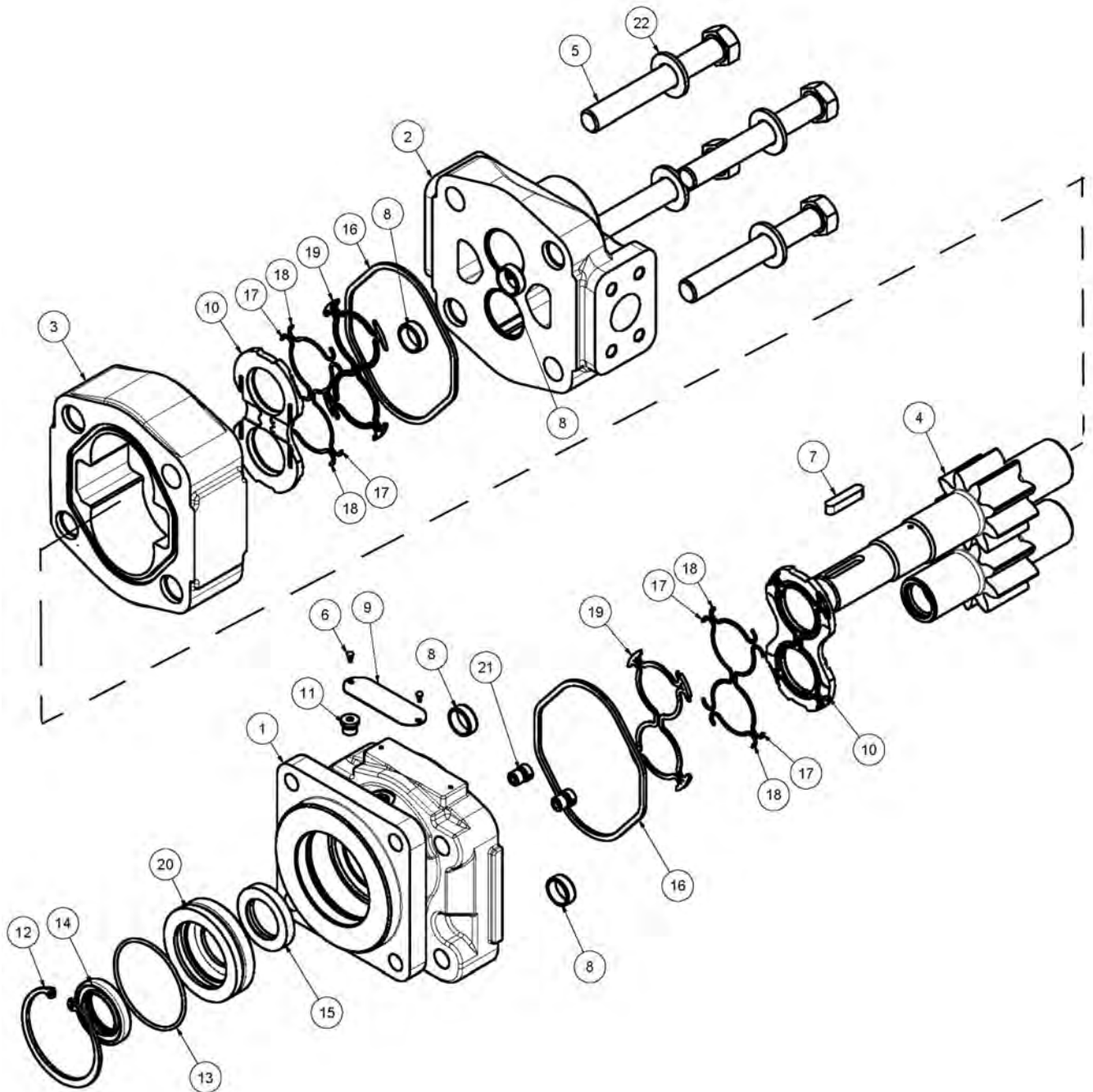

COMMON TWIN

ROTARY MOTOR BREAKDOWN

Continued...

| ITEM | PART NO. | QTY. | DESCRIPTION |
|------|----------|------|-----------------|
| | 06504011 | - | MOTOR ASSEMBLY |
| 1 | 22790 | 1 | END,COVER |
| 2 | 06504088 | 1 | HOUSING, PEC |
| 3 | 06504111 | 1 | HOUSING, GEAR |
| 4 | 06504026 | 1 | SET, GEAR SHAFT |
| 5 | 06504104 | 4 | CAPSCREW |
| 6 | 06504078 | 2 | SCREW, DRIVE |
| 7 | 06504092 | 1 | KEY |
| 8 | 06504093 | 4 | PIN, DOWEL |
| 9 | 06504094 | 1 | NAME PLATE |
| 10 | 06504095 | 2 | THRPL |
| 11 | 2961940 | 1 | PLUG, ODT |
| 12 | 2962200 | 1 | RING, SNAP |
| 13 | 06504096 | 1 | O RING |
| 14 | 6T5101 | 1 | SEAL, LIP |
| 15 | 06504097 | 1 | SEAL, LIP |
| 16 | 22797 | 2 | SEAL, SQ-R |
| 17 | 06504098 | 4 | SEAL, SIDE CHAN |
| 18 | 06504099 | 4 | SEAL, END CHAN |
| 19 | 06504100 | 2 | SEAL, BK-UP |
| 20 | 06504101 | 1 | RTNR, SEAL |
| 21 | 6T5809 | 2 | CHECK ASS'Y |
| 22 | 06504102 | 4 | WASHER |
| --- | 06504103 | - | SEAL KIT |

COMMON TWIN

60IN TSR ROTARY MOTOR BREAKDOWN

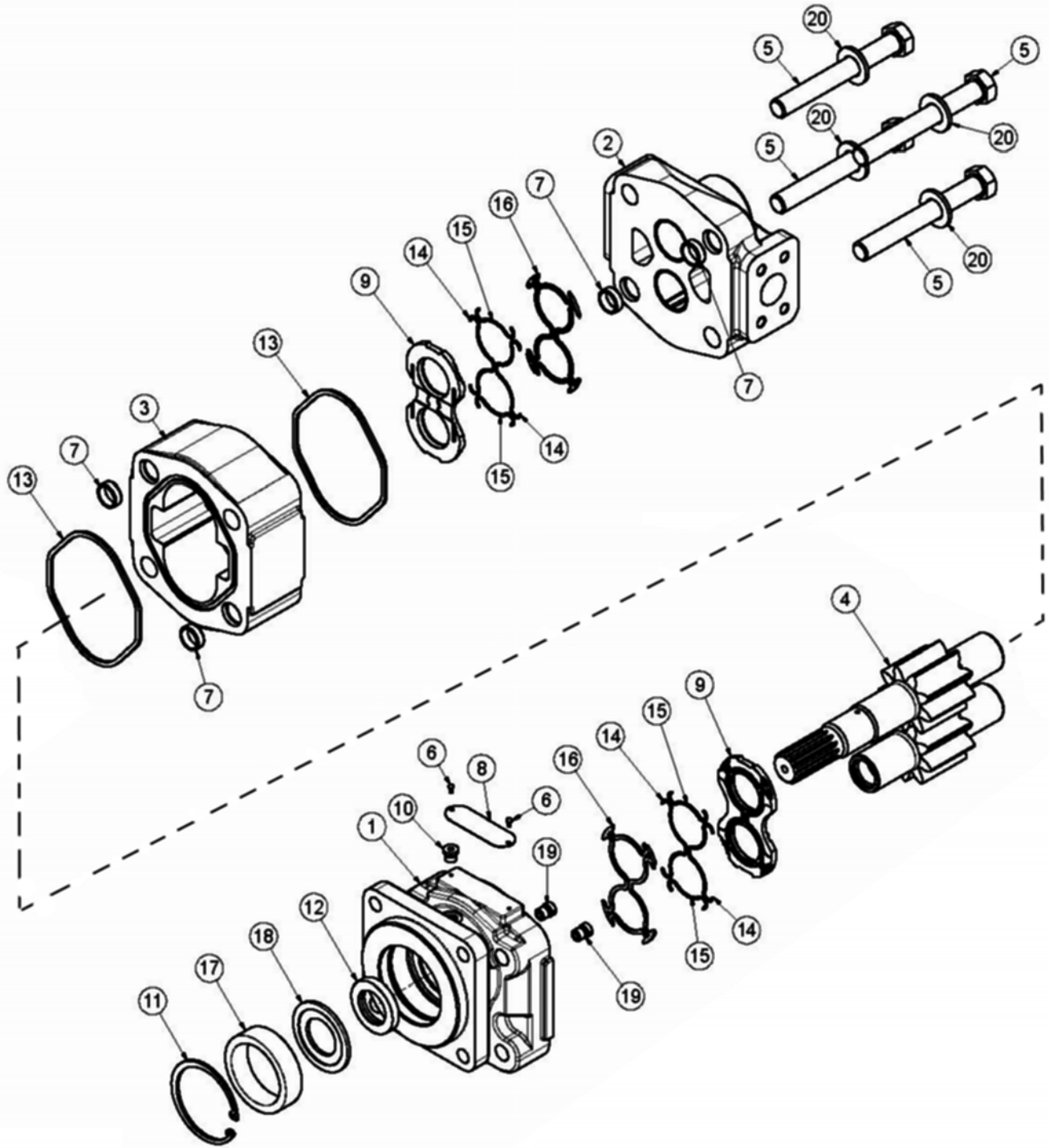

60IN TSR ROTARY MOTOR BREAKDOWN

Continued...

| ITEM | PART NO. | QTY. | DESCRIPTION |
|------|----------|------|--------------------------------|
| | 06504016 | - | MOTOR(M365-1 1/4SPLINE),SEALED |
| 1 | 22790 | 1 | COVER,END |
| 2 | 06504088 | 1 | HOUSING,PEC |
| 3 | 06504111 | 1 | HOUSING,GEAR |
| 4 | 06504110 | 1 | SET,GEAR SHAFT |
| 5 | 06504104 | 4 | CAP SCREW |
| 6 | 06504078 | 2 | SCREW,DRIVE |
| 7 | 06504093 | 4 | PIN,DOWEL |
| 8 | 06504094 | 1 | NAME PLATE |
| 9 | 06504095 | 2 | THRPL |
| 10 | 02961940 | 1 | PLUG,ODT (0.25) |
| 11 | 6T5200 | 1 | RING,SNAP |
| 12 | 06504097 | 1 | SEAL,LIP |
| 13 | 22797 | 2 | SEAL,SQ-R |
| 14 | 06504098 | 4 | SEAL,SIDE CHAN |
| 15 | 06504099 | 4 | SEAL,END CHAN |
| 16 | 06504100 | 2 | SEAL,BK-UP |
| 17 | 06504112 | 1 | SPACER |
| 18 | 06504113 | 1 | RTNR,SEAL |
| 19 | 6T5809 | 2 | CHECK ASS'Y |
| 20 | 06504102 | 4 | WASHER |
| --- | 06504022 | 1 | SEAL KIT |

COMMON TWIN

FRONT HYDRAULIC PUMP BREAKDOWN

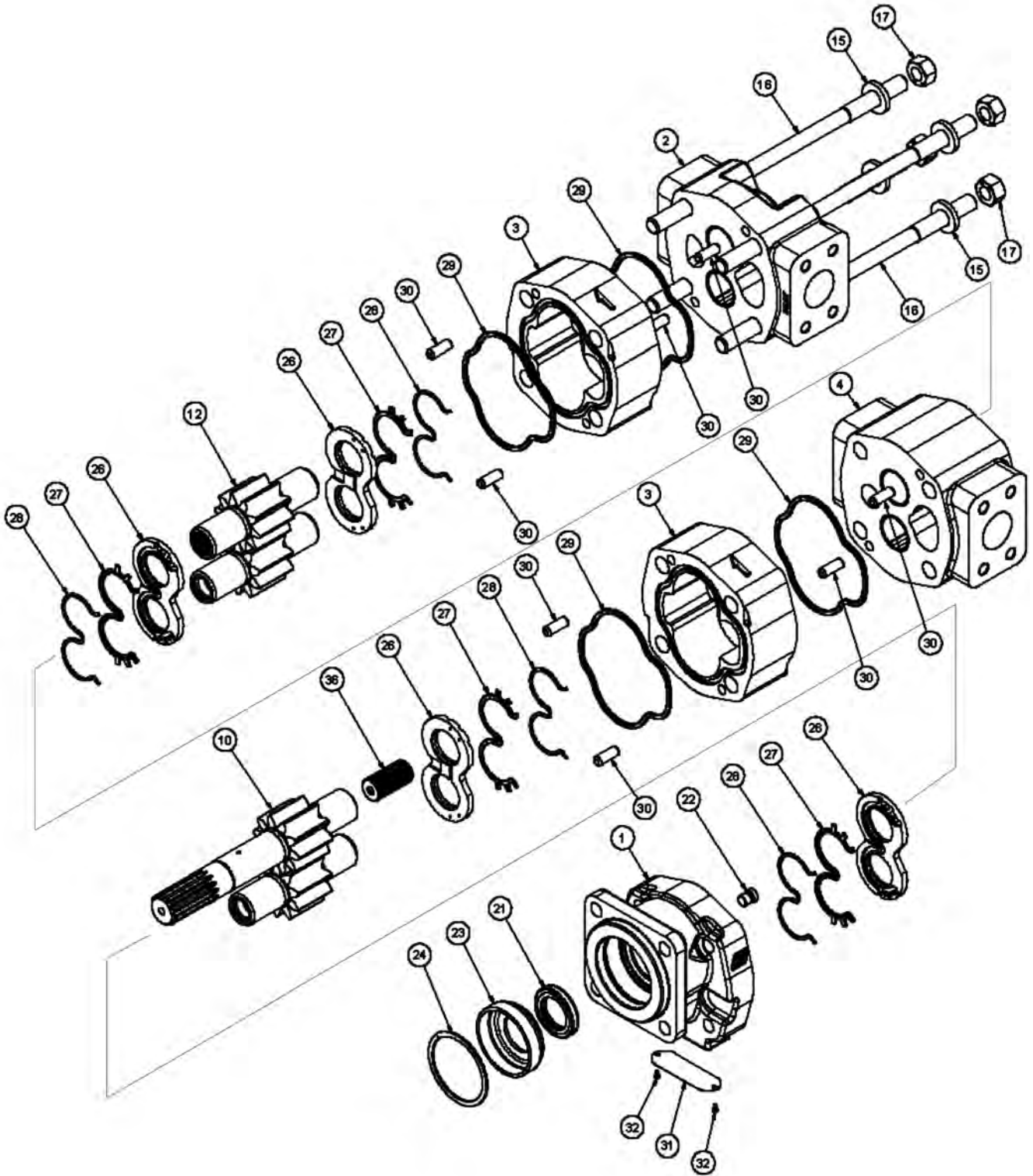

COMMON TWIN

FRONT HYDRAULIC PUMP BREAKDOWN

Continued...

| ITEM | PART NO. | QTY. | DESCRIPTION |
|------|----------|------|----------------------------------|
| --- | 06504002 | 1 | PUMP,ASSY |
| 1 | 22766 | 1 | HOUSING,SEC |
| 2 | 06504068 | 1 | HOUSING,PEC |
| 3 | 02965092 | 2 | HOUSING,GEAR |
| 4 | 06504069 | 1 | HOUSING,BEARING CARRIER |
| 10 | 06504070 | 1 | SET,GEARSHAFT |
| 12 | 06504071 | 1 | GEAR,SET |
| 15 | 02961917 | 4 | WASHER |
| 16 | 06504072 | 4 | STUD |
| 17 | 06504073 | 4 | NUT,HEX |
| 21 | 22765 | 1 | SEAL,LIP |
| 22 | 6T5121 | 1 | PLUG |
| 23 | 02979970 | 1 | SPACER |
| 24 | 02979971 | 1 | RING,SNAP |
| 26 | 02965611 | 4 | THRPL |
| 27 | 06504074 | 4 | SEAL,CHAN |
| 28 | 06504075 | 4 | SEAL,BK-UP |
| 29 | 06504076 | 4 | SEAL,SQ-R |
| 30 | 02961924 | 8 | PIN,DOWEL |
| 31 | 06504077 | 1 | NAMEPLATE |
| 32 | 06504078 | 2 | SCREW,DRIVE |
| 36 | 06504079 | 1 | SFT,CONN |
| --- | 22764 | 1 | SEAL KIT (ITEMS 21, 27, 28 & 29) |

COMMON TWIN

COOLER ASSEMBLY

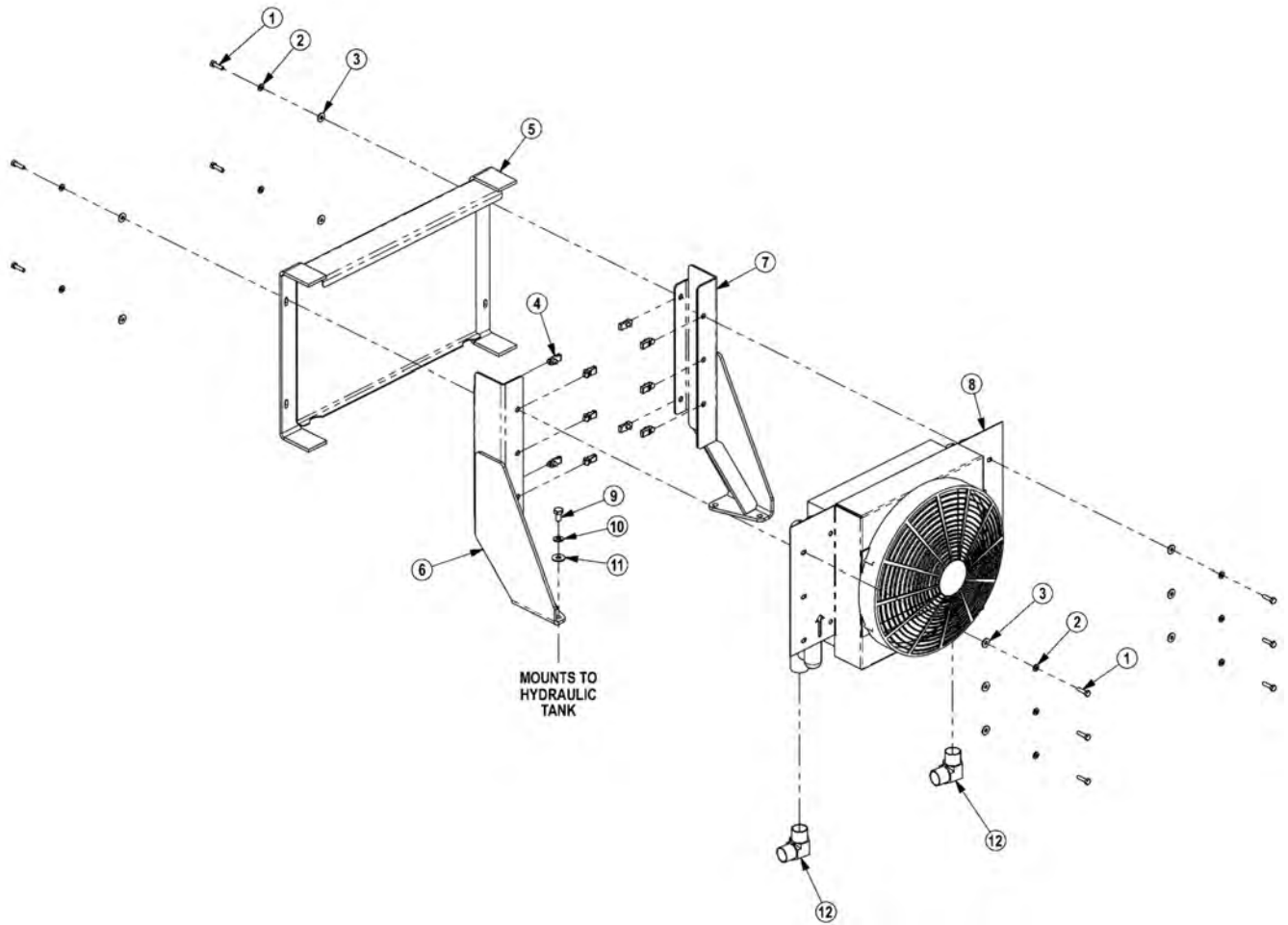

COOLER ASSEMBLY

Continued...

| ITEM | PART NO. | QTY. | DESCRIPTION |
|------|----------|------|---------------------------|
| 1 | 21530 | 10 | CAPSCREW,1/4 X1 NC |
| 2 | 21986 | 10 | LOCKWASHER,1/4 |
| 3 | 22014 | 10 | FLATWASHER,1/4 |
| 4 | 35176 | 10 | 1/4 U-NUT |
| 5 | 06370015 | 1 | SCREEN,COOLER,FRNT |
| 6 | 06380006 | 1 | MNT,COOLER,BUMPER TANK,RH |
| 7 | 06380007 | 1 | MNT,COOLER,BUMPER TANK,LH |
| 8 | 06510026 | 1 | COOLER,FRONT MNT |
| --- | 06510029 | 1 | FAN ASSY ONLY |
| 9 | 21629 | 4 | CAPSCREW,3/8 X 3/4 NC |
| 10 | 21988 | 4 | LOCKWASHER,3/8 |
| 11 | 22016 | 4 | FLATWASHER,3/8 |
| 12 | 34117 | 2 | ELBOW,1MOR X 1MJ90,FORGED |

COMMON TWIN

CABLE (MANUAL) LIFT VALVE BREAKDOWN - 31320

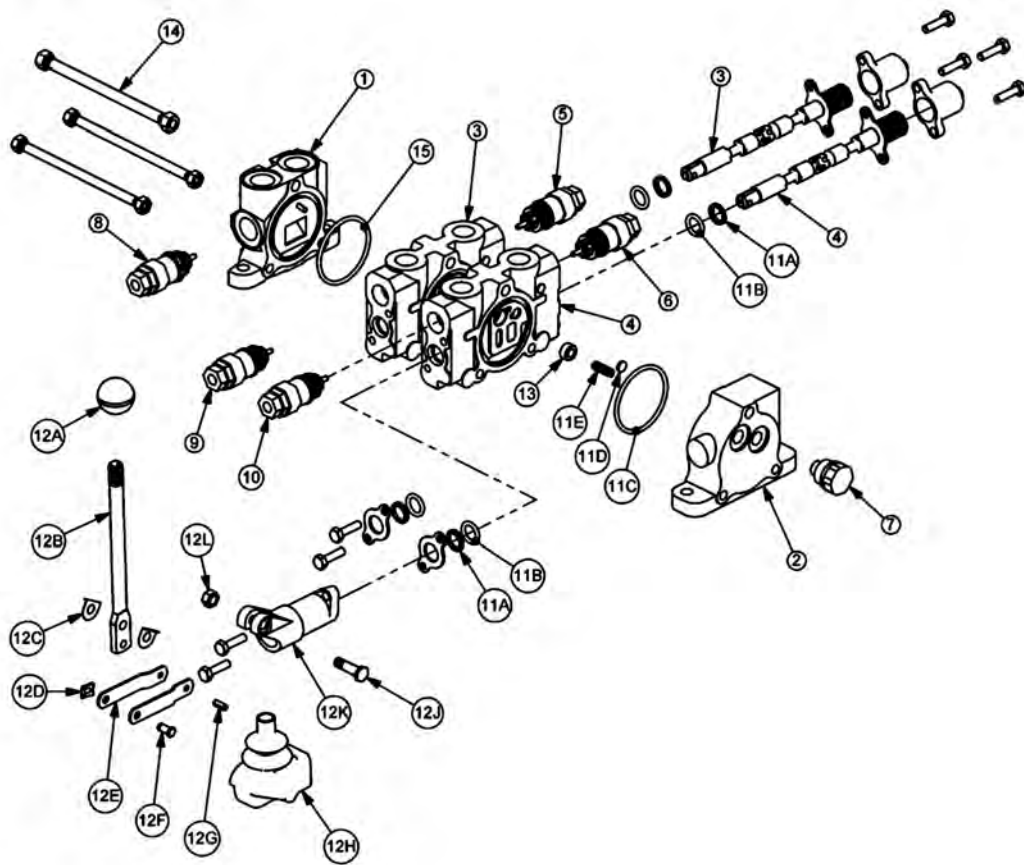

COMMON TWIN

CABLE (MANUAL) LIFT VALVE BREAKDOWN - 31320

Continued...

| ITEM | PART NO. | QTY. | DESCRIPTION |
|------|----------|------|--|
| 1 | 31595 | 1 | INLET END COVER |
| 2 | 31594 | 1 | END COVER, LOAD SENSE |
| 3 | 31597 | 1 | VALVE SECTION (DOUBLE ACTING, CENTER SPRING) |
| 4 | 31597 | 1 | VALVE SECTION (DOUBLE ACTING, CENTER SPRING) |
| 5 | 06503067 | 1 | RELIEF PLUG |
| 6 | 06503067 | 1 | RELIEF PLUG |
| 7 | N/A | - | N/A |
| 8 | 6T4209 | 1 | RELIEF PLUG |
| 9 | 31862 | 1 | RELIEF VALVE, 2175 PSI |
| 10 | 31862 | 1 | RELIEF VALVE, 2175 PSI |
| 11 | 31593 | 2 | VALVE SEAL KIT (FOR ONE SECTION) |
| 11A | ----- | 2 | WIPER |
| 11B | ----- | 2 | O-RING SMALL |
| 11C | ----- | 1 | O-RING LARGE |
| 11D | ----- | 1 | SHUTTLE DISC |
| 11E | ----- | 1 | SPRING |
| 12 | TB1017L | 2 | LEVER KIT (FOR ONE SECTION) |
| 12A | ----- | 1 | LEVER KNOB |
| 12B | ----- | 1 | LEVER |
| 12C | ----- | 2 | LEVER WASHER |
| 12D | ----- | 1 | LEVER CLIP |
| 12E | ----- | 2 | LINKAGE |
| 12F | ----- | 1 | LEVER PIN |
| 12G | ----- | 1 | ROLL PIN |
| 12H | ----- | 1 | LEVER BOOT |
| 12J | ----- | 1 | LEVER BOLT |
| 12K | ----- | 1 | LEVER DUST COVER |
| 12L | ----- | 1 | LEVER NUT |
| 13 | 31603 | 2 | COMPENSATOR |
| 14 | TB1017X | 1 | TIE ROD KIT |
| 15 | 24214 | 1 | O-RING, LARGE |

COMMON TWIN

CABLE (MANUAL) LIFT VALVE BREAKDOWN - 31321

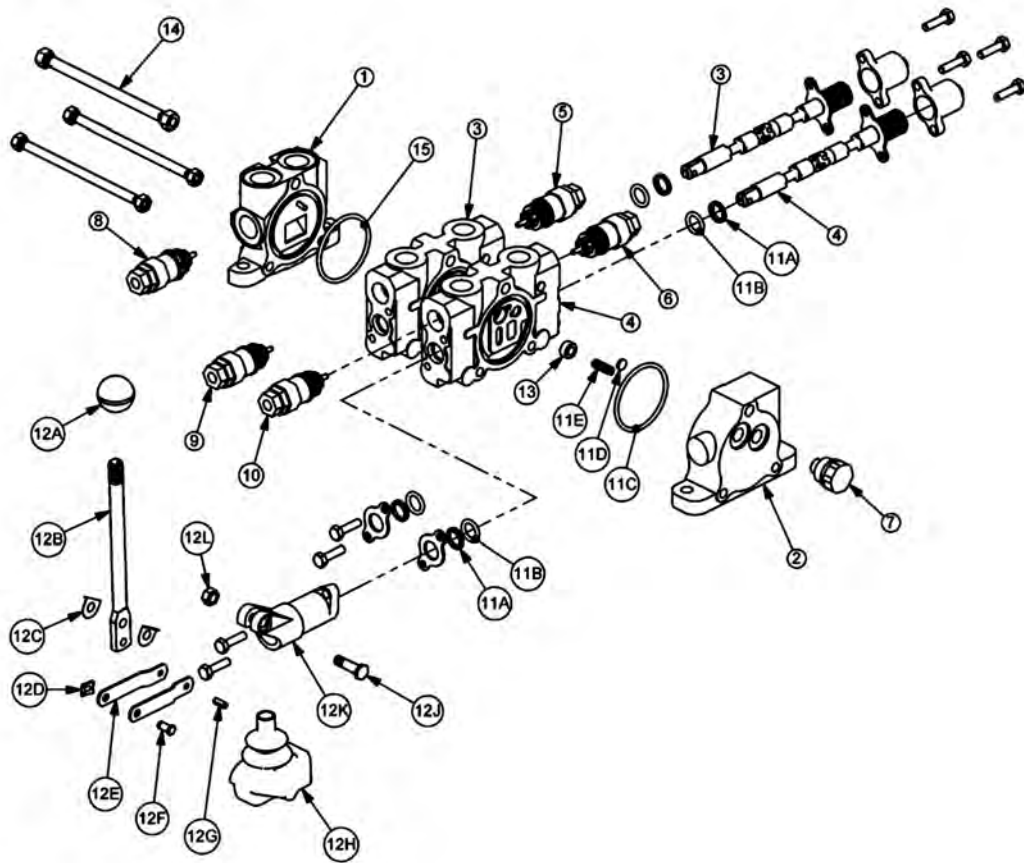

COMMON TWIN

CABLE (MANUAL) LIFT VALVE BREAKDOWN - 31321

Continued...

| ITEM | PART NO. | QTY. | DESCRIPTION |
|------|----------|------|--|
| 1 | 31595 | 1 | INLET END COVER |
| 2 | 31594 | 1 | END COVER, LOAD SENSE |
| 3 | 31597 | 1 | VALVE SECTION (DOUBLE ACTING, CENTER SPRING) |
| 4 | 31597 | 1 | VALVE SECTION (DOUBLE ACTING, CENTER SPRING) |
| 5 | 06503067 | 1 | RELIEF PLUG |
| 6 | 31861 | 1 | RELIEF VALVE, 360 PSI |
| 7 | N/A | - | N/A |
| 8 | 6T4209 | 1 | RELIEF PLUG |
| 9 | 31862 | 1 | RELIEF VALVE, 2175 PSI |
| 10 | 31862 | 1 | RELIEF VALVE, 2175 PSI |
| 11 | 31593 | 2 | VALVE SEAL KIT (FOR ONE SECTION) |
| 11A | ----- | 2 | WIPER |
| 11B | ----- | 2 | O-RING SMALL |
| 11C | ----- | 1 | O-RING LARGE |
| 11D | ----- | 1 | SHUTTLE DISC |
| 11E | ----- | 1 | SPRING |
| 12 | TB1017L | 2 | LEVER KIT (FOR ONE SECTION) |
| 12A | ----- | 1 | LEVER KNOB |
| 12B | ----- | 1 | LEVER |
| 12C | ----- | 2 | LEVER WASHER |
| 12D | ----- | 1 | LEVER CLIP |
| 12E | ----- | 2 | LINKAGE |
| 12F | ----- | 1 | LEVER PIN |
| 12G | ----- | 1 | ROLL PIN |
| 12H | ----- | 1 | LEVER BOOT |
| 12J | ----- | 1 | LEVER BOLT |
| 12K | ----- | 1 | LEVER DUST COVER |
| 12L | ----- | 1 | LEVER NUT |
| 13 | 31603 | 2 | COMPENSATOR |
| 14 | TB1017X | 1 | TIE ROD KIT |
| 15 | 24214 | 1 | O-RING, LARGE |

COMMON TWIN

CABLE (MANUAL) LIFT VALVE BREAKDOWN - 06502043

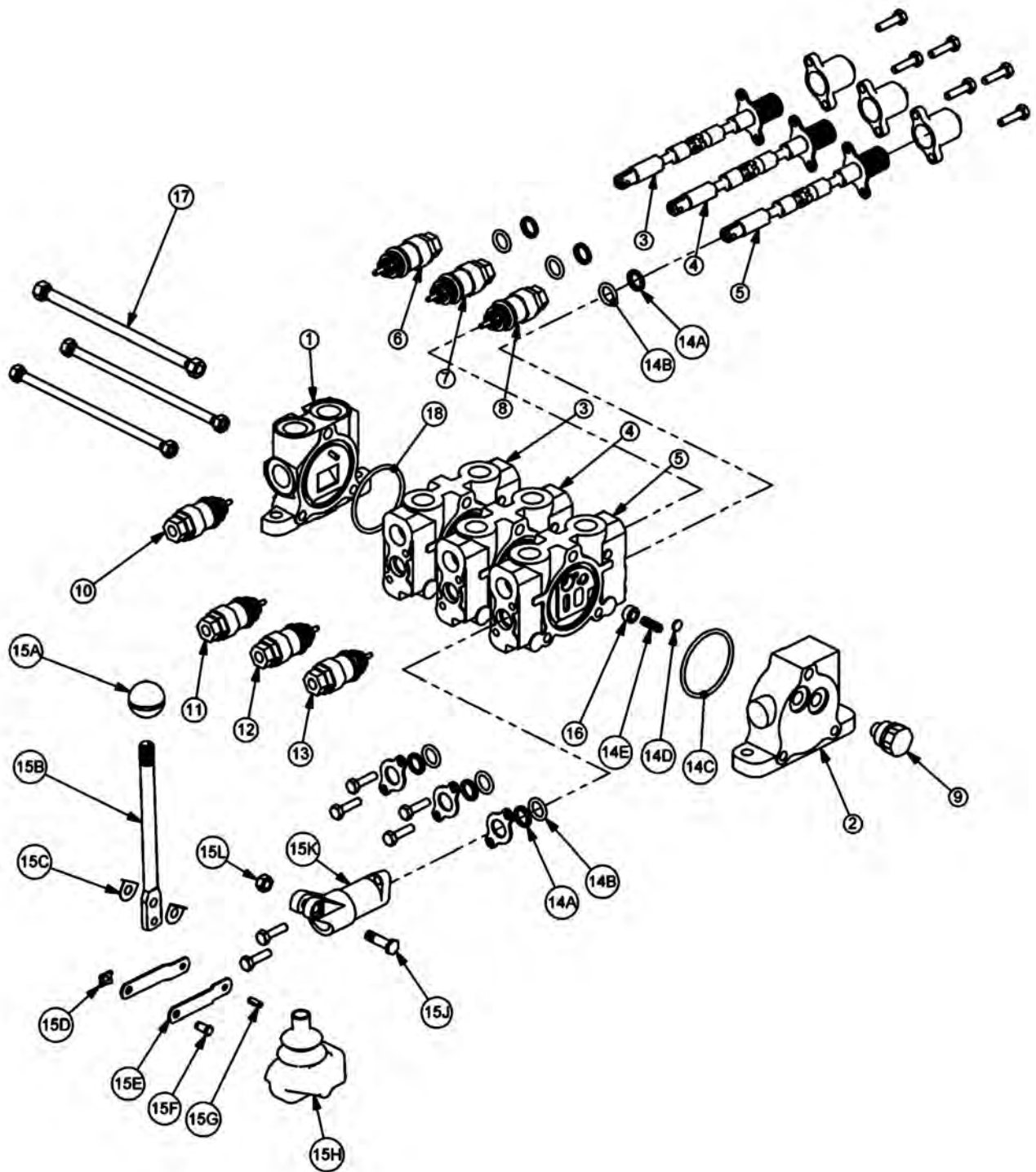

CABLE (MANUAL) LIFT VALVE BREAKDOWN - 06502043

Continued...

| ITEM | PART NO. | QTY. | DESCRIPTION |
|------|----------|------|--|
| 1 | 31595 | 1 | INLET END COVER |
| 2 | 31594 | 1 | END COVER, LOAD SENSE |
| 3 | 31597 | 1 | VALVE SECTION (DOUBLE ACTING, CENTER SPRING) |
| 4 | 31597 | 1 | VALVE SECTION (DOUBLE ACTING, CENTER SPRING) |
| 5 | 31597 | 1 | VALVE SECTION (DOUBLE ACTING, CENTER SPRING) (REMOVE SHUTTLE DISC) |
| 6 | 06503067 | 1 | RELIEF PLUG |
| 7 | 06503067 | 1 | RELIEF PLUG |
| 8 | 28816 | 1 | RELIEF VALVE, 1812 PSI |
| 9 | 06503068 | 1 | RELIEF PLUG |
| 10 | 6T4209 | 1 | RELIEF PLUG |
| 11 | 31862 | 1 | RELIEF VALVE, 2175 PSI |
| 12 | 31862 | 1 | RELIEF VALVE, 2175 PSI |
| 13 | 28816 | 1 | RELIEF VALVE, 1812 PSI |
| 14 | 31593 | 3 | VALVE SEAL KIT (FOR ONE SECTION) |
| 14A | ----- | 2 | WIPER |
| 14B | ----- | 2 | O-RING SMALL |
| 14C | ----- | 1 | O-RING LARGE |
| 14D | ----- | 1 | SHUTTLE DISC |
| 14E | ----- | 1 | SPRING |
| 15 | TB1017L | 3 | LEVER KIT (FOR ONE SECTION) |
| 15A | ----- | 1 | LEVER KNOB |
| 15B | ----- | 1 | LEVER |
| 15C | ----- | 2 | LEVER WASHER |
| 15D | ----- | 1 | LEVER CLIP |
| 15E | ----- | 2 | LINKAGE |
| 15F | ----- | 1 | LEVER PIN |
| 15G | ----- | 1 | ROLL PIN |
| 15H | ----- | 1 | LEVER BOOT |
| 15J | ----- | 1 | LEVER BOLT |
| 15K | ----- | 1 | LEVER DUST COVER |
| 15L | ----- | 1 | LEVER NUT |
| 16 | 31603 | 3 | COMPENSATOR |
| 17 | 23397 | 1 | TIE ROD KIT |
| 18 | 24214 | 1 | O-RING, LARGE |

COMMON TWIN

CABLE (MANUAL) LIFT VALVE BREAKDOWN - 06502044

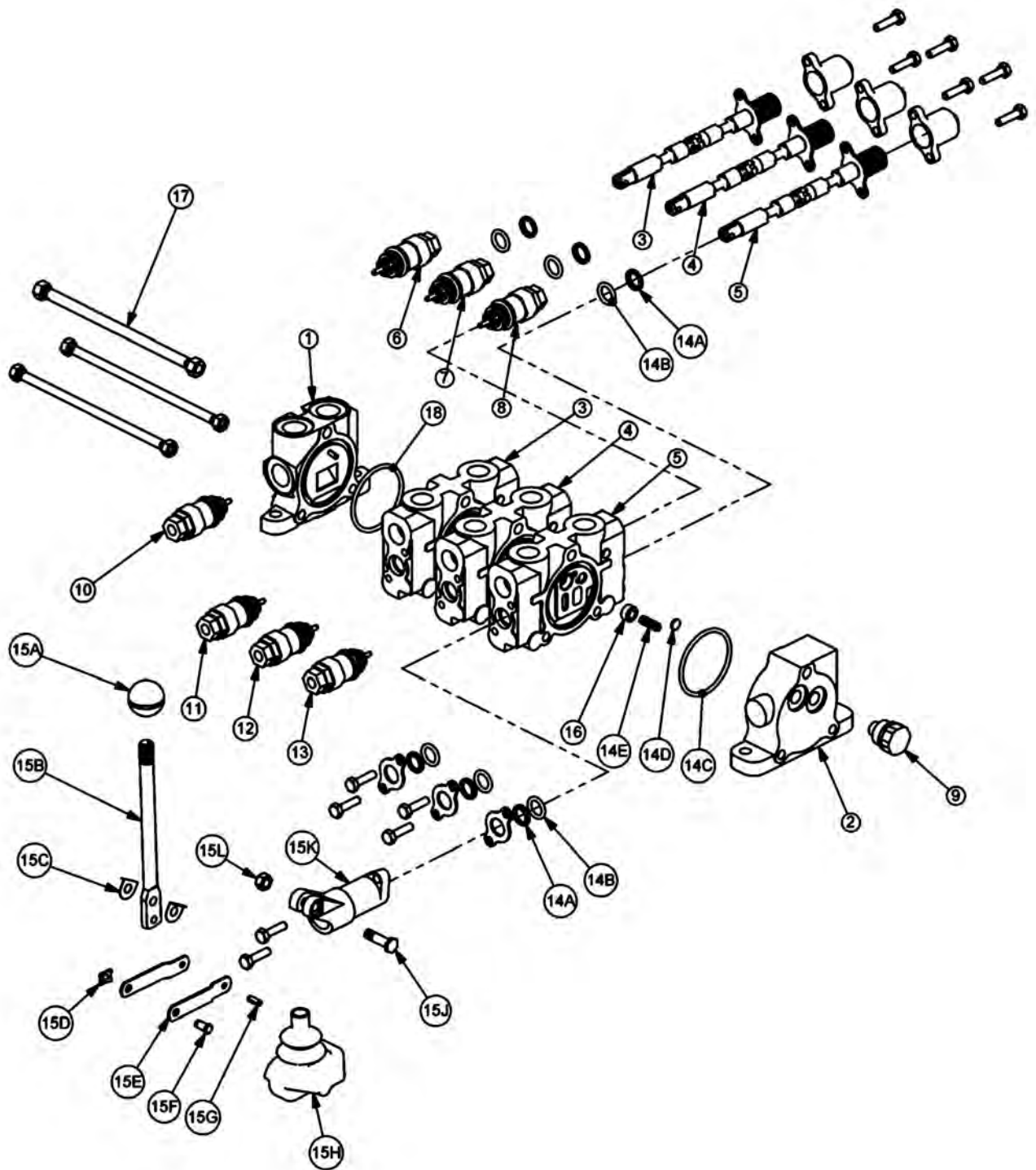

COMMON TWIN

CABLE (MANUAL) LIFT VALVE BREAKDOWN - 06502044

Continued...

| ITEM | PART NO. | QTY. | DESCRIPTION |
|------|----------|------|--|
| 1 | 31595 | 1 | INLET END COVER |
| 2 | 31594 | 1 | END COVER, LOAD SENSE |
| 3 | 31597 | 1 | VALVE SECTION (DOUBLE ACTING, CENTER SPRING) |
| 4 | 31597 | 1 | VALVE SECTION (DOUBLE ACTING, CENTER SPRING) |
| 5 | 31597 | 1 | VALVE SECTION (DOUBLE ACTING, CENTER SPRING) (REMOVE SHUTTLE DISC) |
| 6 | 06503067 | 1 | RELIEF PLUG |
| 7 | 31861 | 1 | RELIEF VALVE, 360 PSI |
| 8 | 28816 | 1 | RELIEF VALVE, 1812 PSI |
| 9 | 06503068 | 1 | RELIEF PLUG |
| 10 | 6T4209 | 1 | RELIEF PLUG |
| 11 | 31862 | 1 | RELIEF VALVE, 2175 PSI |
| 12 | 31862 | 1 | RELIEF VALVE, 2175 PSI |
| 13 | 28816 | 1 | RELIEF VALVE, 1812 PSI |
| 14 | 31593 | 3 | VALVE SEAL KIT (FOR ONE SECTION) |
| 14A | ----- | 2 | WIPER |
| 14B | ----- | 2 | O-RING SMALL |
| 14C | ----- | 1 | O-RING LARGE |
| 14D | ----- | 1 | SHUTTLE DISC |
| 14E | ----- | 1 | SPRING |
| 15 | TB1017L | 3 | LEVER KIT (FOR ONE SECTION) |
| 15A | ----- | 1 | LEVER KNOB |
| 15B | ----- | 1 | LEVER |
| 15C | ----- | 2 | LEVER WASHER |
| 15D | ----- | 1 | LEVER CLIP |
| 15E | ----- | 2 | LINKAGE |
| 15F | ----- | 1 | LEVER PIN |
| 15G | ----- | 1 | ROLL PIN |
| 15H | ----- | 1 | LEVER BOOT |
| 15J | ----- | 1 | LEVER BOLT |
| 15K | ----- | 1 | LEVER DUST COVER |
| 15L | ----- | 1 | LEVER NUT |
| 16 | 31603 | 3 | COMPENSATOR |
| 17 | 23397 | 1 | TIE ROD KIT |
| 18 | 24214 | 1 | O-RING, LARGE |

COMMON TWIN

CABLE (MANUAL) LIFT VALVE BREAKDOWN - 06502087

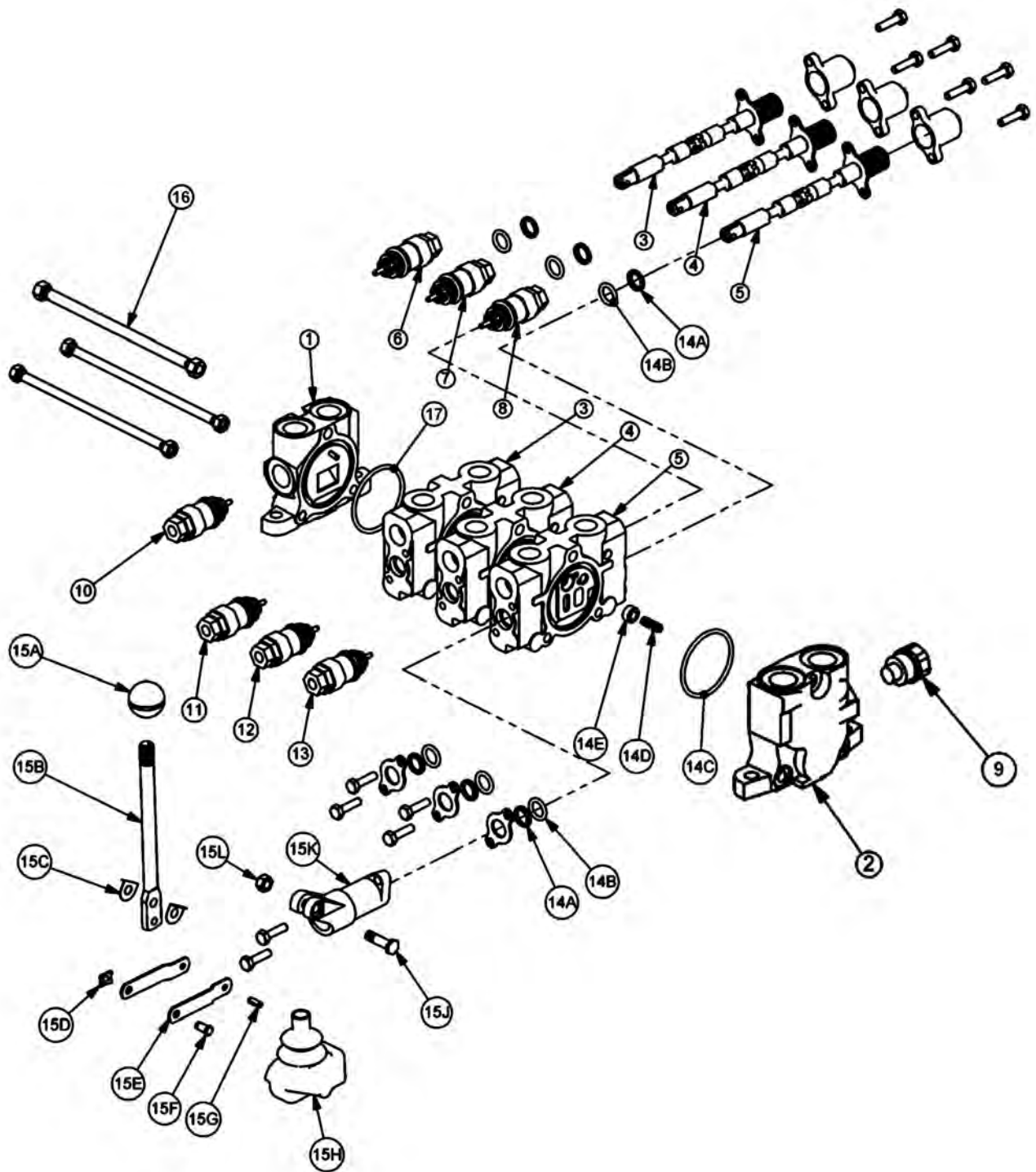

CABLE (MANUAL) LIFT VALVE BREAKDOWN - 06502087

Continued...

| ITEM | PART NO. | QTY. | DESCRIPTION |
|------|----------|------|--|
| 1 | TB1017S | 1 | INLET END COVER |
| 2 | TB1702 | 1 | END COVER, POWER BEYOND |
| 3 | TB1017P | 1 | VALVE SECTION (SINGLE ACTING, SPRING DETENT) |
| 4 | TB1017P | 1 | VALVE SECTION (SINGLE ACTING, SPRING DETENT) |
| 5 | TB1017N | 1 | VALVE SECTION (DOUBLE ACTING, CENTER SPRING) |
| 6 | ----- | - | N/A |
| 7 | ----- | - | N/A |
| 8 | 28816 | 1 | RELIEF VALVE, 1812 PSI |
| 9 | TB1017M | 1 | SHUT-OFF PLUG |
| 10 | 06502085 | 1 | RELIEF VALVE, 3000 PSI |
| 11 | 31862 | 1 | RELIEF VALVE, 2175 PSI |
| 12 | 31862 | 1 | RELIEF VALVE, 2175 PSI |
| 13 | 28816 | 1 | RELIEF VALVE, 1812 PSI |
| 14 | TB1017A | 4 | VALVE SEAL KIT (FOR ONE SECTION) |
| 14A | ----- | 2 | WIPER |
| 14B | ----- | 2 | O-RING SMALL |
| 14C | ----- | 1 | O-RING LARGE |
| 14D | ----- | 1 | SPRING |
| 14E | ----- | 1 | PUCKET |
| 15 | TB1017L | 4 | LEVER KIT (FOR ONE SECTION) |
| 15A | ----- | 1 | LEVER KNOB |
| 15B | ----- | 1 | LEVER |
| 15C | ----- | 2 | LEVER WASHER |
| 15D | ----- | 1 | LEVER CLIP |
| 15E | ----- | 2 | LINKAGE |
| 15F | ----- | 1 | LEVER PIN |
| 15G | ----- | 1 | ROLL PIN |
| 15H | ----- | 1 | LEVER BOOT |
| 15J | ----- | 1 | LEVER BOLT |
| 15K | ----- | 1 | LEVER DUST COVER |
| 15L | ----- | 1 | LEVER NUT |
| 16 | 23397 | 1 | TIE ROD KIT |
| 17 | 24214 | 1 | O-RING, LARGE |

COMMON TWIN

CABLE (MANUAL) LIFT VALVE BREAKDOWN - 06502088

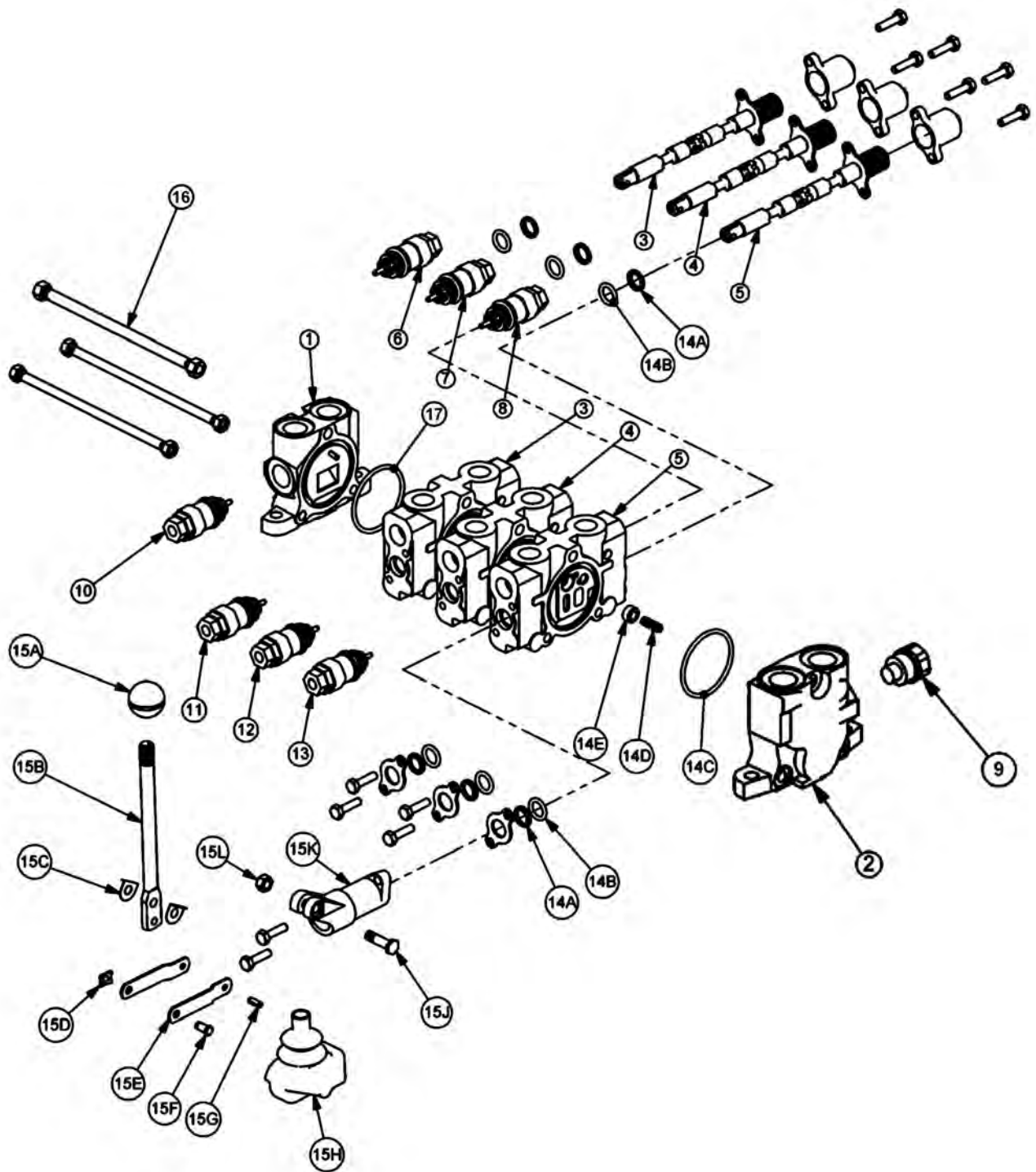

COMMON TWIN

CABLE (MANUAL) LIFT VALVE BREAKDOWN - 06502088

Continued...

| ITEM | PART NO. | QTY. | DESCRIPTION |
|------|----------|------|--|
| 1 | TB1017S | 1 | INLET END COVER |
| 2 | TB1702 | 1 | END COVER, POWER BEYOND |
| 3 | TB1017P | 1 | VALVE SECTION (SINGLE ACTING, SPRING DETENT) |
| 4 | TB1017N | 1 | VALVE SECTION (DOUBLE ACTING, CENTER SPRING) |
| 5 | TB1017N | 1 | VALVE SECTION (DOUBLE ACTING, CENTER SPRING) |
| 6 | ----- | - | N/A |
| 7 | 31861 | 1 | RELIEF VALVE, 360 PSI |
| 8 | 28816 | 1 | RELIEF VALVE, 1812 PSI |
| 9 | TB1017M | 1 | SHUT-OFF PLUG |
| 10 | 06502085 | 1 | RELIEF VALVE, 3000 PSI |
| 11 | 31862 | 1 | RELIEF VALVE, 2175 PSI |
| 12 | 31862 | 1 | RELIEF VALVE, 2175 PSI |
| 13 | 28816 | 1 | RELIEF VALVE, 1812 PSI |
| 14 | TB1017A | 4 | VALVE SEAL KIT (FOR ONE SECTION) |
| 14A | ----- | 2 | WIPER |
| 14B | ----- | 2 | O-RING SMALL |
| 14C | ----- | 1 | O-RING LARGE |
| 14D | ----- | 1 | SPRING |
| 14E | ----- | 1 | PUCKET |
| 15 | TB1017L | 4 | LEVER KIT (FOR ONE SECTION) |
| 15A | ----- | 1 | LEVER KNOB |
| 15B | ----- | 1 | LEVER |
| 15C | ----- | 2 | LEVER WASHER |
| 15D | ----- | 1 | LEVER CLIP |
| 15E | ----- | 2 | LINKAGE |
| 15F | ----- | 1 | LEVER PIN |
| 15G | ----- | 1 | ROLL PIN |
| 15H | ----- | 1 | LEVER BOOT |
| 15J | ----- | 1 | LEVER BOLT |
| 15K | ----- | 1 | LEVER DUST COVER |
| 15L | ----- | 1 | LEVER NUT |
| 16 | 23397 | 1 | TIE ROD KIT |
| 17 | 24214 | 1 | O-RING, LARGE |

COMMON TWIN

BRAKE VALVE ASSEMBLY

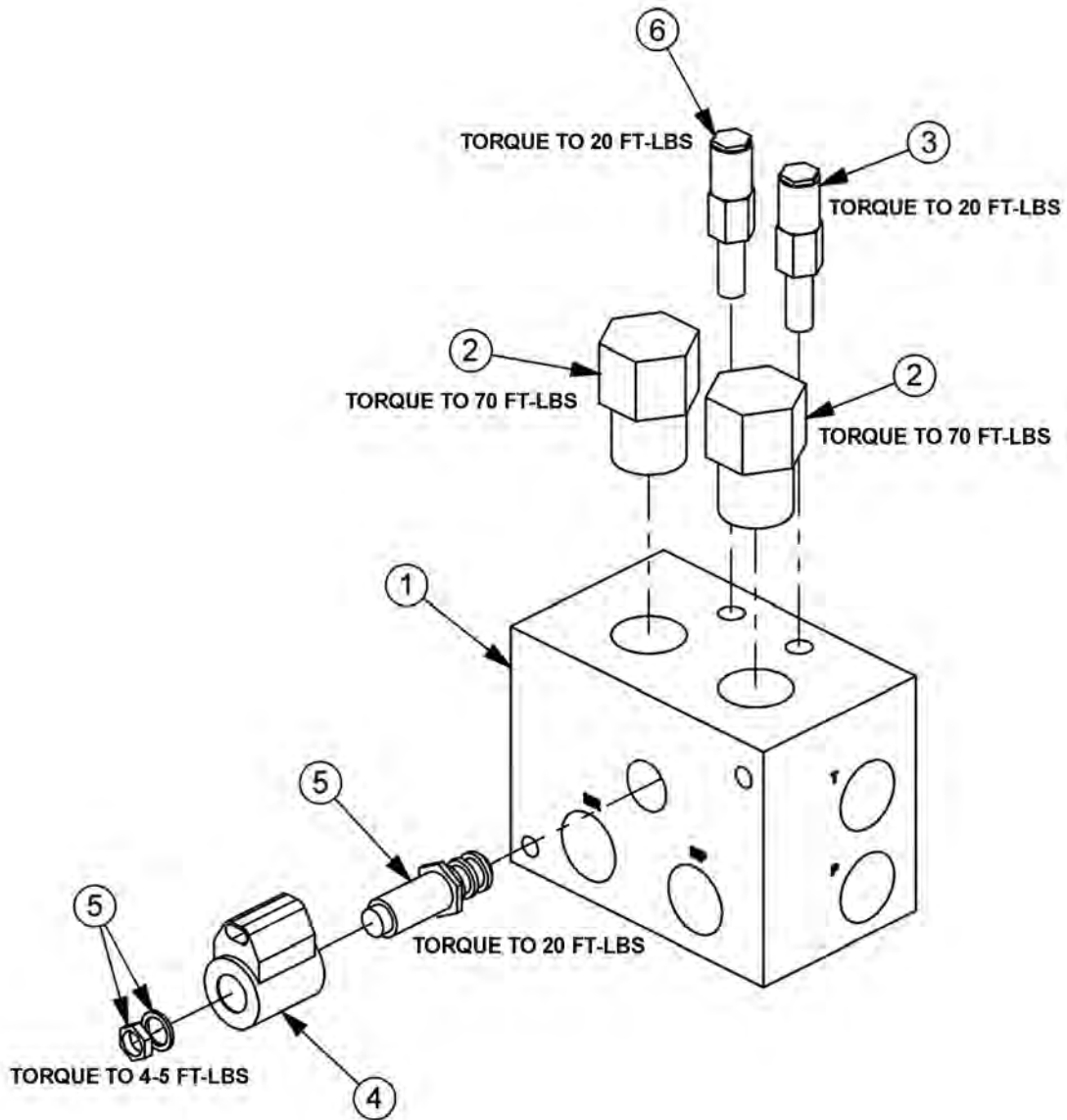

| ITEM | PART NO. | QTY. | DESCRIPTION |
|------|----------|------|--|
| --- | 06510083 | 1 | BRAKE VALVE, ASSY |
| 1 | 34092 | 1 | BRAKE VALVE, BLANK |
| 2 | 34094 | 2 | LOGIC ELEMENT |
| 3 | 34095 | 1 | RELIEF VALVE, 3000 PSI |
| 4 | 06510095 | 1 | METRI PAK COIL |
| 5 | 34093 | 1 | CARTRIDGE, 2 POSITION, 3 WAY (WITH NUT & WASHER) |
| 6 | 34091 | 1 | RELIEF VALVE, 2600 PSI |
| --- | 34096 | 2 | RELIEF SEAL KIT |
| ---- | 34097 | 1 | SOLENOID SEAL KIT |
| --- | 34098 | 2 | ELEMENT SEAL KIT |

COMMON TWIN

BRAKE VALVE HYDRAULIC SCHEMATIC

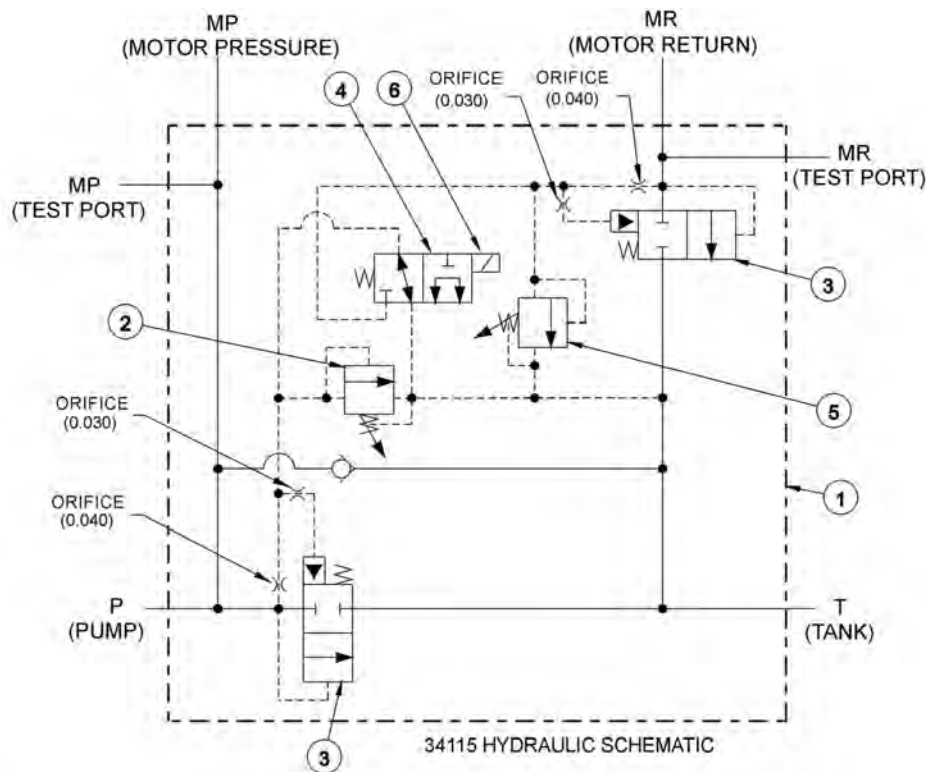

BRAKE VALVE TROUBLESHOOTING

FAILURE MODE:

- MOWER WILL NOT START - system pressure is low (engine not lugging).
- MOWER WILL NOT START - system pressure is high (engine lugging). "MR" port will be high pressure.
- MOWER WILL NOT ROTATE AT FULL SPEED - limited power.
- MOWER BLADE WILL NOT STOP - blade will not stop in proper time.

CHECK STEPS

- 1 thru 6
- 7
- 3 thru 5
- 7 thru 9

CORRECTIVE STEPS:

1. Check for voltage at solenoid (item 6), voltage must be between 10.2 volts and 13.8 volts.
2. Remove, inspect solenoid and cartridge (items 4, 6) for wear or contamination.
3. Remove, inspect logic elements near "P" port (item 3) for wear or contamination.
4. Remove, inspect 3000 psi relief valve (item 2) for wear or contamination.
5. Remove and inspect orifices near "P" port for contamination.
6. Remove "P" port hose and fitting, visually inspect for contamination, check ball for movement.
7. Remove and inspect orifices near "MR" port for contamination.
8. Remove, inspect 2600 psi relief valve (item 5) for wear of contamination.
9. Remove, inspect logic element near "MR" port (item 3) for wear or contamination.

CABLE DRAFT BEAM TRAVEL LOCK

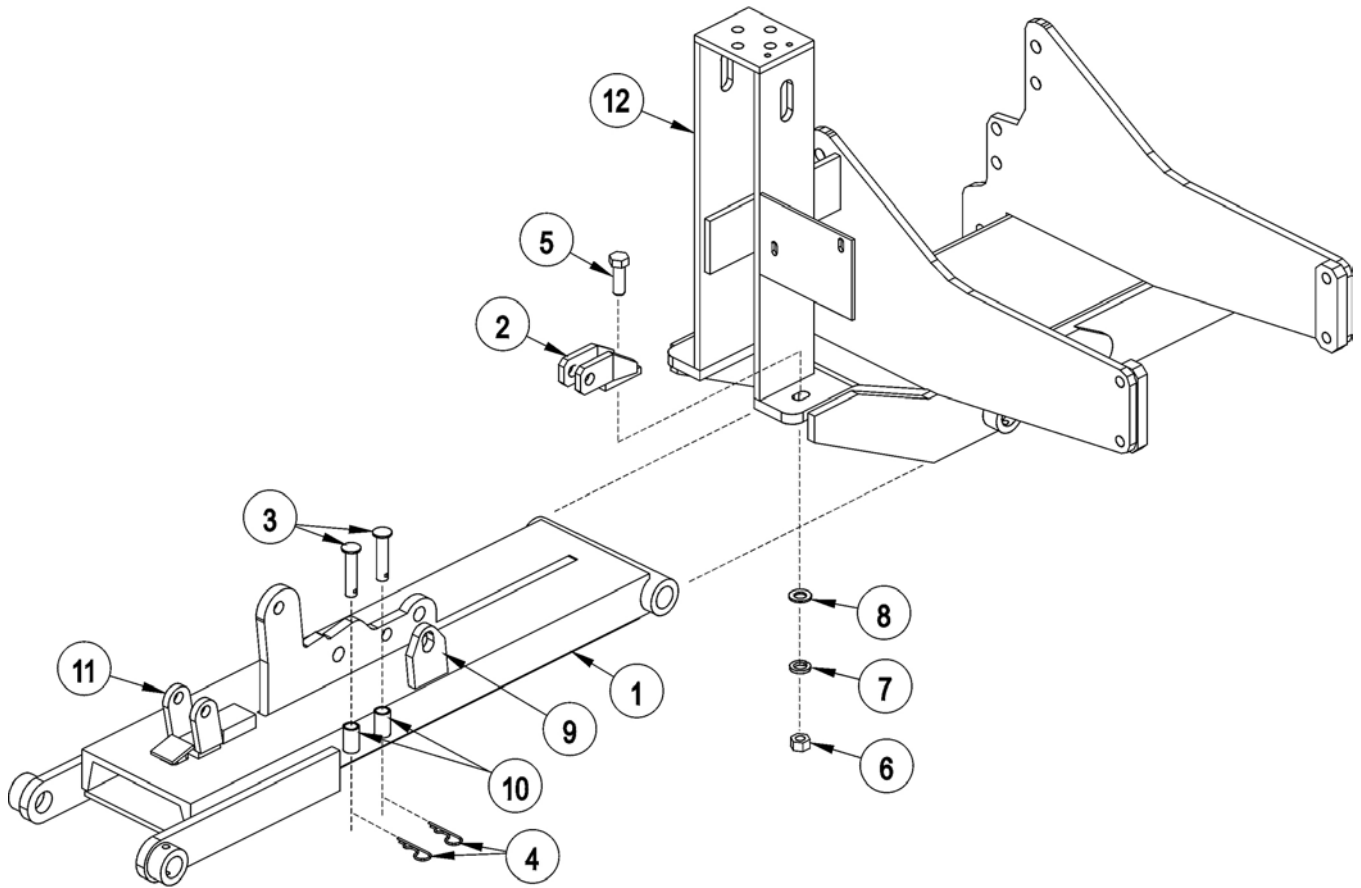

| ITEM | PART NO. | QTY. | DESCRIPTION |
|------|----------|------|------------------------------------|
| 1 | ----- | - | CABLE DRAFT BEAM |
| 2 | 6T0106 | 1 | TRAVEL LOCK BRACKET |
| 3 | 6T0107 | 2 | TRAVEL LOCK PINS 3/4" X 3 1/4" |
| 4 | 6T3020 | 2 | R - CLIP 5/32" |
| 5 | 21833 | 1 | CAPSCREW 3/4" X 2 1/4" |
| 6 | 21825 | 1 | HEX NUT 3/4" |
| 7 | 21993 | 1 | LOCK WASHER 3/4" |
| 8 | 22021 | 1 | FLAT WASHER 3/4" |
| 9 | 22600 | 1 | TRAVEL LOCK EAR |
| 10 | 22604 | 2 | PIN HOLDER |
| 11 | 22601C | 1 | TRAVEL LOCK ASY |
| 12 | ----- | - | MAIN FRAME *REFER TO PARTS SECTION |

COMMON TWIN

COMBO DRAFT BEAM TRAVEL LOCK

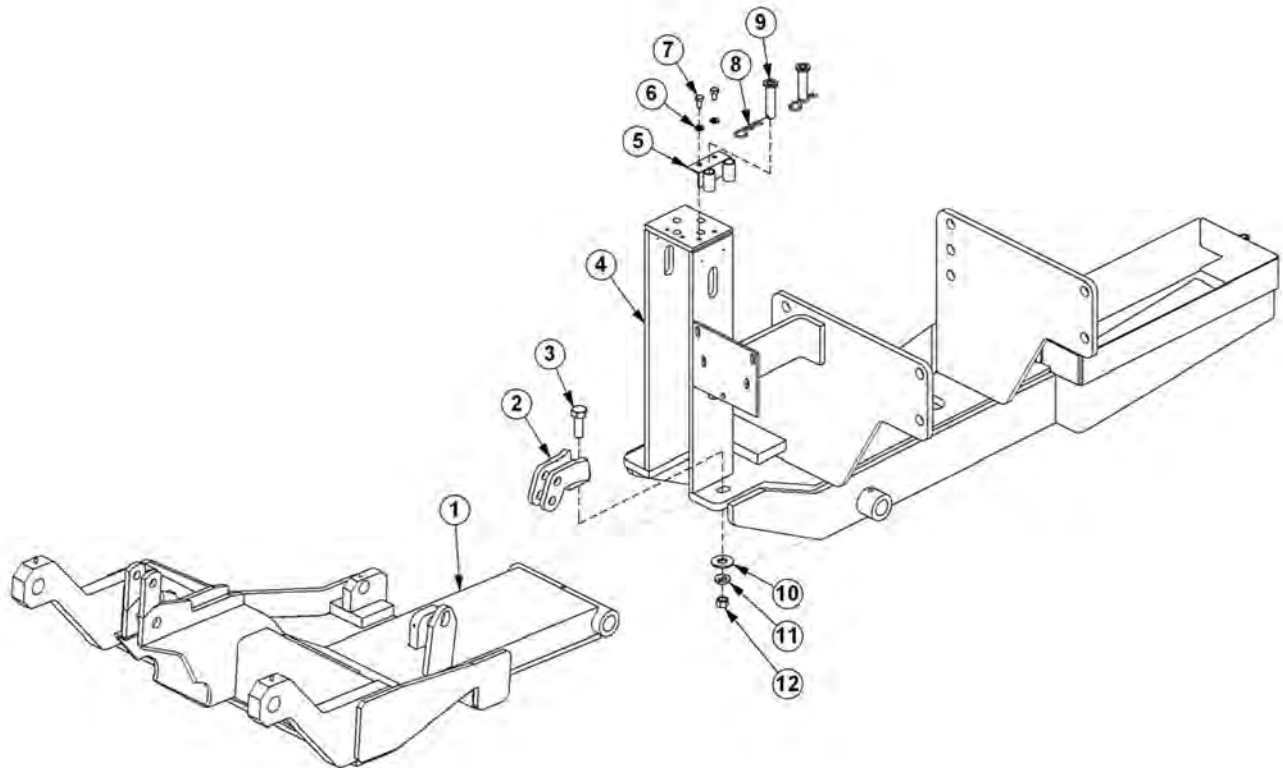

| ITEM | PART NO. | QTY. | DESCRIPTION |
|------|----------|------|------------------------------------|
| 1 | ----- | - | COMBO DRAFT BEAM |
| 2 | 6T0106 | 1 | TRAVEL LOCK BRACKET |
| 3 | 21833 | 1 | CAPSCREW 3/4" X 2 1/4" |
| 4 | ----- | - | MAIN FRAME *REFER TO PARTS SECTION |
| 5 | 33856 | 1 | BRKT,PIN HOLDER |
| 6 | 21988 | 2 | LOCK WASHER 3/8" |
| 7 | 21629 | 2 | CAPSCREW 3/8" X 3/4" |
| 8 | 6T3020 | 2 | R - CLIP 5/32" |
| 9 | 6T0107 | 2 | TRAVEL LOCK PINS 3/4" X 3 1/4" |
| 10 | 22021 | 1 | FLAT WASHER 3/4" |
| 11 | 21993 | 1 | LOCK WASHER 3/4" |
| 12 | 21825 | 1 | HEX NUT 3/4" |

COMMON TWIN

SWITCH BOX

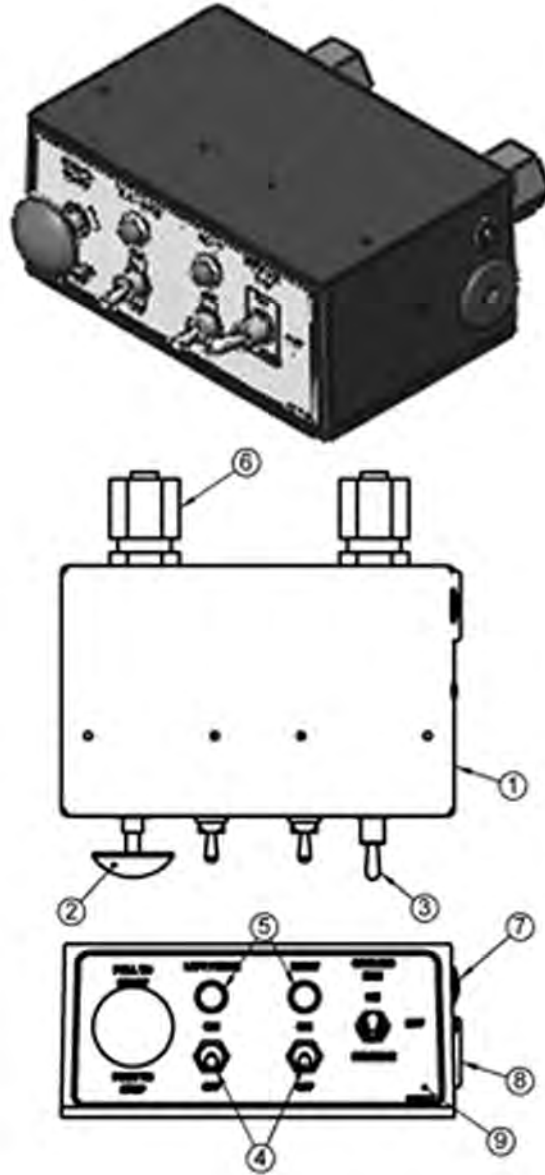

| ITEM | PART NO. | QTY. | DESCRIPTION |
|------|----------|------|--------------------------------|
| 1 | 06514011 | 1 | SWBX,ALUM,BLK,06510097 |
| 2 | 35226 | 1 | SWITCH,MOWER,COLEHERSEE |
| 3 | 06510028 | 1 | SWITCH,FORWARD/BRAKE/REV |
| 4 | 33811 | 2 | SWITCH,MASTER/DECK FLOAT |
| 5 | 6T3923 | 2 | INDICTATOR LIGHT,ON,RED |
| 6 | 34540 | 2 | STRAIN RELIEF,3/4,BLACK,NYLON |
| 7 | 06514006 | 1 | BREAKER,15A,SWBX |
| 8 | 06514015 | 1 | ALARM,SWBX,REVERSER |
| 9 | 06550002 | 1 | DECAL,SWTCHBX,TWIN/T3F,REV FAN |
| 10 | 35227 | 1 | RELAY,DP,DT,12V,LY2F,35226 |

COMMON TWIN

SWITCH BOX SCHEMATIC

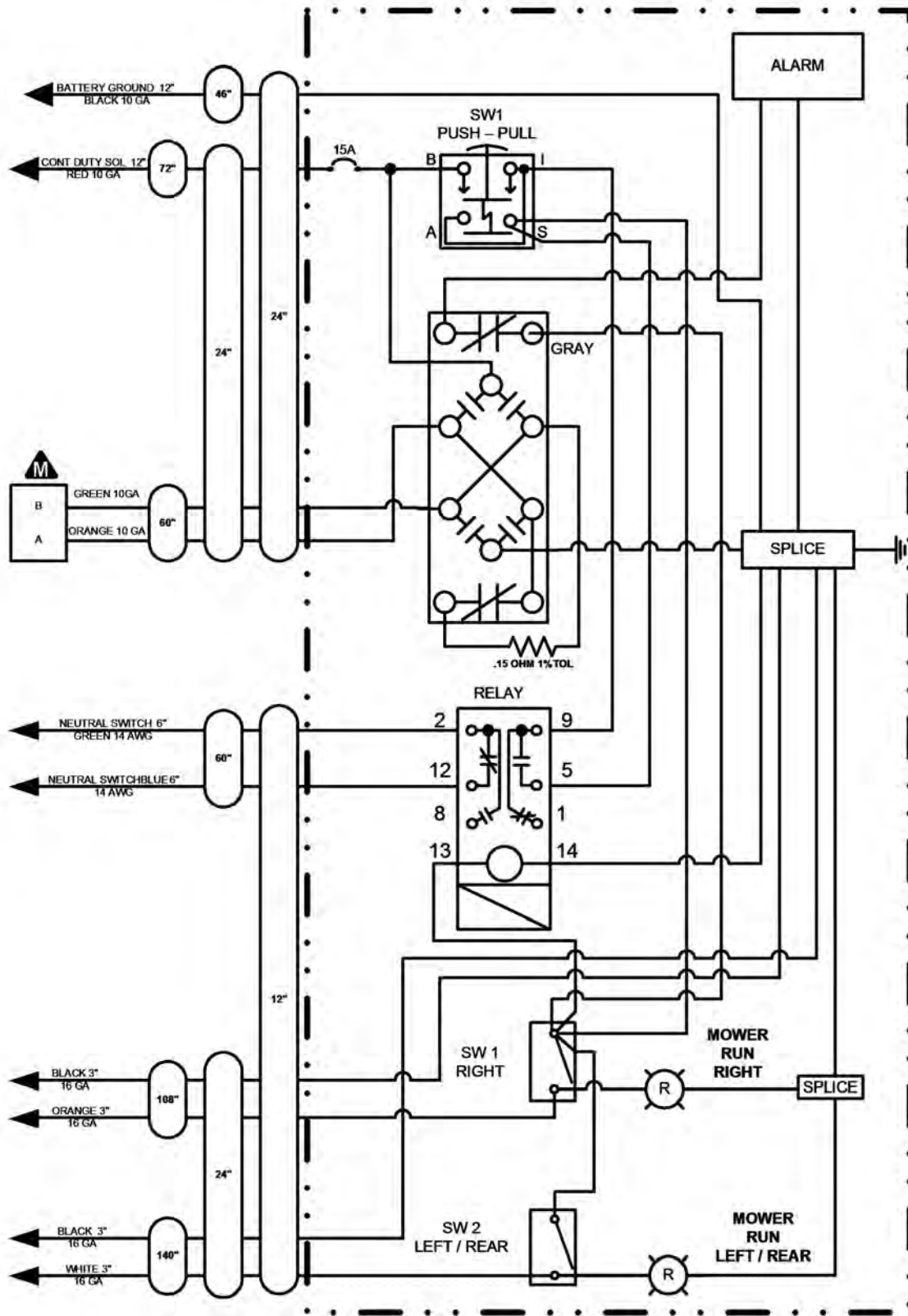

NOTES

WARRANTY SECTION

WARRANTY INFORMATION

Tiger Corporation, 3301 N. Louise, Sioux Falls, South Dakota, warrants to the original Retail Customer, the new Tiger equipment is free of defects in material and workmanship. Any part of equipment that in Tiger's judgement, show evidence of such defects will be repaired or replaced without charge, provided that the failure of part(s) shall have occurred within twelve (12) months from the date of delivery of said equipment to the Retail Customer. Expendable components such as knives, oil, chain sprockets, skid shoes, knife mounting disks and the like are excluded but not limited to this warranty.

The Retail Customer must pay the transportation cost to and from the Tiger Dealer's service shop for warranty service. Warranty service will be performed by the Tiger Dealer from whom the equipment was purchased, during service shop regularly scheduled days and hours of operation.

All Tiger obligation under this warranty shall be terminated if the equipment is modified or altered in ways not approved in writing by Tiger, if repair parts other than genuine Tiger repair parts have been used, or if the equipment has been subject to misuse, neglect, accident, improper maintenance or improper operation.

Tiger Corporation reserves the right to make improvements in design or changes in specification at any time without incurring any obligation to owners of equipment previously sold.

No agent or person has authority to alter, add to or waive the above warranties which are agreed to be in the only warranties, representations or promises, expressed or implied, as to the quality or performance of the products covered and which do not include any implied warranty of merchantability or fitness. In no event will Tiger be liable for incidental or consequential damages or injuries, including, but not limited to, loss of profits, rental or substitute equipment or other commercial loss.

**THERE ARE NO WARRANTIES WHICH EXTEND
BEYOND THOSE EXPRESSED HEREIN.**

It is the Purchasers obligation to sign the warranty registration form **AFTER** he / she has Read and Understands the Operation and Safety Instructions stated within this manual.

ONE LAST WORD

This manual cannot possibly cover all of the potentially hazardous situations you will encounter. By being familiar with the safety rules, operating and maintenance instructions in this manual you can help prevent accidents. The objective of this manual is to help make you a better operator. Remember, **SAFETY IS YOU!**



1012

Your safety and the safety of those around you depends on **YOU**. Common sense should play a large role in the operation of this machine.

Since we at Tiger Corporation are constantly striving to improve our products, we reserve the right to change specifications or design at any time.

TO THE OWNER / OPERATOR / DEALER



To keep your implement running efficiently and safely, read your manual thoroughly and follow these directions and the Safety Messages in this manual and on the machine. The table of contents clearly identifies each section where you can easily find the information you need.

The Occupational Safety and Health Act (OSHA 1928.51 subpart C) makes the following minimum requirements for tractor operators.

OWNER REQUIREMENTS:

1. Provide a Roll-Over-Protective Structure that meets the requirements of this Standard; and
2. Provide Seatbelts that meet the requirements of this Standard and SAE J3C; and
3. Ensure that each employee uses such Seatbelt while the tractor is moving; and
4. Ensure that each employee tightens the Seatbelt sufficiently to confine the employee to the protected area provided by the ROPS.

OPERATOR REQUIREMENTS:

1. Securely fasten seatbelt if the tractor has a ROPS.
2. Where possible, avoid operating the tractor near steep ditches, embankments, and holes.
3. Reduce speed when turning, crossing slopes, and on rough, slick, or muddy surfaces.
4. Stay off slopes too steep for safe operation.
5. Watch where you are going – especially at row ends, on roads, and around trees.
6. Do Not permit others to ride.
7. Operate the tractor smoothly – no jerky turns, starts, or stops.
8. Hitch only to the draw-bar and hitch points recommended by the tractor manufacturer.
9. When the tractor is stopped, set brakes securely and use park lock, if available



Printed in USA
© Tiger Corporation