

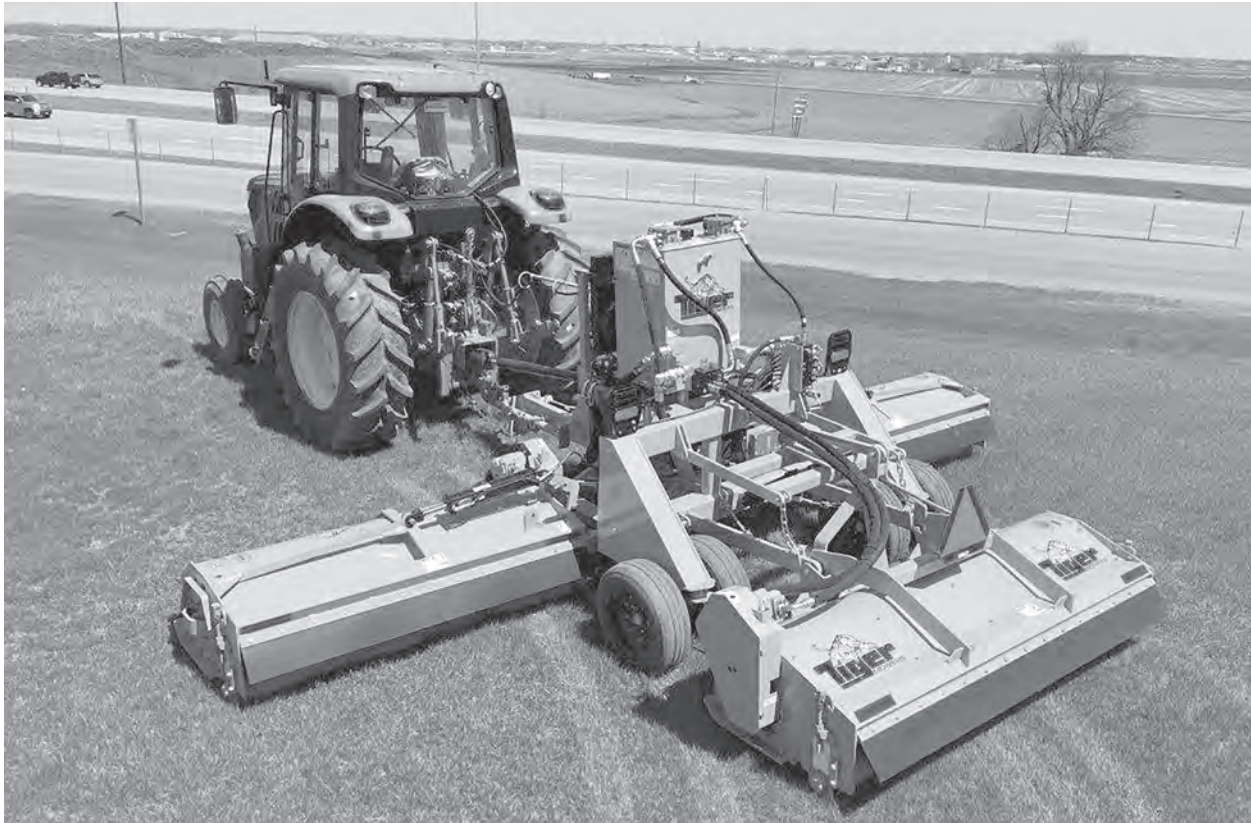

# TIGER TRIPLE THREAT PULL BEHIND MOWER

Current as of 3/28/2019

---



## PARTS LISTING WITH MOUNTING AND OPERATING INSTRUCTIONS

---

**Tiger Corporation**  
3301 N. Louise Ave.  
Sioux Falls, SD 57107  
1-800-843-6849  
1-605-336-7900  
[www.tigermowers.com](http://www.tigermowers.com)

**06090015**

# TO THE OWNER / OPERATOR / DEALER

All implements with moving parts are potentially hazardous. There is no substitute for a cautious, safe-minded operator who recognizes the potential hazards and follows reasonable safety practices. The manufacturer has designed this implement to be used with all its safety equipment properly attached to minimize the chance of accidents.





**BEFORE YOU START!!** Read the safety messages on the implement and shown in this manual. Observe the rules of safety and use common sense!

**READ AND UNDERSTAND THIS MANUAL! Non-English speaking operators will need to GET THE MANUAL TRANSLATED as needed!**



# DANGER

**FAILING TO FOLLOW SAFETY MESSAGES AND OPERATING INSTRUCTIONS CAN CAUSE SERIOUS BODILY INJURY OR EVEN DEATH TO OPERATOR AND OTHERS IN THE AREA.**

<p>1.</p> 	<p>2. NO RIDERS. NO CHILDREN OPERATORS.</p> 	<p>3. USE SAFETY SHOES, HARD HAT, SAFETY GLASSES, SEAT BELTS, ROPS &amp; OPS</p> 	<p>4. BLOCK UP SECURELY BEFORE WORKING UNDER.</p> 
---	---	---	---

1. Study and understand Operator's Manuals, Safety Decals, and Instructional Decals for tractor and implement to prevent misuse, abuse, and accidents. Practice before operating in a confined area or near passersby.  
 ● Learn how to stop engine suddenly in an emergency. Be alert for passersby and especially children

2. Allow no children on or near folding mower or tractor. Allow no riders on tractor or implement. Falling off may cause serious injury or death from being run over by tractor or mower or contact with rotating blades.

3. Operate only with tractor having Roll-Over Protective Structure (ROPS) and with seat belt securely fastened to prevent injury and possible death from falling off or tractor overturn.  
 ● Personal Protective Equipment such as Hard Hat, Safety Glasses, Safety Shoes, & Ear Plugs are recommended.



4. Block up or support raised machine and all lifted components securely before putting hands or feet under or working underneath any lifted component to prevent crushing injury or death from sudden dropping or inadvertent operation of controls. Make certain area is clear before lowering or folding

5. Before transporting, put Lift Lever in detent or full-lift position. Install Transport Safety Devices securely on folding mowers. Put Booms securely in Transport Rest.  
 ● Folding and Boom Mowers have raised center of gravity. Slow down when turning and on hillsides.

6. Make certain that SMV sign, warning lights, and reflectors are clearly visible. Follow local traffic codes.

7. Never operate with Cutting Head or Folding Section raised if passersby, bystanders, or traffic are in the area to reduce possibility of injury or death from objects thrown by Blades under Guards or mower structure.

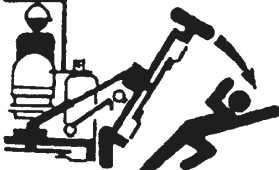
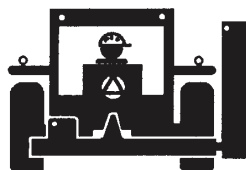
8. Before dismounting, secure implement in transport position or lower to ground.  
 ● Put tractor in park or set brake, disengage PTO, stop engine, remove key, and wait until noise of rotation has ceased to prevent crushing by entanglement in rotating parts which could cause injury or death.  
 ● Never mount or dismount a moving vehicle. Crushing from runover may cause serious injury or death.

<p>5. TRANSPORT SAFELY, LOCK UP.</p> 	<p>6. USE SMV, LIGHTS, &amp; REFLECTORS.</p> 	<p>7. DO NOT OPERATE WITH CUTTER OR WING RAISED.</p> 	<p>8. DO NOT MOUNT OR DISMOUNT WHILE MOVING.</p> 
--	--	---	--

Warranty Information: Read and understand the complete Warranty Statement found in this manual. Fill out the Warranty Registration form in full and return it within 90 days. Make certain the Serial Number of the machine is recorded on the Warranty Card, and form that you retain.

# FORWARD

This manual contains information about many features of the Tiger mowing and roadside maintenance equipment. Some of these include: Safety precautions, Assembly instructions, Operations, Maintenance and Parts. This manual will also assist you in the proper break-in, daily care, and troubleshooting of your new mower.

We recommend that you read carefully the entire manual before operating the unit. Also, time spent in becoming fully acquainted with its performance features, adjustments, and maintenance schedules will be repaid in a long and satisfactory life of the equipment.

## **Troubleshooting - Please, before you call, help us to help you!**

Please look at the equipment to observe what is happening, then:

- Classify the problem
  - Hydraulic, electrical or mechanical - Read the trouble shooting section
  - Tractor or Truck chassis - Contact vehicle dealer
  
- If unable to correct the problem yourself, contact your local Tiger Dealer after gathering:
  - Machine model \_\_\_\_\_
  - Serial number \_\_\_\_\_
  - Dealer name \_\_\_\_\_
  - Detailed information about the problem including results of troubleshooting

**Attention Owner / Operator / Dealer:** It is your obligation to read, and understand, the warranty information section located at the back of this manual denoting that the purchaser understands the safety issues relating to this machine and has received and will read a copy of this manual.

If at any time, you have a service problem with your Tiger mower, Contact your local dealer for service and parts needed.

MANUFACTURED BY:

**Tiger Corporation**

3301 N. Louise Ave.

Sioux Falls, SD 57107

1-800-843-6849

1-605-336-7900

www.tiger-mowers.com

DISTRIBUTED BY:

\_\_\_\_\_

1- \_\_\_\_\_ - \_\_\_\_\_ - \_\_\_\_\_

1- \_\_\_\_\_ - \_\_\_\_\_ - \_\_\_\_\_



# TABLE OF CONTENTS

SAFETY SECTION_____	1
ASSEMBLY / MOUNTING SECTION_____	2
OPERATION SECTION_____	3
MAINTENANCE SECTION_____	4
PARTS SECTION_____	5
COMMON PARTS SECTION_____	6
WARRANTY INFORMATION_____	7



1012

**This symbol means:**

**CAUTION – YOUR SAFETY IS AT RISK!**

When you see this symbol, read and follow the associated instructions carefully or personal injury or damage may result.

Tiger is a registered trademark.





# **SAFETY SECTION**

# SAFETY

## GENERAL SAFETY INSTRUCTIONS AND PRACTICES

A careful operator is the best operator. Safety is of primary importance to the manufacturer and should be to the owner/operator. Most accidents can be avoided by being aware of your equipment, your surroundings, and observing certain precautions. The first section of this manual includes a list of Safety Messages that, if followed, will help protect the operator and bystanders from injury or death. Read and understand these Safety Messages before assembling, operating or servicing this Implement. This equipment should only be operated by those persons who have read the manual, who are responsible and trained, and who know how to do so responsibly.



The Safety Alert Symbol combined with a Signal Word, as seen below, is used throughout this manual and on decals which are attached to the equipment. The Safety Alert Symbol means: "ATTENTION! BECOME ALERT! YOUR SAFETY IS INVOLVED!" The Symbol and Signal Word are intended to warn the owner/operator of impending hazards and the degree of possible injury faced when operating this equipment.

Practice all usual and customary safe working precautions and above all--- remember safety is up to YOU. Only YOU can prevent serious injury or death from unsafe practices.



Indicates an imminently hazardous situation that, if not avoided, WILL result in DEATH OR VERY SERIOUS INJURY.



Indicates an imminently hazardous situation that, if not avoided, COULD result in DEATH OR SERIOUS INJURY.



Indicates an imminently hazardous situation that, if not avoided, MAY result in MINOR INJURY.



Identifies special instructions or procedures that, if not strictly observed, could result in damage to, or destruction of the machine, attachments or the environment.

**NOTE:** Identifies points of particular interest for more efficient and convenient operation or repair.

READ, UNDERSTAND, and FOLLOW the following Safety Messages. Serious injury or death may occur unless care is taken to follow the warnings and instructions stated in this Manual and in the Safety Messages on the implement. Always follow the instruction in this manual and use good common sense to avoid hazards.

**NOTE:** If you want a translation of this safety section in one of the following Languages, please contact: Translations at 1502 E. Walnut Street Seguin, TX 78155; Fax: (830) 372-9529; Safety Section Translations are available in Spanish, Portuguese, French, German, Russian.



# SAFETY

## OPERATOR SAFETY

				
Read and understand Operator's Manual	Always wear Safety Glasses	Wear Hard Hat Safety Shoes	Never use Drugs or Alcohol when operating equipment	Wear Safety Vest when operating on or near roads

### TO AVOID SERIOUS INJURY OR DEATH DO THE FOLLOWING:

- **READ, UNDERSTAND and FOLLOW** Operator's Manual instructions, Warnings and Safety Messages.
- **WEAR SAFETY GLASSES**, safety shoes, hard hat, hearing protection and gloves when operating or repairing equipment
- **WEAR** appropriate breathing respirator when operating in dusty conditions to avoid respiratory diseases.
- **DO NOT WEAR** loose clothing or jewelry to avoid rotating parts entanglement injury.
- **DO NOT USE DRUGS or ALCOHOL** before or while operating equipment.
- **DO NOT ALLOW** anyone to operate equipment under the influence of drug or alcohol.
- **CONSULT** medical professional for medication impairment side effects.
- **STAY ALERT**, prolonged operation can cause fatigue, STOP and REST.

### GENERAL OPERATING SAFETY

#### **VISIBILITY CONDITIONS WHEN MOWING:**

- **OPERATE IN DAYLIGHT** or with lights that gives at least 100 yards clear visibility.
- **BE ABLE TO SEE** and identify passersby, steep slopes, ditches, drop-offs, overhead obstructions, power lines, debris and foreign objects.

#### **GROUND SPEED WHEN MOWING:**

- **NORMAL SPEED** range is between 2 to 5mph.
- **ADJUST MOWING SPEED** for terrain conditions and grass type, density and cut height.
- **REDUCE MOWING SPEED** when near steep slopes, ditches, drop-offs, overhead obstructions, power lines and to avoid debris and foreign objects.

#### **INSECT INFESTATION**

- Do Not operate in areas where bees or insects may attack unless you **WEAR PROTECTIVE CLOTHING** or use enclosed tractor cab.

#### **PTO SPEED:**





- **DO NOT EXCEED IMPLEMENT RATED PTO SPEED**
- **AVOID** exceeding rated PTO speeds that may result in broken drivelines or blade failures.

#### **SAFETY SIGNS:**

- **REPLACE** missing, damaged or unreadable safety signs immediately.

# SAFETY

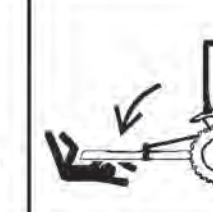
## CRUSHING HAZARDS

				
Crushing injury from roll over	Lock ROPS in up position	Always wear seatbelt	Crushing injury implement falling	Crushing injury wing falling

**⚠ DANGER** TO AVOID SERIOUS INJURY OR DEATH FROM FALLING OFF TRACTOR, EQUIPMENT RUN OVER, ROLLOVER AND CRUSHING BY FALLING WING OR IMPLEMENT:

- USE ROPS and SEAT BELT equipped tractors for mowing operations.
- KEEP ROPS lock in up position.
- ALWAYS BUCKLE UP seat belt when operating tractor and equipment.
- ONLY OPERATE tractor and equipment while seated in tractor seat.

### **WHEN RAISING OR LOWERING WINGS:**

- Raise or lower ONLY WHILE SEATED in tractor seat with seat belt buckled.
- KEEP BYSTANDERS CLEAR of area TO AVOID crushing.
- KEEP sufficient clearance around implement and wings TO AVOID contacting buildings or overhead power lines.

LIFTED Equipment can fall from mechanical or hydraulic failure or inadvertent Control Lever movement.

**⚠ WARNING** TO AVOID EQUIPMENT FALLING while working near or under lifted wings, components and implements raised by 3-Pointed tractor hitch:

- SECURELY SUPPORT or block up raised equipment, wings and components.
- BLOCK UP and securely support equipment before putting hands, feet or body under raised equipment or lifted components.
- KEEP BYSTANDERS CLEAR of folded wings until wings are blocked or locked up.

### **WHEN PARKING** Implement and Tractor:

- LOWER implement, LOCK or BLOCK lifted parts before leaving equipment.
- NEVER leave implement unattended in a raised position.

**⚠ WARNING** TO AVOID CHILDREN FALLING OFF OR BEING CRUSHED BY EQUIPMENT:

- NEVER ALLOW children to play on or around Tractor or Implement.

### **WHEN UNHITCHING IMPLEMENT:**



- LOWER implement, LOCK or BLOCK lifted parts before leaving equipment.

### **BEFORE REMOVING Wing Retaining Lock:**

- ATTACH hoses to tractor.
- FILL Wing Cylinders with oil. (Refer to Instructions in Operation Section)
- KEEP bystanders away before operating wings.
- LOWER WINGS slowly and carefully.

# SAFETY

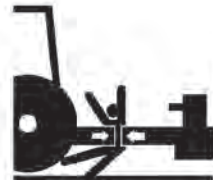
## CONNECTING OR DISCONNECTING IMPLEMENT SAFETY

				
Stop Tractor Remove Key Read Manual	Crushing injury between tractor and implement	Crushing injury wing falling	Make sure PTO shaft is securely attached to tractor	Make sure PTO shaft are proper length



**TO AVOID SERIOUS INJURY OR DEATH FROM BEING CRUSHED BY TRACTOR OR IMPLEMENT:**

### **WHEN BACKING tractor to implement hitch:**

- DO NOT ALLOW BYSTANDERS between tractor and implement.

### **BEFORE connecting and disconnecting implement hitch:**

- STOP TRACTOR ENGINE, place transmission into park, engage parking brake and remove key.

### **WHEN connecting and disconnecting implement hitch:**

- DO NOT crawl or walk under raised mower or wing.

### **WHEN CONNECTING IMPLEMENT DRIVELINE:**

#### **TO AVOID implement driveline coming loose during operation:**

- LUBRICATE yoke spring locking collar to ensure it freely slides on PTO shaft.
- SECURELY seat yoke locking balls in PTO shaft groove.
- PUSH and PULL DRIVELINE on both the tractor and implement PTO SHAFTS to ensure it is SECURELY ATTACHED.

#### **TO AVOID broken driveline during operations:**

- CHECK driveline for proper length between PTO shaft and implement gearbox shaft. (Refer to Instructions in Operation Section)
- Drivelines too short can pull apart or disengage.
- Drivelines too long can bottom out.
- Bottoming driveline telescoping assembly will stop sliding and become solid.
- Driveline bottoming can push through support bearings and break off PTO shaft.

#### **CONTACT DEALER if implement driveline does not match Tractor PTO shaft:**

- DO NOT USE PTO ADAPTER.  
Using a PTO adapter can cause:
  - Excessive vibration, thrown objects, blade and implement failures by doubling operating speed.
  - Increased working length exposing unshielded driveline areas and entanglement hazards.

#### **BEFORE REMOVING WING RETAINING LOCKS:**

- FILL Wing Cylinders with oil. (Refer to Instructions in Operation Section)
- KEEP bystanders clear of area before operating wings.
- LOWER WINGS slowly and carefully.

**DO NOT connect the Mower to a tractor with the PTO directly connected to the Tractor transmission.**

# SAFETY

SAFETY

## THROWN OBJECTS HAZARDS

			
Mower Thrown Objects Hazard	Raised Mower Thrown Objects	Inspect Area remove foreign objects	Do not let blades contact solid objects

**⚠ DANGER** ROTARY MOWERS CAN THROW OBJECTS 300 FEET OR MORE UNDER ADVERSE CONDITIONS.

**TO AVOID SERIOUS INJURY OR DEATH TO OPERATOR OR BYSTANDERS FROM THROWN OBJECTS:**

- KEEP bystanders 300 feet away

**STOP MOWING IF PASSERSBY ARE WITHIN 300 FEET UNLESS:**

- All THROWN OBJECT SHIELDING including, Front and Rear Deflectors, Steel Guards, Bands, Side Skirts and Skid Shoes in place and in good condition when mowing.
- Mower sections or wing are adjusted to be close and parallel to ground without exposing blades.
- MOWING AREA has been inspected and foreign materials and debris have been removed.
- PASSERSBY are inside enclosed vehicle.

**INSPECT AREA FOR POTENTIAL THROWN OBJECTS BEFORE MOWING:**

- REMOVE debris, rocks, wire, cable, metal objects and other foreign material from area. Wire, cable, rope, chains and metal objects can be thrown or swing outside deck with great velocity:
  1. MARK objects that cannot be removed.
  2. AVOID these objects when mowing.

**HIGH GRASS and WEED AREA INSPECTION:**

- INSPECT for and REMOVE any hidden large debris.
- MOW at Intermediate height
- INSPECT and remove remaining debris
- MOW at final height.

**MOWER THROWN OBJECT SHIELDING:**



- KEEP all thrown object shielding including, Front and Rear Deflectors, Steel Guards, Bands, Side Skirts and Skid Shoes in place and in good condition when mowing.
- DO NOT OPERATE with any thrown object shielding missing, damaged or removed.

**RIGHT OF WAY (Highway) MOWING**

- No shielding is 100% effective in preventing thrown objects. To Reduce Possibility of Injury:
  1. MAINTAIN MOWER SHIELDING, side skirts, skid shoes, and blades in good operational condition,
  2. RAISE CUTTING HEIGHT to 6 INCHES minimum,
  3. INSPECT AREA thoroughly before mowing to REMOVE potential THROWN OBJECT HAZARDS,
  4. NEVER ALLOW BLADES to CONTACT SOLID OBJECTS like wire, rocks, post, curbs, guardrails, or ground while mowing.

# SAFETY

## THROWN OBJECTS HAZARD (CONTINUED)

			
<p>Mower Thrown Objects Hazard</p>	<p>Raised Mower Thrown Objects</p>	<p>Inspect Area remove foreign objects</p>	<p>Do not let blades contact solid objects</p>

### MOWER OPERATION:

- **DO NOT** exceed mower's rated Cutting Capacity or cut non-vegetative material.
- **USE ENCLOSED TRACTOR CABS** when two or more mowers are operating in mowing area.
- **ADJUST** mower sections or wing close and parallel to ground without exposing blades
- **ADJUST** cutting **HEIGHT** to **AVOID BLADE CONTACT** with solid objects like wire, rocks, posts, curbs, guard rails and fixed obstructions.
- **DO NOT** operate mower when mower is raised or in transport position
- **STOP MOWING** immediately if blades strike heavy objects, fixed structures, metal guard rails and concrete structures:
  1. **BLADES CAN FAIL** from impact and objects can be thrown with great velocity.
  2. **INSPECT and REPLACE** any damaged blades.
  3. **CHECK** blade carrier balance and **REPLACE** if damaged.
- **DO NOT** mow in standing water **TO AVOID** possible **BLADE FAILURE**.
- **AVOID MOWING** in reverse:
  1. **STOP PTO** and back up mower.
  2. **LOWER** mower, engage **PTO** and mow forward.
- **STOP PTO and BLADES** when raising the mower to transport position.
- **DO NOT ENGAGE PTO** with mower in transport position.
- **STOP** mowing when **EXCESSIVE VIBRATION** occurs:
  1. **STOP PTO** and tractor **ENGINE**.
  2. **INSPECT** mower for vibration source
  3. **REPLACE** any damage parts and bent or damaged **BLADES**.

# SAFETY

## RUN OVER HAZARDS



**⚠ DANGER** TO AVOID SERIOUS INJURY OR DEATH FROM FALLING OFF TRACTOR OR EQUIPMENT RUN OVER:



- **USE ROPS and SEAT BELT** equipped tractors for mowing operations.
- **KEEP ROPS** locked in **UP** position.
- **ONLY** start tractor while seated in tractor seat.
- **ALWAYS BUCKLE UP** seat belt when operating tractor and equipment.
- **ONLY OPERATE** tractor and equipment while seated in tractor seat.
- **NEVER ALLOW RIDERS** on tractor or implement.

### WHEN MOUNTING AND DISMOUNTING TRACTOR:

- **ONLY** mount or dismount when tractor and moving parts are stopped.
- **STOP ENGINE AND PTO**, engage parking brake, lower implement, allow all moving parts to stop and remove key before dismounting from tractor.

# SAFETY

## PTO ENTANGLEMENT HAZARDS

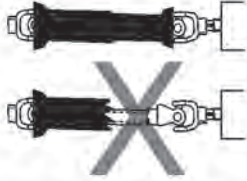
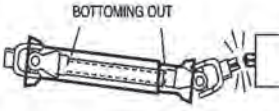
	 <p>PTO (Barra Gitatoria)</p>		 <p>BOTTOMING OUT</p>
<p>Entanglement hazard Do Not approach or touch a rotating PTO driveshaft</p>	<p>Make sure PTO shaft is securely attached Do Not Use PTO Adapter</p>	<p>DO NOT Operate if PTO shields are damaged or missing</p>	<p>Make sure PTO shafts are proper length</p>



**KEEP AWAY FROM ROTATING DRIVELINES AND ELEMENTS TO AVOID SERIOUS INJURY OR DEATH:**

**STAY AWAY** and **KEEP** hands, feet and body **AWAY** from rotating blades, drivelines and parts until all moving elements have stopped.

- **STOP, LOOK** and **LISTEN** before approaching the mower to make sure all rotating motion has stopped.
- **ROTATING COMPONENTS CONTINUE** to **ROTATE** after the **PTO** is shut off.

### **PTO SHIELDING:**

#### **TO AVOID SERIOUS INJURY OR DEATH FROM ENTANGLEMENT WHEN OPERATING IMPLEMENT:**

- **KEEP** PTO shields, integral driveline shields and input shields installed
- **DO NOT OPERATE** mower without shields and guards in place or missing
- **REPAIR OR REPLACE** if damage, broken or missing
- **ALWAYS REPLACE GUARDS** that have been removed for service or maintenance.
- **DO NOT** use PTO or PTO guard as a step.

#### **TO AVOID** broken driveline during operations:

- **CHECK** driveline for proper length between PTO shaft and implement gearbox shaft. (Refer to Instructions in Operation Section)
- Drivelines too short can pull apart or disengage.
- Drivelines too long can bottom out.  
Bottoming driveline telescoping assembly will stop sliding and become solid.
- Driveline bottoming can push through support bearings and break off PTO shaft
- **AVOID** sharp turns or lift mower to heights to cause driveline "knocking".
- Lubricate driveshaft-telescoping components weekly.

**CONTACT DEALER** if implement driveline does not match Tractor PTO shaft:

- **DO NOT USE PTO ADAPTER.**

Using a PTO adapter can cause excessive vibration, thrown objects, blade and implement failures by doubling operating speed. Increased working length exposing unshielded driveline areas.

# SAFETY

## MOWER BLADE CONTACT HAZARDS

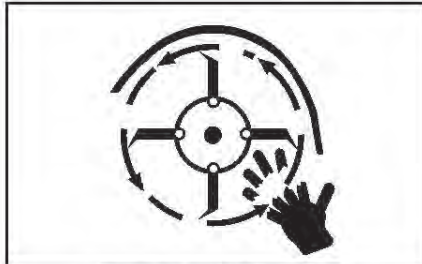

Do not put fingers underneath mower

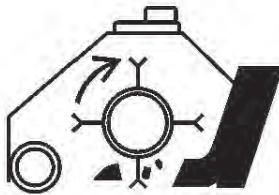

Do not put foot underneath mower



Stop Tractor Remove Key  
Read Manual



**KEEP AWAY FROM ROTATING BLADES TO AVOID SERIOUS INJURY OR DEATH FROM BLADE CONTACT:**

- **STAY AWAY** and **KEEP HANDS, FEET** and **BODY AWAY** from rotating blades, drivelines and parts until all moving elements have stopped.
- **DO NOT** put hands or feet under mower decks
- **STOP** rotating **BLADES** disengage PTO and wait for blade to stop rotating before raising mower deck or wings
- **STOP, LOOK** and **LISTEN** before approaching the mower to make sure all rotating motion has stopped.



# SAFETY

## HIGH PRESSURE OIL LEAK HAZARD

			
High pressure oil penetrating skin	High pressure oil eroding skin	Using cardboard to check for oil leaks	Tank contents under pressure. Allow oil to cool before slowly removing cap

**⚠ DANGER** TO AVOID SERIOUS INJURY OR DEATH FROM HIGH PRESSURE HYDRAULIC OIL LEAKS PENERATING SKIN:

- **DO NOT OPERATE** equipment with oil or fuel leaks.
- **KEEP** all hydraulic hoses, lines and connections in **GOOD CONDITION** and **TIGHT** before applying system pressure.
- **RELIEVE HYDRAULIC PRESSURE** before disconnecting lines or working on the system.
- **REMOVE** and replace hose if you suspect it leaks. Have dealer test it for leaks.

### **HIGH PRESSURE FLUID LEAKS CAN BE INVISIBLE.**

#### **WHEN CHECKING FOR HYDRAULIC LEAKS AND WORKING AROUND HYDRAULIC SYSTEMS:**



- **ALWAYS WEAR** safety glasses and impenetrable gloves.
- **USE** paper or cardboard to search for leaks.
- **DO NOT USE** hands or body parts to search for leak.
- **KEEP** hands and body **AWAY** from pin holes and nozzles ejecting hydraulic fluid.
- Hydraulic fluid may cause gangrene if not surgically removed immediately by a doctor familiar with this form of injury.

#### **Use Caution when removing Hydraulic Tank cap.**

- Tank content maybe under pressure.
- Allow oil to cool before removing cap.
- Relieve oil pressure before removing cap slowly.
- Stay away from hot oil that may spray from tank.

# SAFETY

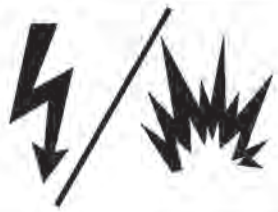
## ELECTRICAL & FIRE HAZARDS

		
Wing contacting overhead electrical lines	Strike and explosion Hazard Blades Contacting Utility or Gas Lines	Do not operate near fires. Keep mower deck clear of debris

### **⚠ DANGER**

**TO AVOID SERIOUS INJURY OR DEATH FROM ELECTRICAL CONTACT WHEN WORKING AROUND ELECTRICAL POWER LINES, GAS LINES AND UTILITY LINES:**



- **INSPECT** mowing area for overhead or underground electrical power lines, obstructions, gas lines, cables and Utility, Municipal, or other type structure.
- **KEEP** all raised wings at a 10 feet or greater distance from all power lines and overhead obstructions.
- **DO NOT** allow mower to contact with any Utility, Municipal, or type of structures and obstructions.
- **CALL 811** and 1-800-258-0808 for identify buried utility lines.

**FIRE PREVENTION GUIDELINES** while Operating, Servicing, and Repairing Mower and Tractor to reduce equipment and grass fire Risk:

- **EQUIP** Tractor with a **FIRE EXTINGUISHER**
- **DO NOT OPERATE** mower on a tractor equipped with under frame exhaust
- **DO NOT SMOKE** or have open flame near Mower or Tractor
- **DO NOT DRIVE** into burning debris or freshly burnt area
- **AVOID FIRE IGNITION** by not allowing mower blade to contact solid objects like metal or rock.
- **ADJUST SLIP CLUTCHES** to avoid excessive slippage and clutch plate heating.
- **CLEAR** any grass clippings or debris buildup around mower drivelines, slip clutches, and gearboxes.
- **SHUT OFF ENGINE** while refueling.
- Do not operate if oil is leaking. Repair oil leak and remove all accumulated oil before operating.
- **CLEAR** any grass clippings or debris buildup around mower hydraulic pumps, valves or tanks

# SAFETY

## TRANSPORTING HAZARDS

				
Use SMV signs and Flashing Lights	Loss of Control Stopping Hazard	Loss of Control Speeding Hazard	Use Safety Tow Chain - Tractor to Implement	Engage Transport Locks

### **⚠ WARNING** TO AVOID SERIOUS INJURY AND DEATH WHEN TOWING OR TRANSPORTING EQUIPMENT:

- **KEEP** transport speed **BELOW 20** mph to maintain control of equipment.
- **REDUCE SPEED** on inclines, on turns and in poor towing conditions.
- **DO NOT TOW** with trucks or other vehicles.
- **USE** only properly sized and equipped tractor for towing equipment.
- **FOLLOW** all local traffic regulations.

### **TRACTOR REQUIREMENTS FOR TOWING OR TRANSPORTING IMPLEMENTS:**

- **ONLY TRANSPORT** with tractor with ROPS in the raised position.
- **USE** properly sized and equipped tractor that exceeds implement weight by at least 20%.
- **KEEP** 20% of tractor weight on front wheels to maintain safe steering.

### **BEFORE TRANSPORTING OR TOWING IMPLEMENT:**

#### **TRACTOR INSPECTION:**

- **CHECK** steering and braking for proper operation and in good condition.
- **CHECK** SMV sign, reflectors and warning lights for proper operation and visibility behind unit.
- **CHECK** that your driving vision is not impaired by tractor, cab, or implement while seated in tractor seat.
- **ADJUST** your operating position, mirrors, and implement transport for clear vision for traveling and traffic conditions.

### **PREPARE IMPLEMENT FOR TRANSPORTING OR TOWING:**

#### **ENGAGE TRANSPORT LOCKS AND SAFETY CHAINS:**

- **RAISE MOWER** and **ENGAGE** center axle cylinder transport stops or pins.
- **RAISE WINGS** and **ENGAGE TRANSPORT LOCKS** or pins.
- **ATTACH** implement **SAFETY CHAIN** to tractor.
- **REMOVE** any cut material collected on mower deck.

### **DETERMINE STOPPING CHARACTERISTICS OF TRACTOR AND IMPLEMENT FOR TRANSPORTING OR TOWING:**

#### **BRAKING TESTS:**

- **INSTALL** center axle cylinder transport stops or pins.
- Observe **STOPPING** distances increases with increased speeds.
- **DETERMINE** the maximum safe transport speed that does not exceed 20 mph.

### **DETERMINE MAXIMUM TURNING SPEED BEFORE OPERATING ON ROADS OR UNEVEN GROUND:**

- **TEST** equipment in slowly increasing speed in turns to determine it can be operated at higher speeds.
- **USE REDUCED** turning speeds in sharp turns to avoid equipment turning over.





### **WHEN TOWING OR TRANSPORTING EQUIPMENT:**

- Always **WEAR SEAT BELT** when operating or transporting mower.
- **USE** low speeds to avoid overturn with raised wings.
- **USE** low speeds and gradual steering on curves, hills, rough or uneven surfaces and on wet roads.
- **TURN ON** tractor **FLASHING WARNING LIGHTS**.
- **ALLOW** clearance for implement swing while turning.

**KEEP** all raised wings at 10 feet or greater distance from all power lines and overhead obstructions.

# SAFETY

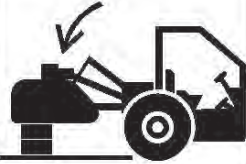
## HAZARDS WITH MAINTENANCE OF IMPLEMENT

				
Periodically inspect all moving parts, lubricate drivelines, and tighten all fasteners	Stop engine remove key before conducting maintenance	Block up implement before servicing Use large blocks on soft or wet soil	Engage cylinder transport locks	Inspect Blades for damage or cracks

**⚠ WARNING** AVOID SERIOUS INJURY OR DEATH FROM COMPONENT FAILURE BY KEEPING IMPLEMENT IN GOOD OPERATING CONDITION IN PERFORMING PROPER SERVICE, REPAIRS AND MAINTENANCE. BEFORE PERFORMING SERVICE, REPAIRS AND MAINTENANCE ON THE IMPLEMENT:

- **STOP ENGINE AND PTO**, engage parking brake, lower implement, allow all moving parts to stop and remove key before dismounting from tractor.
- **PLACE** implement on ground or securely block up raised equipment. Use large blocks on soft or wet soil.
- **PUSH and PULL** Remote Hydraulic Cylinder lever to relieve hydraulic pressure.
- **DISCONNECT IMPLEMENT** driveline from tractor **PTO SHAFT**.

**WEAR SAFETY GLASSES, PROTECTIVE GLOVES** and follow **SAFETY PROCEDURES** when performing service, repairs and maintenance on the implement:

- Always **WEAR** protective **GLOVES** when handling blades, knives, cutting edges or worn component with sharp edges.
- Always **WEAR GLOVES** and **SAFETY GLASSES** when servicing hot components
- **AVOID CONTACT** with hot hydraulic oil tanks, pumps, motors, valves and hose connection surfaces.
- **SECURELY** support or **BLOCK UP** raised implement, framework and lifted components before working underneath equipment.
- **STOP** any implement movements and **SHUT-OFF TRACTOR** engine before doing any work procedures.
- **USE** ladder or raised stands to reach high equipment areas inaccessible from ground.
- **ENSURE** good footing by standing on solid flat surfaces when getting on implement to perform work.
- **FOLLOW** manufacturer's instructions in handling oils, solvents, cleansers, and other chemical agents.
- **DO NOT** change any factory-set hydraulic calibrations to avoid component or equipment failures.
- **DO NOT** modify or alter implement, functions or components.
- **DO NOT WELD** or repair rotating mower components. These may cause vibrations and component failures being thrown from mower.

**PERFORM SERVICE, REPAIRS, LUBRICATION AND MAINTENANCE OUTLINED IN IMPLEMENT MAINTENANCE SECTION:**

- **INSPECT** for loose fasteners, worn or broken parts, leaky or loose fittings, missing or broken cotter keys and washers on pins, and all moving parts for wear.
- **REPLACE** any worn or broken parts with authorized service parts.
- **LUBRICATE** unit as specified by lubrication schedule
- **NEVER** lubricate, adjust or remove material while it is running or in motion.
- **TORQUE** all bolts and nuts as specified.

**BLADE INSPECTION:**

- **REPLACE** bent, damage, cracked or broken blades immediately with new blades.
- **AVOID** blade failures and thrown broken blades. **DO NOT** straighten, weld, or weld hard-facing blades.

**SAFETY SHIELDS, GUARDS AND SAFETY DEVICES INSPECTION:**

- **KEEP** all Deflectors, Steel Guards, Gearbox Shields, and PTO integral shields, Bands, Side Skirts and Skid Shoes in place and in good condition.
- **REPLACE** any missing, broken or worn safety shields, guards and safety devices.
- Engine Exhaust, some of its constituents, and certain vehicle components contain or emit chemicals known to the state of California to cause cancer, birth defects or other reproductive harm.
- Battery posts, terminals and related accessories contain lead and lead compounds, chemicals known to the state of California to cause cancer, birth defects or other reproductive harm.
- **DISCONNECT** Pump solenoid valve or PTO driveline connection before servicing mower head.
- **FOLLOW INSTRUCTIONS** in maintenance section when replacing hydraulic cylinders to prevent component falling.

# SAFETY

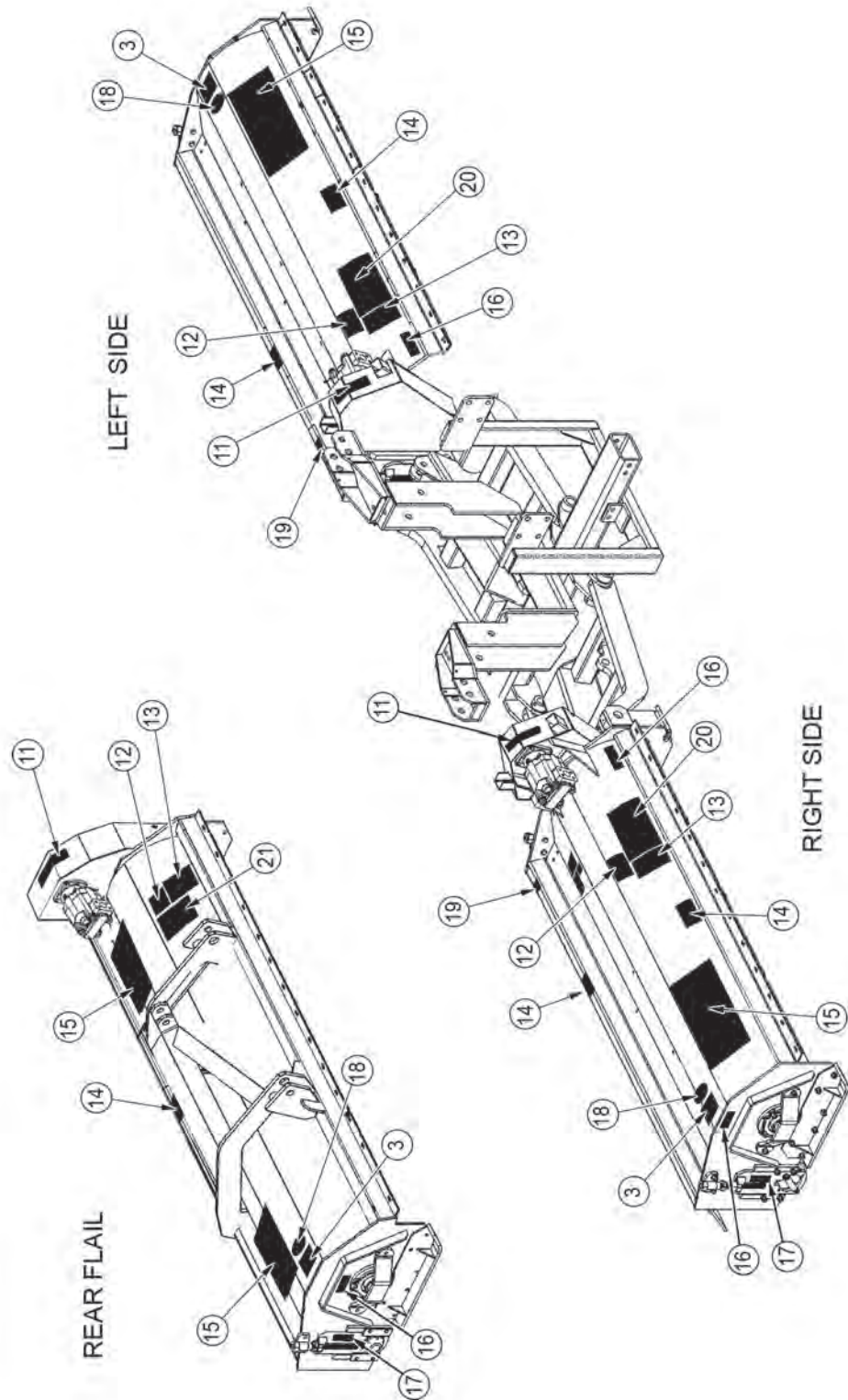

SAFETY

Safety Section 1-15

# SAFETY

SAFETY

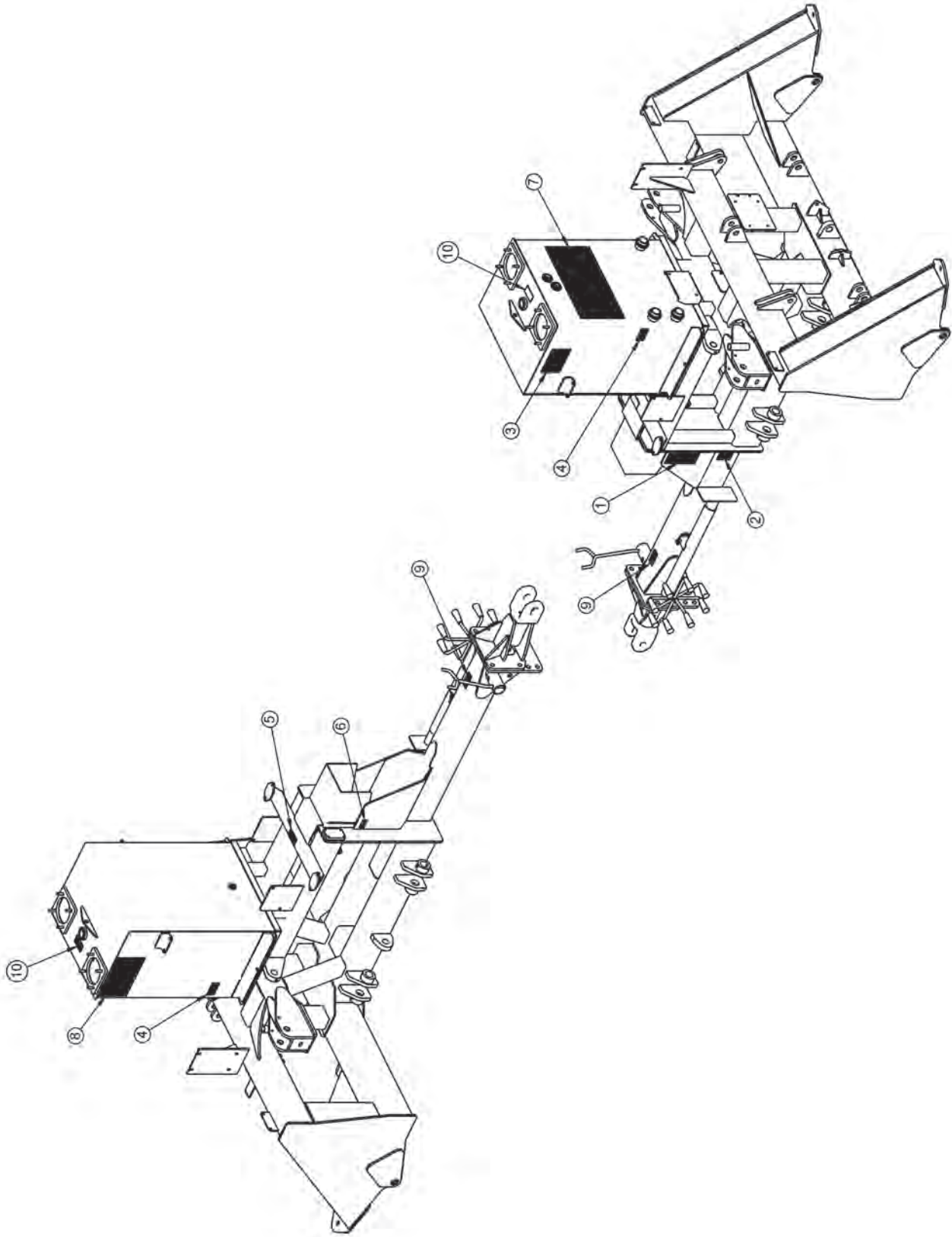

Safety Section 1-16

# SAFETY

ITEM	PART NO.	QTY.	TYPE	DESCRIPTION
1.	D547	1	INSTRUCT	1000 RPM PTO
2.	D482	1	WARNING	Jack Safety
3.	6T3236	4	LOGO	Made with Pride in USA
4.	6T3233	2	IMPORTANT	Valve Position
5.	6T3220	6	IMPORTANT	Lubricate Pump Drive Shaft Daily
6.	-----	1	INFORMATION	Serial Number Tag
7.	31522	1	LOGO	Tiger Logo (10" x 5.5")
8.	D836	1	DANGER	Multi-Language General Safety
9.	D102	1	INSTRUCT	Safety Chain
10.	02971123	1	WARNING	Pressurized Tank
11.	00758194	3	WARNING	Pinch Points
12.	D637	3	WARNING	Disconnect Hydraulic Solenoid
13.	D698	3	DANGER	Crushing Hazard - Injury or Death
14.	24028	6	DANGER	Thrown Object Hazard
15.	31523	4	LOGO	Tiger Logo (18.25" x 10")
16.	22839	3	INSTRUCT	Do Not Lubricate with Automatic Grease Gun
17.	06550095	3	INSTRUCT	Standard/Smooth Cut Measurements
18.	-----	3	LOGO	Tiger Certified Parts
19.	D703	3	DANGER	Crushing Hazard
20.	D706	2	INSTRUCT	Lubrication Instruction Side Flail
21.	D700	1	INSTRUCT	Lubrication Instruction Rear Flail

SAFETY

# SAFETY

SAFETY

<b>⚠ DANGER</b>	<b>⚠ PELIGRO</b>
<p><b>TO AVOID SERIOUS INJURY OR DEATH FROM DRIVELINE CONTACT, DRIVELINE SEPARATION OR PTO STUB SHAFT FAILURE:</b></p> <ul style="list-style-type: none"> <li>• STOP, LOOK and LISTEN for rotating motion before approaching implement.</li> <li>• STAY AWAY and KEEP hands, feet and body AWAY from rotating parts until all moving elements have stopped.</li> <li>• ALWAYS shut off PTO before dismounting.</li> <li>• DO NOT operate if PTO shields are damaged or missing.</li> <li>• LOCK DRIVELINE locking collar YOKE to tractor PTO Shaft.</li> <li>• PUSH AND PULL on yoke until collar clicks and locks yoke in place.</li> <li>• USE CORRECT length drivelines for implement. (See Operator's Manuals for procedure)</li> <li>• CHECK driveline guards for free rotation and sufficient overlap to avoid unshielded areas.</li> <li>• DO NOT USE PTO ADAPTER</li> </ul>	<p><b>PARA EVITAR LESION SERIA O MUERTE POR CONTACTO A LA LÍNEA DE CONDUCCIÓN, SEPARACION DE LÍNEA DE CONDUCCIÓN O EL FRACASO DEL EJE DE PTO:</b></p> <ul style="list-style-type: none"> <li>• PARE, MIRE y ESCUCHE por el movimiento de rotación antes de acercarse al implemento.</li> <li>• MANTENGASE ALEJADO y MANTENGA manos, pies y cuerpo LEJOS de partes girando, hasta que todos los elementos de movimiento se han parado.</li> <li>• SIEMPRE apague la Toma De Fuerza (Barra Gitatoria) antes de desmontar.</li> <li>• NO opere si las cubiertas de Toma De Fuerza (Barra Gitatoria) estan dañadas.</li> <li>• TRABE el YUGO de collar de fijación del la LÍNEA DE CONDUCCIÓN al eje de PTO (Barra Gitatoria) del tractor.</li> <li>• EMPUJE Y JALE el yugo hasta que el collar de fijación hace clic y el yugo se traba en lugar.</li> <li>• USE la longitud de línea de conducción CORRECTA para el implemento. (Vea el Manual de Operador para el Procedimiento)</li> <li>• REVISE las guardias de línea de conducción por giracion libre y suficiente traslape para evitar areas sin cobertura.</li> <li>• NO UTILICE UN ADAPTOR PARA LA TOMA DE FUERZA (Barra Gitatoria).</li> </ul>
<p>D547-1</p>	<p>D547</p>

<b>⚠ WARNING</b>	<b>⚠ ADVERTENCIA</b>
<p>OPERATE THIS MACHINE AT <b>1000 RPM</b> TRACTOR PTO SPEED ONLY. Overspeeding PTO may cause component failure resulting in bodily injury. TRACTOR PTO ROTATION: CLOCKWISE</p>	<p>OPERE ESTA MÁQUINA A <b>1000 RPM</b> SOLAMENTE OPERE ESTA MÁQUINA A LA VELOCIDAD DE PTO (TOMA DE FUERZA O BARRA GITATORIA) DEL TRACTOR DE 540 RPM. El sobre exceso de velocidad de PTO puede causar el fracaso de componente que resultara en lesión. ROTACION DE PTO DEL TRACTOR: EN SENTIDO HORARIO</p>
	
<p>D547-2</p>	



# SAFETY

**⚠ WARNING**

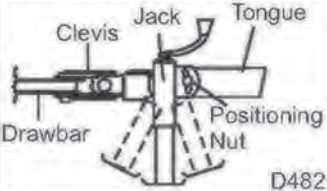

D482

Rated Vertical Loads:	3000 lbs
Side:	675 lbs

**TO AVOID SERIOUS INJURY:**

- Fully engage jack retaining pin.
- Adjust jack vertically.
- Torque positioning nut to 250 ft-lbs.
- DO NOT exceed rated loads.

**IMPORTANT**

DO NOT operate PTO/Mower with valve in the off position. Severe damage to the pump and motor can result.

6T3233

# SAFETY

SAFETY

<p><b>⚠ DANGER</b></p>  <p><b>Run Over Hazard - Injury or Death</b></p> <p><b>TO AVOID SERIOUS INJURY OR DEATH:</b></p> <ul style="list-style-type: none"> <li>• ALWAYS BUCKLE UP seat belt.</li> <li>• ONLY START Tractor while seated in the operator's seat.</li> <li>• STOP ENGINE and PTO, engage parking brake, lower implement, allow all moving parts to stop and remove key before dismounting from tractor.</li> <li>• KNOW HOW to stop tractor and equipment quickly for an emergency.</li> <li>• DO NOT MOUNT or DISMOUNT Tractor in motion.</li> <li>• NEVER ALLOW riders on tractor or implement.</li> <li>• NEVER ALLOW children to operate or ride on tractor or implement.</li> <li>• KEEP BYSTANDERS CLEAR of area before moving tractor or implement.</li> <li>• KEEP ALERT and AVOID hitting stumps, holes, ruts, and uneven terrain.</li> <li>• AVOID tree limbs, brush and other overhanging objects that can strike and throw the operator from seat.</li> </ul> <p>D836_1</p>		<p><b>⚠ DANGER</b></p>  <p><a href="http://www.algqr.com/tbe">www.algqr.com/tbe</a></p> <p><b>TO AVOID SERIOUS INJURY OR DEATH:</b></p> <ul style="list-style-type: none"> <li>• READ AND UNDERSTAND the provided Operator's Manuals, safety signs and information decals for tractor and implement before operating equipment.</li> <li>• CONTACT DEALER immediately if you do not have manuals.</li> <li>• CONTACT DEALER to explain any instructions not fully understood.</li> <li>• ALWAYS WEAR safety glasses.</li> <li>• WEAR hard hat, safety shoes and gloves for protection when operating equipment.</li> </ul> <p>D836_2</p>	
<p><b>⚠ PELIGRO</b></p> <p>Si no puede leer inglés: antes de poner en funcionamiento este equipo, solicite que alguien le traduzca los mensajes de seguridad o vaya al sitio web para consultar los mensajes de seguridad y las etiquetas ya traducidos.</p> <p>El Manual del Operador Seguridad video</p>  <p><a href="http://www.algqr.com/tbs">www.algqr.com/tbs</a></p>	<p><b>⚠ DANGER</b></p> <p>Si vous ne savez pas lire le français: avant d'utiliser l'équipement, demandez à une personne de vous traduire les messages de sécurité ou allez sur le site Internet pour voir la traduction des autocollants et des messages de sécurité.</p> <p>Manuel de l'Opérateur</p>  <p><a href="http://www.algqr.com/tbf">www.algqr.com/tbf</a></p>	<p><b>⚠ PERIGO</b></p> <p>Caso você não leia inglês: antes de operar o equipamento, peça para alguém traduzir as mensagens de segurança ou visite a web e obtenha tais mensagens ou os decalques traduzidos.</p> <p>Manual do Operador</p>  <p><a href="http://www.algqr.com/tbp">www.algqr.com/tbp</a></p>	<p><b>⚠ GEFAHR</b></p> <p>Falls Sie Deutsch nicht lesen können: Lassen Sie sich, bevor Sie das Gerät in Betrieb nehmen, die Sicherheitshinweise von einer geeigneten Person in Ihre Sprache übersetzen. Oder suchen Sie auf unserer Website nach Übersetzungen von Schilderaufschriften und Sicherheitshinweisen.</p> <p>Benutzerhandbuch</p>  <p>D836 <a href="http://www.algqr.com/tbg">www.algqr.com/tbg</a></p>

**⚠ WARNING**

**PRESSURIZED TANK OIL FILLER CAP IS PRESSURE RELIEF CAP**

**TO AVOID SERIOUS INJURY AND DEATH FROM HOT OIL:**

- STAY AWAY from hot oil that may spray out of tank.
- ALLOW oil to cool down BEFORE removing cap.
- SLOWLY remove cap to relieve pressure BEFORE removing completely.



02971123

# SAFETY

<b>⚠ WARNING</b>		<b>⚠ ADVERTENCIA</b>	
<b>PINCH POINT HAZARD</b>		<b>RIESGO DE PUNTOS DE PELLIZCO</b>	
<b>TO AVOID SERIOUS INJURY:</b> <ul style="list-style-type: none"> <li>• DO NOT OPERATE with Belt Shield removed.</li> </ul>		<b>PARA EVITAR LESION SERIA:</b> <ul style="list-style-type: none"> <li>• NO OPERE con la cubierta de correa ausente.</li> </ul>	
<small>00758194</small>			

<b>⚠ DANGER</b>		<b>⚠ PELIGRO</b>	
<b>Crushing Hazard - Injury or Death</b>		<b>Riesgo de Aplastamiento Lesion o Muerte</b>	
<b>TO AVOID SERIOUS INJURY OR DEATH:</b> <ul style="list-style-type: none"> <li>• STAND CLEAR when removing transport latch, lowering or raising wings.</li> <li>• CLEAR AREA of bystanders before lowering implement wings.</li> <li>• IMPLEMENT CAN FALL from hydraulic failure or accidental operation of controls.</li> <li>• BLOCK UP and securely support equipment before putting hands, feet or body under raised equipment or lifted components.</li> <li>• SECURELY ENGAGE transport latch before transportation or working under wing.</li> <li>• FILL CYLINDERS with oil before attempting to lower implement wings.</li> <li>• DO NOT OPERATE in transport position or with wings off ground.</li> </ul>		<b>PARA EVITAR LESION SERIA O MUERTE:</b> <ul style="list-style-type: none"> <li>• MANTENGASE LEJOS al quitar el cierre de transporte, bajando y devantando las alas.</li> <li>• DESOCUPE EL AREA de personas presentes antes de bajar las alas del implemento.</li> <li>• EL IMPLEMENTO PUEDE CAER del fracaso hidráulico o por operación accidental de controles.</li> <li>• BLOQUEE y soporte con seguridad antes de poner manos, pies o cuerpo debajo del equipo de componentes levantados.</li> <li>• CON SEGURIDAD ACTIVE el cierre de transporte antes de la transportacion o trabajar debajo de las alas.</li> <li>• LLENE LOS CILINDROS con aceite antes de intentar de bajar las alas del implemento.</li> <li>• NO OPERE en posicion de transporte o con las alas devantadas del la tierra.</li> </ul>	
		<small>D698</small>	

# SAFETY

SAFETY

<b>⚠ DANGER</b>		<b>⚠ PELIGRO</b>
<b>THROWN OBJECT HAZARD</b>	 <p>Rubber Deflector Deflector de Hule</p>	<b>RIESGO DE OBJETOS LANZADOS</b>
<p><b>TO AVOID SERIOUS INJURY OR DEATH:</b> DO NOT OPERATE if Thrown Object Shielding is damaged or missing.</p> <ul style="list-style-type: none"> <li>● Maintain Rubber Deflectors in good condition.</li> <li>● Inspect Rubber Deflectors frequently.</li> </ul>		<p><b>PARA EVITAR LESION SERIA O MUERTE:</b> NO OPERE si la Cubierta de Objetos Lanzados esta dañada o falta.</p> <ul style="list-style-type: none"> <li>● Mantenga Los Deflectores de Hule en buenas condiciones.</li> <li>● Inspeccione Los Deflectores de Hule con frecuencia.</li> </ul>

24028

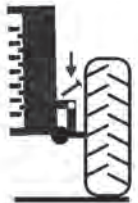
	<b>⚠ DANGER</b>
	Crushing Hazard
	Transport Latch
	RAISE AND SECURELY LOCK Wing Transport Latch before transporting mower on roadways or working under wing.
	<b>⚠ PELIGRO</b>
	Riesgo de Aplastamiento <span style="float: right;">D703</span>
	Cierre de Transporte
	LEVANTE Y DE FORMA SEGURA ATRANQUE el cierre de ala de transporte antes de transportarel cortacéspedes en carretera o trabajando abajo de la ala.

# SAFETY

## Federal Laws and Regulations

This section is intended to explain in broad terms the concept and effect of federal laws and regulations concerning employer and employee equipment operators. This section is not intended as a legal interpretation of the law and should not be considered as such.

### Employer-Employee Operator Regulations

U.S. Public Law 91-596 (The Williams-Steiger Occupational and Health Act of 1970) OSHA

#### This Act Seeks:

"...to assure so far as possible every working man and woman in the nation safe and healthful working conditions and to preserve our human resources..."

#### DUTIES

Sec. 5 (a) Each employer-

(1) shall furnish to each of his employees employment and a place of employment which are free from recognized hazards that are causing or are likely to cause death or serious physical harm to his employees;

(2) shall comply with occupational safety and health standards promulgated under this Act.

(b) Each employee shall comply with occupational safety and health standards and all rules, regulations and orders issued pursuant to this Act which are applicable to his own actions and conduct.

### OSHA Training Requirements

**Title 29, Code of Federal Regulations Part 1928.57(a)(6).** [www.osha.gov](http://www.osha.gov)

Operator instructions. At the time of initial assignment and at least annually thereafter, the employer shall instruct every employee who operates an agricultural tractor and implements in the safe operating practices and servicing of equipment with which they are or will be involved, and of any other practices dictated by the work environment.

Keep all guards in place when the machine is in operation;

Permit no riders on equipment

Stop engine, disconnect the power source, and wait for all machine movement to stop before servicing, adjusting, cleaning or unclogging the equipment, except where the machine must be running to be properly serviced or maintained, in which case the employer shall instruct employees as to all steps and procedures which are necessary to safely service or maintain the equipment.

Make sure everyone is clear of machinery before starting the engine, engaging power, or operating the machine.

### Employer Responsibilities:

To ensure employee safety during Tractor and Implement operation, it is the employer's responsibility to:

1. Train the employee in the proper and safe operation of the Tractor and Implement.
2. Require that the employee read and fully understand the Tractor and Implement Operator's manual.
3. Permit only qualified and properly trained employees to operate the Tractor and Implement.
4. Maintain the Tractor and Implement in a safe operational condition and maintain all shields and guards on the equipment.
5. Ensure the Tractor is equipped with a functional ROPS and seat belt and require that the employee operator securely fasten the safety belt and operate with the ROPS in the raised position at all times.
6. Forbid the employee operator to carry additional riders on the Tractor or Implement.
7. Provide the required tools to maintain the Tractor and Implement in a good safe working condition and provide the necessary support devices to secure the equipment safely while performing repairs and service.
8. Require that the employee operator stop operation if bystanders or passersby come within 300 feet.

### Child Labor Under 16 Years of Age

Some regulations specify that no one under the age of 16 may operate power machinery. It is your responsibility to know what these regulations are in your own area or situation. (Refer to U.S. Dept. of Labor, Employment Standard Administration, Wage & Home Division, Child Labor Bulletin #102.)

# SAFETY

SAFETY

*Safety Section 1-24*

# ASSEMBLY SECTION

*Assembly Section 2-1*

# ASSEMBLY

**Before attempting to mount your Tiger mower, it is important to read and understand all of the safety messages in the Safety Section of this manual.**

Check complete shipment list against the packing list to make sure there are no shortages. Make certain the tractor model is the appropriate one for the mower received!



**WARNING** Always use a floor jack, hoist or fork lift to lift and raise heavy parts.

Read and understand the entire Assembly Section instructions before attempting to mount your Tiger mower. Refer to the Parts Section of this manual for detailed illustrations to locate all parts.

**The Tiger Triple Pull Flail (TPF) requires hookup to the tractor draw bar and 1,000 rpm rear PTO. The rear 3-point hitch arms can interfere with the drive shaft to the TPF. Therefore, prior to hookup of the TPF, remove the lower 3-point arms and lift struts. Then adjust the draw bar on the tractor for 1,000 rpm, 1-3/8-21 spline PTO output shaft (centerline of draw bar pin hole to end of PTO output shaft at approximately 16 inches.) Then attach clevis of tongue to draw bar of tractor and secure using included pin.**



# ASSEMBLY

## MOWER ATTACHMENT

The mower unit attaches to the tractor's hitch using a hitch pin and safety chains. The PTO drive shaft (Tiger Part #00791764) runs from the PTO on the tractor to the mower unit. The wire harness runs from the tractor's rear plug through the harness guide on the mower unit.

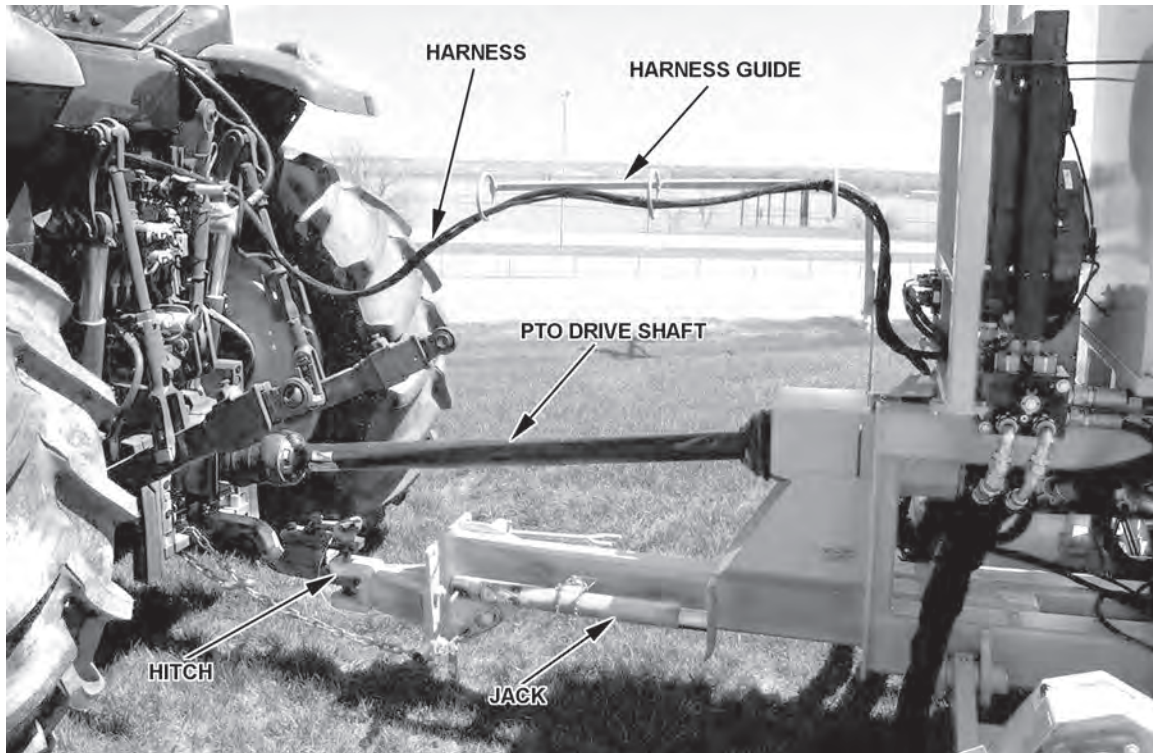

# ASSEMBLY

## CONTINUOUS DUTY SOLENOID

The solenoid should be located close to the tractor's battery or battery access. The solenoid can be mounted using bracket #06411085, 1/4"x1" and 5/16" x1" bolts, nuts and washers. Additional information showing the routing of wire harness #06510320 can be found in the Parts Section.

ASSEMBLY

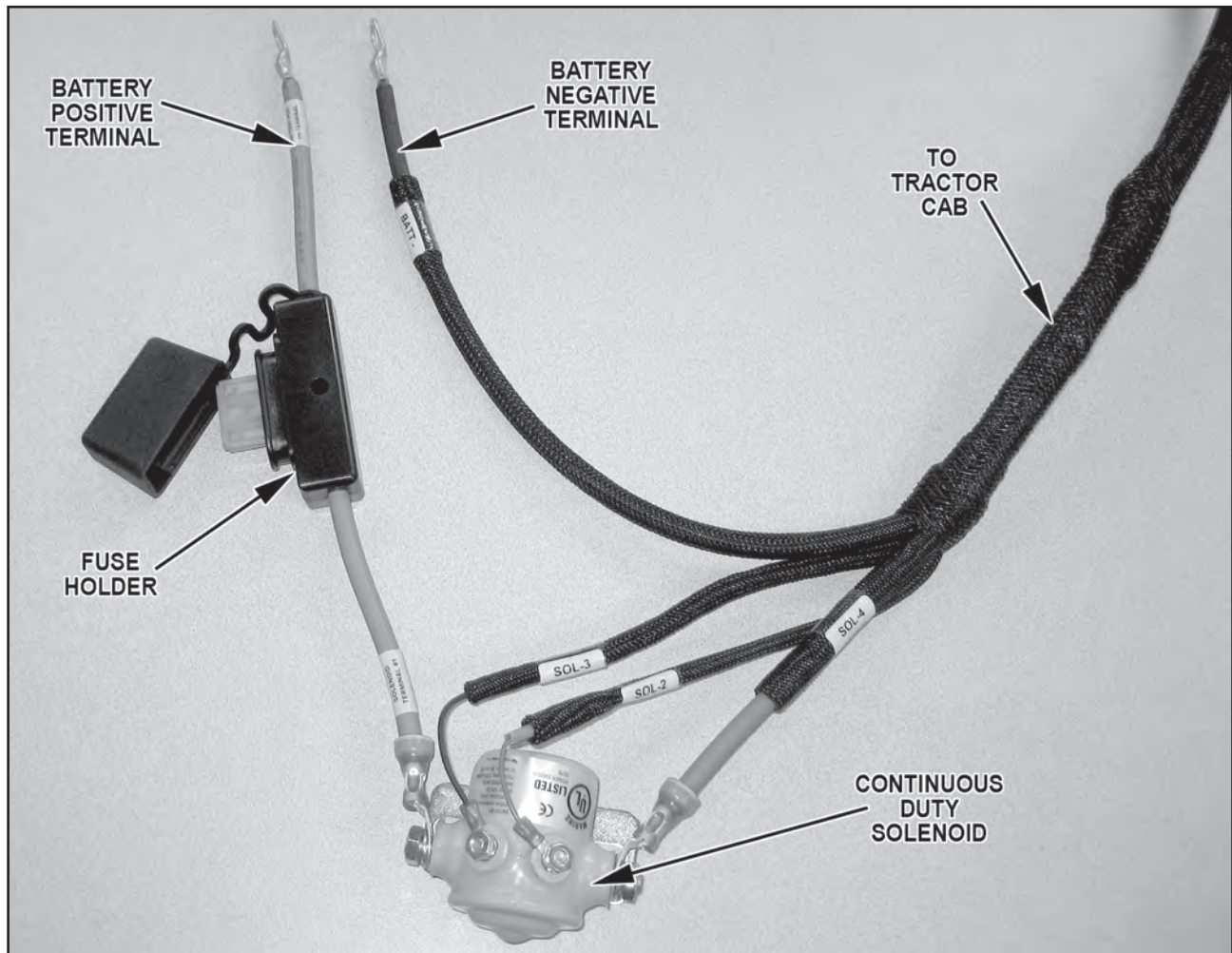

# ASSEMBLY

## HARNESS ROUTING - TRACTOR

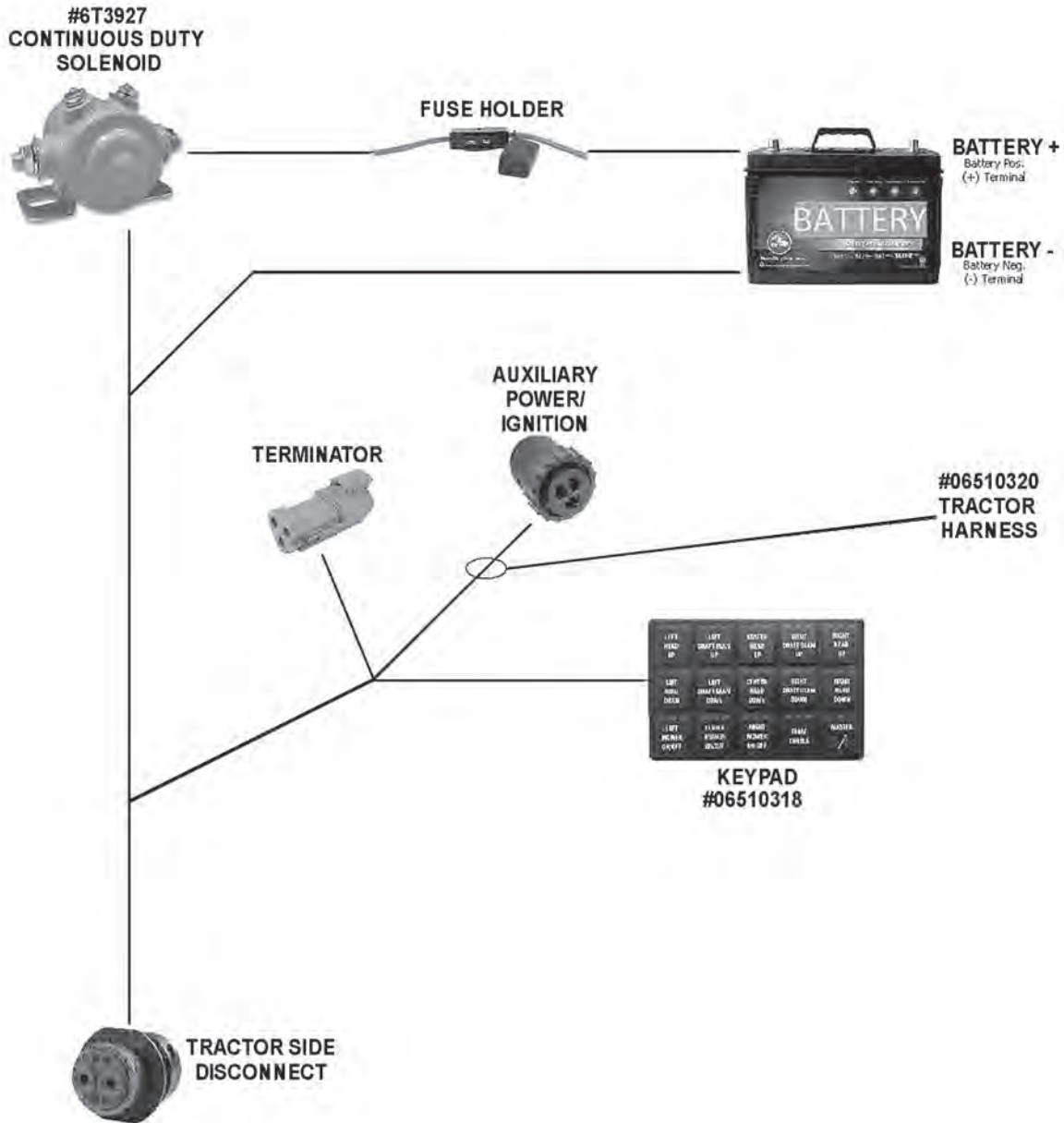

ASSEMBLY

# ASSEMBLY

ASSEMBLY

## HARNESS ROUTING - TRAILER

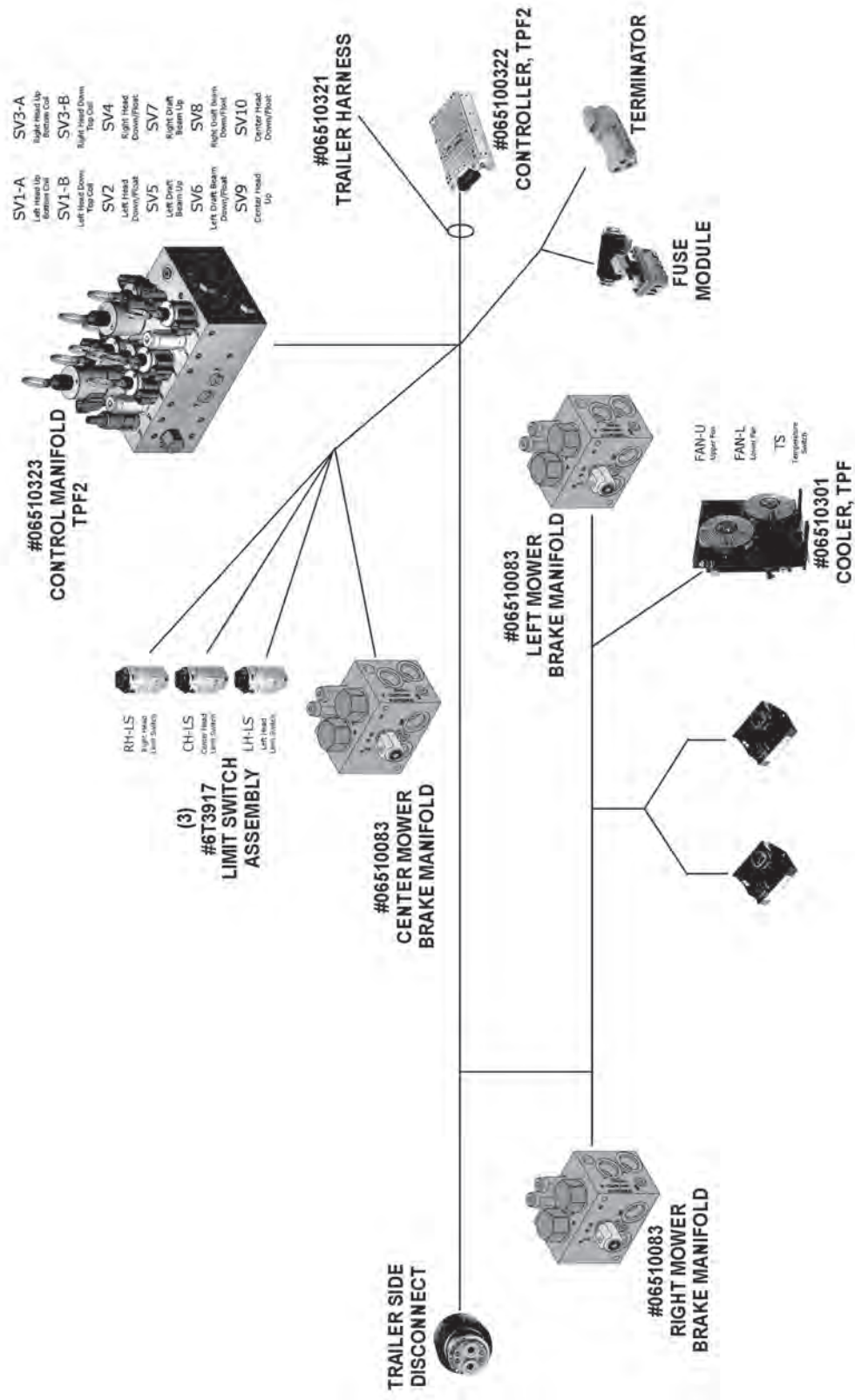

# ASSEMBLY

## KEYPAD INSTALLATION

The Tiger Triple Threat mower functions are controlled with keypad (Tiger #06510318). The keypad can be mounted to the armrest of the driver's seat as shown in the photo below, using the keypad armrest mount (Tiger #06370284) and the hook and loop strap (Tiger #06499024) provided. Connect the keypad harness to the power plug in the rear of the tractor cab. **Detailed instructions on the use of the keypad functions are included in the Operations Section of this manual.**

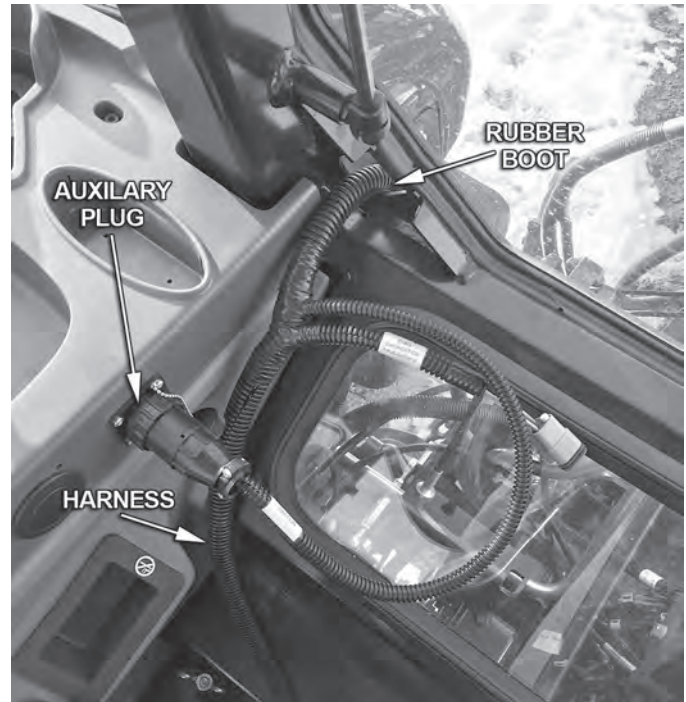

# ASSEMBLY

## HYDRAULIC DIAGRAM

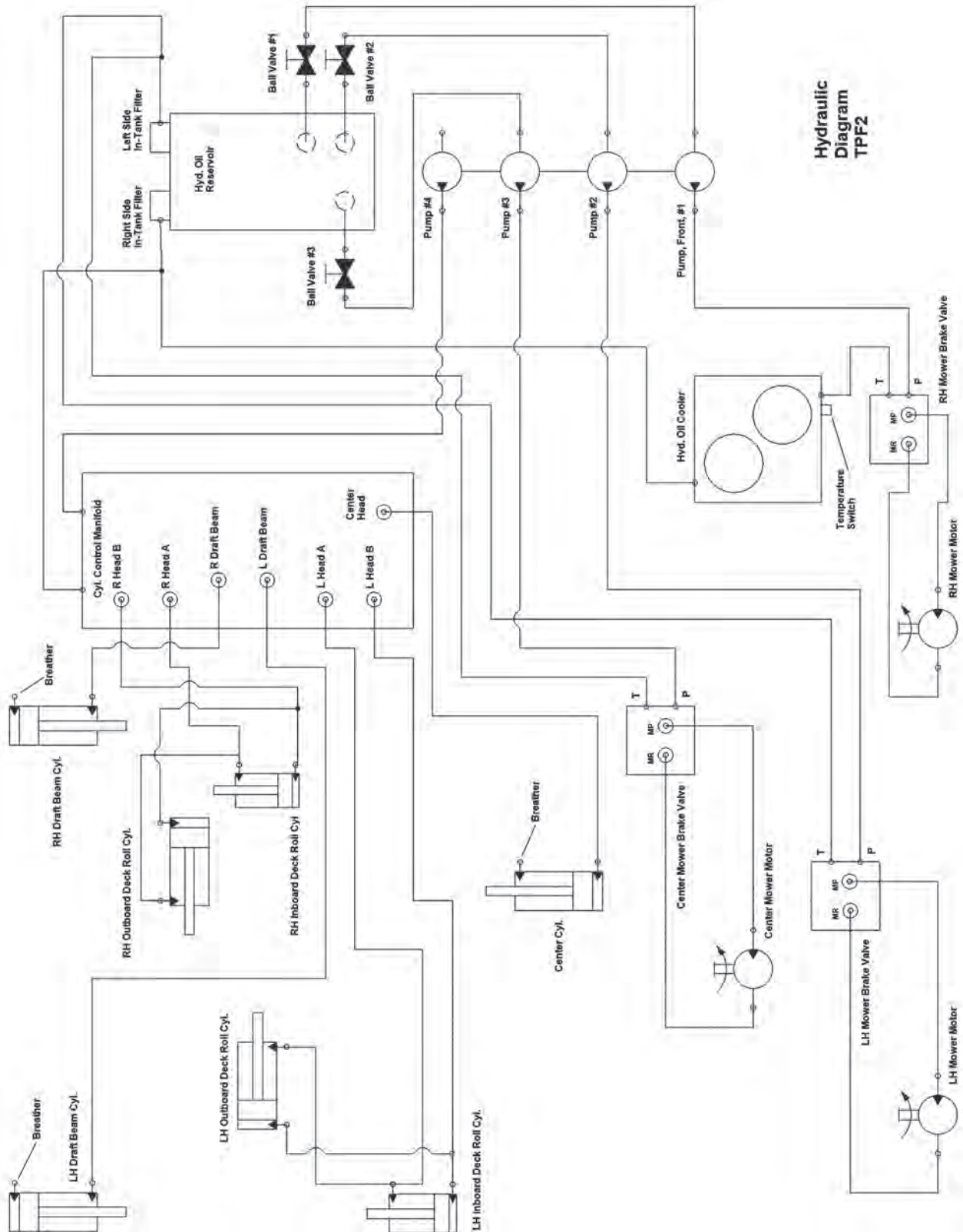

Hydraulic Diagram TPF2

# ASSEMBLY

## TRACTOR 3-POINT ARMS

To prevent potential interference when using the mower, Tiger recommends that the 3-point arms be removed or secured in an upright position before using the triple flail mower.



# ASSEMBLY

## LIMIT SWITCHES

The side and rear mower limit switches (Tiger #6T3917) are installed as shown in the diagram below.

Adjust the switch by loosening the switch arm mount screw. As the follower rises the switch will click off and the arm mount screw can be tightened again.

### WIRING THE SWITCH

Remove the top cover to expose terminals. Connect red wire to either of the back terminals, and the black wire to the other back terminal. Cut the white wire to solenoid valve at a place closest to the tilt-angle switch. Connect the red wire to one of the cut ends and black wire to the other end. This connects the switch in series with the solenoid valve.

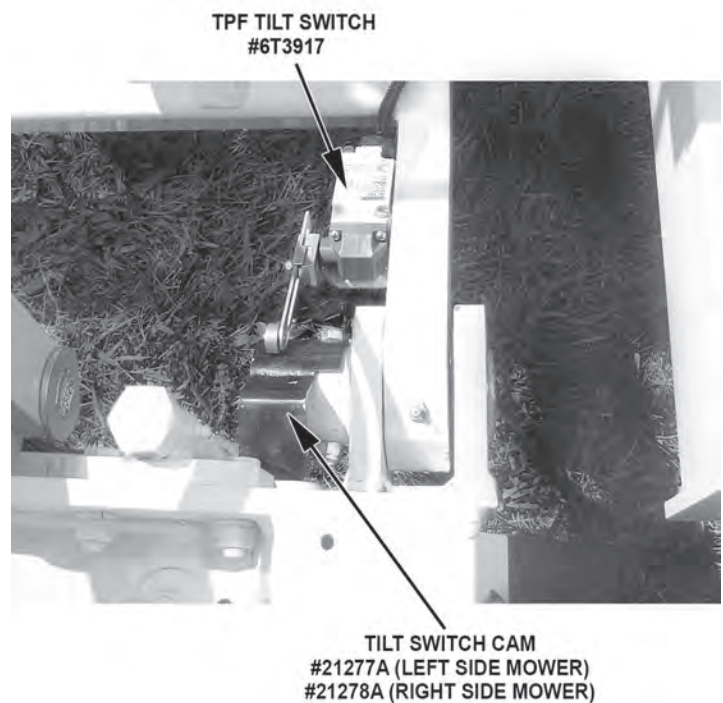
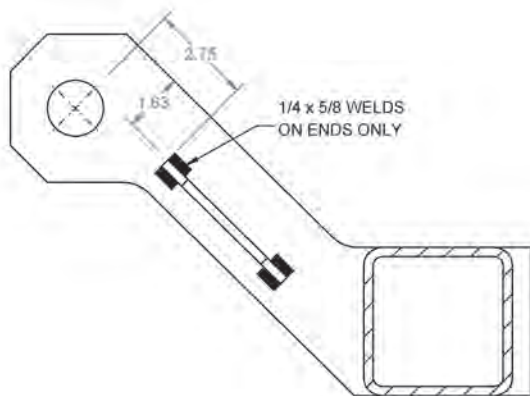
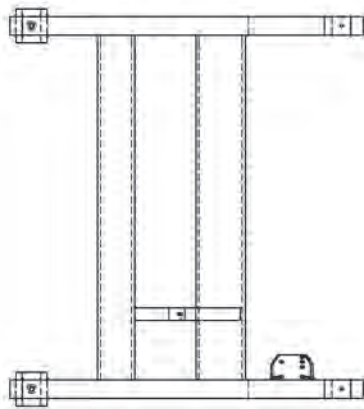



# ASSEMBLY

## DECK/MOTOR FEEDLINE

Install the 1" hoses from the motor to the solenoid valve. Refer to the Parts Section for detailed information about hoses and fittings for this application.

Install split hoses around hydraulic hoses where they contact sharp edges, or any other edges that may rub hoses.

Be sure that all grease zerks are installed in the draft beam pin bosses. Grease all areas of the draft beam according to the instructions in the Maintenance Section. Re-check all fittings for tightness.

Fill hydraulic tank with fluid as recommended in the Maintenance Section. **BE SURE TO OPEN THE BALL VALVES.** Start the tractor and operate the inboard cylinder through the entire stroke and the outboard cylinder through the bottom 3/4 stroke repeatedly to clear the lines of air. **DO NOT run outboard cylinder out to full stroke until stop bolt has been adjusted!**

Check for oil leaks at all fittings and connections using a piece of paper or cardboard. If a leak is found, you must shut down the tractor and set the cutter head on the ground. Before attempting to fix the leak, you must actuate the lift valve handles several times to relieve any pressure in the lines. **DO NOT USE HANDS TO CHECK FOR FLUID LEAKS!**

# ASSEMBLY

## FINAL PREPARATION FOR OPERATION

Place operator's safety and operation decals on the steering column and side console where they are clearly visible to the operator. These decals should be understood by each operator of the machine in conjunction with the Safety and Operation Sections of this book. The decals are to be maintained in good condition as a reminder to the operator, and should be replaced if damaged.

All bosses, pins and pivot points will need to be greased as instructed in the Maintenance Section of this manual. The hydraulic reservoir can also be filled with the recommended fluid (see Maintenance Section) and the filter installed in the top of the tank. Double check all fittings and fasteners BEFORE starting tractor. Also secure any loose hoses together with zip ties and wrap with split hoses where friction may occur on the hoses.



**BEFORE** starting or operating the tractor you must read and understand the Safety and Operation Sections of this manual completely.

**BE SURE THE BALL VALVES ARE OPEN!** Start tractor and allow instruments to stabilize. Using a piece of paper or cardboard as noted in the Safety and Maintenance Sections, check all fittings and connections for hydraulic leaks.

If a leak is found, you must shut down the tractor and set the cutter on the ground. Before attempting to fix the leak, you must actuate the lift valve handles several times to relieve any pressure in the lines.

**Before operating the mower**, the cutter head and boom should be slowly moved throughout the full range of motion. Watch for any condition that would cause pinching or excess stress on the hoses. The steering and front axle travel should also be carefully moved through their full range of motion. If any condition occurs in which the hoses contact the tires, the steering and / or front axle travel may need to be limited as described in the tractor operator's manual. This should also be done if the tires rub, or are extremely close to any other part of the mower, such as the hydraulic tank or draft beam. This may include adding shims or adjusting stop bolts in the tractor front to solve the problem. While checking motion, you should also check that the control circuits are connected according to the operator's decal for the valve handles.

## MOWER TESTING

Take the tractor to a place free of loose objects on the ground. Operate the cylinders through their full range of motion again, to clear the lines of air. Follow the instructions in the Operation Section to operate the mower. Vibration of the mower should be minimal at all times. After a 5 minute test run, the knife bolts should be retorqued, and retorqued once again after the first few hours of operation.

**If any parts of this Assembly Section, or any other section of this manual are not clearly understood you must contact your dealer or the address on the front of this manual for assistance!**

# OPERATION SECTION

*Operation Section 3-1*

# OPERATION

## TIGER TRIPLE PULL BEHIND FLAIL MOWER OPERATING INSTRUCTIONS

Tiger triple pull behind flail mowers are manufactured with quality material by skilled workers. These mowers are designed for cutting grass and small weeds. The mower is equipped with protective deflectors to prevent objects being thrown from the mower by the blades, however, no shielding is 100% effective. All shields, guards, and deflectors equipped on the mower must be maintained in good operational condition.

It is the operator's responsibility to be knowledgeable of all potential operating hazards and to take every reasonable precaution to ensure oneself, others, animals, and property are not injured or damaged by the mower, tractor, or a thrown object. Do not operate the mower if passersby, pets, livestock, or property are within 100 yards of the unit.

This section of the Operator's Manual is designed to familiarize, instruct, and educate safe and proper mower use to the operator. Pictures contained in this section are intended to be used as a visual aid to assist in, explaining the operation of a Triple flail mower and are not specific to any model. Some pictures may show shields removed for picture clarity. NEVER operate implement without all shields in place and in good operational condition. The operator must be familiar with the mower and tractor and all associated safety practices before operating the mower and tractor. Proper operation of the mower, as detailed in this manual, will help ensure years of safe and satisfactory use of the mower.

**IMPORTANT:** To avoid mower damage, retorque all bolts after the first 10 hours of operation. Refer to the Torque Chart at the end of the Maintenance Section to ensure bolts are properly tightened.

**READ AND UNDERSTAND THE ENTIRE OPERATING INSTRUCTIONS AND SAFETY SECTION OF THIS MANUAL AND THE TRACTOR MANUAL BEFORE ATTEMPTING TO USE THE TRACTOR AND IMPLEMENT.** If you do not understand any of the instructions, contact your nearest authorized dealer for a full explanation. Pay close attention to all safety signs and safety messages contained in this manual and those affixed to the implement and tractor.

READ, UNDERSTAND, and FOLLOW the following Safety Messages. Serious injury or death may occur unless care is taken to follow the warnings and instructions stated in the Safety Messages. Always use good common sense to avoid hazards.

**SAFETY  
INSTRUCTIONS**



**PELIGRO**

Si no lee ingles, pida ayuda a alguien que si lo lea para que le traduzca las medidas de seguridad.

**¡ LEA EL  
INSTRUCTIVO!**



# OPERATION

## 1. OPERATOR REQUIREMENTS

Safe operation of the unit is the responsibility of a qualified operator. A qualified operator has read and understands the implement and tractor Operator's Manuals and is experienced in implement and tractor operation and all associated safety practices. In addition to the safety messages contained in this manual, safety signs are affixed to the implement and tractor. If any part of the operation and safe use of this equipment is not completely understood, consult an authorized dealer for a complete explanation.

If the operator cannot read the manuals for themselves or does not completely understand the operation of the equipment, it is the responsibility of the supervisor to read and explain the manuals, safety practices, and operating instructions to the operator.

Safe operation of equipment requires that the operator wear approved Personal Protective Equipment (PPE) for the job conditions when attaching, operating, servicing, and repairing the equipment. PPE is designed to provide operator protection and includes the following safety wear:

### PERSONAL PROTECTIVE EQUIPMENT (PPE)

- Always Wear Safety Glasses
- Hard Hat
- Steel Toe Safety Footwear
- Gloves
- Hearing Protection
- Close Fitting Clothing
- Respirator or Filter Mask (depends on operating conditions)

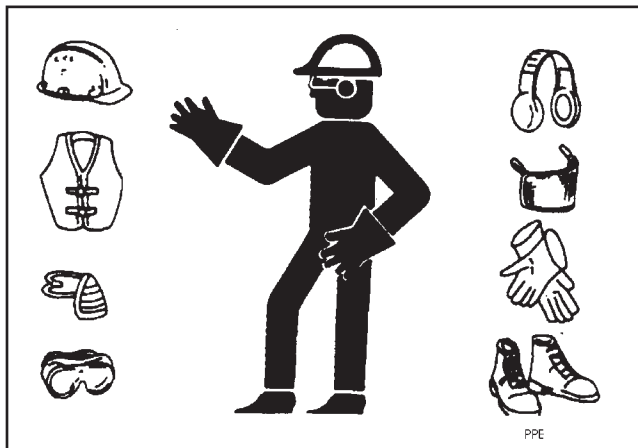

### **⚠ DANGER**

NEVER use drugs or alcohol immediately before or while operating the Tractor and Implement. Drugs and alcohol will affect an operator's alertness and coordination and therefore affect the operator's ability to operate the equipment safely. Before operating the Tractor or Implement, an operator on prescription or over-the-counter medication must consult a medical professional regarding any side effects of the medication that would hinder their ability to operate the Equipment safely. NEVER knowingly allow anyone to operate this equipment when their alertness or coordination is impaired. Serious injury or death to the operator or others could result if the operator is under the influence of drugs or alcohol.

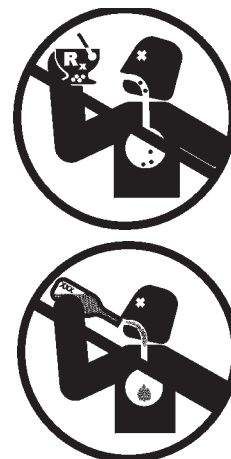

# OPERATION

OPERATION

## 2. TRACTOR REQUIREMENTS

In addition to tractor horsepower and size required to operate the unit, the tractor must also be properly equipped to provide operator protection, to alert approaching vehicle drivers of the tractor's presence, and to ensure tractor stability when mowing.

### **Tractor Requirements and Capabilities**

- ASABE approved Roll-Over Protective Structure (ROPS) or ROPS cab and seat belt.
- Tractor Safety Devices ..... Slow Moving Vehicle (SMV) emblem, lighting, PTO master shield
- Tractor Horsepower..... 85 HP Min Recommended
- Power Take Off..... 1000 RPM

### 2.1 ROPS and Seat Belt

The tractor must be equipped with a Roll-Over-Protective-Structure (ROPS) (tractor cab or roll-bar) and seat belt to protect the operator from falling off the tractor, especially during a roll over where the driver could be crushed and killed. Only operate the tractor with the ROPS in the raised position and seat belt fastened. Tractor models not equipped with a ROPS and seat belt should have these life saving features installed by an authorized dealer.



Operate this Equipment only with a Tractor equipped with an approved rollover-protective system (ROPS). Always wear seat belts. Serious injury or even death could result from falling off the tractor--particularly during a turnover when the operator could be pinned under the ROPS.



### 2.2 Tractor Safety Devices

If transporting or operating the tractor and implement near a public roadway, the tractor must be equipped with proper warning lighting and a Slow Moving Vehicle (SMV) emblem which are clearly visible from the rear of the unit. Lights and a SMV emblem must be equipped directly on implements if the visibility of the tractor warning signals are obscured.

Maintain all manufacturer equipped safety shields and guards. Always replace shields and guards that were removed for access to connect, service, or repair the tractor or implement. Never operate the tractor PTO with the PTO master shield missing or in the raised position.

### 2.3 Tractor Horsepower

The horsepower required to operate the mower depends on many factors including the vegetation to be cut, terrain condition, operator experience, and condition of the mower and tractor. For most mowing condition, the Triple Flail mowers require a tractor with at least 85HP. Operating the mower with a tractor that does not have adequate power may damage the tractor engine.

# OPERATION

## **⚠ DANGER**

DO NOT use a PTO adapter to attach a non-matching Implement driveline to a Tractor PTO. Use of an adapter can double the operating speed of the Implement resulting in excessive vibration, thrown objects, and blade and implement failure. Adapter use will also change the working length of the driveline exposing unshielded driveline areas. Serious bodily injury and/or equipment failure can result from using a PTO adapter. Consult an authorized dealer for assistance if the Implement driveline does not match the Tractor PTO.

## **⚠ WARNING**

For non-independent PTO tractors - Never operate the Tractor and Mower if the Implement input driveline is directly connected to the Tractor transmission. Tractor braking distances can be substantially increased by the momentum of the rotating Mower blades driving the Tractor transmission even though the Tractor clutch has been disengaged. Install an over running clutch between the Tractor PTO and the Mower driveline to prevent this potentially dangerous situation.

## **3. GETTING ON AND OFF THE TRACTOR**

Before getting onto the tractor, the operator must read and completely understand the implement and tractor operator manuals. If any part of either manual is not completely understood, consult an authorized dealer for a complete explanation.

## **⚠ WARNING**

Do not mount or dismount the Tractor while the tractor is moving. Mount the Tractor only when the Tractor and all moving parts are completely stopped.



### **3.1 Boarding the Tractor**

Use both hands and equipped handrails and steps for support when boarding the tractor. Never use control levers for support when mounting the tractor. Seat yourself in the operator's seat and secure the seat belt around you.

Never allow passengers to ride on the tractor or attached equipment. Riders can easily fall off and be seriously injured or killed from falling off and being run over. It is the operator's responsibility to forbid all extra riders at all times.

## **⚠ DANGER**

Never allow children to operate, ride on, or come close to the Tractor or Implement. Usually, 16-17 year-old children who are mature and responsible can operate the implement with adult supervision, if they have read and understand the Operator's Manuals, been trained in proper operation of the tractor and Implement, and are physically large enough to reach and operate the controls easily.



# OPERATION

## **⚠ DANGER**

Never allow children or other persons to ride on the Tractor or Implement. Falling off can result in serious injury or death.



## **⚠ WARNING**

Do not mount or dismount the Tractor while the tractor is moving. Mount the Tractor only when the Tractor and all moving parts are completely stopped.



OPERATION

### **3.2 Dismounting the Tractor**

Before dismounting the tractor, idle the tractor engine down, disengage the head and raise the side mower to the transport position. Park the tractor on a level surface, place the transmission in neutral and set the parking brake. Shut down the tractor engine, remove the key, and wait for all motion to come to a complete stop before exiting the operator's seat. NEVER leave the seat until the tractor, its engine, and mower head movement have come to a complete stop.

Use hand rails and extra steps when exiting the tractor. Be careful of your step and use extra caution when mud, ice, snow, and other matter has accumulated on the steps and handrails. Never rush or jump off the tractor.

## **⚠ DANGER**

BEFORE leaving the tractor seat, always set the parking brake and/or set the tractor transmission in parking gear, disengage the PTO, stop the engine, remove the key, and wait for all moving parts to stop. Place the tractor shift lever into a low range or parking gear to prevent the tractor from rolling. Never dismount a Tractor that is moving or while the engine is running. Operate the Tractor controls from the tractor seat only.

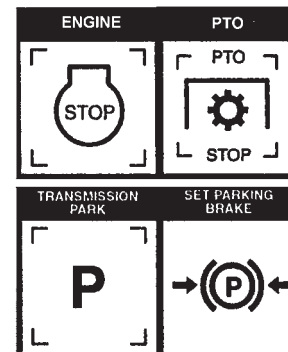



# OPERATION

## 4. STARTING THE TRACTOR

The operator must have a complete understanding of the placement, function, and operational use of all tractor controls before starting the tractor. Review the tractor operator's manual and consult an authorized dealer for tractor operation instructions if needed.

Essential Tractor Controls:

- Locate the ignition key/switch
- Locate the engine shut off control
- Locate the hydraulic control levers
- Locate the light control lever
- Locate the brake pedals and clutch
- Locate the PTO control
- Locate the 3 point hitch control lever
- Locate the operating controls

Before starting the tractor ensure the following:

- Conduct all pre-start operation inspection and service according to the tractor operator's manual.
- Make sure all guards, shields, and other safety devices are securely in place.
- The parking brake is on.
- The tractor transmission levers are in park or neutral.
- The mower operating controls are in the neutral and off position.
- The PTO control lever is disengaged.
- The hydraulic remote control levers are in the neutral position.

Refer to the tractor owner's manual for tractor starting procedures. Only start the tractor while seated and belted in the tractor operator's seat. Never bypass the ignition switch by short circuiting the starter solenoid. After the tractor engine is running, avoid accidental contact with the tractor transmission to prevent sudden and unexpected tractor movement.

**⚠ DANGER** Never run the Tractor engine in a closed building or without adequate ventilation. The exhaust fumes can be hazardous to your health.

**⚠ DANGER** Start tractor only when properly seated in the Tractor seat. Starting a tractor in gear can result in injury or death. Read the Tractor operator's manual for proper starting instructions.



## 5. CONNECTING THE MOWER TO THE TRACTOR

Use extreme caution when connecting the mower to the tractor. The mower should be securely resting at ground level or setting on blocks. Keep hands and feet from under the mower deck and clear of pinch points between the tractor hitch arms and mower pins.

# OPERATION

## **⚠ DANGER**

Always shut the Tractor completely down, place the transmission in park, and set the parking brake before you or anyone else attempts to connect or disconnect the Implement and Tractor hitches.

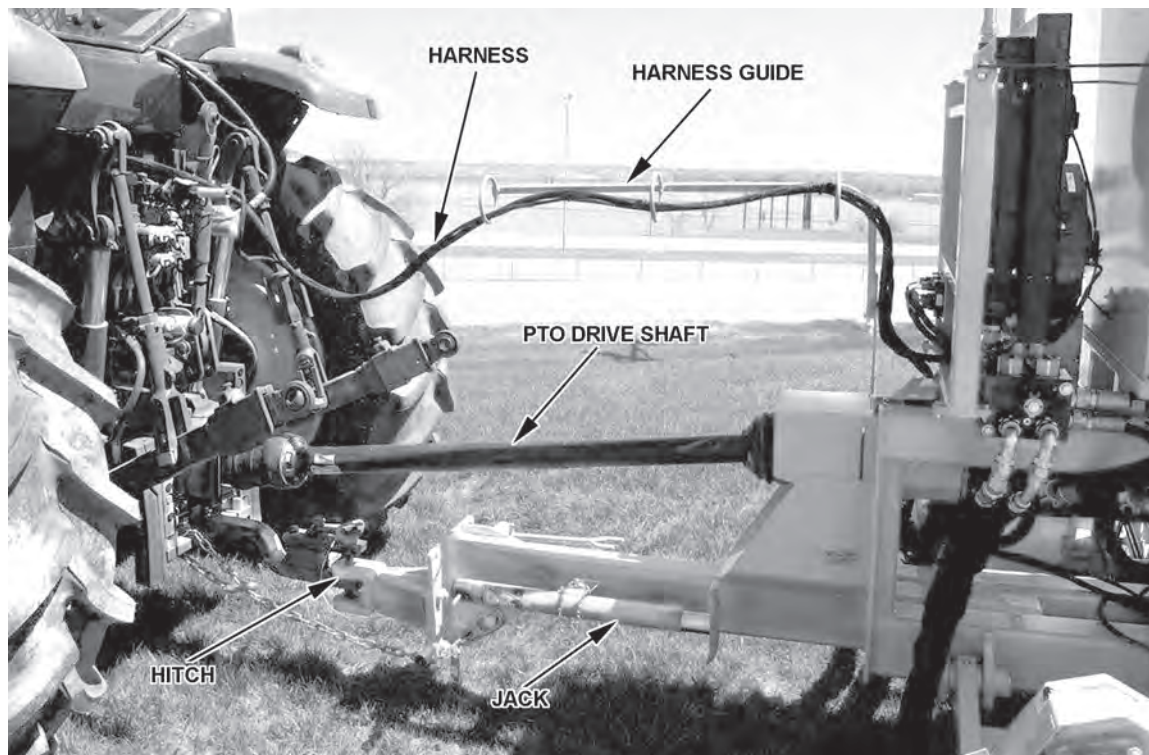

OPERATION

## **5.1 Attaching the mower**

Make sure the tractor is equipped with the correct PTO shaft. Change shafts if necessary. Line up the tractor hitch with the tongue of the TPF mower. Attach with pin # -----. Attach chains

Electrical harness from tractor to mower should be routed through the hose guide.

Photos:

PTO: Triple Pull Flail 5-04-18 (57)

Harnesses: Triple Pull Flail 5-04-18 (59)

# OPERATION

## **⚠ WARNING**

Do not operate this Equipment with hydraulic oil or fuel leaking. Oil and fuel are explosive and their presence could present a hazard. Do not check for leaks with your hand! High-pressure oil streams from breaks in the line could penetrate the skin and cause tissue damage including gangrene. To check for a hose leak, SHUT the unit ENGINE OFF and remove all hydraulic pressure. Wear oil impenetrable gloves, safety glasses and use Cardboard to check for evidence of oil leaks. If you suspect a leak, REMOVE the HOSE and have it tested at a Dealer. If oil does penetrate the skin, have the injury treated immediately by a physician knowledgeable and skilled in this procedure.



## **⚠ WARNING**

Avoid contact with hot surfaces including hydraulic oil tanks, pumps, motors, valves and hose connections. Relieve hydraulic pressure before performing maintenance or repairs. Use gloves and eye protection when servicing hot components. Contact with a hot surface or fluid can cause serious injury from burns or scalding.

## **⚠ DANGER**

DO NOT allow any person under a side mower unless mower is securely locked up or supported. DO NOT approach the Implement unless the Tractor is turned off and all motion has ceased. Never work under the frame work, or any lifted component unless the implement is securely supported or blocked up. A sudden or inadvertent fall by any of these components could cause serious injury or even death.



# OPERATION

## 6. SETTING THE MOWER

Properly setting the cutting height is essential for efficient and safe operation. A properly set mower will make a more uniform cut, distribute clippings more evenly, require minimal tractor work, and follow the contour of uneven terrain. **NOTE:** Avoid very low cutting heights, striking the ground with the blades gives the most damaging shock loads and will cause damage to the mower and drive. Blades contacting the ground may cause objects to be thrown out from under the mower deck. Always avoid operating the mower at a height which causes the blades to contact the ground.



Never work under the Implement, the framework, or any lifted component unless the Implement is securely supported or blocked up to prevent sudden or inadvertent falling which could cause serious injury or even death.



### 6.1 Roller Height Adjustment

1. The mower's cutting height is set by positioning the roller assembly for each mower section. Each section must be set at the same height to ensure an even cut across the entire width of the mower.
2. Place the tractor and mower on a level surface and completely lower the mower to the ground.
3. Shut down the tractor, place the transmission in park, and set the parking brake before dismounting.
4. One section at a time, place lifting device (scissors jack or hydraulic jack) under center of cutter housing.
5. Remove hex nuts, washers and carriage bolts from brackets at each end of roller. Make certain that roller bracket is free to move once the fasteners are removed. A stuck roller could drop unexpectedly and cause injury.
6. For Standard Duty flails, use lifting device to reposition cutter housing to desired cutting height. Align bracket holes with cutter housing, then reinstall hardware.
7. For Heavy Duty flails, loosen the Adjustment rod lock nut and adjust height by turning the Adjustment Rod. Retighten the Adjustment rod lock nut and then reinstall hardware.
8. Lower cutter housing to the ground and remove lifting device.
9. Set cutting height according to procedures above for remaining two cutter sections. Make sure that all three rollers are set at the same height to ensure a even cut across the entire width of the mower.

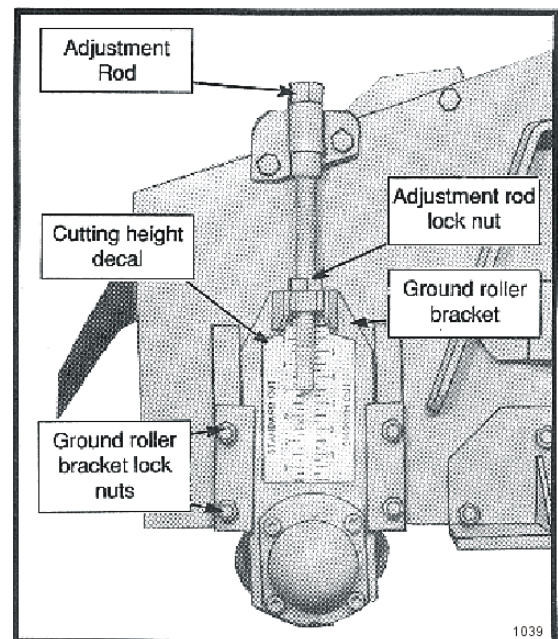

# OPERATION

## **WARNING**

Do not let the Blades turn when the Mower Deck is raised for any reason, including clearance or for turning. Raising the Mower deck exposes the Cutting Blades which creates a potentially serious hazard and could cause serious injury or even death from objects thrown from the Blades.



## **7. DRIVELINE ATTACHMENT**

The driveline yoke and tractor PTO shaft must be dirt free and greased for attachment.

To connect the mower driveline to the tractor PTO output shaft, pull the driveline yoke collar back and align the grooves and splines of the yoke with those of the PTO shaft. Push the driveline yoke onto the PTO shaft, release the locking collar, and position the yoke until the locking collar balls are seated onto the PTO shaft. Push and pull the driveline back and forth several times to ensure a secure attachment.



After the driveline is securely attached, place the tractor PTO master shield back in the operating position.

## **WARNING**

Before operating the Implement, check to make sure the Implement input driveline will not bottom out or become disengaged. Bottoming out occurs when the inner shaft penetrates the outer housing until the assembly becomes solid--it can shorten no more. Bottoming out can cause serious damage to the Tractor PTO by pushing the PTO into the Tractor and through the support bearings or downward onto the PTO shaft, breaking it off. A broken driveline can cause personal injury.

# OPERATION

## 8. PRE-OPERATION INSPECTION AND SERVICE

Before each use, a pre-operation inspection and service of the implement and tractor must be performed. This includes routine maintenance and scheduled lubrication, inspecting that all safety devices are equipped and functional, and performing needed repairs. DO NOT operate the unit if the pre-operation inspection reveals any condition affecting safe operation. Perform repairs and replacement of damaged and missing parts as soon as noticed. By performing a thorough pre-operation inspection and service, valuable down time and repair cost can be avoided.

**⚠ DANGER**

Always disconnect the main PTO Driveline from the Tractor before performing service on the Mower. Never work on the Mower with the tractor PTO driveline connected and running. Blades or Drivelines could turn without warning and cause immediate entanglement, injury or death.

**⚠ DANGER**

DO NOT allow any person under a side mower unless mower is securely locked up or supported. DO NOT approach the Implement unless the Tractor is turned off and all motion has ceased. Never work under the frame work, or any lifted component unless the implement is securely supported or blocked up. A sudden or inadvertent fall by any of these components could cause serious injury or even death.

**⚠ WARNING**

Periodically inspect all moving parts for wear and replace when necessary with authorized service parts. Look for loose fasteners, worn or broken parts, and leaky or loose fittings. Make sure all pins have attaching hardware. Serious injury may occur from not maintaining this machine in good working order.



# OPERATION

## **8.1 Tractor Pre-Operation Inspection/Service**

Refer to the tractor operator's manual to ensure a complete pre-operation inspection and scheduled service is performed according to the manufacturers' recommendations. The following are some of the items that require daily service and inspection:

- Tire condition/air pressure
- Wheel lug bolts
- Steering linkage
- PTO shield
- SMV sign is clean and visible
- Tractor's lights are clean and functional
- Tractor Seat belt is in good condition
- Tractor ROPS is in good condition
- ROPS is in the raised position
- No tractor oil leaks
- Radiator free of debris
- Engine oil level and condition
- Engine coolant level and condition
- Power brake fluid level
- Power steering fluid level
- Fuel condition and level
- Sufficient lubrication at all lube points
- Air filter condition OPS-U-0030



## **8.2 Mower Pre-Operation Inspection/Service**

Before each mower use, a complete inspection and service is required to ensure the mower is in a good and safe working condition. Damaged and/or broken parts should be repaired and/or replaced immediately. To ensure the mower is ready for operation, conduct the following. OPS-R-0007



All Safety Shields, Guards and Safety devices including (but not limited to) - the Deflectors, Steel Guards, Gearbox Shields, PTO integral shields, and Retractable Door Shields should be used and maintained in good working condition. All safety devices should be inspected carefully at least daily for missing or broken components. Missing, broken, or worn items must be replaced at once to reduce the possibility of injury or death from thrown objects, entanglement, or blade contact.

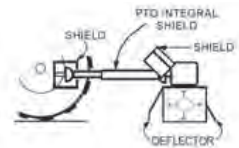

Replace bent or broken blades with new blades. NEVER ATTEMPT TO STRAIGHTEN, WELD, OR WELD HARDFACING ON BLADES SINCE THIS WILL LIKELY CRACK OR OTHERWISE DAMAGE THE BLADE WITH SUBSEQUENT FAILURE AND POSSIBLY CAUSE SERIOUS INJURY FROM THROWN BLADES.

# OPERATION

The operator's manual and safety signs affixed on the unit contain important instructions on the safe and proper use of the equipment. Maintain these important safety features on the implement in good condition to ensure the information is available to the operator at all times.

- Ensure all safety signs are in place and legible. Replace missing, damaged, and illegible decals.



- Check that the main driveline is securely attached to the tractor and the locking collar is seated in the groove of the PTO Shaft.
- Ensure side mower hydraulics are secure at both ends.



- Ensure rubber deflectors are in position and not damaged. Replace worn, broken, and missing sections immediately.
- Ensure the rollers are in good condition and rotate freely.
- Ensure the driveline integral shield is in good condition and rotate freely.
- Inspect that all bolts and screws are in position and are properly torqued.





# OPERATION

- Inspect the condition of the side mowers and rear mower drive belts.
- Ensure the slip clutch shield and drive belts shields are in place and in good repair.
- Ensure the tractor PTO master shield is in place, lowered and in good condition.



- Inspect cutter knives and knife pins for looseness and excessive wear. Make sure the mower is securely blocked up before crawling beneath. Replace damaged, worn, and missing knives as complete sets to maintain cuttershaft balance.
- Remove any grass or other debris which may be wrapped around the cuttershafts.
- Inspect the condition of deck skid shoes and hardware.



# OPERATION

## Tractor PRE-OPERATION Inspection



Mower ID# \_\_\_\_\_

Make \_\_\_\_\_

Date: \_\_\_\_\_

Shift \_\_\_\_\_



Before conducting the inspection, make sure the tractor engine is off, all rotation has stopped and the tractor is in park with the parking brake engaged. Make sure the mower is resting on the ground or securely blocked up and all hydraulic pressure has been relieved.

OPERATION

Item	Condition at Start of Shift	Specific Comments if not O.K.
The flashing lights function properly		
The SMV Sign is clean and visible		
The tires are in good condition with proper pressure		
The wheel lug bolts are tight		
The tractor brakes are in good condition		
The steering linkage is in good condition		
There are no visible oil leaks		
The hydraulic controls function properly		
The ROPS or ROBS Cab is in good condition		
The seatbelt is in place and in good condition		
The 3-point hitch is in good condition		
The drawbar pins are securely in place		
The PTO master shield is in place		
The engine oil level is full		
The brake fluid level is full		
The power steering fluid level is full		
The fuel level is adequate		
The engine coolant fluid level is full		
The radiator is free of debris		
The air filter is in good condition		

Operator's Signature: \_\_\_\_\_

**DO NOT OPERATE an UNSAFE TRACTOR or MOWER**

This Inspection Form may be freely duplicated for extra copies.

# OPERATION

## Flail Mower PRE-OPERATION Inspection



Mower ID# \_\_\_\_\_

Make \_\_\_\_\_

Date: \_\_\_\_\_

Shift \_\_\_\_\_



Before conducting the inspection, make sure the tractor engine is off, all rotation has stopped and the tractor is in park with the parking brake engaged. Make sure the mower is resting on the ground or securely blocked up and all hydraulic pressure has been relieved.

Item	Condition at Start of Shift	Specific Comments if not O.K.
The Operator's Manual is in the tractor		
All safety decals are in place and legible		
The mounting frame bolts are in place and tight		
The connection bolts & pins are tight		
There are no cracks in mower		
The hydraulic cylinders pins are tight		
The hydraulic pump hose connections are tight		
The hydraulic valve controls function properly		
There are no leaking or damaged hoses		
The hydraulic oil level is full		
There is no evidence of hydraulic leaks		
The blades are not chipped, cracked or bent		
The blade bolts are tight		
The deflectors are in place and in good condition		
The shields are in place and in good condition		
The skid shoes are in good condition and tight		
There are no cracks or holes in boom deck		
The hydraulic motor mounting bolts are tight		

Operator's Signature: \_\_\_\_\_

**DO NOT OPERATE an UNSAFE TRACTOR or MOWER**

This Inspection Form may be freely duplicated for extra copies.

**OPERATION**

# OPERATION

## 9. DRIVING THE TRACTOR AND IMPLEMENT

Safe tractor transport requires the operator possess a thorough knowledge of the model being operated and precautions to take while driving with an attached implement. Ensure the tractor has the capacity to handle the weight of the implement and the tractor operating controls are set for safe transport. To ensure safety while driving the tractor with an attached implement, review the following.

### **▲ DANGER**

This Implement may be wider than the Tractor. Be careful when operating or transporting this equipment to prevent the Implement from running into or striking sign posts, guard rails, concrete abutments or other solid objects. Such an impact could cause the Implement and Tractor to pivot violently resulting in loss of steering control, serious injury, or even death. Never allow the Implement to contact obstacles.

### **▲ WARNING**

Transport only at speeds where you can maintain control of the equipment. Serious accidents and injuries can result from operating this equipment at high speeds. Understand the Tractor and Implement and how it handles before transporting on streets and highways. Make sure the Tractor steering and brakes are in good condition and operate properly.



Before transporting the Tractor and Implement, determine the proper transport speeds for you and the equipment. Make sure you abide by the following rules:

Test the tractor at a slow speed and increase the speed slowly. Apply the Brakes smoothly to determine the stopping characteristics of the Tractor and Implement. As you increase the speed of the Tractor the stopping distance increases. Determine the maximum transport speed not to exceed 20 mph (30 kph) for transporting this equipment.

Test the equipment at a slow speed in turns. Increase the speed through the turn only after you determine that the equipment can be operated at a higher speed. Use extreme care and reduce your speed when turning sharply to prevent the tractor and implement from turning over. Determine the maximum turning speed for you and this equipment before operating on roads or uneven ground.

Only transport the Tractor and Implement at the speeds which allow you to properly control the equipment.

Be aware of the operating conditions. Do not operate the Tractor with weak or faulty brakes or worn tires. When operating down a hill or on wet or rain slick roads, the braking distance increases: use extreme care and reduce your speed. When operating in traffic always use the Tractor's flashing warning lights and reduce your speed. Be aware of traffic around you and watch out for the other guy.



# OPERATION

## **9.1 Starting the Tractor**

The procedure to start the tractor is model specific. Refer to the tractor operator's manual for starting procedures for your particular tractor. Consult an authorized dealer if the starting procedure is unclear. Ensure the 3-point control lever is in the lowered position and the PTO is disengaged before starting the tractor.



## **9.2 Brake and Differential Lock Setting**

Make sure the tractor brakes are in good operating condition. Tractor brakes can be set to operate independently allowing single rear wheel braking action or locked together to provide simultaneous rear wheel braking. FOR MOST DRIVING AND OPERATING CONDITIONS, THE BRAKE PEDALS SHOULD BE LOCKED TOGETHER TO PROVIDE THE MOST EFFECTIVE BRAKING ACTION.

Always disengage the tractor differential lock when turning. When engaged the differential lock will prevent or limit the tractor from turning. During normal cutting conditions, locking the differential provides no benefit and should not be used.

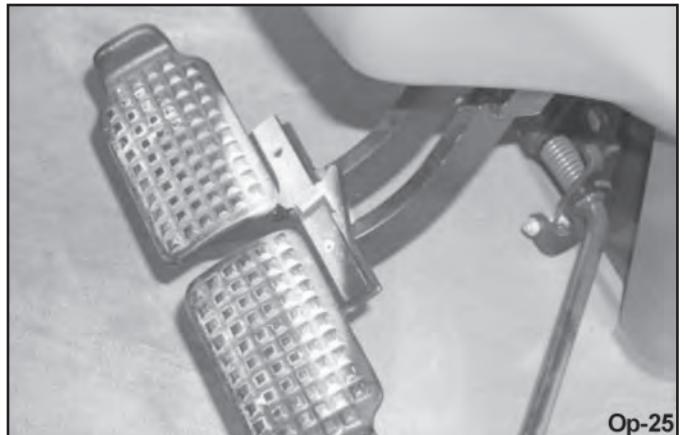

# OPERATION

## **9.3 Transport Position**

When the side mowers are folded for transport, the center of gravity is raised and the possibility of overturn is increased. Drive slowly and use extreme caution when turning on hillsides. Overturning the Implement could cause the Implement to overturn the Tractor and vice-versa resulting in serious injury or even death. Never fold side mowers on a hillside--the Implement or unit may overturn.



## **9.4 Operating Position**

The mower must be operated with the cutter sections fully lowered and float active to ensure the mower follows the contour of the ground and to prevent sections from creeping up. NEVER attempt to raise the mower while the mower is operating.

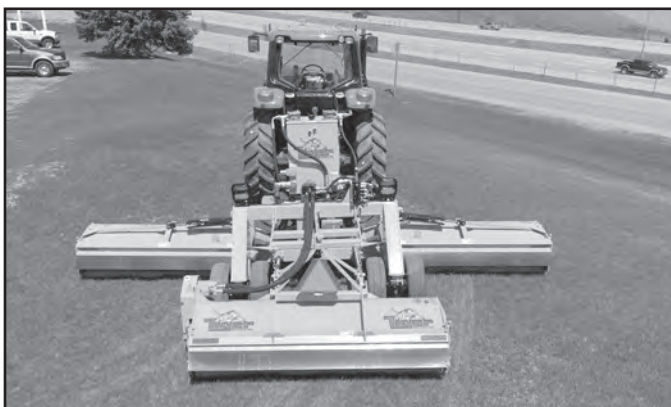

# OPERATION

## **9.5 Driving the Tractor and Implements**

Start off driving at a slow speed and gradually increase your speed while maintaining complete control of the tractor and units. Moving slowly at first will also prevent the tractor from rearing up and loss of steering control. The tractor should never be operated at speeds that cannot be safely handled or which will prevent the operator from stopping quickly during an emergency. If the power steering or engine ceases operating, stop the tractor immediately as the tractor will be difficult to control.

Perform turns with the tractor and units at slow speeds to determine how the tractor with an attached mower handles a turn. Determine the safe speed to maintain proper control of the tractor when making turns.

To avoid overturns, drive the tractor with care and at safe speeds, especially when operating over rough ground, crossing ditches or slopes, and turning corners. Tractor wheel tread spacing should be increased when working on inclines or rough ground to reduce the possibility of tipping. Use extreme caution when operating on steep slopes. Keep the tractor in a low gear when going downhill. **DO NOT** coast or free-wheel downhill.



# OPERATION

## 9.6 Crossing Ditches and Steep Inclines

When crossing ditches with steep banks or going up sharp inclines, it is possible that the main driveline inner profile will penetrate into the outer housing to its maximum depth until the assembly becomes solid (driveline is at its extreme shortest length). This type of abusive operation can cause serious damage to the tractor and mower drive by pushing the PTO into the tractor and through the support bearings or downward onto the PTO shaft, breaking it off.

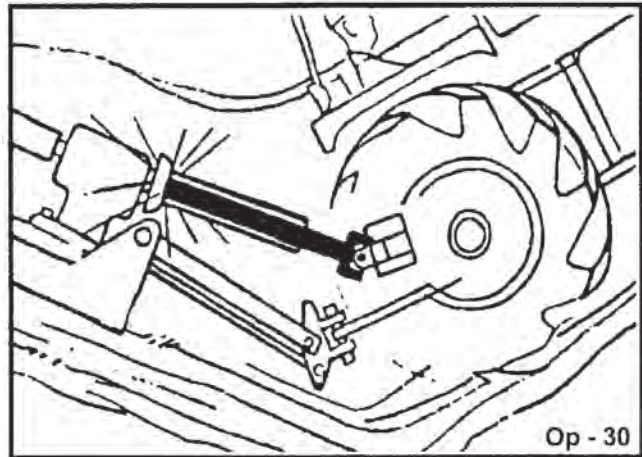

### **WARNING**

Damage resulting from over-collapse of the driveline's inner profile and its outer housing may allow the driveline to come loose from the Tractor which could cause bodily injury to the operator or bystanders and/or extensive damage to the Tractor or Implement.

When confronted with an incline or ditch, do not approach from an angle which is perpendicular or straight on as damage to or collapse of the driveline may occur.

When crossing such terrain, the implement should be fully lowered for a lower center of gravity and added stability.

Inclines and ditches should be approached along a line which is at an angle as shown. This type of path will reduce the possibility of over-collapse of the driveline and resulting damage. If the gradient is so steep that such an approach increases the possibility of a tractor roll-over, select an alternate crossing path.

When operating the tractor and mower across slopes and inclines, through ditches, and other uneven terrain conditions, it is important to maintain sufficient deck to ground clearance. Blade contact with the ground may cause soil, rocks and other debris to be thrown out from under the mower resulting in possible injury and/or property damage. Ground contact also produces a severe shock load on the mower drive and to the mower blades resulting in possible damage and premature wear.

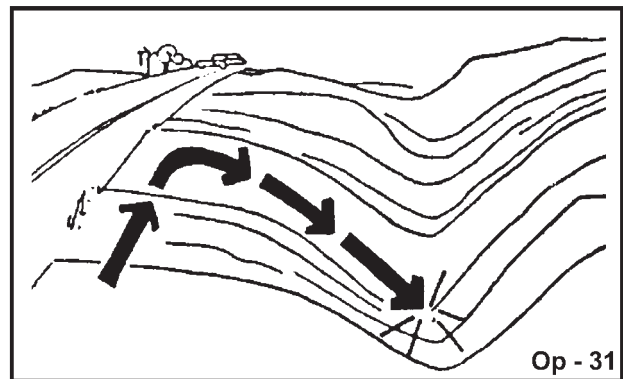

**INCORRECT: DO NOT** approach ditch straight on

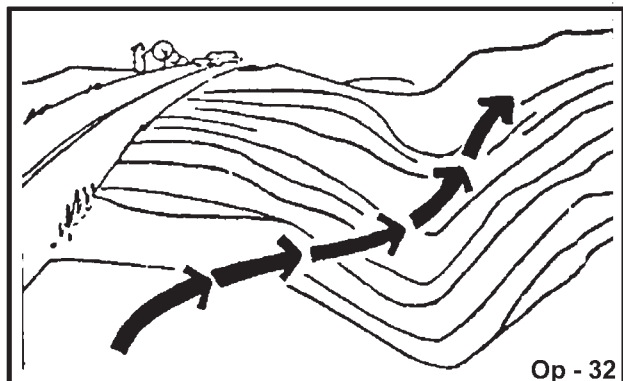

**CORRECT: Approach ditch at an angle**



# OPERATION

## 10. OPERATING THE TRACTOR AND IMPLEMENT

**THE OPERATOR MUST COMPLETELY UNDERSTAND HOW TO OPERATE THE TRACTOR AND IMPLEMENT AND ALL CONTROLS BEFORE ATTEMPTING TO OPERATE.** The operator must read and understand the Safety and Operation Sections of the implement and tractor operator's manuals. These manuals must be read and explained to any operator who cannot read. Never allow someone to operate the implement and tractor without complete operating instructions.

Before starting any operation, the operator must become familiar with the area to be worked in and any obstacles and hazards contained within to ensure safety to the operator, bystanders, and equipment. Special attention should be paid to foreign debris, rough terrain, steep slopes, and passersby and animals in the area.

### **WARNING**

Extreme care should be taken when operating near loose objects such as gravel, rocks, wire, and other debris. Inspect the area before mowing. Foreign objects should be removed from the site to prevent machine damage and/or bodily injury or even death. Any objects that cannot be removed must be clearly marked and carefully avoided by the operator. Stop mowing immediately if blades strike a foreign object. Repair all damage and make certain rotor or blade carrier is balanced before resuming mowing.



### **WARNING**

Many varied objects, such as wire, cable, rope, or chains, can become entangled in the operating parts of the mower head. These items could then swing outside the housing at greater velocities than the blades. Such a situation is extremely hazardous and could result in serious injury or even death. Inspect the cutting area for such objects before mowing. Remove any like object from the site. Never allow the cutting blades to contact such items.

# OPERATION

## **10.1 Foreign Debris Hazards**

Before mowing, inspect the area to make sure there are no foreign objects that the mower blades could hit or become entangled with. Remove all foreign objects and debris. If objects are too big to remove, mark them clearly and be sure to prevent the mower blades from contacting them.

If you hit a solid object or foreign debris, stop the mower and tractor at once. Immediately idle the engine speed and disengage the PTO. Wait for all mower rotating motion to stop, then raise the mower and move the tractor and implement off the object. Inspect the area and remove, or mark the location of the debris. Inspect the condition of the mower and make any needed repairs immediately. Make sure the blades are not damaged and the carrier is balanced before resuming operation.

Always wear your seat belt securely fastened and only operate the tractor and mower with the ROPS in the raised position. If the tractor or mower hits a tree stump, rock, or bump, a sudden movement could throw you off of the seat and under the tractor and/or mower. The seat belt is your best protection from falling off the tractor and the ROPS provides protection from being crushed during a tractor roll-over.



Op - 33



## **10.2 Bystanders/Passersby Precautions**

If a bystander comes within 300 feet of the tractor while the mower is being operated, stop the tractor at once, idle the engine and disengage the PTO. Do not engage the PTO again until all bystanders are well past the 300 foot distance.

# OPERATION

## **⚠ DANGER**

Flail Mowers are capable under adverse conditions of throwing objects for great distances (300 feet or more) and causing serious injury or death. Follow safety messages carefully.



### **STOP MOWING IF PASSERSBY ARE WITHIN 300 FEET UNLESS:**

- Front and Rear Deflectors, Chain Guards, or Bands are installed and in good, workable condition;
- Mower sections are running close to and parallel to the ground without exposed Blades;
- All areas have been thoroughly inspected and all foreign material such as rocks, cans, glass, and general debris has been removed.

**NOTE:** *Where there are grass and weeds high enough to hide debris that could be struck by the blades, the area should be: inspected and large debris removed, mowed at an intermediate height, inspected closely with any remaining debris being removed, and mowed again at desired final height. (This will also reduce power required to mow, reduce wear and tear on the Mower drivetrain, spread cut material better, eliminate streaking, and make the final cut more uniform.)*

### **10.3 Engaging the Power Take Off (PTO)**

Before engaging the PTO, make certain that the area is clear of bystanders and passersby. The implement must be completely lowered and the deck positioned at a safe operating height. NEVER engage the PTO with the implement in the raised position.

Set the tractor engine speed at approximately 1,000 RPM before engaging the PTO. Shift the PTO control to the on position, and slowly increase the engine speed until the PTO is operating at the rated speed. If you hear unusual noises or see or feel abnormal vibrations, disengage the PTO immediately. Inspect the implement to determine the cause of the noise or vibration and repair the abnormality.

## **⚠ WARNING**

Do not let the Blades turn when the Mower Deck is raised for any reason, including clearance or for turning. Raising the Mower deck exposes the Cutting Blades which creates a potentially serious hazard and could cause serious injury or even death from objects thrown from the Blades.



## **⚠ WARNING**

Do not put hands or feet under mower decks. Blade Contact can result in serious injury or even death. Stay away until all motion has stopped and the decks are securely blocked up.



# OPERATION

## **10.4 PTO RPM and Ground Speed**

Ground speed for mowing will depend upon the height, type, and density of vegetation to be cut. Recommended speed for efficient mower performance is between 2 and 5 mph(3-8 kph). Operate the mower at its full rated PTO speed to maintain blade speed for a clean cut. Refer to the tractor operator's manual or the tractor instrument panel for the engine speed and gear to provide the required PTO and desired ground speed. Make sure that the mower is operating at its full rated speed before entering the vegetation to be cut. If it becomes necessary to temporarily regulate engine speed, increase or decrease the throttle gradually.

Ground speed is achieved by transmission gear selection and not by the engine operating speed. The operator may be required to experiment with several gear range combinations to determine the best gear and range which provides the most ideal performance from the mower and most efficient tractor operation. As the severity of cutting conditions increase, the ground speed should be decreased by selecting a lower gear to maintain the proper operating PTO speed.



Do not exceed the rated PTO speed for the Implement. Excessive PTO speeds can cause Implement driveline or blade failures resulting in serious injury or death.



Mow at the speed that you can safely operate and control the tractor and mower. The correct mowing speed depends on terrain condition and grass type, density, and height of cut. Normal ground speed range is from 2 to 5 mph (3-8 kph). Use slow mowing speeds when operating on or near steep slopes, ditches, drop-offs, overhead obstructions, power lines, or when debris and foreign objects are to be avoided.

# OPERATION

## 11. CONTROL LOCATION AND FUNCTIONS

### KEYPAD OPERATION

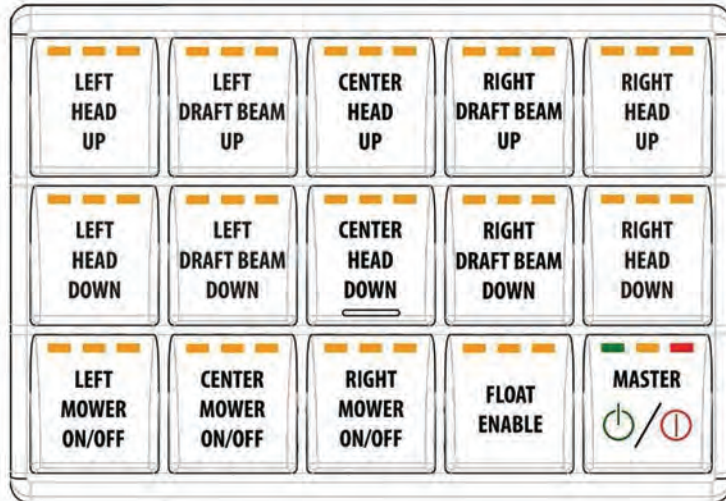

OPERATION

### CONTROL INPUTS – KEYPAD

When the tractor ignition key is OFF, the mower control system is also off. When the ignition key is ON, the keypad, controller, and cooling fan H-Bridge modules have power, but the keypad will not function until the MASTER key is pressed.

### MASTER ON/OFF

The green LED on the MASTER key comes on when the key is pressed, and the keypad inputs and controller outputs become active. Cooling fan operations are active only if the control system is active.

Pressing the MASTER button again will deactivate the system. All hydraulic functions will stop and will not resume until the MASTER button is pressed again. All head and draft beam operations will stop in their current position until the system is re-activated. The ON/OFF keys for each mower (left, center, right) and the FLOAT ENABLE key must be pushed to resume operation.

**With the control system active (green LED on MASTER key is on):**

### LEFT HEAD UP

Pressing the LEFT HEAD UP key will move the left head upward. If the left mower float is enabled, this will deactivate the float function.

### LEFT HEAD DOWN

Pressing the LEFT HEAD DOWN key will move the left head downward. Pressing this key while the left mower float is enabled will have no effect.

### LEFT DRAFT BEAM UP

Pressing the LEFT DRAFT BEAM UP key will move the left draft beam upward. If the left mower float is enabled, this will deactivate the float function.

### LEFT DRAFT BEAM DOWN

Pressing the LEFT DRAFT BEAM DOWN key will move the left draft beam downward. Pressing this key while the left mower float is enabled will have no effect.

# OPERATION

## **CENTER HEAD UP**

Pressing the CENTER HEAD UP key will move the center head upward. If the center mower float is enabled, this will deactivate the float function.

## **CENTER HEAD DOWN**

Pressing the CENTER HEAD DOWN key will move the center head downward. Pressing this button when float is enabled will have no effect.

## **RIGHT DRAFT BEAM UP**

Pressing the RIGHT DRAFT BEAM UP key will move the right draft beam upward. If the right mower float is enabled, this will deactivate the float function.

## **RIGHT DRAFT BEAM DOWN**

Pressing the RIGHT DRAFT BEAM DOWN key will move the right draft beam downward. Pressing this key while the right mower float is enabled has no effect.

## **RIGHT HEAD UP**

Pressing the RIGHT HEAD UP key will move the right head upward. Pressing this key while the right mower float is enabled will deactivate the float function.

## **RIGHT HEAD DOWN**

Pressing the RIGHT HEAD DOWN key will move the right head downward. Pressing this key while the right mower float is enabled has no effect.

## **LEFT MOWER ON/OFF**

When the left mower is off and the left head is high enough to activate the limit switch, all LEDs on the LEFT MOWER ON/OFF key will be off and the mower can't be activated. When the mower is low enough that the limit switch is not activated, the middle LED of the LEFT MOWER ON/OFF key will be on and the mower can be activated.

When the middle LED is on, pressing and holding the LEFT MOWER ON/OFF key will start a sequence of LED lights. The left LED will turn on after .5 seconds, the middle LED will turn on after 1 second, and the right LED will turn on after 1.5 seconds. Once all 3 LEDs are on, release the key and the mower will start. All 3 LEDs on the LEFT MOWER ON/OFF key will be on when the mower is active.

If the mower is on, pressing the LEFT MOWER ON/OFF key will turn it off. Additionally, lifting the head far enough to activate the limit switch will turn the mower off. Pressing the MASTER ON/OFF key will deactivate the system, including the left mower.

## **CENTER MOWER ON/OFF**

When the center mower is off and the center head is high enough to activate the limit switch, all LEDs on the CENTER MOWER ON/OFF key will be off and the mower can't be activated. When the mower is low enough that the limit switch is not activated, the middle LED of the CENTER MOWER ON/OFF key will be on and the mower can be activated.

When the middle LED is on, pressing and holding the CENTER MOWER ON/OFF key will start a sequence of LED lights. The left LED will turn on after .5 seconds, the middle LED will turn on after 1 second, and the right LED will turn on after 1.5 seconds. Once all 3 LEDs are on, release the key and the mower will start. All 3 LEDs on the CENTER MOWER ON/OFF key will be on when the mower is active.

# OPERATION

If the mower is on, pressing the CENTER MOWER ON/OFF key will turn it off. Additionally, lifting the head far enough to activate the limit switch will turn the mower off. Pressing the MASTER ON/OFF key will deactivate the system, including the center mower.

## RIGHT MOWER ON/OFF

When the right mower is off and the right head is high enough to activate the limit switch, all LEDs on the RIGHT MOWER ON/OFF key will be off and the mower can't be activated. When the mower is low enough that the limit switch is not activated, the middle LED will be on and the mower can be activated.

When the middle LED is on, pressing and holding the RIGHT MOWER ON/OFF key will start a sequence of LED lights. The left LED will turn on after .5 seconds, the middle LED will turn on after 1 second, and the right LED will turn on after 1.5 seconds. Once all 3 LEDs are on, release the key and the mower will start. All 3 LEDs on the RIGHT MOWER ON/OFF key will be on when the mower is active.

If the mower is on, pressing the RIGHT MOWER ON/OFF key will turn it off. Additionally, lifting the head far enough to activate the limit switch will turn the mower off. Pressing the MASTER ON/OFF key will deactivate the system, including the right mower.

## FLOAT ENABLE

Pressing the FLOAT ENABLE key activates the float function for any of the three mowers that are not already in float mode and are in an acceptable position. If the center LED on any of the MOWER ON/OFF keys is on and the FLOAT ENABLE key is pressed, float will be enabled for that mower.

- Pressing the HEAD UP or DRAFT BEAM UP key for any of the mowers will disable float mode for that mower.
- Deactivating the control system with the MASTER ON/OFF key will disable float mode for all mowers.
- Turning any mower off by using the MOWER ON/OFF keys will not disable float mode for that mower.

The LED lights on the FLOAT ENABLE key indicate which mowers are currently in float mode. The left LED corresponds to the left mower, the middle LED to the center mower and the right LED to the right mower.

## AUTOMATIC COOLING FAN CONTROL

All cooling fan operations are active only while MASTER ON/OFF is on. However, while the ignition is on, the controller and continuous duty solenoid provide power to the cooling fan H-Bridge modules. Disconnecting the wire harness at the hitch will deactivate the continuous duty solenoid and disconnect power from the controller and cooling fans. The ignition should be turned off prior to disconnecting the mower.

## COOLING CYCLE

When MASTER ON/OFF is active and the hydraulic oil temperature switch has been active for 60 seconds, the cooling fans will turn on and go through an automatic reversing sequence. Both fans will ramp up to full speed reverse over 5 seconds and remain in full speed reverse for 20 seconds to clear debris from the oil cooler, and then ramp down over 5 seconds. After a 5 second pause, the fans will ramp up to full speed forward over 5 seconds. They will remain at full speed forward until the temperature switch has been inactive for 15 seconds, then ramp back down over 5 seconds. The cooling cycle will begin again when the temperature switch has been active for 60 seconds.

If the temperature switch remains active after the fans have been operating in the forward direction for 34 minutes and 55 seconds, the fans will ramp down over 5 seconds and the cooling cycle will repeat (after a 60 second delay) followed by the reversing sequence. This cooling cycle will repeat until the temperature switch becomes inactive. Shutting down the MASTER ON/OFF key or turning off the towing vehicle ignition will deactivate the cooling system even if the temperature switch is still active.

# OPERATION

## MANUAL OVERRIDE OPERATING INSTRUCTIONS

If the Tiger Triple Threat mower's can/electrical system is inoperative the manifold functions can be performed manually. See the instructions below and the illustration on the facing page for more details.

**When operating the manifold manually, stand clear of the right-hand flail head and rear flail head.**

### LEFT DRAFT BEAM UP

Pull on key ring on valve SV5

### LEFT DRAFT BEAM DOWN

Pull on key ring on valve SV6

### LEFT HEAD UP

Push button on top of valve SV1

### LEFT HEAD DOWN

Pull key ring on valve SV1 and pull key ring on valve SV2 simultaneously

### RIGHT DRAFT BEAM UP

Pull on key ring on valve SV7

### RIGHT DRAFT BEAM DOWN

Pull on key ring on valve SV8

### RIGHT HEAD UP

Push button on top of valve SV3

### RIGHT HEAD DOWN

Pull key ring on valve SV3 and pull key ring on valve SV4 simultaneously

### CENTER HEAD UP

Pull on key ring on valve SV9

### CENTER HEAD DOWN

Pull on key ring on valve SV10



# OPERATION

## MANUAL OVERRIDE OPERATING INSTRUCTIONS

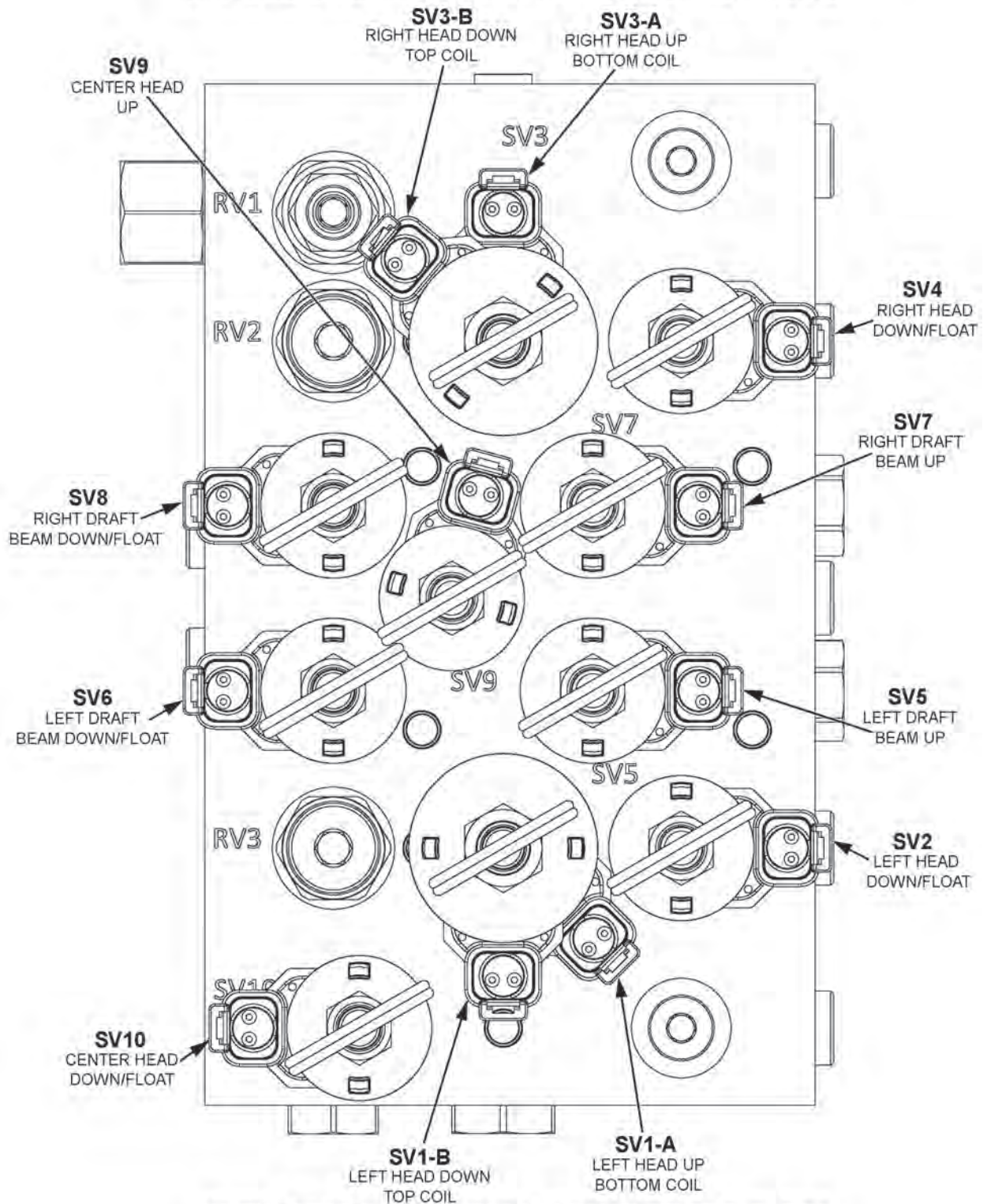

**WHEN OPERATING MANIFOLD MANUALLY, STAND CLEAR OF  
RIGHT HAND FLAIL HEAD AND REAR FLAIL HEAD**

Operation Section 3-31

OPERATION

# OPERATION

## 11.1 Operating the Mower



### WARNING

When rotating parts are in motion, serious injury may occur if caution is not used or danger is not recognized. Never allow bystanders within 300 feet of the machine when in operation. Extreme care should be taken when operating near loose objects – such as gravel, rocks and debris. These conditions should be avoided.

The rotating parts in this machine have been designed and tested for rugged use. However, they could fail upon impact with heavy solid objects – such as steel guard rails, concrete abutments, etc., causing them to be thrown at a very high velocity. Never allow cutter head to contact such objects. Inspecting the cutting area for such objects prior to mowing can help eliminate these potential hazards.

Once on location, lower the mower deck slightly above the material to be cut, so the mower does not have to start under a load. Bring the R.P.M. of the tractor up to 1200 and engage the side mower. If a rear mower is being used, allow the R.P.M. to return to 1200 before engaging the rear mower. The flail mower deck should be carried so that part of the weight is carried by the ground roller. When the flail is carried this way, the roller also follows the contour of the ground more easily during mowing operations.

When cutting small shrubs or brush, begin each pass at the top of the material and work down with each consecutive pass. Use a low speed to allow the cutting blades time to mulch as well as cut the foliage. When the initial pass has been made, disengage the mower and return the mower to the travel position. Return to the starting point and make next pass, etc. The flail head is not intended for cutting heavy brush, or for continually cutting brush. Wear or damage of the blades will occur rapidly when the flail cutter is used this way.

To ensure a clean cut, engine speed should be maintained at approximately 1800 – 2200 R.P.M. If the tractor slows to less than 1800 R.P.M., shift to the next lower gear. **DO NOT** ride the clutch, this will cause premature clutch failure. **The engine should not be operated at any time at more than 2400 R.P.M. on the tractor tachometer.**

The mower will operate more efficiently in tougher conditions and with less power if the knives are kept sharp. If mower begins to vibrate, stop the tractor, check for wire wrapped around the cuttershaft or damaged knives. When replacing knives, replace all knives with new knives to ensure proper balance so the mower will not vibrate. Severe vibration will result, if knives with unequal wear are used. Follow the instructions in the Maintenance Section closely when replacing knife blades.



### WARNING

If bystanders approach within 300 feet while mower is in operation turn mower switch “OFF” immediately! After shutdown, never leave the tractor or allow bystanders to approach within **300 feet** of the unit until all motion stops completely.

# OPERATION

When encountering a very severe condition which causes the tractor to stall, disengage mower, start tractor, raise the mower from the cut. Shut off tractor and inspect the mower, blades and cuttershaft for damage before engaging mower again.

If the blades jam or stop, disengage the clutch and raise the head slightly or back the tractor up. Normally, this will clear the cutter head. If not, shut off the mower(s), raise the cutter heads, turn off the tractor and set the parking brake. After all motion stops completely, leave the tractor and clear the cutting heads manually.

After the first day of operation, all bolts should be checked and tightened securely. This should be done periodically to ensure the bolts do not become loose and cause damage to the tractor or mower, or injury to the operator. Also, be sure to lubricate the unit as instructed in the Maintenance Section.

## **11.2 Shutting Down the Implement**

To shut down the implement, first bring the tractor to a complete stop. Then slow down the implement by reducing the engine speed before disengaging the PTO. Wait for all motion to stop before proceeding to drive or shut down the tractor.



Park the tractor on a level surface, place the transmission in park or neutral and apply the parking brake, lower the attached implement to the ground, shut down the engine, remove the key, and wait for all motion to come to a complete stop before exiting the tractor.

# OPERATION

## 12. DISCONNECTING THE MOWER FROM THE TRACTOR

Before disconnecting the mower, the PTO must be disengaged and all motion at a complete stop. Move the mower to a level storage location and lower both side mowers to the ground. If the mower will be stored with the sections in the raised position, be sure that the travel locks are engaged. If the mower is not resting securely on the ground, block the mower up securely before attempting to disconnect it from the tractor. Use extreme care to keep feet and hands from under the mower and clear of any pinch points.

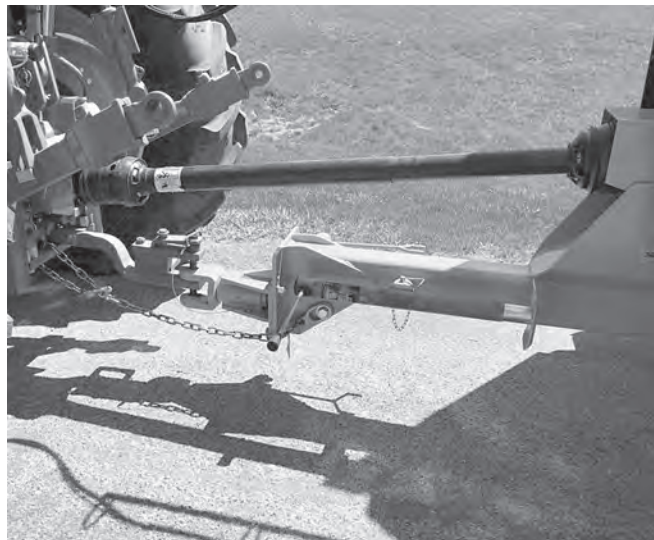

Remove the mower driveline from the tractor PTO shaft. Lay the driveline down carefully to avoid damaging the driveline or its shield. Do not let the driveline fall into mud or dirt, which can contaminate the bearing and shorten the life of the driveline.

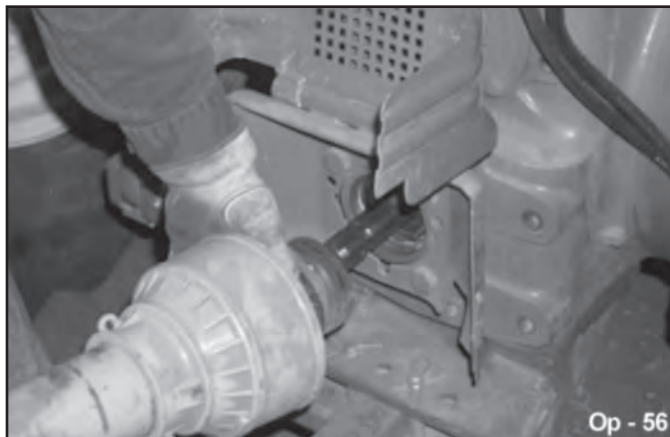

### **⚠ DANGER**

Never work under the Implement, the framework, or any lifted component unless the Implement is securely supported or blocked up to prevent sudden or inadvertent falling which could cause serious injury or even death.



# OPERATION

## **13. MOWER STORAGE**

It is recommended that the mower be stored with the center section and both side mowers fully lowered to ground level. If the mower is stored with the side mowers in the raised position, select a level area and engage travel locks and travel lock pins to prevent the side mowers from falling BEFORE disconnecting the mower rear mower.

Properly preparing and storing the mower at the end of the season is critical to maintaining its appearance and to help ensure years of dependable service. The following are suggested storage procedures:

- Thoroughly clean all debris off the mower to prevent damage from rotting grass and standing water.
- Lubricate all mower grease points and fill gearbox oil levels as detailed in the Maintenance Section.
- Tighten all bolts and pins to the recommended torque.
- Check the mower for worn and damaged parts. Perform repairs and make replacements immediately so that the mower will be ready for use at the start of the next season.
- Store the mower in a clean, dry place with the mower housing resting securely on blocks or at ground level.
- Keep the driveline yoke from sitting in water, dirt and other contaminants.
- Use spray touch-up enamel where necessary to prevent rust and maintain the appearance of the mower.



It is critical that driveline clutches slip when an obstacle or heavy load is encountered to avoid mower and/or tractor damage. If the mower sits outside for an extended period of time or is exposed to rain and/or humid air, the clutch lining plates must be inspected to ensure they are not frozen together from rust or corrosion. If the mower has been exposed to such conditions, at the start of each mowing season, and any time it is suspected that the slip clutch plates may be frozen together, readjust the slip clutch as detailed in Seasonal Clutch Maintenance of the Maintenance Section in this manual.



Never allow children to play on or around Tractor or Implement. Children can slip or fall off the Equipment and be injured or killed. Children can cause the Implement to shift or fall crushing themselves or others.

# OPERATION

## 14. TRANSPORTING THE TRACTOR AND IMPLEMENT

Inherent hazards of operating the tractor and implement and the possibility of accidents are not left behind when you finish working in an area. Therefore, the operator must employ good judgement and safe operation practices when transporting the tractor and implement between locations. By using good judgement and following safe transport procedures, the possibility of accidents while moving between locations can be substantially minimized.



Never allow children or other persons to ride on the Tractor or Implement. Falling off can result in serious injury or death.



OPERATION

Before transporting the tractor and mower, idle the tractor engine, disengage the PTO and wait for all mower moving parts to come to a complete stop. Raise the mower sections and ensure travel locks engage.



# OPERATION

Before transporting the tractor on a public roadway or boarding a trailer for transport, the tractor brake pedals should be locked together. Locking the pedals ensures that both wheels brake simultaneously while stopping, especially when making an emergency stop.

Use extreme caution and avoid hard applications of the tractor brakes when carrying equipment at road speeds. Never haul the implement at speeds greater than 20 MPH (32 kph).

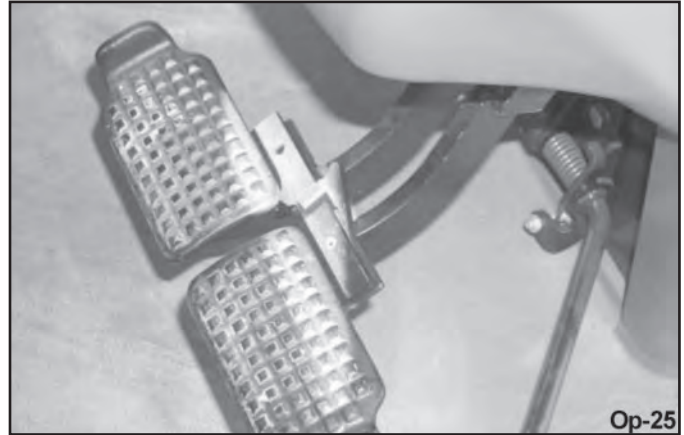

If the tractor's hydraulic pump is not independent of the tractor PTO, or if the tractor PTO has to be run to have hydraulic power, disconnect the mower driveline from the tractor PTO output shaft. Secure the driveline to the mower deck to prevent driveline damage or loss during transport.

## **14.1 Transporting on Public Roadways**

Extreme caution should be used when transporting the tractor and implement on public roadways. The tractor must be equipped with all required safety warning features including a SMV emblem and flashing warning lights to alert drivers of the tractor's presence. Remember that roadways are primarily designed for automotive drivers and most drivers will not be looking out for you, therefore, you must look out for them. Check your side view mirrors frequently and remember that vehicles will approach quickly because of the tractor's slower speed. Be extremely cautious when the piece of equipment that you are carrying is wider than the tractor tire width and/or extends beyond your lane of the road.

**NOTE:** Ensure that the mower sections are fully raised and that the travel locks are engaged for each section.

### **▲ WARNING**

Only carry the Implement behind a properly sized and equipped Tractor which exceeds the weight of the Implement by at least 20%. DO NOT carry the Implement behind a truck or other type of vehicle. Never carry the Implement and another Implement connected in tandem. Never carry the Implement at speeds over 20 MPH.



### **▲ DANGER**

Never allow children or other persons to ride on the Tractor or Implement. Falling off can result in serious injury or death.



# OPERATION

## **WARNING**

Make certain that the “Slow Moving Vehicle” (SMV) sign is installed in such a way as to be clearly visible and legible. When transporting the Equipment use the Tractor flashing warning lights and follow all local traffic regulations.

The SMV (Slow-Moving Vehicle) emblem is universal symbol used to alert drivers of the presence of equipment traveling on roadways at a slow speed. SMV signs are a triangular bright orange with reflective red trim for both easy day and night visibility. Make sure the SMV sign is clean and visible from the rear of the unit before transporting the tractor and implement on a public roadway. Replace the SMV emblem if faded, damaged, or no longer reflective.



The TPF is equipped with DOT approved lights, and it's important to be sure they are functioning properly before proceeding onto public roads. Also, be certain that all tractor flashing warning lights, headlights, and brake/tail lights are in working order. Consult an authorized tractor dealer for lighting kits and modifications available to upgrade the lighting on older tractor models.

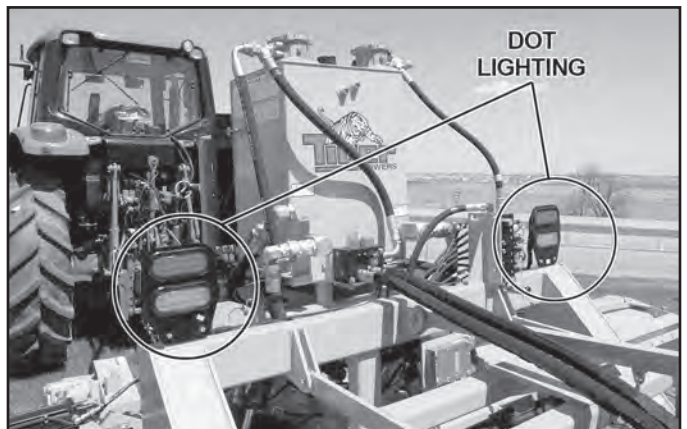

When operating on public roads, have consideration for other road users. Pull to the side of the road occasionally to allow all following traffic to pass. Do not exceed the legal speed limit set in your country for agricultural tractors. Always stay alert when transporting the tractor and implement on public roads. Use caution and reduce speed if other vehicles or pedestrians are in the area.





# OPERATION

Reduce speed before turning or applying the brakes. Ensure that both brake pedals are locked together when operating on public roads.



## **14.2 Hauling the Tractor and Implement**

Before transporting a loaded tractor and implement, measure the height and width dimensions and gross weight of the complete loaded unit. Ensure that the load will be in compliance with the legal limits set for the areas that will be traveled through.

Use adequately sized and rated trailers and equipment to transport the tractor and implement. Consult an authorized dealer to determine the proper equipment required. Using adequately sized chains, heavy duty straps, cables and/or binders, securely tie down both the front and rear of the tractor utilizing the proper tie down locations as specified by the tractor manufacturer.



# OPERATION

## 15. TROUBLESHOOTING GUIDE

PROBLEM	POSSIBLE CAUSE	REMEDY
Excessive Vibrations	Check for missing knives on cutter shaft. Check to see if knives are free swinging. Blade broken or bent. Cuttershaft bent. Drivelines not phased correctly. Implements & Tractor yokes must be in line.	Replace missing knives.  Free knives so they swing.  Replace blades. Replace cuttershaft. Replace driveline.
Noise	Damaged Belt Shield (Rubbing on pulleys or belt). Worn Bearing or Gear.	Straighten or replace shields.
Knives Wear Too Fast	Cutting in sandy conditions. Cutting in rocky conditions. Soft "will fit" knives.	Increase cutting height. Increase cutting height. Use genuine Tiger knives.
Hydraulic Cylinder Will Not Operate	Not enough pressure. Valve not connected properly. Quick coupler not completely connected.	Check Pressure. Re-plumb valve. Complete connection.
Oil squirting from Breather Vent Hole	Oil leaking by piston ring.  Piston "O" Ring worn. Cylinder wall scored or pitted. Wrong piston ring on piston.	Do not carry cutter on cylinder. Small leakage amount is normal. Replace piston "O" Ring. Replace cylinder. Use correct piston ring.

# OPERATION

Discharging Bunches	Belt installed improperly. Blades dull. Grass too wet. Grass too long. Travel speed too fast. PTO RPM too low.	Check belt for correct set up. Check blades for sharpness. Wait for grass to dry. Mow at 3-1/2" and re-cut lower. Use a lower tractor gear. Mow at engine RPM to match 540 PTO RPM.
Blades Scalping High Places	Mowing too low. Rough, uneven ground.  Turning Tractor too fast.	Raise height of cut. Use a slower speed. Lower rollers. Slow down when turning.
Uneven Cut	Travel speed too fast. Mower deck not level. Blades dull or unbalanced. Deck underside plugged. Grass too high.	Use a slower speed. Level the mowing deck. Sharpen or balance blades. Clean underside of deck. Mow at 3-1/2" and re-cut lower.
Grass Clippings Windrow or Clump	Grass too wet. Grass too high. Housing plugged.	Wait for grass to dry. Mow at 3-1/2" and re-cut lower. Clean underside of deck.
Grass Not Being Cut Evenly	Belt worn or slipping. Spring broke and belt off idler. Housing plugged. Debris around pulleys.  Grass too high.	Replace or adjust belt. Replace spring or adjust belt. Clean underside of housing. Remove deck belt shield and clean out debris. Mow at 3-1/2" and re-cut lower.

# OPERATION

OPERATION

*Operation Section 3-42*

# MAINTENANCE SECTION

*Maintenance Section 4-1*

# MAINTENANCE

## GENERAL INSTRUCTIONS

Tiger Mowers are designed for high performance and rugged durability, yet with simplified maintenance. The purpose of this section of the manual is to help the operator in the regular servicing of the mower. Regular maintenance at the intervals mentioned will result in the maximum efficiency and long life of the Tiger Mower. When you purchase a Tiger Mower you also acquire another valuable asset, Tiger's parts organization. Our rapid and efficient service has guaranteed the customer satisfaction for many years. Tiger parts keep up with the demands for efficiency, safety and endurance expected of the Tiger Mower.

## MAINTENANCE PRECAUTIONS

- Be sure the end of the grease gun and fittings are clean before using. Debris injected into bearings, etc. with grease will cause immediate damage.
- DO NOT use a power grease gun to lubricate bearings. These require very small and exact amounts of lubrication. Refer to the detailed maintenance section for specific lubrication instructions. DO NOT overgrease bearings.
- Lexan windows should be washed with mild soap or detergent and luke warm water, using a soft clean sponge or soft cloth. DO NOT use abrasive or alkaline cleaners or metal scrapers on lexan windows!
- Be alert to maintenance indicators such as the in-tank filter pressure gauge, hydraulic reservoir sight gauge, etc. Take the required action to correct any problems immediately.
- Release of energy from pressurized systems may cause inadvertent actuation of cylinders, or sudden release of compressed springs. Before disconnecting any hoses relieve pressure by shutting tractor off, setting cutter on ground and actuating lift valve handles.

### **WARNING**

DO NOT use hands to check for suspected leaks in hydraulic hoses! Hydraulic fluid escaping under pressure can have sufficient force to penetrate skin and cause serious injury. If fluid is injected into skin, it must be surgically removed within a few hours or gangrene may result. Use a small piece of wood or cardboard, not hands, to search for pin hose leaks. Be sure all connections are tight and hoses and lines are not damaged before applying pressure.

## BREAK IN PERIOD

In addition to following the break in instructions for your particular tractor, the in-tank hydraulic fluid filter should be replaced after the first 50 hours of service. Thereafter the filter should be replaced every 500 hours, or yearly, whichever comes first.

Re-torque wheel lugs after first five hours of operation and periodically thereafter. See torque specifications listed in the tractor's service manual for your particular model. Wheel lugs must always be re-torqued whenever a wheel is removed and reinstalled.

### **DANGER**

Never work under the Implement, the framework, or any lifted component unless the Implement is securely supported or blocked up to prevent sudden or inadvertent falling which could cause serious injury or even death.



# MAINTENANCE

**⚠ WARNING**

Do not modify or alter this Implement. Do not permit anyone to modify or alter this Implement, any of its components or any Implement function.

**⚠ DANGER**

Always disconnect the wire leads from the mower pump solenoid before performing service on the Tractor or Mower. Use caution when working on the Tractor or Mower. Tractor engine must be stopped before working on Mower or Tractor. The Mower Blades could inadvertently be turned on without warning and cause immediate dismemberment, injury or death.

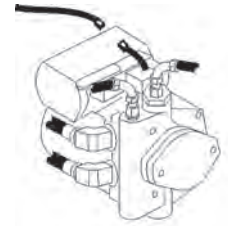

MAINTENANCE

## REGULAR MAINTENANCE

The intervals at which regular servicing should be done are based on hours of operation. Use the tractors hour meter to determine when regular servicing is required.

### Daily or Every 8 Hours

ITEM	SERVICE	COMMENTS
Drive Shaft Yoke, U-Joint & Stub Shaft	Grease	Grease as instructed in detailed maintenance section
Pump Drive Shaft Coupler	Check and Lube	Insure drive shaft end play
Crankshaft Adapter	Check rubber grommets	Replace grommets if damaged or missing
Pivot Points	Lubricate	Inject grease until it appears at ends
Hydraulic Fittings	Check for leaks	Tighten when needed. Do Not use hands to check for leaks, see Maintenance Precautions

# MAINTENANCE

MAINTENANCE

ITEM	SERVICE	COMMENTS
Knives	Check	Inspect for missing or damaged knives, change as needed
Spindle mounting bolts (spindle to deck)	Check	3/4" x 2" or 3/4" x 2-1/2" bolts torque to 331 ft. lbs.
Knife mounting bolts (knife to disk)	Check	Pre-lubricate threads, then torque to 800 ft. lbs. Saber - Torque 1-3/4" knife bolts to 2,000 ft. lbs.
Disk mounting bolts (disk to spindle)	Check	5/8" x 1-3/4" or 5/8" x 2" bolts - torque to 204 dry / 184 oiled ft. lbs.
Belts	Check/Adjust	Check if broken, tighten as required.
Main Frame and Deck	Check	Retorque bolts to torque specifications in this section
Hydraulic Fluid Level	Check	Add if required per fluid recommendations
Rear Flail Drive Bearing Flange and Shaft Coupler	Lubricate	Grease as instructed in detailed maintenance section
Cutter Shaft	Lubricate	Grease as instructed in detailed maintenance section
Ground Roller Bearings	Lubricate	Grease as instructed in detailed maintenance section



# MAINTENANCE

## WEEKLY OR EVERY 50 HOURS

ITEM	SERVICE	COMMENTS
In Tank Hyd. Fluid Filter (10 micron filter)	Change	Change after first 50 hours only, then every 500 hours or yearly
In-Line High Pressure Filter (10 micron filter)	Change	Change after first 50 hours only then every 500 hours or yearly

## MONTHLY OR EVERY 150 HOURS

ITEM	SERVICE	COMMENTS
Hydraulic Fluid Level	Check	Add as needed
Hyd. Tank Breather	Clean/Check/Replace	Clean or replace Element as required
Rear Tire Type 480/80R38 18.4-34 18.4-38		Max P.S.I. 29 26 26

## YEARLY OR EVERY 500 HOURS

ITEM	SERVICE	COMMENTS
Hydraulic Tank Fluid	Change	
In Tank Hyd. Fluid Filter (10 micron filter)	Change	
In-Line High Pressure Filter (10 micron filter)	Change or	Change when indicated by restriction indicator.
Hyd. Tank Breather	Change	
Motor to Cuttershaft Spline Connection	Change	Grease as instructed in the detailed maintenance section

*Maintenance Section 4-5*

MAINTENANCE

# MAINTENANCE

## TROUBLESHOOTING

SYMPTOMS	CAUSE	REMEDY
Vibration	Loose Bolts	Check all bolts and tighten to recommended torque specs.
	Cutter assembly Unbalanced	Check for damaged blades, disc or cuttershaft. Replace if needed. Check for wire, rope, etc. entangled in the cutter assembly
Mower will not lift	Hydraulic Fluid Low Leaks in line	Check and refill hydraulic fluid Tighten or replace fittings and hoses
	Faulty relief valve	Check pressure in line. Line pressure should be at least 2500 PSI
	Kinked or blocked Faulty cylinder	Clean or replace lines Inspect, repair or replace cylinder
Oil temperature rises above 200°F	Low oil level	Bring oil to proper level
	Kinked/ blocked hoses	Inspect, repair or replace
	Worn pump/ motor	Disable and repair
Mower will not start or run	Blown fuse	Check fuse between mower switch and ignition/replace
	Ball valves closed Low oil level Line leak	Make sure valves are open Check hydraulic tank and fill Check all fittings and lines, re-tighten or replace
	Electronic solenoid faulty	Without the tractor running, turn the mower switch to on. A low audible click should be heard if the solenoid is engaging the solenoid spool. If click is not heard, leave switch in ON position and with a screwdriver or other steel object, touch the small nut on the end of the solenoid. If the metallic object is not attracted to the nut, check the fuse and wiring for an open circuit. If the object is attracted but no "click" is heard, replace the solenoid.  Remove the four bolts holding the small block to the main block. Lift and remove small block being careful not to damage Orings/filter. Clean filter and re-install.

# MAINTENANCE

Remove large nut on side of large valve block. Remove spring, and use needle nose vise grip to pull spool from block. Check block and spool for contaminants and scratches. Clean parts or replace if scratched.

Motor runs but will not cut.

Belts

Inspect belts and pulleys. Replace belts and repair as needed.

Tensioner

Adjust tensioner nut until flatwasher is flush with top of guide.

Mower turns slowly or not at all.

Contaminants restricting spool movement in valve body

Remove large nut on side of large valve block. Remove spring, and use needle nose vise grip to pull spool from block. Check block and spool for contaminants and scratches. Clean parts or replace if scratched.

Suction lines obstructed

Check for kinks or obstruction in suction hose.

Low oil level

Check Hydraulic tank level and fill.

Pump will not work

Excessive wear on internal parts.

Disassemble and repair.

Motor will not work

Excessive wear on internal parts

Disassemble and repair.

*NOTE: If flow meter is available, check pressure and flow volume for all suspected hydraulic problems.*

**If the solution to your problem cannot be found in this section, call the Technical Service representative at the number shown on the front cover of this manual.**

# MAINTENANCE

MAINTENANCE

### Torque for Standard Fasteners

Nominal Dia. (in.)	threads per inch	Grade 2			Grade 5			Grade 8			Grade 9		
		Tightening Torque			Tightening Torque			Tightening Torque			Tightening Torque		
		Lubed	Dry Plated	Dry plain	Lubed	Dry Plated	Dry plain	Lubed	Dry Plated	Dry plain	Lubed	Dry Plated	Dry plain
		K = 0.15	K = 0.17	K = 0.20	K = 0.15	K = 0.17	K = 0.20	K = 0.15	K = 0.17	K = 0.20	K = 0.15	K = 0.17	K = 0.20
Unified Coarse Thread Series													
1/4	20	49 in-lbs	59 in-lbs	66 in-lbs	76 in-lbs	86 in-lbs	101 in-lbs	107 in-lbs	122 in-lbs	143 in-lbs	126 in-lbs	143 in-lbs	168 in-lbs
5/16	18	101	122	135	157	178	209	221	251	295	259	294	346
3/8	16	15 ft-lbs	18 ft-lbs	20 ft-lbs	23 ft-lbs	26 ft-lbs	31 ft-lbs	33 ft-lbs	37 ft-lbs	44 ft-lbs	38 ft-lbs	43 ft-lbs	51 ft-lbs
7/16	14	24	29	32	37	42	49	52	59	70	61	70	82
1/2	13	37	44	49	57	64	75	80	90	106	94	106	125
9/16	12	53	63	70	82	92	109	115	130	154	135	153	180
5/8	11	73	87	97	113	128	150	159	180	212	186	211	248
3/4	10	129	155	172	200	227	267	282	320	376	331	375	441
7/8	9	125	150	167	322	365	429	455	515	606	533	604	710
1	8	187	225	250	483	547	644	681	772	909	799	905	1065
1 1/8	7	266	319	354	596	675	794	966	1095	1288	1132	1283	1510
1 1/4	7	375	450	500	840	952	1121	1363	1545	1817	1597	1810	2130
1 1/2	6	652	783	869	1462	1657	1950	2371	2688	3162	2779	3150	3706
Fine Thread Series													
1/4	28	58 in-lbs	68 in-lbs	75 in-lbs	87 in-lbs	99 in-lbs	116 in-lbs	123 in-lbs	139 in-lbs	164 in-lbs	144 in-lbs	163 in-lbs	192 in-lbs
5/16	24	112	135	150	174	197	231	245	279	327	287	325	383
3/8	24	17 ft-lbs	20 ft-lbs	23 ft-lbs	26 ft-lbs	30 ft-lbs	35 ft-lbs	37 ft-lbs	42 ft-lbs	49 ft-lbs	43 ft-lbs	49 ft-lbs	58 ft-lbs
7/16	20	27	32	36	41	47	55	58	66	78	68	78	91
1/2	20	41	49	55	64	72	85	90	102	120	105	120	141
9/16	18	59	71	78	91	103	121	128	146	171	151	171	201
5/8	18	82	99	110	127	144	170	180	204	240	211	239	281
3/4	16	144	173	192	223	253	297	315	357	420	369	418	492
7/8	14	138	165	184	235	403	474	502	568	669	588	666	784
1	14	210	252	280	542	614	722	765	867	1020	896	1016	1195
1 1/8	12	298	357	397	668	757	890	1083	1227	1444	1269	1439	1693
1 1/4	12	415	498	553	930	1055	1241	1509	1710	2012	1768	2004	2358
1 1/2	12	734	880	978	1645	1865	2194	2688	3024	3557	3127	3544	4189

Torque values for 1/4 and 5/16 in series are in inch-pounds. All other torque values are in foot-pounds. K = 0.15 for "lubricated" conditions; D = Nominal Diameter  
Torque values calculated from formula T=KDF, where K = 0.17 for zinc plated and dry conditions; F = Clamp Load  
K = 0.20 for plain and dry conditions

### Torque-Tension Relationship for Metric Fasteners

Nominal Dia. (mm)	Pitch	Class 4.6			Class 8.8			Class 10.9			Class 12.9	
		Tightening Torque			Tightening Torque			Tightening Torque			Tightening Torque	
		Lubed	Dry Plated	Dry plain	Lubed	Dry Plated	Dry plain	Lubed	Dry Plated	Dry plain	Lubed	Dry plain
		K = 0.15	K = 0.17	K = 0.20	K = 0.15	K = 0.17	K = 0.20	K = 0.15	K = 0.17	K = 0.20	K = 0.15	K = 0.20
		(ft-lbs)	(ft-lbs)	(ft-lbs)	(ft-lbs)	(ft-lbs)	(ft-lbs)	(ft-lbs)	(ft-lbs)	(ft-lbs)	(ft-lbs)	(ft-lbs)
3	0.5	0.28	0.32	0.38	0.73	0.82	0.97	1.0	1.2	1.4	1.2	1.8
3.5	0.6	0.44	0.50	0.59	1.1	1.3	1.5	1.6	1.9	2.2	1.9	2.5
4	0.7	0.66	0.74	0.87	1.7	1.9	2.3	2.4	2.7	3.2	2.8	3.8
5	0.8	1.3	1.5	1.8	3.4	3.9	4.5	4.9	5.5	6.5	5.7	7.6
6	1	2.3	2.6	3.0	5.8	6.6	7.7	8.3	9.4	11	9.7	13
6	1.25	2.1	2.3	2.7	5.3	6.0	7.0	7.6	8.6	10	8.8	12
7	1	3.8	4.3	5.0	9.7	11	13	14	16	19	16	22
8	1	5.9	6.6	7.8	15	17	20	22	24	29	25	34
8	1.25	5.5	6.2	7.3	14	16	19	20	23	27	24	31
10	1.25	11	13	15	29	33	39	42	48	56	49	66
10	1.5	11	12	14	28	32	37	40	45	53	47	62
12	1.25	21	23	28	53	60	71	76	86	101	89	119
12	1.5	20	22	26	51	58	68	73	82	97	85	113
12	1.75	19	21	25	49	55	65	70	79	93	81	108
14	1.25	26	29	34	66	75	89	95	108	127	111	148
14	1.5	28	32	37	72	82	96	103	117	138	121	161
14	2	30	34	40	78	88	104	111	126	148	130	173
16	1.5	50	57	67	129	146	171	184	208	245	215	287
16	2	47	53	62	121	137	161	173	196	230	202	269
18	1.5	73	82	97	187	212	249	268	303	357	313	417
18	2.5	65	73	86	167	189	222	239	270	318	279	372
20	1.5	101	115	135	270	306	360	374	424	498	437	583
20	2.5	91	104	122	236	267	314	337	382	449	394	525

Clamp load calculated as 75% of the proof load for specified bolts. K = 0.15 for "lubricated" conditions; D = Nominal Diameter  
All torque values are listed in foot-pounds; K = 0.17 for zinc plated, dry conditions; F = Clamp Load  
Torque values calculated from formula T=KDF, where K = 0.20 for plain and dry conditions

# MAINTENANCE

## LUBRICATION RECOMMENDATIONS

Description	Application	General Specification	Recommended Mobil Lubricant
Tractor Hydraulics	Reservoir	JD-20C MF M1135, M1141 FNHM2C134D	Mobilfluid 424
Mower Hydraulics Cold Temperatures 0°F Start-Up Normal Temperatures 10°F Start-Up	Reservoir	ISO 46 Anti-Wear-Low Temp JD20C MF M1135, M1141 FNH M2C134D (FNH201)	Mobil DTE 15M Mobilfluid 424
Normal Temperatures 15°F Start-Up High Operating Temp. Above 90°F		ISO 46 Anti-Wear ISO 100 Anti-Wear	Mobil DTE 25 Mobil DTE 18M
Flail Rear Gearbox	Reservoir	PAO Synthetic Extreme Pressure Gear Lube	Mobil SHC 75W-90 Mobil 1 Synthetic Gear
Cutter Shaft & Ground Roller Shaft (Flail)	Grease Gun	Lithium-Complex Extreme Pressure NLGI-2 - ISO 320	Mobilgrease CM-S
Drive Shaft Coupler (Flail and Rotary)	Grease Gun	Lithium-Complex Extreme Pressure NLGI2 - ISO 320	Mobilgrease CM-S
Motor to Cuttershaft Spline Connection	Fill Female Spline in Cuttershaft		Accrolube with PTFE

MAINTENANCE

# MAINTENANCE

## POLYCARBONATE CARE & MAINTENANCE

The propriety UV and Abrasion Resistant surface coating on SHIELDS® SUPERCOATED™ polycarbonate significantly improves performance. Periodic cleaning using proper procedures and compatible cleaners are recommended to prolong service life. Tiger Corp. polycarbonate is SUPERCOATED™ on both sides.

### CLEANING THE SUPERCOAT™ HARD-COAT

1. Wash with a mild solution of soap or detergent and lukewarm water.
2. Using a soft cloth or sponge, gently wash the sheet to loosen dirt and grime and rinse well with clean water.
3. To prevent water spotting, thoroughly dry with chamois or cellulose sponge.
4. Avoid the use of abrasive cleaners, squeegees and/or other cleaning implements that may mar or gouge the coating.

### CLEANING AGENTS WHICH HAVE BEEN FOUND TO BE COMPATIBLE UNDER LABORATORY CONDITIONS:

• Aqueous Solutions of Soaps and Detergents

Windex	Top Job	Joy	Mr. Clean
Fantastik	Formula 409	Sumalight D12	Brucodecid

• Organic Solvents

Butyl Cellosolve	Kerosene	Hexel, F.O. 554	Naphtha (VM&P grade)
Neleco-Placer	Turco 5042		

## GRAFFITI REMOVAL

Butyl cellosolve (for removal of paints, marking pen inks, lipstick, etc.). The use of masking tape, adhesive tape or link removal tools works well for lifting off old weathered paints.

To remove labels, stickers, etc., the use of kerosene or VM&P naphtha are generally effective. When the solvent will not penetrate sticker material, apply heat (hair dryer) to soften the adhesive and promote removal.

If a material is found to be incompatible in a short-term test, it will usually be found to be incompatible in the field. The converse, however, is not always true. Favorable performance is no guarantee that actual end-use conditions have been duplicated. Therefore, these results should be used as a guide-only, and it is recommended that the user test the products under actual end-use conditions.

# MAINTENANCE

## RECOMMENDED FILLING INSTRUCTIONS FOR HYDRAULIC RESERVOIRS

When filling or checking the oil level, the unit should be parked on a level surface, - shut "OFF", and allow sufficient time to cool to ambient temperature. Use caution when removing the pressurized breather. Do not place face over opening when removing breather.

The reservoir has two sight glasses: The reservoir should be filled to the top of the lower sight glass on the side of the tank. Do not over-fill. The reservoir has been over-filled when oil is visible in the upper sight glass. If tank has too much oil, the excess may be expelled through the pressurized breather.

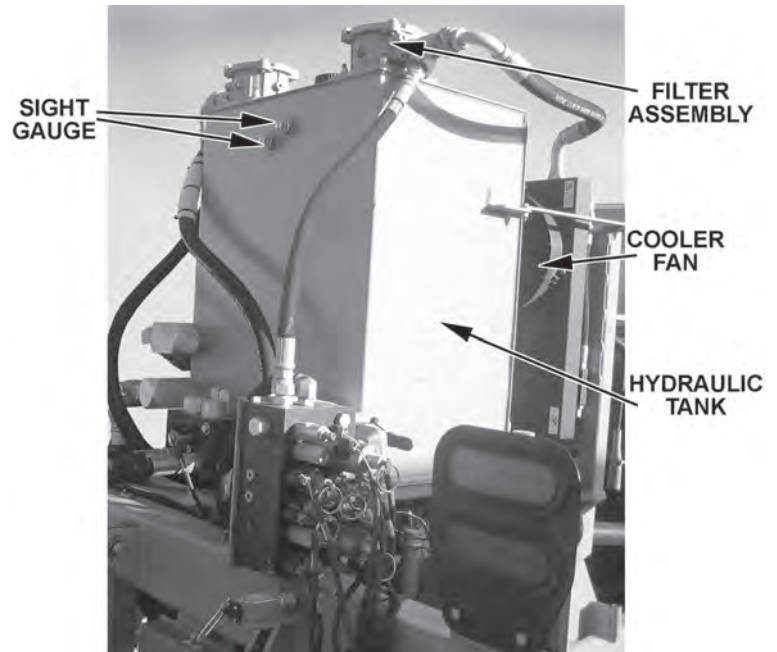

## REPLACING IN-TANK HYDRAULIC FILTER

Loosen the four bolts on the top cover of the filter housing. Turn cover counter-clockwise until cover is free. Remove and replace filter. Replace top cover and cover bolts in opposite order as removed.



# MAINTENANCE

MAINTENANCE

## GREASING INNER AND OUTER DRAFT BEAM PIVOT POINTS

Locate the grease zerks on the inner and outer draft beam pivot bosses. Inject Lithium-Complex Extreme Pressure grease conforming to NLG12-ISO 320 specifications into each zerk until grease protrudes from joints. Grease all pivot points daily or every 8 hours of service.

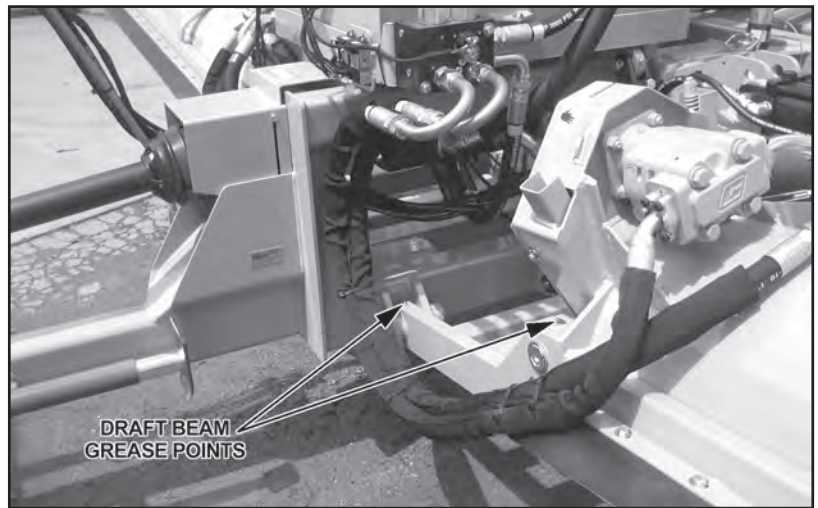

With the cutter head lowered, locate the grease zerks on the linkage and pivot bosses. Inject Lithium-Complex Extreme Pressure grease conforming to NLG12-ISO 320 specifications until it protrudes from the ends. With the cutter head in this position, it is also possible to grease the draft beam cylinder anchors and pins. Now, raise the cutter head to expose the remaining zerks on the deck tilt linkages and on the other end of the

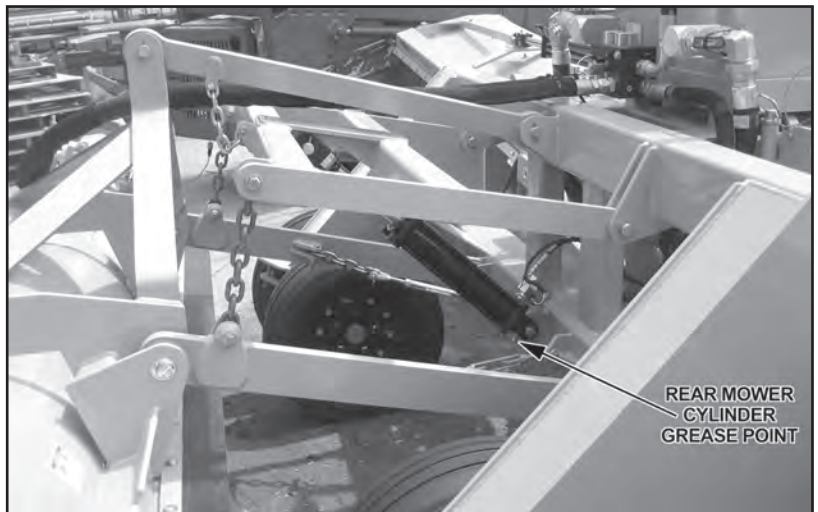



# MAINTENANCE

## GREASING PUMP DRIVE SHAFT COUPLER

With engine stopped, ensure drive shaft alignment by grasping coupler and sliding back and forth. Coupler should slide freely with approximately 1/8" of end play. If coupler does not slide freely, inspect for loose pump mount bolts, or damaged or loose crank shaft adapter. Inject-Lithium Complex Extreme Pressure grease conforming to NLGI2-ISO 320 specifications into coupler until grease begins to protrude from ends. Grease daily or every 8 hours. Do not over grease.

Grease support bearing, inject lithium complex extreme pressure grease conforming to NLGI-2 ISO 320 specifications. Normal conditions require 1-2 pumps. This is to be done with standard grease gun daily or at 8 hour intervals. *Caution: over greasing may cause premature seal failure.*

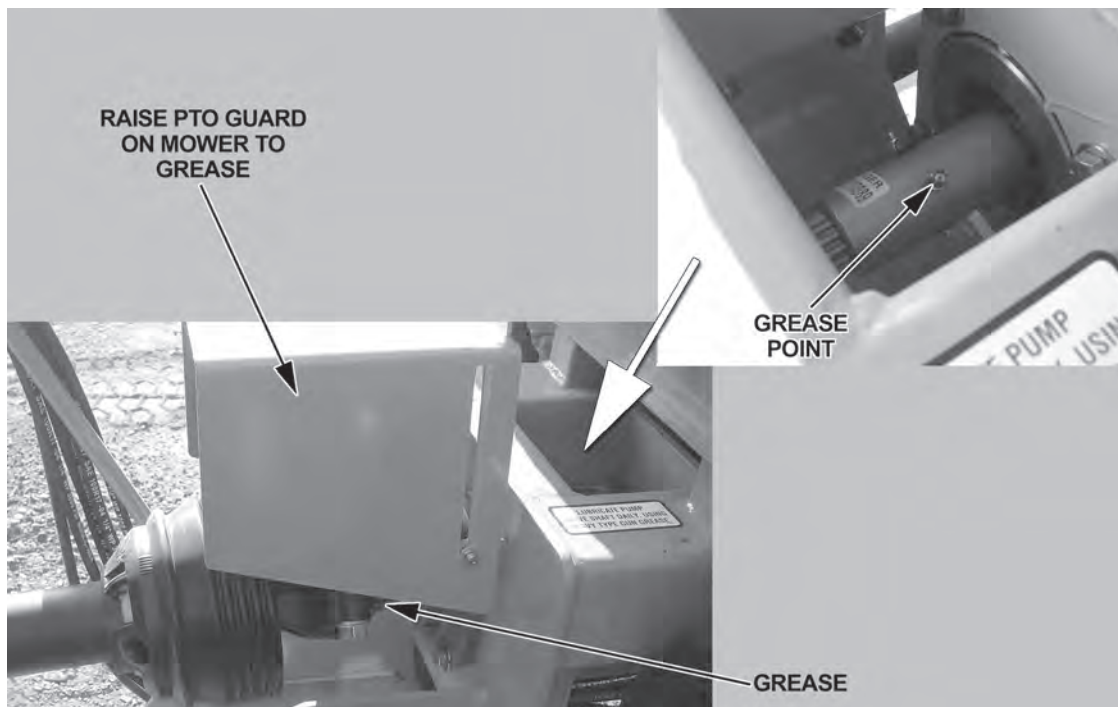

# MAINTENANCE

MAINTENANCE

## ADJUSTING THE CUTTING HEIGHT

Loosen the four ground roller bracket locknuts. Loosen the adjustment rod locknut and turn the adjustment rod to adjust the cutting height. The cutting height is indicated by the end of the adjustment rod on the cutting height decal. When cutting height has been achieved, tighten the ground roller bracket locknuts and the adjustment rod locknut securely. Be sure both sides of the flail are adjusted the same.

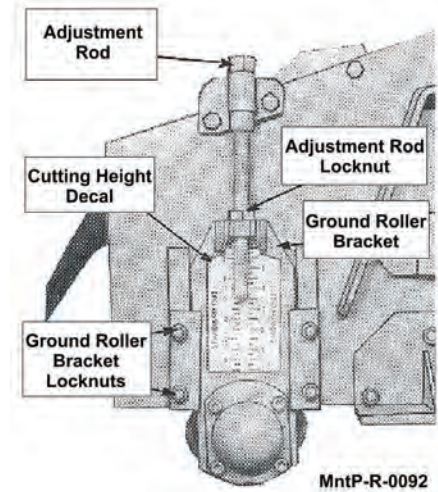

## ADJUSTING STANDARD DUTY CUT HEIGHT

To adjust the cutting height of the standard duty flail head the two nuts on the roller shaft brackets must be taken off and moved to the desired location/height. Be sure that both sides of the shaft are adjusted to corresponding holes so the shaft remains level.

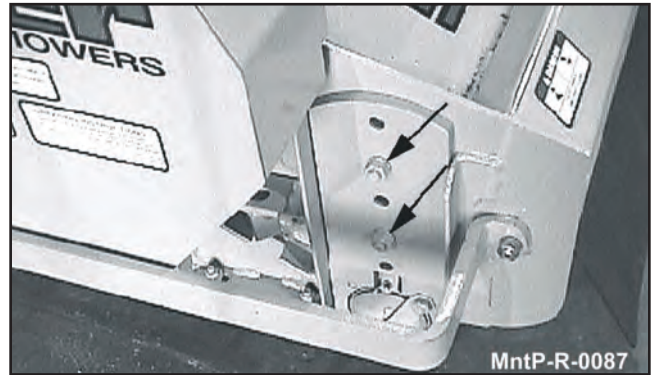

## GREASING PTO SHAFTS

After bringing the tractor to a complete stop, shut off the engine and remove the PTO shaft from the tractor. Slide the shaft apart to expose the grease zerk. Grease the shaft with 5 pumps of grease and the U-joints until grease protrudes from caps per the scheduled interval shown in the chart found earlier in this Maintenance Section.

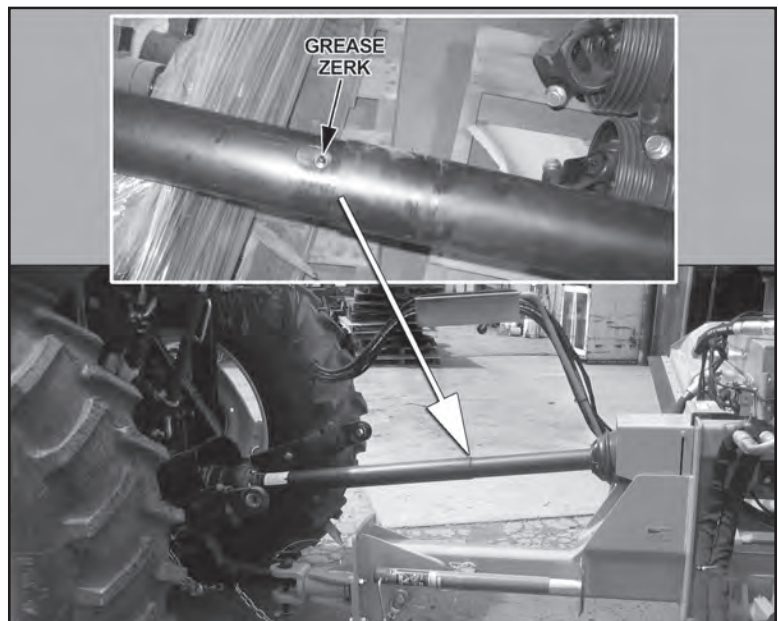

# MAINTENANCE

## BALL VALVES

The ball valve at the hydraulic reservoir may need to be closed during certain maintenance or repair procedures. **THE BALL VALVE MUST BE OPEN (handle parallel with valve) WHEN TRACTOR IS RE-STARTED OR PUMP IS COUPLED TO MOTOR OR P.T.O.!** Failure to do so will result in component failure!

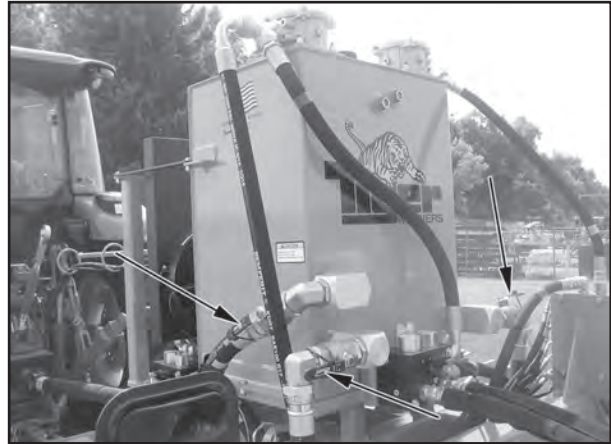

## GREASING CUTTER SHAFT-FLAIL MOWERS

Locate grease zerks on each end of cutter shaft(s). These are located on the bearing cover. Normal conditions require one or two pumps in each bearing, using Lithium-Complex Extreme Pressure grease conforming to NLGI2-ISO 320 specifications. This is to be done with a standard grease gun daily or at 8 hour intervals. **CAUTION:** *Over greasing may cause premature seal failure.*

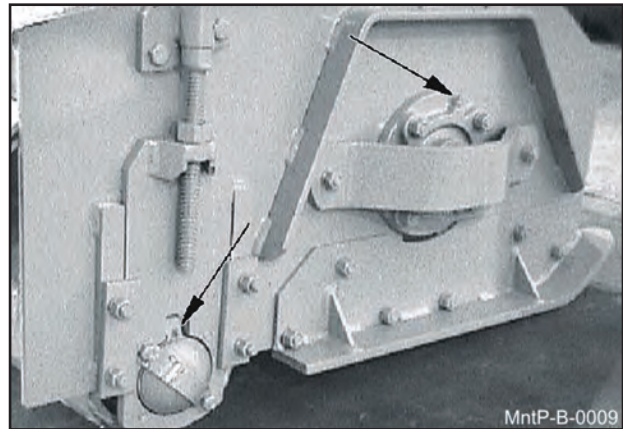

## GREASING GROUND ROLLER SHAFT-FLAIL

Locate grease zerks on each end of roller tube at lower rear of head. Normal conditions require one or two pumps in each bearing, using Lithium-Complex Extreme Pressure grease conforming to NLGI2-ISO 320 specifications. This is to be done with a standard grease gun daily or at 8 hours intervals. **CAUTION:** *Over greasing may cause premature seal failure.*

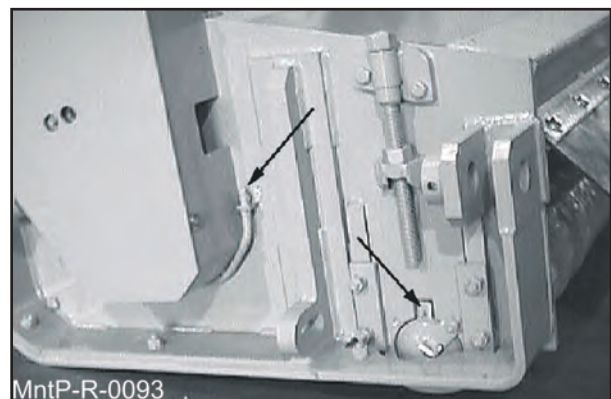

# MAINTENANCE

MAINTENANCE

## GREASING THE IDLER TENSION ARMS

Locate the access holes and grease zerks in the belt shields of the side and rear flails. Normal conditions require one pump daily or every 8 hours of service with multi-purpose grease.

## IDLER TENSION

Locate the idler tensioning rod for each flail. Loosen the locking nut. Turn the adjusting nut until the washer between the spring and nuts are flush with the spring housing or guide. Tighten locking nut securely. For standard cut on side flail adjust until the spring washer is flush with the top of the spring housing. Use the same method to adjust hydraulically driven rear flails.

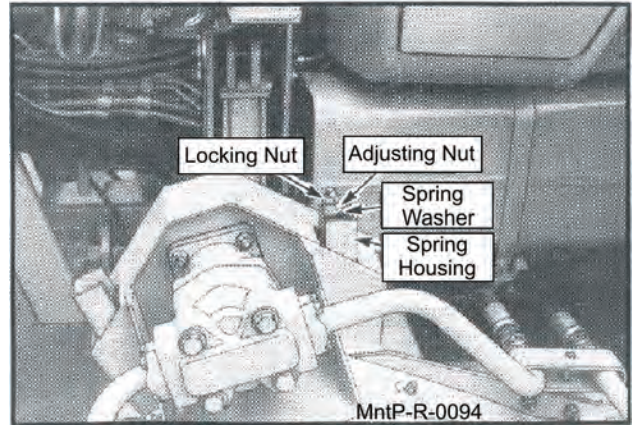

For standard cut on the mechanically driven rear flail mower, adjust so that the spring washer is flush with the spring guide.

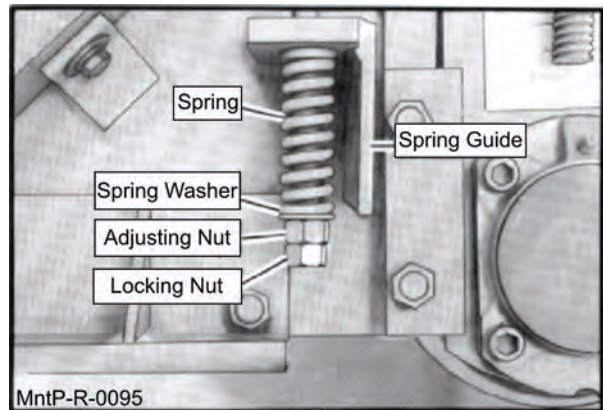

## WHEEL

Lug nuts are to be oriented with the flat side facing the wheel. Torque nuts to 80-90 ft-lbs. Check monthly or every 150 hours.

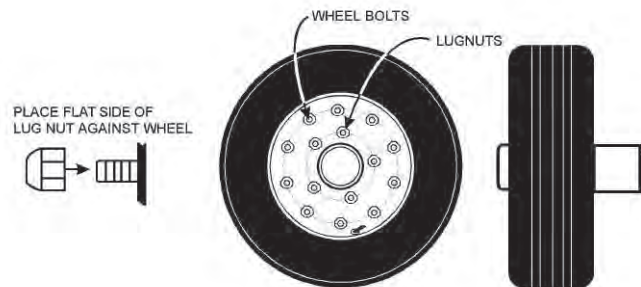

# MAINTENANCE

## TENSIONER MEASUREMENT PROCEDURE

1. Measure the Belt Span (SEE SKETCH).
2. Position the bottom of the Large "O" Ring on the Span Scale at the measured Belt Span.
3. Set the Small "O" Ring on the Deflection Force Scale to Zero.
4. Place the tension gauge squarely on the belt at the center of the belt span. Apply a force on the plunger perpendicular to the belt span until the bottom of the Large "O" Ring is even with the bottom of a straight edge laid across the sheaves.
5. Remove the tension gauge and read the force applied from the bottom of the Small "O" Ring on the Deflection Force Scale.
6. Compare the force denoted by the Small "O" Ring with the values shown. The force should be between the values given for either a New Belt or Used Belt.
7. Make sure to use the force values in pounds if the span is measured in inches. Use kilograms of force if the span is measured in centimeters.

NOTE: The ratio of the deflection to belt span is 1/64 in either units of measurements.

### Deflection Force Values - Standard Duty

**New Belt: 20 to 25 pounds**

**Used Belt: 12 to 20 pounds**

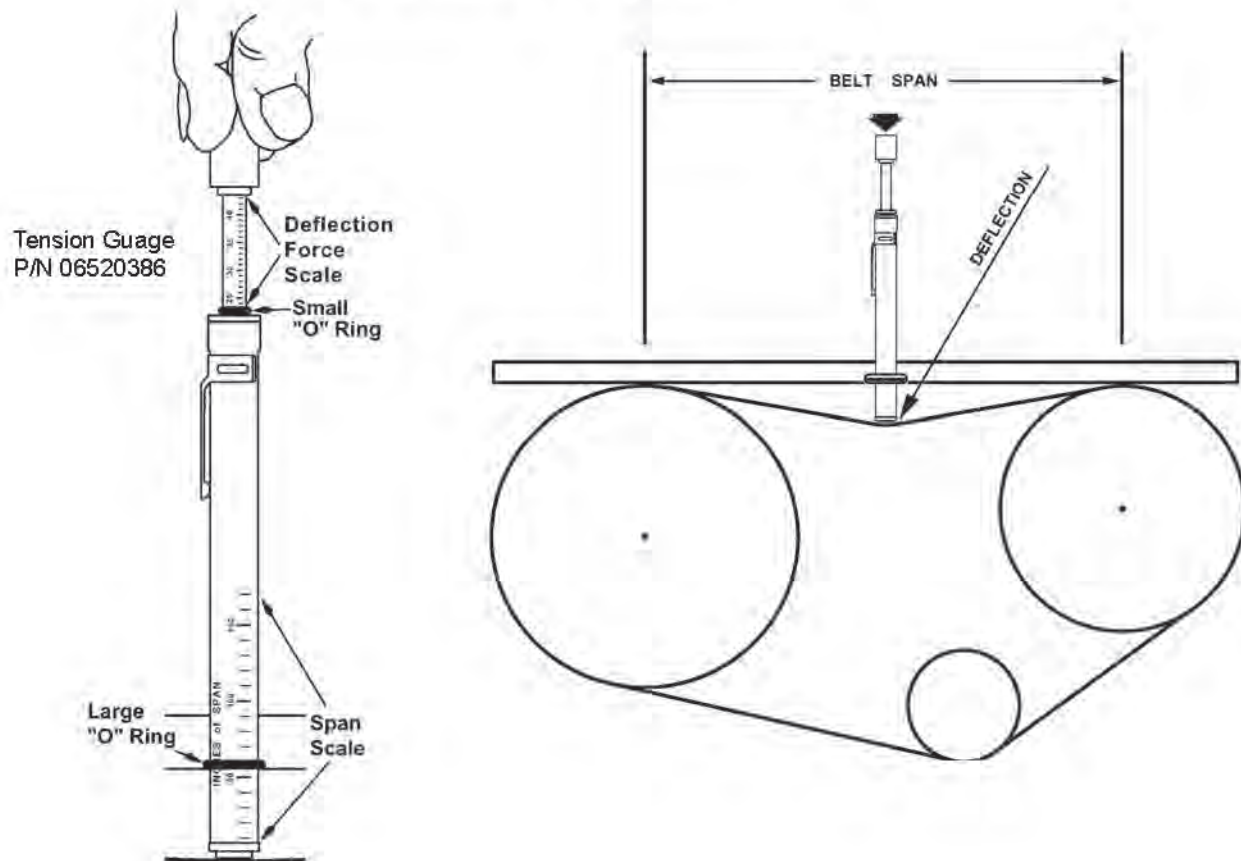

# MAINTENANCE

## REVERSING MOWER ROTATION OF SIDE AND REAR FLAIL MOWERS

To reverse the rotation of the side and hydraulically driven rear flail, a different idler arm is needed only for side flail. Part No. TF4346 is used in standard rotation. Part No. TF4345 is used in reverse rotation.

Before attempting this procedure, be sure all dirt is cleaned away from the motor and around all hose connections. This will prevent the oil from becoming contaminated.

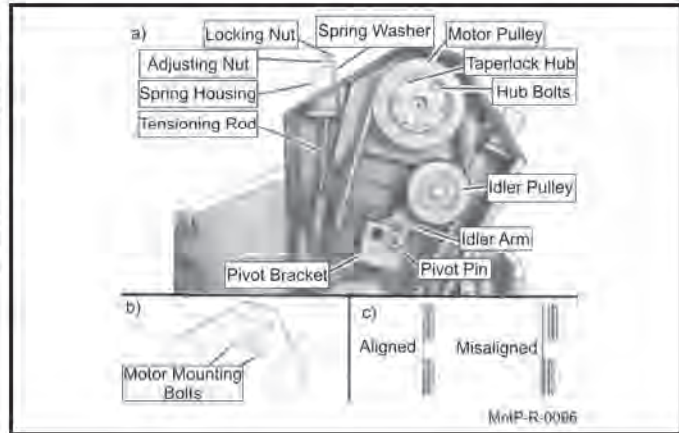

1. Start by removing the belt shield from the flail mower.
2. Remove the locking and adjusting nut, spring washer and spring from the idler tensioning rod.
3. Disconnect the tensioning rod from the idler arm.
4. Remove the idler arm with the pulley attached.
5. Remove the idler pulley from the idler arm and reinstall in the short end of the new idler arm.

Reinstall the idler arm and pivot pin. The pivot pin is installed into the hole in the pivot bracket closest to the idler pulley. When assembling for **standard** cut rotation, the idler arm is installed with the idler pulley toward the front of the mower with the pivot pin in the front hole. When assembling for **reverse** rotation, with smooth cut knives, the idler arm is installed with the pulley toward the rear of the mower with the pivot pin in the rear hole.

Now disconnect the hoses and fittings from the motor and remove the taper-lock hub and pulley from the motor by removing the three hub bolts from the existing positions and inserting simultaneously into the threaded holes. Remove the four bolts holding the motor. Rotate the motor 180° so the hump is opposite the prior position. Reinstall the motor bolts and torque to 75 ft. lbs. Reconnect the hoses and fittings to the motor in the same configuration as before, i.e. the hose that was connected to the front port on the motor should now be connected to the port that is now facing the front.

Reinstall the taper-lock hub and pulley on the motor by installing the hub bolts in the original holes and tightening until the hub just contacts the pulley. Then, position the pulley on the motor shaft approximately 3/16" beyond the idler pulley and tighten and torque the hub bolts to 18 ft./lbs. Be sure the pulleys are vertically aligned when tight (see **Figure MntP-R-0096**), loosen and readjust if needed.

Reinstall the belts and idler tensioning rod. Tighten and lock the tensioning rod as shown previously in the maintenance section. Reinstall the belt shield.

With the motor rotation changed, now all of the knives on the cutter shaft must be changed as required. The cutter shaft rotates in the same direction as the tractor tires when going forward for standard cut knives. The shaft rotates opposite to standard rotation for smooth cut knives. Smooth cut knives should be installed so the cutting edge is forward.

# MAINTENANCE

When operating in standard rotation, the front shield must be removed and the baffle installed. When operating in reverse rotation, remove the baffle and install the front shield. Finally, reposition the wear pads on the hoses and replace the zip ties as needed to prevent the hydraulic hoses from rubbing or chafing.

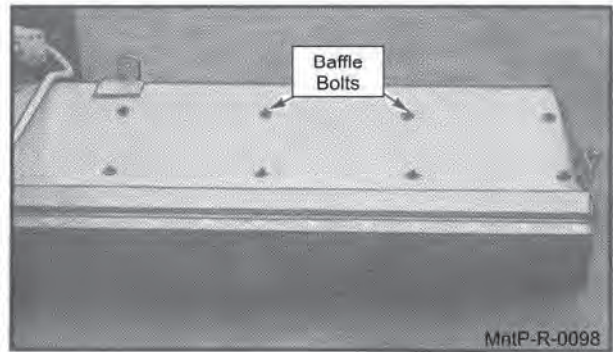
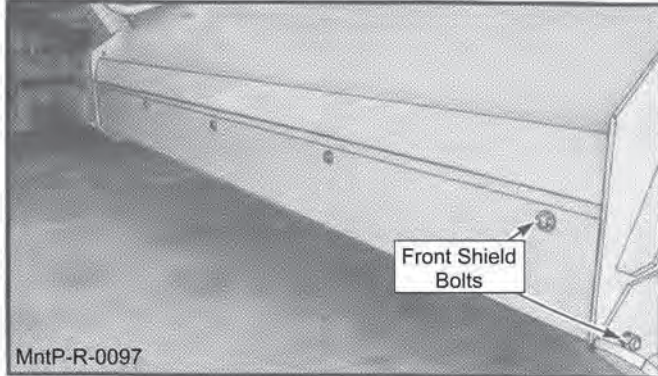

# MAINTENANCE

## Flail Blades Inspection



Inspect the Blades daily for abnormal wear. REPLACE ALL BLADES on the carrier IMMEDIATELY if any blades have:

- Become bent or deformed from its original shape, or
- Wear inside the blade bolt hole, or
- Any cracks are visible, or
- Deep gouges in the blade's surface are present, or
- Gouges or chipped areas in the cutting edge are larger than 1/4"(8mm), or
- The material on the leading edge has been worn away by more than 1/4"(8mm)

**DO NOT** straighten, sharpen, weld or hard-face blades

Failure to replace worn or damaged blades may lead to catastrophic failure of the blades and ejection of the broken part with tremendous force which may cause serious bodily injury or death.

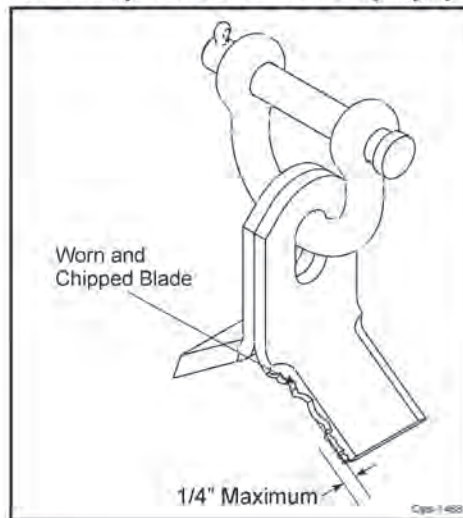

Always replace blades in sets

- Blades that are damaged may indicate severe service or abuse. If one blade is worn or damaged other blades on the same shaft will have been subjected to the same severe service or abuse.
- The Flail rotor turns at speeds exceeding 2000 RPM and is dynamically balanced at the factory. Differences in blade weight between used blades with loss of material from gouges or wear as compared to new blades can cause severe vibration and damage to the Flail rotor. Always replace blades as complete sets.



Use only genuine Alamo Industrial replacement blades and fasteners. Other blades and fasteners may not meet the Alamo Industrial requirements and could fail during operation resulting in part being thrown out from under the mower.



Never attempt to sharpen blades. OPS-U-0044



# MAINTENANCE

## Blade Pins and D-Ring Inspection

Blade Pins and D-Rings daily for wear or damage as follows:



Inspect the Blade pins and D-Rings daily for abnormal wear. Make sure the cotter pins are in place and properly spread. REPLACE BLADE Pins and D-Rings IMMEDIATELY if they have:

- Visible cracks or
- If a Pin or D-Ring has visible worn areas, or
- If a Pin or D-Ring has gouges or chipped areas

Failure to replace abnormally worn pins or D-Rings may lead to catastrophic failure and ejection of the broken part which may cause serious bodily injury or death.

Always replace the pins and D-Rings whenever excessive wear is noticed.

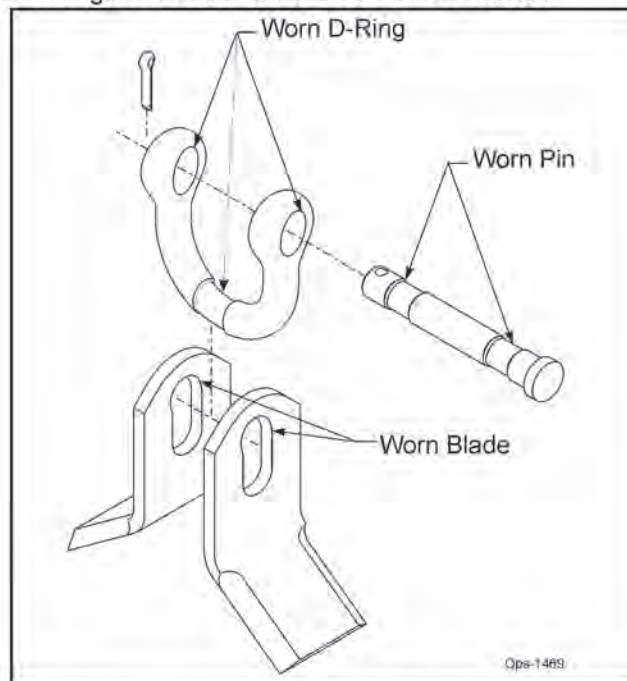

### **Important**

If the cotter pins are broken by contact with other flail blades, remove the pin and reverse the direction the pin is inserted through the D-Ring so that the cotter pin is on the opposite side of the D-Ring. This will prevent the next set of blades from swinging back and hitting the cotter pin. OPS-U-0045

# MAINTENANCE

## STANDARD OR HEAVY DUTY SIDE OR REAR FLAIL KNIFE REPLACEMENT

1. If knives are damaged or badly worn, they will need to be replaced as a set. Replacing a single knife can cause severe vibration and possible damage to the mower.
2. Assemble knives, clevis, bolts and nuts as shown in parts manual.
3. Install locking hex nut so that the flat face of nut is towards the knife.
4. Apply loctite "271" or equivalent to threads.
5. Torque nut to 52 FT. LBS. Knife must swing freely.



**WARNING**

DO NOT re-use the locking hex nuts for mounting the knives. If hex nut become loose, or require removal for knife replacement or any other reason, they must be discarded and replaced with new nuts.



**WARNING**

Knives should not be welded on for any reason.

# MAINTENANCE

## CUTTERSHAFT BEARING REPLACEMENT

1. Remove existing cuttershaft, bearings and string guards.
2. Make sure that the end knives on each end of the cuttershaft are oriented as shown.
3. Apply anti-seize on cuttershaft as shown on next page.
4. Install non-drive side bearing first.
5. Install the top of the string guard on the non-drive side first. Use loctite-271 or equivalent and torque (95 ft-lb or 104ft-lb if you use an extension).
6. Install the bearing and top string guard on the drive side.
7. Center the cuttershaft between the string guards. Use loctite-271 or equivalent and torque (95ft-lb or 104ft-lb if you use an extension) the top string guard on the drive side.
8. Install, use loctite-271 or equivalent, and torque (95ft-lb or 104ft-lb if you use an extension) the bottom string guard on both sides.
9. Make sure the cuttershaft is centered. On the non-drive side, tighten one set-screw in the bearing onto the cuttershaft.
10. Remove the other set-screw and drill a 5/16" hole into the cuttershaft 3/16" deep through the hole in the bearing. BE CAREFUL NOT TO DAMAGE THE THREADS IN THE BEARING HOLE.
11. Replace the set-screw in the bearing, use loctite-271 or equivalent, and tighten onto the cuttershaft through the new hole.
12. Remove the other set- screw and repeat the drilling procedure (Step 10). Replace the set screw as stated in Step 11.
13. Repeat steps 9 through 12 on the drive side.
14. Grease both bearings properly.

See illustration on next page

# MAINTENANCE

MAINTENANCE

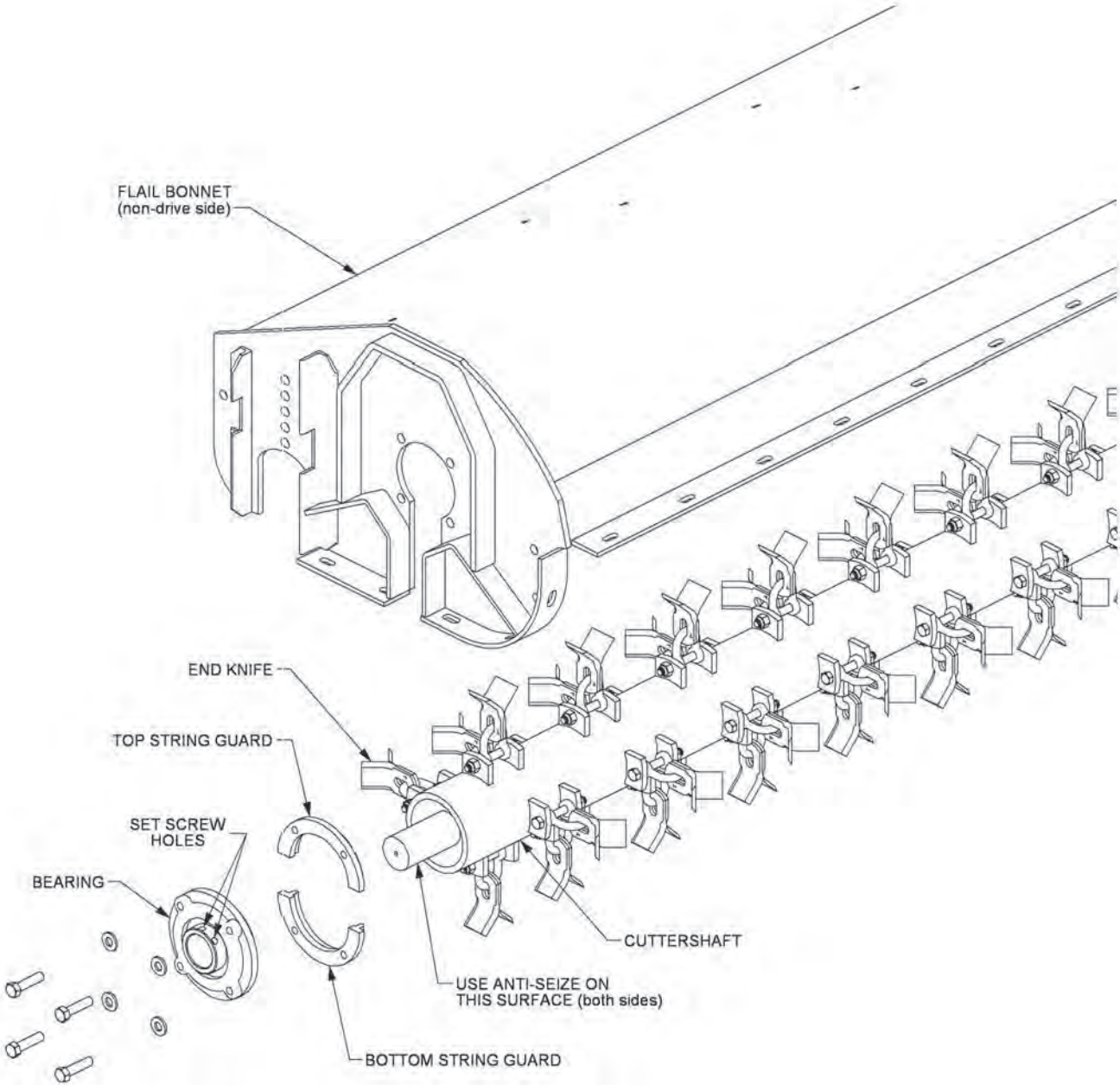

**TIGER TRIPLE THREAT PULL BEHIND MOWER**

**PARTS SECTION**

# PART NAME INDEX

PARTS ORDERING GUIDE.....	3
TPF MAINFRAME MOUNT.....	4
TPF REAR MOWER MOUNT.....	6
TPF WHEEL ASSEMBLY.....	8
NOTES.....	9
TPF HYDRAULICS.....	10
TPF HYDRAULICS - MOWERS.....	12
TPF HYDRAULIC DIAGRAM.....	13
DRAFT BEAMS.....	14
TPF MANIFOLD.....	16
NOTES 2.....	17
TPF WIRE HARNESS - TRACTOR.....	18
TPF WIRE HARNESS - TRAILER.....	19
75IN SIDE MOWER ASSEMBLY.....	20
90IN REAR MOWER - STANDARD ROTATION.....	22
SIDE AND REAR MOWER DRIVE ASSEMBLY.....	24
SIDE MOWER MOTOR BREAKDOWN.....	26
06510083 BRAKE VALVE ASSEMBLY.....	28
PTO BREAKDOWN 00791764.....	29
3IN X 10IN HYDRAULIC CYLINDER BREAKDOWN.....	30
3IN X 18IN HYDRAULIC CYLINDER BREAKDOWN.....	32
3IN X 8IN HYDRAULIC CYLINDER BREAKDOWN.....	34
NOTES 3.....	36

## PARTS ORDERING GUIDE

The following instructions are offered to help eliminate needless delay and error in processing purchase orders for the equipment in this manual.

1. The Parts Section is prepared in logical sequence and grouping of parts that belong to the basic machine featured in this manual. Part Numbers and Descriptions are given to help locate the parts and quantities required.
2. The Purchase Order must indicate the **Name and Address** of the person or organization ordering the parts, **who should be charged**, and if possible, the **serial number of the machine** for which the parts are being ordered.
3. The purchase order must clearly list the **quantity of each part**, the complete and correct **part number**, and the basic **name of the part**.
4. The manufacturer reserves the right to substitute parts where applicable.
5. Some parts may be unlisted items which are special production items not normally stocked and are subject to special handling. Request a quotation for such parts before sending a purchase order.
6. The manufacturer reserves the right to change prices without prior notice.

NOTE: When ordering replacement decals, refer to the part numbers and descriptions listed in the safety section in the front of this manual.

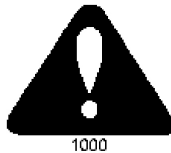

For maximum safety and to guarantee optimum product reliability, always use genuine **Tiger** replacement parts. The use of inferior replacement parts may cause premature or catastrophic failure which could result in serious injury or death.

Direct any questions regarding parts to:

**Tiger Corporation**  
3301 N. Louise Ave.  
Sioux Falls, SD 57107  
1-800-843-6849  
1-605-336-7900

## TPF MAINFRAME MOUNT

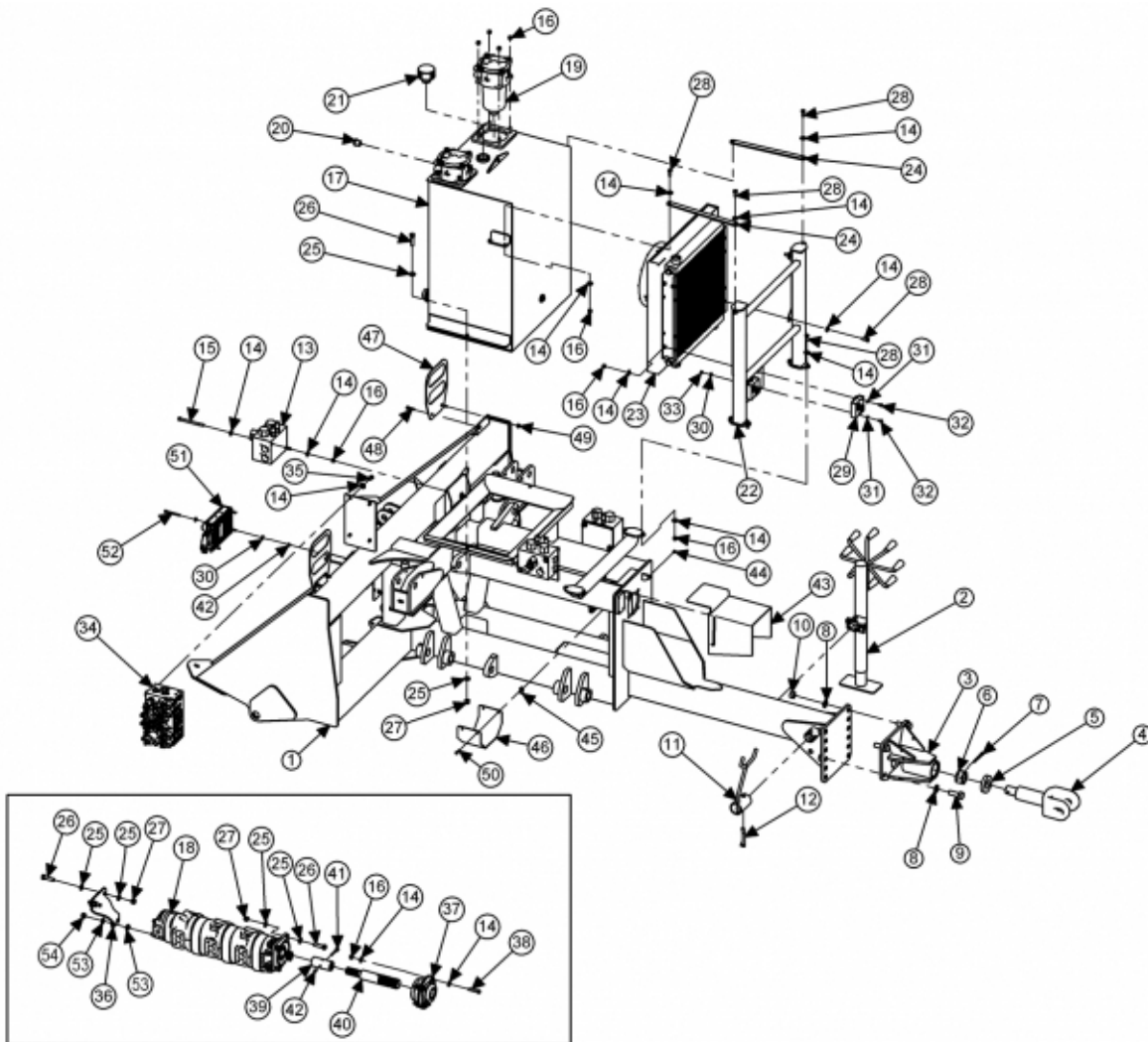

ITEM	PART NO.	QTY.	DESCRIPTION
1	06300333	1	MAINFRAME, TPF, 2, ED
2	23964	1	JACK, REAR, VERSATILE, T3F, SIDE
3	06350023	1	MOUNT, HITCH, TPF
4	791214	1	CASTING, ROLL CLEVIS
5	779221	1	PLATE, SWIVEL NUT WASHER
6	5D2460	1	NUT, HEX SLOTTED, 1-1/2-6 PLATED
7	165024	1	COTTER PIN, 5/16"X3"
8	33880	8	FLATWASHER, 3/4" GR8, SAE
9	06530237	4	CAPSCREW, 3/4" X 2-1/4" NC GR8
10	06531008	4	HEX NUT, 3/4" NC GR8
11	06370232	1	SUPPORT, PTO, TPF
12	06520048	1	PIN, 5 X 2.5, BENT, W/R-CLIP
13	06510083	3	BRAKE VALVE, SOL 3000PSI
14	22016	48	FLATWASHER, 3/8" GR8



**TPF MAINFRAME MOUNT**

**Continued...**

<b>ITEM</b>	<b>PART NO.</b>	<b>QTY.</b>	<b>DESCRIPTION</b>
15	21644	6	CAPSCREW, 3/8"X5" NC
16	21627	30	NYOCK NUT, 3/8" NC
17	06380091	1	TANK, RES, TPF 2
18	06504146	1	PUMP, TPF, QUAD
19	06505044	1	FILTER, ASSY, IN-TANK CPLT
20	6T1209	2	SIGHT GLASS, TANK
21	06505077	1	CAP, BREATHER, 5/8MB
22	06380092	1	MOUNT, COOLER, TPF 2
23	06510301	1	COOLER, TPF
24	06402487	2	BRACE, COOLER
25	06533004	20	FLATWASHER, 1/2" SAE, GR8
26	21733	8	CAPSCREW, 1/2" X 2", NC
27	21727	10	NYLOCK NUT, 1/2" NC
28	21630	12	CAPSCREW, 3/8" X 1" NC
29	06510319	2	H BRIDGE, FAN CONTROL, TPF 2
30	22014	12	FLATWASHER, 1/4" GR8
31	21986	4	LOCKWASHER 1/4"
32	21528	4	CAPSCREW, 1/4" X 1/2" NC
33	21525	4	HEX NUT, 1/4" NC
34	06510323	1	MANIFOLD, CONTROL, CNBS, TPF 2
35	21630	4	CAPSCREW, 3/8" X 1" NC
36	06411728	1	MOUNT, LOWER, PUMP
37	06520556	1	BEARING, FLANGE, 4-HOLE 1.75
38	21634	4	CAPSCREW, 3/8" X 2" NC
39	06420185	1	COUPLER, TPF
40	06420186	1	SHAFT, 1.75 X 1.25 TPF
41	21535	1	CAPSCREW, 1/4" X 2-1/4" NC
42	21527	5	HEX NUT, NYLOCK 1/4" NC
43	06380088	1	GUARD, PTO, TPF
44	94035A1 7	2	CAPSCREW, SKTHD, SHLDR, 10/32X25
45	35176	4	U-NUT, 1/4, 3/4 TO CENTER
46	06411720	1	GUARD, COUPLER, TPF
47	06402119	2	MOUNT, ASAE279.17
48	21581	4	CAPSCREW, 5/16" X 1-1/2" NC
49	21577	4	HEX NUT, NYLOCK, 5/16" NC
50	21530	4	CAPSCREW, 1/4" X 1" NC, GR8
51	06510322	1	CONTROLLER, TPF 2
52	21538	4	CAPSCREW, 1/4" X 3" NC
53	22017	4	FLATWASHER, 7/16"
54	21650	2	HEX NUT, 7/16"

# TPF REAR MOWER MOUNT

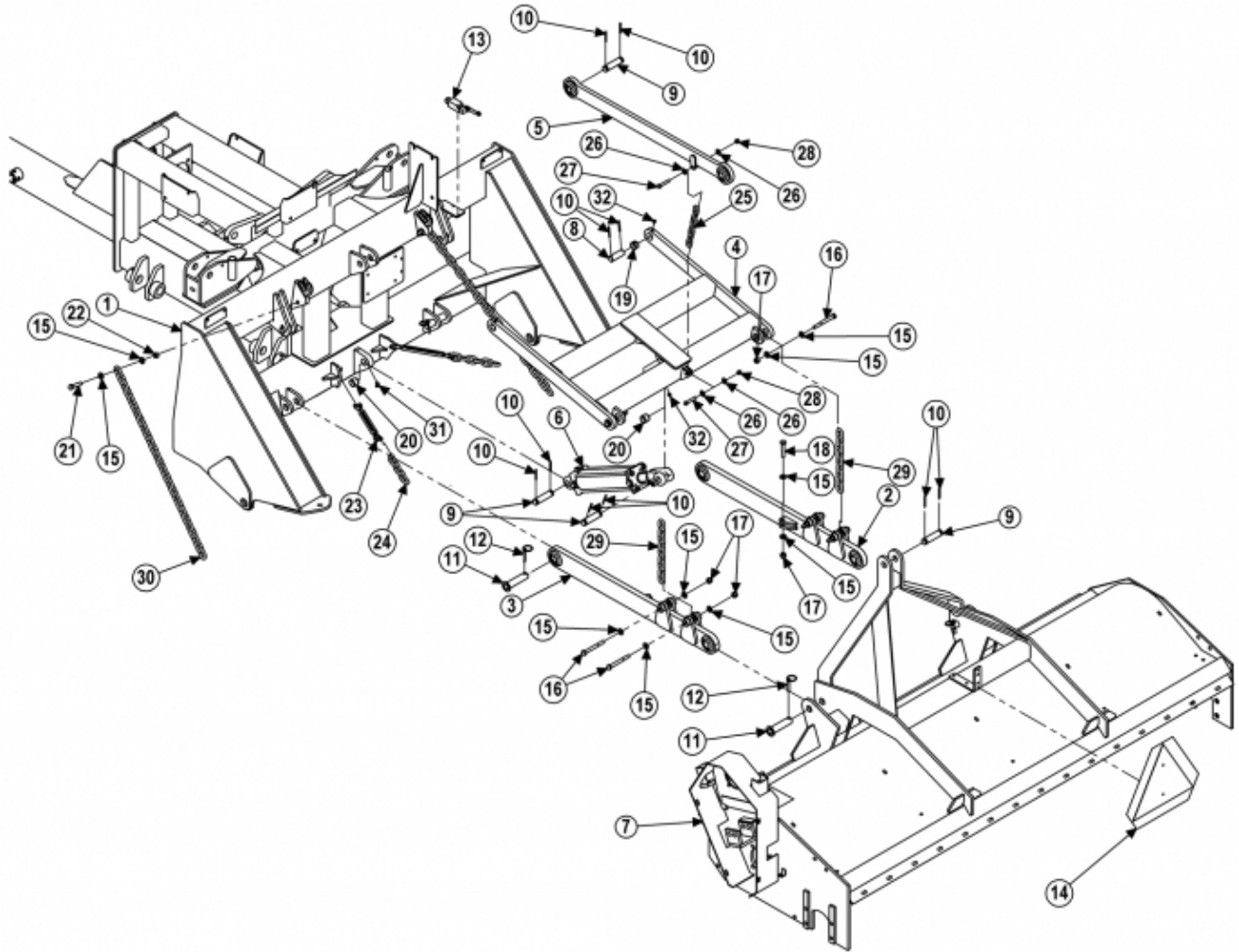

## TPF REAR MOWER MOUNT

Continued...

ITEM	PART NO.	QTY.	DESCRIPTION
1	06300333	1	MAINFRAME, TPF, 2 ED
2	06370233	1	ARM, LOWER, RH, TPF
3	06370243	1	ARM, LOWER, LH, TPF
4	06370244	1	LIFT, 3PNT, TPF
5	06370245	1	ARM, UPPER, TPF
6	6T1049	1	CYLINDER, 3X12
7	06320303	1	BONNET, 90, XD, TRF, TPF, CMPLT
8	06410230	2	PIN, 1.00,2.89, W/.19 HOLES
9	TB1033	4	PIN, CLEVIS, 1X4
10	06537021	12	ROLL PIN, 5MM X 50MM
11	TF1120	4	PIN, 1.13 X 4.27, CAP
12	TF1143	4	PIN, LYNCH, 7/16" X 2"
13	06510340	1	SWITCH, HARNESS, TILT, TPF2
14	23472	1	SMV SIGN
15	2200406	20	FLATWASHER, 1/2, SAE
16	21742	6	CAPSCREW, 1/2 X 4-1/2, NC
17	21727	8	NYLOCK NUT, 1/2, NC
18	21736	2	CAPSCREW, 1/2 X 2-3/4, NC
19	06520553	2	BUSHING, 1.25 X 1.00 X .75
20	TB3010	2	BUSHING 1
21	21734	2	CAPSCREW, 1/2 X 2-1/4, NC, GR8
22	6T2418	2	HEX NUT, 1/2 NC, GR8, (STOVER)
23	06520554	2	TURNBUCKLE, JAW X 2.38 X 11-1/2
24	06499017	2	CHAIN, 3/8 X 6LINK, GR43
25	06499025	1	CHAIN, 5/16, 7LINK, GR30
26	22016	4	FLATWASHER, 3/8, GR8
27	21635	2	CAPSCREW, 3/8 X 2-1/4, NC
28	21627	2	NYLOCK NUT, 3/8", NC
29	06499026	2	CHAIN, 3/8 X 9 LINKS, GR43
30	06520610	2	CHAIN, 3/8, GR40/43, 27 LINK
31	6T3210	1	GREASE ZERK, 1/8 X 90
32	6T3211	3	GREASE ZERK, 1/8 X STR

## TPF WHEEL ASSEMBLY

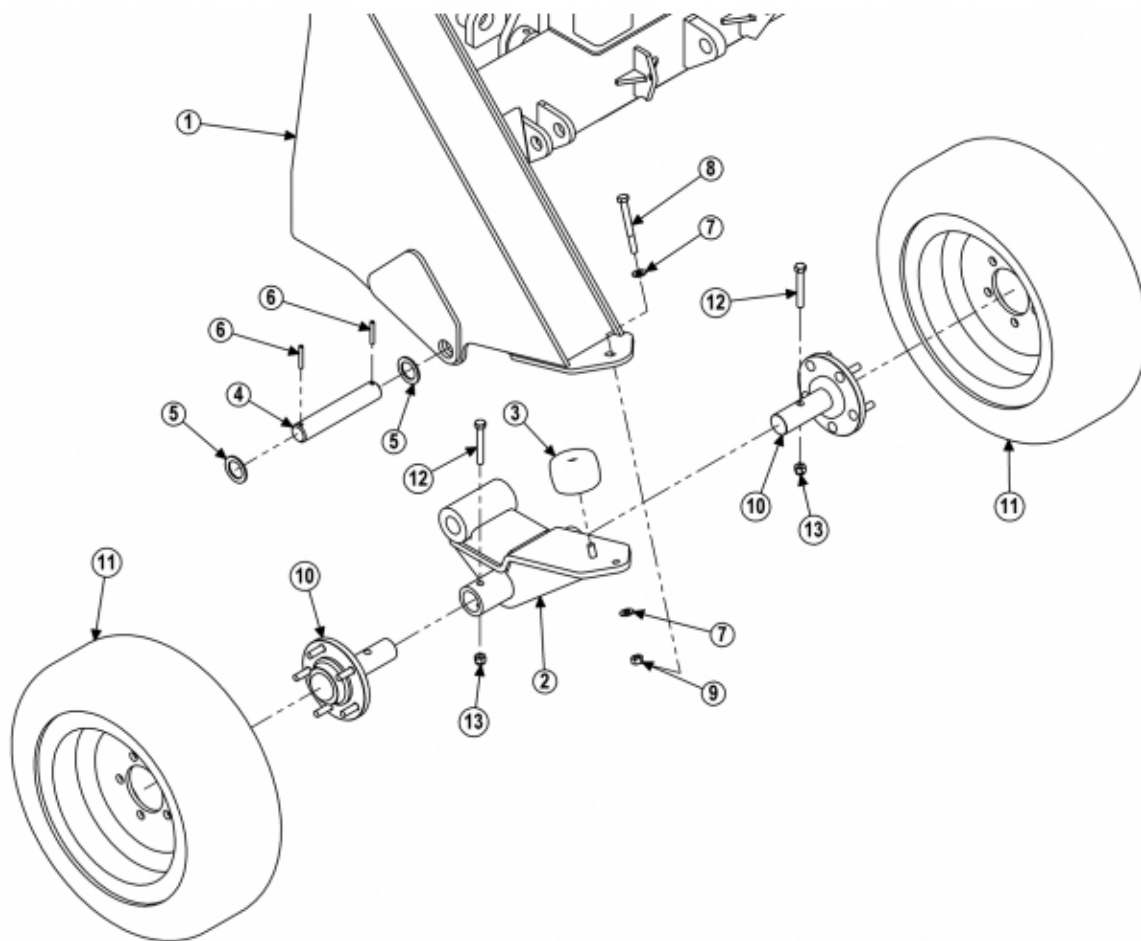

ITEM	PART NO.	QTY.	DESCRIPTION
1	06300333	1	MAINFRAME, TPF 2, ED
2	06300331	2	AXLE, TPF
3	00790205	2	PUCK, RUBBER, SUSPENSION
4	06420033	2	PIN, 1.50 X 8.63, LCKT, IT, KOMATSU
5	6T2617	4	BUSHING, MACH, 1-1/2 ID X 2-1/4 OD
6	6T3015	4	ROLL PIN, 5/16" X 2"
7	06533004	4	FLATWASHER, 1/2, SAE, GR8
8	21742	2	CAPSCREW, 1/2 X 4-1/2, NC
9	6T2418	2	HEX NUT, 1/2 NC, GR8, (STOVER)
10	00790220	4	ASY, HUB & SPINDLE - 5 BOLT
11	788719	4	TIRE, 25 8X8 0-18
12	21739	4	CAPSCREW, 1/2 X 3-1/2, NC
13	21727	4	NYLOCK NUT, 1/2, NC

**NOTES**

**NOTES**

## TPF HYDRAULICS

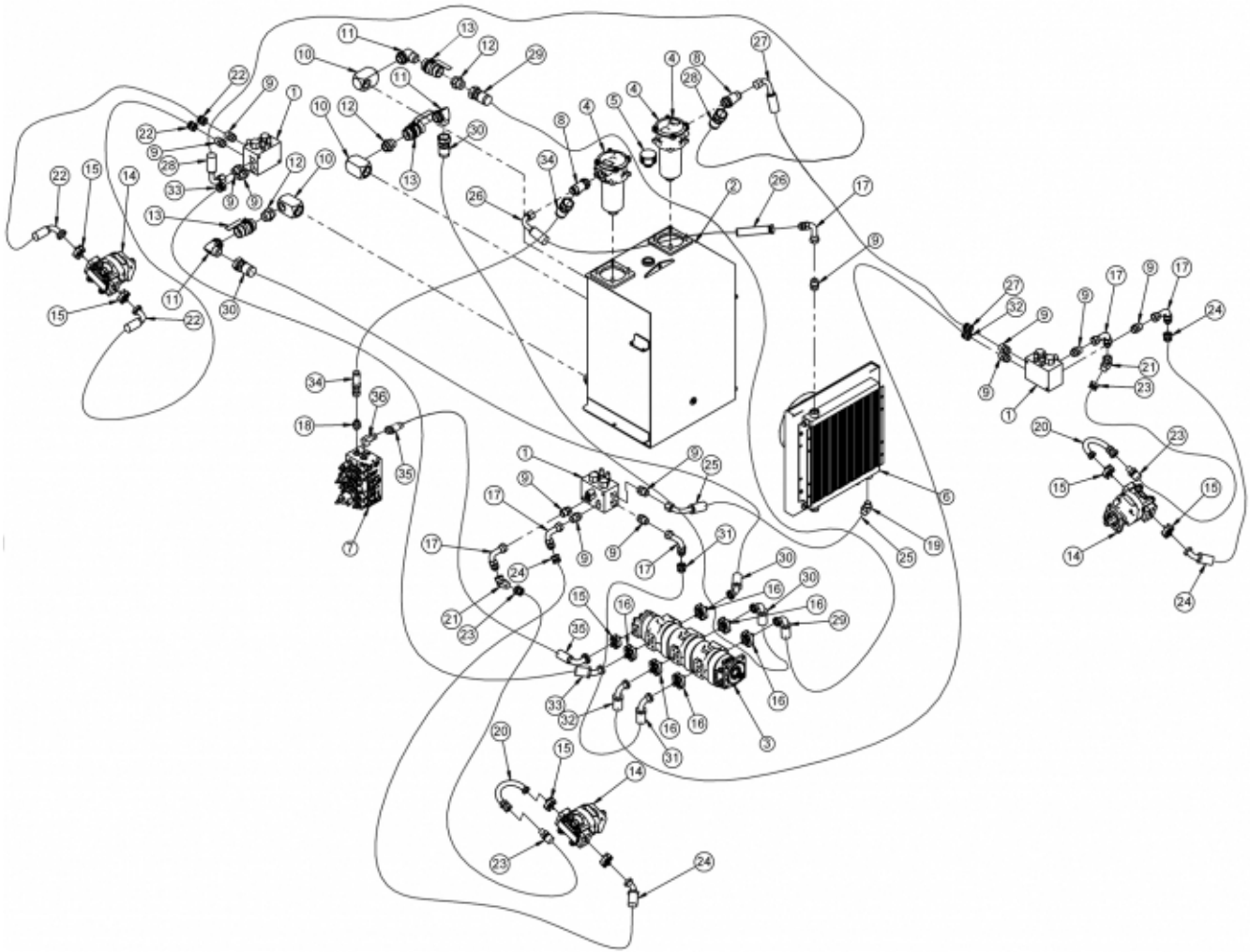

ITEM	PART NO.	QTY.	DESCRIPTION
1	06510083	3	BRAKE VALVE
2	06380091	1	TANK, RES, TPF 2
3	06504146	1	PUMP, TPF, QUAD
4	06505044	2	FILTER, ASSY, IN-TANK, CPLT, SAE 10
5	06505077	1	CAP, BREATHER, 1-5/8MB
6	06510301	1	COOLER, TPF
7	06510323	1	MANIFOLD, CONTROL, CNBS, TPF2
8	34656	2	TEE, RUN, 1-1/4ORB X 1-1/4MJ X 1-1/4MJ
9	33555	13	ADAPTER, 1MB X 1MJ
10	06503084	3	ELBOW, 1-1/2"FOR X 1-1/2"FOR, MACH
11	34655	3	ELBOW, 1-1/2"ORB X 1-1/2"MJ
12	34710	3	ADAPTER, 1-1/2"ORB X 1-1/2"MJ
13	34309	3	BALL VALVE 1-1/2" FOR
14	06504066	3	MOTOR, HD
15	06503174	1	KIT, FLANGE, #12

## TPF HYDRAULICS

Continued...

ITEM	PART NO.	QTY.	DESCRIPTION
16	TF4852	6	KIT, FLANGE #20
17	06503200	6	ELBOW, 16MJ X 16FJX, BT90
18	06503188	1	ADAPTER, 5/8"MB X 3/4" MJ
19	33554	1	ELBOW, 1"ORB X 1"FJX 45
20	32920	2	PREFORMED TUBE, 1"FJX X 16FLG
21	24724	2	SWIVEL, 1MJ X 1FJX 45
22	06500844	2	HOSE, 1" X 92"
23	06500970	2	HOSE, 1" X 63"
24	06500947	2	HOSE, 1" X 75"
25	06500949	1	HOSE, 1" X 17"
26	06500927	1	HOSE, 1" X 28"
27	06500837	1	HOSE, 1" X 59"
28	06500951	1	HOSE, 1" X 47"
29	06500840	1	HOSE, 1-1/2" X 27"
30	06500046	2	HOSE, 1-1/2" X 43"
31	06500651	1	HOSE, 1" X 30"
32	06500971	1	HOSE, 1" X 40"
33	06500836	1	HOSE, 1" X 45"
34	06500952	1	HOSE, 3/4" X 30"
35	06500925	1	HOSE, 3/4" X 35"
36	06503187	1	ELBOW, 5/8"MB X 3/4" MJ

## TPF HYDRAULICS - MOWERS

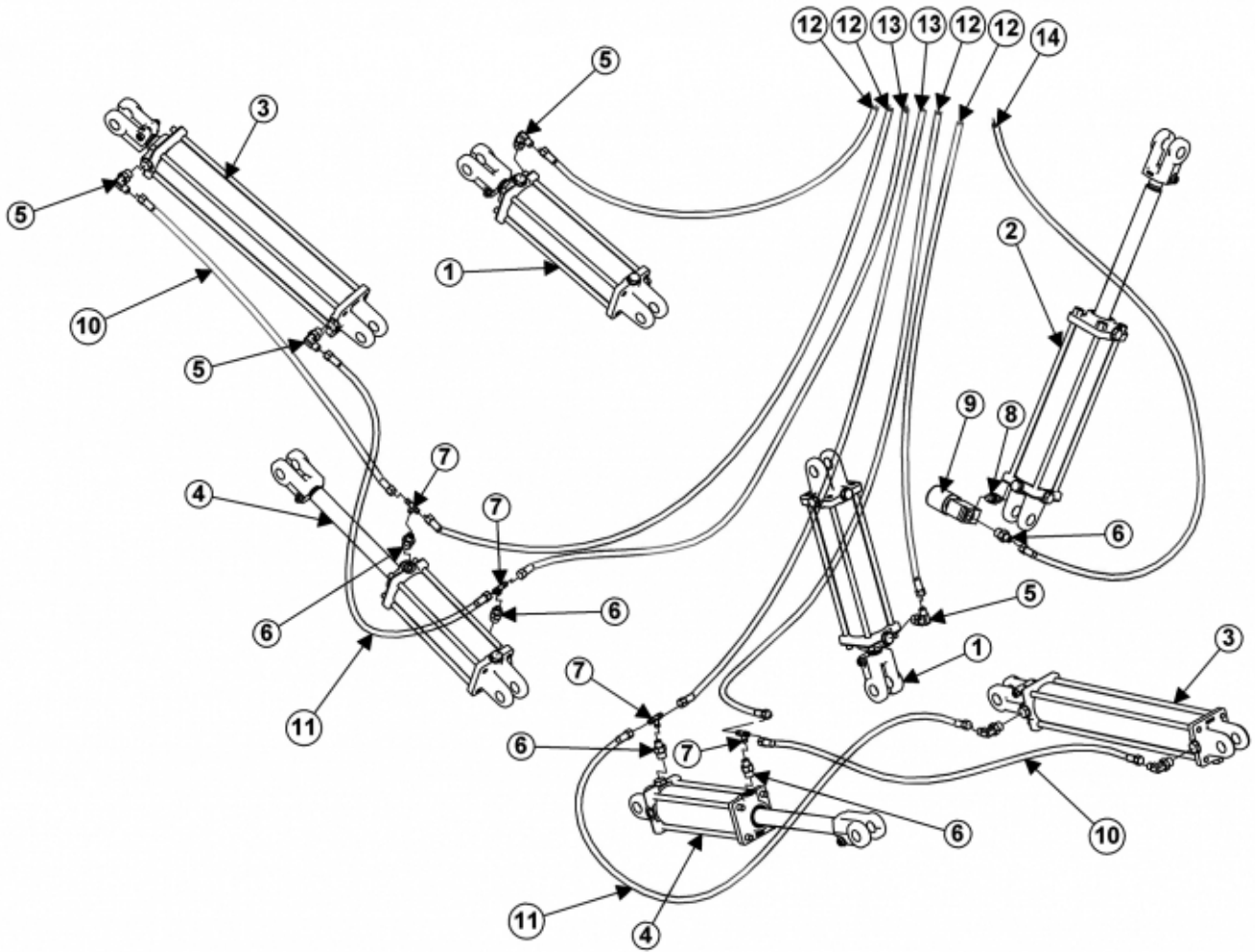

ITEM	PART NO.	QTY.	DESCRIPTION
1	6T0151R	2	CYLINDER, 3" X 10"
2	6T0149	1	CYLINDER, 3" X 12"
3	6T0150	2	CYLINDER, 3" X 18"
4	30481	2	CYLINDER, 3" X 8"
5	32810	6	ELBOW, 3/8" MJ X 1/2" MB, ADJ
6	33271	5	ADAPTER, 1/2" MOR X 3/8" MJ
7	34128	4	TEE, BRANCH, 3/8" MJ X 3/8" FJ X 3/8" MJ
8	31329	1	ADAPTER, 1/2" ORB X 1/2" ORB, ADJ
9	06510050	1	TRAVEL LOCK, METRIPACK COIL
10	06500848	2	HOSE, 1/4" X 46"
11	06500849	2	HOSE, 1/4" X 36"
12	06500973	4	HOSE, 1/4" X 61"
13	06500972	2	HOSE, 1/4" X 50"
14	33386	1	HOSE, 1/4" X 38"



# TPF HYDRAULIC DIAGRAM

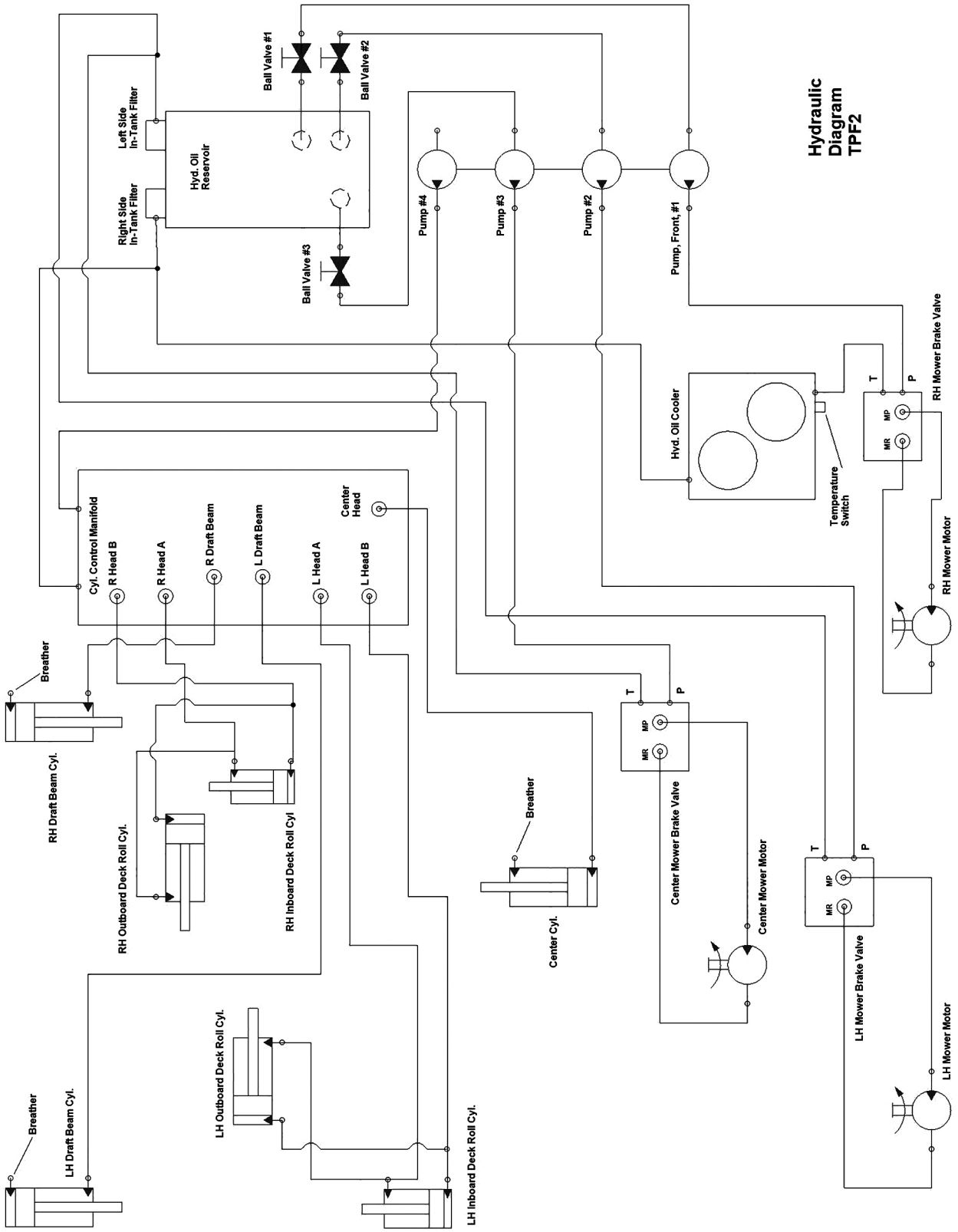

Hydraulic Diagram TPF2

# DRAFT BEAMS

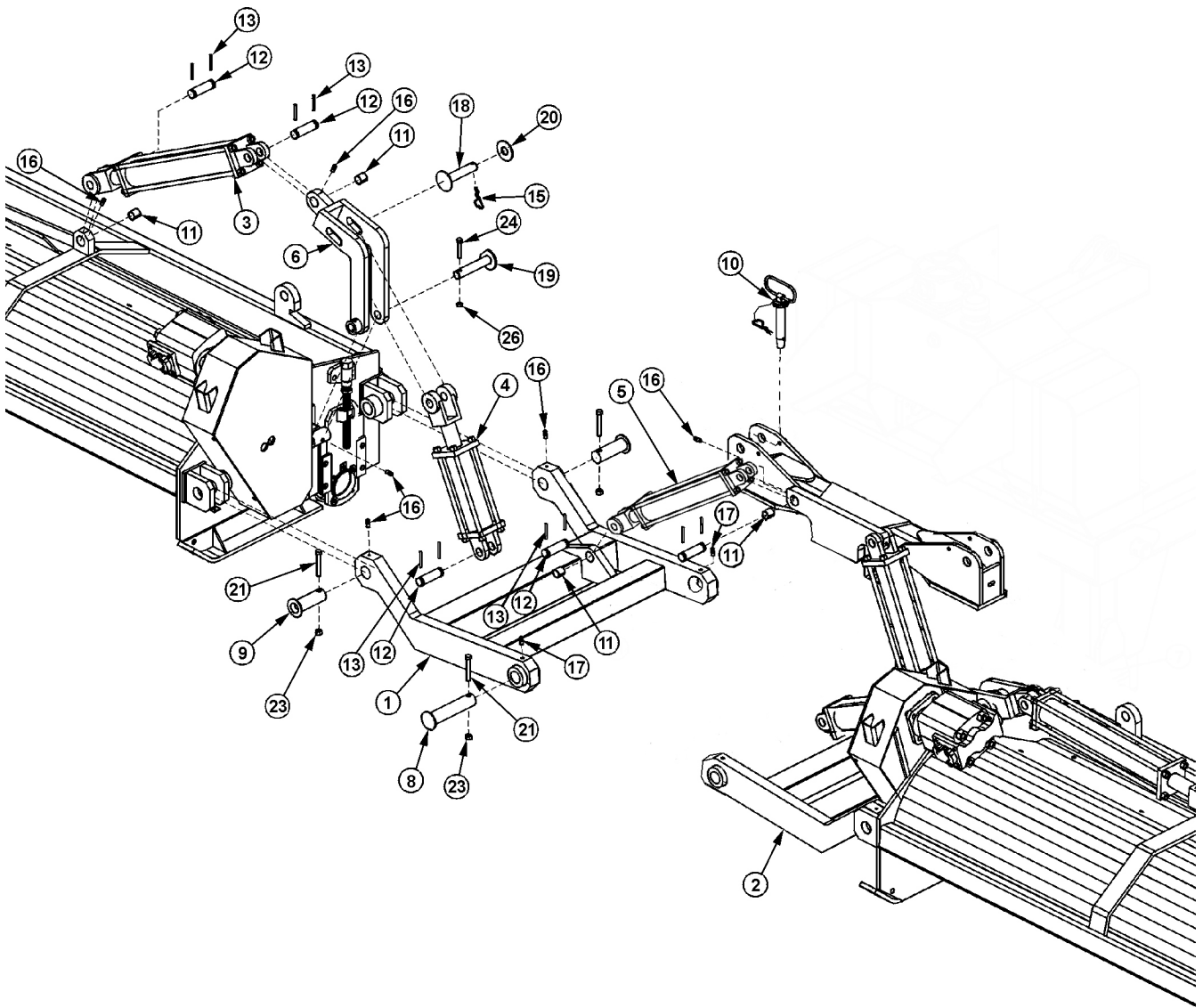

## DRAFT BEAMS

Continued...

ITEM	PART NO.	QTY.	DESCRIPTION
1	23700B	1	DRAFT BEAM,RIGHT
2	23706B	1	DRAFT BEAM,LEFT
3	6T0150	2	CYLINDER,DECK LIFT,OUTER
4	30481	2	CYLINDER,DECK LIFT,INNER
5	6T0151R	2	CYLINDER,DRAFT BEAM,LIFT
6	23833A	1	TILT LINK,RIGHT
7	23834A	1	TILT LINK,LEFT
8	TF4515	4	PIN,1-1/2",DRAFT BEAM TO MAIN FRAME
9	TF4514A	4	PIN,1-1/2",DRAFT BEAM TO HEAD
10	TF4250	2	PIN,TRAVEL LOCK W/ CHAIN
11	TB3010	9	BUSHING,1"
12	TB1033	12	CLEVIS PIN
13	6537021	22	ROLL PIN,5MM X 50MM,SS
15	6T3004	2	R-CLIP
16	6T3207	10	GREASE ZERK,1/4"
17	6T3211	12	GREASE ZERK,1/8"
18	23827C	2	PIN,1"
19	23829	2	PIN,1"
20	22023	2	FLATWASHER,1"
21	21688	8	CAPSCREW,7/16" X 3-1/4",NC
23	21677	8	NYLOCK NUT,7/16",NC
24	21635	2	CAPSCREW,3/8" X 2-1/4",NC
26	21627	2	NYLOCK NUT,3/8",NC
31	6T3210	1	GREASE ZERK,1/8" X 90°

## TPF MANIFOLD

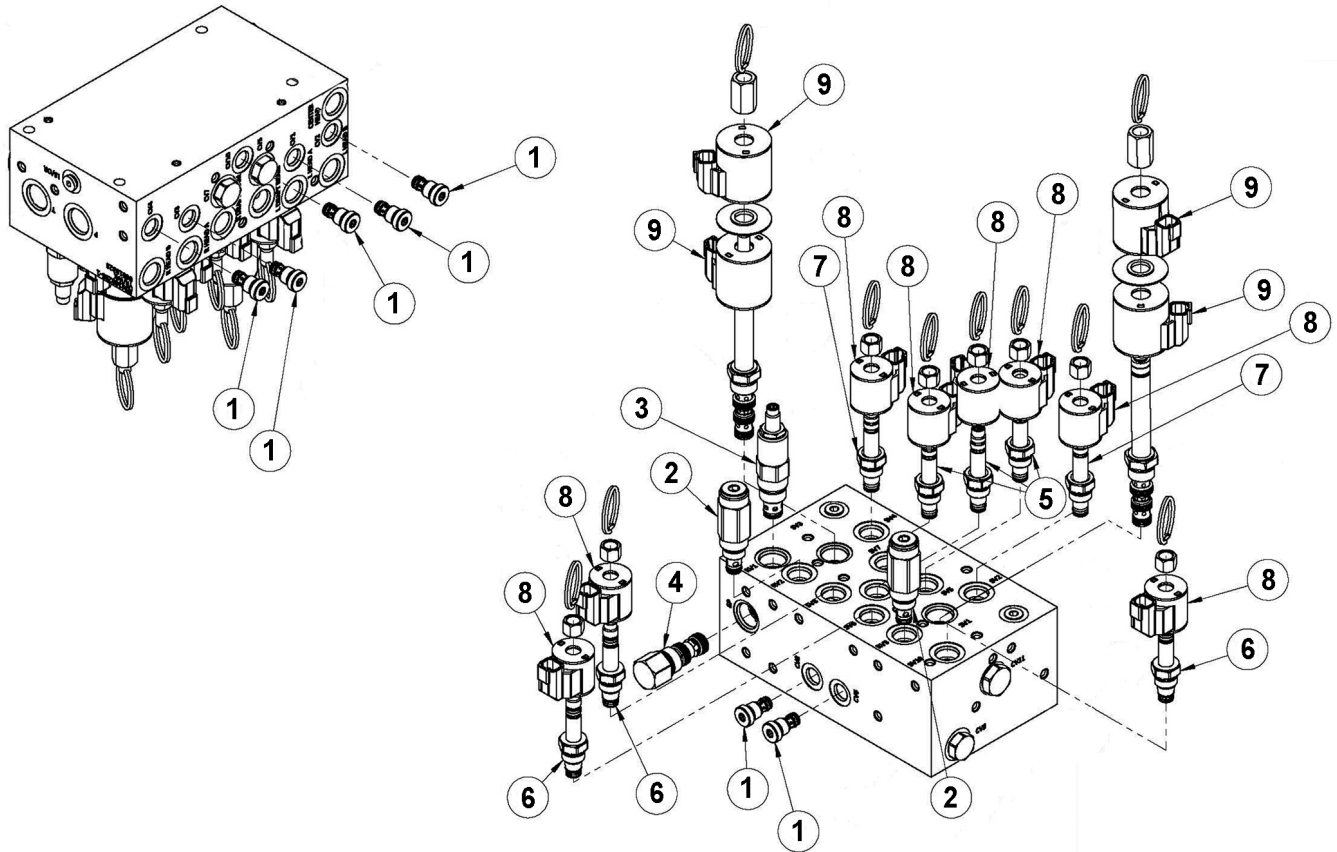

ITEM	PART NO.	QTY.	DESCRIPTION
1	06505353	7	CHECK, POPPET TYPE, NC
2	06505352	2	RELIEF VALVE
3	06505351	1	RELIEF VALVE, DIRECT ACTING, 2200 PSI
4	06505350	1	PILOT TO CLOSE SPOOL LOGIC
5	06505349	3	POPPET TYPE, 2-WAY, NC
6	06505348	3	2/2 PROP SOLENOID VALVE
7	06505347	2	POPPET TYPE, 2-WAY, NC
8	06505346	8	12 VDC, -08 SIZE E-COIL
9	06505345	4	12 VDC, -10 SIZE E-COIL

# NOTES

# TPF WIRE HARNESS - TRACTOR

**#6T3927  
CONTINUOUS DUTY  
SOLENOID**



**FUSE HOLDER**



**BATTERY +**  
Battery Pos.  
(+) Terminal

**BATTERY -**  
Battery Neg.  
(-) Terminal

**TERMINATOR**



**AUXILIARY  
POWER/  
IGNITION**



**#06510320  
TRACTOR  
HARNESS**



**KEYPAD  
#06510318**

**TRACTOR SIDE  
DISCONNECT**



# TPF WIRE HARNESS - TRAILER

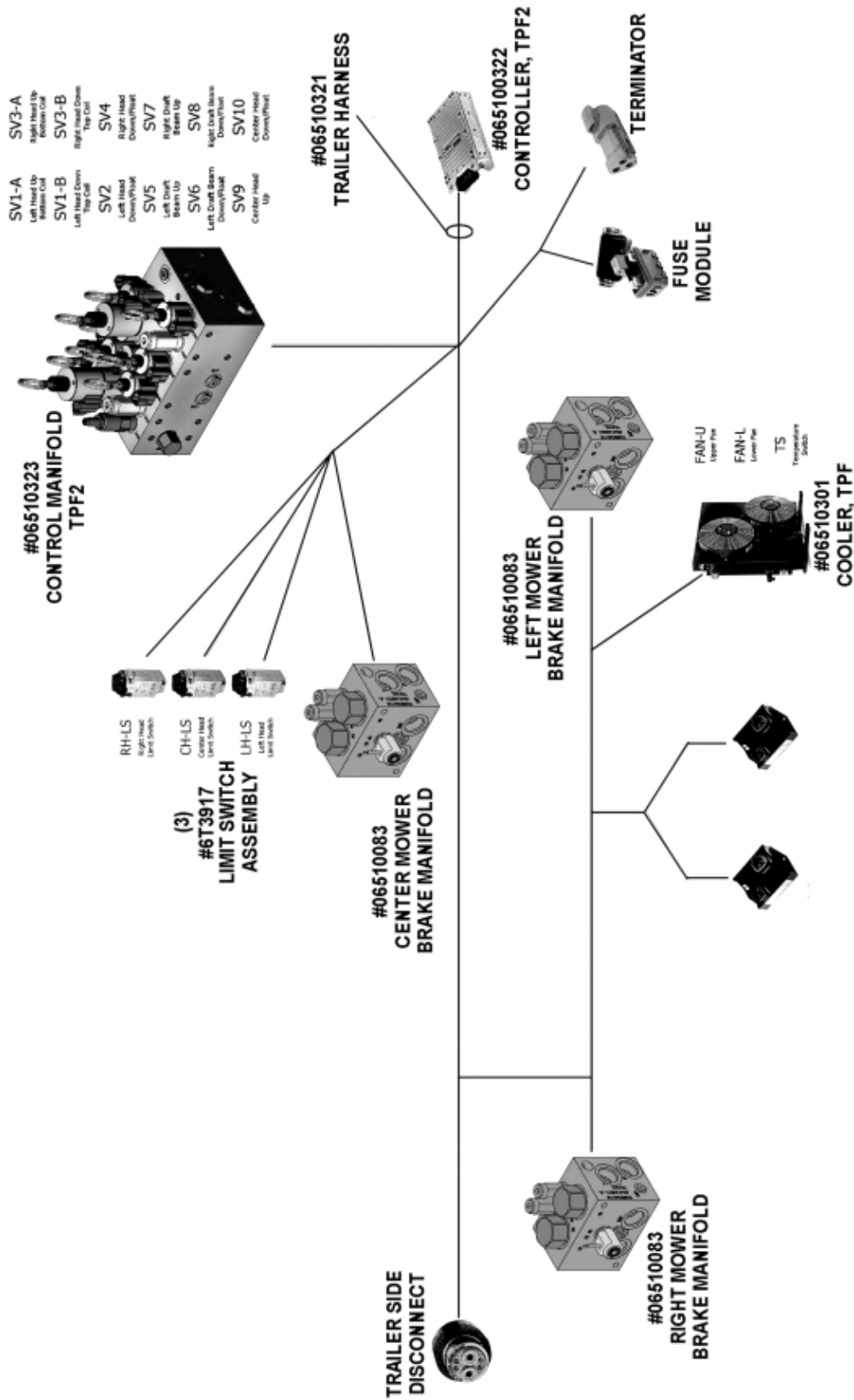

## 75IN SIDE MOWER ASSEMBLY

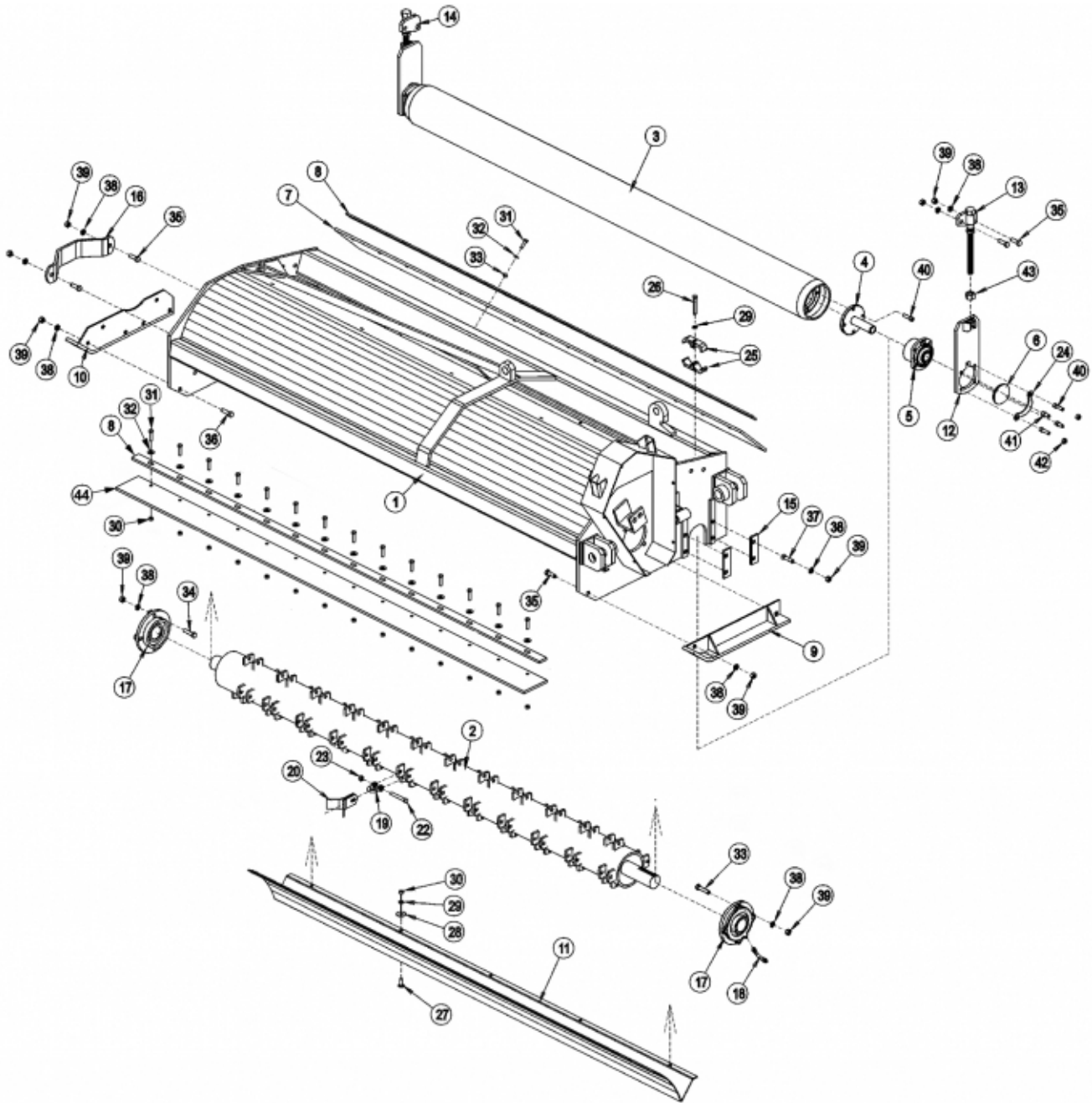

ITEM	PART NO.	QTY.	DESCRIPTION
1	06320300	1	CUTTER HEAD,RH
1A	06320301	1	CUTTER HEAD,LH (NOT PICTURED)
2	TF1002	1	CUTTER SHAFT
3	06320236	1	GROUND ROLLER
4	TF1045B	2	GROUND ROLLER STUB SHAFT
5	TF1022S	2	FLANGE BEARING
6	TF1041	2	DUST CAP



## 75IN SIDE MOWER ASSEMBLY

Continued...

ITEM	PART NO.	QTY.	DESCRIPTION
7	TF1016	1	DEFLECTOR FLAP
8	TF1029	1	FLAP RETAINING BAR
9	TF4365	1	RH SKID SHOE,INNER
9A	TF4366	1	LH SKID SHOE,INNER (NOT PICTURED)
10	TF4371	1	RH SKID SHOE,OUTER
10A	TF4370	1	LH SKID SHOE,OUTER (NOT PICTURED)
11	TF1402A	1	BAFFLE
12	TF4333A	2	ADJUSTABLE ROLLER BRACKET
13	TF4335	1	LEFT ADJUSTMENT ROD
14	TF4334	1	RIGHT ADJUSTMENT ROD
15	TF4336	4	GROUND ROLLER LOCK PLATE
16	TF1040	1	CUTTER SHAFT END GUARD
17	TF1018	2	FLANGE BEARING
18	TF1036	1	GREASE HOSE
19	TF1020	48	KNIFE MOUNTING CLEVIS
20	33714	96	STANDARD CUT FLAIL KNIFE
22	TF1021B	48	KNIFE MOUNTING BOLT
23	21677	48	NYLOCK NUT
24	30565	2	BEARING CAP KEEPER
25	TB3031	2	DOUBLE TUBE CLAMP
26	21638	1	CAPSCREW,3/8" X 3",NC
27	6T2283	10	CARIAGE BOLT,3/8" X 1",NC
28	6T2615	10	FENDER WASHER,3/8"
29	21988	11	LOCKWASHER,3/8"
30	21625	40	HEX NUT,3/8",NC
31	21631	30	CAPSCREW,3/8" X 1",NC
32	22016	30	FLATWASHER,3/8"
33	21734	4	CAPSCREW,1/2" X 2-1/4",NC
34	21733	4	CAPSCREW,1/2" X 2",NC
35	21731	8	CAPSCREW,1/2" X 1-1/2",NC
36	21730	6	CAPSCREW,1/2" X 1-1/4",NC
37	23293	8	PLOWBOLT,1/2" X 2",NC
38	21990	30	LOCKWASHER,1/2"
39	21725	30	HEX NUT,1/2"
40	6T2330	12	CAPSCREW,7/16" X 1-1/2",NC,SKT HD
41	6T2331	4	CAPSCREW,7/16" X 1",NC,SKT HD
42	24701	4	HEX NUT,7/16",NC,STOVER
43	TF4340	2	HEX NUT,3/4",NC,ACME
44	06520242	1	FLAP, FRONT, 75"

# 90IN REAR MOWER - STANDARD ROTATION

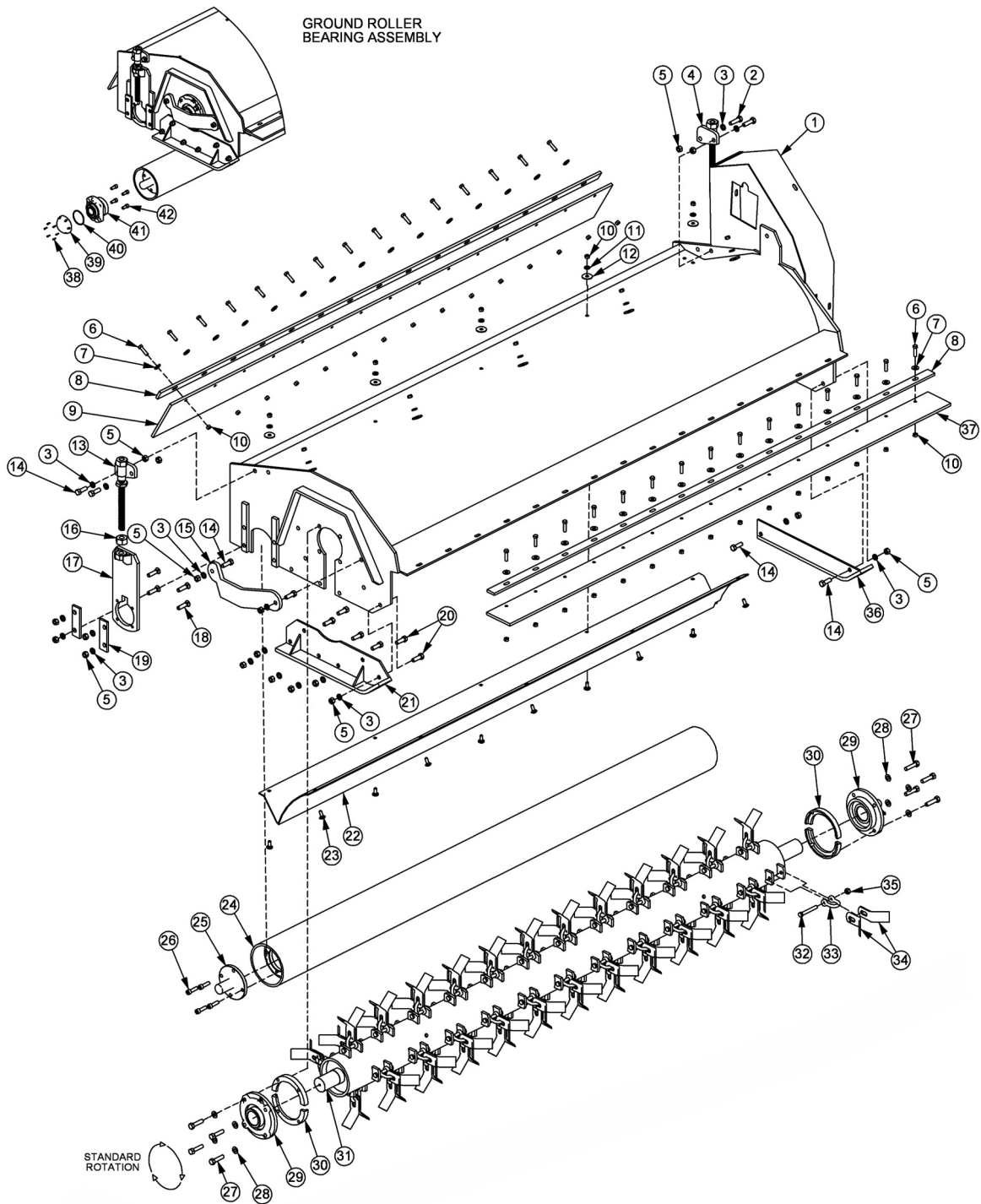

ITEM	PART NO.	QTY.	DESCRIPTION
1	06320303	1	BONNET,90",HD
2	21732	2	CAPSCREW,1/2" X 1-3/4",NC
3	21990	22	LOCKWASHER,1/2"
4	TF4335	1	ROD,GROUND ROLLER ADJ,LF

## 90IN REAR MOWER - STANDARD ROTATION

Continued...

ITEM	PART NO.	QTY.	DESCRIPTION
5	21725	22	HEX NUT,1/2",NC
6	21632	36	CAPSCREW,3/8" X 1-1/2",NC
7	22016	36	FLATWASHER,3/8"
8	TF1135	2	BAR,FLAP,TSF/TRF,90"
9	TF1116	1	FLAP,DEFLECTOR,TSF/TRF,90"
10	21625	46	HEX NUT,3/8",NC
11	21988	10	LOCKWASHER,3/8"
12	6T2615	10	WASHER,FENDER,3/8"
13	TF4334	1	ROD,GROUND ROLLER ADJ,RT
14	21731	6	CAPSCREW,1/2" X 1-1/2",NC
15	TF1040	1	GUARD,CUTTERSHAFT
16	21399	2	HEX NUT,3/4",ACME THRD
17	TF4333A	2	GROUND ROLLER ADJ BRKT
18	6T2294	8	PLOW BOLT,1/2" X 2",NC
19	TF4336	4	PLATE,GROUND ROLLER LOCK
20	21730	6	CAPSCREW,1/2" X 1-1/4",NC
21	TF4371	1	SKID SHOE,L/PROFILE-OUTER
22	TF1502A	1	BAFFLE,FLAIL,90",HD
23	6T2283	10	CARRIAGE BOLT,3/8" X 1",NC
24	06320237	1	GROUND ROLLER,90"
25	TF1045B	2	GRND ROLLER STUB SHAFT
26	6T2330	8	CAPSCREW,7/16" X 1-1/2", SKT HD
27	06530217	8	CAPSCREW,1/2" X 2",NC,L9
28	06533006	8	FLATWASHER,1/2",SAE,L9
29	TF1018	2	BEARING,FLANGE,2-3/16"
30	31204	2	STRING GUARD,HD
31	TF1102	1	CUTTERSHAFT,90",HD
32	34011	48	KNIFE MOUNTING BOLT,FLAIL
33	TF1020	48	KNIFE MTG CLEVIS,FLAIL
34	33714	96	KNIFE,FLAIL,STANDARD CUT
35	21677	48	NYLOCK NUT,7/16",NC
36	TF4365	1	SKID SHOE,L/PROFILE-INNER
37	06520243	1	FLAP,FRONT,90"
38	06530001	12	CAPSCREW,SKT HD
39	06520027	2	CAP,BEARING
40	06520029	2	O-RING,2-3/4" X 3/32"
41	06520028	2	BEARING,FLANGE,1-3/8"
42	6T2331	8	CAPSCREW,7/16" X 1",SKT HD

# SIDE AND REAR MOWER DRIVE ASSEMBLY

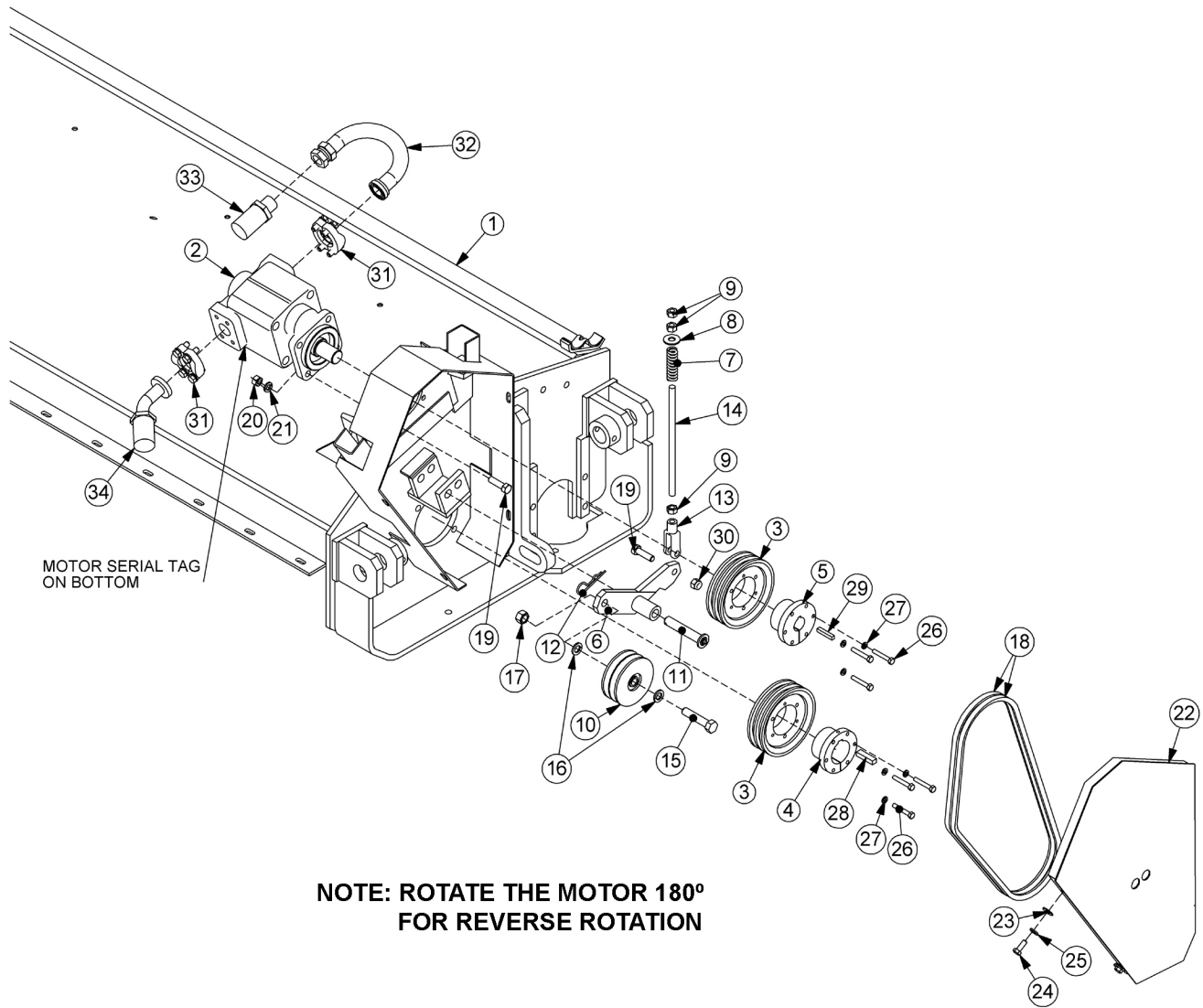

## SIDE AND REAR MOWER DRIVE ASSEMBLY

Continued...

ITEM	PART NO.	QTY.	DESCRIPTION
1	-----	-	BONNET *REFER TO FLAIL PARTS
2	06504066	1	MOTOR,T3F
3	TF3040	2	SHEAVE,6.3"
4	TF3011	1	BUSHING,QD,SK,2-3/16"
5	TF3013	1	BUSHING,QD,SK,1-1/4"
6	TF4346	1	IDLER ARM (RIGHT FLAIL - STD ROT / LEFT FLAIL - REV ROT)
---	TF4345	1	IDLER ARM (RIGHT FLAIL - REV ROT / LEFT FLAIL - STD ROT) (NOT SHOWN)
7	TF3620A	1	SPRING,TENSIONER
8	22018	1	FLATWASHER,1/2",WIDE
9	21700	3	HEX NUT,1/2",NF
10	31293	1	SHEAVE,IDLER ASSY,4.4" O.D.
11	TF3605	1	PIN,IDLER ARM 3/4" X 4-1/4"
12	6T3004	1	R-CLIP (HAIRPIN COTTER, 3/16")
13	PT3611A	1	CLEVIS,6"
14	32494	1	ROD, THREADED,1/2-20,NF
15	21787	1	CAPSCREW,5/8" X 3",NC
16	21992	2	LOCKWASHER,5/8"
17	21775	1	HEX NUT,5/8",NC
18	TF3020	2	V-BELT,530
19	21732	5	CAPSCREW,1/2" X 1-3/4",NC
20	21725	4	HEX NUT,1/2",NC
21	21990	4	LOCKWASHER,1/2"
22	TF4564	1	BELT SHEILD,RIGHT
---	TF4565	1	BELT SHEILD,LEFT
23	22016	4	FLATWASHER,3/8"
24	21630	4	CAPSCREW,3/8" X 1",NC
25	21988	4	LOCKWASHER,3/8"
26	21584	6	CAPSCREW,5/16" X 2",NC
27	21987	6	LOCKWASHER,5/16"
28	TF1025	1	KEY,1/4" X 1/2" X 1-7/8",SQ
29	TF1125	1	KEY,3/8" X 1/2" X 1-7/8",SQ
30	21727	1	NYLOCK NUT,1/2",NC
31	TF4853	2	KIT,FLANGE,#16
32	32920	1	PREFORMED TUBE (SIDE MOWER ONLY)
33	06500842	1	HOSE (PRESSURE--SIDE MOWER)
34	06500841	1	HOSE (RETURN--SIDE MOWER)
--	06500844	2	HOSE (PRESSURE & RETURN) REAR MOWER



## SIDE MOWER MOTOR BREAKDOWN

Continued...

ITEM	PART NO.	QTY.	DESCRIPTION
-----	06504066	-	MOTOR ASSEMBLY 350 - TSF
1	06504039	1	SHAFT END COVER
2	06504054	1	PORT END COVER
3	06504055	1	GEAR HOUSING
4	06504056	1	MATCHED GEAR SET
5	TF4402	1	BALL BEARING
6	06504057	4	CAP SCREW
7	06504044	2	SET SCREW
9	06504045	4	DOWEL PIN
10	-----	1	NAMEPLATE
11	763759	2	THRUSTPLATE
12	02961940	1	HEX PLUG
13	TF4401	1	SNAP RING
14	06504049	1	LIP SEAL (INCLUDED IN SEAL KIT)
15	TF4410	2	GASKET SEAL (INCLUDED IN SEAL KIT)
16	06504046	4	SIDE SEAL (INCLUDED IN SEAL KIT)
17	06504047	4	END SEAL (INCLUDED IN SEAL KIT)
18	TF4407	2	BACK-UP SEAL (INCLUDED IN SEAL KIT)
19	02961932	1	SEAL RETAINER
20	6T5809	2	CHECK ASSEMBLY
21	02961917	4	WASHER
-----	06504023	-	SEAL KIT (INCLUDES 14, 15, 16, 17, AND 18)

## 06510083 BRAKE VALVE ASSEMBLY

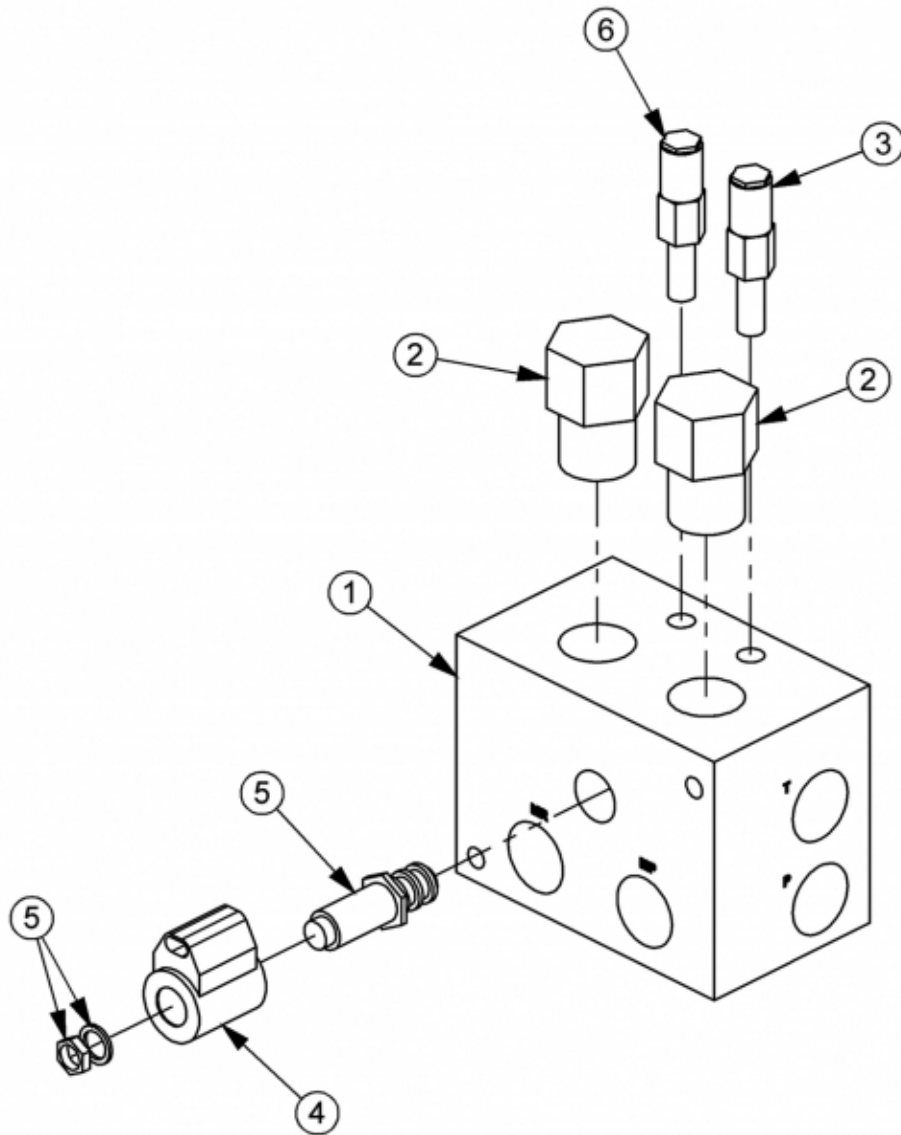

ITEM	PART NO.	QTY.	DESCRIPTION
---	06510083	1	BRAKE VALVE, ASSY
1	34092	1	BRAKE VALVE, BLANK
2	34094	2	LOGIC ELEMENT
3	34095	1	RELIEF VALVE, 3000 PSI
4	06510095	1	METRI PAK COIL
5	34093	1	CARTRIDGE, 2 POSITION, 3 WAY (WITH NUT & WASHER)
6	34091	1	RELIEF VALVE, 2600 PSI
---	34096	2	RELIEF SEAL KIT
----	34097	1	SOLENOID SEAL KIT
---	34098	2	ELEMENT SEAL KIT



PTO BREAKDOWN 00791764

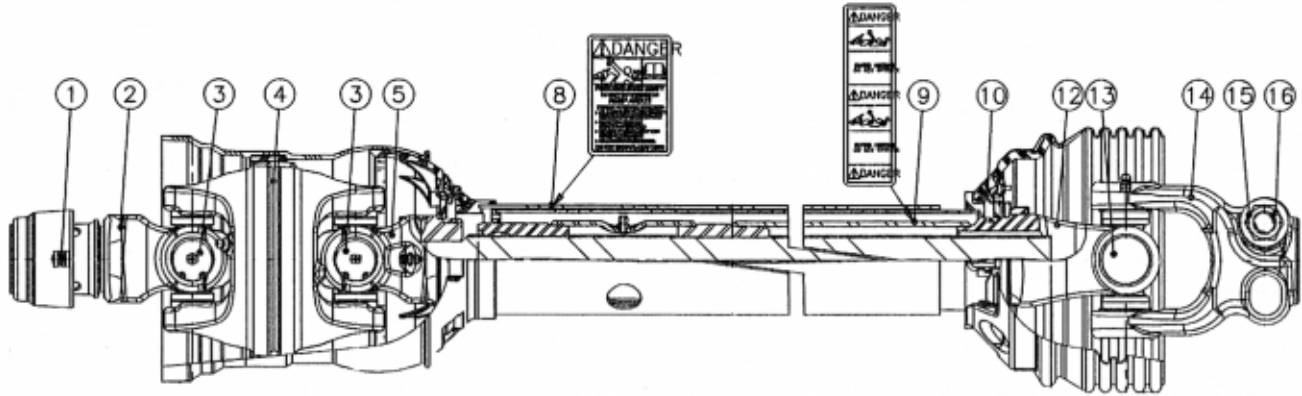

ITEM	PART NO.	QTY.	DESCRIPTION
1	2716820	1	REPAIR KIT, SSL/AUTO-LOK
2	50069188	1	YOKE, 4 80 WWCV, AUTO-LOK
3	50069189	2	CROSS KIT, AB6/AW22/480 EBL
4	00788000	1	CENTER HOUSING, 4 80 WWCV
5	00791766	1	YOKE & SHAFT
8	00756005	1	SAFETY SIGN
9	00756004	1	SAFETY SIGN
10	00779051	1	GUARD REPAIR KIT
12	00791767	1	YOKE, TUBE & SLIP SLEEVE
13	00779519	1	CROSS KIT, 44EBL
14	00779518	1	YOKE, 44
15	5HR10110	1	LOCK NUT, FLANGE, 5/8-11, GRADE G
16	00785001	1	BOLT, 5/8-11 X 3.50, GD8, FLG HEAD

# 3IN X 10IN HYDRAULIC CYLINDER BREAKDOWN

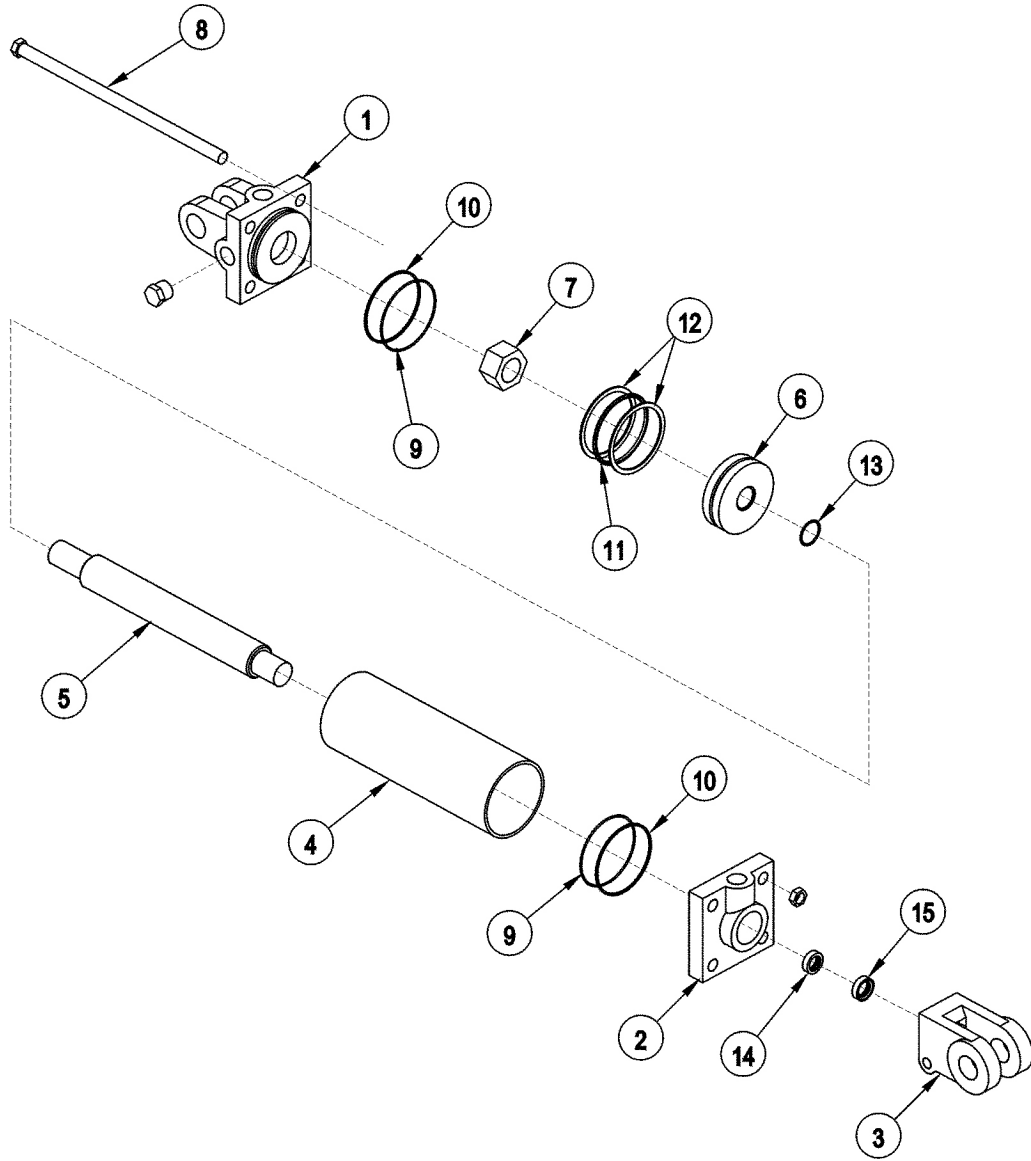

## 3IN X 10IN HYDRAULIC CYLINDER BREAKDOWN

Continued...

ITEM	PART NO.	QTY.	DESCRIPTION
---	6T0151R	1	CYLINDER 3" X 10"
1	6T0167	1	CYLINDER BUTT
2	6T0170	1	CYLINDER GLAND
3	6T0178	1	CLEVIS END
4	6T0164	1	CYLINDER TUBE
5	6T0161	1	PISTON ROD
6	6T0173	1	PISTON
7	6T0179	1	LOCKNUT
8	6T0176	4	TIE ROD ASY
---	6T0187	1	SEAL KIT
9	-----	2	O - RING
10	-----	2	BACK - UP WASHER
11	-----	1	O - RING
12	-----	2	BACK - UP WASHER
13	-----	1	O - RING
14	-----	1	U - CUP
15	-----	1	WIPER
16	NA	-	NA

# 3IN X 18IN HYDRAULIC CYLINDER BREAKDOWN

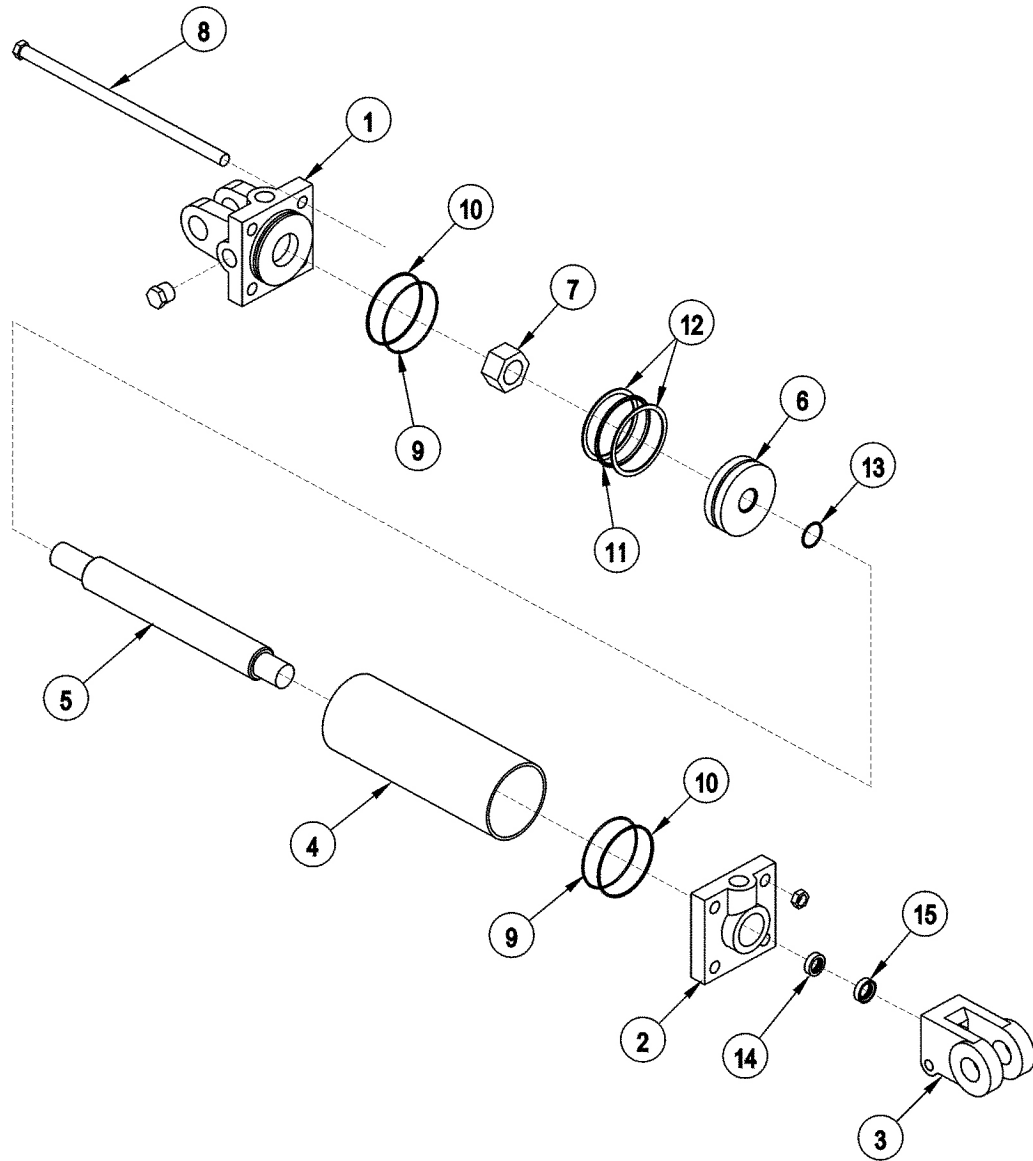

## 3IN X 18IN HYDRAULIC CYLINDER BREAKDOWN

Continued...

ITEM	PART NO.	QTY.	DESCRIPTION
---	6T0150	1	CYLINDER 3" X 18"
1	6T0167	1	CYLINDER BUTT
2	6T0170	1	CYLINDER GLAND
3	6T0178	1	CLEVIS END
4	6T0165	1	CYLINDER TUBE
5	6T0162	1	PISTON ROD
6	6T0173	1	PISTON
7	6T0179	1	LOCKNUT
8	6T0177	4	TIE ROD ASY
---	6T0187	1	SEAL KIT
9	-----	2	O - RING
10	-----	2	BACK - UP WASHER
11	-----	1	O - RING
12	-----	2	BACK - UP WASHER
13	-----	1	O - RING
14	-----	1	U - CUP
15	-----	1	WIPER
16	N/A	-	N/A

# 3IN X 8IN HYDRAULIC CYLINDER BREAKDOWN

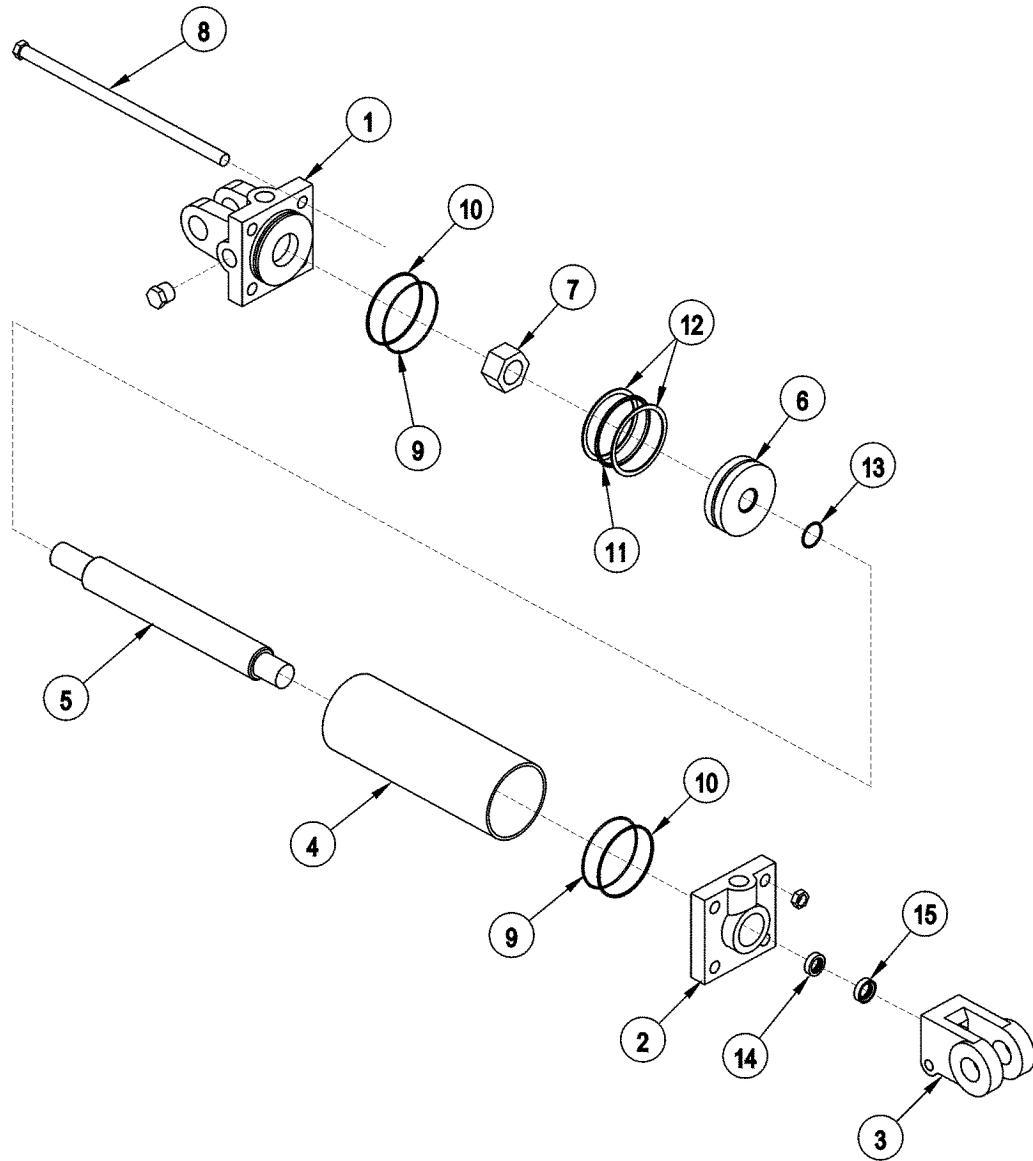

## 3IN X 8IN HYDRAULIC CYLINDER BREAKDOWN

Continued...

ITEM	PART NO.	QTY.	DESCRIPTION
---	30481	1	CYLINDER 3" X 8"
1	6T0167	1	CYLINDER BUTT
2	6T0170	1	CYLINDER GLAND
3	6T0178	1	CLEVIS END
4	23870	1	CYLINDER TUBE
5	23869	1	PISTON ROD
6	6T0173	1	PISTON
7	6T0179	1	LOCKNUT
8	23871	4	TIE ROD ASY
---	6T0187	1	SEAL KIT
9	-----	2	O - RING
10	-----	2	BACK - UP WASHER
11	-----	1	O - RING
12	-----	2	BACK - UP WASHER
13	-----	1	O - RING
14	-----	1	U - CUP
15	-----	1	WIPER
16	N/A	-	N/A

# NOTES



# **WARRANTY SECTION**



## WARRANTY INFORMATION

Tiger Corporation, 3301 N. Louise, Sioux Falls, South Dakota, warrants to the original Retail Customer, the new Tiger equipment is free of defects in material and workmanship. Any part of equipment that in Tiger's judgement, show evidence of such defects will be repaired or replaced without charge, provided that the failure of part(s) shall have occurred within twelve (12) months from the date of delivery of said equipment to the Retail Customer. Expendable components such as knives, oil, chain sprockets, skid shoes, knife mounting disks and the like are excluded but not limited to this warranty.

The Retail Customer must pay the transportation cost to and from the Tiger Dealer's service shop for warranty service. Warranty service will be performed by the Tiger Dealer from whom the equipment was purchased, during service shop regularly scheduled days and hours of operation.

All Tiger obligation under this warranty shall be terminated if the equipment is modified or altered in ways not approved in writing by Tiger, if repair parts other than genuine Tiger repair parts have been used, or if the equipment has been subject to misuse, neglect, accident, improper maintenance or improper operation.

Tiger Corporation reserves the right to make improvements in design or changes in specification at any time without incurring any obligation to owners of equipment previously sold.

No agent or person has authority to alter, add to or waive the above warranties which are agreed to be in the only warranties, representations or promises, expressed or implied, as to the quality or performance of the products covered and which do not include any implied warranty of merchantability or fitness. In no event will Tiger be liable for incidental or consequential damages or injuries, including, but not limited to, loss of profits, rental or substitute equipment or other commercial loss.

**THERE ARE NO WARRANTIES WHICH EXTEND  
BEYOND THOSE EXPRESSED HEREIN.**

It is the Purchasers obligation to sign the warranty registration form **AFTER** he / she has Read and Understands the Operation and Safety Instructions stated within this manual.

## **ONE LAST WORD**

This manual cannot possibly cover all of the potentially hazardous situations you will encounter. By being familiar with the safety rules, operating and maintenance instructions in this manual you can help prevent accidents. The objective of this manual is to help make you a better operator. Remember, **SAFETY IS YOU!**



1012

Your safety and the safety of those around you depends on **YOU**. Common sense should play a large role in the operation of this machine.

Since we at Tiger Corporation are constantly striving to improve our products, we reserve the right to change specifications or design at any time.

## TO THE OWNER / OPERATOR / DEALER



To keep your implement running efficiently and safely, read your manual thoroughly and follow these directions and the Safety Messages in this manual and on the machine. The table of contents clearly identifies each section where you can easily find the information you need.

The Occupational Safety and Health Act (OSHA 1928.51 subpart C) makes the following minimum requirements for tractor operators.

### **OWNER REQUIREMENTS:**

1. Provide a Roll-Over-Protective Structure that meets the requirements of this Standard; and
2. Provide Seatbelts that meet the requirements of this Standard and SAE J3C; and
3. Ensure that each employee uses such Seatbelt while the tractor is moving; and
4. Ensure that each employee tightens the Seatbelt sufficiently to confine the employee to the protected area provided by the ROPS.

### **OPERATOR REQUIREMENTS:**

1. Securely fasten seatbelt if the tractor has a ROPS.
2. Where possible, avoid operating the tractor near steep ditches, embankments, and holes.
3. Reduce speed when turning, crossing slopes, and on rough, slick, or muddy surfaces.
4. Stay off slopes too steep for safe operation.
5. Watch where you are going – especially at row ends, on roads, and around trees.
6. Do Not permit others to ride.
7. Operate the tractor smoothly – no jerky turns, starts, or stops.
8. Hitch only to the draw-bar and hitch points recommended by the tractor manufacturer.
9. When the tractor is stopped, set brakes securely and use park lock, if available



Printed in USA  
© Tiger Corporation