



Current as of 12/19/2011

TruckKat® 2011 TIER 3 Truck Mounted Boom Mower



PARTS LISTING WITH SAFETY AND OPERATING INSTRUCTIONS

Tiger Corporation
3301 N. Louise Ave.
Sioux Falls, SD 57107
1-800-843-6849
1-605-336-7900

06030006

TO THE OWNER / OPERATOR / DEALER





All implements with moving parts are potentially hazardous. There is no substitute for a cautious, safe-minded operator who recognizes the potential hazards and follows reasonable safety practices. The manufacturer has designed this implement to be used with all its safety equipment properly attached to minimize the chance of accidents.

BEFORE YOU START!! Read the safety messages on the implement and shown in this manual. Observe the rules of safety and use common sense!

READ AND UNDERSTAND THIS MANUAL! Spanish or other language speaking operators will need to **GET MANUAL TRANSLATED** as needed!

DANGER

FAILING TO FOLLOW SAFETY MESSAGES AND OPERATING INSTRUCTIONS CAN CAUSE SERIOUS BODILY INJURY OR EVEN DEATH TO OPERATOR AND OTHERS IN THE AREA.

<p>1.</p> 	<p>2. No riders. No children operators.</p> 	<p>3. Use safety shoes, hard hat, safety glasses, and seat belts.</p> 	<p>4. Block up securely before working under.</p> 
---------------------------------------------------------------------------------------------	-------------------------------------------------------------------------------------------------------------------------------	---------------------------------------------------------------------------------------------------------------------------------------------------------	---------------------------------------------------------------------------------------------------------------------------------------

1. Study and understand Operator's Manuals, Safety Decals, and Instructional Decals for Truck, Auxiliary Engine and Mower to prevent misuse, abuse, and accidents. Practice using mower and boom controls before operating in a confined area or near passersby.
 • Learn how to stop truck and aux. engines suddenly in an emergency. Be alert for passersby and especially children.

2. Allow no children on or near mower or truck. Allow no riders on truck. Falling off may cause serious injury or death from being run over by truck or contact with rotating blades.

3. Operate only with truck seat belt securely fastened to prevent injury and possible death from falling off or overturn.
 • Personal Protective Equipment such as Hard Hat, Safety Glasses, Safety Shoes, & Ear Plugs are recommended.





4. Block up or support raised machine and all lifted components securely before putting hands or feet under or working underneath any lifted component to prevent crushing injury or death from sudden dropping or inadvertent operation of controls. Make certain area is clear before lowering or folding.

5. Before transporting, place mower in truck bed transport bracket and engage Transport Lock. Only transport truck on public roadways from left seat.
 • Folding and Boom Mowers have raised center of gravity. Slow down when turning and on hillsides.

6. Make certain that truck lights, warning lights, and reflectors are clearly visible. Follow local traffic codes.

7. Never operate with Cutting Head or Folding Section raised if passersby, bystanders, or traffic are within 300' to reduce possibility of injury or death from objects thrown by Blades under Guards or mower structure.

8. Before dismounting, secure implement in transport position or lower to ground.
 • Put truck in park and set parking brake, shut down mower and auxiliary engine, stop truck engine, remove key and wait until noise of rotation has ceased to prevent crushing by entanglement in rotating parts which could cause injury or death.
 • Never mount or dismount a moving vehicle. Crushing from rollover may cause serious injury or death.

<p>5. Transport safely, lock up.</p> 	<p>6. Use lights, & reflectors.</p> 	<p>7. Do not operate if persons are within 300'.</p> 	<p>8. Do not mount or dismount while moving.</p> 
--------------------------------------------------------------------------------------------------------------------------	-----------------------------------------------------------------------------------------------------------------------------	-------------------------------------------------------------------------------------------------------------------------------------------	----------------------------------------------------------------------------------------------------------------------------------------

1276

Warranty Information: Read and understand the complete Warranty Statement found in this manual. Fill out the Warranty Registration form in full and return it within 90 days. Make certain the Serial Number of the machine is recorded on the Warranty Card, and form that you retain.

FORWARD

This manual contains information about many features of the Tiger mowing and roadside maintenance equipment. Some of these include: Safety precautions, Assembly instructions, Operations, Maintenance and Parts. This manual will also assist you in the proper break-in, daily care, and troubleshooting of your new mower.

We recommend that you read carefully the entire manual before operating the unit. Also, time spent in becoming fully acquainted with its performance features, adjustments, and maintenance schedules will be repaid in a long and satisfactory life of the equipment.

Troubleshooting - Please, before you call, help us to help you!

Please look at the equipment to observe what is happening, then:

- Classify the problem
 - Hydraulic, electrical or mechanical - Read the trouble shooting section
 - Tractor or Truck chassis - Contact vehicle dealer

- If unable to correct the problem yourself, contact your local Tiger Dealer after gathering:
 - Machine model _____
 - Serial number _____
 - Dealer name _____
 - Detailed information about the problem including results of troubleshooting

Attention Owner / Operator / Dealer: It is your obligation to read, and understand, the warranty information section located at the back of this manual denoting that the purchaser understands the safety issues relating to this machine and has received and will read a copy of this manual.

If at any time, you have a service problem with your Tiger mower, Contact your local dealer for service and parts needed.

MANUFACTURED BY:

Tiger Corporation

3301 N. Louise Ave.

Sioux Falls, SD 57107

1-800-843-6849

1-605-336-7900

www.tiger-mowers.com

DISTRIBUTED BY:

1- _____ - _____ - _____

1- _____ - _____ - _____

TABLE OF CONTENTS

SAFETY SECTION_____	1
ASSEMBLY / MOUNTING SECTION_____	2
OPERATION SECTION_____	3
MAINTENANCE SECTION_____	4
PARTS SECTION_____	5
COMMON PARTS SECTION_____	6
WARRANTY INFORMATION_____	7



1012

This symbol means:

CAUTION – YOUR SAFETY IS AT RISK!

When you see this symbol, read and follow the associated instructions carefully or personal injury or damage may result.

Tiger is a registered trademark.



SAFETY SECTION

SAFETY

A safe and careful operator is the best operator. Safety is of primary importance to the manufacturer and should be to the owner/operator. Most accidents can be avoided by being aware of your equipment, your surroundings, and observing certain precautions. The first section of this manual includes a list of Safety Messages that, if followed, will help protect the operator and bystanders from injury or death. Read and understand these Safety Messages before assembling, operating or servicing this implement. This equipment should only be operated by those persons who have read the Manual, who are responsible and trained, and who know how to do so safely and responsibly.

The Safety Alert Symbol combined with a Signal Word, as seen below, is used throughout this manual and on decals which are attached to the equipment. The Safety Alert Symbol means: "ATTENTION! BECOME ALERT! YOUR SAFETY IS INVOLVED!" The Symbol and Signal Word are intended to warn the owner/operator of impending hazards and the degree of possible injury faced when operating this equipment.

Practice all usual and customary safe working precautions and above all--- remember safety is up to YOU. Only YOU can prevent serious injury or death from unsafe practices.

CAUTION!



The lowest level of Safety Message; warns of possible injury. Decals located on the Equipment with this Signal Word are Black and Yellow.

WARNING!



Serious injury or possible death! Decals are Black and Orange.

DANGER!



Imminent death/critical injury. Decals are Red and White. (SG-1)

READ, UNDERSTAND, and FOLLOW the following Safety Messages. Serious injury or death may occur unless care is taken to follow the warnings and instructions stated in the Safety Messages. Always use good common sense to avoid hazards. (SG-2)

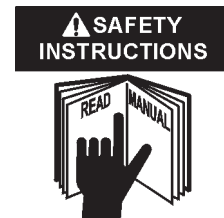

SAFETY

PELIGRO!



Si no lee Ingles, pida ayuda a alguien que si lo lea para que le traduzca las medidas de seguridad. (SG-3)

¡ LEA EL INSTRUCTIVO!



DANGER!



Never operate the Truck or Implement until you have read and completely understand this Manual, the Truck Operator's Manual, and each of the Safety Messages found in the Manual or on the Truck and Implement. Learn how to stop the truck engine suddenly in an emergency. Never allow inexperienced or untrained personnel to operate the Truck and Implement without supervision. Make sure the operator has fully read and understood the manuals prior to operation. (SG-4)

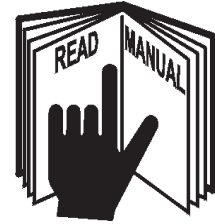

WARNING!



Always maintain the safety decals in good readable condition. If the decals are missing, damaged, or unreadable, obtain and install replacement decals immediately. (SG-5)

WARNING!



Do not modify or alter this Implement. Do not permit anyone to modify or alter this Implement, any of its components or any Implement function. (SG-8)

WARNING!



The operator of the Truck and Mower must be trained in the operation and safe use of this machine. The operator must read and completely understand the operator's manuals of the Mower, Truck and Auxiliary engine manufacturers. New operators should be trained in an open area clear of obstructions before operating on public roadways. If operation of the entire Mower unit (Truck, Auxiliary engine, and Mowing Components) is not completely understood, consult your authorized sales representative for a detailed explanation. Never allow an untrained or unqualified driver to operate the Truck and Mower. (STM-2)

CAUTION!



The Truck driver must meet the requirements and possess a Motor Vehicle License as determined by the state in which the Truck is operated if used on public roadways. Contact your local State Department of Public Safety office for special licensing requirements to drive the Truck in your area. (STM-3)

SAFETY

DANGER!



NEVER use drugs or alcohol immediately before or while operating the Truck and Implement. Drugs and alcohol will affect an operator's alertness and coordination and therefore affect the operator's ability to operate the equipment safely. Before operating the Truck or Implement, an operator on prescription or over-the-counter medication must consult a medical professional regarding any side effects of the medication that would hinder their ability to operate the Equipment safely. **NEVER** knowingly allow anyone to operate this equipment when their alertness or coordination is impaired. Serious injury or death to the operator or others could result if the operator is under the influence of drugs or alcohol. (SG-27)



WARNING!



Always wear OSHA approved Personal Protective Equipment (PPE) while operating, servicing, repairing, and/or cleaning the Truck or Mower. PPE is designed to provide bodily protection during such activities.

Personal Protective Equipment includes:

- Protective Eye Wear
- Steel Toed Safety Footwear
- Gloves
- Hearing Protection
- Close Fitted Clothing
- Hard Hat-When working around a raised Mower.
- Respirator-Depending on mowing conditions. (STM-5)

CAUTION!



Prolonged operation of the Truck and Mower may cause operator boredom and/or fatigue affecting the safe operation of the Truck and Mower. It is recommended that the operator take scheduled work breaks to help prevent these potentially impaired operating conditions. If possible, completely shut down the Truck and Mower, exit the cab and move around stretching your arms and legs. Never operate the Truck and Mower in a fatigued or bored mental state that impairs proper and safe operation.

(STM-6)

CAUTION!



PROLONGED EXPOSURE TO LOUD NOISE MAY CAUSE PERMANENT HEARING LOSS! Trucks with or without an Implement attached can often be noisy enough to cause permanent hearing loss. We recommend that you always wear hearing protection if the noise in the Operator's position exceeds 80db. Noise over 85db over an extended period of time will cause severe hearing loss. Noise over 90db adjacent to the Operator over an extended period of time will cause permanent or total hearing loss. *Note:* Hearing loss from loud noise [from trucks, chain saws, radios, and other such sources close to the ear] is cumulative over a lifetime without hope of natural recovery.

(SG-17)



SAFETY

DANGER!



Do not operate, or perform maintenance to, the Truck or Mower while wearing loose fitting clothing. Entanglement of loose clothing with the rotating elements can result in serious injury or death. Stay clear of all rotating elements at all times. (STM-8)

WARNING!



Verbal communication near the Truck and Mower is difficult and dangerous. Operating instructions and mowing directions should be made prior to starting the Truck. Unclear and misunderstood communication may lead to operator and bystander injury or death and equipment damage. If communication by the operator is necessary, completely shutdown and exit the Truck. Never allow anyone to approach the Truck and Mower while in operation. (STM-9)

DANGER!



Never allow children to play on, under, or around the Truck and Mower nor allow children to operate controls. Children can slip or fall off the Truck and be injured or killed. Children can cause the Mower components to shift or fall crushing themselves or others. (STM-10)

WARNING!



Allow passengers only in situations where their presence is involved in the Mowing operation (operator training, supervision, maintenance or inspection). Never carry passengers who's presence distracts from the safe operation or transport of the Truck and Mower. Passengers must be seated securely and belted in the cab's passenger seat. Passengers must be instructed to keep clear of steering wheel and foot pedals. Never allow any person to ride on any other location of the Truck during operation or transport. (STM-11)

DANGER!



Use extreme caution when refueling the Truck and Auxiliary Engines, fuel is highly flammable and explosive if not handled safely. Always follow these precautions to reduce the dangers involved in refueling:

1. Completely shut down the Truck and Auxiliary Engines before refueling.
2. Do Not refuel while smoking or near an open flame.
3. Do Not store the Truck and Mower with fuel in the tank in a building where fumes can reach an ignition source.
4. To prevent a fire and explosion caused by static electric discharge while filling the tank, use a plastic funnel. Avoid using a funnel that has a metal screen or filter.
5. Avoid spilling fuel. Fuel is expensive and can damage plastic and painted surfaces. Clean up spilled fuel immediately.
6. Store fuel and all oils at a site protected from moisture, dirt, and other contaminants. (STM-13)

SAFETY

WARNING!



Relieve hydraulic pressure from the hydraulic circuit prior to doing any maintenance or repair work on the unit. Place the Mower boom and head in the transport position, sitting on the ground or securely blocked up. Turn off the Truck and Auxiliary engines then manually activate the hydraulic control valves several times using the manual over-ride handle to relieve hydraulic pressure prior to performing any maintenance or repair work. (STM-12)

DANGER!



Escaping pressurized hydraulic oil generated by hydraulic pumps has the potential to inflict serious injury and possible death. Never attempt to repair a pump or hose or tighten a connection while the system is pressurized. Always shut down the Truck and Auxiliary engines and relieve hydraulic oil pressure before performing any repairs to the hydraulic system. (STM-14)

WARNING!



Always read carefully and comply fully with the manufacturers instructions when handling oil, solvents, cleansers, and any other chemical agent. (SG-22)



DANGER!



Do not operate this Equipment with hydraulic oil leaking. Oil is expensive and its presence could present a hazard. Do not check for leaks with your hand! Use a piece of heavy paper or cardboard. High-pressure oil streams from breaks in the line could penetrate the skin and cause tissue damage including gangrene. If oil does penetrate the skin, have the injury treated immediately by a physician knowledgeable and skilled in this procedure. (SG-15)



WARNING!



Battery posts, terminals and related accessories contain lead and lead compounds, chemicals known to the state of California to cause cancer and birth defects or other reproductive harm. Wash Hands after handling. (SG-31)

WARNING!



Engine Exhaust, some of its constituents, and certain vehicle components contain or emit chemicals known to the state of California to cause cancer and birth defects or other reproductive harm. (SWM-20)

DANGER!



Never run the Truck or Auxiliary engine in a closed building or without adequate ventilation. The exhaust fumes can be hazardous and deadly to your health. If it is necessary to run the Truck or Auxiliary engine in an enclosed area, remove the exhaust fumes from the area to the outdoors with an exhaust pipe extension. If you do not have an exhaust pipe extension, or if it is not possible to use one, open doors and circulate outside air into the area. (STM-15)

SAFETY

DANGER!



Start the Truck and Auxiliary engines only when seated and belted in the Truck's operator seat. Operate the Mower controls only while properly seated with the seat belt secured around you. Inadvertent movement of the Truck and/or Mower components may cause serious injury or death to the operator and passersby. Read the Truck and Auxiliary Engine operator's manuals for proper starting instructions. (STM-16)

WARNING!



Use both hands for support when getting on and off the Truck. Use hand holds and steps on the Truck for support when boarding the Truck cab, bed, or service area. Never use the Mower control levers for support when boarding the Truck. (STM-17)

WARNING!



Use available Truck hand holds and steps to exit the Truck cab. Make sure you have solid footing before stepping down. Be careful of your step and use extra caution when mud, ice, snow, or other matter has accumulated on the steps or handrails. Never rush to exit or jump off the Truck. (STM-18)

DANGER!



Do not attempt to mount the Truck while the Truck is moving or Mower is running. Never attempt to mount a runaway Truck. Serious injury or death may occur from being run over by a moving Truck. (STM-19)

DANGER!



BEFORE leaving the Truck's seat, always engage the parking brake and set the Truck's transmission in parking gear, stop the engine, remove the key, and wait for all moving parts to stop. Never dismount a Truck that is moving or while the Truck and Auxiliary engines are running. Operate the Mower controls from the Truck seat only. (STM-20)

WARNING!



Always wear a seat belt while driving the Truck during operation and transport. Serious injury or even death could result from falling out of the Truck or from being involved in a collision. (STM-21)

DANGER!



Use extreme care when climbing onto the Truck to perform repairs, maintenance, and cleaning. Use proper stands and ladders to access areas that cannot be reached from ground level. Slipping and falling off the Truck can cause serious injury or death. (STM-22)

DANGER!



BEFORE leaving the Truck seat, always engage the parking brake, stop the Auxiliary and Truck engines, remove the key, and wait for all moving parts to stop. Never dismount the Truck if it is moving or while either the Auxiliary or Truck engine is running. Opening the Truck door while the mower is operating will activate the mower brake valve stopping the mower blades. (STM-23)

WARNING!



The rotating parts of this machine continue to rotate even after the mower and auxiliary engine have been turned off. The operator should remain in his seat for 60 seconds after the brake has been set, the Truck and auxiliary engines turned off, and all evidence of rotation has ceased. (STM-24)
“Wait a minute...Save a life!”

SAFETY

WARNING!



Drive from the Truck's right side only when mowing and never while traveling above 15 MPH. For transport, the Truck must be driven from the LEFT side ONLY. If the Truck is being operated from the right side, make sure the Truck's mirrors are aligned for the right side driving position. (STM-25)

WARNING!



Do not exceed the rated operating speed for the Truck and Auxiliary engines. Excessive operating speeds can cause engine and Mower component failures resulting in possible serious injury or death. (STM-26)

WARNING!



Do not operate the Mower if excessive vibration or noise exists. Shut down the Mower and the Truck and Auxiliary engines. Inspect the Mower to determine the source of the vibration or noise. If Mower blades or components are loose, damaged, or missing, replace them immediately. Do not operate the Mower until all necessary repairs have been performed and the Mower operates smoothly. Operating the Mower with excessive vibration can result in component failure and broken objects being thrown outward at high velocities. To reduce the possibility of property damage, serious injury, or even death, never operate the Mower with missing or damaged components. (STM-27)

WARNING!



Use extreme caution when lowering or unfolding the Mower's Boom and Head. Make sure no bystanders are close by or underneath the mower when lowering. Allow ample clearance around the Mower when lowering or raising the boom. Use extreme caution around obstructions including bystanders, passersby, curbs, buildings, and other property. Use the Truck's horn to warn of danger when boom and mower head are being lowered. (STM-28)

WARNING!



Before starting a mowing operation, make sure all the warning signal lights are connected, visible and working. Routinely inspect the Truck's headlights, brake lights, backup lights, and turn signal lights for operational condition. Immediately repair non-functioning lighting. Always follow all local traffic regulations while transporting the Truck on a public road. (STM-29)

WARNING!



Always turn on all safety lights and flashers when you operate the Mower. It is recommended that you preset the beacon/strobe light switches to ON, so lights go on whenever the auxiliary engine is ON and lights go OFF whenever the auxiliary engine is turned OFF. This presetting action has the additional benefit of alerting the operator if the auxiliary engine is inadvertently left ON. (STM-30)

WARNING!



Mow only in conditions where you have clear visibility in daylight or with adequate artificial lighting. Never mow in darkness or foggy conditions where you cannot clearly see at least 100 yards in front and to the sides of the tractor and mower. Make sure that you can clearly see and identify passersby, steep slopes, ditches, drop-offs, overhead obstructions, power lines, debris and foreign objects. If you are unable to clearly see this type of items discontinue mowing. (SGM-1)

SAFETY

DANGER!



There are obvious and hidden potential hazards in the operation of this Mower. REMEMBER! This machine is often operated in heavy brush and in heavy weeds. The Blades of this Mower can throw objects if shields are not properly installed and maintained. Serious injury or even death may occur unless care is taken to insure the safety of the operator, bystanders, or passersby in the area. Do not operate this machine with anyone in the immediate area. Stop mowing if anyone is within 100 yards of mower. (SGM-2)



DANGER!



The rotating parts of this machine have been designed and tested for rugged use. However, the blades could fail upon impact with heavy, solid objects such as metal guard rails and concrete structures. Such impact could cause the broken objects to be thrown outward at very high velocities. To reduce the possibility of property damage, serious injury, or even death, never allow the cutting blades to contact such obstacles. (SGM-4)

WARNING!



Extreme care should be taken when operating near loose objects such as gravel, rocks, wire, and other debris. Inspect the area before mowing. Foreign objects should be removed from the site to prevent machine damage and/or bodily injury or even death. Any objects that cannot be removed must be clearly marked and carefully avoided by the operator. Stop mowing immediately if blades strike a foreign object. Repair all damage and make certain rotor or blade carrier is balanced before resuming mowing. (SGM-5)



WARNING!



Many varied objects, such as wire, cable, rope, or chains, can become entangled in the operating parts of the mower head. These items could then swing outside the housing at greater velocities than the blades. Such a situation is extremely hazardous and could result in serious injury or even death. Inspect the cutting area for such objects before mowing. Remove any like object from the site. Never allow the cutting blades to contact such items. (SGM-6)

WARNING!



Mow at the speed that you can safely operate and control the Truck and Mower. Safe mowing speed depends on terrain condition and grass type, density, and height of cut. Normal ground speed range is from 0 to 5 mph. Use slow mowing speeds when operating on or near steep slopes, ditches, drop-offs, overhead obstructions, power lines, or when debris and foreign objects are to be avoided. (STM-31)

WARNING!



Do not mow in the reverse direction. Check to make sure there are no persons behind the Truck and Mower before backing up. Mow only at a slow ground speed where you can safely operate and control the Truck and Mower. Never mow an area that you have not inspected and removed debris or foreign material. (STM-32)

WARNING!



Do not put hands or feet under mower decks. Blade Contact can result in serious injury or even death. Stay away until all motion has stopped and the decks are securely blocked up. (SGM-9)



SAFETY

DANGER!



Rotary and Fail Mowers are capable of throwing objects for great distances (100 yards or more) and causing serious injury or death. Follow safety messages carefully.

STOP MOWING IF PASSERSBY ARE WITHIN 100 YARDS

UNLESS:

- Front and Rear Deflectors are installed and in good working condition;
- Mower Head is running close to and parallel to the ground without exposed Blades;
- Passersby are outside of the existing thrown-object zone;
- All areas have been thoroughly inspected and all foreign material such as rocks, cans, glass and general debris has been removed

Where there are grass and weeds high enough to hide debris that could be struck by the blades, the area should be: inspected and large debris removed, mowed at an intermediate height, inspected closely with any remaining debris removed, and mowed again at desired final height. (SBM-1)

DANGER!



Use extreme caution when raising the Mower head. Stop the Blades from turning when the Mower Head is raised and passersby are within 100 yards. Raising the Mower head exposes the Cutting Blades which creates a potentially serious hazard and can cause serious injury by objects thrown from the Blades or by contact with the Blades. (SBM-2)

DANGER!



Always keep a careful lookout and use extreme care when working around overhead obstructions. Never allow the Mower head or boom within 10 feet of any power line. When working close to overhead power lines consult your electric company for a safe code of operation.

(SBM-7)

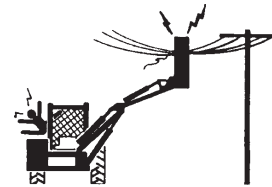

WARNING!



Inspect the entire Truck and Mower before each use. Accidents may occur or damage to the Mower may result if the Truck and Mower are not maintained in good mechanical working order.

- Check for loose bolts, worn or broken parts, pinched hydraulic hoses, and leaky or loose fittings.
- Make sure all pins are secure and safety pins equipped.
- Make sure replacement parts (blades and bolts) are the correct size and properly installed.
- Make sure all fluid levels are full and replenish as necessary.
- Make sure fuel, oil, and coolant caps are replaced and tightened.
- Check tire condition for tread wear and tire pressure at the rated PSI.
- Make sure that all safety shields and guards are attached and in good condition.
- Make sure all scheduled maintenance is up to date. (STM-33)

DANGER!



Never attempt to repair, lubricate, adjust, clean, remove obstructions or perform any other type of service to any Mower component while the Truck or Mower is in motion or while the Auxiliary and/or Truck engine is running. Completely shut down the mowing components and the Truck and Auxiliary engines and wait for all motion to come to a complete stop before servicing the Mower. (STM-34)

SAFETY

DANGER!



Never work under the Truck, the Mower, the framework, or any lifted component unless the equipment is securely supported or blocked up to prevent sudden or inadvertent falling which could cause serious injury or even death. (STM-35)

DANGER!



Replace bent or broken blade with new blades. NEVER ATTEMPT TO STRAIGHTEN OR WELD ON BLADES SINCE THIS WILL LIKELY CRACK OR OTHERWISE DAMAGE THE BLADE WITH SUBSEQUENT FAILURE AND POSSIBLE SERIOUS INJURY FROM THROWN BLADES. (SGM-10)

WARNING!



Never leave the Truck and Mower unattended while the Mower head is in the raised position. The mower could fall causing serious injury to anyone who might inadvertently be under the mower. (STM-36)

DANGER!



Always disconnect the wire leads from the mower valve solenoid before performing service on the Tractor or Mower. Use caution when working on the Tractor or Mower. Tractor engine must be stopped before working on Mower or Tractor. The Mower Blades could inadvertently be turned on without warning and cause immediate dismemberment, injury or death. (SBM-12)

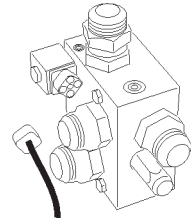

WARNING!



Periodically inspect all moving parts for wear and replace when necessary with authorized service parts. Look for loose fasteners, worn or broken parts, and leaky or loose fittings. Make sure all pins have cotter pins and washers. Serious injury may occur from not maintaining this machine in good working order. (SG-21)

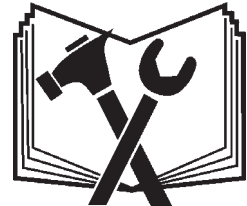

DANGER!



NEVER work on or near any engine component that has generated heat until it has cooled down. NEVER check or replenish the fluid levels of the Truck and Auxiliary engine coolant or hydraulic circuit oil levels until sufficient time has passed (up to 2 hours) to allow the system to cool down. Contact with a hot engine component or operating fluid may result in serious injury from burns, scalding and possible death. (STM-39)

WARNING!



Follow these guidelines to reduce the risk of equipment and grass fires while operating, servicing, and repairing the Mower and Truck:

- Equip the Truck with a fire extinguisher in an accessible location.
- The Truck is equipped with an under frame exhaust. Do Not drive the truck over dry grass or combustible material.
- Do Not smoke or have an open flame near the Mower and Truck.
- Do Not drive into burning debris or freshly burnt areas.
- Never allow clippings or debris to collect near auxiliary engine or Mower head. Periodically shut down the Truck and Mower and clean clippings and collected debris from the Truck and Mower deck areas. (STM-40)

SAFETY

DANGER!



All Safety Shields, Guards, deflectors, retractable door shields, and other Protective Safety devices must be used and maintained in good working condition. All safety devices should be inspected carefully at least daily for missing or broken components. **NEVER REMOVE PROTECTIVE SHIELDS AND GUARDS! NEVER MODIFY OR CUT PROTECTIVE SHIELDS OR GUARDS!** When shields or guards are removed to access areas for maintenance, they must be replaced and be in good condition before operating. Missing, broken, or worn shields, guards, and other protective devices must be replaced at once and prior to operation to reduce the possibility of injury or death from thrown objects, entanglement, or contact. (STM-41)

WARNING!



When transporting the Truck between mowing locations, follow all local traffic laws and regulations. Disengage all Mower controls and secure Mower head in transport position on the Truck bed. Disengage all warning signals prior to entering vehicle traffic. (STM-42)

WARNING!



Make sure there is no bystander, animal or obstruction such as a vehicle, building, or street sign are behind the Truck when backing up. The design of the Mower impairs operator rear vision when backing. Use extreme caution to ensure that the Truck is not backed into the path of pedestrian or vehicle traffic. Serious injury or death and property damage could result from running into, being crushed by, or run over by the Truck. (STM-43)

WARNING!



Transport the Truck and Mower only at safe speeds. Serious accidents and injuries can result from driving this Truck at unsafe speeds. Become familiar with the driving characteristics of the Truck and how it handles before operating or transporting on streets and highways. Make sure the Truck's steering, brakes, tires, and wheels are in good condition and operate properly.

Before transporting the Truck and Mower determine the safe transport speeds for you and the machine. Make sure you abide by the following rules:

1. Test the Truck and Mower at a slow speed and increase the speed slowly. Apply the brakes smoothly to determine the stopping characteristics of the Truck equipped with the Mower. As you increase the speed of the Truck, the stopping distance increases. Determine the maximum safe transport speed. When driving down a hill or on wet, rain slick, snow covered, or icy roads, the braking distance increases: use extreme care and reduce your speed. Do not operate the Truck with weak or faulty brakes.
2. Obey all traffic laws and regulations. Never exceed the posted speed limit. Never exceed warning speed limits for curves and down hill operation.
3. The Truck and Mower have a high center of gravity. Use extreme caution when transporting at highway speeds. Slow down for sharp corners and rough or uneven surfaces to avoid tipping or turning the Truck over.
4. Only transport the Truck at the speeds determined as safe and which allow for proper control of the machine while driving and stopping during an emergency.
5. When operating in traffic, use the Truck's directional indicator or signal lights to indicate your movement. Always use the Truck's flashing signal lights and other equipped warning features to alert motorist of your presence and slow moving speed while mowing. Be Aware of Traffic Around You and Watch Out for the Other Guy. (STM-44)

SAFETY

DANGER!



Use extreme caution when operating the Truck and Mower near traffic. To alert motorists of the Mower's presence, the Truck is equipped with warning signals and flashing lights. Optional electrical lights, flashers and a warning barlight, strobe, or beacon may be positioned on top of the cab. Use all equipped warning signals to alert motorists and pedestrians of the Truck's presence and relatively slow speed. Serious injury or death and property damage may occur if a vehicle collides with the Truck. (STM-45)

DANGER!



When transporting Boom Mower on a truck or trailer, the height or width may exceed legal limits when the boom is in the transport position. Contact with side or overhead structures or power lines can cause property damage or serious injury or death. If necessary lower boom to reduce height and/or remove mowing head to reduce width to the legal limits. (SBM-8)

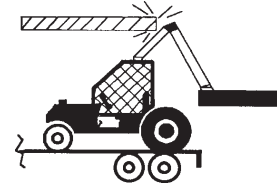

WARNING!



DO NOT weld or repair rotating mower components. Welds and other repairs may cause severe vibration and/or component failure resulting in parts being thrown from the mower causing serious bodily injury. See your Authorized Dealer for proper repairs. (SGM-13)

WARNING!



The Joystick Master Control Switch must be OFF to prevent accidental movement of the boom and cutting head whenever the mower is not being operated. (SBM-16)

WARNING!



In the event of mower head or boom control failure, stop mowing and shut down the auxiliary engine. DO NOT resume mowing again until control functions are properly repaired. Only transport the truck with the mower boom and head properly stored on the bed in the transport position. DO NOT transport on public roads with boom or head extended from the truck. (STM-46)

WARNING!



If the Auxiliary Engine controls stop functioning, immediately stop mowing and shut down the mower and auxiliary engine. If the engine cannot be shutdown by turning the ignition key to OFF, disconnect the negative battery cable to kill the engine. DO NOT transport the truck with the auxiliary engine running. (STM-47)

CAUTION!



Check truck tire pressure daily. Maintain tire pressure at tire manufacturer's specifications. Improper tire inflation can result in loss of steering control and premature tire failure. (STM-48)

CAUTION!



Remove the positive (+) battery cable from the battery before performing any electrical maintenance or repair to the truck, auxiliary engine or mower. An inadvertent electrical short or spark could cause bodily injury, electric component damage and/or ignite a fire. (STM-49)

SAFETY

WARNING!



Secure the mower boom and head in the transport position as outlined below before traveling on public roads or traveling faster than 15 M.P.H..

- 1) Turn Mower Control Switch OFF and wait until all rotation has come to a complete stop.
 - 2) Place mower on truck bed stowed in transport bracket.
 - 3) Turn Joystick Master Switch OFF.
 - 4) Turn Travel Lock Switch ON.
 - 5) Only transport the truck on public roads from left side driver's position.
- Failure to follow these steps could result in bodily injury or property damage. (STM-50)

DANGER!



Maintain Truck stability when extending the boom and mower head to prevent tip-over which could cause serious injury or even death.

- 1) DO NOT extend boom if Truck is on a side slope greater than 10% (5 degree slope).
- 2) DO NOT drive the truck off the road shoulder or into loose or wet soils.
- 3) When the mower boom is extended, avoid driving the truck into potholes or depressions that could cause the Truck to tip violently. (STM-51)

Tiger mowers use balanced and matched system components for blade carriers, blades, cutter-shafts, knives, knife hangers, rollers, drive-train components and bearings. These parts are made and tested to Tiger specifications. Non-genuine "will fit" parts do not consistently meet these specifications. The use of "will fit" parts may reduce mower performance, void mower warranties and present a safety hazard. Use genuine Tiger mower parts for economy and safety.

SEE YOUR



DEALER

In addition to the design and configuration of this Truck and Implement, including Safety Signs and Safety Equipment, hazard control and accident prevention are dependent upon the awareness, concern, prudence, and proper training of personnel involved in the operation, transport, maintenance, and storage of the machine. Refer also to Safety Messages and operation instruction in each of the appropriate sections of the Truck and Equipment Manuals. Pay close attention to the Safety Signs affixed to the Truck and Equipment. (STM-52)

SAFETY

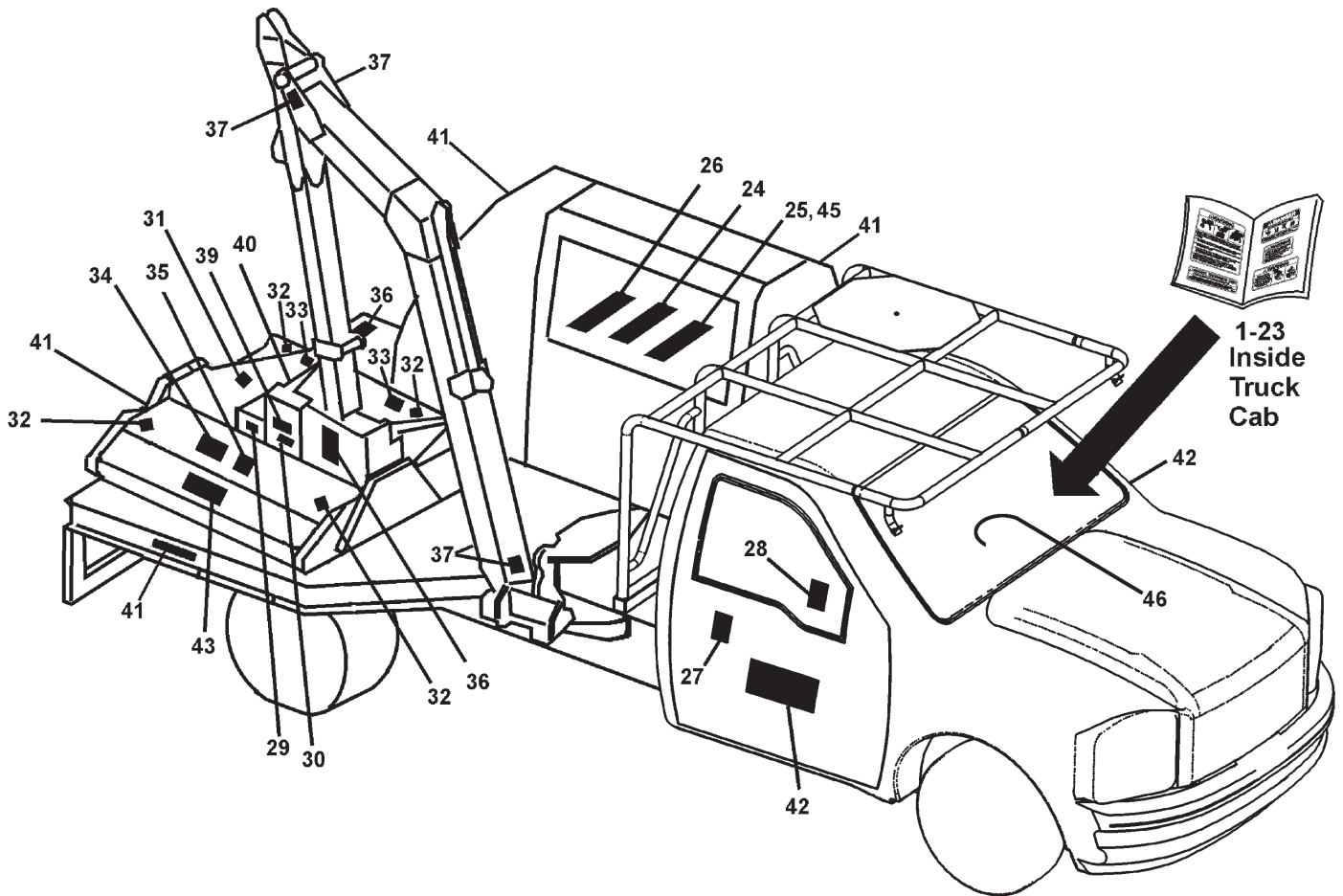

ITEM	QTY.	PART N O.	DESCRIPTION	LOCATION
1-23,47	1	34745	TrucKat® Safety Information Folder	Inside Truck Cab
24	1	02966307	Use Universal Hyd. Oil	Hydraulic Tank
25	2	6T3233	Do Not Oper. w/Valve Closed	Hydraulic Tank-Both Sides
26	1	02971123	Pressurized Tank	Hydraulic Tank
27	1	22645	Polycarbonate Window	Truck Door Safety Shield
28	1	33302	Joystick Operation	Truck Window
29	1	6T3221	Lubricate Spindle	Mower Deck-Rotary
30	1	22839	Do Not Use Auto. Grease Gun	Mower Deck-Rotary Rear
31	1	42350	Blade Rotation Direction	Mower Deck-Rotary Rear
32	4	6T3217	Keep Hand and Feet Clear	Mower Deck-Rotary Front, Rear
33	2	6T3224	Discharge Opening	Mower Deck-Rotary Front
34	1	33224	Safety Shield Operation	Mower Deck-Rotary Front
35	1	TB1011	Do Not Remove Shield	Mower Deck-Rotary Front
36	2	00769737	Keep Away-Rotating Blades	Mower Deck-Rotary Front, Rear
37	6	02962764	Pinch Points	All Boom Sections
38	1	03200285	Watch Your Step	Truck Bed Rear
39	1	42400	Reflector-Amber	Mower Deck Rear
40	1	42399	Reflector-Red	Mower Deck Front
41	3	35200	TrucKat® Logo-Paw 13.5" x 3"	Truck Bed Both Sides Rear
42	2	35201	TrucKat® Logo-Tiger	Truck Door Both Sides
43	2	31522	Tiger Mowers	Mower Deck Front, Rear
45	1	34852	Lubrication specification decal	Hydraulic Tank
46	1	06550025	Decal, Height, Trans, TrucKat	Inside Cab on Dash Right Side
47	3	06550034	Decal, Danger Crush, TrucKat	Both Sides & Rear of Truck Bed

SAFETY

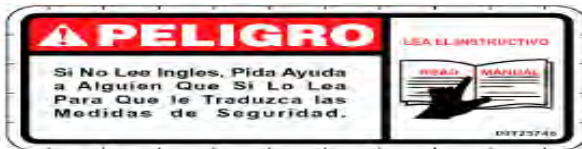

1 - SAFETY INFORMATION FOLDER



2 - SAFETY INFORMATION FOLDER



3 - SAFETY INFORMATION FOLDER

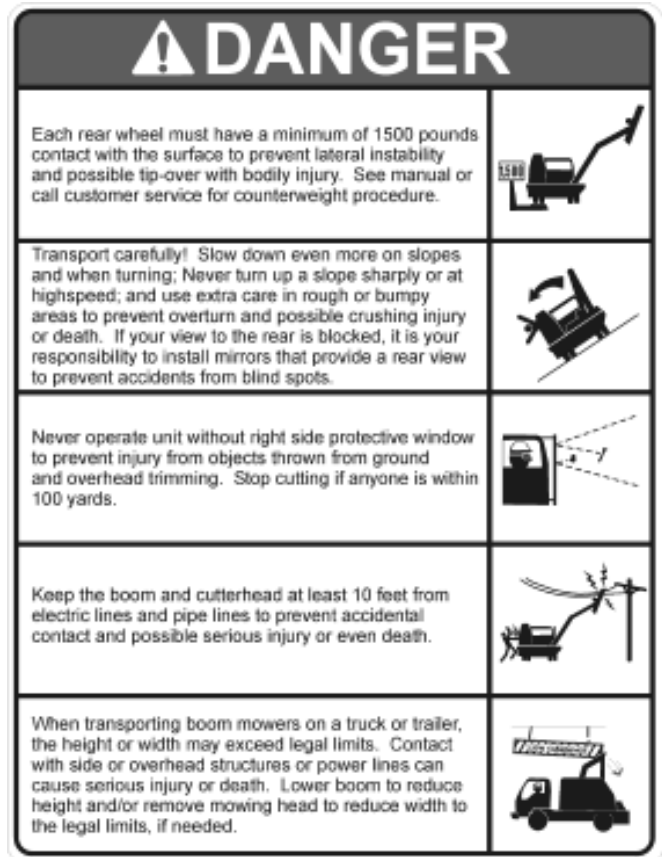

4 - SAFETY INFORMATION FOLDER

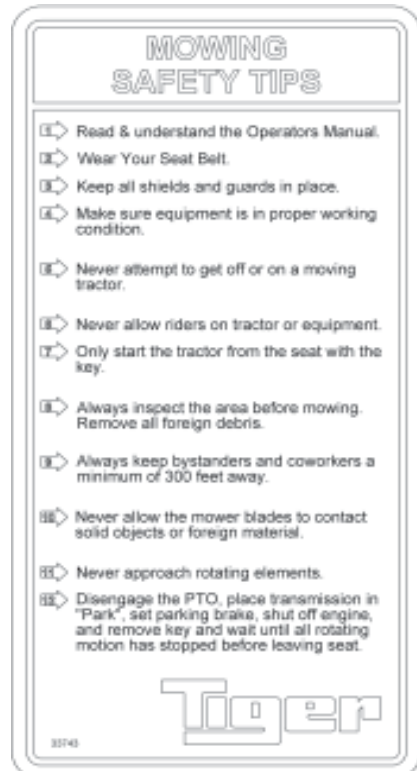

5 - SAFETY INFORMATION FOLDER

SAFETY



1295

6 - SAFETY INFORMATION FOLDER



10 - SAFETY INFORMATION FOLDER



1298

7 - SAFETY INFORMATION FOLDER



001473

11 - SAFETY INFORMATION FOLDER

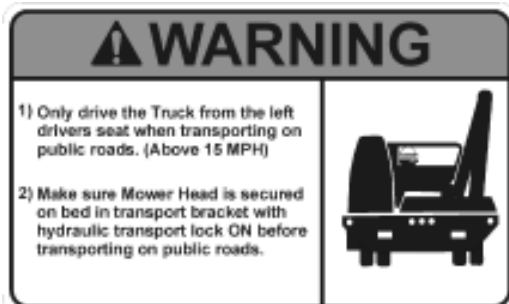

1296

8 - SAFETY INFORMATION FOLDER



6T3224

12 - SAFETY INFORMATION FOLDER



1297

9 - SAFETY INFORMATION FOLDER

13 - SAFETY INFORMATION FOLDER

SAFETY



14 - SAFETY INFORMATION FOLDER



15 - SAFETY INFORMATION FOLDER

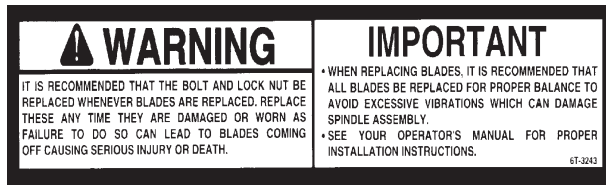

16 - SAFETY INFORMATION FOLDER

18 - SAFETY INFORMATION FOLDER

19 - SAFETY INFORMATION FOLDER



20 - SAFETY INFORMATION FOLDER



17 - SAFETY INFORMATION FOLDER

21 - SAFETY INFORMATION FOLDER

SAFETY

⚠ WARNING

Disconnect the hydraulic solenoid before performing service work on truck or mower to prevent inadvertent mower head start up.

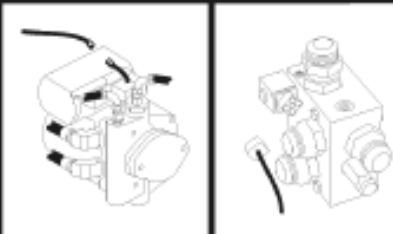

1293

22 - SAFETY INFORMATION FOLDER

⚠ CAUTION

For your safety and to guarantee optimum product reliability, always use genuine TIGER replacement parts. The use of inferior "will-fit" parts will void warranty of your TIGER implement and may cause premature or catastrophic failure which can result in serious injury or death. If you have any questions concerning the repair parts you are using, contact TIGER, 3301 N. LOUISE AVE., SIOUX FALLS, SD 57107

32709

23 - SAFETY INFORMATION FOLDER

ATTENTION

SERVICE HYDRAULIC SYSTEM WITH UNIVERSAL TRACTOR HYDRAULIC OIL.

32708

24 - 02966307

⚠ CAUTION

DO NOT START OR RUN WITH VALVES CLOSED. (SERIOUS DAMAGE WILL OCCUR)

6T-3233

25 - 6T3233

POLYCARBONATE WINDOW

REFER TO OPERATORS MANUAL FOR CLEANING INSTRUCTIONS

27 - 22645

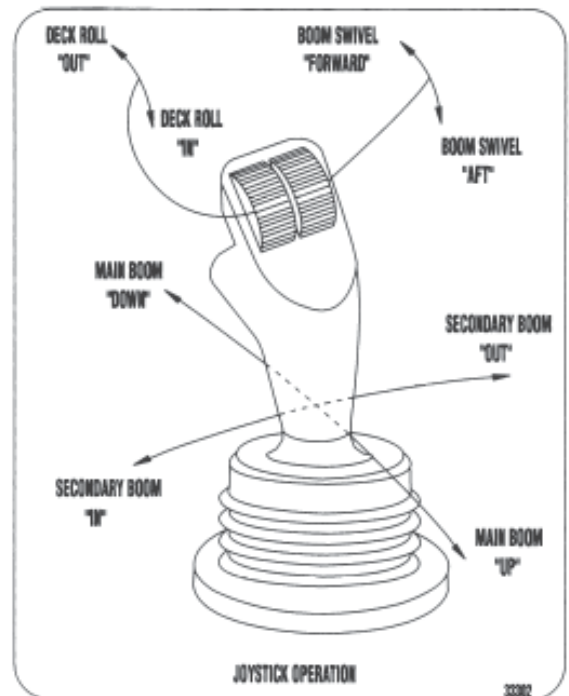

28 - 33302

⚠ CAUTION

LUBRICATE SPINDLE DAILY OR EVERY 10 HOURS OF USE. **WITH MOWER AND TRACTOR OFF**, INJECT TWO PUMPS OF TIGER SPINDLE LUBRICANT INTO SPINDLE BEFORE USING.

NOTE: SEE OPERATORS MANUAL FOR SUBSTITUTE LUBRICANT AND MORE DETAILED INSTRUCTIONS.

6T3221

29 - 6T3221

26 - 02971123

SAFETY

DO NOT LUBRICATE WITH AUTOMATIC GREASE GUN. GREASE WITH HAND GREASE GUN ONLY.

P/N22839

30 - 22839



31 - 42350



32 - 6T3217



33 - 6T3224

34 - 33224



35 - TB1011

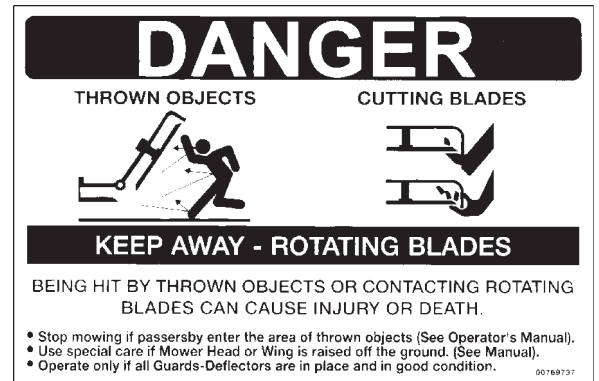

36 - 00769737



37 - 02962764

SAFETY



38 - 03200285



42 - 35201



39 - 42400



43 - 31522



40 - 42399



44 - 35203



41 - 35200

SAFETY



Tiger Corporation

800-843-6849

www.tiger-mowers.com

Description	Application	General Specification	Recommended Lubricant
Tractor Hydraulics	Reservoir	JD-20C	Mobilfluid® 424
Mower Hydraulics Cold Temperatures 0°F Start-up Normal Temperatures 10°F Start-up Normal Temperatures 15°F Start-up High Operating Temperatures Above 90°F Ambient	Reservoir	ISO 46 Anti-Wear/ Low Temp JD-20C ISO 46 Anti-Wear ISO 100 Anti-Wear	Mobil DTE® 15M Mobilfluid® 424 Mobil DTE® 25 Mobil DTE® 18M
Flail Rear Gearbox	Reservoir	PAO Synthetic Extreme Pressure Gear Lube	Mobilube SHC® 75W-90, Mobil 1 Synthetic Gear Lubricant
Cutter Shaft and Ground Roller Shaft (Flail)	Grease Gun	Lithium Complex, NLGI 2 ISO 320	Mobilgrease® CM-S
Drive Shaft Coupler (Rotary and Flail)	Grease Gun	Lithium Complex, NLGI 2 ISO 320	Mobilgrease® CM-S
Boom Swivel, Boom Cylinder Pivots (Rotary and Flail Boom Type)	Grease Gun	Lithium Complex, NLGI 2 ISO 320	Mobilgrease® CM-S
Deck Boom Pivot & Deck Stop Adjustment (Rotary and Flail)	Grease Gun	Lithium Complex, NLGI 2 ISO 320	Mobilgrease® CM-S
Deck Spindle (Rotary)	Grease Gun	Tiger Spindle Lubricant	Mobilith SHC 220

For Mobil product information, availability, or technical information, call 1-800-862-4525.

Tiger PN 34852

45 - 34852

Auxilliary Engine fuel source will be depleted at approximately 1/4 tank. This ensures enough fuel to return home.

46 - 06550009

SAFETY

FEDERAL LAWS AND REGULATIONS

This section is intended to explain in broad terms the concept and effect of federal laws and regulations concerning employer and employee equipment operators. This section is not intended as a legal interpretation of the law and should not be considered as such.

Employer-Employee Operator Regulations

U.S. Public Law 91-596 (The Williams-Steiger Occupational and Health Act of 1970) OSHA

This Act Seeks:

“...to assure so far as possible every working man and woman in the nation safe and healthful working conditions and to preserve our human resources...”

DUTIES

Sec. 5 (a) Each employer-

(1) shall furnish to each of his employees employment and a place of employment which are free from recognized hazards that are causing or are likely to cause death or serious physical harm to his employees;

(2) shall comply with occupational safety and health standards promulgated under this Act.

(b) Each employee shall comply with occupational safety and health standards and all rules, regulations and orders issued pursuant to this Act which are applicable to his own actions and conduct.

OSHA Regulations

OSHA regulations state in part: “At the time of initial assignment and at least annually thereafter, the employer shall instruct every employee in the safe operation and servicing of all equipment with which the employee is, or will be involved.”

Employer Responsibilities:

To ensure employee safety during Truck and Implement operation, it is the employer’s responsibility to:

1. Train the employee in the proper and safe operation of the Truck and Implement.
2. Require that the employee read and fully understand the Truck and Implement Operator’s manual.
3. Permit only qualified and properly trained employees to operate the Truck and Implement.
4. Maintain the Truck and Implement in a safe operational condition and maintain all shields and guards on the equipment.
5. Ensure the Truck is equipped with functional seat belts and require that the employee operator securely fasten the safety belts at all times.
6. Forbid the employee operator to carry additional riders on the Truck.
7. Provide the required tools to maintain the Truck and Implement in a good safe working condition and provide the necessary support devices to secure the equipment safely while performing repairs and service.

Child Labor Under 16 Years of Age

Some regulations specify that no one under the age of 16 may operate power machinery. It is your responsibility to know what these regulations are in your own area or situation. (Refer to U.S. Dept. of Labor, Employment Standard Administration, Wage & Home Division, Child Labor Bulletin #102.)

SAFETY

ASSEMBLY SECTION

ASSEMBLY

Before attempting to mount your Tiger mower, it is important to read and understand all of the Safety Messages in the Safety section of this manual.

Check complete shipment list against the packing list to make sure there are no shortages. Make certain the truck model is the appropriate one for the mower received!



Always use a floor jack, hoist or fork lift to lift and raise heavy parts.

Read and understand the entire assembly section instructions before attempting to mount your Tiger mower. Refer to the parts section of this manual for detailed illustrations to locate all parts. (ASM-TRK-0001)

WEATHER-PACK/METRI-PACK ASSEMBLY

These instructions apply to both Weather-Pack and Metri-pack connectors.

NOTE: Use the specific tool for the type of connector you are assembling.

(ASM-C-0009)

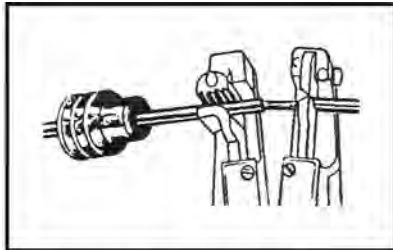

1. Apply seal to cable, before stripping insulation.



2. Align seal with cable insulation.

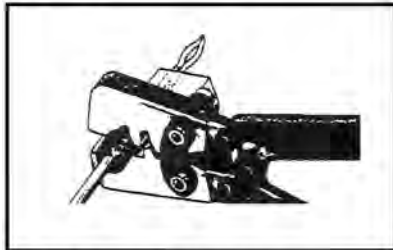

3. Put terminal in crimping tool, then

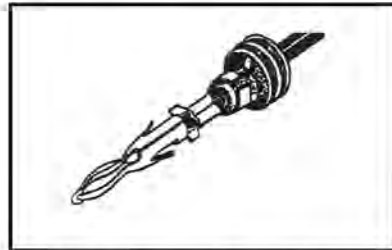

4. Crimp and visually inspect for a good



ASSEMBLY

ELECTRONIC VALVE CONVERSION

Before installing the Electronic Valve it must first be converted to an "OPEN CENTER" valve. The illustration below shows the location where this is done. The Inlet/Outlet section is labelled in three locations. The part to be converted is located closest to the "LS" or Load Sense area.

Remove A, B then C. Insert new plug (Tiger P/N 33943) and then reinstall A.

(ASM-TRK-0002)

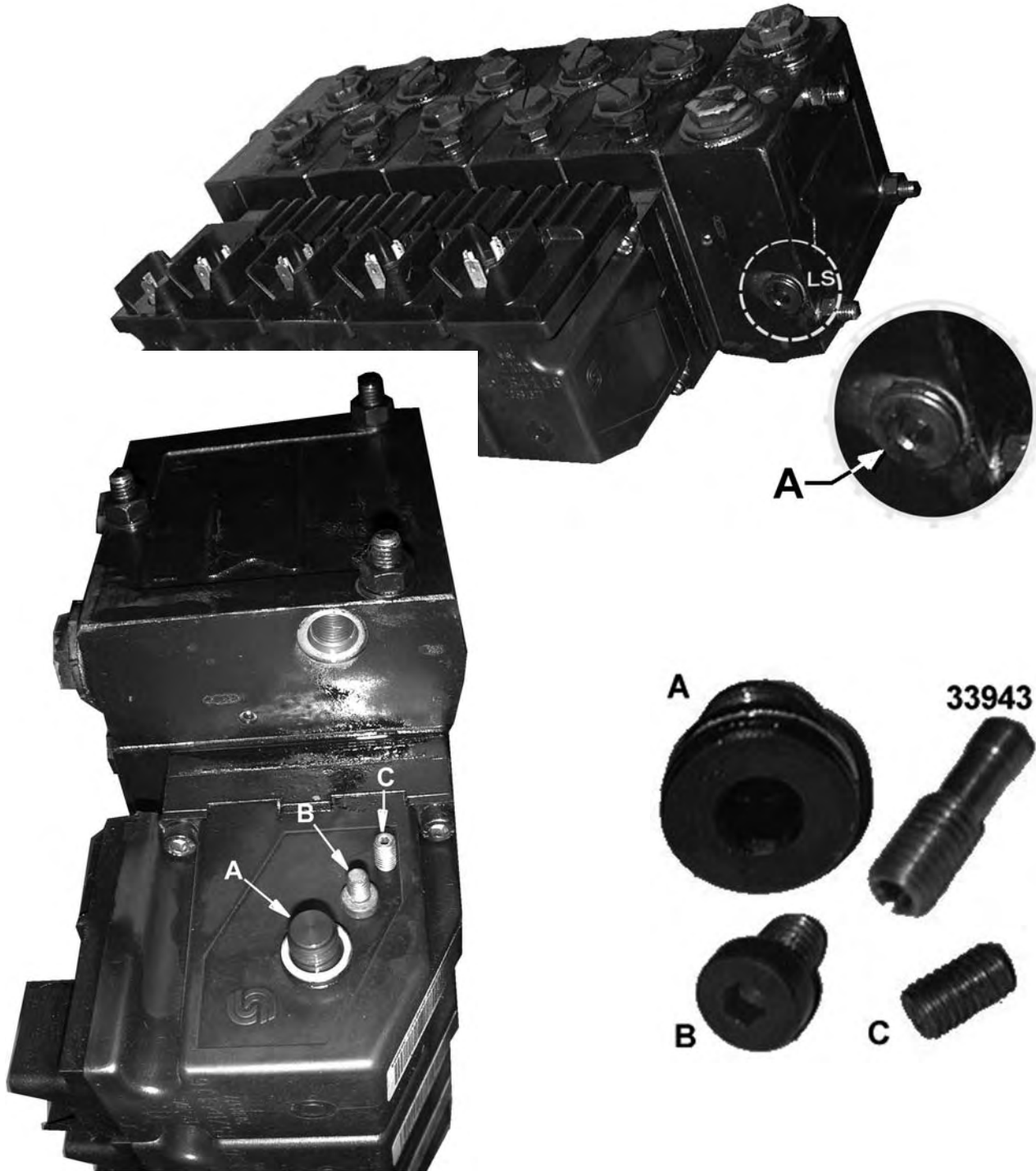

ASSEMBLY

WEIGHT MOUNTING

For all mowers using a boom, counter weight will be required for the left rear side of the truck bed. It will be necessary to mount all the plate weights in the left rear side of the truck bed frame per diagram in the Parts Section. Installation is most easily done with a small fork lift. (ASM-TRK-0003)

FACTORY SETTINGS

All TruckKat® Mowers are factory assembled and adjusted for maximum performance. Any more adjustment is not required. If further joystick setting adjustment is desired, carefully follow the instructions stated on the following pages. (ASM-TRK-0004)

METRI-PACK ASSEMBLY

(ASM-TRK-0005)

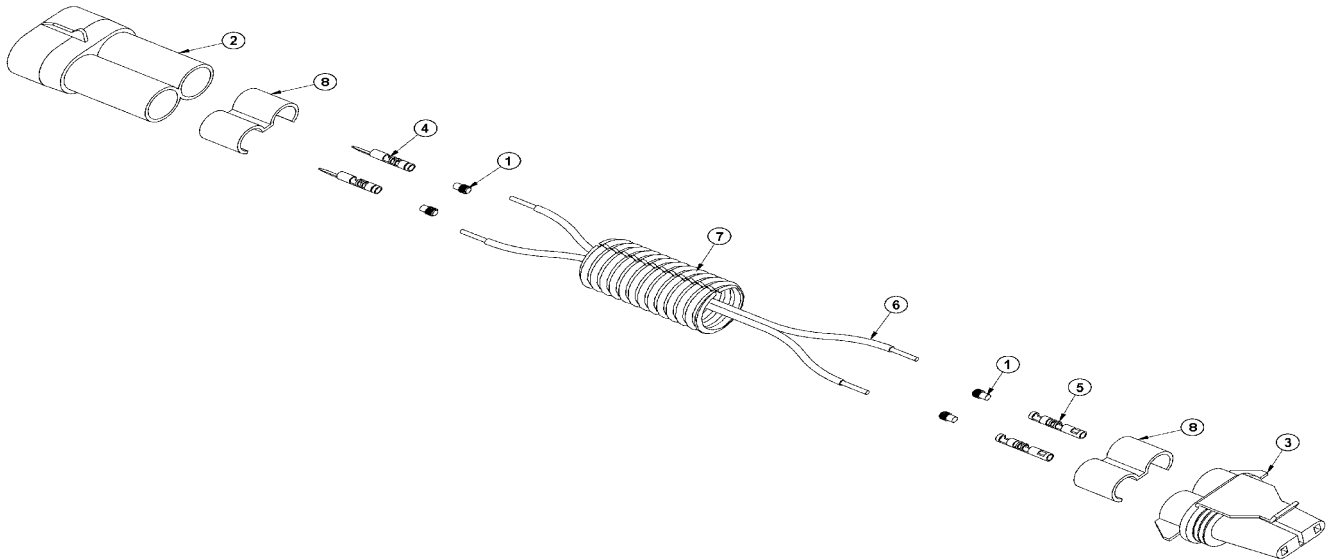

ITEM PART NO. QTY. DESCRIPTION

- 1 065100514SEAL,16-18GA,METRIPACK 150
- 2 065100521CONN.,BODY,MALE
- 3 065100531CONN.,BODY,FEMALE
- 4 065100542TERMINAL,MALE
- 5 065100552TERMINAL,FEMALE
- 6 0651006515TPAWIRE,16GA,2LINE,WHITE/BLK
- 7 PT3905E15WIRE WRAP,1/2"
- 8 065100562TPA,METRIPACK 150

Table 1: METRI-PACK CONNECTOR ASSY

ITEM	PART NO.	QTY.	DESCRIPTION
1	06510051	4	SEAL, 16-18GA
2	06510052	1	CONN., BODY, MALE



ASSEMBLY

Table 1: METRI-PACK CONNECTOR ASSY

ITEM	PART NO.	QTY.	DESCRIPTION
3	06510053	1	CONN., BODY, FEMALE
4	06510054	2	TERMINAL, MALE
5	06510055	2	TERMINAL, FEMALE
6	06510065	-	WIRE, 16GA,2LINE
7	PT3905E	-	WIRE WRAP, 1/2"
8	06510056	2	TPA, METRI-PACK 150

LEFT-HAND BATTERY CONNECTIONS

- 1 Remove Truck battery terminals from battery on Left side of truck cab.
- 2 Route the Tiger battery terminals through down through the engine compartment, underneath the truck cab, towards the rear.
- 3 Connect Truck terminals to the Tiger terminal wires.
- 4 Connect the wire running from the Cummins console to the positive Truck terminal. This wire has a 30AMP in-line fuse and should be routed through the firewall.
- 5 Install Tiger battery terminals to battery after all wiring is complete. *(ASM-TRK-0007)*

MAIN BOOM INSTALLATION

Install the boom swivel into the main frame as shown in the parts section using a hoist. Line up holes in swivel and main frame for large swivel pin and insert pin. Secure with hardware as shown.

Attach the inner end of the main boom to the swivel bracket with the cylinder anchors positioned upward, and at a right angle to the tractor. Secure it with the horizontal hinge pin. Secure the hinge pin in the boss with capscrews, etc. (see Parts Section).

Attach the butt end of the main boom cylinder to the swivel with the cylinder pin and roll pins shown in the Parts Section.

Install the travel lock on the butt end of the main boom cylinder. This should be facing the rod end of the cylinder after installation.

Install the fittings and hoses to the main boom cylinder per Parts Section.

GREASE HINGE PIN ZERKS ON BOOM AFTER ASSEMBLY, ONCE UNDER LOAD WITH BOOM ELEVATED AND AGAIN AT REST WITH BOOM SUPPORTED *(ASM-TRK-0012)*

FILLING HYDRAULIC RESERVOIR

Refer to the maintenance section for filling specifications and hydraulic oil requirements.

NOTE: Starting or running your Tiger mower before filling reservoir will cause serious damage to hydraulic pump.

(ASM-C-0004hydro resrv)



ASSEMBLY

TRUCK TAIL LIGHT WIRING



The right and left hand Tiger wire harnesses will draw power from the same wires used to power the tail lights. Remove the tail lights from the Ford truck chassis and set aside, these will be installed into the Tiger flatbed frame later.

Identify the right and left taillight connectors and mark them as "RH" & "LH". Make sure there is at least 6" of wire remaining and cut the wires to the grey connectors. Set aside, these will be used on the Tiger wire harnesses as described below.

You will need to install a Weatherpak connector on the remaining wire ends protruding from the Ford truck chassis. These will connect to the Tiger wire harnesses 06512002 and 06512003. Using the table below, match the weatherpak pins with the Ford wire colors. (ASM-TRK-0006)

FORD WIRES WEATHERPAK LEFT HANDTOWER CONN.

YELLOW / GREENPIN A - MARKER LIGHTS
BLACK / WHITEPIN B - GROUND
BLUE / WHITEPIN C - REVERSE /
BACKUP ALARM
GREY / PURPLEPIN D - LEFT TURN /
BRAKE

FORD WIRES WEATHERPAK RIGHT HANDTOWER CONN.

YELLOW / GREENPIN A - MARKER LIGHTS
BLACK / WHITEPIN B - GROUND
BLUE / WHITEPIN C - REVERSE /
BACKUP ALARM
PURPLE / ORANGEPIN D - RIGHT TURN /
BRAKE

Using the table below, attach the Ford left grey connector to harness 06512002 and the Ford right grey connector to harness 06512003 using the (4) bare wires on the harnesses and grey connectors.

FORD CONN. 06512002 LEFT HAND

YELLOW / GREENBROWN
BLACK / WHITEBLACK
BLUE / WHITEBLACK / PURPLE
GREY / PURPLEORANGE / GREEN

FORD CONN. 06512003 RIGHT HAND

YELLOW / GREENBROWN
BLACK / WHITEBLACK
BLUE / WHITEBLACK / PURPLE
PURPLE / ORANGEORANGE / GREEN

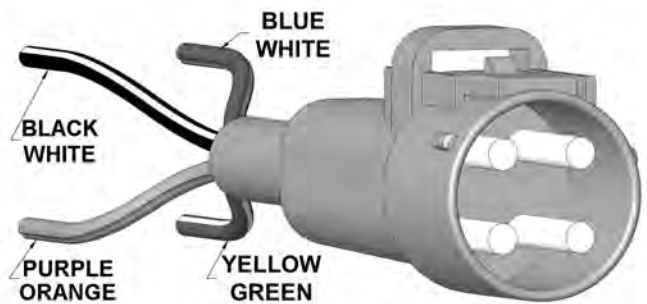
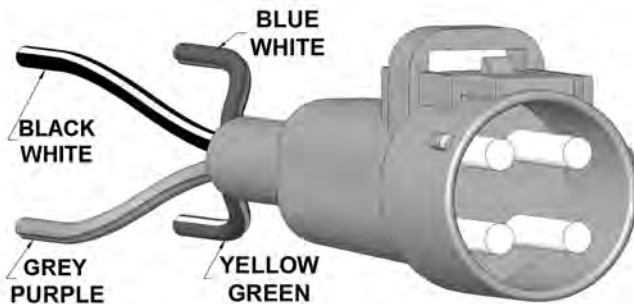

ASSEMBLY

CENTER FUSE BANK

1. The fuse bank should be located behind the switch box approximately as shown below.
2. Attach the fuse bank to the truck firewall using three #10 X 1-1/2" self-tapping capscrews (P/N 06530203).
3. Connect wires shown below from the Wire Harness.
4. Connect the red wire from the "Upfitter 1" truck switch.
5. Connect the white wires from the air compressor.
6. Install the fuses. (ASM-TRK-0008)

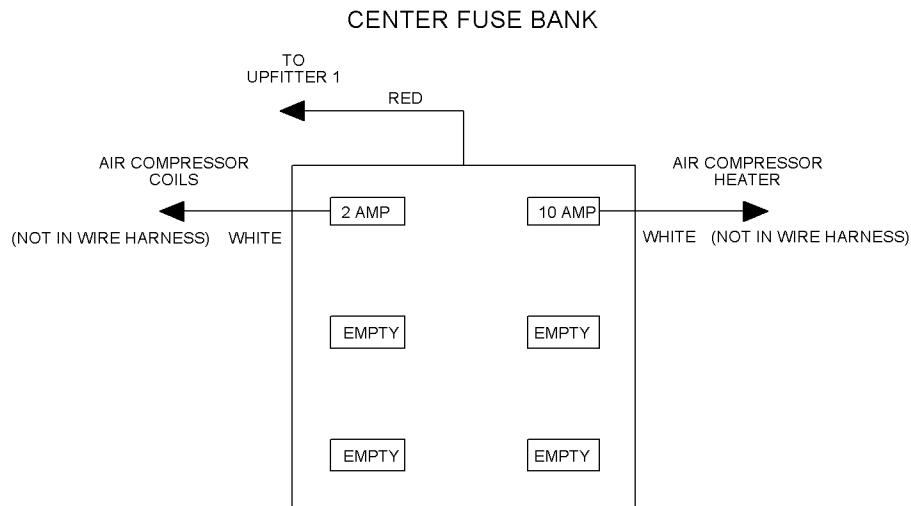

SWITCH BOX



CENTER FUSE BANK



ASSEMBLY

UREA FILLER NECK ASSEMBLY

Use the template on the next page to drill two new $\varnothing 5/16$ " holes into the Urea Filler Mount locating the pattern on the center hole and the bottom left hole. Next, insert the Urea Filler Mount into the cut-out in the rail of the truck bed and use the six #10 x 3/4" self-tapping screws to attach the Mount to the truck bed. Insert the Filler Neck into the Filler Mount and attach using the three #6-32 x 3/4" machine screws and nut-clips. (ASM-TRK-0009)

#10 x 3/4" SCREWS
P/N 06537036 (6x)

RIGHT SIDE
OF TRUCK



#6 x 3/4" SCREWS
P/N 06530301 (3x)

VIEW FROM
BACK SIDE



ASSEMBLY

UREA FILLER NECK TEMPLATE

(ASM-TRK-0010)

EXISTING
HOLE

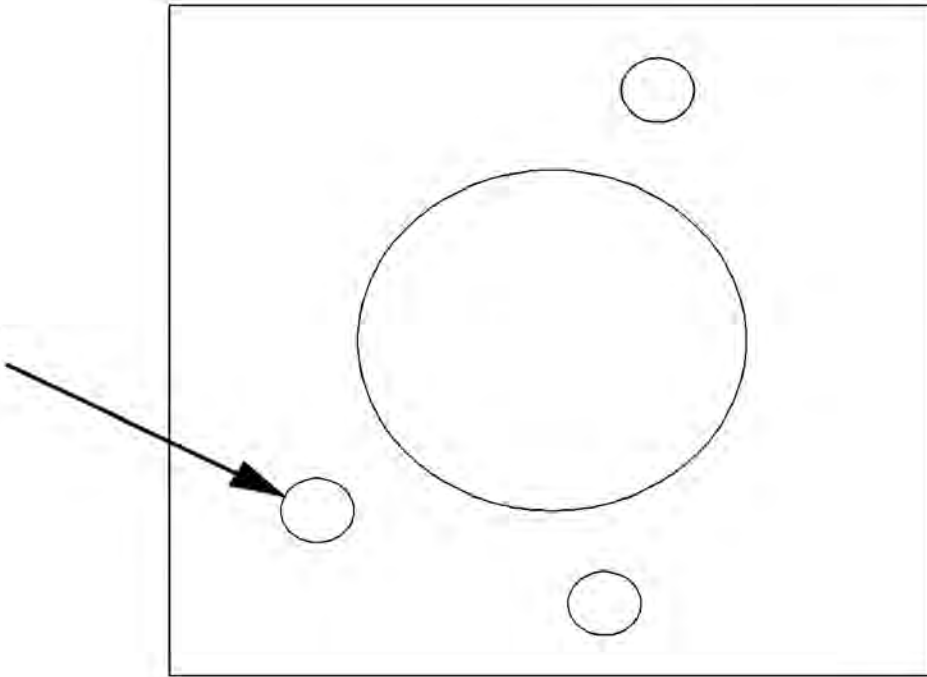

ASSEMBLY



ASSEMBLY

TRUCKAT[®] HYDRAULIC DIAGRAM

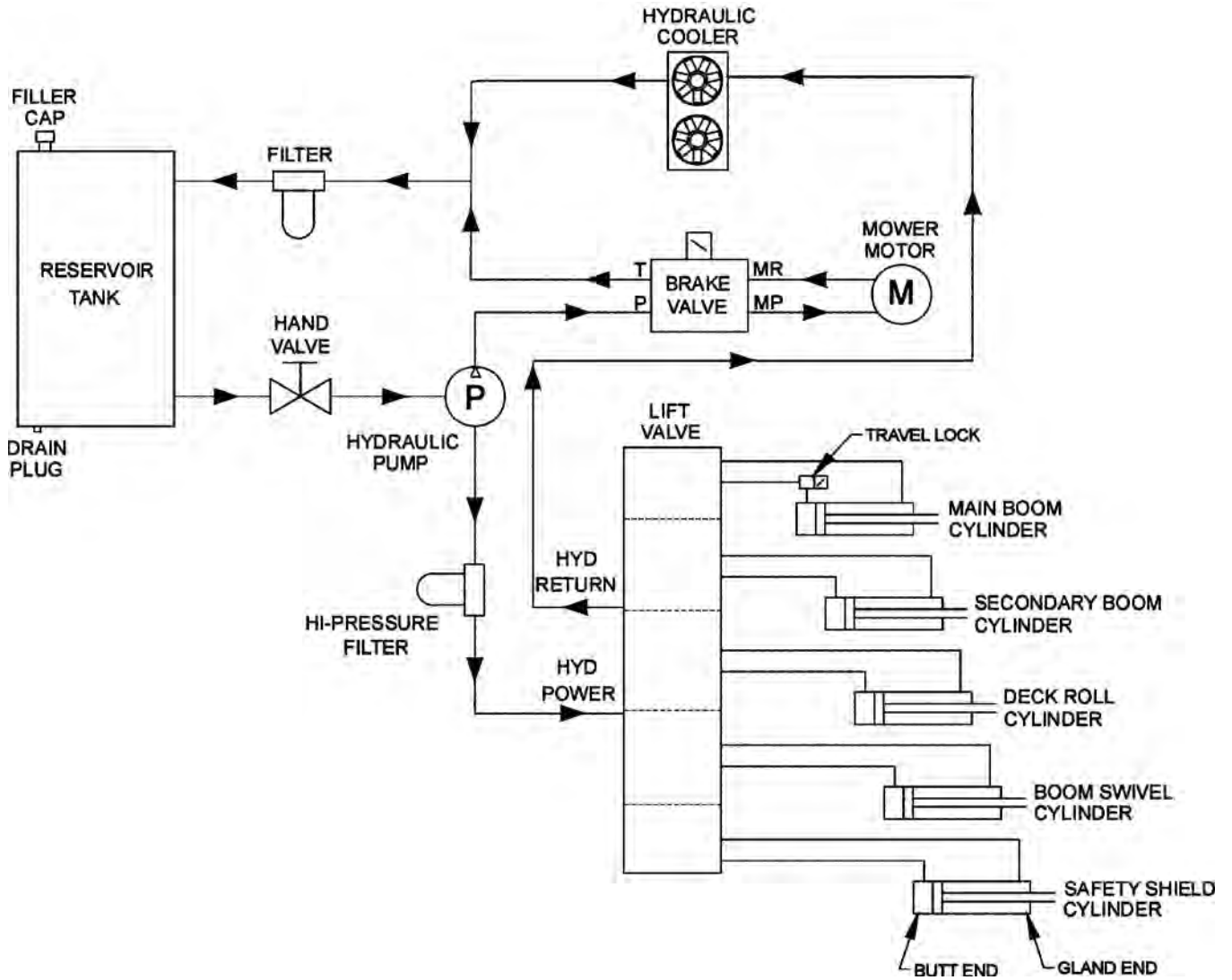

(ASM-TRK-0013)



ASSEMBLY

HITCH ASSEMBLY

1. Measure and make cut as shown in DETAIL C.
2. Weld Item 4 onto Item 1 then weld Item 5 to Items 1 and 4.
3. Weld Items 2 and 3 last.
4. Measure and make $\text{Ø}2.00$ cut above the Hitch Receiver as shown below. (ASM-TRK-0011)

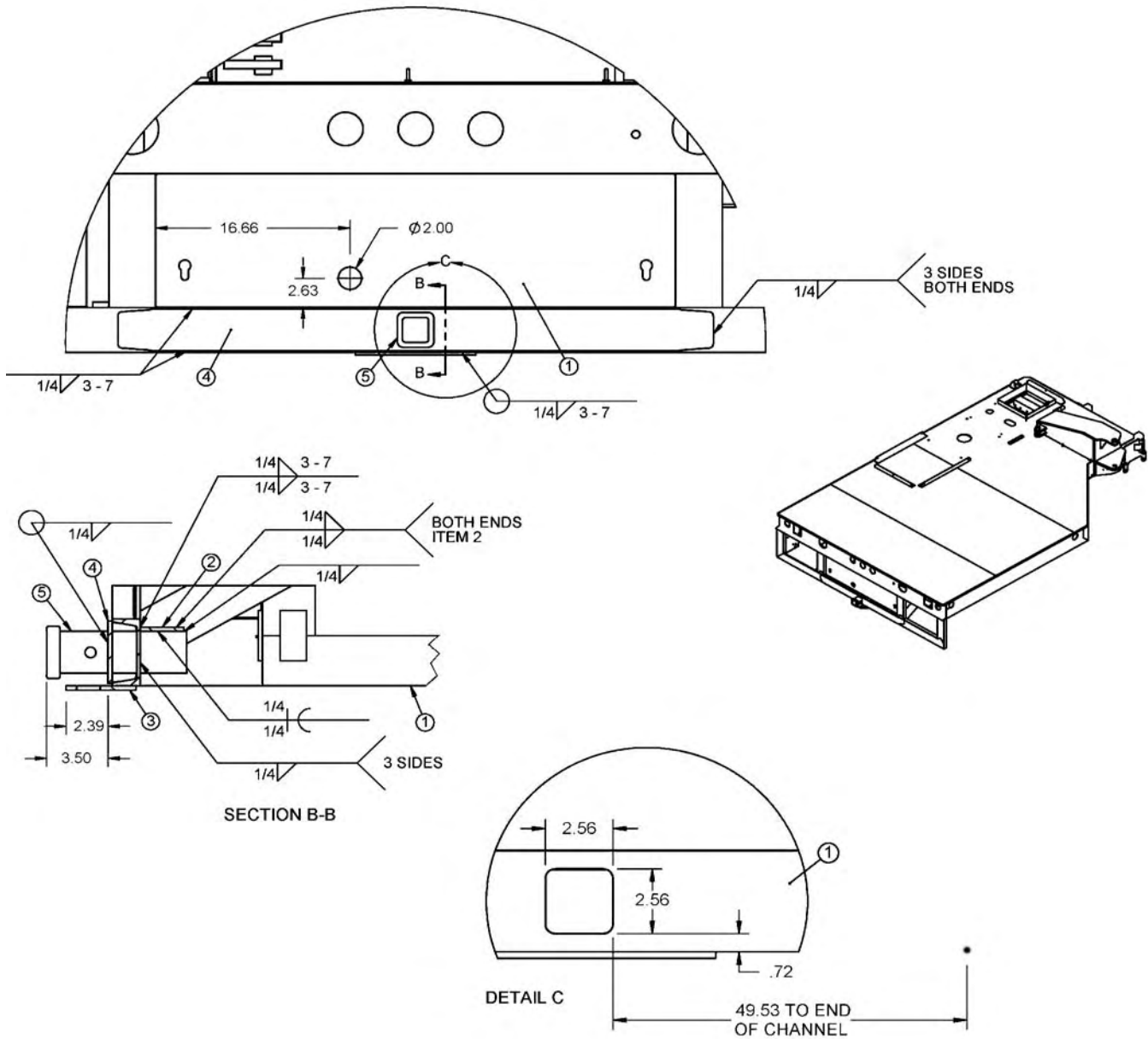

ITEM	PN	QTY	DESCRIPTION
1	REF	*	MAINFRAME
2	06401438	1	PLATE, TOP, HITCH
3	06401467	1	PLATE, HITCH, SAFETY
4	06411115	1	PLATE, COVER, HITCH
5	06520421	1	HITCH



ASSEMBLY

REAR HITCH WIRING

1. You will need to locate the wires supplied with the truck for the rear Hitch.
2. First, cut the sealed ends off of the truck wires for the Hitch and strip them back approximately 3/8".
3. Add a Heat Shrink Butt connector to each of these wires.
4. Strip approximately 3/8" and splice the extending wire to the existing wires as shown below.
5. Crimp the Butt Connector to the splice making sure it covers all of the exposed wire.
6. Apply heat to the Butt Connector to shrink it and cover the exposed wire.
7. Repeat steps 4 thru 6 for the rest of the wires.
8. Strip approximately 3/8" and attach the wires to the Hitch Connector following the diagram below.

WIRE COLOR KEY

EXISTING WIRE	EXTENSION WIRE	PIN NUMBER	FUNCTION
YELLOW	YELLOW, 16GA	5	LEFT TURN & BRAKE
GREEN	GREEN, 16GA	6	RIGHT TURN & BRAKE
ORANGE	ORANGE, 16GA	4	BATTERY CHARGE
BROWN	BROWN, 16GA	3	PARK LAMPS
BLUE	PURPLE, 16GA	2	TRAILER BRAKES
GREY/BROWN	GREY, 16GA	7	REVERSE LIGHTS
BLUE/ORANGE	N/A	N/A	HIGH BRAKE LAMP
WHITE	WHITE, 14GA	1	GROUND

(ASM-TRK-0019)

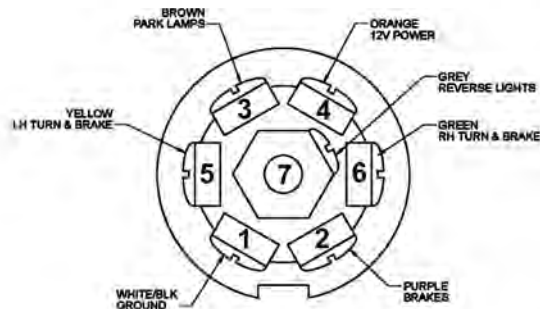
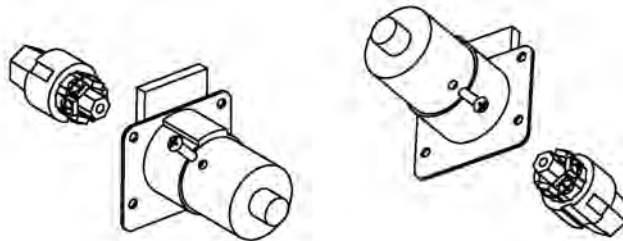

WIRE COLORS SHOWN ARE EXISTING TRUCK WIRES, NOT THE EXTENDING WIRES



ASSEMBLY

DOOR SAFETY SWITCH

Locate and drill the 2 holes on the right side of seat bracket $\text{Ø}3/16''$ as shown in picture below. These will be the pilot holes for the 2 self-tapping screws used to mount the safety switch mounting bracket. Mount the bracket and safety switch using the hardware supplied, as noted in the Parts Section. (ASM-TRK-0041)



BACK-UP ALARM

Locate the 2 holes on the truck chasis rear side as shown in picture below. These will be the mounting holes for the 2 mounting bolts of the alarm backup. Mount the bracket and safety switch using the hardware supplied, as noted in the Parts Section.

(ASM-TRK-0015)

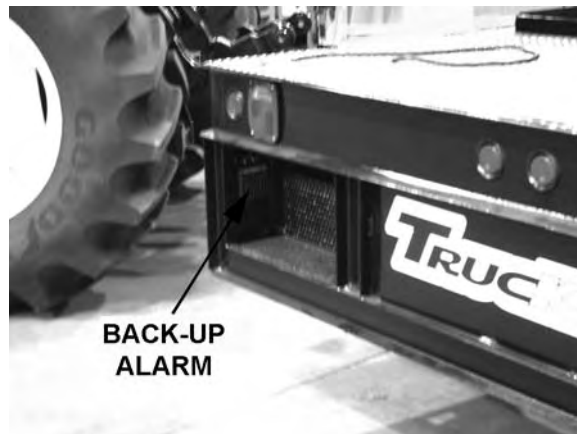

ASSEMBLY

SWIVEL SAFETY SWITCH

Locate the 2 holes on the right side of truck bed and underneath of swivel shown in picture below. These will be the mounting holes for the 2 mounting bolts of the limit switch. Mount the limit switch using supplied hardware as shown in Parts Section. Mount the loop on the limit switch as shown below. Make sure that the loop is on the front side of switch post.

(ASM-TRK-0016)

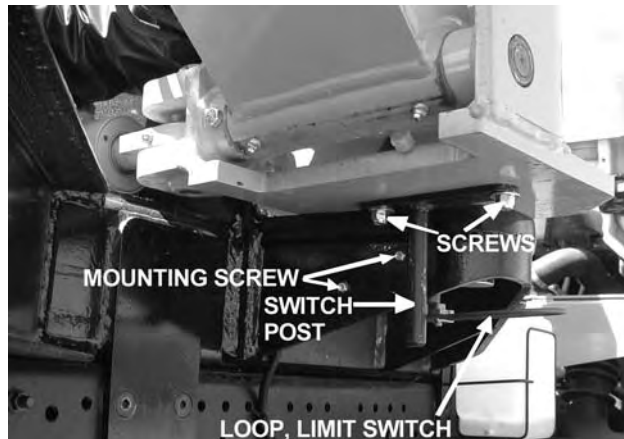

ASSEMBLY

FUEL TANK SENDING UNIT MODIFICATION

1. Remove the sending unit from the fuel tank. Be careful to save the hardware.
2. Locate and disengage the fuel line from the side of the bowl at the bottom of the sending unit.
3. Cut a piece of 3/8" hose as shown below.
4. Attach the hose to the end of the fuel line and place it in the bottom of the bowl as shown below.
5. Reattach the sending unit to the fuel tank with the hardware from which it was removed.

(ASM-TRK-0017)

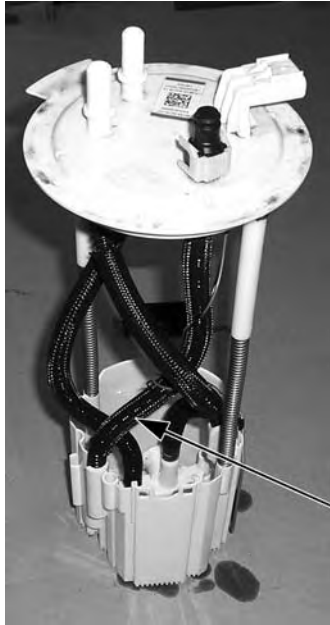

**SENDING UNIT
BEFORE
MODIFICATION**

FUEL LINE



**FUEL LINE
LOCATED IN BOWL**

**SENDING UNIT
AFTER MODIFICATION**



ASSEMBLY

PREFORMED FUEL LINE CLAMPING

1. Measure and mark 2" from the inside truck rail on both of the cross members as shown.
2. Measure and mark 3/4" from the front edge of each cross member perpendicular to the truck rails as shown below.
3. Drill a $\text{Ø}5/32$ " hole in each cross member at the intersecting lines.
4. Install the tubes and clamps using the self-tapping machine screws provided.

(ASM-TRK-0018)



ASSEMBLY

BOOM JOYSTICK CONTROL CALIBRATION

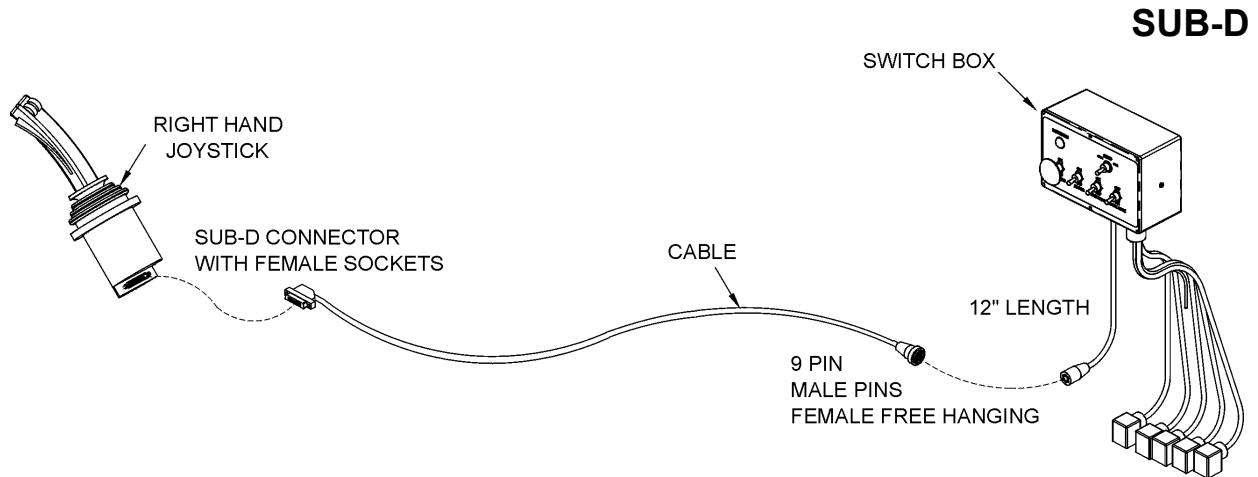

This Electronic control valve is now equipped with higher-resolution actuators on Main Boom, Secondary Boom, Deck Roll, and Swivel functions. These actuators have “active fault monitoring”. The Deck Shield section does not have “active fault monitoring”. The joystick is unchanged and provides a ratio-metric voltage signal. The neutral signal voltage is half or 50% of tractor supply voltage. A 25% signal voltage will shift the valve spool to full “A-Port”, and 75% signal voltage will shift the spool to full “B-Port” in the Main, Secondary, and Swivel valve sections. On the Deck Roll function a 34% signal voltage will shift the valve spool to full “A-Port” and a 68% signal voltage will shift the spool to full “B-port”. If an actuator with active fault monitoring receives a signal from the joystick that is less than 15% or greater than 85% of supply voltage the actuator will “fault out” and shut down. Also, if there is an internal failure in the actuator or if the spool position is greater than that specified by the signal voltage from the joystick, the actuator will “fault out” and shut down. An “active fault” condition causes the actuator to drive the spool to neutral, shut down, and activate a “red” LED on the top of the actuator. The active fault can be canceled by simply cycling the Master Switch “OFF” and then “ON”, which resets the fault monitoring, and causes the LED on top of the actuator be “green” again.



The joystick control is equipped with signal adaption potentiometers.

These provide the capability to individually adjust the oil flow to each boom function. It is important that the boom functions do not travel too fast. Excessive boom speed can reduce the stability of the unit and decrease operator control.

Note: Use a Phillips screw driver and be sure to adjust the screws carefully! DO NOT turn the potentiometers beyond their stopping point, potentiometers are very delicate! Turning the “A” or “B” port potentiometers clockwise increases the oil flow to increase the boom function speed, and turning them counterclockwise decreases the oil flow to decrease the boom function speed. See the graphic on the next few pages for help in adjusting.



ASSEMBLY

BOOM JOYSTICK CONTROL CALIBRATION (CONTINUED)

Run tractor at normal operating RPM to adjust the settings as follows.

Set the dead band compensation potentiometer first.

Set the dead band compensation potentiometer at 50%, or halfway between full clockwise and full counter-clockwise.

Setting Signal Adaptation Potentiometers:

Disconnect the Deutsch connectors from the actuators of the valve. Use a V olt/Ohm meter to measure signal voltage and adjust the signal adaptation potentiometers as needed. Pin #4 is tractor supply voltage. Pin #1 is signal voltage from the joystick, and pin #3 is ground. First, measure supply voltage between pins 4 and 3. Then measure signal voltage between pins 1 and 3 while indexing the joystick function fully in both the "A" and "B" port direction. Divide the signal voltage by the supply voltage to get signal voltage as a % of supply voltage. This percentage should not be less than 25% or greater than 75% for the Main Boom, Secondary Boom, or Swivel function. This percentage should not be less than 30% or greater than 62% for the Deck Roll function. Note these initial settings for the Deck Roll function should prevent the spool from shifting into float. *After making this first adjustment to deck roll if the spool still goes into float, adjust the "B" port screw additionally counterclockwise.*

Reconnect Deutsch connectors on control cables to actuators on Electronic valve. Run tractor until hydraulic system is at operating temperature. Now refine the adjustments of the signal adaptation potentiometers for both "A" and "B" ports for all proportional functions to achieve the following function times. Note: turning potentiometer clockwise increases the flow or the function speed, and turning them counter-clockwise decreases the flow or the function speed. Note, if during this procedure the trim potentiometer is set to full "counterclockwise" but the function is still too fast, use the mechanical stops at the manual actuator end of the valve section to further limit flow. Turn limit screw in or clockwise to limit flow. The upper limit screw limits flow to "B-port", and the lower limit screw limits flow to "A-port". However DO NOT adjust the limit screw on "B-port" of deck roll function. Limiting "B-port" will prevent "float" function.



ASSEMBLY

BOOM JOYSTICK CONTROL CALIBRATION (CONTINUED)

MAIN BOOM: “A” Port, Boom Up: 7-9 Seconds

(Note: Extend secondary boom completely; roll deck to be level with ground, and lower main boom until deck is on ground. Now index main boom “up” function and determine the time required for main boom to rise completely.)

“B” Port, Boom Down: 6-8 Seconds

(Note: Extend secondary boom completely, roll deck to be level with ground, and raise the main boom to “full up”. Then index the main boom “down” function to determine the amount of time required for the deck to contact the ground. CAUTION: Stop the boom just as the deck contacts the ground.)

SECONDARY

BOOM: “A” Port, Boom Out: 8-10 Seconds

(Position main boom full up, roll deck out until deck cylinder is fully retracted, and bring secondary boom in completely. Then index the secondary boom “out” function and determine the time required for boom to extend out completely.)

“B” Port, Boom In: 8-10 Seconds

(Position the main boom full up, roll deck out until deck cylinder is fully retracted, and extend secondary boom completely. Then index the secondary boom “in” function and determine the time required for boom to come in.)

DECK ROLL: “A” Port, Deck Out: 7-9 Seconds

(Raise main boom to vertical, extend secondary boom out slightly so that deck can be articulated without contacting the main boom, and roll deck in until deck cylinder is completely extended. Then index the deck roll “out” function and determine the time required for the deck to roll out.)

“B” Port, Deck In: Target 7-9 Seconds (but DO NOT use Limit Screw)

(Raise main boom to vertical, extend secondary boom out slightly so that deck can be articulated without contacting the main boom, and roll deck out until deck cylinder is completely retracted. Then index the deck roll “in” function and determine the time required for the deck to roll in.)

BOOM

SWIVEL: “A” Port, Boom Aft: 11-13 Seconds

(Extend booms completely; rotate head to be level with ground, lower main boom until deck is just above ground, and swivel boom full forward. Then index the boom swivel “aft” function and determine the time required for the boom to swivel full aft. Use caution when doing this, stop boom before main boom contacts tire.)

“B” Port, Boom Forward: 11-13 Seconds

(Extend booms completely, rotate head to be level with ground, lower main boom until deck is just above ground, and swivel boom aft until near tire. Then index the boom swivel “forward” function and determine the time required for the boom to swivel full forward.)

(ASM-TRK-0020)



ASSEMBLY

BOOM JOYSTICK DIAGRAM (ASM-C-0082A)

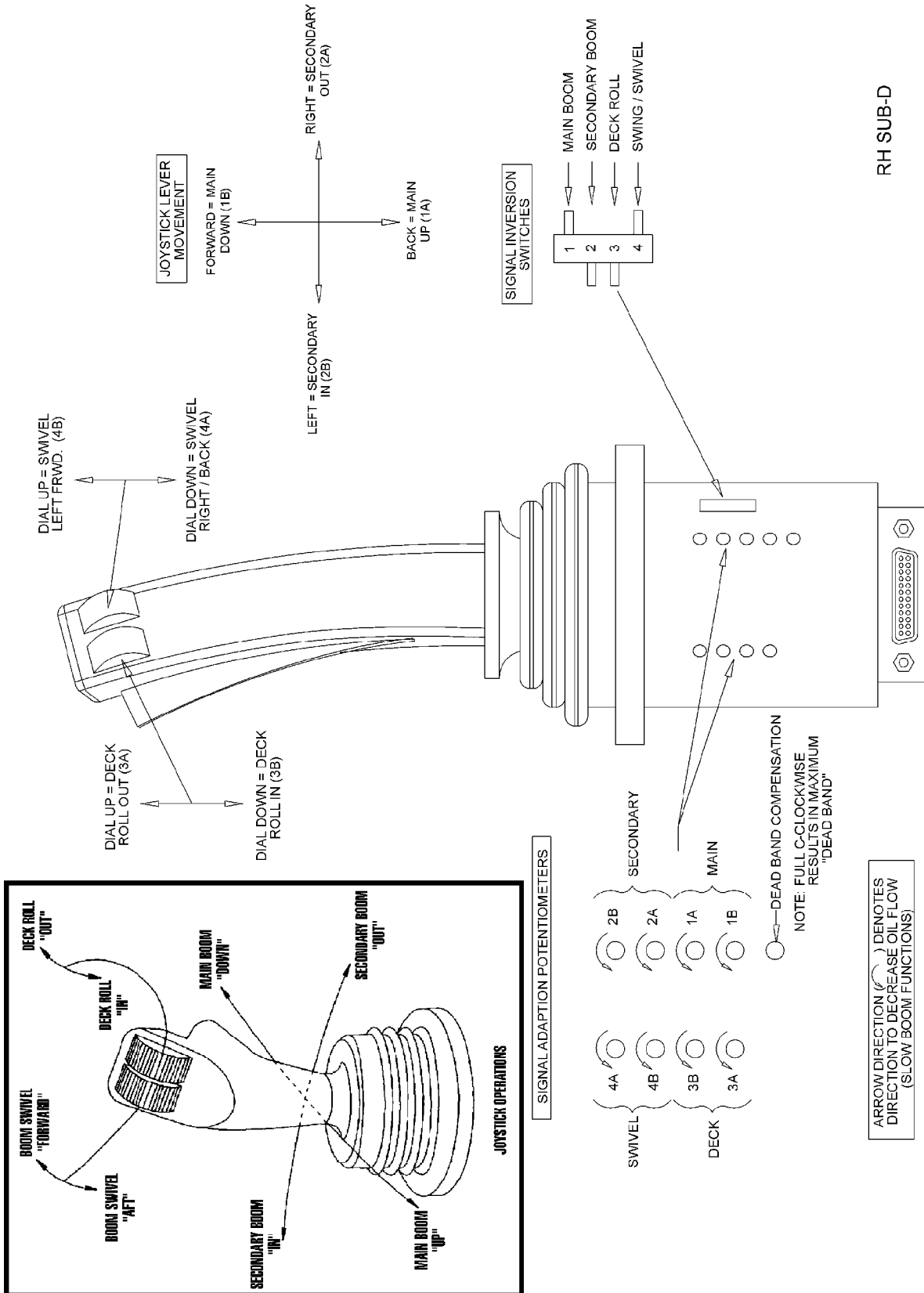

ASSEMBLY

AIR SYSTEM MOUNTING

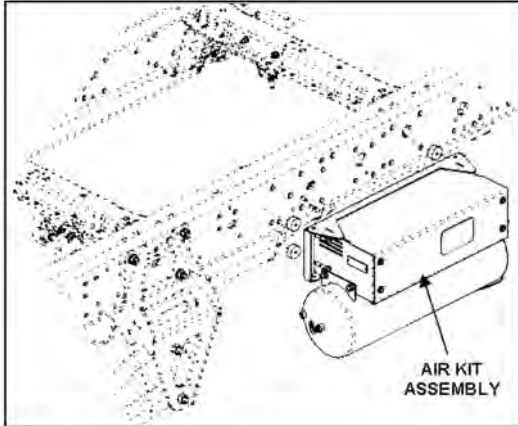

The Ultraride® Air Kit is assembled and shipped as a one-piece unit ready for mounting to the vehicle.

Mount the Air Kit to the side of the frame as shown in the illustrations. Use the supplied rubber isolators and 5/16" nuts and bolts to fasten the kit. Torque to 15-20 FT-LBS. Some drilling is required. **Do not over tighten the fasteners** to ensure proper clearance and isolation from the rubber isolators.

See the image below for location of the hole pattern. Locate bolt on the left, then measure down from the top of the chassis 6".

(ASM-TRK-0022)

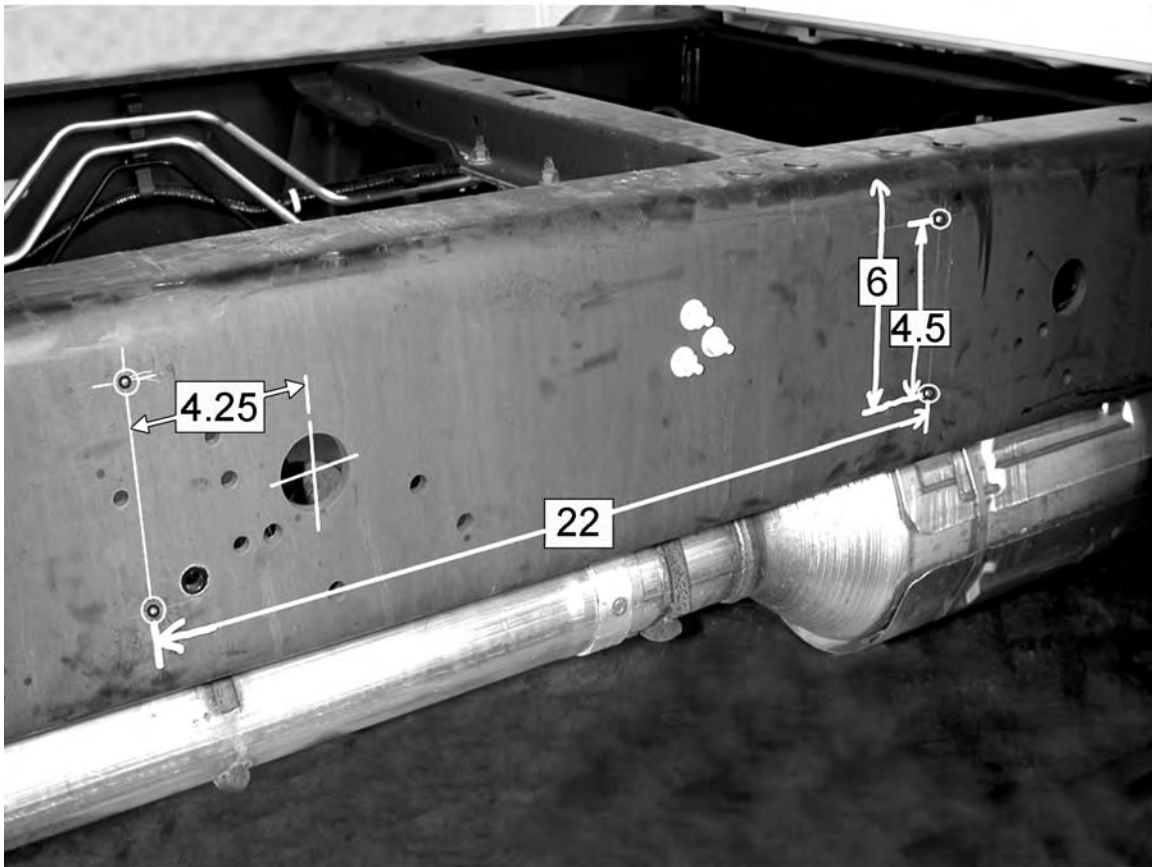

ASSEMBLY

AIR RIDE HOSE DIAGRAM

(ASM-TRK-0025)

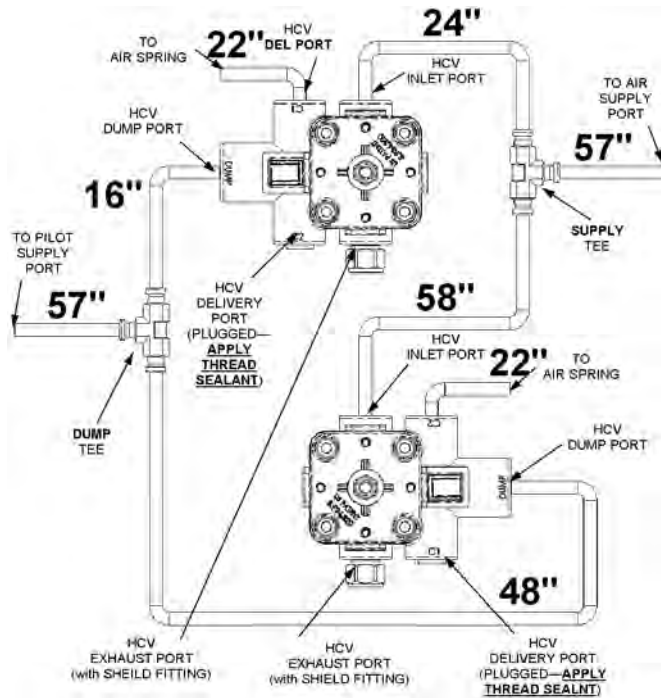

ASSEMBLY

COOLER MOUNTING & CLEANING

Remove the side cover of the Engine Cage. Mount the cooler to the mounting brackets with four capscrews. Attach the fittings and hoses to the cooler as shown in the Parts Section. To clean the cooler, remove the side cover, loosen the top two capscrews and carefully swing the cooler out. The hardware does not have to be removed. (ASM-TRK-0040)



ASSEMBLY

ENGINE CAGE MODIFICATION

The side cover of the Engine Cage will have to be cut as shown below to allow the cooler hoses to be routed to the bulkhead. The Engine Pedestal will also have to be cut as shown below for the bulkheads to be attached. After cutting the Side Engine Cover, trimlock needs to be applied to the cut edges. (ASM-NH-0021)

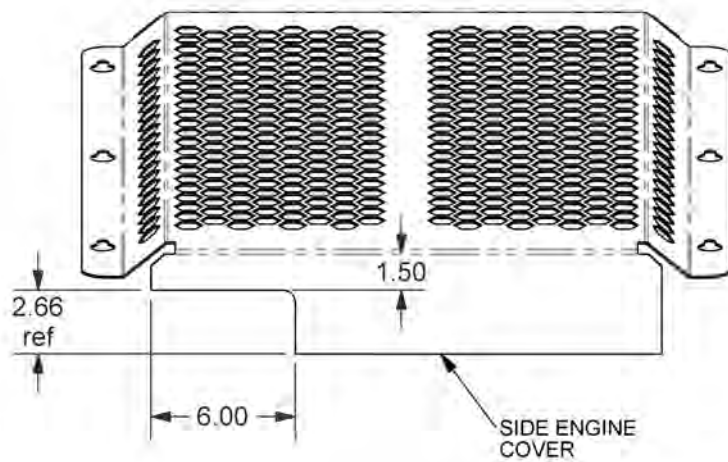
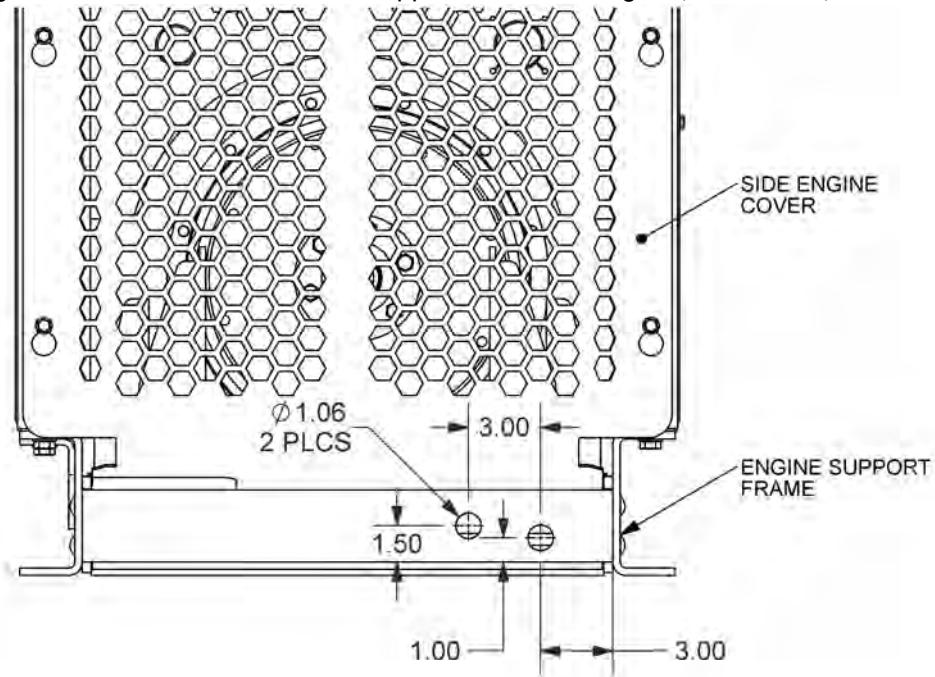

ASSEMBLY

FINAL PREPARATION FOR OPERATION

Place operators safety information decal book and operation manual inside the truck cab where they are clearly visible to the operator. These manuals should be understood by each operator of the machine in conjunction with the safety and operation section of this book. The manuals are to be maintained in good condition as a reminder to the operator, and should be replaced if damaged.

Finally, all bosses, pins and pivot points will need to be greased as instructed in the maintenance section of this manual. The hydraulic reservoir can also be filled with the recommended fluid (see maintenance section) and the filter installed in the top of the tank. Double check all fittings and fasteners BEFORE starting truck. Also secure any loose hoses together with zip ties and wrap with split hoses where friction may occur on the hoses.



BEFORE starting or operating the mower you must read and understand the safety and operation sections of this manual completely.

BE SURE THE BALL VALVES ARE OPEN! Start mower motor and allow instruments to stabilize. Using a piece of paper or cardboard as noted in the safety and maintenance sections, check all fittings and connections for hydraulic leaks.

If a leak is found, you must shut down the mower motor, set the cutter on the ground. Before attempting to fix the leak, you must actuate the lift valve handles several times to relieve any pressure in the lines.

Before operating the mower, the cutter head and boom should be slowly moved throughout the full range of motion. Watch for any condition that would cause pinching or excess stress on the hoses. Correct any condition that occurs in which the hoses may be damaged. While checking motion limits, you should also check that the control circuits are connected correctly according to the operators manual and the motion of the boom.

MOWER TESTING

Take the truck to a place free of loose objects on the ground. Operate the cylinders through their full range of motion again to clear the lines of air. Follow the instructions in the operation section to operate the mower. Vibration of the mower should be minimal at all times. After a 5 minute test run, the knife bolts on a rotary mower should be retorqued and once again after the first few hours of operation.

If any parts of this assembly section, or any other section of this manual are not clearly understood you must contact your dealer or the address on the front of this manual for assistance! (ASM-TRK-0024)



OPERATION SECTION

Operation Section 3-1

OPERATION

TRUCKAT® TRUCK MOUNTED BOOM MOWER OPERATING INSTRUCTIONS

Tiger TruckKat® Truck Mounted Boom Mowers are manufactured with quality material by skilled workers. The TruckKat® is designed to attach to a tractor and operate various heads for a wide range of vegetative maintenance applications. The truck, boom and mowing heads are equipped with safety warning decals, protective deflectors, shields, guards, and other safety features to provide operator and passerby protection, however, no shielding is 100% accurate. ALL safety equipment and safety warning decals must be maintained on the unit in good operational condition at all times.

It is the operator's responsibility to be knowledgeable of all potential operating hazards and to take every reasonable precaution to ensure oneself, others, animals, and property are not injured or damaged by the boom unit, tractor or a thrown object. Do not operate the boom and attached head if bystanders, passersby, pets or livestock are within 300 feet of the unit.

This section of the Operator's Manual is designed to familiarize, instruct, and educate operators to the safe and proper use of the boom and attached head. Pictures contained in this section are intended to be used as a visual aid to assist in explaining the operation of a Boom and are not specific to a TruckKat®. Some pictures may show shields removed to enhance visual clarity. NEVER operate the boom unit without all safety equipment in place and in good operational condition. The operator must be familiar with the boom unit and tractor operation and all safety practices before beginning operation. Proper operation, as detailed in this manual, will help ensure years of safe and satisfactory use of the TruckKat®.

(1) OPERATOR REQUIREMENTS	3-4
(2) TRUCK REQUIREMENTS	3-5
(2.1)Truck Operator Seating	3-5
(2.2)Operator Thrown Object Protection	3-6
(2.3)Truck Warning Lighting.....	3-6
(2.4)Truck Ballast.....	3-7
(3) ENTERING AND EXITING THE OPERATOR STATION	3-7
(3.1)Boarding the Truck	3-7
(3.2)Dismounting the Truck	3-8
(4) PRE-OPERATION INSPECTION AND SERVICE	3-8
(4.1)Truck and Auxiliary Engine Pre-Operation Inspection/Service.....	3-9
(4.2)Boom Unit Pre-Operation Inspection/Service	3-9
(4.3)Hydraulic Pump/Oil Reservoir Inspection.....	3-9
(4.4)Hydraulic Hose/Line Inspection.....	3-10
(4.5)Boom Mount Assembly Inspection.....	3-10
(4.6)Boom Arm Assembly Inspection	3-10
(4.7)Rotary Head Inspection.....	3-10
(4.8)Flail Head Inspection.....	3-10
(4.9)Clean Cut Saw Blade Inspection.....	3-11
(4.10)Ditcher Head Inspection.....	3-11
(5) TRUCK OPERATION	3-11
(5.1)Truck Controls.....	3-11
(5.2)Before Starting the Truck Ensure the Following	3-11

(OPS-TRK- 0010)

OPERATION

(6) AUXILIARY ENGINE OPERATION	3-12
(6.1) Starting Engine	3-12
(6.2) Running Engine	3-12
(6.3) Stopping Engine	3-12
(6.4) Multi-alarm Safety Shutdown Control	3-12
(6.5) Auxiliary Engine Controls and Instrument Panel	3-13
(7) SWITCH BOX AND JOYSTICK CONTROLS	3-14
(7.1) Switch Box	3-14
(7.2) Joystick	3-15
(7.3) Joystick Functions	3-16
(7.4) Lift Valve System	3-17
(8) GRID HEATER OPERATION	3-18
(8.1) B3.3 Series Engine	3-18
(9) MOWER OPERATION	3-18
(9.1) Foreign Debris Hazards / Overhead Obstructions	3-19
(9.2) Bystander/Passersby Precautions	3-20
(9.3) Operating Speed and Ground Speed	3-20
(9.4) Operating the Mower	3-21
(9.5) Safety Switches	3-21
(9.6) Mowing at Ground Level	3-21
(9.7) Cutting Brush and Trees	3-22
(9.8) Boom Rotary Cutter	3-22
(9.9) Boom Flail Cutter	3-23
(9.10) Clean Cut Saw Blade	3-23
(9.11) Ditcher Head	3-23
(9.11) Shutting Down the Mower	3-23
(9.13) Returning Mower Head to Transport Position	3-24
(10) TRUCK BOOM MOWER STORAGE	3-25
(11) TRANSPORTING THE TRUCK BOOM MOWER	3-26
(11.1) Transporting on Public Roadways	3-26
(11.2) Hauling the Truck Boom Unit	3-27

(OPS-TRK-0011)

READ AND UNDERSTAND THE ENTIRE OPERATING INSTRUCTIONS AND SAFETY SECTION OF THIS MANUAL AND THE TRACTOR MANUAL BEFORE ATTEMPTING TO USE THE TRACTOR AND IMPLEMENT. If you do not understand any of the instructions, contact your nearest authorized dealer for a full explanation. Pay close attention to all safety signs and safety messages contained in this manual and those affixed to the implement and tractor. (OPS-U-0001)

OPERATION

READ, UNDERSTAND, and FOLLOW the following Safety Messages. Serious injury or death may occur unless care is taken to follow the warnings and instructions stated in the Safety Messages. Always use good common sense to avoid hazards. (SG-2)



Si no lee ingles, pida ayuda a alguien que si lo lea para que le traduzca las medidas de seguridad. (SG-3)

¡ LEA EL INSTRUCTIVO!



OPERATION

1. OPERATOR REQUIREMENTS

Safe operation of the unit is the responsibility of a qualified operator. A qualified operator has read and understands the implement and tractor Operator's Manuals and is experienced in implement and tractor operation and all associated safety practices. In addition to the safety messages contained in this manual, safety signs are affixed to the implement and tractor. If any part of the operation and safe use of this equipment is not completely understood, consult an authorized dealer for a complete explanation.

If the operator cannot read the manuals for themselves or does not completely understand the operation of the equipment, it is the responsibility of the supervisor to read and explain the manuals, safety practices, and operating instructions to the operator.

Safe operation of equipment requires that the operator wear approved Personal Protective Equipment (PPE) for the job conditions when attaching, operating, servicing, and repairing the equipment. PPE is designed to provide operator protection and includes the following safety wear:

PERSONAL PROTECTIVE EQUIPMENT (PPE)

- Always Wear Safety Glasses
- Hard Hat
- Steel Toe Safety Footwear
- Gloves
- Hearing Protection
- Close Fitting Clothing
- Respirator or Filter Mask (depends on operating conditions) (OPS-U-0002)

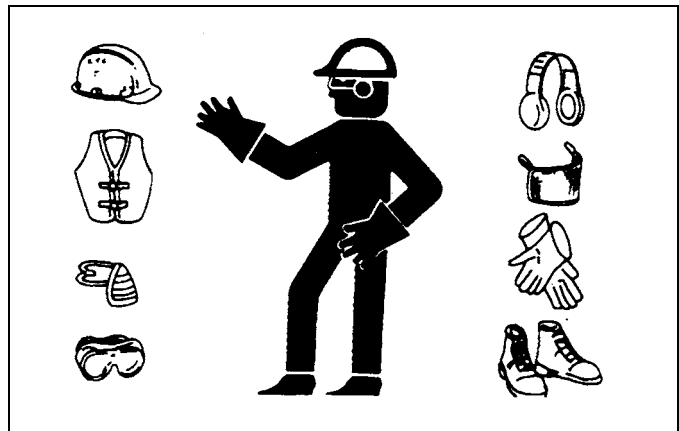

OPERATION

⚠ DANGER

NEVER use drugs or alcohol immediately before or while operating the Tractor and Implement. Drugs and alcohol will affect an operator's alertness and coordination and therefore affect the operator's ability to operate the equipment safely. Before operating the Tractor or Implement, an operator on prescription or over-the-counter medication must consult a medical professional regarding any side effects of the medication that would hinder their ability to operate the Equipment safely. NEVER knowingly allow anyone to operate this equipment when their alertness or coordination is impaired. Serious injury or death to the operator or others could result if the operator is under the influence of drugs or alcohol. (SG-27)

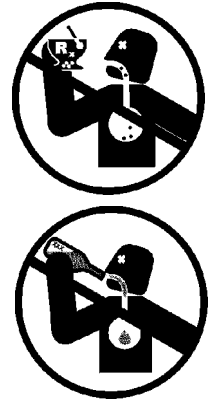

OPERATION

2. TRUCK REQUIREMENTS

The truck is equipped with safety features to provide operator protection and to warn passersby and motorists of the unit's presence while mowing. Maintain all safety features in good operational condition at all times. Never compromise your safety and the safety of others by operating a unit with broken, malfunctioning, or missing safety equipment. (OPS-TRK-0001)

2.1 Truck Operator Seating

The truck is equipped with dual steering controls. The right side seat is for mowing only and the left side driving controls are for transporting the truck between locations. DO NOT ATTEMPT TO TRANSPORT THE TRUCK FASTER THAN 15 MPH FROM THE RIGHT SIDE DRIVERS CONTROLS AND DO NOT ATTEMPT TO OPERATE THE MOWER WHEN SEATED AT THE LEFT SIDE. Both seats are equipped with seat belts. The seat belt must be worn at all times the truck is driven. (OPS-TRK-0002)



2.2 Operator Thrown Object Protection

The truck is equipped with a right side protective polycarbonate door panel and cab rack to shield the operator from thrown and falling objects. Replace the protective door when broken, cracked or its visibility becomes impaired because of scratches, gouges, or other damage. (OPS-TRK-0003)



OPERATION

2.3 Truck Warning Lights

The truck is equipped with a warning beacon, light bar and flashing lights to alert motorists and passersby of the truck's presence when mowing. Warning lighting must be turned on by the operator before starting to mow. The warning beacon control switch is mounted in the auxiliary engine control box. The light bar switch is located in a separate control box mounted below. (OPS-TRK-0004)



2.4 Truck Ballast

To provide traction when operating on flat surfaces and inclines not greater than 5°, the truck is equipped with left side counterweights. These counterweights will ensure that the left rear tire exerts down force on the ground, which is required for traction when the boom is fully extended. A truck that does not meet these criteria may lose traction when the boom is fully extended. (OPS-TRK-0005)

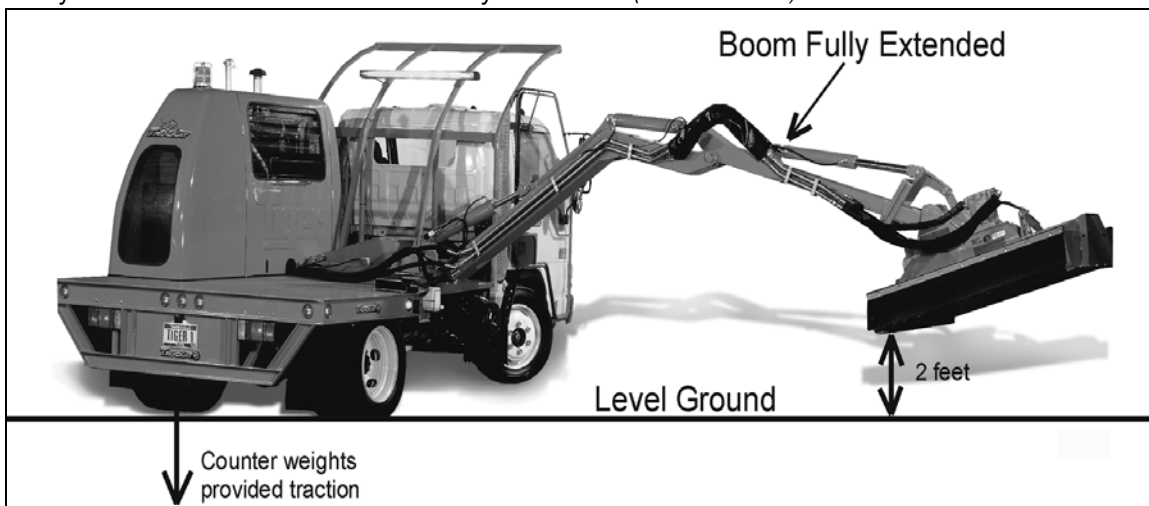

3. ENTERING AND EXITING THE OPERATOR STATION

The operator must read and completely understand this manual, the truck operator's manual and the auxiliary engine operator's manual before starting any mowing operation. If any of the operating instructions, safety warnings and safety decals are not completely understood, consult an authorized dealer for a complete explanation. (OPS-TRK-0006)

OPERATION

⚠ WARNING Allow passengers only in situations where their presence is involved in the Mowing operation (operator training, supervision, maintenance or inspection). Never carry passengers whose presence distracts from the safe operation or transport of the Truck and Mower. Passengers must be seated securely and belted in the cab's passenger seat. Passengers must be instructed to keep clear of steering wheel and foot pedals. Never allow any person to ride on any other location of the Truck during operation or transport. (STM-11)

3.1 Boarding the Truck

Use both hands and equipped handrails and steps for support when boarding the truck. Never use truck control levers for support when boarding. Seat yourself in the seat and secure the seat belt. (OPS-TRK-0007)

⚠ DANGER Do not attempt to mount the Truck while the Truck is moving or Mower is running. Never attempt to mount a runaway Truck. Serious injury or death may occur from being run over by a moving Truck. (STM-19)

3.2 Dismounting the Truck

Before exiting the truck, disengage the mower and wait for blade rotation to come to a complete stop. Retract the boom and stow the mower head on the truck bed and engage the transport lock. Park the truck on a level surface, set the transmission in park and apply the parking brake. Shut down the truck and auxiliary engines, remove the keys, and wait for all motion to come to a complete stop before exiting the operator's station. NEVER dismount until the truck, the engines and mower head rotation have come to a complete stop.

Use hand rails and steps when exiting the truck. Be careful of your step and use extra caution when mud, ice, snow or other matter has accumulated on the steps or hand rails. Use all handrails and steps for support and never rush or jump off the truck.

NOTE: *The truck is equipped with an Operator Presence and Right Door Safety Switch. The safety switch will stop the mower if the operator is not seated in the operator's seat or if the right side door is opened while the mower is running. (OPS-TRK-0008)*

⚠ DANGER BEFORE leaving the Truck seat, always engage the parking brake, stop the Auxiliary and Truck engines, remove the key, and wait for all moving parts to stop. Never dismount the Truck if it is moving or while either the Auxiliary or Truck engine is running. Opening the Truck door while the mower is operating will activate the mower brake valve stopping the mower blades within 10 seconds. (STM-23)

4. PRE-OPERATION INSPECTION AND SERVICE

Before each use, a pre-operation inspection and service of the entire truck boom mower unit must be performed. This includes routine maintenance and scheduled lubrication, inspecting that all safety devices are equipped and functional, and performing needed repairs. DO NOT operate the unit if the pre-operation inspection reveals any condition affecting safe operation. Perform repairs and replacement of damaged and missing parts as soon as noticed. By performing a thorough pre-operation inspection and service, valuable down time and repair costs can be avoided. (OPS-TRK-0009)

OPERATION

WARNING

Periodically inspect all moving parts for wear and replace when necessary with authorized service parts. Look for loose fasteners, worn or broken parts, and leaky or loose fittings. Make sure all pins have cotter pins and washers. Serious injury may occur from not maintaining this machine in good working order. (SG-21)

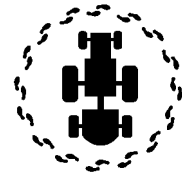

DANGER

Replace bent or broken blades with new blades. NEVER ATTEMPT TO STRAIGHTEN, WELD, OR WELD HARDFACING ON BLADES SINCE THIS WILL LIKELY CRACK OR OTHERWISE DAMAGE THE BLADE WITH SUBSEQUENT FAILURE AND POSSIBLY CAUSE SERIOUS INJURY FROM THROWN BLADES. (SGM-10)

4.1 Truck and Auxiliary Engine Pre-Operation Inspection/Service

Refer to the truck and auxiliary engine operator's manual to ensure a complete pre-operation inspection and scheduled service is performed according to the manufacturers' recommendations. The following are some of the items that require daily service and inspection: (OPS-TRK-0012)

- Tire condition/air pressure
- Wheel lug bolts
- Steering linkage
- Lights and signals are clean and functional
- Seat belts are in good condition
- No oil leaks
- Radiators are free of debris
- Engine oil levels and condition
- Engine coolant levels and condition
- Power brake fluid level
- Power steering fluid level
- Fuel condition and level
- Sufficient lubrication at all lube points
- Air filter condition
- Clean mirrors and inspect for damage



4.2 Boom Unit Pre-Operation Inspection/Service

Inspect and service the boom arm and head at the start of each day. Damaged and/or broken parts should be repaired and/or replaced immediately. To ensure the unit is ready for operation, conduct the following:

- Ensure the Manual Canister is secured in the truck cab and contains the Operator's Manual.
- Ensure all decals are in place and legible. Replace missing, worn, and nonlegible decals.

NOTE: *The Operator's Manuals and affixed Decals contain important instructions on the safe and proper use of the truck boom mower. Maintain these important safety features on the unit in good condition to ensure the information is available to the operator at all times. (OPS-TRK-0013)*

OPERATION

4.3 Hydraulic Pump/Oil Reservoir Inspection

- Check oil reservoir level and oil condition. Hydraulic oil level should be maintained between the tank sight gauges. Add universal hydraulic oil if low.
- Change hydraulic oil filter and oil according to maintenance schedule.
- Ensure there are no oil leaks and fittings are properly connected and tightened.
- Inspect condition of hydraulic pump.
- Inspect pump drive shaft from auxiliary engine.
- Inspect oil cooler condition. Clean plugged fins using pressurized air

(OPS-TRK-0014)

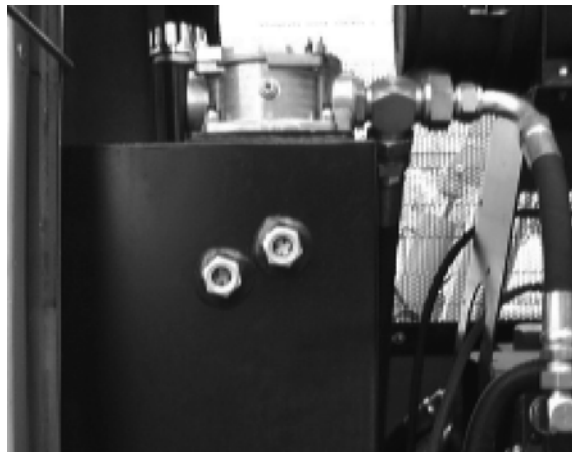

4.4 Hydraulic Hose/Line Inspection

- Check for hydraulic leaks along hoses, cylinders, fittings, and connections.
- Replace any hose, fitting, tubing, etc. that is damaged and/or leaking.
- Ensure that hoses have not chafed against sharp edges. If they have, inspect condition and replace if necessary. Re-route any hose that has been chafing.
- If in doubt about the condition of a hose REPLACE IT. Hose failure can result in spillage of several gallons of hydraulic fluid and result in costly down time for repairs. (OPS-TRK-0015)

4.5 Boom Mount Assembly Inspection

- Inspect condition of boom arm mounting frames.
- Inspect condition of boom mounting bracket and arm swivel frames.
- Inspect condition of Inner Draft Beam Pin and Swivel Pin. Ensure pins are properly installed and secured in place with screws, lock washers, and nuts.
- Ensure all bolts and screws are in position and are properly torqued. (OPS-TRK-0016)

4.6 Boom Arm Assembly Inspection

- Inspect condition of each arm section weldment
- Ensure all pins are in place and secured in place with screws, lock washers, and nuts.
- Ensure all bolts and screws are properly installed and tightened.
- Check condition of bushings at pivot points. (OPS-TRK-0017)

OPERATION

4.7 Rotary Head Inspection

- Ensure all bolts are in place and properly torqued: spindle mounting bolts to deck 331 ft. lbs., disk mounting bolts to spindle 204 ft. lbs., and blade mounting bolts to disk 600 ft. lbs.
- Inspect blades and blade bolts for looseness and excessive wear. Blades must be replaced as complete sets to maintain carrier balance.
- Inspect thrown object protection (chain guard or rubber deflector). Replace any damaged or missing sections. Replace rubber deflector after no more than 1/3 width wear.
- Ensure the mower head is properly attached to the boom hitch. Refer to the assembly section for connecting the hitch and mower hydraulics.

(OPS-TRK-0018)

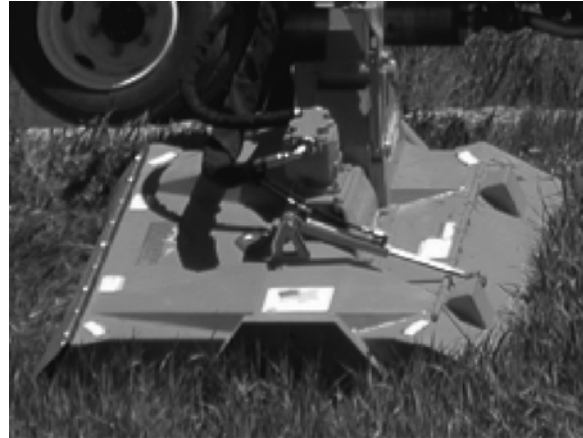

4.8 Flail Head Inspection

- Inspect condition of cutter knives and pins. Replace missing and broken knives. Only operate the unit with a full set of knives with comparable amount of wear to ensure cuttershaft balance.
- Inspect condition of thrown object rubber deflectors. Replace any missing and damaged sections. Replace rubber deflectors after no more than 1/3 width wear.
- Inspect condition of roller assembly and cutting height.
- Ensure the mower head is properly attached to the boom hitch. Refer to the assembly section for connecting the hitch and mower hydraulics. (OPS-TRK-0019)

4.9 Clean Cut Saw Blade Inspection

- Inspect condition and sharpness of blade teeth. Replace teeth if any carbide tip is missing. Use hand and arm protection when handling saw blade.
- Ensure all bolts are in place and properly torqued: spindle mounting bolts to deck 331 ft. lbs., and blade mounting bolts to spindle 204 ft. lbs.
- Ensure the mower head is properly connected to the boom hitch. Refer to the assembly section for connecting the hitch and head hydraulics. (OPS-TRK-0020)

4.10 Ditcher Head Inspection

- Inspect condition and sharpness of blades. Use hand and arm protection when handling ditcher blades.
- Ensure the ditcher head is properly attached to the boom hitch. Refer to the assembly section for connecting the hitch and head hydraulics. (OPS-TRK-0021)

5. TRUCK OPERATION

The operator must have a complete understanding of the placement, function, and operation of all truck controls before starting the truck. Review the truck operator's manual for detailed truck operating instructions. Only start the truck while seated and belted in the operator's seat. (OPS-TRK-0022)

OPERATION

5.1 Truck Controls:

- Locate the ignition key/switch.
- Locate the gear shift lever.
- Locate the light control lever.
- Locate the brake pedals.
- Locate the parking brake lever.
- Locate the boom joystick.
- Locate the master switch box.
- Locate the auxiliary engine control box. (OPS-TRK-0023)

5.2 Before Starting the Truck Ensure the Following:

- A pre-operation inspection and service according to the truck operator's manual has been performed.
- The parking brake is set.
- The truck is in park.
- The mower control switch is in the OFF position.
- The joystick master switch is in the OFF position. (OPS-TRK-0024)

▲ DANGER Never run the Truck or Auxiliary engine in a closed building or without adequate ventilation. The exhaust fumes can be hazardous and deadly to your health. If it is necessary to run the Truck or Auxiliary engine in an enclosed area, remove the exhaust fumes from the area to the outdoors with an exhaust pipe extension. If you do not have an exhaust pipe extension, or if it is not possible to use one, open doors and circulate outside air into the area. (STM-15)

▲ DANGER Start the Truck and Auxiliary engines only when seated and belted in the Truck's operator seat. Operate the Mower controls only while properly seated with the seat belt secured around you. Inadvertent movement of the Truck and/or Mower components may cause serious injury or death to the operator and passersby. Read the Truck and Auxiliary Engine operator's manuals for proper starting instructions. (STM-16)

6.AUXILIARY ENGINE OPERATION

Power to operate the boom and mower is supplied from the bed mounted auxiliary engine and hydraulic pump. The auxiliary engine uses the same fuel supply as the truck engine. The auxiliary engine ignition switch, throttle control and engine gauges (tachometer, oil pressure, engine temperature) are located in a separate control box mounted in the center of the truck cab.

To start the auxiliary engine, both the Mower Control Switch and the Joystick Master Switch must be in the OFF position. For operator safety, the auxiliary engine will not start with either switch in the ON position. If the auxiliary engine can be started with either the Mower Control Switch or the Joystick Master Switch in the ON position, immediately stop operating the unit and contact Tiger Technical Service for assistance.

IMPORTANT: Make sure the hydraulic tank ball valves are OPEN before starting the auxiliary engine. Starting the auxiliary engine with the valves closed can result in serious system damage. (OPS-TRK-0025)

6.1 Starting Engine:

Press and hold the Murphy switch on the engine console. Start the ignition switch. Continue to press and hold Murphy switch until the engine starts and the oil pressure reaches 50 psi (the red indicator on oil pressure gage goes off). (OPS-TRK-0026)

OPERATION

6.2 Running Engine:

Increase or decrease engine rpm with the throttle button on the auxiliary engine control box. (OPS-TRK-0027)

6.3 Stopping Engine:

Reduce engine speed to idle, run at idle for 30 seconds, then turn engine ignition switch OFF. (OPS-TRK-0028)

6.4 Multi-Alarm Safety Shutdown Control:

The MULTI-ALARM are designed to protect engines against Low Oil Pressure, Low Coolant Level and High Coolant Temperature.

When ignition is first turned "ON" system self-tests for 3 seconds indicated by audio alarm and all lights flashing, followed by alarm with low oil pressure light until engine is started and oil pressure rises.

Should an alarm occur on Low Oil Pressure or High Coolant Temperature the audio will sound with corresponding light for 30 seconds followed by engine shutdown.

On Low Coolant Level, the alarm is delayed 8 seconds to assure accurate sensing followed by 30 seconds alarm with light indication before engine shutdown.

If additional engine run time is required the circuit allows two 30 second restarts followed by 2 minute delay before engine can be restarted. (OPS-TRK-0029)

OPERATION

6.5 Auxiliary Engine Controls and Instrument Panel

- A - Key Switch - Starts and Stops the Auxiliary Engine.
- B - Murphy Switch - Illuminates while plugs are warming engine.
- C - Engine Preheater - Preheats the engine before the engine starts.
- D - Engine Throttle Control - Regulates Auxiliary Engine speed.
- E - Beacon Light Switch - Turns On and Off the warning beacon light.
- F - Circuit Breaker - Breaks the circuit for Throttle.
- G - Engine Coolant Temperature Gauge - Indicates the operating temperature of the auxiliary engine coolant.
- H - Engine Oil Pressure Gauge - Indicates auxiliary engine oil pressure.
- I - Tachometer - Shows engine speed in 100's. For example if at 20, engine speed = 20 x 100 = 2000 RPM.
- J - High Pressure Oil Filter By-Pass Indicator Light - Illuminates when hydraulic filter requires changing.
- K - Hydraulic Oil Temperature Gauge - Indicates hydraulic oil temperature.
- L - Volt Meter - Indicates voltage of battery/charging system.
- M - Wigwag Lights Switch - Turns On and Off the Wigwag Lights.
- N - Rear Strobe Lights Switch - Turns On and Off the Rear Strobe Lights. (OPS-TRK-0030)

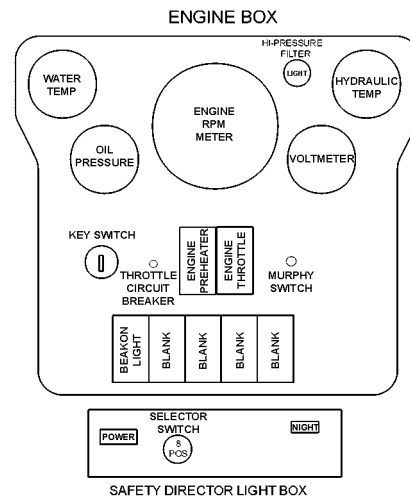
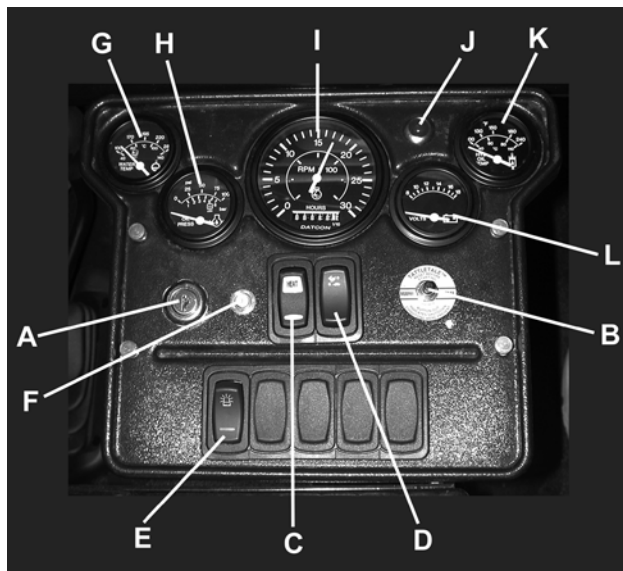

OPERATION

7. SWITCH BOX AND JOYSTICK CONTROL

7.1 Switch Box

The switch box is the smaller of the two boxes mounted in the center of the truck cab. The box houses five controls.

Mower Control Switch - Turns on the mower motor. When the motor is running the Mower Run Indicator Light will be illuminated. The Mower Control Switch must be in the OFF position to start the auxiliary engine.

Joystick Master Switch - Activates the Joystick. Operating any function of the Joystick requires that the Joystick Master Switch be in the ON position. With the Joystick Master Switch in the OFF position all electrical power is disconnected from the Joystick Console. The Joystick Master Switch must be in the OFF position to start the auxiliary engine.

Safety Shield Switch - Opens and closes the retractable door shield on the front of the mower head. Retractable door shield not equipped on all mower heads. Opening the safety shield enables the blades to contact brush and limbs. When mowing at or near the ground, always have the shield in the closed position.

Travel Lock Switch - Locks the Main Boom Cylinder in position during transport. This switch must be in the ON position when the mower is stowed for transport. The auxiliary ignition switch must be in the ON position for the travel lock to be engaged. The Travel Lock Switch must be in the OFF position to allow movement of the boom.

Deck Float Switch - Allows the Deck Roll Cylinder to float so that the mower head follows the contour of uneven terrain. Deck Float is designed for operating flail heads that are running at ground level on a deck roller. (OPS-TRK-0031)

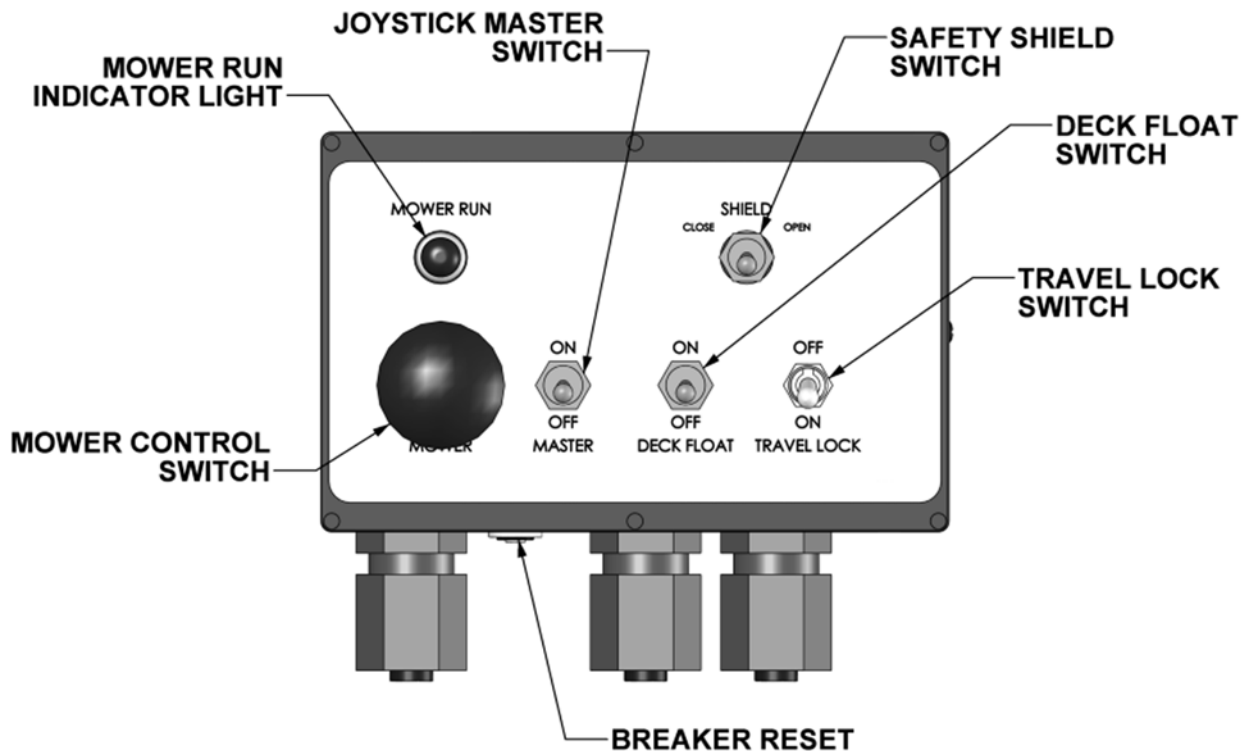

OPERATION

7.2 Joystick

Positioning the boom is performed with electronic valves controlled by the operator using a single joystick. The joystick controls a total of four operations: Main Boom, Secondary Boom, Deck Roll, and Boom Swivel. Using a single joystick, many of the functions can be operated simultaneously such as the main and secondary booms for even greater speed at positioning the mower head.

For safe and efficient boom mower operation, it is critical that the operator be experienced and feel confident in using the joystick control to position the boom. New operator's should be allowed ample time to practice using the joystick to position the boom in an open area before entering the work site. Before attempting to operate this equipment, read these instructions completely. If you have any questions concerning safety of operation, contact your dealer or Tiger Corporation.

Operating any function of the Joystick Console requires that the Joystick Master Switch be in the ON Position. With the Master Switch in the OFF position all electrical power is disconnected from the Joystick Console. Also, right side door must be closed for joystick to operate. With door open, all electronic power is disconnected from the joystick, deck float and deck shield controls.

Each joystick control and responding boom action is covered on the following page. Familiarize yourself with each function then practice in a safe, level area, CLEAR of all people, animals, and any obstructions. As always, use extreme caution when operating this machine.

Practice performing multiple functions simultaneously. With some practice, the boom should become very easy to maneuver and feel almost as it were an extension of your arm. When the Joystick is Released, the valve will automatically return to center, and the boom will be LOCKED at the current position. (OPS-TRK-0032)

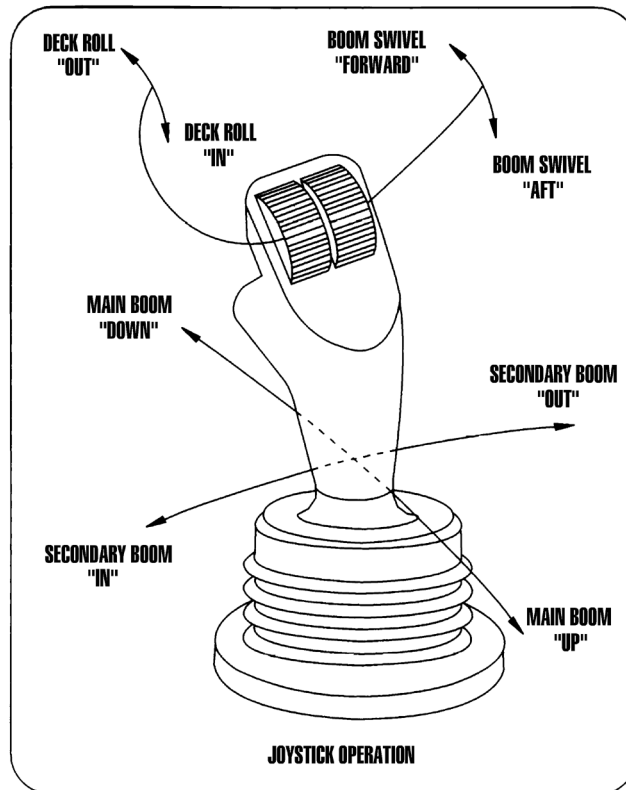

OPERATION

7.3 Joystick Functions

Joystick Forward / Back
Moves Main Boom

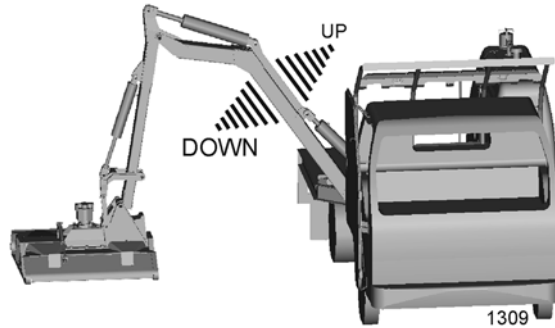

Joystick Left / Right
Moves Secondary Boom

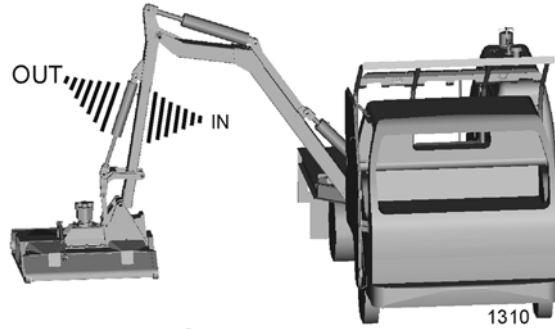

Left Joystick Roller / Rocker
Moves Deck Roll

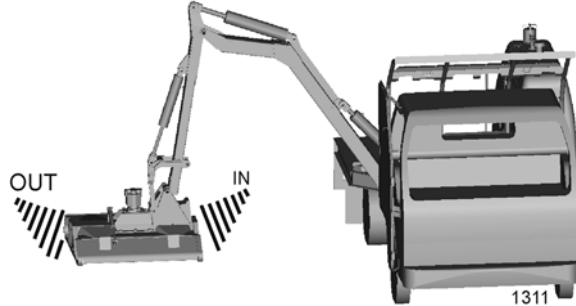

Right Joystick Roller / Rocker
Moves Boom Swivel

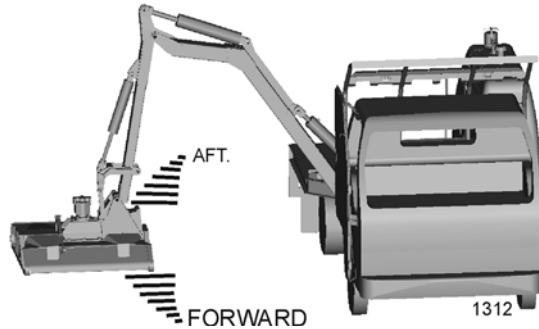

Shield Switch (on Switch Box)
Operates Safety Shield

(OPS-TRK-0033)

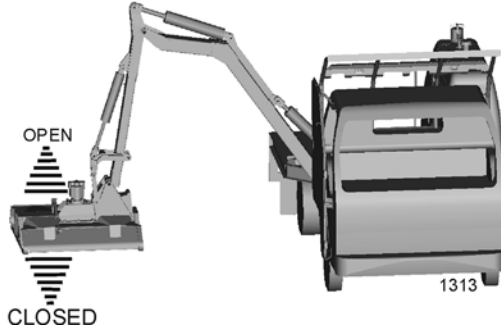

OPERATION

7.4 Lift Valve System

If the joystick control is not operating properly, turn the joystick and mower control switch to the "OFF" position. Install the manual valve handle onto valve and operate the functions individually to stow boom. After boom is stowed in rest, transport the unit to the maintenance facility and contact your Tiger dealer for assistance.

DO NOT attempt to operate the valve manually for mowing operations!

NOTE: Pushing manual valve handles "down" will bring the main boom "down", secondary boom "in", roll deck "in", swivel boom "forward", and "close" deck shield. Pulling manual handles "up" will bring the main boom "up", secondary boom "out", roll deck "out", swivel boom "aft" and "open" deck shield. (OPS-TRK-0034)

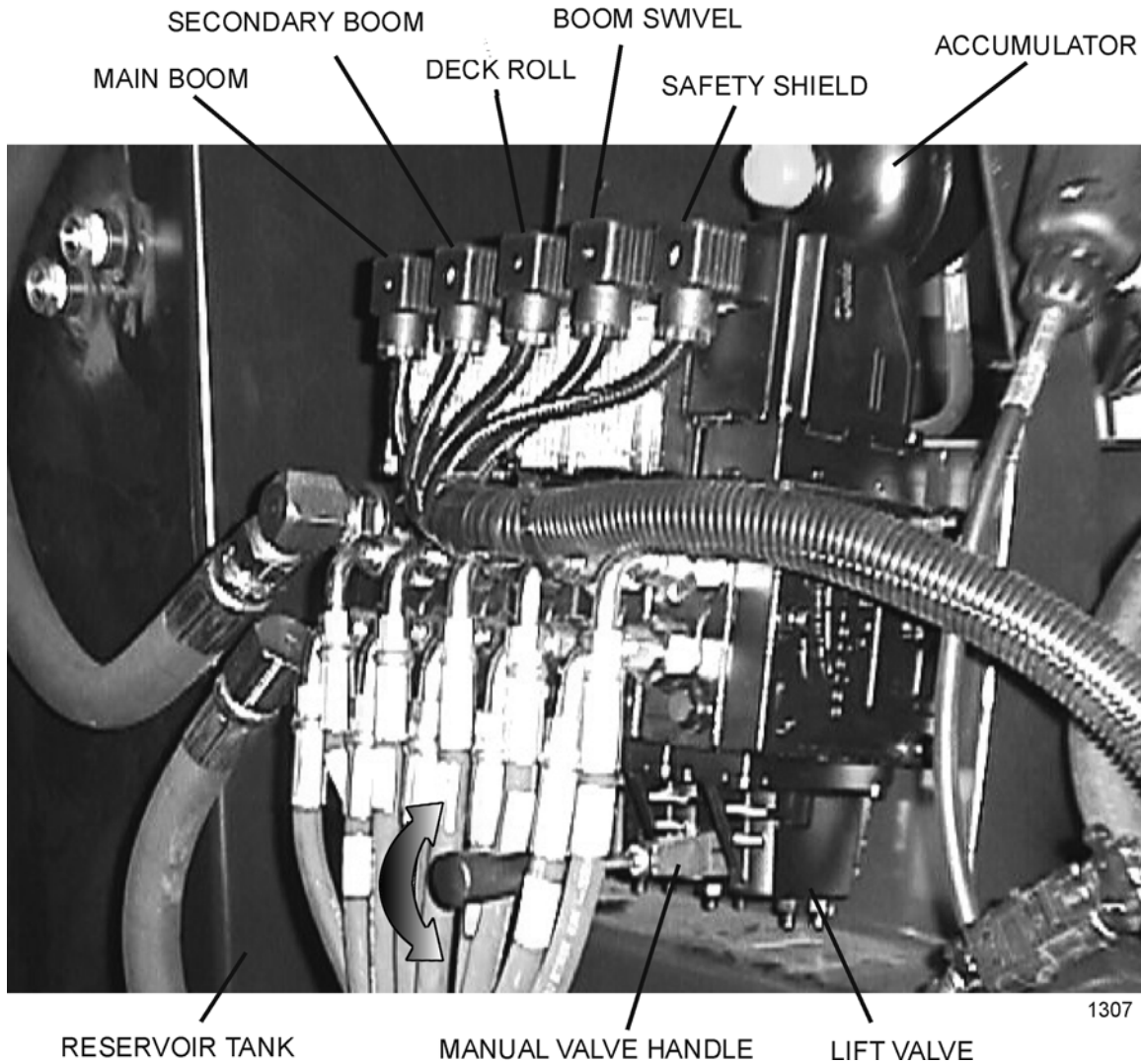

OPERATION

OPERATION

8. GRID HEATER OPERATION



Do not use Eather with Grid Heaters-Improper use of eather and grid heaters may cause an explosion and severe injury.

8.1 B3.3 Series Engines

Cummins recommends the use of a cold start aid device, such as eather or electric intake heaters, below 12°F[-11°C]. The following table summarizes both pre-heat and post heat guidelines for 12V and 24V electric intake heaters. It should be noted that post heat is required only for white smoke control.

Table 1: Pre-heat and Post-heat guidelines for B3.3 engines on 12V and 24V grid heaters.

Pre Heat	Post Heat	Coolant Temperature Below
30 sec	30 sec	-4°F [-20°C]
20 sec	30 sec	5°F [-15°C]
15 sec	30 sec	14°F [-10°C]
10 sec	30 sec	23°F [-5°C]
10 sec	30 sec	32°F [0°C]
10 sec	30 sec	41°F [5°C]
5 sec	15 sec	50°F [10°C]
5 sec	10 sec	53° F [12°C]

1. Prior to cranking the engine the operator pushes the grid heater start button on the dash and hold it "in" for the prescribed preheat time.
2. Operator release the button and turns the key switch to start the engine. (OPS-TRK-0035)

9. MOWER OPERATION

THE OPERATOR MUST COMPLETELY UNDERSTAND HOW TO OPERATE THE TRUCK AND MOWER AND ALL CONTROLS BE FORE ATTEMPTING TO MOW. The operator must read and understand the Safety and Operation Sections of this manual and the truck and auxiliary engine operator's manuals.

Always turn on the truck's flashing lights and light bar when operating the mower to alert drivers and passersby of your presence.

IMPORTANT: Before sure the ball valves on the mower hydraulic tank are **OPEN** before starting the auxiliary engine. Serious damage to the hydraulic system can occur if the valves are not open. (OPS-TRK-0036)

OPERATION



Mow only in conditions where you have clear visibility in daylight or with adequate artificial lighting. Never mow in darkness or foggy conditions where you cannot clearly see at least 300 feet (90 m) in front and to the sides of the tractor and mower. Make sure that you can clearly see and identify passersby, steep slopes, ditches, drop-offs, overhead obstructions, power lines, debris and foreign objects. If you are unable to clearly see these type of items discontinue mowing. (SGM-1)



Do not mow in the reverse direction. Check to make sure there are no persons behind the Truck and Mower before backing up. Mow only at a slow ground speed where you can safely operate and control the Truck and Mower. Never mow an area that you have not inspected and removed debris or foreign material. (STM-32)

OPERATION

9.1 Foreign Debris Hazards / Overhead Obstructions

Before starting any mowing operation, the operator must become familiar with the area to be mowed and any obstacles and hazards contained within to ensure safety to the operator, bystanders, and equipment. Special attention should be paid to foreign debris, overhead obstructions, rough terrain, steep slopes, and passersby and animals in the area.

An area to be cut must first be inspected for objects that could be thrown or that could damage the machine. Walk through the area looking for overgrown fences, boulders and rocks, culverts, stumps or metal objects. Mark the inspected area with flags. If the area is dense and cannot be walked thoroughly it may be necessary to inspect a smaller area as well as possible, then trim away the part that has been inspected and can safely be removed. Walk each new area again and repeat the inspection before cutting more away. Repeat as often as necessary until the area is cleared. It can be damaging and/or dangerous to work the cutter in an area that had not been visually inspected.

Place DANGER signs at least 300 feet beyond the perimeter of the area to be worked, not just 300 feet from where the machine started operating! It is convenient in many cases to work in 300 foot sections. Move the first Danger sign to the beginning of the freshly cleared area, place it, then take the first cutting area flag up to the end of the freshly cleared area 300 feet away. Walk and inspect the next 300 feet and place the second cutting area flag. Pick up the second DANGER sign, and take it a further 300 feet along the road or trail. Note that in many cases the DANGER area will extend in front of and behind the machine as well as along each side. Post signs accordingly. (OPS-TRK-0037)



Extreme care should be taken when operating near loose objects such as gravel, rocks, wire, and other debris. Inspect the area before mowing. Foreign objects should be removed from the site to prevent machine damage and/or bodily injury or even death. Any objects that cannot be removed must be clearly marked and carefully avoided by the operator. Stop mowing immediately if blades strike a foreign object. Repair all damage and make certain rotor or blade carrier is balanced before resuming mowing. (SGM-05)



OPERATION

⚠ WARNING

Many varied objects, such as wire, cable, rope, or chains, can become entangled in the operating parts of the mower head. These items could then swing outside the housing at greater velocities than the blades. Such a situation is extremely hazardous and could result in serious injury or even death. Inspect the cutting area for such objects before mowing. Remove any like object from the site. Never allow the cutting blades to contact such items.

(SGM-06)

⚠ DANGER

Always keep a careful lookout and use extreme care when working around overhead obstructions. Never allow the Mower head or boom within 10 feet of any power line. When working close to overhead power lines consult your electric company for a safe code of operation.

(SBM-7)

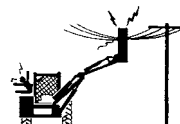

9.2 Bystander / Passersby Precautions

If a bystander comes within 100 yards of the truck while the mower is being operated, stop the mower at once. DO NOT start the mower again until all bystanders are well past the 100 yard distance. (OPS-TRK-0038)

⚠ DANGER

Use extreme caution when raising the Mower head. Stop the Blades from turning when the Mower Head is raised and passersby are within 300 feet. Raising the Mower head exposes the Cutting Blades which creates a potentially serious hazard and can cause serious injury by objects thrown from the Blades or by contact with the Blades. (SBM-2)

⚠ DANGER

Rotary Mowers are capable under adverse conditions of throwing objects for great distances (300 feet or more) and causing serious injury or death. Follow safety messages carefully.

STOP MOWING IF PASSERSBY ARE WITHIN 100 YARDS UNLESS:

Front and Rear Deflectors are installed and in good, working condition;

Mower Head is running close to and parallel to the ground without exposed Blades;

Passersby are outside the existing thrown-object zone;

All areas have been thoroughly inspected and all foreign material such as rocks, cans, glass, and general debris has been removed.

NOTE: Where there are grass and weeds high enough to hide debris that could be struck by the blades, the area should be: inspected and large debris removed, mowed at an intermediate height, inspected closely with any remaining debris being removed, and mowed again at desired final height. (SBM-1)

9.3 Operating Speed and Ground Speed

Ground speed for mowing will depend upon the height, type, and density of vegetation to be cut. For cutting heavy brush and limbs, it is usually best to stop the truck and move the head into the vegetation to be cut. Operate the auxiliary engine at 2400 rpm to maintain mower blade speed for a clean cut. Make sure that the mower has reached full speed before entering that vegetation to be cut. (OPS-TRK-0039)

OPERATION

9.4 Operating the Mower

Once on location, start the auxiliary engine and allow the engine to stabilize and reach a normal operating temperature. Turn the Travel Lock Switch to the OFF position and the Joystick Master Switch to the ON position. Increase the auxiliary engine throttle to the recommended operating speed of 2400 rpm. Using the joystick, remove the mower head from the transport position and position the deck slightly above the material to be cut. DO NOT attempt to start the mower while under a load.

After the first day of operation, all bolts should be checked and tightened securely. This should be done periodically to ensure the bolts do not become loose and cause damage to the truck or mower, or injury to the operator.

To Start the Motor on the Attached Head, pull the red Mower Control Switch knob out completely to the ON position. The Motor will advance to full operating speed within fifteen seconds. The mower will continue to operate while the Mower Control Switch is in the ON position.

To stop the motor on the mower head, maintain the auxiliary engine speed at the normal operating speed (2400 RPM) and push the Mower Control Switch in to the OFF position. The mower head hydraulic circuit is equipped with a brake valve to bring the mower to a complete stop in a short period of time. The brake is automatically activated when the mower control switch is turned to the OFF position. The mower blades will come to a complete stop.

If bystanders approach within 300 feet while mower is in operation turn mower switch "OFF" immediately! After shutdown, never leave the truck or allow bystanders to approach within **300 FEET** of the unit until all motion stops completely. (OPS-TRK-0040)

9.5 Safety Switches

There are three safety switches that will activate the motor brake and stop the mower. These include an operator presence seat switch, a right side door switch, and a boom swing switch. These switches require that the operator be seated in the right side seat, the right side door be closed, and the boom swung clear of the truck bed for the mower to run. (OPS-TRK-0041)

9.6 Mowing at Ground Level

A flail mower deck should be carried so that part of the deck weight is carried by the boom and part carried by the ground roller, when mowing on the ground. When the flail mower is carried this way, the ground roller follows the contour of the ground more easily during mowing operations.

The rotary mower deck should always be carried rather than dragged on the skid shoes when mowing on the ground. Dragging the rotary mower deck increases the side loads on the boom, decreases the horsepower available to the cutter head, and reduces the ability of the accumulator to carry part of the weight of the boom during mowing operations. (OPS-TRK-0042)

OPERATION

9.7 Cutting Brush and Trees

When using the rotary cutting head for trimming trees and shrubs, let the mower saw into them. Do not lower the mower head down directly onto a tree or stump. The mower blades are designed to cut with the end, and misuse can cause damage to the blade and a hazardous situation for the operator. Begin a pass at the top side of the trees and work down with each consecutive pass. When the initial pass has been made, disengage the mower, and return boom to a safe travel position. Return to starting point and make next pass. When cutting trees and shrubs, use a lower speed to allow the blades time to cut as well as mulch the foliage. **DO NOT** use excessive force when positioning cutting head into heavy branches or stumps. Damage to the unit may result. It is best to let the cutter head “eat away” slowly at heavy cutting jobs.

For cutting brush and trees, it is usually best to stop the truck and swivel the boom and mower into foliage. The horizontal positioning action of the boom is designed to position the cutting head and provide a limited pressure relief when excessive pressure is applied to the boom.

The mower will operate more efficiently in tougher conditions and with less power if the blades are kept sharp. If the mower begins to vibrate, stop the unit, check for wire wrapped in the spindle or damaged blades. When replacing blades, replace both blades with new blades to ensure proper balance so the mower will not vibrate. Severe vibration will result if blades with unequal wear are used. (OPS-TRK-0043)

9.8 Boom Rotary Cutter

- The Rotary Cutting Head is rated to cut vegetation up to 6” in diameter.
- Objects tend to be thrown out from under the head in the direction of blade rotation and toward the raised edge of the shroud. Avoid cutting with the head tilted at an angle that objects would be thrown towards the truck operator station.
- When clearing brush and small trees, start at the top of then lower the head down through the brush while sweeping from right to left. This avoids clogging the head with cut and mulched material.
- Open the hydraulically operated door shield to allow blades to reach large diameter vegetation. Operate the mower with the door closed when cutting grass, weeds, and light brush to reduce thrown objects for safer mower operation.

(OPS-TRK-0044)



OPERATION

9.9 Boom Flail Cutter

- The Boom Flail Cutter can be equipped with either grass knives or brush knives. Grass knives are designed for cutting grass only. Brush knives are rated to cut material up to 3" in diameter.
- The Boom Flail cutter is ideal for cutting hard to reach areas where a smooth cut is required.
- Cutting height ranges from 1-6". Cutting height is set by adjusting the height of the rear roller.
- When clearing brush and small trees, start at the top of then lower the head down through the brush while sweeping from right to left. This avoid clogging the head with cut and mulched material.
- Open the retractable hood when cutting large diameter vegetation to allow access to the cutting knives. Close the hood to cut fallen limbs into 3/4" mulch size pieces. (OPS-TRK-0045)

9.10 Clean Cut Saw Blade

- The Clean Cut Saw Blade is rated to cut material up to 6" in diameter.
- Always cut with the boom positioned perpendicular (straight out) from the truck (see diagram). Cutting with the boom swung backward or forward will cause the blade to warp from "raking" through the cut material.
- For maximum blade life, do not allow the blades to contact hard items such as the ground or metal objects. (OPS-TRK-0046)

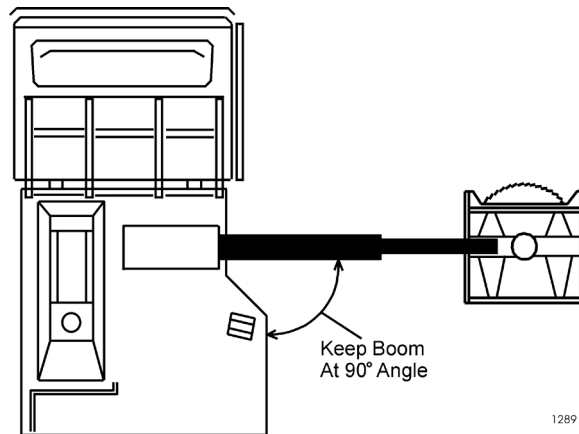

9.11 Ditcher Head

- The ditcher head is designed to dig ditches and clean and reshape existing ditches for water drainage applications.
- The ditcher is designed for either forward or reverse rotation. Forward rotation will deposit the soil away from the truck. Reverse rotation will deposit the soil between the ditcher and the truck. (OPS-TRK-0047)



9.12 Shutting Down the Mower

To shut down the mower, disengage the head motor by pushing in on the red knob of the Mower Control Switch. Maintain the auxiliary engine at operating speed until the mower has come to a complete stop. DO NOT turn the auxiliary engine off before stopping the mower head. Wait for all rotating motion to stop before proceeding to stow the boom and mower in the transport position or exiting the truck cab. (OPS-TRK-0048)

OPERATION

9.13 Returning Mower Head to Transport Position

When preparing to return the boom arm to the boom rest, always shut down the attached head motor and give the blades enough time to come to a complete stop BEFORE placing the boom and head in the transport position.

Placing Boom Arm with 50" Rotary Head In Transport Position

- 1 To place the boom arm in the transport position, first bring the Main Boom to its full height.
- 2 Extend the Secondary Boom approximately half way out and carefully swivel the Main Boom back until the mower head is positioned just over the truck bed. There is a formed transport bracked on the truck bed where the mower head must be stowed for transport.
- 3 Maneuver the boom to place the mower head in the transport bracket. When properly seated, the head will be completely resting on the truck bed and in the bed transport bracket.
- 4 After mower head is stowed, index the Main Boom "down" function for 3-5 seconds minimum.
- 5 Turn travel lock switch to "ON" position and joystick master switch to "OFF" position. Throttle Auxiliary Engine to idle, run at idle for 30 seconds, then turn engine off. The mower and boom are now ready for transport or storage. (OPS-TRK-0049)



Placing Boom Arm with 60" Rotary Head In Transport Position

- 1 To place the boom arm in the transport position, first bring the Main Boom to its full height.
- 2 Roll the mower head out completely to the deck stop.
- 3 Extend the Secondary Boom approximately 90° to the Main Boom and carefully swivel the Main Boom "AFT" until the mower head is positioned just over the truck bed.
- 4 Then lower Main Boom and adjust Secondary Boom to position mower head over stowage bracket. **(CAUTION: Do not move secondary boom in too far or mower head may contact hand rail or engine enclosure).**
- 5 Now lower the Main Boom until the mower head contacts the base plate of the stowage bracket, then slowly extend the Secondary Boom until mower head contacts the vertical retaining bar of the stowage bracket.
- 6 After mower head is stowed, index the Main Boom "DOWN" function for 3-5 seconds minimum.
- 7 Turn travel lock switch to "ON" position and joystick master switch to "OFF" position. Throttle Auxiliary Engine to idle, run at idle for 30 seconds, then turn engine "OFF". The mower and boom are now ready for transport or storage. (OPS-TRK-0050)



OPERATION

Placing Boom Arm with 50" Snow Blower In Transport Position

- 1 To place the boom arm in the transport position, first bring the Main Boom to its full height.
- 2 Roll the snow blower out completely to the deck stop.
- 3 Extend the Secondary Boom approximately 90° to the Main Boom and carefully swivel the Main Boom "AFT" until the snow blower is positioned just over the truck bed.
- 4 Then lower Main Boom and adjust Secondary Boom to position snow blower over stowage bracket.
- 5 Now lower the Main Boom until the snow blower contacts the base plate of the stowage bracket.
- 6 After the snow blower is stowed, index the Main Boom "DOWN" function for 3-5 seconds minimum.
- 7 Turn travel lock switch to "ON" position and joystick master switch to "OFF" position. Throttle Auxiliary Engine to idle, run at idle for 30 seconds, then turn engine "OFF". The mower and boom are now ready for transport or storage. (OPS-TRK-0051)



10. TRUCK BOOM MOWER STORAGE

Properly preparing and storing the mower at the end of the season is critical to maintaining its appearance and to help ensure years of dependable service. The following are suggested storage procedures:

- Thoroughly clean all debris from the truck, boom, and head to prevent damage from rotting vegetation and standing water.
- Lubricate all grease points and fill spindle oil levels according to maintenance lubrication schedule.
- Tighten all bolts and nuts to the proper torque. Ensure pins and other hardware are in place and in good repair.
- Inspect the boom arm and mower head for worn and damaged parts. Perform repairs and make replacements so that the mower will be ready for use at the start of the next season.
- Store the unit in a clean and dry location.
- Use spray touch-up enamel paint where necessary to prevent rust and to maintain the appearance of the mower.
- Refer to the truck and auxiliary engine operator's manuals for preparing the truck and auxiliary engine for storage. (OPS-TRK-0052)



OPERATION

11. TRANSPORTING THE TRUCK BOOM MOWER

Inherent dangers of operating the truck boom unit and the possibility of accidents are not left behind when you finish mowing an area. Therefore, the operator must employ good judgement and safe operation practices when transporting between locations. By using good judgement and following safe transport procedures, the possibility of accidents while moving between locations can be substantially minimized.

Do not transport the truck at speeds above 15 mph when seated at the truck's right side driving position. When transporting the truck between locations, always drive the truck from the left side driving position. Fold back the right side throttle actuator and pedal onto the floor when the truck is being driven from the left side.

Before transporting, ensure the following

- Auxiliary engine is completely shut down.
- Mower head is properly seated in the bed transport bracket.
- Mower Control Switch is in the OFF position
- Joystick Master Switch is in the OFF position.
- Travel Lock is in the ON position. (OPS-TRK-0053)



1288

11.1 Transporting on Public Roadways

The truck is classified as a motor vehicle and is subject to all inspection, license, and insurance regulations for the state that it is operated in. The driver must possess the required license to drive the unit on a public roadway.

OPERATION



Transport the Truck and Mower only at safe speeds. Serious accidents and injuries can result from driving this Truck at unsafe speeds. Become familiar with the driving characteristics of the Truck and how it handles before operating or transporting on streets and highways. Make sure the Truck's steering, brakes, tires, and wheels are in good condition and operate properly. Before transporting the Truck and Mower determine the safe transport speeds for you and the machine. Make sure you abide by the following rules:

8. Test the Truck and Mower at a slow speed and increase the speed slowly. Apply the brakes smoothly to determine the stopping characteristics of the Truck equipped with the Mower. As you increase the speed of the Truck, the stopping distance increases. Determine the maximum safe transport speed. When driving down a hill or on wet, rain slick, snow covered, or icy roads, the braking distance increases: use extreme care and reduce your speed. Do not operate the Truck with weak or faulty brakes.
9. Obey all traffic laws and regulations. Never exceed the posted speed limit. Never exceed warning speed limits for curves and down hill operation.
10. The Truck and Mower have a high center of gravity. Use extreme caution when transporting at highway speeds. Slow down for sharp corners and rough or uneven surfaces to avoid tipping or turning the Truck over.
11. Only transport the Truck at the speeds determined as safe and which allow for proper control of the machine while driving and stopping during an emergency.
12. When operating in traffic, use the Truck's directional indicator or signal lights to indicate your movement. Always use the Truck's flashing signal lights and other equipped warning features to alert motorist of your presence and slow moving speed while mowing. Be Aware of Traffic Around You and Watch Out for the Other Guy. (STM-44)

11.2 Hauling the Truck Boom Unit

Before hauling a loaded unit, **measure the height and width and gross weight of the complete load.** Ensure the load will be within **legal limits for all areas that it will be transported through.**

Load the unit in the center of the bed for an even weight distribution. Position the boom so that the mower head is behind the TruckKat®, then lower the boom until the head rest on bed. Use chains, heavy duty straps, cables, binders or other securing devices to securely tie down both the front and rear of the truck utilizing proper tie down points. Arrange tie-downs to pull downward and against themselves. **CAREFULLY** tension chains using binders to apply maximum tension.

While hauling the truck boom unit, make occasional stops to check that the truck has not moved or shifted and remains secured to the transporting equipment. If during transport a hard braking, sharp turning, or swerving action was performed, stop at the next safe location to inspect the security of the load.

Use extreme care when removing the devices used to secure the load. Tension in chains, straps, binders and other devices have the potential to inflict serious injury if not released properly. (OPS-TRK-0054)

OPERATION

OPERATION

TrucKat®

Operation Section 3-28

MAINTENANCE SECTION

Maintenance Section 4-1

MAINTENANCE

General Instructions

Tiger Mowers are designed for high performance and rugged durability, yet with simplified maintenance. The purpose of this section of the manual is to help the operator in the regular servicing of the mower. Regular maintenance at the intervals mentioned will result in the maximum efficiency and long life of the Tiger Mower.

When you purchase a Tiger Mower you also acquire another valuable asset, Tiger's parts organization. Our rapid and efficient service has guaranteed the customer satisfaction for many years. Tiger parts keep up with the demands for efficiency, safety and endurance expected of the Tiger Mower.

Maintenance Precautions

- Be sure end of grease gun and zerks are clean before using. Debris injected into bearings, etc. with grease will cause immediate damage.
- DO NOT use a power grease gun to lubricate bearings. These require very small and exact amounts of lubrication. Refer to the detailed maintenance section for specific lubrication instructions. DO NOT over-grease bearings.
- Lexan windows should be washed with mild soap or detergent and luke warm water, using a soft clean sponge or soft cloth. DO NOT use abrasive or alkaline cleaners or metal scrapers on lexan windows!
- Be alert to maintenance indicators such as the in-tank filter pressure gauge, hydraulic reservoir sight gauge, etc. Take the required action to correct any problems immediately.
- Release of energy from pressurized systems may cause inadvertent actuation of cylinders, or sudden release of compressed springs. Before disconnecting any hoses relieve pressure by shutting tractor off, setting cutter on ground and actuating lift valve handles.



DO NOT use hands to check for suspected leaks in hydraulic hoses! Hydraulic fluid escaping under pressure can have sufficient force to penetrate skin and cause serious injury. If fluid is injected into skin, it must be surgically removed within a few hours or gangrene may result. Use a small piece of wood or cardboard, not hands, to search for pin hose leaks. Be sure all connections are tight and hoses and lines are not damaged before applying pressure.

Break in Period

In addition to following the break in instructions for your particular tractor, the in-tank hydraulic fluid filter should be replaced after the first 50 hours of service. Thereafter the filter should be replaced every 500 hours, or yearly, whichever comes first.

Re-torque wheel lugs after first five hours of operation and periodically thereafter. See torque specifications listed in the tractor's service manual for your particular model. **Wheel lugs must always be re-torqued whenever a wheel is removed and reinstalled.**



Never work under the Implement, the frame, or any lifted component unless the Implement is securely supported or blocked up to prevent sudden or inadvertent falling which could cause serious injury or even death. (SG-14)



MAINTENANCE



WARNING

Do not modify or alter this Implement. Do not permit anyone to modify or alter this Implement, any of its components or any Implement function. (SG-8)



WARNING

Relieve hydraulic pressure prior to doing any maintenance or repair work on the Implement. Place the Mower Head on the ground or securely supported on blocks or stands, disengage the PTO, and turn off the engine. Push and pull the control Levers or Joystick several times to relieve pressure prior to starting any maintenance or repair work. (SBM-6)



DANGER

Always disconnect the wire leads from the mower pump solenoid before performing service on the Tractor or Mower. Use caution when working on the Tractor or Mower. Tractor engine must be stopped before working on Mower or Tractor. The Mower Blades could inadvertently be turned on without warning and cause immediate dismemberment, injury or death. (SBM-12a)

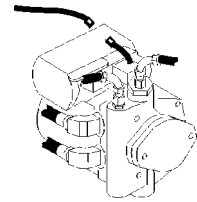

MAINTENANCE

MAINTENANCE

Regular Maintenance

The intervals at which regular servicing should be done are based on hours of operation. Use the auxiliary engine hour meter to determine when regular servicing is required.

Refer to the Detailed Maintenance section for further instructions on greasing. Copy and use the Daily Maintenance sheet located at the end of this section.

Daily or Every 8 Hours

ITEM	SERVICE	COMMENTS
Pivot Points	Lubricate	Inject grease until it appears at end
Hydraulic Fittings	Check for leaks	Tighten when needed. Do Not use hands to check for leaks, see maint. Precautions
Knives	Check	Inspect for missing or damaged knives, change as needed.
Spindle mounting bolts (spindle to deck)	Check	Torque to 331ft. lbs. lubricated Torque to 357ft. lbs. dry
Knife mounting bolts (knife to disk or blade bar)	Check	Pre-lubricate threads, then torque to 800 ft. lbs.
Disk/Blade Bar mounting bolts (disk/blade bar to spindle)	Check	Torque to 184ft. lbs. lubricated Torque to 180ft. lbs. dry
Belts	Check/Adjust	Check if broken, tighten as required
Main Frame and Deck	Check	Retorque bolts to torque specifications in this section
Hydraulic Fluid Level	Check	Add if required per fluid recommendations
Rear Flail Drive(if applicable) Bear Flange and Shaft Coupler	Lubricate	Grease as instructed in detailed maint. section
Cutter Shaft and Ground Roller	Lubricate	Grease as instructed in detailed maint. section

MAINTENANCE

MAINTENANCE

WEEKLY OR EVERY 40 HOURS

ITEM	SERVICE	COMMENTS
Rotary Spindle	Lubricate	Every 40 hours or weekly

WEEKLY OR EVERY 50 HOURS

ITEM	SERVICE	COMMENTS
In Tank Hyd. Fluid Filter (10 micron filter)	Change	Change after first 50 hours only, then every 500 hours or yearly
In-Line High Pressure Filter (10 micron filter)	Change	Change after first 50 hours only, then every 500 hours or yearly

MONTHLY OR EVERY 150 HOURS

ITEM	SERVICE	COMMENTS
Hydraulic Fluid Level	Check	Add as needed
Hyd. Tank Breather	Clean/Check/Replace	Clean or replace Element as required

YEARLY OR EVERY 500 HOURS

ITEM	SERVICE	COMMENTS
Spindle Grease	Change	
Hyd. Tank Fluid	Change	
In Tank Hyd. Fluid Filter (10 micron filter)	Change	
In-Line HP Filter (10 micron filter)	Change or	Change when indicated by restriction indicator.
Hyd. Tank Breather	Change	

MAINTENANCE

MAINTENANCE

TROUBLESHOOTING - GENERAL

SYMPTOMS	CAUSE	REMEDY
Vibration	<ol style="list-style-type: none"> 1. Loose Bolts 2. Cutter assembly Unbalanced 	<ol style="list-style-type: none"> 1. Check all bolts and tighten to recommended torque specs. 2a. Check for damage blades, disc or cutter shaft. Replace if needed. 2b. Check for wire, rope, etc. entangled in the cutter assembly
Mower will not lift	<ol style="list-style-type: none"> 1. Hyd. Fluid Low 2. Leaks in line ROU 3. Faulty relief valve 5. Faulty cylinder 	<ol style="list-style-type: none"> 1. Check and refill Hyd Fluid 2. Tighten or replace fittings and hoses 3. Check pressure in line. Line pressure in Control Valve should be at least 2500 P.S.I. 5. Inspect, repair or replace cylinder
Mower will not start or run	<ol style="list-style-type: none"> 1. Blown fuse 2. Ball valves closed 3. Low oil level 4. Line leak 5. Electronic solenoid faulty 	<ol style="list-style-type: none"> 1. Check fuse between mower switch and ignition/replace 2. Make sure valves are open 3. Check Hyd. tank and fill 4. Check all fittings and lines, re-tighten or replace 5a. Without the tractor running, turn the mower switch to on. A low audible click should be heard if the solenoid is engaging the solenoid spool. If click is not heard, leave switch in on position and with a screwdriver or other steel object, touch the small nut on the end of the solenoid. If the metallic object is not attracted to the nut, check the fuse and wiring for an open circuit. If the object is attracted but no "click" is heard, replace the solenoid. 5b. Remove the four bolts holding the small block to the main block. Lift and remove small block being careful not to damage O-rings/filter. Clean filter and re-install. 5c. Remove large nut on side of large valve block. Remove spring, and use needle nose vise grip to pull spool from block. Check block and spool for contaminates and scratches. Clean parts or replace if scratched.

MAINTENANCE

MAINTENANCE

TROUBLESHOOTING - GENERAL (CONTINUED)

SYMPTOMS	CAUSE	REMEDY
Motor runs but will not cut.	<ol style="list-style-type: none">1. Belts2. Tensioner	<ol style="list-style-type: none">1. Inspect belts and pulleys. Replace belts and repair as needed.2. Adjust tensioner nut flat washer washer is flush with top of guide.
Mower turns slowly or not at all.	<ol style="list-style-type: none">1. Contaminants restricting spool movement in valve body.2. Suction lines obstructed3. Low oil level	<ol style="list-style-type: none">1. Remove large nut on side of large valve block. Remove spring, and use needle nose vise grip to pull spool from block. Check block and spool for contaminants and scratches. Clean parts or replace if scratched.2. Check for kinks or obstruction in suction hose.3. Check Hyd. tank level and fill.
Pump will not work	<ol style="list-style-type: none">1. Excessive wear on internal parts	<ol style="list-style-type: none">1. Disassemble and repair.
Motor will not work	<ol style="list-style-type: none">1. Excessive wear on internal parts	<ol style="list-style-type: none">1. Disassemble and repair.

NOTE: If flow meter is available, check pressure and flow volume for all suspected hydraulic problems.

If the solution to your problem cannot be found in this section, call the Technical Service representative at the number shown on the front cover of this manual.

MAINTENANCE

MAINTENANCE

TROUBLESHOOTING - AUX. ENGINE TROTTLE

Throttle operation not responding to throttle button movement:

Turn ignition switch "OFF", this will prevent any actuator movement or electrical shorts. Follow the steps as outlined below.

ELECTRICAL TEST

Use a 12 volt test light or volt meter and refer to the mower engine wiring schematic for the following tests. A small test probe or needle maybe necessary to insert into the connector pin.

1. Disconnect the gray colored electrical connector from the throttle actuator by compressing the two small release tabs and pull the connector apart.
2. Turn the auxiliary engine ignition switch to the "ON" position.
3. Attach one test lead from the light or meter to a good ground point.
4. Connect the other test lead to pin # 6 (blue wire) in the gray connector on the cable. The test light must be "OFF" or 0 volt meter reading.
5. Push down the throttle switch to decrease engine rpm. The test light must turn "ON" or 12 volt meter reading. Release throttle switch and test light must trun "OFF" or 0 volt meter reading.
6. Move the test lead to pin # 8 (white wire) in the gray connector on the cable. the test light must be "OFF" or 0 volt meter reading.
7. Push down the throttle switch to increase engine rpm. The test light must turn "ON" or 12 volt meter reading. Release throttle switch and test light must trun "OFF" or 0 volt meter reading.
8. Move the test lead to pin # 3 (red wire) in the gray connector on the cable. the test light must be "ON" or 12 volt meter reading.
9. Disconnect the lead from ground point and reconnect the ground lead to pin # 7 (black wire). The test light must be "ON" or 12 volt meter reading.
10. Turn auxiliary engine ignition switch to the "OFF" position. The test light must turn "OFF" or 0 volt meter reading.
11. Remove test light or meter and reconnect the connector ot the throttle actuator. **NOTE:** the connector has one index key on one side and two on the other side, they mate with grooves on the actuator connector. **DO NOT** apply excessive force to the connector.

If the reading specified in step above are obtained but the actuator will not respond, replace the throttle actuator. There maybe other electrical failures if the reading specified above are obtained, consult your dealer or contact Tiger Customer Service. (MNT-C-0001)

MAINTENANCE

TROUBLESHOOTING - MULTI-ALARM

VERIFICATION AND TEST:

Turn ignition switch "ON", alarm will sound with all lights flashing for 30 seconds followed by oil pressure alarm until engine is started. If not started in 30 seconds, cycle ignition to reset the system.

HIGH COOLANT TEMPERATURE AND LOW OIL PRESSURE TEST:

With engine running, short either sensor terminal to ground, alarm will sound with light indication, ground for 30 seconds and engine will shutdown.

LOW COOLANT LEVEL TEST:

With engine running, remove wire from coolant level sensor, after 8 seconds delay alarm will sound with light indication, after 30 seconds engine will shutdown. To restart, cycle ignition, two additional restarts are allowed followed by 2 minutes delay.

DIAGNOSTIC:

1. Make sure all connections are fully mated. Check fuses, if blown, check BLACK wire for short circuit to ground.
2. Verify connector of VIOLET wire is fully mated and supplying 12 volts constant power.
3. Verify WHITE wire for reliable ground (poor ground may cause false alarm). Connect jumper wire between BLACK and BLUE terminals of harness. If engine starts, replace module. If not, check fuel shutoff solenoid.

Constant alarm on low oil pressure / high temperature:

Verify oil and coolant level.

Start engine, disconnect wire from sensor. If alarm cancels, change defective sensor. If alarm persists, check wire for short circuit to ground. No short circuit, change module.

Constant alarm on low coolant level:

Verify coolant level, fluid must cover sensor completely.

Disconnect wire from coolant sensor, and connect to ground. If alarm cancels, remove and clean coolant sensor. **WARNING** - Do not over tighten coolant sensor. If alarm persists, check wire for open circuit (cut or broken wire). No open circuit, change module.

WARNING:

Ignition must be in "OFF" position and VIOLET wire (constant power) connector must be disconnected before installing or removing multi-alarm module. (MNT-C-0002)

MAINTENANCE

TROUBLESHOOTING - HYDRAULICS

SYMPTOM	CAUSE	REMEDY
Hydraulic Reservoir		
Low oil level	A. Improper service intervals	1. Service per maintenance manual
	B. External leaks	1. Repair leaks
Milky or dirty oil	A. Water in oil	1. Drain and replace hydraulic oil
	B. Filter failure	1. Inspect and replace filter if necessary
	C. Metal particles in oil	1. Replace hydraulic oil, find source of metal particles and repair
Discolored oil & has burnt odor	A. Kinked or crushed lines causing overheating	1. Replace lines
	B. Clogged oil cooler	1. Clean Cooler
	C. Incorrect oil viscosity	1. Replace oil per specifications in manual
Hydraulic Filters		
Contaminated hydraulic oil	A. Improper micron rating of filter element	1. Determine micron rating per manual, replace element
	B. Plugged element	1. Replace element
	C. Filter change interval too long	1. Decrease time between filter change
	D. Oil reservoir cap missing or filter element of cap missing	1. Replace cap or filter material in cap
	E. Ruptured element	1. Check for stuck bypass; repair or replace 2. Replace element per manual
	F. No element	1. Install proper element per manual
Bypass indicator always reads "bypass"	A. Fluid Viscosity too high	1. Check recommended viscosity in manual
	B. Broken or weak spring	1. Replace bypass spring
	C. Plugged element	1. Replace element per manual
Bypass indicator always reads filter is clean	A. No element installed	1. Install element per manual
	B. Ruptured element	1. Check for stuck bypass; repair or replace
	C. Failed bypass spring	1. Replace bypass spring
Ruptured element	A. Bypass not installed or stuck closed	1. Check housing for installed bypass 2. Check for broken spring or guide stem; replace bypass
	B. Too high of pressure for	1. Check that element size is per manual
	C. Change interval is too long	1. Decrease time between filter change
Pumps		
Pump makes excessive noise.	A. Air leaks in suction side of pump	1. Install a vacuum gauge in inlet of oil reservoir; if it indicates zero, air leakage may exist; check suction line for leaks
Popping or banging noise when air bubbles enter the suction side (aeration).		2. Replace pump shaft seal 3. Check that hyd oil level is above outle 4. Check pump housing for cracks 5. Check torque of pump housing bolts
The sound of marbles being rattled together is from cavitation.	B. Aeration of fluid in reservoir	1. Return lines terminate above fluid level 2. Check fluid level; too low can cause excessive heat and foaming

MAINTENANCE

TROUBLESHOOTING - HYDRAULICS (CONTINUED)

MAINTENANCE

SYMPTOM	CAUSE	REMEDY
Pumps (Continued)		
	B. Aeration of fluid in reservoir	3. Check fluid for foam by drawing a sample
	C. Plugged reservoir breather cap	1. Remove clean or replace
	D. Fluid viscosity too high	1. Drain reservoir, fill with oil per manual
	E. Worn or stuck pump parts	1. Check for solid contaminants, if found flush system and filter oil at refill
		2. Check torque of pump housing bolts
	F. Improper pump installation	1. Check alignment with drive mechanism
		2. Check rotation
		3. Check pump RPM, operate per manual
		4. Check system relief valve for proper setting
Pump fails to deliver fluid	A. Low oil level in reservoir	1. Check level, fill to middle of sight glass
	B. Pump intake restricted or plugged	1. Check that suction line valve is open
		2. Check for blockage
	C. Air leak in suction line	3. Check for proper suction hose size
	D. Pump shaft turning slowly	1. Repair leaks
		1. Check prime mover's RPM, operate per manual
	E. Oil viscosity too high or low	1. Drain, flush, refill per manual
	F. Pump parts worn or failed	1. Replace failed or worn parts
	G. Dirt or sludge in pump	1. Disassemble and clean pump
		2. Flush system and refill per manual
	H. Incorrect rotation	1. Check rotation of pump and prime mover
Oil leakage around pump	A. Shaft seal worn	1. Remove and replace
	B. Suction or pressure line connections loose or failed	1. Tighten or replace connections
	C. Pump housing bolts loose	1. Disassemble, inspect seals for damage
		2. Retorque bolts per specifications
	D. Cracked housing	1. Check relief valve pressure setting
		2. Replace pump
Low or erratic pressure	A. Cold hydraulic oil	1. Operate machine to raise temperature
	B. Incorrect oil viscosity	1. Drain and refill with oil per manual
	C. Aeration or cavitation	1. See "Excessive Noise" troubleshooting
	D. Excessive pump wear	1. See "Excessive Wear" troubleshooting
	E. Pump speed too slow	1. Check RPM of prime mover and operate per manual
Excessive pump wear	A. Abrasive in hydraulic oil	1. Drain, flush, refill per manual
		2. Replace all filter elements
	B. Water in oil, appears "milky"	1. Drain, flush, refill per manual
		2. Replace all filter elements
	C. System pressure exceeding pump rating	1. Check for possible relief valve malfunction
	D. Incorrect oil viscosity	1. Drain, flush, refill per manual
	E. Pump misalignment	1. Check pump alignment with prime mover
	F. Aeration or cavitation	1. See "Excessive Noise" troubleshooting

MAINTENANCE

TROUBLESHOOTING - HYDRAULICS (CONTINUED)

SYMPTOM	CAUSE	REMEDY
Actuators - Motor		
Excessive Motor Noise	A. Motor/load coupling misaligned	1. Realign motor and coupling
	B. Aeration	1. Check for foaming oil 2. Check fluid level; too low can cause excessive heat and foaming 3. Return lines terminate above fluid level
	C. Cavitation	1. Check make-up check in brake valve 2. Check viscosity of oil, use oil specified 3. Warm system before operating at full RPM 4. Check for restricted inlet 5. Check pump for cavitation
Motor runs excessively hot	D. Worn or failed parts	1. Disassemble, replace parts 2. Replace motor
	A. Inlet oil is hotter than normal	1. Measure oil temp in reservoir; should not exceed 200°F 2. Check oil level in reservoir 3. Check that oil viscosity is per manual 4. If equipped with oil cooler check for obstruction 5. If operating in high ambient environment (100°F +) may have to add cooler if not so equipped
	B. Motor slippage too great	1. Disassemble, inspect, and replace worn or damaged parts
Motor runs in reverse	C. High flow rate over relief valve	1. Mower motor application excessive (ie: repetitive stalling of motor)
	A. Plumbing incorrect from valve	1. Check plumbing and correct
Motor will not turn	A. Mower jammed	1. Shut down machine, clear foliage from mower
	B. Binding at coupler	1. Check for misalignment, retorque bolts
	C. Low operating pressure	1. Check system relief setting in brake valve
	D. Pump not producing proper volume or pressure	1. Refer to "Pump" troubleshooting
	E. Seized motor parts	1. Disassemble, repair or replace parts 2. Replace motor
Actuators - Cylinders		
Split cylinder wall	A. Excessive pressure	1. Excessive relief valve setting, check and correct 2. Misuse resulting in excessive load, see manual for proper operation
Buckled cylinder rod	A. Excessive compressive load	1. Excessive relief valve setting, check and correct 2. Misuse resulting in excessive load, see manual for proper operation
Cyl rod nut pulled from rod	A. Excessive tensile load	1. Excessive relief valve setting, check and correct 2. Misuse resulting in excessive load, see manual for proper operation

TruckKat®

Maintenance Section 4-12

MAINTENANCE

TROUBLESHOOTING - HYDRAULICS (CONTINUED)

SYMPTOM	CAUSE	REMEDY
Actuators - cylinders (Continued)		
Cylinder leaking	A. Loose fitting	1. Check cylinder port fittings, tighten
	B. Leaking at rod	1. Check seal, replace worn seal

LUBRICATION RECOMMENDATIONS





Description	Application	General Specification	Recommended Mobil Lubricant
Mower Hydraulics Cold Temperatures 0° F Start-Up	Reservoir	ISO 46 Anti-Wear-Low Temp	Mobil DTE 15M
Normal Temperatures 10° F Start-Up		JD-20C MF M1135,M1141 FNH M2C134D(FNH201)	Mobilfluid 424
Normal Temperatures 15° F Start Up		ISO 46 Anti-Wear	Mobil DTE 25
High Operating Temp. Above 90° F		ISO 100 Anti-Wear	Mobil DTE 18M
Cutter Shaft & Ground Roller Shaft(Flail)	Grease Gun	Lithium-Complex Extreme Pressure NLGI-ISO 320	Mobilgrease CM-S
Boom Swivel Boom Cylinder Pivots (Rotary & Flail Boom)	Grease Gun	Lithium Complex Extreme pressure NLGI2-ISO 320	Mobilgrease CM-S
Deck Boom Pivot & Deck Stop Adjustment Rotary & Flail)	Grease Gun	Lithium Complex Extreme Pressure NLGI-ISO 320	Mobilgrease CM-S
Deck Spindle(Rotary)	Grease Gun	Tiger Spindle Lubricant part number 06540000	Mobilith SHC 220

MAINTENANCE

MAINTENANCE

MAINTENANCE

Torque for Standard Fasteners

Nominal Dia.	threads per inch	 Grade 2			 Grade 5			 Grade 8			 Grade 9		
		Tightening Torque			Tightening Torque			Tightening Torque			Tightening Torque		
		Lubed	Dry Plated	Dry plain	Lubed	Dry Plated	Dry plain	Lubed	Dry Plated	Dry plain	Lubed	Dry Plated	Dry plain
(in.)		K = 0.15	K = 0.17	K = 0.20	K = 0.15	K = 0.17	K = 0.20	K = 0.15	K = 0.17	K = 0.20	K = 0.15	K = 0.17	K = 0.20

Unified Coarse Thread Series





Nominal Dia. (in.)	Threads per inch	49 in-lbs	59 in-lbs	66 in-lbs	76 in-lbs	86 in-lbs	101 in-lbs	107 in-lbs	122 in-lbs	143 in-lbs	126 in-lbs	143 in-lbs	168 in-lbs
1/4	20	49	59	66	76	86	101	107	122	143	126	143	168
5/16	18	101	122	135	157	178	209	221	251	295	259	294	346
3/8	16	15 ft-lbs	18 ft-lbs	20 ft-lbs	23 ft-lbs	26 ft-lbs	31 ft-lbs	33 ft-lbs	37 ft-lbs	44 ft-lbs	38 ft-lbs	43 ft-lbs	51 ft-lbs
7/16	14	24	29	32	37	42	49	52	59	70	61	70	82
1/2	13	37	44	49	57	64	75	80	90	106	94	106	125
9/16	12	53	63	70	82	92	109	115	130	154	135	153	180
5/8	11	73	87	97	113	128	150	159	180	212	186	211	248
3/4	10	129	155	172	200	227	267	282	320	376	331	375	441
7/8	9	125	150	167	322	365	429	455	515	606	533	604	710
1	8	187	225	250	483	547	644	681	772	909	799	905	1065
1 1/8	7	266	319	354	596	675	794	836	955	1132	988	1132	1341
1 1/4	7	375	450	500	840	952	1121	1171	1363	1545	1363	1545	1830
1 1/2	6	652	783	869	1462	1657	1950	2031	2371	2688	2371	2688	3162

Fine Thread Series

Nominal Dia. (in.)	Threads per inch	56 in-lbs	68 in-lbs	75 in-lbs	87 in-lbs	99 in-lbs	116 in-lbs	123 in-lbs	139 in-lbs	164 in-lbs	144 in-lbs	163 in-lbs	192 in-lbs
1/4	28	56	68	75	87	99	116	123	139	164	144	163	192
5/16	24	112	135	150	174	197	231	245	278	327	287	325	383
3/8	24	17 ft-lbs	20 ft-lbs	23 ft-lbs	26 ft-lbs	30 ft-lbs	35 ft-lbs	37 ft-lbs	42 ft-lbs	49 ft-lbs	43 ft-lbs	49 ft-lbs	58 ft-lbs
7/16	20	27	32	36	41	47	55	58	66	78	68	78	91
1/2	20	41	49	55	64	72	85	90	102	120	105	120	141
9/16	18	59	71	78	91	103	121	128	146	171	151	171	201
5/8	18	82	99	110	127	144	170	180	204	240	211	239	281
3/4	16	144	173	192	223	253	297	315	357	420	369	418	492
7/8	14	138	165	184	355	403	474	502	568	669	588	666	784
1	14	210	252	280	542	614	722	765	867	1020	896	1016	1195
1 1/8	12	298	357	397	668	757	890	1083	1227	1444	1269	1439	1693
1 1/4	12	415	498	553	930	1055	1241	1509	1710	2012	1768	2004	2358
1 1/2	12	734	880	978	1645	1865	2194	2668	3024	3557	3127	3544	4169

Torque values for 1/4 and 5/16-in series are in inch-pounds. All other torque values are in foot-pounds. K = 0.15 for "lubricated" conditions
 Torque values calculated from formula T=KDF, where K = 0.17 for zinc plated and dry conditions D = Nominal Diameter
 K = 0.20 for plain and dry conditions F = Clamp Load

Torque-Tension Relationship for Metric Fasteners

Nominal Dia. (mm)	Pitch (mm)	 Class 4.6			 Class 8.8			 Class 10.9			 Class 12.9	
		Tightening Torque			Tightening Torque			Tightening Torque			Tightening Torque	
		Lubed	Dry Plated	Dry plain	Lubed	Dry Plated	Dry plain	Lubed	Dry Plated	Dry plain	Lubed	Dry plain
		K = 0.15	K = 0.17	K = 0.20	K = 0.15	K = 0.17	K = 0.20	K = 0.15	K = 0.17	K = 0.20	K = 0.15	K = 0.20
		(ft-lbs)	(ft-lbs)	(ft-lbs)	(ft-lbs)	(ft-lbs)	(ft-lbs)	(ft-lbs)	(ft-lbs)	(ft-lbs)	(ft-lbs)	(ft-lbs)
3	0.5	0.28	0.32	0.38	0.73	0.82	0.97	1.0	1.2	1.4	1.2	1.6
3.5	0.6	0.44	0.50	0.59	1.1	1.3	1.5	1.6	1.9	2.2	1.9	2.5
4	0.7	0.66	0.74	0.87	1.7	1.9	2.3	2.4	2.7	3.2	2.8	3.8
5	0.8	1.3	1.5	1.8	3.4	3.9	4.5	4.9	5.5	6.5	5.7	7.6
6	1	2.3	2.6	3.0	5.8	6.6	7.7	8.3	9.4	11	9.7	13
6	1.25	2.1	2.3	2.7	5.3	6.0	7.0	7.6	8.6	10	8.8	12
7	1	3.8	4.3	5.0	9.7	11	13	14	16	19	16	22
8	1	5.9	6.6	7.8	15	17	20	22	24	29	25	34
8	1.25	5.5	6.2	7.3	14	16	19	20	23	27	24	31
10	1.25	11	13	15	29	33	39	42	48	56	49	66
10	1.5	11	12	14	28	32	37	40	45	53	47	62
12	1.25	21	23	28	53	60	71	76	86	101	89	119
12	1.5	20	22	26	51	58	68	73	82	97	85	113
12	1.75	19	21	25	49	55	65	70	79	93	81	108
14	1.25	26	29	34	66	75	89	95	108	127	111	148
14	1.5	28	32	37	72	82	96	103	117	138	121	161
14	2	30	34	40	78	88	104	111	126	148	130	173
16	1.5	50	57	67	129	146	171	184	208	245	215	287
16	2	47	53	62	121	137	161	173	196	230	202	269
18	1.5	73	82	97	187	212	249	268	303	357	313	417
18	2.5	65	73	86	167	189	222	239	270	318	279	372
20	2.5	91	104	122	236	267	314	337	382	449	394	525

Clamp load calculated as 75% of the proof load for specified bolts. K = 0.15 for "lubricated" conditions D = Nominal Diameter
 All torque values are listed in foot-pounds K = 0.17 for zinc plated, dry conditions F = Clamp Load
 Torque values calculated from formula T=KDF, where K = 0.20 for plain and dry conditions

MAINTENANCE

POLYCARBONATE CARE & MAINTENANCE

The propriety UV and Abrasion Resistant Surface coating on SHIELDS SUPERCOATED polycarbonate significantly improves performance. Periodic cleaning using proper procedures and compatible cleaners are recommended to prolong service life. Tiger Corp. polycarbonate is SUPERCOATED on both sides.

CLEANING THE SUPERCOAT HARD-COAT

1. Wash with a mild solution of soap or detergent and lukewarm water.
2. Using a soft cloth or sponge, gently wash the sheet to loosen dirt and grime and rinse well with clean water.
3. To prevent water spotting, thoroughly dry with chamois or cellulose sponge.
4. Avoid the use of abrasive cleaners, squeegees and/or other cleaning implements that may mar or gouge the coating.

CLEANING AGENTS WHICH HAVE BEEN FOUND TO BE COMPATIBLE UNDER LABORATORY CONDITIONS:

Aqueous Solutions of Soaps and Detergents

Windex(1)	Top Job(2)	Joy(2)	Mr Clean(2)
Fantastik(3)	Formula 409(4)	Sumalight D12	Brucodecid

Organic Solvents

Butyl Cellosolve	Kerosene	Hexel, F.O. 554	Naphtha(VM&P grade)
Neleco-Placer	Turco 5042		

Alcohols

Methanol	Isopropyl
----------	-----------

All residual organic solvents should be removed with a secondary rinse.

GRAFFITI REMOVAL

Butyl cellosolve (for removal of paints, marking pen inks, lipstick, etc.) The use of masking tape, adhesive tape or lint removal tools work well for lifting off old weathered paints.

To remove labels, stickers, etc., the use of kerosene or VM&P naphtha are generally effective. When the solvent will not penetrate sticker material, apply heat (hair dryer) to soften the adhesive and promote removal.

IMPORTANT: If a material is found to be incompatible in a short-term test, it will usually be found to be incompatible in the field. The converse, however, is not always true. Favorable performance is no guarantee that actual end-use conditions have been duplicated. Therefore, these results should be used as a guide only and it is recommended that the user test the products under actual end-use conditions.

MAINTENANCE

MAINTENANCE

RECOMMENDED FILLING INSTRUCTIONS FOR HYDRAULIC RESERVOIRS

When filling or checking the oil level, the unit should be parked on a level surface., shut "OFF", and allow sufficient time to cool to ambient temperature. Use caution when removing the pressurized breather. Do not place face over opening when removing breather.

If your reservoir has two sight glasses: The reservoir should be filled to the top of the lower sight glass on the side of the tank. Do not over-fill. The reservoir has been over-filled when oil is visible in the upper sight glass. If tank has too much oil, the excess may be expelled through the pressurized breather.

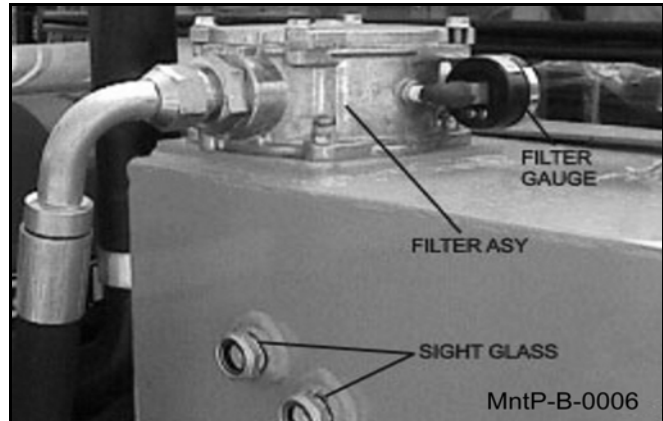

DETAILED MAINTENANCE

REPLACING IN-TANK HYDRAULIC FILTER:

Loosen the four bolts on the top cover of the filter housing. Turn cover counter-clockwise until cover is free. Remove and replace filter. Replace top cover and cover bolts in opposite order as removed.

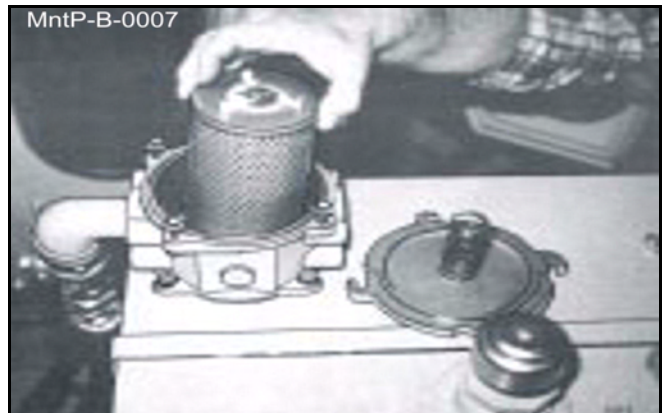

MAINTENANCE

DETAILED MAINTENANCE

REPLACING HIGH PRESSURE HYDRAULIC FILTER ELEMENT:

Assure system has been shut down and de-pressurized. Locate High Pressure Filter housing. Confirm that the element that is about to be installed matches the element p/n on the filter model tag. Example: V3.0510-06 (world line 100, HD049 model) Locate the bottom of the High Pressure Bowl, and use the appropriate spanner wrench-or-ratchet and turning in a counterclockwise rotation, (looking at the bottom of the bowl) remove the bowl from the head, The first couple rotations will seem tight as the o-ring passes the sealing flats.

Once the o-ring has cleared the sealing flats the bowl should spin freely. Taking care not to drop the bowl, finish removing the bowl from the head. **WARNING:** bowl will be full of oil! Pour the oil from the bowl into a container, this oil should be considered contaminated due to the flow direction through the element is outside-in. Clean the inside of the bowl if "dirt" is present. Remove the old element from the filter head by pulling with a rotation motion. Dispose of the used element properly. Remove the new element from the packaging. Using your finger, dab and lubricate the o-ring in the top of the new element. Install the new element into and on the mounting boss within the head; assure that the element is fully seated on the boss. Clean and inspect the o-ring that is affixed in the bowl, lubricate with oil. Using a clockwise rotation, screw the bowl back into the head, assuring that the bowl has not been cross threaded into the head. Continue "tighten" the bowl into the head, using the spanner wrench-or-ratchet, the rotation of the bowl will become tighter once the o-ring engages the sealing flats. Once the bowl has bottomed out, "back-off" the bowl by 1/6 turn, this assures that the o-ring is seated properly within the sealing flats. Element change out and re-assembly is now complete. Start the machine and inspect the filter area checking that there is no oil leaking from the filter assembly. This is first to be done at 50 hours of operation, then yearly (500 hours) or when indicated by restriction indicator.

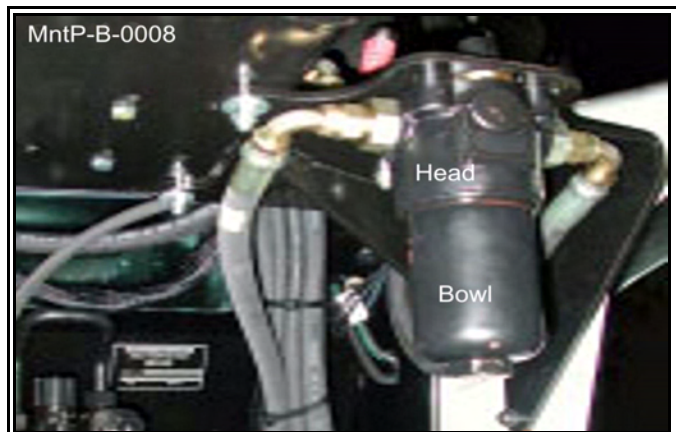

GREASING CUTTER SHAFT-FLAIL MOWERS

Locate grease zerks on each end of cutter shaft(s), these are located on the bearing cover. Normal conditions require one or two pumps in each bearing, using Lithium-Complex Extreme Pressure grease confirming to NLGI2-ISO 320 specifications. This is to be done with a standard grease gun daily or at **8 hour intervals**. **CAUTION: Over greasing may cause premature seal failure.**

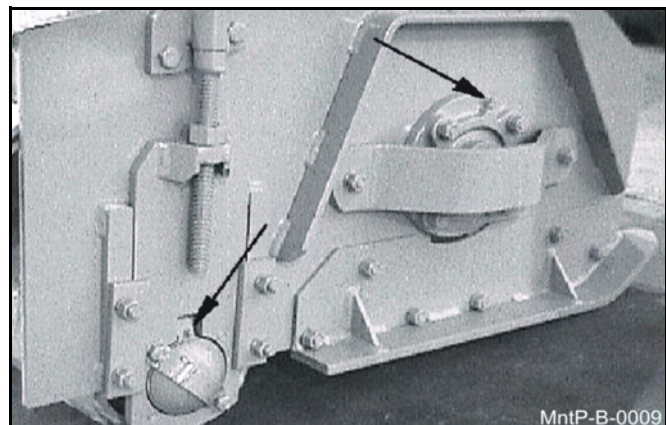

MAINTENANCE

MAINTENANCE

MAINTENANCE

GREASING GROUND ROLLER SHAFT-FLAIL

Locate grease zerks on each end of roller tube at lower end of head. Normal conditions require one or two pumps in each bearing, using Lithium-Complex Extreme Pressure grease conforming to NLGI2-ISO 320 specifications. This is to be done with a standard grease gun daily or at **8 hour intervals**. **CAUTION: Over greasing may cause premature seal failure.**



ADJUSTING/CHECKING BELT TENSION

To adjust belt tension or replace belts on flail cutter head, remove four bolts that secure the belt cover and remove cover. The hex nuts shown below can be adjusted to increase/decrease the belt tension as needed. (NOTE: Location of adjustment nuts may vary on flail cutter heads.) **Be sure to replace the belt cover BEFORE operating mower!**

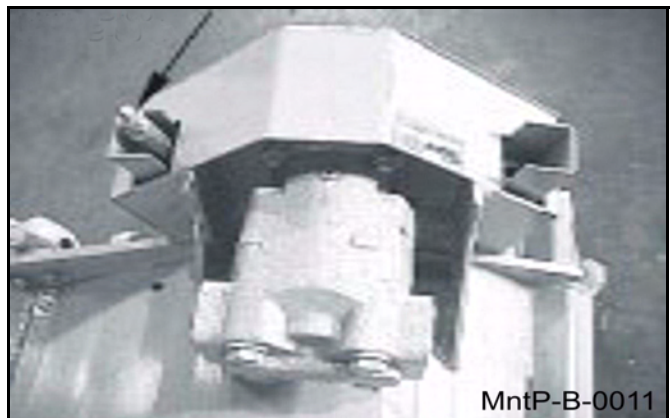

TIGHTENING KNIFE BOLTS AND DISK BOLTS:

After every 8 hours of operation or daily, the Knife Bolts and Disk Bolts should be tightened as follows:

Knife mounting bolts torque to 800 oiled ft. lbs.

Disk mounting bolts (6ea.) torque to 204 dry or 180 oiled ft. lbs.

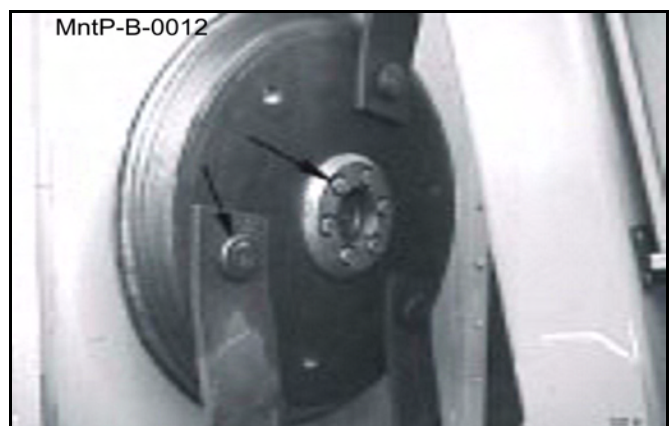

MAINTENANCE

GREASING POINTS ON BOOM AND PIVOT

Locate grease zerks on deck pivot assembly, on the deck end of secondary boom, at main/secondary boom joint, and at swivel end of main boom. Inject Lithium-Complex Extreme Pressure grease conforming to NLGI2 -ISO 320 specifications until grease begins to protrude from ends.

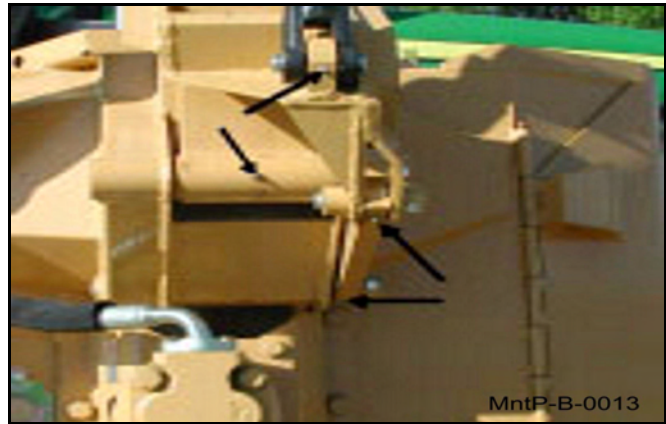

DECK STOP ADJUSTMENT

On boom flail, loosen locking nut. Turn adjustment bolt in, and run deck cylinder out to full extension. Adjust bolt out until the head just touches the boom, and tighten lock nut. **NOTE: Bolt should not hit boom before cylinder reaches full travel.**



GREASING SPINDLE

Locate grease fitting on inside of deck housing. Inject Tiger Spindle Lubricant, part number 06540000 into spindle housing. Fill with lubricant until lubricant weeps out of top spindle seal. Lubricate spindle weekly or every 40 hours of use.



MAINTENANCE

MAINTENANCE

TIGHTENING SPINDLE BOLTS

The spindle mounting bolts should be checked and retorqued daily or every 8 hours of service. Torque the (6) bolts shown below to 357 dry or 315 ft. lbs. lubricated.

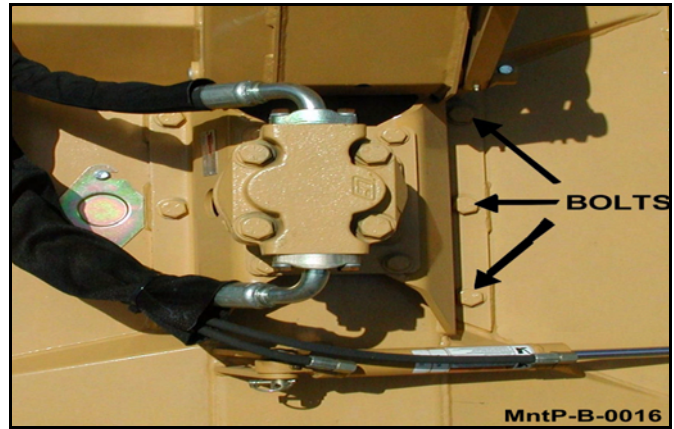

GREASING PUMP DRIVE SHAFT COUPLER

With engine stopped, ensure drive shaft alignment by grasping coupler and sliding back and forth. Coupler should slide freely with approximately 1/8" of end play. If coupler does not slide freely, inspect for loose pump mount bolts, or damaged or loose crank shaft adapter. Inject Lithium-Complex Extreme Pressure grease conforming to NLG12-ISO 320 specifications into coupler until grease begins to protrude from ends. Grease daily or every 8 hours. Do not over grease.



GREASING THE BOOM SWIVEL

Locate the zerks on the main swivel boss (if applicable), main boom pivot boss (if applicable) and on both ends of the boom swivel cylinder. Inject Lithium-Complex Extreme Pressure grease conforming to NLG12-ISO 320 specification until grease begins to protrude from ends.

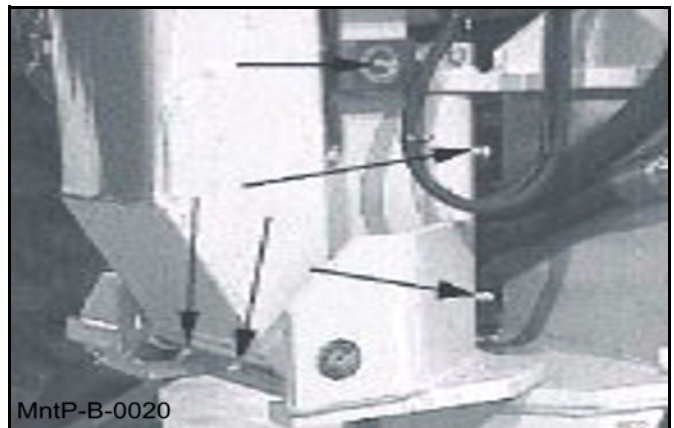

MAINTENANCE

MAINTENANCE

GREASING BOOM CYLINDER(S) PIVOT POINTS

Locate the zerk on the butt end tang of cylinder and on rod end tang. Inject Lithium-Complex Extreme Pressure grease confirming to NLGI2- ISO 320 specifications until grease begins to protrude from ends. This procedure is to be used on the main boom cylinder, secondary boom cylinder, deck pivot, and swivel cylinders daily or at 8 hour intervals.

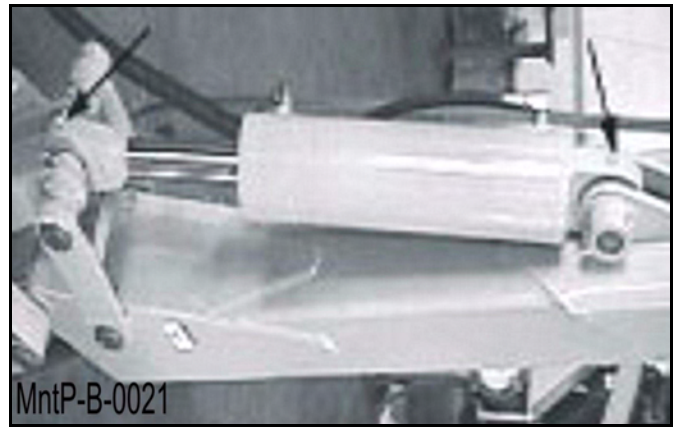

BALL VALVES

The ball valve at the hydraulic reservoir may need to be closed during certain maintenance or repair procedures. **THE BALL VALVES MUST BE OPEN (handle parallel with valve) WHEN TRACTOR IS RE-STARTED OR PUMP IS COU PLED TO MOTOR OR P.T.O.!** Failure to do so will result in component failure!

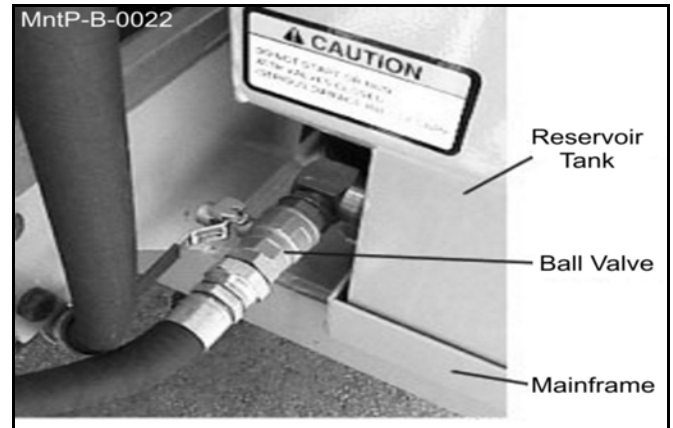

MAINTENANCE

MAINTENANCE

Blades

Check the Blades for cracks and wear and Blade Bolts for tightness, daily. Blades should be replaced when they are worn excessively, bent, deformed, or out of balance.

CAUTION

Blades should always be replaced in pairs. Blades of different weights can cause serious imbalance and damage to the machine and personnel. When replacing blades, take care to replace the blade bolts, nuts, and washers.



Important

Make sure the mower blades are turning clockwise when looking down from the top of the mower. Follow the color coding on the hydraulic hoses and fittings to make sure the motor and hydraulics hoses are assembled properly. Connect the red hose connection only to red fitting. Connect the blue hose connection only to the blue fitting. The blade rotation on the leading edge of the mower should discharge the cut material away from the tractor and operator.

WARNING

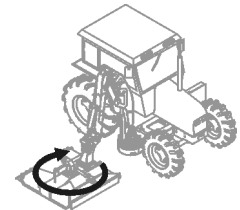
If the leading edge of the mower blades are rotating backwards they can discharge material toward the operator. If this occurs discontinue mowing immediately and reverse the direction of the motor rotation by correctly installing the motor pressure and return hoses. Contact your dealer or Alamo Industrial for specific information on the hose routing.

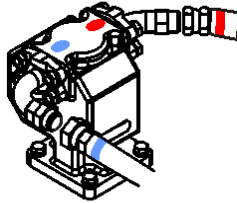

WARNING	ADVERTENCIA
TO AVOID SERIOUS INJURY AND DEATH FROM THROWN OBJECTS: <ul style="list-style-type: none">• MAKE CERTAIN blades rotate the correct direction.	PARA EVITAR LESION SERIA O MUERTE POR OBJETOS LANZADOS: <ul style="list-style-type: none">• ASEGURE que las cuchillas giran en la dirección correcta.
BLADE ROTATION  ROTACIÓN DE CUCHILLAS	
 Return Retorno BLUE	 Pressure Presión RED
	

D619

MAINTENANCE

ROTARY KNIFE REPLACEMENT

1. Be sure you have a complete matching set of new knives for replacement.
2. Remove knives and inspect holes for damage. Also watch for cracks in the disk (if applicable) around the holes.
3. Lube threads with anti-seize. Install bolts through knife and disk from bottom side of disk/blade bar. Install new self-locking nuts and torque them to 800 ft. lbs.
4. The knives should swing freely to absorb shocks from impact when striking objects.



WHEN CUTTING HEAVY BRUSH, KNIFE BOLTS SHOULD BE INSPECTED HOURLY AND RETORQUED TO 1070 DRY OR 800 OILED FT. LBS.

REPLACEMENT OF ROTARY DISK/BLADE BAR



Failure to follow the following warnings and instructions may result in serious injury or damage to the equipment or property!

1. The bolts that attach the disk to the spindle must be grade 8. These 5/8 inch bolts are to be torqued to 204 dry or 184 oiled ft. lbs.
2. A thread locking agent may be applied to threads of all mounting bolts before they are installed.
3. **Disks must be inspected daily for hairline cracks between spindle mounting bolts or around the knife mounting bolts. These cracks indicate metal fatigue caused by severe abuse. If cracks are present the disk must be replaced.**
4. Inspect the disk mounting bolts daily when checking tightness of knife mounting bolts. If a disk mounting bolt is loose, it must be removed, threads cleaned, fresh thread locking agent applied, and tightened to proper torque value.
5. If a knife mounting bolt is loose, the self locking nut must be replaced as a safety precaution. Lubricate threads with anti-seize. Install bolts through knife and disk/blade bar from bottom side. Install self locking nuts and torque them to 800 ft. lbs.

MAINTENANCE

Flail Blades Inspection



Inspect the Blades daily for ab normal wear. REPLACE ALL BLADES on the carrier IMMEDIATELY if any blades have:

- Become bent or deformed from its original shape, or
- Wear inside the blade bolt hole, or
- Any cracks are visible, or
- Deep gouges in the blade's surface are present, or
- Gouges or chipped areas in the cutting edge are larger than 1/4"(8mm), or
- The material on the leading edge has been worn away by more than 1/4"(8mm)

DO NOT straighten, sharpen, weld or hard-face blades

Failure to replace worn or damaged blades may lead to catastrophic failure of the blades and ejection of the broken part with tremendous force which may cause serious bodily injury or death.

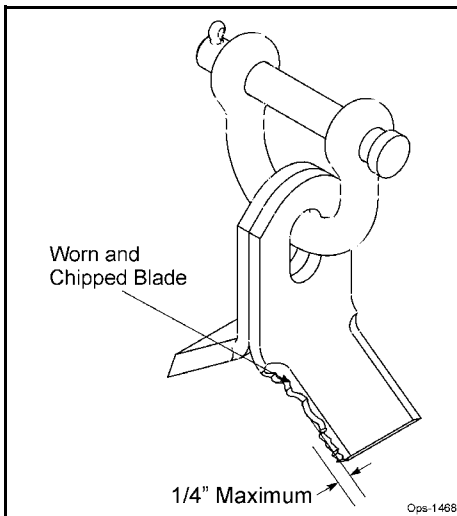

Always replace blades in sets

- Blades that are damaged may indicate severe service or abuse. If one blade is worn or damaged other blades on the same shaft will have been subjected to the same severe service or abuse.
- The Flail rotor turns at speeds exceeding 2000 RPM and is dynamically balanced at the factory. Differences in blade weight between used blades with loss of material from gouges or wear as compared to new blades can cause severe vibration and damage to the Flail rotor. Always replace blades as complete sets.

Important

Use only genuine Alamo Industrial replacement blades and fasteners. Other blades and fasteners may not meet the Alamo Industrial requirements and could fail during operation resulting in part being thrown out from under the mower.



Never attempt to sharpen blades. OPS-U-0044

MAINTENANCE

Blade Pins and D-Ring Inspection

Blade Pins and D-Rings daily for wear or damage as follows:



Inspect the Blade pins and D-Rings daily for abnormal wear. Make sure the cotter pins are in place and properly spread. REPLACE BLADE Pins and D-Rings IMMEDIATELY if they have:

- Visible cracks or
- If a Pin or D-Ring has visible worn areas, or
- If a Pin or D-Ring has gouges or chipped areas

Failure to replace abnormally worn pins or D-Rings may lead to catastrophic failure and ejection of the broken part which may cause serious bodily injury or death.

Always replace the pins and D-Rings whenever excessive wear is noticed.

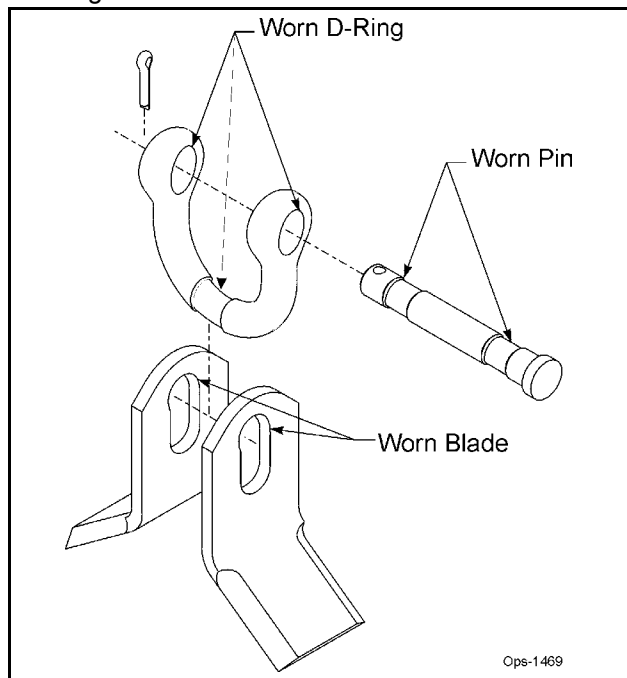

Important

If the cotter pins are broken by contact with other flail blades, remove the pin and reverse the direction the pin is inserted through the D-Ring so that the cotter pin is on the opposite side of the D-Ring. This will prevent the next set of blades from swinging back and hitting the cotter pin. OPS-U-0045

MAINTENANCE

Flail Axe Blades Inspection



Inspect the Blades daily for ab normal wear. REPLACE ALL BLADES on the carrier IMMEDIATELY if any blades have:

- Become bent or deformed from its original shape, or
- Oval shape wear inside the blade bolt hole, or
- Any cracks are visible, or
- Deep gouges in the blade's surface are present, or
- Gouges or chipped areas in the cutting edge are larger than 1/4"(8mm), or
- The material on the leading edge has been worn away by more than 1/4"(8mm)

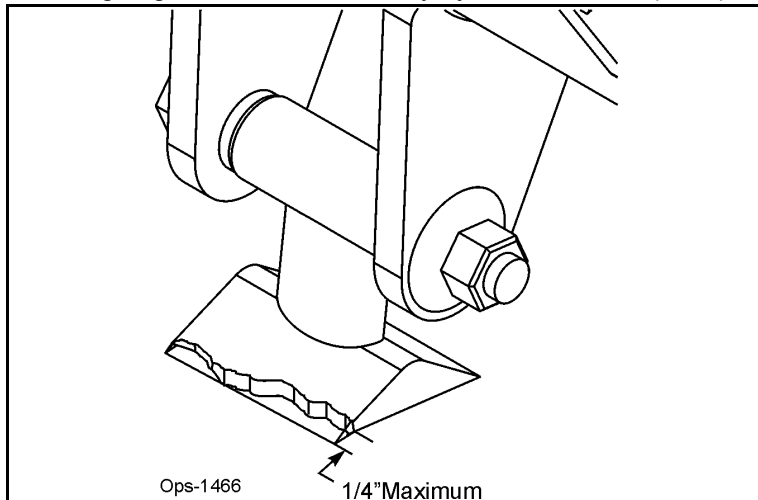

Failure to replace worn or damaged blades may lead to catastrophic failure of the blades and ejection of the broken part with tremendous force which may cause serious bodily injury or death.

Always replace blades in sets

- Blades that are damaged may indicate severe service or abuse. If one blade is worn or damaged other blades on the same shaft will have been subjected to the same severe service or abuse.
- The Flail Axe rotor turns at speeds exceeding 2000 RPM and is dynamically balanced at the factory. Differences in blade weight between used blades with loss of material from gouges or wear as compared to new blades can cause severe vibration and damage to the Flail Axe rotor. Always replace blades as complete sets.

Important

Use only genuine Alamo Industrial replacement blades, blade bolts and fasteners. Other blades and bolts may not meet the requirements of Alamo Industrial and fail during operation resulting in part failing and being thrown out from under the mower.



Never attempt to sharpen blades. **OPS-U-0042**

MAINTENANCE

Flail Axe Blade Bolt Inspection

Inspect Blade Bolts daily for wear or damage as follows:



Inspect the Blade Bolt daily for abnormal wear. REPLACE ALL BLADE BOLTS on the carrier IMMEDIATELY if any bolts have:

- Visible cracks or
- If the blade bolt is worn or any recessed area is visible on the bolt, or
- If Blade Bolt has gouges or chipped areas. or
- If Bushing fits loose in the Rotor Shaft.

Failure to replace abnormally worn bolts or bushings may lead to catastrophic failure of the blades and ejection of the broken part which may cause serious bodily injury or death.

Always replace Blade Bolts with new bolts and new bushings whenever replacing the Blades. To tighten bolts and nuts, first apply thread lock to nut. Make sure to tighten bolts and nuts just enough to allow the blades to swing freely, and not bend the cuttershaft lugs. If cuttershaft lugs are bent together because of over tightening the blades will not swing freely. OPS-U-0043

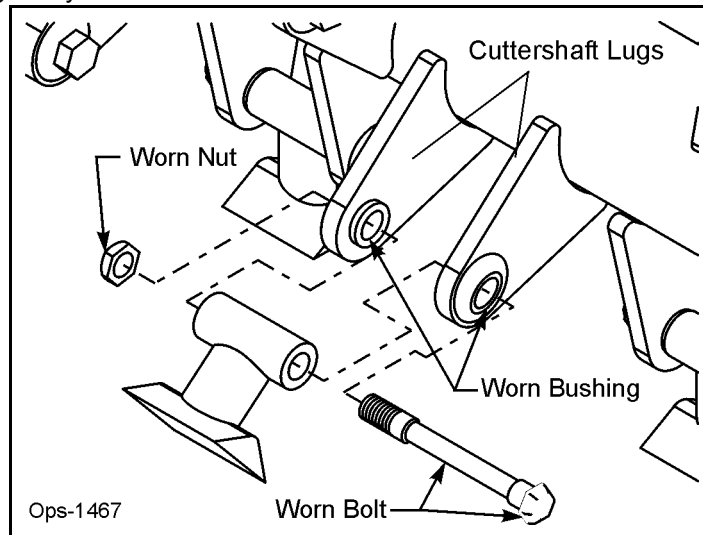

MAINTENANCE

50" FLAIL KNIFE BLADE REPLACEMENT

1. If knives are damaged or badly worn, they will need to be replaced as a set. Replacing a single knife can cause severe vibration and possible damage to the mower. The knife should not be welded on for any reason.
2. Always replace the knife bolts when replacing the knives. DO NOT REUSE THE KNIFE BOLTS OR NUTS.
3. Assemble knives, bushings, bolts and nuts as shown in part section of the manual.
4. Install the locking hex nut so that the flat face of the nut is towards the knife.
5. Apply loctite "271" or equivalent to threads.
6. Torque nut to 50 ft. lbs. Knife must swing freely.



DO NOT re-use the locking hex nuts for mounting the knives. If hex nut becomes loose, or required removal for knife replacement or any other reason, they must be discarded and replaced with new nuts.

63" BOOM FLAIL KNIFE REPLACEMENT

1. If knives are damaged or badly worn, they will need to be replaced as a set. Replacing a single knife can cause severe vibration and possible damage to the mower.
2. Assemble knives, clevis, bolts and nuts as shown in part section of manual.
3. Install locking hex nut so that the flat face of nut is towards the knife.
4. Apply loctite "271" or equivalent to threads.
5. Torque nut to 35 FT. LBS. Knife must swing freely.



DO NOT re-use the locking hex nuts for mounting the knives. If hex nut become loose, or require removal for knife replacement or any other reason, they must be discarded and replaced with new nuts.



Knives should not be welded on for any reason.

HEAVY DUTY SPINDLE ASSEMBLY INSTALLATION AND BEARING ADJUSTMENT

WARNING! A press **MUST** be used to install bearing cups, bearing cones, and seals. DO NOT use a hammer to install races, bearings, or seals. The parts of assembly may be damaged.

NOTE: The grease zerk and gussets are located on the top side of the spindle housing. Be sure the spindle is assembled correctly.

Be sure to wear eye protection and other protective equipment as needed when working on spindle assembly.

MAINTENANCE

MAINTENANCE

THE SPINDLE ASSEMBLY

See the diagram below for identification of spindle parts, while servicing.

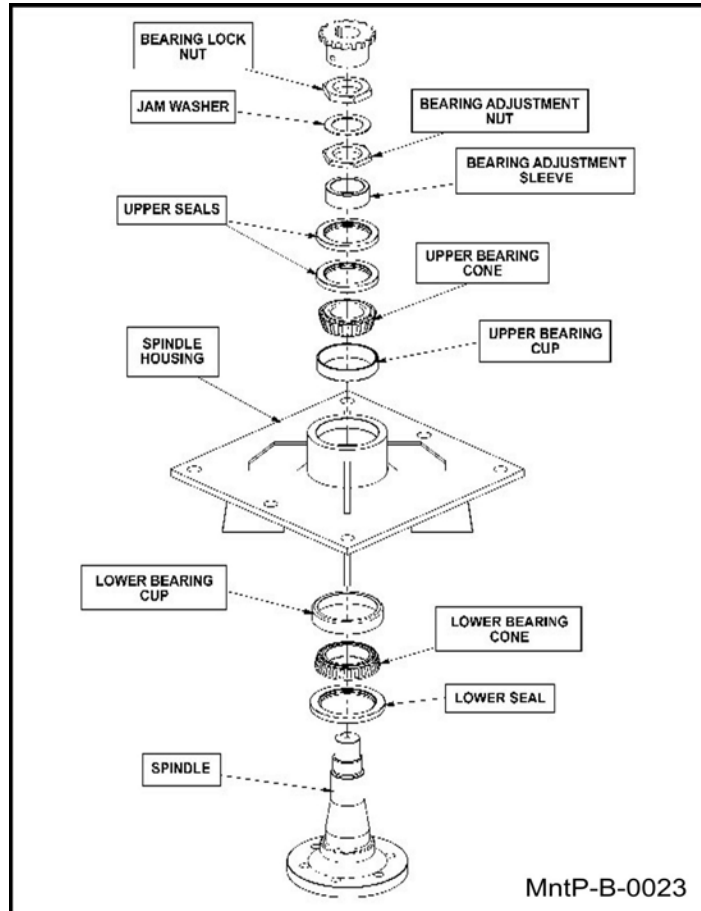

MAINTENANCE

BEARING INSTALLATION

1. Press upper bearing cup in to the spindle housing.
2. Turn the spindle housing over and press in the lower bearing cup.
3. Place the lower bearing cone in the bearing cup. Next press the seal into the spindle housing. The inner lip of the seal must be DOWN, towards the bearing, so lubricant is sealed inside the housing.
4. Install the spindle in the housing. Lightly press the spindle to seat the cone onto the spindle.
5. Support the bottom of the spindle and press the upper bearing cone and bearing adjustment sleeve onto the spindle.
6. **NOTE: The spindle housing must turn freely when seating the bearing cone and sleeve.**
7. Press the two upper seals into the spindle housing. The inner lip of the seals must be UP, away from the bearing, so excess lubricant can escape.
8. Install the bearing adjustment nut (thin nut) so there is 1-1/6" clearance between the nut and the sleeve. Install the jam washer, placing the tab into the key-way. Install the bearing lock nut (thin nut) and hand tighten against jam washer and adjustment nut. See the following section for bearing adjustment.
9. Position the spindle housing horizontally with the drain hole oriented "up". Grease through the zerk with Tiger Spindle Lubricant (part number 06540000) until the grease purges from the drain hole.
10. Install the plug into the drain hole.

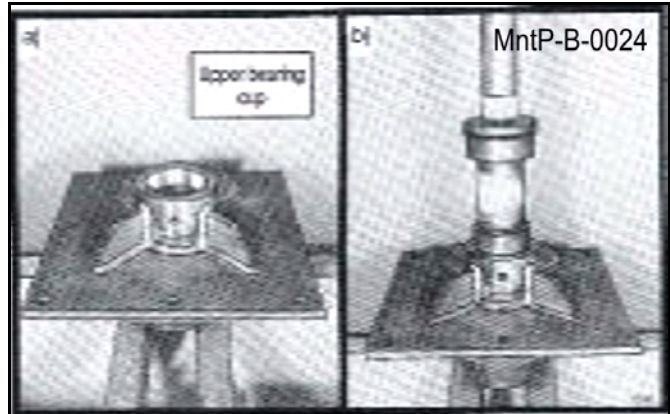

BEARING ADJUSTMENT

1. Clamp the bottom end of the spindle housing securely in a vise so the spindle housing turns freely.
2. Position a magnetic base dial indicator on the outer diameter of the spindle housing. Locate the end of the dial indicator against the flat end of the spindle shaft. The dial indicator will now measure accurately bearing end play.
3. Tighten the bearing adjustment nut until there is .012 inch movement when the spindle housing is pried upward away from the vise jaws.
4. When there is .012 inch free play between the spindle and housing, install the bearing lock nut (thick nut). Hold the adjusting nut securely and tighten the lock nut to 300 ft. lbs. of torque.
5. After the lock nut is tightened, there must be .001 inch to .003 inch of free play when lightly prying up on the spindle housing.

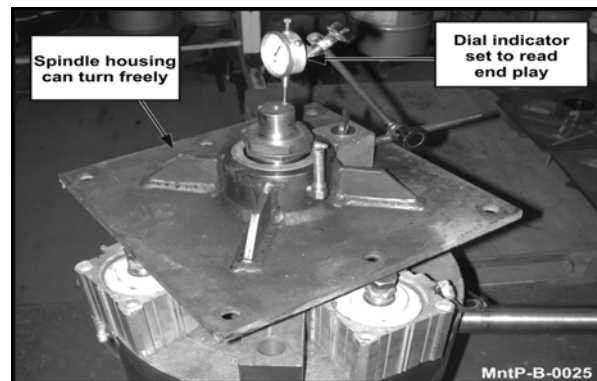

If the end play is correct, .001 inch to .003 inch, bend tabs up on jam washer to prevent the lock nut from loosening.

If the end play is NOT correct, loosen the lock nut and turn the adjustment nut as required and re-tighten the lock nut. Repeat first part of step 5.

MAINTENANCE

Boom Cylinder Removal and Replacement Instructions

1. Clear the area of all personnel before lowering the boom mower head.
2. From the tractor seat with your seat belt fastened around you, Lower the boom mower head to the ground. Extend the boom to the furthest reach and lower the mower head flat on the ground. DO NOT attempt to replace the cylinders with the boom in the raised or transport position.
3. Shut off the tractor, engage the parking brake, place the tractor transmission in the park position, and remove the key before dismounting.
4. Allow the system to cool to room temperature before removing any hydraulic components
5. Wear Safety glasses and impenetrable gloves when working with hydraulic hoses and fittings.
6. Release all oil pressure from the hydraulic circuit by manually stroking each valve section with the tractor engine off. Utilize the Manual Override function if the unit is equipped with an electric over hydraulic valve.
7. Utilize blocks, jack stands or a suitable over head hoist to support the weight of the boom section and remove pressure from the cylinder mounting pins.
8. Check to see that the cylinder to be replaced is not under pressure by moving the cylinder pins by hand. The pins should be loose and should slide from the pin bore easily. If the pins are tight and cannot be moved, the cylinder may be under pressure. Make sure the boom components are properly supported and that the pressure is relieved from the circuit.
9. Cylinder assemblies are heavy and can fall when the pins are removed. Support the hydraulic cylinder with a suitable hoist or jack.
10. Slowly loosen the hydraulic connections to the cylinder. Carefully unscrew hose fitting and allow any remaining pressure to bleed off. Use Extreme Care. Oil must be cool, and the technician should stand to the side to prevent exposure to any hydraulic oil. Always consult the Material Safety Data Sheet and wear any required Personal Protective Equipment. A catch pan may be required to retain any spilled oil.
11. Cap both ends of the fitting with suitably sized metal caps.
12. Remove the cylinder pins starting with the ROD end cylinder pin. Make sure the cylinder is properly supported, and remove the base end cylinder pin. The cylinder may be heavy, use proper lifting techniques to lift and handle the cylinder. If needed, get assistance from another person to safely lift the cylinder from the machine.
13. Measure the distance between the cylinder pin holes and extend the new cylinder the correct length prior to attempting an installation.
14. Install the new cylinder in place and install both cylinder pins and retaining hardware.
15. Remove the metal caps, and re-install the hydraulic hoses.
16. Check the hydraulic reservoir of the boom mower to ensure there is sufficient oil. Follow the manufacturer's recommendations for proper oil type and filtering techniques and requirements to add oil to the system.
17. Clear the area of all persons prior to starting the tractor.
18. Consult the Operator's Manual for instruction in regard to the proper operating procedure.
19. From the tractor seat, with the seat belt fastened, operate the boom to ensure proper operation of the boom function.
20. From the tractor seat, with the seat belt fastened, operate the boom controls to fully extend and retract the new cylinder several times to purge any trapped air from the system.
21. From the tractor seat, with the seat belt fastened, look for signs of and oil leak. If an oil leak is observed, shut the tractor down and follow the steps to remove pressure from the hydraulic circuit. Identify the source of the leak, and resolve the issue.
22. Upon completion of the required repairs, return to Step # 16 to recheck the cylinder for proper operation.

MAINTENANCE

CUTTERSHAFT BEARING REPLACEMENT

1. Remove existing cuttershaft, bearings and string guards.
2. Make sure that the end knives on each end of the cuttershaft are orientated as shown.
3. Apply anti-seize on cuttershaft as shown on next page.
4. Install non-drive side bearing first.
5. Install the top of the string guard on the non-drive side first. Use loctite-271 or equivalent and torque (95 ft-lb or 104ft-lb if you use an extension).
6. Install the bearing and top string guard on the drive side.
7. Center the cuttershaft between the string guards. Use loctite-271 or equivalent and torque (95ft-lb or 104ft-lb if you use an extension) the top string guard on the drive side.
8. Install, use loctite-271 or equivalent, and torque (95ft-lb or 104ft-lb if you use an extension) the bottom string guard on both sides.
9. Make sure the cuttershaft is centered. On the non-drive side, tighten one set-screw in the bearing onto the cuttershaft.
10. Remove the other set-screw and drill a 5/16" hole into the cuttershaft 3/16" deep through the hole in the bearing. BE CAREFUL NOT TO DAMAGE THE THREADS IN THE BEARING HOLE.
11. Replace the set-screw in the bearing, use loctite-271 or equivalent, and tighten onto the cuttershaft through the new hole.
12. Remove the other set-screw and repeat the drilling procedure (Step 10). Replace the set screw as stated in Step 11.
13. Repeat steps 9 through 12 on the drive side.
14. Grease both bearings properly.

See illustration on next page

MAINTENANCE

MAINTENANCE

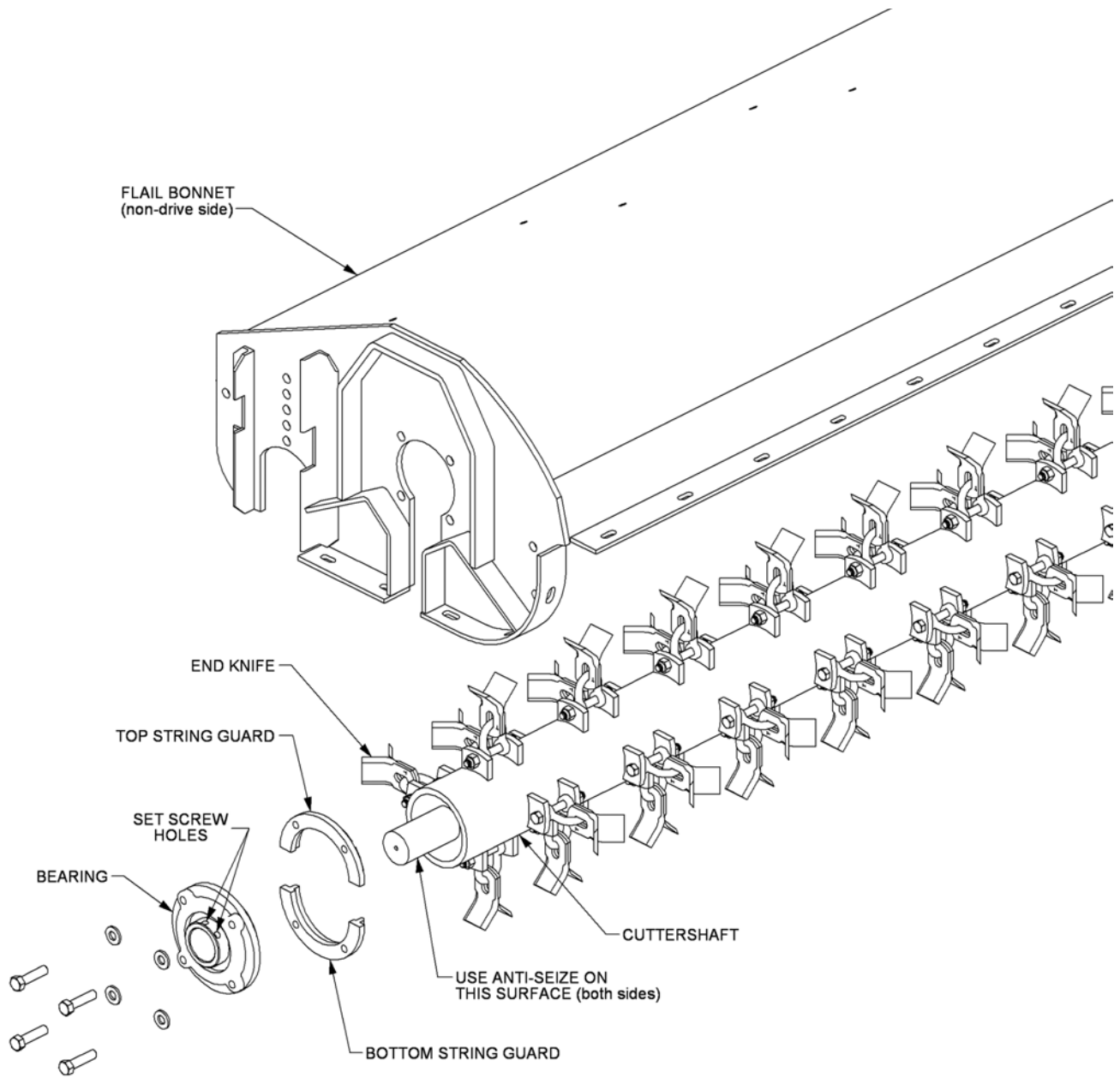

MAINTENANCE

MAINTENANCE

DAILY MAINTENANCE SCHEDULE

The following services should be performed daily or every 8 hours of service, following the detailed maintenance instructions in the operators manual.

_____ Pump Drive Shaft: If required with drive shaft/coupler check for end play and lubricate at zerks.

_____ Crankshaft adapter: If equipped with rubber grommets check condition, replace if missing or damaged.

_____ Pivot points: Inject grease until it appears at ends.

_____ Hydraulic fittings: Check for leaks with paper or cardboard. Tighten fittings or replace hoses immediately.

_____ Knives: Inspect for missing or damaged knives, change (only complete sets) as needed.

_____ Belts: Check/Tighten/Replace belts as needed.

_____ Main Frame/Deck: Unless otherwise specified retorqued bolts according to torque specifications in this section.

_____ Hydraulic Fluid Level: Add, if required, per fluid recommendations.

_____ Rear Flail Drive, Bearing Flange and Shaft Couplers: Grease as instructed in the detailed maintenance section.

_____ Cutter Shaft and Ground Roller: Grease as instructed in the detailed maintenance section.

Service performed by: _____ Date: ____/____/____ Hour

Meter: _____

Maintenance Section

**This page may be copied and used as part of the daily maintenance routine.

PARTS SECTION

NOTES



PART NAME INDEX

PARTS ORDERING GUIDE.....	5
TRUCKAT ASSEMBLY - LEFT SIDE.....	6
TRUCKAT ASSEMBLY - RIGHT SIDE.....	7
TRUCK BED ASSEMBLY - LEFT SIDE.....	8
BUMPER ASSEMBLY.....	9
TRUCK BED ASSEMBLY - RIGHT SIDE.....	10
RESERVOIR TANK ASSEMBLY.....	12
LIFT VALVE MOUNT.....	14
NOTES.....	15
ENGINE COMPONENTS.....	16
ENGINE DRAIN.....	17
ENGINE BREAKDOWN - AIR INTAKE.....	18
ENGINE BREAKDOWN - EXHAUST.....	19
ENGINE BREAKDOWN - MOUNTED RELAYS.....	20
ENGINE BREAKDOWN - RADIATOR.....	21
ENGINE ENCLOSURE.....	22
ENGINE ENCLOSURE - HOOD.....	23
HYDRAULIC ENCLOSURE.....	24
MOWER HYDRAULICS.....	26
COOLER HYDRAULICS.....	28
COOLER MOUNTING.....	30
JOYSTICK AND SWITCHBOX MOUNT.....	32
ENGINE CONSOLE BREAKDOWN.....	34
FIRE EXTINGUISHER MOUNT.....	36
HANDRAIL.....	37
SAFETY SWITCHES.....	38
SAFETY SCREEN ASSEMBLY.....	40
NOTES 1.....	42
DECK STOP - TRB50.....	43
DECK STOP - TBF50 & TBF63.....	44
HEADACHE RACK ASSEMBLY.....	45
LIGHT BAR OPTION.....	46
SPARE TIRE OPTION.....	47
2 FOOT TOOLBOX OPTION.....	48
4 FOOT TOOLBOX OPTION.....	49
ELECTRONIC PROPORTIONAL LIFT VALVE BREAKDOWN.....	50
PUMP BREAKDOWN.....	52
AIR RIDE PARTS LIST - AIR BAG ASSY.....	54
AIR RIDE PARTS LIST - COMPRESSOR ASSY.....	56
AIR SYSTEM COVER ASSEMBLY.....	58

TRUCKAT

PART NAME INDEX

AIR RIDE DIAGRAM.....	59
AIR RIDE SCHEMATIC.....	60
LIMIT STRAP INSTALLATION.....	61
LIFT VALVE HYDRAULIC DIAGRAM.....	62
LIFT VALVE HYDRAULIC DIAGRAM - CONTINUED.....	63
AUXILLARY ENGINE CONSOLE SCHEMATIC.....	64
AUXILLARY ENGINE CONSOLE SCHEMATIC - CONTINUED.....	65
SWITCH BOX SCHEMATIC.....	66
JOYSTICK AND SWITCH BOX DIAGRAM.....	67
SWITCH BOX BREAKDOWN.....	68
NOTES 2.....	69
RH STEER MODIFICATIONS - PAGE 1.....	70
RH STEER MODIFICATIONS - PAGE 2.....	71
RH STEER MODIFICATIONS - PAGE 3.....	72
RH STEER MODIFICATIONS - PAGE 4.....	73
RH STEER MODIFICATIONS - PAGE 5.....	74
RH STEER MODIFICATIONS - PAGE 6.....	75
RH STEER MODIFICATIONS - PAGE 7.....	76
RH STEER MODIFICATIONS - PAGE 8.....	77
RH STEER MODIFICATIONS - PAGE 9.....	78

PARTS ORDERING GUIDE

The following instructions are offered to help eliminate needless delay and error in processing purchase orders for the equipment in this manual.

1. The Parts Section is prepared in logical sequence and grouping of parts that belong to the basic machine featured in this manual. Part Numbers and Descriptions are given to help locate the parts and quantities required.
2. The Purchase Order must indicate the **Name and Address** of the person or organization ordering the parts, **who should be charged**, and if possible, the **serial number of the machine** for which the parts are being ordered.
3. The purchase order must clearly list the **quantity of each part**, the complete and correct **part number**, and the basic **name of the part**.
4. The manufacturer reserves the right to substitute parts where applicable.
5. Some parts may be unlisted items which are special production items not normally stocked and are subject to special handling. Request a quotation for such parts before sending a purchase order.
6. The manufacturer reserves the right to change prices without prior notice.

NOTE: When ordering replacement decals, refer to the part numbers and descriptions listed in the safety section in the front of this manual.



For maximum safety and to guarantee optimum product reliability, always use genuine **Tiger** replacement parts. The use of inferior replacement parts may cause premature or catastrophic failure which could result in serious injury or death.

Direct any questions regarding parts to:

Tiger Corporation
3301 N. Louise Ave.
Sioux Falls, SD 57107
1-800-843-6849
1-605-336-7900

TRUCKAT ASSEMBLY - LEFT SIDE

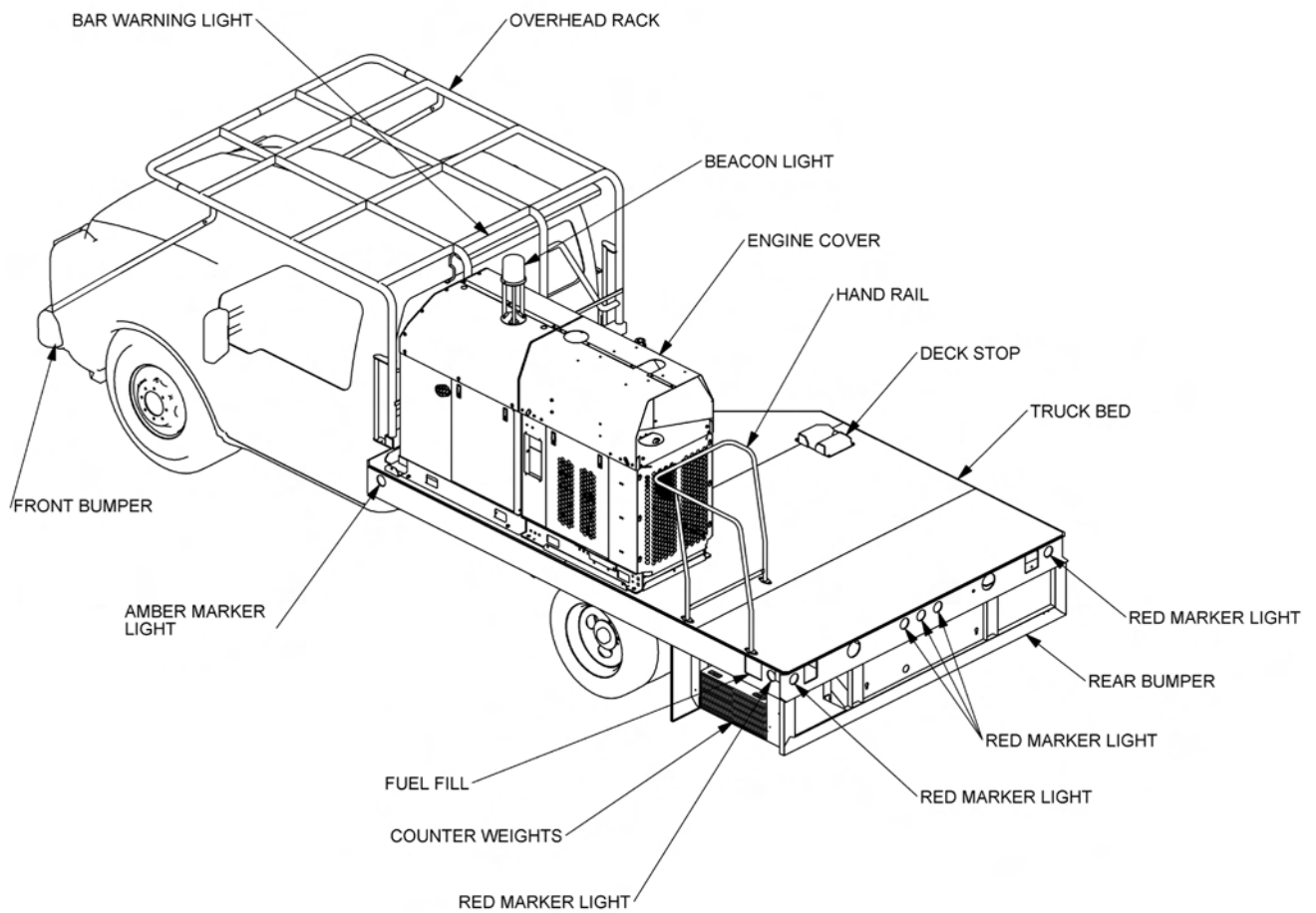

TRUCKAT ASSEMBLY - RIGHT SIDE

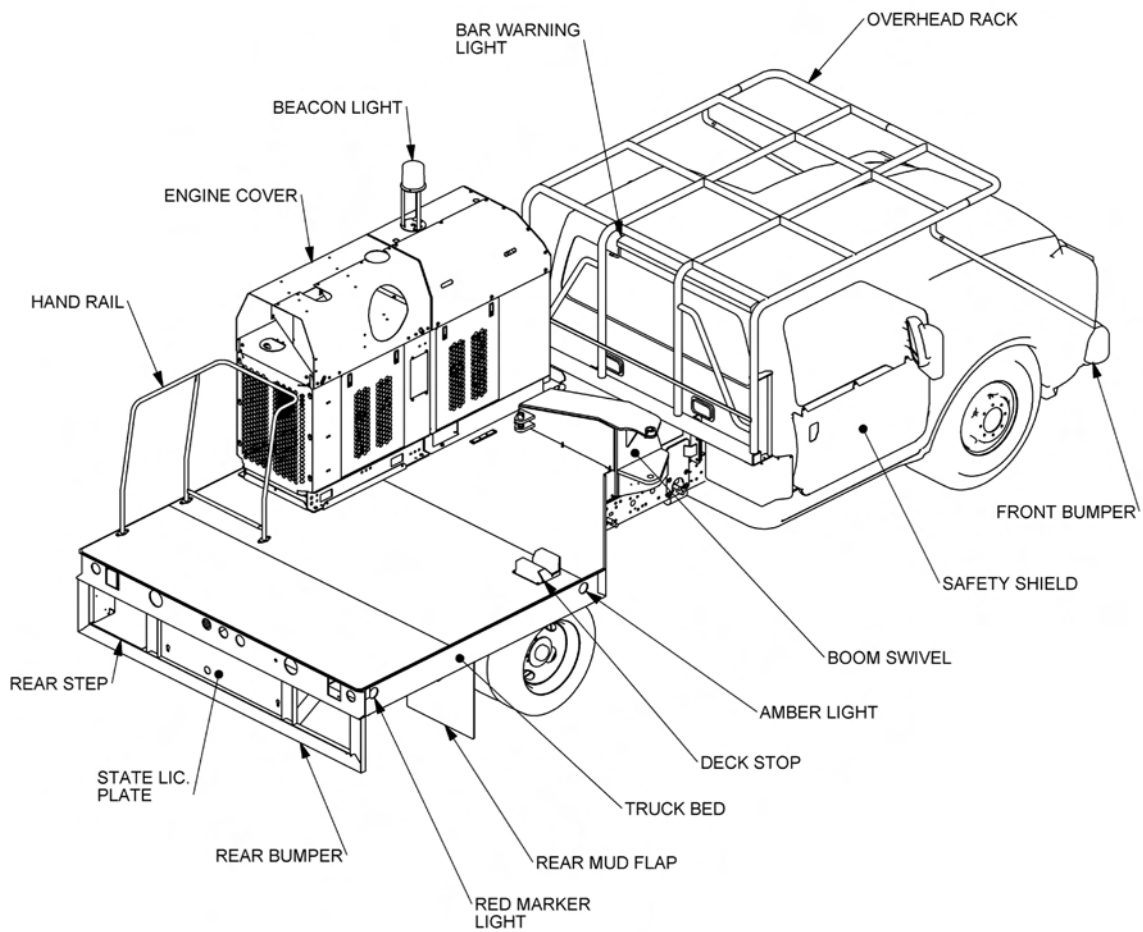

TRUCK BED ASSEMBLY - LEFT SIDE

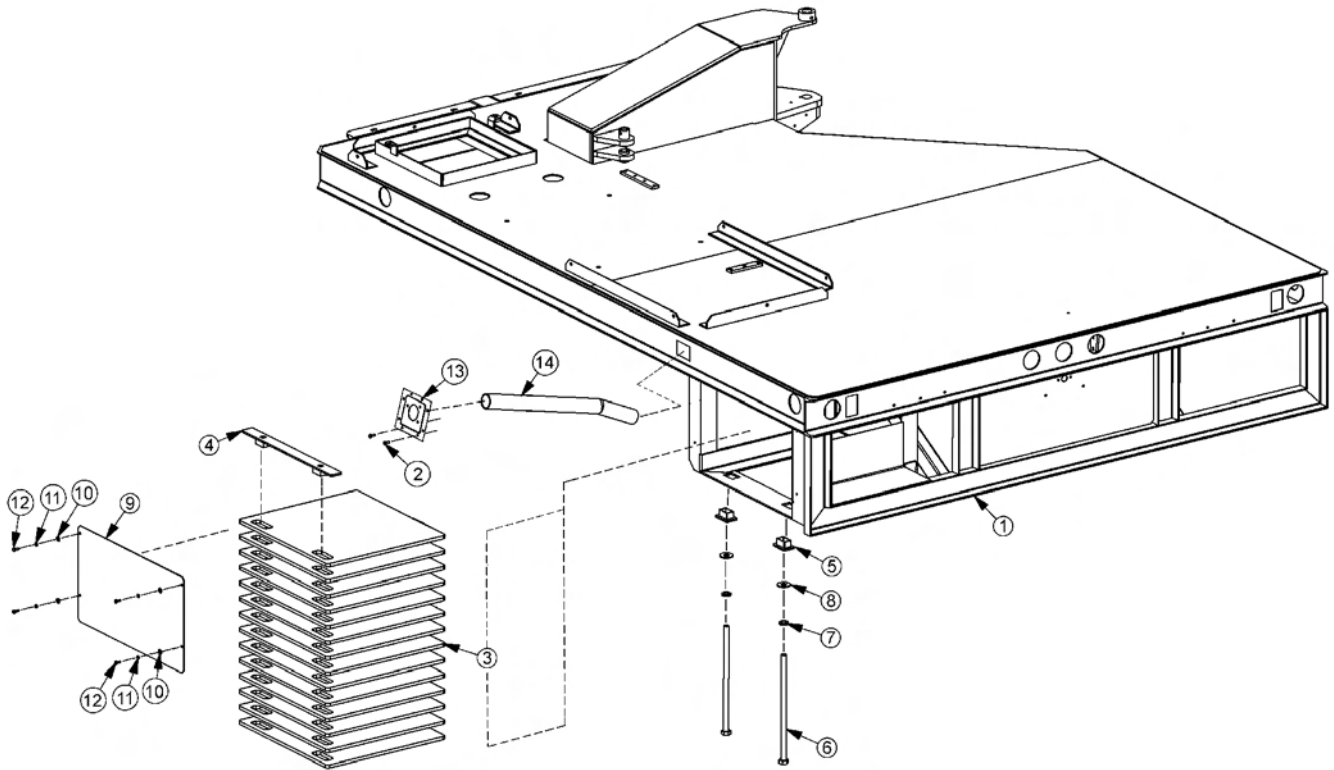

ITEM	PART NO.	QTY.	DESCRIPTION
1	06300134	1	MAIN FRAME
-----	06200515	1	COUNTERWEIGHT KIT,TRUCKAT®4WD (OPTIONAL)
2	06537036	6	CAPSCREW,#10-32 X 3/4",SLF TAP
3	35018	14	COUNTERWEIGHT
4	35253	1	TIE DOWN,UPPER
5	35252	2	TIE DOWN,LOWER
6	31455	2	CAPSCREW,3/4" X 17",NC
7	21993	2	LOCKWASHER,3/4"
8	22021	2	FLATWASHER,3/4"
9	35254	1	COVER,COUNTERWEIGHTS
10	22014	5	FLATWASHER,1/4"
11	21986	6	LOCKWASHER,1/4"
12	21529	2	CAPSCREW,1/4" X 3/4",NC
13	-----	-	BRKT,FUEL FILLER (EXISTING TRUCK PART)
14	35229	1	HOSE 2" FUEL FILLER

TRUCKAT

BUMPER ASSEMBLY

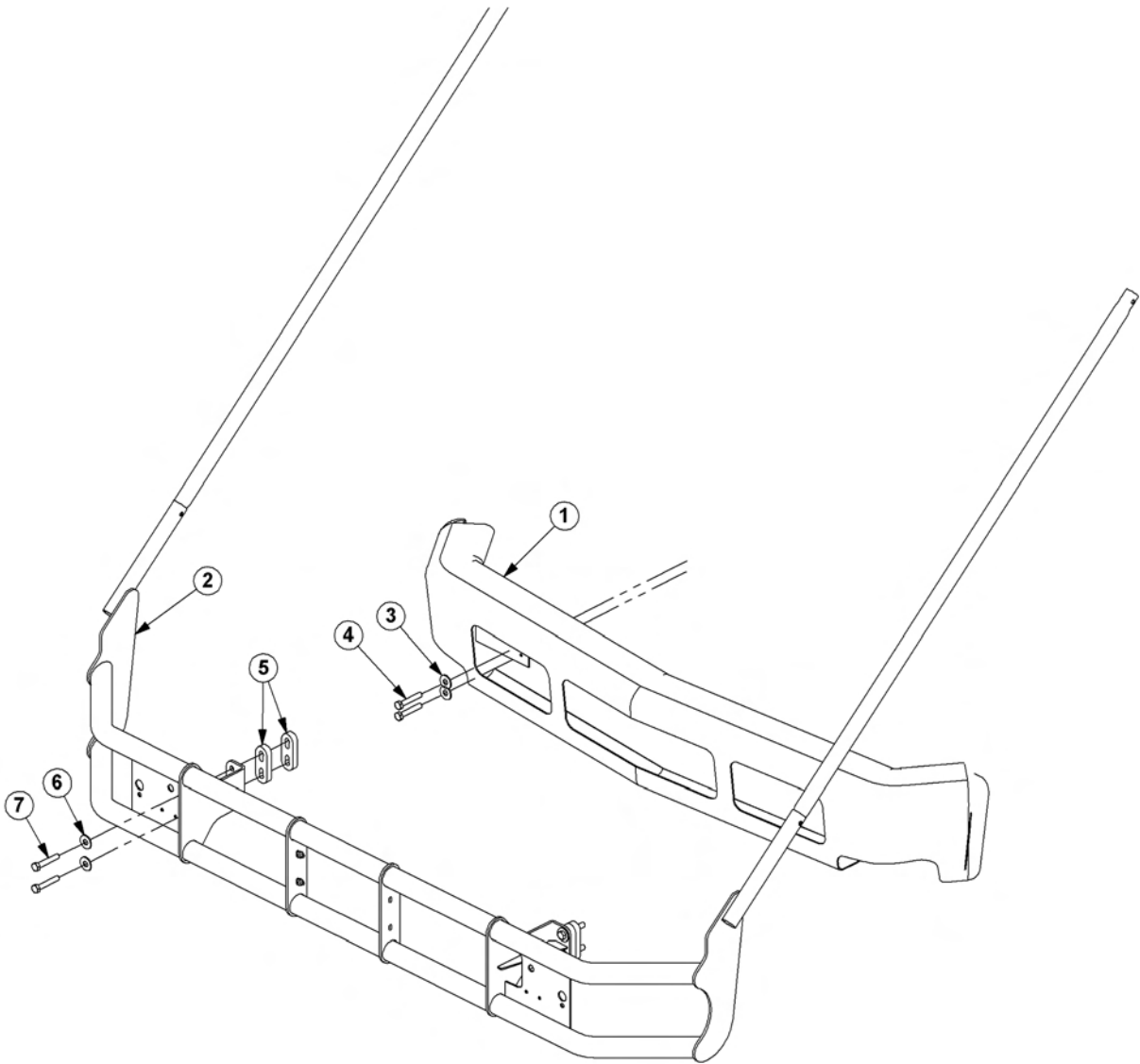

ITEM	PART NO.	QTY.	DESCRIPTION
1	-----	-	BUMPER (EXISTING TRUCK PART)
2	06330029	1	BUMPER MOUNT,2011
3	-----	-	FLATWASHER (EXISTING TRUCK PART)
4	-----	-	CAPSCREW (EXISTING TRUCK PART)
5	06400657	4	SPACER,BUMPER
6	22018	4	FLATWASHER,1/2",WIDE
7	06530519	4	CAPSCREW,12MM X 70MM,1.75P

TRUCKAT

TRUCK BED ASSEMBLY - RIGHT SIDE

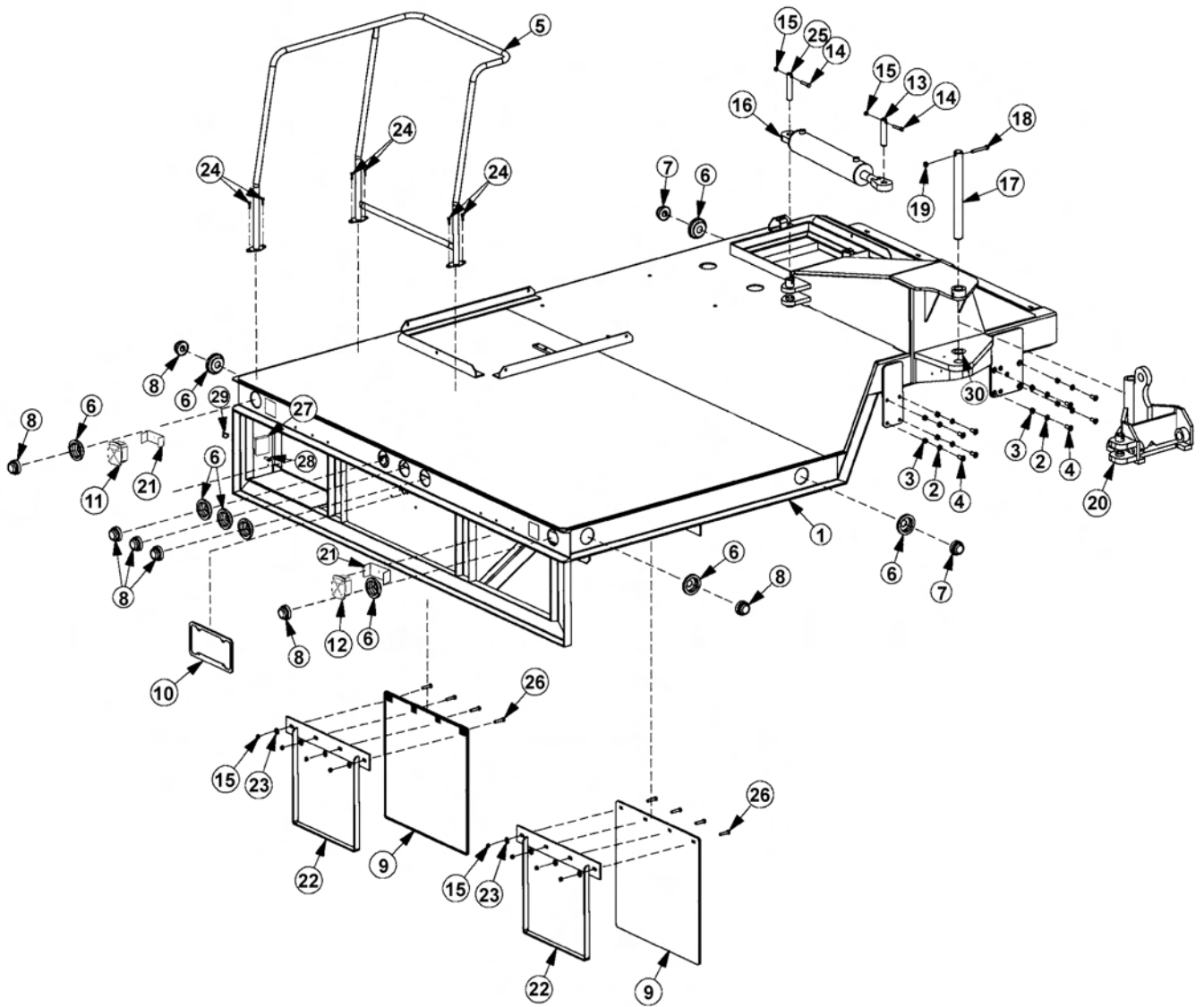

TRUCK BED ASSEMBLY - RIGHT SIDE

Continued...

ITEM	PART NO.	QTY.	DESCRIPTION
1	06300134	1	MAIN FRAME
2	21992	26	LOCKWASHER,5/8"
3	6T2408	26	HEX NUT,5/8",NF
4	06530100	26	CAPSCREW,5/8" X 2",SKT HD,NF
5	35128	1	HANDRAIL
6	35116	9	LIGHT GROMMET,RUBBER
7	06510015	2	AMBER LIGHT
8	06510014	7	RED LIGHT
9	35178	2	MUD FLAP
10	-----	-	LICENSE PLATE HOLDER (EXISTING TRUCK PART)
11	-----	-	LEFT TAIL LIGHT (EXISTING TRUCK PART)
12	-----	-	RIGHT TAIL LIGHT (EXISTING TRUCK PART)
13	35190	1	PIN,1" X 5"
14	21634	2	CAPSCREW,3/8" X 2",NC
15	21627	10	NYLOCK NUT,3/8",NC
16	33705	1	CYLINDER,SWIVEL
17	TB3014	1	PIN,SWIVEL BRACKET
18	21688	1	CAPSCREW,7/16" X 3-1/4",NC
19	21677	1	NYLOCK NUT,7/16",NC
20	35017	1	BOOM SWIVEL
21	06410035	2	TAIL LIGHT BRKT
22	35180	2	RETAINER,W/BAR,MUDFLAP
23	22016	8	FLATWASHER,3/8"
24	06530202	6	CAPSCREW,3/8" X 3/4",SELF TAPPING
25	35191	1	PIN,SWIVEL TAPPED
26	21633	4	CAPSCREW,3/8" X 1-3/4",NC
27	6T3922	1	SWTCH,BACKUP ALARM
28	27260	3	SCREW,MACHINE,10-24 X 1"(RD HEAD)
29	24890	3	NYLOCK NUT,10-24
30	06520049	1	THRUST WASHER

TRUCKAT

RESERVOIR TANK ASSEMBLY

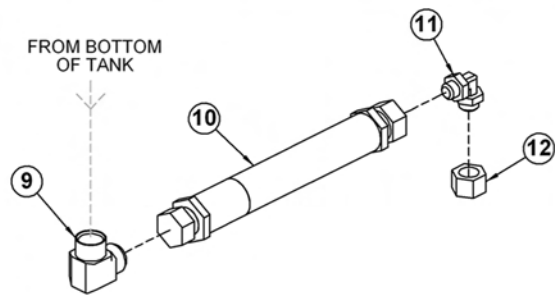
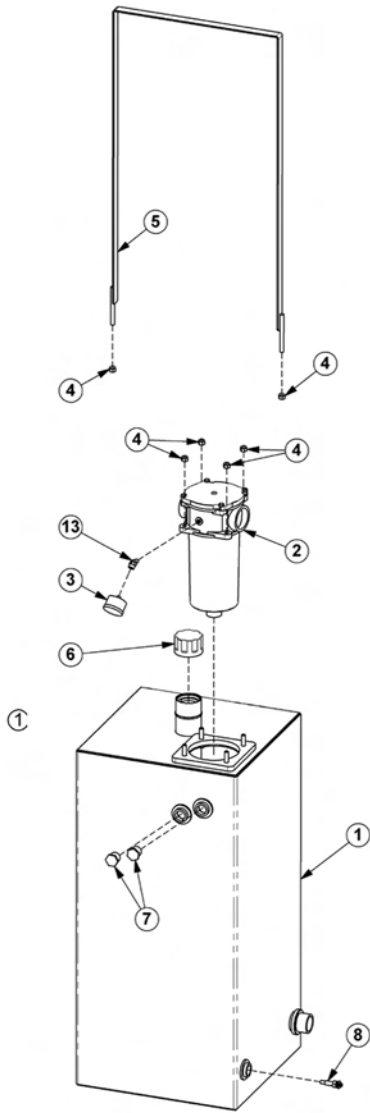

RESERVOIR TANK ASSEMBLY

Continued...

ITEM	PART NO.	QTY.	DESCRIPTION
---	35082	1	RES TANK ASSY (ITEMS 1, 2,4 AND 6)
1	35002	1	RES TANK,WLDMNT
2	06505044	1	FILTER ASSY, IN-TANK,COMPLETE
---	35259	1	ELEMENT, FILTER,10 MICRON
3	6T0649	1	FILTER GAUGE
4	21627	6	NYLOCK NUT,3/8",NC
5	35071	1	STRAP,RES TANK
6	35054	1	BREATHER CAP,FILLER NECK,O-RING
7	6T1209	2	SIGHT GLASS
8	06520072	1	OIL TEMP SENDER
9	34465	1	ELBOW,3/4"MP X 3/4"MOR
10	06500374	1	HOSE,1/2" X 18"
11	06503096	1	ELBOW,1/2"MJ X 1/2"MJ
12	06503097	1	CAP,1/2"MJ
13	TF4887	1	ELBOW,STREET,1/8" X 45

LIFT VALVE MOUNT

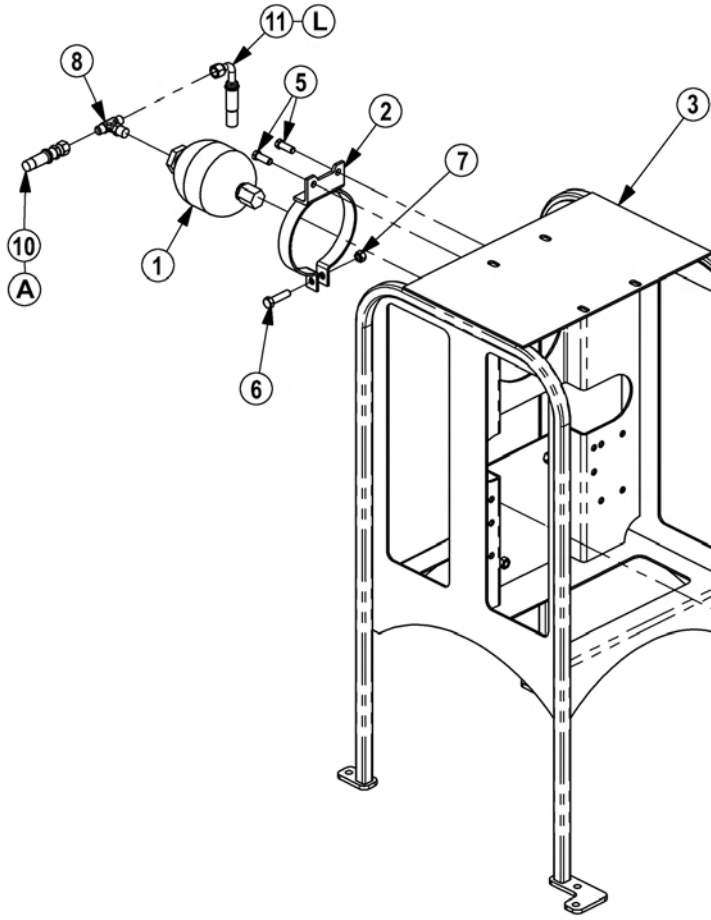

HOSE ROUTING

- A - TO ACCUMULATOR
- B - TO MAIN BOOM CYLINDER BUTT
- C - TO SECONDARY CYLINDER GLAND
- D - TO SECONDARY CYLINDER BUTT
- E - TO DECK ROLL CYLINDER GLAND
- F - TO DECK ROLL CYLINDER BUTT
- G - TO SWIVEL CYLINDER GLAND
- H - TO SWIVEL CYLINDER BUTT
- J - TO SHIELD CYLINDER GLAND
- K - TO SHIELD CYLINDER BUTT
- L - TO MAIN BOOM CYLINDER GLAND

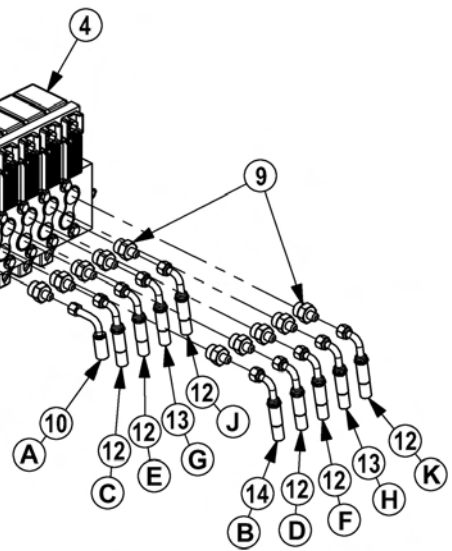

ITEM	PART NO.	QTY.	DESCRIPTION
1	24300	1	ACCUMULATER
2	23888	1	BRKT,ACCUMULATOR
3	06340037	1	VALVE MOUNT
4	06502098	1	LIFT VALVE
5	21630	2	CAPSCREW,3/8" X 1",NC
6	21632	1	CAPSCREW,3/8" X 1-1/2",NC
7	21627	1	NYLOCK NUT,3/8",NC
8	34020	1	TEE,BRANCH,3/8"MJ X 1/2"MOR X 3/8"MJ
9	32807	10	ADAPTER,5/8"MOR X 3/8"MJ
10	35250	1	HOSE,1/4" X 44"
11	35108	1	HOSE,1/4" X 146"
12	35109	6	HOSE,1/4" X 126"
13	35110	2	HOSE,1/4" X 76"
14	35111	1	HOSE,1/4" X 140"

NOTES

NOTES

ENGINE COMPONENTS

RIGHT SIDE OF ENGINE

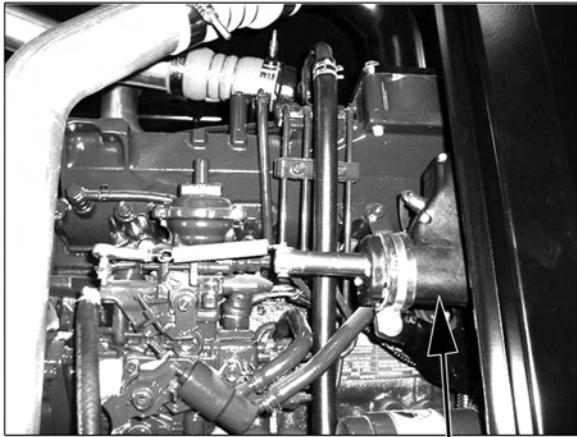

**THROTTLE ACTUATOR
P/N 06520214**

FRONT OF ENGINE

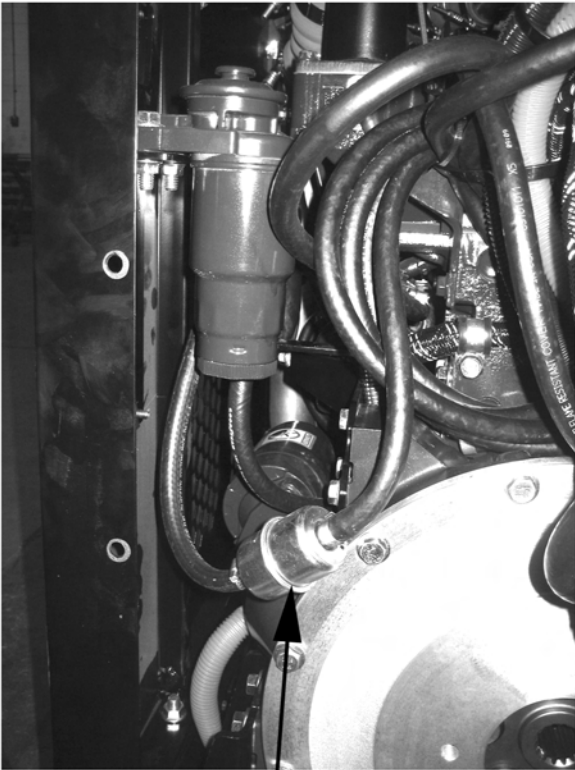

**IN-LINE FUEL FILTER
P/N 3826094**

LEFT SIDE OF ENGINE

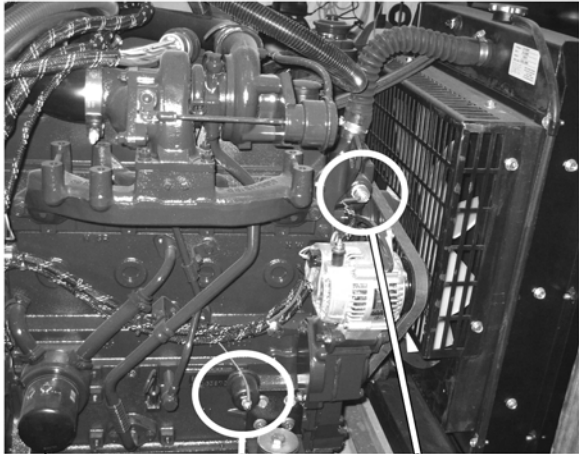

**OIL FILTER
P/N 06520097**

**OIL PRESSURE
SENDING UNIT
P/N 06505080**

**COOLANT TEMP
SENDING UNIT
P/N 06505113**

ENGINE DRAIN

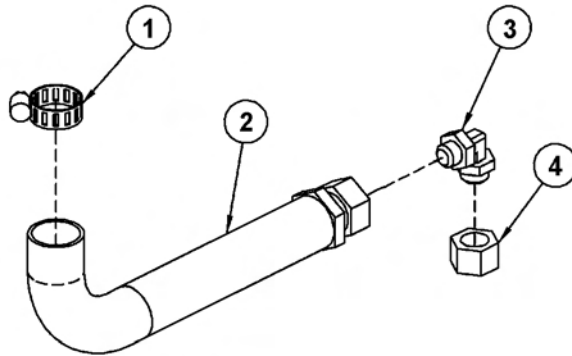

ITEM	PART NO.	QTY.	DESCRIPTION
1	33983	1	HOSE CLAMP,#10
2	06500383	1	HOSE,3/4" X 22"
3	06503096	1	ELBOW,1/2" MJ X 1/2" MJ
4	06503097	1	CAP,1/2"

ENGINE BREAKDOWN - AIR INTAKE

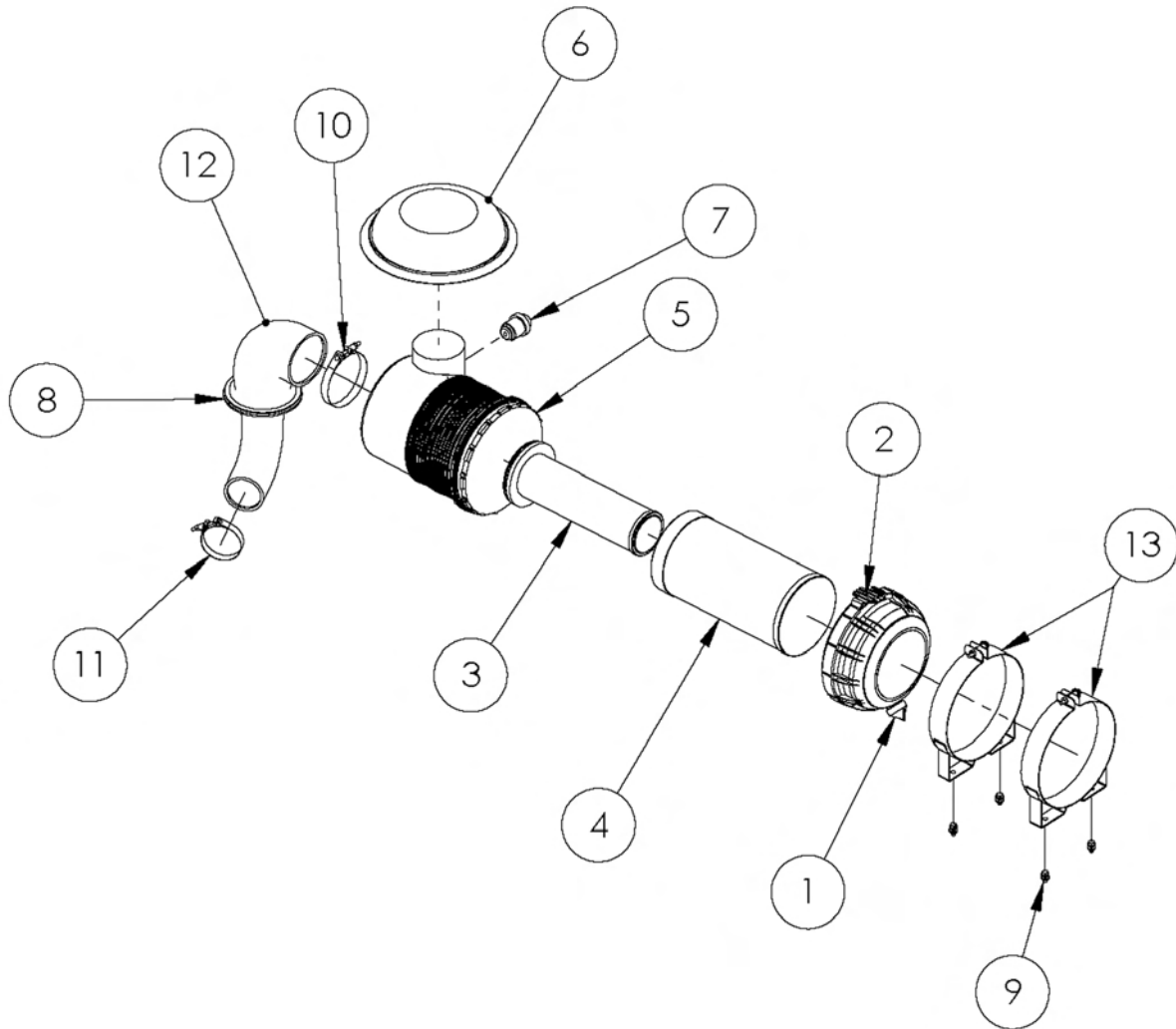

ITEM	PART NO.	QTY.	DESCRIPTION
1	3946457S	1	VALVE,DUST EJECTION
2	3946463S	1	ASSEMBLY,COVER
3	06520477	1	ELEMENT,SECONDARY
4	06520476	1	ELEMENT,PRIMARY
5	AH19479	1	HOUSING,AIR CLEANER
6	3946464S	1	HOOD,RAIN
7	135501-00830	1	INDICATOR,RESTRICTION
8	63595K44	1	SEAL,AIR INTAKE
9	MHK178-A	1	KIT,HARDWARE
10	200-110	1	CLAMP,T-BOLT W/ BRIDGE
11	210-86	1	CLAMP,T-BOLT W/ BRIDGE
12	MAI299-A	1	HOSE,MOLDED INTAKE
13	3946456S	2	BAND,MOUNTING

TRUCKAT

ENGINE BREAKDOWN - EXHAUST

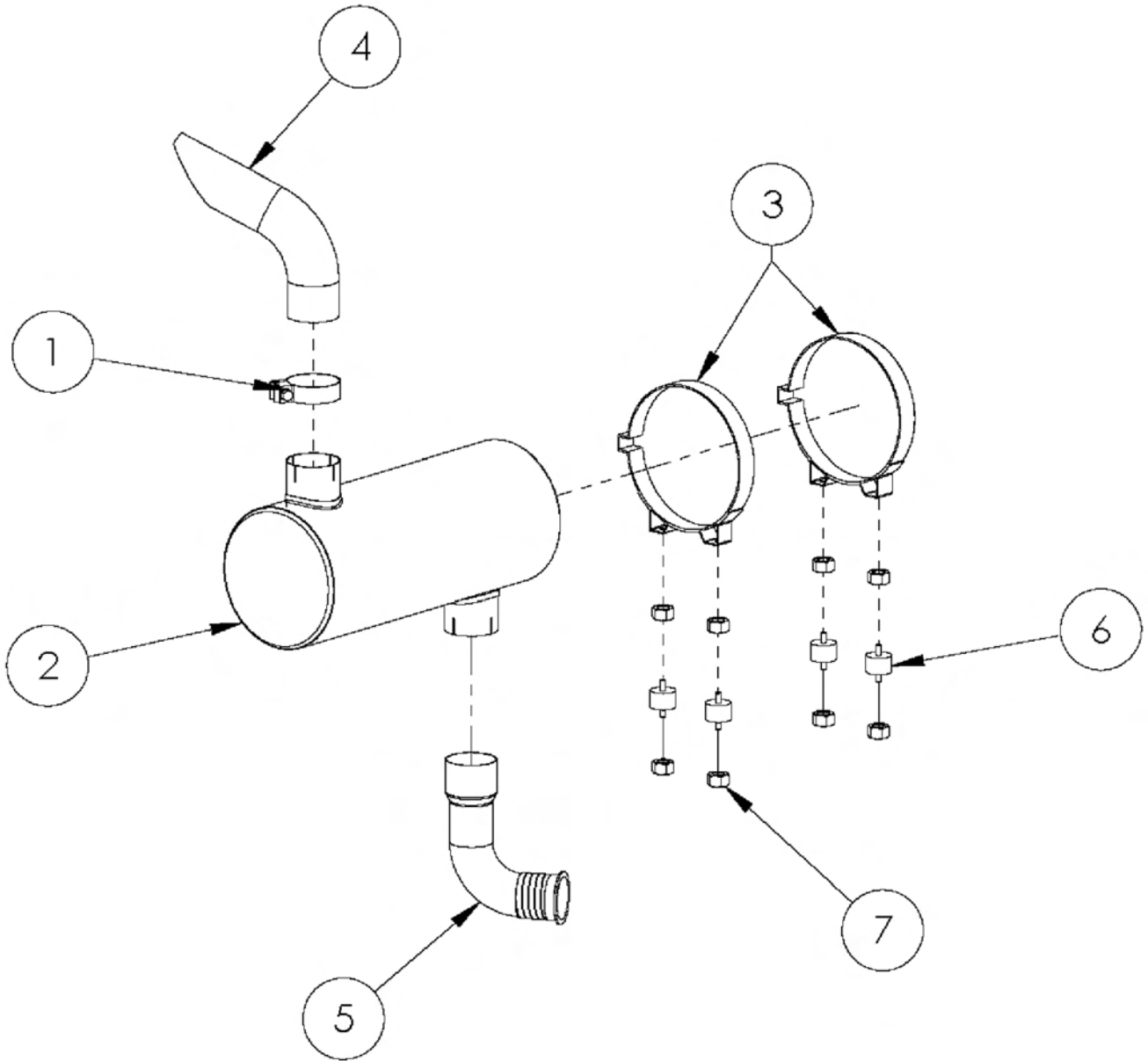

ITEM	PART NO.	QTY.	DESCRIPTION
1	90873A	1	CLAMP,ACCUSEAL
2	201564N	1	MUFFLER,SIDE IN - SIDE OUT
3	Q27184	2	BAND,CLAMP,MUFFLER
4	MXS200-A	1	STACK,ANGLED
5	MXS199-A	1	W/A,EXHAUST ELBOW
6	50872-1	1	ISOMOUNT,HI-TEMP
7	MHK182-A	1	KIT,HARDWARE

ENGINE BREAKDOWN - MOUNTED RELAYS

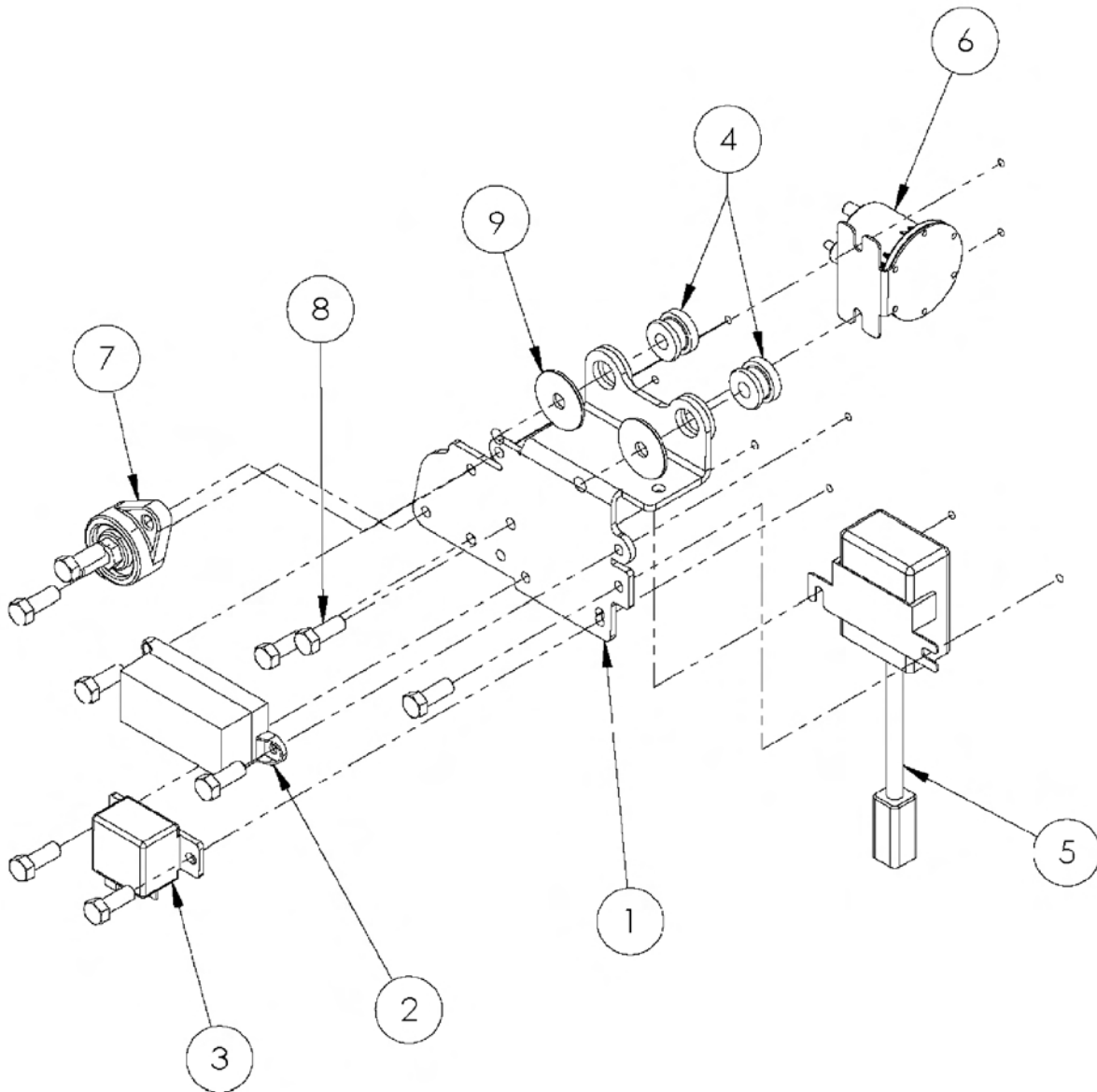

ITEM	PART NO.	QTY.	DESCRIPTION
1	MEG71-B	1	BRACKET,RELAY
2	46038	1	HOLDER,FUSE
3	0332-002-156-TTS-106		RELAY,STARTER
4	60220	2	ISOMOUNT,CENTER BUSHING
5	600-815-9610	1	CONTROLLER,GRID HEAT TIMER
6	684-1251-212	1	RELAY,TROMBETTA 12V
7	BLU2003	1	STUD,ISOLATING
8	MHK180-A	1	KIT,HARDWARE
9	0181	2	WASHER,SNUBBING

TRUCKAT

ENGINE BREAKDOWN - RADIATOR

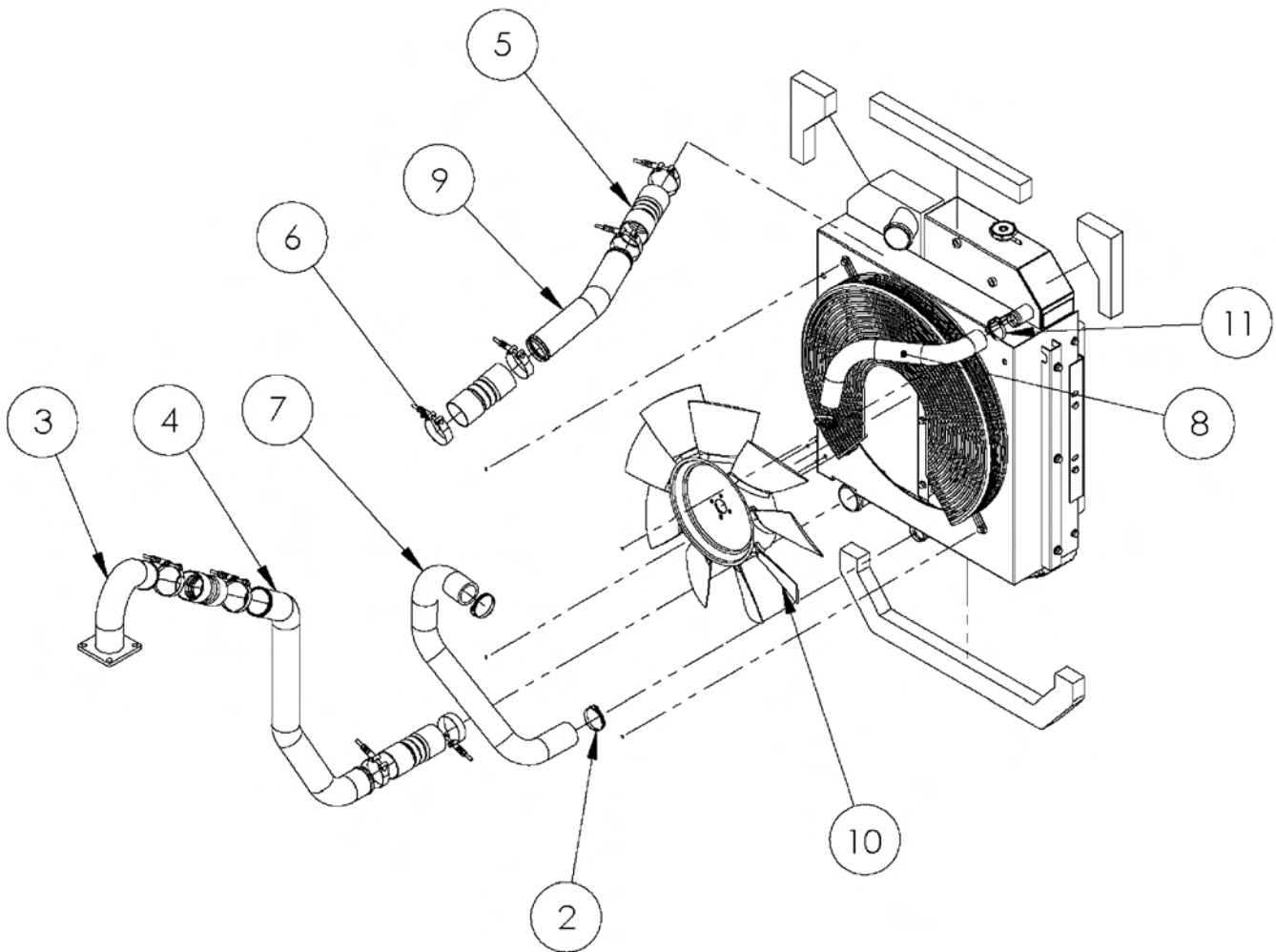

ITEM	PART NO.	QTY.	DESCRIPTION
1	MHK164-A	1	KIT,HARDWARE
2	28028	2	#28 HOSE CLAMP
3	MAI312-A	1	TUBE,CAC HOT
4	MAI311-A	1	TUBE,CAC COLD
5	367-250-060	4	HOSE,2.50" CHARGE AIR COOLER
6	250-73B	8	CLAMP,SPRING LOADED T-BOLT
7	MCA174-A	1	HOSE,LOWER RADIATOR
8	MCA175-A	1	HOSE,UPPER RADIATOR
9	MAI329-A	1	TUBE,CAC HOT
10	444142-22	1	FAN,22" PUSHER
11	HARHS32	2	#32 HOSE CLAMP

ENGINE ENCLOSURE

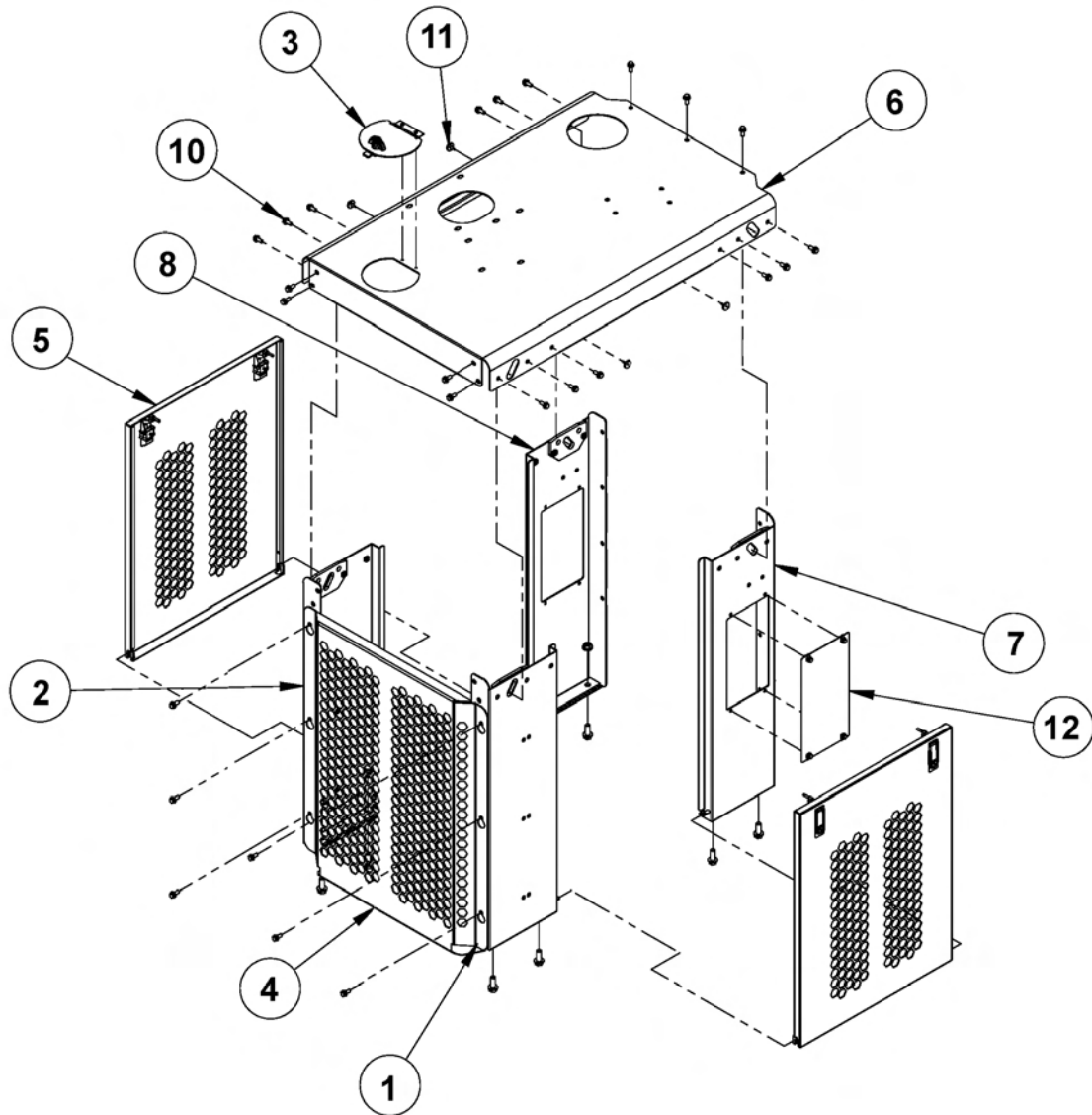

ITEM	PART NO.	QTY.	DESCRIPTION
1	MEN85-A	1	PANEL W/A,FRONT LH
2	MEN86-A	1	PANEL W/A,FRONT RH
3	MAS31-A	1	LID,LOCKABLE
4	MEN94-A	1	PANEL,FRONT GRILL
5	MAS74-A	1	PANEL,DOOR ASSY
6	MEN89-C	1	PANEL W/A, TOP
7	MEN90-B	1	PANEL W/A,REAR LH
8	MEN91-B	1	PANEL W/A,REAR RH
10	MHK162-A	1	KIT,HARDWARE
11	9310K124	4	BUMPER,RUBBER PUSH-IN
12	MAS90-A	1	PANEL,FILLER

ENGINE ENCLOSURE - HOOD

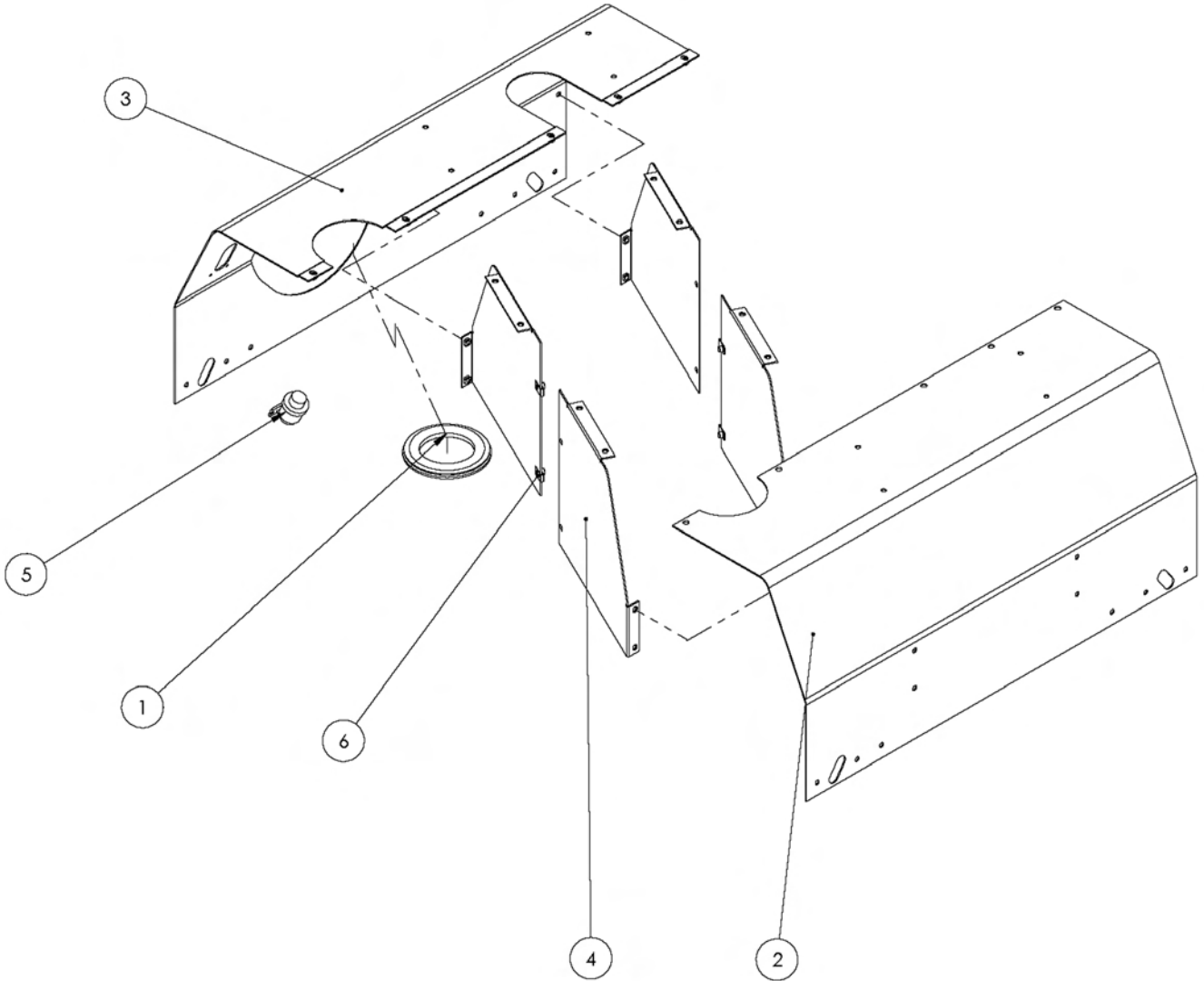

ITEM	PART NO.	QTY.	DESCRIPTION
1	63595K44	1	SEAL,AIR INTAKE
2	MEN148-A	1	HOOD PANEL,LEFT
3	MEN149-B	1	HOOD PANEL,RIGHT
4	MEN150-A	4	DIVIDER,HOOD ASSY
5	AE36501-005251		RESTRICTION INDICATOR
6	CLIP_NUT_5_14		CLIP,NUT

HYDRAULIC ENCLOSURE

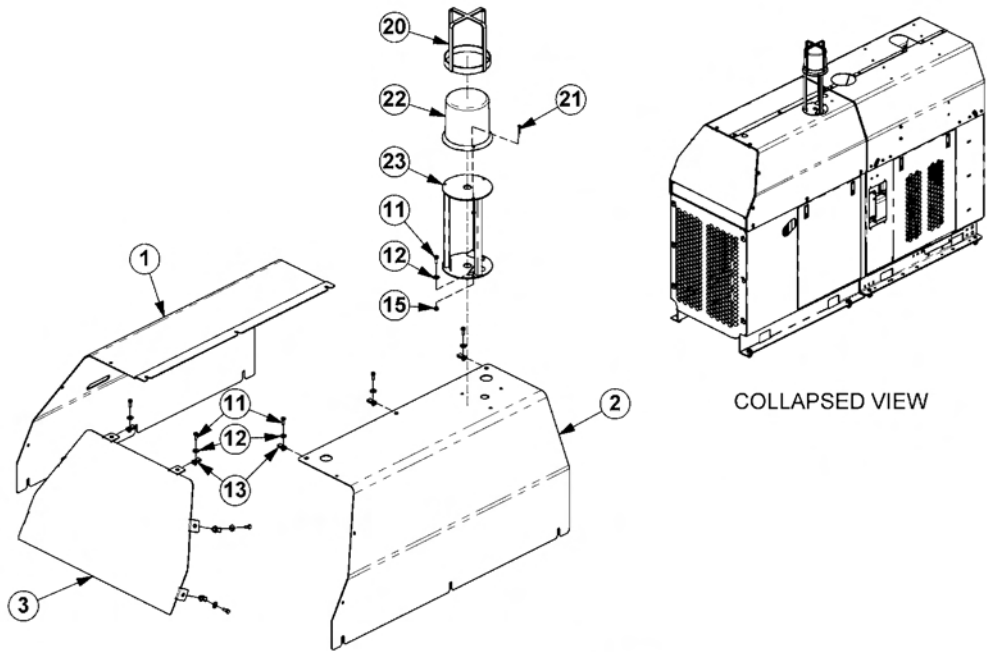

COLLAPSED VIEW

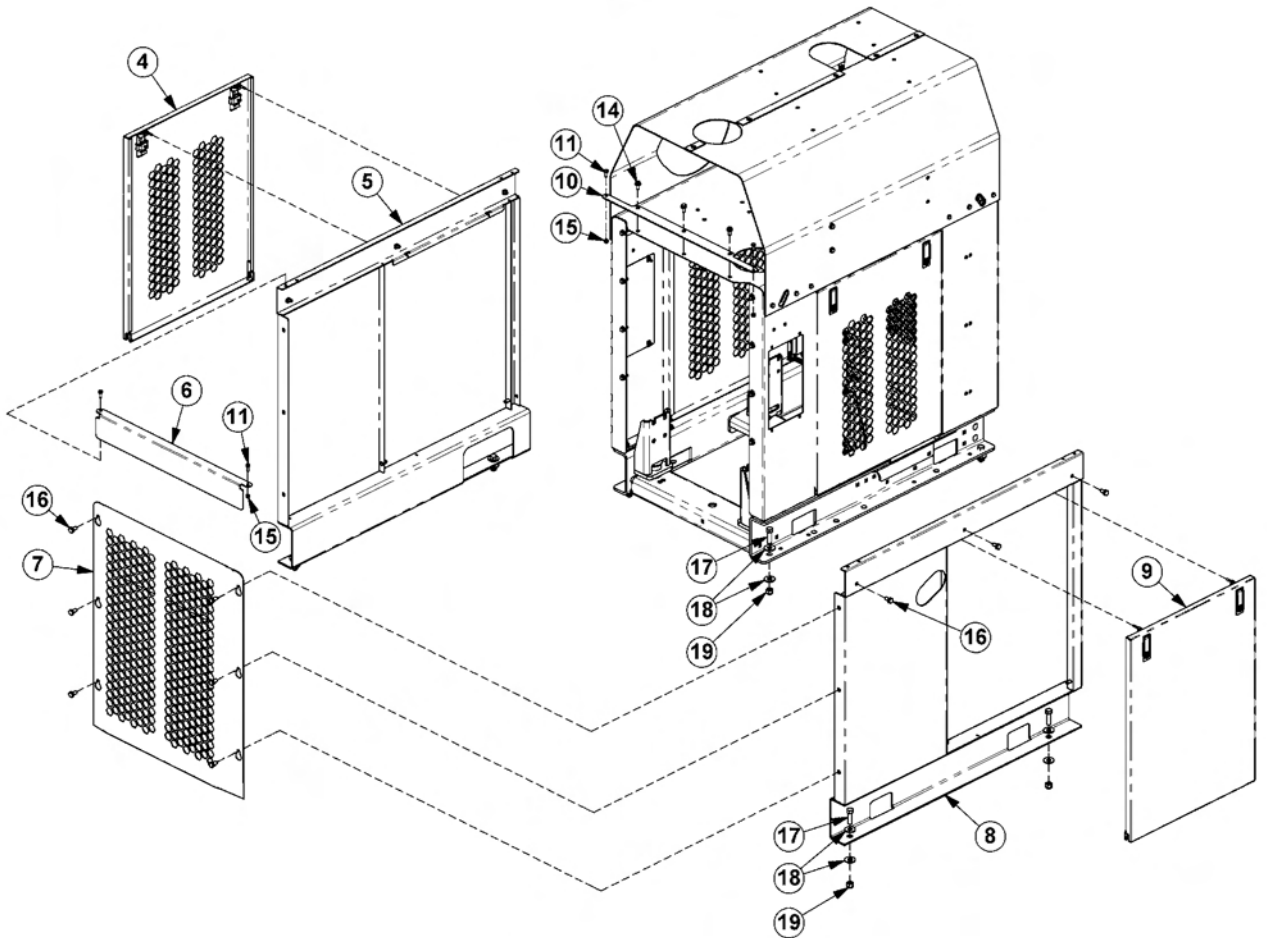

HYDRAULIC ENCLOSURE

Continued...

ITEM	PART NO.	QTY.	DESCRIPTION
---	06770051	1	ENCLOSURE,HYDRAULIC,ASSY
1	06411365	1	ENCLOSURE, TOP, LEFT
2	06411364	1	ENCLOSURE, TOP, RIGHT
3	06411366	1	ENCLOSURE, TOP, END
4	MAS74-A	1	DOOR, PERFERATED
5	06370190	1	ENCLOSURE, LEFT
6	06411368	1	BRACE, REAR, ENCLOSURE
7	MEN87-A	1	PANEL, REAR, ENCLOSURE
8	06370191	1	ENCLOSURE, RIGHT
9	MAS108-A	1	DOOR, SOLID
10	06401521	1	BRACE, FRONT, ENCLOSURE
11	21529	16	CAPSCREW, 1/4" X 3/4", NC
12	22014	12	FLATWASHER, 1/4"
13	35176	9	U-NUT, 1/4", NC
14	21579	3	CAPSCREW, 5/16" X 3/4", NC
15	21527	7	NYLOCK NUT, 1/4", NC
16	28733	12	CAPSCREW, SHOULDER, 3/8" X 3/4", NC
17	21783	8	CAPSCREW, 5/8" X 2", NC
18	33764	16	FLATWASHER, 5/8"
19	21777	8	NYLOCK NUT, 5/8", NC
20	33896	1	BRUSH GUARD, BEACON
21	27260	3	SCREW, MACHINE, 10-24 X 1"
22	33883	1	BEACON LIGHT, AMBER
23	06370054	1	STROBE MOUNT

MOWER HYDRAULICS

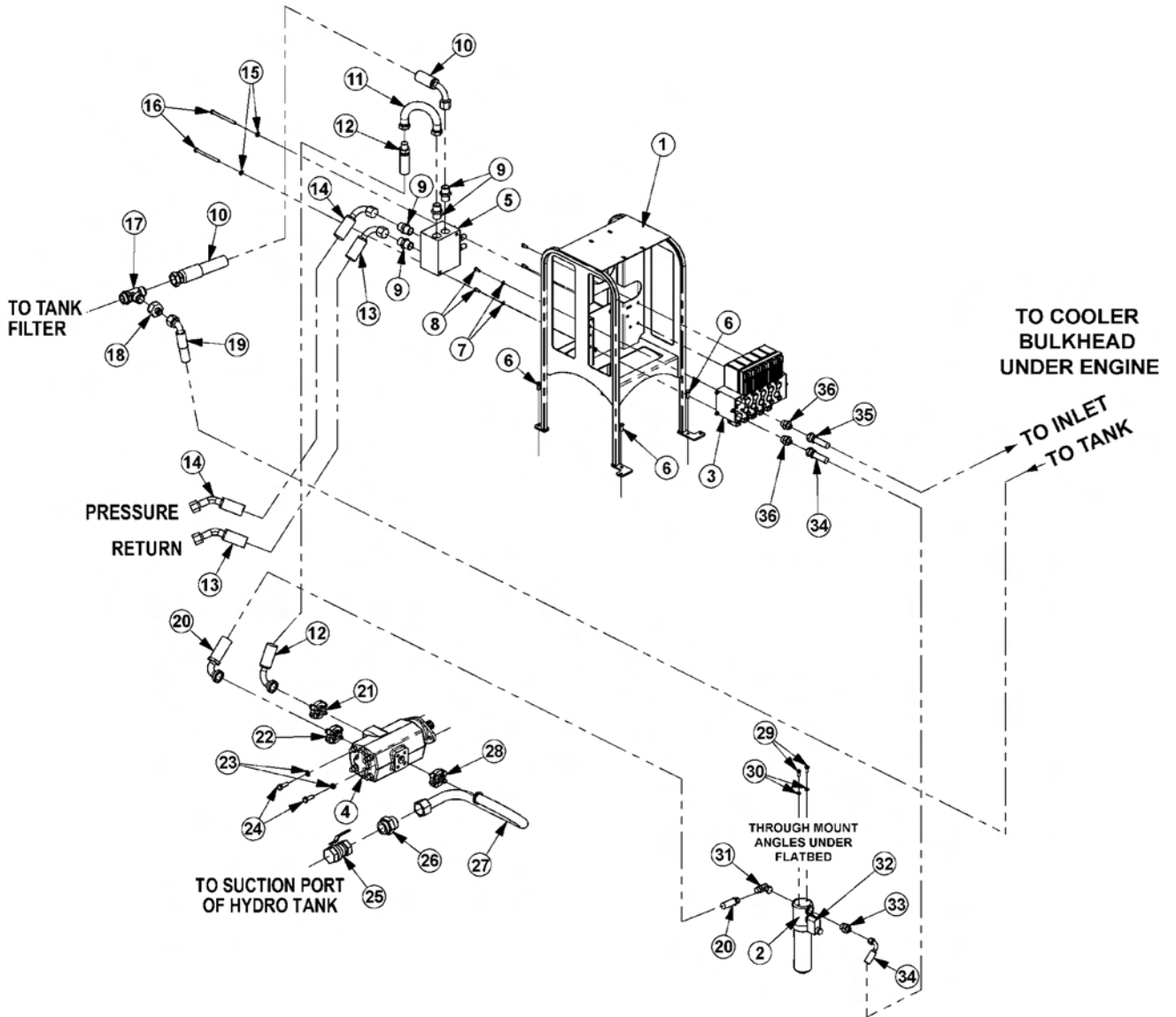

MOWER HYDRAULICS

Continued...

ITEM	PART NO.	QTY.	DESCRIPTION
1	06340037	1	VALVE MOUNT
2	35059	1	FILTER,HYD,HP
---	35285	1	FILTER ELEMENT,HYD,HP
3	06502098	1	VALVE,5 SPOOL,OC
4	35031	1	PUMP
5	06510083	1	VALVE,BRAKE,SOL
6	06530202	4	CAPSCREW,3/8" X 1",SELF TAPPING
7	21987	4	LOCKWASHER,5/16"
8	21579	4	CAPSCREW,5/16" X 3/4",NC
9	33555	4	ADAPTER,1"MOR X 1"MJ
10	06500585	1	HOSE,1" X 44"
11	06506012	1	TUBE,PREFORMED
12	06500584	1	HOSE,1" X 29"
13	06500055	1	HOSE,1" X 100"
14	06500054	1	HOSE,1" X 103"
15	21988	2	LOCKWASHER,3/8"
16	21644	2	CAPSCREW,3/8" X 5",NC
17	34656	1	TEE,RUN,1-1/4"MOR X 1-1/4"MJ X 1-1/4"
18	35280	1	ADAPTER,1-1/4FJ X 3/4"MJ
19	06500587	1	HOSE,3/4" X 96"
20	06500382	1	HOSE,3/4" X 47"
21	TF4852	1	KIT,FLANGE,#20
22	TF4853	1	KIT,FLANGE #16
23	21990	2	LOCKWASHER,1/2"
24	21731	2	CAPSCREW,1/2" X 1-1/2",NC
25	34309	1	BALL VALVE,1-1/2"FOR
26	34710	1	ADAPTER,1-1/2"MOR X 1-1/2"MJ
27	06500051	1	HOSE,1-1/2" X 27"
28	TF4854	1	KIT,FLANGE #24
29	27508	2	CAPSCREW,8MM X 20MM,1.25P
30	6T2619	2	LOCKWASHER,8MM
31	33280	1	ELBOW,3/4"MJ X 3/4"MOR ADJ 90
32	35330	1	RESTRICTION SENDER
33	06503023	1	ADAPTER,3/4"MOR X 3/4"MJ
34	06500496	1	HOSE,3/4" X 50"
35	06500586	1	HOSE,3/4" X 87"
36	06503043	3	ADAPTER,3/4"MOR X 3/4"MJ,45
---	6T3200	2	SPLIT HOSE,6" (NOT SHOWN)
----	6T1823	6	ZIP TIE,14 STRAPS (NOT SHOWN)

TRUCKAT

COOLER HYDRAULICS

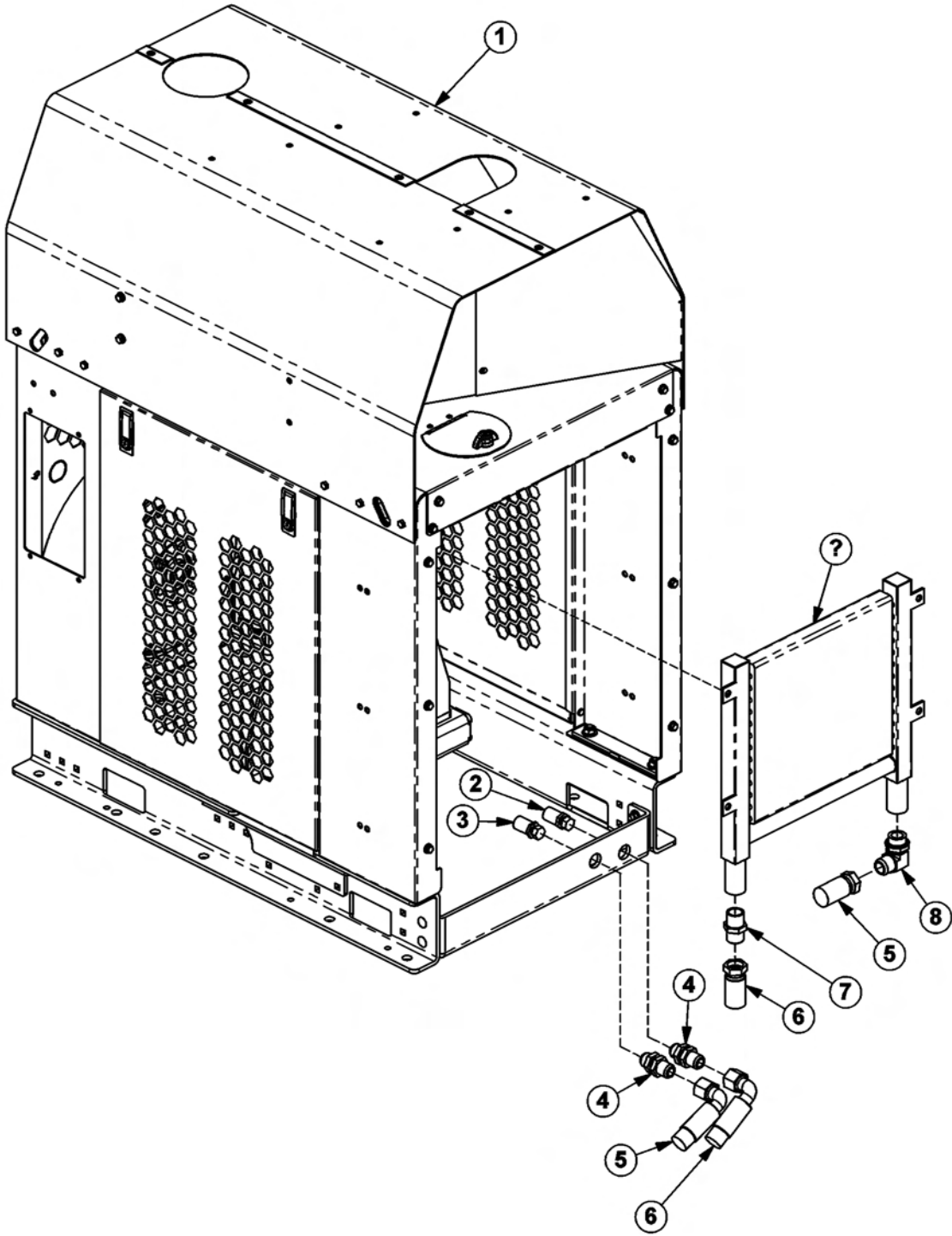

COOLER HYDRAULICS

Continued...

ITEM	PART NO.	QTY.	DESCRIPTION
1	06770051	1	ENCLOSURE,ENGINE
2	06500587	1	HOSE,3/4" X 96"
3	06500586	1	HOSE,3/4" X 87"
4	06503157	2	FITTING,BULKHEAD
5	06500577	1	HOSE,3/4" X 35"
6	06500580	1	HOSE,3/4" X 29"
7	33555	1	ADAPTER,1"MOR X 1"MJ
8	34117	1	ELBOW,1"MOR X 1"MJ,FORGED
9	35012	1	COOLER

COOLER MOUNTING

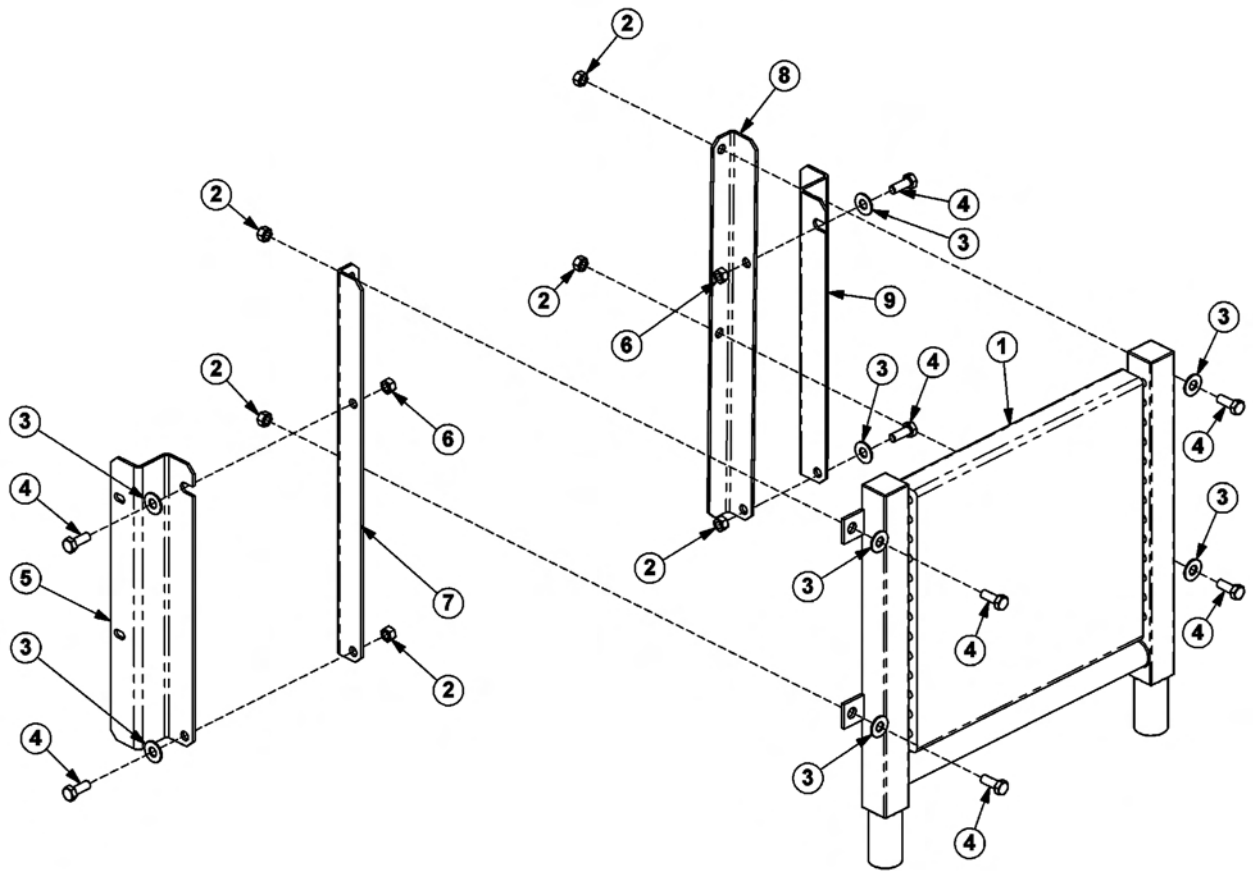

COOLER MOUNTING

Continued...

ITEM	PART NO.	QTY.	DESCRIPTION
1	35012	1	COOLER
2	21627	6	NYLOCK NUT,3/8",NC
3	22016	8	FLATWASHER,3/8"
4	21629	8	CAPSCREW,3/8" X 1",NC
5	-----	-	RIGHT HAND ENGINE BRACKET
6	21625	2	HEX NUT,3/8",NC
7	06411258	1	MOUNT,COOLER,RH
8	06411257	1	MOUNT,COOLER,LH
9	-----	-	LEFT HAND ENGINE BRACKET

JOYSTICK AND SWITCHBOX MOUNT

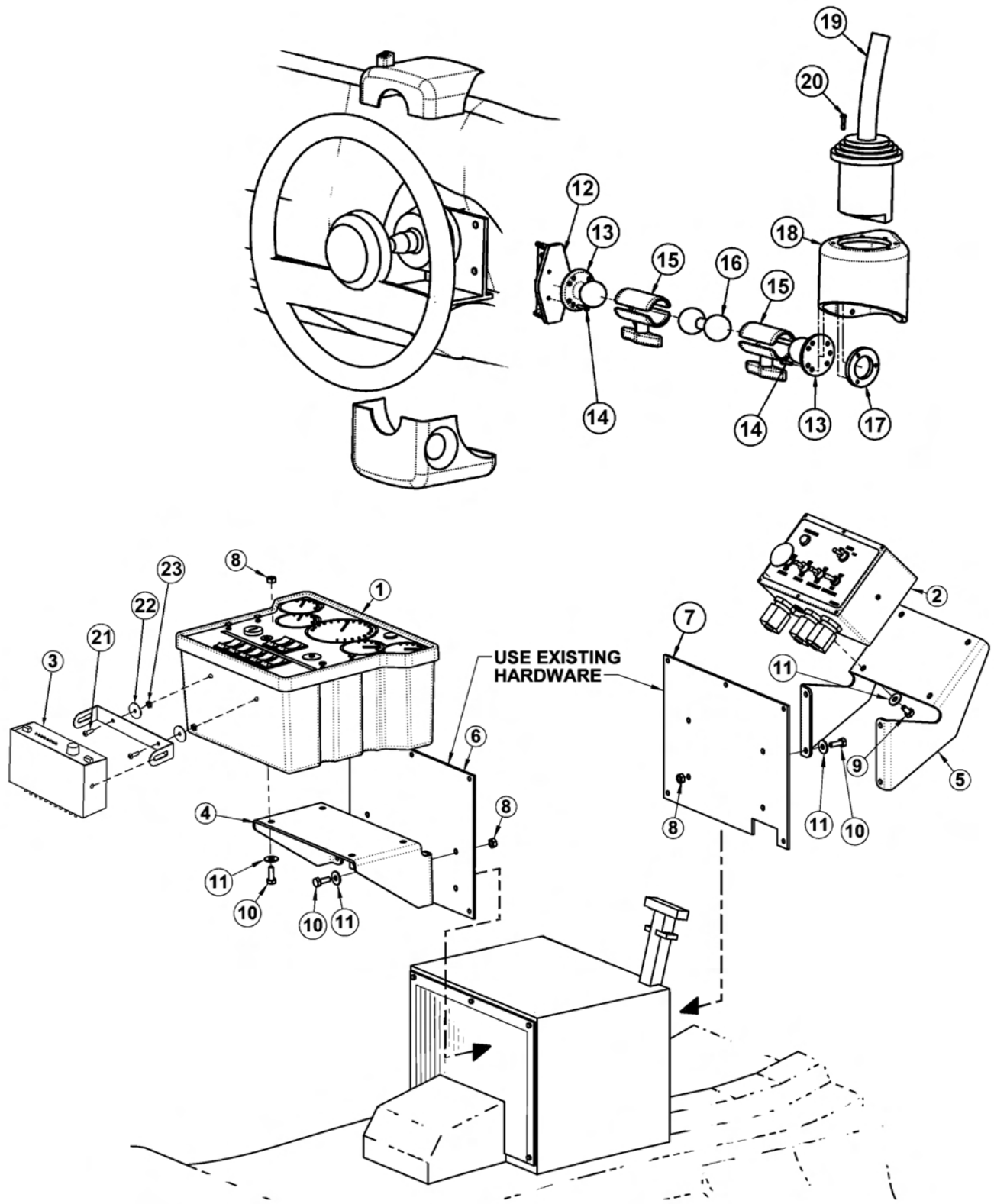

JOYSTICK AND SWITCHBOX MOUNT

Continued...

ITEM	PART NO.	QTY.	DESCRIPTION
1	-----	-	AUX ENG CONSOLE (NOT FOR SALE)
2	06510103	1	SWITCHBOX
3	-----	-	ECCO LIGHT CONTROLLER (PART OF LIGHT BAR OPTION)
4	06410744	1	MNT,CONSOLE
5	06410745	1	MNT,SWBX
6	-----	-	CONSOLE BACK PANEL (NOT FOR SALE)
7	-----	-	CONSOLE FRONT PANEL (NOT FOR SALE)
8	21527	12	NYLOCK NUT,1/4",NC
9	21528	4	CAPSCREW,1/4" X 1/2",NC
10	21529	12	CAPSCREW,1/4" X 3/4",NC
11	22014	16	FLATWASHER,1/4"
12	06340036	1	MNT,JYSTK
13	06520019	2	MOUNT,RAM,BALL,1-1/2"
14	32990	6	SCREW,MCHN,10-32 X 3/4"
15	06520042	2	MOUNT,RAM,ARM,1-1/2" X 2-3/4"
16	06520290	1	MOUNT,RAM,BALL,DBL,1-1/2"
17	06400882	1	RING,BOLT,MNT,JYSTK
18	06770022	1	CAN,JYSTK
19	33691	1	JOYSTICK
20	32829	4	SCREW
21	32990	2	MACHINE SCREW,#10-32 X 5/8"
22	34508	2	WASHER,#10
23	06532001	2	NYLOCK NUT,#10-32

ENGINE CONSOLE BREAKDOWN

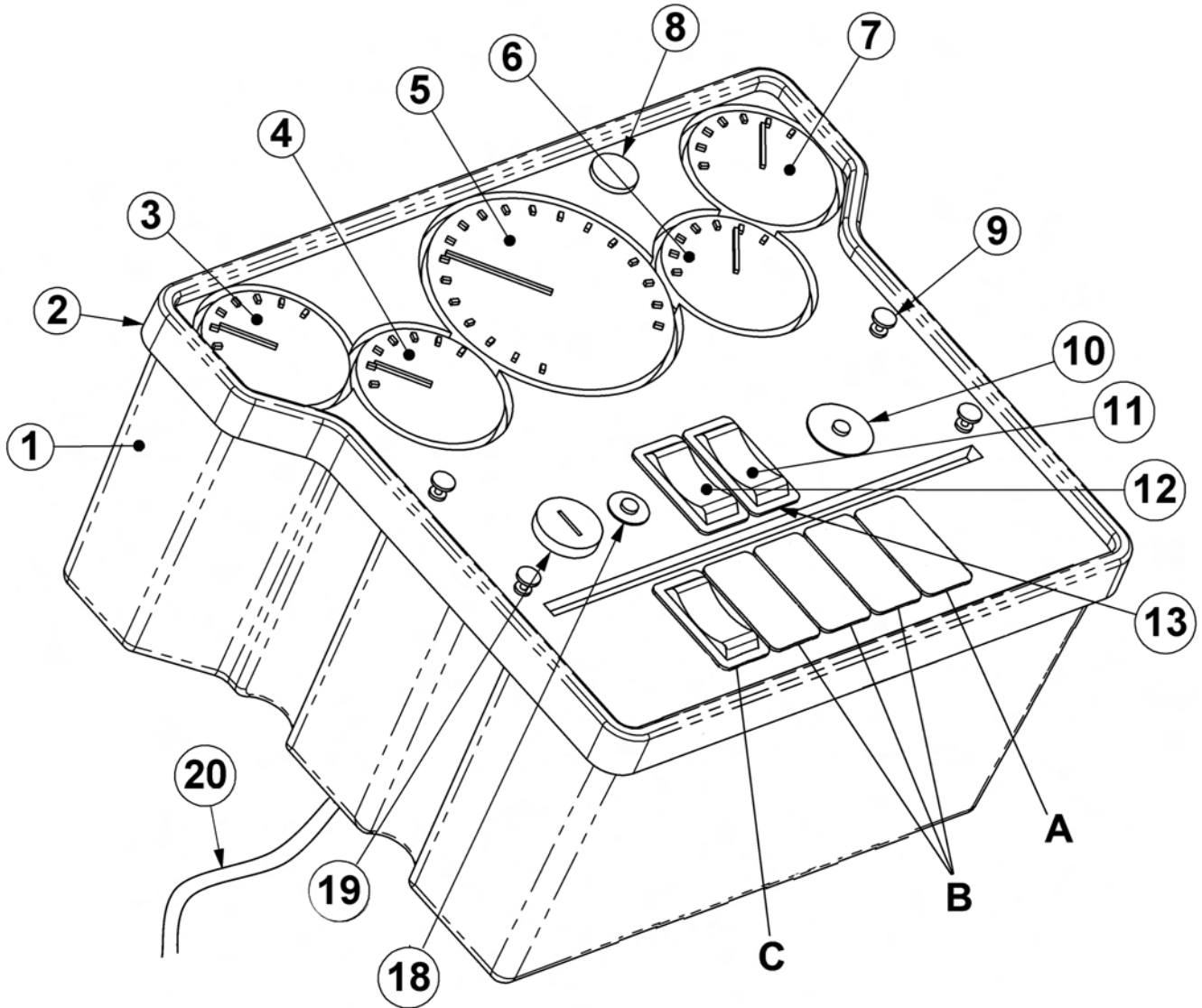

- A - 13 14 16
 B - 14 16 21
 C - 13 15 16 17

ENGINE CONSOLE BREAKDOWN

Continued...

ITEM	PART NO.	QTY.	DESCRIPTION
1	+26558	1	CONSOLE,BOTTOM
2	+26557	1	CONSOLE, TOP
3	06510203	1	GUAGE,TEMP,H2O
4	06510204	1	GUAGE,PRESS,ENG OIL
5	06510205	1	GUAGE,TACH,HOUR
6	06510206	1	GUAGE,VOLT
7	06510207	1	GUAGE,TEMP,HYDRO
8	06510208	1	LIGHT,IND,FILTER
9	+26635	2	KNURLED HEAD SCREW
10	06510033	1	RELAY,SHUTDOWN
11	+27262	1	MOMENTARY SWITCH
12	06510210	1	SWITCH,MOM,PREHEAT
13	+27267	4	SWITCH END MOUNT,CARLING
14	+27265	4	BLANKING PLUG
15	+27234	1	SWITCH ACTUATOR,BEACON
16	+27264	5	SWITCH CONNECTOR,CARLING
17	+27261	1	SWITCH,SPST O-F,ROCKER
18	06510211	1	BREAKER,3A
19	06510212	1	SWITCH,KEY
20	06510213	1	HARNES
21	+27266	3	MODULAR MOUNT,MIDDLE

FIRE EXTINGUISHER MOUNT

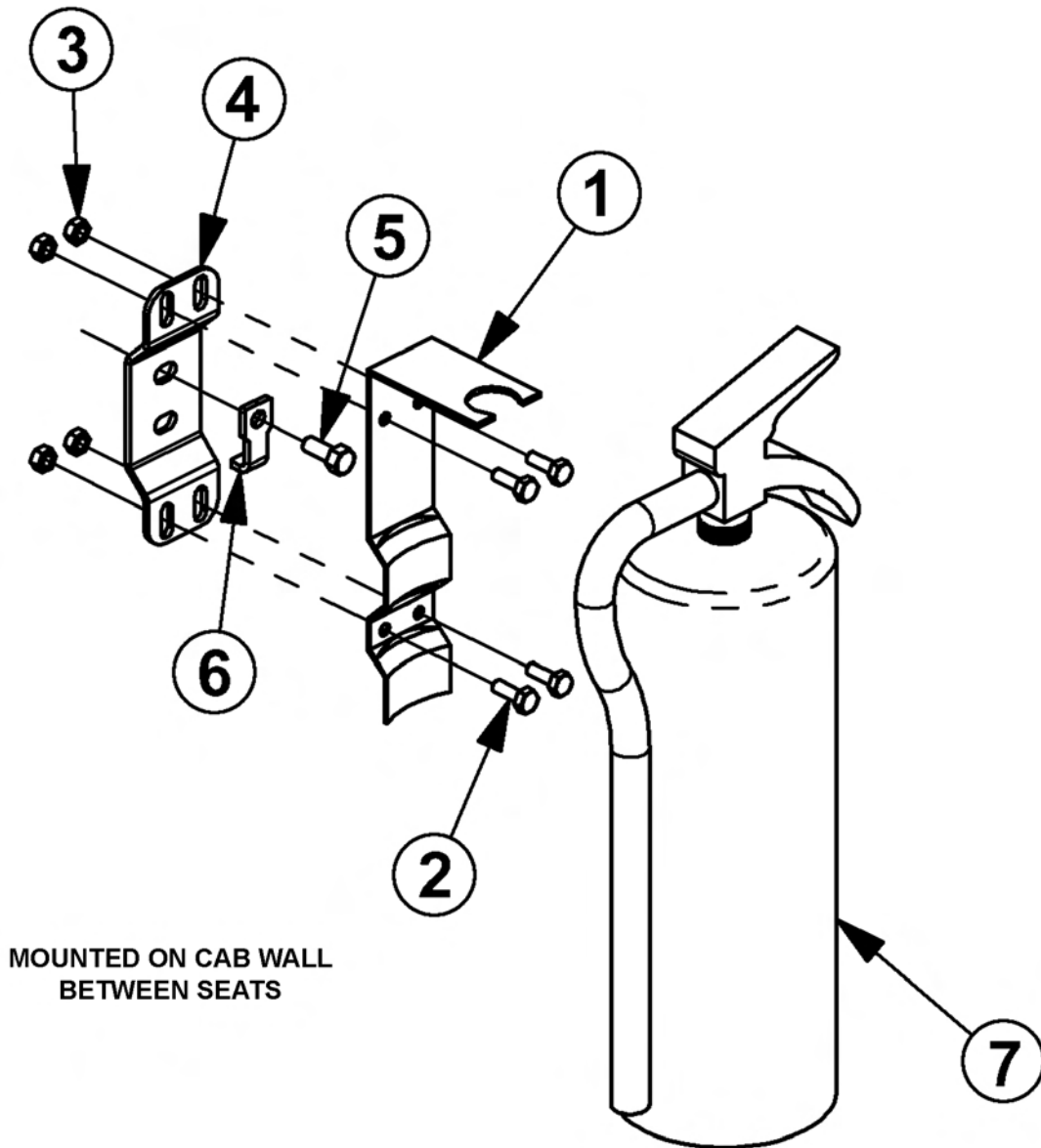

ITEM	PART NO.	QTY.	DESCRIPTION
1	32212	1	FIRE EXTINGUISHER BRACKET
2	21529	4	CAPSCREW, 1/4" X 3/4", NC
3	21527	4	HEX NUT, NYLOCK, 1/4", NC
4	06410174	1	MNT, FIRE EXTINGUISHER
5	27508	2	CAPSCREW, 8MM X 20MM, 1.25P
6	06410636	1	KEEPER, MNT, FIRE EXT
7	32212	1	FIRE EXTINGUISHER, 5#, ABC

HANDRAIL

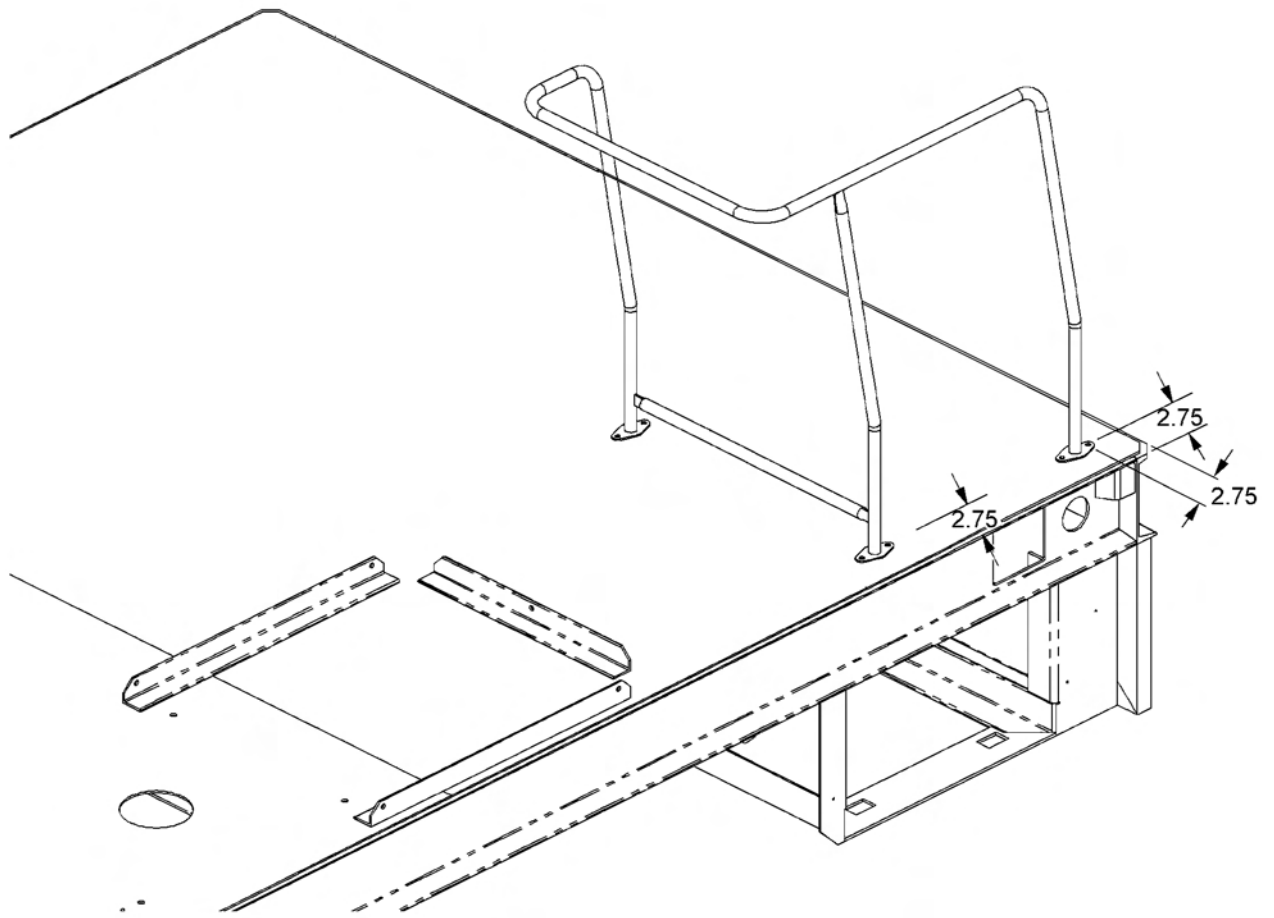

SAFETY SWITCHES

DOOR SWITCH

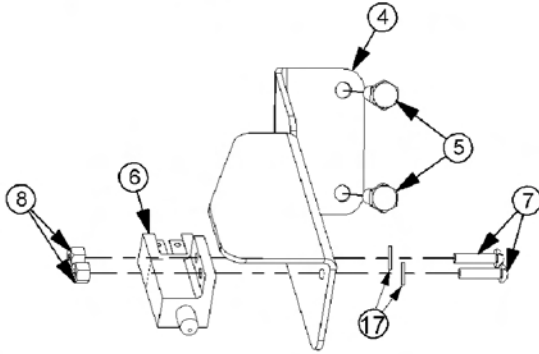

LIMIT SWITCH

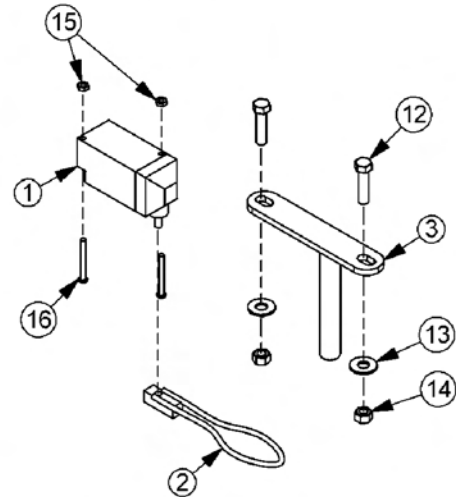

BACKUP ALARM

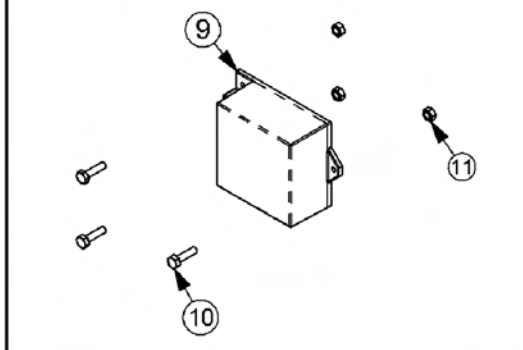

SAFETY SWITCHES

Continued...

ITEM	PART NO.	QTY.	DESCRIPTION
1	35186	1	SAFETY SWITCH,SWIVEL
2	35221	1	LOOP,LIMIT SWITCH
3	35181	1	SWITCH POST,SWIVEL
4	06410076	1	BRKT,DOOR SWITCH
5	06530204	2	CAPSCREW,1/4" X 1",SELF TAPPING
6	35184	1	SAFETY SWITCH,DOOR
7	32359	2	SCREW,MACHINE,8-32 X 3/4"
8	6T3952	2	NYLOCK NUT,8-32
9	6T3922	1	ALARM,BACKUP,ELECTRIC
10	27260	3	SCREW,MACHINE,10-24 X 1"
11	24890	3	NYLOCK NUT,10-24
12	21632	2	CAPSCREW,3/8" X 1-1/2",NC
13	22016	2	FLATWASHER,3/8"
14	21627	2	NYLOCK NUT,3/8",NC
15	24890	2	NYLOCK NUT,10-24
16	27594	2	SCREW,MACHINE,10-24 X 2"
17	6T3853	2	FLATWASHER,#8

TRUCKAT

SAFETY SCREEN ASSEMBLY

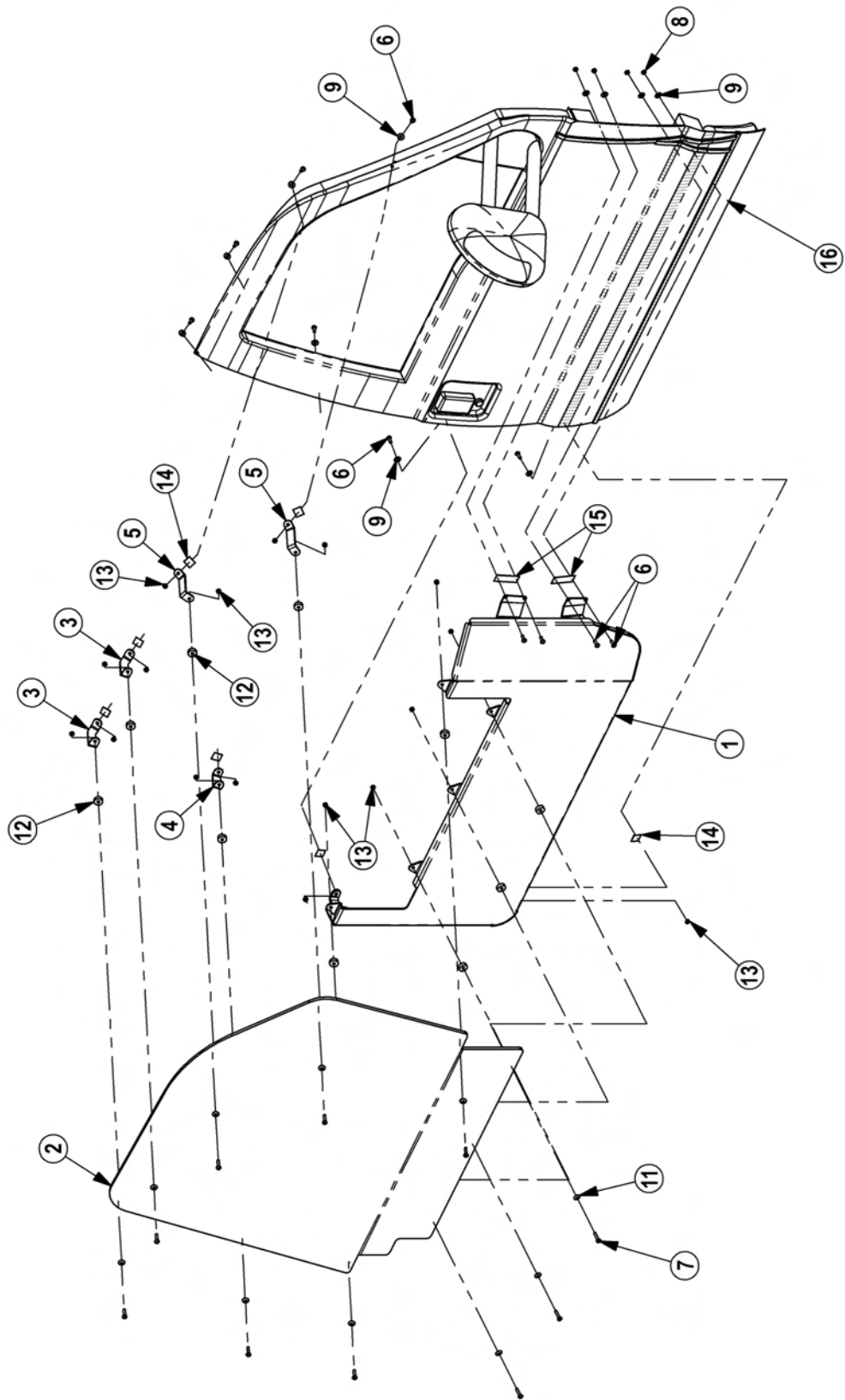

SAFETY SCREEN ASSEMBLY

Continued...

ITEM	PART NO.	QTY.	DESCRIPTION
1	06330018	1	SAFETY SCREEN,FORMED
2	06490022	1	POLYCARB,FORMED
3	06410091	2	MOUNTING BRACKET,3
4	06410090	1	MOUNTING BRACKET,2
5	06410089	2	MOUNTING BRACKET,1
6	35067	11	MACH SCW,1/4" X 3/4",NC,SS
7	35235	10	MACH SCW,1/4" X 1-1/2",NC,SS
8	35066	4	NYLOCK NUT,1/4",NC,SS
9	35326	11	FLATWASHER,1/4,SS
11	06537001	10	WASHER,RUBBERIZED,CONICAL
12	06537000	10	WASHER,NEOPRENE
13	35066	17	NYLOCK NUT,1/4",NC,SS
14	06497000	7	PAD,1" X 1"
15	06497001	2	PAD,1" X 3"
16	-----	-	CAB DOOR

NOTES

DECK STOP - TRB50



1. SWIVEL BOOM TO FULL "AFT". LOCATE INBOARD STOW POSITION OF MOWER HEAD ON FLATBED.
2. WITH MOWER LIFTED SLIGHTLY, LOCATE ITEM 2 UNDER FRONT LEFT HAND CORNER OF MOWER SKID SHOE.

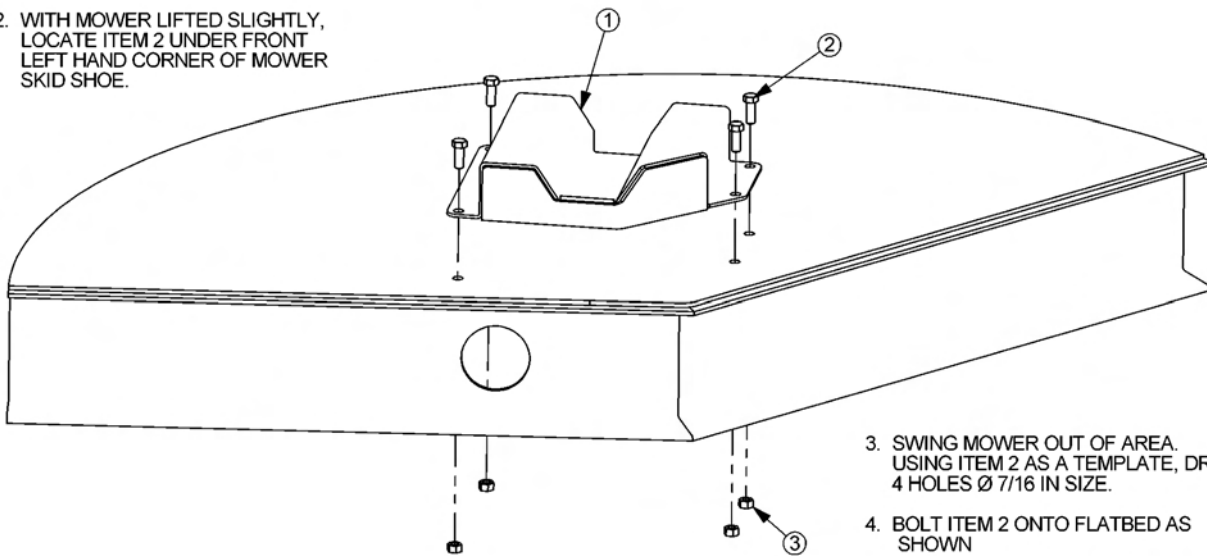

3. SWING MOWER OUT OF AREA. USING ITEM 2 AS A TEMPLATE, DRILL 4 HOLES \varnothing 7/16 IN SIZE.
4. BOLT ITEM 2 ONTO FLATBED AS SHOWN

ITEM	PART NO.	QTY.	DESCRIPTION
1	35078	1	DECK STOP
2	21630	4	CAPSCREW, 3/8" X 1", NC
3	21627	4	NYLOCK NUT, 3/8", NC

DECK STOP - TBF50 & TBF63

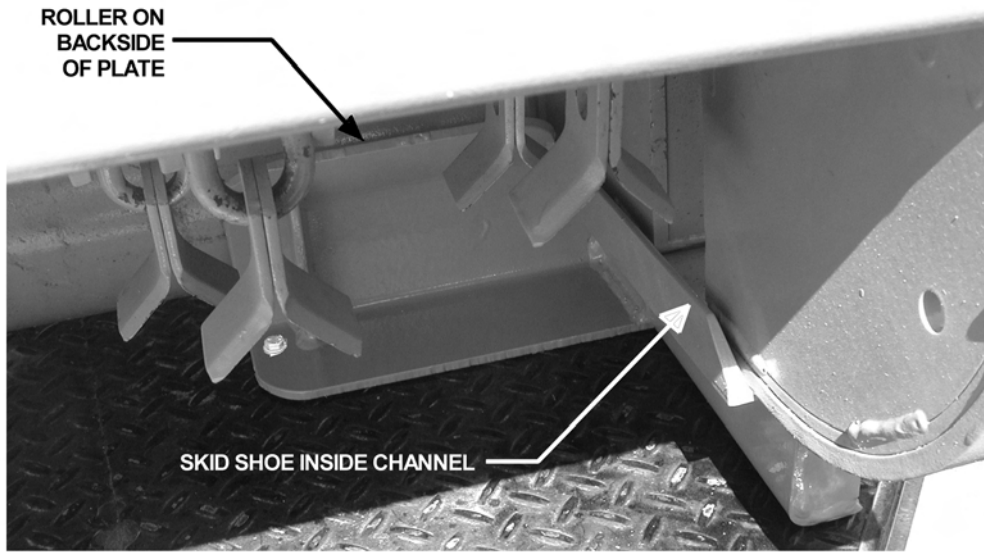

1. LOCATE DECK STOP WITH MOWER HEAD AND MARK HOLE LOCATIONS.
2. MAKE SURE HOLES ARE NOT THROUGH OR TOO CLOSE TO ANY STRUCTURES UNDER DECK.
3. DRILL HOLES WITH 13/32" BIT.
4. MOUNT 35324 WITH INCLUDED HARDWARE.

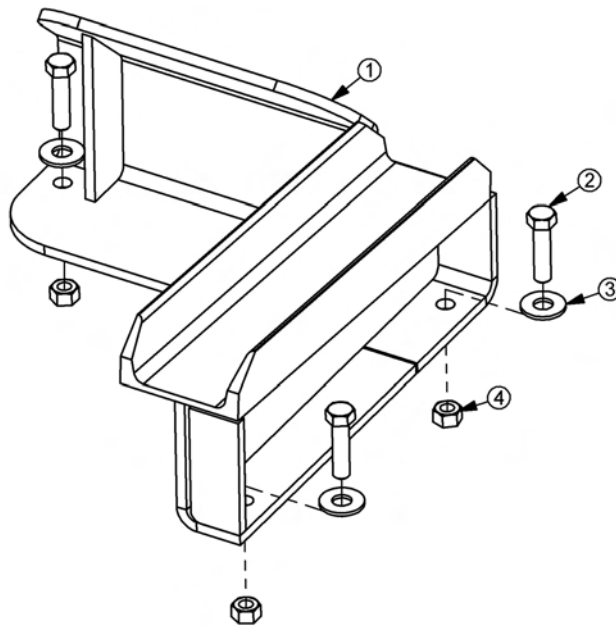

ITEM	PART NO.	QTY.	DESCRIPTION
1	35324	1	DECK STOP,63" TBF
2	21632	3	CAPSCREW,3/8" X 1-1/2",NC
3	22016	3	FLATWASHER,3/8"
4	21627	3	NYLOCK NUT,3/8",NC

HEADACHE RACK ASSEMBLY

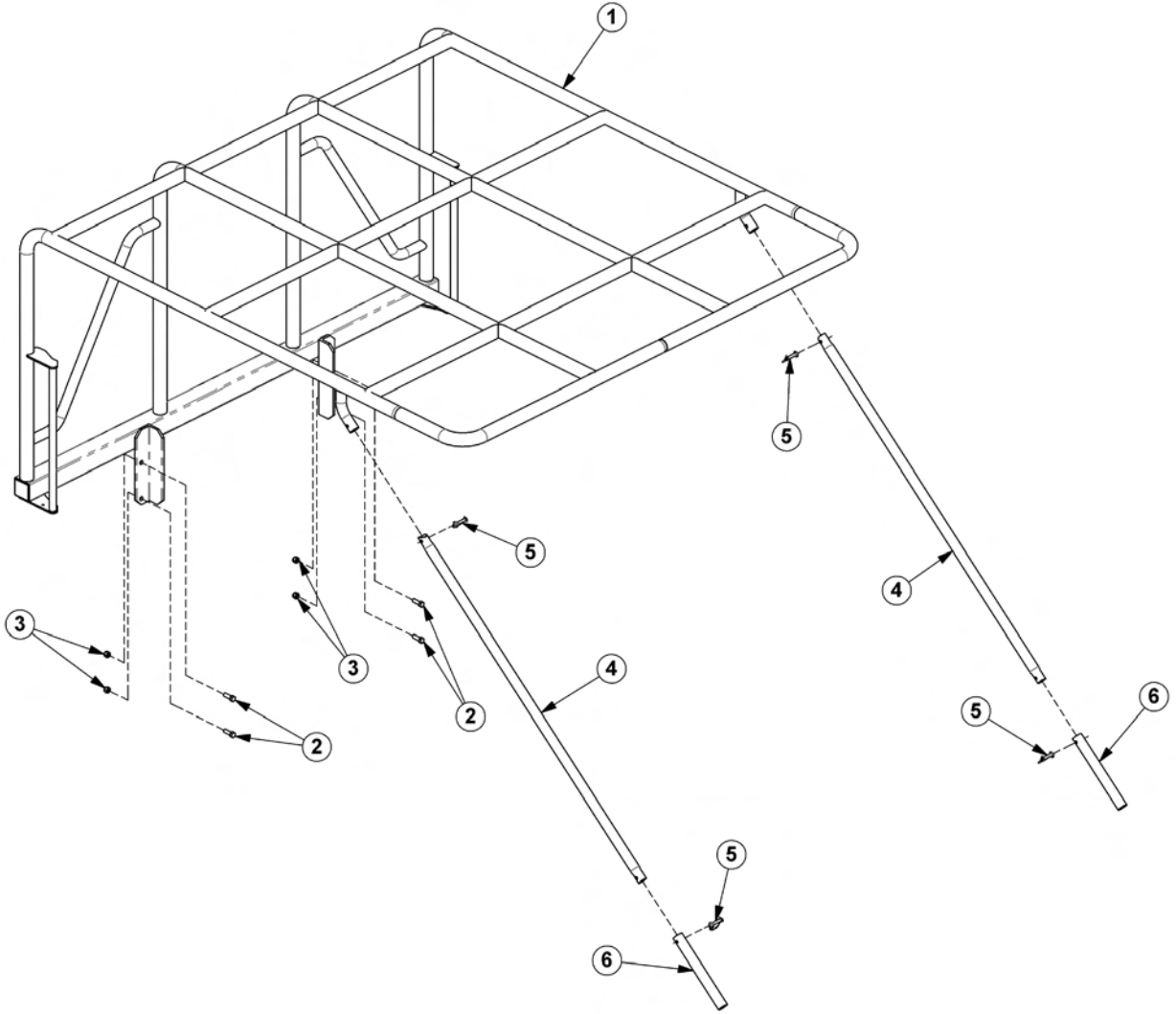

ITEM	PART NO.	QTY.	DESCRIPTION
1	06330003	1	HEADACHE RACK
2	21731	4	CAPSCREW, 1/2" X 1-1/2", NC
3	21727	4	NYLOCK NUT, 1/2", NC
4	06430008	2	BRACE, HDCH RCK
5	33906	4	PIN, LINCH, 3/8" X 2", LOOP
6	-----	-	BUMPER MOUNT *REFER TO BUMPER ASSY PAGE

LIGHT BAR OPTION

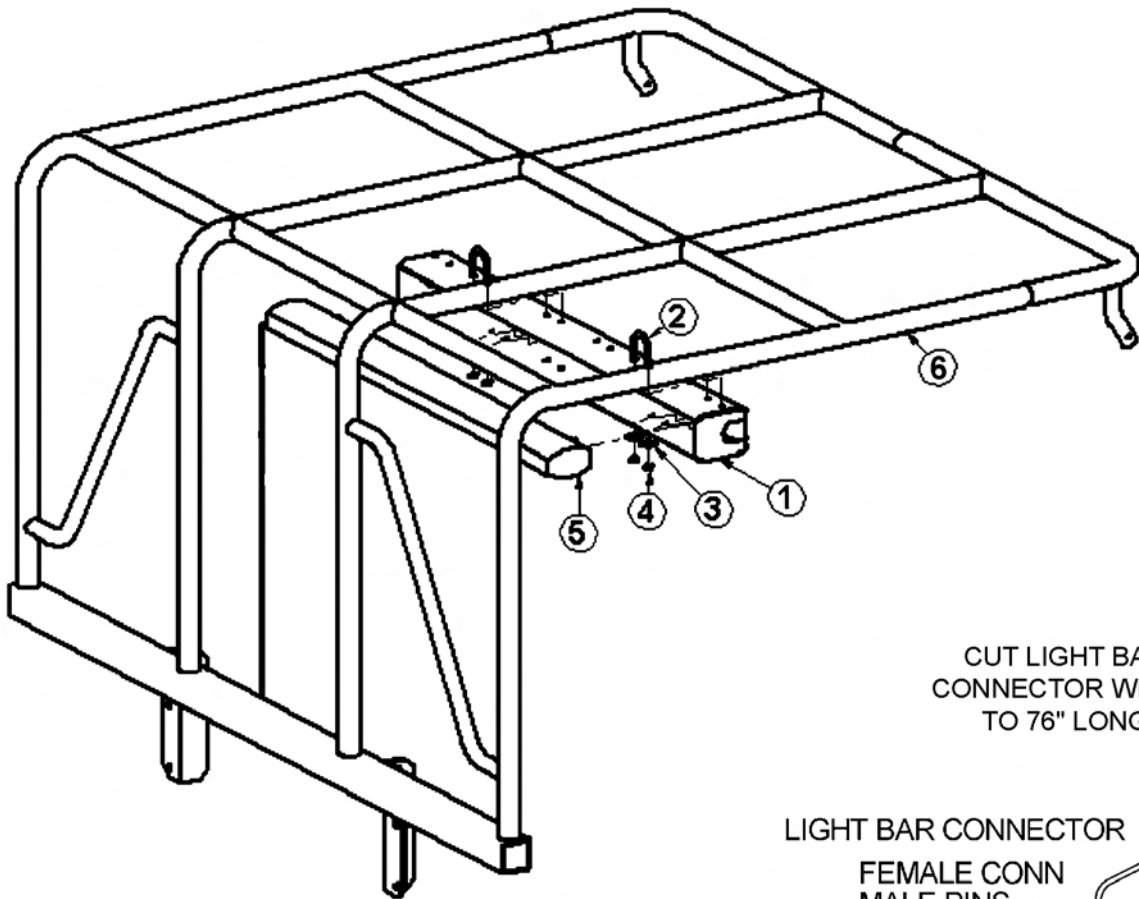

CUT LIGHT BAR
CONNECTOR WIRES
TO 76" LONG

CONNECTOR # 1
 YELLOW WIRE - PIN # A
 ORANGE WIRE - PIN # B
 BLUE WIRE - PIN # C
 GRAY WIRE - PIN # D
 WHITE WIRE - PIN # E
 EMPTY - PIN # F

CONNECTOR # 2
 GREEN WIRE - PIN # A
 RED WIRE - PIN # B
 WHITE WIRE - PIN # C
 BROWN WIRE - PIN # D
 PURPLE WIRE - PIN # E
 EMPTY - PIN # F

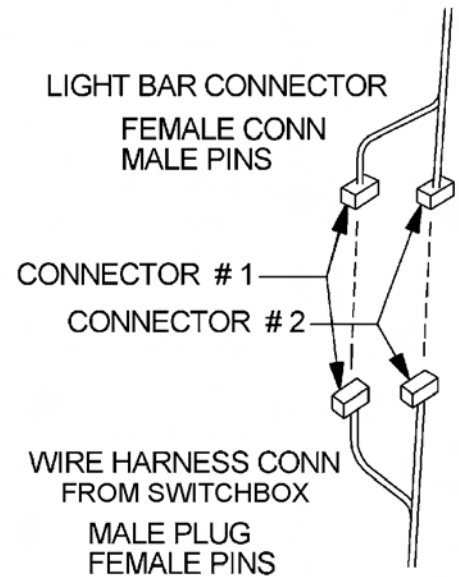

ITEM	PART NO.	QTY.	DESCRIPTION
1	06330008	2	MNT,LIGHT BAR
2	27602	2	U-BOLT,3/8" X 2",NC
3	6T2615	4	WASHER,FENDER,3/8"
4	21627	4	NYLOCK NUT,3/8",NC
5	35149	1	ECO LIGHT
6	-----	-	HEADACHE RACK *REFER TO HEADACHE RACK PAGE

SPARE TIRE OPTION

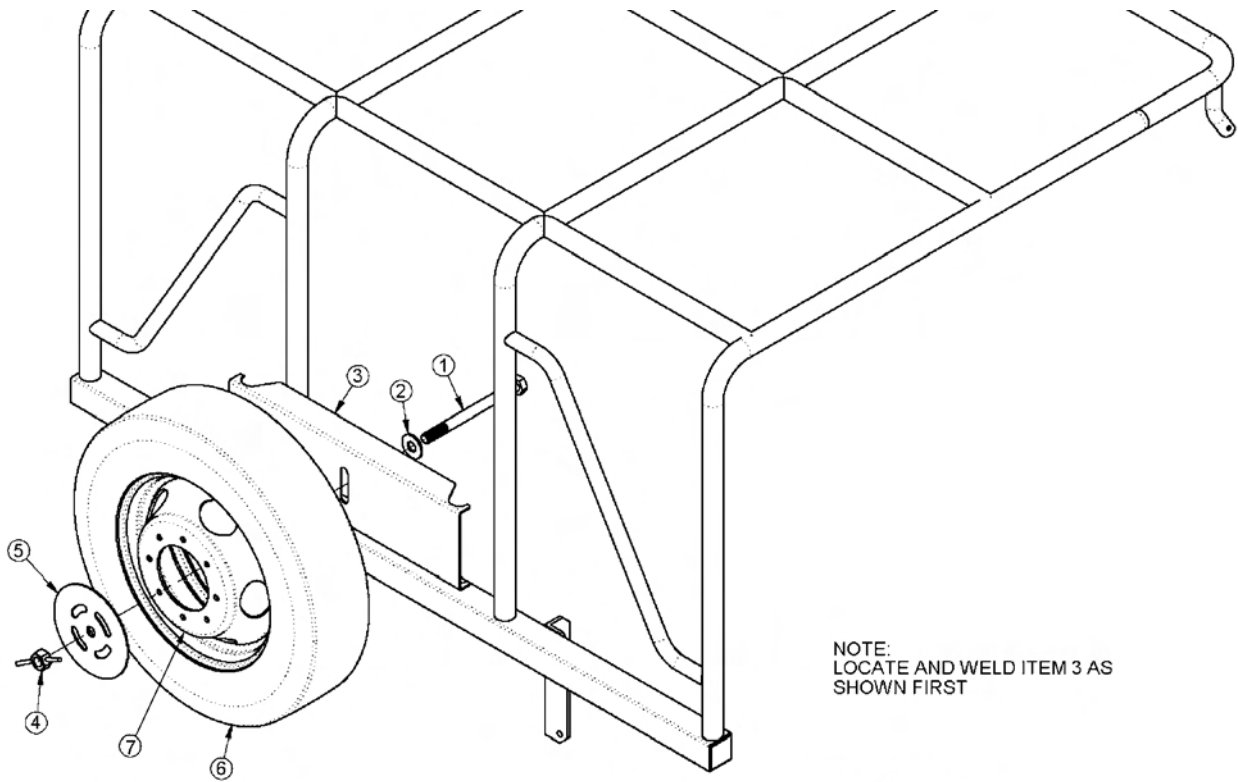

NOTE:
LOCATE AND WELD ITEM 3 AS
SHOWN FIRST

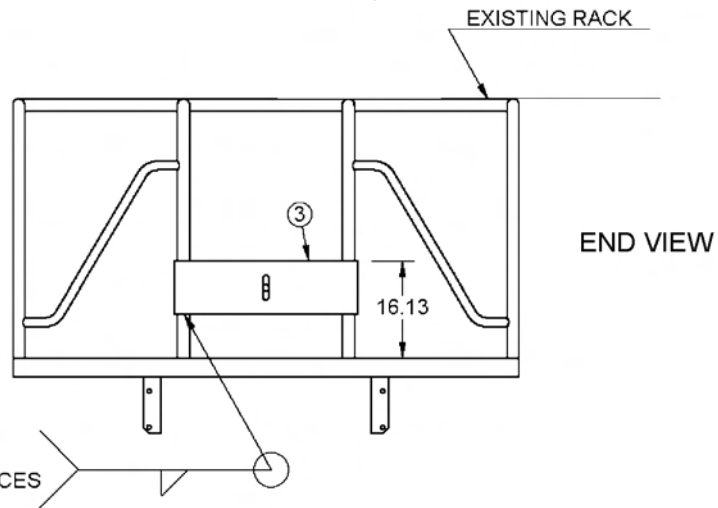

ITEM	PART NO.	QTY.	DESCRIPTION
1	06535001	1	CAPSCREW,1" X 12",NC
2	22023	1	FLATWASHER,1"
3	06370023	1	RECEIVER,TIRE
4	06370024	1	WINGNUT
5	06370025	1	INDEX,TIRE
6	34808	1	TIRE
7	06520046	1	RIM
---	06520044	1	PADLOCK (NOT SHOWN)

2 FOOT TOOLBOX OPTION

TRUCKAT FRONT LEFT HAND FLATBED CORNER

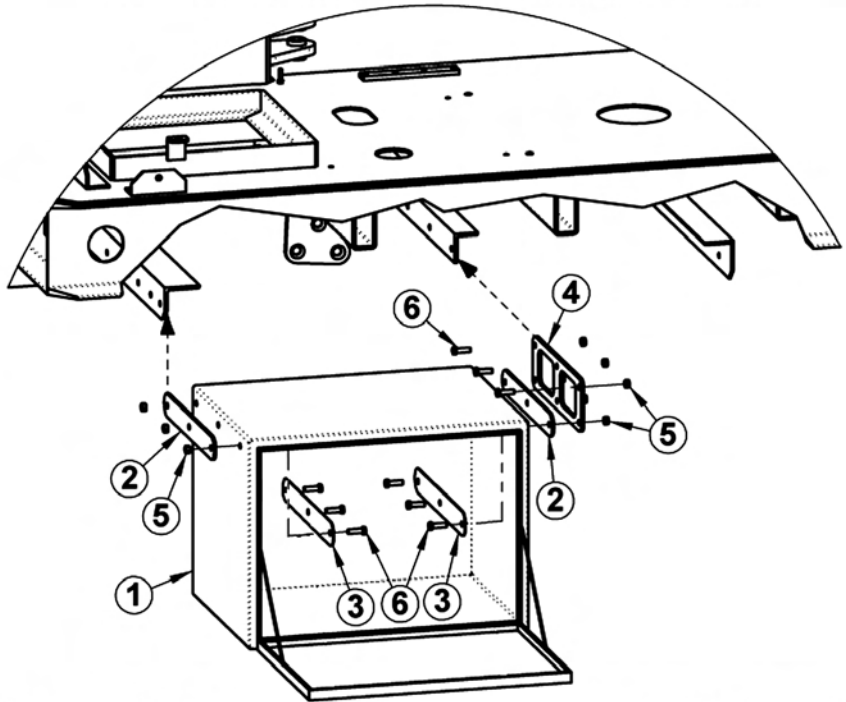
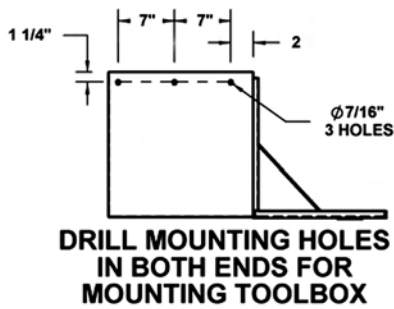

**INSTALL (1) OF ITEM 2 BETWEEN TOOLBOX AND MOUNTING BRACKET
INSTALL (1) OF ITEM 2 BETWEEN TOOLBOX AND ITEM 4**

ITEM	PART NO.	QTY.	DESCRIPTION
1	35319	1	TOOLBOX,18" X 18" X 24"
2	35318	2	RUBBER STRAP
3	35320	2	STRAP,INNER
4	06400940	1	MNT,TOOLBOX,TRUCKAT
5	21627	9	NYLOCK NUT,3/8",NC
6	21631	9	CAPSCREW,3/8" X 1-1/4",NC

4 FOOT TOOLBOX OPTION

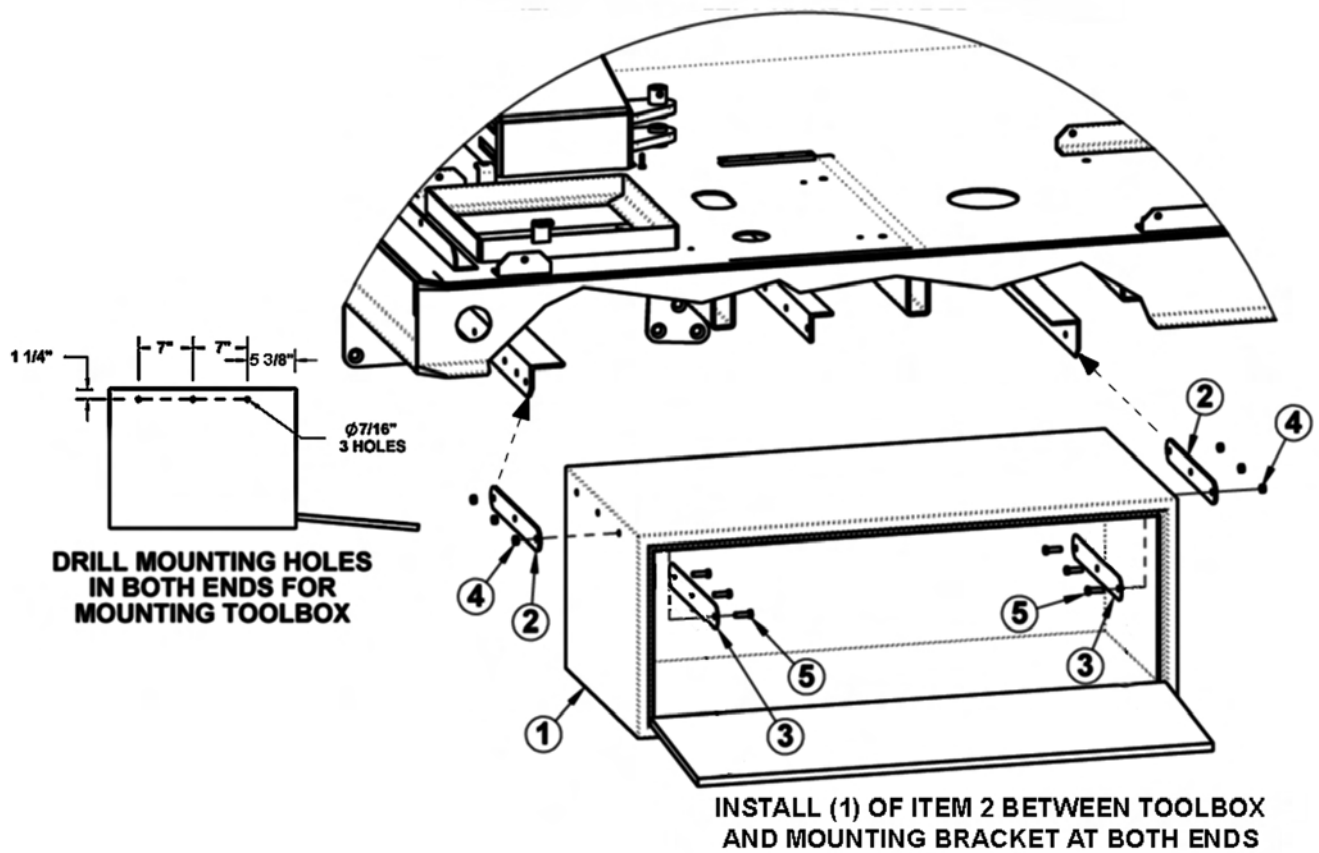

ITEM	PART NO.	QTY.	DESCRIPTION
1	06520286	1	TOOLBOX,18" X 18" X 48"
2	35318	2	RUBBER STRAP
3	35320	2	STRAP,INNER
4	21627	6	NYLOCK NUT,3/8",NC
5	21631	6	CAPSCREW,3/8" X 1-1/4",NC

ELECTRONIC PROPORTIONAL LIFT VALVE BREAKDOWN

**REWORK VALVE PN 06502096
TO MAKE 06502098**

X = PN 33943

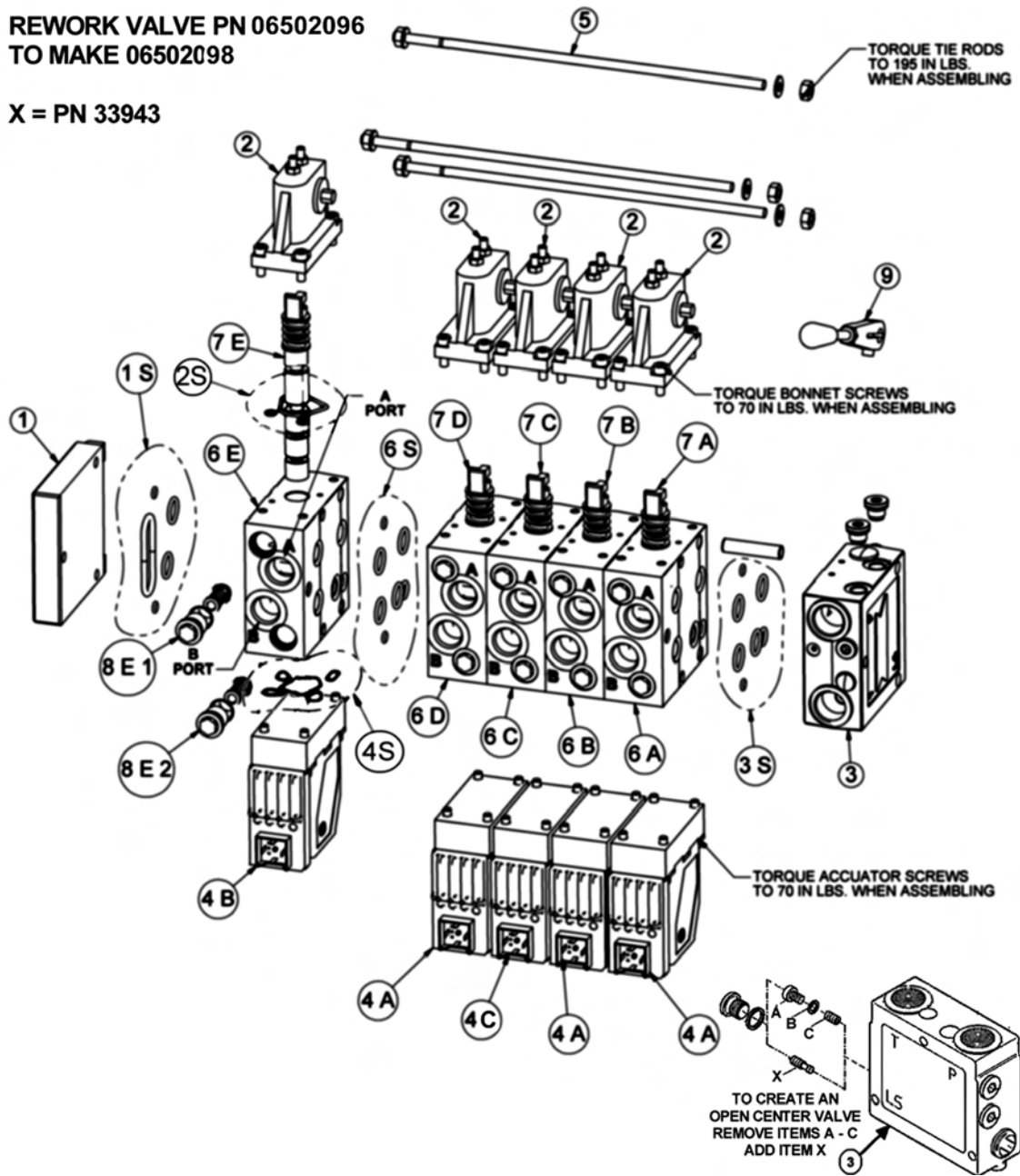

ITEM	PART NO.	QTY.	DESCRIPTION
---	06502098	-	VLV,5SP,32PVG
1	06502074	1	END PLATE
1S	06505013	1	END PLATE SEAL KIT
2	-----	5	BONNET
2S	06502073	1	BONNET SEAL KIT
2A	06502073	1	MAIN BOOM BONNET
2B	06502073	1	SECONDARY BOOM BONNET
2C	06502073	1	DECK ROLL BONNET

ELECTRONIC PROPORTIONAL LIFT VALVE BREAKDOWN

Continued...

ITEM	PART NO.	QTY.	DESCRIPTION
2D	06502073	1	BOOM SWIVEL BONNET
2E	06502073	1	DECK SHIELD BONNET
3	34308	1	INLET SECTION
3S	06505013	1	INLET SECTION SEAL KIT
4	-----	5	ELECTRONIC ACCUATOR
4A	06502101	1	MAIN BOOM ELECTRONIC ACCUATOR
4B	06502101	1	SECONDARY BOOM ELECTRONIC ACCUATOR
4C	06502100	1	DECK ROLL ELECTRONIC ACCUATOR
4D	06502101	1	BOOM SWIVEL ELECTRONIC ACCUATOR
4E	06502099	1	DECK SHIELD ELECTRONIC ACCUATOR
5	42202	1	TIE-BOLT KIT
6	-----	5	SECTION
6S	06505013	1	SECTION SEAL KIT
6A	42698	1	MAIN BOOM SECTION
6B	42698	1	SEC BOOM SECTION
6C	06502076	1	DECK ROLL SECTION
6D	42698	1	BOOM SWIVEL SECTION
6E	06502077	1	SHIELD SECTION
7	-----	5	SPOOL
7A	42697	1	MAIN BOOM SPOOL
7B	42697	1	SEC BOOM SPOOL
7C	4242106	1	DECK ROLL SPOOL
7D	06502073	1	BOOM SWIVEL SPOOL
7E	42201	1	DECK SHIELD SPOOL
8	-----	10	ANTI CAV/SHOCK RELIEF
8A1	42650	1	MAIN BOOM A PORT RELIEF
8A2	06502069	1	MAIN BOOM B PORT RELIEF
8B1	42650	1	SEC BOOM A PORT RELIEF
8B2	42295	1	SEC BOOM B PORT RELIEF
8C1	42296	1	DECK ROLL A PORT RELIEF
8C2	42295	1	DECK ROLL B PORT RELIEF
8D1	42295	1	BOOM SWIVEL A PORT RELIEF
8D2	42295	1	BOOM SWIVEL B PORT RELIEF
8E1	06502069	1	DECK SHIELD A PORT RELIEF
8E2	06502069	1	DECK SHIELD B PORT RELIEF
9	33459	1	HANDLE

TRUCKAT

PUMP BREAKDOWN

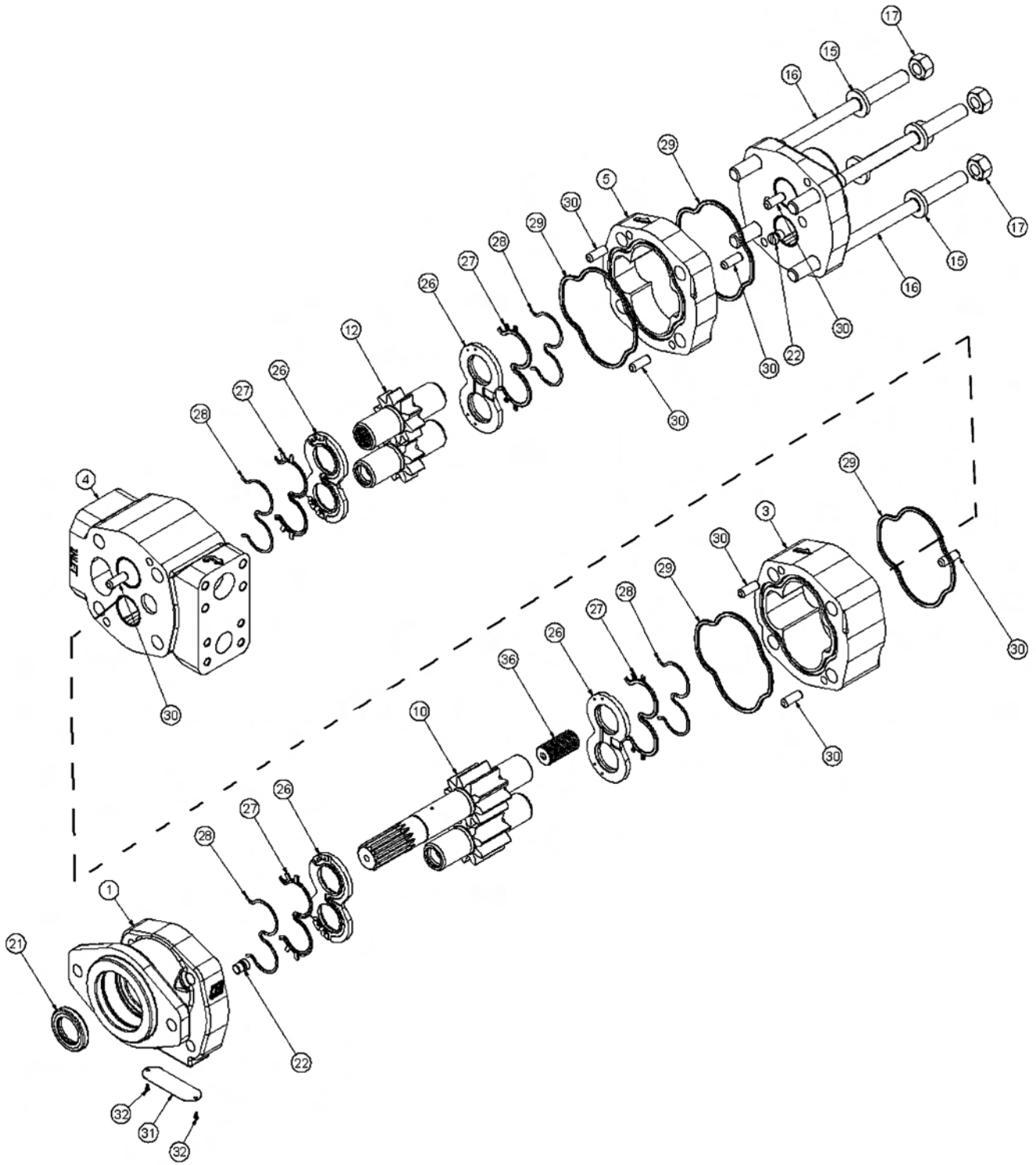

PUMP BREAKDOWN

Continued...

ITEM	PART NO.	QTY.	DESCRIPTION
---	35031	-	PUMP,P350
1	06504081	1	HOUSING,SEC
2	06504082	1	HOUSING,PEC
3	02965092	1	HOUSING,GEAR
4	06504083	1	HOUSING,BEARING CARRIER
5	06504084	1	HOUSING,GEAR
10	22771	1	SET,GEAR SHAFT
12	06504085	1	GEAR,SET
15	02961917	4	WASHER
16	06504086	4	STUD
17	06504073	4	NUT,HEX
21	22765	1	SEAL,LIP
22	06504087	2	PLUG
26	02965611	4	THRPL
27	06504074	4	SEAL,CHAN
28	06504075	4	SEAL,BK-UP
29	06504076	4	SEAL,SQ-R
30	02961924	8	PIN,DOWEL
31	06504077	1	NAME PLATE
32	06504078	2	SCREW,DRIVE
36	06504079	1	SFT,CONN
---	06504080	1	SEAL KIT

AIR RIDE PARTS LIST - AIR BAG ASSY

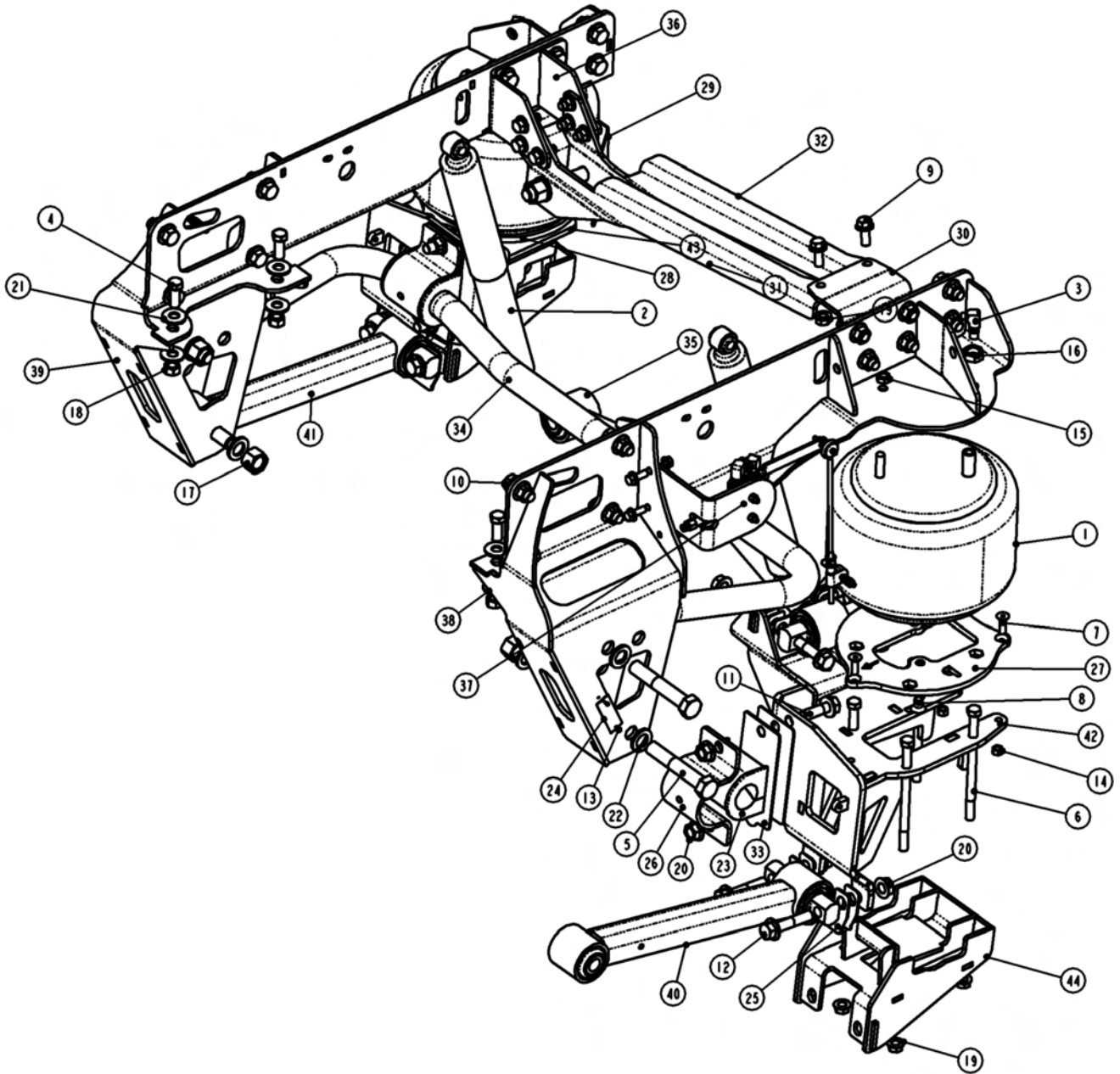

ITEM	PART NO.	QTY.	DESCRIPTION
1	06520287	2	SPRING-AIR
2	12100529	2	SHOCK ABSORBER
3	1302-5091	2	ELBOW, 1/4 TB 1/4 M-NPT, PUSH-IN DOT
4	14041812	4	9/16 X 1 1/2 UNF HEX CAP SCR (GR 8)

AIR RIDE PARTS LIST - AIR BAG ASSY

Continued...

ITEM	PART NO.	QTY.	DESCRIPTION
5	14062226	5	HEX CAP SCREW, M22 X 2.5 X 130, CLASS 10.9, O&P
6	140B-1664	8	1/2 X 8 UNC HEX CAP SCR (GR 8) O&P
7	1417-1210	6	3/8 X 1 1/4 UNC SOC FLAT CSK HD CAP SCREW
8	1417-1606	4	1/2 X 3/4 UNC SOC FLAT CSK HD CAP SCREW
9	141A-1610	8	1/2 X 1 1/4 UNC FLANGE BOLT (GR 8) O&P
10	141A-2012	20	5/8 X 1 1/2 UNC FLANGE BOLT (GR 8) O&P
11	141A-2016	4	5/8 X 2 UNC FLANGE BOLT (GR 8) O&P
12	141A-2024	6	5/8 X 3 UNC FLANGE BOLT (GR 8) O&P
13	1455-0404	2	#4 X 1/4 DRIVE SCREW
14	1470-1200	6	3/8 UNC HEX NUT (GR B)
15	1474-1600	2	1/2 UNC HEX JAM NUT
16	1475-2400	2	3/4 UNF HEX JAM NUT
17	1476-2207	5	HEX TOP LOCK NUT, M22 X 2.5, CLASS 10
18	14771801	4	9/16 UNF HEX TOP LOCK NUT (GR C)
19	1480-1604	16	1/2 UNC TOP LOCK FL NUT (GR G) O&P
20	1480-2004	30	5/8 UNC TOP LOCK FL NUT (GR G) O&P
21	14871800	8	9/16 TYPE A PLAIN WASHER
22	14892200	10	WASHER-HARDENED, 22MM
23	1500-0843	2	BUSHING-SWAY BAR, POLYURETHANE
24	1500-1305	1	TAG-SERIAL, CABMATE
25	80001819	6	SHIM-LATERAL CONTROL ROD
26	80001954	2	CLAMP-MOUNT, SWAY BAR
27	80001955	1	PLATE-ADAPTER, AIR SPRING
28	80001957	1	PLATE-ADAPTER, AIR SPRING
29	80001959	1	SHIELD- HEAT
30	80001960	1	BRACKET-MOUNT, CROSSMEMBER
31	80001961	1	BRACKET-MOUNT, LATERAL CONTROL
32	80001962	1	BRACKET-MOUNT, LATERAL CONTROL
33	80001963	4	SHIM-SWAY BAR
34	80001964	1	SWAY BAR ASSEMBLY
35	800M1057	1	LATERAL CONTROL ROD
36	800M1058	1	BRACKET-MOUNT, CROSSMEMBER
37	800M1060	1	KIT-VALVE, BARKSDALE, FORD
38	810M0113	1	BRACKET-MOUNT, FRAME
39	810M0114	1	BRACKET-MOUNT, FRAME
40	820M0038	1	CONTROL ARM
41	820M0039	1	CONTROL ARM
42	830M0001	1	BRACKET-MOUNT, UPPER AXLE
43	830M0002	1	BRACKET-MOUNT, UPPER AXLE
44	830M0003	2	BRACKET-MOUNT, LOWER AXLE

TRUCKAT

AIR RIDE PARTS LIST - COMPRESSOR ASSY

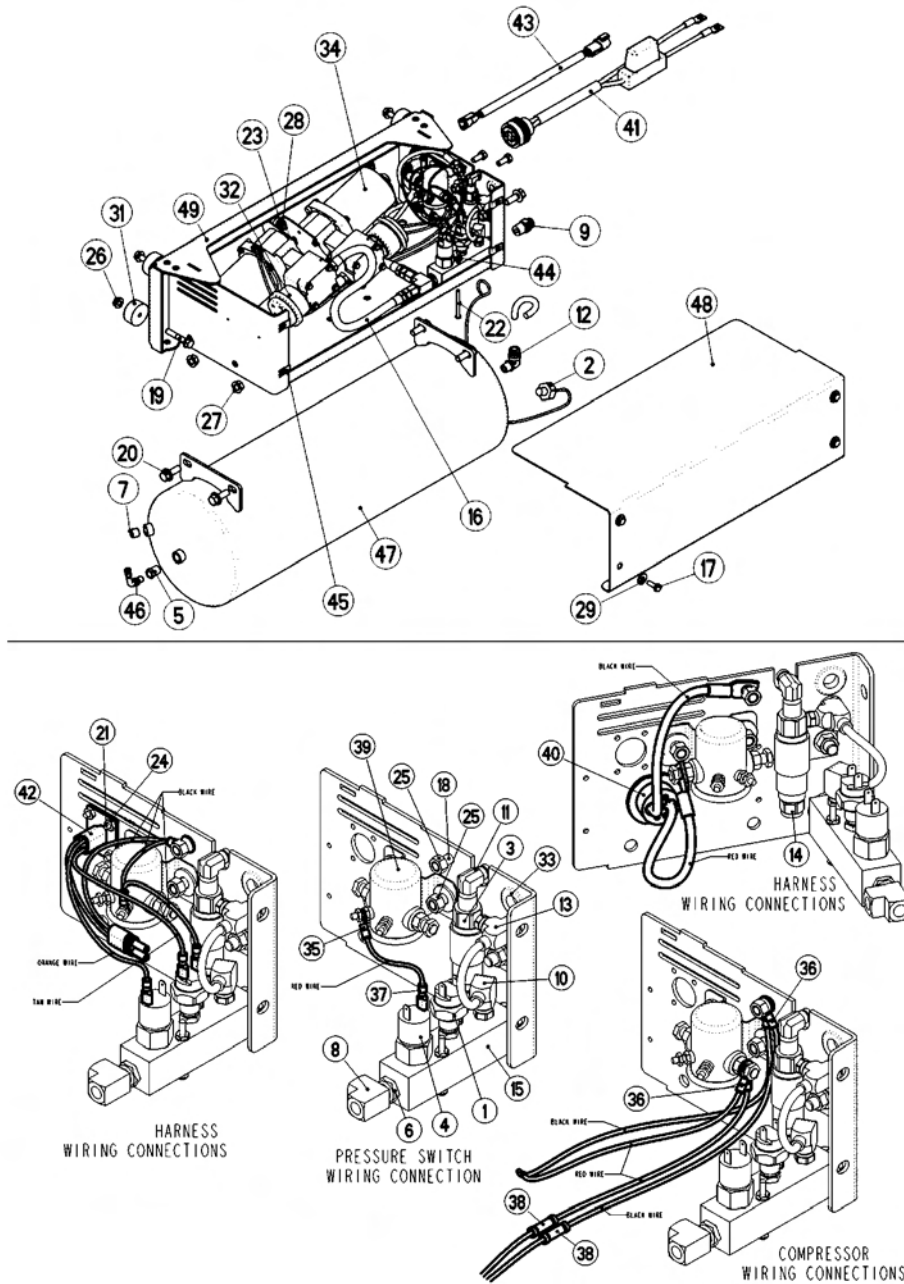

ITEM	PART NO.	QTY.	DESCRIPTION
1	06520296	1	SWITCH PRESSURE, LOW
2	13010537	1	VALVE-DRAIN, 20" CABLE
3	06520297	1	VALVE-SOLENOID,3-WAY
4	06510044	1	SWITCH-PRESSURE, 120/145
5	13022014	2	REDUCER, 1/8 F-NPT 1/4 M-NPT
6	13022016	1	BUSHING-REDUCER 3/8 M-NPT TO 1/4 F-NPT
7	13022077	1	AIR FTG / PLUG (1/4 NPT)
8	13022123	1	STREET TEE, 1/4 F-NPT 1/4 M-NPT

AIR RIDE PARTS LIST - COMPRESSOR ASSY

Continued...

ITEM	PART NO.	QTY.	DESCRIPTION
9	13025050	1	CONNECTOR-MALE, 3/8 TB, 3/8 NPT
10	13025091	1	ELBOW, 1/4 TB 1/4 M-NPT, PUSH-IN DOT
11	13025100	1	ELBOW, 1/4 TB 1/8 M-NPT, PUSH-IN DOT
12	13025104	1	ELBOW-3/8 TB, 1/4 M-NPT
13	13025140	1	BRANCH TEE, 1/4 TB 1/8 M-NPT, DOT, P-IN
14	13029973	1	EXHAUST SHIELD, 1/8 M-NPT
15	13029967	1	MANIFOLD-AIR, 3 PORT, 1/4 NPT
16	06520295	2	ASSEMBLY-HOSE, CHECK VALVE
17	14010806	4	1/4 X 3/4 UNC HEX CAP SCR (GR 5)
18	14011006	3	5/16 X 3/4 UNC HEX CAP SCR (GR 5)
19	141A1014	4	5/16 X 1 3/4 UNC FLANGE BOLT (GRADE 8) O&P
20	141A1208	5	3/8 X 1 UNC FLANGE BOLT (GRADE 8) O&P
21	14420C04	4	#8 X .500 CR PAN HEAD MACHINE SCREW
22	144N0B16	2	10-32 X 2 ROUND HEAD MACH. SCREW
23	14700600	6	10-24 UNC HEX NUT (GR B)
24	14700C00	4	8-32 UNC HEX NUT (GR B)
25	14701000	3	5/16 UNC HEX NUT (GR B)
26	14801004	4	5/16 UNC TOP LOCK FL NUT (GR G) O&P
27	14801204	5	3/8 UNC TOP LOCK FL NUT (GR G) O&P
28	14870600	6	3/16 TYPE A PLAIN WASHER
29	14870800	4	1/4 TYPE A PLAIN WASHER
30	14871000	2	5/16 TYPE A PLAIN WASHER
31	15000078	4	BUMPER-RUBBER
32	06520294	2	FILTER - AIR
33	15000312	1	GROMMET-RUBBER, 1/2
34	06520293	2	COMPRESSOR-AIR, THOMAS
35	15050055	1	TERMINAL-RING, #10 STUD, 14-16
36	15050627	4	TERMINAL-RING, 5/16 STUD, 12-10
37	15051100	1	CONNECTOR-SLIDE, FEMALE, 14-16
38	15051106	2	CONNECTOR-BUTT (16-14G)
39	06520285	1	RELAY-SAMS
40	15050037	1	HARNES-POWER, PANEL, AIR KIT
41	15050038	1	HARNES-POWER, AIR KIT
42	15050039	1	HARNES-CONTROL, PANEL, AIR KIT
43	15050041	1	HARNES-CONTROL, AIR KIT, ULTRARIDE
44	15060042	2	10-32 KEP NUT
45	15060411	4	U-NUT, 1/4-20
46	60002019	1	FITTING-INLET, AIR
47	80001495	1	TANK-AIR, WELDMENT
48	80001498	1	COVER-KIT, AIR, ULTRARIDE
49	800M1031	1	HOUSING-AIR KIT, ULTRARIDE, SPLIT

TRUCKAT

AIR SYSTEM COVER ASSEMBLY

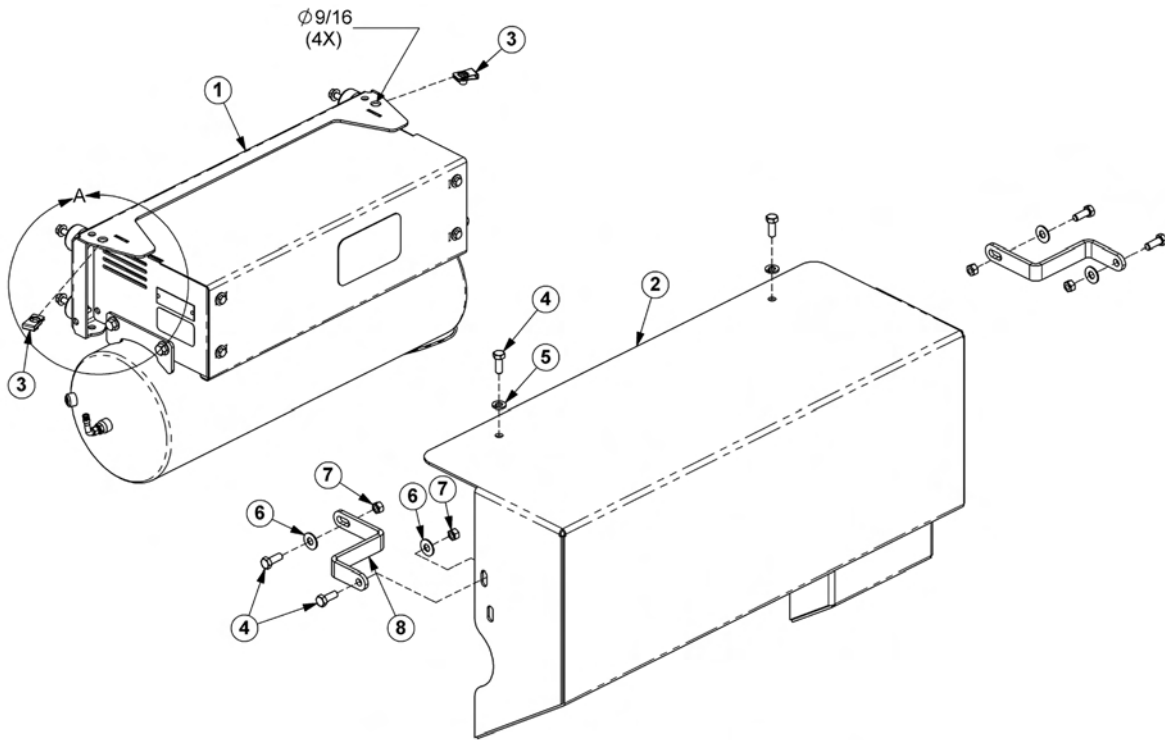

DRILL FOUR Ø9/16" HOLES INTO THE AIR SYSTEM MOUNTING BRACKET AS SHOWN

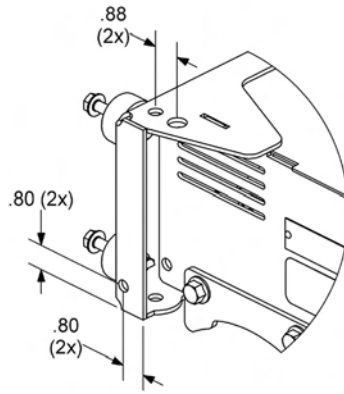

VIEW A

ITEM	PART NO.	QTY.	DESCRIPTION
1	800M1031	1	AIR SYSTEM
2	06370097	1	COVER
3	06537029	2	U-NUT,3/8"
4	21630	6	CAPSCREW,3/8" X 1,NC
5	21988	2	LOCKWASHER,3/8"
6	22016	4	FLATWASHER,3/8"
7	21627	4	NYLOCK NUT,3/8",NC
8	06410144	2	BRACKET

AIR RIDE DIAGRAM

TRUCKAT AIR RIDE DIAGRAM

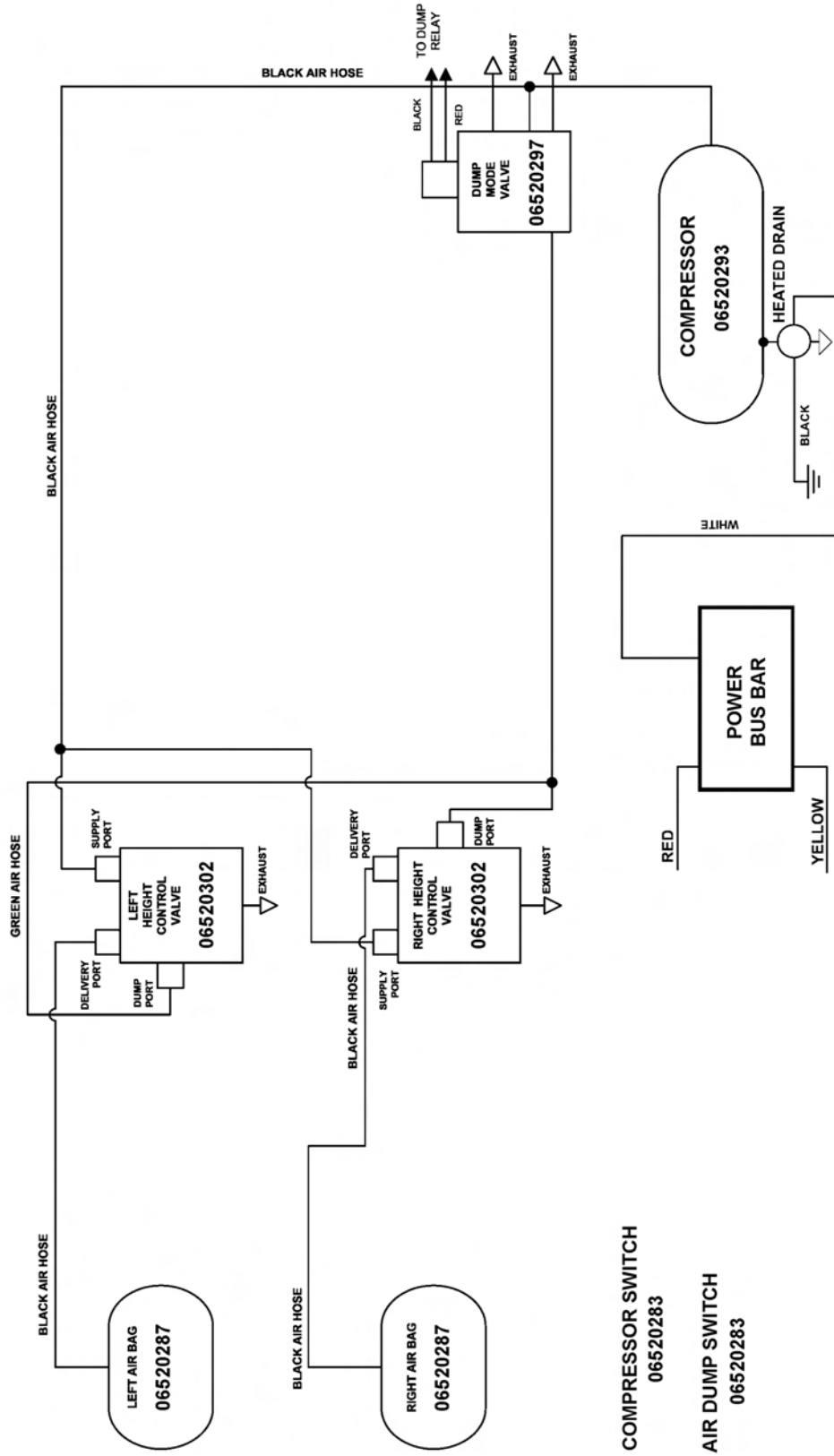

AIR RIDE SCHEMATIC

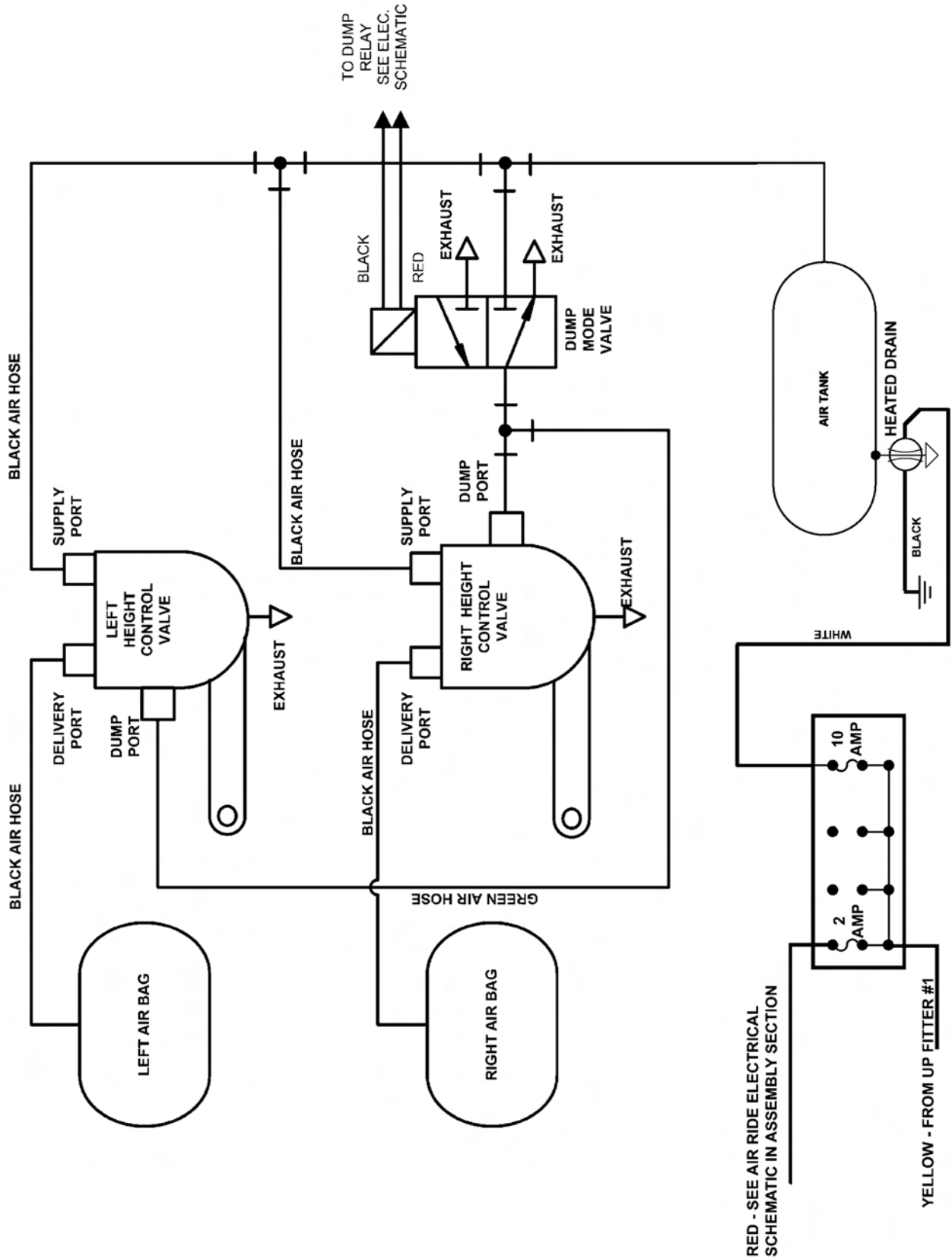

RED - SEE AIR RIDE ELECTRICAL SCHEMATIC IN ASSEMBLY SECTION

YELLOW - FROM UP FILTER #1

LIMIT STRAP INSTALLATION

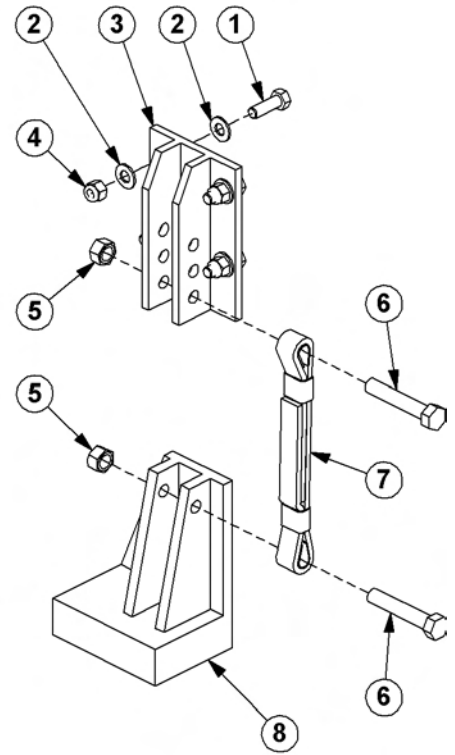
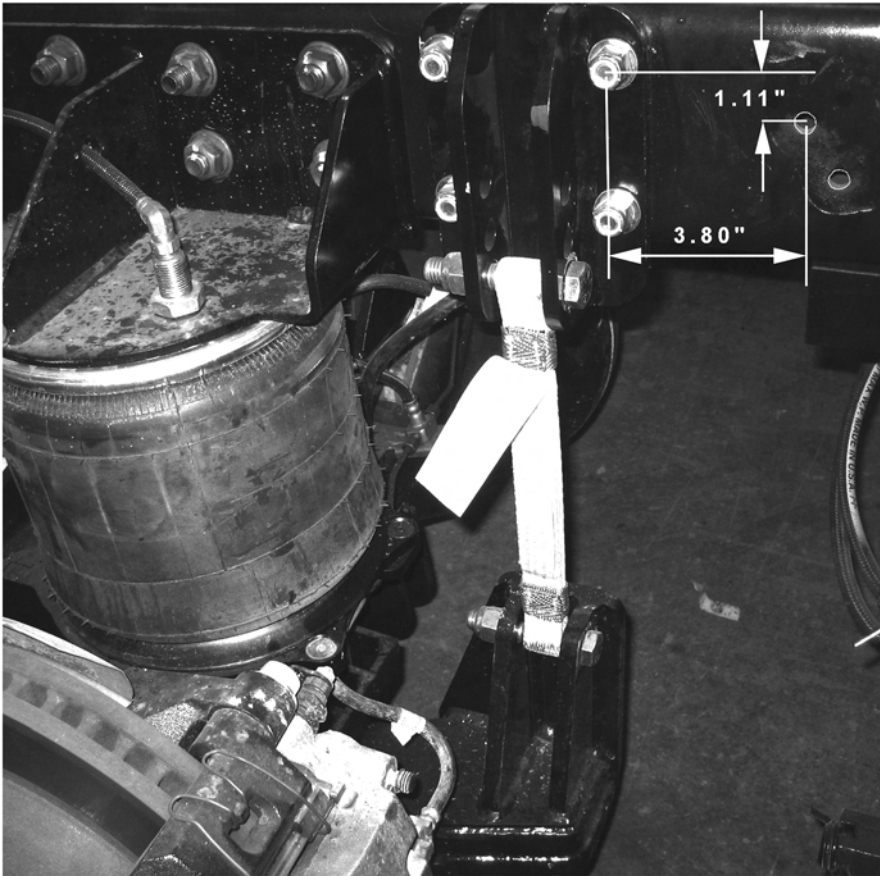

1. LOCATE AND MARK HOLE LOCATIONS (SEE ABOVE) FOR TOP BRACKET ON REAR LEFT TRUCK RAIL.
2. DRILL 1/2" HOLES IN MARKED LOCATIONS THROUGH TRUCK RAIL.
3. ASSEMBLE UPPER BRACKET (ITEM 3) TO TRUCK RAIL, AS SHOWN ABOVE, USING HARDWARE LISTED.
4. ASSEMBLE STRAP (ITEM 7) TO BRACKETS, AS SHOWN ABOVE, USING HARDWARE LISTED.

ITEM	PART NO.	QTY.	DESCRIPTION
1	6T2279	4	CAPSCREW, 1/2" X 1-1/2", NC
2	06533004	8	FLATWASHER, 1/2", SAE
3	06510129	1	BRACKET, UPPER, EXT LIMIT
4	21727	4	NYLOCK NUT, 1/2", NC
5	21777	2	NYLOCK NUT, 5/8"
6	21789	2	CAPSCREW, 5/8" X 3-1/2", NC
7	06510120	1	STRAP
8	-----	-	EXISTING BOTTOM BRKT

TRUCKAT

LIFT VALVE HYDRAULIC DIAGRAM

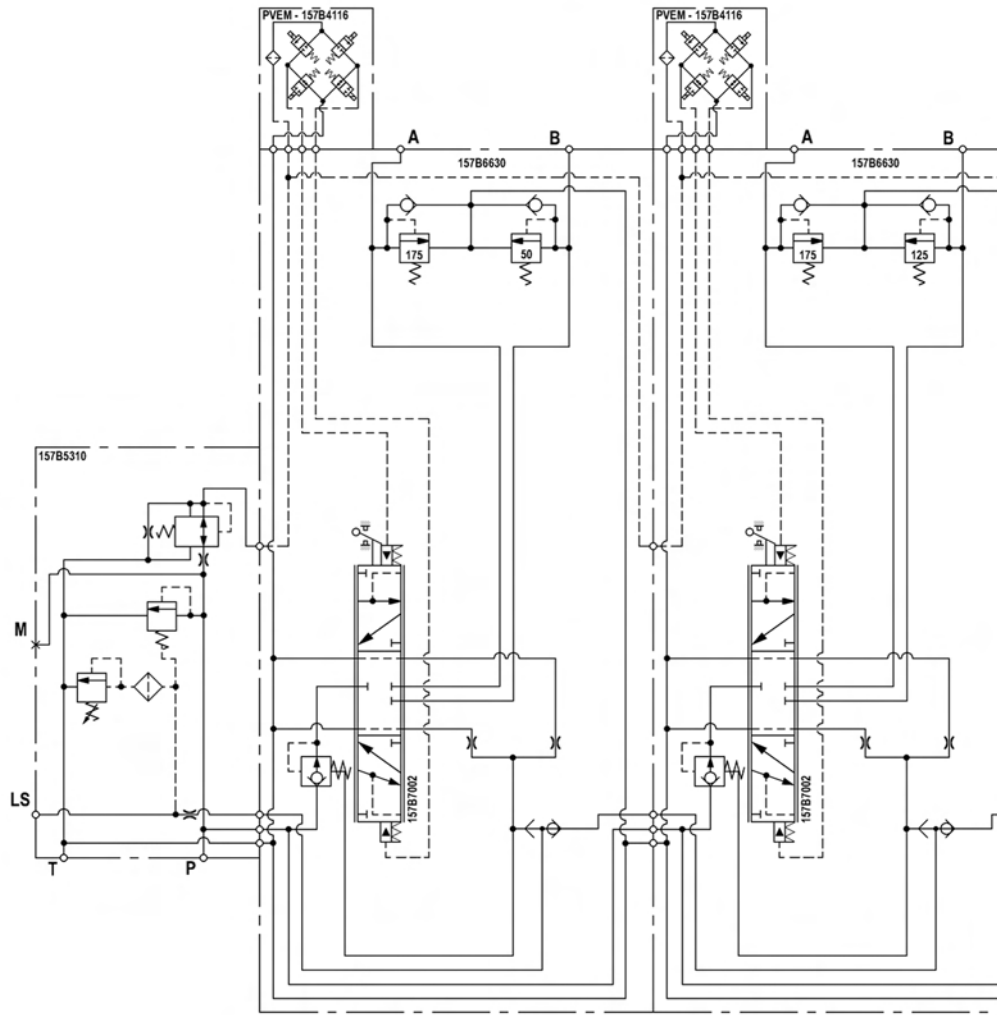

LIFT VALVE HYDRAULIC DIAGRAM - CONTINUED

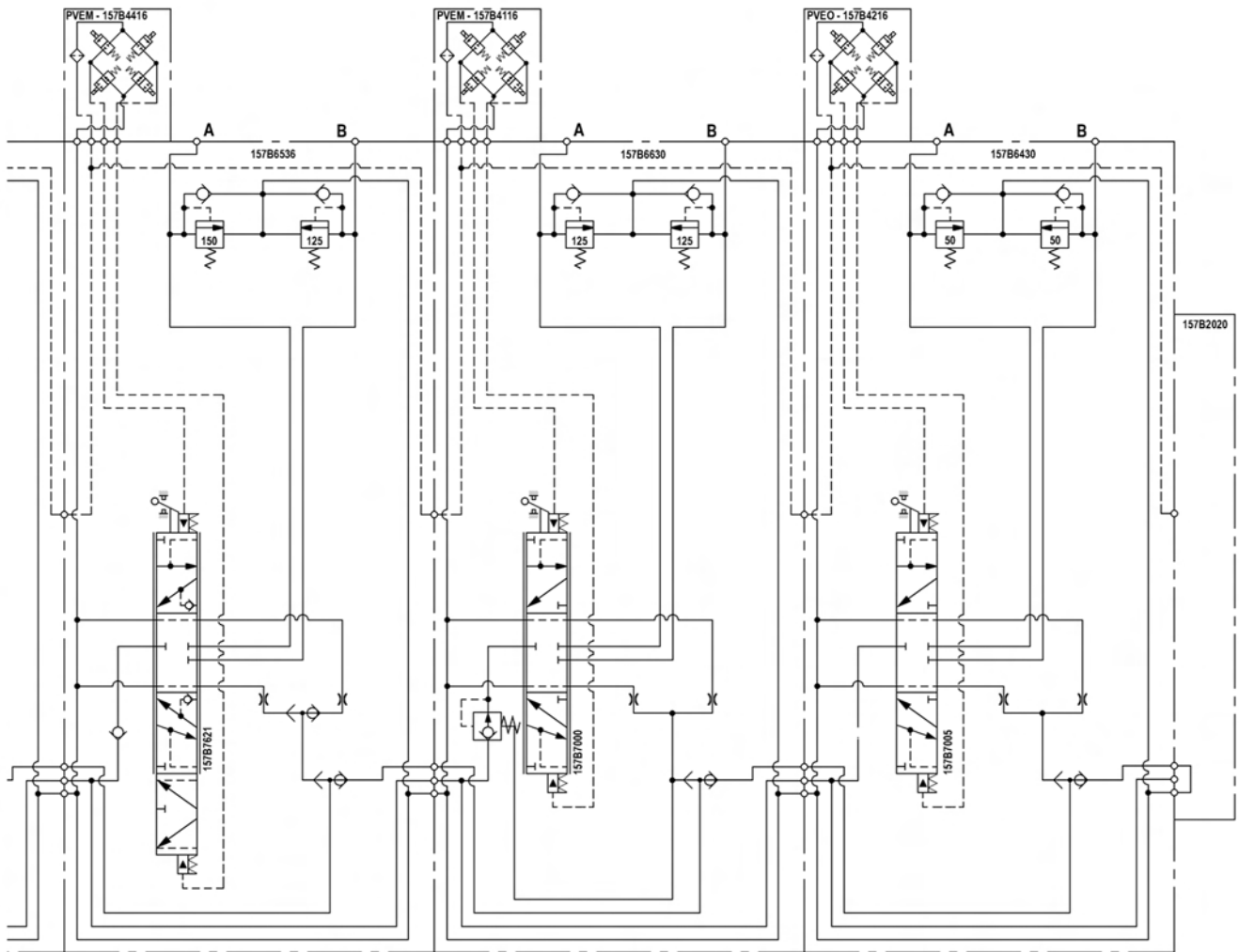

AUXILLARY ENGINE CONSOLE SCHEMATIC

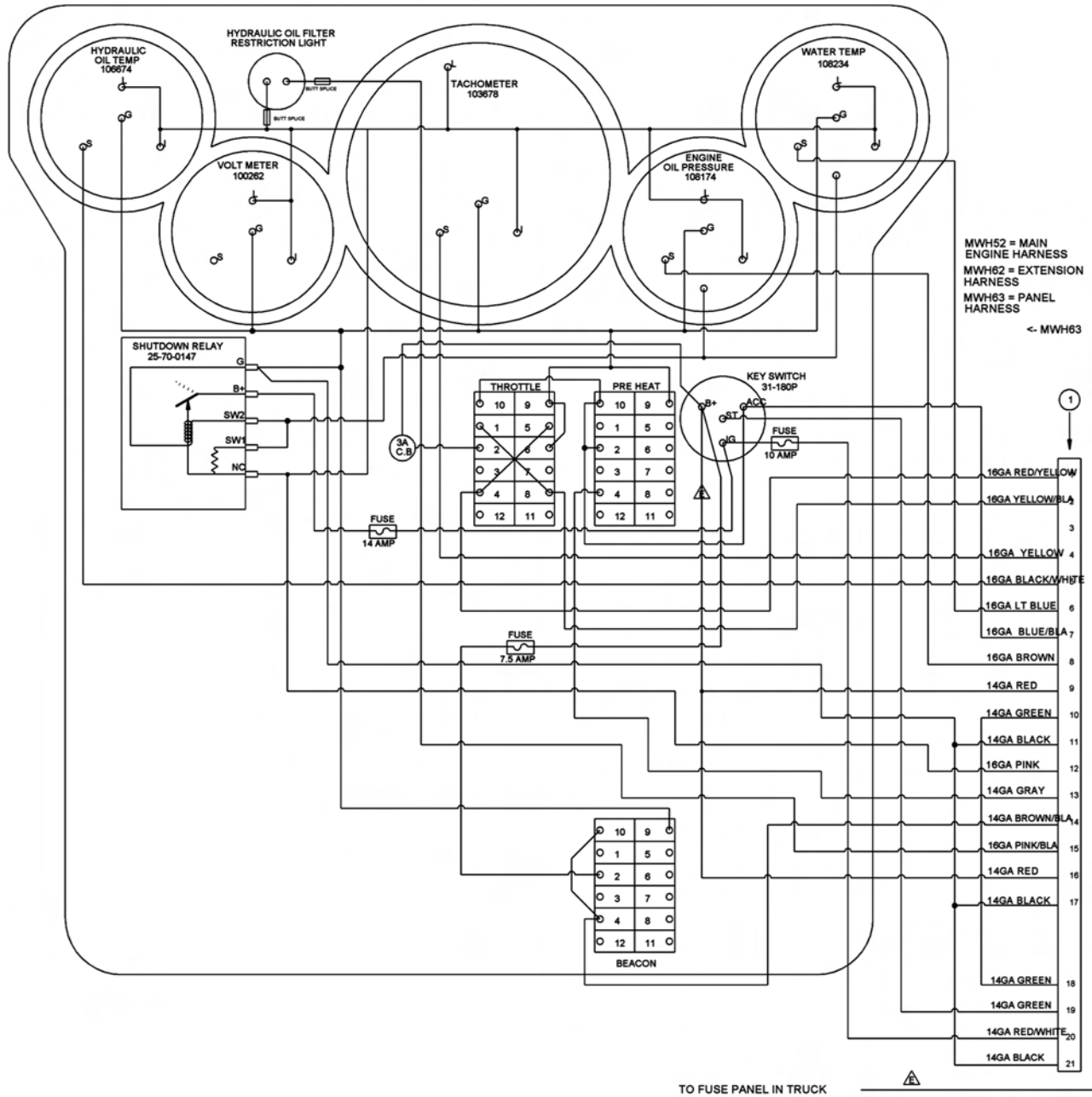

AUXILLARY ENGINE CONSOLE SCHEMATIC - CONTINUED

WIRING SCHEMATIC B3.3 POWER UNIT FOR TIGER

CONNECTOR SCHEDULE	
1	DEUTSCH HDP26-24ST
2	DEUTSCH HDP24-24-31PT
3	DEUTSCH DT04-2P
4	DEUTSCH DT06-2S
5	2-PIN WEATHERPACK SHROUD WITH MALE PINS
6	2-PIN WEATHERPACK TOWER WITH FEMALE SOCKETS

MWH52 = MAIN ENGINE HARNESS
MWH62 = EXTENSION HARNESS
MWH63 = PANEL HARNESS

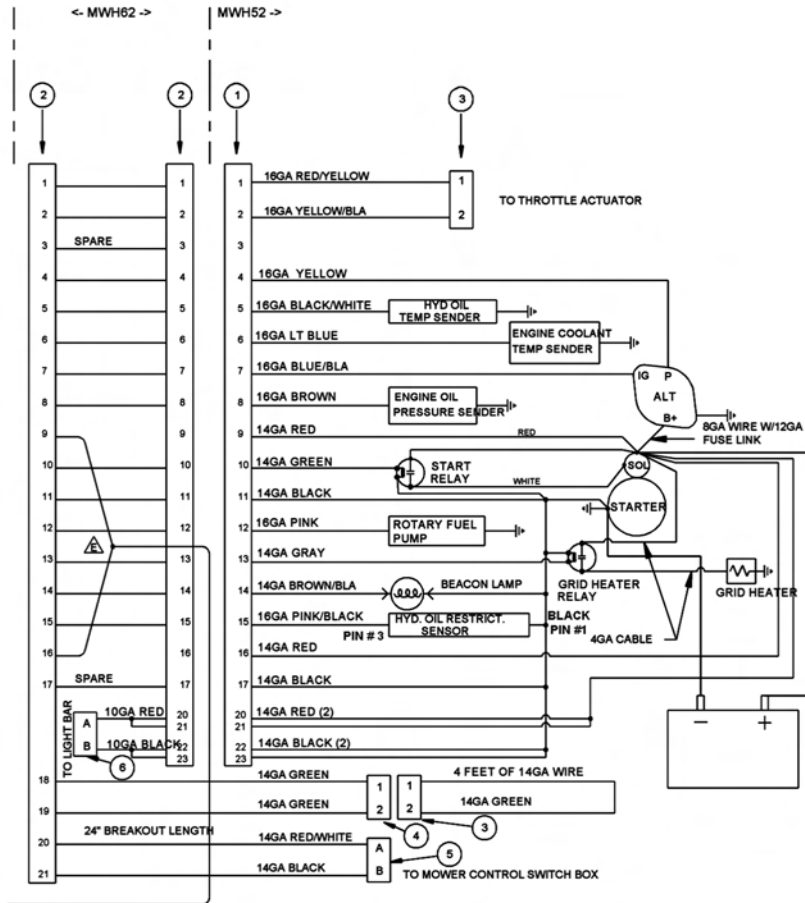

SWITCH BOX SCHEMATIC

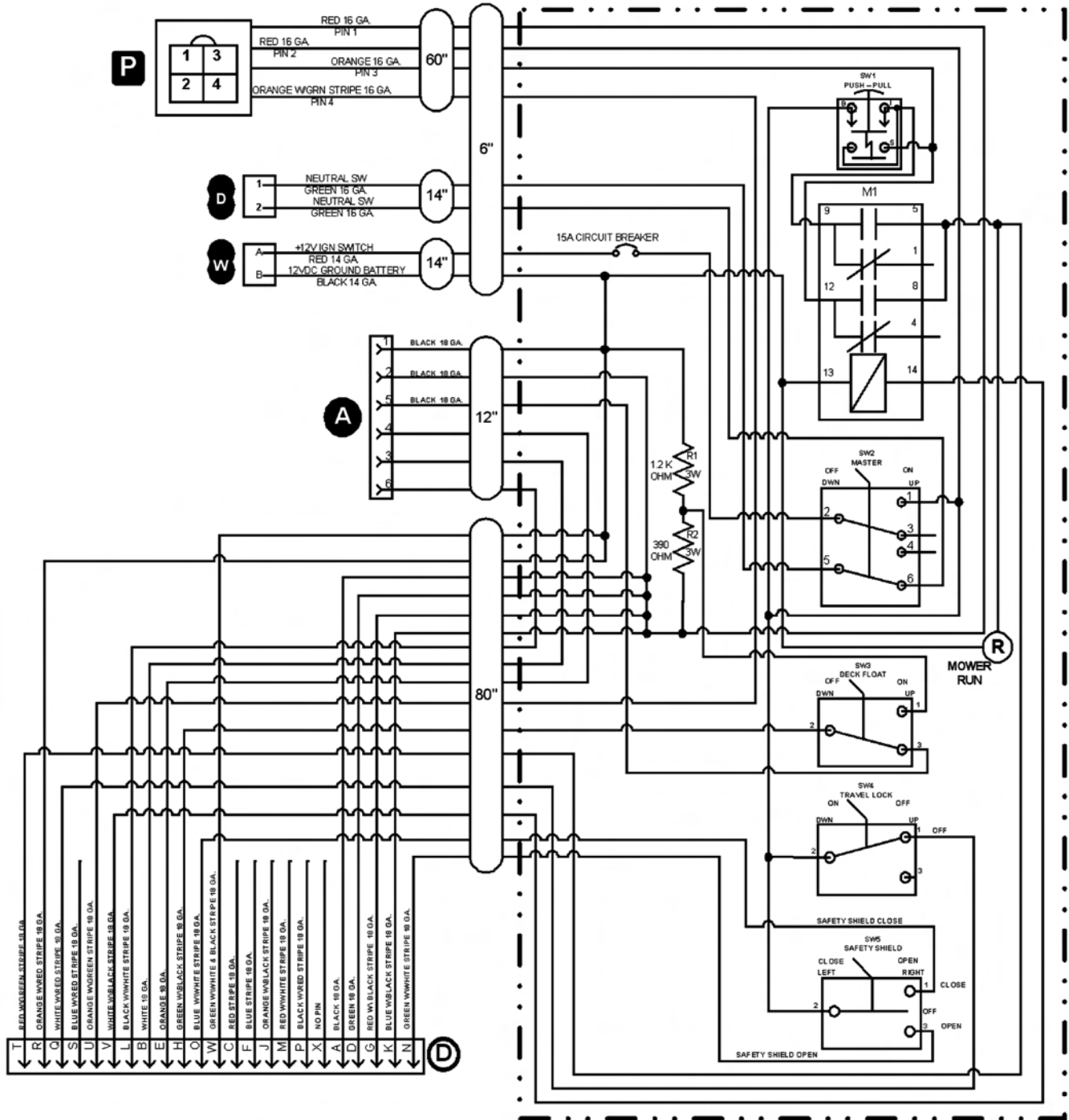

JOYSTICK AND SWITCH BOX DIAGRAM

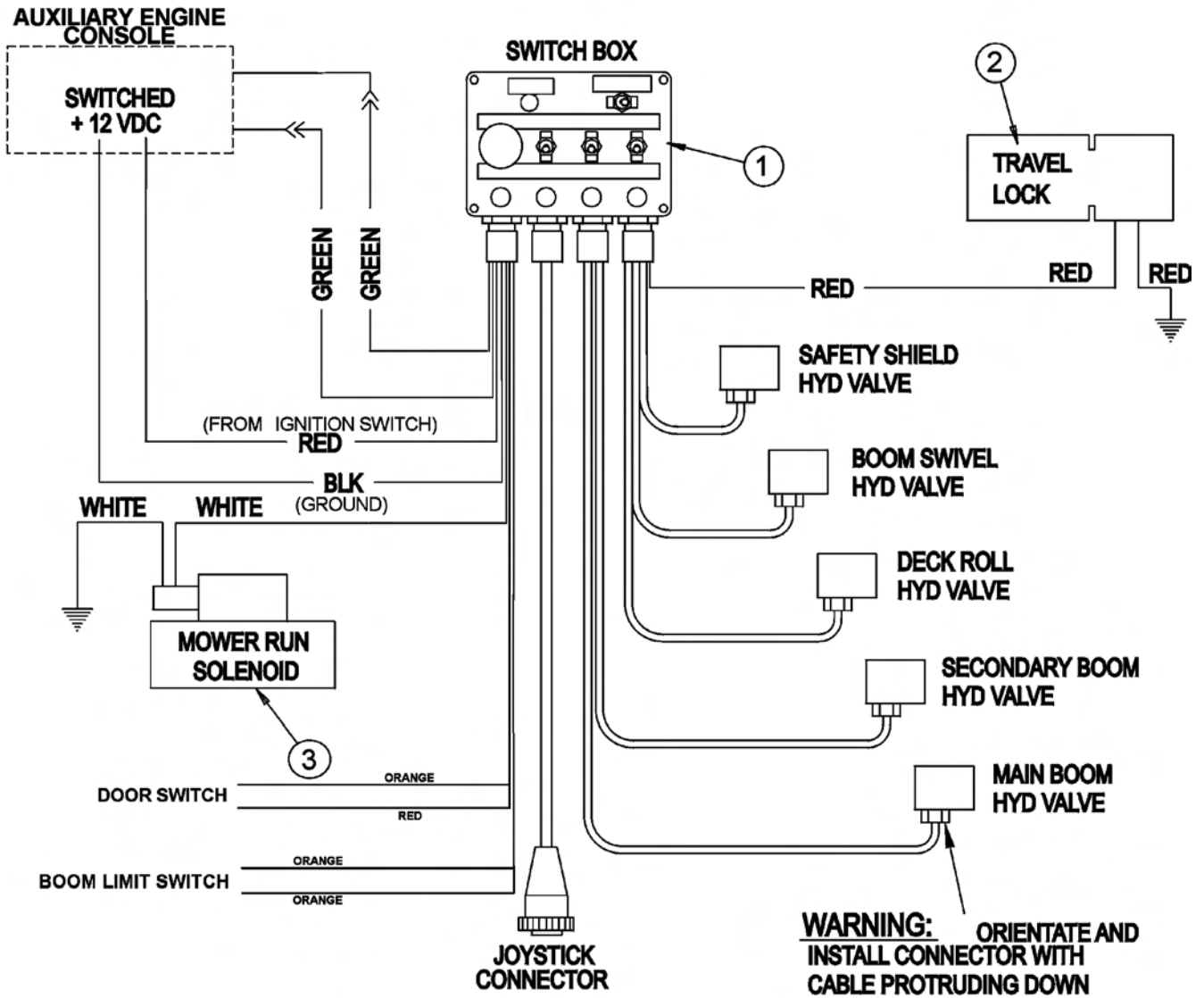

ITEM	PART NO.	QTY.	DESCRIPTION
1	-----	-	SWITCH BOX *REFER TO SWITCH BOX MOUNT PAGE
2	-----	-	TRAVEL LOCK *REFER TO COMMON BOOM PAGE
3	-----	-	BRAKE VALVE *REFER TO MOWER HYDRAULICS PAGE

SWITCH BOX BREAKDOWN

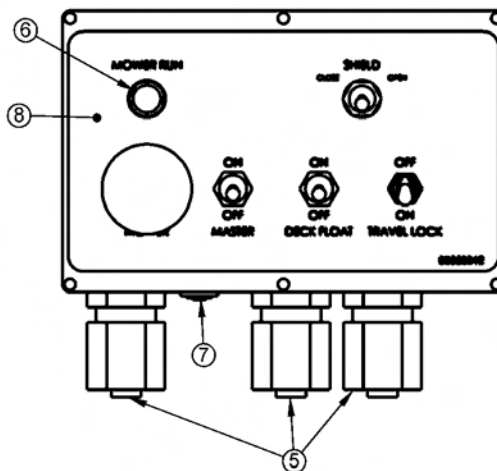
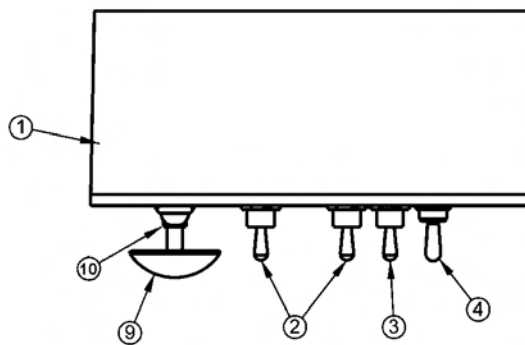

ITEM	PART NO.	QTY.	DESCRIPTION
1	06514009	1	SWBX,ALUM,BLK
2	33811	2	SWITCH,MASTER/DECK FLOAT
3	33813	1	SWITCH,SFTY SHIELD
4	34532	1	SWITCH,TRVL LCK
5	34540	3	STRAIN RELIEF,3/4",BLACK,NYLON
6	6T3923	1	INDICTATOR LIGHT,ON,RED
7	06514006	1	BREAKER,15A,SWBX
8	06550042	1	DECAL,SWBX
9	02964063	1	KNOB,RED
10	35226	1	SWITCH,MOWER,COLEHERSEE

NOTES

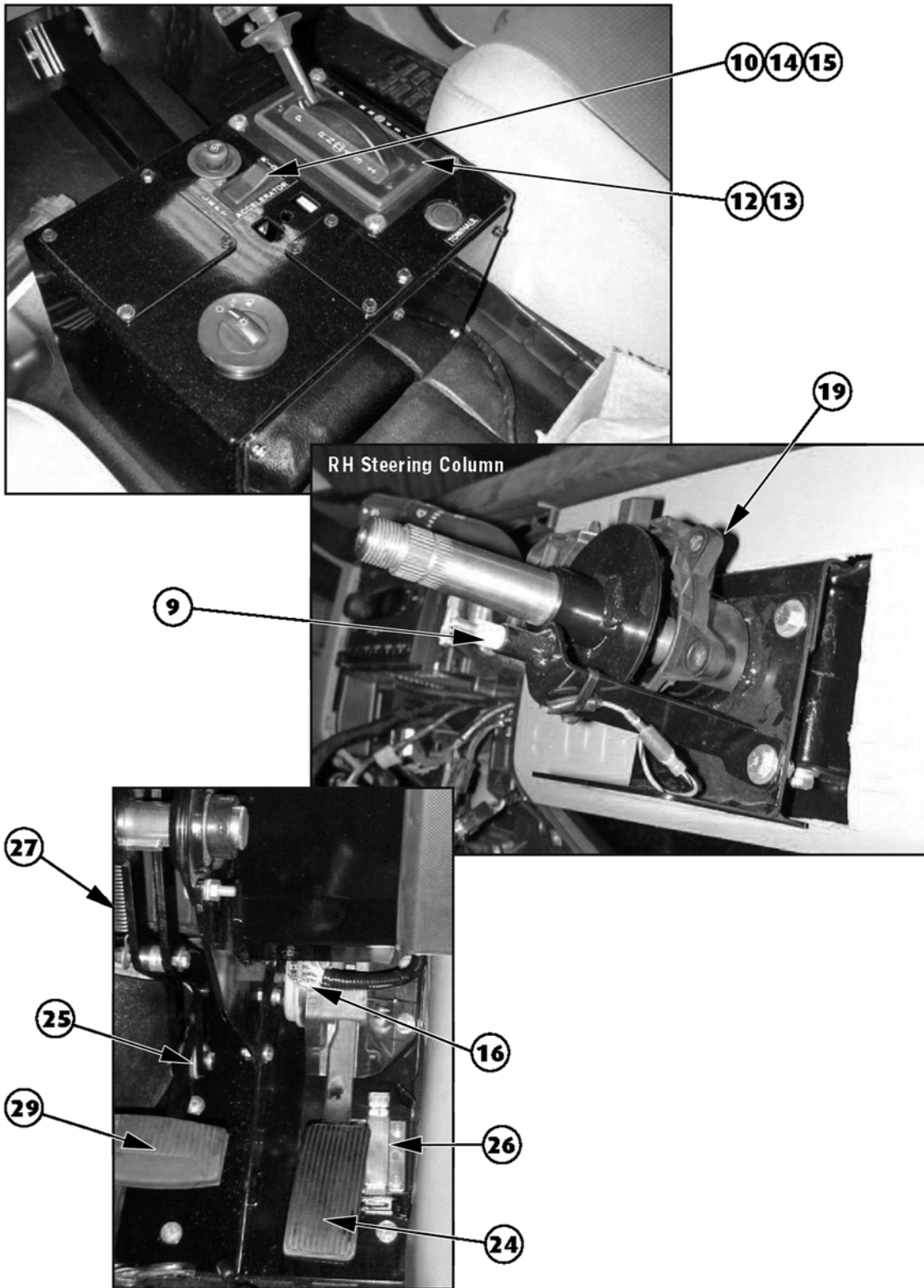

RH STEER MODIFICATIONS - PAGE 2

ITEM	QTY.	PART NUMBER	DESCRIPTION
1	1	00120925	Dual Steer Kit, Ford SD Dual Steer <i>(See pages 2-3 for parts)</i>
2	Varies	00010920	Bracket Weldment, Suspension Restraint, Upper <i>(See page 4)</i>
3	Varies	00010926	Bracket Weldment, Suspension Restraint, Lower <i>(See page 4)</i>
4	Varies	5449	Strap, Suspension Limiting
5	2	00011345	Shaft, Gearbox, Steering
6	1	00012284	Gearbox, 2-Shaft
7	2	085-UA104	U-Joint, 3/4" I.D. Smooth x 13/16-36 Spline
8	4	1YHM	Bolt, 1/2" x 8 1/2"
9	1	2033031	Horn Contact with Spring
10	1	511.106	Switch, Rocker, On/Off with Light
11	8	52MST	Flange, 2-Bolt
12	1	55835-1	Shifter, T-Handle
13	1	59002	Flange, Shifter Mount to Tower
14	1	596.289	Connector, Switch
15	1	596.650	Lens for Switch, Green
16	1	6U2Z-14S411-MA	Pigtail, Electric Throttle
17	2	7493	End Yoke, 1" Rd x 1/4" KW
18	13	75280	Fuse, Relay Connector
19	1	7C3Z-13K359AA	Turn Signal Switch
20	1	7C3Z-3530AD	Steering Column Cover
21	1	7C3Z-3F791A	Turn Signal Mount
22	1	7C3Z3E751B	Steering Column Shaft
23	1	8C3Z-14401EA	Wire Harness, Dash
24	1	8C3Z-9F836D	Accelerator Pedal, ASM, Elec
25	8	90295A188	Washer, Nylon, 1/2" I.D. x 1 1/4" O.D.
26	1	90M	Bolt Latch, Finger Pull
27	1	9290K47	Spring, Extension
28	1	BBBL16552SS	Steering Wheel
29	1	D3TZ2457B	Pad, Brake Pedal
30	1	FF550SDE	Timbren Load Booster Kit, Front
31	1	HB9T	Horn Button, with Trumpet
32	13	HE-87429B	Relay
33	1	MTEB0YER	Label Set, F550 Dual Steer Tiger
34	1	NB7A	U-Joint
35	1	R100-QT4160	Gearbox, 3-Shaft, Universal
36	4	RA100RRB	Bearing, 1" with Collar
37	1	275	Transmission Temp Gauge

RH STEER MODIFICATIONS - PAGE 3

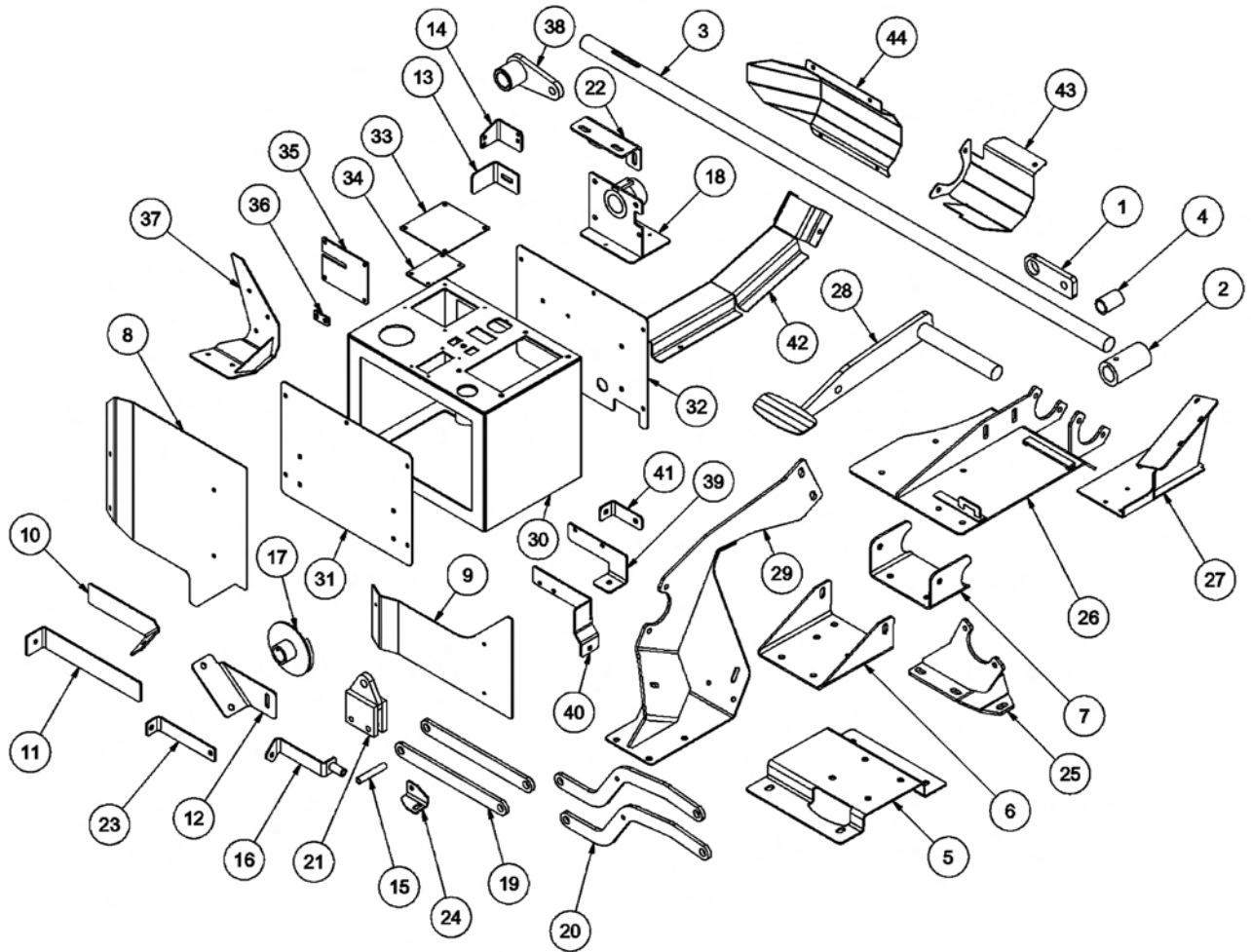

RH STEER MODIFICATIONS - PAGE 4

00120925 DUAL STEER KIT, FORD SD DUAL STEER			
Item	Qty	Part Number	Description
1	1	00096571	Bracket, Brake Pedal Leg, Top, LH
2	1	00097051	Coupling Shaft, Upper
3	1	00098835	Shaft, Brake Pedal
4	1	00120218	Adapter, Coupler, Upper
5	1	00120927	Bracket, Mounting, Gearbox, LH,
6	1	00120928	Bracket, Mounting, Steering Column, RH
7	1	00120929	Brace, Mounting, Steering Column, RH
8	1	00121161	Cover Plate, Inner, Steering Column, RH
9	1	00121162	Cover Plate, Outer, Steering Column, RH
10	1	00121163	Bracket, Mounting, Cover Plate, Outer
11	1	00121164	Bracket, Mounting, Cover Plate, Inner
12	1	00121165	Bracket, Cover Plate
13	1	00121166	Mounting Tab, Cover Plate, Inner
14	1	00121167	Bracket, Mounting, Wire Harness
15	1	00121168	Pipe, MS, 1/2" SCH40 x 2 1/2"
16	1	00121169	Bracket Weldment, Mounting, Horn
17	1	00121171	Bracket Weldment, Cancel, Direction
18	1	00121174	Bracket Weldment, Mounting, Turn Signal
19	2	00121179	Bar, Linkage, Brake, LH
20	2	00121180	Bar, Linkage, Brake, RH
21	1	00121181	Adapter Weldment, Pedal, Brake
22	1	00121184	Bracket, Support, Turn Signal
23	1	00121185	Bracket, Mounting, Dash Support
24	1	00121186	Bracket, Mounting, Dash
25	1	00121187	Support Weldment, Steering Column, LH
26	1	00124454	Bracket Weldment, Mounting, Brake Pedal
27	1	00121197	Bracket Weldment, Mounting, Accel Pedal
28	1	00121801	Brake Pedal Weldment
29	1	00121804	Steering Column Weldment, RH
30	1	00121807	Control Box Weldment
31	1	00121809	Panel, Side, Control Box, Rear
32	1	00121810	Panel, Side, Control Box, Front
33	1	00121811	Cover Plate, Control Box
34	1	00121812	Cover Plate, Switch, Control Box
35	1	00121813	Retainer Plate, Carpet
36	1	00121814	Mounting Plate, Shifter Cable
37	1	00121815	Bracket Weldment, Dash Support
38	1	00121818	Brake Arm Weldment, RH
39	1	00121872	Bracket, Mounting, Relay, RH
40	1	00121873	Bracket, Mounting, Relay, LH
41	1	00121874	Support Bracket, Shift Cable
42	1	00121875	Cover, Wire Harness
43	1	00121879	Cover Weldment, Shaft, RH
44	1	00121882	Cover, Shaft, LH

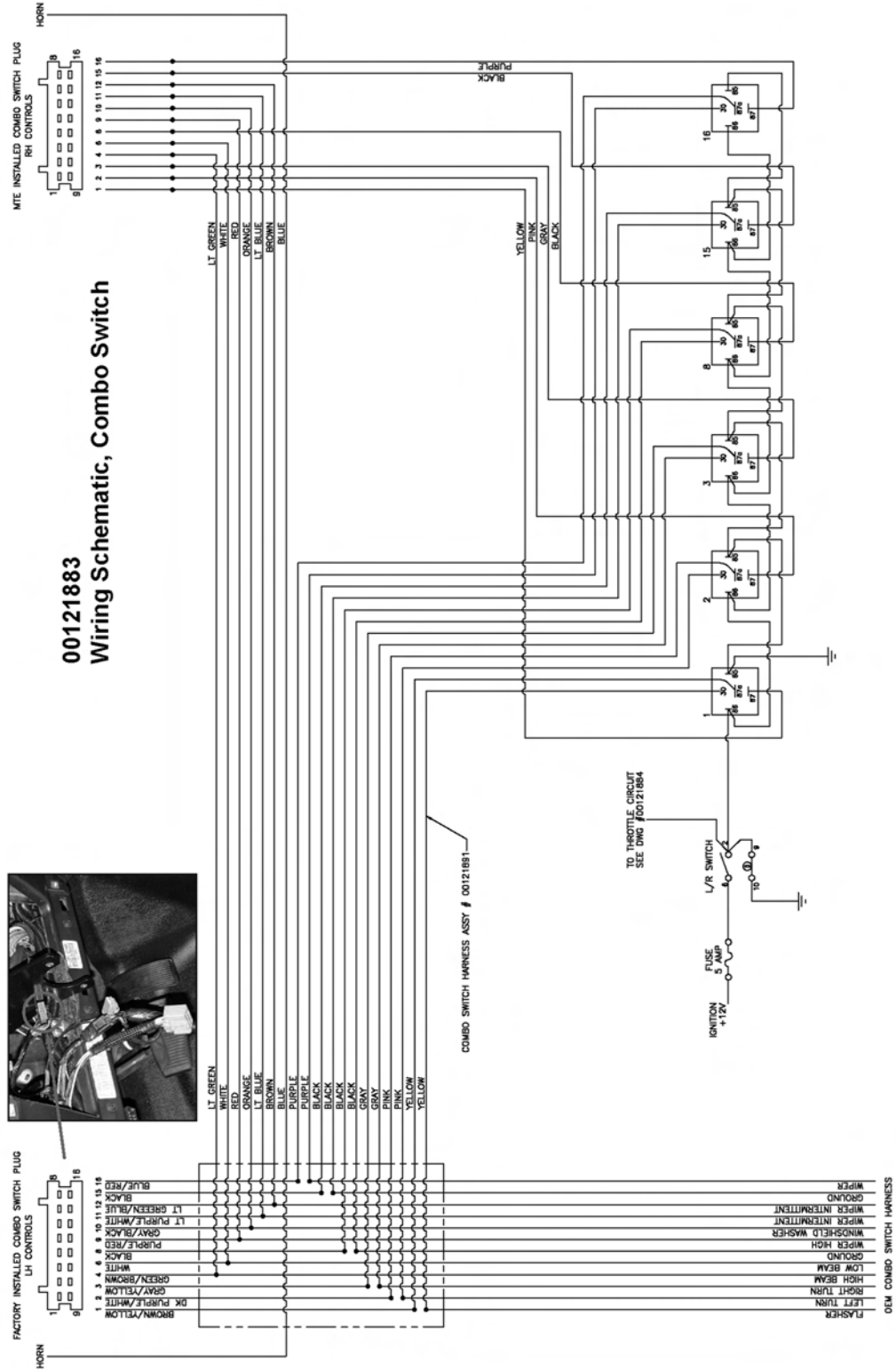

00121891
 Harness Assembly, Combo Switch

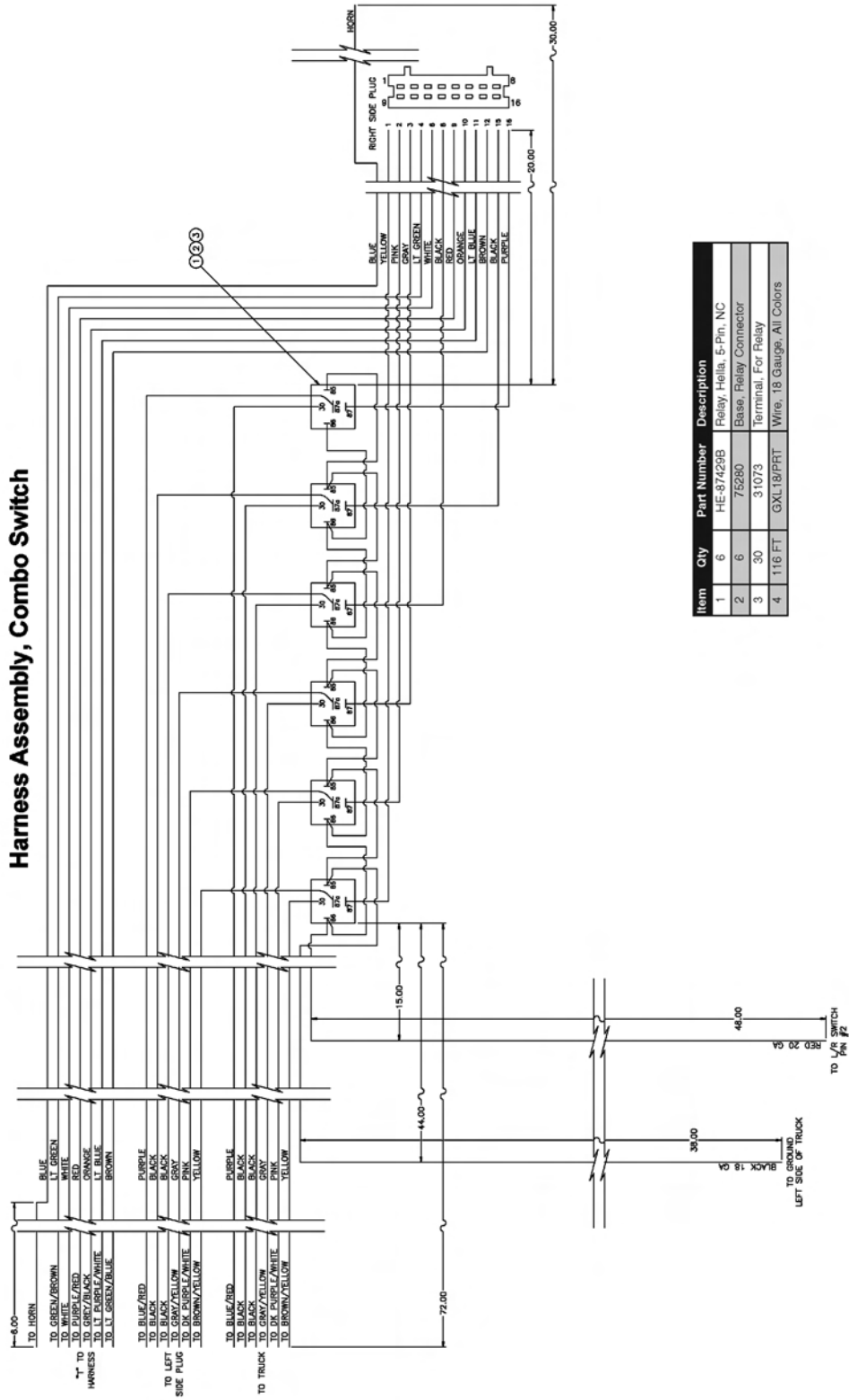

Item	Qty	Part Number	Description
1	6	HE-87429B	Relay, Hella, 5-Pin, NC
2	6	75280	Base, Relay Connector
3	30	31073	Terminal, For Relay
4	116 FT	GXL18/PRT	Wire, 18 Gauge, All Colors

NOTE: INSTALLED THROTTLE PEDAL PLUG RIGHT

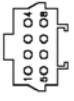

00121884

Wiring Schematic, Throttle

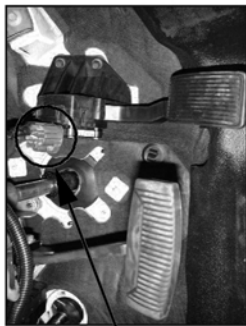

FACTORY INSTALLED THROTTLE PEDAL PLUG LEFT

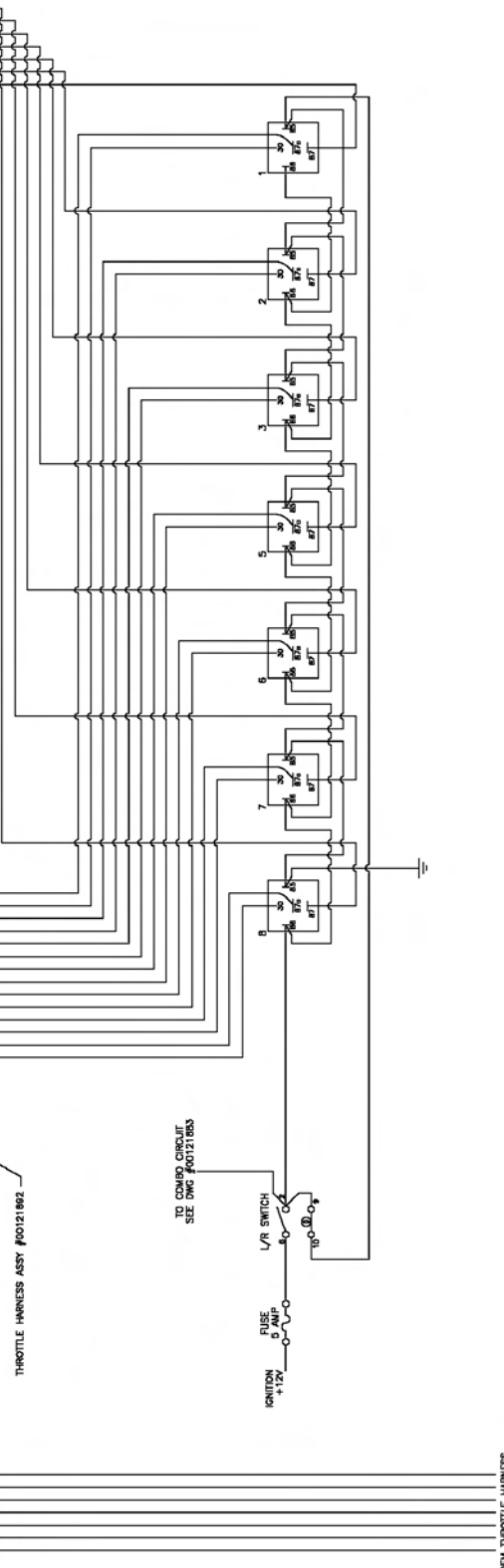
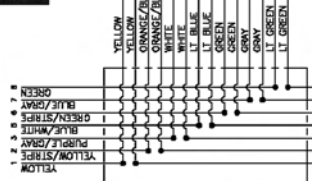
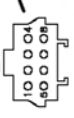

00121892
Harness Assembly, Throttle

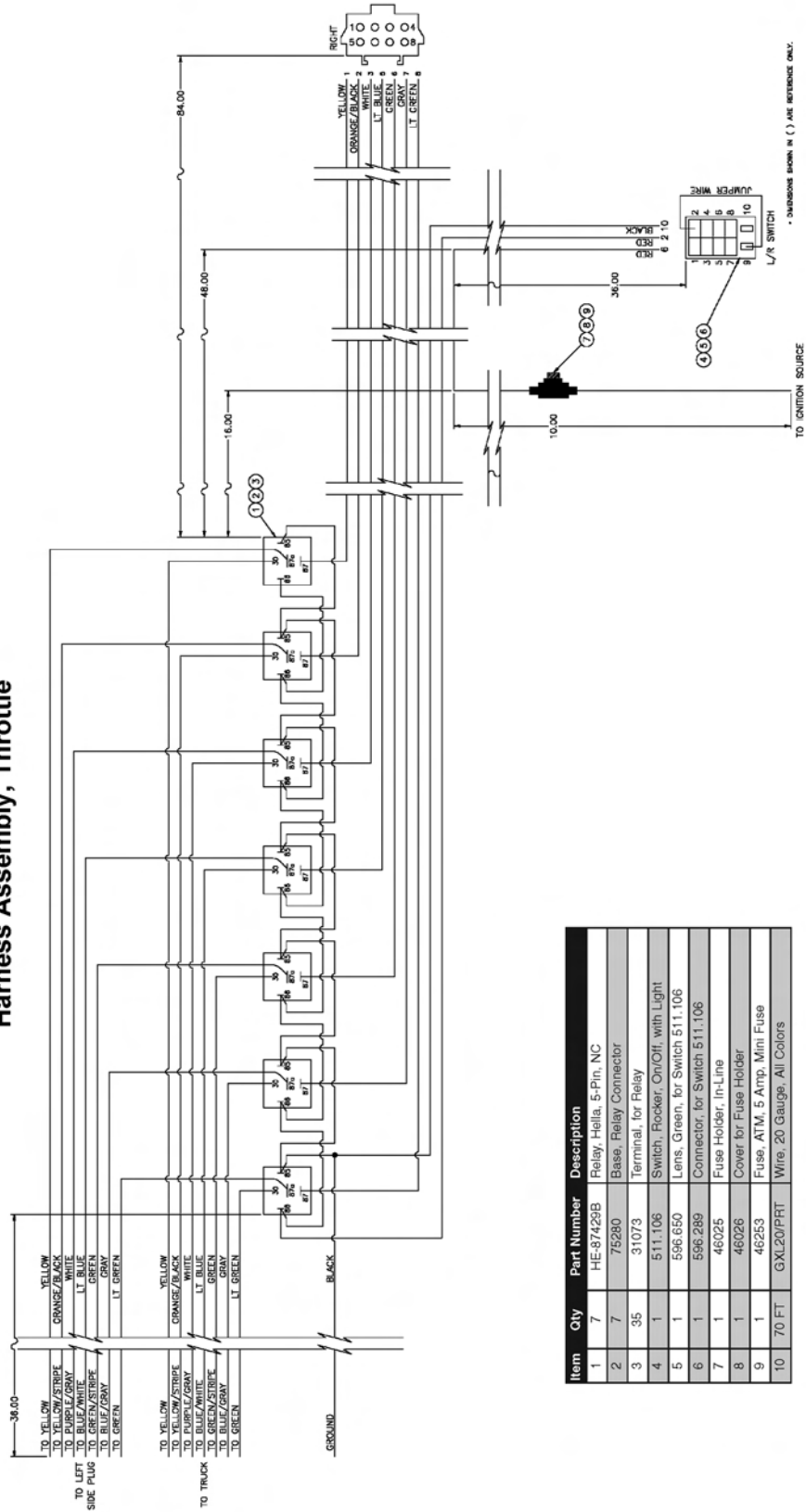

Item	Qty	Part Number	Description
1	7	HE-87429B	Relay, Hella, 5-Pin, NC
2	7	75280	Base, Relay Connector
3	35	31073	Terminal, for Relay
4	1	511.106	Switch, Flocker, On/Off, with Light
5	1	596.650	Lens, Green, for Switch 511.106
6	1	596.289	Connector, for Switch 511.106
7	1	46025	Fuse Holder, In-Line
8	1	46026	Cover for Fuse Holder
9	1	46253	Fuse, ATM, 5 Amp, Mini Fuse
10	70 FT	GXL20/PRT	Wire, 20 Gauge, All Colors

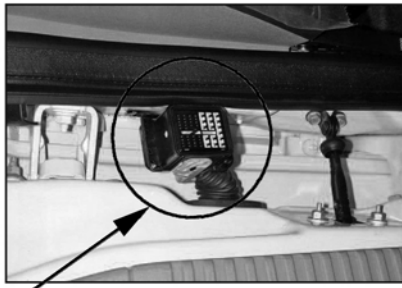

OEM Plug, LH Door Jam

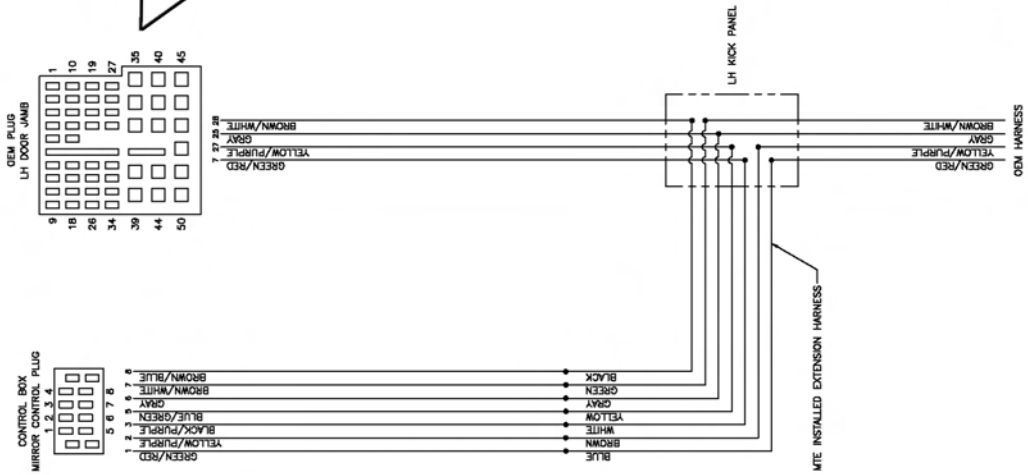

00121890
Wiring Schematic, Mirror Control

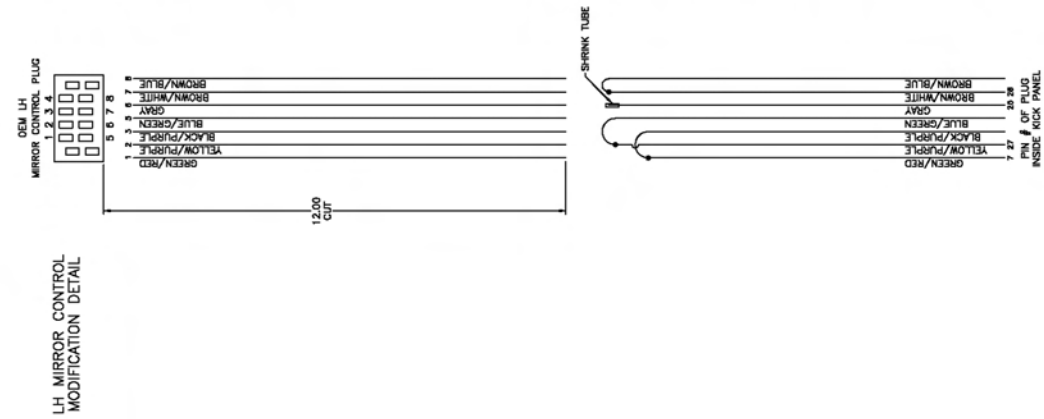

COMMON TRUCKAT/RAILKUT

PARTS SECTION

NOTES



PART NAME INDEX

PARTS ORDERING GUIDE.....	5
BOOM ASSY - BENGAL 22.....	6
BOOM HYD ASSY - BENGAL 22.....	8
BOOM ROTARY PIVOT ASSEMBLY.....	10
BOOM FLAIL PIVOT ASSEMBLY.....	12
50IN ROTARY MOWER ASSEMBLY.....	14
60IN ROTARY MOWER ASSEMBLY.....	16
50IN ROTARY KNIVES AND DISH.....	18
60IN ROTARY BLADE BAR AND KNIVES.....	19
60IN ROTARY KNIVES AND DISH.....	20
NOTES.....	21
ROTARY MOWER SPINDLE ASSEMBLY.....	22
50IN FLAIL DRIVE ASSEMBLY.....	24
50IN FLAIL MOWER ASSEMBLY.....	26
63IN FLAIL DRIVE ASSEMBLY.....	28
63IN FLAIL MOWER ASSEMBLY.....	30
3IN X 17-1/2IN WELDED CYLINDER BREAKDOWN.....	32
3IN X 18IN WELDED CYLINDER BREAKDOWN.....	33
3-1/2IN X 20IN WELDED CYLINDER BREAKDOWN.....	34
4IN X 20IN WELDED CYLINDER BREAKDOWN.....	35
50IN AND 63IN FLAIL MOTOR BREAKDOWN.....	36
50IN AND 60IN ROTARY MOTOR BREAKDOWN.....	38
RESERVOIR TANK FILTER ASSEMBLY.....	40
BRAKE VALVE ASSEMBLY.....	41
BRAKE VALVE HYDRAULIC SCHEMATIC.....	42
CLEAN CUTTER HEAD.....	43
CLEAN CUTTER ASSEMBLY.....	44
CLEAN CUTTER OPERATION.....	45
CLEAN CUTTER OPERATION - CONTINUED.....	46
CLEAN CUTTER MAINTENANCE.....	47
CLEAN CUTTER BLADE AND TEETH PARTS.....	48
CARBIDE TIP REPLACEMENT.....	49
NOTES 1.....	50
FIRE SUPPRESSION SYSTEM.....	51
FIRE SUPPRESSION SYSTEM PARTS.....	52
FIRE SUPPRESSION SYSTEM ELECTRICAL SCHEMATIC.....	54
WETCUT.....	55
WETCUT 50 GALLON TANK MOUNT.....	56
WETCUT 100 OR 150 GALLON TANK MOUNT.....	57
WETCUT TANK PLUMBING.....	58

COMMON TRUCKAT/RAILKUT

PART NAME INDEX

WETCUT 50IN SPRAYER HEAD ASSEMBLY.....	60
WETCUT 60IN SPRAYER HEAD ASSEMBLY.....	62
WETCUT CABLES.....	64

PARTS ORDERING GUIDE

The following instructions are offered to help eliminate needless delay and error in processing purchase orders for the equipment in this manual.

1. The Parts Section is prepared in logical sequence and grouping of parts that belong to the basic machine featured in this manual. Part Numbers and Descriptions are given to help locate the parts and quantities required.
2. The Purchase Order must indicate the **Name and Address** of the person or organization ordering the parts, **who should be charged**, and if possible, the **serial number of the machine** for which the parts are being ordered.
3. The purchase order must clearly list the **quantity of each part**, the complete and correct **part number**, and the basic **name of the part**.
4. The manufacturer reserves the right to substitute parts where applicable.
5. Some parts may be unlisted items which are special production items not normally stocked and are subject to special handling. Request a quotation for such parts before sending a purchase order.
6. The manufacturer reserves the right to change prices without prior notice.

NOTE: When ordering replacement decals, refer to the part numbers and descriptions listed in the safety section in the front of this manual.



For maximum safety and to guarantee optimum product reliability, always use genuine **Tiger** replacement parts. The use of inferior replacement parts may cause premature or catastrophic failure which could result in serious injury or death.

Direct any questions regarding parts to:

Tiger Corporation
3301 N. Louise Ave.
Sioux Falls, SD 57107
1-800-843-6849
1-605-336-7900

BOOM ASSY - BENGAL 22

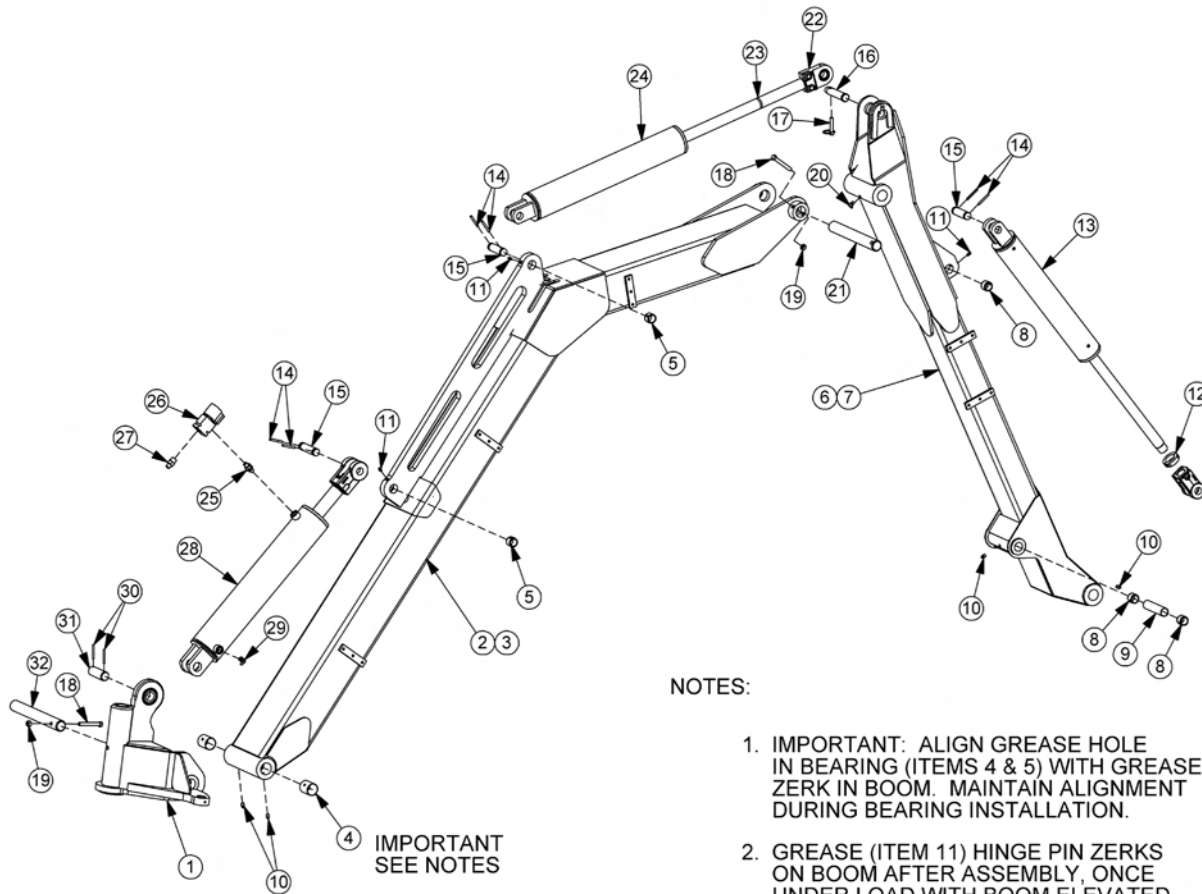

NOTES:

1. IMPORTANT: ALIGN GREASE HOLE IN BEARING (ITEMS 4 & 5) WITH GREASE ZERK IN BOOM. MAINTAIN ALIGNMENT DURING BEARING INSTALLATION.
2. GREASE (ITEM 11) HINGE PIN ZERKS ON BOOM AFTER ASSEMBLY, ONCE UNDER LOAD WITH BOOM ELEVATED AND AGAIN AT REST WITH BOOM SUPPORTED.

BOOM ASSY - BENGAL 22

Continued...

ITEM	PART NO.	QTY.	DESCRIPTION
1	-----	-	SWIVEL ASSY *REFER TO TRACTOR MOUNT KIT
2	24512	1	MAIN BOOM ARM ASSY
3	TB1002D	1	MAIN BOOM WLDMENT
4	32321	2	BUSHING, 1-1/2"ID X 2-1/2"
5	TB3010	2	BUSHING, 1"ID
6	24517	1	SECONDARY BOOM ARM ASSY
-----	06700098	-	SHORT SEC BOOM ARM ASSY (FOR 60" RTRY)
7	TB1001G	1	SECONDARY BOOM WLDMENT
8	TB3010	3	BUSHING, 1"ID
9	TB1035	1	BUSHING,SPACER
10	6T3211	4	GREASE ZERK,1/8"
11	6T3207	3	GREASE ZERK,1/4
12	35312	1	SET COLLAR
13	06501023	1	CYLINDER,3" X 18"
14	06537021	6	ROLL PIN,5MM
15	TB1033	3	PIN,1" X 4"
16	TB1036	1	PIN,1" X 4-11/16"
17	TF1143	1	PIN,LYNCH
18	21688	2	CAPSCREW,7/16" X 3-1/4",NC
19	21677	2	NYLOCK NUT,7/16",NC
20	6T3210	1	GREASE ZERK,1/8" X 90°
21	TB1025	1	PIN,1-1/2" X 12"
22	22076	1	SPACER,DECK LIFT CYL
23	06501024	1	CYLINDER,3-1/2" X 20"
24	31329	1	ADAPTER,1/2ORB X 1/2ORB ADJ
25	06510050	1	TRAVEL LOCK,METRIPACK COIL
26	33271	1	ADAPTER,1/2ORB X 1/2ORB ADJ
27	06501022	1	CYLINDER,4" X 20"
28	32810	1	ELBOW,1/2ORB X 3/8MJ90 ADJ
29	TB1023	2	ROLL PIN,7/32"
30	06420100	1	PIN,1-1/4" X 3-5/8"
31	TB3013C	1	PIN,1-1/2" X 12-3/4"

COMMON TRUCKAT/RAILKUT

BOOM HYD ASSY - BENGAL 22

NOTES:

1. PRESSURE AND RETURN LINES ARE OPPOSITE AS SHOWN FOR STANDARD ROTATION BOOM FLAIL MOWERS.

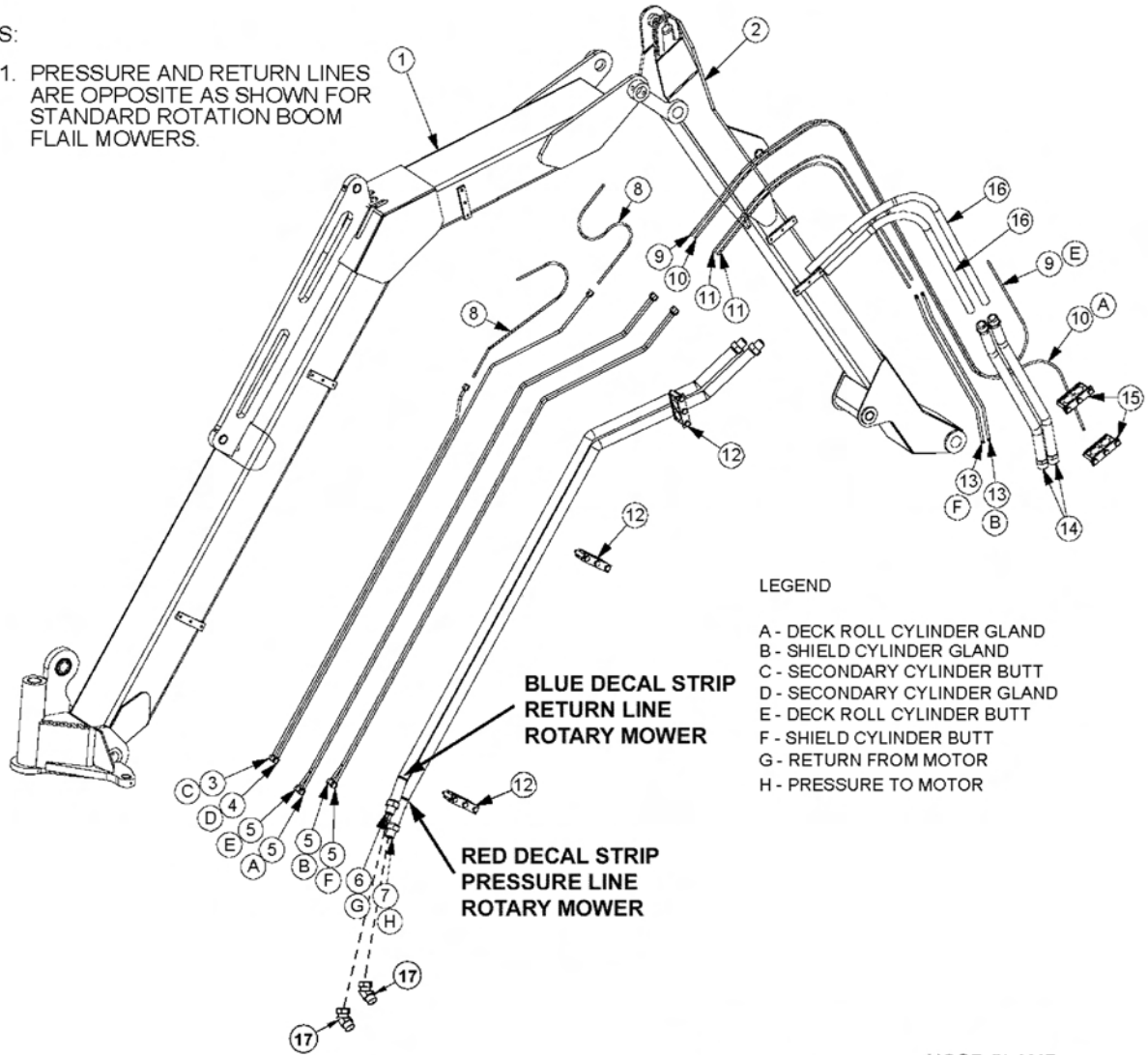

LEGEND

- A - DECK ROLL CYLINDER GLAND
- B - SHIELD CYLINDER GLAND
- C - SECONDARY CYLINDER BUTT
- D - SECONDARY CYLINDER GLAND
- E - DECK ROLL CYLINDER BUTT
- F - SHIELD CYLINDER BUTT
- G - RETURN FROM MOTOR
- H - PRESSURE TO MOTOR

**BLUE DECAL STRIP
RETURN LINE
ROTARY MOWER**

**RED DECAL STRIP
PRESSURE LINE
ROTARY MOWER**

HOSE CLAMP
ITEM 12

HOSE CLAMP
ITEM 15

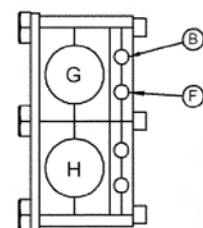
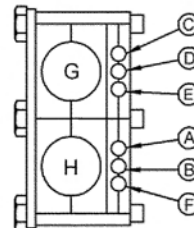

BOOM HYD ASSY - BENGAL 22

Continued...

ITEM	PART NO.	QTY.	DESCRIPTION
1	-----	-	MAIN BOOM *REFER TO BOOM ARM ASSY
2	-----	-	SECONDARY BOOM *REFER TO BOOM ARM ASSY
3	TB2025	1	PRFRMD TUBE #304
4	TB2026	1	PRFRMD TUBE #305
5	TB2028	4	PRFRMD TUBE #307
6	24035A	1	PRFRMD TUBE,MAIN BOOM RETURN
7	24034A	1	PRFRMD TUBE,MAIN BOOM PRESSURE
8	34052	2	HOSE,1/4" X 20"
9	34078	1	HOSE,1/4" X 48"
10	34079	1	HOSE,1/4" X 68"
11	34104	2	HOSE,1/4" X 42"
12	33440	3	TUBE CLAMP, MAIN BOOM (ROTARY MOWERS)
-----	30111	3	TUBE CLAMP,MAIN BOOM (FLAIL MOWERS)
13	34102	2	TUBE,PRFRMD,SEC BOOM
14	2403306	2	TUBE,PRFRMD,SEC BOOM,HP
15	30111	2	TUBE CLAMP,SEC BOOM (ROTARY MOWERS)
-----	30112	2	TUBE CLAMP,SEC BOOM (FLAIL MOWERS)
16	24488	2	HOSE,1" X 40"
17	24724	2	SWIVEL,1MJ X 1FJX45

COMMON TRUCKAT/RAILKUT

BOOM ROTARY PIVOT ASSEMBLY

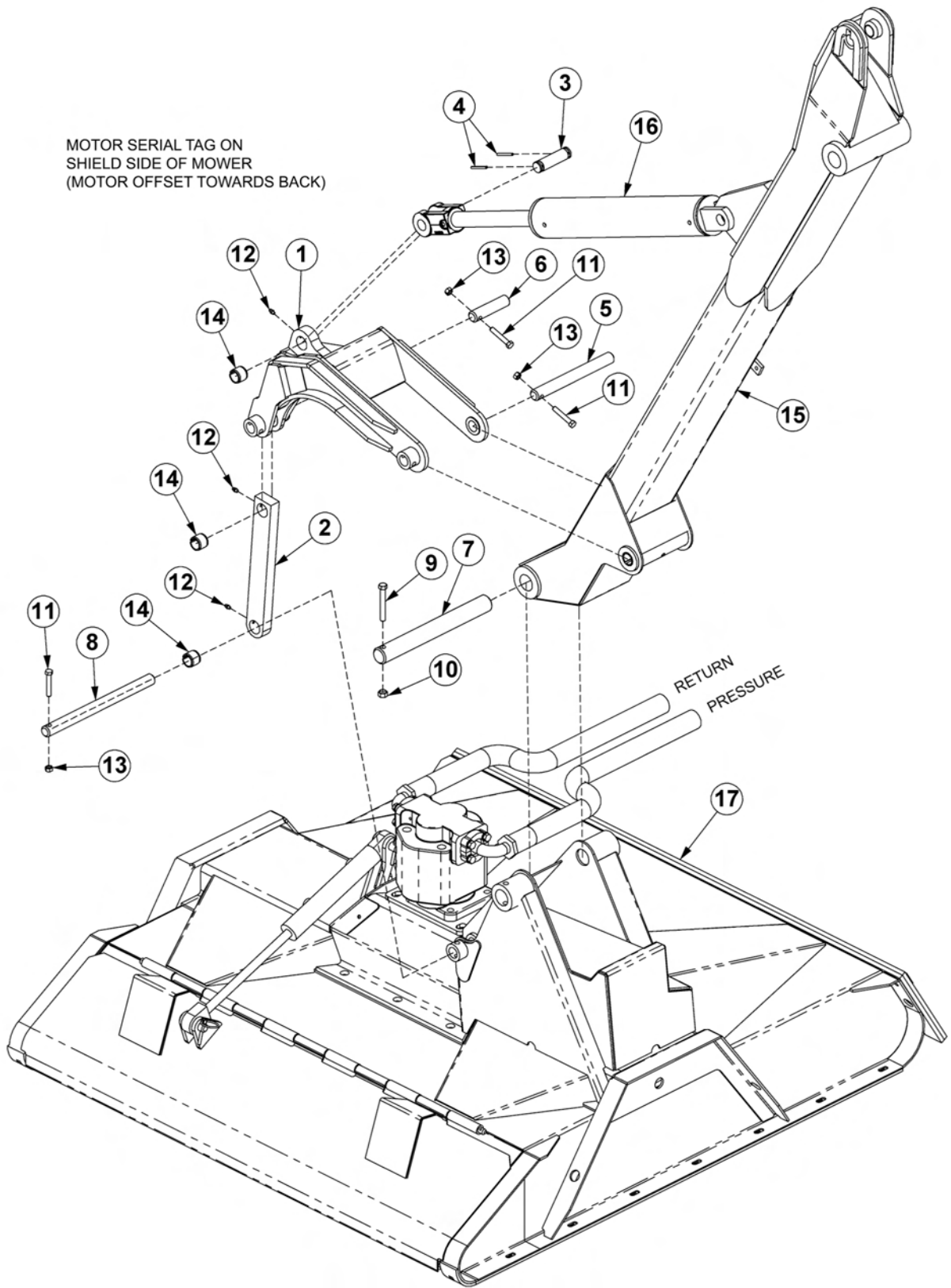

BOOM ROTARY PIVOT ASSEMBLY

Continued...

ITEM	PART NO.	QTY.	DESCRIPTION
1	TB1032	1	ROTARY PIVOT ASSY
2	TB1028	1	PIVOT ARM ASSY
3	TB1033	1	PIN,CLEVIS
4	06537021	2	ROLL PIN
5	TF3097	1	PIN
6	TB1030	1	PIN
7	33985	1	PIN
8	33986	1	PIN
9	21688	1	CAPSCREW,7/16 X 3-1/4,NC
10	21677	1	NYLOCK NUT,7/16 NC
11	21635	3	CAPSCREW,3/8 X 2-1/4
12	6T3207	3	GREASE ZERK
13	21627	3	NYLOCK NUT,3/8,NC
14	TB3010	3	BUSHING
15	-----	-	SECONDARY BOOM *REFER TO BOOM ARM ASSY
16	-----	-	CYLINDER *REFER TO BOOM ARM ASSY
17	-----	-	ROTARY MOWER HEAD *REFER TO ROTARY DECK

COMMON TRUCKAT/RAILKUT

BOOM FLAIL PIVOT ASSEMBLY

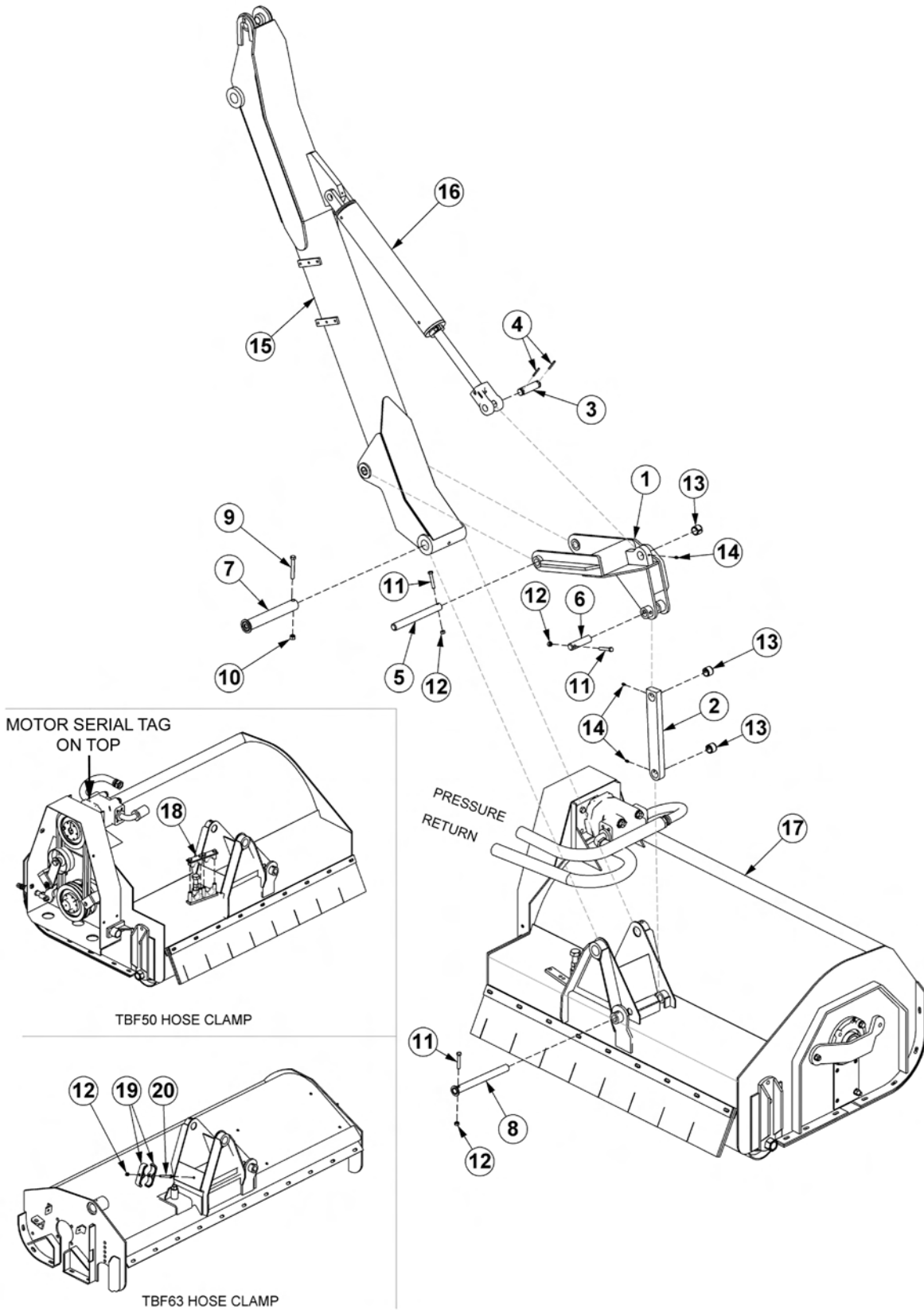

BOOM FLAIL PIVOT ASSEMBLY

Continued...

ITEM	PART NO.	QTY.	DESCRIPTION
1	TF3015	1	FLAIL PIVOT ASSY
2	TB1028	1	PIVOT ARM ASSY
3	TB1033	1	PIN CLEVIS
4	06537021	2	ROLL PIN
5	TF3097	1	PIN
6	TF3090	1	PIN
7	TB1024	1	PIN
8	TB1027	1	PIN
9	21688	1	CAPSCREW 7/16" X 3 1/4"
10	21677	1	NYLOCK NUT 7/16"
11	21635	3	CAPSCREW 3/8" X 2 1/4"
12	21627	4	NYLOCK NUT 3/8"
13	TB3010	3	BUSHING
14	6T3207	3	GREASE ZERK
15	-----	-	SECONDARY BOOM *REFER TO BOOM ARM ASSY
16	-----	-	CYLINDER *REFER TO BOOM ARM ASSY
17	-----	-	FLAIL MOWER HEAD *REFER TO FLAIL ASSY
18	31723	1	CLAMP KIT,TBF50 (USED ON 50" FLAIL)
19	TB3031	2	DOUBLE HOSE CLAMP (USED ON THE 63" FLAIL)
20	21638	1	CAPSCREW 3/8" X 3"

50IN ROTARY MOWER ASSEMBLY

LINK TO THE SHIELD (OPTIONAL)

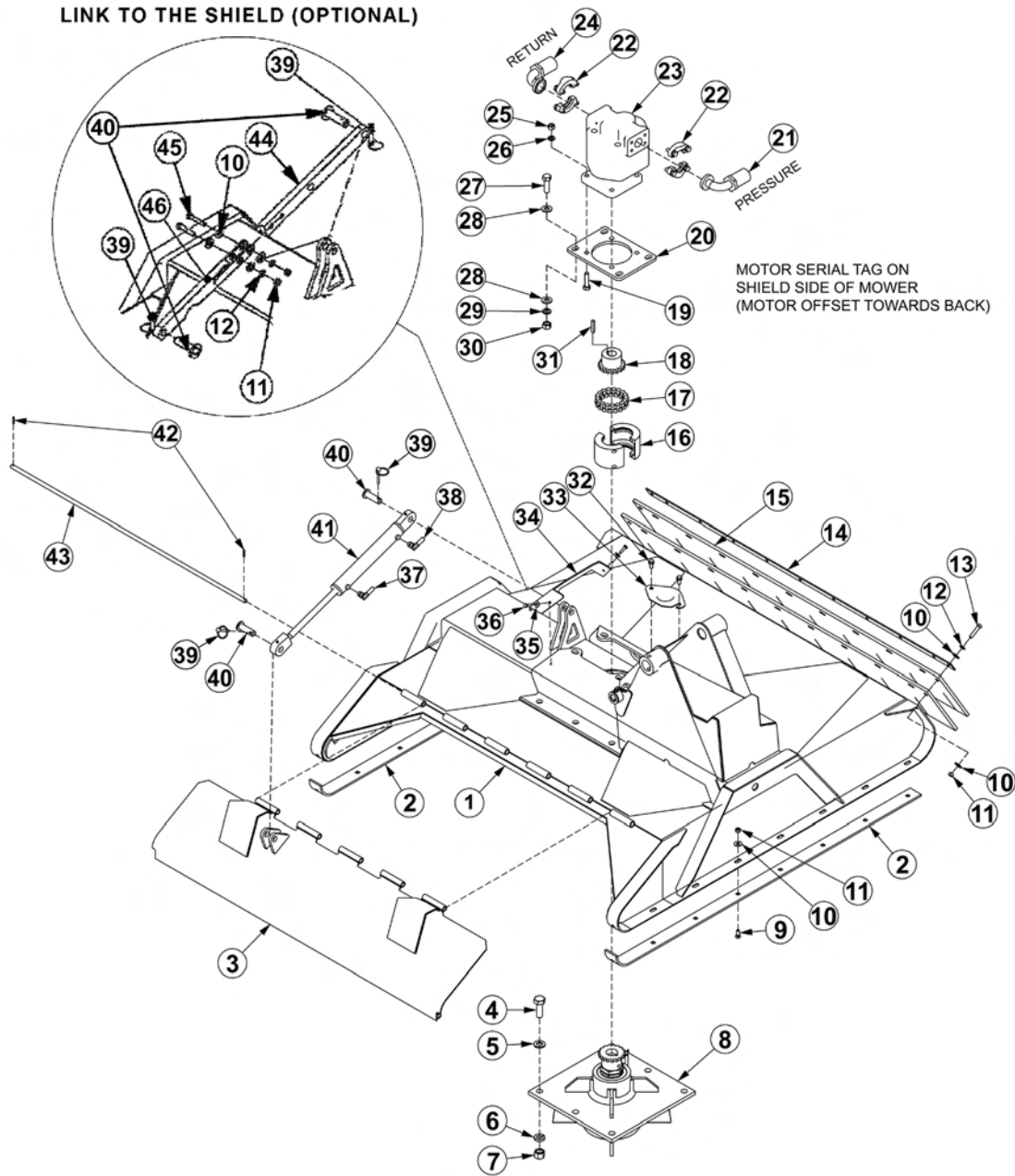

ITEM	PART NO.	QTY.	DESCRIPTION
1	33780	1	DECK,WLDMNT,50" RTRY
2	33777	2	SKID SHOE,50" RTRY
3	33754	1	SHIELD,50"RTRY
4	33879	6	CAPSCREW, 3/4 X 2 1/4,NF GR 8
5	33880	6	FLATWASHER,3/4",GR 8,SAE
6	21993	6	LOCKWASHER,3/4",GR 8
7	6T2413	6	HEX NUT,3/4,NF,GR 8
8	6T1024H5	1	SPINDLE ASSY,CPLT,HD,5/8 HOLES

COMMON TRUCKAT/RAILKUT

50IN ROTARY MOWER ASSEMBLY

Continued...

ITEM	PART NO.	QTY.	DESCRIPTION
9	6T2270	16	PLOW BOLT,3/8" X 1" NC
10	22016	33	FLATWASHER,3/8"
11	21625	20	HEX NUT,3/8",NC
12	21988	11	LOCKWASHER, 3/8"
13	21633	11	CAPSCREW, 3/8 X 1 3/4,NC
14	33774	1	FLAP RETAINER,50" RTRY
15	33775	2	FLAP,50" RTRY
16	6T1033	1	COUPLER COVER WITH HARDWARE AND SEALS
17	6T1029	1	COUPLER CHAIN
18	21223	1	SPROCKET
19	21733	4	CAPSCREW, 1/2 X 2,NC
20	33776	1	MOTOR MOUNT,PLATE,50" RTRY
21	24490	1	HOSE - PRESSURE (RED DECAL STRIP)
22	TF4852	2	FLANGE KIT - #20
23	06504012	1	MOTOR (M365-1 3/4" GEAR)
24	24489	1	HOSE - RETURN (BLUE DECAL STRIP)
25	21725	4	HEX NUT, 1/2" NC
26	06533004	4	FLATWASHER, 1/2"
27	6T2290	4	CAPSCREW,5/8X2,NF GR 8
28	33764	8	FLATWASHER,5/8",GR 8,SAE
29	21992	4	LOCKWASHER, 5/8
30	6T2408	4	HEX NUT, 5/8, NF
31	TF1124	1	SQUARE KEY
32	33881	2	CAPSCREW,FLG, 3/8 X 3/4,NC
33	33779	1	PLATE,COVER,KNF HOLE
34	06410439	1	COVER
35	22014	2	FLATWASHER,1/4
36	21530	2	CAPSCREW,1/4 X 1,NC
37	34187	1	HOSE 1/4" X 75"
38	34186	1	HOSE 1/4" X 66"
39	RD1032	2	LYNCH PIN
40	33984	2	PIN,SHIELD,50"
41	33785	1	1-1/2" X 8", CYLINDER, WELDED
42	6T3017	2	ROLLPIN
43	33778	1	HINGE PIN,50" RTRY
44	33772	1	LINK, SHIELD 50" RTRY (OPTIONAL)
45	21634	2	CAPSCREW, 3/8" X 2, NC
46	33773	1	LINK 2, SHIELD 50" RTRY (OPTIONAL)

COMMON TRUCKAT/RAILKUT

60IN ROTARY MOWER ASSEMBLY

LINK TO THE SHIELD (OPTIONAL)

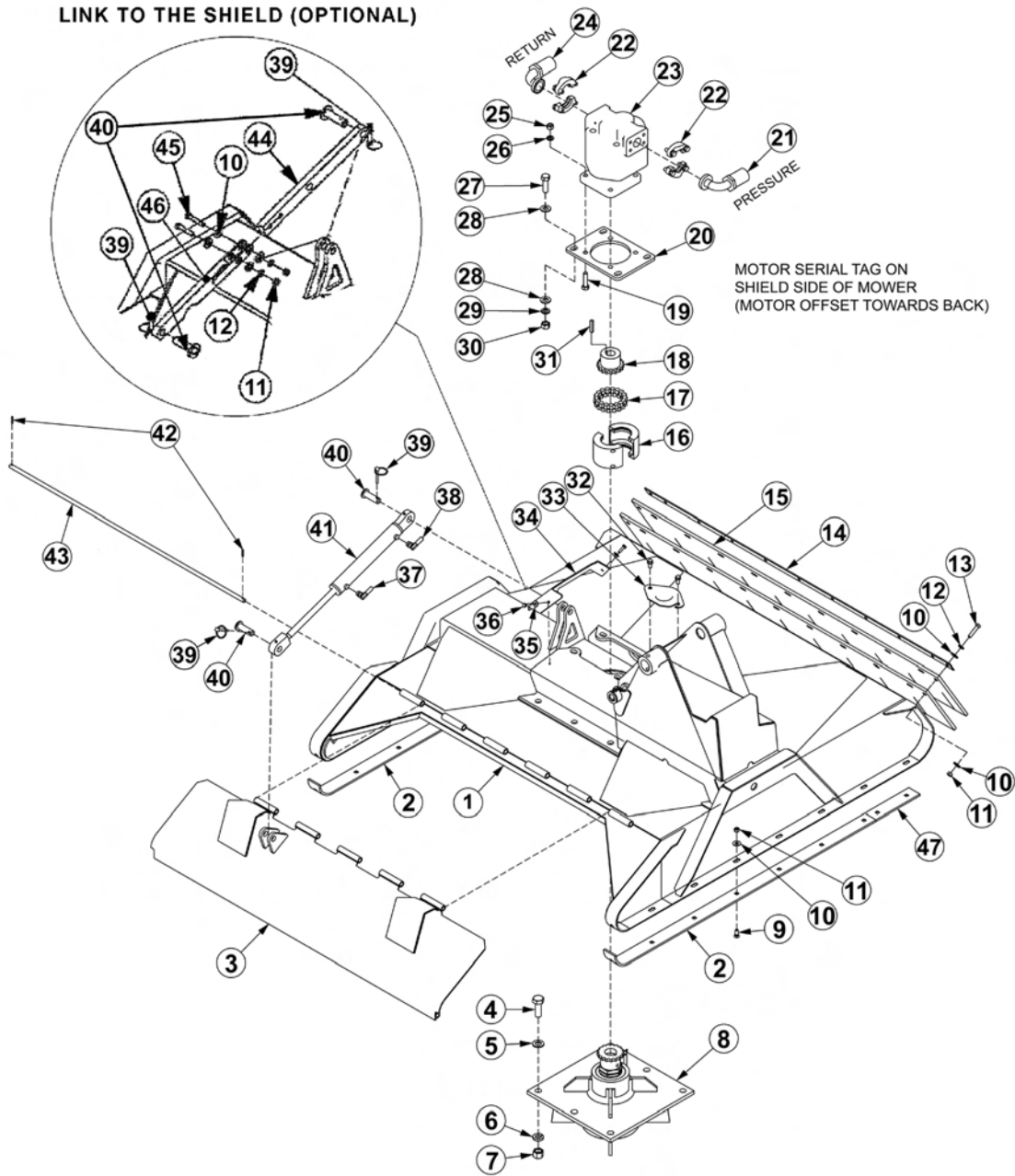

ITEM	PART NO.	QTY.	DESCRIPTION
1	06320159	1	DECK,WLDMNT,60" RTRY
2	33777	2	SKID SHOE,RTRY
3	06320162	1	SHIELD,60"RTRY
4	33879	6	CAPSCREW, 3/4" X 2 1/4",NF GR 8
5	33880	6	FLATWASHER,3/4",GR 8,SAE
6	21993	6	LOCKWASHER,3/4",GR 8
7	6T2413	6	HEX NUT,3/4",NF,GR 8
8	6T1024H5	1	SPINDLE ASSY,CPLT,HD,5/8" HOLES

COMMON TRUCKAT/RAILKUT

60IN ROTARY MOWER ASSEMBLY

Continued...

ITEM	PART NO.	QTY.	DESCRIPTION
9	6T2270	16	PLOW BOLT,3/8" X 1",NC
10	22016	33	FLATWASHER,3/8"
11	21625	20	HEX NUT,3/8",NC
12	21988	11	LOCKWASHER,3/8"
13	21633	11	CAPSCREW,3/8" X 1-3/4",NC
14	6T0823	1	FLAP RETAINER,60" RTRY
15	06520238	2	FLAP,60" RTRY
16	6T1033	1	COUPLER COVER WITH HARDWARE AND SEALS
17	6T1029	1	COUPLER CHAIN
18	21223	1	SPROCKET
19	21733	4	CAPSCREW,1/2" X 2",NC
20	33776	1	MOTOR MOUNT,PLATE,RTRY
21	24490	1	HOSE - PRESSURE (RED DECAL STRIP)
22	TF4852	2	FLANGE KIT - #20
23	06504011	1	MOTOR
24	24489	1	HOSE - RETURN (BLUE DECAL STRIP)
25	21725	4	HEX NUT, 1/2" NC
26	06533004	4	FLATWASHER, 1/2"
27	6T2290	4	CAPSCREW,5/8" X 2",NF GR 8
28	33764	8	FLATWASHER,5/8",GR 8,SAE
29	21992	4	LOCKWASHER,5/8"
30	6T2408	4	HEX NUT,5/8", NF
31	TF1124	1	SQUARE KEY
32	33881	4	CAPSCREW,FLG,3/8" X 3/4",NC
33	33779	2	PLATE,COVER,KNF HOLE
34	06410439	1	COVER
35	22014	2	FLATWASHER,1/4"
36	21530	2	CAPSCREW,1/4" X 1",NC
37	34187	1	HOSE 1/4" X 75"
38	34186	1	HOSE 1/4" X 66"
39	RD1032	2	LYNCH PIN
40	33984	2	PIN,SHIELD
41	33785	1	1-1/2" X 8", CYLINDER, WELDED
42	6T3017	2	ROLLPIN
43	06420139	1	HINGE PIN,60" RTRY
44	33772	1	LINK, SHIELD,RTRY (OPTIONAL)
45	21634	2	CAPSCREW, 3/8" X 2", NC
46	33773	1	LINK 2, SHIELD,RTRY (OPTIONAL)
47	06401245	2	SKID SHOE,TRB60"

COMMON TRUCKAT/RAILKUT

50IN ROTARY KNIVES AND DISH

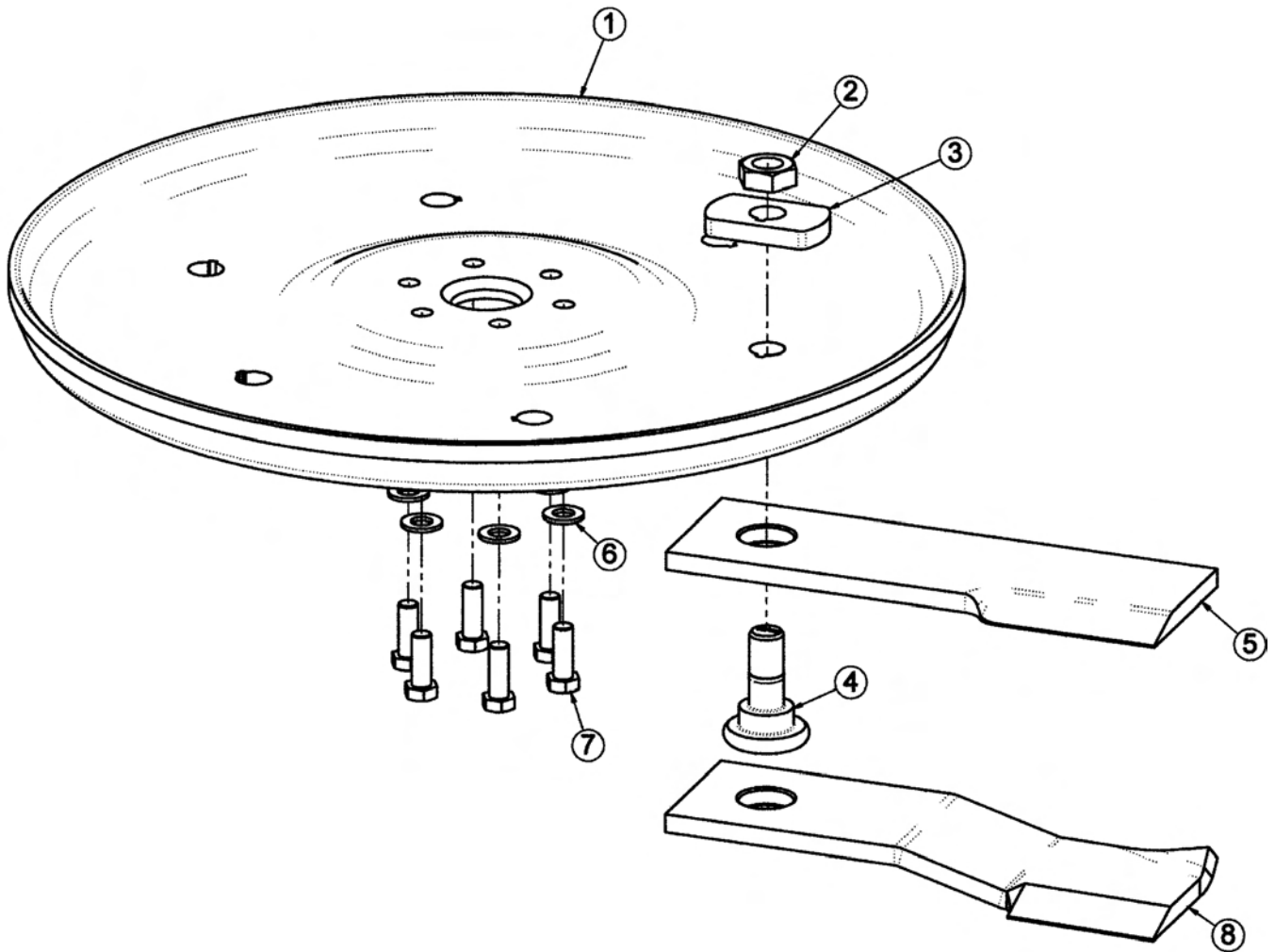

ITEM	PART NO.	QTY.	DESCRIPTION
-----	06700089	-	KIT,TRB50,DISK,W/BOLT KIT (INCLUDES ITEMS 1,3 & 7)
1	06770003	1	BLADE MOUNTING DISK
2	6T1023R	2	NYLOCK HEX NUT 1 1/8"
3	34878	2	SPACER
4	06538000	2	KNIFE MOUNTING BOLT
5	06521001	2	STANDARD KNIFE
6	33764	6	FLATWASHER
7	6T2259	6	CAPSCREW
-----	06770012	-	BOLT KIT (INCLUDES ITEMS 6, 7 & LOCTITE)
8	06521002	2	GRASS KNIFE (OPTIONAL)
-----	6T1825	-	LOCTITE - USED ON ALL DISK MOUNTING BOLTS

60IN ROTARY BLADE BAR AND KNIVES

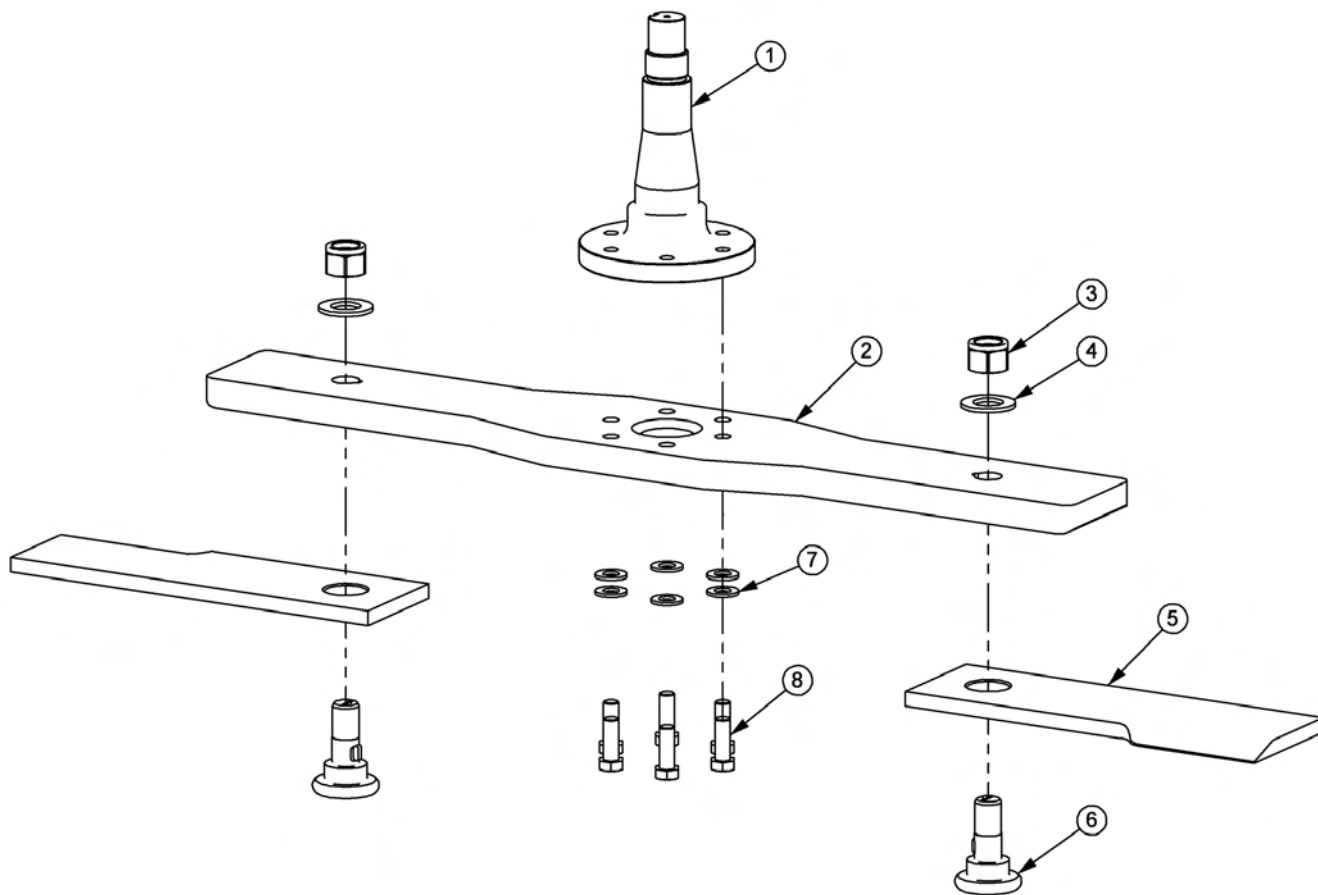

ITEM	PART NO.	QTY.	DESCRIPTION
1	PT1018H5	1	SPINDLE
2	06400690	1	BAR, BLADE, RTRY60
3	6T1023R	2	KNIFE MTG NUT, 1-1/8, NYLOCK, NF
4	06533002	2	FLATWASHER, 1-1/8, GR8
5	06521001	2	KNIFE, TRB50, 5/8
6	06538000	2	KNIFE MTG BOLT, 5/8 SHOULDER
7	33764	6	FLATWASHER, 5/8, GR 8, SAE
8	6T2259	6	CAPSCREW, 5/8 X 1-3/4, NF, GR8

60IN ROTARY KNIVES AND DISH

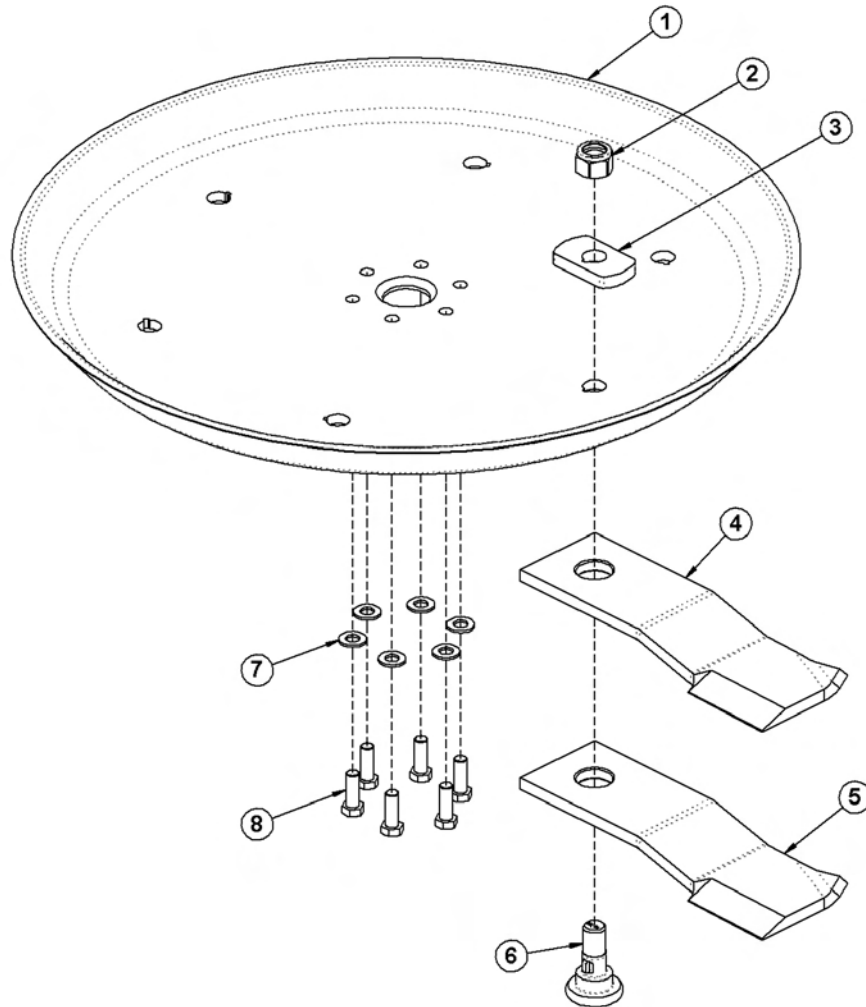

ITEM	PART NO.	QTY.	DESCRIPTION
1	34876	1	BLADE MOUNTING DISH,60"
2	6T1023R	2	NYLOCK NUT,1-1/8",NF
3	34878	2	SPACER
4	34684	2	STANDARD GRASS KNIFE
5	34685	2	HIGH SUCTION GRASS KNIFE (OPTIONAL)
6	34497	2	KNIFE MOUNTING BOLT
7	25270	6	FLATWASHER,5/8,GR8,USS
8	6T2259	6	CAPSCREW,5/8" X 1-3/4",NF,GR8
---	6T1825	1	LOCTITE (USED ON ITEM 8)
---	27167	-	BOLT KIT (INCLUDES ITEMS 7 & 8)
---	33893	-	KNIFE KIT (INCLUDES ITEMS 2, 4 & 6)

COMMON TRUCKAT/RAILKUT

NOTES

NOTES

ROTARY MOWER SPINDLE ASSEMBLY

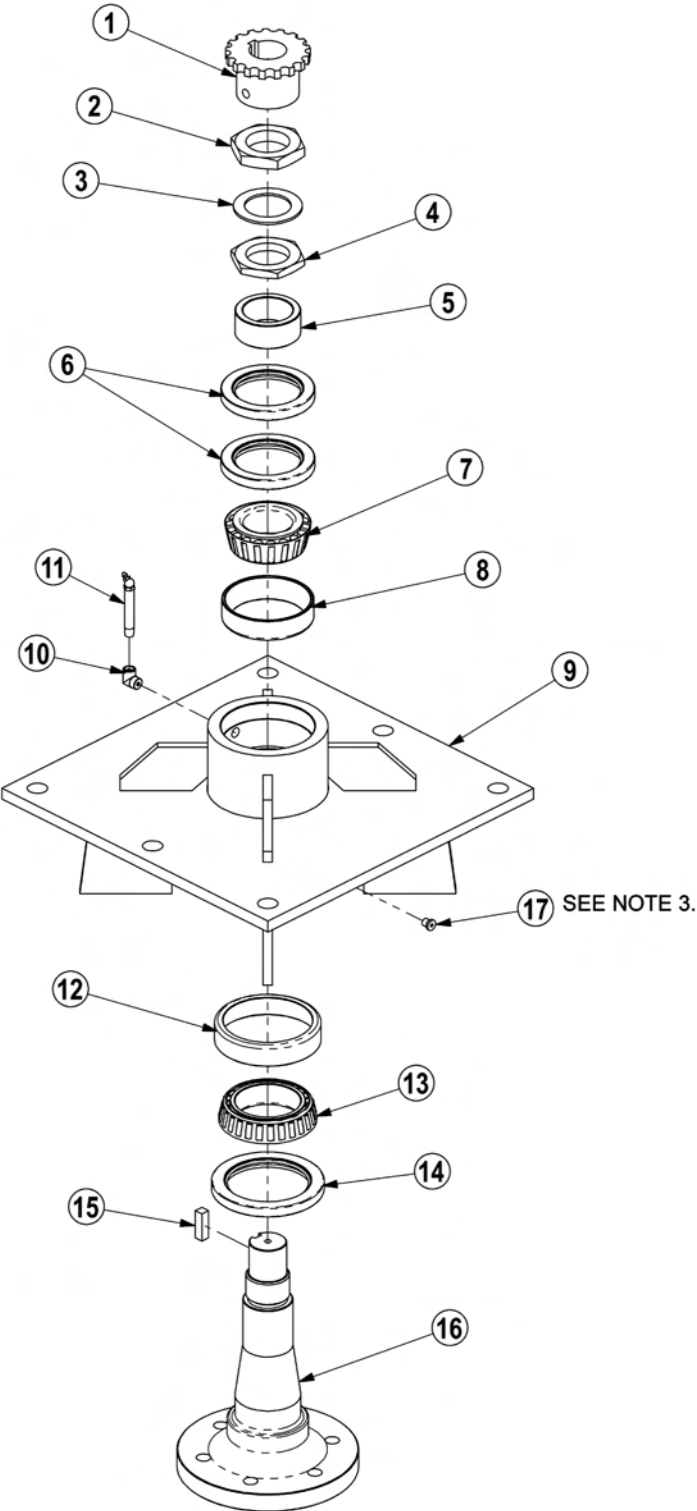

- NOTES:
1. FREEPLAY: .001" - .003"
 2. GREASE: FILL WITH MOBILITH SHC 220.
 3. APPLY LOCTITE "271" TO O-RING PLUG THRDS.

ROTARY MOWER SPINDLE ASSEMBLY

Continued...

ITEM	PART NO.	QTY.	DESCRIPTION
-----	6T1024H5	-	SPINDLE ASSEMBLY COMPLETE
1	6T1031	1	SPROCKET
2	6T1016	1	BEARING LOCK NUT - THICK
3	22596	1	JAM WASHER
4	6T1015	1	BEARING ADJUSTMENT NUT - THIN
5	6T1014	1	BEARING ADJUSTMENT SLEEVE
6	6T1011	1	UPPER SEAL - SET OF 2
7	6T1012	1	BEARING CONE
8	6T1013	1	BEARING CUP
9	6T1010H	1	SPINDLE HOUSING
10	30570	1	FITTING STREET ELBOW
11	33990	1	GREASE ZERK
12	6T1013H	1	BEARING CUP
13	6T1012H	1	BEARING CONE
14	6T1011H	1	LOWER SEAL
15	6T1019	1	SPINDLE KEY
16	PT1018H5	1	SPINDLE
17	06503064	1	O-RING PLUG, 1/8"
-----	31771	-	SPINDLE REBUILD KIT (INCLUDES ITEMS 2 - 8 AND 12 - 15)

COMMON TRUCKAT/RAILKUT

50IN FLAIL DRIVE ASSEMBLY

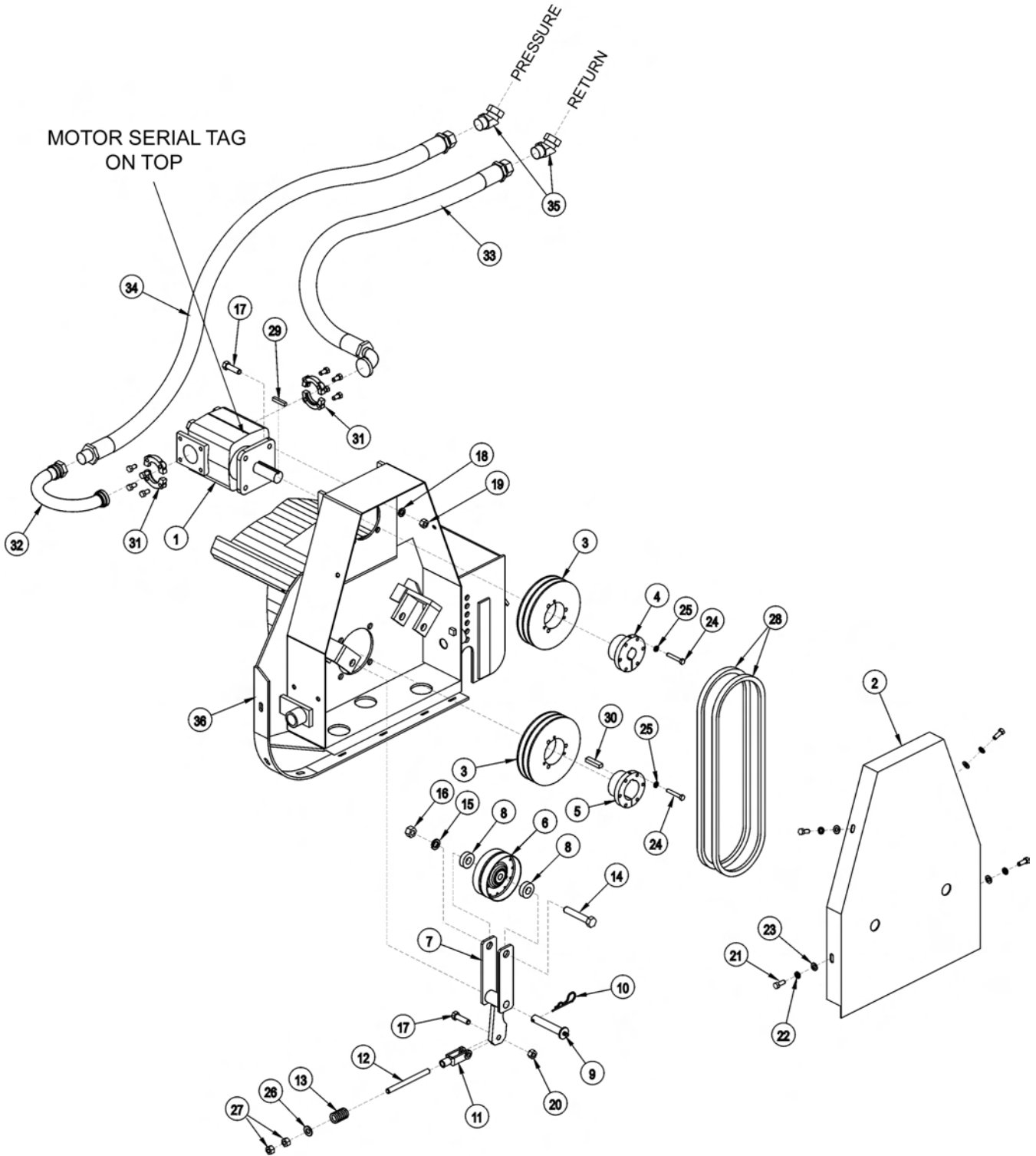

50IN FLAIL DRIVE ASSEMBLY

Continued...

ITEM	PART NO.	QTY.	DESCRIPTION
1	06504013	1	MOTOR (M350-1 3/4" GEAR)
2	TF3006	1	BELT GUARD
3	TF3043	2	SHEAVE
4	TF3013	1	BUSHING
5	TF3011	1	BUSHING
6	TF3034	1	IDLER PULLEY
7	TF3205	1	IDLER ARM
8	TF3206	2	IDLER PULLEY SPACER
9	TF3605	1	IDLER ARM PIN WITH ZERK
10	6T3004	1	R - CLIP
11	PT3611A	1	CLEVIS
12	32481	1	THREADED ROD
13	TF3620	1	COMPRESSION SPRING
14	21789	1	CAPSCREW 5/8" X 3 1/2"
15	21992	1	LOCKWASHER 5/8"
16	21775	1	HEX NUT 5/8"
17	21732	5	CAPSCREW 1/2" X 1 3/4"
18	21990	4	LOCKWASHER 1/2"
19	21725	4	HEX NUT 1/2"
20	6T2418	1	LOCK NUT 1/2"
21	21630	4	CAPSCREW 3/8" X 1"
22	21988	4	LOCKWASHER 3/8"
23	22016	4	FLATWASHER 3/8"
24	21584	6	CAPSCREW 5/16" X 2"
25	21987	6	LOCKWASHER 5/16"
26	27938	1	FLATWASHER 1/2"
27	21700	2	HEX NUT 1/2" NF
28	TF3021	2	BELT
29	TF1125	1	SQUARE KEY
30	TF1025	1	SQUARE KEY MOTOR
31	TF4852	2	FLANGE KIT
32	31124	1	PREFORMED TUBE
33	31218	1	HOSE - RETURN
34	31219	1	HOSE - PRESSURE
35	24724	2	SWIVEL FITTING
36	-----	-	CUTTER HEAD *REFER TO CUTTER HEAD ASSY

COMMON TRUCKAT/RAILKUT

50IN FLAIL MOWER ASSEMBLY

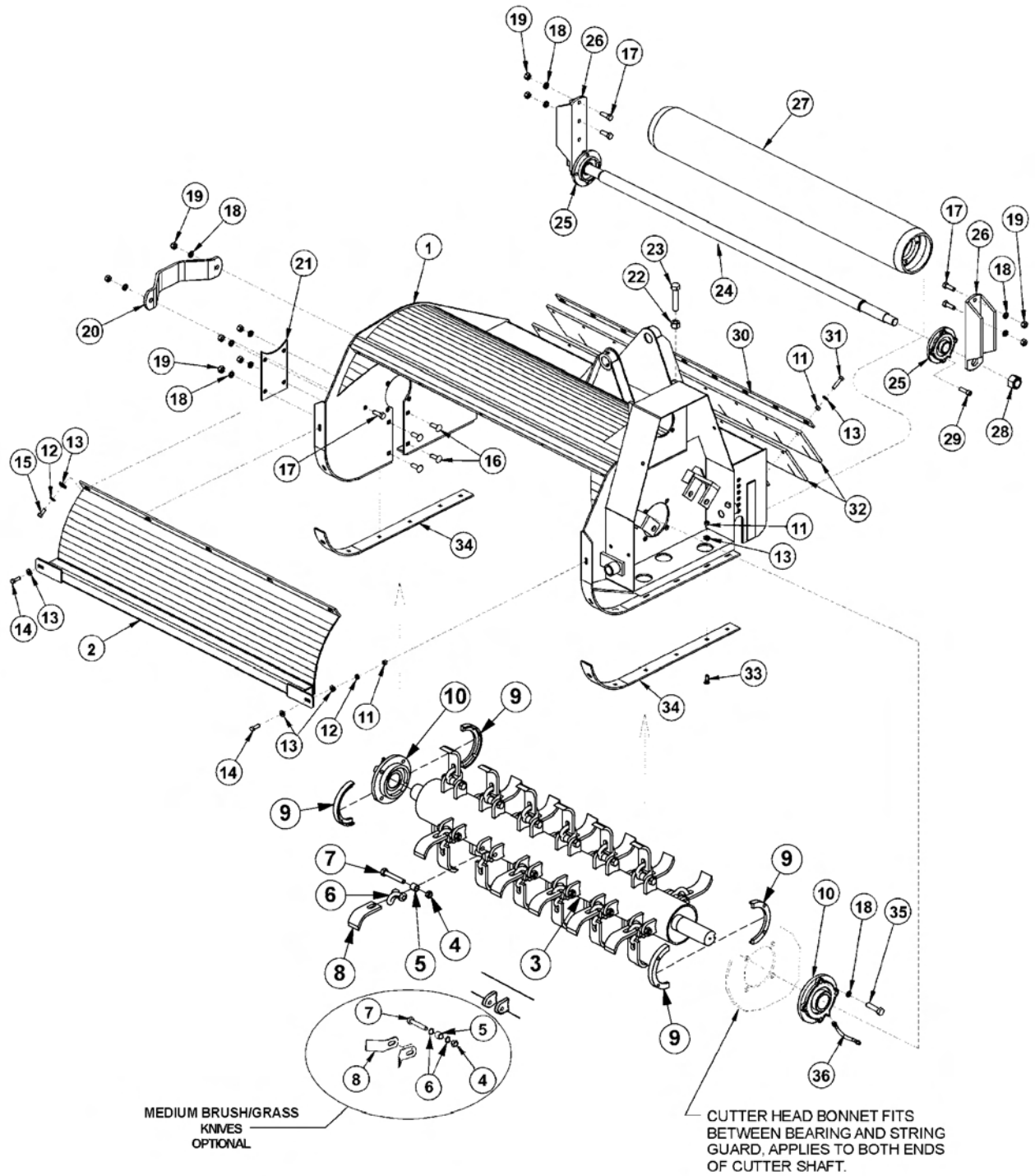

ITEM	PART NO.	QTY.	DESCRIPTION
---	34787	1	FLAIL,BOOM,50,BRUSH,CPLT ASSY (LIGHT BRUSH/GRASS)
----	06742133	1	FLAIL,BOOM,50,MD GRASS,CPLT ASSY (MEDIUM BRUSH/GRASS)
1	TF3003F	1	CUTTER HEAD BONNET
2	TF3004	1	FRONT SHIELD

COMMON TRUCKAT/RAILKUT

50IN FLAIL MOWER ASSEMBLY

Continued...

ITEM	PART NO.	QTY.	DESCRIPTION
3	34783	1	TBF50 (LIGHT BRUSH/GRASS KNIFE ASSY)
---	06700115	1	TBF50 (MEDIUM BRUSH/GRASS KNIFE ASSY)
4	6T2419	24	HEX NUT,9/16",NC,STOVER
5	41725.01HT	24	BUSHING,1"OD X 5/8"ID
6	34782	24	CLEVIS (LIGHT BRUSH/GRASS KNIVES)
---	06430122	48	SPACER (MEDIUM BRUSH/GRASS KNIVES)
7	34786	24	CAPSCREW,9/16" X 3-1/2",NC
8	34780	24	KNIFE (LIGHT BRUSH/GRASS CUTTING)
---	06521007	48	KNIFE (MEDIUM BRUSH/GRASS CUTTING)
9	31204	2	STRING GUARD SET (2 PIECES PER SET)
10	TF1018	2	FLANGE BEARING,2-3/16"
11	21625	23	HEX NUT,3/8",NC
12	21988	7	LOCKWASHER,3/8"
13	22016	30	FLATWASHER,3/8"
14	21631	2	CAPSCREW,3/8" X 1-1/4",NC
15	21630	5	CAPSCREW,3/8" X 1",NC
16	6T7031D	4	PLOW BOLT,1/2" X 1-1/2",NC
17	21731	6	CAPSCREW,1/2" X 1-1/2",NC
18	21990	18	LOCKWASHER,1/2"
19	21725	10	HEX NUT,1/2",NC
20	TF1040	1	CUTTER SHAFT GUARD
21	TF3007A	1	COVER PLATE
22	21825	1	HEX NUT,5/8",NC
23	21838	1	CAPSCREW,3/4" X 3-1/2",NC
24	TF3406	1	GROUND ROLLER TIE ROD
25	TF1022	2	FLANGE BEARING,1-3/8"
26	TF3407	2	GROUND ROLLER ADJUSTMENT BRACKET
27	TF3405	1	GROUND ROLLER
28	6T1023R	2	NYLOCK NUT,1-1/8",NF
29	6T2330	8	CAPSCREW,7/16" X 1-1/2",SOCKET HEAD
30	TB1008	1	FLAP RETAINING BAR
31	21633	9	CAPSCREW,3/8" X 1-3/4",NC
32	TB1006A	2	DEFLECTOR FLAP
33	6T2270	12	PLOWBOLT,3/8" X 1",NC
34	TF3001	2	SKID SHOE
35	06530218	8	CAPSCREW,1/2" X 1-3/4",NC
36	TF1032	1	FLANGE BEARING GREASE HOSE

COMMON TRUCKAT/RAILKUT

63IN FLAIL DRIVE ASSEMBLY

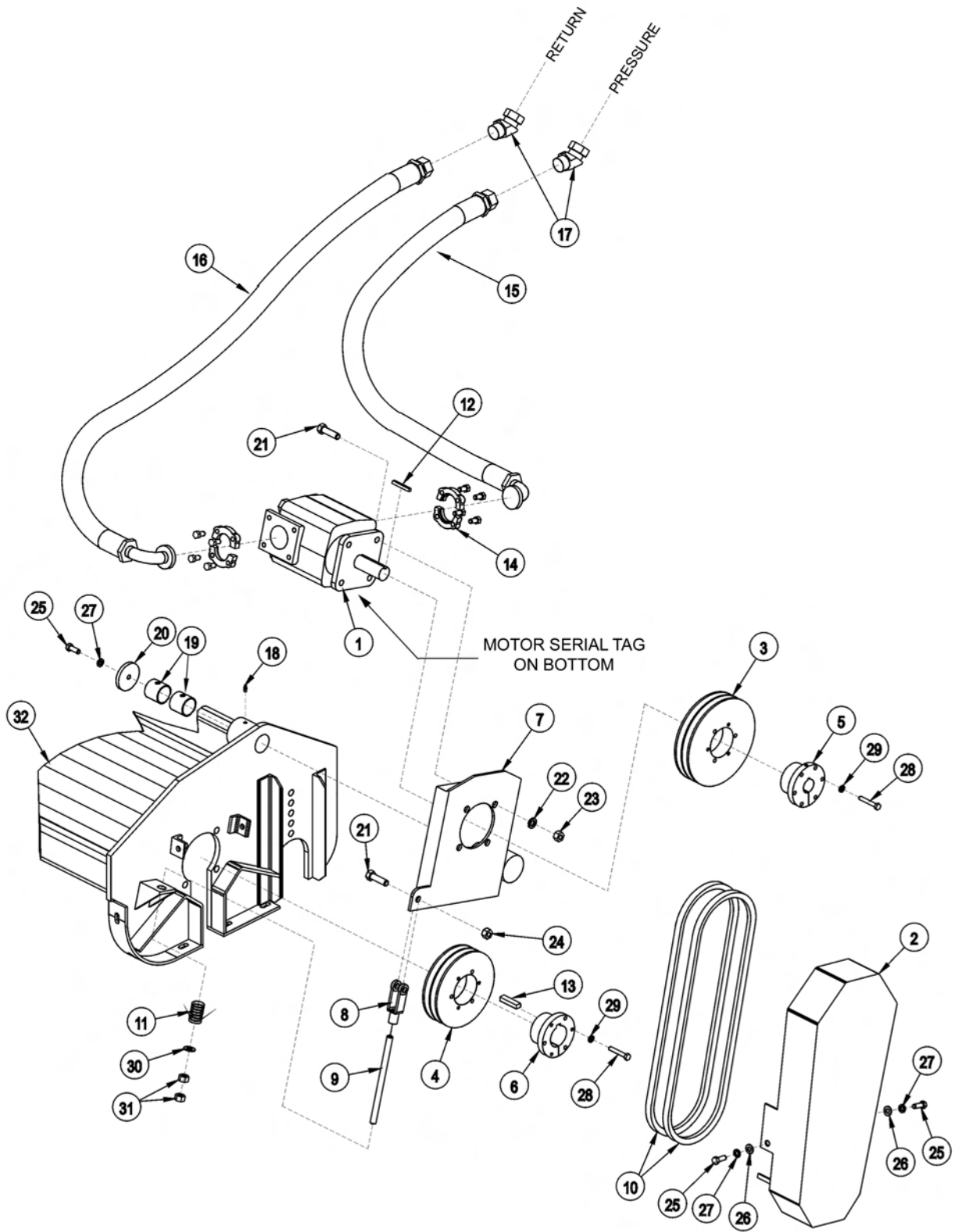

63IN FLAIL DRIVE ASSEMBLY

Continued...

ITEM	PART NO.	QTY.	DESCRIPTION
1	06504013	1	MOTOR (M350-1 3/4 GEAR)
2	32569	1	BELT GUARD
3	TF3044	1	UPPER SHEAVE
4	TF3040	1	LOWER SHEAVE
5	TF3013	1	BUSHING
6	28723	1	BUSHING
7	28679B	1	MOTOR CHANNEL
8	PT3611A	1	CLEVIS
9	40496	1	THREADED ROD
10	28702	2	BELT
11	TF3620A	1	TENSIONER SPRING
12	28572	1	SQUARE KEY
13	26142A	1	SQUARE KEY
14	TF4852	2	FLANGE KIT
15	30308	1	HOSE,1 X 69 - PRESSURE
16	30309	1	HOSE,1 X 78 - RETURN
17	24724	2	SWIVEL FITTING
18	TF1033	1	GREASE ZERK
19	27580	2	BUSHING
20	28682	1	MOTOR CHANNEL WASHER
21	21732	5	CAPSCREW 1/2" X 1 3/4"
22	21990	4	LOCKWASHER 1/2"
23	21725	4	HEX NUT 1/2"
24	6T2418	1	STOVER NUT 1/2"
25	21630	3	CAPSCREW 3/8" X 1"
26	22016	2	FLATWASHER 3/8"
27	21988	3	LOCKWASHER 3/8"
28	21584	6	CAPSCREW 5/16" X 2"
29	21987	6	LOCKWASHER 5/16"
30	27938	1	FLATWASHER 1/2"
31	21700	2	HEX NUT 1/2" NF
32	-----	-	CUTTER HEAD *REFER TO MOWER ASSY

COMMON TRUCKAT/RAILKUT

63IN FLAIL MOWER ASSEMBLY

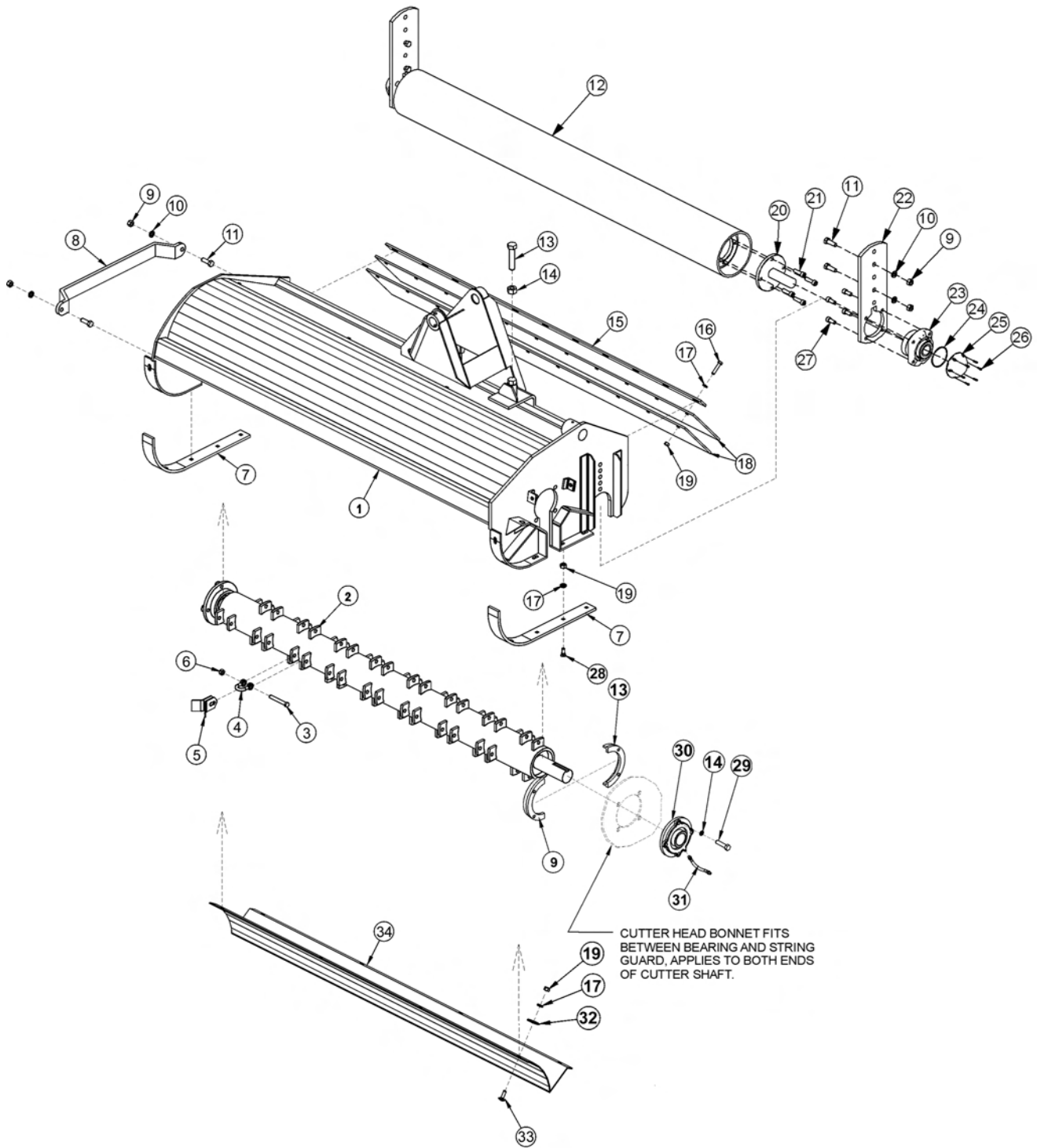

63IN FLAIL MOWER ASSEMBLY

Continued...

ITEM	PART NO.	QTY.	DESCRIPTION
-----	06200271	-	FLAIL,BOOM,63,GRASS,CPLT ASSY
1	28659H	1	CUTTER HEAD BONNET
2	28743	-	CUTTER SHAFT / KNIFE ASSY STANDARD GRASS
-----	28642C	1	CUTTER SHAFT,63,STD
3	34011	36	FLAIL KNIFE MOUNTING BOLT
4	TF1020	36	FLAIL KNIFE MOUNTING CLEVIS
5	33713	72	FLAIL KNIFE - STANDARD
6	21677	36	NYLOCK NUT
7	28086A	2	SKID SHOE
8	27975A	1	CUTTER SHAFT GUARD
9	21725	14	HEX NUT 1/2"
10	21990	14	LOCKWASHER 1/2"
11	21731	6	CAPSCREW 1/2" X 1 1/2"
12	28650A	1	GROUND ROLLER
13	33863	2	STRING GUARD,STD
14	06533006	8	FLATWASHER,1/2",SAE,L9
15	28700	1	FLAP RETAINING BAR
16	21633	11	CAPSCREW 3/8" X 1 3/4"
17	21988	28	LOCKWASHER 3/8"
18	28701	2	DEFLECTOR FLAP
19	21625	28	HEX NUT 3/8"
20	TF1045B	2	GROUND ROLLER STUB SHAFT
21	6T2330	8	CAPSCREW 7/16" X 1 1/2" SOCKET HEAD
22	28735	2	ADJUSTABLE ROLLER BRACKET
23	06520028	2	BEARING,FLANGE,1-3/8,GRNDRLLR
24	06520029	2	O-RING
25	06520027	2	CAP,BEARING,GROUNDROLLER
26	06530001	12	CAPSCREW,SKT HD,8-32 X 1/2,SS
27	6T2331	8	CAPSCREW 7/16" X 1" SOCKET HEAD
28	6T2270	10	PLOW BOLT 3/8" X 1 1/4"
29	06530217	8	CAPSCREW 1/2" X 2",L9
30	28683	2	FLANGE BEARING
31	TF1032	1	FLANGE BEARING GREASE HOSE
32	6T2615	7	FENDER WASHER 3/8"
33	6T2283	7	CARRIAGE BOLT 3/8" X 1"
34	28665A	1	BAFFLE (INSIDE UPPER REAR OF CUTTER HEAD)

COMMON TRUCKAT/RAILKUT

3IN X 17-1/2IN WELDED CYLINDER BREAKDOWN

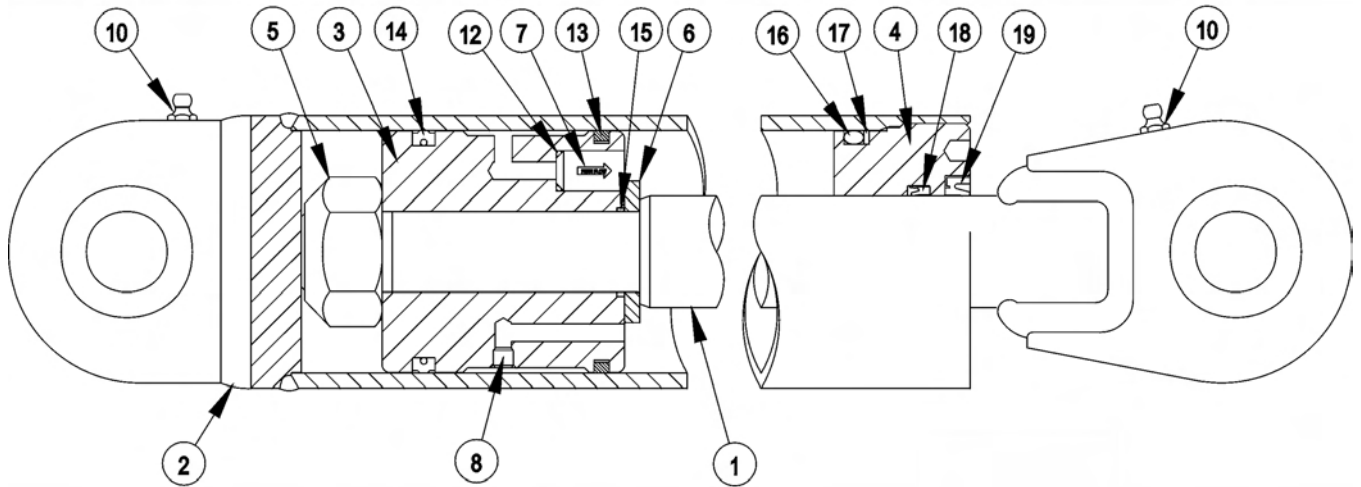

WARNING - MECHANICAL FASTENERS MUST BE TORQUED TO RECOMMENDED SPECIFICATIONS DURING REPAIR TO PREVENT PERSONAL INJURY OR EQUIPMENT DAMAGE.

ITEM	PART NO.	QTY.	DESCRIPTION
---	33705	-	CYLINDER,WELDED,3" X 17-1/2"
1	34571	1	PISTON ROD ASSY
2	34572	1	BUTT & TUBE ASSY
3	34573	1	PISTON
4	34574	1	GLAND
5	34575	1	LOCK NUT,1"-14 UNS (TORQUE TO 315 FT.LB.)
6	34576	1	SPACER
7	34577	1	CHECK VALVE,KEPNER
8	34578	1	ORIFICE
9	33761	1	SEAL KIT,PACKING (ITEMS 12 THRU 19)
10	-----	2	GREASE ZERK
12	-----	1	O - RING
13	-----	1	CAST IRON PISTON RING
14	-----	1	CROWN SEAL
15	-----	1	O - RING
16	-----	1	O - RING
17	-----	1	BACK - UP WASHER
18	-----	1	U - CUP
19	-----	1	WIPER
20	34334	-	SPHERICAL BEARING (NOT SHOWN)

3IN X 18IN WELDED CYLINDER BREAKDOWN

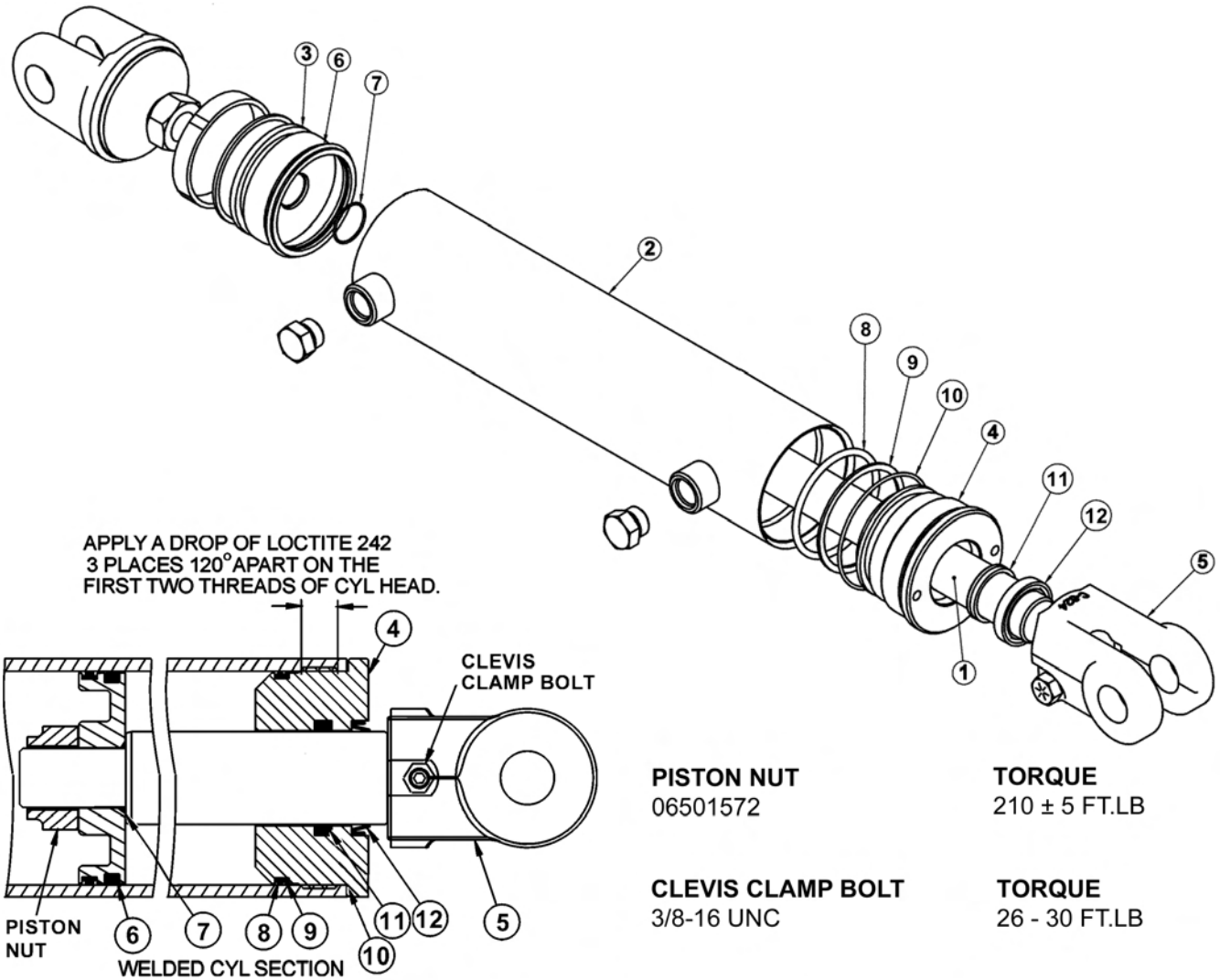

WARNING - MECHANICAL FASTENERS MUST BE TORQUED TO RECOMMENDED SPECIFICATIONS DURING REPAIR TO PREVENT PERSONAL INJURY OR EQUIPMENT DAMAGE.

ITEM	PART NO.	QTY.	DESCRIPTION
-----	06501023	-	HYDRAULIC CYLINDER COMPLETE
1	06501561	1	ROD
2	06501562	1	TUBE WELDMENT
3	06501552	1	PISTON
4	06501563	1	CYLINDER HEAD
5	06501554	1	CLEVIS
-----	06501564	-	SEAL REPAIR KIT (ITEMS 6 THROUGH 12)

3-1/2IN X 20IN WELDED CYLINDER BREAKDOWN

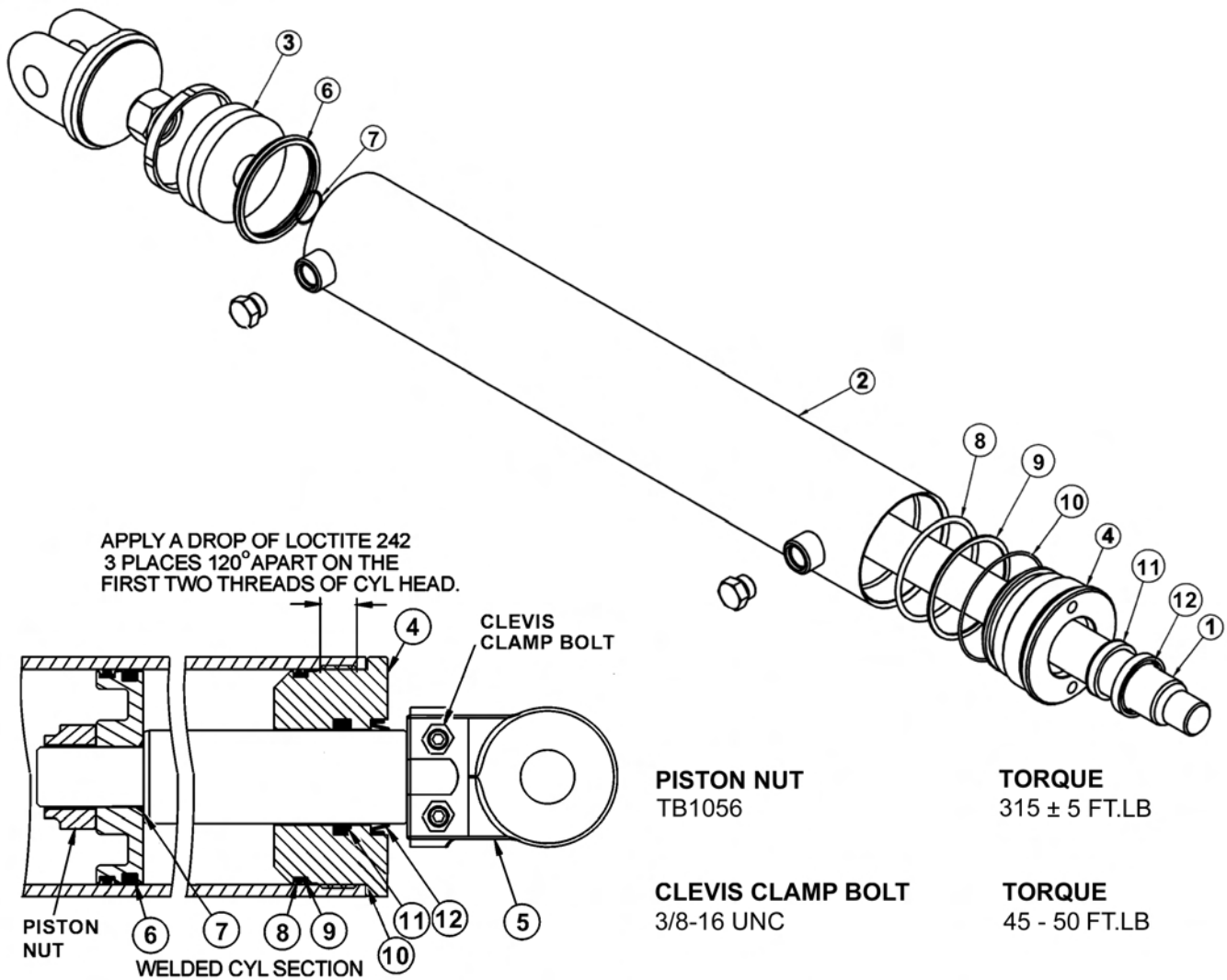

WARNING - MECHANICAL FASTENERS MUST BE TORQUED TO RECOMMENDED SPECIFICATIONS DURING REPAIR TO PREVENT PERSONAL INJURY OR EQUIPMENT DAMAGE.

ITEM	PART NO.	QTY.	DESCRIPTION
-----	06501024	-	HYDRAULIC CYLINDER COMPLETE
1	06501565	1	ROD
2	06501566	1	TUBE WELDMENT
3	06501567	1	PISTON
4	06501568	1	CYLINDER HEAD
5	TB3033	-	CLEVIS
-----	06501569	-	SEAL REPAIR KIT (ITEMS 6 THROUGH 12)

4IN X 20IN WELDED CYLINDER BREAKDOWN

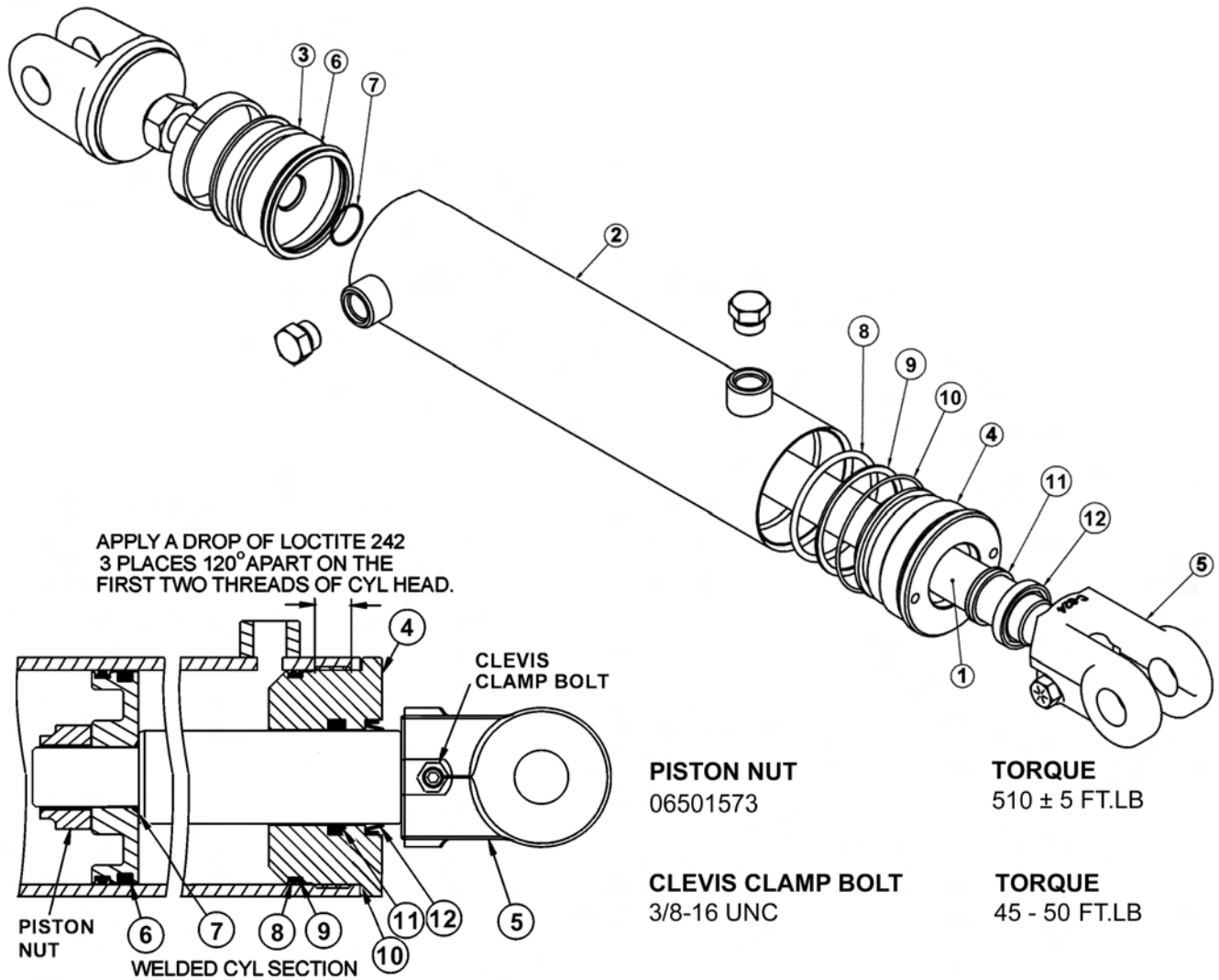

WARNING - MECHANICAL FASTENERS MUST BE TORQUED TO RECOMMENDED SPECIFICATIONS DURING REPAIR TO PREVENT PERSONAL INJURY OR EQUIPMENT DAMAGE.

ITEM	PART NO.	QTY.	DESCRIPTION
-----	06501022	-	HYDRAULIC CYLINDER COMPLETE
1	06501556	1	ROD
2	06501557	1	TUBE WELDMENT
3	06501558	1	PISTON
4	06501559	1	CYLINDER HEAD
5	6T0172	1	CLEVIS
5A	30172	-	CLEVIS (FOR EXTENDED BOOM)
-----	06501560	-	SEAL REPAIR KIT (ITEMS 6 THROUGH 12)

50IN AND 63IN FLAIL MOTOR BREAKDOWN

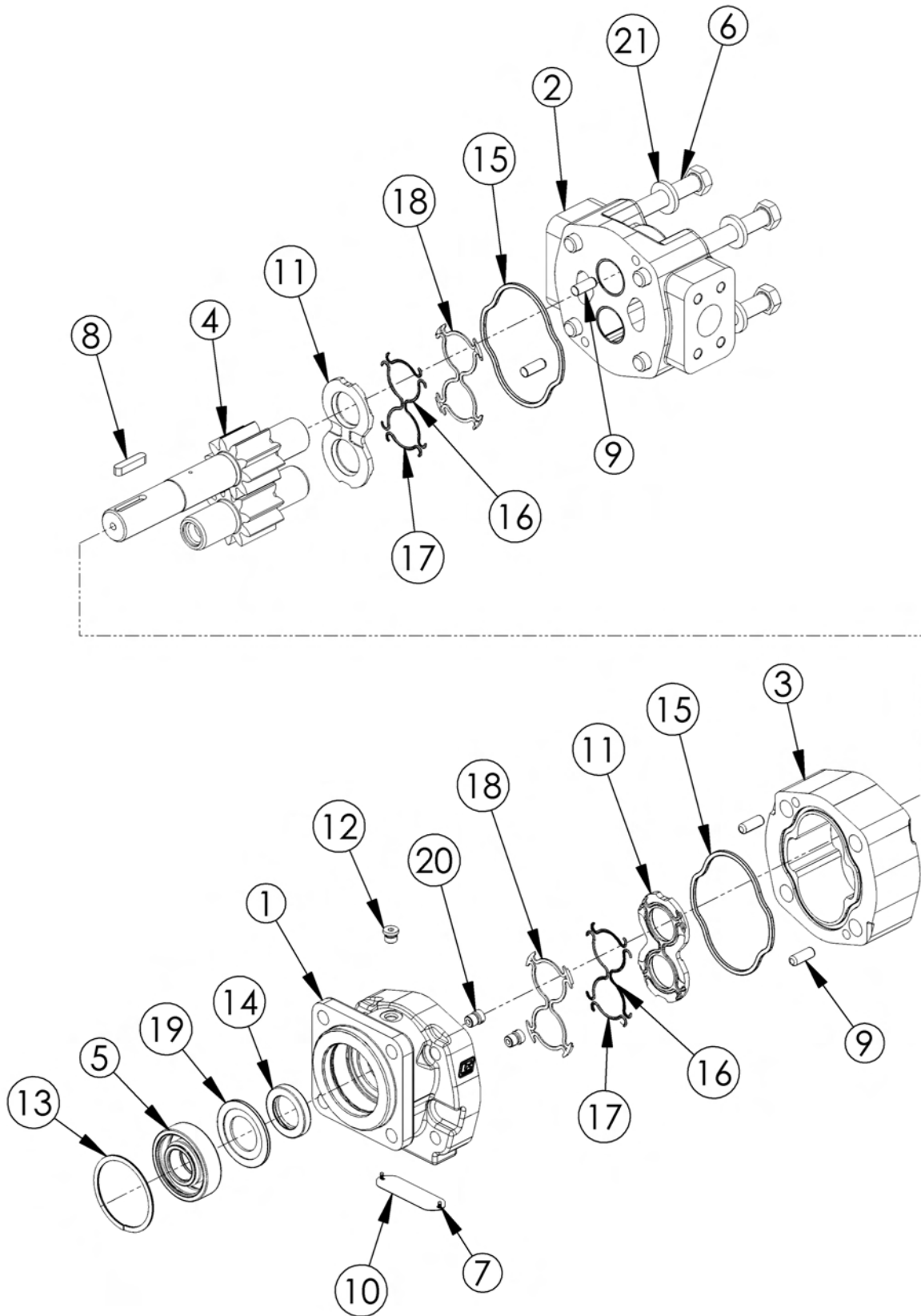

50IN AND 63IN FLAIL MOTOR BREAKDOWN

Continued...

ITEM	PART NO.	QTY.	DESCRIPTION
-----	06504013	-	MOTOR ASSEMBLY 350 - TBF50, TBF63
1	06504039	1	SHAFT END COVER
2	06504040	1	PORT END COVER
3	06504041	1	GEAR HOUSING
4	06504042	1	MATCHED GEAR SET
5	TF4402	1	BALL BEARING
6	06504043	4	CAP SCREW
7	06504044	2	SET SCREW
8	06504028	1	KEY
9	06504045	4	DOWEL PIN
10	-----	1	NAMEPLATE
11	763759	2	THRUSTPLATE
12	02961940	1	HEX PLUG
13	TF4401	1	SNAP RING
14	06504049	1	LIP SEAL
15	TF4410	2	GASKET SEAL
16	06504046	4	SIDE SEAL
17	06504047	4	END SEAL
18	TF4407	2	BACK-UP SEAL
19	06504048	1	SEAL RETAINER
20	6T5809	2	CHECK ASSEMBLY
21	02961917	4	WASHER
-----	06504023	-	SEAL KIT (INCLUDES 14, 15, 16, 17, AND 18)

50IN AND 60IN ROTARY MOTOR BREAKDOWN

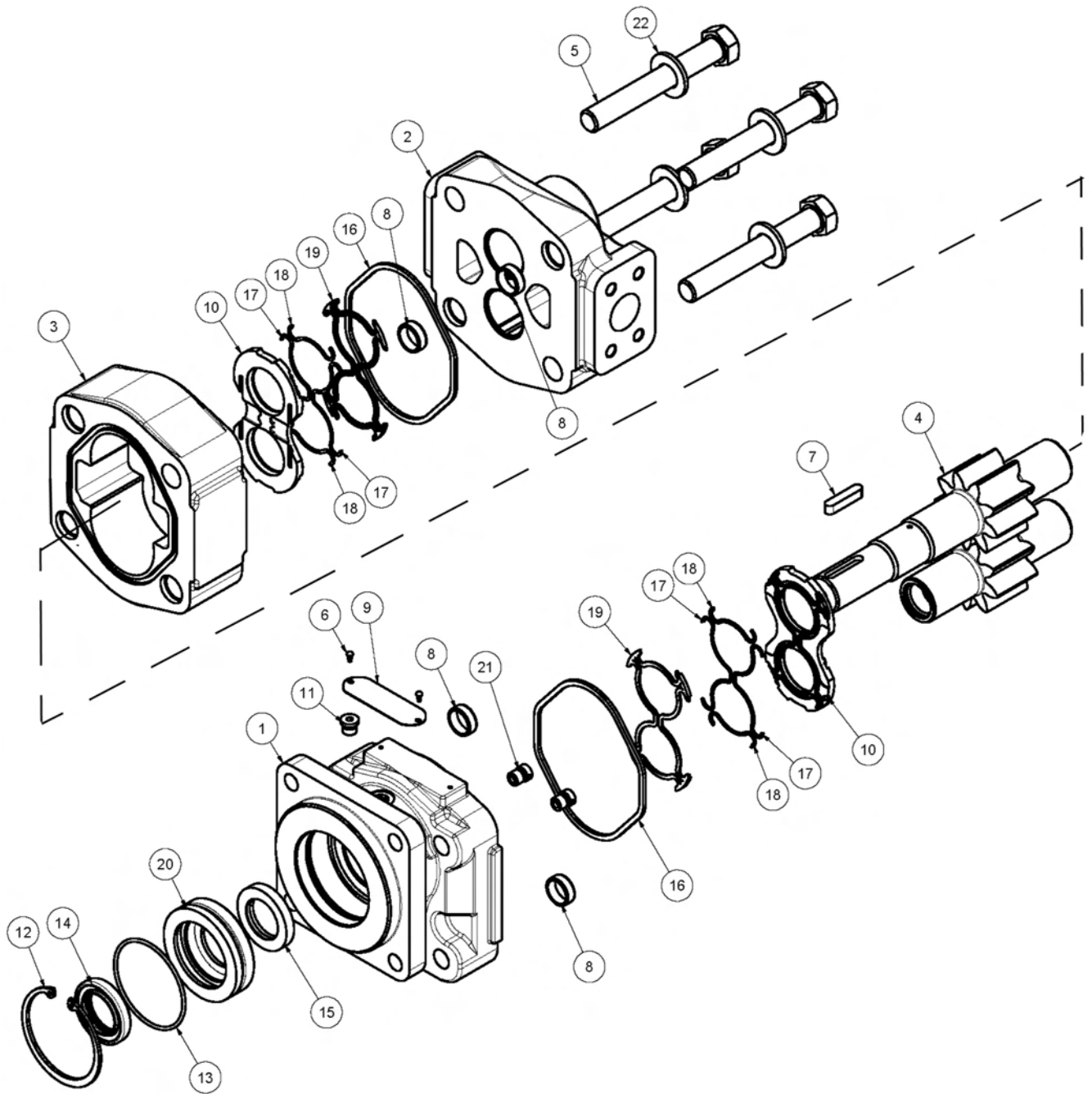

COMMON TRUCKAT/RAILKUT

50IN AND 60IN ROTARY MOTOR BREAKDOWN

Continued...

ITEM	PART NO.	QTY.	DESCRIPTION
	06504011	-	MOTOR ASSEMBLY,TRB60
	06504012	-	MOTOR ASSEMBLY,TRB50
1	22790	1	HOUSING, SEC
2	06504088	1	HOUSING, PEC
3	06504062	1	HOUSING, GEAR,TRB60
-----	06504089	-	HOUSING, GEAR,TRB50
4	06504090	1	SET, GEAR SHAFT
5	06504104	4	CAP SCREW,TRB60
-----	06504091	-	CAP SCREW,TRB50
6	06504078	2	SCREW, DRIVE
7	06504092	1	KEY
8	06504093	4	PIN, DOWEL
9	06504094	1	NAME PLATE
10	06504095	2	THRPL
11	2961940	1	PLUG, ODT
12	2962200	1	RING, SNAP
13	06504096	1	O RING
14	6T5101	1	SEAL, LIP
15	06504097	1	SEAL, LIP
16	22797	2	SEAL, SQ-R
17	06504098	4	SEAL, SIDE CHAN
18	06504099	4	SEAL, END CHAN
19	06504100	2	SEAL, BK-UP
20	06504101	1	RTNR, SEAL
21	6T5809	2	CHECK ASS'Y
22	06504102	4	WASHER
-----	06504103	-	SEAL KIT

COMMON TRUCKAT/RAILKUT

RESERVOIR TANK FILTER ASSEMBLY

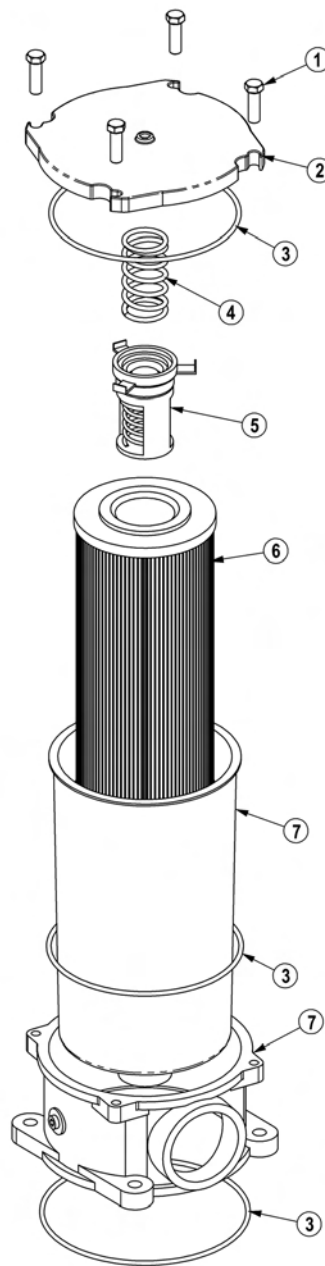

ITEM	PART NO.	QTY.	DESCRIPTION
-----	06505044	-	FILTER ASSY SAE 10 MICRON
1	28583	4	CAPSCREW,8MM X 25MM(1.25 PITCH)
2	06505045	1	COVER
3	06505046	1	SEAL KIT
4	06505047	1	SPRING
5	06505048	1	BYPASS
6	35259	1	FILTER,10 MIC,RETURN LINE
7	06505049	1	CAN/BODY

COMMON TRUCKAT/RAILKUT

BRAKE VALVE ASSEMBLY

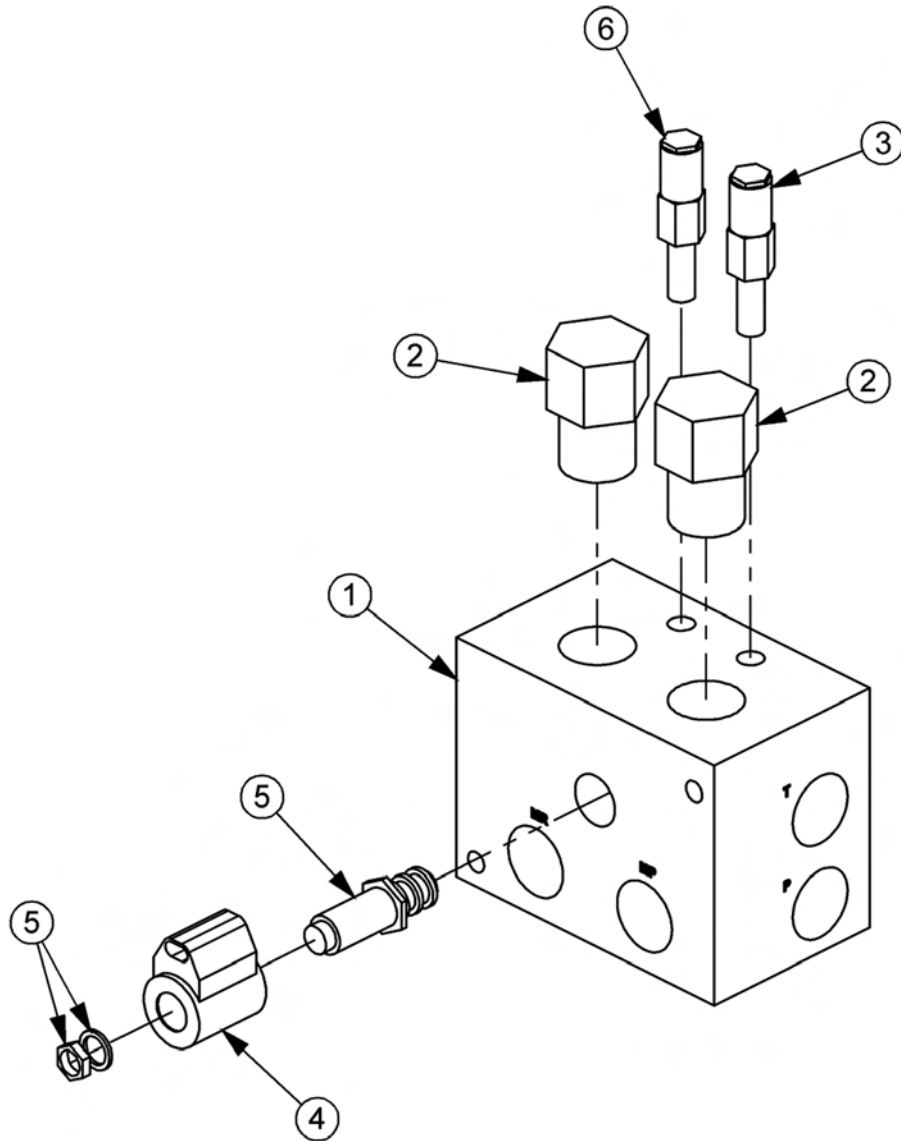

ITEM	PART NO.	QTY.	DESCRIPTION
---	06510083	1	BRAKE VALVE, ASSY
1	34092	1	BRAKE VALVE, BLANK
2	34094	2	LOGIC ELEMENT
3	34095	1	RELIEF VALVE, 3000 PSI
4	06510095	1	METRI PAK COIL
5	34093	1	CARTRIDGE, 2 POSITION, 3 WAY (WITH NUT & WASHER)
6	34091	1	RELIEF VALVE, 2600 PSI
---	34096	2	RELIEF SEAL KIT
----	34097	1	SOLENOID SEAL KIT
---	34098	2	ELEMENT SEAL KIT

COMMON TRUCKAT/RAILKUT

BRAKE VALVE HYDRAULIC SCHEMATIC

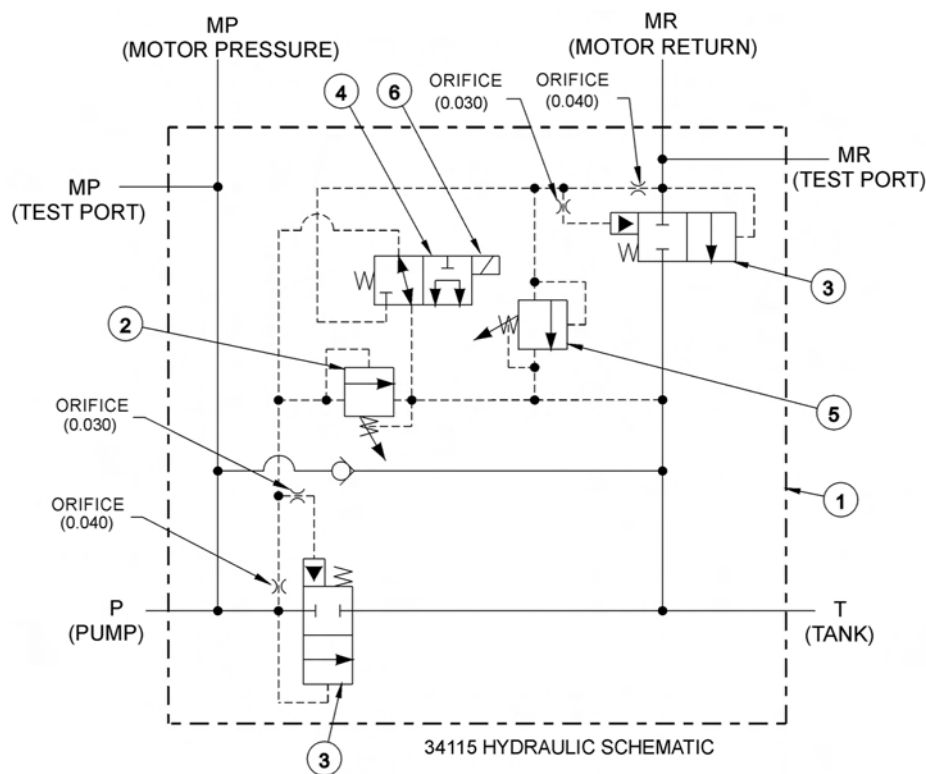

BRAKE VALVE TROUBLESHOOTING

FAILURE MODE:

- MOWER WILL NOT START - system pressure is low (engine not lugging).
- MOWER WILL NOT START - system pressure is high (engine lugging). "MR" port will be high pressure.
- MOWER WILL NOT ROTATE AT FULL SPEED - limited power.
- MOWER BLADE WILL NOT STOP - blade will not stop in proper time.

CHECK STEPS

- 1 thru 6
- 7
- 3 thru 5
- 7 thru 9

CORRECTIVE STEPS:

1. Check for voltage at solenoid (item 6), voltage must be between 10.2 volts and 13.8 volts.
2. Remove, inspect solenoid and cartridge (items 4, 6) for wear or contamination.
3. Remove, inspect logic elements near "P" port (item 3) for wear or contamination.
4. Remove, inspect 3000 psi relief valve (item 2) for wear or contamination.
5. Remove and inspect orifices near "P" port for contamination.
6. Remove "P" port hose and fitting, visually inspect for contamination, check ball for movement.
7. Remove and inspect orifices near "MR" port for contamination.
8. Remove, inspect 2600 psi relief valve (item 5) for wear or contamination.
9. Remove, inspect logic element near "MR" port (item 3) for wear or contamination.

CLEAN CUTTER HEAD

**CLEAN CUTTER
SECTION**

CLEAN CUTTER ASSEMBLY

CAUTION!



Failure to follow the following warnings and instructions may result in serious injury or damage to the equipment or property!

CAUTION!



WARNING: The blade alone weighs approximately 145 lbs. Be sure its weight can be supported before attempting to replace. The use of a lift mechanism will ease replacement.

CLEAN CUTTER BLADE MOUNTING

The CLEAN CUTTER blade was designed for installation onto a standard TRB50 spindle. It is equipped with replaceable carbide tipped teeth. Carbide is very hard, it will chip or break on impact. Handle the saw blade with care. **DO NOT** roll saw on any hard surface or allow it to strike a hard object. Set it down on a piece of belting or wood to avoid damaging carbide tips. Install two temporary(2) threaded studs into (2) opposite holes in the spindle. Align the bolt holes in adapter (part number 33875) with the studs and slide adapter over studs, be sure to index adapter so as the protruding 2 7/8" diameter pilot on the adapter faces outward away from spindle. Then slide the saw blade (part number 33874) over the studs and onto the 2 7/8" diameter pilot of the adapter. **NOTE:** Orient blade for clockwise rotation (blade rotates clockwise when looking down on top of mower deck). Then slide the collar (part number 33876) over the studs with the chamfered edge of collar to the outside, be sure the counterbore bolt holes face outward. Apply Loctite "271" to the threads of the 5/8-18 x 3" UNF Grade 8 bolts (part number 33877), and install lock washers (part number 21992) onto the bolts, then install bolts through collar, blade, and adapter into the spindle. Remove the threaded studs, and replace with bolts and lockwashers. Torque bolts in an alternating pattern to 184 Ft-lbs.

DANGER!



Never work under the Implement, the framework, or any lifted component unless the Implement is securely supported or blocked up to prevent sudden or inadvertent falling which could cause serious injury or even death.



CLEAN CUTTER OPERATION

DANGER!



Never operate the Tractor or Implement until you have read and completely understand this Manual, the Tractor Operator's Manual, and each of the Safety Messages found in the Manual or on the Tractor and Implement. Learn how to stop the tractor engine suddenly in an emergency. Never allow inexperienced or untrained personnel to operate the Tractor and Implement without supervision. Make sure the operator has fully read and understood the manuals prior to operation.



OPERATING INSTRUCTIONS

Inspect clean cutter saw before each use. Re-torque spindle bolts to 204 Ft-lbs. Inspect blade around collar and near the teeth for bends and cracks. Check for loose, broken, chipped, dull or missing teeth. Tighten all loose teeth by hammering and or replacing rivets. If teeth are broken, chipped, or missing or if blade is cracked or becomes bent remove blade and have it repaired at an approved service center. Call Tiger Service Department for replacement parts and service.

The TRB50 Clean Cutter is intended for clean cutting trees and brush up to six (6) inches in diameter maximum. Turn mower "ON" while tractor is running at idle RPM. Then increase tractor speed to 1,950 RPM maximum. Note, this tractor engine speed produces a mower speed of 1,500 RPM. **DO NOT operate the clean cutter mower at speeds in excess of 1,500 RPM.** If saw blade wobbles in excess of two (2) inches while tractor is idling, **STOP**, remove the blade and have it repaired in an approved service center. Call Tiger Service Department for replacement parts and service.

Allow saw to accelerate to maximum speed before moving into foliage. Advance mower head smoothly in foliage. Allow saw to cut through material, do not force or over feed. If saw slows excessively, move the head out of the foliage, and allow the saw to achieve maximum speed. **DO NOT** move up or down or roll mower head while cutting through heavy foliage. **DO NOT** use clean cutter mower on the ground. The saw blade is equipped with carbide tips, which are very hard. Striking rocks, steel, concrete, or other similar debris will break these tips.

Badly worn teeth increase stress to the saw blade and require more horsepower to cut than sharp teeth. Set-up a scheduled maintenance program for the saw before the teeth are dull. The saw will last longer, product a better cut, cut large diameter foliage without binding, and will cost less to operate.

Check adapter and collar every time saw is changed, maintain the .004 inch taper on face (surface against the saw blade) of these two (2) items. Always clean adapter and collar before mounting the blade. If adapter or collars are worn or damaged, they must be replaced.

Familiarize yourself with the machines operation and correct operating safety precautions.

CLEAN CUTTER OPERATION - CONTINUED

WARNING!



Excessive wobble will generate heat in the blade, rapidly accelerating the loss of tension. The overheated blade will then rub against the foliage as it is cutting, again increasing the heat in the blade and intensifying the wobble. The blade may then weaken, crack and eventually fail. **NEVER RUN A BLADE THAT IS CRACKED OR BENT.**

DANGER!



Always keep a careful lookout and use extreme care when working around overhead obstructions. Never allow the Mower head or boom within 10 feet of any power line. When working close to overhead power lines consult your electric company for a safe code of operation.



WARNING!



Do not put hands or feet under mower decks. Blade Contact can result serious injury or even death. Stay away until all motion has stopped and the decks are securely blocked up.



DANGER!



Never operate the Tractor and Mower Unit without an OPS (Operators Protective Structure) or Cab to prevent injury from objects thrown from ground or from overhead trimming. Stop mowing if workers or passersby are within 100 yards.



WARNING!



CAUTION: Never leave the key in the ignition switch. Also personal injury or death can occur from sudden dropping or inadvertent operation of the controls. Make certain the area is clear before lowering or raising the deck.

MAINTENANCE INSTRUCTIONS

Inspect clean cutter saw before each use. Re-torque spindle bolts in an alternating pattern to 204 ft-lbs. Check for loose, broken, chipped, dull or missing teeth. Tighten all loose tooth assemblies by hammer and or replacing rivets. If teeth tips are broken, chipped, or missing, replace tip or replace entire tooth assembly. **NEVER RUN SAW BLADE WITH MISSING TOOTH ASSEMBLY.** If saw blade is cracked, becomes bent or wobbles in excess of two (2) inches while the tractor is idling, **STOP**, remove blade and have it repaired at an approved service center. Call Tiger Service Department for replacement parts and service.

These saw blades are pre-tensioned after the tooth assemblies are riveted in place. This pre-tensioning ensures that the blade runs true and remains true under normal cutting load. Removal of more than one or two complete tooth assemblies at a time may effect the tensioning of the blade. Before cutting always check for wobble while machine is running at idle. If blade wobbles in excess of two (2) inches, **STOP**, remove blade and have it repaired at an approved service center. The teeth tips can be replaced without removing the tooth bodies from the saw blade (see TIP REPLACEMENT PROCEDURE). This method is preferred over the entire removal of tooth assemblies.

Check adapter and collar every time saw is changed, maintain the .004 to .006 inch taper (see figure below) on inside face (surface against saw blade) of these two (2) items. Always clean inside face of adapter and collar before mounting the blade. If adapter or collars are worn, chipped, or damaged, they must be replaced.

Any saw blade (regardless of condition) that has seen regular use should be serviced at least once a year at an approved service center.

Spare saw blades should be stored in a dry environment and transported only on the wooden crates that are supplied with the saw blade.

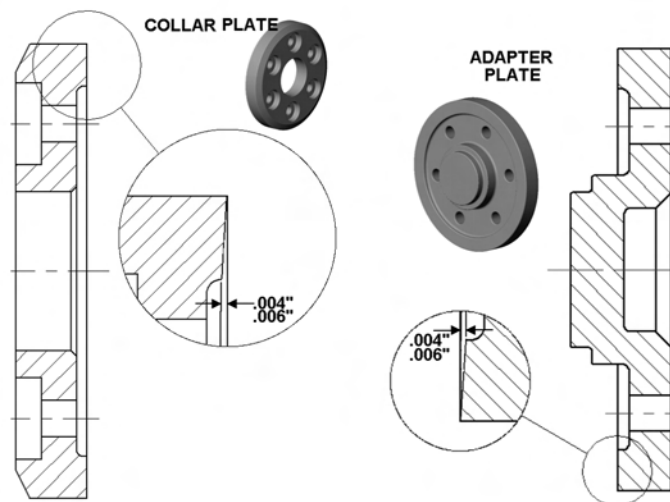

CLEAN CUTTER BLADE AND TEETH PARTS

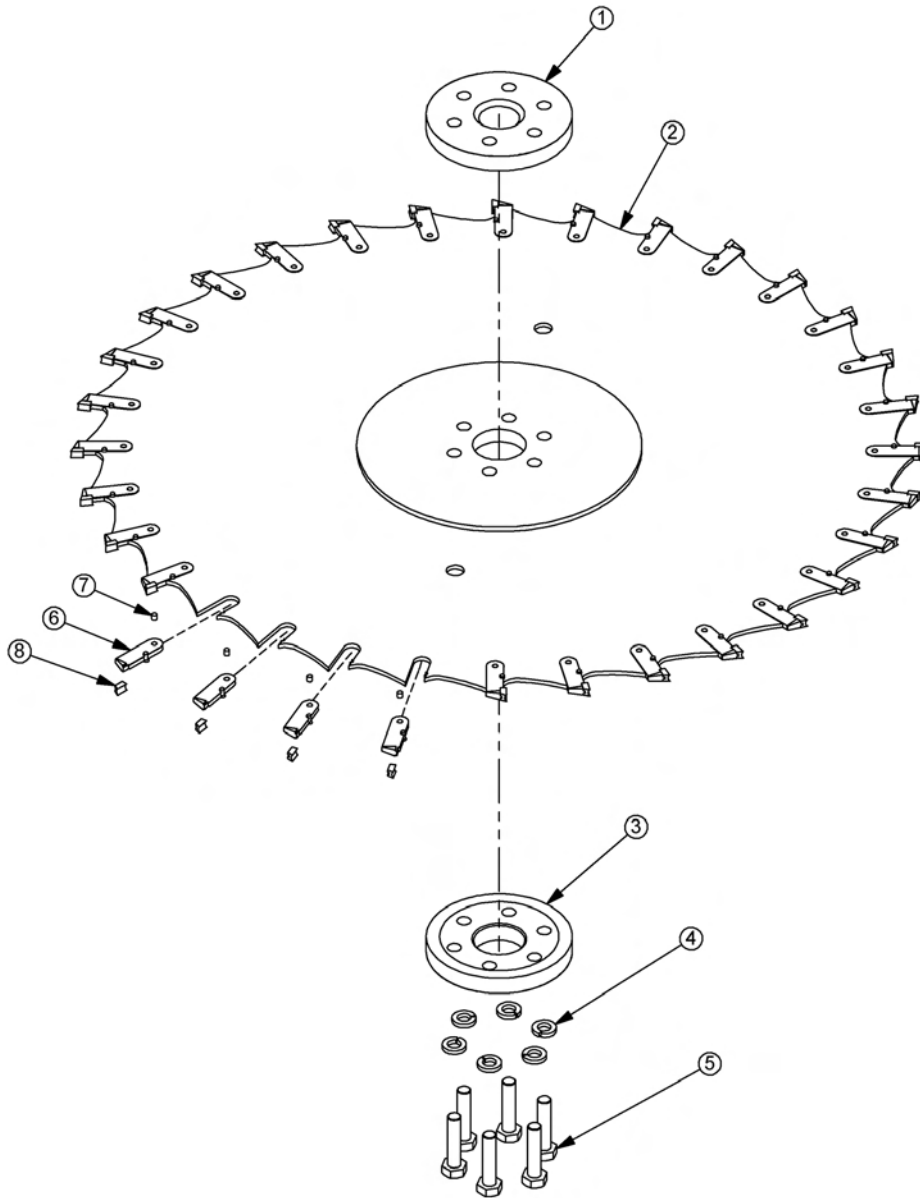

ITEM	PART NO.	QTY.	DESCRIPTION
1	06420024	1	ADAPTER,SAW,TRB50,RNFRCD
2	06520224	1	BLADE, 48" SAW WITH TEETH
3	06420037	1	COLLAR,SAW,TRB50,RNFRCD
4	33764	6	FLATWASHER,5/8,GR 8,SAE
5	06530209	6	CAPSCREW,5/8 X 3 3/4 NF, GR 8
6	06520225	30	TOOTH WITH RIVET, SAW BLADE
7	34703	30	TOOTH RIVET, SAW BLADE
-----	34704	-	RIVET REMOVER TOOL (NOT SHOWN)
8	34702	30	TOOTH TIP, SAW, CARBIDE
-----	34705	-	SHARPENING TOOL (NOT SHOWN)

COMMON TRUCKAT/RAILKUT

CARBIDE TIP REPLACEMENT

1. Heat face of tip to dull orange, remove tip, then brush tooth body clean of all debris (carbon).
2. Apply acetone to socket rail on tooth body and allow it to evaporate. Dab on soldering paste (black flux) to socket rail of tooth body and slide pre-tinned tip into place.
3. Then heat tip sides and base of socket rail to ensure silver solder flows completely around base of tip. Grasp tip with tweezers and gently twist tip back and forth to ensure complete bonding of silver solder.
4. Discontinue heat, and allow to cool. Then check braze by gently tapping tip with rubber mallet.

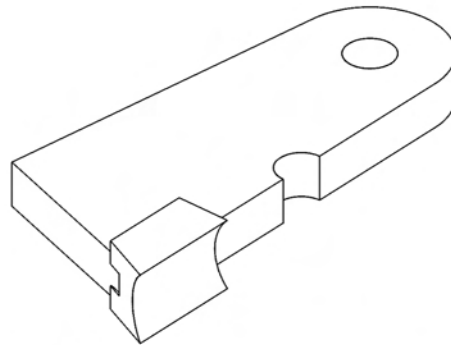

VIEW OF ASSEMBLED TOOTH

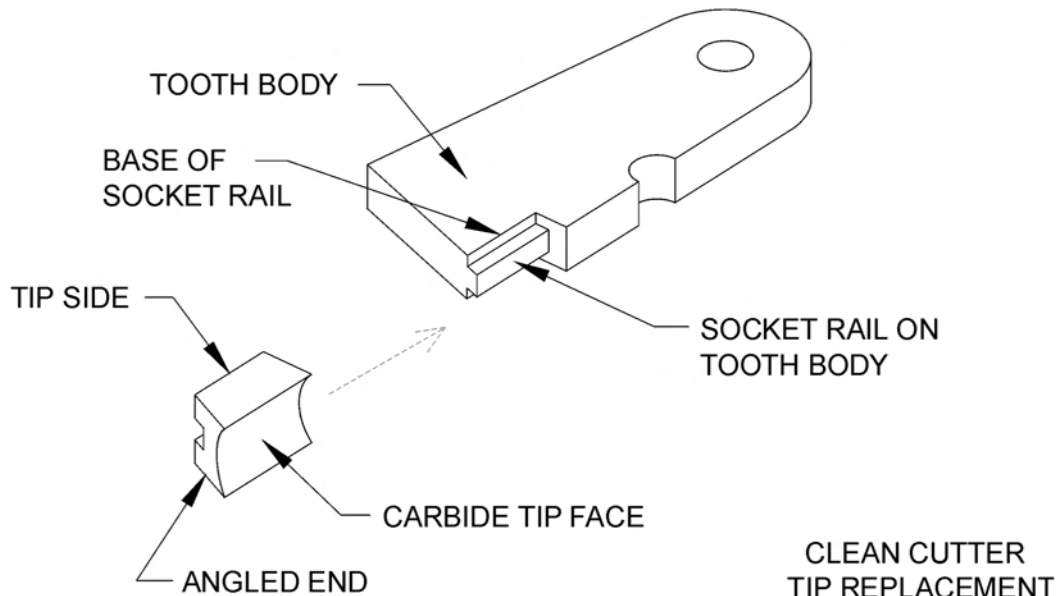

NOTES

**FIRE SUPPRESSION SYSTEM
SECTION**

FIRE SUPPRESSION SYSTEM PARTS

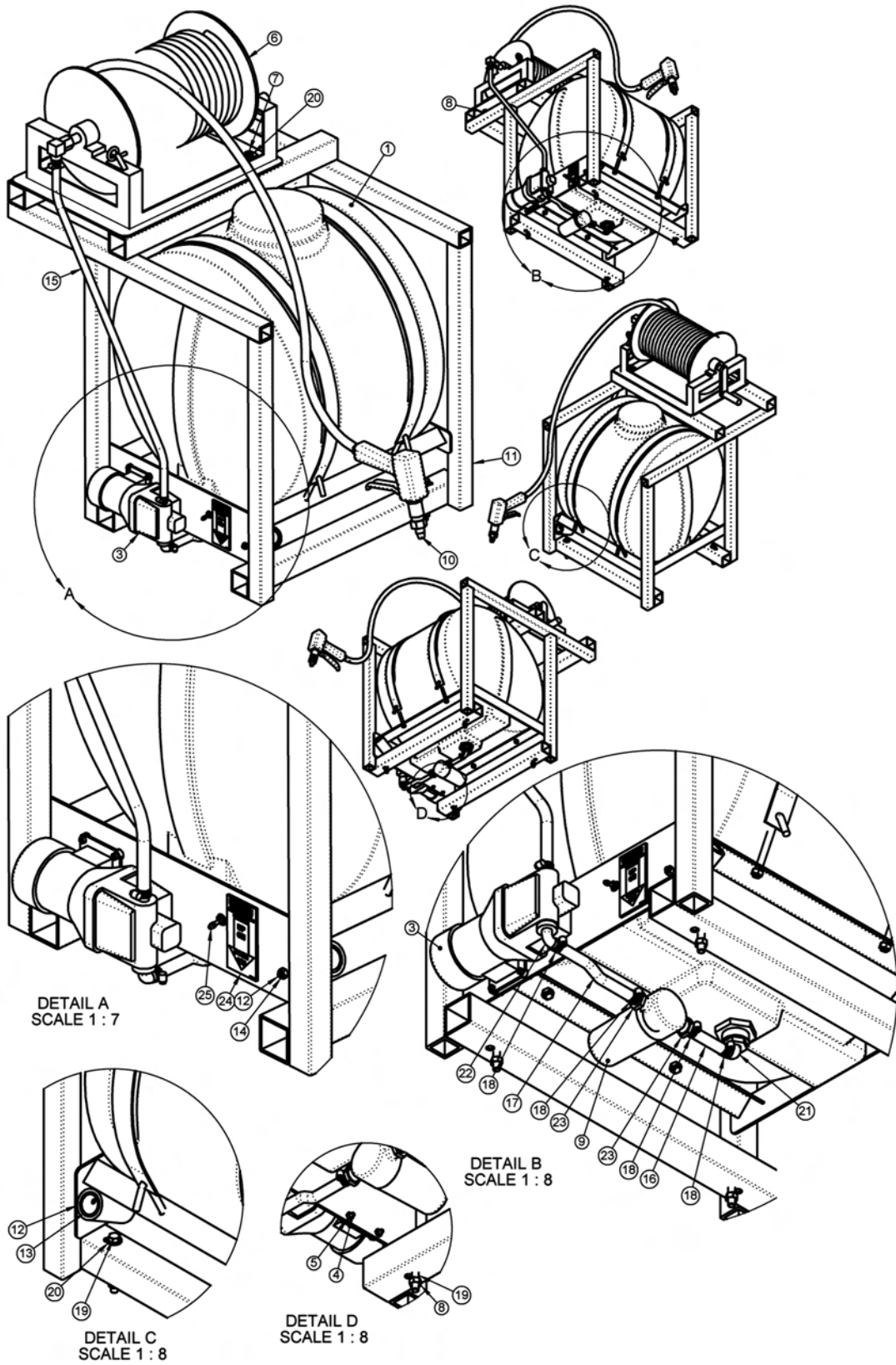

FIRE SUPPRESSION SYSTEM PARTS

Continued...

ITEM	PART NO.	QTY.	DESCRIPTION
1	06520357	1	TANK,FIRE SUPRESS SYS,RAILKUT
2	06520358	1	MNT,TANK,FIRE KIT,RAILKUT
3	06520359	1	PUMP,FIRE SUPRESS SYS,RAILKUT
4	6T2181	4	CAPSCREW,SKT HD,10/24 X 3/4
5	24890	4	HEX NUT,10-24 NYLOCK
6	06520360	1	HOSE REEL,FIRE KIT,RAILKUT
7	21630	4	CAPSCREW, 3/8 X 1,NC
8	21627	8	NYLOCK NUT,3/8",NC
9	06520361	1	FILTER,FIRE KIT,RAILKUT
-----	06520365	-	FILTER ELEMENT (AVAILABLE)
10	06520366	1	GUN,FIRE KIT,RAILKUT
11	06370120	1	STAND,FIRESYS,RAILKUT
12	06370121	1	HOLSTER,FIRESYS,RAILKUT
13	06430090	1	SLEEVE,GUN,FIRE SYS
14	21525	1	HEX NUT, 1/4" NC
15	06520380 - A	1	HOSE,.88O.D.X.50I.D.,BULK
16	06520380 - B	1	HOSE,.88O.D.X.50I.D.,BULK
17	06520380 - C	1	HOSE,.88O.D.X.50I.D.,BULK
18	35091	6	CLAMP, HOSE #10
19	21640	4	CAPSCREW,3/8" X 3-1/2" NC
20	22016	8	FLATWASHER,3/8"
21	06520367	1	ELBOW,3/4COUPLERX1/2BARB,NYLON
22	06520368	1	ELBOW,3/4COUPLERX1/2BARB,NYLON
23	06503108	2	ADAPTER,BARB,1/2X1/2MP
24	6T3222	1	DECAL,CONTROL,ON-OFF SWITCH
25	PT3905A	1	SWITCH,MOWER
-----	06520364	-	FILTER SEAL (AVAILABLE)

COMMON TRUCKAT/RAILKUT

FIRE SUPPRESSION SYSTEM ELECTRICAL SCHEMATIC

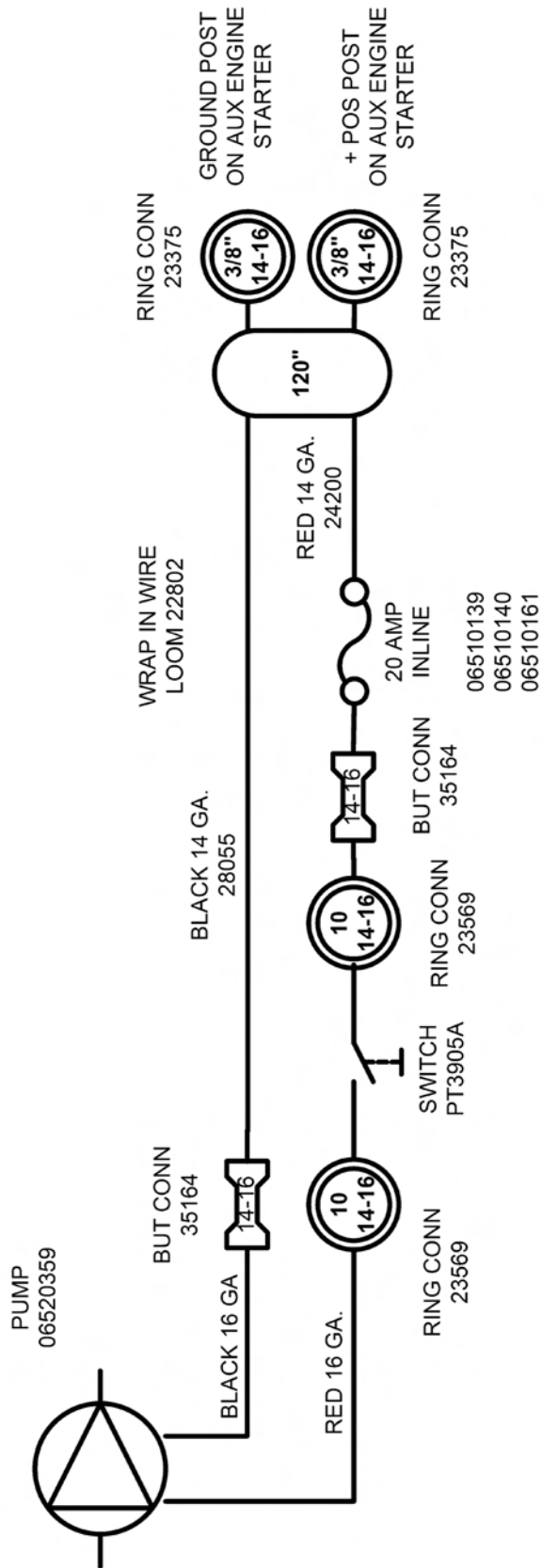

WETCUT

**WETCUT
SECTION**

WETCUT 50 GALLON TANK MOUNT

INSTALL ITEM 2 INTO ITEM 1 FIRST

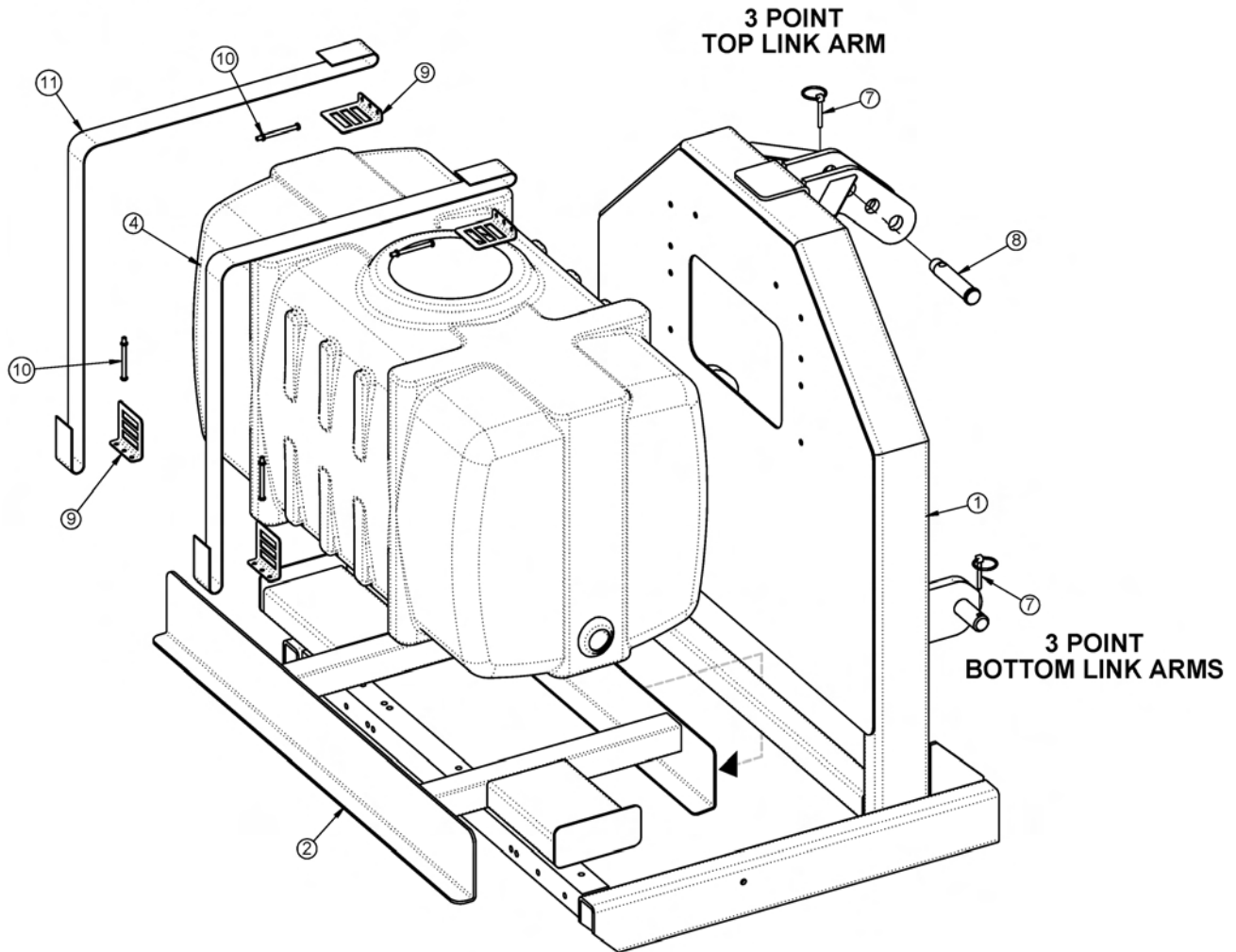

ITEM	PART NO.	QTY.	DESCRIPTION
1	06370128	1	MNT,3PNT,UNI
2	06370136	1	MNT,TANK,50GAL,WETCUT
4	06520342	1	TANK,50GA.,WETCUT
7	RD1032	3	PIN,LYNCH 1/4" X 2"
8	TB1036	1	PIN,SEC BOOM SWIV 1X4-11/16"
9	06520343	4	ANCHOR,STRAP,WETCUT
10	06520344	4	BOLT,STRAP,TANK,WETCUT
11	06520345	2	STRAP,TANK,WETCUT

COMMON TRUCKAT/RAILKUT

WETCUT 100 OR 150 GALLON TANK MOUNT

INSTALL ITEM 2 INTO ITEM 1 FIRST

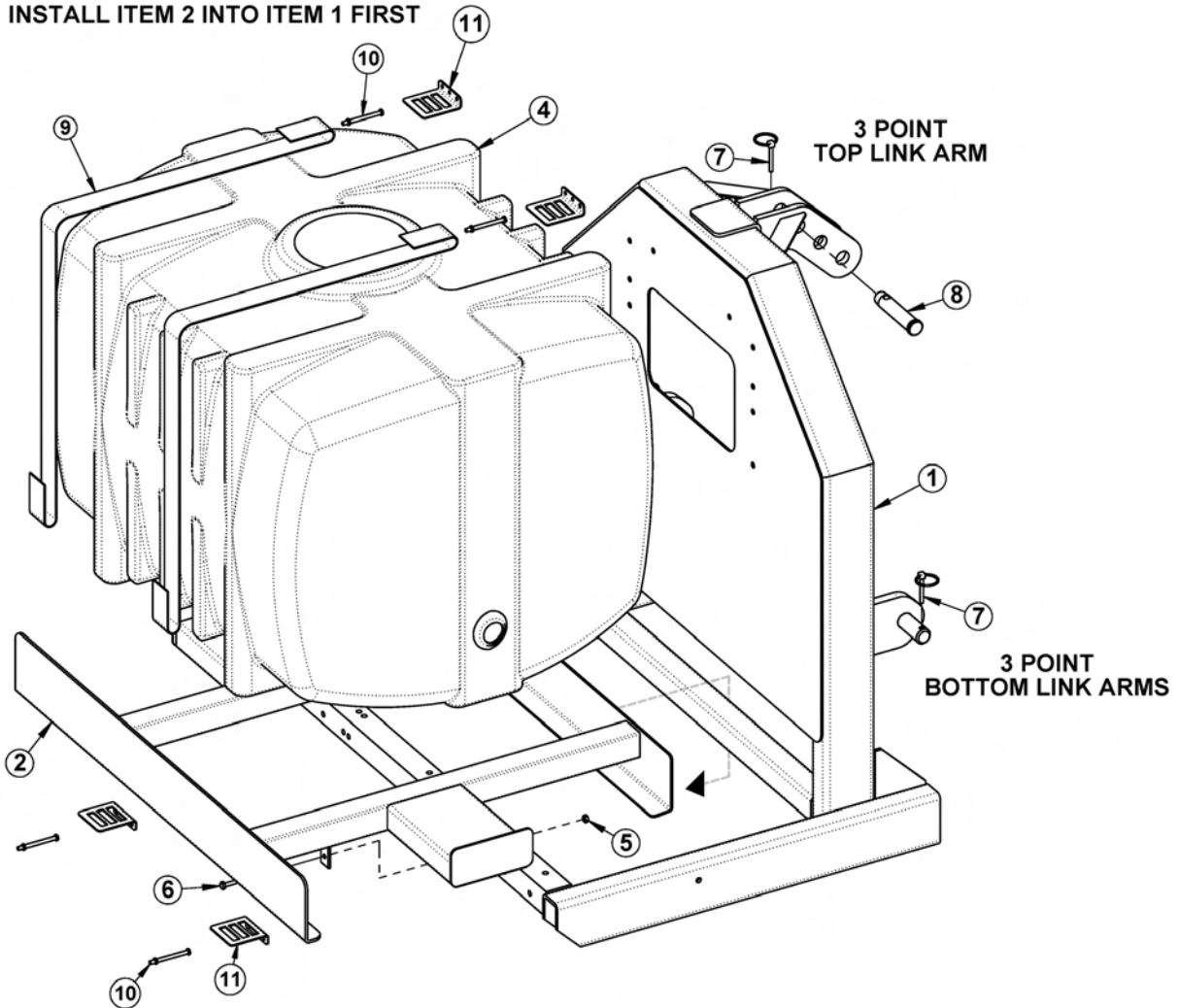

ITEM	PART NO.	QTY.	DESCRIPTION
1	06370128	1	MNT,3PNT,UNI
2	06370138	1	MNT,TANK,100GAL,WETCUT
-----	06370139	-	MNT,TANK,150GAL,WETCUT
4	06520372	1	TANK,100GA.,WETCUT
-----	06520373	-	TANK,150GA.,WETCUT
5	21527	2	HEX NUT,NYLOCK,1/4" NC
6	21530	2	CAPSCREW,1/4" X 1" NC
7	RD1032	3	PIN,LYNCH 1/4" X 2"
8	TB1036	1	PIN,SEC BOOM SWIV 1X4-11/16"
9	06520345	2	STRAP,TANK,WETCUT
10	06520344	4	BOLT,STRAP,TANK,WETCUT
11	06520343	4	ANCHOR,STRAP,WETCUT

COMMON TRUCKAT/RAILKUT

WETCUT TANK PLUMBING

1. NOTE ORIENTATION ON ITEM ⑨
2. ITEMS ⑰ ⑱ ⑲ ⑳ CUT FROM SUPPLIED 1/2" HOSE
3. ITEMS ㉑ ㉒ ㉓ CUT FROM SUPPLIED 3/8" HOSE

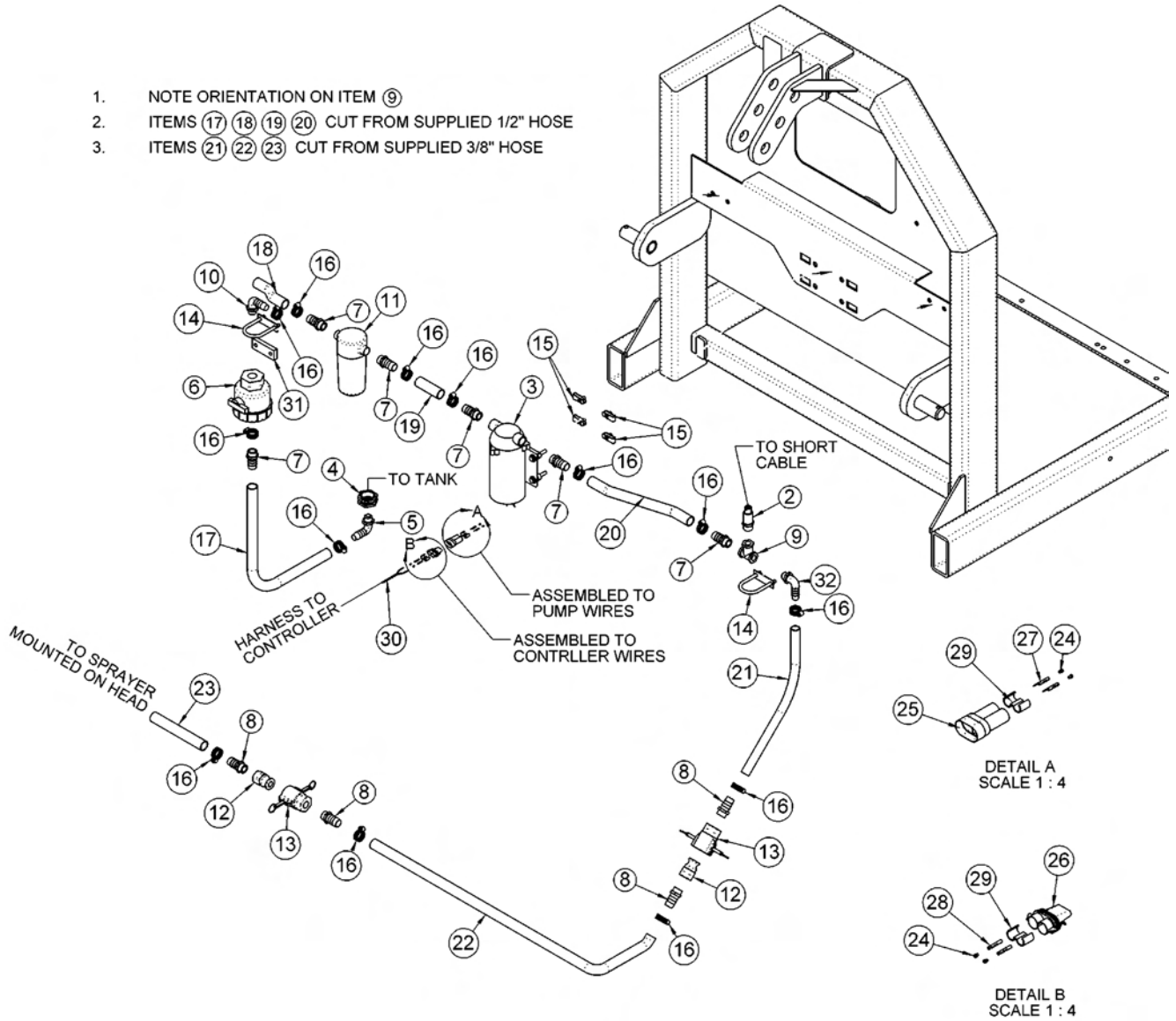

WETCUT TANK PLUMBING

Continued...

ITEM	PART NO.	QTY.	DESCRIPTION
1	06370128	1	MNT,3PNT,UNI
2	06520336	1	CNTRLR,SENSOR,06520333
3	06520341	1	PUMP,WETCUT
4	06520346	1	FITTING,BULKHEAD,WETCUT
5	06520347	1	FITTING,ELBOW,WETCUT
6	06520348	1	VLV,BALL,WETCUT
7	06520349	6	FITTING,BARB,HOSE,WETCUT
8	06503173	4	FITTING,BARB,1/2X3/8,WETCUT
9	06520353	1	FITTING,TEE,WETCUT
10	06520367	1	ELBOW,1/2MPX1/2BARB,POLY
11	06520361	1	FILTER,FIRE KIT,RAILKUT
12	06520400	2	QUIK CPLR,MALE,1/2,WETCUT
13	06520401	2	QUIK CPLR,FEM,1/2,WETCUT
14	27329	2	U-BOLT,1/4" X 1" X 2"
15	35176	4	U-NUT,1/4,3/4 TO CENTER
16	35091	13	CLAMP, HOSE #6
17 - 20	-----	-	1/2" HOSE INCLUDED WITH TANK
21 - 23	06520316	-	3/8" HOSE INCLUDED WITH SPRAYER
24	06510051	4	SEAL,16-18GA,METPAK
25	06510052	1	CONN.,BODY,MALE,METRIPACK 150
26	06510053	1	CONN.,BODY,FEM,METRIPACK 150
27	06510054	2	TERMINAL,MALE,16/18GA.METPAK
28	06510055	2	TERMINAL,FEM,16/18GA.METPAK
29	06510056	2	TPA
30	06520337	1	INCLUDED WITH CONTROLLER
31	06401133	1	SPACER,Ø.31X1.75X.38
32	06503165	1	ELBOW,1/2MPX3/8BARB,POLY

COMMON TRUCKAT/RAILKUT

WETCUT 50IN SPRAYER HEAD ASSEMBLY

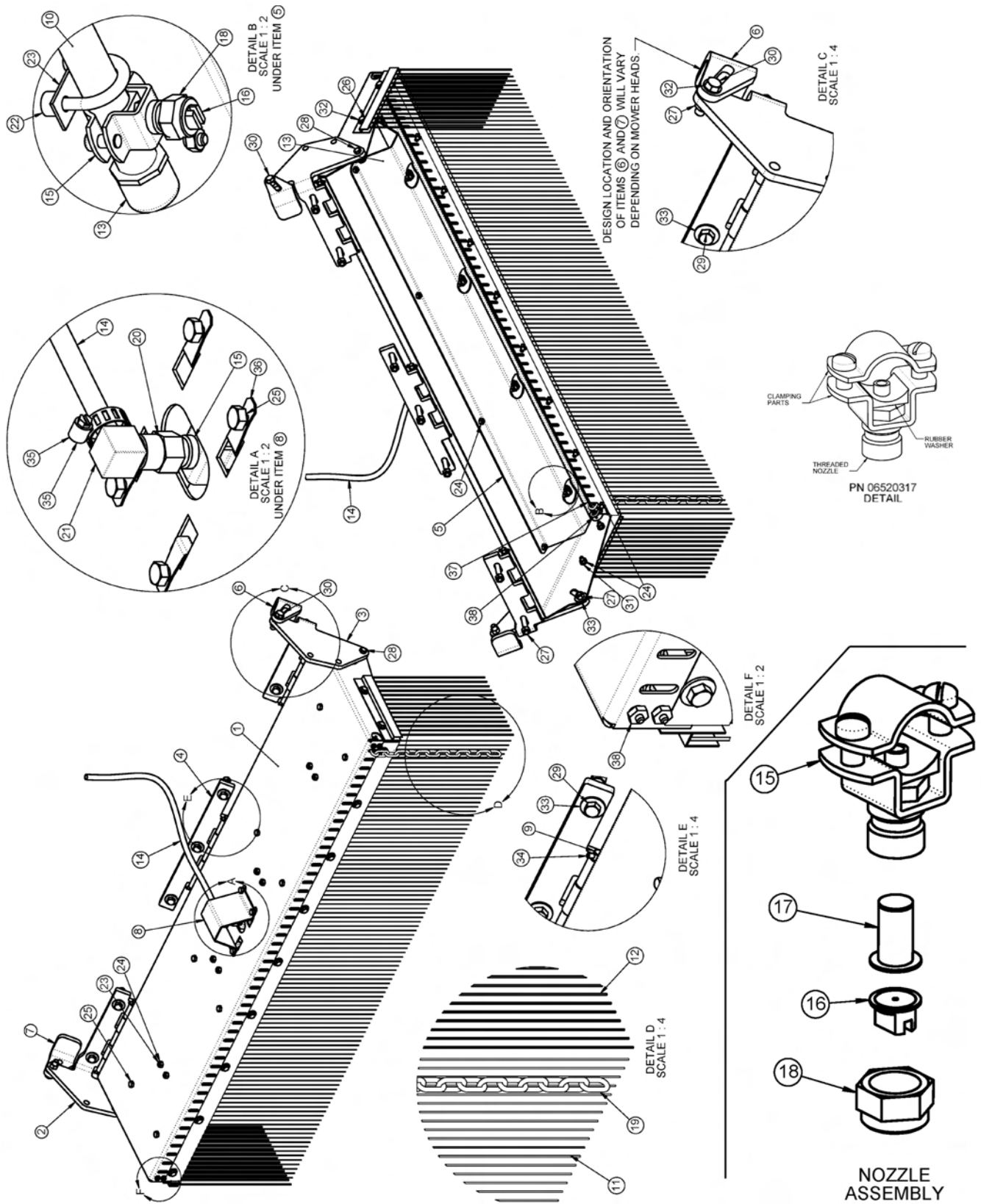

COMMON TRUCKAT/RAILKUT

WETCUT 50IN SPRAYER HEAD ASSEMBLY

Continued...

ITEM	PART NO.	QTY.	DESCRIPTION
1	06370105	1	HOOD,SPRAYER
2	06370106	1	HINGE,LH,SPRAYER
3	06370107	1	HINGE,RH,SPRAYER
4	06370108	1	HINGE,CNTR,SPRAYER
5	06410668	1	GUARD,SPRAYER,WETCUT
6	06410753	1	MNT,RH,WET CUT (FLAIL)
---	06410942	1	MNT,RH,WET CUT (ROTARY)
7	06410754	1	MNT,LH,WET CUT (FLAIL)
---	06410943	1	MNT,LH,WET CUT (ROTARY)
8	06410796	1	GUARD,HOSE,WETCUT
9	06420069	3	PIN,HINGE,WET CUT
10	06497003	1	TUBE,LG,SPRAYER
11	06499012	1	SKIRT,ANTI SPRAY,50
12	06499013	2	SKIRT,ANTI SPRAY,7
13	06520314	2	TUBE,CAP,SPRAYER
14	06520316	15	HOSE,SPRAYER (FEET)
15	06520317	5	NOZZLE,SPRAYER
16	06520319	4	TIP,NOZZLE,SPRAYER
17	06520320	4	FILTER,NOZZLE,SPRAYER
18	06520321	4	NUT,NOZZLE,SPRAYER
19	06520322	49	CHAIN,.18" X 1.31" X 13LINKS
20	06520381	1	ADAPTER,1/4"NPT,WETCUT
21	06520382	1	ELBOW,BARB,3/8" X 1/4"NPT
22	06520383	8	SPACER,.50"O.D. X .252" I.D. X .38",NYLON
23	32550	4	U-BOLT,1/4" X 1" X 1" X 1-3/4"
24	21527	29	HEX NUT,NYLOCK,1/4",NC
25	21528	12	CAPSCREW,1/4" X 1/2",NC
26	21529	13	CAPSCREW,1/4" X 3/4",NC
27	21625	11	HEX NUT,3/8",NC
28	21630	2	CAPSCREW,3/8" X 1",NC
29	21634	7	CAPSCREW,3/8" X 2",NC
30	21632	2	CAPSCREW,3/8" X 1-1/2",NC
31	21986	4	LOCKWASHER,1/4"
32	22014	15	FLATWASHER,1/4"
33	22016	9	FLATWASHER,3/8",GR8
34	34698	6	ROLL PIN, PLAIN, 3/16" X 7/8"
35	35091	1	CLAMP,HOSE #6
36	35176	4	U-NUT,1/4",3/4" TO CENTER
37	06520376	5	CABLE,3/16"
38	06537022	2	U-BOLT,CABLE,3/16"

COMMON TRUCKAT/RAILKUT

WETCUT 60IN SPRAYER HEAD ASSEMBLY

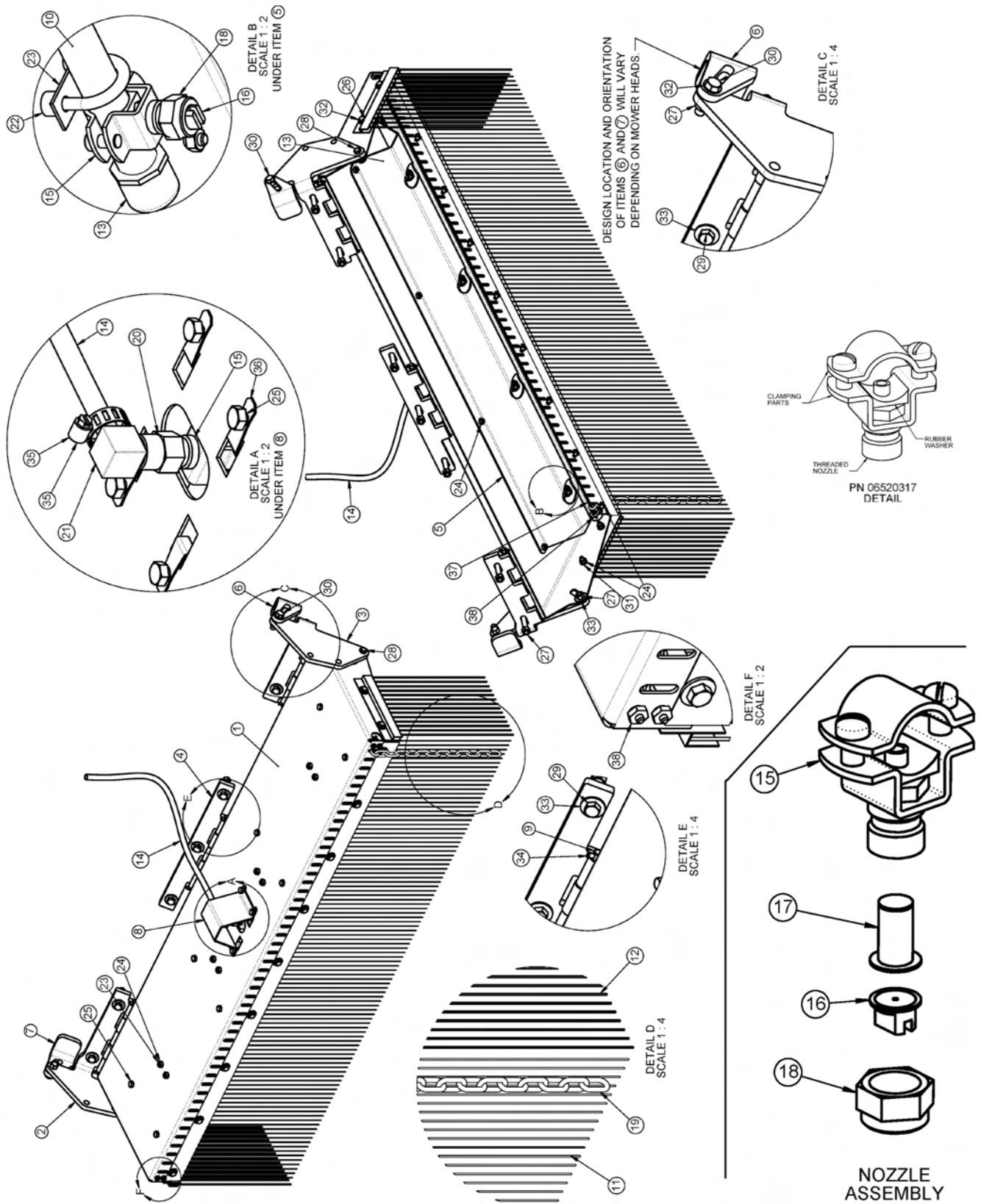

COMMON TRUCKAT/RAILKUT

WETCUT 60IN SPRAYER HEAD ASSEMBLY

Continued...

ITEM	PART NO.	QTY.	DESCRIPTION
1	06370210	1	HOOD,SPRAYER
2	06370106	1	HINGE,LH,SPRAYER
3	06370107	1	HINGE,RH,SPRAYER
4	06370108	1	HINGE,CNTR,SPRAYER
5	06411234	1	GUARD,SPRAYER,WETCUT
6	06410753	1	MNT,RH,WET CUT (FLAIL)
---	06410942	1	MNT,RH,WET CUT (ROTARY)
7	06410754	1	MNT,LH,WET CUT (FLAIL)
---	06410943	1	MNT,LH,WET CUT (ROTARY)
8	06410796	1	GUARD,HOSE,WETCUT
9	06420069	3	PIN,HINGE,WET CUT
10	06497009	1	TUBE,LG,SPRAYER
11	06499018	1	SKIRT,ANTI SPRAY,60
12	06499013	2	SKIRT,ANTI SPRAY,7
13	06520314	2	TUBE,CAP,SPRAYER
14	06520316	15	HOSE,SPRAYER (FEET)
15	06520317	6	NOZZLE,SPRAYER
16	06520319	5	TIP,NOZZLE,SPRAYER
17	06520320	5	FILTER,NOZZLE,SPRAYER
18	06520321	5	NUT,NOZZLE,SPRAYER
19	06520322	61	CHAIN,.18" X 1.31" X 13LINKS
20	06520381	1	ADAPTER,1/4"NPT,WETCUT
21	06520382	1	ELBOW,BARB,3/8" X 1/4"NPT
22	06520383	10	SPACER,.50"O.D. X .252" I.D. X .38",NYLON
23	32550	5	U-BOLT,1/4" X 1" X 1" X 1-3/4"
24	21527	33	HEX NUT,NYLOCK,1/4",NC
25	21528	15	CAPSCREW,1/4" X 1/2",NC
26	21529	13	CAPSCREW,1/4" X 3/4",NC
27	21625	13	HEX NUT,3/8",NC
28	21630	2	CAPSCREW,3/8" X 1",NC
29	21634	7	CAPSCREW,3/8" X 2",NC
30	21632	4	CAPSCREW,3/8" X 1-1/2",NC
31	21986	4	LOCKWASHER,1/4"
32	22014	33	FLATWASHER,1/4"
33	22016	11	FLATWASHER,3/8",GR8
34	34698	6	ROLL PIN, PLAIN, 3/16" X 7/8"
35	35091	1	CLAMP,HOSE #6
36	35176	4	U-NUT,1/4",3/4" TO CENTER
37	06520376	6	CABLE,3/16" (FEET)
38	06537022	2	U-BOLT,CABLE,3/16"

COMMON TRUCKAT/RAILKUT

WETCUT CABLES

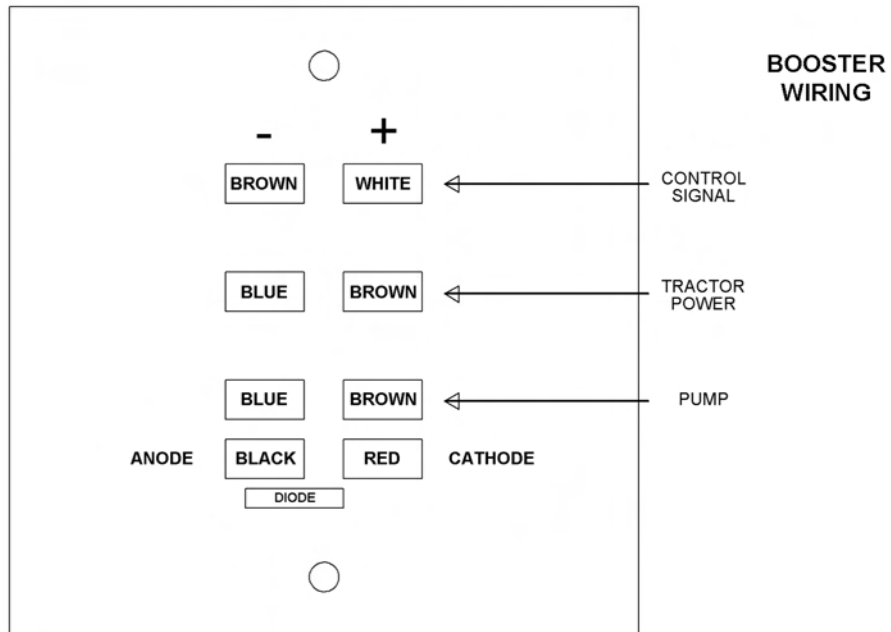
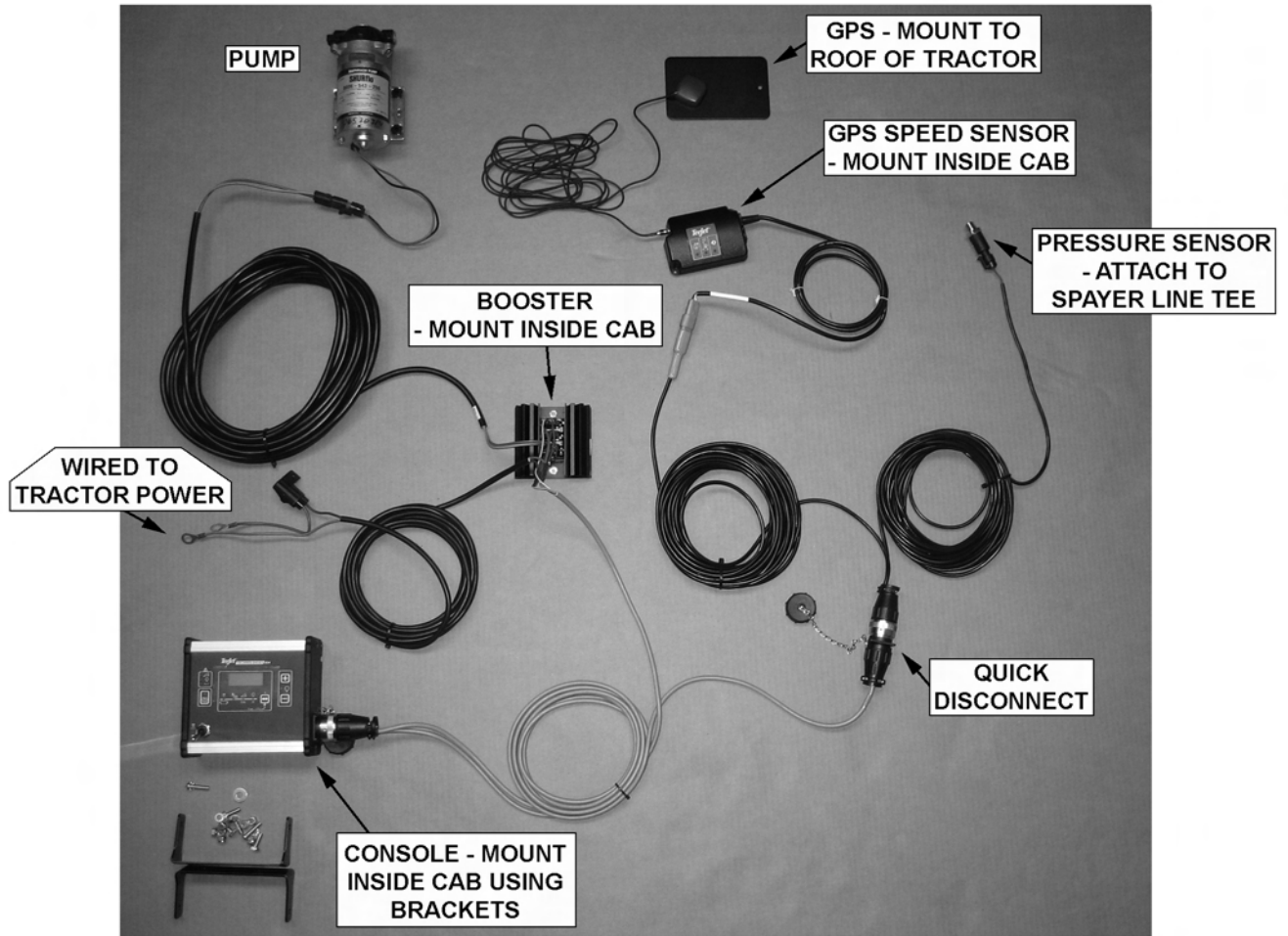

**WARRANTY
SECTION**

WARRANTY INFORMATION

Tiger Corporation, 3301 N. Louise, Sioux Falls, South Dakota, warrants to the original Retail Customer, the new Tiger equipment is free of defects in material and workmanship. Any part of equipment that in Tiger's judgement, show evidence of such defects will be repaired or replaced without charge, provided that the failure of part(s) shall have occurred within twelve (12) months from the date of delivery of said equipment to the Retail Customer. Expendable components such as knives, oil, chain sprockets, skid shoes, knife mounting disks and the like are excluded but not limited to this warranty.

The Retail Customer must pay the transportation cost to and from the Tiger Dealer's service shop for warranty service. Warranty service will be performed by the Tiger Dealer from whom the equipment was purchased, during service shop regularly scheduled days and hours of operation.

All Tiger obligation under this warranty shall be terminated if the equipment is modified or altered in ways not approved in writing by Tiger, if repair parts other than genuine Tiger repair parts have been used, or if the equipment has been subject to misuse, neglect, accident, improper maintenance or improper operation.

Tiger Corporation reserves the right to make improvements in design or changes in specification at any time without incurring any obligation to owners of equipment previously sold.

No agent or person has authority to alter, add to or waive the above warranties which are agreed to be in the only warranties, representations or promises, expressed or implied, as to the quality or performance of the products covered and which do not include any implied warranty of merchantability or fitness. In no event will Tiger be liable for incidental or consequential damages or injuries, including, but not limited to, loss of profits, rental or substitute equipment or other commercial loss.

**THERE ARE NO WARRANTIES WHICH EXTEND
BEYOND THOSE EXPRESSED HEREIN.**

It is the Purchasers obligation to sign the warranty registration form **AFTER** he / she has Read and Understands the Operation and Safety Instructions stated within this manual.

ONE LAST WORD

This manual cannot possibly cover all of the potentially hazardous situations you will encounter. By being familiar with the safety rules, operating and maintenance instructions in this manual you can help prevent accidents. The objective of this manual is to help make you a better operator. Remember, **SAFETY IS YOU!**



1012

Your safety and the safety of those around you depends on **YOU**. Common sense should play a large role in the operation of this machine.

Since we at Tiger Corporation are constantly striving to improve our products, we reserve the right to change specifications or design at any time.

TO THE OWNER / OPERATOR / DEALER



To keep your implement running efficiently and safely, read your manual thoroughly and follow these directions and the Safety Messages in this manual and on the machine. The table of contents clearly identifies each section where you can easily find the information you need.

The Occupational Safety and Health Act (OSHA 1928.51 subpart C) makes the following minimum requirements for tractor operators.

OWNER REQUIREMENTS:

1. Provide a Roll-Over-Protective Structure that meets the requirements of this Standard; and
2. Provide Seatbelts that meet the requirements of this Standard and SAE J3C; and
3. Ensure that each employee uses such Seatbelt while the tractor is moving; and
4. Ensure that each employee tightens the Seatbelt sufficiently to confine the employee to the protected area provided by the ROPS.

OPERATOR REQUIREMENTS:

1. Securely fasten seatbelt if the tractor has a ROPS.
2. Where possible, avoid operating the tractor near steep ditches, embankments, and holes.
3. Reduce speed when turning, crossing slopes, and on rough, slick, or muddy surfaces.
4. Stay off slopes too steep for safe operation.
5. Watch where you are going – especially at row ends, on roads, and around trees.
6. Do Not permit others to ride.
7. Operate the tractor smoothly – no jerky turns, starts, or stops.
8. Hitch only to the draw-bar and hitch points recommended by the tractor manufacturer.
9. When the tractor is stopped, set brakes securely and use park lock, if available



Printed in USA
© Tiger Corporation