



TWIN ROTARY ASSEMBLIES

JD 72-7510 CAB

Current as of 02/22/2010



1171

PARTS LISTING WITH MOUNTING AND OPERATING INSTRUCTIONS

Tiger Corporation
3301 N. Louise Ave.
Sioux Falls, SD 57107
1-800-843-6849
1-605-336-7900
www.tiger-mowers.com

33991

TO THE OWNER / OPERATOR / DEALER

All implements with moving parts are potentially hazardous. There is no substitute for a cautious, safe-minded operator who recognizes the potential hazards and follows reasonable safety practices. The manufacturer has designed this implement to be used with all its safety equipment properly attached to minimize the chance of accidents.

BEFORE YOU START!! Read the safety messages on the implement and shown in this manual. Observe the rules of safety and use common sense!

READ AND UNDERSTAND THIS MANUAL! Non-English speaking operators will need to GET THE MANUAL TRANSLATED as needed!



DANGER

FAILING TO FOLLOW SAFETY MESSAGES AND OPERATING INSTRUCTIONS CAN CAUSE SERIOUS BODILY INJURY OR EVEN DEATH TO OPERATOR AND OTHERS IN THE AREA.



1. Study and understand Operator's Manuals, Safety Decals, and Instructional Decals for tractor and implement to prevent misuse, abuse, and accidents. Practice before operating in a confined area or near passersby.

● Learn how to stop engine suddenly in an emergency. Be alert for passersby and especially children

2. Allow no children on or near folding mower or tractor. Allow no riders on tractor or implement. Falling off may cause serious injury or death from being run over by tractor or mower or contact with rotating blades.

3. Operate only with tractor having Roll-Over Protective Structure (ROPS) and with seat belt securely fastened to prevent injury and possible death from falling off or tractor overturn.

● Personal Protective Equipment such as Hard Hat, Safety Glasses, Safety Shoes, & Ear Plugs are recommended.

4. Block up or support raised machine and all lifted components securely before putting hands or feet under or working underneath any lifted component to prevent crushing injury or death from sudden dropping or inadvertent operation of controls. Make certain area is clear before lowering or folding

5. Before transporting, put Lift Lever in detent or full-lift position. Install Transport Safety Devices securely on folding mowers. Put Booms securely in Transport Rest.

● Folding and Boom Mowers have raised center of gravity. Slow down when turning and on hillsides.

6. Make certain that SMV sign, warning lights, and reflectors are clearly visible. Follow local traffic codes.

7. Never operate with Cutting Head or Folding Section raised if passersby, bystanders, or traffic are in the area to reduce possibility of injury or death from objects thrown by Blades under Guards or mower structure.

8. Before dismounting, secure implement in transport position or lower to ground.

● Put tractor in park or set brake, disengage PTO, stop engine, remove key, and wait until noise of rotation has ceased to prevent crushing by entanglement in rotating parts which could cause injury or death.

● Never mount or dismount a moving vehicle. Crushing from rollover may cause serious injury or death.



02967827

Warranty Information: Read and understand the complete Warranty Statement found in this manual. Fill out the Warranty Registration form in full and return it within 90 days. Make certain the Serial Number of the machine is recorded on the Warranty Card, and form that you retain.

FORWARD

This manual contains information about many features of the Tiger mowing and roadside maintenance equipment. Some of these include: Safety precautions, Assembly instructions, Operations, Maintenance and Parts. This manual will also assist you in the proper break-in, daily care, and troubleshooting of your new mower.

We recommend that you read carefully the entire manual before operating the unit. Also, time spent in becoming fully acquainted with its performance features, adjustments, and maintenance schedules will be repaid in a long and satisfactory life of the equipment.

Troubleshooting - Please, before you call, help us to help you!

Please look at the equipment to observe what is happening, then:

- Classify the problem
 - Hydraulic, electrical or mechanical - Read the trouble shooting section
 - Tractor or Truck chassis - Contact vehicle dealer

- If unable to correct the problem yourself, contact your local Tiger Dealer after gathering:
 - Machine model _____
 - Serial number _____
 - Dealer name _____
 - Detailed information about the problem including results of troubleshooting

Attention Owner / Operator / Dealer It is your obligation to read, and understand, the warranty information section located at the back of this manual denoting that the purchaser understands the safety issues relating to this machine and has received and will read a copy of this manual.

If at any time, you have a service problem with your Tiger mower, Contact your local dealer for service and parts needed.

MANUFACTURED BY:

Tiger Corporation

3301 N. Louise Ave.

Sioux Falls, SD 57107

1-800-843-6849

1-605-336-7900

www.tiger-mowers.com

DISTRIBUTED BY:

1-_____-_____-_____

1-_____-_____-_____

TABLE OF CONTENTS

| | |
|--|------------|
| SAFETY _____ | 1-1 |
| Safety Information_____ | 1-2 |
| ASSEMBLY / MOUNTING SECTION _____ | 2-1 |
| OPERATION SECTION _____ | 3-1 |
| MAINTENANCE SECTION _____ | 4-1 |
| PARTS SECTION _____ | 5-1 |
| Parts Ordering Guide_____ | 5-2 |
| Parts Table of Contents_____ | 5-3 |
| Common Parts Section _____ | 6-1 |
| WARRANTY INFORMATION _____ | 7-1 |



1012

This symbol means:

CAUTION – YOUR SAFETY IS AT RISK!

When you see this symbol, read and follow the associated instructions carefully or personal injury or damage may result.

Tiger is a registered trademark.



SAFETY

SAFETY SECTION

SAFETY

General Safety Instructions and Practices

A safe and careful operator is the best operator. Safety is of primary importance to the manufacturer and should be to the owner / operator. Most accidents can be avoided by being aware of your equipment, your surroundings, and observing certain precautions. The first section of this manual includes a list of Safety Messages that, if followed, will help protect the operator and bystanders from injury or death. Read and understand these Safety Messages before assembling, operating or servicing this mower. This equipment should only be operated by those persons who have read the Manual, who are responsible and trained, and who know how to do so safely and responsibly.



1000

The Safety Alert Symbol combined with a Signal Word, as seen below, is used throughout this manual and on decals which are attached to the equipment. The Safety Alert Symbol means: **“ATTENTION! BECOME ALERT! YOUR SAFETY IS INVOLVED!”** The symbol and signal word are intended to warn the owner / operator of impending hazards and the degree of possible injury when operating this equipment.

Practice all usual and customary safe working precautions and above all -- remember safety is up to YOU! Only YOU can prevent serious injury or death from unsafe practices.

DANGER!



Indicates an imminently hazardous situation that, if not avoided, WILL result in DEATH OR VERY SERIOUS INJURY.

WARNING!



Indicates an imminently hazardous situation that, if not avoided, COULD result in DEATH OR SERIOUS INJURY.

CAUTION!



Indicates an imminently hazardous situation that, if not avoided, MAY result in MINOR INJURY.

IMPORTANT!

Identifies special instructions or procedures that, if not strictly observed, could result in damage to, or destruction of the machine, attachments or the environment.

NOTE: *Identifies points of particular interest for more efficient or convenient operation or repair.* (SG-1)

READ, UNDERSTAND, and FOLLOW the following Safety Messages. Serious injury or death may occur unless care is taken to follow the warnings and instructions stated in the Safety Messages. Always use good common sense to avoid hazards. (SG-2)

SAFETY INSTRUCTIONS



SAFETY

PELIGRO!



Si no lee Ingles, pida ayuda a alguien que si lo lea para que le traduzca las medidas de seguridad. (SG-3)

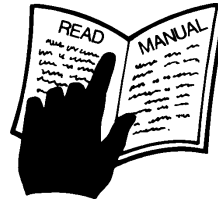

¡ LEA EL INSTRUCTIVO!

DANGER!



Never operate the Tractor or Implement until you have read and completely understand this Manual, the Tractor Operator's Manual, and each of the Safety Messages found in the Manual or on the Tractor and Implement. Learn how to stop the tractor engine suddenly in an emergency. Never allow inexperienced or untrained personnel to operate the Tractor and Implement without supervision. Make sure the operator has fully read and understands the manuals prior to operation. (SG-4)



WARNING!



Always maintain the safety decals in good readable condition. If the decals are missing, damaged, or unreadable, obtain and install replacement decals immediately. (SG-5)

WARNING!



Make certain that the "Slow Moving Vehicle" (SMV) sign is installed in such a way as to be clearly visible and legible. When transporting the Equipment use the Tractor flashing warning lights and follow all local traffic regulations. (SG-6)



WARNING!



Operate this Equipment only with a Tractor equipped with an approved roll-over-protective system (ROPS). Always wear seat belts. Serious injury or even death could result from falling off the tractor--particularly during a turnover when the operator could be pinned under the ROPS. (SG-7)



WARNING!



Do not modify or alter this Implement. Do not permit anyone to modify or alter this Implement, any of its components or any Implement function. (SG-8)

DANGER!



BEFORE leaving the tractor seat, always engage the brake and/or set the tractor transmission in parking gear, disengage the PTO, stop the engine, remove the key, and wait for all moving parts to stop. Place the tractor shift lever into a low range or parking gear to prevent the tractor from rolling. Never dismount a Tractor that is moving or while the engine is running. Operate the Tractor controls from the tractor seat only. (SG-9)



SAFETY

DANGER!



Never allow children or other persons to ride on the Tractor or Implement. Falling off can result in serious injury or death.

(SG-10)



DANGER!



Never allow children to operate or ride on the Tractor or Implement.

(SG-11)



WARNING!



Do not mount the tractor while the tractor is moving. Mount the tractor only when the tractor and all moving parts are completely stopped.

(SG-12)



DANGER!



Start tractor only when properly seated in the tractor seat. Starting a tractor in gear can result in injury or death. Read the tractor operators manual for proper starting instructions.

(SG-13)



DANGER!



Never work under the Implement, the framework, or any lifted component unless the Implement is securely supported or blocked up to prevent sudden or inadvertent falling which could cause serious injury or even death.

(SG-14)



DANGER!



Do not operate this Equipment with hydraulic oil leaking. Oil is expensive and its presence could present a hazard. Do not check for leaks with your hand! Use a piece of heavy paper or cardboard. High-pressure oil streams from breaks in the line could penetrate the skin and cause tissue damage including gangrene. If oil does penetrate the skin, have the injury treated immediately by a physician knowledgeable and skilled in this procedure.

(SG-15)



SAFETY

WARNING!



The operator and all support personnel should wear hard hats, safety shoes, safety glasses, and proper hearing protection at all times for protection from injury including injury from items thrown by the equipment. (SG-16)

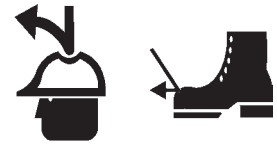

CAUTION!



PROLONGED EXPOSURE TO LOUD NOISE MAY CAUSE PERMANENT HEARING LOSS! Tractors with or without an Implement attached can often be noisy enough to cause permanent hearing loss. We recommend that you always wear hearing protection if the noise in the operator's position exceeds 80db. Noise over 85db over an extended period of time will cause severe hearing loss. Noise over 90db adjacent to the operator over an extended period of time will cause permanent or total hearing loss. *Note:* Hearing loss from loud noise [from tractors, chain saws, radios, and other such sources close to the ear] is cumulative over a lifetime without hope of natural recovery. (SG-17)



WARNING!



Transport only at safe speeds. Serious accidents and injuries can result from operating this equipment at unsafe speeds. Understand the Tractor and Implement and how it handles before transporting on streets and highways. Make sure the Tractor steering and brakes are in good condition and operate properly.

Before transporting the Tractor and Implement, determine the safe transport speeds for you and the equipment. Make sure you abide by the following rules:

1. Test the tractor at a slow speed and increase the speed slowly. Apply the brakes smoothly to determine the stopping characteristics of the Tractor and Implement. As you increase the speed of the Tractor the stopping distance increases. Determine the maximum safe transport speed for you and this equipment.
2. Test the equipment at a slow speed in turns. Increase the speed through the turn only after you determine that it is safe to operate at a higher speed. Use extreme care and reduce your speed when turning sharply to prevent the tractor and implement from turning over. Determine the maximum safe turning speed for you and this equipment before operating on roads or uneven ground.
3. Only transport the Tractor and Implement at the speeds that you have determined are safe and which allow you to properly control the equipment.



Be aware of the operating conditions. Do not operate the Tractor with weak or faulty brakes. When operating down a hill or on wet or rain slick roads, the braking distance increases: use extreme care and reduce your speed. When operating in traffic always use the Tractor's flashing warning lights and reduce your speed. Be aware of traffic around you and watch out for the other guy. (SG-19)

SAFETY

WARNING!



Never attempt to lubricate, adjust, or remove material from the Implement while it is in motion or while tractor engine is running. Make sure the tractor engine is **OFF** before working on the Implement.

(SG-20)

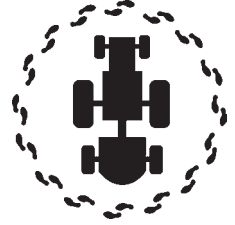

WARNING!



Periodically inspect all moving parts for wear and replace when necessary with authorized service parts. Look for loose fasteners, worn or broken parts, and leaky or loose fittings. Make sure all pins are properly secured. Serious injury may occur from not maintaining this machine in good working order. (SG-21)



WARNING!



Always read carefully and comply fully with the manufacturers instructions when handling oil, solvents, cleansers, and any other chemical agent. (SG-22)



DANGER!



Never run the tractor engine in a closed building or without adequate ventilation. The exhaust fumes can be hazardous to your health.

(SG-23)

DANGER!



KEEP AWAY FROM ROTATING ELEMENTS to prevent entanglement and possible serious injury or death. (SG-24)



DANGER!



Never allow children to play on or around Tractor or Implement. Children can slip or fall off the Equipment and be injured or killed. Children can cause the Implement to shift or fall crushing themselves or others. (SG-25)

SAFETY

DANGER!



NEVER use drugs or alcohol immediately before or while operating the Tractor and Implement. Drugs and alcohol will affect an operator's alertness and coordination and therefore affect the operator's ability to operate the equipment safely. Before operating the Tractor or Implement, an operator on prescription or over-the-counter medication must consult a medical professional regarding any side effects of the medication that would hinder their ability to operate the Equipment safely. **NEVER** knowingly allow anyone to operate this equipment when their alertness or coordination is impaired. Serious injury or death to the operator or others could result if the operator is under the influence of drugs or alcohol. (SG-27)

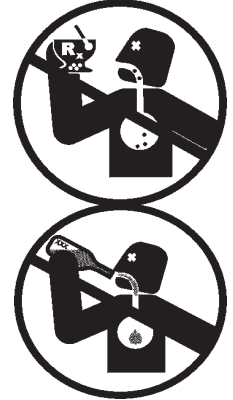

DANGER!



Operate the Tractor and/or Implement controls only while properly seated in the Tractor seat with the seat belt securely fastened around you. Inadvertent movement of the Tractor or Implement may cause serious injury or death. (SG-29)

WARNING!



Mow only in conditions where you have clear visibility in daylight or with adequate artificial lighting. Never mow in darkness or foggy conditions where you cannot clearly see at least 100 yards in front and to the sides of the tractor and mower. Make sure that you can clearly see and identify passersby, steep slopes, ditches, drop-offs, overhead obstructions, power lines, debris and foreign objects. If you are unable to clearly see this type of items discontinue mowing. (SGM-1)

DANGER!



There are obvious and hidden potential hazards in the operation of this Mower. **REMEMBER!** This machine is often operated in heavy brush and in heavy weeds. The Blades of this Mower can throw objects if shields are not properly installed and maintained. Serious injury or even death may occur unless care is taken to insure the safety of the operator, bystanders, or passersby in the area. Do not operate this machine with anyone in the immediate area. Stop mowing if anyone is within 100 yards of mower. (SGM-2)



DANGER!



All Safety Shields, Guards and Safety devices including (but not limited to) - the Deflectors, Steel Guards, Gearbox Shields, PTO integral shields, and Retractable Door Shields should be used and maintained in good working condition. All safety devices should be inspected carefully at least daily for missing or broken components. Missing, broken, or worn items must be replaced at once to reduce the possibility of injury or death from thrown objects, entanglement, or blade contact. (SGM-3)

SAFETY

DANGER!



The rotating parts of this machine have been designed and tested for rugged use. However, the blades could fail upon impact with heavy, solid objects such as metal guard rails and concrete structures. Such impact could cause the broken objects to be thrown outward at very high velocities. To reduce the possibility of property damage, serious injury, or even death, never allow the cutting blades to contact such obstacles. (SGM-4)

WARNING!



Extreme care should be taken when operating near loose objects such as gravel, rocks, wire, and other debris. Inspect the area before mowing. Foreign objects should be removed from the site to prevent machine damage and/or bodily injury or even death. Any objects that cannot be removed must be clearly marked and carefully avoided by the operator. Stop mowing immediately if blades strike a foreign object. Repair all damage and make certain rotor or blade carrier is balanced before resuming mowing. (SGM-5)



WARNING!



Many varied objects, such as wire, cable, rope, or chains, can become entangled in the operating parts of the mower head. These items could then swing outside the housing at greater velocities than the blades. Such a situation is extremely hazardous and could result in serious injury or even death. Inspect the cutting area for such objects before mowing. Remove any like object from the site. Never allow the cutting blades to contact such items. (SGM-6)

WARNING!



Mow at the speed that you can safely operate and control the tractor and mower. Safe mowing speed depends on terrain condition and grass type, density, and height of cut. Normal ground speed range is from 0 to 5 mph. Use slow mowing speeds when operating on or near steep slopes, ditches, drop-offs, overhead obstructions, power lines, or when debris and foreign objects are to be avoided. (SGM-7)

WARNING!



Avoid mowing in reverse direction when possible. Check to make sure there are no persons behind the mower and use extreme care when mowing in reverse. Mow only at a slow ground speed where you can safely operate and control the tractor and mower. Never mow an area that you have not inspected and removed debris or foreign material. (SGM-8)

WARNING!



Do not put hands or feet under mower decks. Blade Contact can result serious injury or even death. Stay away until all motion has stopped and the decks are securely blocked up. (SGM-9)



DANGER!



Replace bent or broken blade with new blades. NEVER ATTEMPT TO STRAIGHTEN OR WELD ON BLADES SINCE THIS WILL LIKELY CRACK OR OTHERWISE DAMAGE THE BLADE WITH SUBSEQUENT FAILURE AND POSSIBLE SERIOUS INJURY FROM THROWN BLADES. (SGM-10)

WARNING!



Do not mow with two machines in the same area except with Cab tractors with the windows closed. (SGM-11)

SAFETY

DANGER!



Rotary Mowers are capable under adverse conditions of throwing objects for great distances (100 yards or more) and causing serious injury or death. Follow safety messages carefully.

STOP MOWING IF PASSERSBY ARE WITHIN 100 YARDS UNLESS:

- Front and Rear Deflectors are installed and in good, working condition;
- Mower Head is running close to and parallel to the ground without exposed Blades;
- Passersby are outside the existing thrown-object zone;
- All areas have been thoroughly inspected and all foreign material such as rocks, cans, glass, and general debris has been removed.



NOTE: Where there are grass and weeds high enough to hide debris that could be struck by the blades, the area should be: inspected and large debris removed, mowed at an intermediate height, inspected closely with any remaining debris being removed, and mowed again at desired final height. (SFM-6)

WARNING!



Each Rear Wheel must have a minimum of 1,000 pounds contact with the surface to prevent lateral instability and possible tip-over which could result in serious bodily injury or even death. Widen the wheel tread and add weights if needed. Refer to the mounting instructions or call Customer Service if you need assistance with Counterweight Procedure. (SFL-3)



WARNING!



Do not operate Mower if excessive vibration exists. Shut down PTO and the Tractor engine. Inspect the Mower to determine the source of the vibration. If Mower blades are missing or damaged replace them immediately. Do not operate the mower until the blades have been replaced and the Mower operates smoothly. Operating the Mower with excessive vibration can result in component failure and broken objects to be thrown outward at very high velocities. To reduce the possibility of property damage, serious injury, or even death, never allow the Mower to be operated with blades missing. (SFL-4)

WARNING!



Do not let the Blades turn when the Mower Deck is raised for any reason, including clearance or for turning. Raising the Mower deck exposes the Cutting Blades which creates a potentially serious hazard and could cause serious injury or even death from objects thrown from the Blades. (SRM-7)



WARNING!



Never leave Tractor and Implement unattended while the implement is in the lifted position. Accidental operation of lifting lever or a hydraulic failure may cause sudden drop of unit with injury or death by crushing. To properly park the implement when disconnecting it from the tractor, lower the stand and put the retaining pin securely in place, or put a secure support under the A-Frame. Lower the implement carefully to the ground. Do not put hands or feet under lifted components. (SPT-1)

SAFETY

WARNING!



Be particularly careful when transporting the Implement with the Tractor. Turn curves or go up hills only at a low speed and using a gradual steering angle. Rear mounted implements move the center of gravity to the rear and remove weight from the front wheels. Make certain, by adding front ballast, that at least 20% of the tractor's weight is on the front wheels to prevent rearing up, loss of steering control or Tractor tip-over. Slow down on rough or uneven surfaces to prevent loss of steering control which could result in property damage or possible injury. Do not transport unless 3-Point lift lever is fully raised and in the latched transport position. Dropping implement in transport can cause serious damage to the tractor and/or Implement and possibly cause the operator or others to be injured or killed. (S3PT-2)

WARNING!



The rotating parts of this machine continue to rotate even after the Tractor has been turned off. The operator should remain in his seat for 60 seconds after the brake has been set, the PTO disengaged, the tractor turned off, and all evidence of rotation has ceased. (SBM-5)

“Wait a minute...Save a life!”

DANGER!



There are obvious and hidden potential hazards in the operation of this Implement as in all power-driven or pulled equipment. REMEMBER! This machine is often operated in rough terrain conditions that include tall grass, weeds, gullies, holes, slopes, hidden obstructions and the like. Serious injury or even death may occur unless care is taken to assure the safety of the operator and bystanders in the area. Do not operate this machine with anyone in the immediate area. (S3PT-7)

WARNING!



Relieve hydraulic pressure prior to doing any maintenance or repair work on the Implement. Place the Implement on the ground or securely blocked up, disengage the PTO, and turn off the tractor engine. Push and pull the Remote Cylinder lever in and out several times prior to starting any maintenance or repair work. (S3PT-9)



DANGER!



This Implement is wider than the Tractor. Be careful when operating or transporting this equipment to prevent the Implement from running into or striking sign posts, guard rails, concrete abutments or other solid objects. Such an impact could cause the Implement and Tractor to pivot violently resulting in loss of steering control, serious injury, or even death. Never allow the Implement to contact obstacles. (S3PT-12)

DANGER!



The flail cutter shaft is designed for standard rotation (same rotation as the tractor wheels during forward travel). **Never operate the cutter shaft in the reverse rotation.** Operating this mower in reverse rotation may cause objects to be thrown out the front of the mower head.

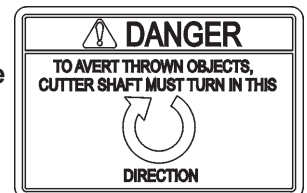

SAFETY

WARNING!



Engine Exhaust, some of its constituents, and certain components contain or emit chemicals known to the state of California to cause cancer and birth or other reproductive harm.

WARNING!



Battery posts, terminals and related accessories contain lead and lead compounds, chemicals known to the state of California to cause cancer and birth or other reproductive harm. **Wash hands after handling!**

Tiger mowers use balanced and matched system components for blade carriers, blades, cutter-shafts, knives, knife hangers, rollers, drive-train components and bearings. These parts are made and tested to Tiger specifications. Non-genuine “will fit” parts do not consistently meet these specifications. The use of “will fit” parts may reduce mower performance, void mower warranties and present a safety hazard. Use genuine Tiger mower parts for economy and safety.

SEE YOUR  DEALER

In addition to the design and configuration of this Implement, including Safety Signs and Safety Equipment, hazard control and accident prevention are dependent upon the awareness, concern, prudence, and proper training of personnel involved in the operation, transport, maintenance, and storage of the machine. Refer also to Safety Messages and operation instruction in each of the appropriate sections of the T ractor and Equipment Manuals. Pay close attention to the Safety Signs affixed to the T ractor and Equipment. (SG-18)

SAFETY

DO NOT LUBRICATE WITH AUTOMATIC GREASE GUN. GREASE WITH HAND GREASE GUN ONLY.

P/N22839

PART NO.
LOCATION

22839
MOWER DECK



22840
INSIDE OF CAB



24028

24028
MOWER DECK



10" x 5.5" 31522
MOWER DECK
18.25" x 10" 31523
HYDRAULIC TANK

SAFETY

PART NO.
LOCATION



42350
MOWER DECK

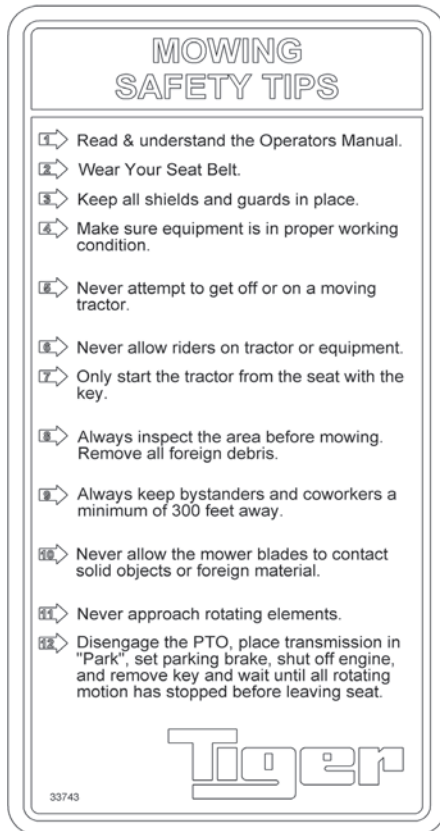

33743
INSIDE OF CAB



42399
MOWER DECK

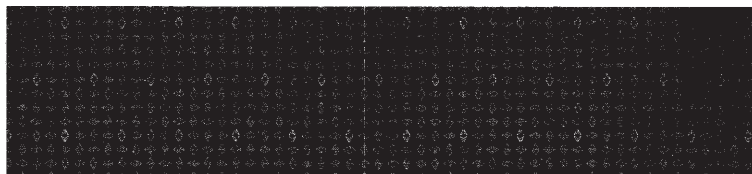

42400
MOWER DECK

SAFETY



PART NO.
LOCATION

6T3217
MOWER DECK

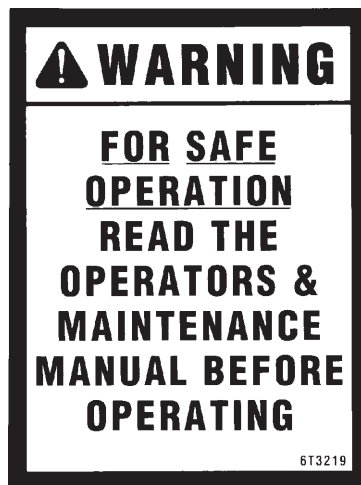

6T3219
INSIDE OF CAB

6T3220
FRONT PUMP MOUNT



6T3221
INSIDE OF CAB

SAFETY

NOTICE:
Engine will not start when mower is engaged.

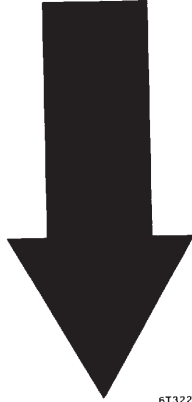

6T3222

PART NO.
LOCATION

6T3222
INSIDE OF CAB

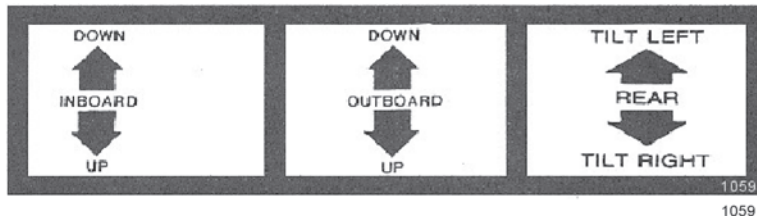

INSIDE OF CAB



6T3224
MOWER DECK

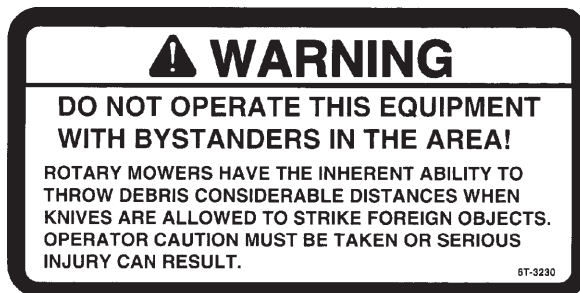

6T3230
INSIDE OF CAB

SAFETY

PART NO.
LOCATION



6T3233
HYDRAULIC TANK



6T3234
INSIDE OF CAB



6T3236
MOWER DECK
HYDRAULIC TANK



6T3243
INSIDE OF CAB

SAFETY

PART NO.
LOCATION

GREASING INSTRUCTIONS
CUTTER SHAFT BEARING
GREASE EVERY 8 HRS. OR DAILY

NOTE: If unusual environmental conditions exist-extreme temperatures, moisture, or contaminants-more frequent lubrication is required.

6T3249A

6T3249A
MOWER DECK

GREASING INSTRUCTIONS
GROUND ROLLER BEARING
GREASE EVERY 8 HRS. OR DAILY

NOTE: If unusual environmental conditions exist-extreme temperatures, moisture, or contaminants-more frequent lubrication is required.

6T3281

6T3261
MOWER DECK

 **WARNING**

DO NOT OPERATE MOWER
WITH SAFETY SHIELD REMOVED.

TB1011

TB1011
MOWER DECK

SAFETY



Tiger Corporation

800-843-6849

www.tiger-mowers.com

| Description | Application | General Specification | Recommended Lubricant |
|---|-------------|--|--|
| Tractor Hydraulics | Reservoir | JD-20C | Mobilfluid® 424 |
| Mower Hydraulics Cold Temperatures 0°F Start-up Normal Temperatures 10°F Start-up Normal Temperatures 15°F Start-up High Operating Temperatures Above 90°F Ambient | Reservoir | ISO 46 Anti-Wear/ Low Temp JD-20C ISO 46 Anti-Wear ISO 100 Anti-Wear | Mobil DTE® 15M Mobilfluid® 424 Mobil DTE® 25 Mobil DTE® 18M |
| Flail Rear Gearbox | Reservoir | PAO Synthetic Extreme Pressure Gear Lube | Mobilube SHC® 75W-90, Mobil 1 Synthetic Gear Lubricant |
| Cutter Shaft and Ground Roller Shaft (Flail) | Grease Gun | Lithium Complex, NLGI 2 ISO 320 | Mobilgrease® CM-S |
| Drive Shaft Coupler (Rotary and Flail) | Grease Gun | Lithium Complex, NLGI 2 ISO 320 | Mobilgrease® CM-S |
| Boom Swivel, Boom Cylinder Pivots (Rotary and Flail Boom Type) | Grease Gun | Lithium Complex, NLGI 2 ISO 320 | Mobilgrease® CM-S |
| Deck Boom Pivot & Deck Stop Adjustment (Rotary and Flail) | Grease Gun | Lithium Complex, NLGI 2 ISO 320 | Mobilgrease® CM-S |
| Deck Spindle (Rotary) | Grease Gun | Tiger Spindle Lubricant | Mobilith SHC 220 |

For Mobil product information, availability, or technical information, call 1-800-662-4525.

Tiger PN 34852

34852
HYDRAULIC TANK

SAFETY

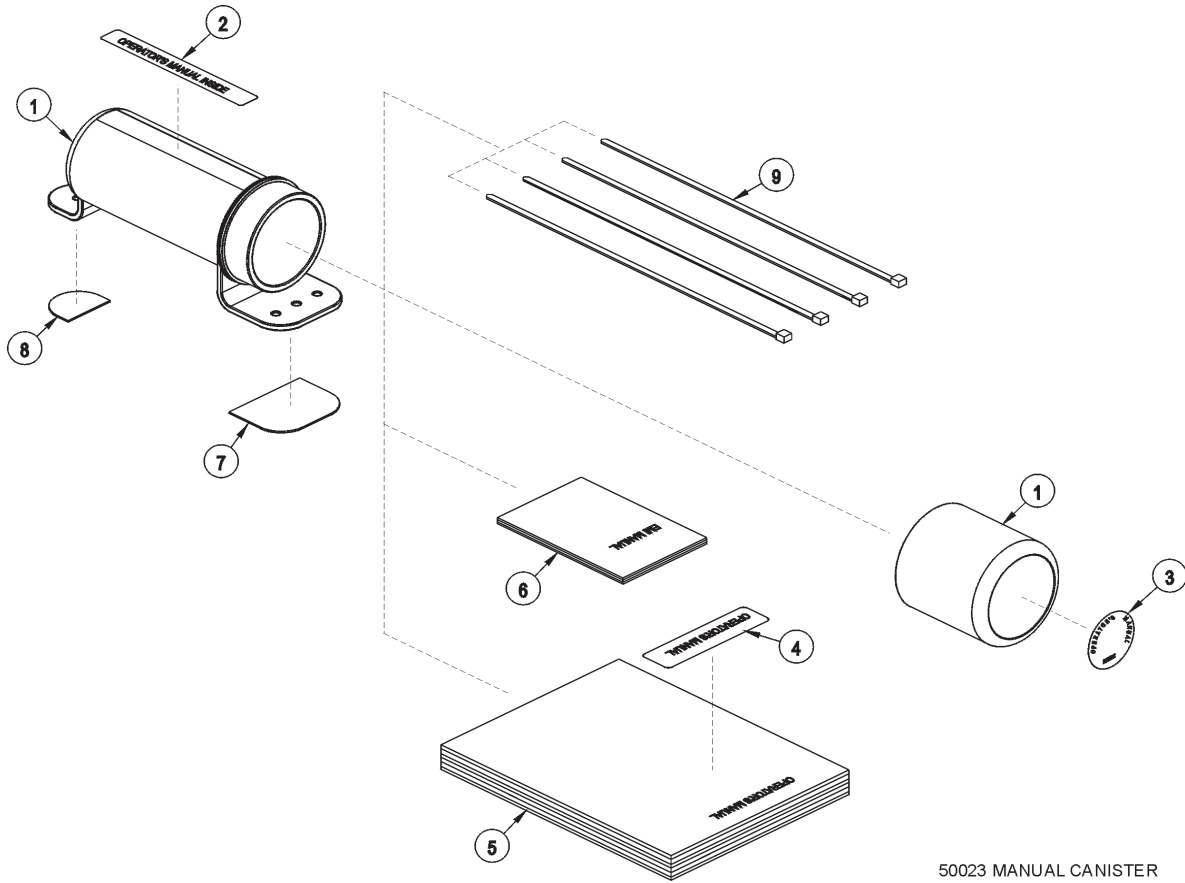

50023 MANUAL CANISTER

| ITEM | PART NO. | QTY. | DESCRIPTION |
|------|--------------|--------------|---------------------------------|
| | 50023 | AVAIL | MANUAL CANISTER COMPLETE |
| 1 | 00776031 | 1 | ROUND MANUAL CANISTER |
| 2 | 33997 | 1 | DECAL, SHEET, MANUAL CANISTER |
| 3 | | * | DECAL |
| 4 | | * | DECAL |
| 5 | * | AVAIL | SPECIFIC PRODUCT MANUAL |
| 6 | 33753 | 1 | E M I SAFETY MANUAL |
| 7 | 34296 | 1 | FRONT ADHESIVE PAD |
| 8 | 34297 | 1 | REAR ADHESIVE PAD |
| 9 | 6T1823 | 4 | ZIPTIE 14" LONG |

NOTE:

The manual canister can be bolted, zip tied or adhered to a variety of surfaces. Locate a protected area within the view of the operator. Then select an installation method and attach the canister. **CAUTION - AVOID DRILLING HOLES INTO UNKNOWN AREAS**, wires and other parts may be located behind these areas. When adhering the canister to a surface, thoroughly clean that surface before installing the canister.

SAFETY

FEDERAL LAWS AND REGULATIONS

This section is intended to explain in broad terms the concept and effect of federal laws and regulations concerning employer and employee equipment operators. This section is not intended as a legal interpretation of the law and should not be considered as such.

Employer-Employee Operator Regulations

U.S. Public Law 91-596 (The Williams-Steiger Occupational and Health Act of 1970) OSHA

This Act Seeks:

“...to assure so far as possible every working man and woman in the nation safe and healthful working conditions and to preserve our human resources...”

DUTIES

Sec. 5 (a) Each employer-

(1) shall furnish to each of his employees employment and a place of employment which are free from recognized hazards that are causing or are likely to cause death or serious physical harm to his employees;

(2) shall comply with occupational safety and health standards promulgated under this Act.

(b) Each employee shall comply with occupational safety and health standards and all rules, regulations and orders issued pursuant to this Act which are applicable to his own actions and conduct.

OSHA Regulations

OSHA regulations state in part: “At the time of initial assignment and at least annually thereafter, the employer shall instruct every employee in the safe operation and servicing of all equipment with which the employee is, or will be involved.”

Employer Responsibilities:

To ensure employee safety during Tractor and Implement operation, it is the employer's responsibility to:

1. Train the employee in the proper and safe operation of the Tractor and Implement.
2. Require that the employee read and fully understand the Tractor and Implement Operator's manual.
3. Permit only qualified and properly trained employees to operate the Tractor and Implement.
4. Maintain the Tractor and Implement in a safe operational condition and maintain all shields and guards on the equipment.
5. Ensure the Tractor is equipped with a functional ROPS and seat belt and require that the employee operator securely fasten the safety belt and operate with the ROPS in the raised position at all times.
6. Forbid the employee operator to carry additional riders on the Tractor or Implement.
7. Provide the required tools to maintain the Tractor and Implement in a good safe working condition and provide the necessary support devices to secure the equipment safely while performing repairs and service.

Child Labor Under 16 Years of Age

Some regulations specify that no one under the age of 16 may operate power machinery. It is your responsibility to know what these regulations are in your own area or situation. (Refer to U.S. Dept. of Labor, Employment Standard Administration, Wage & Home Division, Child Labor Bulletin #102.)

ASSEMBLY SECTION

ASSEMBLY

Before attempting to mount or service your Tiger mower, it is important to read and understand all of the information in the Safety section of this manual.

Check complete shipment list against the packing list to make sure there are no shortages. Make certain the tractor model is the appropriate one for the mower received!

CAUTION!



Use a floor jack, hoist or fork lift to lift or raise heavy parts whenever possible whether mentioned or not.

Read and understand the entire assembly section instructions before attempting to mount your Tiger mower. Refer to the parts section of this manual for detailed illustrations to locate all parts.

TRACTOR PREPARATION

A: Remove right hand steps.

B: Remove engine side panels, or raise hood to access front pulley.

C: Remove plugs from tractor casting where main frame and pump mount will be attached.

CRANKSHAFT ADAPTER

If necessary remove the four cap-screws from the crankshaft pulley. Then install the crankshaft adapter and adapter plate to the pulley with cap-screws and lock-washers as shown in the parts section.

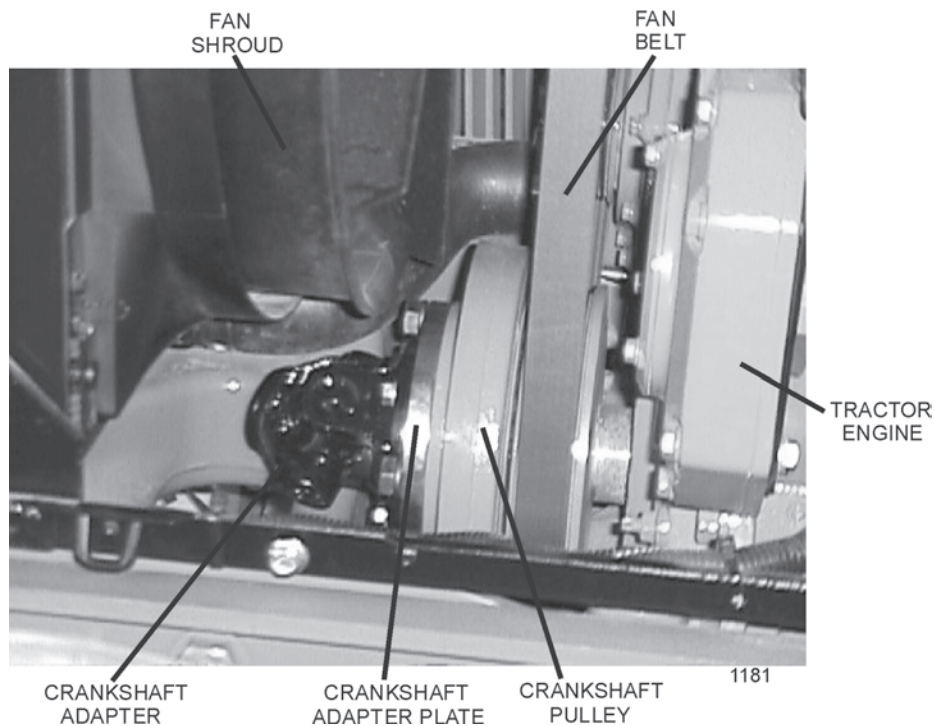

ASSEMBLY

ADJUSTING REAR WHEELS

Raise rear of tractor onto jack-stands. **Follow the instructions in the tractor owners manual for adjusting tires and rims** to 72" center for side mounted mowers and 79.8" for boom mowers. NOTE: This may require switching the wheels to opposite sides of tractor.

VALVE MOUNTING PLATE

With the right rear wheel removed, use the valve plate as a template to mark out the position for each of the three holes that will need to be drilled for mounting. The bottom two holes should be approximately $\frac{3}{4}$ " up in the lower cab support, the other will be $6\frac{7}{8}$ " up (again marking using plate as template).

Drill the two lower holes to $\frac{3}{8}$ " and align plate with holes to double check position of the upper hole. Drill the upper hole to $\frac{3}{8}$ ". After double checking holes are correct, fasten all mounting angles, hardware and the valve to the valve plate. The assembly can now be installed into the wheel well. Refer to the parts section for all parts and hardware needed.

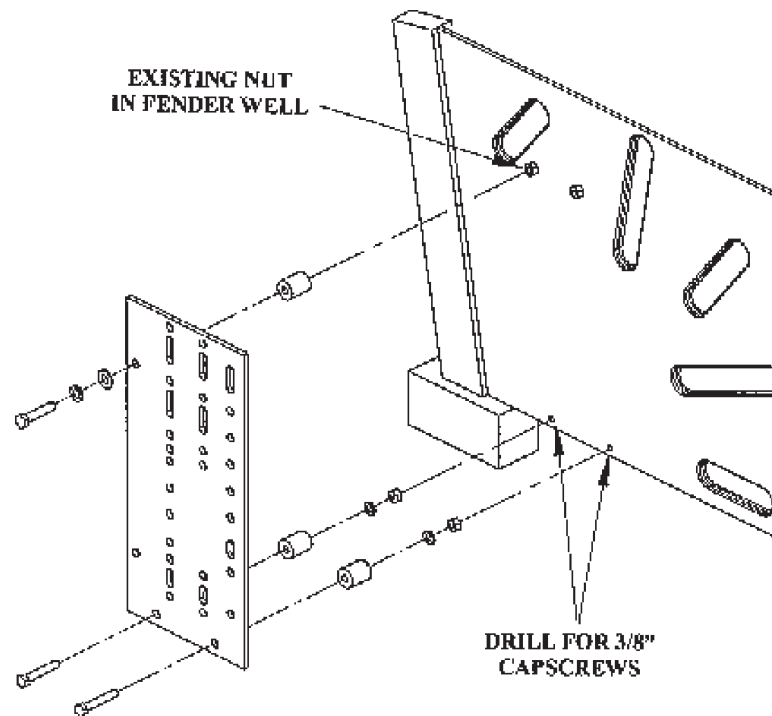

1089

Mount the valve plate to the tube above the cab post with the cap-screws, lock-washers, spacers, and hex nuts **as shown in the parts section. DO NOT tighten.**

Install the other two spacers with hardware through the fender well, and tighten all bolts in the valve plate.

ASSEMBLY

CABLE CONTROL LEVER STAND

On the corner cab post, mark a point at 1-3/8" from the windshield and 22 1/2" from the floor; then cut a 3/4" diameter hole through the outer plastic shell. This will expose a threaded steel boss to attach the control box support bracket.

The rear corner of the cable control stand is placed approximately 5 3/4" from the edge of the mat. The front edge of the stand is up against the corner cab post and the door sill lip of the mat. Before you mark or drill any holes, check for support plates or wires under the mat & the cab floor. **NOTE:** Cutting into plates or wires makes more work for everyone and could be dangerous. When you know where the wires/plates lie, mark one of the mounting holes. Drill a 3/8" hole through the mat and through the floor of the cab. Next, lift the mat up and mark the other two holes on the cab floor. Drill the holes through the floor. Mark the mat and drill the other two 3/8" holes. Use a 1" hole saw and cut a 1" hole through the mat over each 3/8" hole. Secure the stand to the floor with the spacers, capscrews and nylock nuts provided.

STAND PLACEMENT

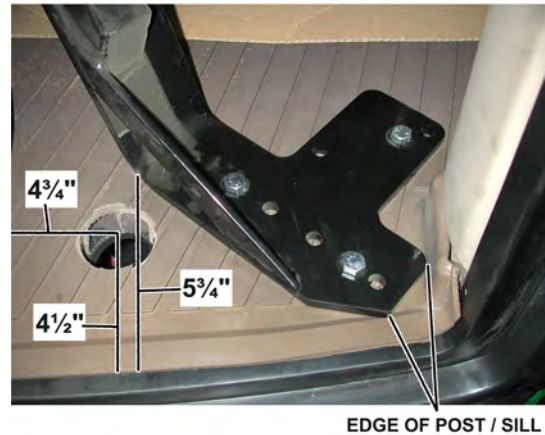

EDGE OF POST / SILL

UNDER FLOOR OF CAB

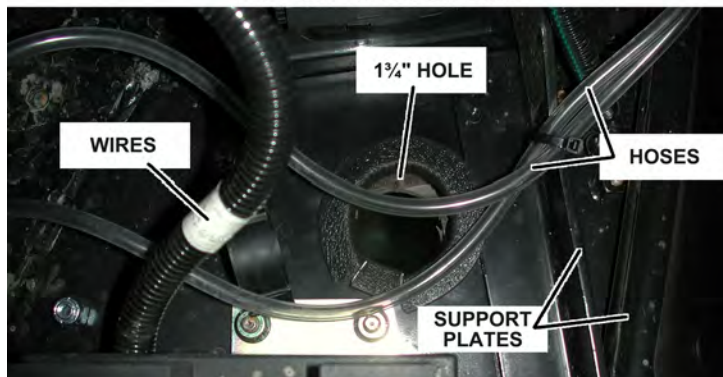

Cut a 1 3/4" hole in the floor to route the cables and wires through. It needs to have a 1/4" clearance for the trim lock. Before you mark or drill any holes, check for support plates or wires under the cab floor.

NOTE: Cutting into plates or wires makes more work for everyone and could be dangerous. Look under the floor for cables and plates that you need to avoid. The hole should be approximately 4 1/2" from the door sill and 4 3/4" from the lip of the mat under the console. Install the trim lock around the metal edges of the hole, then route the control cables and wires through the hole.



Next, wrap the cables with the 6" split hose at the point they pass through the hole, and secure the zip-ties. Apply RTV sealer in and around individual cables and split hose, inside and outside of the cab for a water tight seal. Install upper support bracket from cab post to the control lever stand.

ASSEMBLY

TWIN ROTARY HYDRAULIC DIAGRAM

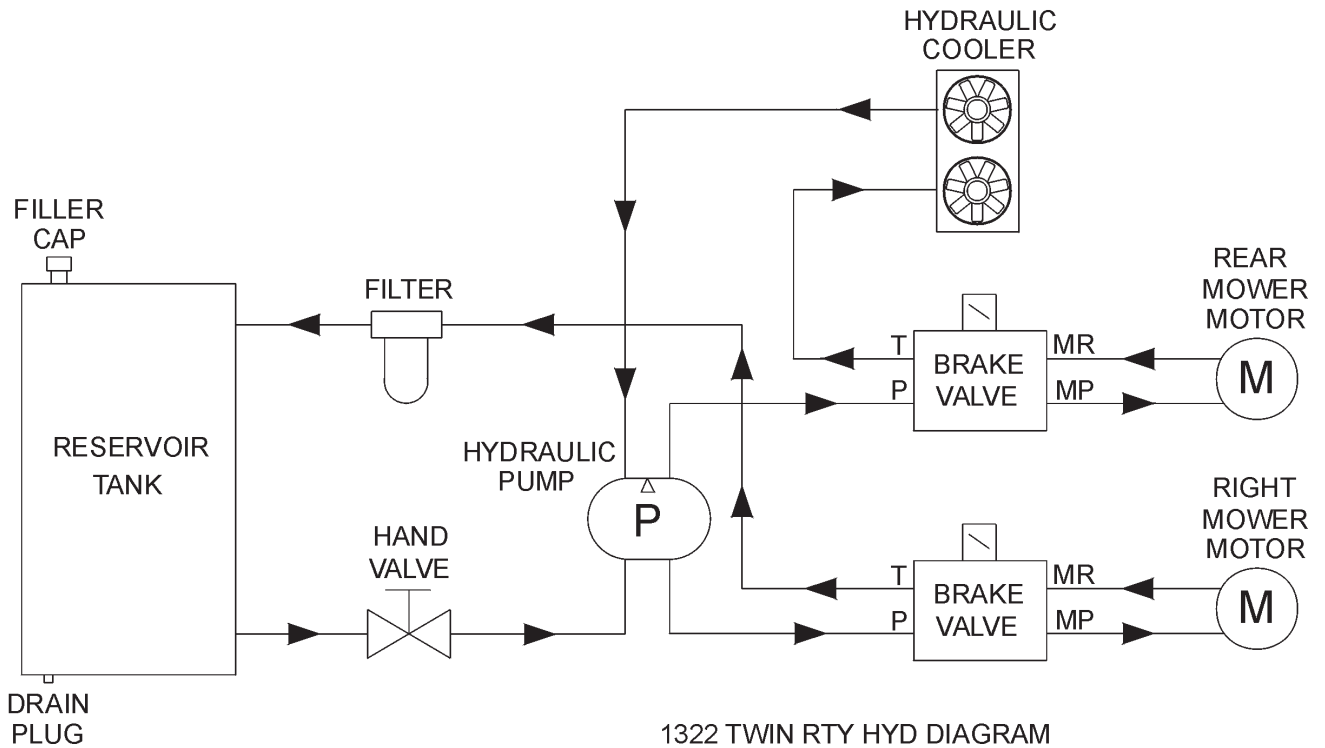
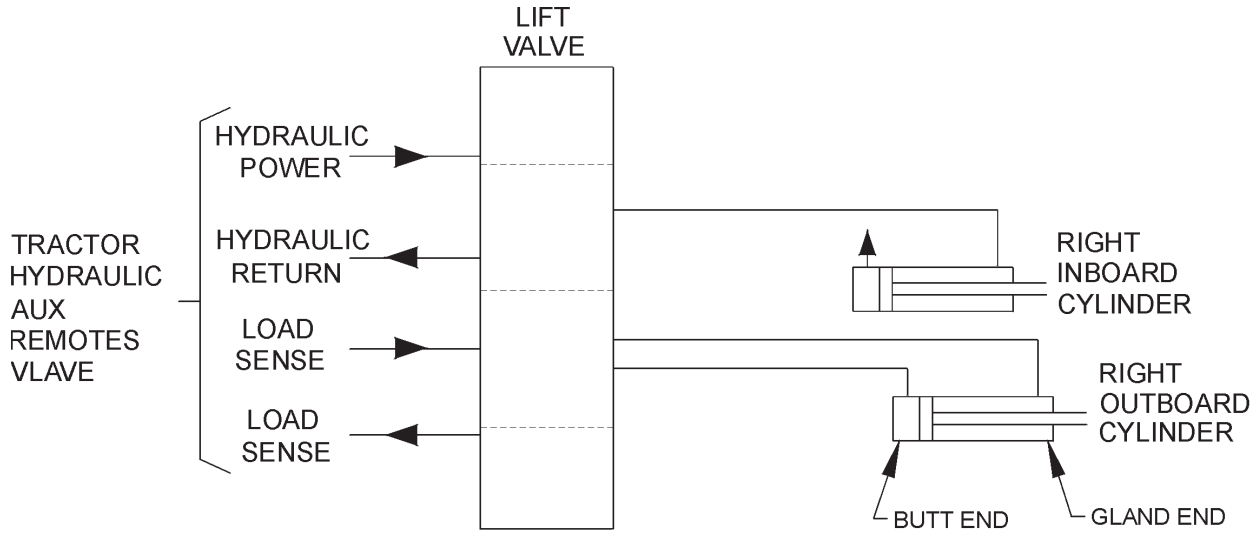

1322 TWIN RTY HYD DIAGRAM

ASSEMBLY

PRESSURE LINE INSTALLATION

The hydraulic pressure line will be plumbed into the rear of the tractor remote valve end cap. Locate the pressure port and remove the plug (refer to the illustration below and the Parts Section for position of the pressure port). After the plug is removed then connect a hose from the tractor remote valve to the Tiger lift valve.

RETURN LINE INSTALLATION

The return line will be plumbed in next to the pressure line in the tractor remote valve end cap. Locate the return port and remove the plug (refer to the illustration below and the Parts Section for the position of the return port). After the plug is removed then connect a hose from the tractor remote valve to the Tiger lift valve.

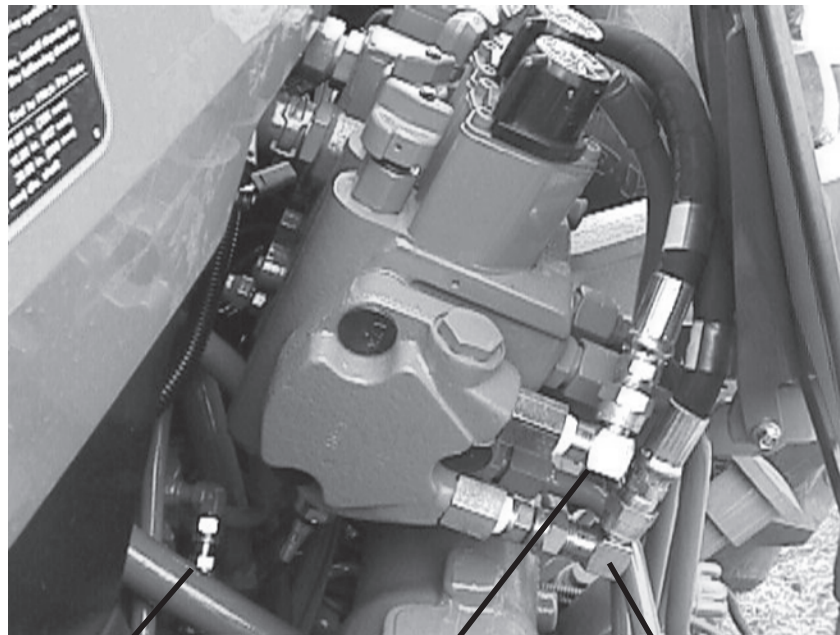

TRACTOR PUMP
LOAD SENSE
(LOAD SENSE - B)

PRESSURE LINE

RETURN LINE

ASSEMBLY

HUSCO LOAD SENSE LINE INSTALLATION

To install the load sense lines from a Husco lift valve to the tractor remote valve, first the existing load sense line located on the top of the tractor remote valve connecting "load sense - A" and "load sense - B" must be removed, in order so that the two load sense lines are able to be connected to the Husco lift valve. Next connect a 1/4" hose (load sense - A) to the top of tractor remote valve, then to the top front port on the Husco lift valve. Next connect a 1/4" hose (load sense - B) to the tractor pump load sense and the top rear port of the Husco lift valve.

This procedure is followed when mounting a Husco lift valve on a John Deere 72-7410. For more information refer to the Parts Section pages for a complete diagram of the tractor valve hookup.

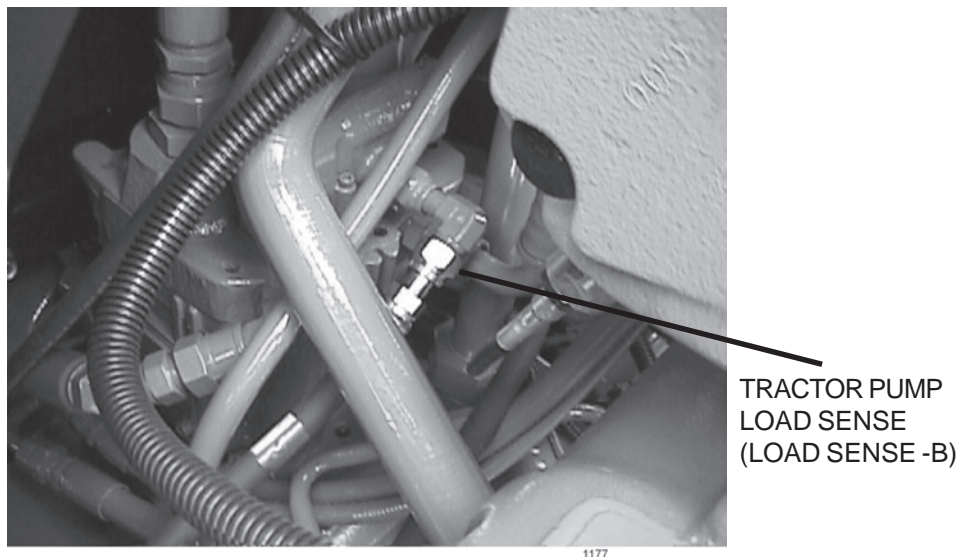
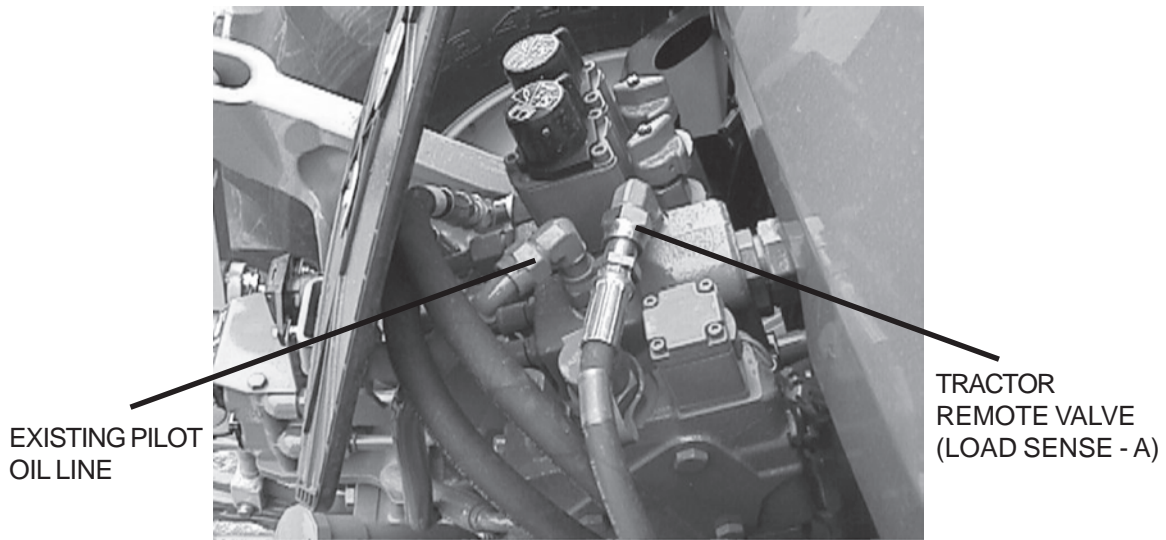

ASSEMBLY

SECTIONAL VALVE MOUNTING W/CAB

Refer to the boom lift valve assembly for hardware and placement of all related parts.

SECTIONAL VALVE MOUNTING WO/CAB

Refer to the boom lift valve assembly for hardware and location of components. First, attach control valve stand to the top of the main frame mast with cap-screws, lock-washers and hex nuts. **NOTE:** The mounting plate should face the rear of the tractor.

Attach the 4-spool control valve to the stand using the hardware noted in the parts section. One cap-screw must be used to secure the switch box to the under side of the valve stand.

SWITCH MOUNTING

Refer to the parts section for wiring diagrams. Remove right side cowl panel, tach panel, and hour meter panel for access to the wires.

Route the red wire from the switch box to the bare electrical plug in the fuse box, or other un-used "keyed" hot wire. **NOTE: +12 VOLTS ELECTRICAL POWER MUST BE TAKEN FROM A SOURCE LOCATION WHERE IT IS LIVE ONLY WHEN THE IGNITION SWITCH IS IN THE "ON" POSITION. THIS WIRE MUST BE FUSED AT THE SOURCE LOCATION.**

Drill a ½" hole in the 9" X 5" right side panel to route the green safety switch wires, and white wire to be connected to the hydraulic solenoid valve.

The switch box is to be secured to the operators side of the control handles, or valve stand.

The green wires will connect to the neutral safety switch, located on the back of the ignition switch, under the cowl panel.

TEMPERATURE GAUGE MOUNTING

(OPTIONAL)

Mount the temperature gauge where it is clearly visible to the operator. Attach the green (-) wire from the negative post on the gauge to a grounded bolt on the tractor frame. Remove paint if needed to make a good ground.

Remove the pipe plug from the side of the hydraulic reservoir, and install the temperature sensor using thread sealing tape.

Run the white wire from the (S) sensor post of the gauge to the temperature sensor on the hydraulic reservoir tank.

MAIN FRAME MOUNTING

Raise front of tractor as needed and slide the main frame under tractor from right hand side. With an overhead hoist and / or jack-stands, raise the frame up to the correctly matching mounting holes. Install cap-screws and all other hardware as shown in main frame parts section. Remove the cap-screws one at a time and apply a thread locking agent, then reinsert the cap-screws and tighten / torque to values noted in the torque chart located in the maintenance section of this manual.

ASSEMBLY

3-POINT DECK TILT CYLINDER

Remove the support cylinder from the left rear three point arm and replace with the cylinder, clevis ends, and pin furnished in the kit. See part section for parts and assembly.

HYDRAULIC TANK INSTALLATION

Install all fittings and tubes into tank and tank filter as shown in parts section illustration. Insert tank sight glass into front side of the tank. Install the temperature sensor or pipe plug into the side of the tank.

Place the tank in the mounting bracket on the main frame with fittings toward tractor and filter toward the cab.

Secure the tank in the mounting bracket with the tank strap and nylock nuts.

Install the filter gauge into the filter housing so that it points to the rear of the tractor and is clearly visible to the operator.

Locate the tank breather and reducer bushing (bushing may be already installed in the tank along with many of the for-mentioned parts). These will be installed after tank is filled.

FRONT PUMP MOUNTING

Install the pump mounting bracket on the front of the tractor with cap-screws and lock-washers as shown in the parts section illustration. DO NOT tighten fasteners at this time.

Thread the pump drive shaft into the crankshaft adapter.

Slide the splined drive shaft coupler onto the pump drive shaft. Install the pump onto the mounting bracket. NOTE: the pump is offset to one direction, the pump should be installed with the offset side on top. Install hardware for securing pump to the pump mount, DO NOT tighten.

Install pump and align so that splined coupling can be moved (FREE PLAY) back and forth by hand. Rotate coupler and check free play every 1/4 turn. Tighten pump mounting bolts in succession rechecking for spline coupling free play. Remove the pump mounting bracket bolts one at a time and apply a thread locking agent. Tighten these bolts in succession, again checking for free play in the drive shaft. After all bolts are torqued, the end play on the drive shaft should be 1/16" to 1/8", and coupler should move freely with hand pressure. If end play is less than 1/16", grind the end of the shaft to achieve the proper end play. If there is more than 1/4" of end play, return the shaft with specifications for a longer shaft.

CAUTION: DO NOT START THE TRACTOR UNTIL ALL HOSES ARE ATTACHED, TANK IS FILLED WITH PROPER OIL AND BALL VALVES ARE OPEN! STARTING AT THIS TIME WILL CAUSE SERIOUS DAMAGE TO THE PUMP.

GENERAL HOSE INSTALLATION

Refer to the parts section for detailed information about hoses and fittings for this application.

When mounting the suction hose between the pump and the tank, the stainless steel bands that are provided must be used. CAUTION: DO NOT use regular hose clamps for this purpose.

For protection of hoses in contact with metal edges, wrap hoses with spit hose sections and fasten with hose clamps or zip ties as needed.

ASSEMBLY

INSTALLING O-RING FITTINGS

Installing straight, 45 degree and 90 degree O-ring fittings requires that the O-ring, washer and nut (A) be up against the swivel body (B). Insert the swivel and turn in until the swivel is pointed in the right direction and the O-ring contact is made. Hold swivel in set direction with a wrench and turn the O-ring nut away from the swivel body and carefully tight

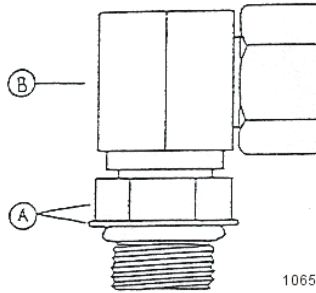

INSTALLING NATIONAL PIPE FITTINGS

Whenever installing a pipe fitting, wrap the threads clockwise (looking at the end) with teflon tape. In this way, the tape will be tightened when installed. NOTE: It is not necessary to tape O-ring fittings, or those installed in swivels.

CABLE LIFT DRAFT BEAM INSTALLATION

Install ½" O-ring breather into butt port of inboard cylinder. Install fittings in the rod end of the cylinder according to the diagram in the commons section. These fittings should be positioned to face the butt end of the cylinder.

Next turn the clevis onto the rod of the cylinder until it is tight against the shoulder and lock into place with locking bolt on clevis.

The inboard cylinder can now be installed into the main frame mast with the pin, flat-washers and R-clips as shown below. Use teflon tape on all fitting and hose connections.

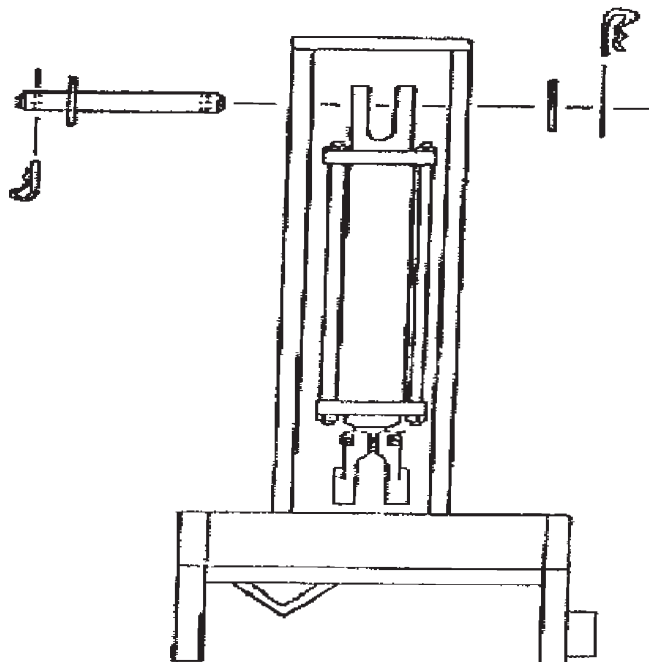

ASSEMBLY

DRAFT BEAM MOUNTING

Pull the inboard cylinder piston rod down to the extreme extended position. Slide the draft beam under the cylinder, and align clevis hole with draft beam hole nearest to the tractor. Install pin and secure with R-clips.

Using inboard cylinder as a pivot point, slide draft beam under tractor and install draft beam pin. Align hole in draft beam pin with holes in main frame boss and install cap-screw, lock-washer and hex nut.

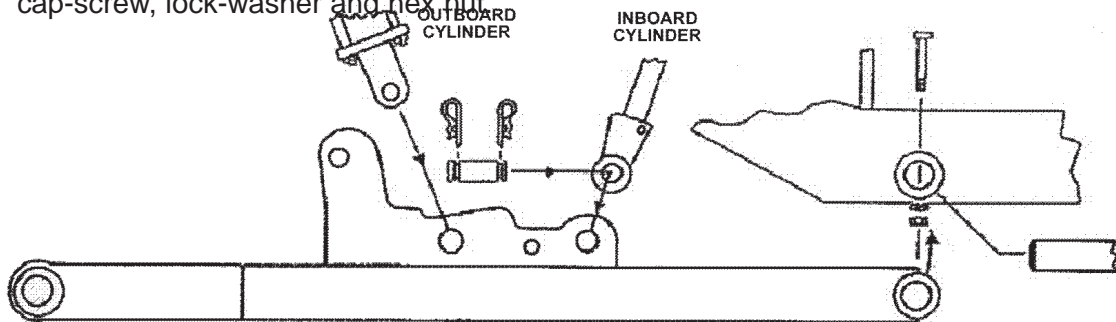

Install the fittings in the butt end of the outboard cylinder, as shown in the commons section. These should be positioned to face the rod end of the cylinder. Next, install the O-ring breather in the rod end of the cylinder.

Install the outboard cylinder in the hole in the draft beam as shown in the diagram on the previous page. Install the pin into the draft beam and cylinder and secure with R-clips.

LIFT CONTROL FEEDLINES

Hose lengths will vary between tractor applications such as cab and non-cab units. See the parts section that pertains to your tractor for hose applications.

Install a hose from the bottom or inner valve port (in fender well for cab units, on stand for non-cab units) to the restrictor on the inboard cylinder gland.

Install a hose from the upper or outer valve port to the restrictor on the outboard cylinder butt. Use teflon tape on all fitting and hose connections.

DECK / MOTOR FEEDLINE

Install the hose with the 90 degree #20 flange on one end between the front side of the motor to the bottom of the solenoid valve. Secure to motor with #20 flange kit.

Install the #20 flange adapter block to the back side of the motor and install swivel fittings. Install the hose from the fittings on the back of the motor to the top of the solenoid valve. Install split hoses around hydraulic hoses where they contact the edge of the head, or any other edges that may rub hoses.

Be sure that all grease zerks are installed in the draft beam pin bosses. Grease all areas of the draft beam according to the instructions in the maintenance section.

Re-check all fittings for tightness and be sure teflon tape has been used at all connections.

Fill hydraulic tank with fluid as recommended in the maintenance section. **BE SURE TO OPEN THE BALL VALVES.** Start the tractor and operate the inboard cylinder through the entire stroke and the outboard cylinder through the bottom $\frac{3}{4}$ stroke repeatedly to clear the lines of air. **DO NOT run outboard cylinder out to full stroke until turnbuckle has been adjusted!**

ASSEMBLY

Check for oil leaks at all fittings and connections using a piece of paper or cardboard. **DO NOT USE HANDS TO CHECK FOR FLUID LEAKS!**

Raise the tree point hitch and check the tractor internal hydraulics, fill to proper level if needed.

DECK MOUNTING AND LIFT ASSEMBLY

Install the upper sheave bracket on the outboard cylinder and tighten securely against piston rod shoulder. Tighten the set screw, and align the draft beam.

Install the lower sheave bracket on the draft beam with a $\frac{3}{4}$ " cap-screw and two hex nuts as shown in the diagram on the next page.

Align the deck with the draft beam mounting hole and install the outer draft beam pin. Align the holes in the draft beam pin with the holes in the boss and secure with cap-screw, lock-washer and hex nut.

Pass the lift cable through upper sheave bracket and attach to turn buckle with turn buckle pin and cotter key. Attach turn buckle to draft beam with turn buckle pin and cotter key.

Place the cable in the upper sheave bracket with the cable on top of the wheel. Secure wheel with sheave pin (with grease zerk) and R-clip. Place lift cable in lower sheave below the wheel and install sheave with pin (with grease zerk) and R-clip. Then install the

The cable can now be attached to the deck mounting bracket with the shackle. Tighten shackle pin securely. **NOTE: DO NOT tighten the turn buckle at this time!**

Refer to the commons section for further reference and part numbers.

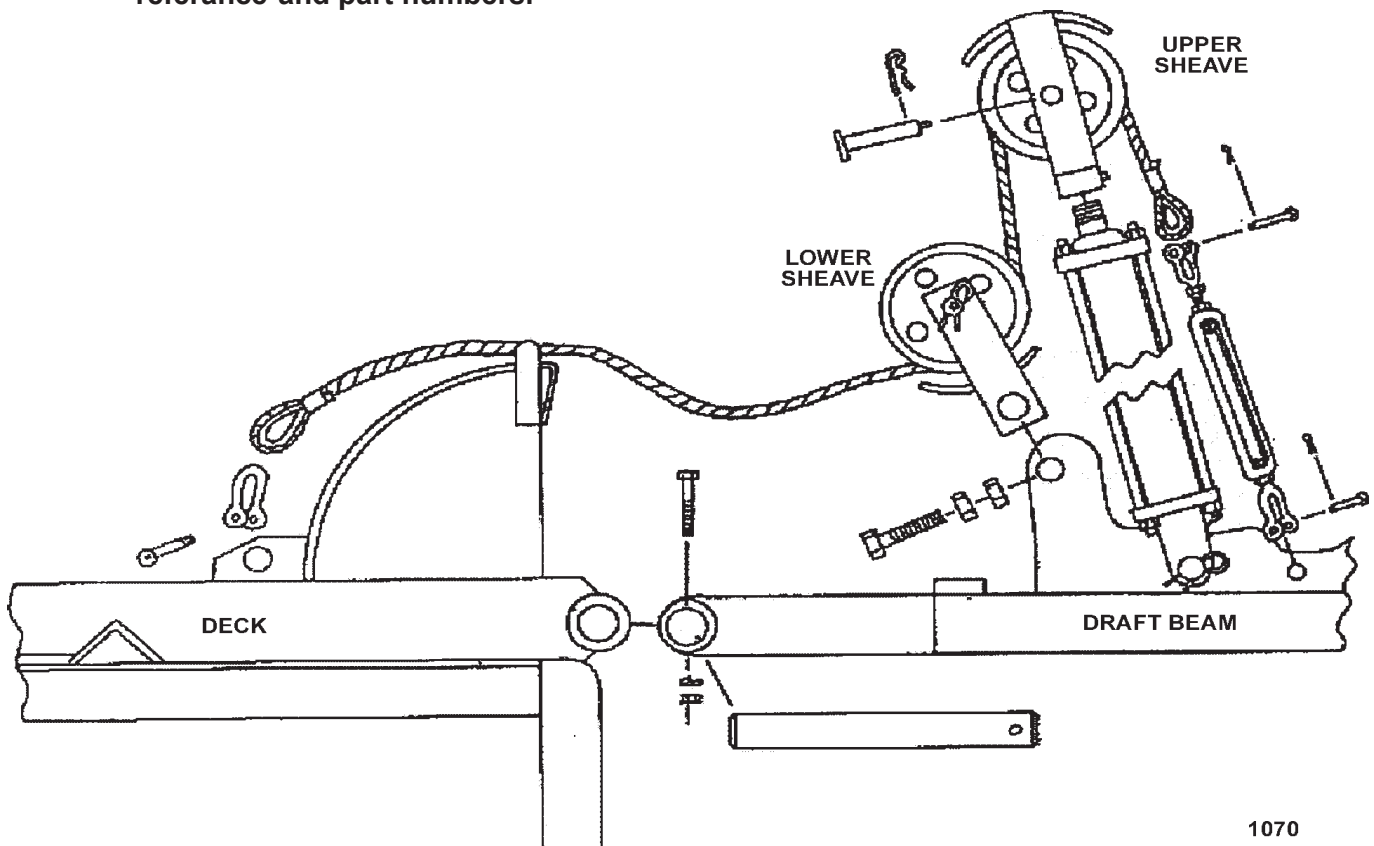

ASSEMBLY

TURNBUCKLE ADJUSTMENT

Extend the outboard cylinder until the deck touches the stop on the draft beam. Hold the deck in this position to adjust the lift cable tension. Adjust turn buckle until cable is tight.

Lower and raise the deck to check adjustment. The mower deck should reach it's stop on the draft beam at the same time the outboard cylinder reaches it's extreme extended position.

Finally tighten the turn buckle lock nuts securely. It will be necessary to readjust the turn buckle after the cable has stretched from use.

FINAL PREPARATION FOR OPERATION

Place operators safety and operation decals on the steering column and side counsel where they are clearly visible to the operator. These decals should be understood by each operator of the machine in conjunction with the safety and operation section of this book. The decals are to remain in good condition as a reminder to the operator, and should be replaced if damaged.

Double check that all pivot points have been greased. Secure all hoses together with zip ties and wrap with split hose sections where friction may occur on the hose.

WARNING!



BEFORE starting or operating the tractor you must read and understand the safety and operation sections of this manual completely.

Before operating the mower, the cutter head and draft beam should be slowly moved throughout the full range of motion. Watch for any condition that would cause pinching or excess stress on the hoses. The steering and front axle travel should also be carefully moved through their full range of motion. If any condition occurs in which the hoses contact the tires, the steering and / or front axle travel may need to be limited as described in the tractor operators manual. This should also be done if the tires rub, or are extremely close to any other part of the mower such as the hydraulic tank or draft beam. This may include adding shims, or adjusting stop bolts in the tractor front to solve the problem. While checking motion, you should also check that the control circuits are connected according to the operators decal for the valve handles.

MOWER TESTING

Take the tractor to a place free of loose objects on the ground. Operate the cylinders through their full range of motion again, to clear the lines of air. Follow the instructions in the operation section to operate the mower. Vibration of the mower should be minimal at all times. After a 5 minute test run, the knife bolts should be retorqued and once again after the first few hours of operation.

If any parts of this assembly section, or any other section of this manual are not clearly understood you must contact your dealer or the address on the front of this manual for assistance!

ASSEMBLY

COMBO LIFT DRAFT BEAM INSTALLATION

Install ½" O-ring breather into butt port of inboard cylinder. Install fittings in the rod end of the cylinder according to the diagram in the commons section. These fittings should be positioned to face the butt end of the cylinder.

Next turn the clevis onto the rod of the cylinder until it is tight against the shoulder and lock into place with locking bolt on clevis.

The inboard cylinder can now be installed into the main frame mast with the pin, flat-washers and R-clips as shown below. Use teflon tape on all fitting and hose connections.

Install all fittings in the outboard cylinder and adjust to point towards the butt end of the cylinder. Attach the hoses as specified in the parts book. Slide the cylinder into the draft beam from the outside of the draft beam and attach cylinder to the draft beam with clevis pin and R-clips.

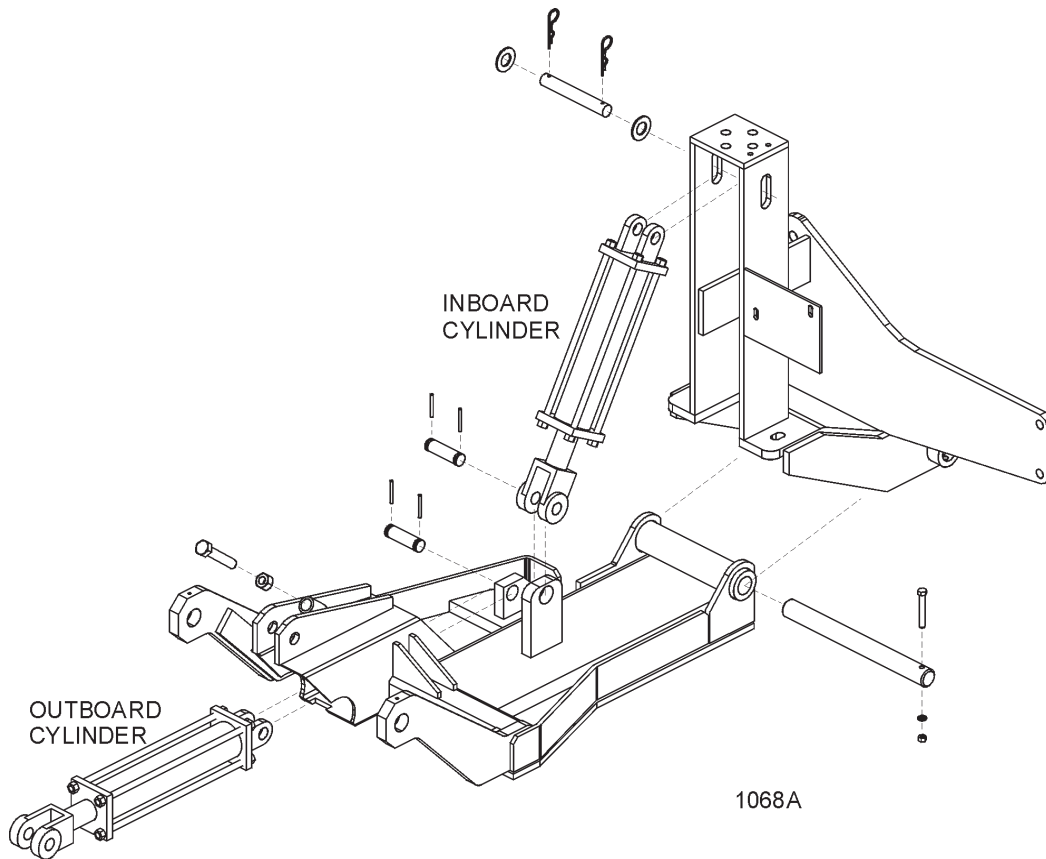

DRAFT BEAM MOUNTING

Pull the inboard cylinder piston rod down to the extreme extended position. Slide the draft beam under the cylinder, and align clevis hole with draft beam hole nearest to the tractor. Install pin and secure with R-clips.

Using inboard cylinder as a pivot point, slide draft beam under tractor and install draft beam pin. Align hole in draft beam pin with holes in main frame boss and install cap-screw, lock-washer and hex nut.

ASSEMBLY

DECK MOUNTING

Check that all grease zerks have been installed in the draft beams pivot arm, left linkage arm, right linkage arm, and cylinder mounting ears.

Using a clevis pin and roll pins, connect the pivot arm to clevis on draft beam.

NOTE: Make sure the longer distance between the cutout and the end of the pivot arm is closest to the draft beam pivot ears on the center tube as shown in the diagram below. Also make sure the cutout on the pivot arm faces into tube of draft beam.

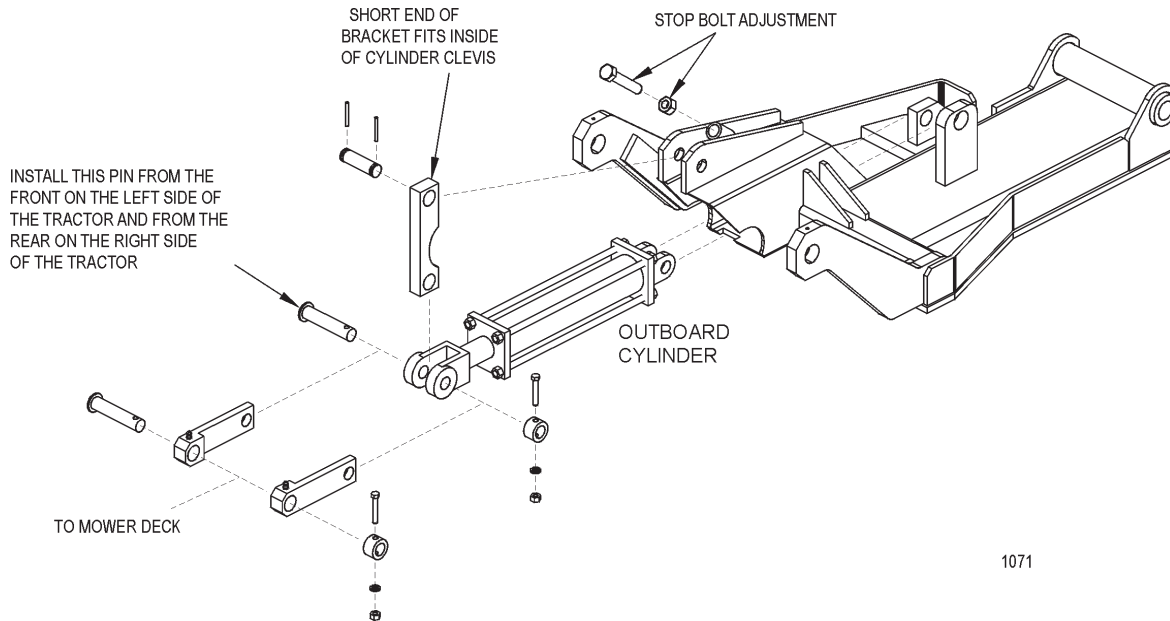

1071

Slide other end of pivot arm with short distance between the cut-out and the end of the pivot arm, into the cylinder clevis. Next, line up the holes of the left and right lift linkage arms outside of the cylinder clevis holes. Connect with linkage pin, shims (as required), boss, cap-screw, lock-washer and hex nut as shown.

To connect the bonnet to the draft beam, slide the extension arms of the draft beam between the mounting ears on the inner end of the bonnet. Line up the holes and secure with swivel pin, cap-screw, lock-washer, and hex nut (both sides). See parts book illustration.

Next, slide the left and right linkage arms up to the slotted ear on the side of the deck. Secure with linkage pin, shims, boss, cap-screw, lock-washer and hex nut. See illustration in parts section.

DECK / MOTOR FEEDLINE

Install the 1" hose with the 90 degree flange on the front side of the motor to the top of the solenoid valve. Secure to motor with flange kit, and install swivel fittings on the other end. Install the other 1" hose with the 60 degree flange on the back side of the motor to the bottom of the solenoid valve.

Install split hoses around hydraulic hoses where they contact sharp edges, or any other edges that may rub hoses.

ASSEMBLY

DECK / MOTOR FEEDLINE MOUNTING (cont.)

Be sure that all grease zerks are installed in the draft beam pin bosses. Grease all areas of the draft beam according to the instructions in the maintenance section. Re-check all fittings for tightness and be sure teflon tape has been used at all connections.

Fill hydraulic tank with fluid as recommended in the maintenance section. **BE SURE TO OPEN THE BALL VALVES.** Start the tractor and operate the inboard cylinder through the entire stroke and the outboard cylinder through the bottom $\frac{3}{4}$ stroke repeatedly to clear the lines of air. **DO NOT run outboard cylinder out to full stroke until stop bolt has been adjusted!**

Check for oil leaks at all fittings and connections using a piece of paper or cardboard. If a leak is found, you must shut down the tractor and set the cutter head on the ground. Before attempting to fix the leak, you must actuate the lift valve handles several times to relieve any pressure in the lines. **DO NOT USE HANDS TO CHECK FOR FLUID LEAKS!**

Raise the tree point hitch and check the tractor internal hydraulics, fill to proper level if needed.

CONTINUOUS DUTY SOLENOID SWITCH

Mount the solenoid switch, drill holes to match, and 30 AMP breaker mounting tab, mount in dry and well protected area. Secure with $\frac{3}{8}$ " x 1" capscrews, lockwashers, and hex nuts.

- A.) RED 6 GA. wire from terminal (D) to +12 volt battery post on starter solenoid.
- B.) RED 14 GA. wire from terminal (C) to +12 terminal on fuel pump.
- C.) GREEN 14 GA. wire from terminal (B) to negative ground.
- D.) RED 8 GA. wire from terminal (A) to 30 AMP breaker.
- E.) RED 14 GA. wire from terminal (A) to double switch box.
- F.) RED 14 GA. wire from terminal (A) to temperature gauge. (optional)
- G.) RED 8 GA. wire from breaker to reverser switch terminal (2).
- H.) RED 8 GA. wire from terminal (1) to +12 volt terminal on cooler fan.
- I.) BLACK 8 GA. wire from terminal (3) to ground on cooler fan.
- J.) BLACK 8 GA. wire form terminal (4) to control panel ground.

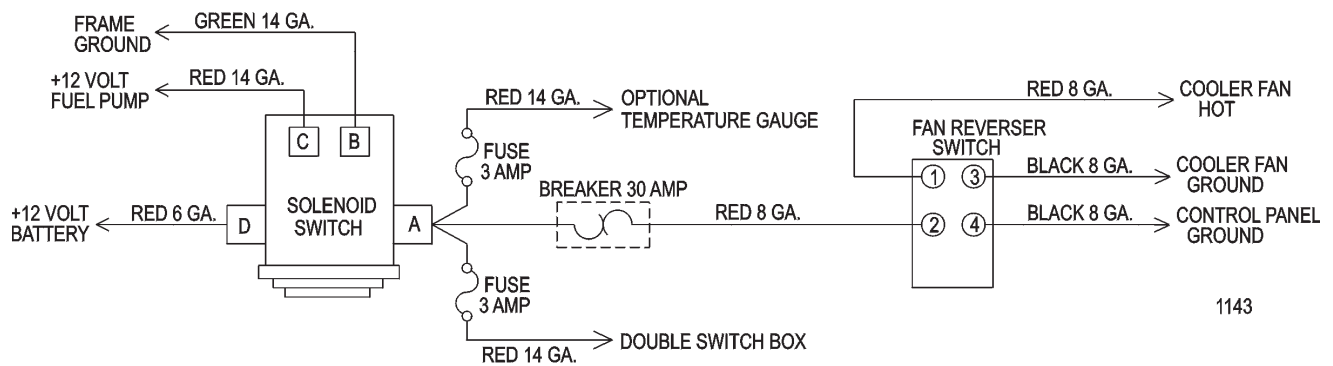

ASSEMBLY

STOP BOLT ADJUSTMENT

Extend the outboard cylinder all the way out. Adjust the stop adjustment bolt (located on the top of the draft beam) out until it is up against the bonnet. Lock the bolt down with the $\frac{3}{4}$ " hex nut.

NOTE: When the outboard cylinder is fully extended, the bonnet or deck should either be up against the stop or if travel locks are installed, it should be up against the travel lock. It may be necessary to use either external or internal slugs on the cylinder to get the correct stroke. If the cutter head is against the stop and the cylinder has stroke remaining, serious damage will occur.

Proceed to final preparation for operation instructions on the next page.

FINAL PREPARATION FOR OPERATION

Place operators safety and operation decals on the steering column and side counsel where they are clearly visible to the operator. These decals should be understood by each operator of the machine in conjunction with the safety and operation section of this book. The decals are to remain in good condition as a reminder to the operator, and should be replaced if damaged.

Double check that all pivot points have been greased. Secure all hoses together with zip ties and wrap with split hose sections where friction may occur on the hose.

WARNING!



BEFORE starting or operating the tractor you must read and understand the safety and operation sections of this manual completely.

Before operating the mower, the cutter head and draft beam should be slowly moved throughout the full range of motion. Watch for any condition that would cause pinching or excess stress on the hoses. The steering and front axle travel should also be carefully moved through their full range of motion. If any condition occurs in which the hoses contact the tires, the steering and / or front axle travel may need to be limited as described in the tractor operators manual. This should also be done if the tires rub, or are extremely close to any other part of the mower such as the hydraulic tank or draft beam. This may include adding shims, or adjusting stop bolts in the tractor front to solve the problem. While checking motion, you should also check that the control circuits are connected according to the operators decal for the valve handles.

MOWER TESTING

Take the tractor to a place free of loose objects on the ground. Operate the cylinders through their full range of motion again, to clear the lines of air. Follow the instructions in the operation section to operate the mower. Vibration of the mower should be minimal at all times. After a 5 minute test run, the knife bolts should be retorqued and once again after the first few hours of operation.

If any parts of this assembly section, or any other section of this manual are not clearly understood you must contact your dealer or the address on the front of this manual for assistance!

ASSEMBLY

OPERATION

**OPERATION
SECTION**

OPERATION

Safety is of primary importance to the owner / operator and to the manufacturer. The first section of this manual includes a list of Safety Messages, that, if followed, will help protect the operator and bystanders from injury or death. Many of the messages will be repeated throughout the manual. The owner / operator / dealer should know these Safety Messages before assembly and be aware of the hazards of operating this mower during assembly, use, and maintenance.

The **Safety Alert Symbol** combined with a signal word, as seen below, is intended to warn the owner / operator of impending hazards and the degree of injury possible during operation.

DANGER!



Indicates an imminently hazardous situation that, if not avoided, WILL result in DEATH OR VERY SERIOUS INJURY.

WARNING!



Indicates an imminently hazardous situation that, if not avoided, COULD result in DEATH OR SERIOUS INJURY.

CAUTION!



Indicates an imminently hazardous situation that, if not avoided, MAY result in MINOR INJURY.

IMPORTANT!

Identifies special instructions or procedures that, if not strictly observed, could result in damage to, or destruction of the machine, attachments or the environment.

NOTE: *Identifies points of particular interest for more efficient or convenient operation or repair.* (SG-1)

CAUTION!



Before any operation of tractor and mower, the user should read and understand the safety and operating instructions for both the tractor and the mower. The user should also be familiar with the location and functions of the units instruments and controls. Being familiar with the machine and its controls will increase efficiency and reduce possibility of serious injury or damage to the unit. The operator should work slowly and carefully until he feels comfortable with the machine. Speed and skill will be attained much easier if the necessary time is spent to familiarize yourself with the machine and its operations.

Since tractor makes and models vary, we recommend reading and following the operators manual provided by the manufacturer pertaining to your particular unit.

OPERATION



STARTING TRACTOR AND MOWER



Check the operators manual received from the tractor manufacturer, for their recommendation and procedures pertaining to your particular make and model.

WARNING!



When rotating parts are in motion, serious injury may occur if caution is not used or danger is not recognized. Never allow bystanders within **300 feet** of the machine when mower is in operation.



Be sure the ball valves on the mower hydraulic tank are **OPEN** before starting the tractor. Serious damage to the hydraulic system can occur if the valves are not open.

WARNING!



Check to make sure mower switch is in the “**OFF**” position. The unit is designed not to start if the switch is in the “on” position. If tractor starts with switch on, turn off tractor and contact your local Tiger dealership for assistance.

Start the tractor and allow the instruments to stabilize. Without starting the mower, practice positioning the boom and deck. Remember, speed and skill will be attained easier if the necessary time is spent familiarizing yourself with the machine and its operations. When you feel comfortable at controlling the position of the mower, return the mower to the travel position, and transport the mower to the desired mowing location.

If mowing for the first time with a Tiger Boom Mower, we recommend choosing a ditch or area relatively flat with a minimum of sign posts, guard rails, etc. As always, you should inspect the area for other objects that can cause potential hazards.

The Mower Control switch turns the mower “ON” and “OFF”. This switch is to be in the “OFF” position to start the tractor. The tractor will not start with the switch in the “ON” position.

WARNING!



If tractor starts with switch on, turn off tractor and contact your local Tiger dealership for assistance.

OPERATION

CONTROL LOCATION AND FUNCTIONS

The side mower height is controlled with a two or three spool valve and is coordinated as shown below. The optional three spool valve allows for the operation of a rear rotary mower or side ditcher. If the unit is equipped with a three spool valve, do not operate the third spool handle unless a rear rotary or ditcher is mounted.

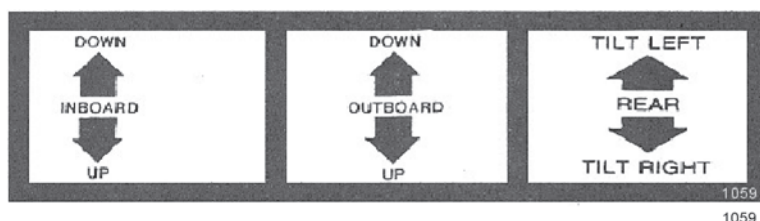

The rear mower height is controlled with the 3-point hitch control lever. Follow the instructions for this control in the tractor operators manual. The tilt of the rear mower is controlled with the third spool if the lift valve and is coordinated as shown above.

The side and rear mower positions may optionally be controlled with the tractor's remote hydraulic connections or a combination of lift valve and remote hydraulics. If so, determine which position of the side or rear mower is to be controlled by each remote lever.

The side mower ON / OFF switch is located in a switch box mounted to the valve stand or cable controls for non-cab and cab units respectively. If operating a rear mower, the ON / OFF switch is located in the switch box with a side mower switch.

This machine may be equipped with an auxiliary oil temperature gauge, an amp gauge or oil pressure gauge. If oil temperature reaches 200 degrees Fahrenheit, stop mowers and see trouble shooting section for possible causes. Keep an eye on all gauges for indication of problems.

MOWER OPERATION

WARNING!



When rotating parts are in motion, serious injury may occur if caution is not used or danger is not recognized. Never allow bystanders within **300 feet** of the machine when in operation. Extreme care should be taken when operating near loose objects – such as gravel, rocks and debris. These conditions should be avoided.

The rotating parts in this machine have been designed and tested for rugged use. However, they could fail upon impact with heavy solid objects – such as steel guard rails, concrete abutments, etc., causing them to be thrown at a very high velocity. Never allow cutter head to contact such objects. Inspecting the cutting area for such objects prior to mowing can help eliminate these potential hazards.

OPERATION

Once on location, lower the mower deck slightly above the material to be cut, so the mower does not have to start under a load. Bring the R.P.M. of the tractor up to 1200 and engage the side mower. If a rear mower is being used, allow the R.P.M. to return to 1200 before engaging the rear mower.

The rotary mower deck should always be carried rather than dragged on the skid shoes when mowing on the ground. Dragging the rotary mower heads causes an extreme side load on the tractor resulting in premature tire wear. It also causes excessive horsepower consumption and drastically decreases blade life. Dragging the rear mower can also cause damage to the road. Once the necessary skill is attained at controlling the height and position of the side rotary mower, it will be easy to carry the mower head(s) and do a proficient job of cutting.

When cutting tall shrubs or small trees (maximum recommended size of material to be cut is 2" diameter) begin each pass at the top of the material and work down with each consecutive pass. Use a low speed to allow the cutting blades time to mulch as well as cut the foliage. When the initial pass has been made, disengage the mower and return the mower to the travel position. Return to the starting point and make next pass, etc.

CAUTION!



When using the rotary cutting head for trimming trees and shrubs, let the mower saw into them. Do not lower the mower head down directly onto a tree or stump. The mower blades are designed to cut with the end, and misuse can cause damage to the blade and a hazardous situation for the operator.

To ensure a clean cut, engine speed should be maintained at approximately 1800 – 2200 R.P.M. If the tractor slows to less than 1800 R.P.M., shift to the next lower gear. **DO NOT** ride the clutch, this will cause premature clutch failure. **The engine should not be operated at any time at more than 2400 R.P.M. on the tractor tachometer.**

DO NOT use excessive force when positioning cutting head into heavy branches or small stumps (2" diameter). Damage to the unit may result. It is best to let the cutter head "eat away" slowly at heavy cutting jobs.

The mower will operate more efficiently in tougher conditions and with less power if the knives are kept sharp. If the mower begins to vibrate, stop the tractor, check for wire wrapped in the spindle or damaged knives. When replacing knives, replace all knives with new knives to ensure proper balance so the mower will not vibrate. Severe vibration will result, if knives with unequal wear are used. Follow the instructions in the maintenance section closely when replacing knife blades.

WARNING!



If bystanders approach within 300 feet while mower is in operation turn mower switch "OFF" immediately! After shutdown, never leave the tractor or allow bystanders to approach within **300 FEET** of the unit until all motion stops completely.

OPERATION

When encountering a very severe condition which causes the tractor to stall, disengage mower, start tractor, raise the mower from the cut. Shut tractor off and inspect the mower, blades and disk for damage before engaging mower again.

If the blades jam or stop, disengage the clutch and raise the head slightly or back the tractor up. Normally, this will clear the cutter head. If not, shut off the mower(s), raise the cutter heads, turn off the tractor and set the parking brake. After all motion stops completely, leave the tractor and clear the cutting heads manually.

After the first day of operation, all bolts should be checked and tightened securely. This should be done periodically to ensure the bolts do not become loose and cause damage to the tractor or mower, or injury to the operator.

REVERSE FAN OPERATION

Normal operation - Operating position is with fan switch ON (upper position)

Reversing fan to clear chaff -Reverser fan switch is to be used as follows as necessary for clearing chaff from cooling fins:

1. Normal operating position is with fan switch ON (upper position)
2. Turn fan switch OFF (center position), wait at least 3 seconds
3. Push switch DOWN to reverse,
4. Allow chaff to clear
5. Turn fan switch OFF (center position), wait at least 3 seconds
6. Turn fan switch to ON (upper position)

OPERATION

TRANSPORTING MOWER

Transporting under the units own power:

When transporting between job sites or between cutting passes, the following procedure should be followed: Shut off the power to the cutting head(s) and allow all motion to come to a complete stop. Raise the draft beam to it's highest position. Raise the side mower until the deck stops against the draft beam. Raise the rear mower with the 3-point hitch control lever. The unit is now in position for self transportation.

Transporting unit by flatbed trailer:

Most tractors with a side mounted mower head attached will be over legal transporting width (102" wide). For this reason, one of the following procedures must be followed.

1: Transporting with side mower attached: Use a loading dock or ramp to load tractor onto the trailer. Center the tractor with the mowers attached between the sides of the trailer. Make sure the draft beam and head are fully raised and secured. Lower the rear mower onto the trailer. Secure the tractor and rear mower to the trailer with chains. Obtain proper over-width permits and mark the vehicle and mower as over-width as required be law. Check the tractor operators manual for any tractor requirements to transport by flatbed trailer.

2: Transporting with side mower removed: Park the tractor and turn the engine off. Remove the key to avoid accidental starting. Close ball valves on the hydraulic reservoir. To avoid contaminating the hydraulic system, make sure all fittings on the side mower motor and solenoid control valve are clean. Disconnect the motor pressure hose at the solenoid valve and the motor return hose at the motor. See diagram below.

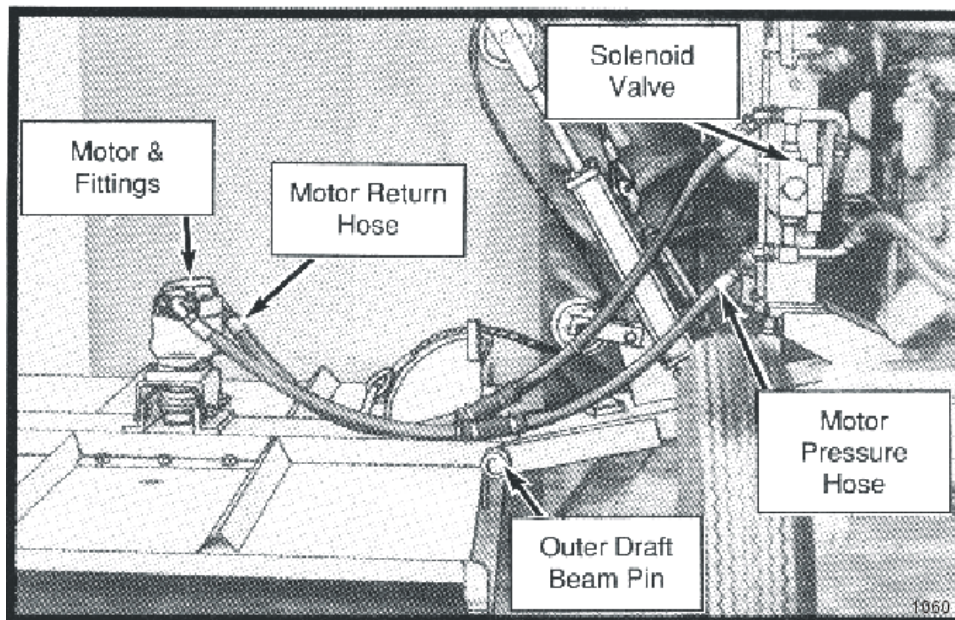

OPERATION

Next, switch the hose ends and reconnect to form two separate closed loops, see diagram below. Disconnect the lift cable from the head and secure the loose end back onto the cable with the cable clevis. Remove the keeper bolt and draft beam outer pivot pin. Separate the mower head from the tractor. Now reinstall the pivot pin and keeper bolts into the draft beam to prevent loss. **OPEN THE BALL VALVES ON THE HYDRAULIC RESERVOIR BEFORE STARTING TRACTOR AGAIN!** Serious damage will be caused if tractor is started with the ball valves closed.

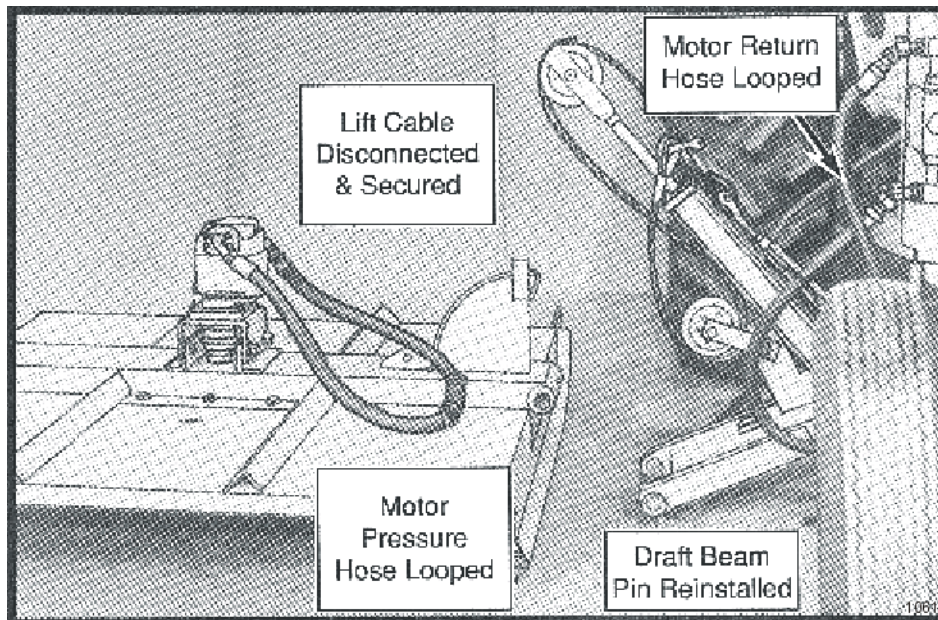

Use a loading dock or ramps to load the tractor onto the trailer, centering the tractor between the sides of the trailer. Make sure the tractor (and rear mower) and trailer are within legal transporting width. Lower the rear mower onto the trailer and set the loose hide mower on the trailer. Secure the tractor and mowers to the trailer with chains. Check the tractor operators manual for any requirements to transport be flatbed trailer. Reverse this procedure to unload and remount the mowers after transporting. Be sure all pins are secure, all connections are tight and any lost fluid is replaced before using mowers. Use teflon tape when connecting all fittings.

CAUTION!



If any part of this operating section, or any other section of this manual is not completely understood, contact your Tiger dealer or the address on the cover of this manual for assistance!

OPERATION

INSPECTION SHEETS

OPERATION

Rotary Mower PRE-OPERATION Inspection



Tractor ID# _____ Make _____

Date: _____ Shift _____

WARNING!



Before conducting the inspection, make sure the Tractor engine is off, all rotation has stop and the tractor is in the Park with the parking brake engaged. The Mower head is resting on the ground (or is securely blocked up and supported) and all hydraulic pressure has been relieved.

| Item | Condition at Start of Shift | Specific Comments if not O.K. |
|--|-----------------------------|-------------------------------|
| The Operator's Manual is in the Canister on the mower | | |
| All Safety Decals are in place and legible | | |
| The Mounting frame bolts are in place and tight | | |
| There are no cracks in Draftbeam or Yolk | | |
| The Draftbeam/Yolk connection bolts & pins are tight | | |
| There are no cracks or holes in mower deck | | |
| The Hydraulic motor mounting bolts are tight | | |
| The mower head spindle housing is tight and lubricated | | |
| There mower deck is clear of cut grass and debris | | |
| The Skid shoes are in good condition & tight | | |
| Chain Guards/Deflectors are in place & in good condition | | |
| Blade carrier retaining nut is tight | | |
| Blades are not chipped, cracked or bent | | |
| Blade bolts are tight | | |
| Transport locks are in good condition | | |
| There are no leaking or damaged hoses | | |
| There is no evidence of Hydraulic leaks | | |
| The Hydraulic Oil level is full | | |
| The Hydraulic Cylinders pins are tight | | |
| The Hydraulic Pump hose connections are tight | | |
| The Hydraulic Valve hose connections are tight | | |
| The Hydraulic Valve controls function properly | | |
| Wheel lug nuts are tight | | |

Operators Signature: _____

DO NOT OPERATE an UNSAFE TRACTOR or MOWER

OPERATION

TRACTOR PRE-OPERATION Inspection



Tractor ID# _____ Make _____

Date: _____ Shift _____

WARNING!



Before conducting the inspection, make sure the Tractor engine is off, all rotation has stop and the tractor is in the Park with the parking brake engaged. The Mower head is resting on the ground (or is securely blocked up and supported) and all hydraulic pressure has been relieved.

| Item | Condition at Start of Shift | Specific Comments if not O.K. |
|--|-----------------------------|-------------------------------|
| The Flashing lights function properly | | |
| The SMV Sign is clean and visible | | |
| The Tires are in good condition with proper pressure | | |
| The Wheel Lug bolts are tight | | |
| The tractor Brakes are in good condition | | |
| The Steering linkage is in good condition | | |
| There are no visible Oil Leaks | | |
| The Hydraulic controls function properly | | |
| The ROPS or ROPS Cab is in good condition | | |
| The Seatbelt is in place and in good condition | | |
| The 3-Point Hitch is in good condition | | |
| The Drawbar pins are securely in place | | |
| The PTO Master Shield is in place | | |
| The Engine Oil level is full | | |
| The Brake Fluid level is full | | |
| The Power Steering Fluid Level is full | | |
| The Fuel level is adequate | | |
| The Engine Coolant Fluid level is full | | |
| The Radiator is free of debris | | |
| The Air filter is in good condition | | |

Operators Signature: _____

DO NOT OPERATE an UNSAFE TRACTOR or MOWER

OPERATION

FRONT END LOADER PRE-OPERATION Inspection



Mower ID# _____ Make _____

Date: _____ Shift _____

WARNING!



Before conducting the inspection, make sure the Tractor engine is off, all rotation has stop and the tractor is in the Park with the parking brake engaged. The Loader is resting on the ground (or is securely blocked up and supported) and all hydraulic pressure has been relieved.

| Item | Condition at Start of Shift | Specific Comments if not O.K. |
|--|-----------------------------|-------------------------------|
| The Operator's Manual is in the Canister on the mower | | |
| All Safety Decals are in place and legible | | |
| The Mounting frame bolts are in place and tight | | |
| There are no cracks in Draftbeam or Yolk | | |
| The Draftbeam/Yolk connection bolts & pins are tight | | |
| There are no cracks or holes in mower deck | | |
| The Hydraulic motor mounting bolts are tight | | |
| The mower head spindle housing is tight and lubricated | | |
| There mower deck is clear of cut grass and debris | | |
| The Skid shoes are in good condition & tight | | |
| Chain Guards/Deflectors are in place & in good condition | | |
| Blade carrier retaining nut is tight | | |
| Blades are not chipped, cracked or bent | | |
| Blade bolts are tight | | |
| Transport locks are in good condition | | |
| There are no leaking or damaged hoses | | |
| There is no evidence of Hydraulic leaks | | |
| The Hydraulic Oil level is full | | |
| The Hydraulic Cylinders pins are tight | | |
| The Hydraulic Pump hose connections are tight | | |
| The Hydraulic Valve hose connections are tight | | |
| The Hydraulic Valve controls function properly | | |
| Wheel lug nuts are tight | | |

Operators Signature: _____

DO NOT OPERATE an UNSAFE TRACTOR or FRONT END LOADER

OPERATION

TRACTOR PRE-OPERATION Inspection



Tractor ID# _____ Make _____

Date: _____ Shift _____

WARNING!



Before conducting the inspection, make sure the Tractor engine is off, all rotation has stop and the tractor is in the Park with the parking brake engaged. The Loader is resting on the ground (or is securely blocked up and supported) and all hydraulic pressure has been relieved.

| Item | Condition at Start of Shift | Specific Comments if not O.K. |
|--|-----------------------------|-------------------------------|
| The Flashing lights function properly | | |
| The SMV Sign is clean and visible | | |
| The Tires are in good condition with proper pressure | | |
| The Wheel Lug bolts are tight | | |
| The Tractor Brakes are in good condition | | |
| The Steering linkage is in good condition | | |
| There are no visible Oil Leaks | | |
| The Hydraulic controls function properly | | |
| The ROPS or ROPS Cab is in good condition | | |
| The Seatbelt is in place and in good condition | | |
| The PTO Master Shield is in place | | |
| The Engine Oil level is full | | |
| The Brake Fluid level is full | | |
| The Power Steering Fluid Level is full | | |
| The Fuel level is adequate | | |
| The Engine Coolant Fluid level is full | | |
| The Radiator is free of debris | | |
| The Air filter is in good condition | | |

Operators Signature: _____

**DO NOT OPERATE an UNSAFE TRACTOR or FRONT END
LOADER**

OPERATION

MAINTENANCE

MAINTENANCE SECTION

MAINTENANCE

Tiger Mowers are designed for high performance and rugged durability, yet with simplified maintenance. The purpose of this section of the manual is to help the operator in the regular servicing of the mower. Regular maintenance at the intervals mentioned will result in the maximum efficiency and long life of the Tiger Mower.

When you purchase a Tiger Mower you also acquire another valuable asset, Tiger's parts organization. Our rapid and efficient service has guaranteed the customer satisfaction for many years. Tiger parts keep up with the demands for efficiency, safety and endurance expected of the Tiger Mower.

MAINTENANCE PRECAUTIONS

Be sure end of grease gun and zerks are clean before using. Debris injected into bearings, etc. with grease will cause immediate damage.

- DO NOT use a power grease gun to lubricate bearings. These require very small and exact amounts of lubrication. Refer to the detailed maintenance section for specific lubrication instructions. Do Not over-grease bearings.
- Lexan windows should be washed with mild soap or detergent and luke warm water, using a soft clean sponge or **soft cloth**. DO NOT use abrasive or alkaline cleaners or metal scrapers on lexan windows!
- Be alert to maintenance indicators such as the in-tank filter pressure gauge, hydraulic reservoir sight gauge, etc. Take the required action to correct any problems immediately.
- Release of energy from pressurized systems may cause inadvertent actuation of cylinders, or sudden release of compressed springs. Before disconnecting any hoses relieve pressure by shutting tractor off, setting cutter on ground and actuating lift valve handles.

WARNING!



DO NOT use hands to check for suspected leaks in hydraulic hoses! Hydraulic fluid escaping under pressure can have sufficient force to penetrate skin and cause serious injury. If fluid is injected into skin, it must be surgically removed within a few hours or gangrene may result. Use a small piece of wood or cardboard, not hands, to search for pin hose leaks. Be sure all pressure is relieved whenever disconnecting lines. Be sure all connections are tight and hoses and lines are not damaged before applying pressure.

BREAK IN PERIOD

In addition to following the break in instructions for your particular tractor, the in-tank hydraulic fluid filter should be replaced after the first 50 hours of service. Thereafter the filter should be replaced every 500 hours, or yearly, whichever ever comes first.

Re-torque wheel lugs after first five hours of operation and periodically thereafter. See torque specifications listed in the tractor's service manual for your particular model. **Wheel lugs must always be re-torqued whenever a wheel is removed and reinstalled.**

MAINTENANCE

REGULAR MAINTENANCE

The intervals at which regular servicing should be done are based on hours of operation. Use the tractors hour meter to determine when regular servicing is required.



This symbol indicates a point that needs to be greased at an interval noted in the section below. Refer to the Detailed Maintenance section for further instructions on greasing. Copy and use the Daily Maintenance sheet located at the end of this section.

DAILY OR EVERY 8 HOURS

| ITEM | SERVICE | COMMENTS |
|--|-----------------------|--|
| Drive Shaft Yoke, U-Joint & Stub Shaft | Grease | Grease as instructed in detailed maint. section |
| Pump Drive Shaft Coupler | Check and Lube | Insure drive shaft end play |
| Crankshaft Adapter | Check rubber grommets | Replace grommets if damaged or missing |
| Pivot Points | Lubricate | Inject grease until it appears at ends |
| Hydraulic Fittings | Check for leaks | Tighten when needed. Do Not use hands to check for leaks, see maint. Precautions |
| Knives | Check | Inspect for missing or damaged knives, change or sharpen as needed |
| Spindle mounting bolts (spindle to deck) | Check | 3/4" x 2" torque to 331 ft. lbs. |
| Knife mounting bolts (knife to disk) | Check | Pre-lubricate threads, then torque to 800 ft. lbs. |
| Disk mounting bolts (disk to spindle) | Check | 5/8" x 1-3/4" bolt torque to 204 dry or 184 oiled ft. lbs. |
| Belts | Check / Adjust | Check if broken, tighten as required |
| Main Frame and Deck | Check | Retorque bolts to torque specifications in this section |
| Hydraulic Fluid Level | Check | Add if required per fluid recommendations |

MAINTENANCE

WEEKLY OR EVERY 50 HOURS

| ITEM | SERVICE | COMMENTS |
|---|---------|--|
| In Tank Hyd. Fluid Filter (10 micron filter) | Change | Change after first 50 hours only, then every 500 hours or yearly |
| In-Line High Pressure Filter (10 micron filter) | Change | Change after first 50 hours only, then every 500 hours or yearly |

MONTHLY OR EVERY 150 HOURS

| | | |
|-----------------------|-------------------------|--------------------------------------|
| Hydraulic Fluid Level | Check | Add as needed |
| Hyd. Tank Breather | Clean / Check / Replace | Clean or replace Element as required |
| Rear Tire Type | Max P.S.I. | |
| 480/80R38 | 29 | |
| 18.4-34 | 26 | |
| 18.4-38 | 26 | |

YEARLY OR EVERY 500 HOURS

| | | |
|--|--------|--|
| Spindle Grease | Change | |
| Motor to Spindle Spline | Change | |
| Hyd. Tank Fluid | Change | |
| In Tank Hyd. Fluid Filter (10 micron filter) | Change | |
| In-Line HP Filter (10 micron filter) | Change | or Change when indicated by restriction indicator. |
| Hyd. Tank Breather | Change | |

TROUBLESHOOTING

| SYMPTOMS | CAUSE | REMEDY |
|----------------------------|--|--|
| Vibration | 1. Loose bolts 2. Cutter assembly Unbalanced | 1. Check all bolts and tighten to torque specs. in this section. 2a. Check for damaged blades, disc. or cutter shaft. Replace if needed. 2b. Check for wire, rope, etc. entangled in cutter assembly |
| Mower will not lift | 1. Hyd. Fluid low 2. Leaks in line 3. Faulty relief valve 4. Kinked / blocked 5. Faulty cylinder | 1. Check and refill Hyd. Fluid. 2. Tighten or replace fittings and hoses 3. Check pressure in line. Line pressure in Control Valve should be at least 2500 P.S.I. 4. Clean or replace lines 5. Inspect, repair or replace cylinder |

MAINTENANCE

| SYMPTOMS | CAUSE | REMEDY |
|---|---|---|
| Oil Temperature rises above 200 deg. F | <ol style="list-style-type: none"> 1. Low oil level 2. Kinked or blocked hoses 3. Worn pump/motor | <ol style="list-style-type: none"> 1. Bring oil to proper level 2. Inspect, Repair, or Replace 3. Disable and repair |
| Mower will not start or run | <ol style="list-style-type: none"> 1. Blown fuse 2. Ball valves closed 3. Low oil level 4. Line leak 5. Electronic solenoid faulty | <ol style="list-style-type: none"> 1. Check fuse between mower switch and ignition / replace 2. Make sure valves are open 3. Check Hyd. tank and fill 4. Check all fittings and lines. 5a. Without the tractor running, turn the mower switch to on. A low audible click should be heard if the solenoid is engaging the solenoid spool. If click is not heard, leave switch in on position and with a screwdriver or other steel object, touch the small nut on the end of the solenoid. If the metallic object is not attracted to the nut, check the fuse and wiring for an open circuit. If the object is attracted but no "click" is heard, replace the solenoid. 5b. Remove the four bolts holding the small block to the main block. Lift and remove small block being careful not to damage O-rings / filter. Clean filter and re-install. 5c. Remove large nut on side of large valve block. Remove spring, and use needle nose vise grip to pull spool from block. Check block and spool for contaminates and scratches. Clean parts or replace if scratched. |
| Motor runs but | <ol style="list-style-type: none"> 1. Belts 2. Tensioner | <ol style="list-style-type: none"> 1. Inspect belts and pulleys. Replace belts and repair as needed. 2. Adjust tensioner nut until flat washer is flush with top of guide. |
| Motor turns slowly or not at all. | <ol style="list-style-type: none"> 1. Contaminants restricting spool 2. Suction lines 3. Low oil level | <ol style="list-style-type: none"> 1. Remove large nut on side of large valve block. Remove spring, and use movement in needle nose vise grip to pull spool valve body from block. Check block and spool for contaminates and scratches. Clean parts or replace if scratched. 2. Check for kinkes or obstruction in obstructed suction hose 3. Check Hyd. tank level and fill |
| Pump will not work | <ol style="list-style-type: none"> 1. Excessive wear on internal parts | <ol style="list-style-type: none"> 1. Disassemble and repair. |

MAINTENANCE





Motor will not work 1. Excessive wear on internal parts 1. Disassemble and repair.

NOTE: If flow meter is available, check pressure and flow volume for all suspected hydraulic problems.





If the solution to your problem cannot be found in this section, call the Technical Service representative at the number shown on the front cover of this manual.

MAINTENANCE

TORQUE SPECIFICATIONS

| Torque for Standard Fasteners | | | | | | | | | | | | | |
|-------------------------------|------------------|---|------------------------|-----------------------|---|------------------------|-----------------------|---|------------------------|-----------------------|---|------------------------|-----------------------|
| Nominal Dia. (in.) | threads per inch |  Grade 2 | | |  Grade 5 | | |  Grade 8 | | |  Grade 9 | | |
| | | Tightening Torque | | | Tightening Torque | | | Tightening Torque | | | Tightening Torque | | |
| | | Lubed K = 0.15 | Dry Plated K = 0.17 | Dry plain K = 0.20 | Lubed K = 0.15 | Dry Plated K = 0.17 | Dry plain K = 0.20 | Lubed K = 0.15 | Dry Plated K = 0.17 | Dry plain K = 0.20 | Lubed K = 0.15 | Dry Plated K = 0.17 | Dry plain K = 0.20 |
| Unified Coarse Thread Series | | | | | | | | | | | | | |
| 1/4 | 20 | 49 in-lbs | 59 in-lbs | 66 in-lbs | 76 in-lbs | 86 in-lbs | 101 in-lbs | 107 in-lbs | 122 in-lbs | 143 in-lbs | 126 in-lbs | 143 in-lbs | 168 in-lbs |
| 5/16 | 18 | 101 | 122 | 135 | 157 | 178 | 209 | 221 | 251 | 295 | 259 | 294 | 346 |
| 3/8 | 16 | 15 ft-lbs | 18 ft-lbs | 20 ft-lbs | 23 ft-lbs | 26 ft-lbs | 31 ft-lbs | 33 ft-lbs | 37 ft-lbs | 44 ft-lbs | 38 ft-lbs | 43 ft-lbs | 51 ft-lbs |
| 7/16 | 14 | 24 | 29 | 32 | 37 | 42 | 49 | 52 | 59 | 70 | 61 | 70 | 82 |
| 1/2 | 13 | 37 | 44 | 49 | 57 | 64 | 75 | 80 | 90 | 106 | 94 | 106 | 125 |
| 9/16 | 12 | 53 | 63 | 70 | 82 | 92 | 109 | 115 | 130 | 154 | 135 | 153 | 180 |
| 5/8 | 11 | 73 | 87 | 97 | 113 | 128 | 150 | 159 | 180 | 212 | 186 | 211 | 248 |
| 3/4 | 10 | 129 | 155 | 172 | 200 | 227 | 267 | 282 | 320 | 376 | 331 | 375 | 441 |
| 7/8 | 9 | 125 | 150 | 167 | 322 | 365 | 429 | 455 | 515 | 606 | 533 | 604 | 710 |
| 1 | 8 | 187 | 225 | 250 | 483 | 547 | 644 | 681 | 772 | 909 | 799 | 905 | 1065 |
| 1 1/8 | 7 | 266 | 319 | 354 | 596 | 675 | 794 | 866 | 1095 | 1288 | 1132 | 1283 | 1510 |
| 1 1/4 | 7 | 375 | 450 | 500 | 840 | 952 | 1121 | 1363 | 1545 | 1817 | 1597 | 1810 | 2130 |
| 1 1/2 | 6 | 652 | 783 | 869 | 1462 | 1657 | 1950 | 2371 | 2688 | 3162 | 2779 | 3150 | 3706 |
| Fine Thread Series | | | | | | | | | | | | | |
| 1/4 | 28 | 56 in-lbs | 68 in-lbs | 75 in-lbs | 87 in-lbs | 99 in-lbs | 116 in-lbs | 123 in-lbs | 139 in-lbs | 164 in-lbs | 144 in-lbs | 163 in-lbs | 192 in-lbs |
| 5/16 | 24 | 112 | 135 | 150 | 174 | 197 | 231 | 245 | 278 | 327 | 287 | 325 | 383 |
| 3/8 | 24 | 17 ft-lbs | 20 ft-lbs | 23 ft-lbs | 26 ft-lbs | 30 ft-lbs | 35 ft-lbs | 37 ft-lbs | 42 ft-lbs | 49 ft-lbs | 43 ft-lbs | 49 ft-lbs | 58 ft-lbs |
| 7/16 | 20 | 27 | 32 | 36 | 41 | 47 | 55 | 58 | 66 | 78 | 68 | 78 | 91 |
| 1/2 | 20 | 41 | 49 | 55 | 64 | 72 | 85 | 90 | 102 | 120 | 105 | 120 | 141 |
| 9/16 | 18 | 59 | 71 | 78 | 91 | 103 | 121 | 128 | 146 | 171 | 151 | 171 | 201 |
| 5/8 | 18 | 82 | 99 | 110 | 127 | 144 | 170 | 180 | 204 | 240 | 211 | 239 | 281 |
| 3/4 | 16 | 144 | 173 | 192 | 223 | 253 | 297 | 315 | 357 | 420 | 369 | 418 | 492 |
| 7/8 | 14 | 138 | 165 | 184 | 355 | 403 | 474 | 502 | 568 | 669 | 588 | 666 | 784 |
| 1 | 14 | 210 | 252 | 280 | 542 | 614 | 722 | 765 | 867 | 1020 | 896 | 1016 | 1195 |
| 1 1/8 | 12 | 298 | 357 | 397 | 668 | 757 | 890 | 1083 | 1227 | 1444 | 1269 | 1439 | 1693 |
| 1 1/4 | 12 | 415 | 498 | 553 | 930 | 1055 | 1241 | 1509 | 1710 | 2012 | 1768 | 2004 | 2358 |
| 1 1/2 | 12 | 734 | 880 | 978 | 1645 | 1865 | 2194 | 2668 | 3024 | 3557 | 3127 | 3544 | 4169 |

Torque values for 1/4 and 5/16-in series are in inch-pounds. All other torque values are in foot-pounds. K = 0.15 for "lubricated" conditions
 Torque values calculated from formula T=KDF, where K = 0.17 for zinc plated and dry conditions D = Nominal Diameter
 K = 0.20 for plain and dry conditions F = Clamp Load

| Torque-Tension Relationship for Metric Fasteners | | | | | | | | | | | | | |
|--|-------|---|------------------------|-----------------------|---|------------------------|-----------------------|---|------------------------|-----------------------|--|------------------------|-----------------------|
| Nominal Dia. (mm) | Pitch |  Class 4.6 | | |  Class 8.8 | | |  Class 10.9 | | |  Class 12.9 | | |
| | | Tightening Torque | | | Tightening Torque | | | Tightening Torque | | | Tightening Torque | | |
| | | Lubed K = 0.15 | Dry Plated K = 0.17 | Dry plain K = 0.20 | Lubed K = 0.15 | Dry Plated K = 0.17 | Dry plain K = 0.20 | Lubed K = 0.15 | Dry Plated K = 0.17 | Dry plain K = 0.20 | Lubed K = 0.15 | Dry Plated K = 0.17 | Dry plain K = 0.20 |
| 3 | 0.5 | 0.28 | 0.32 | 0.38 | 0.73 | 0.82 | 0.97 | 1.0 | 1.2 | 1.4 | 1.2 | 1.6 | |
| 3.5 | 0.6 | 0.44 | 0.50 | 0.59 | 1.1 | 1.3 | 1.5 | 1.6 | 1.9 | 2.2 | 1.9 | 2.5 | |
| 4 | 0.7 | 0.66 | 0.74 | 0.87 | 1.7 | 1.9 | 2.3 | 2.4 | 2.7 | 3.2 | 2.8 | 3.8 | |
| 5 | 0.8 | 1.3 | 1.5 | 1.8 | 3.4 | 3.9 | 4.5 | 4.9 | 5.5 | 6.5 | 5.7 | 7.6 | |
| 6 | 1 | 2.3 | 2.6 | 3.0 | 5.8 | 6.6 | 7.7 | 8.3 | 9.4 | 11 | 9.7 | 13 | |
| 6 | 1.25 | 2.1 | 2.3 | 2.7 | 5.3 | 6.0 | 7.0 | 7.6 | 8.6 | 10 | 8.8 | 12 | |
| 7 | 1 | 3.8 | 4.3 | 5.0 | 9.7 | 11 | 13 | 14 | 16 | 19 | 16 | 22 | |
| 8 | 1 | 5.9 | 6.6 | 7.8 | 15 | 17 | 20 | 22 | 24 | 29 | 25 | 34 | |
| 8 | 1.25 | 5.5 | 6.2 | 7.3 | 14 | 16 | 19 | 20 | 23 | 27 | 24 | 31 | |
| 10 | 1.25 | 11 | 13 | 15 | 29 | 33 | 39 | 42 | 48 | 56 | 49 | 66 | |
| 10 | 1.5 | 11 | 12 | 14 | 28 | 32 | 37 | 40 | 45 | 53 | 47 | 62 | |
| 12 | 1.25 | 21 | 23 | 28 | 53 | 60 | 71 | 76 | 86 | 101 | 89 | 119 | |
| 12 | 1.5 | 20 | 22 | 26 | 51 | 58 | 68 | 73 | 82 | 97 | 85 | 113 | |
| 12 | 1.75 | 19 | 21 | 25 | 49 | 55 | 65 | 70 | 79 | 93 | 81 | 108 | |
| 14 | 1.25 | 26 | 29 | 34 | 66 | 75 | 89 | 95 | 108 | 127 | 111 | 148 | |
| 14 | 1.5 | 28 | 32 | 37 | 72 | 82 | 96 | 103 | 117 | 138 | 121 | 161 | |
| 14 | 2 | 30 | 34 | 40 | 78 | 88 | 104 | 111 | 126 | 148 | 130 | 173 | |
| 16 | 1.5 | 50 | 57 | 67 | 129 | 146 | 171 | 184 | 208 | 245 | 215 | 287 | |
| 16 | 2 | 47 | 53 | 62 | 121 | 137 | 161 | 173 | 196 | 230 | 202 | 269 | |
| 18 | 1.5 | 73 | 82 | 97 | 187 | 212 | 249 | 268 | 303 | 357 | 313 | 417 | |
| 18 | 2.5 | 65 | 73 | 86 | 167 | 189 | 222 | 239 | 270 | 318 | 279 | 372 | |
| 20 | 2.5 | 91 | 104 | 122 | 236 | 267 | 314 | 337 | 382 | 449 | 394 | 525 | |

Clamp load calculated as 75% of the proof load for specified bolts. K = 0.15 for "lubricated" conditions D = Nominal Diameter
 All torque values are listed in foot-pounds K = 0.17 for zinc plated, dry conditions F = Clamp Load
 Torque values calculated from formula T=KDF, where K = 0.20 for plain and dry conditions

* These are intended to be general specifications. See tractor operators or service manual for exact specifications for your unit.

MAINTENANCE

LUBRICATION RECOMMENDATIONS

| Description | Application | General Specification | Recommended Mobil Lubricant |
|---|---------------|---|--|
| Tractor Hydraulics | Reservoir | JD-20C MF M1135,M1141 FNHM2C134D (FNH201) | Mobilfluid 424 |
| Mower Hydraulics | Reservoir | | |
| Cold Temperatures 0 F Start-Up | | ISO 46 Anti-Wear - Low Temp | Mobil DTE 15M |
| Normal Temperatures 10 F Start-Up | | JD-20C MF M1135,M1141 FNH M2C134D (FNH201) | Mobilfluid 424 |
| Normal Temperatures 15 F Start-Up | | ISO 46 Anti-Wear | Mobil DTE 25 |
| High Operating Temp. Above 90 F | | ISO 100 Anti-Wear | Mobil DTE 18M |
| Flail Rear Gearbox | Grease | PAO Synthetic Extreme Pressure Gear Lube | Mobil SHC 75W-90 Mobil 1 Synthetic Gear |
| Cutter Shaft & Ground Roller Shaft (Flail) | Grease Gun | Lithium-Complex Extreme Pressure NLGI 2 - ISO 320 | Mobilgrease CM-S |
| Drive Shaft Coupler (Flail and Rotary) | Grease Gun | Lithium-Complex Extreme Pressure NLGI2 - ISO 320 | Mobilgrease CM-S |
| Drive Shaft Yoke, U-Joint & Stub Shaft | Grease Gun | Lithium-Complex Extreme Pressure NLGI2 - ISO 320 | Mobilgrease CM-S |
| Boom Swivel Boom Cylinder Pivots (Rotary & Flail Boom) | Grease Gun | Lithium-Complex Extreme pressure NLGI2 - ISO 320 | Mobilgrease CM-S |
| Deck Boom Pivot & Deck Stop Adjustment (Rotary & Flail) | Grease Gun | Lithium-Complex Extreme pressure NLGI 2 - ISO 320 | Mobilgrease CM-S |
| Deck Spindle (Rotary) | Grease Gun | Tiger Spindle Lubricant part number 06540000 | Mobilith SHC 220 |

MAINTENANCE

POLYCARBONATE CARE & MAINTENANCE

The proprietary UV and Abrasion Resistant surface coating on SHIELDS® SUPERCOATED™ polycarbonate significantly improves performance. Periodic cleaning using proper procedures and compatible cleaners are recommended to prolong service life. Tiger Corp. polycarbonate is SUPERCOATED™ on both sides.

CLEANING THE SUPERCOAT™ HARD-COAT

1. Wash with a mild solution of soap or detergent and lukewarm water.
2. Using a soft cloth or sponge, gently wash the sheet to loosen dirt and grime and rinse well with clean water.
3. To prevent water spotting, thoroughly dry with chamois or cellulose sponge.
4. Avoid the use of abrasive cleaners, squeegees and/or other cleaning implements that may mar or gouge the coating.

CLEANING AGENTS WHICH HAVE BEEN FOUND TO BE COMPATIBLE UNDER LABORATORY CONDITIONS:

- Aqueous Solutions of Soaps and Detergents
Windex¹ Top Job² Joy² Mr. Clean²
Fantastik³ Formula 409⁴ Sumalight D12 Brucodecid
- Organic Solvents
Butyl Cellosolve Kerosene Hexel, F.O. 554 Naphtha (VM&P grade)
Neleco-Placer Turco 5042
- Alcohols
Methanol Isopropyl

All residual organic solvents should be removed with a secondary rinse.

GRAFFITI REMOVAL

Butyl cellosolve (for removal of paints, marking pen inks, lipstick, etc.). The use of masking tape, adhesive tape or lint removal tools works well for lifting off old weathered paints.

To remove labels, stickers, etc., the use of kerosene or VM&P naphtha are generally effective. When the solvent will not penetrate sticker material, apply heat (hair dryer) to soften the adhesive and promote removal.

IMPORTANT: If a material is found to be incompatible in a short-term test, it will usually be found to be incompatible in the field. The converse, however, is not always true. Favorable performance is no guarantee that actual end-use conditions have been duplicated. Therefore, these results should be used as a guide only and it is recommended that the user test the products under actual end-use conditions.

MAINTENANCE

RECOMMENDED FILLING INSTRUCTIONS FOR HYDRAULIC RESERVOIRS

When filling or checking the oil level, the unit should be parked on a level surface, shut “OFF”, and allowed sufficient time to cool to ambient temperature. Use caution when removing the pressurized breather. Do not place face over opening when removing the breather.

The reservoir should be filled to the top of the lower sight glass on the side of the tank. Do not over-fill. The reservoir has been over-filled when oil is visible in the upper sight glass. If tank has too much oil, the excess may be expelled through the pressurized breather.

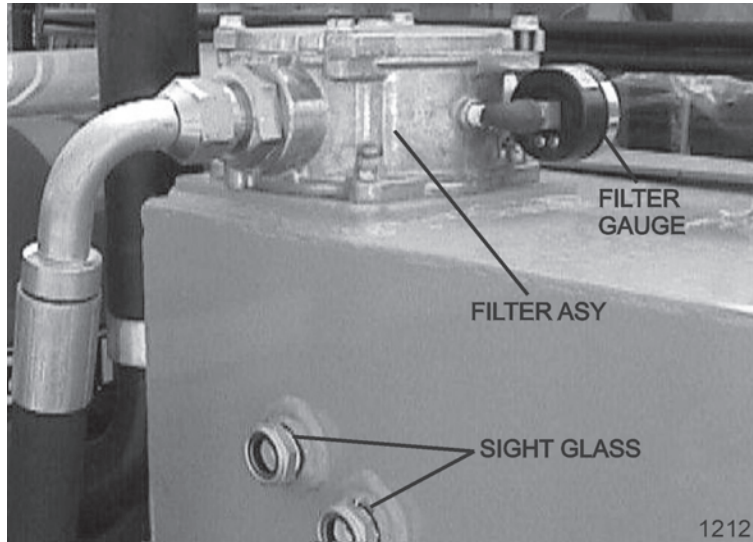

DETAILED MAINTENANCE

REPLACING IN-TANK HYDRAULIC FILTER:

Loosen the four bolts on the top cover of the filter housing. Turn cover counter-clockwise until cover is free. Remove and replace filter. Replace top cover and cover bolts in opposite order as removed.

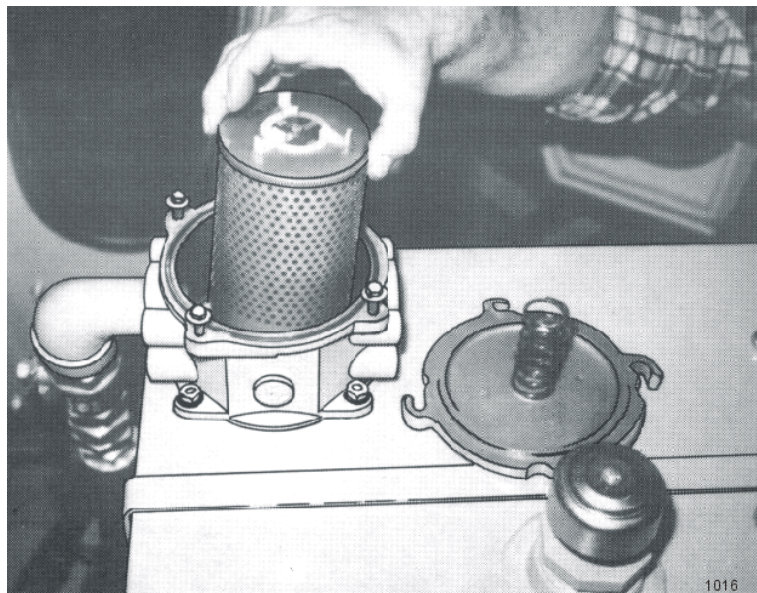

MAINTENANCE

DETAILED MAINTENANCE

REPLACING HIGH PRESSURE HYDRAULIC FILTER ELEMENT:

Assure system has been shut down and de-pressurized. Locate High Pressure Filter housing. Confirm that the element that is about to be installed matches the element p/n on the filter model tag. Example: V3.0510-06 (world line 100, HD049 model) Locate the bottom of the High Pressure Bowl, and use the appropriate spanner wrench –or- ratchet that matches the hex pattern. Using the spanner wrench -or- ratchet and turning in a counterclockwise rotation, (looking at the bottom of the bowl) remove the bowl from the head. The first couple rotations will seam tight as the o-ring passes the sealing flats, once the o-ring has cleared the sealing flats the bowl should spin freely. Taking care not to drop the bowl, finish removing the bowl from the head. **WARNING:** bowl will be full of oil! Pour the oil from the bowl into a container, this oil should be considered contaminated due to the flow direction through the element is outside ~ in. Clean the inside of the bowl if “dirt” is present. Remove the old element from the filter head by pulling with a rotation motion. Dispose of the used element properly. Remove the new element from the packaging. Using your finger, dab and lubricate the o-ring in the top of the new element. Install the new element into and on the mounting boss with in the head; assure that the element is fully seated on the boss. Clean and inspect the o-ring that is affixed in the bowl, lubricate with oil. Using a clockwise rotation, screw the bowl back into the head, assuring that the bowl has not been cross threaded into the head. Continue “tighten” the bowl into the head, using the spanner wrench –or- ratchet, the rotation of the bowl will become tighter once the o-ring engages the sealing flats. Once the bowl has been fully inserted into the head, and the o-ring has reached the sealing flats, the bowl can no longer be “tightened” and bottoms out. Once the bowl has bottomed out, “back-off” the bowl by 1/6 turn, this assures that the o-ring is seated properly with in the sealing flats. Element change out and re-assembly is now complete. Start the machine and inspect the filter area checking that there is no oil leaking from the filter assembly. This is first to be done at 50 hours of operation, then yearly(500 hours) or when indicated by restriction indicator.

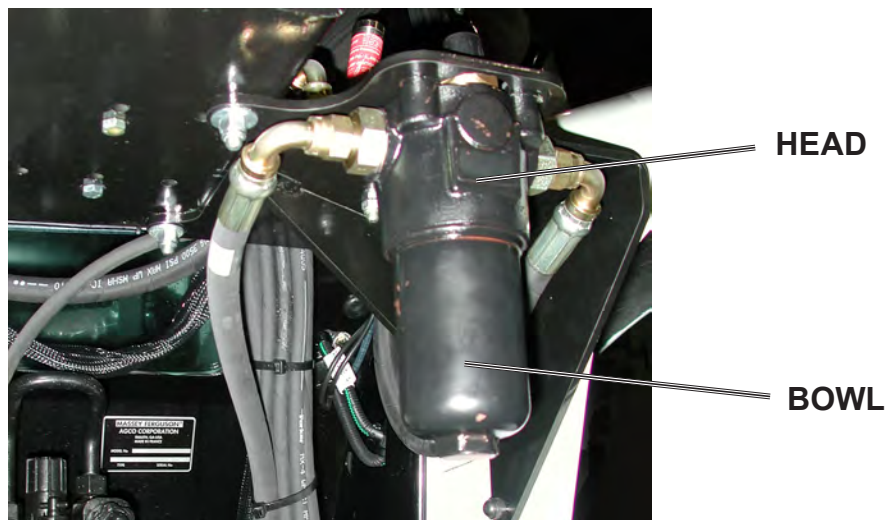

MAINTENANCE

GREASING INNER AND OUTER DRAFT BEAM PIVOT POINTS

Locate the grease zerks on the inner and outer draft beam pivot bosses. Inject Lithium-Complex Extreme Pressure grease conforming to NLGI2-ISO 320 specifications into each zerk until grease protrudes from joints. Grease all pivots daily or every 8 hours of service.

GREASING THE UPPER AND LOWER SHEAVES

Locate the grease zerks on the ends of the upper and lower sheave pins as shown below. Inject Lithium-Complex Extreme Pressure grease conforming to NLGI2-ISO 320 specifications into each pin until it protrudes from the ends. These should also be greased daily or for every 8 hours of service.

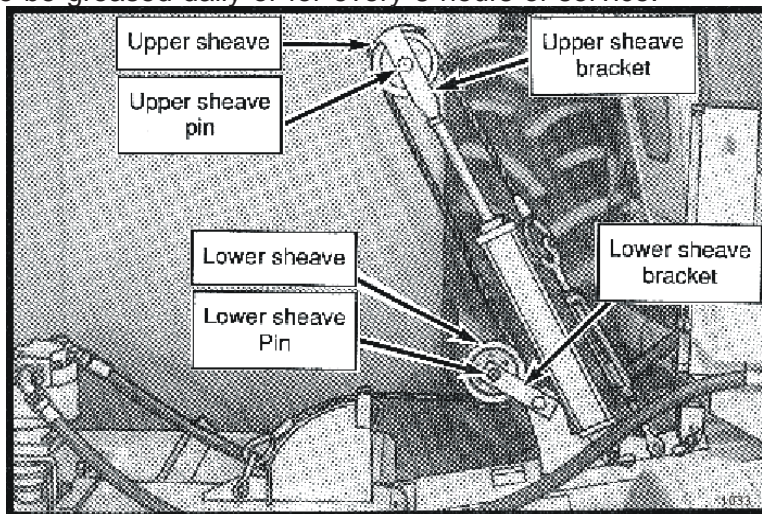

TIGHTENING KNIFE BOLTS AND DISK BOLTS:

After every 8 hours of operation or daily, the Knife Bolts and Disk Bolts should be tightened as follows:

Knife mounting bolts (2ea.) torque oiled to 800 ft. lbs.

Disk mounting bolts (6ea.) torque dry to 204 or oiled to 184 ft lbs

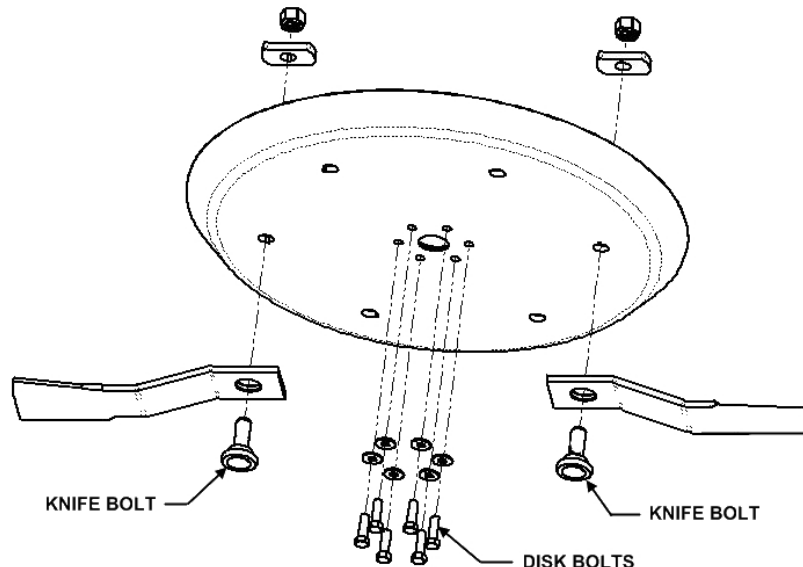

MAINTENANCE

GREASING PUMP DRIVE SHAFT COUPLER

With engine stopped, ensure drive shaft alignment by grasping coupler and sliding back and forth. Coupler should slide freely with approximately 1/8" of end play. If coupler does not slide freely, inspect for loose pump mount bolts, or damaged or loose crank shaft adapter. Inject Lithium-Complex Extreme Pressure grease conforming to NLGI2-ISO 320 specifications into coupler until grease begins to protrude from ends. Grease daily or every 10 hours. Do not over grease.

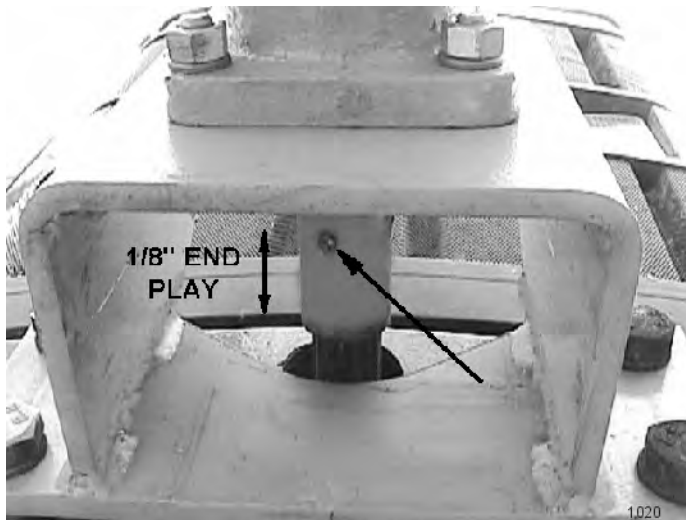

DRIVE SHAFT YOKE, U-JOINT & STUB SHAFT

With engine stopped, inject Lithium-Complex extreme pressure grease conforming to NLGI2-ISO 320 specifications into universal joints and slip yoke until grease appears at the seal. Grease daily or every 10 hours. Do not over grease.

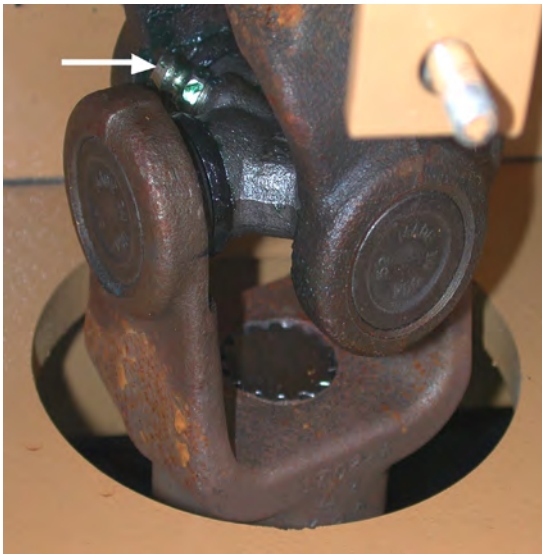

MAINTENANCE

ADJUSTING THE CABLE LIFT

Extend the outboard cylinder until the mower deck touches its stop on the draft beam as shown. NOTE: Make sure the cable turnbuckle is loose enough to allow the cylinder to reach full extension before the head reaches the stop. Now hold the head against the stop and tighten the turnbuckle until the cable is tight. Lower and raise the head to check the adjustment. The head should touch its stop at the same time the cylinder reaches full extension. Tighten turnbuckle lock nuts securely after adjustment is complete.

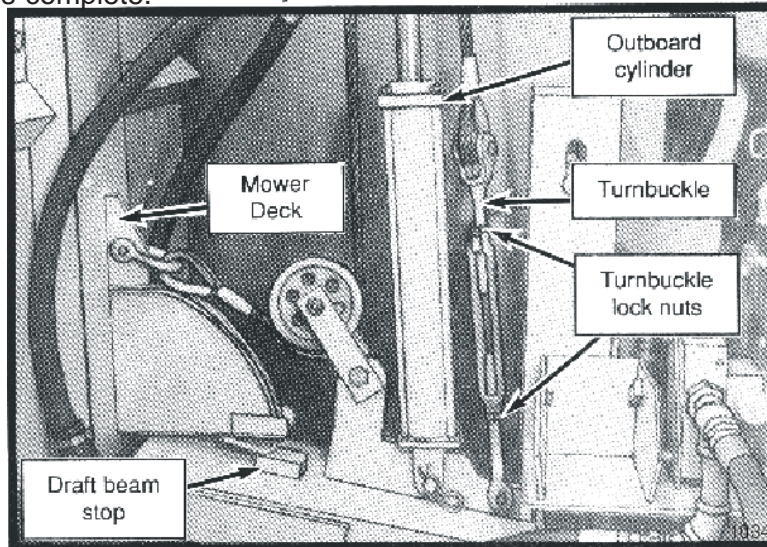

GREASING THE CASTER WHEEL SWIVEL

Locate the grease zerk on the caster wheel swivel boss as shown. Inject Lithium-Complex Extreme Pressure grease conforming to NLGI2-ISO 320 specifications into the boss until the grease protrudes from the ends. Grease daily or every 8 hours of service.

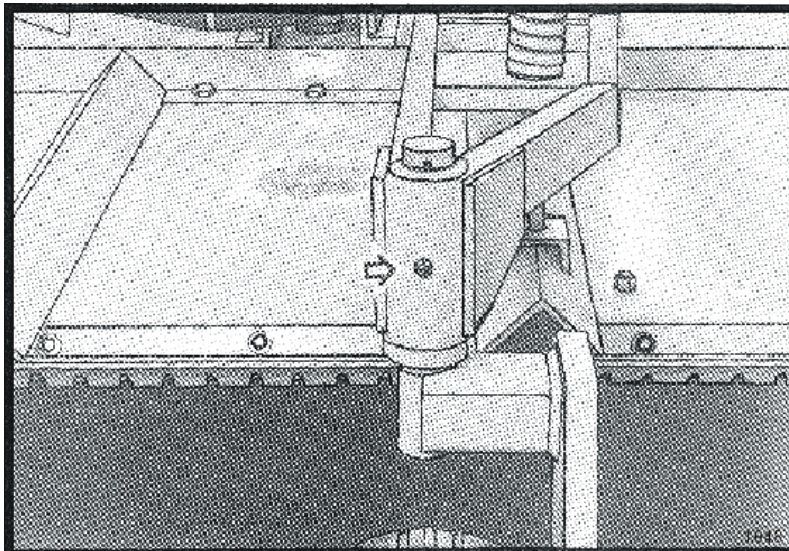

MAINTENANCE

GREASING CASTER FRAME PIVOT POINTS

Locate the grease zerks on the caster frame as shown. Inject Lithium-Complex Extreme Pressure grease conforming to NLGI2-ISO 320 specifications into each zerk until grease begins to protrude from ends. Grease daily or every 8 hours of service.

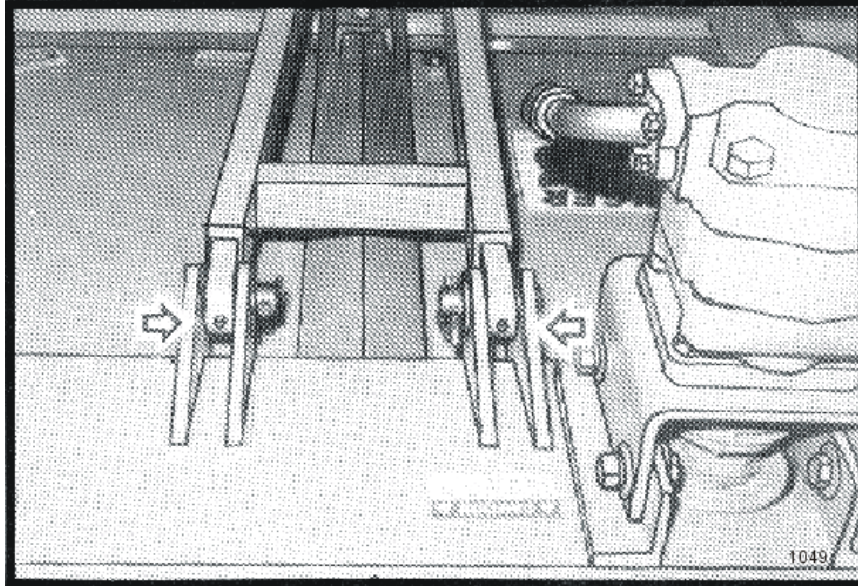

BALL VALVES

The ball valve at the hydraulic reservoir may need to be closed during certain maintenance or repair procedures. **THE BALL VALVES MUST BE OPEN (handle parallel with valve) WHEN TRACT OR IS RE-STARTED OR PUMP IS COUPLED TO MOTOR OR P.T.O. !** Failure to do so may result in component failure!

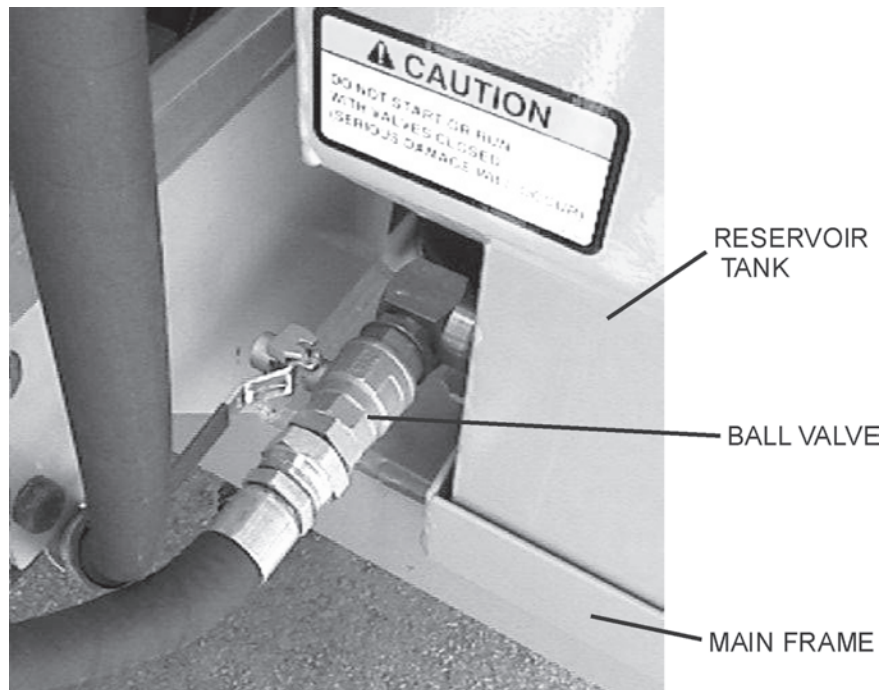

1211

MAINTENANCE

GREASING SPINDLE

Locate grease fitting on inside of deck housing. Inject Tiger Spindle Lubricant, part number 06540000 into spindle housing. Fill with lubricant until lubricant weeps out of the top spindle seal. Lubricate spindle weekly or every 40 hours of use.

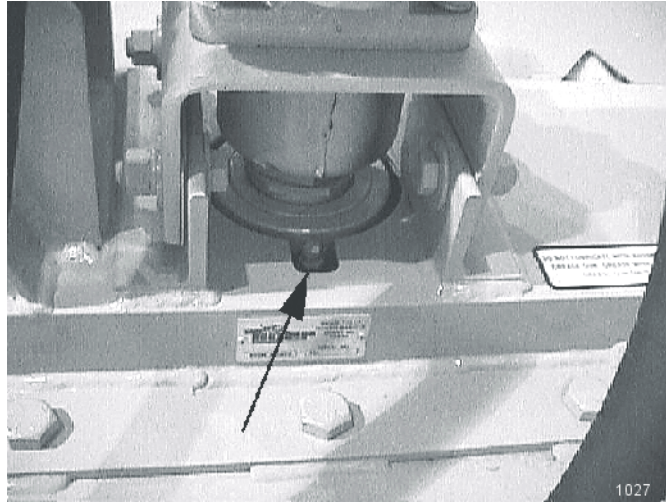

TIGHTENING SPINDLE BOLTS

The spindle mounting bolts should be checked and retorqued daily or every 10 hours of service. Torque the (6) bolts shown below to 331 ft. lbs.

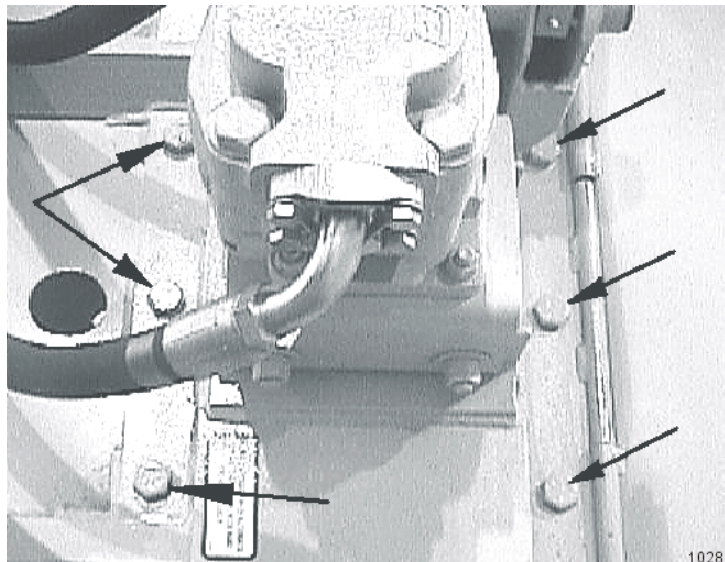

MAINTENANCE

INSPECTION OF ROTARY KNIVES

CAUTION!



Failure to follow the following warnings and instructions may result serious injury or damage to the equipment or property!

- 1 – **DO NOT** weld on the knife or bolts. Damaged or worn knives must be replaced.
- 2 – Knife must be replaced in sets. Knives with unequal wear may cause serious vibration and resulting structural damage to the mower.
- 3 – The self-locking nuts for the knife mounting bolts must **NOT** be reused. If the self-locking nut is removed from the knife mounting bolt, the nut **must** be replaced with a new self-locking nut.
- 4 – Inspect the condition and tightness of the knife mounting bolts and disk mounting bolts daily.

ROTARY KNIFE REPLACEMENT

- 1 – Be sure you have a complete matching set of new knives for replacement.
- 2 – Remove knives and inspect holes for damage. Also watch for cracks in the disk around the holes.
- 3 – Lube threads with anti-seize, motor oil or grease. Install bolt through knife and disk from bottom side of disk. Install new self-locking nuts and torque them to 800 oiled ft. lbs.
- 4 – The knives should swing freely to absorb shocks from impact when striking objects.

WARNING!



WHEN CUTTING HEAVY BRUSH, KNIFE BOLTS SHOULD BE INSPECTED HOURLY AND RETORQUED TO 1070 dry or 800 oiled FT. LBS.

MAINTENANCE

REPLACEMENT OF ROTARY DISK

CAUTION!



Failure to follow the following warnings and instructions may result in serious injury or damage to the equipment or property!

The bolts that attach the knife mounting disk to the spindle must be grade 8. These 5/8 inch bolts are to be torqued to 225 ft. lbs.

A thread locking agent may be applied to threads of all mounting bolts before they are installed.

Disks must be inspected daily for hairline cracks between spindle mounting bolts or around the knife mounting bolts. These cracks indicate metal fatigue caused by severe abuse. If cracks are present, the disk must be replaced.

Inspect the disk mounting bolts daily when checking tightness of knife mounting bolts. If a disk mounting bolt is loose, it must be removed, threads cleaned, fresh thread locking agent applied, and tightened to proper torque value.

If a knife mounting bolt is loose, the self locking nut must be replaced as a safety precaution. Lubricate threads with anti-seize, grease or motor oil. Install bolts through knife and disk from bottom side of disk. Install self locking nuts and torque them to 800 ft. lbs.

- 1- **WARNING:** The disk alone weighs approximately 210 lbs. Be sure its weight can be supported before attempting to replace. The use of a lift mechanism will ease replacement.
- 2- Remove the six disk mounting bolts and the disk from the spindle.
- 3- Install new disk and align with mounting bolt holes.
- 4- Apply a thread locking agent to all of the mounting bolts and install the bolts through the disk. If a bolt protector is being installed, hold the protector in place and install the bolts through the bolt protector and disk. **NOTE:** Disk mounting bolts must be Grade 8.
- 5- Tighten bolts down and torque to values noted.
- 6- See knife replacement instructions for replacing the knives onto the new disk.

MAINTENANCE

HEAVY DUTY SPINDLE ASSEMBLY INSTALLATION AND BEARING ADJUSTMENT

WARNING! A press **MUST** be used to install bearing cups, bearing cones, and seals. **DO NOT** use a hammer to install races, bearings, or seals. The parts of assembly may be damaged.

NOTE: The grease zerk and gussets are located on the top side of the spindle housing. Be sure the spindle is assembled correctly.

Be sure to wear eye protection and other protective equipment as needed when working on spindle assembly.

THE SPINDLE ASSEMBLY

See the diagram below for identification of spindle parts, while servicing.

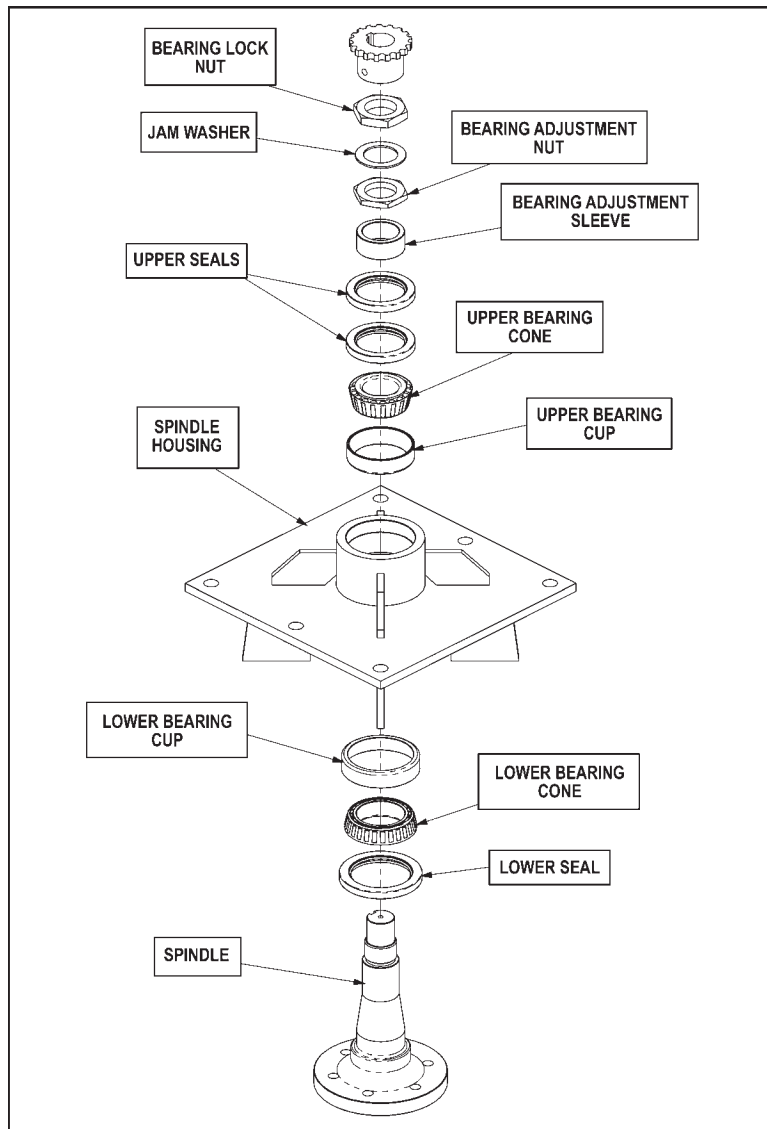

MAINTENANCE

BEARING INSTALLATION

- 1 – Press upper bearing cup into the spindle housing.
 - 2 – Turn the spindle housing over and press in the lower bearing cup.
 - 3 – Place the lower bearing cone in the bearing cup. Next press the seal into the spindle housing. The inner lip of the seal must be DOWN, towards the bearing, so lubricant is sealed inside the housing.
 - 4 – Install the spindle in the housing. Lightly press the spindle to seat the cone onto the spindle.
 - 5 – Support the bottom of the spindle and press the upper bearing cone and bearing adjustment sleeve onto the spindle.
- NOTE:** The spindle housing must turn freely when seating the bearing cone and sleeve.
- 6 – Press the two upper seals into the spindle housing. The inner lip of the seals must be UP, away from the bearing, so excess lubricant can escape.
 - 7 – Install the bearing adjustment nut (thin nut) so there is 1/16" clearance between the nut and the sleeve. Install the jam washer, placing the tab into the key-way. Install the bearing lock nut (thick nut) and hand tighten against jam washer and adjustment nut. See the following section for bearing adjustment.
 - 8 – Position the spindle housing horizontally with the drain hole oriented "up." Grease through the zerk with Tiger Spindle Lubricant(part number 06540000) until the grease purges from the drain hole.
 - 9 – Install the plug into the drain hole.

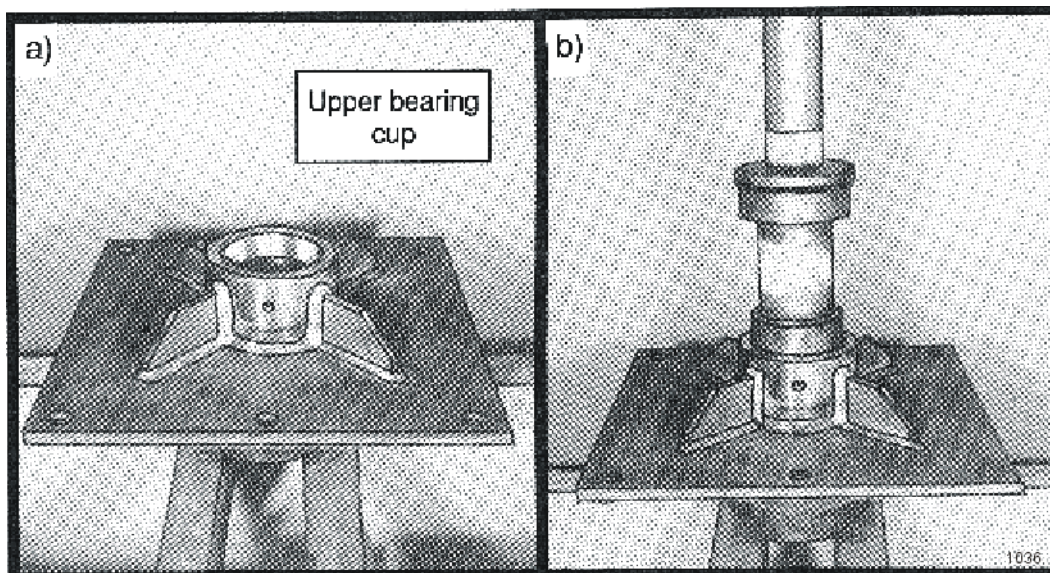

MAINTENANCE

BEARING ADJUSTMENT

- 1 – Clamp the bottom end of the spindle securely in a vise so the spindle housing turns freely.
- 2 – Position a magnetic base dial indicator on the stationary cylinder of the spindle housing. Locate the end of the dial indicator against the flat end of the spindle shaft. The dial indicator will now measure accurately bearing end play.
- 3 – Tighten the bearing adjustment nut until there is .012 inch movement when the spindle housing is pried upward away from the vise jaws.
- 4 – When there is .012 inch free play between the spindle and housing, install the bearing lock nut (thick nut). Hold the adjusting nut securely and tighten the lock nut to 300 ft. lbs. of torque.
- 5 – After the lock nut is tightened, there must be .001 inch to .003 inch of free play when lightly prying up on the spindle housing.

If the end play is correct, .001 inch to .003 inch, bend tabs up on jam washer to prevent the lock nut from loosening.

If the end play is NOT correct, loosen the lock nut and turn the adjustment nut as required and re-tighten the lock nut. Repeat first part of step 5.

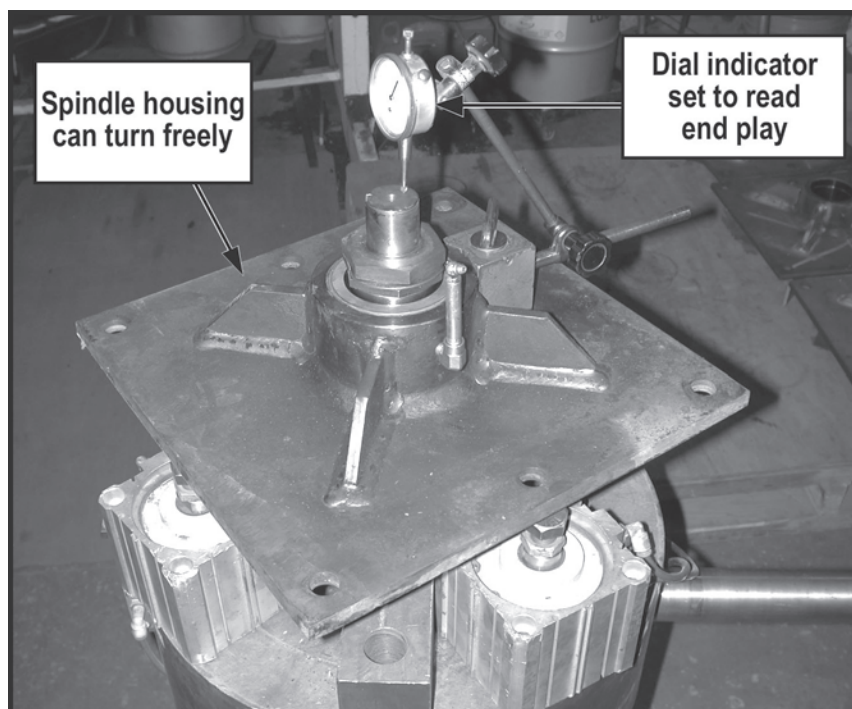

MAINTENANCE

DAILY MAINTENANCE SCHEDULE

The following services should be performed **daily** or every **8 hours** of service, following the detailed maintenance instructions in the operators manual.

- _____ Pump Drive Shaft: If required with drive shaft / coupler check for end play and lubricate at zerks.
- _____ Crankshaft adapter: If equipped with rubber grommets check condition, replace if missing or damaged.
- _____ Pivot points: Inject grease until it appears at ends.
- _____ Hydraulic fittings: Check for leaks with paper or cardboard. Tighten fittings or replace hoses immediately.
- _____ Knives: Inspect for missing or damaged knives, change (only complete sets) as needed.
- _____ Belts: Check / Tighten / Replace belts as needed.
- _____ Main Frame / Deck: Unless otherwise specified retorque bolts according to torque specifications in this section.
- _____ Hydraulic Fluid Level: Add, if required, per fluid recommendations.
- _____ Rear Flail Drive, Bearing
Flange and Shaft Couplers: Grease as instructed in the detailed (if applicable) maintenance section.
- _____ Cutter Shaft and Ground Roller: Grease as instructed in the detailed maintenance section

Service performed by: _____ Date: ____/____/____ Hour
Meter: _____

Maintenance Section

** This page may be copied and used as part of the daily maintenance routine.

JD 72-7400 CAB, TWIN ROTARY

**PARTS
SECTION**

PARTS ORDERING GUIDE

The following instructions are offered to help eliminate needless delay and error in processing purchase orders for the equipment in this manual.

1. The Parts Section is prepared in logical sequence and grouping of parts that belong to the basic machine featured in this manual. Part Numbers and Descriptions are given to help locate the parts and quantities required.

2. The Purchase Order must indicate the **Name and Address** of the person or organization ordering the parts, **who should be charged**, and if possible, the **serial number of the machine** for which the parts are being ordered.

3. The purchase order must clearly list the **quantity of each part**, the complete and correct **part number**, and the basic **name of the part**.

4. The manufacturer reserves the right to substitute parts where applicable.

5. Some parts may be unlisted items which are special production items not normally stocked and are subject to special handling. Request a quotation for such parts before sending a purchase order.

6. The manufacturer reserves the right to change prices without prior notice.

NOTE: When ordering replacement decals, refer to the part numbers and descriptions listed in the safety section in the front of this manual.



1000

For maximum safety and to guarantee optimum product reliability, always use genuine **Tiger** replacement parts. The use of inferior replacement parts may cause premature or catastrophic failure which could result in serious injury or death.

Direct any questions regarding parts to:

Tiger Corporation
3301 N. Louise Ave.
Sioux Falls, SD 57107
1-800-843-6849
1-605-336-7900

PARTS SECTION TABLE OF CONTENTS

| SECTION | ASSEMBLY | PAGE |
|--|-----------------|-------------|
| TRACTOR SPECIFIC PARTS: | | |
| TRACTOR MOUNT KIT – MAIN FRAME, CAB, 4WD | 06100755 | 5-4 |
| TRACTOR MOUNT KIT - HYDRAULICS | 06100755 | 5-6 |
| TRACTOR MOUNT KIT - CYLINDER HOOKUP | 06100755 | 5-8 |
| COMBO LIFT VALVE - ROTARY, CAB, 2-SP | 06100516 | 5-10 |
| HYDRAULIC COOLER ASSEMBLY - CAB | 06100715 | 5-12 |
| SOLENOID VALVE SWITCH AND WIRING | 80118 | 5-14 |
| COMMON PARTS SECTION: | | 6-1 |

TRACTOR MOUNT KIT - MAIN FRAME, CAB, 4WD

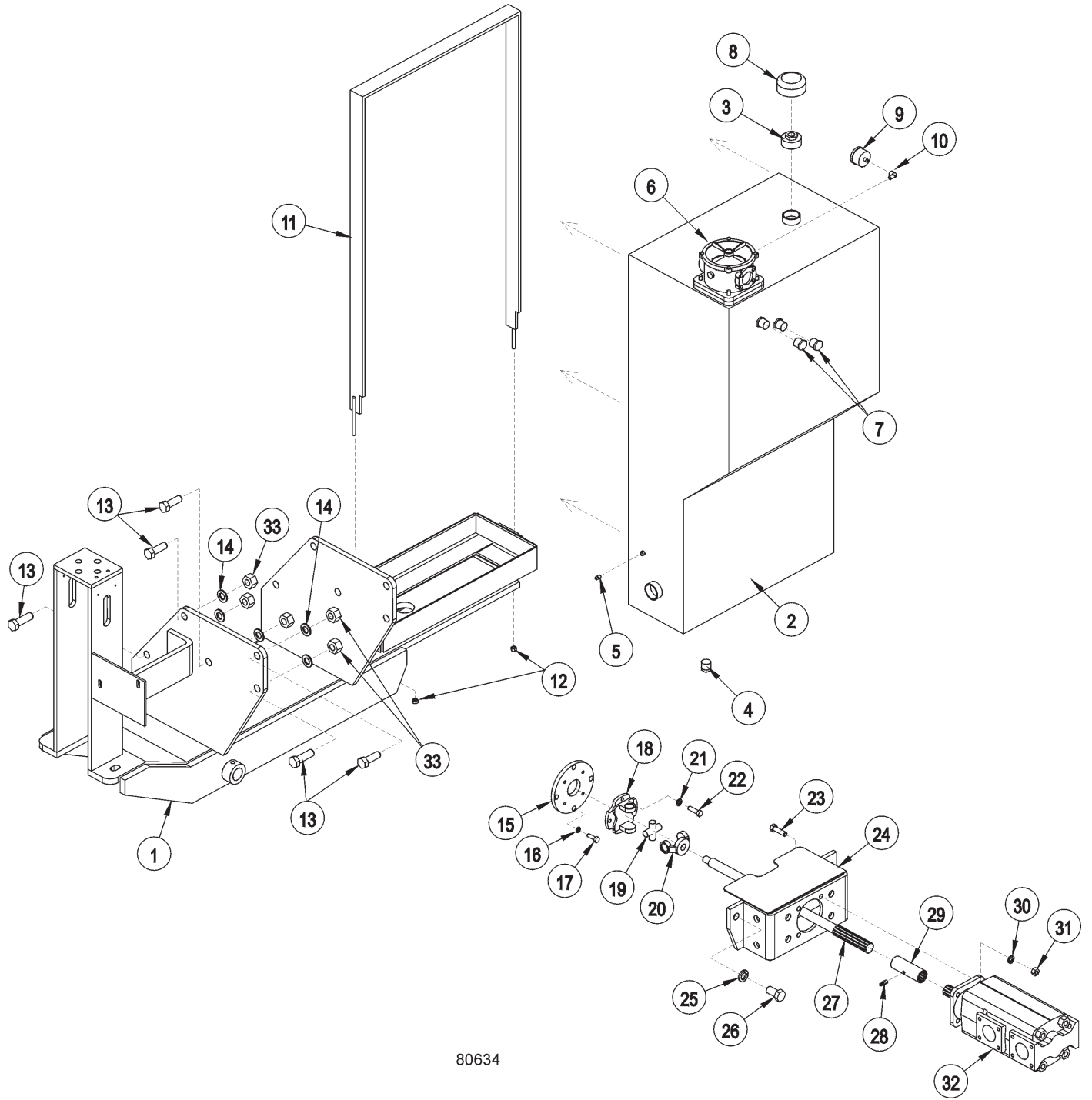

80634

TRACTOR MOUNT KIT - MAIN FRAME, CAB, 4WD

| ITEM | PART NO. | QTY. | DESCRIPTION |
|------|---------------|--------------|-------------------------------|
| 1 | 30791 | 1 | MAIN FRAME |
| * | 28193 | AVAIL | RESERVOIR TANK ASY |
| 2 | 28192D | 1 | RESERVOIR TANK |
| 3 | 33700 | 1 | REDUCER BUSHING |
| 4 | 6T4200 | 1 | PIPE PLUG |
| 5 | 6T4197 | 1 | PIPE PLUG |
| 6 | 6T0640 | 1 | IN-TANK FILTER ASY |
| 7 | 6T1209 | 2 | TANK SIGHT GLASS |
| 8 | 31004 | 1 | TANK BREATHER |
| 9 | 6T0649 | 1 | FILTER GAUGE |
| 10 | TF4888 | 1 | STREET ELBOW |
| 11 | 28191B | 1 | RESERVOR TANK STRAP |
| 12 | 21627 | 2 | NYLOCK NUT 3/8" |
| 13 | 24879 | 10 | CAPSCREW 20MM X 65MM |
| 14 | 24881 | 10 | LOCKWASHER 20MM |
| 15 | 28853A | 1 | CRANKSHAFT ADAPTER PLATE |
| 16 | 32691 | 4 | LOCKWASHER |
| 17 | 6T2501 | 4 | CAPSCREW |
| * | 24983A | AVAIL | CRANKSHAFT ADAPTER ASY |
| 18 | 24984B | 1 | YOKE ADAPTER PLATE |
| 19 | 24975 | 1 | BEARING U-JOINT KIT |
| 20 | 24974 | 1 | YOKE WITH THREADED INSERT |
| 21 | 21987 | 4 | LOCKWASHER 5/16" |
| 22 | 21580 | 4 | CAPSCREW 5/16" X 1" |
| 23 | 21732 | 4 | CAPSCREW 1/2" X 1 3/4" |
| 24 | 32622 | 1 | PUMP MOUNTING BRACKET |
| 25 | 24881 | 4 | FLATWASHER 20MM |
| 26 | 24860 | 4 | CAPSCREW 20MM X 40MM |
| 27 | 32639 | 1 | PUMP DRIVE SHAFT |
| 28 | 6T2307 | 1 | GREASE ZERK 1/4" STRAIGHT |
| 29 | 6T0375B | 1 | SPLINE COUPLING WITH ZERK |
| 30 | 21990 | 4 | LOCKWASHER 1/2" |
| 31 | 21725 | 4 | HEX NUT 1/2" |
| 32 | 22679 | 1 | TANDUM PUMP |
| 33 | 31722 | 10 | HEX NUT 20MM |

TRACTOR MOUNT KIT - HYDRAULICS

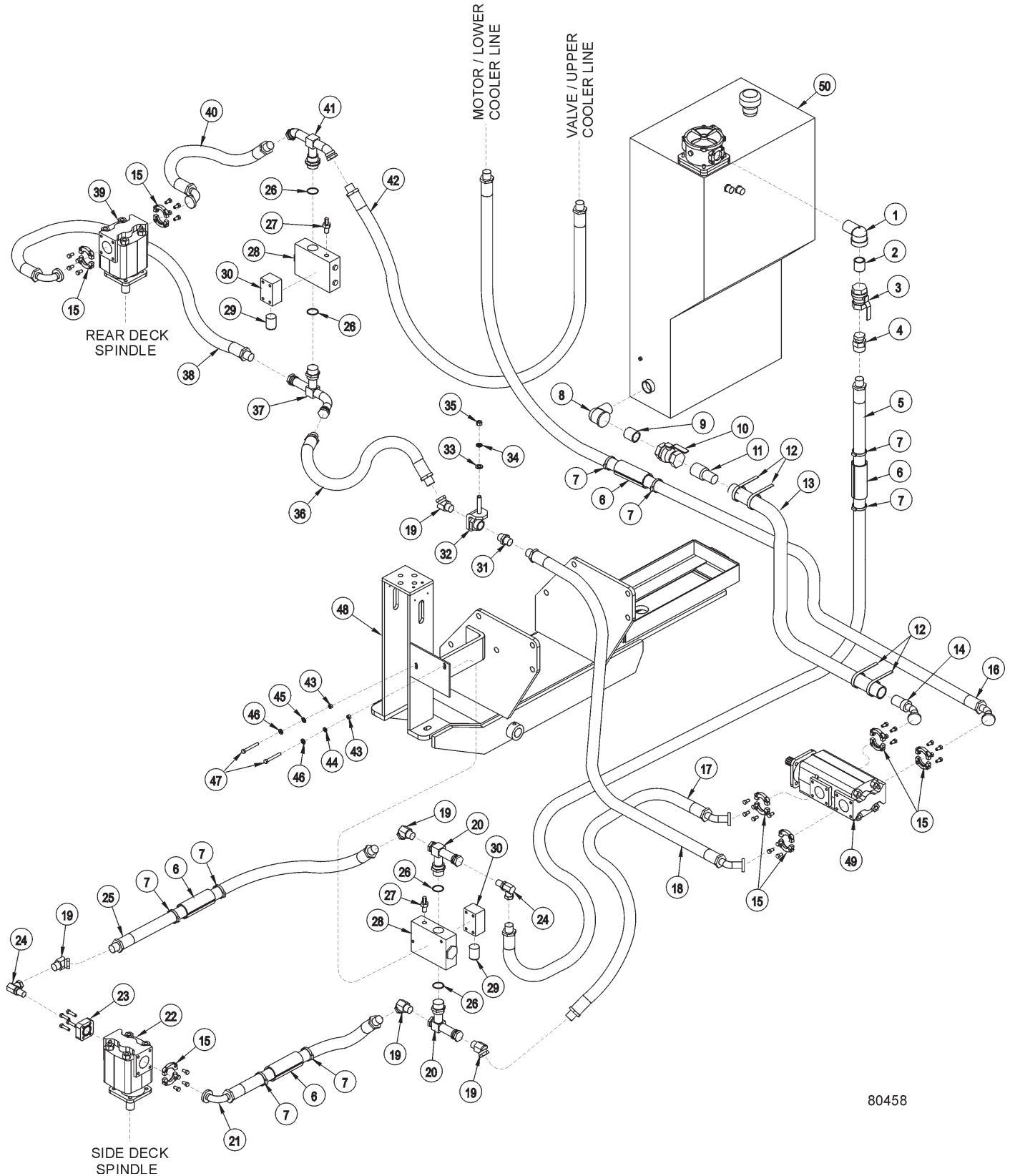

TRACTOR MOUNT KIT - HYDRAULICS

| ITEM | PART NO. | QTY. | DESCRIPTION |
|-----------|--------------|--------------|---|
| 1 | 6T3601 | 1 | ELBOW 1 1/4" X 90 |
| 2 | 6T3825 | 1 | NIPPLE 1 1/4" |
| 3 | 6T4237 | 1 | BALL VALVE 1 1/4" |
| 4 | 22890 | 1 | SWIVEL 1 1/4" |
| 5 | 22858 | 1 | HOSE 1" X 90" |
| 6 | 6T3200 | 4 | SPLIT HOSE |
| 7 | 23568 | 8 | HOSE CLAMP |
| 8 | 6T3612 | 1 | ELBOW 1 1/2" X 90 |
| 9 | 6T3801 | 1 | NIPPLE 1 1/2" |
| 10 | 6T4238 | 1 | BALL VALVE 1 1/2" |
| 11 | 6T3800 | 1 | KING NIPPLE 1 1/2" |
| 12 | 6T3018 | 4 | BANDIT CLAMP |
| 13 | 22897 | 6' | SUCTION HOSE 1 1/2" |
| 14 | 22631 | 1 | KING NIPPLE / FLANGE 45 |
| 15 | TF4852 | 7 | FLANGE KIT #20 |
| 16 | 30106 | 1 | HOSE 1" X 223" |
| 17 | 30802 | 1 | HOSE 1" X 68" |
| 18 | 31888 | 1 | HOSE 1" X 172" |
| 19 | TF4869 | 5 | SWIVEL 1" MP 45 |
| 20 | 24030 | 1 | PREFORMED TEE |
| 21 | 23880 | 1 | HOSE 1" X 70" |
| 22 | 22680 | 1 | MOTOR 2" |
| 23 | TF4850 | 1 | ADAPTER BLOCK FLANGE #20 |
| 24 | TF4870 | 2 | SWIVEL 1" MP 90 |
| 25 | 23878 | 1 | HOSE 1" X 78" |
| 26 | 6T3904A | 4 | O-RING |
| * | 27360 | AVAIL | SOLENOID VALVE ASY |
| 27 | 6T3910 | 2 | RELIEF VALVE |
| 28 | 27398 | 2 | SOLENOID BODY |
| 29 | 6T3906 | 2 | SOLENOID CARTRIDGE |
| 30 | 6T3907 | 2 | SOLENOID BLOCK |
| 31 | TF4868 | 1 | SWIVEL 1" MP |
| 32 | 23283A | 1 | UNION BLOCK 1" |
| 33 | 22018 | 1 | FLATWASHER 1/2" |
| 34 | 21990 | 1 | LOCKWASHER 1/2" |
| 35 | 21725 | 1 | HEX NUT 1/2" |
| 36 | 22666 | 1 | HOSE 1" X 62 1/2" |
| 37 | 24031 | 1 | PREFORMED TEE |
| 38 | 22667 | 1 | HOSE 1" X 31" |
| 39 | 21469 | 1 | MOTOR 1 3/4" |
| 40 | 22668 | 1 | HOSE 1" X 24" |
| 41 | 24032 | 1 | PREFORMED TEE |
| 42 | 24466 | 1 | HOSE 1" X 182 |
| 43 | 21625 | 2 | HEX NUT 3/8" |
| 44 | 21988 | 1 | LOCKWASHER 3/8" |
| 45 | 6T2665 | 1 | STAR LOCKWASHER 3/8" |
| 46 | 22016 | 2 | FLATWASHER 3/8" |
| 47 | 21638 | 2 | CAPSCREW 3/8" X 3" |
| 48 | * | REF | MAIN FRAME - REFER TO MAIN FRAME PARTS |
| 49 | * | REF | TANDUM PUMP - REFER TO MAIN FRAME PARTS |
| 50 | * | REF | RESERVOIR TANK - REFER TO MAIN FRAME PARTS |

TRACTOR MOUNT KIT - CYLINDER HOOKUP

CYLINDER REPLACES
TRACTOR LEFT REAR
3-POINT ARM

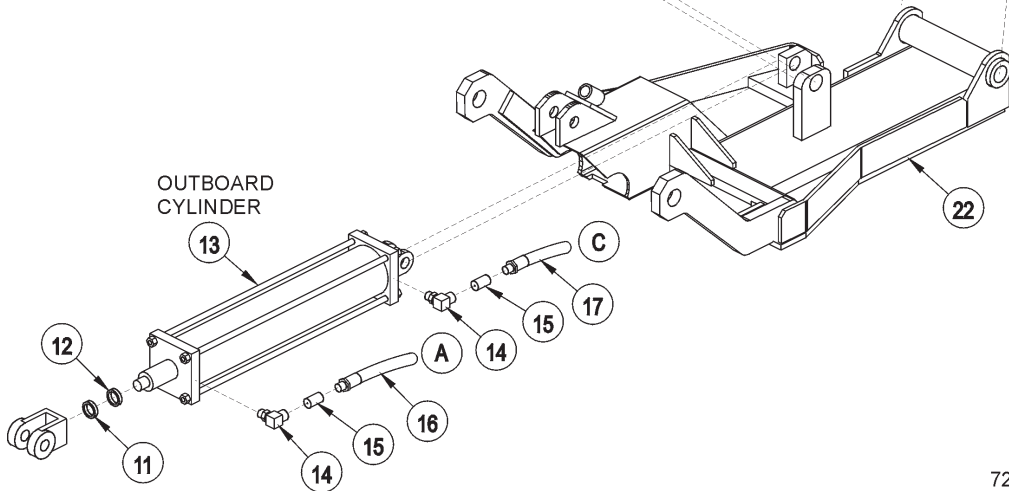
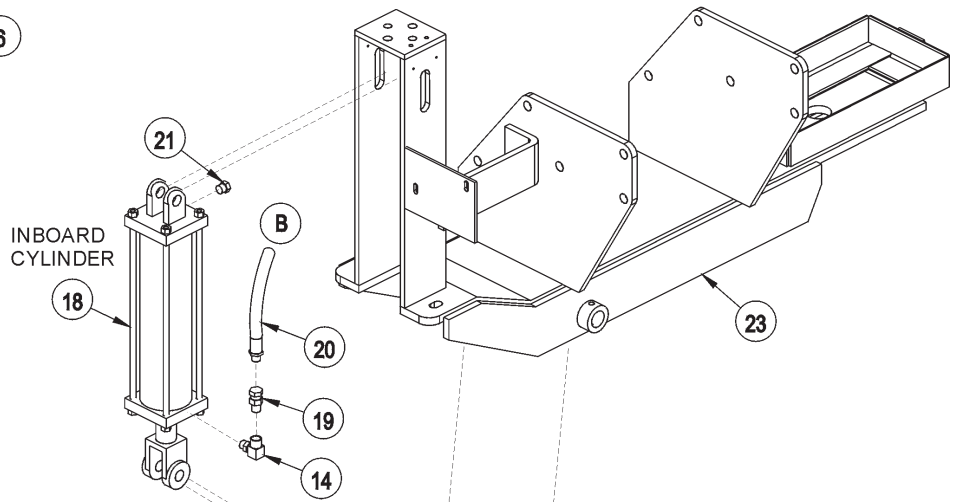
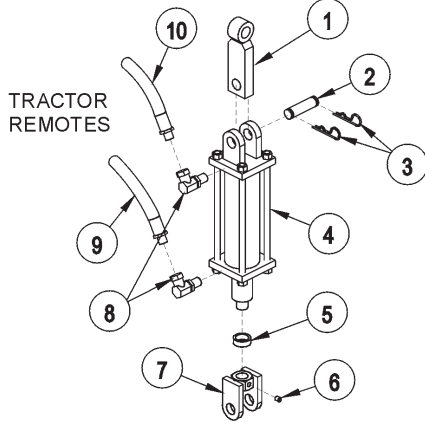

72 TWIN CYLINDER HOOKUP

TRACTOR MOUNT KIT - CYLINDER HOOKUP

| ITEM | PART NO. | QTY. | DESCRIPTION |
|-----------|----------|------------|---|
| 1 | 31807 | 1 | UPPER CYLINDER CLEVIS |
| 2 | 6T3003 | 1 | PIN 1" X 3 1/2" |
| 3 | 6T3004 | 2 | R - CLIP |
| 4 | 30481 | 1 | CYLINDER 3" X 8" |
| 5 | 31208 | 1 | SPACER 1/2" |
| 6 | 6T2272 | 1 | SETSCREW 3/8" X 1/2" |
| 7 | 31810 | 1 | LOWER CYLINDER CLEVIS |
| 8 | * | REF | SWIVEL - REFER TO COMBO LIFT VALVE |
| 9 | * | REF | HOSE - REFER TO COMBO LIFT VALVE |
| 10 | * | REF | HOSE - REFER TO COMBO LIFT VAVLE |
| 11 | 22076 | 1 | SPACER 1/4" (AS REQUIRED) |
| 12 | 22077 | 1 | SPACER 5/16" (AS REQUIRED) |
| 13 | 25343 | 1 | OUTBOARD CYLINDER 3" X 12" |
| 14 | 6T0157 | 3 | FITTING 1/2" X 90 |
| 15 | 6T4256 | 2 | RESTRICTOR NPT |
| 16 | * | REF | HOSE - REFER TO COMBO LIFT VALVE |
| 17 | * | REF | HOSE - REFER TO COMBE LIFT VAVLE |
| 18 | 6T0151R | 1 | INBOARD CYLINDER 3" X 10" |
| 19 | 31189 | 1 | RESTRICTOR .0625 |
| 20 | * | 1 | HOSE - REFER TO COMBO LIFT VALVE |
| 21 | 6T4258 | 1 | BREATHER 1/2" |
| 22 | * | REF | DRAFT BEAM - REFER TO COMMON ASY PARTS |
| 23 | * | REF | MAIN FRAME - REFER TO MAIN FRAME PARTS |

COMBO LIFT VALVE - TWIN ROTARY, CAB, 2-SPOOL

HOSE ROUTING

- A - TO OUTBOARD CYLINDER GLAND
- B - TO INBOARD CYLINDER GLAND
- C - TO OUTBOARD CYLINDER BUTT

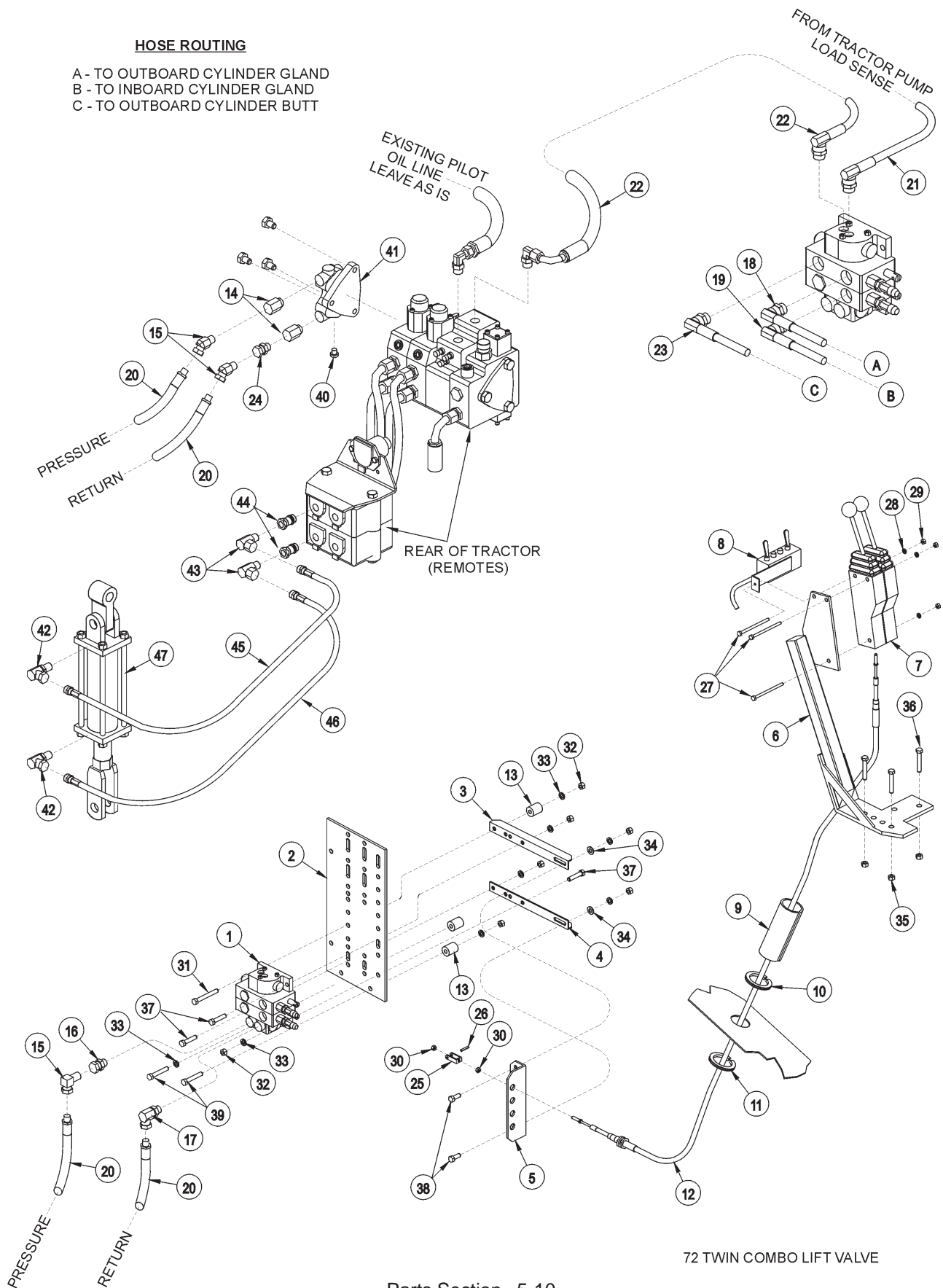

COMBO LIFT VALVE - TWIN ROTARY, CAB, 2-SPOOL

| ITEM | PART NO. | QTY. | DESCRIPTION |
|------|----------|------|--|
| 1 | 31321 | 1 | VALVE 2SP |
| 2 | 28856C | 1 | VALVE MOUNTING PLATE |
| 3 | 22148-2D | 1 | VALVE MOUNTING ANGLE |
| 4 | 22148-1D | 1 | VALVE MOUNTING ANGLE |
| 5 | 6T4325 | 1 | CABLE REMOTE MOUNTING BRACKET |
| 6 | 23865B | 1 | CABLE CONTROLS MOUNTING BRACKET |
| 7 | 6T1251 | 2 | CABLE CONTROL BOX |
| 8 | 31297 | 1 | DOUBLE SWITCH BOX WITH MTG. BRACKET |
| 9 | 6T3200 | 1 | SPLIT HOSE - SECURE WITH ZIP TIES |
| 10 | TB3440 | 8" | TRIM LOCK |
| 11 | 28053 | 8" | TRIM LOCK |
| 12 | 31356 | 2 | CABLE CONTROL 60" |
| 13 | 27082B | 3 | SPACER |
| 14 | 30548 | 2 | ADAPTER 22MM |
| 15 | 27145 | 3 | SWIVEL 1/2" X 90 |
| 16 | TB1094 | 1 | SWIVEL 5/8" X 1/2"FPX |
| 17 | TB1095 | 1 | SWIVEL 5/8" X 1/2"FPX 90 |
| 18 | 28934 | 1 | HOSE 1/4" X 90" |
| 19 | 30210 | 1 | HOSE 1/4" X 109" |
| 20 | 6T1413 | 2 | HOSE 1/2" X 60" |
| 21 | 31978 | 1 | HOSE 1/4" x 52" |
| 22 | 31977 | 1 | HOSE 1/4" x 52" |
| 23 | 28988 | 1 | HOSE 1/4" X 90" |
| 24 | 6T4240 | 1 | SWIVEL 1/2" |
| 25 | 6T4411 | 2 | CLEVIS -CABLE |
| 26 | 6T3017 | 2 | ROLL PIN |
| 27 | 21542 | 3 | CAPSCREW - 1/4" X 4" |
| 28 | 21525 | 3 | HEX NUT - 1/4" |
| 29 | 21986 | 3 | LOCKWASHER - 1/4" |
| 30 | 21500 | 4 | HEX NUT - 1/4" NF |
| 31 | 21638 | 1 | CAPSCREW - 3/8" X 3" |
| 32 | 21625 | 7 | HEX NUT - 3/8" |
| 33 | 21988 | 8 | LOCKWASHER - 3/8" |
| 34 | 22016 | 2 | FLATWASHER - 3/8" |
| 35 | 21627 | 3 | NYLOCK NUT - 3/8" |
| 36 | 21635 | 3 | CAPSCREW - 3/8" X 2 1/4" |
| 37 | 21633 | 3 | CAPSCREW - 3/8" X 1 3/4" |
| 38 | 21630 | 2 | CAPSCREW - 3/8" X 1" |
| 39 | 21636 | 2 | CAPSCREW - 3/8" X 2 1/2" |
| 40 | 32405 | 1 | PIPE PLUG 12MM |
| 41 | AL77030 | 1 | TRACTOR VALVE END CAP |
| 42 | 6T0158 | 2 | SWIVEL 1/2" |
| 43 | TF4879 | 2 | SWIVEL 1/2" |
| 44 | 6T4221 | 2 | QUICK COUPLER |
| 45 | TB2003 | 1 | HOSE 1/4" X 24" |
| 46 | 24303 | 1 | HOSE 1/4" X 26" |
| 47 | * | | CYLINDER REPLACES 3-POINTARM - SEE TR. MNT. KIT |

HYDRAULIC COOLER ASSEMBLY - CAB

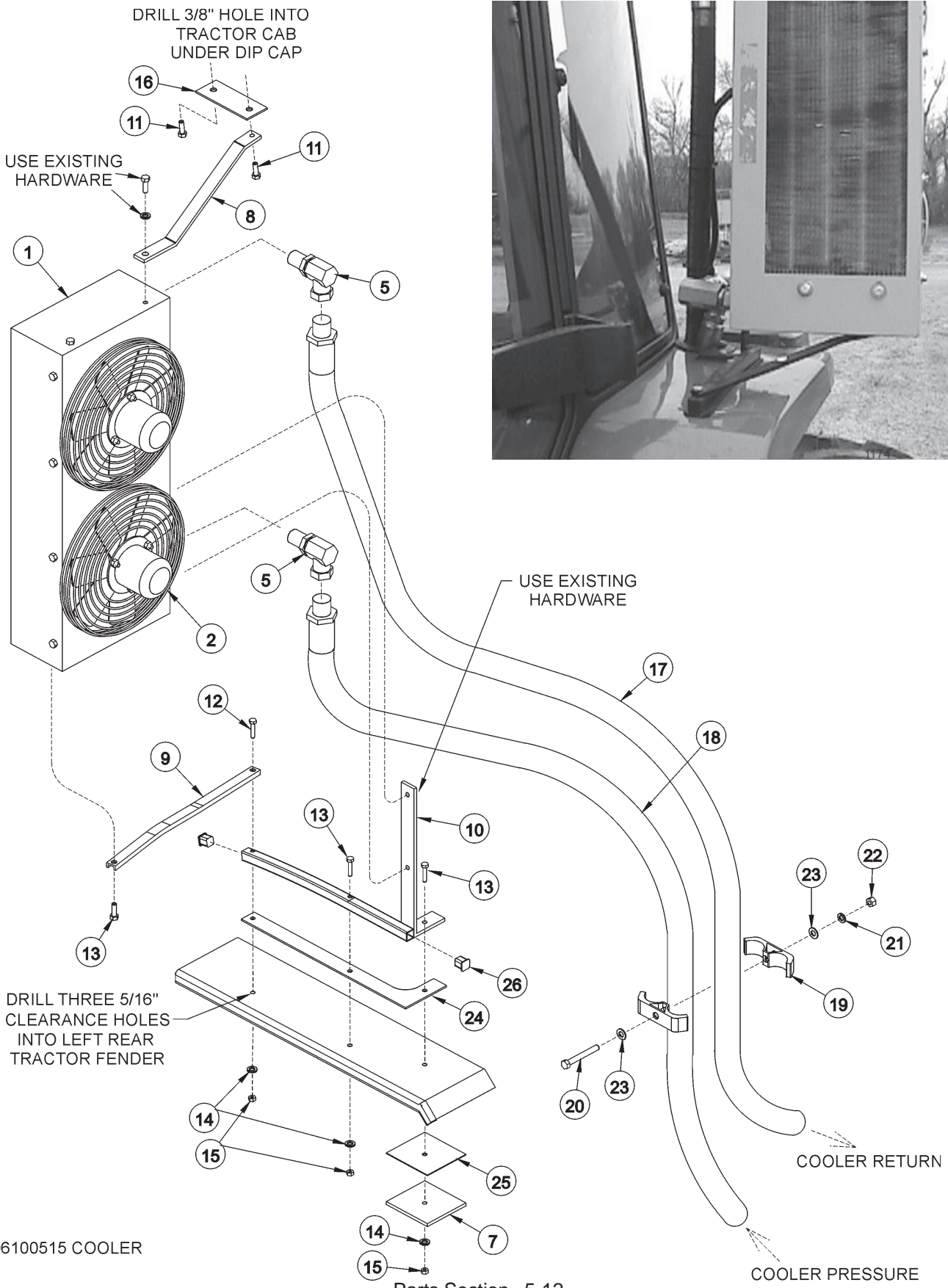

06100515 COOLER

Parts Section 5-12

HYDRAULIC COOLER ASSEMBLY - CAB

| ITEM | PART NO. | QTY. | DESCRIPTION |
|------|--------------|---------------|---------------------------------------|
| 1 | 30206 | 1 | COOLER ASSY. |
| 2 | 27053 | AVAIL. | FAN ASSY. |
| | TF4615 | 2 | FAN BLADE |
| | TF4616 | 2 | FAN GUARD |
| | TF4617 | 2 | MOTOR BRACKET |
| | TF4618 | 2 | MOTOR |
| 3 | 22763 | 2 | ELBOW 3/4" MP |
| 4 | TF4868 | 1 | SWIVEL 1" MP |
| 5 | TF4870 | 1 | SWIVEL 1" MP 90 |
| 6 | TF4869 | 1 | SWIVEL 1" MP 45 |
| 7 | 30229 | 1 | FENDER BRACKET |
| 8 | 31892 | 1 | UPPER COOLER BRACKET |
| 9 | 32757 | 1 | SUPPORT CHANNEL |
| 10 | 32756 | 1 | LOWER COOLER BRACKET / FENDER SUPPORT |
| 11 | 21630 | 2 | CAPSCREW 3/8" X 1" |
| 12 | 21532 | 1 | CAPSCREW 1/4" X 1 1/2" |
| 13 | 21531 | 3 | CAPSCREW 1/4" X 1 1/4" |
| 14 | 21986 | 3 | LOCKWASHER 1/4" |
| 15 | 21525 | 3 | HEX NUT 1/4" |
| 16 | 31891 | 1 | TOP COOLER PLATE |
| 17 | * | REF | HOSE - TO PUMP SUCTION |
| 18 | * | REF | HOSE - FROM REAR SOLENOID VALVE |
| 19 | TB3031 | 1 | DOUBLE TUBE CLAMP |
| 20 | 21587 | 1 | CAPSCREW 5/16" X 2 3/4" |
| 21 | 21987 | 1 | LOCKWASHER 5/16" |
| 22 | 21575 | 1 | HEX NUT 5/16" |
| 23 | 22015 | 2 | FLATWASHER 5/16" |
| 24 | 30306 | 1 | RUBBER PAD, FENDER SUPPORT |
| 25 | 30307B | 1 | RUBBER PAD, FENDER BRACKER |
| 26 | 30180 | 2 | PLASTIC PLUG |

PUMP DRIVESHAFT ASSEMBLY

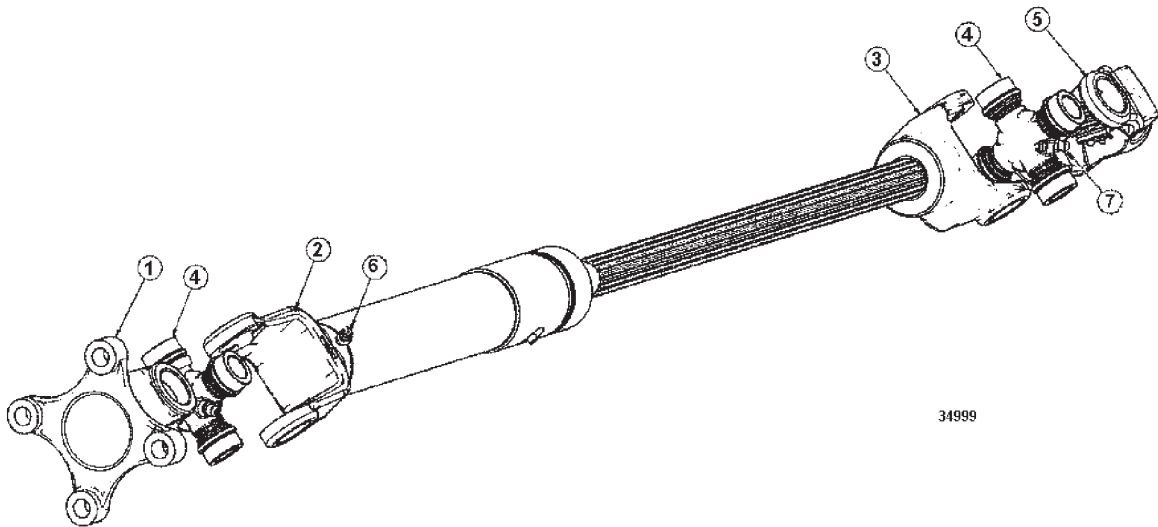

| ITEM | PART NO. | QTY. | DESCRIPTION |
|------|--------------|------------|---------------------------|
| * | 34999 | AVA | DRIVESHAFT,U-JOINT |
| 1 | 06505004 | 1 | YOKE PULLEY, 34999 |
| 2 | 06505005 | 1 | SLEEVE, 34999 |
| 3 | 06505006 | 1 | SHAFT, 34999 |
| 4 | 06505007 | 2 | CROSS, 34999 |
| 5 | 06505008 | 1 | YOKE DRIVE, 34999 |
| 6 | 6T3203 | 1 | GREASE ZERK, 1/4 X 45 |
| 7 | 6T3207 | 3 | GREASE ZERK, 1/4 X STR |

SOLENOID VALVE SWITCH AND WIRING

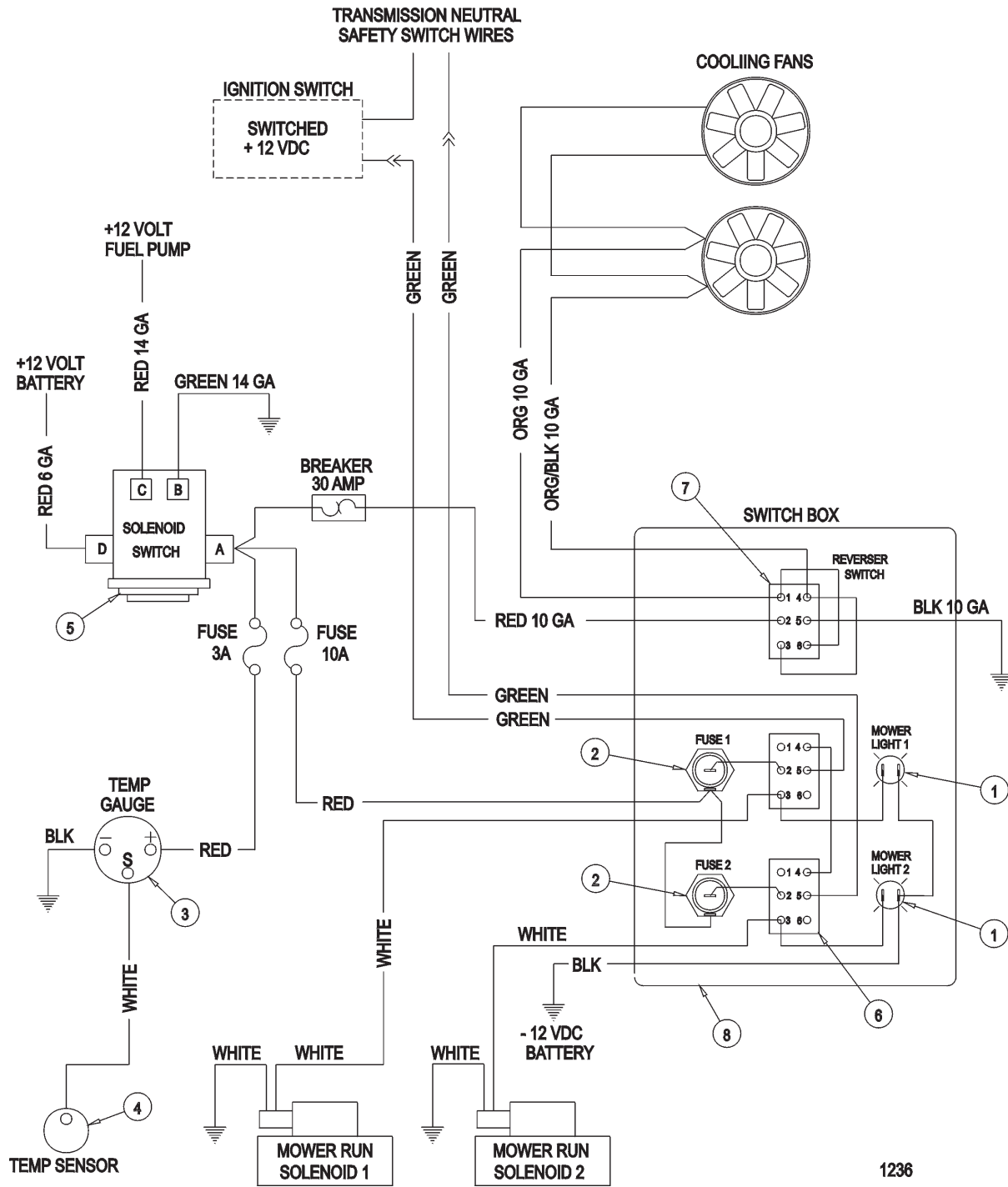

1236

| ITEM | PART NO. | QTY. | DESCRIPTION |
|------|--------------|--------------|----------------------------------|
| | 34522 | AVAIL | SWITCH BOX ASY (COMPLETE) |
| 1 | 6T3923 | 1 | INDICATOR LIGHT |
| 2 | 6T3924 | 1 | FUSE HOLDER |
| 3 | 6T3934 | OPT. | TEMPERATURE GAUGE |
| 4 | 6T3931 | OPT. | TEMPERATURE SENSOR |
| 5 | 6T3927 | 1 | CONTINUOUS SOLENOID SWITCH |
| 6 | PT3905A | 1 | TOGGLE SWITCH, MOWER RUN |
| 7 | 30260 | 1 | TOGGLE SWITCH, REVERSER SWITCH |
| 8 | 34325 | 1 | SWITCH BOX |

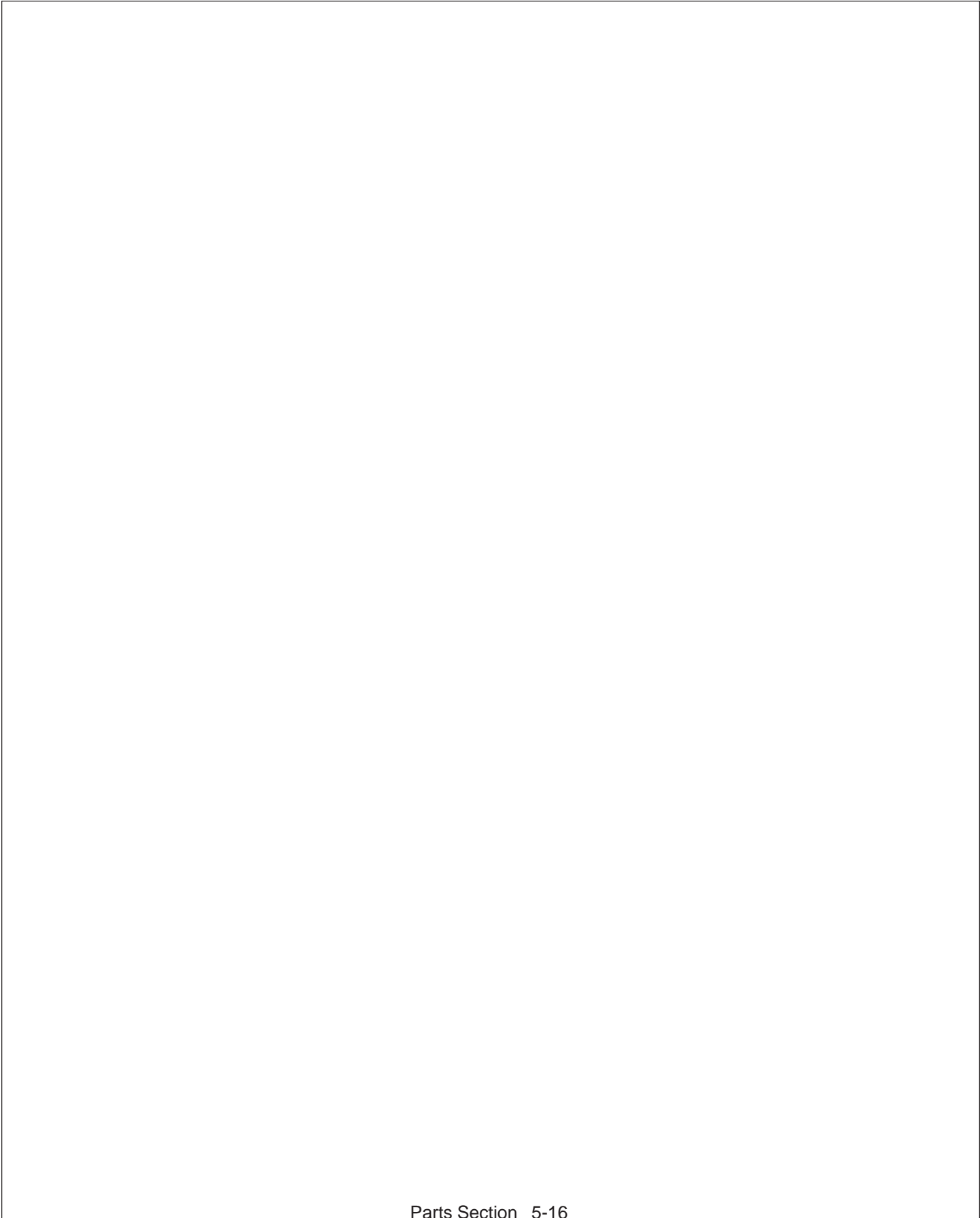

TWIN ROTARY COMMON SECTION

COMMON PARTS SECTION

TABLE OF CONTENTS

| SECTION | ASSEMBLY | PAGE |
|---------------------------------------|-----------------|-------------|
| REAR ROTARY DECK ASSEMBLY | | 6-4 |
| TRAILKAT® REAR ROTARY DECK ASSY | | 6-6 |
| REAR RTRY CASTER WHEEL & 3PT ASSEMBLY | | 6-8 |
| REAR ROTARY HYDRAULICS | | 6-10 |
| ROTARY MOTORS | | 6-12 |
| TWIN PUMP | | 6-14 |
| HUSCO VALVES | | 6-16 |
| COOLER ASSEMBLY | | 6-24 |
| SAFETY STAND | | 6-26 |
| CASTER WHEEL ASSEMBLY | | 6-27 |
| BRAKE VALVE WITH METRIPAK | | 6-28 |
| SWITCHBOX SCHEMATIC | | 6-29 |

PARTS ORDERING GUIDE

The following instructions are offered to help eliminate needless delay and error in processing purchase orders for the equipment in this manual.

1. The Parts Section is prepared in logical sequence and grouping of parts that belong to the basic machine featured in this manual. Part Numbers and Descriptions are given to help locate the parts and quantities required.

2. The Purchase Order must indicate the **Name and Address** of the person or organization ordering the parts, **who should be charged**, and if possible, the **serial number of the machine** for which the parts are being ordered.

3. The purchase order must clearly list the **quantity of each part**, the complete and correct **part number**, and the basic **name of the part**.

4. The manufacturer reserves the right to substitute parts where applicable.

5. Some parts may be unlisted items which are special production items not normally stocked and are subject to special handling. Request a quotation for such parts before sending a purchase order.

6. The manufacturer reserves the right to change prices without prior notice.

NOTE: When ordering replacement decals, refer to the part numbers and descriptions listed in the safety section in the front of this manual.



1000

For maximum safety and to guarantee optimum product reliability, always use genuine **Tiger** replacement parts. The use of inferior replacement parts may cause premature or catastrophic failure which could result in serious injury or death.

Direct any questions regarding parts to:

Tiger Corporation
3301 N. Louise Ave.
Sioux Falls, SD 57107
1-800-843-6849
1-605-336-7900

REAR ROTARY DECK ASSEMBLY

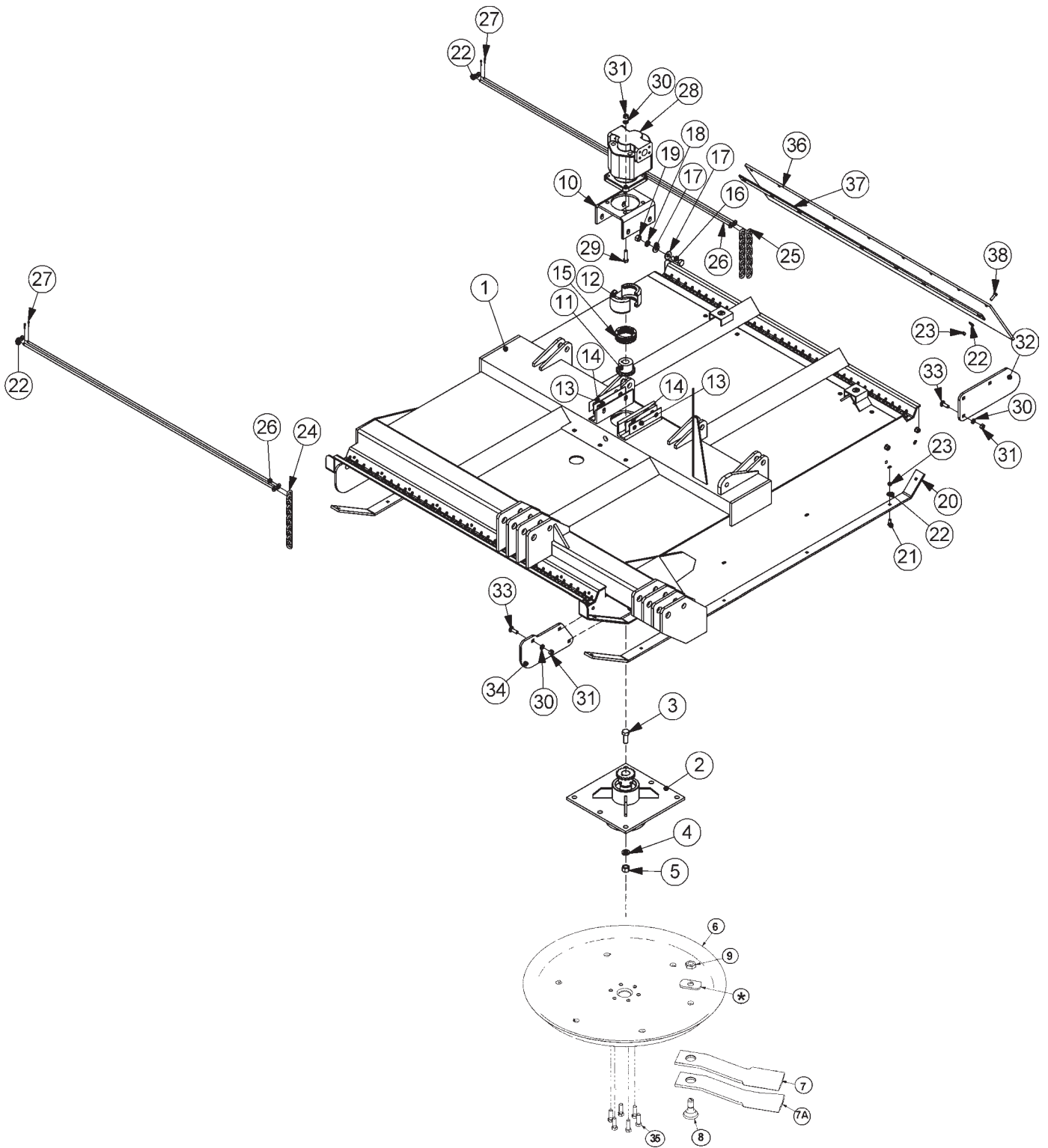

REAR ROTARY DECK ASSEMBLY

| ITEM | PART NO. | QTY. | DESCRIPTION |
|------|-----------------------------------|----------|--|
| ** | 23003 | REF. | REAR RTRY, 60" W/REAR CHAINS |
| 1 | 32616 | 1 | RTRY, 60" DECK, TRR |
| 2 | 6T1024H5 | 1 | SPINDLE ASSY,CPLT,HD,5/8 HOLES |
| 3 | 6T2277 | 6 | CAPSCREW, 3/4" x 2" NF |
| 4 | 21993 | 6 | LOCKWASHER,3/4",GR 8 |
| 5 | 6T2413 | 6 | HEX NUT,3/4,NF,GR 8 |
| 6 | SEE DISK AND KNIVES ASSEMBLY PAGE | | |
| * | SEE DISK AND KNIVES ASSEMBLY PAGE | | |
| 7 | SEE DISK AND KNIVES ASSEMBLY PAGE | | |
| 7A | SEE DISK AND KNIVES ASSEMBLY PAGE | | |
| 8 | SEE DISK AND KNIVES ASSEMBLY PAGE | | |
| 9 | SEE DISK AND KNIVES ASSEMBLY PAGE | | |
| 10 | 6T1001 | 1 | BRKT, MOTOR MTG, 60"SIDE RTRY |
| 11 | 21223 | 1 | SPROKET, 1-1/4" BORE |
| 12 | 6T1033 | 1 | COVER, COUPLING |
| 13 | 6T0822 | 2 | SHIM, MOTOR MOUNT, 14GA. (AS NEEDED) |
| 14 | 6T0822A | 2 | SHIM, MOTOR MOUNT, 18 GA. (AS NEEDED) |
| 15 | 6T1029 | 1 | CHAIN, COUPLING |
| 16 | 21783 | 4 | CAPSCREW, 5/8 x 2,NC |
| 17 | 25270 | 8 | FLATWASHER,5/8", GR 8 |
| 18 | 21992 | 10 | LOCKWASHER, 5/8 |
| 19 | 21775 | 4 | HEX NUT, 5/8 |
| 20 | 23160A | 2 | SKID SHOE |
| 21 | 6T2270 | 12 | PLOW BOLT,3/8" X 1" NC |
| +22 | 22016 | 21 | FLATWASHER,3/8" |
| +23 | 21625 | 21 | HEX NUT,3/8",NC |
| +24 | 22993 | 71 | CHAIN, 5/16" GR30, 9 LINK |
| +25 | 22992 | 71 | CHAIN, 5/16" GR30, 10 LINK |
| +26 | 22054 | 4 | ROD, CHAIN HOLDER |
| +27 | 6T3028 | 4 | COTTER PIN, 1/8" x 1" |
| 28 | 06504011 | 1 | CURRENT MOTOR, (M365 - 2" GEAR) |
| 29 | 21733 | 4 | CAPSCREW, 1/2 x 2,NC |
| 30 | 21990 | 16 | LOCKWASHER, 1/2" |
| 31 | 21725 | 16 | HEX NUT, 1/2" NC |
| 32 | 33656 | 2 | PLATE, GUARD, SAFETY, REAR, RTRY |
| 33 | 6T2267 | 12 | CARRIAGE BOLT, 1/2" x 2" NF, GR8 |
| 34 | 33655 | 2 | PLATE, GAURD, SAFETY, FRONT, RTRY |
| 35 | 6T2290 | 6 | CAPSCREW, 5/8x2, NF GR 8 |
| 36 | 24347 | 1 | REAR DEFLECTOR FLAP |
| 37 | 24349 | 1 | FLAP MOUNTING BAR |
| 38 | 21631 | 9 | CAPSCREW, 3/8" x 1-1/4" NC |

+ REAR CHAIN GAURDS ARE OPTIONAL, QUANTITIES MAY VARY

TRAILKAT® REAR ROTARY DECK ASSY

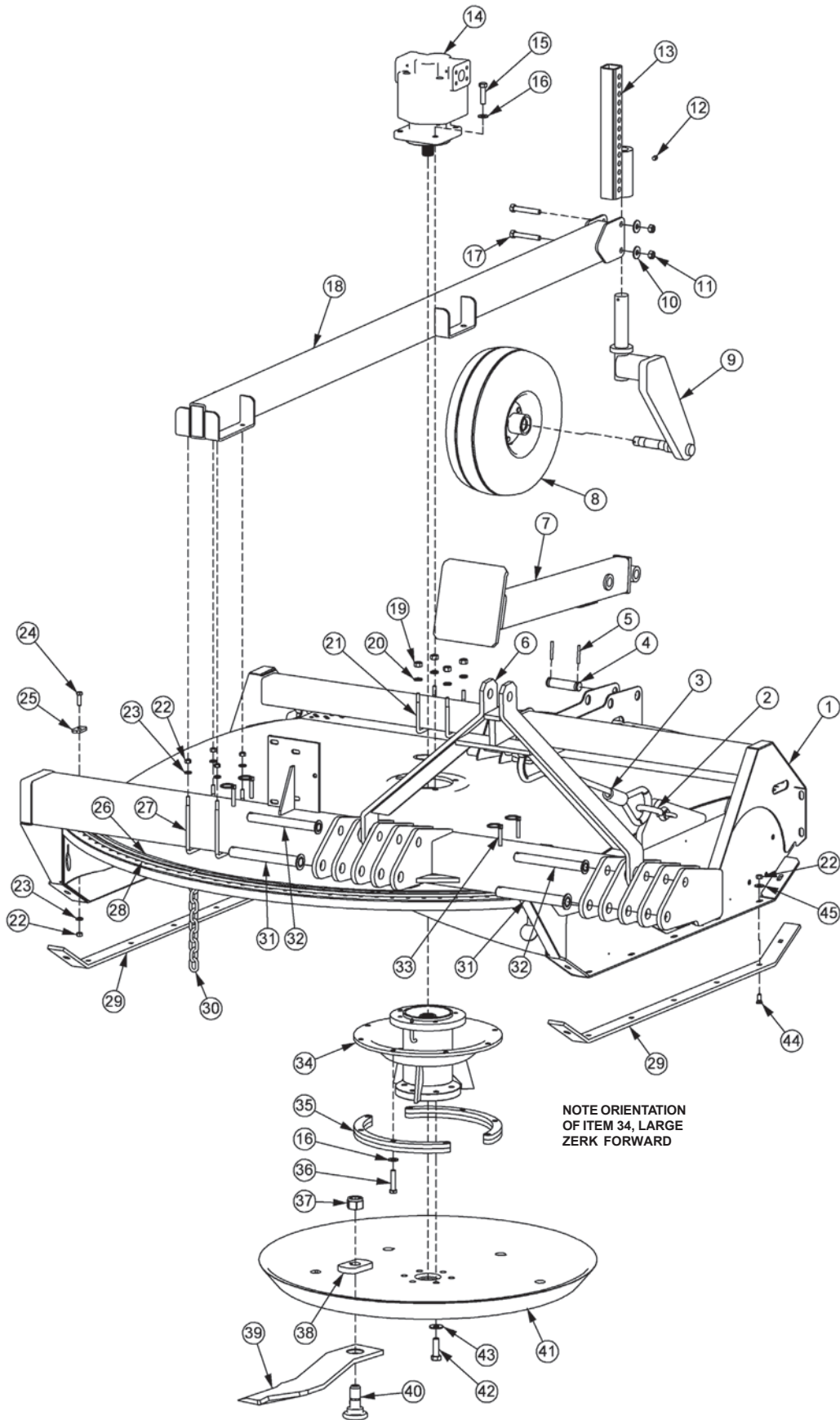

TRAILKAT® REAR ROTARY DECK ASSY

| ITEM | PART NO. | QTY. | DESCRIPTION |
|------|-------------------------------|------|---------------------------------|
| 1 | 06320002 | 1 | TRAILKAT®,60,WLDMNT |
| 2 | 6T0112 | 2 | SHACKLE,W/PIN,CPLT |
| 3 | 22051 | 1 | CABLE,LIFT,TRR,60 |
| 4 | TB1033 | 2 | PIN,CLEVIS,1 x 4 |
| 5 | 06537021 | 4 | ROLLPIN,5mm x 50mm,SS |
| 6 | 21474A | 1 | HITCH,3PT,TRR |
| 7 | 28511 | 1 | STAND,SAFETY SUPPORT W/PAD |
| 8 | 23329 | 1 | CASTER WHL,SOLID TIRE W/SPIND |
| 9 | 22057 | 1 | SPINDLE,CASTER AXLE,ASSY |
| 10 | 22018 | 2 | FLATWASHER,1/2,WIDE |
| 11 | 21725 | 2 | HEX NUT,1/2,NC |
| 12 | 6T3211 | 1 | GREASE ZERK,1/8 |
| 13 | 06370003 | 1 | CASTER ADJ,TRAILKAT |
| 14 | 06504016 | 1 | MOTOR,M365-1 1/4",SPLINE,SEALED |
| 15 | 6T1025 | 4 | CAPSCREW,1/2 x 2,NC,GR8 |
| 16 | 06533004 | 12 | FLATWASHER,1/2,SAE,GR8 |
| 17 | 21738 | 2 | CAPSCREW,1/2 x 3-1/4,NC |
| 18 | 06370004 | 1 | CASTER MNT,TRAILKAT |
| 19 | 21700 | 4 | HEX NUT,1/2,NF |
| 20 | 21990 | 4 | LOCKWASHER,1/2 |
| 21 | 06420003 | 2 | U-BOLT,.50 x 3.25 x 5.00 |
| 22 | 21625 | 22 | HEX NUT,3/8,NC |
| 23 | 21988 | 8 | LOCKWASHER,3/8 |
| 24 | 21631 | 4 | CAPSCREW,3/8 x 1-1/4,NC,GR8 |
| 25 | 34972 | 4 | PLATE,CAP,CHAIN |
| 26 | 34974 | 2 | ROD,CHAIN,INNER,TM60 |
| 27 | 06420005 | 2 | U-BOLT,.38 x 5.63 x 6.31 |
| 28 | 34973 | 2 | ROD,CHAIN,OUTER,TM60 |
| 29 | 06410254 | 2 | SKID SHOE,TSR |
| 30 | 22992 | 156 | CHAIN,10 LINK |
| 31 | 33698 | 2 | PIN,1.13 x 9.00 |
| 32 | 33699 | 2 | PIN,1 x 8.88 |
| 33 | TF1143 | 4 | LYNCH PIN |
| 34 | 34980 | 1 | SPINDLE ASSY,TM60 |
| 35 | 06320011 | 2 | SPACER,TSR,SPINDLE |
| 36 | 06530221 | 8 | CAPSCREW,1/2 x 2-1/4,NF,GR8 |
| 37 | SEE ROTARY KNIVES & DISC PAGE | | |
| 38 | SEE ROTARY KNIVES & DISC PAGE | | |
| 39 | SEE ROTARY KNIVES & DISC PAGE | | |
| 40 | SEE ROTARY KNIVES & DISC PAGE | | |
| 41 | SEE ROTARY KNIVES & DISC PAGE | | |
| 42 | 6T2290 | 6 | CAPSCREW,5/8 x 2,NF,GR8 |
| 43 | 25270 | 6 | FLATWASHER,5/8,USS,GR8 |
| 44 | 6T2270 | 14 | PLOW BOLT,3/8 x 1,NC |
| 45 | 22016 | 14 | FLATWASHER,3/8,GR8 |

REAR ROTARY CASTER WHEEL & 3PT ASSEMBLY

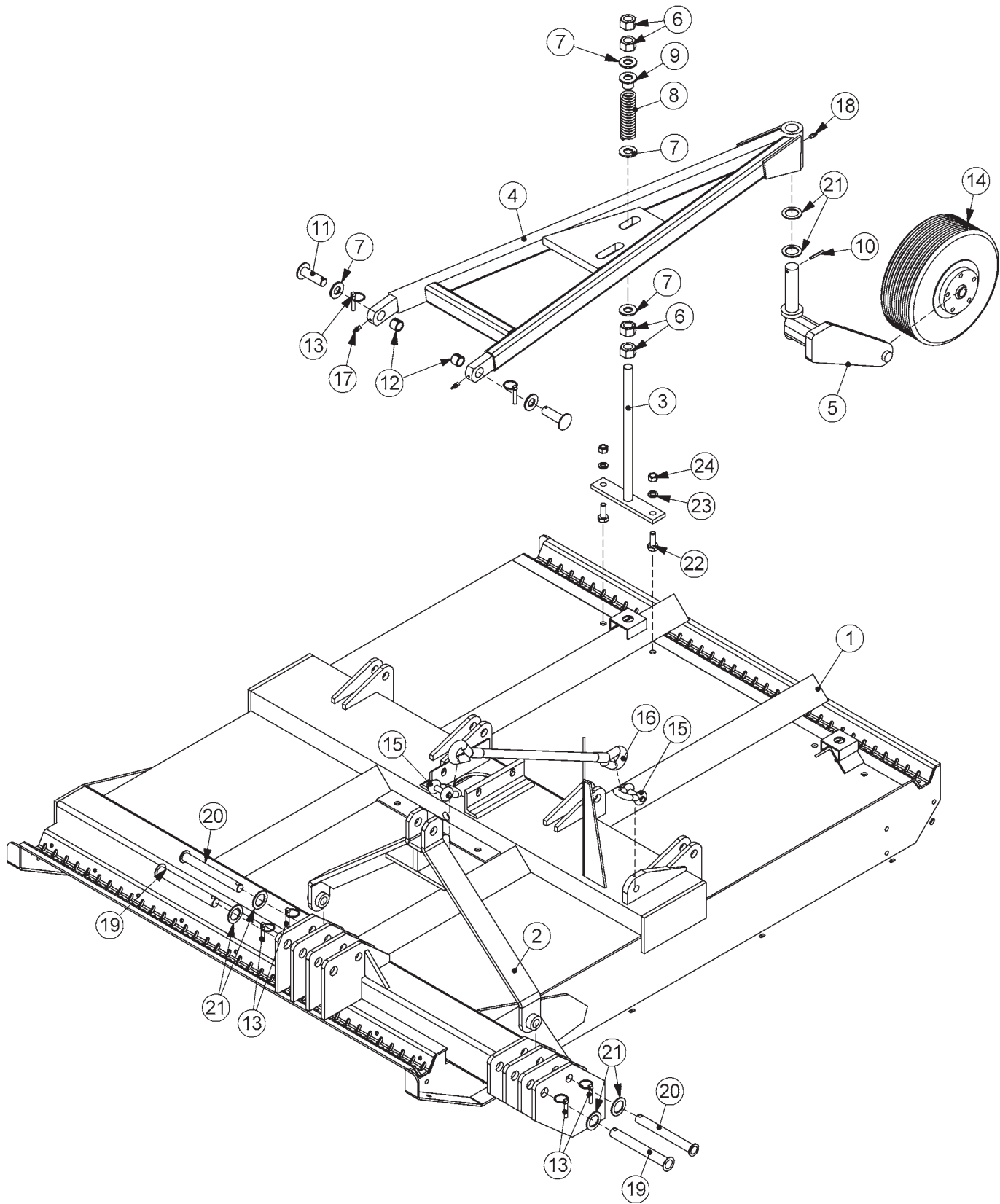

23003 3PT & CASTER

Twin Rotary Common Section 6-8

REAR ROTARY CASTER WHEEL & 3PT ASSEMBLY

| ITEM | PART NO. | QTY. | DESCRIPTION |
|------|----------|-------|---------------------------------|
| 1 | 32616 | 1 | RTRY, 60" DECK, TRR |
| 2 | 21474A | 1 | HITCH, 3PT, TRR |
| 3 | 22059B | 1 | ADJ ROD, TRR |
| 4 | 25095A | 1 | FRAME, CASTER WHEEL, TRR 60" |
| 5 | 22057 | 1 | SPINDLE, CASTER AXLE, ASSY |
| 6 | 21925 | 4 | HEX NUT, 1" NC |
| 7 | 22023 | 5 | FLATWASHER, 1" |
| 8 | 22058 | 1 | SPRING, REAR RTRY |
| 9 | 22753 | 1 | TUBE, PROTECTOR |
| 10 | 6T3014 | 1 | ROLL PIN, 1/4" x 2" |
| 11 | 22060 | 2 | CASTER FRAME PIN |
| 12 | TB3010 | 2 | BUSHING, 1" |
| 13 | TF1143 | 6 | PIN, LYNCH, 7/16" x 2" |
| 14 | 28548 | 1 | CASTER WHEEL, SOLID TIRE |
| ** | 22065 | 1 | HUB ASSY, REAR ROTARY |
| ** | 22066 | 1 | HUB, CASTER (REAR ROTARY) |
| ** | 22070 | 1 | DUST CAP |
| ** | 22071 | 5 | HUB STUD |
| ** | 22073 | 1 | HEX NUT, 1"NF (SLOTTED) |
| ** | 22533 | 1 | COTTER PIN, 3/16" x 2" |
| ** | 6T0830 | 2 | BEARING, CONE, CASTER WHEEL |
| ** | 6T0838 | 1 | SEAL |
| ** | 23329 | 1 | WHEEL, CPLT, SOLID TIRE |
| ** | 21416 | 1 | TIRE, SOLID, RR-RTRY |
| ** | 22697 | 1 | RIM, OUTER/RR RTRY CASTER |
| ** | 22696 | 1 | RIM, REAR ROTARY CASTER |
| 15 | 6T0112 | 2 | SHACKLE, W/PIN, CPLT |
| 16 | 22051 | 1 | CABLE, LIFT, TRR, 60" |
| 17 | 6T3207 | 2 | GREASE ZERK, 1/4" X STR |
| 18 | 6T3211 | 1 | GREASE ZERK, 1/8" X STR |
| 19 | 33698 | 2 | PIN, CAPPED, 1-1/8" x 9" |
| 20 | 33699 | 2 | PIN, CAPPED, 1" x 9" |
| 21 | 6T2617 | 6 | BUSHING, MACH, 1-1/2IDX 2-1/4OD |
| 22 | 21782 | 2 | CAPSCREW, 5/8 x 1 3/4, NC |
| 23 | 21992 | 2 | LOCKWASHER, 5/8 |
| | 24 | 21775 | 2 HEX NUT, 5/8 |

** - NOT SHOWN

REAR ROTARY HYDRAULICS

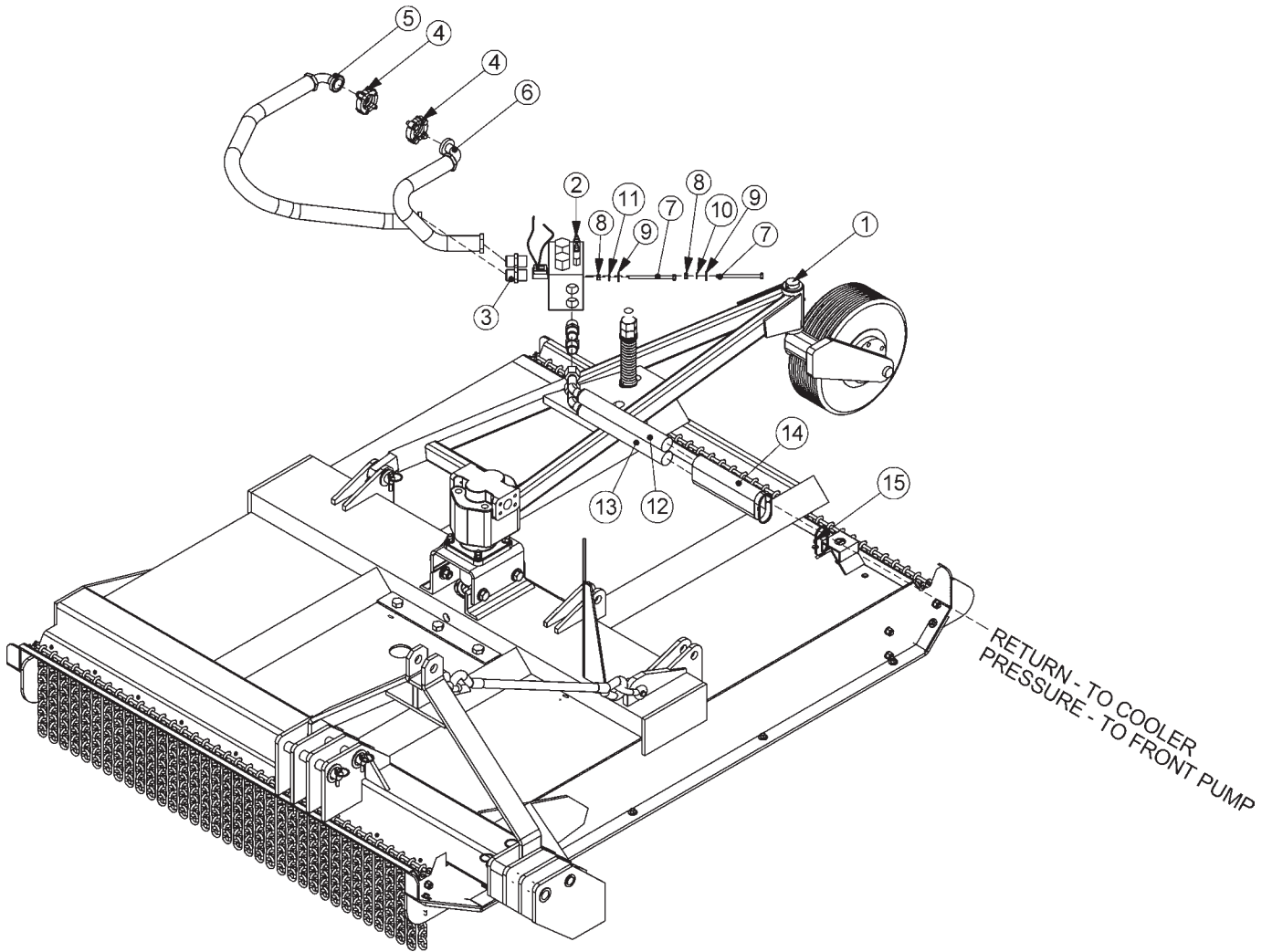

06100906

REAR ROTARY HYDRAULICS

| ITEM | PART NO. | QTY. | DESCRIPTION |
|------|----------|------|----------------------------------|
| 1 | 23003 | 1 | REAR RTRY, 60"W/REAR CHAINS |
| 1 | 30806 | 1 | RTRY, 60" CPLT - HP (W/FBAR) TRR |
| 2 | 06510083 | 1 | VALVE,BRAKE,SOL,3000PSI,METRI |
| 3 | 33555 | 4 | ADAPTER,1MORB x 1MJIC |
| 4 | TF4852 | 2 | KIT, FLANGE, #20 |
| 5 | 34198 | 1 | HOSE, 1" x 40" (1FJX x 20FLG90) |
| 6 | 34197 | 1 | HOSE, 1" x 33" (1FJX x 20FLG90) |
| 7 | 21644 | 2 | CAPSCREW,3/8" X 5" NC |
| 8 | 21625 | 2 | HEX NUT,3/8",NC |
| 9 | 22016 | 2 | FLATWASHER,3/8" |
| 10 | 21988 | 1 | LOCKWASHER, 3/8" |
| 11 | 6T2665 | 1 | STAR LOCKWASHER, 3/8" |
| 12 | 34192 | 1 | HOSE, 1" x 185" (1MP x 1FJX45) |
| 13 | 34193 | 1 | HOSE, 1" x 65" (1FJX45 x 1FJX45) |
| 14 | 33930 | 1 | HOSE SLEEVE, TRR |
| 15 | 6T1823 | 2 | ZIP TIE, 14" STRAPS |

60" ROTARY MOTOR

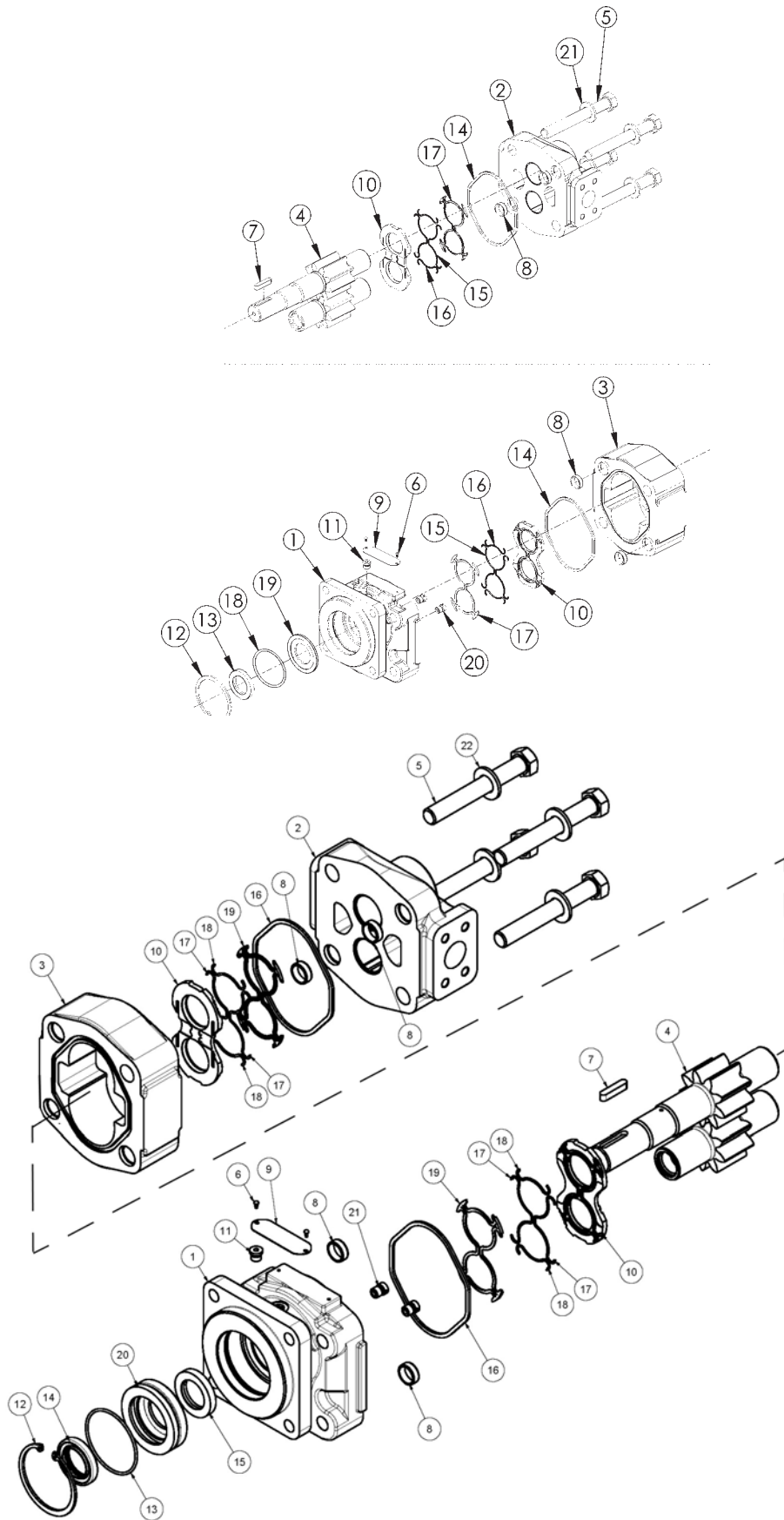

Twin Rotary Common Section 6-12

60" ROTARY MOTOR

| ITEM | PART NO. | QTY. | DESCRIPTION |
|------|-----------------|--------------|--|
| * | 06504016 | AVAIL | MOTOR ASSEMBLY 1 1/4" COMPLETE TSR/TRAILKAT |
| 1 | 22790 | 1 | SHAFT END COVER |
| 2 | 06504025 | 1 | PORT END COVER |
| 3 | 02962194 | 1 | GEAR HOUSING |
| 4 | 06504053 | 1 | MATCHED GEAR SET |
| 5 | 02962197 | 4 | CAP SCREW |
| 6 | 06504027 | 2 | SET SCREW |
| 7 | 06504028 | 1 | KEY |
| 8 | 02962201 | 4 | DOWEL PIN |
| 9 | | 1 | NAMEPLATE |
| 10 | 06504029 | 2 | THRUSTPLATE |
| 11 | 02961940 | 1 | HEX PLUG |
| 12 | 6T5200 | 1 | SNAP RING |
| 13 | 06504030 | 1 | LIP SEAL (INCLUDED IN SEAL KIT) |
| 14 | 22797 | 2 | GASKET SEAL (INCLUDED IN SEAL KIT) |
| 15 | 06504031 | 4 | SIDE SEAL (INCLUDED IN SEAL KIT) |
| 16 | 06504032 | 4 | END SEAL (INCLUDED IN SEAL KIT) |
| 17 | 06504033 | 2 | BACK-UP SEAL (INCLUDED IN SEAL KIT) |
| 18 | 06504034 | 1 | SPACER |
| 19 | 06504035 | 1 | SEAL RETAINER |
| 20 | 22791 | 2 | CHECK ASSEMBLY |
| 21 | 06504036 | 4 | WASHER |
| * | 06504023 | AVAIL | SEAL KIT (INCLUDES 13, 14, 15, 16 AND 17) |

| ITEM | PART NO. | QTY. | DESCRIPTION |
|------|-----------------|--------------|---|
| * | 06504011 | AVAIL | MOTOR ASSEMBLY 2 1/4" COMPLETE TRB60 |
| | 06504103 | 1 | SEAL KIT |
| 1 | 22790 | 1 | HOUSING, SEC |
| 2 | 06504088 | 1 | HOUSING, PEC |
| 3 | 06504062 | 1 | HOUSING, GEAR |
| 4 | 06504090 | 1 | SET, GEAR SHAFT |
| 5 | 06504104 | 4 | CAP SCREW |
| 6 | 06504078 | 2 | SCREW, DRIVE |
| 7 | 06504092 | 1 | KEY |
| 8 | 06504093 | 4 | PIN, DOWEL |
| 9 | 06504094 | 1 | NAME PLATE |
| 10 | 06504095 | 2 | THRPL |
| 11 | 02961940 | 1 | PLUG, ODT |
| 12 | 02962200 | 1 | RING, SNAP |
| 13 | 06504096 | 1 | O RING |
| 14 | 6T5101 | 1 | SEAL, LIP |
| 15 | 06504097 | 1 | SEAL, LIP |
| 16 | 22797 | 2 | SEAL, SQ-R |
| 17 | 06504098 | 4 | SEAL, SIDE CHAN |
| 18 | 06504099 | 4 | SEAL, END CHAN |
| 19 | 06504100 | 2 | SEAL, BK-UP |
| 20 | 06504101 | 1 | RTNR, SEAL |
| 21 | 6T5809 | 2 | CHECK ASS'Y |
| 22 | 06504102 | 4 | WASHER |

PUMP - SERVICE PARTS (06504002)

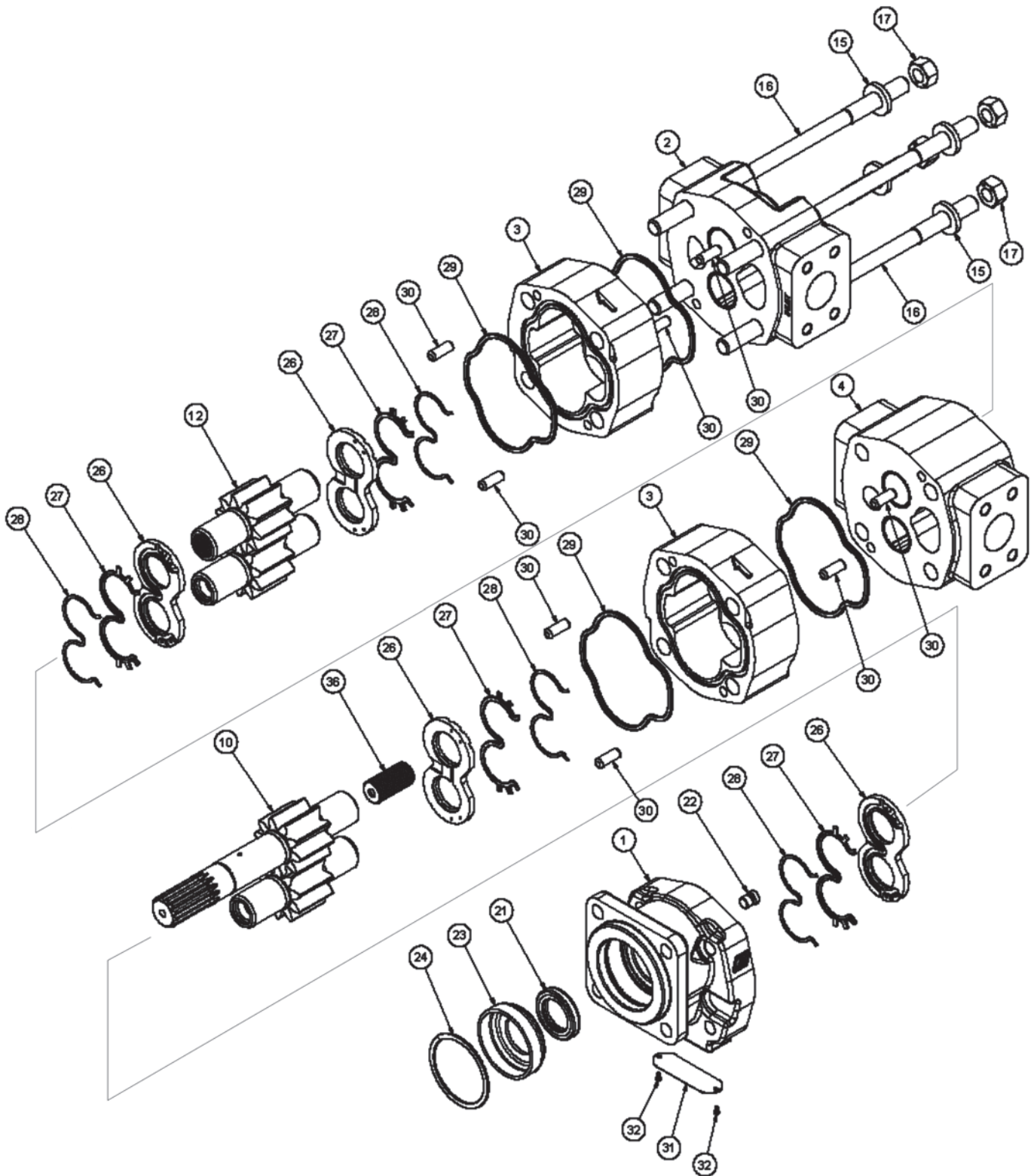

PUMP - SERVICE PARTS (06504002)

| ITEM | P/N | QTY. | DESCRIPTION |
|------|---------------------------|------|------------------------|
| 1 | 22766 | 1 | HOUSING,SEC |
| 2 | 06504068 | 1 | HOUSING,PEC |
| 3 | 02965092 | 2 | HOUSING,GEAR |
| 4 | 06504069 | 1 | HOUSING,BEARINGCARRIER |
| 10 | 06504070 | 1 | SET,GEARSHAFT |
| 12 | 06504071 | 1 | GEAR,SET |
| 15 | 02961917 | 4 | WASHER |
| 16 | 06504072 | 4 | STUD |
| 17 | 06504073 | 4 | NUT,HEX |
| 21 | * 22765 (SEE SEAL KIT) | 1 | SEAL,LIP |
| 22 | 6T5121 | 1 | PLUG |
| 23 | 02979970 | 1 | SPACER |
| 24 | 02979971 | 1 | RING,SNAP |
| 26 | 02965611 | 4 | THRPL |
| 27 | * 06504074 (SEE SEAL KIT) | 4 | SEAL,CHAN |
| 28 | * 06504075 (SEE SEAL KIT) | 4 | SEAL,BK-UP |
| 29 | * 06504076 (SEE SEAL KIT) | 4 | SEAL,SQ-R |
| 30 | 02961924 | 8 | PIN,DOWEL |
| 31 | 06504077 | 1 | NAMEPLATE |
| 32 | 06504078 | 2 | SCREW,DRIVE |
| 36 | 06504079 | 1 | SFT,CONN |
| | * 22764 | 1 | SEAL KIT |

2 SP HUSCO - LOAD SENSE (31320)

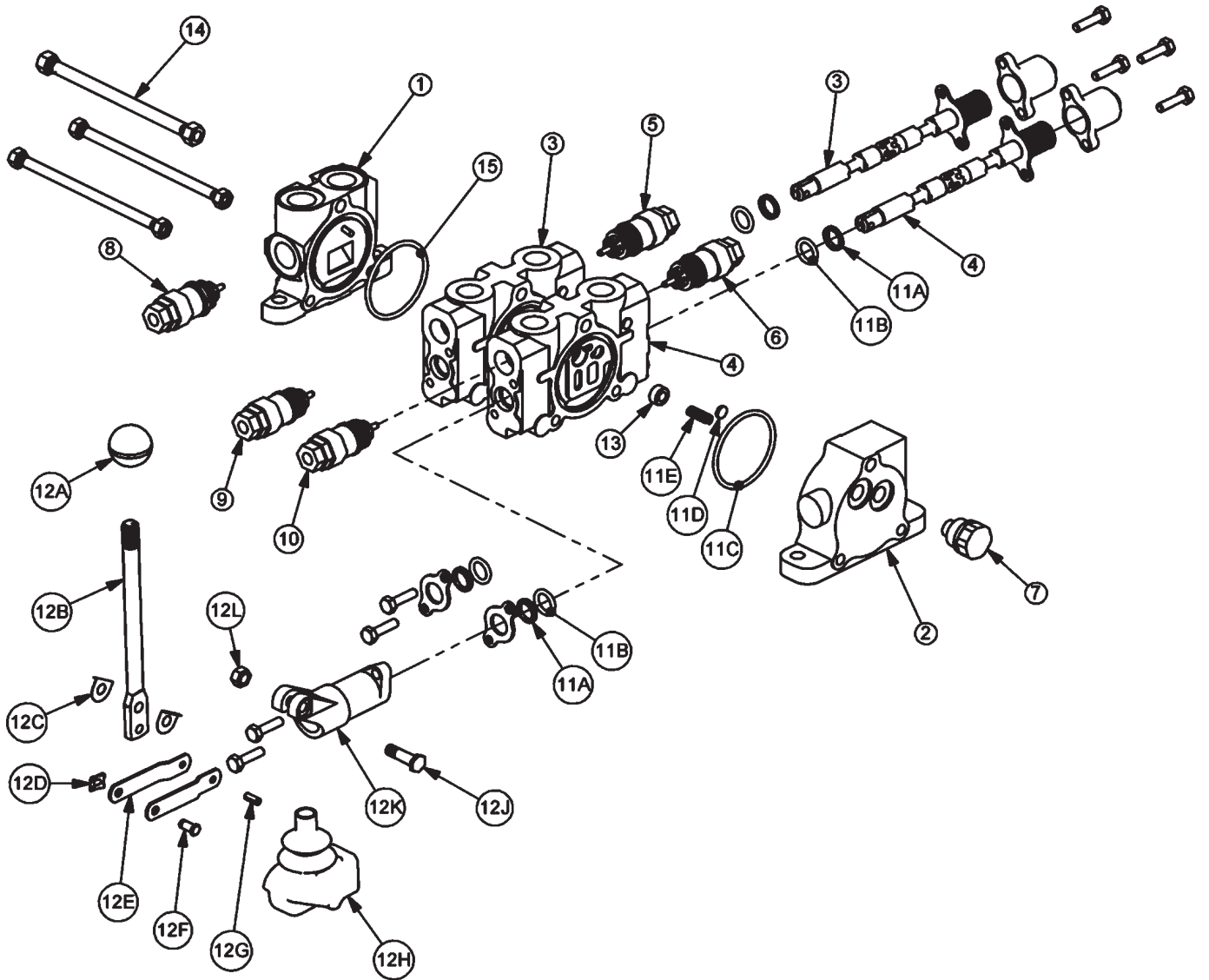

2 SP HUSCO - LOAD SENSE (31320)

| ITEM | PART NO. | QTY | DESCRIPTION |
|------|----------|-----|--|
| 1 | 31595 | 1 | INLET END COVER |
| 2 | 31594 | 1 | END COVER, LOAD SENSE |
| 3 | 31597 | 1 | VALVE SECTION (DOUBLE ACTING, CENTER SPRING) |
| 4 | 31597 | 1 | VALVE SECTION (DOUBLE ACTING, CENTER SPRING) |
| 5 | 06503067 | 1 | RELIEF PLUG |
| 6 | 06503067 | 1 | RELIEF PLUG |
| 7 | N/A | - | N/A |
| 8 | 6T4209 | 1 | RELIEF PLUG |
| 9 | 31862 | 1 | RELIEF VALVE, 2175 PSI |
| 10 | 31862 | 1 | RELIEF VALVE, 2175 PSI |
| 11 | 31593 | 2 | VALVE SEAL KIT (FOR ONE SECTION) |
| 11A | | 2 | WIPER |
| 11B | | 2 | O-RING SMALL |
| 11C | | 1 | O-RING LARGE |
| 11D | | 1 | SHUTTLE DISC |
| 11E | | 1 | SPRING |
| 12 | TB1017L | 2 | LEVER KIT (FOR ONE SECTION) |
| 12A | | 1 | LEVER KNOB |
| 12B | | 1 | LEVER |
| 12C | | 2 | LEVER WASHER |
| 12D | | 1 | LEVER CLIP |
| 12E | | 2 | LINKAGE |
| 12F | | 1 | LEVER PIN |
| 12G | | 1 | ROLL PIN |
| 12H | | 1 | LEVER BOOT |
| 12J | | 1 | LEVER BOLT |
| 12K | | 1 | LEVER DUST COVER |
| 12L | | 1 | LEVER NUT |
| 13 | 31603 | 2 | COMPENSATOR |
| 14 | TB1017X | 1 | TIE ROD KIT |
| 15 | 24214 | 1 | O-RING, LARGE |

2 SP HUSCO - LOAD SENSE (31321)

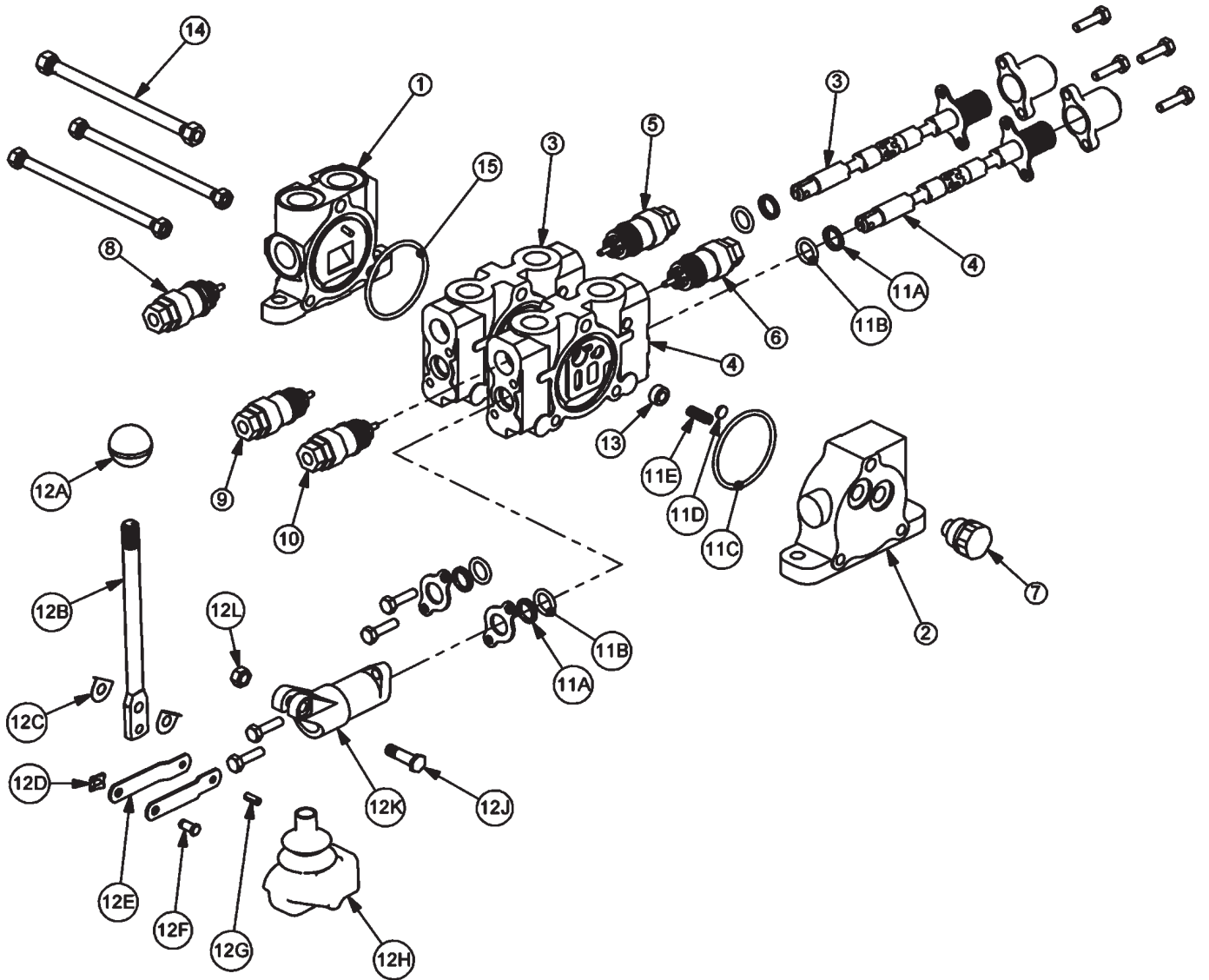

2 SP HUSCO - LOAD SENSE (31321)

| ITEM | PART NO. | QTY | DESCRIPTION |
|------|----------|-----|--|
| 1 | 31595 | 1 | INLET END COVER |
| 2 | 31594 | 1 | END COVER, LOAD SENSE |
| 3 | 31597 | 1 | VALVE SECTION (DOUBLE ACTING, CENTER SPRING) |
| 4 | 31597 | 1 | VALVE SECTION (DOUBLE ACTING, CENTER SPRING) |
| 5 | 06503067 | 1 | RELIEF PLUG |
| 6 | 31861 | 1 | RELIEF VALVE, 360 PSI |
| 7 | N/A | - | N/A |
| 8 | 6T4209 | 1 | RELIEF PLUG |
| 9 | 31862 | 1 | RELIEF VALVE, 2175 PSI |
| 10 | 31862 | 1 | RELIEF VALVE, 2175 PSI |
| 11 | 31593 | 2 | VALVE SEAL KIT (FOR ONE SECTION) |
| 11A | | 2 | WIPER |
| 11B | | 2 | O-RING SMALL |
| 11C | | 1 | O-RING LARGE |
| 11D | | 1 | SHUTTLE DISC |
| 11E | | 1 | SPRING |
| 12 | TB1017L | 2 | LEVER KIT (FOR ONE SECTION) |
| 12A | | 1 | LEVER KNOB |
| 12B | | 1 | LEVER |
| 12C | | 2 | LEVER WASHER |
| 12D | | 1 | LEVER CLIP |
| 12E | | 2 | LINKAGE |
| 12F | | 1 | LEVER PIN |
| 12G | | 1 | ROLL PIN |
| 12H | | 1 | LEVER BOOT |
| 12J | | 1 | LEVER BOLT |
| 12K | | 1 | LEVER DUST COVER |
| 12L | | 1 | LEVER NUT |
| 13 | 31603 | 2 | COMPENSATOR |
| 14 | TB1017X | 1 | TIE ROD KIT |
| 15 | 24214 | 1 | O-RING, LARGE |

3 SP HUSCO - LOAD SENSE CABLE (06502043)

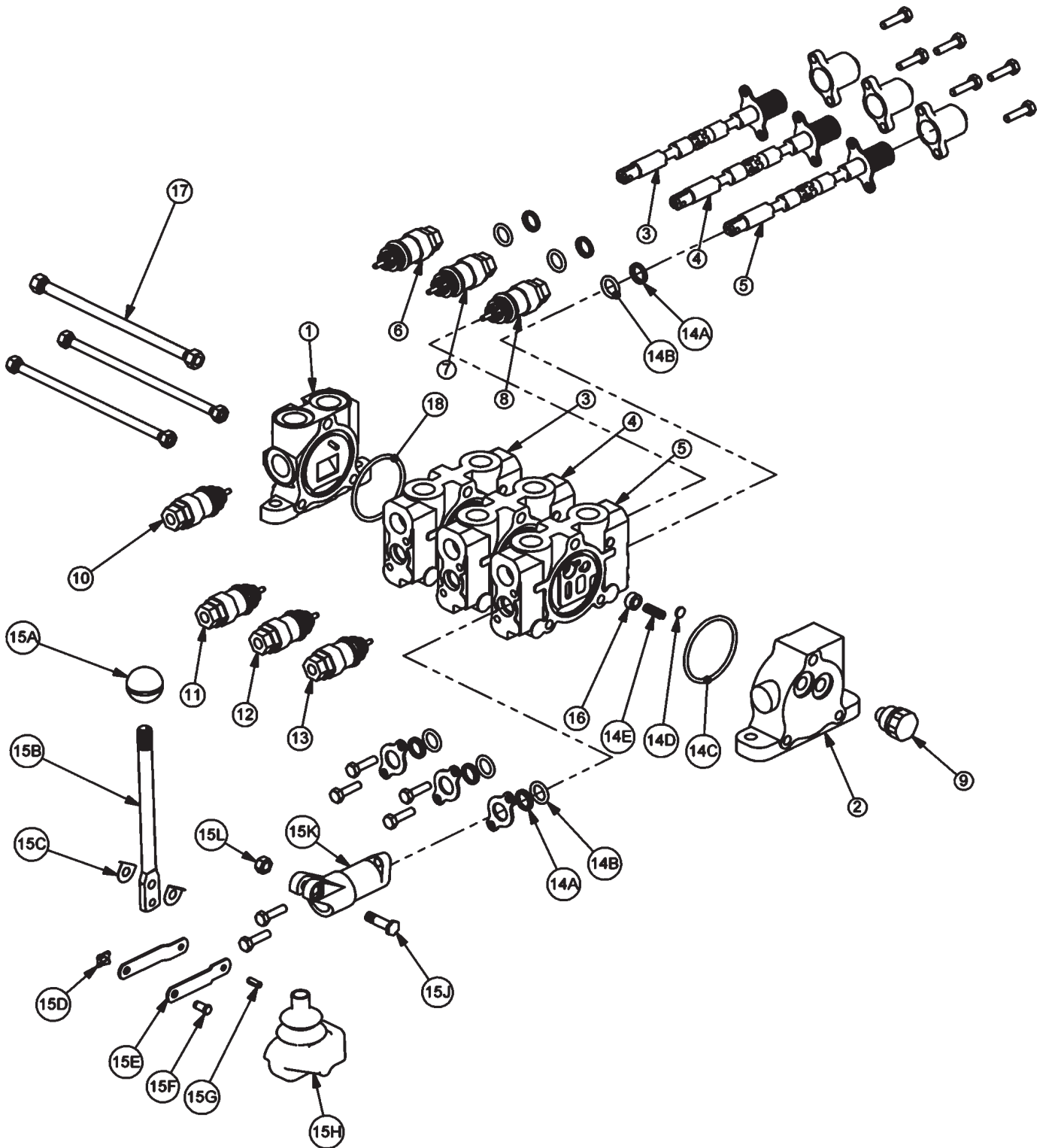

3 SP HUSCO - LOAD SENSE CABLE (06502043)

| ITEM | PART NO. | QTY | DESCRIPTION |
|------|----------|-----|---|
| 1 | 31595 | 1 | INLET END COVER |
| 2 | 31594 | 1 | END COVER, LOAD SENSE |
| 3 | 31597 | 1 | VALVE SECTION (DOUBLE ACTING, CENTER SPRING) |
| 4 | 31597 | 1 | VALVE SECTION (DOUBLE ACTING, CENTER SPRING) |
| 5 | 31597 | 1 | VALVE SECTION (DOUBLE ACTING, CENTER SPRING) (REMOVE SHUTTLE DISC) |
| 6 | 06503067 | 1 | RELIEF PLUG |
| 7 | 06503067 | 1 | RELIEF PLUG |
| 8 | 28816 | 1 | RELIEF VALVE, 1812 PSI |
| 9 | 06503068 | 1 | RELIEF PLUG |
| 10 | 6T4209 | 1 | RELIEF PLUG |
| 11 | 31862 | 1 | RELIEF VALVE, 2175 PSI |
| 12 | 31862 | 1 | RELIEF VALVE, 2175 PSI |
| 13 | 28816 | 1 | RELIEF VALVE, 1812 PSI |
| 14 | 31593 | 3 | VALVE SEAL KIT (FOR ONE SECTION) |
| 14A | | 2 | WIPER |
| 14B | | 2 | O-RING SMALL |
| 14C | | 1 | O-RING LARGE |
| 14D | | 1 | SHUTTLE DISC |
| 14E | | 1 | SPRING |
| 15 | TB1017L | 3 | LEVER KIT (FOR ONE SECTION) |
| 15A | | 1 | LEVER KNOB |
| 15B | | 1 | LEVER |
| 15C | | 2 | LEVER WASHER |
| 15D | | 1 | LEVER CLIP |
| 15E | | 2 | LINKAGE |
| 15F | | 1 | LEVER PIN |
| 15G | | 1 | ROLL PIN |
| 15H | | 1 | LEVER BOOT |
| 15J | | 1 | LEVER BOLT |
| 15K | | 1 | LEVER DUST COVER |
| 15L | | 1 | LEVER NUT |
| 16 | 31603 | 3 | COMPENSATOR |
| 17 | 23397 | 1 | TIE ROD KIT |
| 18 | 24214 | 1 | O-RING, LARGE |

3 SP HUSCO - LOAD SENSE COMBO (06502044)

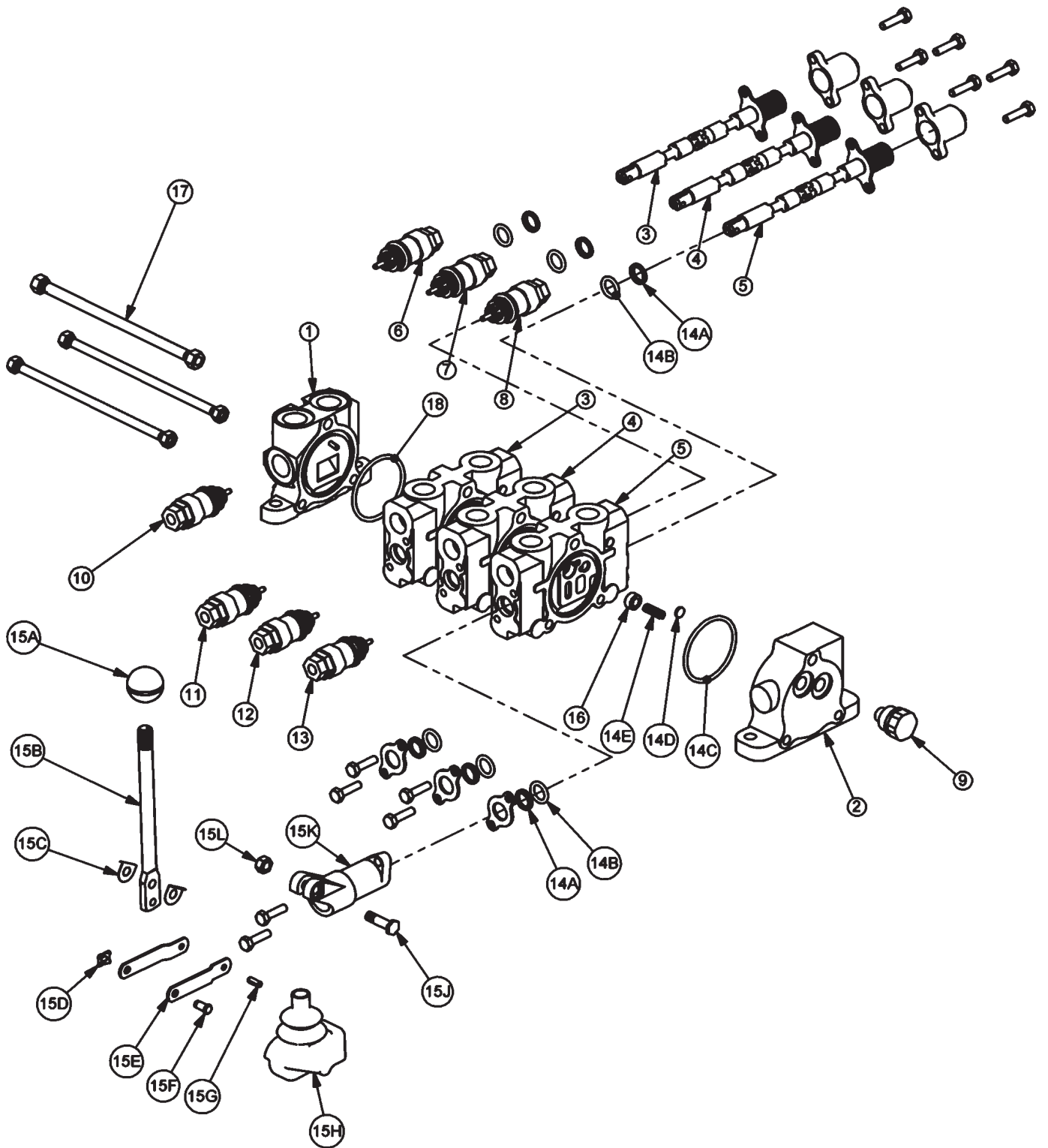

3 SP HUSCO - LOAD SENSE COMBO (06502044)

| ITEM | PART NO. | QTY | DESCRIPTION |
|------|----------|-----|---|
| 1 | 31595 | 1 | INLET END COVER |
| 2 | 31594 | 1 | END COVER, LOAD SENSE |
| 3 | 31597 | 1 | VALVE SECTION (DOUBLE ACTING, CENTER SPRING) |
| 4 | 31597 | 1 | VALVE SECTION (DOUBLE ACTING, CENTER SPRING) |
| 5 | 31597 | 1 | VALVE SECTION (DOUBLE ACTING, CENTER SPRING) (REMOVE SHUTTLE DISC) |
| 6 | 06503067 | 1 | RELIEF PLUG |
| 7 | 31861 | 1 | RELIEF VALVE, 360 PSI |
| 8 | 28816 | 1 | RELIEF VALVE, 1812 PSI |
| 9 | 06503068 | 1 | RELIEF PLUG |
| 10 | 6T4209 | 1 | RELIEF PLUG |
| 11 | 31862 | 1 | RELIEF VALVE, 2175 PSI |
| 12 | 31862 | 1 | RELIEF VALVE, 2175 PSI |
| 13 | 28816 | 1 | RELIEF VALVE, 1812 PSI |
| 14 | 31593 | 3 | VALVE SEAL KIT (FOR ONE SECTION) |
| 14A | | 2 | WIPER |
| 14B | | 2 | O-RING SMALL |
| 14C | | 1 | O-RING LARGE |
| 14D | | 1 | SHUTTLE DISC |
| 14E | | 1 | SPRING |
| 15 | TB1017L | 3 | LEVER KIT (FOR ONE SECTION) |
| 15A | | 1 | LEVER KNOB |
| 15B | | 1 | LEVER |
| 15C | | 2 | LEVER WASHER |
| 15D | | 1 | LEVER CLIP |
| 15E | | 2 | LINKAGE |
| 15F | | 1 | LEVER PIN |
| 15G | | 1 | ROLL PIN |
| 15H | | 1 | LEVER BOOT |
| 15J | | 1 | LEVER BOLT |
| 15K | | 1 | LEVER DUST COVER |
| 15L | | 1 | LEVER NUT |
| 16 | 31603 | 3 | COMPENSATOR |
| 17 | 23397 | 1 | TIE ROD KIT |
| 18 | 24214 | 1 | O-RING, LARGE |

SIDE COOLER

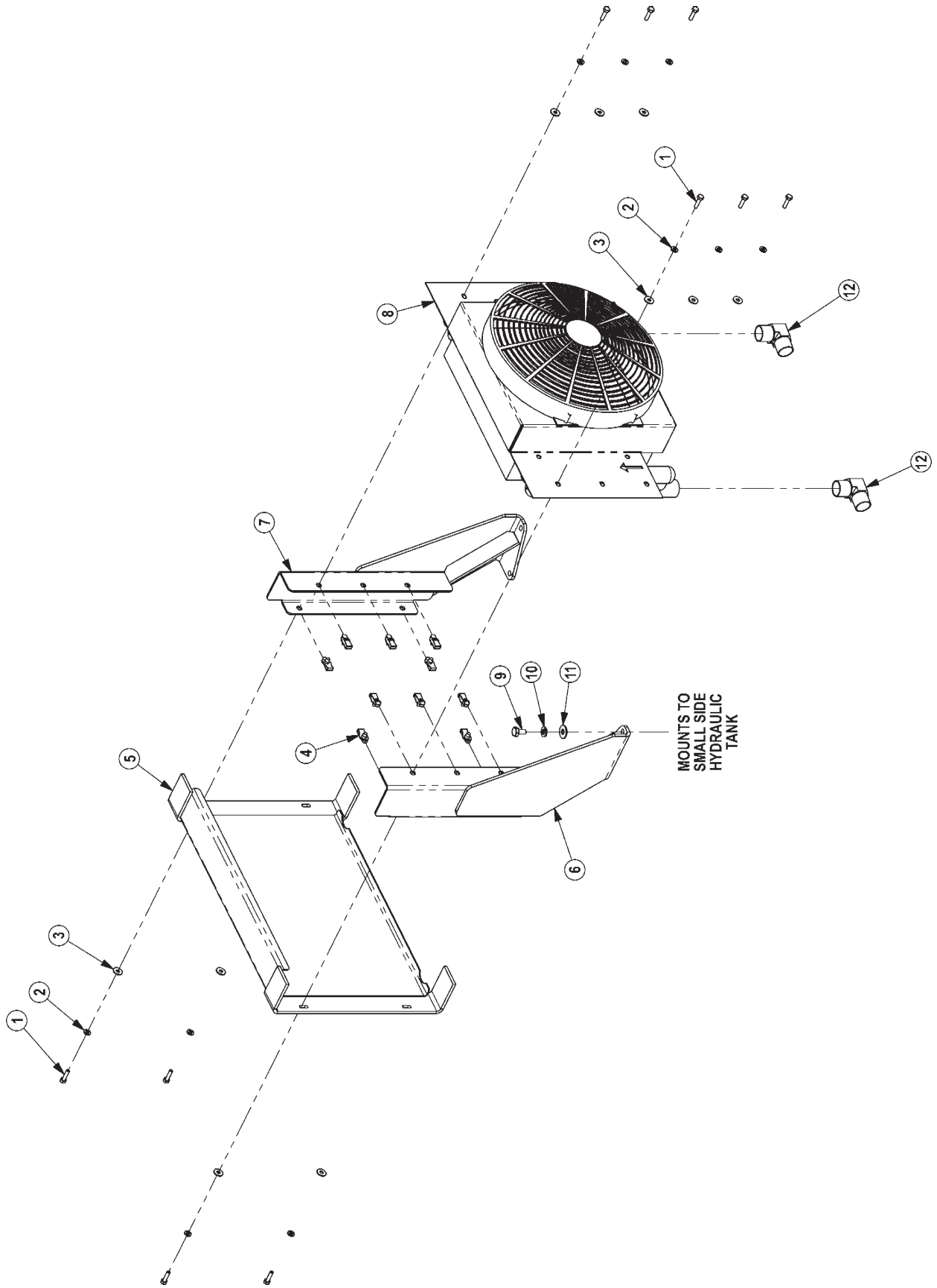

SIDE COOLER

| ITEM | PART NO. | QTY. | DESCRIPTION |
|------|----------|------|---------------------------|
| 1 | 21530 | 10 | CAPSCREW,1/4 X1 NC |
| 2 | 21986 | 10 | LOCKWASHER,1/4 |
| 3 | 22014 | 10 | FLATWASHER,1/4 |
| 4 | 35176 | 10 | 1/4 U-NUT |
| 5 | 06370015 | 1 | SCREEN,COOLER,FRNT |
| 6 | 06380006 | 1 | MNT,COOLER,BUMPER TANK,RH |
| 7 | 06380007 | 1 | MNT,COOLER,BUMPER TANK,LH |
| 8 | 06510026 | 1 | COOLER,FRONT MNT |
| 9 | 21629 | 4 | CAPSCREW,3/8 X 3/4 NC |
| 10 | 21988 | 4 | LOCKWASHER,3/8 |
| 11 | 22016 | 4 | FLATWASHER,3/8 |
| 12 | 34117 | 2 | ELBOW,1MOR X 1MJ90,FORGED |

SAFETY STAND

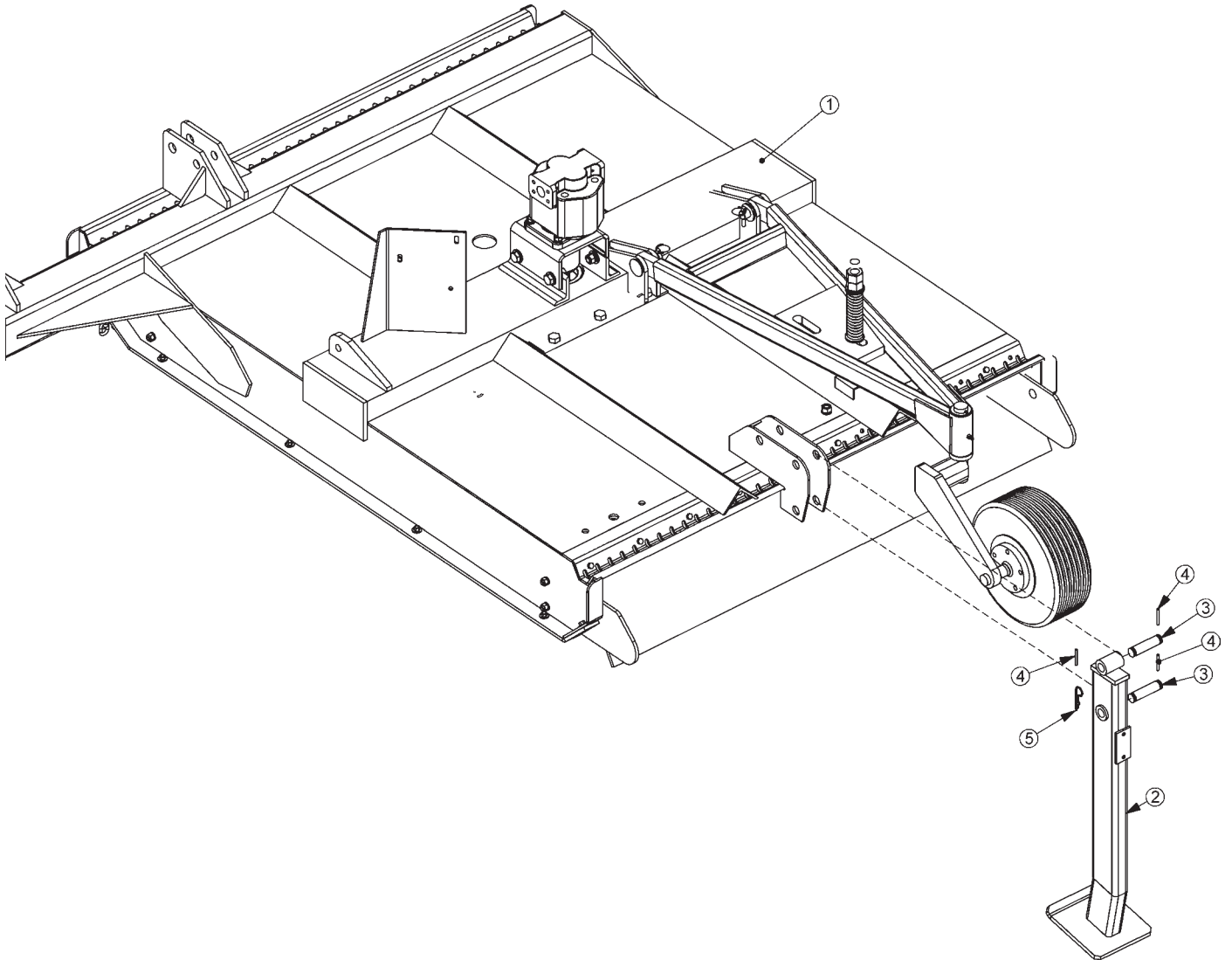

CP23002

| ITEM | PART NO. | QTY. | DESCRIPTION |
|------|----------|------|--|
| 1 | REF. | * | REAR RTRY - REFER TO REAR RTRY DECK ASSY |
| 2 | 28511 | 1 | REAR RTRY STAND |
| 3 | TB1033D | 2 | PIN,CLEVIS 1"X4"(DRILLED7/32) |
| 4 | 6T3014 | 3 | ROLL PIN, 1/4" x 2" |
| 5 | 6T3004 | 1 | R-CLIP (HAIRPIN COTTER, 3/16") |

CASTER WHEEL ASSEMBLY

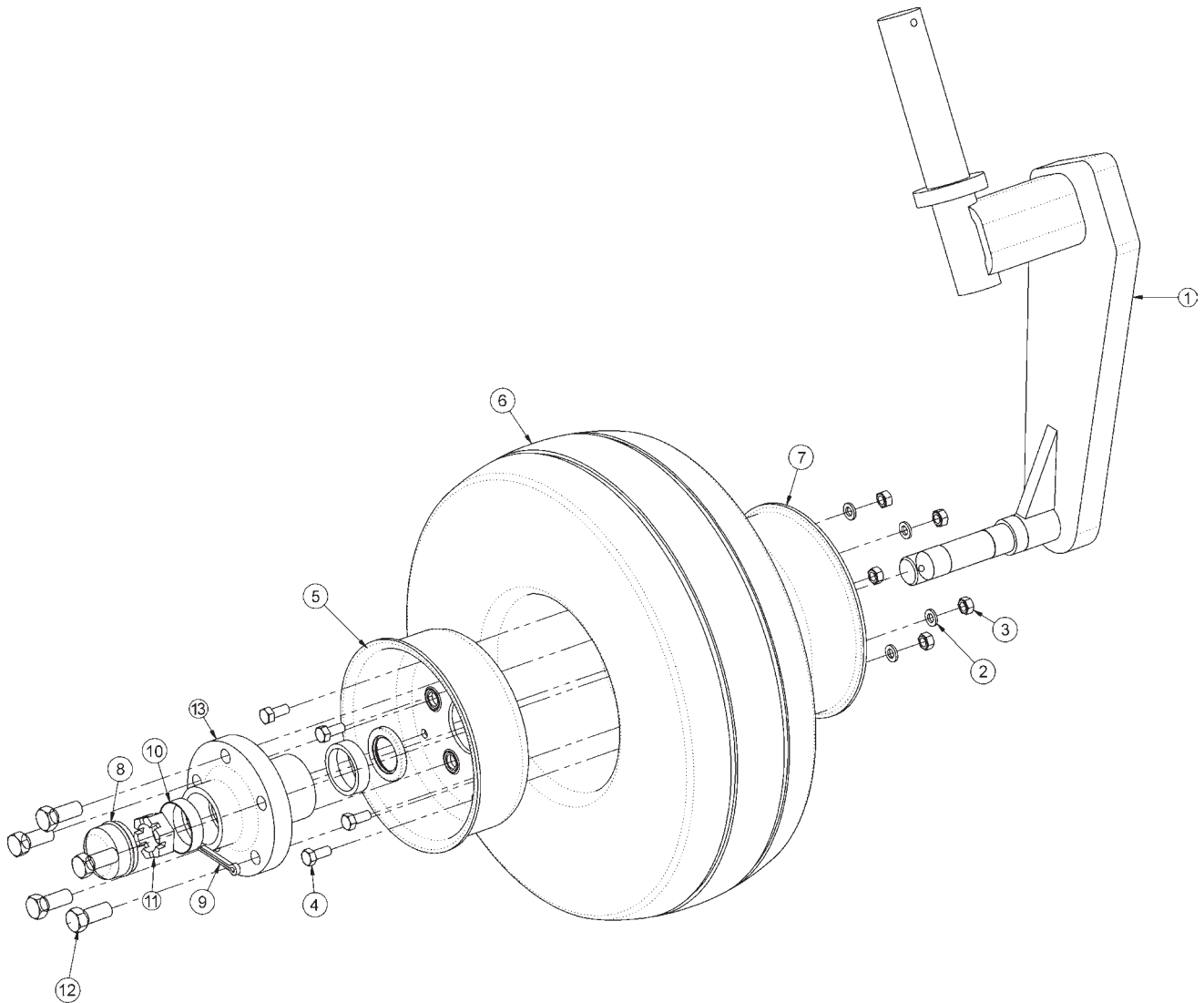

| ITEM | PART NO. | QTY. | DESCRIPTION |
|------|----------|------|--------------------------------|
| 1 | 21459 | 1 | SPINDLE, CASTER WHEEL AXLE |
| 2 | 21987 | 5 | LOCKWASHER, 5/16" |
| 3 | 21575 | 5 | HEX NUT, 5/16" |
| 4 | 8548 | 5 | CAPSCREW, 5/16" x 3/4", NC |
| 5 | 22697-1 | 1 | RIM, OUTER/RR RTRY CASTER ASSY |
| 6 | 21416 | 1 | TIRE, SOLID, RR-RTRY |
| 7 | 22696-1 | 1 | RIM, REAR ROTARY CASTER |
| 8 | 22070 | 1 | DUST CAP |
| 9 | 22533 | 1 | COTTER PIN, 3/16" X 2" |
| 10 | 6T0836 | 2 | CUP, CASTER WHEEL |
| 11 | 22073 | 1 | HEX NUT, 1NF (SLOTTED JAM NUT) |
| 12 | 22071 | 5 | HUB STUD |
| 13 | 22066-1 | 1 | HUB CASTER (REAR ROTARY) |

BRAKE VALVE ASSEMBLY W/ METRI PAK

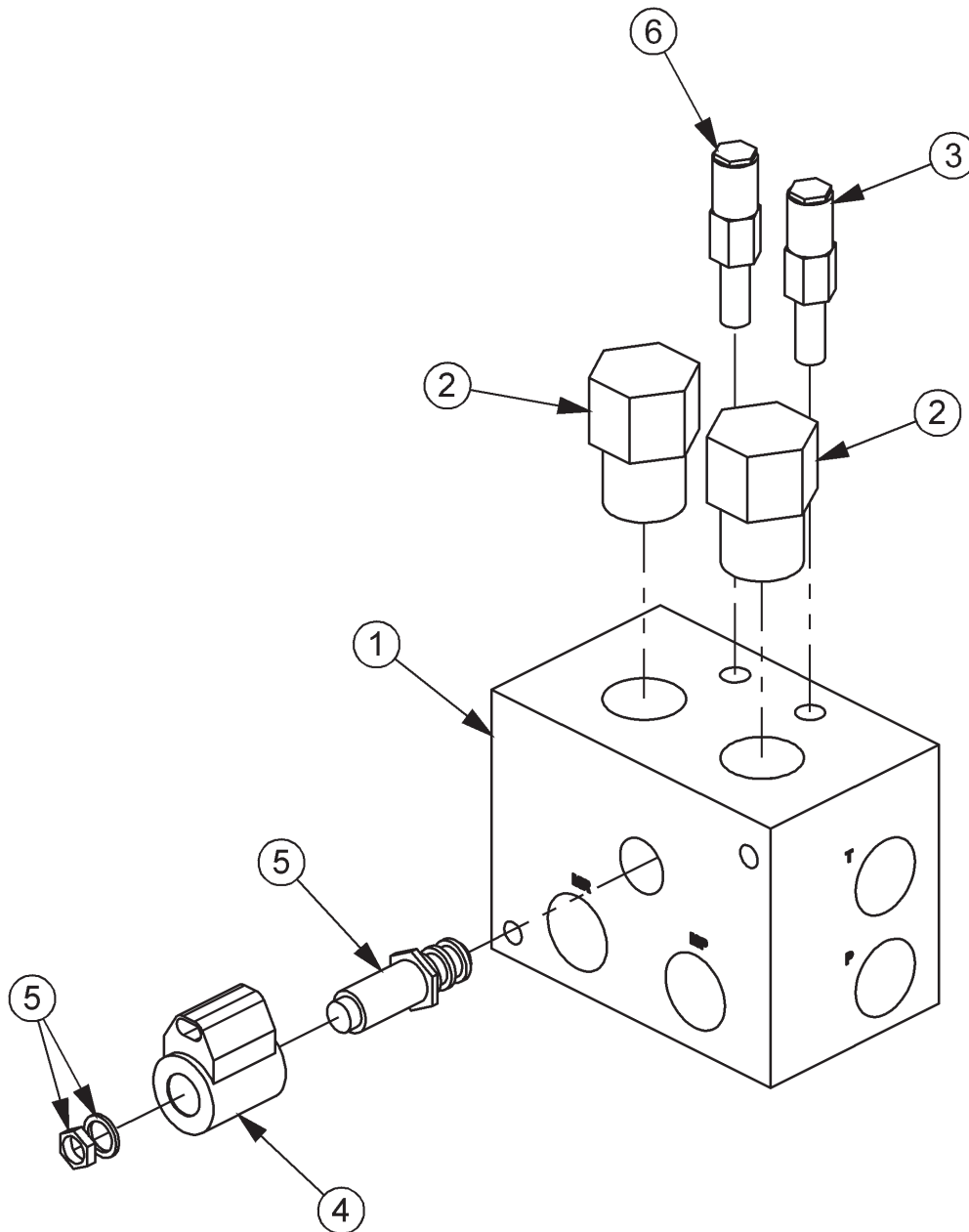

| ITEM | PART NO. | QTY. | DESCRIPTION |
|------|----------|------|--|
| 1 | 34092 | 1 | BRAKE VALVE, BLANK |
| 2 | 34094 | 2 | LOGIC ELEMENT |
| 3 | 34095 | 1 | RELIEF VALVE, 3500 PSI |
| 4 | 06510095 | 1 | METRI PAK COIL |
| 5 | 34093 | 1 | CARTRIDGE, 2 POSITION, 3 WAY (WITH NUT & WASHER) |
| 6 | 34091 | 1 | RELIEF VALVE, 2600 PSI |

SWITCHBOX SERVICE PARTS

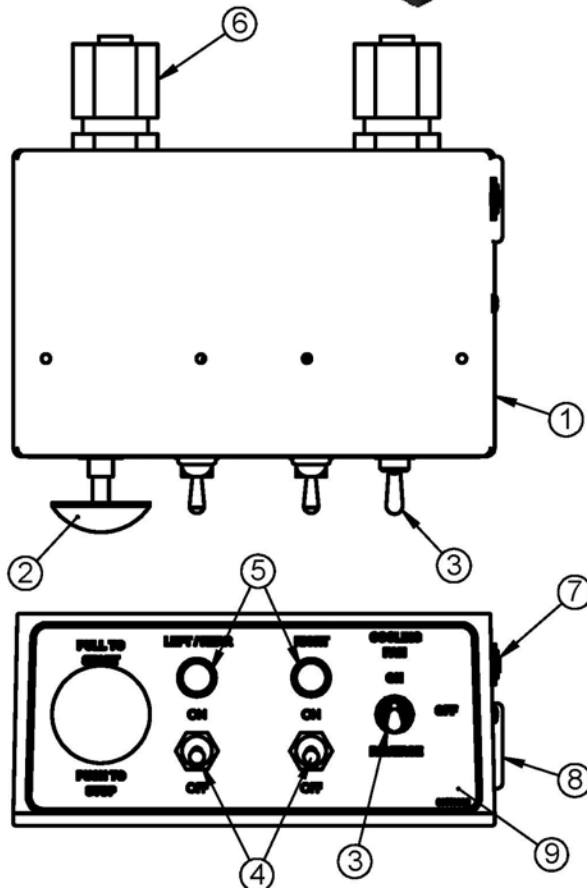

| ITEM | P/N | QTY. | DESCRIPTION |
|------|----------|------|--------------------------------|
| 1 | 06514011 | 1 | SWBX,ALUM,BLK,06510097 |
| 2 | 35226 | 1 | SWITCH,MOWER,COLEHERSEE |
| 3 | 06510028 | 1 | SWITCH,FORWARD/BRAKE/REV |
| 4 | 33811 | 2 | SWITCH,MASTER/DECK FLOAT |
| 5 | 6T3923 | 2 | INDICTATOR LIGHT,ON,RED |
| 6 | 34540 | 2 | STRAIN RELIEF,3/4,BLACK,NYLON |
| 7 | 06514006 | 1 | BREAKER,15A,SWBX |
| 8 | 06514015 | 1 | ALARM,SWBX,REVERSER |
| 9 | 06550002 | 1 | DECAL,SWTCHBX,TWINT/3F,REV FAN |
| 10 | 35227 | 1 | RELAY,DP,DT,12V,LY2F,35226 |

SWITCHBOX SCHEMATIC

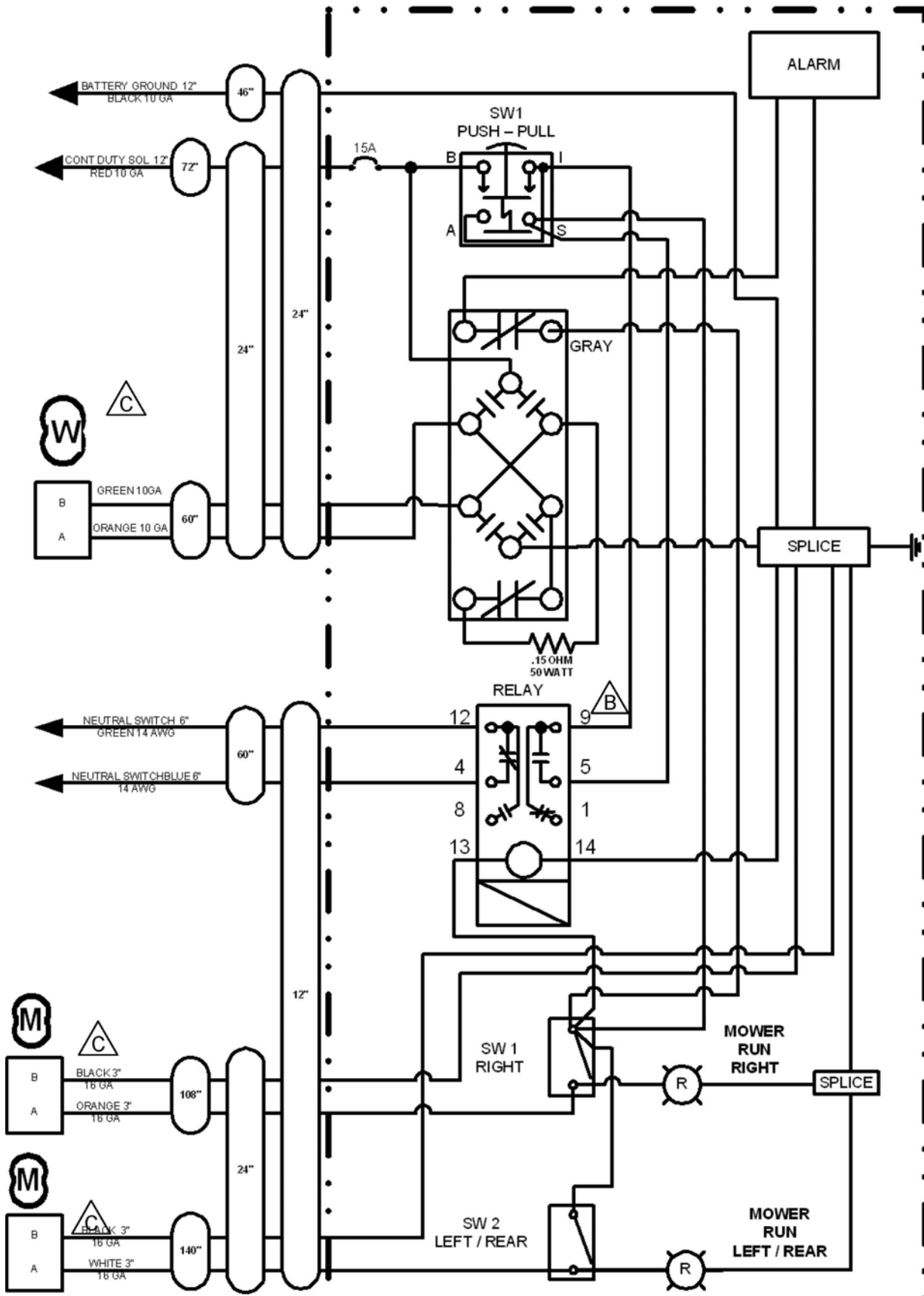

**WARRANTY
SECTION**

WARRANTY INFORMATION

Tiger Corporation, 3301 N. Louise, Sioux Falls, South Dakota, warrants to the original Retail Customer, the new Tiger equipment is free of defects in material and workmanship. Any part of equipment that in Tiger's judgement, show evidence of such defects will be repaired or replaced without charge, provided that the failure of part(s) shall have occurred within twelve (12) months from the date of delivery of said equipment to the Retail Customer. Expendable components such as knives, oil, chain sprockets, skid shoes, knife mounting disks and the like are excluded but not limited to this warranty.

The Retail Customer must pay the transportation cost to and from the Tiger Dealer's service shop for warranty service. Warranty service will be performed by the Tiger Dealer from whom the equipment was purchased, during service shop regularly scheduled days and hours of operation.

All Tiger obligation under this warranty shall be terminated if the equipment is modified or altered in ways not approved in writing by Tiger, if repair parts other than genuine Tiger repair parts have been used, or if the equipment has been subject to misuse, neglect, accident, improper maintenance or improper operation.

Tiger Corporation reserves the right to make improvements in design or changes in specification at any time without incurring any obligation to owners of equipment previously sold.

No agent or person has authority to alter, add to or waive the above warranties which are agreed to be in the only warranties, representations or promises, expressed or implied, as to the quality or performance of the products covered and which do not include any implied warranty of merchantability or fitness. In no event will Tiger be liable for incidental or consequential damages or injuries, including, but not limited to, loss of profits, rental or substitute equipment or other commercial loss.

**THERE ARE NO WARRANTIES WHICH EXTEND
BEYOND THOSE EXPRESSED HEREIN.**

It is the Purchasers obligation to sign the warranty registration form **AFTER** he / she has Read and Understands the Operation and Safety Instructions stated within this manual.

ONE LAST WORD

This manual cannot possibly cover all of the potentially hazardous situations you will encounter. By being familiar with the safety rules, operating and maintenance instructions in this manual you can help prevent accidents. The objective of this manual is to help make you a better operator. Remember, **SAFETY IS YOU!**



1012

Your safety and the safety of those around you depends on **YOU**. Common sense should play a large role in the operation of this machine.

Since we at Tiger Corporation are constantly striving to improve our products, we reserve the right to change specifications or design at any time.

TO THE OWNER / OPERATOR / DEALER



To keep your implement running efficiently and safely, read your manual thoroughly and follow these directions and the Safety Messages in this manual and on the machine. The table of contents clearly identifies each section where you can easily find the information you need.

The Occupational Safety and Health Act (OSHA 1928.51 subpart C) makes the following minimum requirements for tractor operators.

OWNER REQUIREMENTS:

1. Provide a Roll-Over-Protective Structure that meets the requirements of this Standard; and
2. Provide Seatbelts that meet the requirements of this Standard and SAE J3C; and
3. Ensure that each employee uses such Seatbelt while the tractor is moving; and
4. Ensure that each employee tightens the Seatbelt sufficiently to confine the employee to the protected area provided by the ROPS.

OPERATOR REQUIREMENTS:

1. Securely fasten seatbelt if the tractor has a ROPS.
2. Where possible, avoid operating the tractor near steep ditches, embankments, and holes.
3. Reduce speed when turning, crossing slopes, and on rough, slick, or muddy surfaces.
4. Stay off slopes too steep for safe operation.
5. Watch where you are going – especially at row ends, on roads, and around trees.
6. Do Not permit others to ride.
7. Operate the tractor smoothly – no jerky turns, starts, or stops.
8. Hitch only to the draw-bar and hitch points recommended by the tractor manufacturer.
9. When the tractor is stopped, set brakes securely and use park lock, if available



Printed in USA
© Tiger Corporation