



Triple Threat Triple Flail Mower



INNOVATIONS ON THE MOVE

The power to cut through large swaths of grass...the performance necessary to tackle your toughest mowing areas and built with the strength to last. Get it all with Tiger's Triple Threat - triple flail mower.

With 50 years of commitment, giving our customers the best built mowing products on the market, Tiger has designed a hydraulic driven triple flail pull mower that is completely self-contained. Each mower can operate independently or a combination of any of the 3 mowing heads simultaneously.

Great for wide area and airport mowing, the versatility of this innovative machine allows you to tackle your toughest mowing projects quickly and then simply disconnect the mower and use your tractor for other demanding jobs.



DURABILITY INNOVATION

COMMITMENT

Tiger Features

Productivity. Performance. Power.

Tiger's Triple Threat -Triple Flail Mower is built to give you more power with ease of operation.

14 function keypad in tractor gives accurate control of complete mowing system with the simple push of a button.

Designed to attach to any 1000 PTO tractor with easy battery hookup for power.

Extreme duty flail mowers can handle grass and brush up to 1" in diameter and boasts a cut path of over 18'8".



LEGAL WIDTH AND ROAD READY



QUICK DISCONNECT DRAWBAR HITCH

CONTROL KEYPAD



COMPUTERIZED COOLING FAN



Developed to handle today's mowing challenges with quick disconnects for easy detachment and built with your transportation needs in mind. When mowers are up and locked, unit is legal width, ready to travel safely from job site to job site . Tiger Extreme Duty Flails are designed and built to meet and exceed ANSI and SAE standards.

Minimum Tractor Requirements

- Horse Power** 85 HP PTO Minimum
- PTO required** 1000 PTO
- Drawbar weight** 1675 lbs.

Features

- Hydraulic System** 50 gallon tank with integrated sight glass
- Quad Pump System** 3 - 27 gpm pumps, one for each flail
1 - 12 gpm pump for all 5 cylinder functions
- Safety Stop** 7 Second Shut Down
- Cutter Heads** 75" side flails, 90" rear flail
- Cut Diameter** 1" grass or brush
- Cutting Height** 1/2" to 6"
- Cutter Knife** Forged Heavy Duty
- Cutter Shaft** Extreme Duty flail type, 6" diameter
- Tilt Switch** Adjustable shut off from 0° to 90°, side heads
- Weight** 7450 lbs.

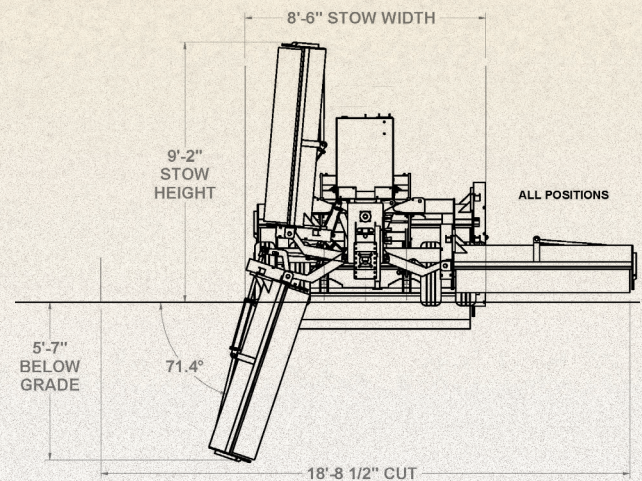

Dealer Info:

Tiger Mowers LLC
3301 North Louise Ave.
Sioux Falls, SD, USA 57107
800.843.6849
www.tigermowers.com



An Alamo Group® Company
Specifications are subject to change. Optional equipment may be shown.

Meets All Applicable ANSI / SAE Test Standards.
© 2022 Tiger Mowers LLC. All Rights Reserved. Printed in the USA.

